

BUILD OUR TELEVISION SOUND SET

SEE
PAGE 83

Practical and Amateur Wireless

3^D
EVERY
WEDNESDAY

Edited by F.J. CAMM

a GEORGE
NEWNES
Publication

Vol. 9. No. 211.
October 3rd, 1936.

AND PRACTICAL TELEVISION

Adjusting & Operating



F. J. Camm's
"LIMIT"
All-Wave
4

A Book for Every Up-to-date Wireless Enthusiast!

EVERYMAN'S WIRELESS BOOK

By F. J. CAMM (Editor "Practical and Amateur Wireless," etc.)

A Radio Consultant for the Listener, Expert and Amateur Constructor, explaining the Operation, Upkeep and Overhaul of all Types of Wireless Receivers, with Special Chapters on the principles of Radio Telephony, Installation, and Systematic Fault-finding.

From all Booksellers, only 3/6 net, or 3/9 post free from

With
200
Illustrations

GEORGE NEWNES, LIMITED, 8-11, Southampton Street, Strand, LONDON, W.C.2.



COSSOR 5-VALVE

PENTAGRID
FREQUENCY
CHANGER

DOUBLE DIODE
TRIODE 2ND
DETECTOR
AND AMPLIFIER

AUTOMATIC
VOLUME
CONTROL

SUPERHETS *for* A.C. & D.C./A.C. Mains Operation

THESE powerful Superhets incorporate all those advances which mean certain and satisfactory reception of a large number of home and continental programmes. Stations on adjacent wavelengths can be separated with ease. Effects of 'fading' are obviated by the use of Full Automatic Volume Control. Distortionless rectification is assured by a Double Diode Triode, whilst the combination of a High Slope Power Pentode and a carefully matched Energised Moving Coil Speaker ensure adequate volume with fine reproduction.

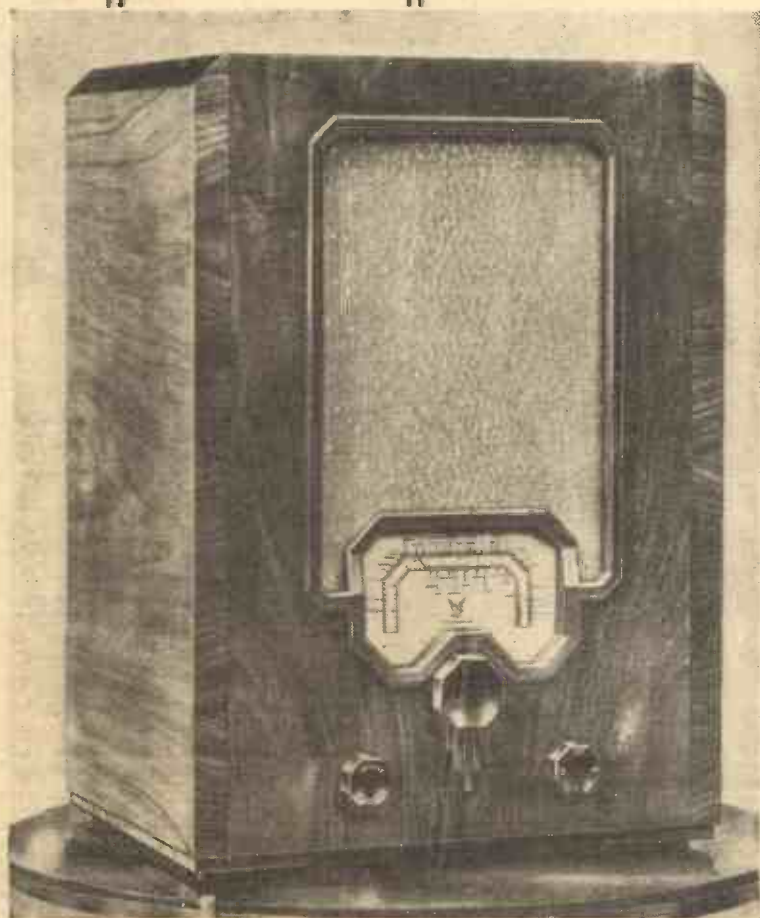

5-VALVE A.C. MAINS MODEL 375

Five valves (including Rectifier). Single-knob Tuning. Illuminated Wavelengths Scale with station names. Combined Radio and Gramophone Volume Control. Tone Adjustment. 8" Energised Moving Coil Speaker. Magnificent Walnut Cabinet. 19 $\frac{3}{4}$ " by 14 $\frac{1}{2}$ " by 11 $\frac{1}{2}$ ". For A.C. Mains only, 200-250 volts (adjustable), 40-100 cycles.

PRICE **9 $\frac{1}{2}$ GNS**

Hire Purchase Terms:

12 months: 17/6 deposit and 12 payments of 17/3
18 months: 17/6 deposit and 18 payments of 12/6

5-VALVE D.C./A.C. MAINS MODEL 375U

Specification generally similar to Model 375, but for operation on D.C. 200-250 volts (adjustable) and A.C. 200-250 volts (adjustable), 50-100 cycles.

PRICE **10 GNS**

Hire Purchase Terms:

12 months: 18/6 deposit and 12 payments of 18/-
18 months: 18/6 deposit and 18 payments of 12/9

Prices do not apply in I.F.S.

A. C. COSSOR Ltd., Highbury Grove, London, N. 5.

MODERN TUNING DEVELOPMENTS—See page 69



Practical

and Amateur

Wireless

Edited by F. J. C. AMM

Technical Staff:
W. J. Delaney, H. J. Barton Chapple, Wh.Sch.,
B.Sc., A.M.I.E.E., Frank Preston.



VOL. IX. No. 211. Octobr 3rd, 1936.

ROUND *the* WORLD of WIRELESS

Secret B.B.C. Tests

SOME special tests in secret have been carried out at Burghead by the B.B.C. on the Scottish Regional wavelength. The two transmissions have been synchronised and tuning-fork control has, in conjunction with special apparatus designed by the B.B.C., enabled the two transmitters to keep perfectly in step and thus effect a great economy in gear. If the idea is developed a number of stations will be erected round the country and thus provide everybody with a good input signal, and better quality should result from this scheme.

Bristol Looks Up

THE Postmaster-Surveyor for the Bristol district states that there is one set for every five listeners in the Bristol area and this is claimed as a record. The population of the area is 475,000, and the number of licences in force at the end of August was 100,062. In the first ten days of September there were no fewer than 607 applications for new licences at the Bristol office. Is this due to the influence of the Radio Exhibitions, or the forthcoming winter evenings?

Television in Hotels

A WELL-KNOWN hotel at Hendon, in the north-west district of London, claims to be the first hotel in the world to instal a television receiver for the use of its patrons. The receiver is a Cossor and was fitted up during the exhibition at Radiolympia, and may be viewed by anyone visiting the brasserie. The claim has now been attacked by a north country firm, who claim that they installed a 30-line receiver many moons ago. Are there any further claims?

Radio Surgery

THE use of high-frequency radiations in the treatment of diseased tissue and other applications of H.F. radiations in surgery opens up many interesting problems. Firstly, interference with radio apparatus over a very large area; secondly, the limits to which the apparatus may eventually be put; and thirdly, the unforeseen effects of certain radiations not at present recognised in powerful short-wave transmitters. These problems are being investigated in the U.S.A.

Sets of Old

RECENTLY, at the well-known Cale-donian Market at Islington, a stallholder was endeavouring to dispose of an early Marconi V2 receiver. This was complete with the original valves, and was working on the stall with a short length of flex as an aerial. We wonder how many hours' service this set had seen.

Imperial Airways and D.F.

THE wireless installations now being fitted to the new Empire flying-boats are claimed to be the most modern and efficient ever constructed for use in commercial aircraft. The D.F. apparatus is now embodied in the main set and is not a separate piece of equipment. The operator may tune in any ground station within operating range and plot out the air-liner's position at any time during a flight.

Trial Television Programmes

ACCORDING to a recent B.B.C. announcement, a period of trial television programmes to be broadcast from the Alexandra Palace is expected to commence early this month, and to last for about four weeks. These transmissions will be primarily for test purposes, for the benefit of the trade and the B.B.C. Details of the programmes will not be regularly announced, but, so far as possible, the public will be kept informed of the hours at which transmissions will take place. The inauguration of the regular television service will follow at the end of this period, probably during the first week in November.

Televised Race Meeting

IN the present series of television experimental transmissions an ambitious attempt is to be made to relay a race meeting at the Alexandra Park grounds. This will be on October 10th, and the transmitter will be connected to the course through about 1,000 feet of cable. This should be a highly successful broadcast.

Air Ministry Reports

IF any readers are interested in the Air Ministry reports they may hear them each day on 1,181 metres at the following times: 7.45, 9.30, 11.30, 12.30, 1.30, 3.30, 5.30 and 6.30.

"City and Seaside"

VICTOR SMYTHE, the North's Outside Broadcast chief, has arranged another big composite programme representative of both "City and Seaside." The broadcast will be given on October 9th, and the programme will include Frank A. Terry's concert party, "The Marina Pleasure Parade," from the Empire Theatre, York, and Tom Vernon's Royal Follies concert party from the Central Pier, Blackpool.

ON OTHER PAGES

	Page
The Advantages of Radio Extensions	67
Tuning Developments	69
Components for Constructors	70
Thermion	71
Cossor's Latest Receiver	74
Readers' Wrinkles	75
Radio for Cyclists	76
Practical Television	77
Operating the "Limit" All-Wave 4	78
A.B.C. of the Modern Receiver	80
Operating the Septimetre	83
Short-Wave Section	85
Impressions on the Wax	87

Ireland's Problem

THE Irish Radio Exhibition which has recently closed presented a small problem. The Show was visited by 2,000 fewer people, but over a 1,000 more paid for admission as compared with last year. This discrepancy is stated to be due to the fact that this year there were fewer complimentary tickets.

Sheffield Radio Classes

AT the Sheffield University classes in radio technology are again being held on Wednesday afternoons during the winter. The third year's course will commence shortly.

THE PICK of the PROGRAMMES

"Cavalcade"

NOEL COWARD'S famous Drury Lane production, "Cavalcade," will be heard again in the National programme on October 9th. Felix Felton and Val Gielgud, the joint producers, are optimistic of obtaining the majority of the same brilliant cast which proved such a great success previously, namely, Mary O'Farrell, Martin Lewis, Joyce Barbour, Eliot Makeham, and

MAKE THESE DATES
WITH YOUR RADIO

will be the Ninth (D minor Choral), in which the B.B.C. Choral Society will take part, and the soloists will be Elsie Suddaby, Margaret Balfour, Parry Jones, and Harold Williams.

A DE-LUXE RADIOGRAM



Miss Judy Kelly, the B.I.P. star, with her McMichael 365 radiogramophone, as she appears in the new Welwyn picture "Double Error," to be released shortly.

Cathleen Nesbitt. Great interest was taken by producers' outside broadcasting in the radio edition of this play.

"Sea Power"

THIS is to be the title of the third section in the series of talks called "Down to the Sea in Ships." These talks will deal with the influence of sea power on Britain and its value to an island realm. The series is not intended to deal with the technicalities of the balance of power between sea and air necessary to an island state. The talks will deal chiefly with food and fuel supplies, sea transport, and the conveyance of raw materials and manufactured goods.

"The Palaver is Finished"

THE Saturday evening thriller which was included in "Saturday Magazine" last season has, as already announced, been removed from the "In Town Tonight" programme. This serial thriller proved extremely interesting to listeners, and owing to its popular appeal will this time figure as a section on its own. "The Palaver is Finished" will be broadcast in the National programme on October 12th.

Promenade Concerts

ON October 1st, Mendelssohn's Scottish Symphony will be broadcast (Regional), and on the Beethoven night, October 2nd (National), the symphony

On October 3 (the final concert of the season), the first performance in England of an arrangement for full orchestra of Bach's Chaconne by Alfredo Casella will be broadcast. The programme also includes three numbers from the "Planets," by Holst, and Elgar's "Pomp and Circumstance," March No. 1.

A Russian Farce

THE series of plays from Midland Repertory Companies is now organised on a basis of one long play and one short play from each company in a year. The longer play, to be given by the Oxford Repertory Company on October 5th, from the Midland Regional, is Valentine Kataev's farce of post-Revolutionary Moscow "Squaring the Circle." It is a studio production by Owen Reed.

Midland Part-songs

THE B.B.C. Midland Singers, conducted by Edgar Morgan, are to give each month a programme of part-songs, by contemporary Midland composers. The broadcast on October 7th will be the first of the series.

Celebrities of the West

THE third programme in the series entitled "Celebrities of the West" will be broadcast on October 5th, when listeners will hear Marie Hall (violin) and Mary Ramsay (pianoforte) playing Purcell's

Sonata in C minor and Beethoven's Sonata in F major, Op. 24.

Sonata Recital

ON October 6th, in the Western programme, Enid Payne (pianoforte) will broadcast a sonata recital, when she will play Sonata in E minor, Op. 35, by Emil Sjögren, and Sonatina No. 2 in C, by Charles Kocchlin.

Concert from Penzance

HELEN SANDOW (contralto) will be the vocalist in a concert by the Newlyn Male Voice Choir, conducted by J. Morgan Hosking, to be broadcast from Penzance on October 9th.

Rhythm Soloists

THE second programme in the second series of gramophone recitals entitled "Rhythm Soloists" will be broadcast from the Western Regional on October 10th, when listeners will hear violin and trombone soloists.

Organ Recital from Bournemouth

KENNETH BYGOTT, who first broadcast in July from the organ of the Regent Cinema, Bournemouth, in the programme "You Pays Your Money," will be heard again at the organ of the Regent Cinema on October 10th.

Hull Fair

PHILIP ALLINGHAM, the well-known "cheapjack," who has broadcast previously in the national programme, is to tell Northern listeners on October 10th about Hull Fair, and to introduce them to some of the well-known showmen and other interesting people attending the fair.

Scottish National Radio Exhibition

THE Seventh Annual Scottish National Radio Exhibition, the opening ceremony of which will be broadcast, opens in the Waverley Market, Edinburgh, on October 7th. During the course of the exhibition a number of interesting programmes will be broadcast from the platform in the Waverley Market.

SOLVE THIS!

PROBLEM No. 211.

The reaction H.F. choke in Herbert's short-wave receiver broke down and a replacement was not available, but he had a varied selection of resistances on hand. What resistance value should he use in place of the choke? Three books will be awarded for the first three correct solutions opened. Address your letters to the Editor, PRACTICAL AND AMATEUR WIRELESS, Geo. Newnes, Ltd., 8-11, Southampton St., Strand, London, W.C.2. Envelopes must be marked Problem No. 211 in the bottom left-hand corner, and must be posted to reach this office not later than the first post Monday, October 5th, 1936.

Solution to Problem No. 210.

The bias resistance should be connected between the HT— and LT— leads with the GB— lead joined to HT—. The required value of resistance in ohms can be calculated by dividing the specified bias voltage in volts by the total current consumption in amperes, i.e., by $12\frac{1}{2}/1,000$ in this case. The following three readers successfully solved Problem No. 209, and books are accordingly being forwarded to them: W. J. Cunliffe, 32, Whittlefield St., Burnley; R. Tod, 283, Kilmarnock Rd., Newlands, Glasgow, S.3; W. G. Stripp, 8, Pancras Rd., London, N.W.1.

The Advantages of Radio Extensions

Suggested Ways for Extending the Pleasure of Listening to Any Part of the House are Discussed in This Article

THERE are many alternative arrangements whereby radio can be extended to every room of the house, and not only do these fully cater for the needs of listeners, but also furnish opportunities for the home constructor to exercise his ingenuity. These schemes can be divided into two distinct types, which may be termed the single receiver and extension

By H. J. BARTON CHAPPLE, B.Sc.,
A.M.I.E.E.

from the line, but spaced wires should be used to avoid capacity effects, and a speaker of high impedance or one fitted with a transformer must be used. A single-wire extension with earth return may be employed with this system, as shown in Fig. 4. It is an advantage to provide a switch whereby the speaker in the set can be silenced if desired without cutting off the extension circuit, and the position of this is also indicated in Fig. 4.

a set which can be tuned to only two or three different stations by means of pre-set tuned circuits switched by means of relays. In view, therefore, of the limited field of application of remote tuning, this section of the subject will not be discussed here; but remote control of the on/off switch is quite a practicable proposition.

One arrangement is to use a "latching" relay in which a switch, which acts as the main on-off switch for the set, is opened and closed by means of two-way push buttons. Suitable relays are on the market and consist of two electro-magnets, one of which opens the relay contacts when energised, the armature being latched in the "off" position by the armature of the second magnet. When, however, the second magnet is energised, its armature is attracted and releases the first armature, thus causing it to close the main circuit. Three control wires are required, as shown in Fig. 5, but if choke output is used the common lead of the control circuit may also be used as one of the extension speaker leads, so that only four wires in all are necessary, as shown in Fig. 6.

A very simple but most efficient complete remote control loudspeaker extension outfit is the Whiteley "Long Arm" unit.

(Continued overleaf)

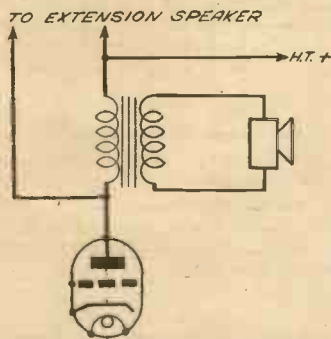

Fig. 1.—Taking the extension speaker lines from the primary of the speaker transformer

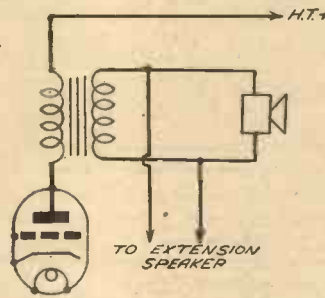

Fig. 2.—An alternative arrangement to that shown in Fig. 1

circuit type, and the communal aerial system using either a transportable set or several receivers.

Loudspeaker Extension Systems

Because they call for only one centrally located set and simple low frequency wiring, extension systems are used to a greater extent than communal aerial systems. Most commercial sets are now fitted with extension sockets which can be connected to lines running to speakers in other rooms, and it is quite an easy matter to fit such connections to existing sets. Figs. 1, 2 and 3 show a number of typical arrangements, the choice of which depends upon the design of the output circuit of the set. In Fig. 1 is shown one scheme whereby the extension circuit is taken from the primary of the speaker transformer. This calls for a well insulated extension line as the full H.T. voltage is applied to it, and the two wires should be well spaced to avoid capacity losses affecting the high notes. Moreover, the extension speaker or speakers must be provided with suitable matching transformers. The extension circuit shown in Fig. 2 is taken across the secondary of the set's output transformer, and the insulation of the extension wiring need not be of such a high grade, while the extension speaker should be of the low impedance type. Capacity losses are negligible and twin cable can therefore be used, but it should be of substantial section to avoid ohmic losses.

Undoubtedly a better plan is that indicated at Fig. 3, where the primary winding of the output transformer is used as a low-frequency choke, and the extension circuit is taken through a 2 or 4 mfd. condenser. The H.T. voltage is isolated

house, and in most cases represent the normal installation, they have the disadvantage that if, when listening in

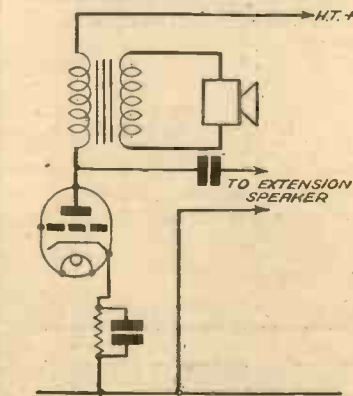

Fig. 3.—Using the speaker transformer primary as a choke

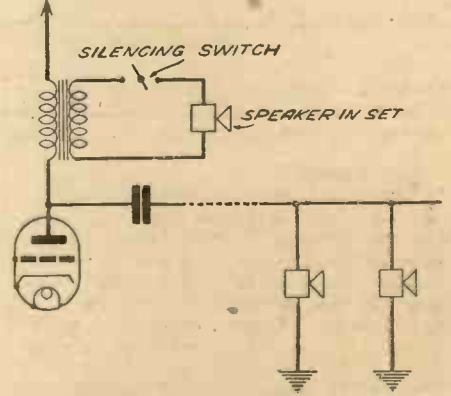

Fig. 4.—Using an earth return, showing the position of the silencing switch

another room, it is desired to hear another programme or to switch off entirely, a visit must be paid to the room in which the set is situated in order to retune or to operate the switch. Remote control of tuning has been achieved in one or two commercial sets, but is only practicable for the constructor on a small scale, that is to say, by employing

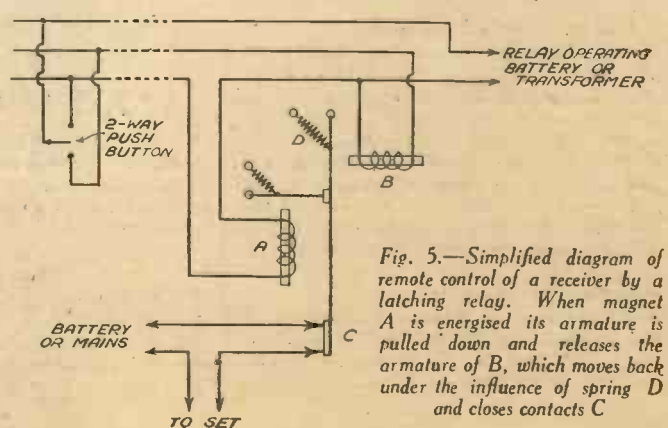

Fig. 5.—Simplified diagram of remote control of a receiver by a latching relay. When magnet A is energised its armature is pulled down and releases the armature of B, which moves back under the influence of spring D and closes contacts C

THE ADVANTAGES OF RADIO EXTENSIONS

(Continued from previous page)

A push button and volume control is provided on each W.B. extension speaker, and the unit may only be operated from a distant point with the volume control in its minimum position. The unit is fitted in a position conveniently close to the set, and the set leads (battery or mains) attached to the plug provided by the unit. The extension speaker leads from the set are attached to terminals also provided on the unit. Three terminals are provided for output from the unit to the extension speaker or speakers, to which is attached a three-core cable, one lead of which feeds one side of speaker input, one which is a common lead to the speaker, and also from the extension speaker push button to the battery operating the relay. The third lead provides the other connection from the push button to the battery. The two leads to the battery are specified as 23/36's to maintain a low resistance line and thus avoid excessive voltage drop on the relay circuit. The relay is operated by means of a 4.5 volt solenoidal magnet. This magnet pulls down a hinged top yoke to which is attached a silver-faced contact. Another silver-faced contact mounted on a pillar completes the supply circuit when the hinged top yoke is in the lower position where it is held by means of an ingenious locating cam. When the relay is operated again the hinged yoke is released and the circuit broken.

A circuit diagram showing the complete scheme for this device is given in Fig. 7, and it has the distinct advantage that current is only drawn from the battery during the short time that the push button is operated, the cam and spring ensuring correct make or break as required.

Ingenuous constructors may like to experiment with relays of their own

There are also mains transportables with frame aerials, and many other mains sets have mains aerial connections which permit of transportability without the necessity of connection to an external aerial. While allowing local control of tuning, volume and so forth, impossible with simple speaker extensions, the frame-aerial or mains-aerial system usually imposes some limits on the range of the receiver, and less than the normal number of stations is receivable, while mains interference may be increased.

In the majority of instances, however, it is better for the subsidiary receiver or

the loft may be provided for use when a set is wanted in the bedroom.

Where a single aerial is required to serve all parts of the house, proper arrangements must be made, for if two sets are connected directly to one aerial, they usually upset tuning to a considerable extent unless they are tuned to stations greatly differing in wavelength. The usual solution is to fit a communal aerial, which is connected to earth via the primary of a specially designed radio-frequency step-down transformer, the secondary winding being connected to a pair of lead-covered leads

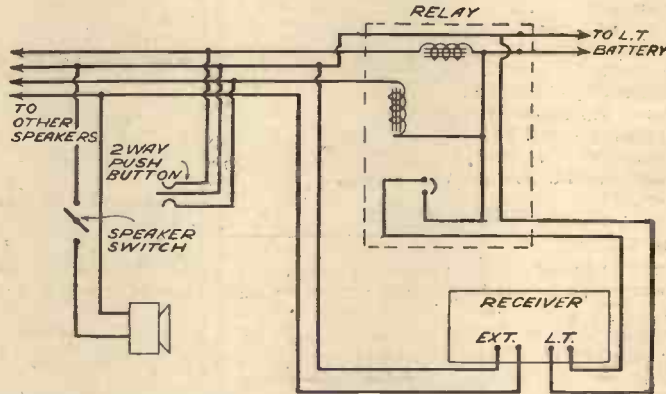

Fig. 6.—Connection for remote control of battery set using four wires only

receivers to be connected to a proper aerial and earth system, and a number of different schemes are possible. If the receivers under consideration are sufficiently sensitive, and local conditions are favourable, the complications associated with running two or more receivers from one aerial can be avoided by rigging up separate picture rail or loft aerials. For example, the main receiver may be operated from the outdoor aerial, and the set in the dining room from a picture rail aerial, while another aerial in

which run to the various rooms. At each point where it may be desired to connect a receiver is placed a socket connected to the aerial extension circuit, and each receiver is fitted with a step-up aerial transformer to "match" the input to the low impedance aerial line. In addition to conferring the benefit of being able to plug a receiver into a socket in any room, this scheme has the further advantage that, if the aerial proper is erected outdoors and outside the field of electrical interferences,

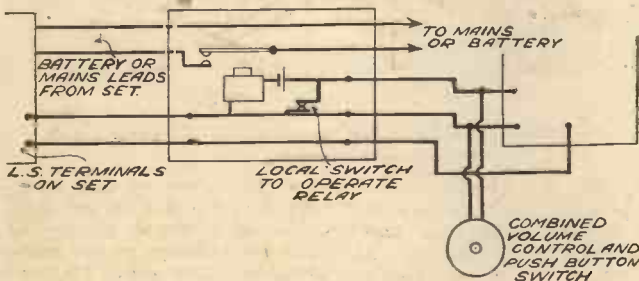

Fig. 7.—Details of the W.B. remote control extension speaker scheme

design, and in this connection the mercury-tube switch offers great possibilities. Sealed tubes containing two fused-in contacts and a small quantity of mercury, which connects the two contacts when the tube is tilted, may be bought very cheaply, and Fig. 8 illustrates a simple suggestion for a suitable mechanism.

The Communal Aerial System

Instead of employing one receiver in a permanent position with speakers in different rooms, the receiver may be moved from room to room, or there may be a different set in each room, or a family set in the lounge and a small set which can be taken to any other room.

The case of the portable battery set with its self-contained frame needs no explanation, and a set of this type as an adjunct to the fixed receiver may solve the extension problem in many instances.

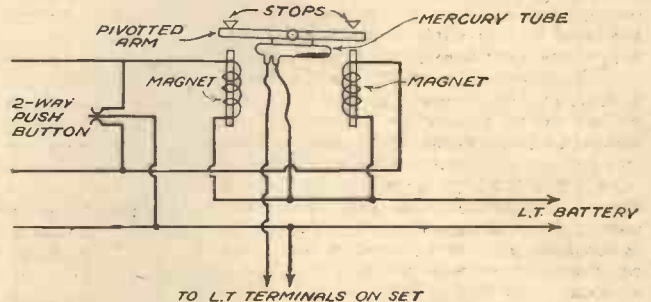

Fig. 8.—Basic scheme for mercury switch relay for remote control

THE WIRELESS CONSTRUCTOR'S ENCYCLOPAEDIA

By **F. J. CAMM** 4th Edition **5/-** net.

(Editor of "Practical and Amateur Wireless")

Wireless Construction, Terms, and Definitions explained and illustrated in concise, clear language.

From all Booksellers, or by post 5/6 from George Newnes, Ltd., 8-11, Southampton Street, Strand, London, W.C.2.

the lead-covered transmission line will not pick up any interference on the way to the receivers, and man-made static of the radiated type will be avoided. Within reason, the transmission line may be of any length—certainly up to several hundred feet, and any number of sets up to, say, ten may be connected to one system, each, of course, through its own transformer.

Although the communal aerial system is more expensive to install, it gives individual local control of listening—a very important matter in the case of separate and distinct flats when different families have different ideas as to what they wish to hear. The home constructor may also welcome this arrangement, as it affords him opportunities for making up a multiplicity of receivers. Most amateurs have a number of old or partly dismantled sets on hand, and these may be modernised as suitable instruments for installing in different rooms.

Tuning Developments

THE number and power of broadcast transmissions are increasing year by year, yet listeners light-heartedly expect to maintain the same wide choice of programme. In fact, they look for more rather than less variety, and they want it at better and better quality and free from any trouble due to fading.

The consequence is that the modern receiver is becoming very complicated, containing double-diode pentodes, electron-coupled frequency-changers, and what not. In short, it has arrived at the stage where, like any other highly-organised product of engineering skill, it must be treated with respect and handled with circumspection if the best is to be got out of it.

Automatic Volume Control

The introduction of automatic volume control is primarily responsible for making tuning control a less simple affair than it used to be. A.V.C. means that the circuits automatically vary in sensitivity with each movement of the tuning dial. For instance, when the set is receiving the local B.B.C. station the valves are biased down so that the amplification is at a minimum. But when it is tuned in to a distant programme, the position is quite different, because the valves are then working at their hardest in order to boost up the feeble incoming signals to standard strength.

Follow now what happens as the dial is moved from one station to another. Directly the circuits lose touch with the programme they have been "holding," the valves automatically exert themselves to the utmost, seeking to bring in anything and everything within range. The result is an immediate uproar in the loudspeaker produced by a mixture of atmospherics and heterodyne howls from far-distant stations.

This disconcerting effect, which is known as inter-station "noise," can be prevented by the use of delayed or "quiet" A.V.C., which in effect automatically puts the loudspeaker out of action so long as there is no worthwhile station within range. But directly the listener picks up a signal worth listening to, the circuit to the loudspeaker is automatically restored and the set works as usual. The effect of Q.A.V.C. is very striking. As the control knob is slowly rotated, station after station comes in at uniform strength, each being separated by an interval of absolute silence.

A second difficulty introduced by A.V.C. arises from the fact that it is impossible to tell by the ear alone when one is accurately tuned in to a given station, particularly to a nearby station. Owing to the automatic regulation of the sensitivity of the valves, the incoming signal remains at constant strength even though the tuning-knob is moved over several degrees on the indicator scale. But although the strength remains constant, quality definitely falls off unless the indicator is set dead on the centre of resonance. For this reason "visual" tuning is now standard practice on all up-to-date sets fitted with A.V.C.

Switch-tuning

In theory the nearest approach to what may be called "foolproof" tuning is given by the method of switch or press-button control. Here a number of different tuning elements are thrown in and out of circuit by means of switches, each of which is

In this Article the Author Discusses Automatic Volume Control, and a Method of Switch Tuning.

By MORTON BARR

marked with the particular station it is desired to receive. This certainly leaves no room for careless or inaccurate handling, but, on the other hand, the choice of programme is necessarily limited by the fact that each station requires its own individual set of tuning components.

Fig. 1 illustrates an ingenious attempt which has recently been made to reproduce the effect of switch-tuning in a simple and inexpensive manner. For the sake of clearness only the essential components are shown.

The ordinary tuning knob K is provided with a special projecting switch-arm S, which moved over a series of contacts C as the knob is rotated. These contacts are arranged separate from the tuning dial but so that they correspond with the dial-position of a selected number of what we may call "worthwhile" stations. The idea is to limit reception to these stations only, and to cut out all background "noise" as the tuning control is moved from one of these stations to the next.

For this purpose a resistance R is arranged in the cathode circuit of the valve V, the contacts C being shunted across it in such a manner that whenever the switch-arm S rests on one of them, the resistance

But provided the switch-arm S rests on one of the contacts C, the resistance R is short-circuited and so can have no effect on any of the valves. This, of course, can only happen when the tuning-indicator is accurately set to a point on the scale which brings in one of the desired stations.

If the tuning is not dead accurate, the switch arm S just "misses" the corresponding contact C, and the blocking effect of the resistance R at once comes into action to keep the set dumb. In the same way the passage of any signals through to the loudspeaker is automatically stopped whilst the tuning control is being moved from

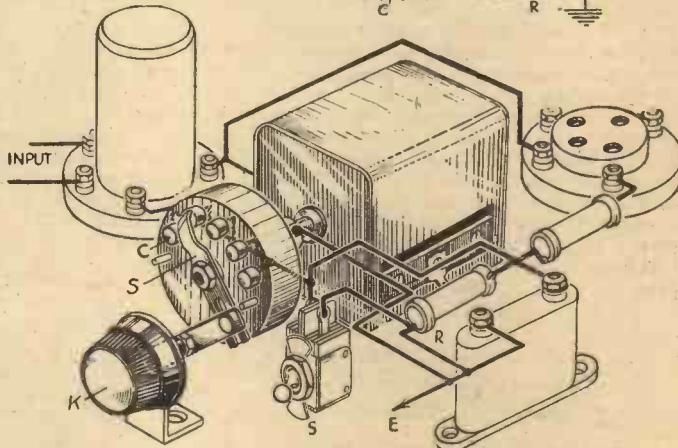
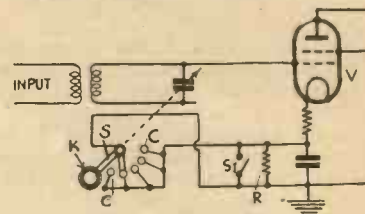

Fig. 1.—Pictorial diagram and theoretical circuit of a simple switch-tuning arrangement.

one station to the other, so that all unpleasant inter-station noises are cut out.

In short, the user of the set is compelled to tune it accurately before he can receive any programme; but he knows that once it comes in he will hear it undistorted. In addition, he also enjoys the advantage of changing over from one station to another on a "quiet" background. If he prefers to depend upon ordinary tuning control, he can do so by closing the switch S1 and so permanently short-circuiting the resistance R.

An Alternative Method

Fig. 2 shows another simple device for securing very much the same effect. Here the shaft S of the tuning-control carries a wheel W, which is so toothed or grooved that each depression—or at least most of them—corresponds exactly with the tuning position of a station that is worth listening to.

A lever L is pivoted at N and carries at one end a plunger P which rides over each tooth as the tuning knob is turned, but is forced down by a spring into each of the slots, as shown, so as to produce a step-by-step effect. The other end of the lever rests against a contact C as long as the plunger P is in its depressed position,

(Continued on page 74)

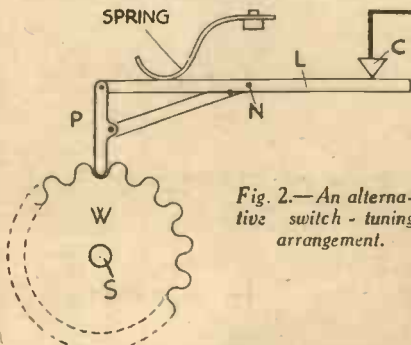

Fig. 2.—An alternative switch-tuning arrangement.

is short-circuited. Now the resistance may form part of the existing A.V.C. line in the set, and it may be associated with any one of the valves, either H.F. or L.F., but in any case it normally carries sufficient grid-biasing current to render inoperative the particular valve to which it is connected. This will obviously block the signal-channel and so prevent any sound from getting through to the loudspeaker.

COMPONENTS



The New Components Shown on This Page Are a Few of Those Culled from Our Artist's Sketch Book. The Sketches Were Drawn at Radiolympia.

FOR CONSTRUCTORS

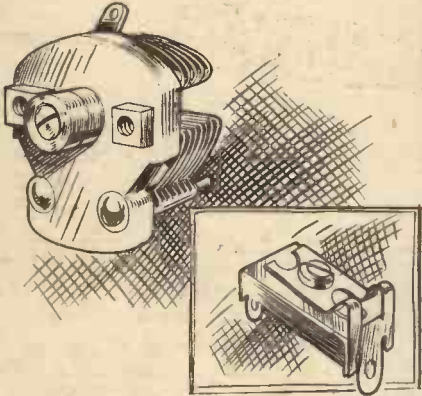

Two neat Polar accessories. Above is an air-dielectric trimmer, and below it a mica-dielectric one. They can be used for a variety of purposes in either broadcast or short-wave sets.

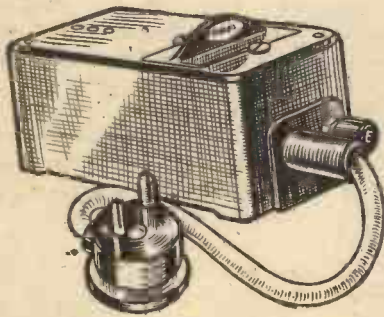

An effective interference suppressor for fitting in the mains lead to the receiver. It is made by Belling and Lee.

One of the Wearite iron-core intermediate frequency transformers is shown below with the screen removed. It can be obtained for either 110 or 465 kc/s.

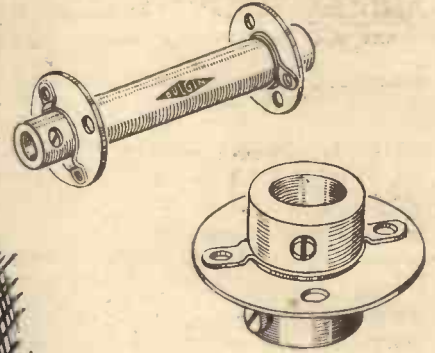
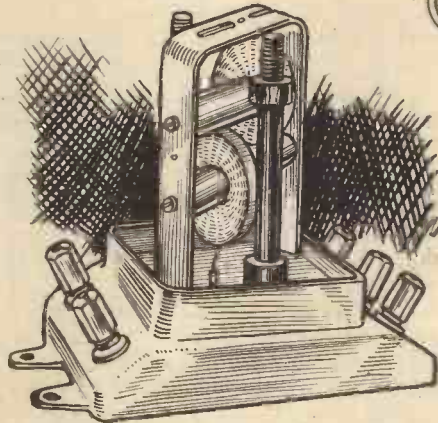

The new Bulgin flexible 1/4 in. shaft couplings which will couple all 1/4 in. diam. shafts with several degrees of flexibility. The type above has 1 in. or 2 in. porcelain insulators suitable for high-voltage work. With 1 in. long insulator the price is 1s. 9d. The other type (all metal, as illustrated) is priced at 9d.

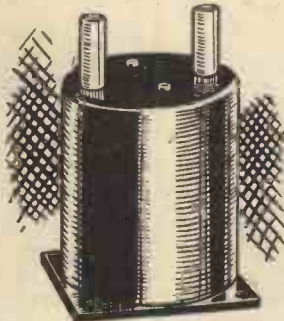

Above is the Lissen "Luxfilter," a special wave-trap for preventing break-through of Droitwich on the long-wave band.

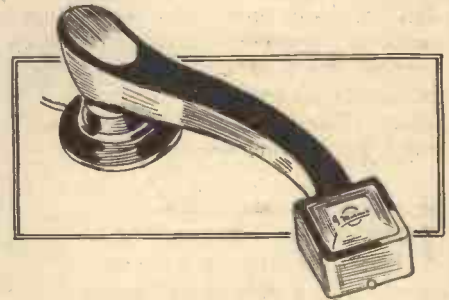

The Model 25 Marconiphone pick-up is illustrated above. This neat and sensitive unit is listed at £1 12s. 6d. Below is shown the Bulgin aerial lead-in insulator, which is adjustable for varying wall or window-frame thicknesses. It can be used with all types of aerial.

The Multitone "Adaphone" is on the left. It enables deaf people to listen to the radio programme. A special feature is an automatic volume check, which prevents the listener from being startled if the volume control is turned full on.

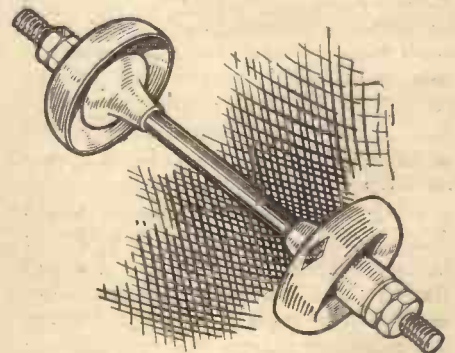
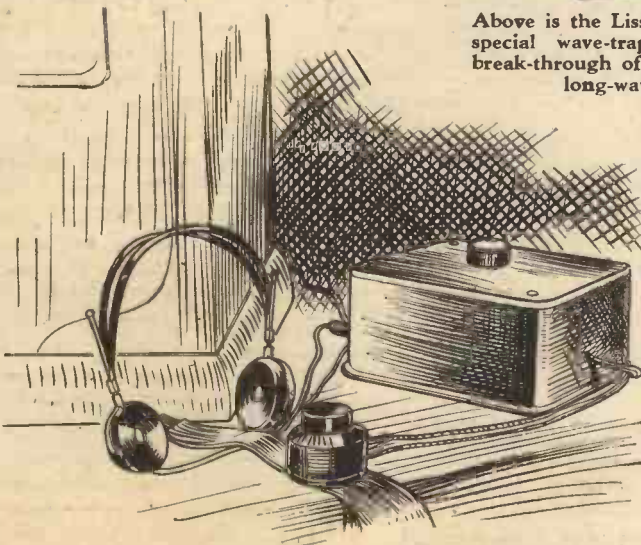



On Your Wavelength

By THERMION

More News from the Dailies

A FRIENDLY correspondent sends me a cutting from one of our leading daily papers. The cutting, which has a special black rule all round it to give it prominence, deals with a new non-magnetic ship, and I learn that the Admiralty is to construct a non-magnetic ship to replace the *Carnegie*. The hull will be of teak, bronze and brass, in place of iron and steel; she will have bronze anchors and cables, and the engine and dynamo will be of bronze and other non-magnetic alloys. Now I think the G.P.O. ought to know about this new dynamo, for here is the solution of the wireless interference problem. Isn't it funny how these daily paper wallahs discover new inventions almost every day, whilst we mere technical journalists are kept in the dark. Many thanks, H. J. P. (Edmonton), for sending the cutting along.

Baseboard versus Chassis

I HAVE had a number of letters from readers as a result of my recent paragraph that baseboard sets were out of date. I naturally expected to get them, but I am quite unrepentant in my point of view. However, I will let J. E. M., of Scarborough, have his say.

"A paragraph in your current issue tells of a man who prefers baseboard to chassis construction, and I agree with him. I have been constructing sets, from simple 2-valvers to 8-valve superhets, for ten years and never had a failure, and there is no question at all in my own opinion that for ease of construction and the ability to be able to make any alteration or modification at any time and quickly the baseboard wins every time. Just lift the lid and there you are. Your second paragraph states that 'Judging from circulation figures, sets are not being built to the same extent as

hitherto'. The reason is obvious, from my own experience, and in conversation with friends they one and all plump for baseboard. Early this year I assembled the Hall-Mark Four battery version as per blueprint on a chassis and the results were very good, but I couldn't get at it without dismantling the whole thing. So I built it again on a baseboard, with the result that the set was about four times more efficient and better in every way. To satisfy myself I put it back in the chassis, and it was exactly the same as at first. I now have it back on the baseboard and there is no doubt at all of the difference in performance which is simply great. All this, of course, is my own experience entirely."

Now what do you think of that—four times as efficient! Whatever are our manufacturers going to do about that? They have been wasting their time all these years making expensive chassis, when all they need have done was to have employed a piece of cheap plywood; but, of course, this reader is not serious. He is drawing the long bow in order to gain a point. Quite frankly, I do not believe him when he says that a receiver is four times as efficient on a baseboard. It will be interesting to know how he measures efficiency. He probably thinks because he gets one station at greater strength when using a baseboard, and losing twenty others obtained when using a chassis, he has obtained a more efficient set. Notice that he gives no formula by which he has judged the efficiency of the receiver. Such a statement as he makes is sheer nonsense.

Another in Favour

HERE is another letter from (Bedford Park):—

"I note your remarks re chassis-baseboard sets. Speaking as an amateur of over twenty years plodding, I most certainly agree with your

reader. I have built at one time or the other dozens of sets from various published designs, and can vouch for the ease of wiring, testing out for faults, and the ease with which a component is moved to cure interaction. This, I think, warrants the baseboard style. Up against all this we have the chassis type, ideal from mass production views, but from the amateur point, very tricky to wire, check, and test out for faults. And now another little moan, while I am about it; the majority of wireless amateurs, I believe, are like myself not blessed with too much "dough," and when you have been building for a few years, you find that the collection of spare parts begins to get unwieldy. Now it is not much satisfaction to buy PRACTICAL AND AMATEUR WIRELESS and find that the new set you would like to build requires new parts, none of your stock being usable."

And Another

THIS letter comes from a news-agent who says:—

"It is my job to sell, among other things, the leading wireless periodical, and I have been doing so for the past twenty years. During this time I have made friends with many 'Wireless Fans' and chatted regularly with dozens of others; my customers often speak of the difficulty of servicing chassis sets, and I am speaking the truth when I say scores prefer the panel.

"I certainly have a cabinet I paid a lot of money for; I have also gone to the trouble of fitting it out with a special baffle arrangement, and I am certainly not going to scrap it.

"I am prepared to admit that I am selfish, Dear Thermion; aren't we all? : are you not being selfish when you indulge in your vapourings about the "Crooner"? Granted I don't like them, neither do you, but that will never alter the fact that millions of others enjoy listening to them.

"You say you are open to be convinced, well, Thermion, I would like

to be the first to try to convince you, so why not meet me at any time or place to suit yourself and have a friendly chat on the matter. Should you be afraid of my learning your identity I've no objection to you wearing a mask or disguising yourself as the local policeman.

"I would like to add that I have always enjoyed reading 'On Your Wavelength,' and hope you will continue to write for us for many years."

About Television

HERE is a letter from H. S. B. (Llansamlet) :—

"You have the temerity to ask those interested in television to drop you a card to that effect. Your summer vacation must have done you good if you feel equal to coping with the volume of correspondence you are likely to receive. And you imagine the wireless fraternity will find itself equal to putting all it has to say on a mere 'card'?"

"Optimism is a cheery thing, but you're asking for it.

"However, here's my 'card' re this 'ere television.

"To quote my wife, I have 'messed about' with wireless since the crystal days, and spent enough on 'wireless bits' to enable me to buy several really posh outfits.

"However, true as the latter is, the whole point is that it is a hobby, and one expects a hobby to cost a little.

"Research, and so forth is, we know, expensive, but I would suggest that before (definitely not *after*, or television will be out of date) you have browsed among all the correspondence your rashness brings you, that you just pop round to the television component manufacturers—especially the 'toob' makers—and using plenty of blarney—and beer, you put forth the following :

"After a little back-chat you will bring up the subject of price.

"With every appearance of terminating the question, your manufacturer will tell you that costly research means a costly article. There may be a proviso : 'until the demand makes it cheaper.'

"Assuming you are tackling the 'toob' man first, you will point out that if the price of his 'toobs' is prohibitive, he won't sell any.

"'Now,' says you, becoming most persuasive and emphatic. 'If you sell these 'ere "toobs" of yours at a bob a time, every Tom, Dick, and Harry will have a television complex.'

"'Think of it! ; 450,000,000 listeners (millions in ratio to pints consumed) are eager for television. Big



Notes from the
Test Bench

Wattage Rating

A RESISTANCE - WATTAGE

problem appeared in our "Solve This" feature a few weeks ago. Readers were asked to calculate the required resistance in ohms and wattage rating required for a dropping resistance to be connected in the common anode lead of a mains receiver. It was stated that the current passing through the lead was 50 m.A and that a voltage drop of 50 volts was required. Several correct solutions were received—a resistance of 1,000 ohms with a wattage rating of 2.5 watts, or higher, was required. Many readers queried this solution, however, and claimed that the wattage rating should be 12.5 watts or higher. They calculated the wattage rating by multiplying the current by the total voltage across the circuit—this was stated to be 250 volts. This mistake is often made even by those who profess to be amateur designers. The total voltage does not enter into the calculation—the wattage rating is found by multiplying the current passed through the resistance by the voltage dropped across it.

L.F. Volume Control

AN L.F. volume control can be employed to advantage in most receivers. In sets using R.C. coupling between the detector and output valves the control can take the form of a 500,000-ohms or 1-megohm potentiometer. This should take the place of the fixed grid-leak in the grid circuit of the output valve. The coupling condenser should be connected to one end terminal of the control and the G.B.—lead to the other end terminal, the centre terminal being then joined to the valve grid. If transformer coupling is used, the end terminals of a 250,000-ohm potentiometer can be connected to the G. and G.B. terminals with the valve grid joined to the centre terminal. Another method is to use a potentiometer in place of the anode resistance of the detector or intermediate L.F. valve. Theoretically this is a better method than the connection of the control across the secondary of the transformer, but it is very difficult to obtain a potentiometer that is noiseless in operation when the anode current is passed through it. Grid controls are therefore much more commonly used.

business isn't in it! The chance of a lifetime!' 'Two pints!'

"Your factory will become fifty, the unemployment problem will be ended. Any man not working for "Boob's Toobs" will feel humiliation—prosperity will reign, and you—you will be hailed as the most discerning business man of the century, a benefactor of mankind. Your bank will have its vaults full to overflowing with your wealth and you will be "Sir Boob for the asking!"

"Two more pints, miss, please! '450,000,000 bobs is colossal; surely a mite of profit per article on 450,000,000 articles plus a knight-hood, reputation for big business, and wealth in abundance, is far better than trying to recoup your research costs on the first dozen "toobs"?"

"Well, Thermion, when you have accomplished this, we wireless 'fans,' 'experts,' 'twiddlers of knobs,' and so forth, will club round and buy you a 'pint.'"

Faulty Components

WHILST I am disposing of my correspondence, I should like to afford space to a letter I have received from S. D. (Forest Row) :—

"I am interested in television, so please add my name to your list of constructors for television receivers.

"I agree with your article re faulty components, as I have been in the same position myself, and would have given up wireless constructing, had it not been for the hints and tips which I have picked up through your paper. I have been a reader from (but you know the rest!), anyway, I built my first crystal set from the first number.

"Unfortunately, I did not manage a trip to 'Radiolympia' this year, but I had a chat with Mr. Camm last year on PRACTICAL AND AMATEUR WIRELESS Stand, and I agree with you that he seems always full of energy, always ready for any query.

"I say wholeheartedly that Mr. Camm is one of the best designers of radio; he's a great man!

"As for you, Thermion, I like you; I don't think you are 'stuck up'; some of your views I disagree with, and with others I agree. I don't like crooners, but still, everyone must get a living, even at the expense of spoiling some programmes! I always read your articles first, and I think you go a long way to making PRACTICAL AND AMATEUR WIRELESS what it is.

"May you live 'On Your Wavelength' long and die happy."

It is very kind indeed of this reader to make these complimentary remarks, which I reproduce just to prove that all the letters I receive do not contain brickbats.

BIRDMEN . . . through the Ages



Demonstration of the glider designed by Otto Lilienthal, gliding pioneer, who lost his life in one of his experiments.

THROUGHOUT the ages man has tried to fly like a bird. Only one has so far achieved real success—Clem Sohn, who recently evolved a new technique. The attempts of the earlier Birdmen make thrilling reading and are described in this month's PRACTICAL MECHANICS. The article includes some stirring photographs.

Other special contents of the October PRACTICAL MECHANICS include :

- A Midget 4-Wheeled Car with 2½ h.p. engine.
- Microphones Made at Home.
- How the Pneumatic Road Drill Works.
- Making a Rowing Machine or Trainer.
- Television Arrives.

THE OCTOBER

PRACTICAL MECHANICS

Of all Newsagents and Bookstalls, or by post 7½d. from the Publisher, George Newnes, Ltd., 8-11, Southampton Street, Strand, London, W.C.2.



George Newnes, Ltd.

**Do you smoke
NAVY CUT?**

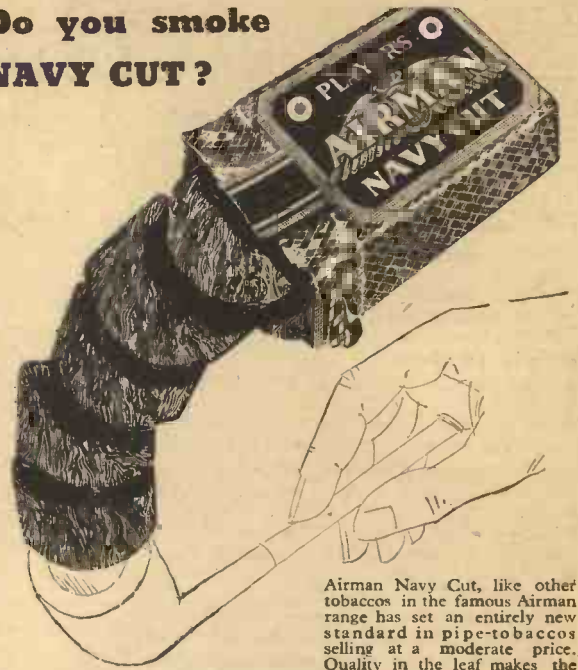

Airman Navy Cut, like other tobaccos in the famous Airman range has set an entirely new standard in pipe-tobaccoes selling at a moderate price. Quality in the leaf makes the value exceptional.

**PLAYER'S
AIRMAN
NAVY CUT**

ALSO OBTAINABLE IN MIXTURE OR FLAKE FORM

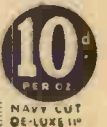

P.A. 48 C.

CLIX

All Clix components are designed and built so that the public can rely upon them for perfect contact, plus long and faithful service.

The 1936-7 range of Clix Valveholders includes the well-known Standard type and the new Floating type with frequentite base. Both are for chassis mounting and can be used with equal efficiency for metal chassis or wood baseboards. Then there is the baseboard type for Ultra-Short-wave work and the special Clix chassis type for use with Mivac Midget valves.

The illustration shows the new Floating type. All types employ Clix patent resilient, helically slotted sockets, which give perfect contact with any type of valve-pin.

You can rely upon Clix for long and faithful service. Send for Folders "N."

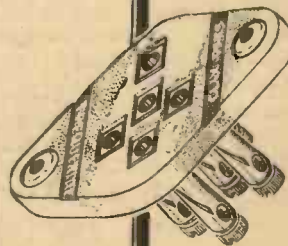

Clix are specified for the
"LIMIT ALL-WAVE 4"
described in this issue.

Yours faithfully

LECTRO LINX LIMITED

79A ROCHESTER ROW. LONDON S.W.1

The New Cossor 5-valve Superhet

An Efficient Battery-operated 5-valve Superhet
Embodying the Latest Refinements

THE demand for a really high-class battery receiver is as evident to-day as ever, and should ensure a welcome for the recently introduced Class "B" battery superhet by A. C. Cossor, Limited.

This new superhet (Model 376B) makes use of five valves in an interesting and very sound circuit arranged so that the utmost efficiency is derived from each stage. A two-circuit tuned aerial coupling is used between aerial and the first valve—Cossor 210PG Pentagrid—and is arranged to give sensibly constant efficiency over the whole of both wavebands.

The 210PG Pentagrid functions in the usual manner as a frequency changer, and by virtue of its special design it renders the receiver inherently free from modulator harmonics, and, in addition, allows of a considerable stage gain which is a valuable contribution to the overall gain of the receiver. The Pentagrid is coupled by means of the usual I.F. transformer to the intermediate-frequency amplifier, a Cossor

reason for the 220DD being indirectly heated, bearing in mind that it is essentially a 2-volt battery valve. The inclusion of the cathode is to permit the A.V.C. system to be delayed to preserve sensitivity on the weak signals, an arrangement that would not be practicable using a directly-heated valve. The advantage of delay is exceedingly important and brings the A.V.C. system of the battery superhet into line with normal mains receiver practice.

It is interesting to note that, although the pick-up is fed into the I.F. stage, the circuit is so arranged that the radio volume control associated with the diode on radio also functions on gramophone reproduction, obviating the necessity for a separate pick-up volume control.

The Driver and Output Stages

Next comes the driver stage, which employs the Cossor 220PA, which has a very high slope of 4 mA/v., giving a degree of sensitivity not normally associated with this stage.

Finally, the output stage employs the Cossor 220B, a zero bias Class "B" valve giving volume up to 1 watt, which it delivers to a well-designed permanent magnet moving-coil speaker having characteristics specially arranged so that the 220B works under the most favourable conditions.

Considering that this receiver is a superheterodyne with generous output, it is surprising that the H.T. consumption should be as low as we have found it to be, a matter of 12 mA average current with a quiescent current of approximately 9 mA.

The chassis is of the usual robust nature associated with this manufacturer's products, and is contained in a pleasing walnut cabinet of the upright type. There are only three controls—tuning, volume, and four-position switch for long wave, medium wave, gramophone, and off.

Performance

We found the receiver to be delightful to handle, both wavebands being entirely free from any serious whistles. Sensitivity on an average aerial was of a very high order, and the set is capable of logging any worth-while European stations, over forty stations being tuned in on the medium waveband in a single evening.

The performance on long waves is satisfactory, and selectivity is above the average, it being possible to tune in Luxembourg quite free of interference. On medium waves the selectivity is particularly good, and tuning slightly flat-topped, making critical tuning unnecessary. The scale,

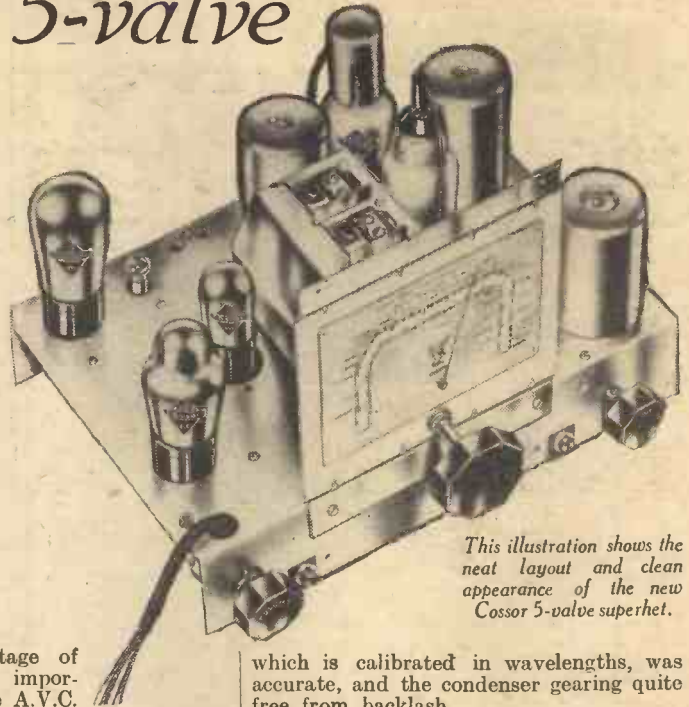

This illustration shows the neat layout and clean appearance of the new Cossor 5-valve superhet.

which is calibrated in wavelengths, was accurate, and the condenser gearing quite free from backlash.

The quality of reproduction is particularly good for a battery set, and equal to that of many mains-driven instruments.

Speaking generally, this receiver is robust, well made, well designed, and gives an excellent performance. It possesses adequate accommodation for a suitable accumulator and high-tension battery, provision for extension speaker and, of course, for pick-up, and for a receiver of such specification and performance the price of £8 18s. 6d. may be regarded as being very moderate. It may be purchased on hire-purchase terms for 14s. deposit and twelve monthly payments of 15s. 9d., or 14s. deposit and eighteen monthly payments of 11s. 3d.

SPECIFICATION OF MODEL 376B

Seven-stage Superhet circuit with automatic volume control employing 210PG frequency changer and 210VPT H.F. Pentode I.F. amplifier, 220DD Double Diode detector, High-slope power driver and Class "B" output. Single-knob tuning, 4-way switch. Volume control. 8in. permanent magnet moving-coil speaker, inlaid walnut cabinet, 19½in. by 14½in. by 11½in. Full-visual scale, calibrated in wavelengths and station names. Accommodation for accumulator and battery, plug and sockets for extension speaker and for pick-up.

TUNING DEVELOPMENTS

(Continued from page 69)

but breaks away from it each time the plunger rides over one of the teeth on the wheel W.

The contact C may be arranged at any convenient point in the circuit between the aerial and the loudspeaker. Signals can therefore only pass through the chain of valves so long as the contact C is closed, or, in other words, when the tuning-control is set to a desired station and the plunger P is engaging one of the slots as shown.

But directly the tuning control is moved from the precise tuning point so that the plunger begins to ride over one of the teeth, the contact C is broken, and the loudspeaker is automatically muted. The step-by-step control allows the listener, in effect, to switch rapidly and "noiselessly" from one station to another over the whole range of the set.



The new Cossor superhet in its handsome cabinet, showing the full-vision dial with station names.

210VPT. This valve acts as an L.F. amplifier also when the receiver is switched for gramophone reproduction; this ingenious arrangement is made necessary as a diode is used as second detector, making it impracticable to introduce the pick-up into this stage as is common practice when a second detector uses a triode multi-electrode valve.

Indirectly-heated Double-diode

The third valve—Cossor 220DD—is an indirectly-heated double-diode acting as signal detector and rectifier for automatic volume control. The A.V.C. voltage thus developed controls the signal grid of the pentagrid as well as the control grid of the I.F. amplifier. Both valves, of course, enjoy variable- μ characteristics.

Perhaps it would not be out of place to take this opportunity of explaining the

A PAGE OF PRACTICAL HINTS

SUBMIT YOUR IDEA

READERS WRINKLES

THE HALF-GUINEA PAGE

Variable Aerial Coupling

I HAVE been using this variable aerial coupling arrangement on a short-wave aerial with very good results. The sketch

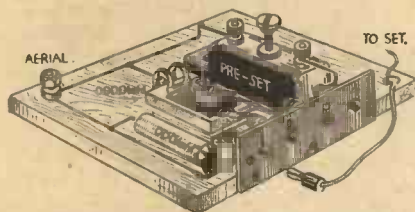

A simple variable aerial coupling arrangement.

is self-explanatory, the condensers and terminal strip being mounted on a sheet of ebonite 5 1/2 in. square. With this arrangement there is a choice of 4 plug-in points, one connected direct to the aerial, and the others putting condensers of varying values in series with the aerial.—J. J. STOREY (E. Baldon).

An Efficient Coil Former

THE coil former shown in the accompanying sketch is made with a bakelite torch case 1 1/2 in. diameter (approx.). The windings of the coil given here cover a wavelength in the region of 30 metres. I received Schenectady (W2XAF) on 31.48 m. at fairly good loudspeaker strength, the time being about 23.00. Of course, various

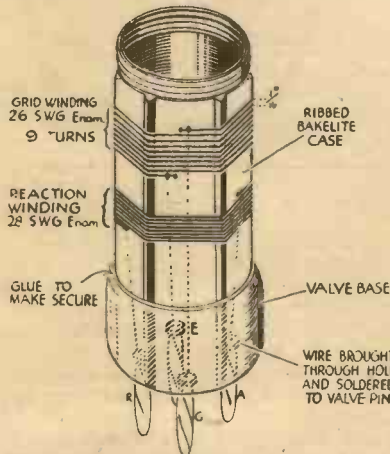

A coil former made from a bakelite torch case.

windings may be substituted to suit different requirements. One torch case will be sufficient for two formers.—S. W. DICKINSON (Willington).

A Novel Test Prod

THIS useful test prod can be made from an ordinary round metal torch case, bulb and battery. Remove the bottom part of the torch case, obtain a small brass strip, drill a hole in one end, and then bend it into a U-shape to form a spring contact. Next punch a small hole through a cork

THAT DODGE OF YOURS!

Every Reader of "PRACTICAL AND AMATEUR WIRELESS" must have originated some little dodge which would interest other readers. Why not pass it on to us? We pay £1-10-0 for the best wrinkle submitted, and for every other item published on this page we will pay half-a-guinea. Turn that idea of yours to account by sending it in to us addressed to the Editor, "PRACTICAL AND AMATEUR WIRELESS," George Newnes, Ltd., 8-11, Southampton Street, Strand, W.C.2. Put your name and address on every item. Please note that every notion sent in must be original. Mark envelopes "Radio Wrinkles." Do NOT enclose Queries with your Wrinkle.

which fits the case tightly, and pass a thin 1 1/2 in. set-screw through the spring and cork, and fasten with a nut. The set-screw should be ground to a point before slipping through the cork. Then solder about 18 in. of flex, which is fastened to an ordinary prod, to the top of the case, slip in the battery and insert the cork. The test prod is now complete and ready for use.—A. J. HOBBS (London, W.).

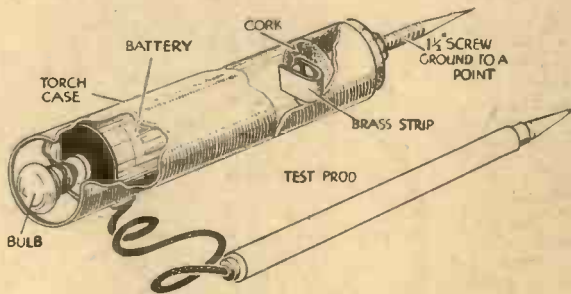

A test prod complete with battery and bulb.

Checking Wiring Connections

HERE is a dodge which has proved to be of great value for checking wiring connections, especially when constructing a "super" set. Take a piece of ordinary tracing paper and lay it over the diagram or

blueprint from which you are building a receiver. As each connection is made, mark it with a pencil on the tracing paper. When the diagram on the tracing paper

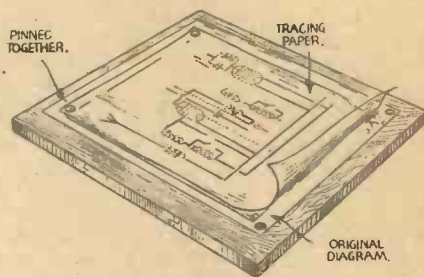

A method of checking wiring connections.

corresponds with the original, you know the set is correctly wired. This eliminates a lot of hunting for "lost" or "forgotten" wires and is invaluable in wiring complicated sets where a short connection may easily be overlooked.—ARTHUR JONES (Harrow).

A Soldering Dodge

I HAVE found when soldering, and when wishing to clean the iron, that often the work has to be stopped for a while. This is not always convenient, especially when the left hand is being used to keep something in "just the right position." I have overcome the difficulty by tacking a piece of "file cloth"

down upon the bench, and this does good service, its abrasive surface being ideal for cleaning purposes.—G. W. ARNOLD (Ilford).

Remote Drives

WHERE a large radiogram cabinet is in use and a form of remote control is desired in order to accommodate the receiver chassis in a more convenient position, the drives from controls mounted on the motor-board may be connected through standard bowden cables as supplied for cycle brakes. Connectors are soldered to the ends with locking screws for attachment to the component spindles and control knobs.—R. BIRCH (Hendon).

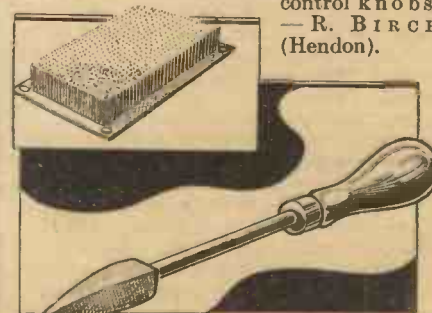

When soldering, this dodge will be found very handy.

A FINE BOOK FOR THE BEGINNER!

AND A USEFUL PRESENT

EVERYMAN'S WIRELESS BOOK

(2nd Edition)

By

F. J. CAMM

3/6 or 3/10 by post from Geo. Newnes, Ltd., 8-11 Southampton Street, Strand, London, W.C.2.

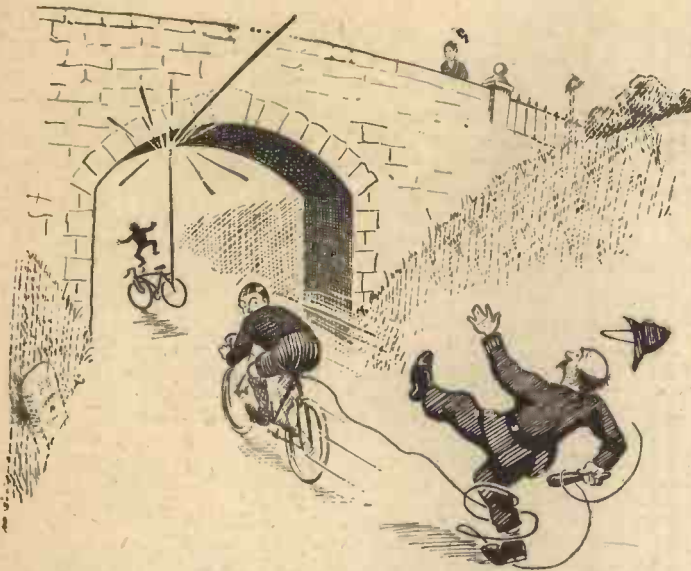

Two alternative suggestions for carrying an aerial, both of which may lead to trouble.

RADIO FOR CYCLISTS

By C. R. PROBERT

A Tame Humorist Gives Some Useful Suggestions for Combining Bicycles with Kilocycles

(Reprinted from "The Cyclist," September 16th issue)

A GREAT deal has appeared in the Press lately about car-radio, but nothing seems to have been said about cycle-radio, so I have designed a special set and compiled the following notes for the benefit of those who wish to combine bicycles with kilocycles.

The days of the crystal-detector are past, and valves are now essential for reception. A bicycle already has two—one in each tyre, but these are useless for radio purposes. The kind you need are what our American friends call "toobs." I know you already have two of these as well, but they won't do either, so go to the nearest radio dealer and ask for a couple of wireless valves.

A Simple Circuit

I have worked out the simple circuit you see printed here, and I think you will agree that it looks appropriate. The theoretical diagram (copies of which cannot be obtained by sending a postal order for 6d. to the editor of *The Cyclist*) is almost self-explanatory and the construction of this simple set will present no difficulties to any cyclist who can wield a tyre-lever and a slide-rule. A few supplementary notes may, however, be helpful.

As you might expect, the leaky grid system of detection is employed. While self-lubrication is popular with some cyclists, it is not advisable for your grid to be too leaky, and a small condenser may be necessary in order to condense the fluid. Or perhaps a patent washer of the oxy-soda variety.

A "Frame" Aerial

The frame of the cycle itself is used as an aerial. I know that this is open to the drawback that it is apt to be highly directional so that, while traversing our winding English roads, readers may find the set delivering scraps from the programmes of a series of diverse stations as the machine swings from north to west and so on; but the only alternatives are either to carry a 20ft. steel mast or to trail a length of insulated wire from one's saddle—proceedings which may lead to trouble with other road users.

Keen observers will notice that no earth return is shown on the diagram. Except when bumped off by motors or other goad parasites, cyclists avoid an earth return

to be at the rear of the machine, but can be fitted anywhere convenient) can, by a simple modification of the wiring, be utilised alternatively as a horn for giving warning of one's approach or (if you add a microphone) as a means of loudly conveying to offensive (and rapidly

whenever possible, hence its omission from the circuit.

The Loudspeaker

The loudspeaker (which appears from the diagram from the diagram

race away at high speed, with a consequential appalling increase of volume. The broadcasting cyclist, therefore, must curb any tendency to swing his feet in time with the tune if he wants steady volume of sound.

Track Racers

In conclusion a few notes about the effect of radio upon the efficiency of cyclists may be useful.

As I have hinted above, an intensive ration of hot jazz or of the more cacophonous works of modern composers like Stravinsky or Bartok might be extremely beneficial in stimulating track racers to

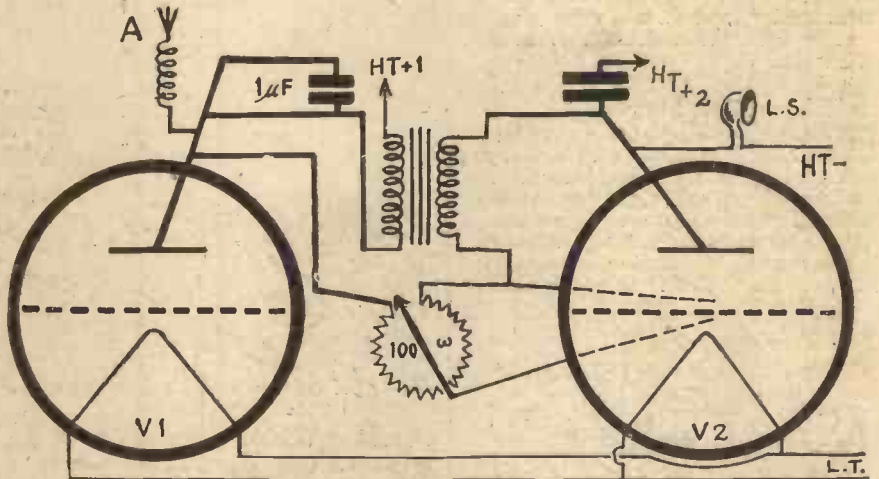

The circuit diagram, which may or may not prove self-explanatory. The set should present no difficulties to the constructor providing that he does not use rubber solution for fixing the wires. A tyre-lever is recommended for this part of the construction.

departing) motorists one's opinions of their road-sense, character and antecedents.

It is unnecessary to bias the valves, in fact, any bias one way or the other may lead to instability and loss of balance, a thing no cyclist wants.

The high-tension supply (of one-moke power) is obtained from the lighting dynamo driven by the propulsion system of the cycle. If signals grow weak the remedy is to pedal faster.

A Warning

In this connection a warning is timely. Music-loving cyclists may be tempted during the broadcast of a dreamy lullaby to reduce the number of foot revolutions per minute in synchrony with the lilt of the melody. The result will be fading of the music from the loudspeaker. Conversely, during a patch of hot jazz the rider may be inclined to go berserk and more frenzied efforts—though this raises

the question whether doping of this kind is permissible under the rules of clean sport; but such a programme might be dangerous on the public highway. There are few radio comedians capable of causing such extreme mirth as to make a rider lose his balance, but we all have our pet items, and it is possible that a lover of, say, the Foundations of Music, might become so absorbed in one of the damp courses as to grow oblivious of the surrounding world—with disastrous results.

I fear that the courts are unlikely to accept the excuse that the cyclist's attention was temporarily distracted by an absorbing talk on Road Surfaces in Ruritania as an adequate plea for riding down a decrepit Austin Seven.

LATHE WORK FOR AMATEURS

By F. J. CAMM.

1/- or 1/2 by post from

GEORGE NEWNES, LTD., 8/11, Southampton St. Strand, W.C.2.

Practical Television

October 3rd, 1936. Vol. 3. No. 18.

TELEVISION PROGRESS IN GERMANY

THE design of television receiving sets in Germany appears to be following on somewhat similar lines to that in this country. The cathode-ray tube in one of its several forms is almost exclusively used as the picture reproducer, and the pictures shown on these sets, especially

mental television service now being radiated. Actual adjustment is confined to two double knobs about a third of the way up from the base of the trunk-like cabinet. The range of wavelengths covered is from 5.5 to 7.5 metres so that it is possible to receive the television transmissions from both Witzleben and Brocken. Only one aerial is required (as in this country) for both sound and vision signals, so that the external connections are confined to leads from aerial, earth, and A.C. mains. In this model the picture is observed directly on the screen of the cathode-ray tube, being black and white in colour and having picture frame dimensions of approximately 9 inches by 7.5 inches.

Indirect

A larger type receiver is featured in Fig. 1, this giving a picture size of approximately 14 inches by 12 inches, which is about two and a half times the area of the first picture. Using a large cathode-ray tube of this type, capable of giving very brilliant pictures, the set can be used for demonstrations to large audiences, the picture being made visible by reflection in a good quality mirror located in the cabinet lid. This particular set was

designed to receive pictures with consecutive or interlaced scanning, and a number of them were on show for portraying the results of the transmissions from the G.P.O. television car, the electron camera, and the disc type telecine scanner. This last named apparatus was built and shown by Fernseh A.G., the standard of definition being one of a total of 375 lines 50 frames per second, interlaced to produce a flickerless picture repeated as a complete scan 25 times per second.

Projection

Last year a large projection type receiver was shown at the Berlin Radio Show based on the intermediate film method. The received picture built up on the screen of a very brilliant cathode-ray tube was photographed in a special type cine camera. The film was then led through tanks so that at the end of a period totalling approximately 1½ minutes this film had been developed, fixed, and dried. A standard form of cinema projector then projected the individual film pictures on to a distant scan about 10 feet by 8 feet in size. This actual apparatus is still functioning in the television room of the Berlin Post Office, N.W.21.

This year, however, a projection receiver of quite a different type was featured by Fernseh A.G. It is shown in Fig. 3 and the "heart" of the set is a small cathode-ray tube with a screen less than four square inches in area. Using a very high anode voltage the picture produced is small, but so brilliant that it can be projected and

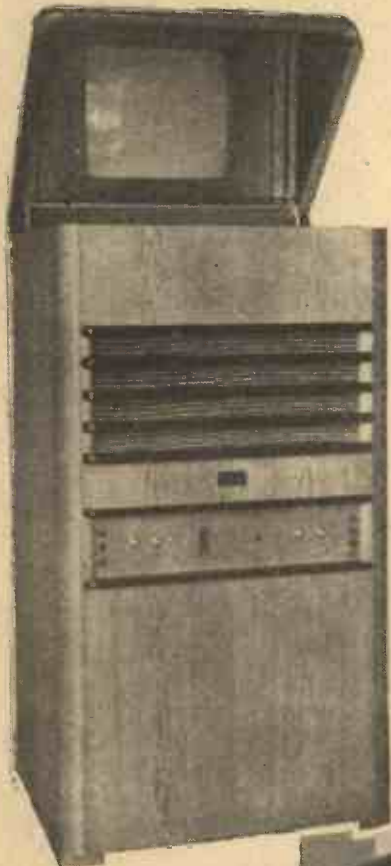

Fig. 1 (above).—An indirect viewing German television receiver.

Fig. 3 (right).—A projection type C.R. tube receiver built by Fernseh A.G.

during the course of the Berlin Radio Exhibition, were particularly good.

Direct

As an example of one type reference can be made to Fig. 2. This is characterised by an extremely well-made cabinet with bold design, while the set itself is noteworthy for the extreme simplicity of operation. Compared with sets in this country, this easy manipulation of the controls and associated circuits is due to the absence of two standards of definition in the experi-

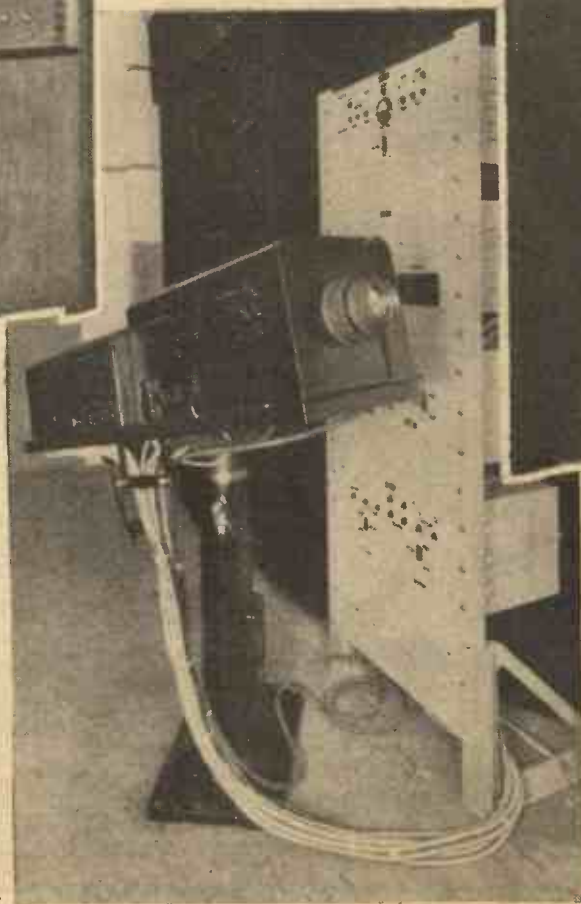

Fig. 2.—An example of a direct-viewing German television receiver.

focused on to a distant screen. The lens employed for this purpose is seen clearly in Fig. 3, and the picture shown with this equipment was approximately 4 feet by 3 feet. Receivers of this nature are adapted admirably for the portrayal of television pictures to quite large audiences and the results achieved so far are very promising. A scheme of this nature is a direct reply to those protagonists of mechanical methods who state that projection pictures of good size and quality are impossible without some form of mechanical-optical mechanism.



Cover 5,000 miles Range-

"LIMIT" ALL

F. J. CA

AS I pointed out last week this receiver is designed to cover four separate and distinct wavebands. Many so-called all-wave receivers now in use do not take full advantage of the short waves and include only one short-wave band, generally of rather narrow width. In the "Limit" the short waves are spread over two separate bands, the lower ranging from 13-26 metres and the upper from 25 to 55 metres. In addition to these bands, of course, the usual medium- and long-wave broad-

effected at two points. These will be dealt with in the following operating instructions. When the receiver has been completely wired, by following the Free Blueprint which was presented with last week's issue, the batteries should be joined up, connecting the lead marked H.T.1 to a point about 60 volts positive, and H.T.2 into the 120-volt socket. The L.T. leads are, of course, joined to the respective positive and negative terminals, and the G.B. positive socket is inserted into the positive socket of the G.B. battery. G.B.1 is inserted into the 1.5-volt socket, G.B.2 into the 7.5-volt socket, and G.B.3 into the 9-volt socket, and when the aerial and earth leads are plugged into the A.E. socket strip the receiver is ready to feed the loudspeaker, which should be the W.B. Junior and which

Further Notes on Construction and Operating Receiver Designed to Cover

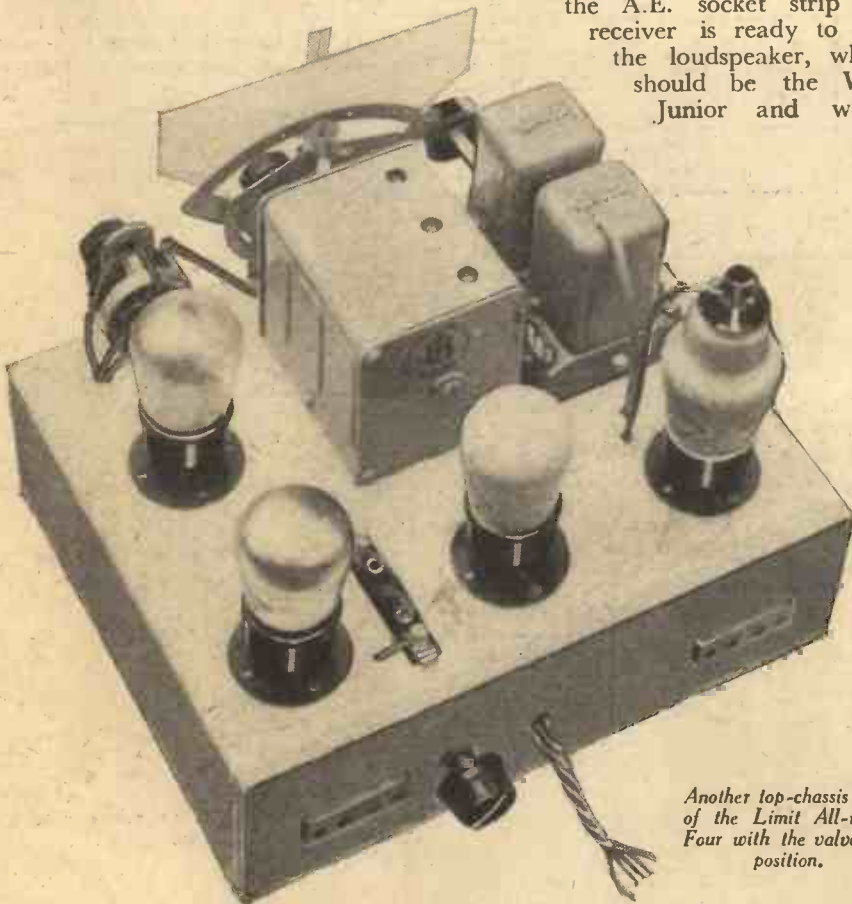

Another top-chassis view of the Limit All-wave Four with the valves in position.

cast bands are covered in the usual manner, the medium-wave range extending from 180 metres to 550 metres, and the long-wave range from 750 to 1,950 metres. All tuning is carried out on the central knob, whilst wave-changing is

is plugged into the L.S. socket strip.

Tuning and Operating

When the right-hand upper control is turned to its maximum position in an anti-clockwise direction the set is

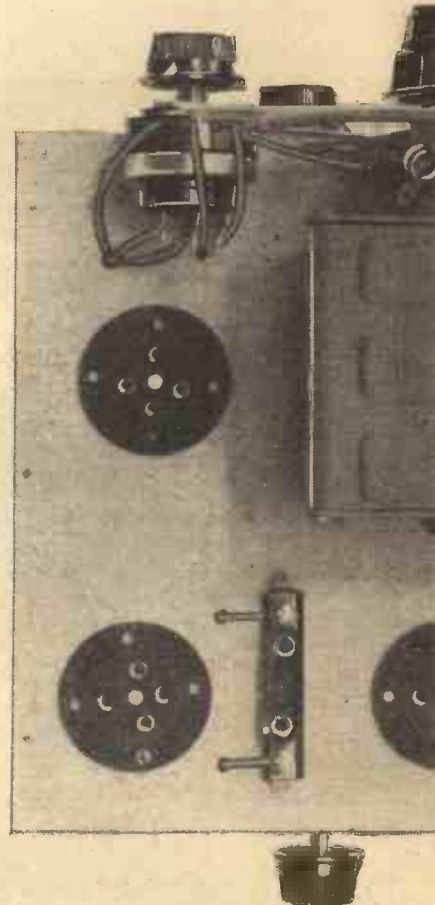

This plan view of the chassis

switched off. For the preliminary test-cut the rear control should be turned to its maximum position in a

LIST OF COMPONENTS FOR F. J.

- Two-gang coil unit, type PIC-TIC (Wearite).
- Three-gang condenser—one .0005 mfd. (C1), two .00025 mfd. (C2, C3) (J.B.).
- Slow-motion drive, type S.L.11 (J.B.).
- Differential reaction condenser, .0003 mfd. (C4) (Polar).
- Multi-switch, type S223 (B.T.S.).
- Potentiometer, 50,000 ohms, type VM60 (R2) (Bulgin).
- Potentiometer, 500,000 ohms, type VC63 (R7) (Bulgin).
- Two-range short-wave coil (B.T.S.).
- Short-wave H.F. choke (B.T.S.).
- Six fixed resistances: 1,000 (R4), 20,000 (R6), 75,000 (R5), 100,000 (R8), .5 meg. (R1), 2 meg. (R3), 1 watt type (Dubilier).

CAMM'S All-wave 4

Instructions for this New Battery All-wave
Four Separate Wavebands



Chassis shows the clean layout.

clockwise direction and this will then ensure that the L.F. circuits are fully loaded. Turn the lower right-hand

Without Coil Changing

control to its maximum position in a clockwise direction, and set the control pointer to its approximate setting according to your local station. Thus, if you are in the London area, the pointer should be about the centre of the scale; in the Northern area to a point about three-quarters of the way along the scale; for the Midland area to a point about one-quarter along the scale, and so on. Now turn the upper right-hand switch and after the click is heard the receiver will be in working condition, but the H.F. volume control which is operated by this control knob will be then at its minimum setting and will probably need to be turned to its maximum clockwise position. The control knob attached to the Wearite coils should then be turned until the local station is

strength to enable the station to be accurately tuned. The trimmers on C.2 and C.3 should then be adjusted for maximum response, the volume being reduced as a satisfactory build-up is obtained, to avoid overloading the output valve.

The L.F. Control

If it is found that even with the H.F. control at its minimum setting the volume is still too great, the rear control should be operated in order to limit the strength of signal applied to the output valve. To change to long waves the switch on the Wearite coils is operated, but to change over to short waves the lower right-hand control is operated, and when turned to the next setting, as shown by the "clicking" into position of the locking plate, the

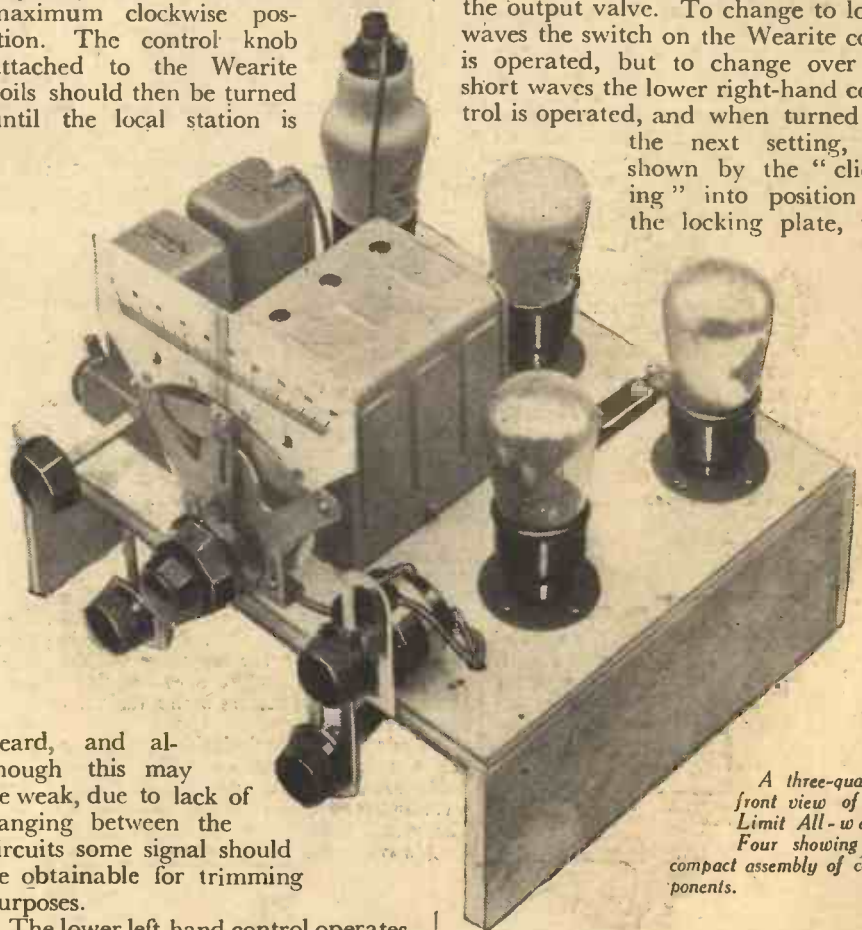

A three-quarter front view of the Limit All-wave Four showing the compact assembly of components.

heard, and although this may be weak, due to lack of ganging between the circuits some signal should be obtainable for trimming purposes.

The lower left-hand control operates the reaction condenser and this functions in two different directions, when turned one way the reaction is increased on the short-wave bands, and in the other direction, on the broadcast bands, and therefore this condenser should be operated to effect the necessary build-up in signal

receiver will be set for the upper of the two short-wave bands, and at the next position will be set to the lower short-wave band. The two volume controls are effective on all wavebands, and the rear control only limits the volume applied to the L.F. stages.

CAMM'S LIMIT ALL-WAVE FOUR

- Six fixed condensers: .0001 (C8), .0005 (C5), type 690W; .01 (C10), type 670; .05 (C7), .1 (C6), .25 (C9), tubular (Dubilier).
- L.F. Transformer, type Niclet, 3 1/2-1 (Varley).
- Four valve-holders, 4-pin, type V3 (Clix).
- Two terminal strips, AE and LS (Belling Lee).
- Five component brackets (Peto Scott).
- One Metaplex Chassis (Peto Scott).
- Seven plugs: H.T.2, H.T.1, H.T.—, G.B.+, G.B.—1, G.B.—2, G.B.—3 (Belling Lee).
- Two spades: L.T.+, L.T.— (Belling Lee).
- Four valves: 210VPT, 210 Det., 210 Det., 215P (Cossor).
- Speaker, type 37J (W.B.).
- 100 m.A. fuse and holder (Microfuse).
- 120 volt H.T. battery (Drydex).
- 9 volt G.B. battery (Drydex).
- 2 volt accumulator (Exide).

ABC of the Modern Receiver-2

NOW that a general description of the function of the main sections of a typical receiver has been given, we can proceed to study those functions more intimately. First is the aerial-input tuning circuit, by means of which the aerial-earth system is coupled to the first valve. As pointed out last week, the object of this tuning circuit is to select the frequency of the desired transmission and to reject all other frequencies. The tuning circuit consists essentially of a coil and a condenser, for these two components possess the properties of inductance and capacity, respectively. The combination, which is shown in Fig. 1, is known, technically, as an oscillatory circuit. This is because the oscillations comprising the signal frequency oscillate backward and forward between the condenser and the inductance coil.

Coil to Condenser

As most readers know, when an electrical current is passed through a coil, the coil becomes a magnet. Thus, as the signal current passes through the coil a magnetic field is set up around it. The condenser then comes into play, and the magnetic field is again changed into an electric current, which charges the condenser. This is because a condenser has the property of "storing" electricity. But by the time the condenser has become charged the next "wave" of the signal has come along and again caused a magnetic field to develop round the coil. This is assisted by the current flowing back from the condenser when it "discharges." Briefly, the result is that current flows backward and forward between the condenser and the coil. And when the correct values of capacity and inductance have been chosen this backward and forward flow is "in time" with the backward and forward signal currents. When this condition obtains

the circuit is said to be "in tune" with the transmission, because the oscillatory circuit "traps" the signal, instead of allowing it to flow through the coil to earth.

Since we are not attempting to explain in detail the precise theory of the system,

The Aerial Tuning Circuit is Explained in Greater Detail, and the Question of Selectivity is Dealt With

we can let the matter rest at that, simply pointing out that when the system is properly tuned and the signal is "trapped" the maximum voltage is produced between the ends of the tuned circuit. Obviously,

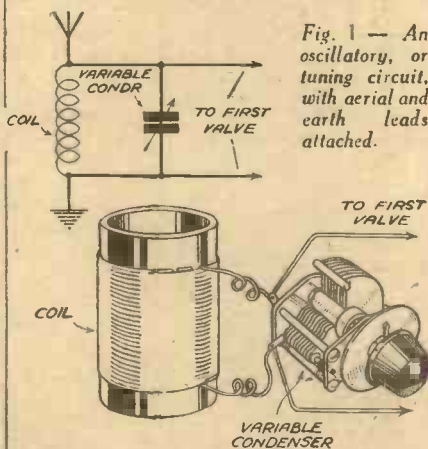

Fig. 1 - An oscillatory, or tuning circuit, with aerial and earth leads attached.

this will cause the greatest high-frequency voltage to be applied to the valve which is connected to the circuit. This, in short, is the condition which must apply if maximum signal strength is to be obtained from the loudspeaker.

Resonant Frequency

In order to alter the resonant frequency, or tuning point, of the coil-condenser combination we may change either the inductance or size of the coil, or the capacity of the condenser. In practice it is easier to alter the capacity of the condenser, and therefore a coil of fixed size is used in conjunction with a variable-capacity condenser.

At this point it is desirable to refer to the simple mathematical relation that holds between inductance, capacity, and wavelength to which the circuit is tuned. The relation is given by the formula:

$$\lambda(\text{wavelength in metres}) = 1,884\sqrt{L(\text{inductance in microhenries}) \times C(\text{capacity in microfarads})}$$

In words, this states that the wavelength to which the circuit tunes is equal to 1,884 multiplied by the square root of the product of inductance and capacity. The usual medium-wave coil has an inductance of 157 microhenries, and .0005 mfd. is a standard capacity for the tuning condenser. Those who wish to work out the equation will find that the maximum wavelength which can be reached with this combination is approximately 560 metres.

In the same manner it can be found that the highest wavelength reached when using a long-wave coil with an inductance of 2,100 microhenries with the same condenser is about 1,900 metres. In order to obtain a coil which will cover both medium and long wavelengths (roughly 200 to 550 metres and 900 to 2,000 metres) it is necessary to wind it in two parts so that either the whole or one section can be used. Because of this we use a wavechange switch, this being connected as shown in Fig. 2 between a tapping on the coil and one end of it. The switch merely short-circuits the long-wave winding when its contacts are closed, so putting that portion out of action.

Increasing Selectivity

In Figs. 1 and 2 we have shown the aerial lead-in attached to one end of the coil and the earth lead attached to the other. Although this is quite practicable it is seldom done, because the aerial exerts what is known as a "damping" effect on the tuned circuit, causing it to be less selective. The reason is that there is capacity between the aerial and earth—the two forming a condenser—which allows a certain amount of "leakage" of the signal voltages. This condenser is not an efficient one, but it also has the effect of altering the wavelength to which the coil and condenser would tune if it were not attached.

One method of reducing the effect of this "stray" capacity is by including a fixed or variable condenser in series with the aerial lead-in, as shown in Fig. 3. Being in series with the aerial it reduces the capacity of the latter across the coil. To understand this it must be known that the resultant capacity of two condensers in series is less than the capacity of either by itself. Without at this stage giving

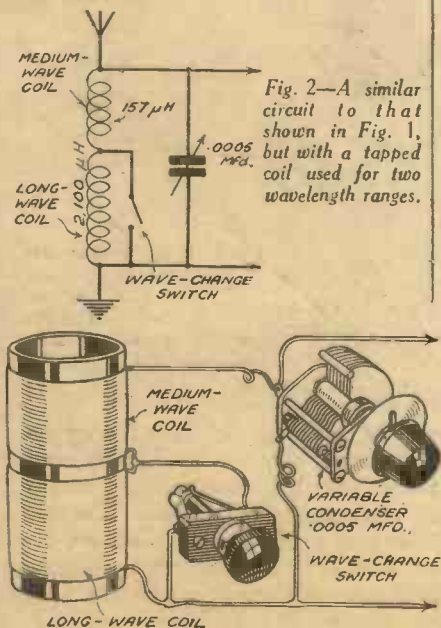

Fig. 2—A similar circuit to that shown in Fig. 1, but with a tapped coil used for two wavelength ranges.

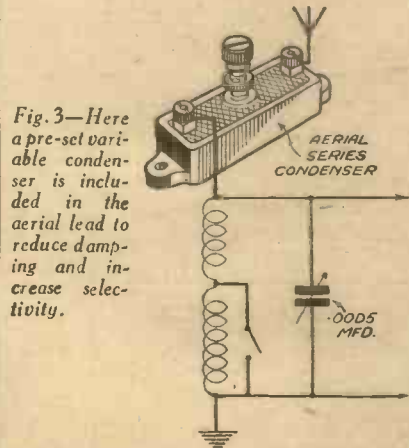

Fig. 3—Here a pre-set variable condenser is included in the aerial lead to reduce damping and increase selectivity.

the equation, it can be pointed out that when two condensers of equal capacity are in series, the resultant capacity is one-half the capacity of one of them. Thus, if the aerial-earth system had a capacity of .0003 mfd. (a fairly usual figure), and a .0003-mfd. condenser were inserted in series with the aerial lead-in, the effect on the coil would be the same as that of a .00015-mfd. condenser. In practice,

ABC OF THE MODERN RECEIVER

(Continued from facing page)

the aerial-series condenser is generally of .0001 mfd. (fixed) or .0003 mfd. (variable). The latter, using a pre-set condenser, is best for experimental use, since the most suitable capacity can be found by trial under working conditions.

A Tapped Coil

Another method of reducing the effect of the aerial "damping" is by joining the lead-in to a tapping on the coil, instead of to one end—often using the series condenser as well. This is illustrated in

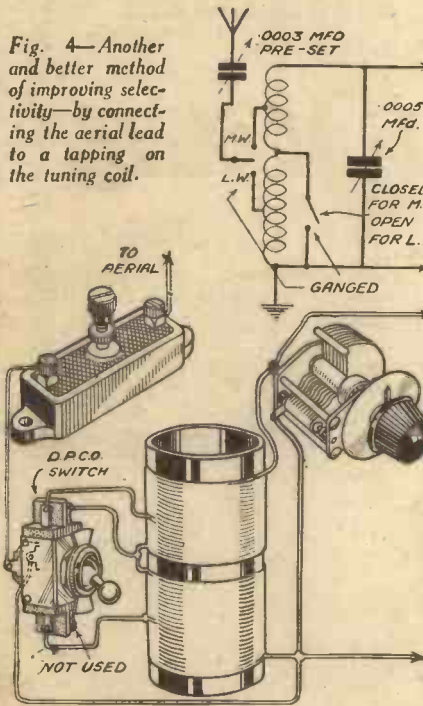

Fig. 4, where the aerial can be transferred from a tapping on the medium-wave winding to one on the long-wave section by means of a change-over switch ganged with the on-off-type wavechange switch. If the aerial tapping were half-way down the coil, the effective aerial capacity would be reduced by one-half. Thus, by using a .0003-mfd. series condenser, the aerial capacity would be reduced to one-quarter its normal figure; in the case quoted above, .000075 mfd. If the series condenser were reduced in value to .0001 mfd. the effect of a .0003-mfd. aerial would be negligible, being only the same as that of a condenser of .000037 mfd.

Another method of obtaining the same result is by using a separate winding for the aerial, as shown in Fig. 5. This is placed near to the grid or tuned winding, but it has fewer turns. In the example shown there are two separate aerial windings, one placed near the medium-wave tuned winding, and one near to the long-wave section. Additionally, a two-pole wave-change switch is used to short-circuit the long-wave portions of both coils when medium-wave reception is required. This is a popular form of construction in modern coils, and gives extremely good results when the numbers of turns on the aerial windings are carefully chosen.

Coil Turns

This is not a constructional article, but readers will better be able to visualise the coil if approximate details are given concerning the numbers of turns required for the various windings to give inductance values similar to those mentioned above. When using a paxolin or ebonite former of 1 in. diameter, approximately 90 turns of wire are required for the medium-wave tuned winding, and 250 for the long-wave section. About a third of these numbers can then be used for the aerial-coupling coils.

Screening

Most modern coils are screened by being enclosed in metal cans, generally made of aluminium, although copper can be used satisfactorily. The object of the screening can is to prevent the magnetic field which is built up round the coil from affecting other components, and wiring, in the receiver. If the field did reach to other coils and components there would probably be a loss in efficiency, due to the other parts "absorbing" a portion of the magnetic field. Additionally, these parts would produce a certain capacity with the coil and so upset tuning. In the same way, proximity of the hands of the set user would create a capacity to earth (the body being at earth potential). This capacity would vary with the movement of the hands, so that tuning would

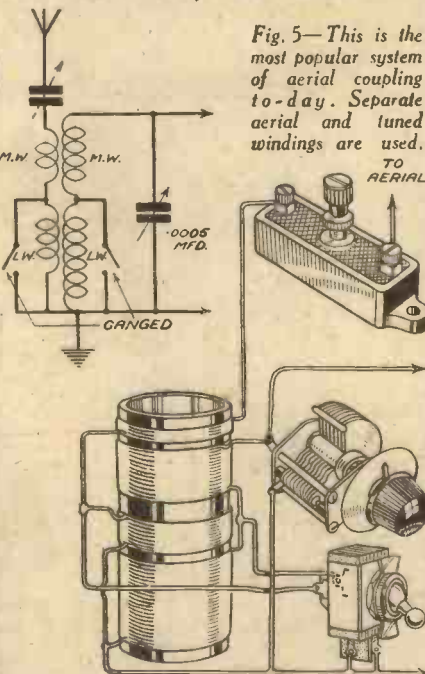

Fig. 5—This is the most popular system of aerial coupling to-day. Separate aerial and tuned windings are used.

again be upset, giving rise to what is commonly known as the "hand-capacity" effect. This is not usually very noticeable with a set tuned to the broadcast wavelengths, but is frequently pronounced in connection with a short-wave receiver. (To be continued.)

THE WIRELESS CONSTRUCTOR'S ENCYCLOPEDIA

By F. J. CAMM (Editor of "Practical and Amateur Wireless") 4th Edition 5/- net
Wireless Construction, Terms and Definitions explained and illustrated in concise, clear language.
From all Booksellers, or by post 5/6 from George Newnes, Ltd., 8-11, Southampton Street, Strand, London, W.C.2.

PETO-SCOTT

IMMEDIATE DELIVERY of 1937 models—Speakers, Eliminator, Kits, Pick-ups, Testing Meters, and all EKCO, McMICHAEL, COSSOR, BUSH, 1937 Receivers for CASH, G.O.D. or Easyway. Quotations for anything Radio on Request.

NEW AND DIFFERENT! Peto-Scott 1937 ADAPTOR CONVERTER KIT



KIT "A" 29/6

Cash or C.O.D. Carr. Paid. Or 2/6 down and 10 monthly payments of 3/-. Comprises all parts for building, with diagram, assembly, and operating instructions, less cabinet.

2/6 DOWN SEND FOR FULL DETAILS

Convert your existing Battery or A.C. set for operation on the short waves with this up-to-the-minute unit. No alterations to your set whatsoever. Two hours to build—a lifetime of world-wide entertainment. Consider these features:
● 13-80 METRES without coil changing ● Ready drilled steel chassis (grey enamel) ● Ready drilled steel panel (handsome black crystalline finish) ● Dual ratio aeroplane drive ● f-range short wave coil with rotary switch (silver-plated contacts) ● Air dielectric tuning condenser.

1937 STENTORIANS

MODEL 37J. Makes an unmistakable improvement in volume and realism of reproduction. Perfectly matches any receiver as principal or extra speaker.
Cash or C.O.D. Carriage Paid, £12/8. Or 2/6 down and 11 monthly payments of 3/-.
MODEL 37E. Highly efficient Baby Speaker with an adaptation of the famous "Microcode" matching device.
Cash or C.O.D. Carriage Paid, £13/6. Or 2/6 down and 10 monthly payments of 2/6. Any W.B. Model on attractive terms.

PETO-SCOTT Co. Ltd. 77 (Pr.W.3) CITY ROAD, E.C.1. West End: 02 (Pr.W.3), High Holborn, London, W.C.1.

ENGINEERS! ARE YOU EARNING LESS THAN £10 PER WEEK?

If so, you cannot afford to carry on without reading our 268-page Handbook. The book explains clearly and definitely many ways of carving out a successful career. Among other things it explains the Services of our unique Appointments Department, outlines Home-study Courses in all branches of Civil, Mechanical, Electrical, Motor, Aero, Wireless, "Talkie," Engineering, Building, Govt. Employment, etc., and gives details of B.Sc., A.M.I.C.E., A.M.I.E.E., A.M.I.Mech.E., A.M.I.A.E., A.M.I.W.T., A.M.I.R.E., G.P.O. MATRIC, and all Exams. We Guarantee—"NO PASS—NO FEE." Whether you be an old hand or a budding apprentice, get this book to-day—FREE and POST FREE. BRITISH INSTITUTE OF ENGINEERING TECHNOLOGY, 409, Shakespeare House, 17/19, Stratford Place, London, W.1.

RENEW YOUR VALVES DIRECT FROM MAKERS AT HALF PRICE

Not only will you save half your money, but you'll notice a remarkable improvement in the range and tone of your set. Only by selling direct can such value be offered. Half the price of foreign—a third the price of "ring" makes. You cannot get Letter or cheaper than this: 2-VOLT BATTERY TYPE, H.2, H.1.2, L.P.2, 1/9 each; Super Power P.2, 2/6 each; Screens and Pentodes, 3/9 each. A.C. MAINS, 4-VOLT, 1 AMP. General Purpose, 3/3; Power 4/- each; Screen and Pentodes, 4/6. FULL WAVE RECTIFIERS, 3/6 each. All post free. Every Valve actually tested before dispatch. Fully guaranteed. Cash with order or C.O.D. over 10/-. Data sheet of all types sent if desired. Send NOW. CLARION RADIO VALVE CO. (Dept. P.W.7), Tyburn Road, Edginton, Birmingham.



THIS BOOK will answer your Queries



THE HANDYMAN'S ENQUIRE WITHIN costs only a shilling, but it may save you pounds in time and material. In 96 lavishly illustrated pages it gives a representative selection of all those hints and tips which have been proved after years and years of use. All of them represent information in common demand arranged for immediate reference at the precise moment the information is required. Owners of the book also have the benefit of a correspondence service for handymen, if any particular specialised information is unavailable in the book. It is only one of the famous Newnes Home Mechanic Series. All are equally practical, equally inexpensive, equally handy and essential to the modern man who makes things.

Here are some others in the series

- THE HOME WOODWORKER
- MODEL BOAT BUILDING
- TOY MAKING FOR AMATEURS
- 25 SIMPLE WORKING MODELS
- MOTOR CAR OVERHAUL AND UPKEEP

- ACCUMULATORS—CAR AND WIRELESS
- MODEL AEROPLANES AND AIRSHIPS
- POWER-DRIVEN MODEL AIRCRAFT
- SIMPLE ELECTRICAL APPARATUS
- LATHE WORK FOR AMATEURS

Newnes' HOME MECHANIC BOOKS



Make Leisure hours
PLEASURE hours

Each 1/- net.

From all booksellers, bookstalls and newsagents—or 1/2 each post free, from George Newnes Limited, 8-11, Southampton St., Strand, London, W.C.2.

THE SEPTIMETRE

Operating and Further Notes on Our 7-Metre Receiver Designed Primarily for the Reception of the Television Sound Programmes

SOME constructors may hesitate to build the Septimetre owing to the fact that a metal chassis is used. If the chassis is obtained from the specified suppliers, Peto-Scott, Ltd., however, it will be ready-drilled and, therefore the constructional work will present no difficulties. Readers who have aluminium sheet of suitable gauge on hand can, of course, make their own chassis. A 1 in. drill should then be used for the valve-holder holes, and a $\frac{3}{8}$ in. size for the terminal strips. The size of the lead holes is not very important provided that sufficient clearance is allowed; a $\frac{1}{2}$ in. hole should prove quite satisfactory.

Mounting Components

It is advisable to mount the sub-chassis components before attaching the panel to the chassis. The wiring of these components should also be completed as far as is possible before the gang-condenser, V1 holder, and coil holders are mounted, in order to avoid damaging the latter when the chassis is turned over. The L.F. transformer is attached to the back runner and the H.F. choke is held in position by its own connecting wires.

The reaction condenser and on-off switch must not be mounted for the time being, of course, as their spindles

zontally in order that the leads may be kept as short as possible—this is very important in ultra-short-wave receivers. The support for V1 holder will be supplied with the metal chassis, and the screen separating the two coils and condensers will be attached to this support. For the benefit of those who intend making their own chassis it is pointed out that the valve-holder support and screen should

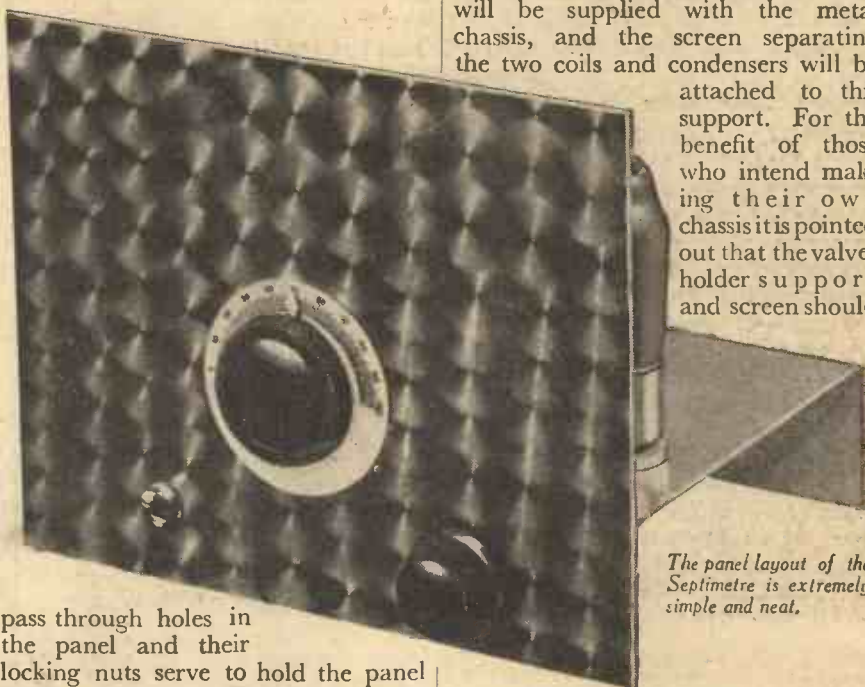

The panel layout of the Septimetre is extremely simple and neat.

pass through holes in the panel and their locking nuts serve to hold the panel to the chassis. The wiring of the L.F. transformer, V2, V3, R2, C4, and the terminal strips should therefore be completed and then the chassis can be turned over in preparation for mounting the surface components.

H.F. Screen

The S.G. valve is mounted hori-

be approximately 3 ins. high, the screen being part of the support. If desired, the screen can be made as a separate unit, bolted on to the valve-holder support, of course. It will be noted that a small screen is fitted between the two sections of the gang condenser by the manufacturers, and therefore it will be necessary to cut a piece out of the home-made screen so that the latter fits tightly over the condenser screen.

Coils

The coil-holders should be fastened to the chassis by means of small bolts and nuts. It will be advisable to leave a small clearance between the two holders so that the position of the two coils with respect to each can be varied. This provision for rotation of the coils on their axes will prove very useful, especially in the intervalve circuit. If reaction is too fierce the four-turn coil can be rotated so that it does not lie horizontal with respect to its associated 6-turn coil.

The panel can now be attached to the chassis and the reaction condenser, tuning condenser, and on-off switch placed in position. A bracket can be used to hold the tuning condenser to the chassis if desired, but this will not be found essential as the condenser spindle can be securely

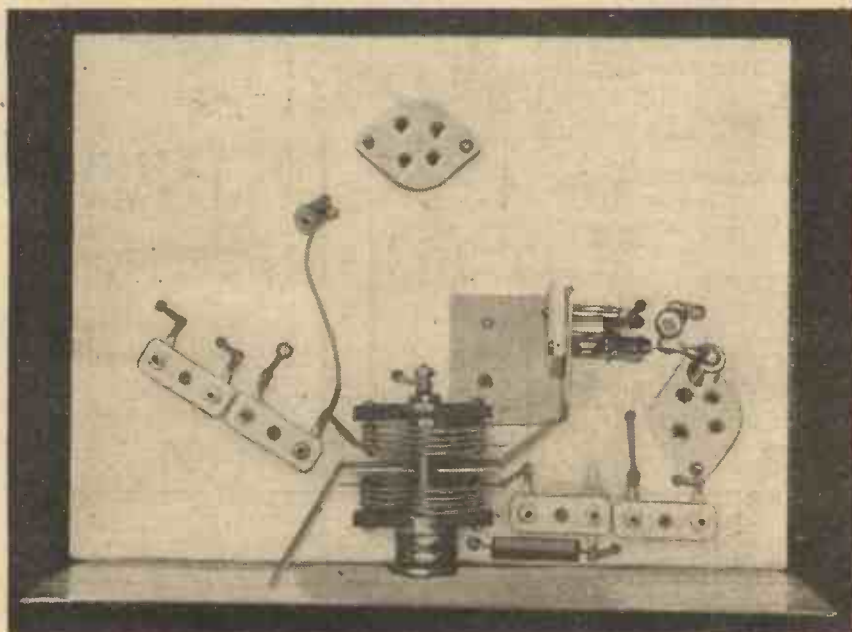

Here you see the compact and effective arrangement of the components on the chassis.

fastened to the panel by means of its locking nut. It will be noted that the on-off switch has four contacts at the top and four at the bottom. Only two of these contacts need be used in the Septimetre, however. It does not matter which way round the switch is mounted, provided that it is wired as shown in the wiring diagram.

Battery Components

After the wiring has been carefully checked, the battery, aerial-earth, and speaker or phone leads can be joined up. H.T.1 and H.T.2 leads should be connected to the 45- and 72-volt sockets of the H.T. battery approximately, and H.T.3 and H.T.— to the 120 and — sockets respectively. When the specified output valve is used G.B.— should be inserted in the $-7\frac{1}{2}$ socket of the G.B. battery and G.B.+ lead must of course be joined to the + socket of the same battery. Slight variation of the voltage on H.T.1 and H.T.2 may be found necessary in practice, and the best positions can best be found by experiment. L.T.— and L.T.+ leads must be connected to the two-volt accumulator in the usual manner, and the leads from the speaker or the phones should be plugged into the sockets provided on the L.S. terminal strip. When a dipole aerial is used its two ends should be joined to A1 and A2 sockets with no connection between A2 and E. If, on the other hand, an ordinary single wire aerial is used, A2 should be joined to E, with the aerial lead connected to A1.

Operation

When all the external leads are plugged in position the receiver may be switched on by means of the toggle switch on the left side of the panel. The tuning procedure is the same as for normal short-wave receivers. The specified tuning condenser has a slow-motion drive to facilitate tuning and a scale may be fitted if desired. This has not been specified, however, as many constructors will prefer to mark their own scale with the exact positions of the stations normally picked up. When listening to the sound programme from Alexandra Palace reaction will not be found necessary in many cases where the receiving aerial is in close proximity to the transmitter.

LIST OF COMPONENTS FOR THE SEPTIMETRE

- Two 6-turn, two 4-turn coils, No. 1,050 (Eddystone).
- Four bases, No. 1,051 (Eddystone).
- Two-gang condenser, No. 2,149, slow motion (C1, C2) (J.B.).
- Midget U.S.W. condenser .0001 (C3) (J.B.).
- Three fixed condensers: .1 (C4), .01 (C5) tubular, .0001 (C6), type M (T.C.C.).
- Two fixed resistances: 2 meg. (R1), 15,000 (R2) (Erie).
- One S.W. choke, 5-100 m. (Raymart).
- One L.F. transformer, Niclet 31-1 (Varley).
- Two terminal strips, A1, A2, E: L.S. (Clix).
- Three valveholders, 4-pin, S.W. type (Raymart).
- Three valves: SG220 S.W., D210 S.W., P215 (Hivac).
- Six plugs: H.T.1, H.T.2, H.T.3, G.B.+ , G.B.—, H.T.— (Belling Lee).
- Two Spades: L.T.+ , L.T.— (Belling Lee).
- On-off switch (B.T.S.).
- Metal chassis and panel, 10in. by 7 $\frac{1}{2}$ in. by 2 $\frac{1}{2}$ in. (Peto Scott).
- Speaker, type 37J (W.B.).
- 120-volt H.T. battery (Drydex).
- 9-volt G.B. battery (Drydex).
- 2-volt accumulator (Exide).

C.W. Reception

When it is desired to pick up continuous-wave morse transmissions, however, the detector valve must be made to oscillate by means of the reaction condenser. The voltage on H.T.2 must also be carefully adjusted if the receiver is to be used for C.W. morse reception, as excessive voltage at the anode of this valve will cause threshold howl. It will be noted that the anode of the first valve has to be connected to the centre turn of the second six-turn coil. This is done in order to reduce the damping effect on the detector tuned circuit. The same procedure may be adopted with the first tuned circuit, especially if an ordinary one-wire aerial is employed. In this circuit the tuning condenser C1 should be left connected to the end of the first six-turn coil, the cap of V1 being connected to the centre of the winding instead of to the grid end. Small crocodile clips can be used for this purpose provided that care is taken to keep the jaws clear of the adjacent turns. When the six-turn coils are used, tuning between approximately 6 and 8 metres should be effected, but the exact wavelength coverage will be governed to a certain extent by the stray capacity across the tuned circuits.

NEWNES' TELEVISION AND SHORT-WAVE HANDBOOK

3/6 or 3/10 by post from
 GEORGE NEWNES, Ltd., 8-11, Southampton St.,
 Strand, W.C.2.

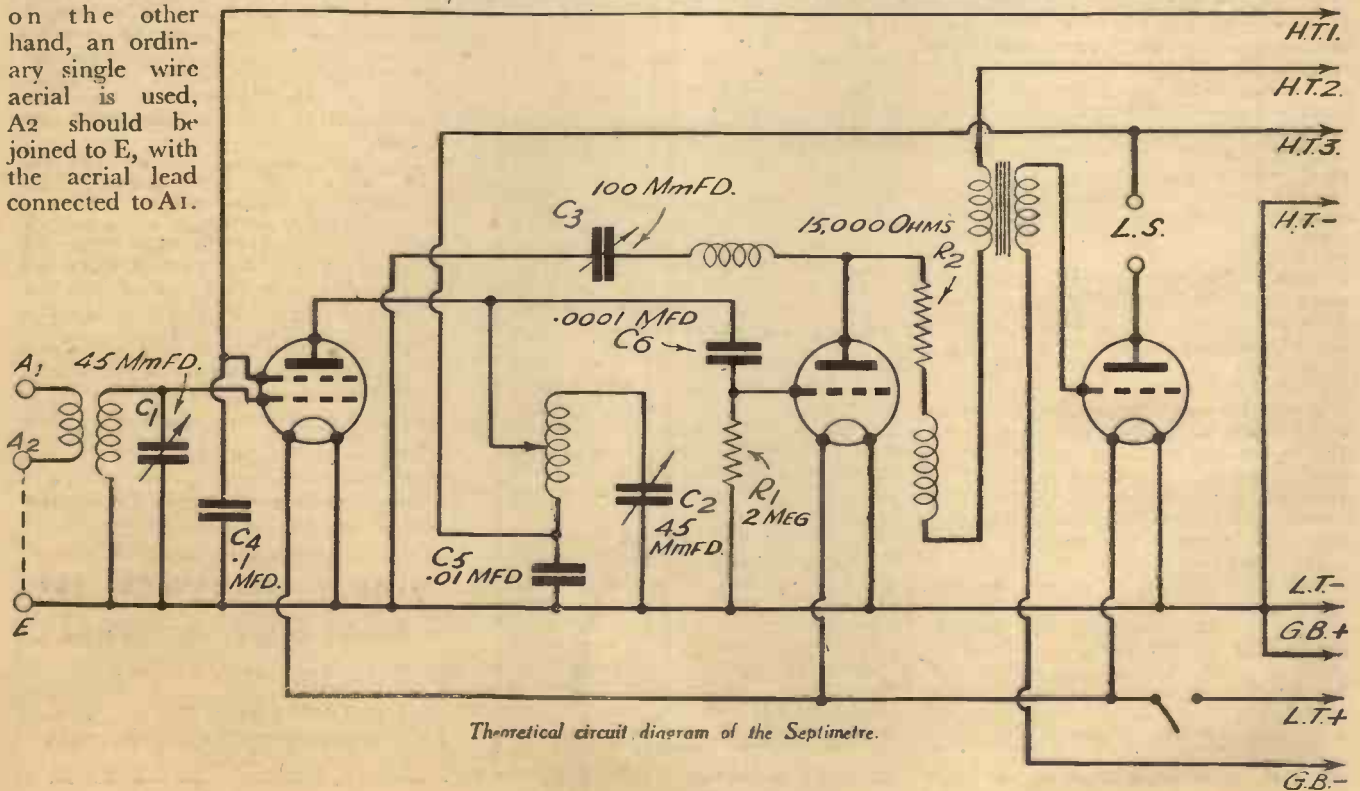

Theoretical circuit diagram of the Septimetre.

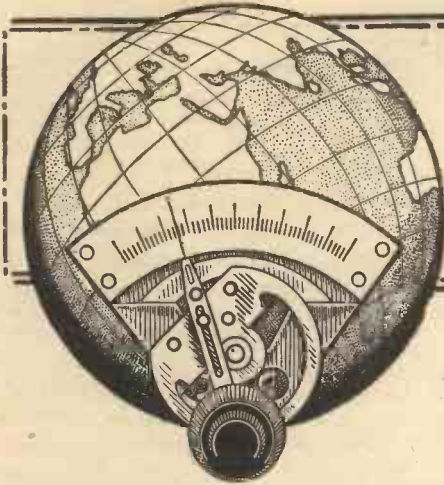

SHORT WAVE SECTION

VALVES AND THE U.S. WAVES

In this Article the Author Explains Why Valves are Inefficient on the Ultra-short-waves, and Discusses the Cause and Cure

By M. G. SCROGGIE, B.Sc., A.M.I.E.E.

EXPERIMENTERS who turn their attention from longer waves to ultra-short soon find that valves become less and less effective as the wavelength is reduced. What is not so well-known is why this is so. The explanations generally accepted as quite sufficient are these; the capacities between the valve electrodes cause increasingly serious loss; and the same is true of such insulating materials as are necessary in various parts of the circuit—to support coils, variable condensers, and so forth. To these may be added the argument that owing to the small number of turns of wire that can be used for tuning it is difficult to obtain strong magnetic coupling, or to build up high signal voltages. The valve capacity explanation is stressed by the remembrance that some years ago it was very difficult to obtain effective amplification even at ordinary broadcast wavelengths, until the problem was solved by the screen grid valve which reduced the grid-to-anode capacity to less than a thousandth of its former amount.

The "Acorn" Valve

All these explanations are correct so far as they go, but that is not far enough. Most ordinary valves require special care to make them work well below 30 metres; at 5 metres conditions become difficult—amplification is practically out of the question, and even oscillation has to be coaxied; and at about 3 metres nothing at all can be done. Yet there is a type of valve which is coming into use for ultra-short-wave work—the so-called "acorn" valve—which is perfectly happy at these wavelengths, and can be used even below 1 metre! The inter-electrode capacities in this type of valve are considerably reduced—about 1 $\mu\mu\text{F}$ instead of 4 to 8; but merely cutting out a few $\mu\mu\text{F}$ is not enough to account for all this difference in behaviour.

If they are added externally to an acorn valve it does not pack up completely, even although such added capacity may not be very "low-loss." Furthermore, tiny valves of other types, with capacities well below normal, are sometimes disappointing in their short-wave performance.

The concealed explanation is rather a curious one. We are so used to thinking of electricity as "instantaneous" that we are apt to forget that there are limits to its "agility." But when we require an electrical device to perform more than 60,000,000 complicated operations every second it is rather unreasonable to expect a hundred per cent. efficiency!

The electric current is conveyed across the empty space inside a valve by electrons.

These electrons, being so inconceivably small, are extremely light and fast-moving. A cloud of them is "boiled off" from the filament or heater of a valve; and, if a sufficient attraction is provided at the anode in the form of a positive voltage, they leap at it faster than any bullet. The length of the journey in an ordinary valve might be something like a fifth of an inch, and the time taken to cross is rather less than a four hundred millionth of a second. A single wave 300 metres long occupies about one millionth of a second, so the time taken by the electrons to cross the valve and convey the news to the anode circuit that a 300-metre wave signal has reached the grid is only about a four hundredth of the time occupied by the arrival of one wave.

Phase-Lag

This is a very slight delay or phase-lag, and need not worry anybody seriously. As you know, the effect of reaction in assisting amplification or in producing oscillation depends on the wave coupled back to the grid circuit being in step or

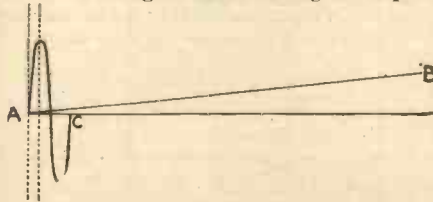

The slope AB represents quarter of a 300-metre wave. Owing to the time taken by a valve to act, the amplified version may be delayed to an extent represented by the horizontal distance between the dotted lines. This is not very significant in a 300-metre wave, but it has very important effects in a 3-metre wave, which is drawn between A and C.

phase with that which is there just at the moment. If the reaction coil is reversed, so that the fed-back wave is in opposition, the tendency is to damp out or destroy the signal instead of building it up. But, as has just been remarked, a difference in phase of a four hundredth of a wave is not serious.

That is at 300 metres. Now consider 3 metres. Instead of a four hundredth of a step it is quarter of a step, and thoughtful examination of a single wave form will show that whichever way a reaction coil might be connected it would be ineffective.

Although not a strict explanation of this phenomenon, the foregoing gives some insight into how it may upset the normal action of circuits. It is less clear how amplification is affected, as a rather advanced knowledge of electrical funda-

mentals is involved, but it may be taken as a fact that at very short wavelengths the effect of electron lag is equivalent to a resistance shunted across the grid-filament input. Very often we do actually connect a resistance there—a grid leak of a megohm or so—but it is important that it should not be too low or it would absorb in itself a large share of the valuable signal. At ultra-short wavelengths the equivalent resistance due to the valve dropping out of step is ordinarily only a few thousand ohms! This places an intolerable burden on any tuned input circuit, and amplification is practically nil, whatever pains may be taken to adopt every low-loss precaution.

A Remedy

The only remedy that has met with success is the construction of a type of valve specially designed to avoid lag. Reduction of the distance between electrodes is an obvious principle on which to work, though not the only one to be considered. The result is the acorn type of valve, produced originally in the R.C.A. laboratories in America, whence came the Iconoscope and other interesting developments. These valves can be obtained through Messrs. Claude Lyons, the well-known importers of American radio goods, the Osram Valve Works, who have been manufacturing them for some time, and Mullard.

The types that have so far appeared are a triode, and a H.F. pentode. They are indirectly heated valves, and it is interesting to know that in characteristics they can be compared on level terms with ordinary valves. Any sort of valve can be made to cause little loss of the type being considered, by applying an excessive grid bias and so reducing the mutual inductance; but, as the gain is reduced, too, the net result is no better and is actually rather worse. Acorns have mutual conductances that are measured in milliamps per volt, and besides their use at wavelengths at which other valves go out of business, they can be used for other purposes where small valves are required with no sacrifice in performance.

NEWNES' TELEVISION AND SHORT-WAVE HANDBOOK

3/6 or 3/10 by post from

GEORGE NEWNES, Ltd.,
8-11, Southampton Street, Strand, London,
W.C.2.

Let Us Send You This 40-Page Booklet—Free



It gives full information regarding various I.C.S. Courses of Instruction in Radio work.

The Radio industry is progressing with amazing rapidity. Only by knowing thoroughly the basic principles can pace be kept with it. I.C.S. Instruction includes American broadcasting as well as British wireless practice. It is a modern education, covering every department of the industry.

OUR COURSES

Included in the I.C.S. range are Courses dealing with the installing of radio sets and, in particular, with their Servicing, which to-day intimately concerns every wireless dealer and his employees. The Equipment Course gives sound instruction in radio principles and practice.

There is also a Course for the Wireless Salesman. This, in addition to inculcating the art of salesmanship, provides that knowledge which enables the salesman to hold his own with the most technical of his customers.

Then there are the Preparatory Courses for the City and Guilds and I.W.T. Exams.

We will be pleased to send you details and free advice on any or all of these subjects. Just fill in, and post the coupon, or write in any other way.

International Correspondence Schools, Ltd.,
Dept. 94, International Buildings,
Kingsway, London, W.C.2.

Without cost, or obligation, please send me your "Radio" booklet of information about the Courses I have marked X

- COMPLETE RADIO
- RADIO SERVICING
- RADIO EQUIPMENT
- RADIO SERVICING AND SALESMANSHIP
- WIRELESS ENGINEERING
- EXAMINATION (state which)

Name Age

Address

Leaves from a Short-wave Log

CONDITIONS during the past fortnight or so have been most promising as they have shown considerable improvement over the preceding period; it has been possible, on most evenings, to listen to DX broadcasts. Of the amateur bands the 20-metre section has proved the most favourable, inasmuch as on and around the 40-metre "amateur preserves" the invasion of pseudo-amateurs has daily become increasingly unpleasant. If an hour or so from B.S.T. 22.00 is devoted to a search around 19-25 m. the listener should succeed in making a number of loggings not only from the official broadcasters in Europe and America, but also from U.S.A. and Canadian amateur transmitters, including some in Nova Scotia and Newfoundland. Many of the conversations which take place between these experimenters in different American states or between the U.S.A. fans and their British colleagues are very interesting and, at times, distinctly amusing.

New Columbia Radio Playhouse

To secure the right atmosphere the U.S.A. organisations for the production of their radio plays are not content to use ordinary studios, but are now adapting existing theatres to their special requirements. Listeners to W2XE, Wayne (N.J.), taking the WABC, New York, key station programme of the Columbia Broadcasting system will shortly notice a great improvement in the matter of acoustics, as this organisation has now taken over for broadcast plays the Manhattan Theatre (late Hammerstein) in Broadway. According to statements made by their own engineers the stage "literally floats on a cushion of noise-destroying material"; it is to be the most modern radio theatre in the world.

A Special Broadcast from Canada

CFCX, Drummondville (Quebec), which relays the CFCF, Montreal, Canadian Radio Commission programme daily, will be carrying out a special transmission on September 20th next between B.S.T. 08.00-09.00. The wavelength is 49.96 m. (6,005 kc/s), and the power 750 watts.

Ecuador on the Ether

On 38.20 m. (7,854 kc/s) you should try for HC2JSB, Guayaquil, which is now regularly working with a power of 500 watts between B.S.T. 00.20-05.20 daily, excepting Mondays. Although most announcements are made in Spanish, the call in English is *Ecuador Radio, the Voice of the Andes*, and two chiming notes are struck previous to any speech or musical item. Veri's are obtainable from Sr. Juan S. Behr, Radiodifusora HC2JSB, Guayaquil (Ecuador).

Another broadcast for which a search should be instituted between those hours, but only on Mondays and Fridays, is from HCK, Quito, on 50.98 m. (5,885 kc/s), 250 watts, and which styles itself *Radiodifusora del Estado*. Address: *Direccion General de Telegrafos, Telefonos y Malambros Quito (Ecuador)*. The reception of this station has been recently reported on several occasions by listeners in France.

Moscow Time-Table

Again an alteration is to be registered in the schedule of the Moscow broadcasts. Four channels are now in regular use and the time-table is as follows: On Sundays,

25 m. (12,000 kc/s), at 11.00 G.M.T.; at 15.00 on both 25 m. and 19.88 m. (15,083 kc/s); at 18.30 on 19.76 m. (15,180 kc/s), and again on 25 m. at 21.00 G.M.T. The 25-metre wave is used for broadcasts on Monday, Wednesday and Friday at G.M.T. 21.00. In addition, there is a daily transmission between G.M.T. 00.00 and 02.00 on 31.51 m. (9,520 kc/s) in Spanish, English and German.

A New Venezuelan

French listeners report the reception between G.M.T. 23.00 and 03.30 of a transmitter styling itself: *Ecos del Orinoco* and giving its location as Ciudad Bolivar. The call-letters are YV11RB and the station works on 45.84 m. (16,545 kc/s). It is situated at Bolivar City, Venezuela.

Listen to Iceland

With the exception of the north of the British Isles the reception of Reykjavik broadcasts on the long waves is not an easy matter. It is possible, however, on Sundays to hear the short-wave transmitter TFJ, on 24.52 m. (12,235 kc/s), between G.M.T. 18.30-19.00, when an English talk is given; from 19.00-21.30 the transmission switches over to German and Danish. A woman announcer presides in the studio and regularly calls: *Rikisutvarp Island*. The broadcasts open with a tuning-note and usually close down with a choral rendering of an Icelandic anthem.

Prague Short-wave Transmitter Starts Up

OLR, Podedbrady-Prague, on 19,689 m. (15,230 kc/s) and 31.57 m. (9,504 kc/s), is now on the air daily. On the lower channel a relay is carried out of the Prague main programme between G.M.T. 19.25-21.20, including a special news bulletin in English at G.M.T. 21.15. Every Tuesday and Friday a broadcast is made for listeners in the United States between G.M.T. 02.00-04.00 with an S.B. on 31.57 m. (9,504 kc/s). Earlier on weekday evenings the transmitter may be heard carrying out tests on its various channels.

Lisbon's New Short-waver

Tests may be heard almost nightly of the new Portuguese short-wave station CSW which is destined to relay the Lisbon programmes for consumption overseas. The wavelength announced is 31.41 m. (9,550 kc/s), and the time at which transmissions have been heard is between G.M.T. 22.15 and 23.00. Reports of reception should be sent to National Broadcasting Station CSW, Lisbon, Portugal.

An Old Costa Rican Friend

TI4NRH of Heredia (Costa Rica), on 31.02 m. (9,670 kc/s) although only boasting of 100 watts may now be found again towards the early morning hours. Try between G.M.T. 04.00-05.00 when you should pick up his slogan: *La Voz de Comercio*. At 03.00 and at 05.00 the station usually closes down with the sounding of a long bugle call. Announcements are made alternately in Spanish and English, but the call-letters are not frequently given.



IMPRESSIONS ON THE WAX

By
T. Onearm

Tino Rossi's Second Record

TINO ROSSI, the French star, makes his second record in the September Columbia list. His repertoire consists of the fascinating Corsican tunes that so characterise that island. In his new record there is one called "O Corse ile d'Amour" (Corsica, Isle of Love) which is a fine example, and it has as companion "Marinella," a song from the film of that name, in which Rossi made his big hit. The number of the record is *Columbia DB 1468*.

The Waltz from Act II of Gounod's opera "Faust" fascinated Franz Liszt, who eventually arranged an admirable transcription for the pianoforte. Liszt's version is very difficult and rarely appears in concert programmes. Egon Petri, the famous pianist, has recorded this pianoforte solo on *Columbia LX 520*.

New Irish Records

OF special interest is the list of new Irish records just issued by Columbia. A newcomer to the lists—although a well-known artist with his native folk—is John Fee, who sings "The Irish Emigrant" and "Farewell My Gentle Harp," on *Columbia FB 1445*, and "Believe Me, if All Those Endearing Young Charms," coupled with "The Snowy-breasted Pearl," on *Columbia FB 1446*. Sam Carson, an old favourite, is also featured in a group of fine sacred songs. Terence O'Brien, the Irish tenor, rounds off the list with "Bless this House" and "Just for To-day" on *Columbia FB 1452*.

"Theatre Memories"

ANYONE who wants a variety bill of his own choice has all the material to hand in the current Columbia lists. He can lead off with the second of the new "Theatre Memories" series by Debroy Somers' Band—the hits from all the most famous of Daly's productions—on *Columbia DX 748*.

He can follow with Arthur Marshall, the popular broadcasting humorist, who gives laughable impressions of schoolgirls. His new contributions are "Showing the School" and "The Games Mistress," on *Columbia DB 1652*.

Louis Levy and his very popular Gaumont British Symphony would probably come next with a selection of theme songs from "The Great Ziegfeld"—*Columbia FB 1477*—after which Les Allen (accompanied by Sidney Torch on the organ), singing "Dear Little Boy of Mine" (predicted to be another "Little Man, you've had a Busy Day"), with his Canadian Bachelors on the reverse side in "I'll Stand By," on *Columbia FB 1474*.

Another Spot of Bother

ANOTHER amusing spot of bother comes from Clapham and Dwyer this month. This time they are "Buying a House," on *Columbia FB 1444*. Albert Sandler and His Orchestra are also to be heard this month on *Columbia*

FB 1443. They play the famous Russian air "Black Eyes," coupled with "Souvenir d'Ukraine." Carroll Gibbons and his Boys are to be heard on *Columbia FB 1471*, playing "Sugar Rose" and "Breakin' in a Pair of Shoes."

A "Storm Fantasia"

AN unusual record this month is "Storm Fantasia" played by Quentin Maclean on the giant organ of the Trocadero Cinema—*Columbia FB 1441*. A couple of saxophone solos, for those who like them, are recorded by Howard Jacob on *Columbia FB 1442*. They are that old favourite "I Love the Moon" and "From the Land of the Sky-blue Water."

Sidney Torch has made a fine medley record this month, on the Edmonton Regal Cinema Organ, in "Torchlight Music." He opens with "I Want to Sing a Torch Song" (most appropriate), and from "El Relicario" passes through "I Love the Moon," "Buffoon," "Schom Rosmarin" and "Dicky Bird Hop," finishing with "Until"—a thoroughly mixed bag! He is assisted by Webster Booth (tenor) and Alfredo Campoli (violin). The number of the record is *Columbia DX 747*.

Two Popular Artists

TURNER LAYTON has contributed three new records this month in which he features half a dozen popular songs. He sings "I Wanna Woo" coupled with "You" (from "The Great Ziegfeld") on *Columbia FB 1475*, "A Rendezvous with a Dream," and "Alone Again," *Columbia FB 1470*, and finishes with "A Marriage has been Arranged," bracketed with "Lancashire Lass" on *Columbia FB 1476*.

Renee Houston also records four tunes from her latest film "Happy Days are Here Again," on *Columbia FB 1467*.

Brunswick

THE latest Bing Crosby film "Rhythm on the Range" is featured in the Brunswick list for this month with the artist himself singing the two principal numbers from the film "Empty Saddles," and "I'm an Old Cowhand," on *Brunswick O 2270*. This Company also present this month, the first record of Judy Garland, a twelve year old rhythmic singer, on *Brunswick O 2267*. The tunes are "Stompin' at the Savoy" and "Swing Mister Charlie." Other recordings are "Estrellita" and "La Villanelle," sung by Erna Sack on *Brunswick O 2250*, Leo Reisman and his Orchestra playing "Stars in my Eyes," coupled with "On the Beach at Bali-Bali," *Brunswick O 2253*, and a pianoforte solo by Lee Sims on *Brunswick O 2266*, on which he features "These Foolish Things," and "Take my Heart."

Decca-Polydor

THIS Company present a new recording of Beethoven's Emperor Piano Concerto with Kempff as soloist in association with The Berlin Philharmonic Orchestra. The set of records comprising this Concerto, five in number, are *Decca-Polydor CA 8248/52*.

EASY TERMS

NEW 1936-1937 RADIO

FOR MORE THAN TEN YEARS we have SPECIALISED in the supply of all good quality RADIO SETS, COMPONENTS, VALVES AND ACCESSORIES. SEND LIST OF YOUR REQUIREMENTS and we will supply keen quotation by return.

W.B. STENTORIAN SPEAKERS



These splendid Speakers are available on Easy Terms:—

37j Cash price 32/6, or 2/6 with order and 11 monthly payments of 3/-.

CABINET and EXTENSION SPEAKERS on similar terms. FULL LIST ON REQUEST

Wharfedale Goodman's Rola Loudspeaker Units
Supplied on the best terms—Complete list sent free.

★ MCCARTHY CHASSIS ★

The remarkable New Model 8F6AW ALL-WAVE CHASSIS—Cash price £8/10/-, or delivered for First Payment £1/7/-, and 10 monthly payments of 16/-.

LATEST PICK-UPS, GRAMO-MOTORS & VALVES

All the newest products of well-known Makers supplied on the best of Easy Terms. WRITE FOR NEW VALVE LIST.

ELIMINATORS

All well-known makes supplied for FIRST PAYMENT of 5/-.

WE GUARANTEE SATISFACTION TO EVERY CUSTOMER. PROMPT DELIVERY. CASH or C.O.D. ORDERS SENT BY RETURN.

Estd. 1925 THE LONDON RADIO SUPPLY COMPANY PHONE NATIONAL 1977

LONDON RADIO SUPPLY COMPANY

11 OAT LANE, NOBLE STREET, LONDON, E.C.2

EASY PAYMENTS

"THERE'S NO PLACE LIKE HOLMES." Monthly

	Deposit	Payments
W.B. 37 J	32/6	4/5 7 of 4/5
ROLA F1020 P.M.	38/6	4/- 9 of 4/3
CELESTION SENIOR 9	55/-	5/- 11 of 5/-
MAGNAVOX THIRTY-THREETS/-		6/10 11 of 6/10

Any make of speaker supplied.

GRAHAM-FARISH SEN- CITY SUPER 50/- 4/7 11 of 4/7

GRAHAM-FARISH ALL WAVE KITS 57/6 5/3 11 of 5/3

SPECIAL—G.E.C. universal mains A.C. or D.C. with M.C. Speaker, complete with valves in cabinet. List price, £6 10s.

Our Price 7s. deposit and 11 payments of 7s. 8d.

PARTS FOR ANY SET. ANY MAKE OF SPEAKER.

New goods obtained for every order.

Send us a list of parts or valves you require or any speaker or set you may select and we will forward you a definite quotation. Ten years' advertiser in the Wireless Press.

Thousands of satisfied customers.

H. W. HOLMES, New Address:—333, EUSTON ROAD, LONDON, N.W.1.

Phone: Museum 1414.

MORSE CODE

PRACTISE AT HOME WITH THE ELECTRADIX SET

Contact, Buzzer and Battery, on Walnut Base, Ready for use. **4/9**

Heavy practice Buzz Sets, 10/- POST FREE

SPECIAL PATROL Car Key 18/6.

TAPPING KEYS 4/6, 7/6, 12/6, 18/6, 21/-

SECRET RAY Kits with selenium cell, 45/-

SPEEDOMETER Timing Equipments from £25.0.0

MICROPHONES for detection and listening. See Meter List "N.R." free. HEADPHONES 2/9 pair

1,000 OTHER BARGAINS in our Ex.-Govt. and General Sale List "N" free. Send addressed envelope to

ELECTRADIX RADIOS, 218, UPPER THAMES ST., LONDON, E.C.4.

Telephone: Central 4611.



LETTERS FROM READERS

The Editor does not necessarily agree with opinions expressed by his correspondents.



All letters must be accompanied by the name and address of the sender (not necessarily for publication.)

Up, the Home Constructor!

SIR,—May I add my name to those of your readers who have written recently suggesting the forming of a PRACTICAL AND AMATEUR WIRELESS League or Club?

With the majority of your regular readers in support, such a club could, I am sure, hold a strong position in wireless affairs to the general benefit of all concerned. One has only to reflect on the power wielded by your excellent journal to realise this point.—JOHN F. BARLOW (Exeter).

QSL from SUICH

SIR,—I read that W. E. G. Barlett (Weymouth) has never heard of anyone possessing a QSL card from SUICH. Well, I sent him a report on August 7th, 1936, and within two weeks his QSL card arrived, which I was very surprised to receive so promptly. He mentions that his transmitter is as follows: 47-830-203A, 150 watts; Ant: Zep. So to those who have not yet received his QSL card I say try again.—E. A. J. ROGERS (Romsey).

QSL Cards: Home Constructors

SIR,—I have read with interest the letters of W. T. C. (Walthamstow), G. M. (West Ealing), and others, and note their remarks with regard to QSL cards. I agree with W. E. G. B. (Weymouth) that a great number of reports sent in are of no material use whatever, and only cause the recipient so much annoyance that he ceases to issue cards, and after all one can hardly blame him.

I have seen quite a number of requests for new S.W. circuits lately. Why don't readers try designing their own for a change? In the old days one had to wind coils and construct quite a number of components on the bench. Is interest in this field dying out? If they know the fundamental basis of S.W. circuit design they would not find it very difficult, and would experience a feeling of achievement on completion of a satisfactory design. A standard kit of parts can be tried out in several forms before deciding on a final circuit. This would improve their knowledge and afford a pleasurable pastime. They could also try winding their own coils.—M. L. HUNT (Knutsford).

Back Numbers Wanted

SIR,—I find that *Amateur Wireless*, No. 547, dated December 3rd, 1932, is out of print, and shall be greatly obliged if any reader would sell or loan me a copy. I will gladly pay the necessary postage.—A. COLBY (Police Station, Batley, Yorks).

Correspondent Wanted

SIR,—I am a member of the B.L.D.L.C., and will be glad to get in touch with another enthusiast in my district.—P. H. SALMON ("Lydbrook," Hampstead Lane, Highgate, N.6).

Reports and Postage

SIR,—I have read with considerable interest the correspondence on the subject of QSL cards, and agree that the

ignoring of a reply coupon requires some explanation, but before Mr. Owen suggests meanness he should seek further information.

I am personally acquainted with Mr. Cooper (Walthamstow), and have seen the thirty-seven cards he mentions, and not one had a reply coupon. One peculiar point about all these cards was that they all reported on transmissions from Mr. Cooper's station, and asked for QSL cards before he had a radiating licence or even a transmitter.

One of these cards from an American let the cat out of the bag. His card reported reception of the non-existent transmissions with a note that he had obtained Mr. Cooper's address from an Australian who had had a card and wished to "swap" cards. Suppose one is sent, Mr. Cooper will be pestered by someone else, possibly in another part of the world, and so it will go on.

At the same time a letter was received from a native of Kumassi, asking for a QSL card, a photo, and a wrist watch, and promising in return, amongst other things, monkey skins.

The whole business has now become a form of chain letter, which is to be expected when it is stated in the Press that collections of these cards will in the future assume a monetary value.

I disagree most emphatically that it is part of a transmitter's work, and if Mr. Owen imagines that all these amateurs are wealthy men let me disillusion him. They are not, and, after all, QSL cards do cost money. So why should the transmitting amateur waste them, and his time and money, acknowledging reports, the majority of which are of no value whatever (they are always R7-9, T9, QSA5, vy. ft. OM pse qsl), and supply the material for a hobby which is rapidly reaching the same level as collecting cigarette pictures.—J. W. ISMAY (G6JI) (Walthamstow).

Our Remarkable Prefect 3

SIR,—Thanks to PRACTICAL AND AMATEUR WIRELESS I have at last a wonderfully efficient four-valver. I built the Prefect 3, together with its H.F. unit, on a single chassis, with a screen on top and underneath with half-inch space between the two screens. For the H.F. screen I have a 50,000 ohm potentiometer panel mounted. The anode connection is taken round the back of both screens. I use a seven-pin Osram VP21, Osram detector, a Hivac detector in the first L.F., and a Mullard power valve. For the antenna I have a single strand 12 gauge half-wave 30 metre, about 20ft. top and 40ft. vertical. Up to the present I have received over 200 stations in one month of week-end listening, including three Japs JVH, N and M, Bombay VUB, three Cubans, eleven Australian amateurs, forty-seven American amateurs, and a variety of South Americans, Mexicans, and Colombians. Most of these stations have been on 'phones, but all B.C. stations are received on a Stentorian M.C. speaker at average RS.—VICTOR M. RIX (London, S.W.).

REPLIES IN BRIEF

The following replies to queries are given in abbreviated form either because of non-compliance with our rules, or because the point raised is not of general interest.

S. H. (Coventry). It is probable that the lack of reaction and low sensitivity is due to the use of unsuitable or inefficient valves. If the valves are in order we advise you to have the coil unit tested by the manufacturers.

T. K. (Glasgow). We do not know of any ultra-short-wave amateur transmitters in your locality. We suggest, however, that you communicate with the Radio Society of Gt. Britain, 63, Victoria Street, London, S.W.1, concerning this.

F. S. A. (Twickenham). We suggest that you build the Midget Short-wave Two described in the issue of PRACTICAL AND AMATEUR WIRELESS dated September 15th, 1934 (Blueprint No. PW38A), or the Bandspread Three, described in the issues dated August 29th and September 5th, 1936.

A. G. C. (Reading). We have not tried your valve types in the Monitor but it is probable that they will give satisfactory results. The VP2 would be more suitable than the SP2, however. The suppressor grid and metallising should be connected to earth, the sixth pin being unused.

W. H. (Bradford). Coil types A, C, and D may be used in the Bandspread Three without altering the existing wiring in any way.

A. H. O. (Hitchin). An article giving constructional details of a unit for supplying H.T. from a 6-volt accumulator will be found on page 740 of PRACTICAL WIRELESS dated December 23rd, 1933. This subject will be dealt with again in the near future, and circuit arrangements for the Bulgin H.T. unit may be obtained from Bulgin, Ltd., Abbey Road, Barking, Essex.

J. P. (S.W.17). We understand that E. K. Cole, Ltd., are manufacturing Ekco receivers in Belgium, the Belgian company being known as Ekco Belge. Perhaps it would be advisable for you to obtain one of their receivers.

R. F. H. (Alton). The quality of reproduction from the expensive speakers referred to in your letter was, of course, better than that obtainable from the small speakers incorporated in the table model receivers. This is mainly due to the fact that the quality speakers have a more powerful magnet and a wider frequency response than the smaller types used in cheap receivers, and not to the fact that the small speakers are specially designed for the receiver circuit arrangements.

E. W. H. (Staines). The receiver you refer to should prove satisfactory if the Eddystone coils and .00016 mfd. condensers are used.

W. C. T. (Breckley). The consumption of the battery Hall-Mark Four when using the specified triode valves is approximately 17 mA. The Milnes unit should prove quite satisfactory. The fact that the wave-change switch control operates in the reverse direction to that mentioned in the article does not indicate that it is defective or of the wrong type.

J. S. (Sale). The design of a three-valve all-mains receiver has not been published this season, but it is probable that a circuit which will meet with your requirements will appear within the next few weeks.

C. P. (Barrow-in-Furness). We think that the best procedure will be for you to construct one of our standard designs as a wiring diagram of the circuit you refer to is not available. The Hall-Mark Four or the Limit All-wave Four should meet with your requirements.

J. A. G. (Alloa). We understand that the makers of your receiver are no longer in business. The selectivity could be improved by using modern iron-core coils—e.g. Varley types B.P.50 and B.P.51.

J. B. C. (Glasgow). If your gang condenser is of the 405 Kc type the moving vanes of one section will be much smaller than those of the other two sections. In the 110 Kc type the moving vanes of all sections are usually the same size, but the fixed vanes of the oscillator section are slightly smaller than those of the other sections.

R. S. (Hayes). We suggest that you build the Centaur Three described in the issue of PRACTICAL AND AMATEUR WIRELESS dated December 7th, 1935. A pentode may be used in this receiver if a five-pin valve-holder is fitted in the output stage with the centre pin connected to the 120-volt socket of the H.T. battery.

D. G. (Kingston-on-Thames). Your proposed method of mounting the speaker will be in order, but the back of the speaker must not be covered over. It will not be necessary to screen the leads.

F. E. B. (Cardigan). A receiver design of the required type has not been published in PRACTICAL AND AMATEUR WIRELESS, but we understand that A. F. Bulgin, Ltd., Abbey Road, Barking, Essex, market a suitable kit.

G. S. (Woodlands). It is probable that a suitable receiver may be obtained from Electradix Radios, Upper Thames Street, London, E.C.4.



Facts and Figures

COMPONENTS TESTED IN OUR NEW LABORATORY

Dubilier Accessories

THE accompanying illustration shows two interesting Dubilier products which have been introduced this season. The upper is a new wire-end condenser available in most of the smaller capacities and designed for inclusion in the wiring of a receiver to avoid bulk. The wire ends are firmly embedded and may, of course, be cut to any desired length. The other component illustrated is the Fadover control used for switching from pick-up to microphone, from pick-up to radio, or for any other desired two-way arrangement where a gradual fade-out of one form of reproduction is required to be followed by

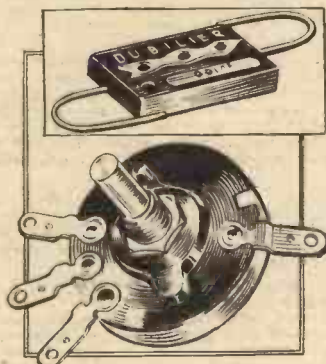

Two new items from the Dubilier range—a fixed condenser and the Fadover control.

a gradual introduction of any other item. The device consists in effect of two volume controls in series, with one control arm, and the junction of the two sections is indicated by the contact strip seen on the right of the component, and also by a small recess inside the unit. Thus, as the arm is rotated the centre position may be felt, and at this point volume is reduced to zero and the control may be left in that position as an "off" setting. Each section of the element is designed to follow a logarithmic law, and the price of this useful device is 6s. 6d.

Easily-made Charges

IT is not as widely known as it should be that F. C. Heyberd and Co.—well known as makers of high-grade mains transformers—supply a number of constructional kits for battery chargers. There are four principal kits, each of which comprises all the parts needed for making an A.C. charger in half an hour. The smallest (Set W.L.T. 2) gives an output of 2, 4, or 6 volts at ½ amp.; the next (Set W.L.T. 4), 2, 4, or 6 volts at 1 amp.; the third (Set W.L.T. 5), 6, 10, or 12 volts, at 1 amp.; and the largest (Set W.L.T. 6), 2, 4, or 6 volts at 2 amp. Prices for these are 30s. 6d., 32s. 6d., 41s., and 54s. 6d., respectively, postage in each case being 1s. extra.

The kits of parts include a standard Heyberd shrouded transformer, the appropriate Westinghouse metal rectifier and an output regulating resistance, along with a wiring diagram. Ease of construction is proved by the fact that only seven wires and ten connections are necessary. The assembled charger is equally as efficient as any ready-made one on the market.

W.B. Stentorian Junior

WE are asked to point out that, owing to a clerical error, the price of the W.B. 1937 Stentorian Junior chassis model has been advertised at 37s. 6d. The correct price of this chassis is 32s. 6d.

New Jackson Gang Condenser

A NEW gang condenser introduced by Jackson Bros., is of the bar type, and is specially designed to give a low minimum capacity. It is particularly suitable where low losses are essential, such as in all-wave receivers. As will be seen in the accompanying illustration the condenser is of exceptionally robust and rigid construction. The minimum capacity is 17 mmfd. and the maximum capacity 510 mmfd. The trimmers provide an additional 50 mmfd. The prices for this condenser are 2-gang, 12s. : and 3-gang, 17s. 6d.

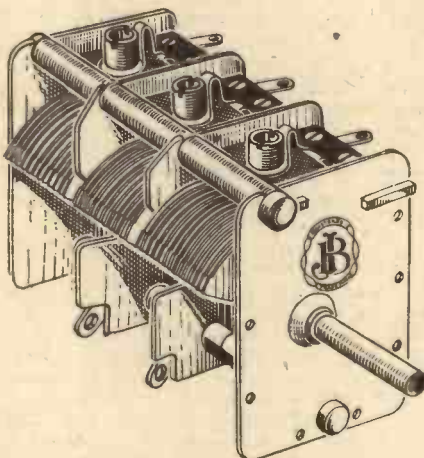

The new J.B. Bar-type gang condenser.

B.T.H. Headphones

FOR use with deaf-aid apparatus, short-wave receivers, and other apparatus in which headphone reception is required,

TUNGSRAM CHANGE OF ADDRESS

OWING to increased business activity, the Tungoram Electric Lamp Works are moving, as from September 28th, 1936, from the 72, Oxford Street address. The new address of this company will be Tungoram House, 82-84, Theobald's Road, W.C.1, and the new 'phone number will be Holborn 3563-4-5. Any communications regarding valve replacements should be addressed to Department "RV," British Tungoram Radio Works, Ltd., West Road, Tottenham, as only small stocks of valves will be held at Tungoram House. The departments which will be housed at Tungoram House, are, Managing Director, Secretary, Sales and Sales Promotion, Order and Stock, Accounts, Technical and Publicity.

a light-weight headset is of great value. Messrs. Edison Swan Electric Co. are introducing a new light-weight model B.T.H. headphone having adjustable moulded earpieces, a chromium-plated headband and wound to a total resistance of 4,000 ohms. The total weight of the headset is only 8ozs. and a 5ft. length of cord is supplied with pin ends. The price is 12s. 6d.

A Gas Blowpipe

FOR soldering and other similar processes, the new gas blowpipe introduced by A. J. Wright, of 10, Mitchell Street, E.C.1, will be found a valuable tool for the constructor and service engineer. This is of the double type with angled mixing head, the air and gas pipes being mounted in the usual manner, and the air pipe provided with a rubber tube and mouthpiece. The price of this accessory is only 3s., and it is claimed that it will melt an ounce of aluminium in five minutes. Thus the heat generated is sufficient to enable the tool to be used for light brazing work, and it should therefore be found in every constructor's workshop.

Philips All-wave Aerial Kit

AN all-wave aerial kit has been produced by Philips Lamps Ltd. The price is 25s., and the usual form of T aerial and matched di-pole is adopted. The kit is complete with insulators and special matching transformer.

Pye "Match-All" Speaker Link

TO obtain maximum results, both from the point of volume and of quality, it is essential that a speaker or headphones should be matched to the output-valve. This is generally accomplished in the receiver proper, but when an extension listening point is employed the additional speaker or 'phones may result in the balance being upset, unless some form of accurate matching is employed. A useful device in this connection is the Pye unit illustrated below. This is a neat cylindrical device provided with a flange so that it may be screwed to the side or back of a cabinet, and input and output terminals are provided. By a suitable combination of terminals it is possible to match any output load from 1 to 6,000 ohms and above, and a table showing the correct terminals



For accurate output matching, this new Pye "Match-all" Unit is very useful.

is supplied with the device. In addition the instruction leaflet gives details showing where a "match-all" extension speaker link should be used, and complete details are provided for installing the link. It is important to note that D.C. voltages must be isolated from the device, and where it becomes necessary to connect it in an output circuit where D.C. is present, a 1 mfd. condenser should be joined in series with it. The price is 10s. 6d.

Practical and Amateur Wireless BLUEPRINT SERVICE

RADIO CLUBS AND SOCIETIES

Club Reports should not exceed 200 words in length and should be received First Post each Monday morning for publication in the following week's issue.

PRACTICAL WIRELESS STRAIGHT SETS. Battery Operated.		
One-valve : Blueprints, 1s. each.	Date of Issue.	No. of Blueprint
All-Wave Unipen (pentode) ..		PW31A
Two-valve : Blueprints, 1s. each.		
Four-range Super Mag Two (D, Pen) ..	11.8.34	PW36B
Three-valve : Blueprints, 1s. each.		
Selectone Battery Three (D, 2 LF (trans.)) ..		PW10
Sixty-Shilling Three (D, 2 LF (R.C. & trans.)) ..	2.12.33	PW34A
Leader Three (SG, D, Power) ..		PW35
Summit Three (H.F. Pen, D, Pen) ..	8.8.34	PW37
All-Pentode Three (HF Pen, D (pen.), Pen) ..	22.9.34	PW39
Hall-Mark Three (SG, D, Pow.) ..		PW41
Hall-Mark Cadet (D, LF Pen (R.C.)) ..	10.3.35	PW48
F. J. Camm's Silver Souvenir (HF Pen, D (pen), Pen) (All-Wave Three) ..	13.4.35	PW40
Genet Midget (D, 2 LF (trans.)) ..	June '35	PM2
Cameo Midget Three (D, 2 LF (trans.)) ..	8.0.35	FW51
1936 Sonotone Three-Four (HF Pen, HF Pen, Westector, Pen) ..	17.8.35	PW53
Battery All-Wave Three (D, 2 LF (R.C.)) ..	31.8.35	PW55
The Monitor (HF Pen, D, Pen) ..	8.2.36	PW61
The Tutor Three (HF Pen, D, Pen) ..	21.3.36	PW62
The Centaur Three (SG, D, P) ..		PW64
The Gladiator All-Wave Three ..	29.8.36	PW66
Four-valve : Blueprints, 1s. each.		
Fury Four (2 SG, D, Pen) ..		PW11
Beta Universal Four (SG, D, LF, Cl. B) ..	15.4.33	PW17
Nucleon Class B Four (SG, D (SG), LF, Cl. B) ..	6.1.34	PW34B
Fury Four Super (SG, SG, D, Pen) ..		PW34C
Battery Hall-Mark 4 (HF Pen, D, Push-Pull) ..		PW46
Mains Operated.		
Two-valve : Blueprints, 1s. each.		
A.C. Twin (D (pen), Pen) ..		PW18
A.C. D.C. Two (SG, Power) ..	7.10.33	PW31
Selectone A.C. Radiogram Two (D, Pow.) ..		IW19
Three-valve : Blueprints 1s. each.		
Double-Diode-Triode Three (HF Pen, D.D.T., Pen) ..	10.6.33	PW23
D.C. Ace (SG, D, Pen) ..	15.7.33	PW25
A.C. Three (SG, D, Pen) ..		PW29
A.C. Leader (HF Pen, D, Power) ..	7.4.34	PW35C
D.C. Premier (HF Pen, D, Pen) ..	31.3.34	PW35B
Ubique (HF Pen, D (pen), Pen) ..	28.7.34	PW36A
Armada Mains Three (HF Pen, D, Pen) ..	18.8.31	PW38
F. J. Camm's A.C. All-Wave Silver Souvenir Three (HF Pen, D, Pen) ..	11.5.35	PW50
"All Wave" A.C. Three (D, 2LF (R.C.)) ..	17.8.35	PW54
A.C. 1936 Sonotone (HF Pen, HF Pen, Westector, Pen) ..	31.8.35	PW56
Four-valve : Blueprints, 1s. each.		
A.C. Fury Four (SG, SG, D, Pen) ..		PW20
A.C. Fury Four Super (SG, SG, D, Pen) ..		PW34D
A.C. Hall-Mark (HF Pen, D, Push-Pull) ..		PW46
Universal Hall-Mark (HF, Pen, D, Push-Pull) ..	9.2.35	PW47
SUPERHETS.		
Battery Sets : Blueprints, 1s. each.		
£5 Superhet (Three-valve) ..		PW40
F. J. Camm's 2-valve Superhet (two-valve) ..	13.7.35	PW52
F. J. Camm's £4 Superhet ..		PW58
Mains Sets : Blueprints, 1s. each.		
A.C. £5 Superhet (three-valve) ..		PW43
D.C. £5 Superhet (three-valve) ..	1.12.34	PW42
Universal £5 Superhet (three valve) ..		PW44
F. J. Camm's A.C. £4 Superhet 4 ..		PW59
F. J. Camm's Universal £4 Superhet 4 ..	11.1.36	PW60
SHORT-WAVE SETS.		
Two-valve : Blueprints, 1s. each.		
Midget Short-Wave Two (D, Pen) ..	15.9.34	PW38A
Three-valve : Blueprints, 1s. each.		
Experimenter's Short-wave Three (SG, D, Power) ..		PW30A
The Perfect 3 (D, 2 LF, RC and Trans.) ..	8.2.36	PW63

PORTABLES.		
Three-valve : Blueprints, 1s. each.		
F. J. Camm's ELF Three-valve Portable (HF Pen, D, Pen) ..	16.5.34	1W65
Four-valve : Blueprints, 1s. each.		
Featherweight Portable Four (SG, D, LF, Cl. B) ..		FW12
MISCELLANEOUS.		
S.W. Converter-Adapter (1 valve) ..		PW48A
AMATEUR WIRELESS AND WIRELESS MAGAZINE CRYSTAL SETS.		
Blueprints, 6d. each.		
Four-station Crystal Set ..		AW427
1934 Crystal Set ..		AW444
150-mile Crystal Set ..		AW450
STRAIGHT SETS. Battery Operated.		
One-valve : Blueprints, 1s. each.		
B.B.C. Special One-valver ..		AW387
Twenty-station Loud - speaker One-valver (Class B) ..		AW449
Two-valve : Blueprints, 1s. each.		
Melody Ranger Two (D, Trans.) ..		AW388
Full-volume Two (SG, Det, Pen) ..		AW392
B.B.C. National Two with Lucerne Coil (D, Trans.) ..		AW377A
Big-power Melody Two with Lucerne Coil (SG, Trans) ..		AW388A
Lucerne Minor (D, Pen) ..		AW426
A Modern Two-valver ..	July '36	WM409
Three-valve : Blueprints, 1s. each.		
Class-B Three (D, Trans, Class B) ..	22.4.33	AW386
New Britain's Favourite Three (D, Trans, Class B) ..	15.7.33	AW394
Home-Built Coil Three (SG, D, Trans) ..		AW404
Fan and Family Three (D, Trans, Class B) ..	25.11.33	AW410
£5 5s. S.G.3 (SG, D, Trans) ..	2.12.33	AW412
1934 Ether Searcher: Baseboard Model (SG, D, Pen) ..	20.1.34	AW417
1934 Ether Searcher: Chassis Model (SG, D, Pen) ..		AW419
Lucerne Ranger (SG, D, Trans) ..		AW422
Cosor Melody Maker with Lucerne Coils ..		AW423
P.W.H. Mascot with Lucerne Coils (D, RC, Trans) ..		AW337A
Mullard Master Three with Lucerne Coils ..		AW424
£5 5s. Three: De Luxe Version (SG, D, Trans) ..	19.5.34	AW435
Lucerne Straight Three (D, RC, Trans) ..		AW437
All Britain Three (HF Pen, D, Pen) ..		AW448
"Wireless League" Three (HF Pen, D, Pen) ..	3.11.34	AW451
Portable Three (SG, D, Pen) ..		WM271
£6 6s. Radiogram (D, RC, Trans) ..		WM318
Simple-tune Three (SG, D, Pen) ..	June '33	WM327
Economy-pentode Three (SG, D, Pen) ..	Oct. '33	WM337
"W.M." 1934 Standard Three (SG, D, Pen) ..		WM351
£3 3s. Three (SG, D, Trans) ..	Mar. '34	WM354
Iron-core Band-pass Three (SG, D, QP21) ..	June '34	WM362
1935 £6 6s. Battery Three (SG, D, Pen) ..		WM371
P.T.P. Three (Pen, D, Pen) ..	June '35	WM389
Certainty Three (SG, D, Pen) ..	Sept. '35	WM393
Minute Three (SG, D, Trans) ..	Oct. '35	WM396
All-wave Winning Three (SG, D, Pen) ..	Dec. '35	WM409
Five-valve : Blueprints, 1s. 6d. each.		
Super-quality Five (2HF, D, RC, Trans) ..	May '33	WM320
New Class-B Five (2SG, D, LF, Class B) ..	Nov. '33	WM340
Class-B Quadradync (2SG, D, LF, Class B) ..	Dec. '33	WM344
1935 Super Five (Battery Superhet) ..		WM379

These blueprints are full size. Copies of appropriate issues containing descriptions of these sets can in most cases be obtained as follows:— "Practical Wireless" at 4d., "Amateur Wireless" at 4d., "Practical Mechanics" at 7½d., and "Wireless Magazine" at 1/3d., post paid. Index letters "P.W." refer to "Practical Wireless" sets, "P.M." to "Practical Mechanics" sets, "A.W." refer to "Amateur Wireless" sets, and "W.M." to "Wireless Magazine" sets. Send (preferably) a postal order (stamps over sixpence unacceptable) to "Practical and Amateur Wireless" Blueprint Dept., Geo. Newnes, Ltd., 8-11, Southampton Street, Strand, W.C.2.

THORNTON HEATH SHORT-WAVE RADIO AND TELEVISION SOCIETY

A VERY enjoyable demonstration, illustrated by lantern slides, was given before the members of the Thornton Heath Short-Wave and Television Society at St. Paul's Hall, Norfolk Road, Thornton Heath, on Tuesday, September 15th, through the kindness of Messrs. Lissen, Limited. The Lissen three-wave-band battery receiver (Model 8165), three-wave-band Universal Mains receiver (Model 8130), All-wave A.C. Superhet (Model 8114), and the Bandspread Short-Wave 3 (Model 8120) were successfully demonstrated, reception on the 13-33-metre waveband being exceptionally good. The Secretary, Mr. James T. Webber, 368, Brigstock Road, Thornton Heath, will be pleased to hear from all readers interested in Short-Wave Reception and transmission.

THE CROYDON RADIO SOCIETY

THE Croydon Radio Society's programme committee have been busy preparing the new session's programmes, and as a result there will be the opening meeting on Tuesday, October 6th, at 8 p.m., with a lecture by the President, Mr. H. R. Rivers-Moore, on "My experiences with Microphones and Public Address." Extra accommodation is being provided for an estimated increase in attendance. In addition to popular events like pick-up and loud-speaker nights, the construction by members of a really high quality club set is being considered, cathode-ray tubes are to be demonstrated, short waves and television will be carefully examined, members' lectures will be encouraged, the latest commercial sets heard, and "Amphion," the famous music critic, will discuss the subject of what is heard from a receiver. All meetings take place in St. Peter's Hall, Ledbury Road, S. Croydon, and PRACTICAL AND AMATEUR WIRELESS readers are invited to attend. The new session's fixture card is waiting to be sent to any reader who cares to apply for one. Hon. Publicity Secretary, E. L. Cumbers, Maycourt, Campden Road, S. Croydon.

WEST LONDON RADIO SOCIETY

THE 5-metre Field Day which was to have been held on Sunday, September 27th, has been postponed until Sunday, October 4th. All those who wish to attend should meet outside, the Lido Cinema, West Ealing, at 10 o'clock. On Wednesday, October 7th, at 8.30 sharp, there will be a general meeting of all members in Ealing Town Hall. All members, prospective members, and friends are cordially invited. At this meeting, the first of the winter season, the President, Douglas Walters, G5CV, will demonstrate his new all-wave superhet. Tuning from 600-5 metres, it delivers 15 watts undistorted output.—H. A. Williamson, Hon. Sec., 22, Camborne Avenue, Ealing, W.13.

BOOKS RECEIVED

THE RADIO ANTENNA HANDBOOK. By the Engineering Staff of "Radio." Published by Radio Ltd., 7460 Beverly Boulevard, Los Angeles, U.S.A. Price 2s. 6d.

THIS handbook should prove of great interest to the experimenter who desires to obtain the best results from his short-wave receiver or transmitter. It commences with a discussion of the underlying principles governing the action of the aerial-earth system, a clear explanation of such terms as skip distance, ground waves, sky waves, frequency, wavelength, and aerial radiation being given. The advantages and disadvantages of the various aerial types are then dealt with, and succeeding chapters give details of all the modern aerial systems.

Two very interesting chapters are devoted to directive aerials and the operation of aerials on harmonics, and the data given in this connection is more complete than that found in the majority of advanced textbooks. Sketches, diagrams, and constructional details of many of the aerial systems described are given—including the rotary beam system—and although a good deal of theoretical matter is necessarily included, the presentation is essentially practical. A very instructive treatise on a much-neglected subject.



QUERIES and ENQUIRIES

Calibrated Dials

"I will be very pleased if you will let me know if it is possible to buy a pair of coils with a 2-gang condenser with dial marked with station names (for home construction)."—A. McA. (Edinburgh).

SO far as we are aware there is no condenser dial on the market marked with station names, except where supplied complete in a receiver. The majority of good modern condensers are, however, supplied with dials marked in wavelengths in metres (or frequencies in kilocycles), and these are designed for use with coils of a definite inductance value. Good modern coils are wound to this value as agreed between the components manufacturers, and thus if you buy good coils of well-known make, with a similar type of condenser, you will be able to use the

A Wireless Mast

"Could you recommend a book dealing with the construction of lattice-work masts? I wish to construct a 40ft. mast, and I think an ordinary pole would be both unsuitable and unsightly. The type of mast I have in mind is similar to pylons carrying 'grid' systems, only constructed, of course, in wood."—L. B. (Cardiff).

AN efficient mast of this type was described in *The Wireless Magazine* for May last, but the total height was 30ft. The additional 10ft. could be obtained by slightly modifying the upper section, but you must bear in mind that the increased wind resistance may result in some risk of a collapse in a gale, and for all general purposes we think that you will find that a height of 30ft. is adequate for all normal purposes. The most suitable way of erecting the mast was described in the June issue of *The Wireless Magazine*. These two back numbers may be obtained from this office, price 1s. each, or 1s. 3d. by post.

A S.W. Adapter

"Could you please give me any information regarding a circuit of a short-wave adapter for use with an 'Ekco' all-mains set?"—E. W. (Mapperley).

YOU do not state whether the all-mains set employs H.F. amplification, and if it does, then a converter would be of more use. In any case, details of the receiver are necessary in order to recommend the most suitable S.W. unit. If the set is a superhet there may be some anti-whistle device which will prevent the satisfactory functioning of a converter, and in such a case you should communicate with the makers of the set in order to ascertain whether or not the converter would function. Blueprint PW48A describes a unit which may be used either as an adapter or converter, with battery or mains supplies and we recommend this particular unit.

Back Lash

"I have come across the term 'back lash' and I cannot find out what it is. I shall be obliged if you would tell me; also does it take place in the variable condenser, or in the slow-motion drive? My trouble is that I have decided to get a tuning condenser of the right capacity for the Simple Single Valve S.W. set. I cannot decide between two condensers, one with S.M. drive and one without."—H. W. (Bolton).

THE correct use of the term is in respect to the operation of the slow-motion drive. As the control knob is manipulated the condenser vanes should be turned, and when a reverse movement is applied the vanes should immediately reverse. If back-lash is present it will be found that when the movement of the control knob is reversed it must be turned through some short distance before the drive is again picked up.

Auto Radiogram

"I have been using a home-made radiogram for over two years now, and find my most interesting listening periods are with gramophone records. I am perfectly satisfied with the quality of reproduction, but should like to make use of an automatic record changer, if it is possible to construct one. Can you give me any details as to construction as I am keen on improving the set in this direction?"—G. T. (Paisley).

WE do not think you could make a satisfactory job of constructing a record repeating device. In any case, it is not necessary to do this, as complete record changers are now obtainable from two or three firms. Messrs. Garrard and Collaro, for instance, make complete radiogram units consisting of a baseplate, motor, turntable and record-changing mechanism, which may be mounted on your radiogram cabinet in place of the existing motor, and all controls are fitted on the plate. The prices are £10 and 10 guineas and fitting is a matter of a few minutes. A pick-up is supplied with these units and further details may be obtained by communicating with the firms mentioned.

Three-pentode Circuit

"I am interested in the pentode valve and have two high-frequency pentodes and one super-efficiency output pentode, which I should like to combine into one circuit. I think it would be quite practicable to use the H.F. pentode as an H.F. amplifier and the output pentode in its normal position, with the remaining valve as a detector, but I am not certain regarding the coupling and best method of arranging the circuit. Could you let me have any details for this and hints on operation?"—F. R. (Lowestoft).

WE have described a receiver of the type mentioned, and a blueprint is available for the construction of the receiver. This was the Silver Souvenir, blueprint PW49. An alternative arrangement and one which will be found to provide better results, is to use the two H.F. pentodes as H.F. amplifiers, and to use a Westector as the detector, following this by the usual pentode output stage. Such a circuit is used in our 1936 Sonotone, blueprint PW53, and this receiver may also be built for mains operation, blueprint PW56 showing the constructional features.

Tone Control

"I wish to cut the bass a little on my set, which is rather too deep. The set is designed on quality lines. What is the best arrangement to adopt?"—F. T. (Preston).

INSTEAD of cutting the bass, the treble may be boosted, and this can be done to a degree by placing in series with the anode resistance of an R.C. coupling a circuit consisting of an inductance and condenser in parallel, of such values that they form a resonant circuit having a natural frequency of the order of 6,000 cycles. It must be remembered, however, that the effect of this device is only to improve the relative proportions of such frequencies as exist in the signal leaving the detector. It cannot put back that which is filtered out in the pre-detector stages, and that is why it is best to tackle the problem in the high-frequency section of the receiver.

RULES

We wish to draw the reader's attention to the fact that the Queries Service is intended only for the solution of problems or difficulties arising from the construction of receivers described in our pages, from articles appearing in our pages, or on general wireless matters. We regret that we cannot, for obvious reasons—

- (1) Supply circuit diagrams of complete multi-valve receivers.
- (2) Suggest alterations or modifications of receivers described in our contemporaries.
- (3) Suggest alterations or modifications to commercial receivers.
- (4) Answer queries over the telephone.
- (5) Grant interviews to querists.

Please note also, that queries must be limited to two per reader, and all sketches and drawings which are sent to us should bear the name and address of the sender.

If a postal reply is desired, a stamped addressed envelope must be enclosed. Send your queries to the Editor, PRACTICAL AND AMATEUR WIRELESS, George Newnes, Ltd., 8-11, Southampton Street, Strand, London, W.C.2.

The Query Coupon MUST be enclosed.

calibration, and there is no real necessity to have station names engraved if the wavelengths are given. In the event of any station changing its wavelength the name type of dial would be rendered obsolete, but the wavelength type of dial would still hold good.

Masonite Board

"In a back number you described the construction of a box baffle. I should be glad if you could give me the name and address of the suppliers of the Masonite board which was specified for this baffle."—N. B. (Glasgow).

THE board was supplied by the Weedon Power Link Co., of 262, Romford Road, Forest Gate, London, E.7, but we understand that no further supplies are now available. A good substitute is "Tentest," a building material of similar construction, and you should be able to obtain this at any good builder's yard.

**OUR NEW
STABLE COMPANION!
THE CYCLIST**
2d. Every
Wednesday.

The coupon on page iii of cover must be attached to every query.

Miscellaneous Advertisements

Advertisements are accepted for these columns at the rate of 3d. per word. Words in black face and/or capitals are charged double this rate (minimum charge 3/- per paragraph). Display lines are charged at 6/- per line. All advertisements must be prepaid. All communications should be addressed to the Advertisement Manager, "Practical and Amateur Wireless," 8, Southampton Street, Strand, London.

RADIO CLEARANCE

63, HIGH HOLBORN, W.C.1:

TEL.: HOLBORN 4631.

The Mail Order House with World-Wide Reputation. Quality goods and satisfaction assured.

ANNOUNCING GREATER BARGAINS THAN EVER IN GUARANTEED RADIO.

Price £8.19.6 PLETTY 6-VALVE ALL-WAVE A.C. RECEIVER, wave-range 15-2000 metres 9 1/2". Auditorium speaker. Provision for external speaker and pick-up. Handsome Walnut cabinet of modern design. Brand new. Made for export. To sell at 20 gns. EXCLUSIVE AMERICAN RIGHTS HELD BY US FOR CONSTRUCTRAD SHORT-WAVE KITS. All kits supplied valves free. Five interchangeable coils covering a range from 15-4000 metres. Complete set not a converter.

29/6 One-valve battery Kit.

37/6 Two-valve battery Kit.

37/6 One-valve A.C./D.C. Kit.

49/6 Two-valve A.C./D.C. Kit.

£5.19.6 EVER READY 5-VALVE BATTERY S/H. Incorporating A.V.C. large square-type dial, provision for pick-up and extension speaker. Listed 12 gns. Stocks are limited, order at once to avoid disappointment.

39/6 LISSEN 4-VALVE A.C. RECEIVER. Complete with valves. P.M. Moving-Coil speaker, handsome horizontal cabinet. S.G. Det. Pen. Rectifier.

70/- LISSEN 4-VALVE A.C. BAND PASS RECEIVER. A quality job listed at £9 15s. 0d. Sent out aerial tested, complete with valves.

55/- LISSEN BATTERY BAND PASS RECEIVER, complete with valves.

35/- LISSEN 3-VALVE PLUS BARRETTA D.C. RECEIVER. Fitted handsome horizontal Walnut Cabinet. Complete with valves.

35/- ALBA H.F. PEN., DETECTOR, PEN., 3 VALVE CHASSIS, brand new, fitted Mullard valves. AC/DC AMERICAN MIDGET, 5-valve type, a real quality job, Jensen moving coil speaker, etc., brand new, boxed.

17/6 GRAMPIAN P.M. MOVING COIL SPEAKER, 7 1/2" cone, fitted in handsome Walnut cabinet of modern design, 10 range variable volume control Multi transformer.

BRYCE MAINS TRANSFORMERS AND CHOKES, standard for the season, finest made, British and guaranteed.

8/6 250-0-250, 80 m.a., 2-0-2 volts, 2.5 amp., 2-0-2 volts, 4 amp.

10/6 350-0-350, 120 m.a., 2-0-2 volts, 2.5 amp., 2-0-2 volts, 4 amp.

12/6 350-0-350, 150 m.a., 2-0-2 volts, 2.5 amp., 2-0-2 volts, 4 amp.

17/6 500-0-500 volts, 150 m.a., 2-0-2 volts, 2.5 amp., 2-0-2 volts, 6 amp., 2-0-2 volts, 2 amp. 2-0-2 volts, 2 amp.

8/6 H.T. 8 transformer, 250 volts, 60 m.a., 2-0-2 volts, 4 amp.

17/6 Ditto with H.T. 8 metal rectifier.

ALL TRANSFORMERS ARE FULLY SHROUDED. MAINS CHOKES.

4/6 40 m.a. 30 henrys.

6/- 60 m.a. 40 henrys.

10/6 150 m.a. 40 henrys.

21/- 250 m.a. 15 henrys.

6/- 60 m.a. 80 henrys, 2,500 ohms for speaker replacement, etc.

12/6 SPECIAL CLEARANCE CHOKE, 250 m.a. 12 henrys, 100 ohms heavy duty type, interleaved windings, etc. Cannot be repeated.

TRIAD AMERICAN VALVES, highest quality. All types 5/6 each as follows: 01-A, 24A, 27, 30, 31, 32, 33, 35, 37, 38, 39, 41, 43, 45, 46, 47, 53, 55, 56, 57, 58, 59, 71A, 75, 78, 80, 6A0, 1C6, 0F7, 2A3, 5Z3, 12A7, 6A7, 6C6, 6D6, 12Z3, 25Z5.

ALL these valves carry a 90-day guarantee and free replacements provided that the filament or heater is intact and the glass is not broken when returned to us.

3/6 LISSEN CLASS B VALVES brand new, boxed.

(Continued at top of column three)

PREMIER SUPPLY STORES

SHORT WAVES.

SHORT-WAVE COILS 4- to 6-pin types. 13-20, 22-47, 41-94, 78-170 metres, 1/9 each with circuit. Special set of 3 S.W. Coils, 14-150 metres, 4/-, with circuit. Premier 3-band S.W. Coil, 11-25, 18-43, 33-86 metres. Simplifies S.W. receiver construction, suitable any type circuit, 2/9.

COIL FORMERS, in finest plastic materials, 1 1/2 in. low-loss ribbed, 4- or 6-pin, 1/- each.

CONDENSERS, super ceramic S.L.F. .00010, .0001, 2/9 each; double-spaced .00015, .00025, .00035, 3/- each. All brass with integral slow-motion .00015 tuning, 3/9; .00015 reaction, 2/9.

SHORT-WAVE KIT for 1 valve receiver or adaptor, complete with chassis, 3 coils 14-150 metres, condensers, circuit, and all parts, 12/6.

VALVE GIVEN FREE. De Luxe Model, 17/6.

2-VALVE S.W. KIT, complete with valves, 19/6.

3-VALVE S.W. KIT, S.G., Det., and Pen. complete with valves, 40/-.

Telsen iron-cored coils W.349, 4/- each.

PREMIER (Reiz Pattern) transverse current microphone, 30/-; transformer 5/-.

SPEAKERS, MAGNAVOX. Mains energised. '154', 7" cone, 2,500 ohms 4 watts, 12/6; '154 Magna', 5 watts, 25/-; '152', 9" cone 2,500 ohms, 17/6; '152 Magna', 9" cone, 2,500 ohms, 6 watts, 37/6. Magnavox P.M.'s-'254', 7" cone, 16/6; '252', 9" cone, 22/6. Reliable P.M.'s, 10/6; Cossor P.M.'s, 13/6.

MAINS TRANSFORMERS. Premier wire-end type with screened primaries. H.T. 8 & 9 or H.T. 10 with 4v. 4a C.T. and 4v. 1a C.T., 8/6.

250-250v. 60 m.a., 4v. 1a., 4v. 2a. and 4v. 4a., all C.T., 8/6.

350-350v. 120 m.a., 4v. 1a., 4v. 2a., and 4v. 4a., all C.T., 10/6.

500-500v. 150 m.a., 4v. 2-3a., 4v. 2-3a., 4v. 2-3a., 4v. 3-4a., all C.T., 19/6.

Any of these transformers with engraved panel and N.P. terminals, 1/6 extra.

AUTO TRANSFORMERS, step up or down, 60 watts, 7/6, 100 watts, 10/-.

MAINS VALVES, famous Europa 4v. A.C. types, 4/6 each. H.L., L., S.G., Var.-Mu-S.G.; H.F. Pens., Var.-Mu-H.F. Pens., 1, 3, and 4-watt A.C. directly-heated output Pentodes. Full-wave rectifiers, 250 v. 60 m.a. A.C./D.C. types, 20volt, 13 amp. S.G., Var.-Mu-S.G., H., H.L., and Power.

Following types all 5/6 each. Full-wave rectifiers 350v. 120 m.a. and 500v. 120 m.a. 2 1/2 watt indirectly-heated Pentodes. Frequency Changers. Octodes and Heptodes.

BATTERY VALVES. 2-volts, H.F., L.F., 2/3. Power, Super-Power, 2/8. S.G., Var.-Mu-S.G., 4- or 5-pin Pentodes, H.F. Pens., V.-Mu-H.F. Pens., 5/-, Class B, 3/6.

AMERICAN VALVES. Genuine American DUOTRON, all types, 3/6 each. Hytron super quality, 3 months' guarantee, all types, 5/6.

MILLIAMMETERS, moving-iron flush 2 1/2", all ranges from 0-10, 5/9. Visual tuning, 6 or 12 m.a., 5/-. Moving coil meters, 2 1/2" 0-1 m.a. 18/6; 3 1/2" 0-1 m.a., 22/6. Multipliers, 1/- each. Westinghouse meter rectifiers, 17/6 each.

ELECTROLYTICS. U.S.A. 1, 8 or 12 mfd. 530 v. peak, 1/9 each. Dutilier, 4 or 8 mfd. 500 v. 3/-; 50 mfd. 50 v., 1/9; 12 mfd. 20 v., 6d.; 25 mfd. 25 v., 1/-; T.C.C. 4 or 8 mfd. 550 v., 4/-; 15 mfd. 50 or 100 v., 1/-; 50 mfd. 12 v., 1/-.

Paper Condensers. W.B., 250 v. working 4 mfd., 2/-; 2 mfd. 1/-; 1 mfd. 6d.; 250 v. working 4 mfd., 2/6. 2 mfd. 1/6. Dutilier 500 v. working 4 mfd., 4/-; 800 v. 4 mfd. 6/-; 2 mfd. 750 v. 3/-.

Wego 450 v. working 1 mfd. 1/-, 2 mfd. 1/9, 4 mfd. 3/-; 700v. working 2 mfd. 2/-, 4 ufd. 3/6; 1,550 v. working 1 mfd. 3/6.

TRANSFORMERS, latest type Telsen R.G.4 (list 12/6), 3/6. Telsen Hypernik Q.P.P. (list 12/6), 2/9.

ELIMINATOR KITS for A.C. Mains. 120 v. 20 m.a., 150 v. 25 m.a., 10", tapped S.G. det. and output. Complete Kit with long-life valve rectifier (replacement cost only 2/-).

LISSEN ALL-ELECTRIC A.C.4. S. Grid. Det., Pen. and Rectifier, M.C. Speaker. (List £9.9.0). Our price 65/-.

Potentiometers by well-known makers. All values up to 1 meg. 2/-; with switch 2/6.

GRAMOPHONE MOTORS. Collaro, Gramophone Unit, consisting of A.C. motor, 100-250 v. high quality pick-up and volume control, 45/-; motor only 30/-; Collaro Universal Gramophone motor, 100-250 v. A.C./D.C., with high quality pick-up and volume control, 67/6; Universal Motor only, 49/6; Edison Bell double spring motors, including turntable and all fittings, 15/-; Cosmocord Gramo unit, comprising A.C. motor, pick-up and volume control (list 55/-), 35/9.

ALL POST ORDERS should be addressed to—JUBILEE WORKS, 167, LOWER CLAPTON RD., LONDON, E.5.

*Phone Amherst 4723 (Private Branch Exchange). Callers, as usual, to 20-22, HIGH ST., CLAPHAM, S.W. 4 (Macaulay 2381).

and 156 and 165a, Fleet St., E.C.4 (next to Anderson's Hotel). (Central 2833).

NOW READY! Send 4d. in stamps for NEW ILLUSTRATED GIANT CATALOGUE AND VALVE LIST.

(Continued from foot of column one)

7/6 SET OF 3 LISSEN BAND-PASS COILS, iron core, screened, without switching, complete with circuit.

9d. LISSEN R.C.C. UNITS.

2/6 8 mid. And 4 mid. ELECTROLYTICS, 450 volt working, 500 volt peak, well-known make.

6d. 1 WATT WIRE END RESISTANCES, well-known make, all values.

10/6 P.M. MOVING-COIL SPEAKER, 6in. CONE. By well-known manufacturer.

13/6 P.M. MOVING-COIL SPEAKER, 7in. CONE. By well-known manufacturer.

3/6 MULTI-PURPOSE VALVE suitable for H.F. Pentode. List 2s.

2/- LISSEN 126 KC/S I.F. TRANSFORMER, fully screened.

2/- G.E.C. 110 KC/S I.F. TRANSFORMER, fully screened, midget type with trimmers.

6d. TUBULAR CONDENSERS, wire end type, all sizes up to 1.

1/6 LISSEN CENTRE TAPPED CHOKES) Brand new, boxed.

1/- LISSEN INTER-VALVE CHOKES. Brand new, boxed.

3/11 UTILITY 3-GANG S/H CONDENSER. Comprising 2, .0005 sections, and 100 kc/s section. Fully screened with top trimmers.

5/11 MIDGET 2-GANG .0005 CONDENSER fully screened, top trimmers. By well-known manufacturer.

2/6 DUPLEX AERIALS. Brush type. Supplied with 50 foot lead in and all fittings.

£5.15.0 1 ONLY MAGNAVOX A.C. MODEL 68. List £7 17s. 6d. Used few hours only.

A SUPER BARGAIN.

Hours of Business, 9 a.m. to 7 p.m. Saturdays, 9 a.m. to 1 p.m.

All orders value 5s. and over Post Free. Orders under 5s. must be accompanied by a reasonable amount for postage.

Enquiries, 1d. stamp if reply expected.

RADIO CLEARANCE

63, HIGH HOLBORN, W.C.1.

TEL.: HOLBORN 4631.

RECEIVERS, COMPONENTS AND ACCESSORIES

Surplus, Clearance, or Secondhand, etc.

BIRMINGHAM RADIOMART G5N1.—Everything a constructor requires, lowest prices, no junk; catalogue, 1d., shows thousands bargains; during summer few only shown below.

RADIOMART. Huge purchase Cossor 1936. Super-ferrodyn receivers half price, £2/19/6. Stamp for full list.

RADIOMART. Telsen screened dual range coils, 2/6. Pair 4/6. Milliammeters, 25ma. upwards, 5/9. Super, 6/9.

RADIOMART. American mains transformers 230 v. fully shrouded, 350/350. 6.3v., 5v., 6/11. Majaestic 250/250. 2.5v., 5v., 4/11.

RADIOMART. Heavy duty mains transformer worth 35/- 350/850. 150 ma.; 4v.2.5ACT. 4v6ACT. 12/6.

RADIOMART, 465 kc/s, I.F., transformers, 2/11. BTH speaker transformers, 2/11. Telsen Acc. 1/11. RG4, Radiograms, 2/9.

RADIOMART. Utility straight line wavelength dials, 3/11. Telsen H.F. chokes, 1/11.

RADIOMART. Utility 2-gang unknob and dial, 3/11; 1,500-volt tubular condensers, 6d.; Helsby electrolytes, 8 mf. 500, 2/11; 4 x 4 mf., 1/11; 25 mf. 25 volt, 1/-; etc.

RADIOMART. Smoothing chokes, 20 hy. 120 m.a., 3/11; 100 m.a., 2/11; 40 m.a., 1/11.

RADIOMART. Pushback wire, 6 yds. 6d.; heavy 9d.; 2 gross solder tags, 6d.; resin-cored solder, 9ft. 6d.

RADIOMART. Centralab pots, all sizes, 1/6; switched, 2/-; tubular glass fuses, 2d.

RADIOMART. Lissen 3-gang superhet kit coils, two I.P.'s, ganged condenser, ditto bandpass, ditto 2-gang all-wave, 10/- kit.

RADIOMART. Traders' monster bargain parcels, value £4/10/-, for 10/-; also 5/- parcels.

RADIOMART. Famous Continental A.C. valves, 4/6; American Duotron, etc., all types, 3/6; battery from 2/3.

RADIOMART. Utility 8/6. microdisc dials, 3/11; Radiophone, 0.00016 short-wave condensers, 3/8; series zap, twin, 3/9.

RADIOMART. Ceramic all brass microvariables, 15 minfd., 1/4; 40 mmfd. 1/7; 100 mmfd., 1/10; short wave H.F.C., 9d.

RADIOMART. Order 5/- post free; get our bargain catalogues; General 1d., Short wave 1d.—44, Holloway Head, Birmingham. Tel.: Mid 8254.

WE BUY for cash, all types of Modern Second-hand Radio Sets, Accessories, etc. Unbeatable Part-exchange allowances for new goods. Bring, send or write.

UNIVERSITY RADIO LTD., 82, Hampstead Road, London, N.W.1. *Phone: Euston 3810.

RECEIVERS, COMPONENTS AND ACCESSORIES
Surplus, Clearance, or Secondhand, etc.

SOUTHERN RADIO'S WIRELESS BARGAINS. ALL GOODS GUARANTEED AND SENT POST PAID.

SPEAKERS.—Celestion Soundex Permanent Magnet, 10/-; Telsen Permanent Magnet with ten-ratio transformer, 12/6; Blue Spot 99P.M. Extension Speaker, 20/-; 45P.M. Extension Speaker, 17/6; Telsen Loud Speaker Unit, 2/6; all new and boxed.

RECEIVERS.—G.E.C. A.C. D.C. Mains Three-valve sets. Complete with 3 Osram Valves, in exquisite Bakelite cabinet with Osram M.C. Speaker. Ready to plug in to any mains. Fully guaranteed. New, in sealed cartons, £3/5 (list £7/15).

G.E.C. Compact 3-valve Battery Sets complete with 3 Osram valves, moving coil P.M. Speaker in attractive Bakelite cabinet, makers' 1926 series in original sealed carton, 50/- (list £5/10/0).

TEISEN A.C. D.C. MULTIMETERS (latest 1936 type).—5-range for every conceivable test for radio and domestic electrical appliances, 8/6 each.

COILS.—TEISEN (1936). Iron-cored Coils, Type W349, midsize, 4/-; type W478 (twin), 9/- pair; type W477 (triple), 16/-; type W476 (triple superhet selector and oscillator), 16/- set. All Ganged Coils are Mounted on Base with switch. I.F. Transformer Coils W482, 5/-; Telsen Dual Range Coil with variable series condenser W76, 4/-.

MICROPHONES.—Ace (P.O.) Microphones, complete with transformer, perfect with any type of receiver, 4/6.

TRU-OHM RESISTANCES.—1 Watt. Wire ends colour coded and marked; 30 assorted capacities on card, 6/-.

AMERICAN VALVES.—A full range of valves for all American sets at 7/- each. Brand new, guaranteed.

SOUTHERN RADIO BRANCHES.—271/275, High Road, Willesden Green, N.W.10; 46, Lisle Street, W.C.2. All mail orders to 323, Euston Rd., N.W.1.

SOUTHERN RADIO, 323, Euston Rd., London, S.W.1 (near Warren Street Tube). Phone: Euston 3775.

CONVERSION UNITS for operating D.C. Receivers from A.C. Mains, improved type, 120 watts output, at £2/10/0. Send for our comprehensive list of speakers, Resistances and other components.

WARD, 46, Farringdon Street, London, E.C.4. Telephone: Holborn 0703.

ALL goods previously advertised are standard lines, still available. Post card for list free.

VAUXILIARY UTILITIES, 163a, Strand, W.C.2. Over Denny's the Booksellers, Temple Bar 9339.

ERIE Resistors, 6d.

TRANSFORMERS, L.F., 3-1 and 5-1, 2/6d.

AMERICAN Valves, best make, guaranteed, any type, 5/9d.

BATTERY Valves, best makes, 2v., Detector 2/8d.

S.G. 8/11d. Super Power, 3/6d.

MULLARD Short-wave Adaptor Kit; with valve, 42/6d.

CONDENSERS.

CHOKES.

ELIMINATOR3.

Enquiries welcome. Stamp for lists.

MULLARD, 169, Fulham Palace Rd., London, W.6. (Mail order only.)

HEADPHONES. From 2/6 pair. Postage 6d.

Brown, G.E.C., B.T.H., Neaper, Ericsson, etc.

List free.

CRYSTAL SETS. Complete. Guaranteed. Burne-Jones. 5/6. Ditto, double circuit, 8/-.

Crystal detectors. Complete parts, 1/-.

Sensitive permanent detectors, 1/6. Post Radio, 183, Caledonian Road, London, N.1.

SITUATIONS VACANT

DO YOU WANT A PROFITABLE BUSINESS OF YOUR OWN? We show you exactly how to start and run a business with little capital from your own address. No office, shop or experience is necessary. You receive working details of 201 profit-earning businesses from which to make an immediate start. No risks. No waiting. Results are sure. Just send a p.c. today—NOW—for fully descriptive FREE Book to Business Service Institute (Dept. 68Y), 6, Carmelite Street, London, E.C.4.



£7
6 VALVE ALL-WAVE SUPERHET

(Complete with B.V.A. Valves)

All-wave band-pass superheterodyne for A.C. or D.C. mains. High sensitivity on all three wave-bands (16.5-50 metres, 200-550 metres, 800-2,000 metres). Many interesting features, including:—

Illuminated "Airplane" dial with station names. Special "squelch" valve for inter-station noise suppression, with manual muting control. Octode frequency changer. 8 stages, 7 tuned circuits. Position on switch connects pick-up terminals. Delayed A.V.C. 3.5 watts output.

£7 cash complete with valves, knobs, pilot lamps, mains cable and plug, etc. Deferred terms from London Radio Supply Co., 11, Oat Lane, E.C.2. 12 months' guarantee. Suitable loudspeakers, cabinets, etc., in stock.

McCarthy Chassis from £4 5s. to £12. Write for illustrated catalogue.

MCCARTHY RADIO LTD.

44a, Westbourne Grove, London, W.2.

Telephone: Bayswater 2201.

Engineers' Guide

containing the widest choice of engineering courses in the world

Outlines The T.I.O.B.'s up-to-date home-study Courses in Wireless, Electrical and Mechanical Engineering, etc. Shows how to become A.M.I.E.E., A.M.I.W.T.

A.R.A.S., etc., and how to qualify for a well-paid post. Training until Successful—Guaranteed. WRITE NOW for Free Guide THE TECHNOLOGICAL INSTITUTE OF GREAT BRITAIN, 42, Temple Bar House, London, E.C.4. (Founded 1917. 19,000 Successes.)



To Success

ADVERTISEMENT INDEX

	Page
British Institute of Engineering Technology	81
Clarion Radio	81
Cossor, A. C., Ltd.	Inside Front Cover
Edison Swan Electric Co., Ltd.	Back Cover
Electradix Radios	87
Holmes, H. W.	87
International Correspondence Schools, Ltd.	86
King's Patent Agency	Inside Back Cover
Lectro Link, Ltd.	73
London Radio Supply Co.	87
McCarthy Radio, Ltd.	Inside Back Cover
Peto-Scott Co., Ltd.	81
Player's Airman Tobacco	73
Record Radio, Ltd.	Inside Back Cover
Technological Institute of Gt. Britain	Inside Back Cover
Varley	Inside Back Cover

NEW RECEIVERS, COMPONENTS, AND ACCESSORIES

HULBERT for Quality Surplus Speakers. All Music Lovers should write for List of amazing bargains. Prices from 8/6 brand new. Made by best known British maker.—Hulbert, 6, Conduit Street, W.1.

RADIO BARGAINS

AMAZING Prices. New and Shop-soiled Mains and Battery Sets. Components. American. English Valve replacements. Stamp for list.—LITTLER, 2, Barras Lane, COVENTRY.

VALVES

VALVES. By well-known manufacturer. Complete range of Battery, A.C. Mains, Rectifiers. Brand new stock with six months' guarantee. 2 volt Detector, 2/3, Power, 2/3, Screen Grid, Pentode, H.F. Pentode, 5/-. The following American type valves, fully guaranteed, at 5/6 each: No. 80, 42, 43, 57, 58, 77, 78, 6C6, 6D6, 25Y5, 25Z5. Write for other prices to: Dulci Electrical Co., Ltd., 7, Lizard Street, London, E.C.1.

3S. EACH any popular type of American valves. 90 days' guarantee. Orders 10/- or over Carriage Paid. Satisfaction or Money Refunded immediately. **RADIOGRAPHIC LIMITED**, 66, OSBORNE STREET, GLASGOW, C.1.

MISCELLANEOUS

REPAIRS to Moving Coil Speakers, Cones and Coils fitted or rewound. Fields altered. Prices Quoted including Eliminators. Loud-speakers Repaired, 4/-. L.F. and Speech Transformers, 4/- post free. Trade invited. Guaranteed. Satisfaction. Prompt Service. Estimates Free. L. S. Repair Service, 5, Balham Grove, London, S.W.12. Battersea 1321.

ALCO ELIMINATORS AND CHARGERS.—4 HT-taps, 120v/150v, 20/30 m.a., 18/- With 1/2 amp. charger, 25/-; charger alone, 7/6. 1/2 amp., 11/- Years guarantee. Details free.—P. & D. Radio, 1, Gooding Road, N.7.

BANKRUPT BARGAINS. List free. GEC Compact 3v, BVA valves, MC, 42/6. Telsen AC 6v superhets, complete, £5/12/6. Lotus 4v AC/DC midgets MC, 65/- Ferguson 12v, AC/DC allwave superhet, 14gu. Cossor DC 3v SG, 72/6. Ferguson, Pilot, Truphone latest allwave sets. Car radio. Large stock valves components. Anything radio supplied. Get my price first. Part exchange. All goods advertised are brand new.—Butlin, 6, Stanford Avenue, Brighton.

RECORD
The quality valve in the COMPLETE range
RECORD RADIO LTD., 2/3, Eldon Street, E.C.2

PATENTS AND TRADEMARKS.

KINGS PATENT AGENCY (Director: B. F. King, Patent Agent.) Advice, Handbook and Consultations free.—146a, Queen Victoria Street, E.C.4. Phone: City 6161.

FREE ADVICE BUREAU COUPON
This coupon is available until October 10th, 1936, and must be attached to all letters containing queries.
PRACTICAL AND AMATEUR WIRELESS,
3/10/36.

Varley FOREMOST AS PIONEERS
SCREEN GRID BATTERY 3 WITH PENTODE OUTPUT VALVE. Incorporating our new BP 114 Unit. Send to-day for blueprint. Price 3d. Post Free.
OLIVER PELL CONTROL, LTD., BLOOMFIELD ROAD, WOOLWICH, S.E.18 WOOLWICH 2345

EDISWAN RADIO

high fidelity reproduction units

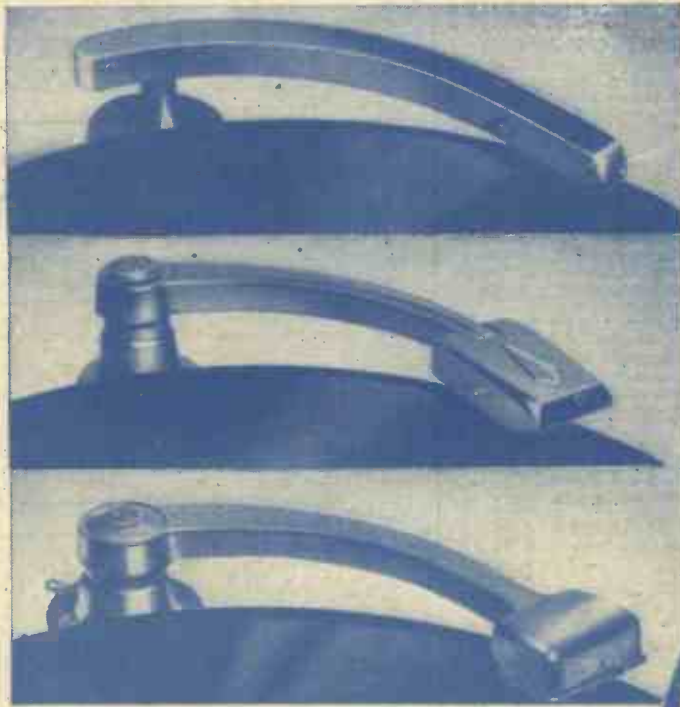

MICROPHONES

A beautifully finished instrument in Cellulose black with chromium-plated grille, ideal for public address work, etc. It is very sensitive and has an excellent frequency response curve. It may be used with any suitable amplifier by connecting in series with a 6-volt battery capable of giving 20 milliamps and the primary of a 30-1 step-up transformer.

Microphone - £2.12.6. Microphone and Stand - £3.10.0

Ask your local dealer for particulars and descriptive leaflets of these Ediswan Radio Products.

Mazda Radio Valves are manufactured in Great Britain for the British Thomson-Houston Co. Ltd., London and Rugby, and distributed by:



THE EDISON SWAN ELECTRIC CO. LTD., 155 Charing Cross Rd., London, W.C.2



PICK-UPS

Designed by engineers who understand the meaning of fidelity in reproduction.

B.T.H. Piezoelectric Power Pick-up - 42/-
 B.T.H. Needle Armature Pick-up - 40/-
 B.T.H. Improved Minor Pick-up - 17/6



HEAD TELEPHONES

A newly designed light-weight unit of great sensitivity, giving excellent reproduction, even of weak signals.



Easily adjustable moulded ear-pieces, chromium-plated headband and stirrups fitted with approx. 5 feet of cord with pin tips. Weight 8oz. Resistance 4,000 ohms. Price 12/6



TELEVISION FOR CONSTRUCTORS—AN IMPORTANT ANNOUNCEMENT

Practical and Amateur Wireless

3^d
EVERY
WEDNESDAY

Edited by F. J. CAMM

a GEORGE
NEWNES
Publication

Vol. 9. No. 212.
October 10th, 1936.

AND PRACTICAL TELEVISION

Making an

ADD-ON

Superhet
Unit



EVERYMAN'S WIRELESS BOOK

By F. J. CAMM (Editor, "Practical and Amateur Wireless," etc.)

A Radio Consultant for the Listener, Expert and Amateur Constructor, explaining the Operation, Upkeep and Overhaul of all Types of Wireless Receivers, with Special Chapters on the principles of Radio Telephony, Installation, and Systematic Fault-finding.

With
200

From all Booksellers only 3/6 net. or 3/9 post free from

GEORGE NEWNES, LIMITED, 8-11, Southampton Street, Strand, LONDON, W.C.2. Illustrations



The WORLD
at your
finger-tips!

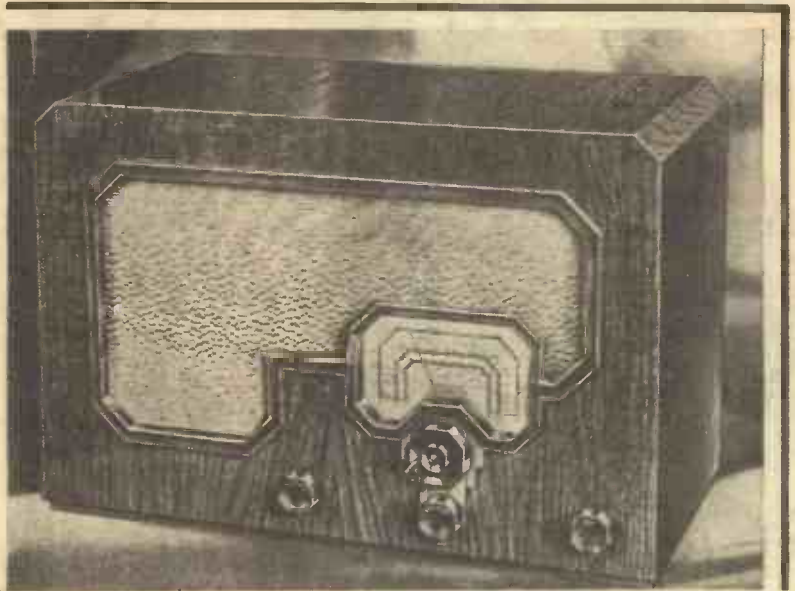

All-wave Receivers Models 3733 and 3783.



The de luxe Superhet Models 3774 and 3764.

with
COSSOR
ALL-WAVE RADIO
FOR MAINS AND BATTERY OPERATION

Here is all-wave Radio to suit every need—and pocket. Four receivers, any one of which will give you the thrill of long distance reception—America, Australia, Africa—the whole world at your finger tips! And European listening at its best, too. Ask your radio dealer to let you hear the 3733 or 3783—the “straight” receivers that, at the touch of a switch, become superhets for the short waves. You’ll be surprised.

de luxe SUPERHETS
FOUR RANGES: 13/16 to 40, 38 to 100,
195 to 550, 1000 to 2000 metres.

BATTERY MODEL 3774
(7 VALVES)

Class “B” output. Full vision wavelength scale with station names. Special slow motion single-knob tuning. Combined volume control. Tone control. 8” permanent Magnet Moving Coil Speaker. Magnificent Cabinet.

13GNS

Hire Purchase Terms: (less batteries)
12 months: 25/- deposit and 12 payments of 23/-
18 months: 25/- deposit and 18 payments of 16/3

A.C. MAINS MODEL 3764
(6 VALVES Inc. rect.)

Special slow motion single-knob tuning. Illuminated wavelength scale with station names. Combined volume control. Tone control. 8” Concert Grand Moving Coil Speaker. Magnificent cabinet. For A.C. Mains only. 200/250 volts (adjust.) 40/100 cycles.

15GNS

Hire Purchase Terms:
12 months: 30/- deposit and 12 payments of 26/6
18 months: 30/- deposit and 18 payments of 18/6

ALL-WAVE RECEIVERS
with Short-Wave Superhet Circuit

3 WAVE BANDS: 17.25 to 52.5 metres on Superhet Circuit,
200/560, 826/2000 metres.

BATTERY MODEL 3733

With special Pentagrid, H.F. Pen. Det. and Economy Pen. Output Valves. Super-selective coils with special switching, giving variable- μ screened grid circuit on medium and long waves, Superhet circuit on short waves. Special slow motion tuning. Full vision wavelength scale with station names. Precision reaction control and volume control. 8” M.C. Speaker. Superb cabinet with accommodation for batteries.

£7.15.0

Hire Purchase Terms: 12 months: 10/6 deposit and 12 payments of 13/9
18 months: 10/6 deposit and 18 payments of 10/-

A.C. MAINS MODEL 3783

Generally similar to Battery Model 3733 but with 3 A.C. Mains valves including special Triode Hexode and rectifier and with illuminated dial. For A.C. Mains only. 200,250 volts (adjustable) 40/100 cycles.

£9.15.0

Hire Purchase Terms: 12 months: 17/- deposit and 12 payments of 16/9
18 months: 17/- deposit and 18 payments of 12/-

Prices do not apply in I.F.S.

A. C. COSSOR LTD., Highbury Grove, London, N.5.

CIRCUIT REFINEMENTS EXPLAINED —See page 97



Practical and Amateur Wireless

Edited by F. J. CAMM

Technical Staff:
W. J. Delaney, H. J. Barton Chapple, Wh.Sc.,
B.Sc., A.M.I.E.E., Frank Preston.

VOL. IX. No. 212. October 10th, 1936.

ROUND *the* WORLD of WIRELESS

B.B.C. Recording Vans

THE B.B.C. outside equipment is now further augmented by two recording vans. These may be booked by Regional stations for local recording and will lend colour to local programmes. The cars are 23 feet long and over 10 feet in height, and each is entirely self-contained with its own battery supplies. In addition, special generators are carried so that the batteries may be kept in good condition. A complete miniature studio is arranged behind the driver's cabin, and this is fitted with a raised glass roof through which the commentator or announcer can gain a view in all directions.

Indian Air Radio

SHORT-WAVE apparatus is now being installed on the Indian aerodromes to enable greater traffic to be handled. The present long-wave apparatus, working on a wavelength of 900 metres is found to be inadequate owing to the greatly increased air traffic. At present, the long wavelength will be used for communication between aircraft, and the short-waves for inter-aerodrome communication.

Television File

THE intermediate film apparatus is now being adapted to enable a file of television events to be kept, in the same manner as the Marconi-Stille (Blattnerphone) apparatus is used for sound programmes. This will enable repetitions to be made, and will also lend itself to the production of composite programmes of a historical nature in the future. It will also enable the B.B.C. to supply local television transmitters, or even Dominion transmitters with records of national events for re-broadcasting.

New Australian Station

A NEW broadcasting station is to be built at Perth. The apparatus is at present undergoing test at Sydney and great things are expected of it. In addition VK2ME, Melbourne, is being re-designed and rebuilt.

Progress in Russia

IT is announced that the Soviet intend to build fifteen stations varying in power from 100 to 150 kW. in European Russia, to be followed by five similar stations in

Asia. What is claimed to be the largest loud-speaker in the world was recently installed at Leningrad Stadium, and is stated to deliver an audio output of 20 kilowatts.

Television 'Phones

IN Germany more 'phone lines are being equipped with television apparatus so that the users of the telephone may also see each other. Some remarkable distances have been covered in experimental tests

been developed in the U.S.A. which provides a remarkable expansion circuit. A novel noise-suppressing circuit has also been developed which suppresses all noises such as static, electrical interference, etc., and leaves a signal clear without background.

An Unusual Accident

IN a motoring accident recently in Denmark a motorist collided with a mast carrying three electric light cables, using the three-wire system. The collision caused the centre wire to break and it came into contact with one of the outer. This resulted in the supply to one district being completely cut off, but in another district the houses all received double the normal supply. The result was a complete burn out of hundreds of wireless receivers, electric lamps and other appliances. It's an ill wind—

B.B.C. Television

THE B.B.C. announced that following the experimental demonstrations of television at Radiolympia a period of trial transmissions began on Thursday, October 1st, the transmission times being from 11.0 a.m. to 12.0 noon and 3.0 p.m. to 4.0 p.m. Details of the transmissions are not to be regularly announced, but the public will be kept informed of the system to be used and of any change in the hours. For the first week the Baird system was employed, and this week the Marconi-E.M.I. system. Subsequently each system will be used in alternate weeks. There will be no transmissions on Sundays.

In U.S.A.

IT is recorded that at an American broadcasting station a deaf and blind news announcer is employed. A girl secretary reads the bulletins and the announcer feels her lips and throat in order to "hear" the items, which he then repeats over the microphone.

Last year's American advertising expenditure is stated to have reached the vast figure of £20,000,000. The majority of this went to artists.

Binding Cases and Indexes

BINDING cases and indexes for volume 8 of PRACTICAL AND AMATEUR WIRELESS are now available. The binding case, complete with title page and index, costs 3s. 6d., and the index alone 7d. by post.



The Bound Volume of "Practical and Amateur Wireless" is uniform with the first volume here shown. See paragraph on this page.

with this type of equipment, which is housed in a booth very little larger than the standard 'phone booth now so familiar in our streets.

American Circuits

IN America some interesting new circuit developments are now being incorporated in commercial receivers. Volume expansion has already been dealt with by us, and a new multi-electrode valve has now

THE PICK of the PROGRAMMES

Operatic Programme

ON October 17th, Midland Regional listeners will hear the first part of the City of Birmingham Orchestral concert which will be given in the Birmingham Town Hall. Leslie Heward will be the conductor, and the programme will consist of music from a number of operas, including "The Perfect Fool," by Holst; "Hansel and Gretel," by Humperdinck; "Samson and Delilah," by Saint-Saëns; and "A Life for the Czar," by Glinka.

"Twinkle"

THIS broadcast, presented and produced by Clarkson Rose, will be heard from the Pavilion, Bath, on October 13th. The cast includes Clarkson Rose, the comedian who appeared at the Royal Command Performance at the London Coliseum in 1928; he writes most of the original lyrics and sketches. The leading lady is Olive Fox.

Concert from Torquay

THE Torquay Municipal Orchestra, conducted by Ernest W. Goss, will broadcast a concert from the Pavilion, Torquay, on October 13th, when Gwen Catley (soprano) will be the vocalist.

Orchestral Music

INCLUDED in the forthcoming programmes of orchestral music, the following items are of special interest. On October 10th (National) Frank Bridge will conduct "La Boutique Fantasque" (Rossini-Respighi) and the Overture to "Donna Diana," by Reznicek, a Viennese composer who was born in 1860. The opera "Donna Diana" dates from 1894 and was first performed in Prague. The First Symphony of Sibelius will be broadcast on October 11th, National, conducted by Clarence Raybould, and on the same day (Regional) Leslie Woodgate and the B.B.C. Singers will perform a programme of music by Edward German. Isolde Menges will play Saint-Saëns' "Introduction and Rondo Capriccioso" with Warwick Braithwaite conducting, on October 12th (Regional). Isobel Baillie will sing with the Empire Orchestra, conducted by Eric Fogg, on October 15th (National).

Variety from Bedford

JENNY HOWARD (comedienne) will be the principal turn in a variety bill to be broadcast on October 13th from the Royal County Theatre, Bedford.

"London's Latest"

UNDER the title of "London's Latest" an amusing revue by Rex London will be broadcast on October 8th and 10th from the National and Regional respectively.

MAKE THESE DATES WITH YOUR RADIO

Headed by Rex London, the cast includes Janet Lind, Raymond Newell, Florence Oldham, Edward Cooper, Miriam Ferris, and

TRIPLETS AND TELEVISION



The Mauby Triplets, who are appearing in the new musical play at the Savoy Theatre, "Going Places," trying out a G.E.C. Television Receiver.

Horace Percival. The cast will be supported by the Variety Orchestra conducted by Ernest Longstaffe.

Midland Composer's Concert

JOHAN HOCK will conduct the Birmingham Philharmonic String Orchestra, on October 13th, in a programme of works by three Midland composers, namely, the late

SOLVE THIS!

PROBLEM No. 212.

Holder wanted to fit a variable-mu H.F. pentode valve with bias potentiometer control in place of the S.G. valve in his battery receiver. His set incorporated a tuning unit in which the earth end of the grid coil was internally connected to the chassis, however, and therefore the normal method of connecting the volume control to this point could not be adopted. What alternative method of connecting the control could be adopted? Three books will be awarded for the first three correct solutions opened. Address your letters to the Editor, PRACTICAL AND AMATEUR WIRELESS, Geo. Newnes, Ltd., 8-11, Southampton St., Strand, London, W.C.2. Envelopes must be marked Problem No. 212 in the bottom left-hand corner, and must be posted to reach this office not later than the first post Monday, October 12th, 1936.

Solution to Problem No. 211.

Herbert could use a resistance having a value of between 10,000 and 20,000 ohms; 15,000 ohms is generally a very satisfactory value.

The following three readers successfully solved Problem No. 210, and books have accordingly been forwarded to them: J. W. Neale, 108, Brampton Road, St. Albans, Herts.; R. B. Turner, 34, Elm Road, Leigh-on-Sea; D. R. Vincent, 9, Dawson Road, Handsworth

Sir Edward Elgar, Sir Granville Bantock, and Frederick Bye, the Birmingham 'cellist.

Saxophone Solos

LESLIE ROGERS will broadcast a fifteen-minute interlude of saxophone solos in the Western programme on October 14th.

City of Bristol Police Band

THIS popular band, under the direction of Captain F. W. Wood, will be heard by Western listeners on October 14th. Maisie Griffiths (contralto) will be the vocalist.

Variety from Morecambe

LISTENERS to the Northern Regional on October 14th will hear a variety programme from the Winter Gardens, Morecambe. The bill, from which an excerpt will be taken, includes Donald Peers and pianist; Nell and Gwynne (lady accordionists); Van Dusen (yodeller), and the Cole Brothers (harmonica duettists).

Midland Symphony Concert

THE first part of the City of Birmingham Orchestra's Symphony Concert from the Town Hall—their first this season—will be broadcast on October 8th. Leslie Heward is the conductor, and the leader of the orchestra is Alfred Cave. The broadcast portion of the programme will consist of Glinka's overture to "A Life for the Czar," César Franck's symphonic Poem "Les Eolides," and Dvorák's D minor Symphony.

Tewkesbury Abbey's Organs

IN the "Midland Organs and Organists" series, Captain Percy Baker, M.C., organist of Tewkesbury Abbey since 1910, will describe the two organs in the Abbey and give a recital on October 9th.

Birmingham City Police Band

ON October 11th Richard Wassell will conduct the Birmingham City Police Band, the foremost police band in the country, in a programme which includes "Finlandia," by Sibelius, arranged by Winterbottom, and Elgar's "Sursum Corda."

Orchestral Concert

CLARENCE RAYBOULD is the guest conductor of the B.B.C. Midland Orchestra in the concert on October 16th. The programme will include Havergal Bryan's comedy overture, "Dr. Merryheart." Mr. Raybould will also conduct the orchestra's symphony concert in the afternoon.

W.B. STENTORIAN SPEAKER RESULT.

We hope to publish this next week.

AUTOMATIC INDICATING DIALS

How to Modernise Your Tuning Scale to Provide Automatic Indication of the Range to which the Receiver is Tuned

By W. J. DELANEY

A LARGE proportion of the Radio Wrinkles which we receive relate to the modification or improvement of the tuning dial, and it appears that this provides the greatest interest so far as a modification of the external appearance of the modern wireless receiver is concerned. Many of the modern commercial receivers are fitted with tuning scales which are automatically changed when the wave-range switch is operated, and in others, coloured indicating lights are operated to indicate which range of the tuning coil is in circuit. But the home-constructed receiver may be improved still further if certain types of tuning dial are employed and the following details give several suggestions for incorporating such indicating aids. The first requirement for any of these devices is some form of switching from one dial light to another, and therefore such switching must be carried out at the same time as the coil switching, otherwise the value of the device will be lost.

Dial-light Switching

In the case of the simple receiver covering only the two broadcast bands, it will only be necessary to fit a change-over switch so that either one of two lights may be used. To this may be added, if required, a further switch to put out both lights

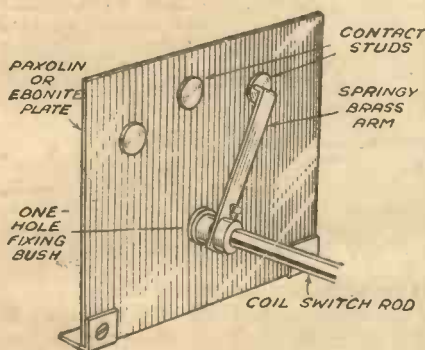

Fig. 2.—A home-made switch to work in conjunction with a coil switch.

when gramophone record reproduction is required, but in this case the switch should be employed in conjunction with the radio-gram switch. If the set is of the very simple kind employing a simple push-pull on/off switch for wave-changing purposes, a similar type of switch, but of the single-pole change-over type, should be ganged with it for the dial lights. This may be carried out in a very few moments, and with very little skill, simply by attaching a component mounting bracket to the baseboard or chassis and connecting the threaded end of the plunger to the end of

the wave-change switch. The latter generally has a pear-shaped plunger built up of metal with an ebonite end for the "off" position. This may be unscrewed and where the two switches are of the same make the thread will be found to fit the knob end of the switch, thus enabling the two to be joined together in a moment. Fig 1 shows the completed combination.

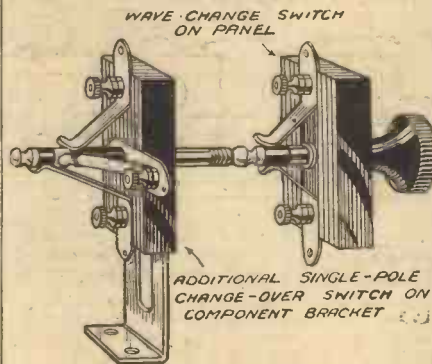

Fig. 1.—Ganging two switches together to effect wave-changing and dial-light switching.

Care will have to be taken regarding the wiring for the dial light as in this case the two control spindles may be connected together and there will thus be a risk of short-circuiting the L.T. supply. However this point will be explained later. A similar combination may be used when a three-point push-pull switch is employed for wave-change purposes.

Self-contained Switches

Where a coil or coil combination having its own self-contained wave-change switch is employed, the dial-light switching will have to be incorporated on the coil unit, and the exact method will depend upon the type of coil which is employed. On many modern coils the spindle is extended at the end in order that an on/off switch may be incorporated and in this case the constructor may make up a rotary switch to operate from the spindle in place of the on/off switch. If sufficient mechanical skill is possessed, it may even be possible to combine the on/off switch on the same unit, but there are very few coil units which will enable this to be done without replacing the switch spindle. Therefore, each coil unit will have to be considered individually.

If insufficient room is available at the end of the switch rod, the simplest scheme is to obtain a length of ordinary brass rod of the same diameter as the switch rod, and connect this to either the front or rear of the coil switch rod by means of a short length of ebonite or brass tubing, provided with grub-screws. The most suitable type

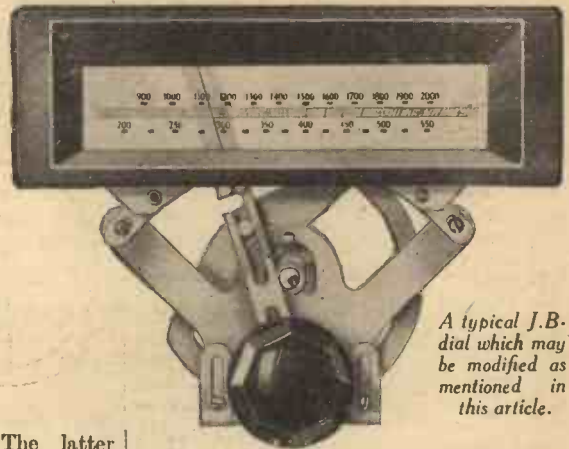

A typical J.B. dial which may be modified as mentioned in this article.

of switch then to incorporate is that made up from a flat strip of paxolin or ebonite upon which are mounted small contact screws in the form of an arc. To the switch spindle a short arm of springy brass is then attached and this will wipe across the contact screws. The latter may be the properly designed switch studs, ordinary cheese-head machine screws, or even brass paper fasteners. The general idea is shown in Fig. 2. All of the necessary parts may be obtained from any wireless accessory store or direct from Messrs. Bulgin.

The general remarks just given should enable everyone to be able to incorporate a suitable switch with their coil unit, no matter whether this is of the simple type with push-pull on/off switch, or a multi-coil unit covering four wavebands. The next problem is how to incorporate the various lamps to provide the most useful indication as to the setting, and it is here that most ingenuity and originality may be shown. In the simplest form, coloured bulbs may be mounted behind the dial, using a separate colour for each waveband. In the most comprehensive form, the dial itself may be divided up at the rear, with each bulb enclosed in the division which is calibrated for the separate wavebands, and thus only that part of the dial in use will be illuminated. Unfortunately there are very few dials on the market which lend themselves to the latter arrangement. The modern J.B., Polar, and Utility dials are, however, admirably suited for the conversion, and if those with wavelength calibrations are obtained (with which, of course,

(Continued overleaf)

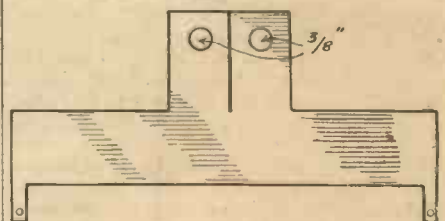

Fig. 3.—How to cut out a metal strip to use with a dial of the type shown above. Modifications for different makes of dial will suggest themselves to the constructor.

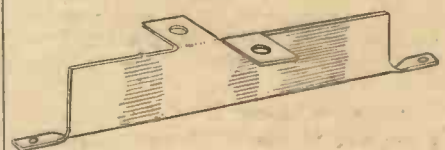

Fig. 4.—The strip should be bent as shown here. The tabs which hold the bulbs should be bent to provide the best lighting effect.

AUTOMATIC INDICATING DIALS

(Continued from previous page)

the correct coil inductance must be employed), the following modifications may be carried out.

The Horizontal Dial

In the horizontal type of dial, some models have the long wavelengths and the medium wavelengths arranged one above the other, with a central portion calibrated simply in degrees. In this type of dial the conversion may be carried out by cutting a piece of tin to the shape shown in Fig. 3. The length will depend upon the length of the tuning scale, but the short tabs at the end should be made so that when twisted and bent outwards (as shown in Fig. 4), they will go over the bolts which are used to attach the escutcheon to the panel. The two large projections at the rear should be drilled with a $\frac{1}{8}$ in. hole into which a standard flash-lamp bulb will screw. These lugs must then be bent so that one bulb is raised above the tin strip and one is held below, and the exact angle should be found by trial so that only one half of the scale is illuminated at a time. The return circuit for both lamps is, of course, taken from the tin strip.

Airplane Dials

The J.B. airplane dial lends itself particularly well to modifications, the external flange being divided into two and held in position by means of a short bolt. A strip of tin may be attached vertically behind the dial and each side of the scale used for each waveband in the case of standard types of coil, but for all-wave tuners the dial may just as easily be divided into four separate sections. To clear the spindle the

centre of the vertical strip must be bent as shown. For a three-band tuner, of course, the centre part of the vertical strip should be omitted. The dial as supplied by the makers will not be suitable for an all-wave tuner, but the disc of celluloid which

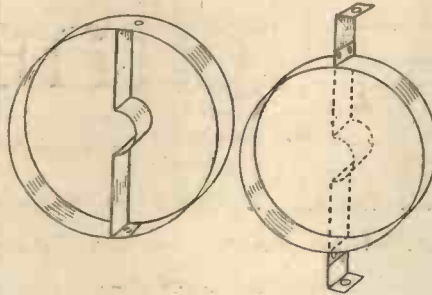

Fig. 5.—Accessories for addition to an airplane dial for selective indication.

is used in the dial may be removed and a new piece of celluloid inserted in its place. With the majority of dials this course will have to be adopted in any case, and the new markings will have to be made thereon. The best method of doing this is

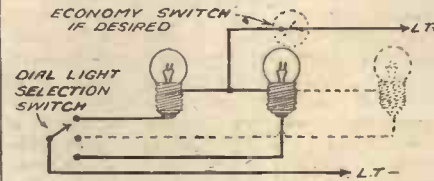

Fig. 6.—How to wire the dial-lights for use in the arrangements described in this article.

to write them on the back of the dial, using good drawing ink for the purpose, and writing with a fine drawing or mapping pen. The surface of the celluloid should be prepared for the writing by rubbing down slightly with fine emery powder (ordinary knife powder). In case the writing of names or figures presents a slight difficulty, due to the fact that they must be written backwards, they may first be written out on thin tracing paper, and this may then be turned over and the reverse markings copied. An alternative is to stick the thin tracing paper to the back of the celluloid, although this will naturally affect the transparency of the dial. There will be no need to use coloured inks as the wave-ranges will automatically be illuminated when the appropriate lamp is brought into circuit.

The Type of Lamp

A final word may be given concerning the type of lamp. In the case of battery receivers ordinary pocket-lamp bulbs should not be used, as in many cases a single bulb of this type will consume more current than the entire receiver. Special low-consumption bulbs are obtainable from good wireless stores. Similarly, in an A.C. mains receiver, the bulb should be of the 6-volt type, and not of the 4-volt type. To effect an economy an ordinary on/off switch may be connected in the dial light circuit so that it may be switched off after the set has been tuned, but if the correct type of lamp is obtained this precaution is unnecessary.

THE BEST WEEKLY FOR CYCLISTS
THE CYCLIST
2d. WEEKLY

RANDOM JOTTINGS

The French Radio Exhibition

Although in previous years strong efforts have been made to suppress references to television at the French Radio Exhibitions, a different state of affairs existed at the autumn exhibition held at the Grand Palais, Paris. Three large halls were devoted entirely to television and three systems were featured, although pride of place was given to that of Barthélémy, since it is his equipment which has been installed in the Eiffel Tower station with the co-operation of the Ministry of P.T.T. The public were able to see actual stage television transmissions and then observe the results on the screens of television receivers to which the generated signals were passed. It is stated that in order to reduce the large amount of light previously required by the Barthélémy system a new camera incorporating an electron multiplier has been developed, and it is hoped to install this in the Eiffel Tower studios very shortly. The Poste Parisien station was also demonstrating television, but up to the present Government permission has not been given to the station actually to transmit pictures. A number of television receivers were on show, the prices ranging from 4,000 to 10,000 francs, depending upon picture size and whether ordinary radio reception was included in the set or not.

sions seen at Radiolympia. Some were enthusiastic in their praise, others took an entirely opposite point of view and spoke of television as being debunked. The general consensus of opinion, however,

was to the effect that the pictures seen were better than had been thought possible. Certain technical defects did arise during the ten days of programmes, but as the transmitting station was only hurriedly put into commission with a bare week for aerial tests prior to Radiolympia's opening, in fairness to the engineers and authorities concerned it must be stated that the results were most creditable.



Our illustration shows a policeman listening-in to headquarters with his pocket-radio from the scene of a recent fatal car crash, at Roedean nr. Brighton.

Contrary Views

It was both interesting and amusing to read the reports of newspaper correspondents dealing with the television transmis-

Circuit Refinements Explained

By H. J. BARTON CHAPPLE, B.Sc., A.M.I.E.E.

By Appreciating the Full Value of Modern Circuit Refinements, Better Results can be Secured with Home-constructed Sets

IN the complete set market, receiving practice is becoming fairly well crystallised, with two main types of set outstandingly popular—the three-valve straight receiver and the superhet. Moreover, the difference in overall performance of any two sets in either class is governed mainly by the selection of those devices referred to frequently as “circuit refinements,” which the maker has incorporated; and the

The frequency-changer stage, however, has undergone many alterations. Up till quite recently the choice of valve for this stage had been between a valve of the electron-coupled type, that is a pentagrid (heptode) or octode, and an arrangement such as the triode-pentode which consists in essence of a triode oscillator and pentode mixer which, for the sake of convenience, are mounted in one bulb. Figs. 1 and 2 show respectively the basic circuits of the octode and the triode-pentode, and it will be seen that the former is the simpler by virtue of the fact that the coupling between the oscillator and the mixer portions is “electronic,” i.e., it takes place within the electron stream of the valve, so that no external coupling is required. The octode, however, falls short of perfection in regard to frequency stability on the short waves, and the latest “refinement” in frequency changers is the use of the triode-hexode, a type comprising a triode oscillator and a hexode mixer, both in the same bulb and with a common cathode, but with the electrodes so inter-connected that, as seen in Fig. 3, the basic circuit combines the technical advantages of a separate oscillator and mixer with those of the electron-coupling principle.

than remind the reader that when, by a multiplicity of tuned circuits, a set is made sufficiently selective to give interference-free reception of stations occupying adjacent channels, i.e., whose signals are separated by a frequency difference of 9 kilocycles, practically no musical frequencies above 4,500 kilocycles reach the detector stage. Any attempt to give a better approximation to natural reproduction, which should include frequencies

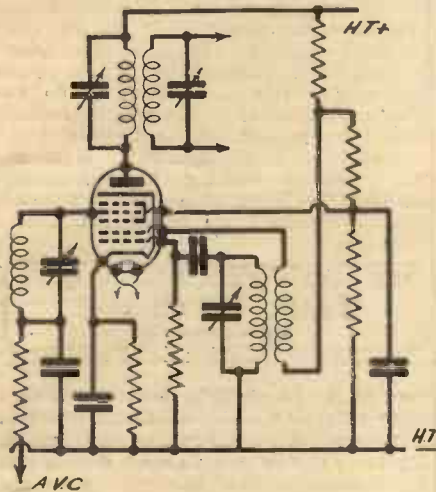

Fig. 1.—Basic circuit of octode frequency changer (electron coupling).

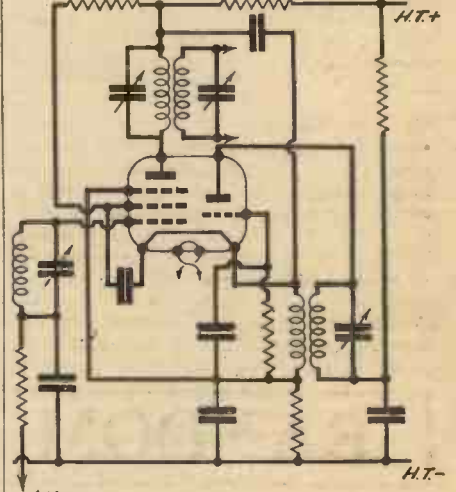

Fig. 2.—Basic circuit of triode-pentode (cathode coupling).

number of such refinements depends generally upon the price the listener is prepared to pay. To-day, for a given sum of money, a set has a greater number of these improvements than ever before. Some of them are often used by home constructors, and the requisite components for all these devices can usually be obtained to-day, and the improvements in performance which they can effect fully justifies the expenditure of a little time and money.

To assist those who have hitherto not become familiar with these circuits and devices, the following explanation of a number of modern refinements may be of service.

The First Case

Starting first with the simple three-valve straight set, there is comparatively little by way of novel refinements which can be recommended. Such strides have been made in superhet design that many of the disadvantages which once militated against the development of a “quality” superhet have now disappeared. The straight circuit, therefore, is usually employed for inexpensive local station receivers, although, of course, it will receive the more powerful foreigners and, in favourable circumstances, has a still better range.

So far as tuning is concerned, nothing need be said about the band-pass filter which has been available for some years, and is now almost universally adopted.

Variable Selectivity

The next refinement to be described is not exactly new, but is to-day available

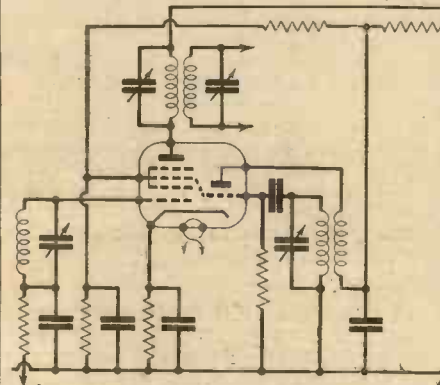

Fig. 3.—Basic circuit of triode-pentode frequency changer, which is almost identical with that of Fig. 1.

in a larger number of commercial receivers than ever before, and should be adopted in more home-constructed sets than at present. Known as “variable selectivity” it aims at minimising, at least as far as the more powerful stations are concerned, the unnaturally deep-toned quality which in the past has so frequently characterised the reproduction from a highly selective superhet receiver. There is no need to do more

up to at least 10,000 kilocycles, must be limited to devices incorporated in the low frequency circuits and calculated to suppress partially the obtrusive bass notes, and to give an abnormal degree of amplification to the small amount of treble which succeeds in penetrating to the detector. But in almost any district a certain number of stations produce field strengths so much greater than those of their neighbours in the wavelength scale that serious interference would not be heard even if the set was considerably less selective.

(Continued overleaf)

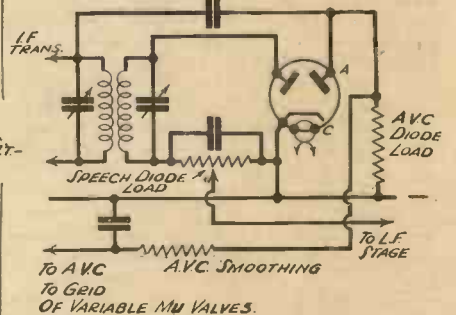

Fig. 4.—Basic circuit for simple A.V.C. The I.F. voltage is rectified by the diode system A.C., and the voltage drop across the A.V.C. diode load is applied to early stage valves as additional negative grid bias via a smoothing or decoupling circuit.

(Continued from previous page)

Band-pass Filters

Sets fitted with "variable selectivity" devices can be adjusted for either high selectivity when neighbouring stations of nearly equal strength are to be separated, or for broader tuning when it is desired to receive with the best possible quality one of the more powerful stations which are more favourably situated as regards interference. This is achieved by varying the coupling between the two tuned circuits forming one of the band-pass filters of the receiver, and invariably one of the intermediate-frequency transformers is selected for the purpose. As most listeners know, a band-pass filter consists of two circuits, tuned to slightly different frequencies, the coupling between them whether inductive or magnetic, being such that their resonance peaks combine to give a comparatively flat topped response curve and comparatively sharp frequency cut-off, thus passing only a limited band of frequencies on either side of the mid-point. For normal receivers the band-width is approximately 9 kilocycles, and this value is adjusted in ordinary sets by means of the trimmer condensers. Alteration of the coupling alters the band-width, and in "variable selectivity" sets this may be done either by varying the value of the coupling components or by altering the position of one coil with respect to the other. The latter system seems to be most favoured by set designers this season, and as variable coupling I.F. transformers can now be obtained from component makers there is no reason why it should not be used in many home-built sets.

Automatic Volume Control

For several seasons now, receivers of the superhet type have embodied automatic volume control for reducing the effects of fading, but to encourage those constructors who have not yet used this refinement because of the apparent complication of the circuit, it may be explained that the device consists simply of applying to the early stage valves of the receiver an additional and varying negative bias propor-

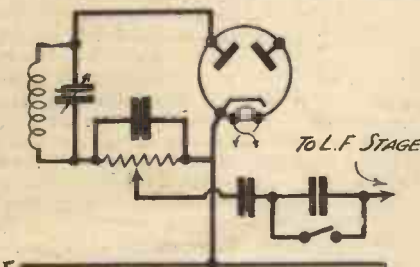

Fig. 7.—One method of bias control on the L.F. side.

tional to the strength of the incoming carrier wave. The effect of this on the variable-mu valves is to reduce amplification of strong signals. The variable bias is usually obtained from the rectified intermediate-frequency signal, a diode accommodated in the same bulb as the speech detector diode being used for the purpose. Fig. 4 shows the circuit for what is known as "simple" or "full" A.V.C., and the explanatory wording on the diagram should make the principle quite clear.

With this form of automatic volume control, a certain amount of extra bias is available even on the weakest signals, so that no station is received at maximum amplification, which is a disadvantage when listening to weak stations. In Fig. 5, however, an improved form of A.V.C., known as "delayed A.V.C.," is shown.

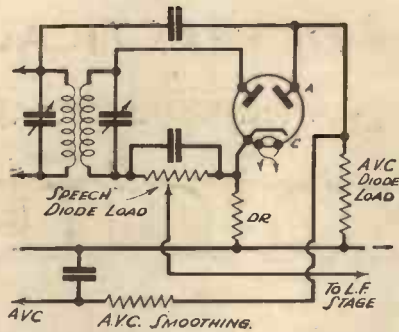

Fig. 5.—Basic circuit for delayed A.V.C. It is identical with Fig. 4 with the addition of the delay resistance DR which gives a positive bias to the A.V.C. diode AC. Unless the I.F. voltage applied to the diode exceeds this bias no current will flow through the A.V.C. diode load and no A.V.C. voltage will be produced.

Here, the inclusion of the resistance DR in the cathode circuit of the A.V.C. diode renders the cathode positive with respect to the diode anode, by an amount equal

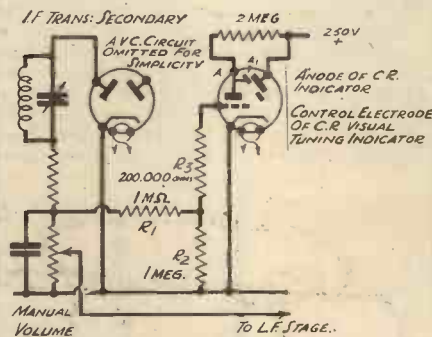

Fig. 6.—Circuit arrangement for C.R. visual-tuning indicator. The rectified H.F. voltage appears across the load resistances and a portion of it is applied via R₁ to the triode portion of the indicator as a varying negative bias. The corresponding variations in the anode current cause a varying voltage at A-A₁, thus altering the dispersion of the cathode ray.

to the voltage drop across DR, and until the I.F. signal applied to the anode exceeds this value, no A.V.C. bias is produced. Thus, with delayed A.V.C., weak signals are fully amplified, and only the stronger ones subjected to control.

Until quite recently, delayed A.V.C. could not conveniently be applied to battery sets because the cathode of the A.V.C. diode, being the filament, could not be given the necessary positive bias. Now, however, indirectly heated battery double-diodes are available, in which the cathode is isolated from the heater filament, permitting the arrangement shown in Fig. 5 to be used in battery sets.

Visual Tuning

A refinement which is also more general this year than previously, is the visual tuning indicator. As is well known, if a set not fitted with A.V.C. is detuned, the volume of sound decreases, and it is mainly by listening for maximum sound that the receiver is tuned. If A.V.C. is fitted, however, the action of this device tends to restore volume to normal even when the set is detuned, and it becomes difficult to judge by ear whether the receiver is correctly tuned or not, with the result that considerable distortion is often introduced by mistuning. A visual tuning indicator is a device showing at once whether the set is accurately tuned. It makes use of the fact that at the point of correct tuning the

A.V.C. bias is naturally of maximum value, and the anode current of the I.F. or other controlled valves is therefore at a minimum. The simplest form of indicator is a small meter connected in the anode circuit of the controlled valve or valves, minimum reading of the meter corresponding to optimum tuning. The meter may move a pointer over a scale or operate a shutter in front of a pilot lamp to give a small or larger area of light or of shadow.

In other indicators the voltage drop across a resistance in the circuit of the controlled valve is applied to a neon lamp, the varying length of the column of light showing correct tune. The latest device, however, consists of a miniature cathode-ray tube combined with a small triode valve in the same bulb. The triode grid is connected to the diode detector circuit in such a way that it is negatively biased in proportion to the signal strength. The anode current of the triode portion will thus be a minimum when the signal is correctly tuned and, as will be seen from the circuit reproduced in Fig. 6, the voltage drop across the resistance R will also be a minimum, so that the actual voltage at the anode A will be a maximum. An auxiliary electrode in the cathode-ray section of the indicator is connected internally to the triode anode, and as the voltage on this electrode increases, so the cathode ray is caused to diverge, illuminating more and more of the fluorescent screen. When detuned the fluorescence appears as a small cross, and the arms expand to almost completely cover the screen at maximum deflection. This form of indicator is considerably more sensitive than those of the meter type, and will give full indication for a rectified I.F. voltage of only 4.0 volts.

Most of the remaining circuit refinements found in modern sets are variants of the tone correctors which have been dealt with fully in recent issues of PRACTICAL AND AMATEUR WIRELESS. Mention may be made, however, of the fact that on speech and with certain types of gramophone records, it is sometimes an advantage to be able to tone down the bass a little. This may be

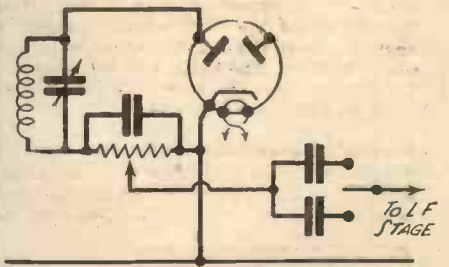

Fig. 8.—An alternative to the Fig. 7 arrangement

achieved either by a switch which inserts different values of coupling condenser in the L.F. circuit as indicated in Fig. 7, or by arranging two coupling condensers in series, one being normally short-circuited by a switch which is opened when less bass is desired. This is shown in Fig. 8, the values of the condensers being best ascertained by experiment.

Our New Stable Companion
The Cyclist
2d. Every Wednesday

A PAGE OF PRACTICAL HINTS

**SUBMIT
YOUR
IDEA**

READERS WRINKLES

**THE
HALF-
GUINEA
PAGE**

An Illuminated Dial Arrangement

THE accompanying sketch shows an effective method of illuminating a dial in different sectors as the tuning knob is turned. A semi-circular slot is cut in the panel behind which is fixed a curved strip

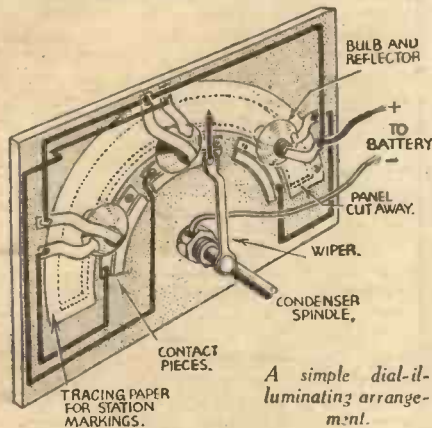

of tracing paper on which the station names are marked. Arranged behind this strip are three bulbs, the reflectors of which are fixed to the back of the panel by connecting strips. Three curved contact pieces are also fixed to the back of the panel, and the connections made as shown. A pointer is soldered to the condenser spindle, the top part being bent forward to form a rubbing contact with the curved strips, so completing the circuit of the bulb which illuminates that portion of the dial immediately in front of the pointer. The bulbs may be connected to a battery or L.T. supply.—R. C. BOWER (Warringham).

Fixing an Earth Lead

HAVING some difficulty with the fixing of an earth lead and trying for some time to hook the end of the wire from an

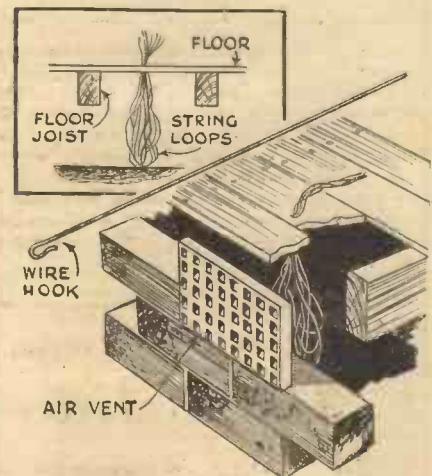

A method of getting an earth lead through an air vent in a brick wall.

THAT DODGE OF YOURS!

Every Reader of "PRACTICAL AND AMATEUR WIRELESS" must have originated some little dodge which would interest other readers. Why not pass it on to us? We pay £1-10-0 for the best wrinkle submitted, and for every other item published on this page we will pay half-a-guinea. Turn that idea of yours to account by sending it in to us addressed to the Editor, "PRACTICAL AND AMATEUR WIRELESS," George Newnes, Ltd., 8-11, Southampton Street, Strand, W.C.2. Put your name and address on every item. Please note that every notion sent in must be original. Mark envelopes "Radio Wrinkles." Do NOT enclose Queries with your Wrinkle.

outside air vent, I hit upon the following plan which successfully solved the problem. As the sketch shows, instead of trying to hook a single wire several loops of string are pushed through the hole in the floorboards, and then "fished" for with a piece

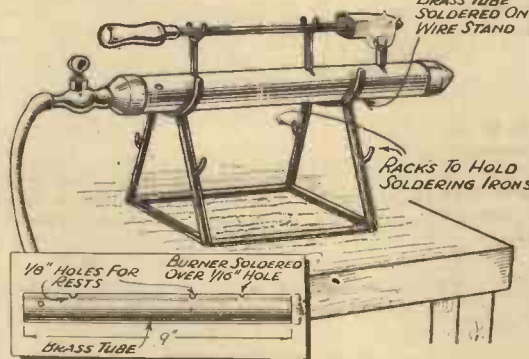

An economical gas-heater for soldering irons.

of stout wire bent at the end to form a hook. The earth lead is then attached to the end of whichever string you happen to "catch" and simply drawn through.—G. W. ARNOLD (Ilford).

A Gas-Saving Heater

MANY wireless constructors use a gas ring for heating a soldering iron, which is, of course, a very expensive method as the gas from three parts of the ring is wasted. Bearing this in mind, I constructed the heater shown in the accompanying sketch, and which has been in use for a full day, burning only twopennyworth of gas. In a piece of brass tubing four holes are drilled, one for the burner which

is soldered over it, and two for the four which are soldered in place. The ends of the tube were originally the brass end caps of an old resistor. The stand is made with 1/4 in. wire, and it will be seen that this forms a convenient holder for one or two irons of different size.—H. SCHOLES (Rochdale).

Setting a Slow-motion Drive

FOR overcoming the difficulty of accurately setting a normal slow-motion drive, used for band setting, to a pre-determined value, the following dodge will be found useful.

A number of fine holes are drilled with a pin drill around the outside of the scale, and a small sprig or panel pin which is a good fit has its head soldered to a short length of bare copper flex, as shown.

The holes are so arranged that the distance moved by the cursor between them covers a slightly greater band width than the band-spread condenser. Each hole is then numbered, and to set the condenser to a given setting, it is only necessary to insert the pin in the appropriate hole and turn the cursor until it comes to a stop against the pin. Of course, the pin must always be inserted on the same side of the cursor.—J. D. MORRIS (Stockport).

Experimental Valveholders

WHEN trying out experimental circuits, much time may be saved, and a better layout obtained, if the valves are used without the usual valveholders. By leaving the valves in their packing boxes, upside down, connection to the valve legs may be carried out by means of flexible leads fitted at the end with sockets. Quick changes and mobility are the main features of this idea.—G. S. (Hendon).

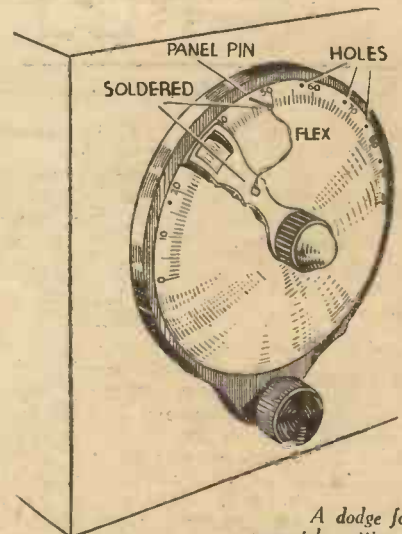

A dodge for accurately setting a slow-motion drive.

NEWNES' TELEVISION AND SHORT-WAVE HANDBOOK

2nd Edition

By F. J. CAMM.

Price 3/6 or 3/10 by post from the Publishing Dept., Geo. Newnes, Ltd., 8-11, Southampton St., Strand, London, W.C.2.

Philips All-Wave Superhet

A Review of the A.C. Model 797A

THIS is one of the new season's designs produced by Messrs. Philips, and it incorporates some extremely novel features.

The external appearance is extremely neat and handsome, a walnut cabinet being employed, and the general layout of the speaker opening, tuning dial, and controls producing a design which is most satisfying. Apart from the two dual-purpose control knobs, the main point of interest about the external appearance of the receiver is the tuning dial. This is known as the Adaptovisor dial, and in the illustration below it will be seen that this is set at an angle, whilst it is also made in the form of a shallow curve. It is hinged at the lower edge and may be raised to an almost vertical position, thus enabling the receiver to be placed in practically any position and yet still providing the operator with an easily-viewed scale. The large rectangular area is occupied by the three tuning scales—medium and long-wave and short-wave—and station names are engraved in the central portion. Small cut-away areas show the exact tuning position, which is identified when the vertical pointer which traverses the scale is brought into these areas. The drive is of the double-acting type, but is controlled by a single knob. When this is turned to a certain position the drive is direct and the pointer moves across the scale at a fair speed. If, however, the direction of rotation of the control is reversed, a much smaller movement is obtained, due to the action of a reduction gear, but, after a short movement, the main drive again picks up and the pointer moves quickly again. This device was found to act in a most useful manner, especially when it was desired to make rapid changes from one station to another.

The Circuit

The circuit comprises the standard superhet arrangement, with band-pass input to the frequency-changer. A single intermediate-frequency stage is employed and this feeds a double-diode-triode which is resistance-capacity coupled to a pentode-output valve. Valve rectification is employed in the mains section. Two features are of importance in this circuit. Firstly, the wave-change switch cuts out the band-pass tuner when turned to short waves, and at the same time the circuit is adjusted so that the oscillator frequency is slightly lower than the station frequency. Secondly, the output circuit is tapped and a portion of the signal is fed back into the triode portion of the D.D.T. valve, an arrangement which is claimed to give improved reproduction and freedom from distortion. A variable-selectivity control is fitted, and operates by varying the coupling in the first I.F. transformer.

The Controls

The controls, although four in number, are carried out by means of two mountings, the left-hand control effecting variation of tone by means of the larger portion, and volume and muting by means of the smaller portion. The latter both rotates and pushes in against a return spring. When turned, volume is controlled in the ordinary manner, but when pushed in the circuit is muted, or silenced, so that it may be kept in this position whilst the right hand rotates

the station-selector control. The spring is quite weak and only slight pressure is required, as a result of which the makers have termed this a "Finger-tip Silencer." The

moment pressure is removed, the control knob returns to its normal position, and this may be at any point of its rotation from minimum to maximum volume. This control is not arranged as in some receivers, and complete silence is not obtained when the knob is pushed right home. The volume which remains, however, is just sufficient to assist in identifying a station.

The right-hand control is divided so that the larger knob switches the receiver on or off and changes from one waveband to another. The smaller knob on this side is the usual tuning control. At the right of the tuning dial is a curved and coloured scale divided into sections marked with the various wavebands, and as the wave-change control is turned a light travels behind the tuning indicator and shows instantly to what band the receiver is set. On the left of the tuning dial is a curved visual-tuning indicator in the form of a small pointer travelling behind a scale. This is a standard meter-type indicator, and the pointer shows the tuning setting as evidenced by the anode current of the I.F. valve. A readable deflection is obtained even on weak stations.

Test Report

The receiver was tested out on our usual aerials, and in order to obtain a more accurate idea of its sensitivity the mains aerial plug on the receiver was employed in place of standard outside aerials.

On the medium and long-wave bands the sensitivity is of a very high order, and a particular point which was noticed was the entire absence of background noises and whistles. Even with the mains aerial several good short-wave broadcasting stations were heard, and the usual amateurs and commercial code stations were easily obtained. All of the controls were found to function in a most satisfactory manner, and freedom from backlash, noise, and erratic action characterised every operation. The quality of reproduction reaches a high standard, and the receiver is in every way a most satisfactory production. The price is 14½ guineas.

In this illustration of the Philips receiver the tuning panel is lowered.



SPECIFICATION

RECEIVER: Model 797A All-Wave A.C. Superhet.

CIRCUIT: Superhet. Octode frequency-changer, pentode I.F. amplifier, double-diode-triode and pentode output stage. Valve rectification, band-pass input circuit, resistance-capacity I.F. coupling. Tuning divided into three separate wavebands—16.7 to 51, 185 to 590, and 726 to 2,000 metres. Provision for external loud-speaker and pick-up. Variable selectivity control, by varying coupling in first I.F. transformer. L.F. tone compensation due to feed-back from output stage to first L.F. circuit. Visual tuning indicator in I.F. anode circuit.

VALVE COMBINATION: Octode frequency-changer, Mullard F.C.4; Pentode I.F. amplifier, Mullard VP4B; Double-diode-triode, Mullard TDD4; Pentode-output valve, Mullard PenA4; Valve rectifier, Philips 182L.

CONTROLS: Two combination controls, providing tuning, on/off, wave-change, tone, volume and silencing.

PRICE: 14½ guineas.

MAKERS: Philips Lamps, Ltd., 145, Charing Cross Road, London, W.C.2.

THE WIRELESS CONSTRUCTOR'S ENCYCLOPÆDIA

By F. J. CAMM
(Editor of "Practical and Amateur Wireless")

4th Edition 5/- net
Wireless Construction. Terms and Definitions explained and illustrated in concise, clear language.

From all Booksellers, or by post 5/6 from George Newnes, Ltd., 8-11, Southampton Street, Strand, London, W.C.2.

Be your own Service Engineer



The D.C. Avometer
Current
 0-6 m/amps
 0-30 "
 0-120 "
Voltage
 0-6 volts
 0-12 volts
 0-120 volts
 0-240 volts
 0-300 volts
 0-600 volts
Resistance
 0-10,000 ohms
 0-60,000 ohms
 0-1,200,000 "
 0-3 megohms



The UNIVERSAL AVOMINOR £5

Can you trace the faults that cause noise, distortion or breakdown? Yes! —if you have an Avometer! It is easy to track down trouble with either of these combination meters, for they cover all test measurements of current, voltage and resistance. And the important point is that they are high-precision meters — made by the makers of the famous Avometer. With either model you can quickly diagnose all faults in valves, circuits, components, batteries, power units, etc.

Both models of the Avometer are complete with leads, testing prods, crocodile clips, and Instruction Booklet.

AT ALL GOOD DEALERS

On Deferred Terms if desired

WRITE FOR DESCRIPTIVE PAMPHLETS

BRITISH MADE

The

AVOMINOR

EVERY TEST — with ACCURACY

The AUTOMATIC COIL WINDER & ELECTRICAL EQUIPMENT Co. Ltd.
 Winder House, Douglas Street, London, S.W.1. Telephone: Victoria 3404-7

**'I'm trying a
Drydex this time.
Everyone tells
me they last so
much longer.'**



Drydex

DRY BATTERIES FOR RADIO

'Still keep going when the rest have stopped'

DX154

Obtainable from all reputable dealers and Exide Service Stations.

EXIDE BATTERIES, Exide Works, Clifton Junction, near Manchester. Also at London, Manchester, Birmingham, Bristol, Glasgow, Dublin and Belfast.

Give your old battery set
1937 ALL-MAINS PERFORMANCE

Why buy a new mains receiver when there are unsuspected powers of performance still hidden away in your trusty old battery set—unthought-of power, wider range and truer tone—all waiting to be released by an "ATLAS" Unit?

An "ATLAS" Unit abolishes batteries, gives you Power from the Mains and 1937 performance for less than a shilling a year.

Models for D.C. and A.C. from **32'6d.** cash or **5'-** deposit. Ask your dealer for full details or send coupon below



ALL MAINS UNIT K12/25

57'6

CASH. Yours for 5' deposit.

Tappings 60/30 v. (min. & max.), 50/30 v. (min., med. & max.), 120/150 v. Outputs 12 mA or 25 mA at 120/150 v. L.T. Trickle Charger 2 v. at 0.5 A.

POST COUPON NOW

Messrs. H. CLARKE & CO. (M/cr.), LTD., ATLAS WORKS, PATRICROFT, MANCHESTER.

Please send me FREE Folder telling me how to give my battery set 1937 All-Mains performance.

Name

Address

AW/1

BIRDMEN . .
through the Ages



Demonstration of the glider designed by Otto Lilienthal, gliding pioneer, who lost his life in one of his experiments.

THROUGHOUT the ages man has tried to fly like a bird. Only one has so far achieved real success—Clem Sohn, who recently evolved a new technique. The attempts of the earlier Birdmen make thrilling reading and are described in this month's PRACTICAL MECHANICS. The article includes some stirring photographs.

Other special contents of the October PRACTICAL MECHANICS include :

- A Midget 4-Wheeled Car with 2½ h.p. engine.
- Microphones Made at Home.
- How the Pneumatic Road Drill Works.
- Making a Rowing Machine or Trainer.
- Television Arrives.

THE OCTOBER

PRACTICAL MECHANICS

Of all Newsagents and Bookstalls, or by post 7½d. from the Publisher, George Newnes, Ltd., 8-11, Southampton Street, Strand, London, W.C.2.





On Your Wavelength

BY THERMION

The Baseboard Controversy

FORTY-ELEVEN

My Reminiscences

ONE or two readers have been kind enough to suggest that I should write my reminiscences, which has put an idea in my head. They think that I should be able to write an entertaining volume and could incorporate for permanent record my views on miscellaneous topics. I do not think that many people would be interested in a book from my pen, and suggest that the Editor could write a better one. After all, he meets everybody, knows the secrets of firms and personalities in many industries, and has had an interesting career. Who am I that I should write my reminiscences? I am only a contributor, and I draw my encouragement from Editors. They are the most interesting and most enlightened class in Fleet Street. The trouble is that they are far too busy producing papers to write reminiscences.

A Generous Offer

MR. T. E. LOWE of 28, Allenby Road, Cadishead, Manchester, tells me that he has a pile of radio magazines including PRACTICAL AND AMATEUR WIRELESS and the *Wireless Magazine*. He wants to dispose of them, and if any reader would like to have them he should get into touch with Mr. Lowe. In the course of an interesting letter Mr. Lowe says that he is anxious to contact an amateur interested in short waves and residing within seven miles of Cadishead, as he has been asked by an ultra-short ham friend to try and arrange a schedule between him (he is in the W9 district), and a G ham around his locality. It is very generous of Mr. Lowe to make the offer, and in return I hope he gets into touch with the amateur of his heart, for one good turn deserves another, whether you are the lucky recipient or not.

readers have written to me expressing either agreement or disagreement with my remarks about baseboards versus chassis. One reader sent me a tirade saying that unless I published it this journal would go down in his estimation. I refuse to be intimidated in this way, for it indicates the selfish outlook of which I complained when I wrote of a reader who felt that we ought to scrap chassis construction and adopt the baseboard system because he happened to have an old cabinet. Regular readers are well aware that I am unafraid to publish letters expressing the opposite point of view. It is poor tactics to write to me and end your letters by some such phrase as "I dare you to publish this letter," or "You will go down in my estimation unless you publish this letter," I ignore such letters, for if a view point is worth expressing it will invite expression without the goad of a threat. When threats are made I am inclined to quote Shakespeare and say, "Me think'st thou do'st protest too much," and a man who ends his letter with some silly Latin tag such as "Verb sap" is an adjectival ass. There is a pun in that sentence if you care to look for it. Regarding baseboards it does not matter two hoots to me which system is used, and my remarks were confined to an analysis of popular demand as gauged by readers' desires. I have no doubt that the Editor will bow to popular demand if there is a large outcry for baseboards. He is even likely to test the matter by designing a set on a baseboard. One reader, L. A. L., of West Ewell, says that a great number of amateurs are not too affluent. Even those who are must temper their enthusiasm by a sense of proportion. He must compare the price and the merits of a commercial receiver against the

claims made for, and the price of, a kit of parts for a home-constructed receiver. This reader thinks that most amateurs are confined to straight sets as they have cabinets, speakers, and power packs as part of their fixtures, and what he wants is a set which will make use of most of these parts. He likes the baseboard because he can get at each part, and can always close the lid if he wants the set to look tidy. All of which merely reiterates what has been said before.

Television Starts

THE television programmes are now of daily occurrence. They insinuated themselves into the B.B.C. programmes without the usual fanfare, which seems to indicate a nervousness on the part of the authorities. I do not know how many people are looking in; probably less than a hundred, and these will be mostly those in charge of the experimental departments of manufacturers. The television service proper will commence in the early days of November, and something less than one thousand sets will have been delivered by that time. Home-constructors must get busy, and so must component manufacturers, for very few of them are stocking what I would call the key components necessary for the power pack and the time base. I will end this paragraph cryptically by asking you to watch this journal

After Two Years

AND so, inconspicuously, we see the dawn of a new industry and a new science. It is true that its birth reveals a sickly infant muling and puking in the arms of a nurse who loathes the unwanted child. Television has been handled in a scandalous way in this country. Because the television committee could not make up its mind which of two systems was the better it blandly advised that television receivers must

be capable of reception on both systems. The poor purchaser is therefore left to buy a receiver at an exorbitant price only to find perhaps after a year that only a half of it is necessary. The race is to the swift, and whichever company happened to be ready, should have been given a licence for a year. As it has turned out, one was ready and the other was not, and on the dog-in-the-manger principle the B.B.C. could not do anything until both were ready. Science and invention in this country has always been discouraged in that way. We have a lot to learn from Germany in this respect.

Decline of Crooning

I AM pleased to be able to report that there has been a great decline in the amount of crooning broadcast during the last three months. This is probably due to the campaign I launched against it and which has been taken up with gusto by fellow scribes who serve other papers. Fortunately there has been no swing of the pendulum the other way to the balladic drawing-room tosh pumped out in the early part of the present century. People do not hold drawing-room parties on the lines as formerly. The hostess in those days anxious to impress her guests, would invite a famous composer or vocalist to the party. You know the sort of vocalist I mean—the sort of man who keeps his eyes glued to a sheet of music to impress the audience with his ability to read music. The fact is that he had learned it off by heart beforehand. Still, it looked very clever when he was asked to sing to nonchalantly pick up a piece of music from the piano, study it for a second or two, as though he had never seen it before, and proceed to sing it. The chuck-a-chest type of vocalist is as distasteful to me as a crooner. The latter are as bad as the male creatures who form the chorus in a third-rate touring musical show. We must thank radio for ridding us of these abhorrent creatures. What will crooners do next? Readers tell me that they have to live. I suggest that they might try a spot of work for a change. Such will, of course, cause their voices to break.

The Six Days' Race

A FRIEND who is on the staff of our contemporary, *The Cyclist*, persuaded me to see the Six Days' Cycle Race. It was the first event of this type which I had witnessed and I found it a most exciting affair. The public address system, however, left a lot to be



Notes from the Test Bench

Mains Transformer Windings

MAINS transformers are designed to provide a certain output voltage for a definite current consumption. For example, the L.T. windings may be rated 4 volts at 5 amps., and 4 volts at 2.5 amps. This indicates that a voltage of 4 should be available from each winding when the current consumption is 5 amps. and 2.5 amps. respectively. Currents in excess of these values should not be taken from the windings otherwise overloading and consequent overheating is to be expected. On the other hand, if the current is lower than the rated value the output voltage will be greater than 4 volts and the valves may therefore be damaged due to excessive heater voltage.

Correcting Heater Voltage

THIS is to be particularly avoided, of course. If only three 4-volt 1 amp. valves are fed from the 5-amp. winding the voltage will rise to 4½ volts in some transformers, and therefore the valves will burn out quicker than with the correct voltage in use, and distortion is also likely to result. The current can be increased to the required value of 5 amps. by connecting 2 ohms resistance across the winding, but it is often difficult to obtain a resistance of the exact value required. There is a simpler method of providing the correct load; an old valve with heater intact can be connected across the heater circuit.

Energised Speaker in A.C./D.C. Set

THE field winding of a moving-coil speaker can very easily be energised in an A.C. set by connecting it in the common H.T. + lead in place of the smoothing choke. When this method of connection is used a mains transformer and rectifier capable of supplying the required H.T. voltage plus the voltage dropped across the field winding must be used—the normal voltage required is 350 volts. In A.C./D.C. sets the supply voltage is generally lower than 250 volts, however, and therefore this method of connection cannot satisfactorily be employed. The speaker field winding must therefore be energised direct from the mains or it may be connected across the output circuit of the rectifier.

desired. The announcers may have known all about cycle sport, and the combination of their poor declamation, bad articulation, enunciation, poor elocution, and 'woofy' amplification caused me a little worry in trying to follow the events and to associate the statements with the movements on the track.

Brooklands Mountain Race Broadcast

I UNDERSTAND that F. J. Findon will again be in charge of the running commentary in the National programme on October 17th on the Brooklands Mountain Race. This gruelling race is staged over a short circuit, including the famous Brooklands test hill. Mr. Findon faces a microphone placed by the turn at the foot of the hill, from which vantage point he has the cars in view all the way round the track and is able to describe their turns round each sharp bend. From this point he can also see right down the straight and ultimately view the sprint to the finishing point. The background of this broadcast is extremely interesting, as listeners who are motoring enthusiasts can tell from the whirring of the exhaust the revs. of each competitor. Many listeners are familiar with the cars themselves, but for those who are not, Mr. Findon's intimate knowledge makes this annual sporting championship a broadcast of much interest.

Those Sunday Programmes

CHANGES in the construction and scope of the Sunday programmes, the introduction of more variety in day-time broadcasts, and a more attractive arrangement of evening programmes during the coming winter were referred to by Mr. C. Graves, Programme Controller of the B.B.C., broadcasting the other evening in the National programme.

Early this summer the B.B.C. began a revision of their programme arrangements. And in the light of experience, and evidence that had come from outside sources, conclusions were reached as to changes thought desirable.

Some of you may have been led to think that the decisions are to be, or ought to be, revolutionary. They are not, for you must remember that during the past years the B.B.C. has been trying to construct their programmes in such a way as to meet a large number of requirements, and a number of these have been met. They do not want to disturb arrangements that are known to be satisfactory just for the sake of change. All of which indicates that we may, or may not, get the mixture as before, or a distinction without a difference.

Practical Television

October 10th, 1936. Vol. 3. No. 19.

AN IMPORTANT ANNOUNCEMENT

NOW that the television programmes are in regular operation every listener is anxious to take some steps towards building apparatus suitable for the reception of either the sound or vision, or both. We have already described one Television Sound receiver, and in this issue will be found some interesting details and circuits for other sound receivers (see page 111). Whilst the experimental transmissions were in progress we carried out a number of experiments with a view to arriving at a suitable circuit which could be used for the vision portion of the transmission and many interesting facts were disclosed.

We have always led the way in design in regard to the standard broadcast receiver for the home-constructor, and we are now happy to state that we have produced a really practical vision receiver which employs the modern cathode-ray tube for the reception of the high-definition transmissions. Naturally a receiver of this nature must, at the present time, be of a very comprehensive nature. There are many points which require careful attention, and in the design of the time base alone, much experimental work had to be carried out in order to arrive finally at an arrangement which would enable the average handyman to build up a circuit which could be changed instantly from the Baird system to the interlaced arrangement which is employed for the Marconi-E.M.I. system.

Where the Constructor Scores

There have been many statements made regarding the suitability of the television equipment for home-construction, but it should be pointed out here that in this type of apparatus the home-constructor is in a very favourable position, especially in view of the large number of individual adjustments which have to be made. The initial setting up of the apparatus is not so difficult as is sometimes pointed out. On the contrary, it is comparatively simple, and is quite definitely of a very interesting nature. In the home-constructed receiver every provision may be made for subsequent modifi-

cation as the art progresses and for the adjustment of each individual portion of the receiver.

Criticisms regarding danger are also out of place. It is quite true that very high voltages are employed with the present cathode-ray tubes, but the current flowing at these points is very low. Furthermore, with the realisation that these high voltages are present every user will naturally take the simple precaution of switching off the mains supply before any internal adjustment is made. Special components are now on sale for the inter-connection of various units, and for the protection of the user, and

upon to provide fool-proof working under all normal conditions. Unit construction has naturally been adopted, both to simplify construction and to enable the apparatus to be disposed in a more or less standard radiogram cabinet, whilst permitting of a convenient mounting for the large cathode-ray tube which is employed. A full-size black-and-white picture is obtained, and in view of the comprehensive nature of the apparatus it will naturally have to be described unit by unit. The illustration on this page shows a Television Mains Unit which will be described next week, and the circuit of the time base and further details will be given in forthcoming issues. Make sure you are one of the first in the field, and take advantage of the interesting early television transmissions, and order your copies now!

A NOVEL BROADCAST

AT the request of the British Broadcasting Corporation, the Society of Motor Manufacturers and Traders

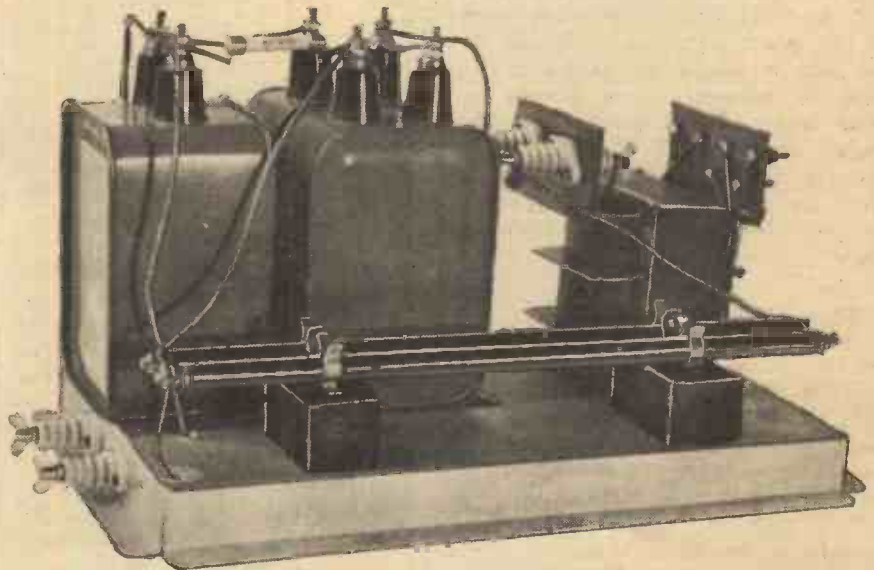

A Television Mains Unit, which will be described next week.

some of these have already been mentioned in our pages. The new components will be dealt with in our Facts and Figures section as soon as they come to hand.

Our New Receiver

With regard to the receiver which we have designed, this has been submitted to one of the largest firms in the industry whose pioneer work in the field of television is now well known. We have their confirmation that the arrangement is ideal for the home-constructor and for home use. The time base is of simple but efficient design, and may be relied

Limited, have arranged for the provision of a parade of twenty British private cars to be included in one of the first experimental television programmes to take place on October 9th at Alexandra Palace at 3 o'clock.

Each car will be driven in front of the television "camera," and will be described by the commentator for a period of approximately 1½ minutes, the whole programme taking in the region of half an hour.

It is hoped to arrange a similar television feature during the period of the Motor Exhibition.

TELEVISION NOTES

U.S.A. Regulations

ATENTION has been drawn in these pages during the last few weeks to the evidence given before the Federal Communications Commission of the U.S.A. in so far as it affected the development of television. The outcome of this has been the preparation of regulations which must be observed during the final experimental stages of television. Technical rules specifying the type of equipment have been drawn up, while a very strong effort is being made to obtain the full co-ordination of the companies on the question of standardisation. Added receiver expense has been brought about in this country owing to the employment of two quite different standards of transmission at the Alexandra Palace. This state of affairs will sort itself out eventually, but in the meantime each television set sold must be capable of switching over from one system to another. This has complicated the equipment, and quite naturally added to the cost which must be borne by the purchaser. In the U.S.A. every effort is being made to avoid this trouble, and as it is anticipated that at least another year, perhaps two, will elapse before any public service is scheduled, no doubt some form of equitable agreement will be arrived at in the interim period. Other F.C.C. regulations deal with the use of present experimental television stations for sponsored programmes, and state that any announcement must be confined to a single statement of the sponsor's name, or, alternatively, a televising of the trademark or product which is being advertised. It is hoped that these regulations will ensure that development will proceed along sound technical grounds without any exploitation beyond the capabilities of the service.

Make-up Troubles

A measure of difficulty is still being experienced in finding the most suitable type of make-up at Alexandra Palace which will enable the artists and announcers to "look their best" on the receiving screens. It was very apparent during the course of the transmissions to Radiolympia that the faces of the lady artists especially had certain features over-emphasised, while others were almost missing. Furthermore, tests with Miss Elizabeth Cowell (Miss Jasmine Bligh is still recuperating after her operation for appendicitis) have shown her with a black eye, a dirty face, and on one occasion with hardly any eyes at all. A beauty expert is now engaged in evolving the perfect make-up for each system—that is, the Emitron of E.M.I.'s, and the spotlight and intermediate film camera of Bairds'. It must not be inferred from this that an individual cannot be televised without any form of make-up. The addition of make-up, just as in the case of the stage and film studio, however, removes some of the peculiar effects noticed as a result of the colour response of the photo-electric devices used in the television scanners.

Static or Magnetic

The methods which have been proposed for controlling the movement of the beam of electrons in a cathode-ray tube, coupled with focusing and modulating devices, have been legion, but the release of informa-

tion concerning the present-day type of tubes used in television receivers seems to show that there are now two main schemes. The first is electrostatic, and this is apparently the most popular. For this to operate the electrode system becomes rather complicated. First of all, we have the cathode, whose resultant beam of electrons is focused by a combination of three anodes consisting of small metal discs with a centre aperture. To these are applied the voltages for making the spot of light on the screen of correct focus through the medium of established electron optic principles. Added to this are the two pairs of metal deflector plates set at right angles to one another, so that by the application of saw-tooth voltages of the correct frequency a raster is built

anode (for electron acceleration towards the screen) and modulation electrode. Scanning is effected by mounting air-cored line and iron-cored frame coils external to the tube. Focusing is effected by passing a direct current through a solenoidal coil which surrounds the neck of the tube. The adjustment of the raster on the screen is thereby simplified, while the cap connections are limited to a total of four. The relative performances of these two types of tubes will be studied with great interest now that the television service is in operation, since it is the final result shown on the picture reproducer which will settle the standard of each receiving set.

Keeping a Record

On the occasion of a second Press visit to Alexandra Palace a few days ago the Baird Co's. intermediate film-equipment was shown in operation for the first time at the station. According to reports the results obtained were outstandingly good,

each member of the separate visiting parties being televised, so that after a lapse of only half a minute they were able to see themselves as a television picture on a standard type of receiver. With this apparatus it will be possible to televise shows or events at any time most convenient to the persons concerned, to be radiated subsequently as a television signal according to the programme needs of the television director. It should also help to solve partially the question of programme costs, for just as certain types of sound programmes are repeated so a recorded television programme will be available for similar needs

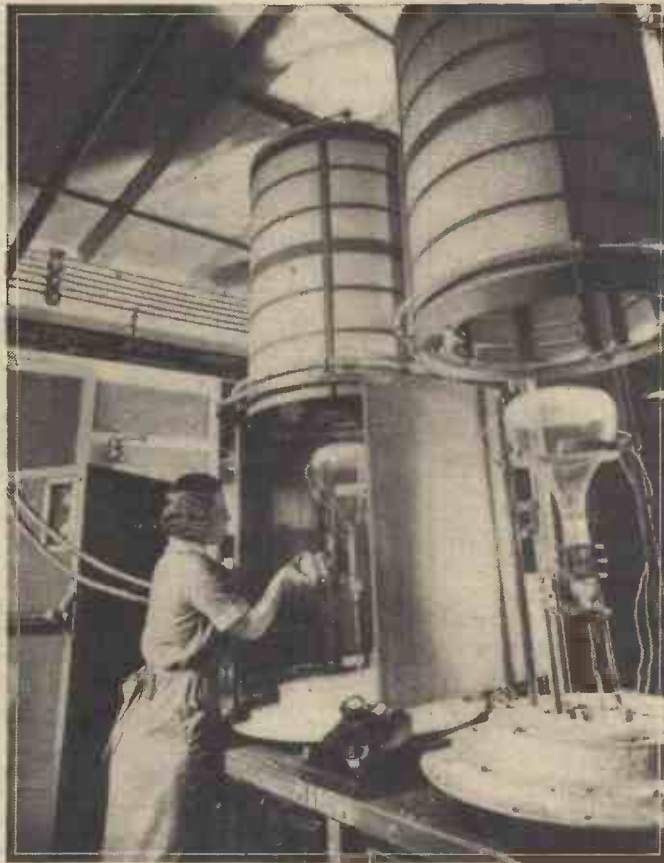

Exhausting a cathode-ray tube at the Osram G.E.C. Lamp Works.

up on the screen and repeated as a complete scan the correct number of times per second. Finally, there is the modulation electrode, whose function is to receive the video component of the radiated television signal and make this vary the intensity of the electron beam so that during its trace the requisite light and dark picture shades are built up to give the picture intelligence required. All the connections for these electrodes accommodated in the tube's glass neck are brought out to a plug which has to be carefully designed to withstand leakages and voltage breakdown. Design, assembly, and alignment have to be undertaken with scrupulous care, otherwise the tube's performance will be below standard. With the electro-magnetic types, however, many of these difficulties are overcome. The electrode assembly consists of a cathode,

and cost thereby saved.

Sheffield Tests

Amateur radio transmitters in Sheffield are conducting tests on ultra-short waves from a portable transmitter erected in a field near Lodge Moor Hospital. They are anxious to learn over what distances their telephony messages can be received. The district of Sheffield has a peculiar configuration of hills and dales, and if it is proposed to build an ultra-short-wave television station there, the work which the amateurs are now carrying out may prove of service to the authorities. It must be remembered, however, that an ultra-short-wave carrier modulated with the narrow frequency band required for speech has quite different range characteristics from the same carrier modulated with a video signal.

ABC of the Modern Receiver—3

NEXT to the aerial tuning circuit is the first valve—in the simple circuit under consideration, the high-frequency amplifier. As was briefly explained in the first article of this series, the purpose of this is to increase the voltage of the signals as received by the aerial system before they are passed to the detector. In order to understand how this amplification process operates it is necessary to understand the function of the simplest type of valve, which is the triode or three-electrode valve. This is not the type of valve actually employed

High-frequency Amplification is Explained this Week, Reference being Made to Triode, Screen-grid, H.F. Pentode, and Variable- μ Valves

or five to several hundred volts on the anode, according to the type of valve. It is the ratio between the grid and anode voltages required to produce any

terminal of the high-tension supply is connected to one side of the accumulator (theoretically it does not matter whether it is joined to the positive or negative side, although the latter is more usual).

Amplification Factor

First consider that the tuning circuit is not set to receive any signal, but that the batteries are connected due to the switch being on. Current flows from the accumulator through the filament, so causing it to become hot. Between the filament and the anode there is the voltage or potential of the high-tension supply, and this causes current to flow from the filament to the anode; in doing so it passes through the grid, which is mounted between the other two electrodes (see Fig. 2). Technically it can be stated that the current passing from the cathode or filament to the anode is in the form of a stream of electrons ("particles" of negative electricity), but it is sufficient merely to regard this as a stream of electrical current. The amount of current which can pass is governed primarily by the voltage or potential difference between the filament and anode, since the vacuum of the valve acts as a high resistance.

But it has been found, and is now widely known, that the current can be varied to a considerable extent by varying the voltage on the grid of the valve. Thus, if a battery were inserted between the coil and the grid in Fig. 1, so that the positive terminal were connected to the grid and the negative to the filament (through the tuning coil), the filament-to-anode current would be increased. On the other hand, if the battery were connected in the reverse manner the current would be reduced. This is not all, however, for a change of one volt in the grid voltage produces as much effect as a change anything from four

given change in anode current (from the H.T. supply) which determines the amplification factor of a particular valve. For example, if an increase of 30 volts H.T. were required to raise the anode current one milliamp, and if the same change could be produced by making the grid one volt more positive, the amplification factor of the valve would be 30. There are certain limiting conditions in this respect, but they need not be considered here. The main point to grasp is that the signal voltage can be amplified or increased by the valve.

Increased Signal Voltage

The fluctuating high-frequency voltage developed across the tuning circuit is applied to the grid, and this voltage is increased by the valve, appearing across the "load" in the anode circuit. The simple three-electrode valve, however, is not normally suitable for high-frequency

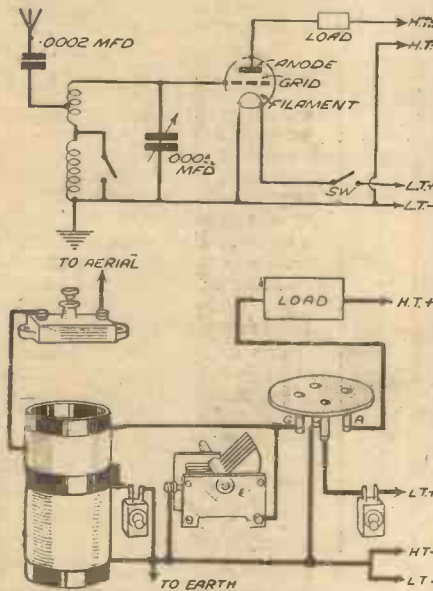

Fig. 1.—The simplest form of H.F. amplifier, using a three-electrode valve—which is now obsolete for this purpose, but which serves to illustrate the first principles.

in the H.F. stage of a present-day receiver, but all other types of valve are modifications or developments of it.

The Simple Valve

A three-electrode valve, as the name indicates, has three electrodes; these are the filament (or cathode), the grid, and the plate or anode. In the case of a valve designed for mains working the cathode contains a coil of resistance wire which acts as a heater, but in a battery valve the heater and cathode are combined in the filament—which glows when current is passed through it.

In following the operation of this simple valve, let us imagine its use after the tuning circuit, as shown in Fig. 1, for we can then easily follow the slight alterations which occur when using a screen-grid or H.F. pentode. It may be seen that the filament is joined to the accumulator, and also that one side of it is connected to the tuning circuit and to earth. The grid is joined to high-tension positive through what is simply shown as a "load"; in practice this is another tuning circuit. It should also be noticed that the negative

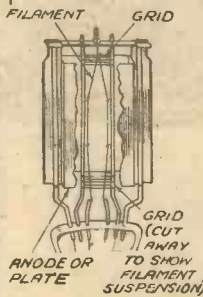

Fig. 2 (left).—This shows the relative positions of the filament grid and anode in a typical three-electrode valve.

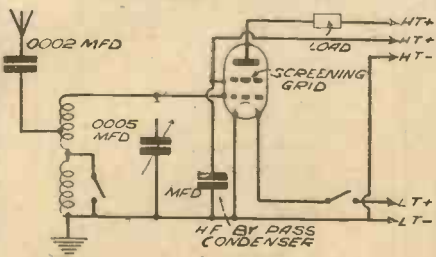

Fig. 3 (below).—This circuit is similar to that shown in Fig. 1, except that a screen-grid valve is used in place of the triode.

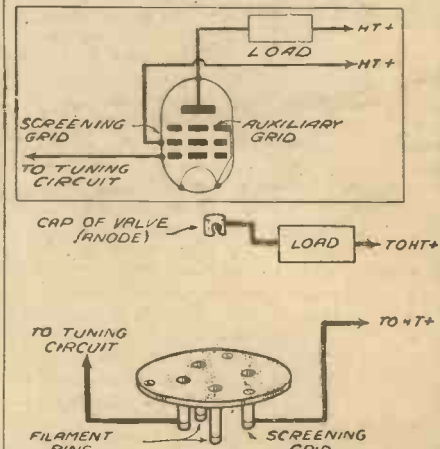

Fig. 4.—Connections for an H.F. Pentode, which is used in place of the S.G. valve in Fig. 3.

amplification, because of the condenser effect between the grid and the anode. Amplified high-frequency voltages appearing at the anode can leak back to the grid across the capacity of the "condenser" just mentioned. It will already be understood that a condenser does not offer any serious barrier to H.F. currents, because it can be placed between the aerial and the first coil!

It is here that we come to the screening-grid of the screen-grid valve. This is inserted between the ordinary (called control) grid and the anode, as shown in Fig. 3, and connected to a tapping on the H.T. supply, so that it is given a positive potential. As the name suggests, this additional grid acts as a screen, so preventing the other two electrodes from forming a fairly effective condenser. We can leave the matter at that, after explaining that the most suitable voltage to be applied to the screening grid is somewhat critical—so much so that at certain

(Continued on page 117)

OUR ADD-ON S

IN our issue of January 25th last we described a special H.F. and detector unit for use with our high-fidelity paraphase amplifier. This unit, while giving as nearly perfect reproduction from the local and more powerful Continental stations as it is possible to obtain, lacked the sensitivity and selectivity necessary to obtain good reception from many foreigners.

Since then, we have been experimenting with a superhet unit, our aim being to build a receiver which, while being as simple as possible, would reproduce the locals with more than usual quality and at the same time give the constructor a choice of at least fifty alternative programmes when conditions are at their best, and about twelve during daylight.

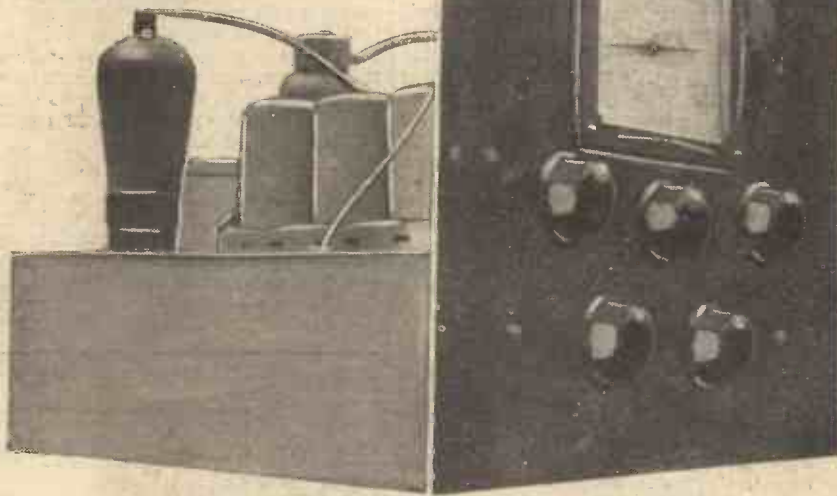

This view, together with that on our cover this week, shows the completed unit.

The results of our experiments are embodied in the unit presented here. In the "quality" position, reproduction from the locals is almost equal to that obtained with the "straight" unit previously described, while the "bag of stations" when the set is in its most selective state is indicated by the list given in the accompanying tables.

The complete circuit of the receiver unit is shown on the right, from which it will be seen that it employs only two valves and a Westector. One valve is the frequency changer, and the other the intermediate-frequency amplifier. The Westector is used not only as the second detector, but also to give simple A.V.C. controlling both the frequency changer and I.F. valves.

Frequency Changing

In order to obtain freedom from second channel interference which, of course, shows up as a series of whistles at various points of the dial, a band-pass pre-selector circuit has been employed. The coils used are Colvern G1 and G2 (iron-cored Ferrocart), which are very efficient, and have a common inductive coupling giving constant selectivity over the whole of both wavebands. It will be noticed that a separate aerial coupling is used on long waves and, should any change be made in the aerial system at any time, no re-ganging of the aerial circuit of the receiver will be necessary.

For the frequency changer a Ferranti VHT4 or a Cossor 41MPG may be used. These are heptode variable-mu oscillator modulator valves in which the oscillator and

detector portions operate separately, and can, therefore, be made more efficient.

A Special Unit for Use in Conjunction with the Paraphase Amplifier Described in the Issue of January 25th

Maintenance of oscillation throughout the wave range of the receiver is more readily and uniformly obtained, and the possibility of distortion and cross modulation on strong signals is obviated by their use.

Bias is applied to the valve by the fixed resistance R2 and also by A.V.C., and the detector and oscillator circuits are quite straightforward. The I.F. anode and screen are decoupled by resistances R9 and R10 and condensers C10 and C12. Maintenance of the correct voltage on the oscillator anode, and decoupling, is carried out by resistance R5 and R7 and condensers C7 and C12.

The oscillator is tuned by condenser C3 which has specially shaped vanes in order to cause this circuit to resonate at the correct frequency displacement of the I.F. circuit. The three condensers C1, C2 and C3 are in the form of a 3-gang condenser of which the third section is correctly designed for this purpose. Note that condenser C8 is automatically switched in to maintain correct tracking on the long waves.

I.F. Amplifier

The I.F. amplifier consists of a single variable-mu H.F. pentode coupled to the frequency changer by a 110 kc/s transformer, the secondary of which feeds the I.F. valve. The lower end of the tuned circuit is returned to the A.V.C. line, decoupling being provided by resistance R4 and condenser C9.

This I.F. transformer already embodies a variable coupling for selectivity control,

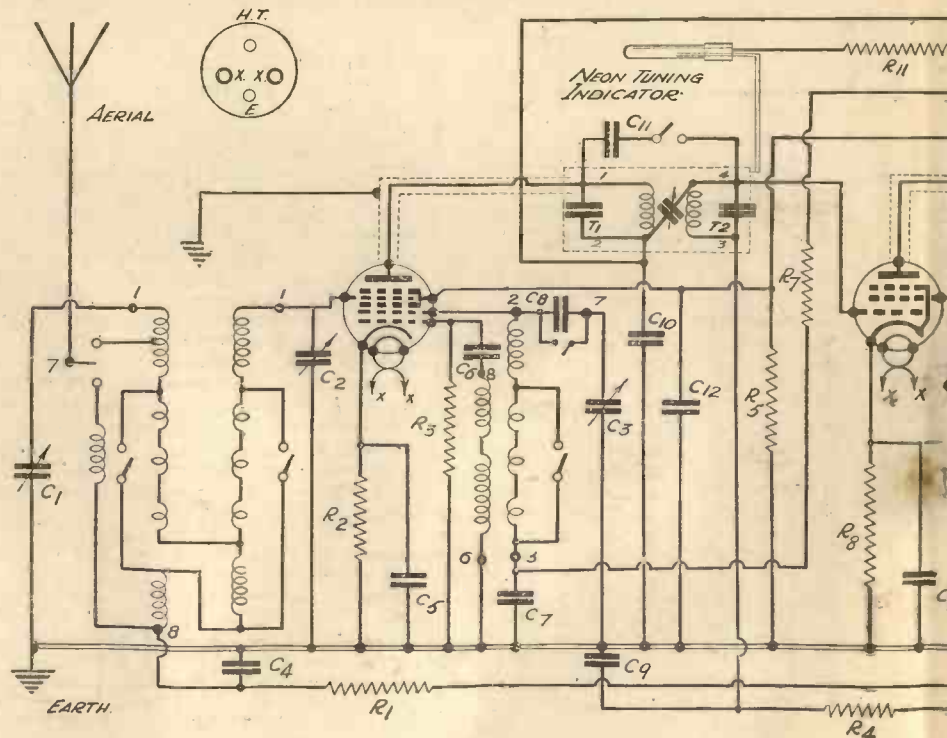

Theoretical Circuit of the Add-on Superhet Unit.

SUPERHET UNIT

With our High-fidelity Paraphase
of January 18th, 1936

and, by connecting another fixed condenser C11 in parallel with this small variable condenser, as shown in the diagram, we are able to obtain a much greater variation. This very simple method of obtaining variable selectivity by switching in a small condenser results in a great improvement in quality when receiving the local stations without going to the expense of special variable selectivity coils. Some readers may wonder why this fixed condenser is not kept permanently in circuit. The reason is that, were this done, reception of a number of foreign programmes would be marred by heterodyne whistles by virtue of the increased band-width and frequency response.

Second Detector

The use of a Westector as the second detector avoids overloading of this stage and provides almost linear detection. It also greatly simplifies the subsequent filtering of the I.F. component from the L.F. output, and A.V.C. is easily obtained.

The A.V.C. System

From the load resistance R6, the D.C. voltage available is used for A.V.C. by taking a connection back through simple resistance-capacity filters R1 and R4 and C4 and C9 to provide the control bias applied to the grid circuits of the valves.

In this manner a simple form of A.V.C. is obtained which involves merely the addition of two resistances

and two condensers forming the filters. The system is quite satisfactory, and it has not been considered necessary to employ the more elaborate arrangements required for delayed or amplified A.V.C. The constructor can, of course, easily add either of these systems if he desires to do so.

The L.F. output is also produced across resistance R6, and this is fed through condenser C15 via a radiogram switch to the

Construction

The construction of the unit is a simple matter, and can be carried out in the course of an evening. Wires should be kept as near as possible to the positions shown in the diagram, and particular care should be taken to keep heater wires as far as possible from grid and H.F. circuits. The yellow leads of the coil unit all carry H.F. currents and must be kept very short.

Before fixing the coil unit in position, drill holes in the chassis for the various leads to pass through. Also make the connections to the ganged condenser. These

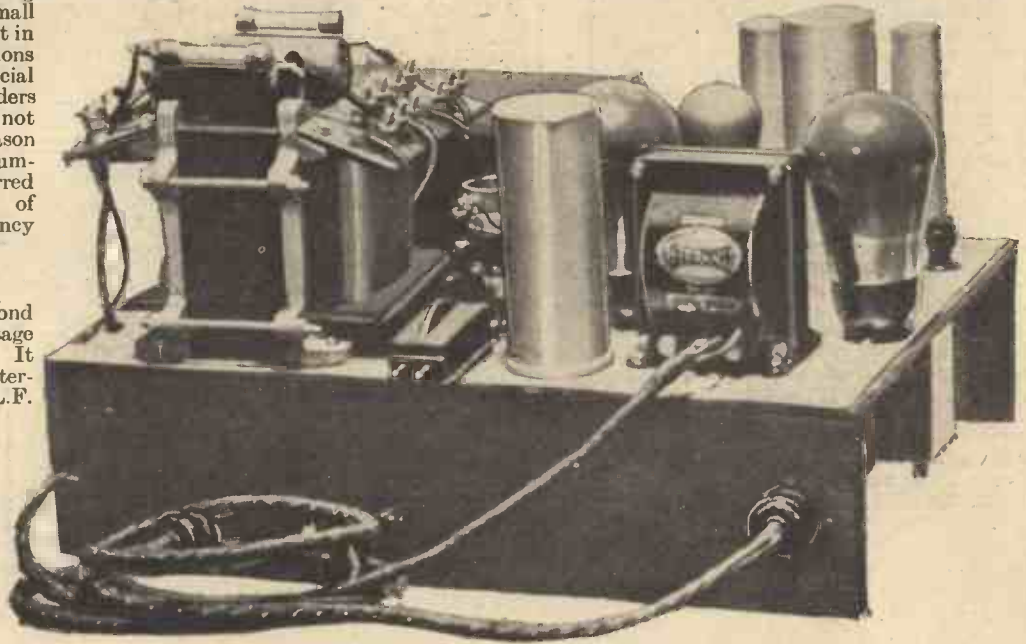

Here is the Paraphase Amplifier which was described in our issue dated January 18th last, and with which this Superhet unit is designed to work.

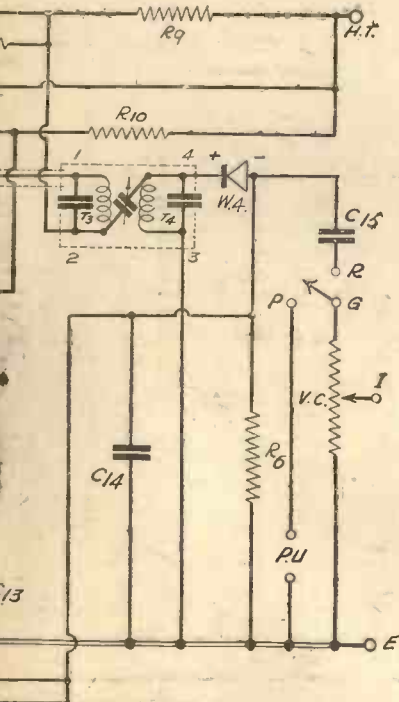

volume control V.C., which serves as the coupling to the amplifier.

For the constructor who considers the paraphase amplifier too ambitious for his requirements, the output from the volume control may be fed direct to a pentode-output valve. The total current would then be about 45mA, and an H.T.8 metal rectifier with an energised speaker of 2,500 ohms as the smoothing choke could be used. Enough has appeared in these pages to enable an intending constructor to add this output unit and power pack himself. The centre connection of the volume control should be taken direct to the grid of the pentode-output valve, while a condenser of .01 mfd. and a resistance of 10,000 ohms should be joined across the primary of the loud-speaker transformer in order to provide a measure of tone control.

A refinement, but one which is practically essential in order to tune a superhet correctly, is the visual-tuning indicator. This is a Cossor Neon Tuning Indicator. It is connected in the anode circuits of the frequency changer and I.F. valves, where it gives, in the form of a glow, spreading up the cathode (long electrode), a visual indication of the correct tuning point, this being indicated by the maximum height and intensity of the glow. Its inclusion, of course, also greatly simplifies ganging of the set, which, in the case of a superhet, is, without the use of some form of visual indication, a long and tedious procedure.

leads should be 1in. long only, and unless the work is carried out before fixing, trouble will follow. Turn the coil unit and condenser upside down, place them 1in. apart, and the connections can then be made quite easily. The two assemblies can then be placed on the chassis, the necessary wires threaded through their correct holes, and the units then bolted down.

A 4-pin valveholder is fixed on the left-hand side of the unit for connecting to the amplifier. The output lead from the unit to the input terminal of the amplifier must be screened and the screening earthed. A better plan, if hum is experienced, is to place the first two valves of the amplifier on the superhet chassis, and take two output leads to the amplifier. Since these leads will be carrying grid currents of opposite phase, hum will automatically be cancelled out.

When the wiring is finished and carefully checked, the valves should be inserted, and the unit connected to the amplifier. Connect aerial and earth and switch on. The valves will take a minute or two to warm up, during which period the glow in the neon tube will gradually diminish. One or two stations should be receivable at once, although perhaps weakly, and one at the lower end of the medium waves should be tuned in accurately, as indicated by maximum glow in the tuning indicator.

(Continued on next page)

OUR ADD-ON SUPERHET UNIT
(Continued from previous page)

Ganging

The set is now ready for trimming, and the I.F. transformers should be adjusted for maximum glow in the tuning indicator. Condenser C1 should not be in circuit, i.e. the set should be ganged in its most selective state.

Now adjust condensers C3, C2 and C1 in that order, also for maximum glow, at the same time turning the tuning condenser so that the dial reading for the station being received is correct, i.e. the condenser should be adjusted so that the London National programme, for example, is received at exactly 261 metres on the dial.

It will then be found that, by reason of the adjustment of C3 trimmer (i.e. the oscillator condenser), the frequency displacement of the I.F. transformers from the oscillator is not correct, i.e. it will be either more or less than 100 kc/s. The trimmers of the I.F. transformers should then be adjusted again for maximum glow.

When the ganging is correct, an attempt should be made to tune in as many stations as possible, when one or two whistles may be apparent. If ganging is correct, whistles should be heard at wavelengths of 455 metres and 323 metres, i.e. at a displacement of twice the intermediate frequency of 110 kc/s from London Regional and London National respectively. Heterodyne whistles, or second channel interference, can only be caused by a very powerful local, and where a constructor is situated at some distance from such a station, no whistles will be heard at all.

Should these whistles come in at other points of the dial, it shows that the intermediate frequency has been incorrectly tuned to some value other than 110 kc/s which will not suit the oscillator condenser, and hence it will not be possible to keep the H.F. circuits in tune over the whole of the waveband.

If these whistles are heard at higher points on the dial, the intermediate frequency is too high, and must be lowered by screwing down all the I.F. trimmers a little, and readjusting for maximum glow at this new setting.

WIRING DIAGRAMS OF OUR ADD-ON SUPERHET UNIT

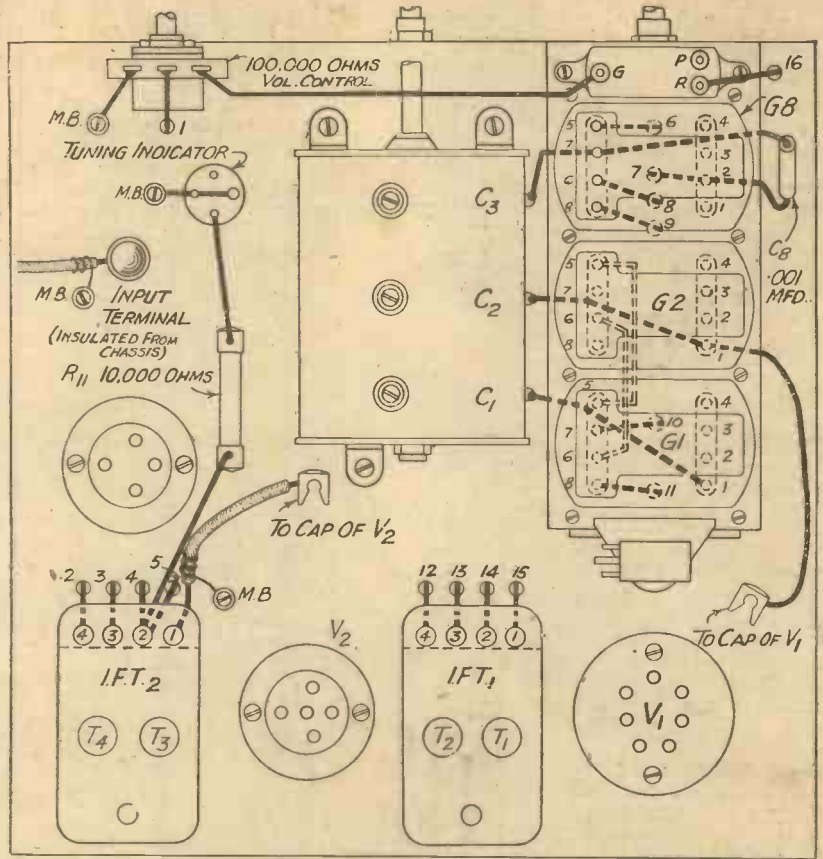

COMPONENTS REQUIRED FOR THE ADD-ON SUPERHET UNIT.

- 1 Colvern 3-gang coil assembly, types G1, 2 and 8.
- 2 Colvern F.C.110 I.F. Transformers,
- 1 J.B. Baby Superhet Gang, oscillator section in front, tracked 110 kc/s.
- 3 .05 mfd. condensers, T.M.C. type T23 (C4, C9 and C15)
- 4 .1 mfd. condensers, T.M.C. type T24 (C3, C10, C12 and C13).
- 1 .0002 mfd. condenser, Dubilier type 665 (C6).
- 2 .0001 mfd. condensers, Dubilier type 665 (C11 and C14).
- 1 1 mfd. condenser, Dubilier type BB (C7).
- 1 .001 mfd. condenser, T.M.C. type T10 (C8).
- 2 1 meg. resistances, 1/2-watt, Bulgin (R1 and R4).
- 1 300 ohm resistance, Dubilier 1 watt (R2).
- 2 50,000 ohm resistances, Dubilier 1 watt (R5 and R7).
- 1 50,000 ohm resistance, Bulgin 1/2-watt (R3).
- 1 100,000 ohm resistance, Bulgin 1/2-watt (R6).
- 1 500 ohm resistance, Dubilier 1 watt (R8).
- 1 20,000 ohm resistance, Dubilier 2-watt (R9).
- 1 20,000 ohm resistance, Dubilier 1-watt (R10).
- 1 10,000 ohm resistance, Dubilier 1-watt (R11).
- 1 7-pin valve holder, Belling-Lee type 1,138.
- 2 5-pin valve holders, Belling-Lee type 1,136/S.
- 1 100,000 ohm volume control, Dubilier type B.
- 1 W4 Westector (Westinghouse)
- 3 terminals (Aerial, Earth and plain), Bulgin type TL.
- 1 ft. screened sleeving, Bulgin.
- Connecting wire and sleeving.
- Mounting bracket for volume control (Bulgin Universal).
- 1 Cossor type 3,184 neon tuning indicator.
- 1 tuning indicator holder and mounting bracket (Bulgin VH25).
- 1 Push-pull switch with 6in. shaft and coupling (Bulgin).

- Valves—
- V1. Cossor 41MPG or Ferranti VHT4.
- V2. Cossor MVS/Pen. or Ferranti VPT4.

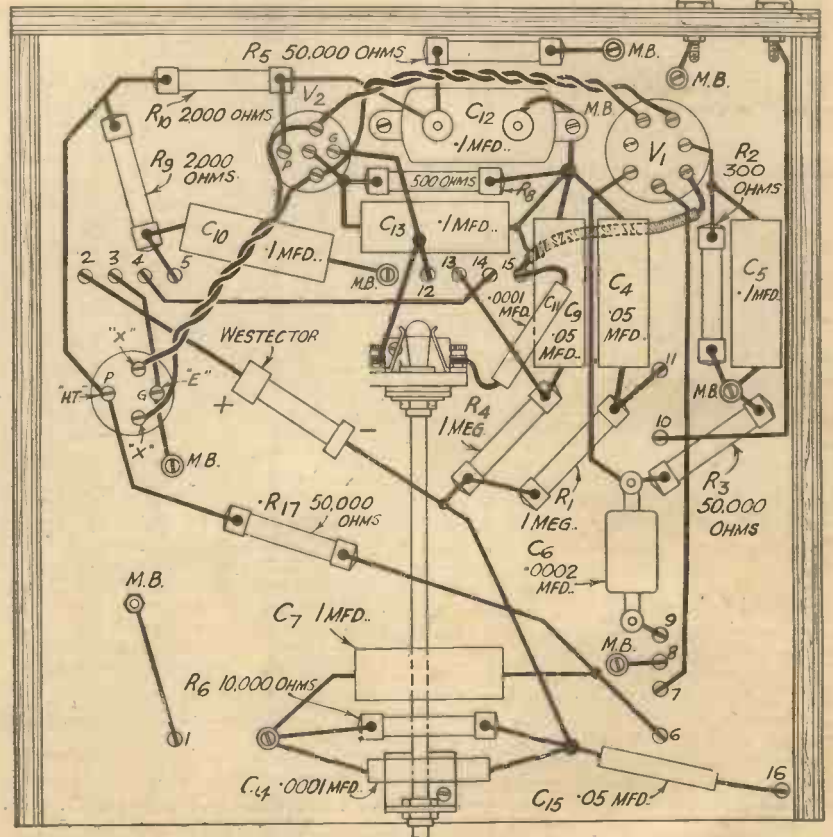



SHORT WAVE SECTION

SOME TELEVISION "SOUND" CIRCUITS

Main Details of Two Useful, Though Not Widely Employed, Simple Circuits for Ultra-short-wave Reception. By FRANK PRESTON

EVERY enthusiastic constructor is now looking round for simple ways and means of receiving, at least, the "sound" portion of the television transmissions. Details have already been given of one or two receivers and superhet converters for this purpose, but there are

this has been done in these pages before. For those who have forgotten the main outline, it will suffice to say that the detector valve is caused to oscillate continuously, although the oscillation is broken up by means of the so-called quench valve. The oscillation must be broken, for otherwise telephony would not be intelligible, being received merely as a "wavy whistle." The breaking up is carried out by

however, this background noise can be rendered practically inaudible on a signal of worth-while strength, so it is not very important. An advantage of super-regeneration, and one which is by no means insignificant, is that a receiver employing this circuit is far less critical than is usual, since there is no reaction adjustment in the ordinary sense, and also because the degree of selectivity is not exceptionally high. Nevertheless, it is high enough to permit of the proper separation of sound and vision programmes on the adjacent bands.

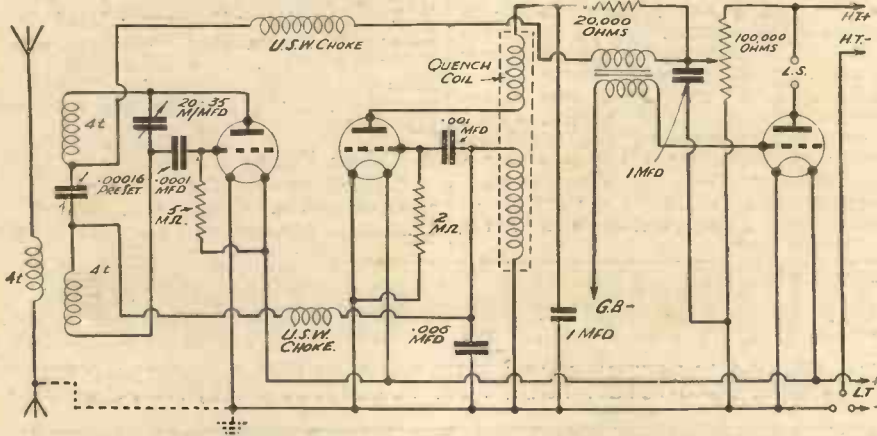

Fig. 1.—A simple and effective three valve super-regenerative circuit. Although a doublet aerial is indicated, an ordinary aerial can be used by adding an earth lead and using the connections shown by broken lines.

probably many readers who would prefer to have brief details of other general circuit arrangements with which they can experiment. It should be made quite clear that there is little difficulty in making a simple receiver for 7-metre "sound" reception, and that the constructor with reasonable experience of short-wave work need anticipate very little trouble. As to the reception of the "vision" portion of the transmissions, this is a different matter; it can be mentioned, however, that constructional details of a suitable receiver will be given in these pages in the near future.

The Super-regenerative Circuit

The receivers previously described have employed the straightforward Reinartz type of circuit which is well known to every constructor. This arrangement is certainly very good, but there are others which should be tried, if only because they provide additional interest; with care, they can generally be made to produce better results with fewer valves. Probably the best of these less-usual circuits is the super-regenerative, of which a circuit is given in Fig. 1. This is for a three-valver, consisting of detector, quench stage, and one L.F. It should not be necessary fully to explain the principles of super-regeneration, since

super-imposing upon the steady oscillation of variable frequency, another of approximately 20,000 cycles.

One objection to this system is that the second set of oscillations can be heard as a "hiss" when the set is tuned to a weak signal, or when it is off tune completely. With careful adjustment of H.T. voltage,

Quench Valve and Coils

Referring to Fig. 1, it will be seen that a form of Hartley circuit is used for the detector, the quench valve being connected in a normal regenerative circuit with series reaction. Detector reaction is controlled by the .00016-mfd. (max.) pre-set condenser, and also by the H.T. potentiometer. The pre-set, which should be mounted as close as possible to the coils, can be set to about two-thirds full capacity and then left alone. The coils may conveniently be of the Eddystone plug-in type, and should all be of four turns for the television wavelengths; their holders should be mounted end to end, the coupling being fixed. Tuning is by means of the condenser shown, as being of 20 to 35 mmfd., and this should be a good component and provided with a slow-motion drive and extension spindle. Care should be taken with the lay-out to ensure that this condenser is as near the coils as possible, so that the connecting leads are no more than 2in. or 3in. long.

As to the quench coil, this is now a standard component made by Eddystone and others. It consists of both tuning (tuned

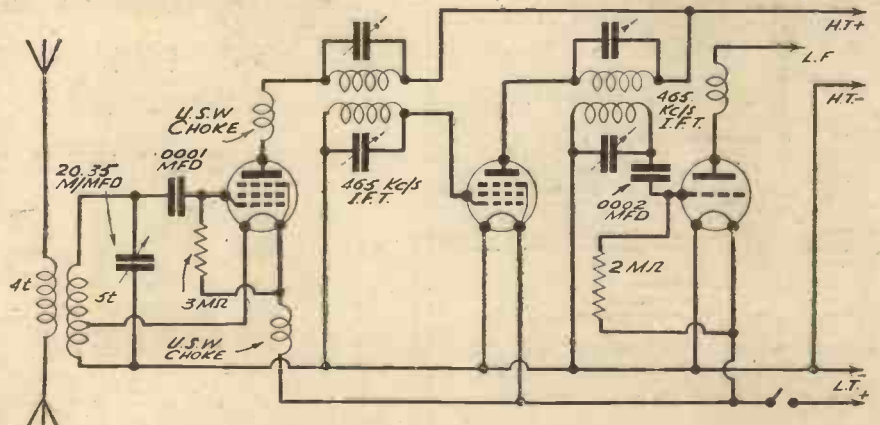

Fig. 2.—Skeleton circuit for an ultra-short-wave superhet using an electron-coupled autodyne frequency-changer. Connections are again shown for a doublet aerial, a four-turn coupling coil being used and mounted end to end with the five-turn tuning coil.

SHORT WAVE SECTION

(Continued from previous page)

by the .006-mfd. fixed condenser) and reaction coils mounted together on a paxolin tube. The low-frequency portion is absolutely straightforward, and does not differ from standard practice. A triode valve is shown, and this might be a Cossor type 220PA., the other two valves being of the HL type. If desired, a pentode could be used, but it is often found that a triode is less inclined to give trouble due to slight L.F. instability. Before the set can be used efficiently the pre-set reaction condenser must be adjusted. This is done by turning the H.T. potentiometer to about its midway position and reducing reaction-condenser capacity to zero by unscrewing the adjuster. After that the capacity of the pre-set can be increased until oscillation just commences. If this setting is carried out with the tuning condenser turned to its midway position, it should be found that a suitable degree of reaction can be maintained over the full range of the tuning condenser by manipulating the potentiometer. Although reaction adjustment is not critical, it will be found that the best compromise between sensitivity and background noise can be secured by occasionally varying the potentiometer setting.

Autodyne Oscillator

A superhet circuit is extremely satisfactory for ultra-short-wave reception—as evidenced by the fact that it is used by the majority of manufacturers who are providing complete television receivers. The main objection is that a greater number of valves is generally required, although a converter may be used along with the

broadcast set. A circuit for the autodyne oscillator, I.F. stage, and second detector of a good superhet is given in Fig. 2. It will be seen that the connections to the H.F. valve used as frequency changer are different from the usual, for there is no anode-circuit reaction coupling. Instead, electron coupling is used, this being provided by connecting one side of the valve filament to a tapping on the tuning coil. The latter can be an ordinary five-turn plug-in coil, the tapping being soldered at a point about two turns from the earth end. As an alternative, a small clip could be used to find the optimum tapping position before finally soldering the lead.

The I.F. transformers are shown as being of the 465-ke/s type, and these are suitable for sound reception. The second valve is an H.F. pentode, and an HL type triode is used for second detection. The ultra-short-wave H.F. chokes should be good ones of low resistance, since one of them is used to carry the L.T. current to the first valve. It is scarcely necessary to add that all components associated with the first valve should be compactly arranged, so that the connecting leads are extremely short. As with the super-regenerative receiver, the tuning condenser should be provided with an extension spindle and a slow-motion drive, since tuning is, naturally, quite sharp. One of the advantages of the superhet is that the only control is that for tuning, although it is generally found worth while in a circuit such as that described to apply the H.T. current to the first valve through a 100,000-ohm variable resistance, this providing a reasonable measure of control over reaction coupling, and facilitating the matter of maintaining steady oscillation over the full tuning range.

LEAVES FROM A SHORT-WAVE LOG

Still They Come

THE 40-metre amateur band, as already reported, has been invaded by a number of Spanish transmitters all intent on broadcasting war news and propaganda, not only in their native tongue but also in Portuguese, French and English for one or other of the combatant parties. Daily at 19.30 G.M.T. in addition to the stations already mentioned in these columns, you may hear EA1AZ, Corunna, on about 42.20 metres, which appears to be relayed simultaneously by two other weaker transmitters on approximately 42 and 42.80 metres, of which the call letters have not been picked up. On the other hand, the following are the call-letters (not mentioned in the Call-book) which are also to be logged on or around that portion of the waveband. EA1DS, Torre Lavega; EA2EJ, San Sebastian; EA3FE, Reos; EA4JR, Madrid; EA1BT, Sarria, Lugo; EA9AH, Tetuan (Spanish Morocco); EA5ZB, Valencia; EA4CN, Madrid; EA7PE, Granada; EAJ10, Radio Labor, Saragossa; EAJ2DH, Jaca; EA3DV, Sabadell, Barcelona; and EA2BK, Vittoria. It would appear that these are mostly amateur stations which have been taken over by the warring parties.

A Cuban Puzzle

The medium-waver CMX, Havana, operating on 325.9 m. (920 kc/s) with a power of 1 kilowatt, has opened up a short-wave

(Continued on page 115)

TELEVISION DEVELOPMENTS

A NEW LARGE DIAMETER TUBE FOR TELEVISION REPRODUCTION

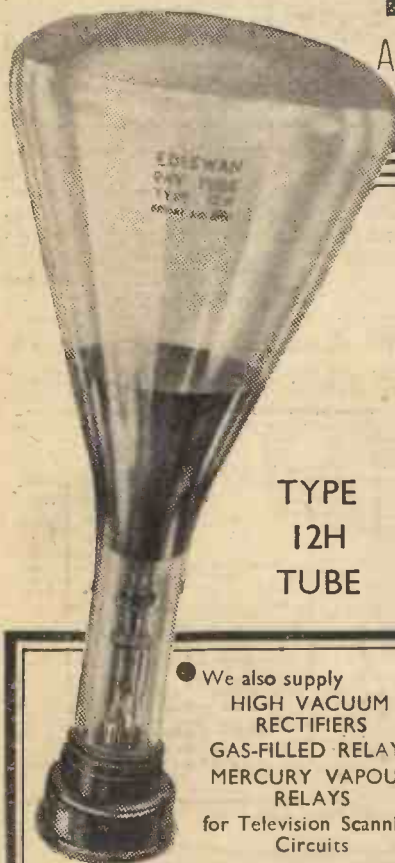

TYPE 12H TUBE

● We also supply
HIGH VACUUM RECTIFIERS
GAS-FILLED RELAYS
MERCURY VAPOUR RELAYS
for Television Scanning Circuits

The Ediswan Type 12H tube has a screen diameter of 12" giving a television picture 10" x 7½" without distortion.

The screen is of special material giving a close approximation to a black-and-white picture.

Specification :

Indirectly heated high vacuum tube. 2nd Anode Volts - - 1200
Heater Volts - - - - 2.0 1st Anode Volts - - 150-400
3rd Anode Volts (Max.) - - 6000 Sensitivity(mm.pervolt) 950/V*

*V=final anode volts

List Price £15.15.0

ENTIRELY BRITISH MADE

EDISWAN RADIO VALVES

THE EDISON SWAN ELECTRIC CO. LTD. 155 CHARING CROSS RD., LONDON, W.C.2

R.E.299

USED BY ALL GOVERNMENT DEPARTMENTS

LETTERS FROM READERS

The Editor does not necessarily agree with opinions expressed by his correspondents.



All letters must be accompanied by the name and address of the sender (not necessarily for publication.)

TI4NRH (Costa Rica): Reports Wanted

SIR,—I have received a letter from Señor Marin, the owner of TI4NRH, the famous Costa Rica amateur broadcasting station, stating that I am the first to report reception in Scotland. He mentions in his letter that he will send a unique verification certificate to all who report reception. The station is on the air every morning from 03.00-04.00 and 05.30-06.00 B.S.T. The power used is 150 watts, and transmissions take place on 9,670 kc/s and 14,428 kc/s. Reception reports should be addressed to: Señor Amando Céspedes Marin, Apartado 40, Heredia, Costa Rica.

This is the famous NRH station which was being well received in Europe in 1931 on 7½ watts.—JAMES T. BLACKWOOD (Glasgow).

Service!

SIR,—I have now had ample opportunity of trying out my receiver after adjustment by you recently, and should like you to know that I am now very pleased with it. I feel that I have a receiver now, and not a "box of bits," as it was before. Running round the dial a few evenings back I received thirty-five stations, all at very good strength and free of interference. This seems to me to be more than adequate. I should like to express my very best thanks to you for all the trouble you have taken in putting this right for me.—N. F. FILEWOOD (E. Dulwich).

W5BVH, Texas

SIR,—I have just received QSL and letter from W5BVH, Houston, Texas. In the letter he says he wishes for, and would greatly appreciate, a schedule with a "G" station or stations, as the "East coast boys" make it hard for him to contact the "G's." Details of W5BVH's Tx., etc., as follows:

Tx.: 53XTAL osc. 802 buffer. PP 800's final. XTAL mike. 801's M and D.

Input: 175 watts.

Freq's: 14,162 kc/s and 14,244 kc/s.

132ft. Zepp. Operator: Herman M. Tomlin.—W. E. G. BARTLETT (Weymouth).

A S.W. Log from Manchester

SIR,—As I have not yet seen a S.W. log from this district, I enclose mine. The set used was a 2-valve, simple receiver, built from components I extricated from the junk-box, and the aerial used is a 40ft. inverted "L" type, with a moderately good earth. I have never listened-in later than 11.30 p.m.

Broadcast stations:—DJA, DJB, DJD, DJN, DLM, DJL, DJC, DZA, GSC, W2XAD, W2XAF, OLR, RW96, HAS3, IRS, EAQ, W8XK, VK2ME, FYA 19 and 25 m., 2RO, GSD, RK1, EA8AQ, W1XK, W3XAL, W2XE.

Amateurs:—W8IKA, W2XK, VOJH, W2FF, W2FHJ, W1YI, W2LO, EI6F, and also forty-eight "G" stations. I noticed that G5NI Birmingham "works" quite a few American stations at good strength.—ERNEST DALE (Manchester).

From an American Reader: Correspondent Wanted

SIR,—I wish to congratulate you on your publication, PRACTICAL AND AMATEUR WIRELESS. A gentleman, with whom I correspond in Cadishead, M/c., sends me a copy weekly, and I find your columns very interesting! I was particularly pleased to read, in issue of August 29th, the log submitted by E. Wilkinson of Alford, Lines, and would appreciate it very much if he would drop me a line? I am an S.W.L., and my rig is a ten tube super-heterodyne, inside aerial, running east to west. DX is slowly returning to normal here in the States, though we're having our rainy season at present, and QRN is rather heavy occasionally.

During the past twelve months I have logged thirty-seven countries and have received approximately 374 verification cards. During the past two or three months I have been listening on 20 metres only and have sent reports to the following stations—amateur and commercial:—W4AEZ, W2AKK, NY2AE, COCQ, TPA3, PY2AK, HBO-J, TI2RC, TI2AV, TI2FG, TI3AV, CO2HY, CO2KY, CO8VS, CO2QQ, CE1BC, VP6YB, VE1CR, G5NL, HH2B, HI7G, HI5X, WI1RO, VPD2, W3AKE, W2DH, K6JLV, K6KKP, W5FIY, VK2NL, VK2QR, VE4SS, and ON4VK. The latest veri's received were G5NI, VE4WR, W7ACL, BRS2498, W4EBW, W9RBC, W9HBP, W2BTU, and one commercial—HAT4. I still have thirty-one reports out, but expect cards in the next mail. Also have QSL's coming in from OA4AA and OA4AK.

What I am trying to do is this: I am reporting a station in each district in the States, on 20 metres only. I hope to have a card which will represent the ten American districts. (I've already logged and reported the Schooner *Morrissey*, so I've covered the W10's.) When I have accomplished this, I intend to report same to ten Canadian districts; then, the three Mexican districts. In the meantime, I shall be on the look-out for any DX,

(Continued overleaf)

CUT THIS OUT EACH WEEK

Do you know

—THAT in cases of instability, when adopting screening for certain leads, the grid leads should not be screened in view of the risk of loss of signal strength.

—THAT special short-wave type valves have their grid connected to the top cap.

—THAT a low-capacity aerial-series condenser for short-wave reception can be made by twisting two two-inch lengths of Glazite tightly together, connecting two ends to aerial and aerial socket respectively, and leaving the other two ends free.

—THAT wet electrolytic condensers can be used in mains sets to prevent voltage surges.

—THAT an ordinary lighting lamp can be used temporarily in place of a barretter or dropping resistance in the heater circuit of A.C./D.C. receivers.

—THAT a new A.C. mains output valve with a 2-volt filament is now available.

PETO-SCOTT

Components, Kits, Receivers or Accessories for Cash or C.O.D. or on our own system of Easy Payments. C.O.D. Orders value over 10/- sent carriage and post charges paid (GT. BRITAIN ONLY).

LIMIT ALL-WAVE 4

KIT "A" Authors' Kit of first specified parts, less valves-cabinet and speaker. Cash or C.O.D. Carriage Paid, £4:16:6 or 12 monthly payments of 8/8. With 4 specified valves. Cash or C.O.D. Carriage Paid, £6:3:0 or 12 monthly payments of 11/8.

Detailed priced list of parts on request.

Peto-Scott 1937 SUPER SENSITIVE S.G.3 KIT

A NEW VERSION of AN OLD SUCCESS

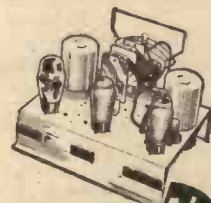

- SCREENED WAVE WOUND AIR CORE COILS.
- DRILLED GREY ENAMELLED STEEL CHASSIS.
- PICK-UP CONNECTIONS.
- FULL INSTRUCTIONS WITH EVERY KIT.

4 DOWN

And 11 monthly payments of 4/8

Without a doubt the very last word in sensitive and selective Kits, capable of providing real entertainment from numerous British and Foreign stations. Screened grid, detector. Harries Pentode Output valves.

KIT "A" 47/6

Cash or C.O.D. Carriage Paid. Complete kit of parts including ready-drilled enamelled steel chassis, less valves, cabinet and speaker.

FULL DETAILS IN BOOKLET "B" (See Coupon)

Peto-Scott NOISE-SUPPRESSING ALL-WAVE AERIAL



- Eliminates Man-Made Static.
- Increases Signal Strength on all Bands.
- Improves Selectivity.
- Waterproof and Weatherproof.
- Two Transformers.

Obtain utmost entertainment by using this Peto-Scott Aerial Outfit, the first really economical solution for overcoming the noise of man-made static. AERIAL OUTFIT COMPRISES Duplex enamelled stranded aerials, insulators, waterproof "Acorn" wires, Aerial and Set Transformers, assembled and ready with instructions and drawing illustrating the method of erection.

CASH OR C.O.D. CARRIAGE PAID 17/6

ASSEMBLED AND READY FOR ERECTION.

—Described in Booklet "B."

Peto-Scott 3-STATION SUPPRESSOR



Constructed to eliminate the local station simultaneously with another medium wave station and also a long-wave station. The unit is equipped with iron-cored coils and air-spaced condensers. Only two simple connections and no alteration to send your receiver necessary.

Cash or C.O.D. Carriage Paid, £1/2/6. 2/6 or 10 monthly payments of 2/6. Only

—Described in Booklet "B."

W.B. CABINET SPEAKERS



MODEL 37SC A Cabinet instrument giving superb reproduction, with power handling capacity of up to 5 watts undistorted. The turn of a switch adjusts it to match any set made. With volume control.

Cash or C.O.D. Carr. Paid £3/3/0, or 5/- down and 11 monthly payments of 5/9.

If required complete with WB "Long Arm" Remote Control. Cash or C.O.D. Carriage Paid £3/18/6, or 12 monthly payments of 7/8.

Any other "WB" Cabinet or Chassis Speaker available on attractive Easy Terms.

FREE TO CONSTRUCTORS

- Send this coupon for your COPY of the following:
- (a) BOOKLET "B"—describes complete range of Peto-Scott 1937 Productions (Kits, Speakers, Eliminators, etc.).
 - (b) BOOKLET "C"—describes wonderful selection of other manufacturers' lines we are able to supply on EASY TERMS.
 - (c) BOOKLET "D"—full wiring diagrams of 4 Tested Circuits. (Strike out those not required.)

PETO-SCOTT CO., LTD., 77 (Pt. V. 4), CITY ROAD, LONDON E.C.1. Clark: 9406/7. WEST-END: 2 (Pt. 4), HIGH HOLBORN, LONDON, W.C.1. Holborn 3248.

Name
Address

EST: 1919

Let Us Send You This 40-Page Booklet—Free



It gives full information regarding various I.C.S. Courses of Instruction in Radio work.

The Radio industry is progressing with amazing rapidity. Only by knowing thoroughly the basic principles can pace be kept with it. I.C.S. Instruction includes American broadcasting as well as British wireless practice. It is a modern education, covering every department of the industry.

OUR COURSES

Included in the I.C.S. range are Courses dealing with the Installing of radio sets and, in particular, with their Servicing, which to-day intimately concerns every wireless dealer and his employees. The Equipment Course gives sound instruction in radio principles and practice.

There is also a Course for the Wireless Salesman. This, in addition to inculcating the art of salesmanship, provides that knowledge which enables the salesman to hold his own with the most technical of his customers.

Then there are the Preparatory Courses for the City and Guilds and I.W.T. Exams.

We will be pleased to send you details and free advice on any or all of these subjects. Just fill in, and post the coupon, or write in any other way.

International Correspondence Schools, Ltd.,
Dept. 94, International Buildings,
Kingsway, London, W.C.2.

Without cost, or obligation, please send me your "Radio" booklet of information about the Courses I have marked X

- COMPLETE RADIO
- RADIO SERVICING
- RADIO EQUIPMENT
- RADIO SERVICING AND SALESMANSHIP
- WIRELESS ENGINEERING
- EXAMINATION (state which)

Name

Address

(Continued from previous page)

and report it also. Another month, and DX will be back to normal again, and that's when we American boys "go to town"! English amateur stations are very seldom heard in this locality, due to heavy C.W. on the H.F. end of the band, but occasionally one hears them at fair signal strength.

I would appreciate it very much, if any of your readers would drop me a line. I should be very happy indeed to correspond with anyone anywhere throughout the Empire. Please accept my best wishes for your wonderful magazine, and I hope to write again very soon.—WARREN H. STARK, 2117 North 62nd Street, Wauwatosa, Wis., United States.

Appreciation from an Indian Reader

SIR,—Thank you for the information forwarded to me regarding "The British Long-Distance Listeners' Club." May I take this opportunity of saying a few words about PRACTICAL AND AMATEUR WIRELESS. I have been a regular reader for the last two and a half years and am the proud owner of all the issues for that period.

I have constructed five sets, of which three are short-wave portables, and all the circuits and constructional details were taken from PRACTICAL AND AMATEUR WIRELESS. I greatly appreciate these circuits and the surprising clearness of the receivers which you present to us from time to time. I would very much like to correspond with any of your readers who care to write to me.—ROMESH A. AROOR (Bombay, India).

QSL Cards

SIR,—I have read with some interest the correspondence regarding QSL cards, and I should like to make a few observations on the matter.

Those people, and there are many of them, who collect QSL cards just for the sake of wall decoration or personal prestige, and who have scarcely any other motives, are a nuisance, and I fear they must be held largely responsible for the refusal of many stations to QSL. Their reports are often useless as a detailed report is usually required for S.W. working.

There is generally no need for a S.W.L. to send reports to an amateur, especially in Europe, as these stations can usually make direct QSO, conditions permitting. There is also not much point in sending a report to, say, an East Coast American, when you hear him talking to a European, although if he is heard to be working "down south" he may be interested to learn how directional or otherwise his antenna may be. The East Coast stations often have high power (200-1,000 watts) with beam antennas to Europe and are therefore not surprised to learn that they have been heard in Europe while in QSO with an English amateur.

Reports on 10- and 5-metre signals are nearly always welcome, and will get a card if they are any good. This applies to real DX on the other bands, but some Eastern stations are not too good in this respect even with stations they have worked.

It should be remembered that cards cost money, and also that the time required is very considerable, much more than some of your readers seem to think, especially if the cards are not sent via RSGB.

It is a good plan, and economical, to send reports only to such stations as ask specifically for general reception reports from S.W.L's. These stations are usually S.W. broadcasters, but even these

do not always keep their promise to send a card.

Commercials, generally speaking, do not want QSL cards as they are only concerned with their signals being heard at the place they are sending to and not elsewhere. Anyway, a commercial service is not started until ample data is available as to reception at the reception point required.

Finally, I should like to know if there is any demand for a single signal receiver (superhet) with a beat oscillator for amateur bands only, so that it could be accurately calibrated for work on these bands.—REGINALD A. TETT (Salisbury).

The First Radio Christmas Greetings?

SIR,—I came across a point of interest on wireless history this week that might be worth printing.

Whilst talking to an elderly friend of mine regarding wireless, he stated he remembered Marconi, Kemp and Bullocke (especially the second named) in their early experiments. He then showed me a postcard with Christmas greetings on it and dated 1898. It was addressed to his wife and had a note on it signed by Bullocke, stating this wireless Christmas greeting had been received at their shore station and was from a ship that Marconi and Kemp were experimenting on and had offered to send a Christmas message for any of the crew.

I should think this was the forerunner of the wireless Christmas greetings one can now send, and doubt if there were any earlier.

Trusting this is found to be of interest.—C. STOBART (Ramsgate).

COCQ—Cuba

SIR,—I have just received a verification card and photo from COCQ of Cuba, and the doubt as to the exact frequency is dissolved. The frequency is 9,750 kc/s.

This station is the short-wave outlet of CMQ; frequency 880 kc/s, using 20 kW. I have to thank the British Short-Wave League for the information as to the address to which I sent my report, and I am glad to say that I have the honour of being a member of the above-mentioned League.—W. S. BARRETT (Barking).

Good Reader Response

SIR,—My letter appearing in the September 19th issue certainly caused a flutter. I had letters from readers asking me where to get stamps. Very charming letters, and I was only too pleased to be of some use to the gentlemen in question. Since then my receiver has been "hotted up," and tunes from 7 metres up to 180 on ordinary coils without any "fuss." I've heard a good number of new calls, so I'll give you the prefixes only.

160 m. and 80m. Bands : G, ON, PA, F3, F8, VE1, W1.

40 m. Band : G, ON, PA, F3, F8, FAS, EA, EI, GI, CT, HB.

20 m. Band : W1, W2, W3, W4, W5, W8, W9, CO, CX, EI, FM8, HH, HI, HJ, LA, LU, LY, NY, PK, PY, SM, SU, VE1, VE2, VE3, VK2, VO1, VO4, VP3, VP6, VP9, XE2, YV.

Then, more recently, on 10 m.

10 m. Band : W4, W5, W6, W7, W8, W9. Notably : W5BDB, W5FHG, W4BYY, W5FJ, W4DXY, W4DFY, who are coming over well on 10.

Television from Alexandra Palace and from Germany is coming over well on various lengths between 6 and 8 metres, too.—E. DE COTTIGNIES (Now BRS 2562) (Prittlewell).

LEAVES FROM A SHORT-WAVE LOG

(Continued from page 112)

transmitter on roughly 25.7 m. (11,675 kc/s) of which the call comprises the letters COCX and CMX. A Spanish speaker has been heard on this channel, but so far the broadcast has not been clear enough to identify with certainty. As an interval signal three chimes were noticed, a device used by so many South Americans to-day, but which proves of little help in fixing the location of the station.

W8XK Becomes International

Listeners to the East Pittsburg (Pa.) short-wavers of the N.B.C. KDKA station, may have noticed that the call has been slightly altered. Every fifteen minutes at the close of the transmission you hear a voice boom out the announcement: W8XK, the Westinghouse International Broadcasting station at Pittsburg, Pennsylvania relaying the regular programme of KDKA. The Schenectady (W2XAD and W2XAF) transmitters are also International as, without doubt, the power at which the signals are picked up they must be heard well over the greater part of Europe in addition to both North and South America.

VP3MR Leaves Amateur Band

VP3MR, Georgetown (British Guiana) is now working on 49.39 m. (6,075 kc/s). Calling itself *The Voice of Guiana* the station broadcasts daily between G.M.T. 21.45-01.45 on weekdays, but only until 23.45 on Sundays. A special daily feature is a relay of Military Band music from the Promenade Gardens, Georgetown. Identification is facilitated by the fact that many concerts are sponsored in the American style.

A Less-frequently - logged Transmission

El Prado, Riobamba, Chimborazo (Ecuador), on 45.33 m. (6,618 kc/s), according to a report received from the United States, has blossomed out as a full 2-kilowatt and also extended its daily schedule. The call in both Spanish and English is given out at regular intervals by a woman announcer (Señorita Judy), *You are listening to Radio station el Prado*, and at the close of the transmissions a bi-lingual greeting is heard: *We are now bidding you all Buenos noches*. The station is on the air every Friday between G.M.T. 02.00-04.15 with a selected programme destined to English-speaking listeners.

Radio Letter Box

Readers may recall the original Radio Letter Box instituted some years ago by the Katowice (Poland) station director, and in the course of which replies by microphone were given to correspondents all over the world. Of recent months the same idea has been adopted by Zeesen (Germany) in its transmissions to Africa and Asia.

You will also hear Birthday greetings reminiscent of the B.B.C. Children's Hour, and in some instances personal messages of a private nature to friends and acquaintances overseas. Rome, also, every Monday after midnight replies to its radio fans in a similar manner, utilising for this purpose its powerful short-wave transmitters.

PHOHI Extends its Broadcasts

PHI, Huizen, on 16.88 m. (17,770 kc/s), is now on the air thirty minutes earlier than has hitherto been the case, and opens its broadcasts for the Netherlands East Indies at 12.00 G.M.T. with the playing of the National Anthem (*Wilhelmus van Nassau*). The transmission ends towards 15.30.

AN OUNCE OF EXPERIENCE IS WORTH A POUND OF WORDS



T.C.C.
ALL-BRITISH
CONDENSERS

T.C.C. HAVE MADE CONDENSERS-AND CONDENSERS ONLY FOR 28 YEARS

THE TELEGRAPH CONDENSER COMPANY LIMITED

WALES FARM ROAD · N · ACTON · LONDON · W · 3 ·

THE OUTSTANDING WORK FOR ALL ELECTRICAL AND WIRELESS ENGINEERS

" PRACTICAL ELECTRICAL ENGINEERING "

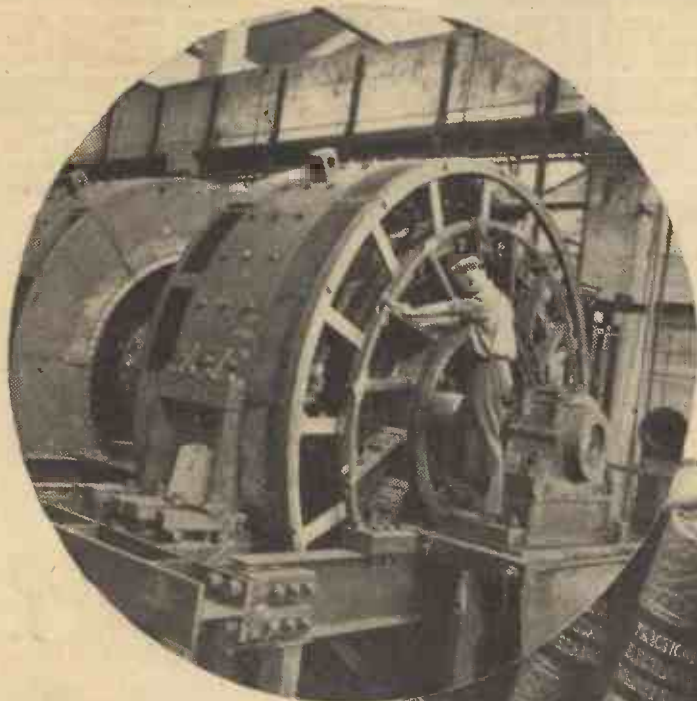

IN Electrical Engineering, advancement and success come to the man who is best equipped to tackle and understand the multifarious jobs and problems he may encounter. This new and up-to-date work will help you to acquire the necessary combination of theoretical and practical knowledge. It is invaluable alike to the Student and to the practising engineer. It shows the approved methods of dealing with every type of work, from the installation, erection, wiring and maintenance of an electrical plant for a small house to that of a large factory replete with the most up-to-date equipment.

In addition, the most modern applications of electricity, including sound - film reproduction, wireless, etc., are fully dealt with and the work contains a great deal of most valuable data which cannot be found in any other hand-book.

Send for the illustrated prospectus — and judge for yourself.

Complete in 5 Handy Volumes

Bound in full Blue Moroquette. This strong binding is oil- and water-proof so that the books may be used freely in the Workshop, etc., without risk of damage.

A few of the important subjects :

- WIRELESS AND GRAMOPHONES.
- ELECTRICAL MACHINERY.
- GENERATION AND DISTRIBUTION.
- INSTRUMENTS AND METERS.
- WIRES AND CABLES.
- LIGHTING AND ILLUMINATION.
- INSTALLATION WORK.
- OPERATION AND MAINTENANCE WORK.
- INDUSTRIAL USES OF ELECTRICITY.
- THEATRE AND CINEMA WORK.
- TELEGRAPHY AND TELEPHONY.
- ELECTRIC TRACTION.



OVER
30 SPECIALIST
 CONTRIBUTORS
 MORE THAN
1,000
 ILLUSTRATIONS
2 FOLDING PLATES
 SECTIONAL MODELS
 IN FULL COLOURS
 OVER 1,900 PAGES

To The HOME LIBRARY BOOK COMPANY
(George Newnes, Ltd.)

8-11, Southampton St., Strand, London, W.C.2

Please send me, without any obligation to purchase, full particulars of PRACTICAL ELECTRICAL ENGINEERING and details of your scheme of Easy Payments with immediate delivery.

Name

Address

.....PRAC. W. 101036

If you do not wish to cut your copy, send post card mentioning "Practical Wireless" to address above.

POST THIS COUPON TO-DAY

We will send you full details of this most valuable reference work

ABC OF THE MODERN RECEIVER
(Continued from page 107)

voltages the valve loses a considerable degree of its efficiency.

The H.F. Pentode

This difficulty is obviated when using a high-frequency pentode valve, as shown in Fig. 4, and in which a third grid is placed between the anode and screening grid and connected to the filament or to earth. The third grid produces a number of other beneficial effects, which need not be explained in detail. The main point is that this type of valve has been proved to be more efficient than any other

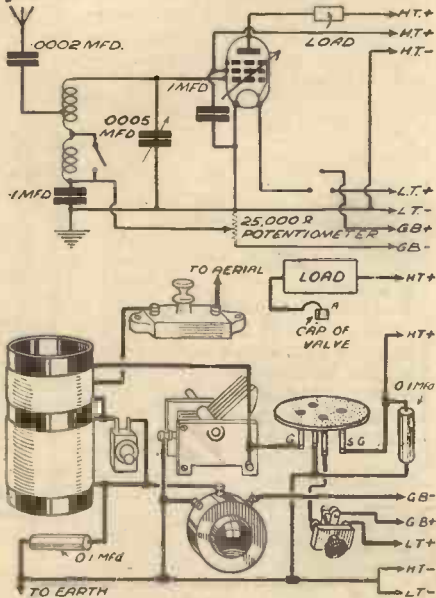

Fig. 5.—This shows the usual method of providing variable-mu volume control. The potentiometer serves to vary the G.B. voltage applied to the V.M. H.F. pentode.

for high-frequency amplification, and is now employed almost universally in one form or another.

Variable-mu

There is yet another point in connection with H.F. amplifiers which has not been explained. That is the use of so-called variable-mu valves; these may be of the screen-grid or H.F. pentode form, but are nearly always the latter. These are so designed that the amount of amplification which they provide can be varied over a wide range by applying different voltages to the grid in addition to the signal voltages. In other words, the *negative bias* on the grid can be changed, and as it increases the valve gives less amplification. This feature is employed as a simple and very effective means of *pre-detector* volume control. There are various methods of applying the variable grid-bias voltage, but the most usual is illustrated in Fig. 5. Here it can be seen that the lower end of the tuning coil is disconnected from earth and the filament, a fixed condenser (usually about .1 mfd.) being used to complete the high-frequency circuit and to allow a free flow of H.F. current. A lead is taken from the coil to the grid-bias supply, so that the voltage can easily be changed. In practice, a potentiometer is used as a simple means of providing a smoothly-varying voltage from zero to the maximum of the grid-bias battery, and is connected as shown in Fig. 5.

One end of the potentiometer—which is really a fixed resistance with a slider which can be caused to make contact at any point on the resistance—is joined to the *earth line*, and the other end is connected to the negative terminal or socket on the G.B. battery. Also, it should be observed, the positive end of the battery is connected to L.T. negative through the three-point switch, when this is in the "on" position. When the set is switched on the voltage of the G.B. battery is across the potentiometer, so that one end of the resistance element is positive and the other negative. Actually, it is better to consider the earth-line as being neutral and the other end of the potentiometer as negative, when it can be understood that any negative potential from nothing to the maximum voltage of the G.B. battery can be obtained. For example, if the battery were of nine volts, the bias applied when the slider were

half-way between the ends would be 4½; when it were one-third of the distance from the earth end the voltage would be 3 (negative); and when it were one-third of the distance from the negative end, the voltage would be 6, and so on.

It has not yet been explained why a three-point on-off switch is shown in the circuits illustrating the use of variable-mu control. It is simply to prevent the flow of current through the potentiometer when the set is out of use. The potentiometer may have a value between 25,000 and 50,000 ohms, but even the higher value permits the passage of a few milliamps of current; if this were to flow continuously the G.B. battery would soon be exhausted. As will be seen, the three-point switch disconnects the positive terminal of the G.B. battery at the same time as it breaks the low-tension or accumulator circuit.

(To be continued)



SHERLOCK HOLMES SAYS..

No Guessing

PIFCO makes certain...



The "ALL-IN-ONE" RADIOMETER for A.C. or D.C.

The "ALL-IN-ONE" RADIOMETER for A.C. or D.C.—For testing electric or battery radio sets. Anybody can trace faults with this wonder instrument. Finished in black bakelite. Size of dial, 1½ in. by 1 in., complete with leads. Price **12/6**

PIFCO

Your radio has no secrets from the Pifco Radiometer. Anyone, however inexperienced, can trace faults with this wonder instrument. Any radio set can be tested—either A.C. or D.C., Mains or Battery operated. Solidly constructed, with fine bakelite case, the Pifco Radiometer has readings for high and low voltage, milliamperes, continuity test, and a special socket for testing valves.

Get one of these amazing instruments from your local dealer today, or write for Pifco Testmeter Folder, post free from:—

PIFCO LTD., WATLING STREET, MANCHESTER, or London Office, 150, Charing Cross Road, W.C.2

ROTAMETERS and RADIOMETERS
PIFCO ON THE SPOT WILL TRACE YOUR TROUBLES LIKE A SHOT

Facts and Figures

COMPONENTS TESTED IN OUR NEW LABORATORY

Goltone Radio Suppressor Unit

IT is now well known that various domestic electric appliances can give rise to interference on the radio, and the correct method of suppressing such interference is to fit an H.F. filter to the mechanism. Where this consists of an exposed motor such a filter may be placed immediately on the brushes, or similar position where the interference arises, but in some pieces of apparatus there is no ready method of access to this mechanism. In such cases the simplest method of applying the interference suppressor is in the mains leads, and for

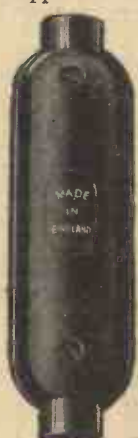

The Goltone Radio Suppressor Unit.

such a position the new Goltone device, illustrated on this page, will be found highly suitable. It consists of a bakelite case containing the components for the filter, and connecting screws for the leads. The components are designed to be impervious to heat and moisture, and when the connecting cable is joined to the correct terminals and the insulated housing clamped together the cord is as strong as in the original instance and the device is automatically included in the circuit.

The cord grip is sufficiently strong to prevent the leads from being pulled adrift even if the cord is unduly stretched. The unit is tested at 2,250 volts and is made to the B.S.S. specification, suitable for either A.C. or D.C. circuits up to 250 volts. The price is 5s. 6d., and it may be used on loads up to 10 amps.

All-Power Transformers

A COMPREHENSIVE range of mains transformers is manufactured by All-Power Transformers, Ltd., and a sample has been submitted to us for test. This is type PT/B, and is illustrated on this page. A substantial core is employed, and aluminium castings are employed both for clamping and for the mounting of the bakelite terminal strips. The ends of the windings are eyeleted to these strips and double-ended tags are employed so that the external connecting leads are effectively a continuation of the actual windings. (It should be unnecessary to add that when making these connections the iron should be sufficiently hot to ensure that the wire is attached in the shortest possible time, otherwise there is a risk of the ends of the windings being unsoldered.) The primary winding is tapped so that any mains voltage from 200 to 250 may be obtained in steps of 10 volts, and the secondaries of the model submitted are rated at 350-0-350 at 60 mA, 4 volts at 2.5 amps., and 4 volts at 4 amps. Under test the high-tension secondary was found to be 352 volts at 60 mA., and the low-tension secondaries were found to be very accurately rated. A fairly wide variation of current on the L.T. secondaries did not result in a very wide variation in the voltage, and the regulation of the transformer is very good

indeed. The transformer is well made, and can be confidently recommended. The price of the model tested is 15s., and the weight of this particular model is 4½ lbs.

Morphy-Richards Pick-up

A LOW-PRICED pick-up has been submitted for test by Morphy-Richards, Ltd., and this is of the all-bakelite type, with non-rotatable head. As may be seen from the illustration, this is designed on conventional lines, and is of the lightweight type. No volume control is incorporated in this particular model, but we understand that a special model is now available with this feature incorporated at a slightly higher cost. The rear mounting is also of bakelite and is provided with a stop so that the arm cannot be turned too far in either direction. The range of movement is, however, adequate to enable the pick-up to be used with a 12in. record and also to run off at the centre of some of the 6in. records which are now available. A substantial length of twin lead is fitted, but no screening is provided. The windings are of the high-resistance type, designed for inclusion direct in the grid circuit of a standard valve



A new pick-up by Morphy-Richards.

without the inclusion of a matching transformer, and the design is such that compensation for the recording amplitude is effected. When tested on standard records it was found that the bass recordings were sufficiently amplified to provide a good balance of reproduction, and the degree of balance was found comparable to an early type pick-up used with a commercially-designed tone compensator. The higher frequencies cut off rather sharply, but rather than a defect this was found to be an advantage as it substantially reduced needle scratch. In fact, with the particular model tested the surface noise was found to be remarkably subdued, yet without appearing to affect the higher musical frequencies. The price of this instrument is 14s. 6d., and for the additional volume control an extra 3s. is charged.

Pye Pocket Aerial

AN ingenious pocket aerial has been introduced by Pye Radio, and is illustrated herewith. This ingenious device is designed for use on demonstration receivers, or with portable and similar receivers, where an aerial is not normally required. As may be seen from the

illustration the device is made up in the form of a fountain-pen or pocket-pencil, complete with clip. Inside this is a coiled wire of a springy nature which is attached at one end to the plug point and at the other to the inside of the barrel portion of the device. When the cap is removed the coiled wire may be drawn out, and a total length of 16ft. is available in this manner. The barrel must, of course, be attached to some fixed object in order to keep the aerial in position, the other end being plugged into the aerial socket of the receiver. The overall length of the device when closed is approximately 7ins., and the diameter is only ¼in. The price is 2s. 6d.



Pye Pocket Aerial.

Wearite Volume Control

A NEW type of combined volume control and on/off switch has just been introduced by Messrs. Wright and Wearite. This is of the bakelite moulded type, having the switch mechanism mounted on the base of the control and operated through the control spindle. The element is of the composition type, with a wiping contact of the brush type. This is mounted on a bakelite disc, thus rendering the control spindle dead so far as the control is concerned. The switch is of the toggle Q.M.B. type and comes into action almost at the end of the range of movement of the control, wasting a very small portion of the element. As this is graded to form a logarithmic law the portion of the control which is un-

used is of no moment in ordinary apparatus. The action is very smooth and the switch action is clean and certain. Soldering tags are provided for connecting purposes, and the standard one-hole fixing bush is fitted. The control may be obtained in various ratings and resistance values, and the price of the 50,000 ohm model is 4s. without the switch, and 5s. with the switch.

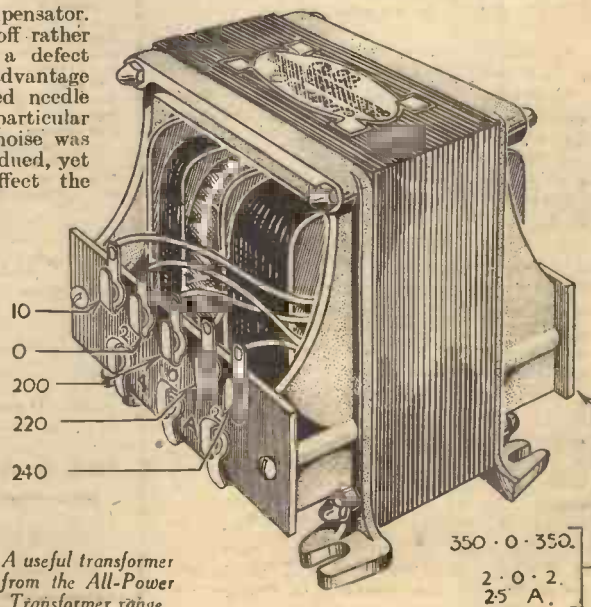

A useful transformer from the All-Power Transformer range.

B.L.D.L.C. NEWS

THE following interesting letter has been received from Mr. E. Barrs in response to his request for reports of a short-wave station. We also include a letter received from another member of the Long Distance Listeners' Club regarding Mr. Barrs' suggestion, and perhaps other members would care to give their views in order that we may make suitable arrangements to assist those who are anxious to obtain detailed reports of various transmissions:

"I think this is the first attempt at reporting a short-wave station over a certain period by S.W.L.'s all over Great Britain, and I hope to make this scheme a success. If I do not get more reports than I did for W8XX, 19.72 m., it certainly will not prove a success. You will see by the results of W8XX that it is possible to give a very useful and interesting report, if only S.W.L.'s would send me reports and so support the scheme. For the benefit of S.W.L.'s who missed the particulars in this journal, here is the scheme again and, incidentally, as this is the second attempt, I have chosen a different S.W. station: S.W.L.'s send me their reports of W2XE, 19.65 m., taken during September, 1936 (any day, any time), and I undertake to do the following:

1. Draw a graph showing the average strength (in Great Britain) of the station under review, each day of the month on this graph.

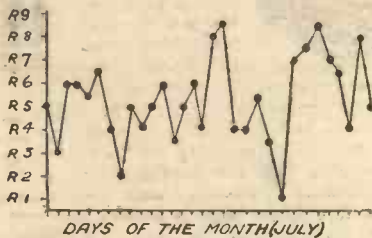

Graph of W8XX (19.72 m.), compiled by Mr. Barrs from S.W.L.'s reports. The time period (shown as the peak period), is from 21.00 to 22.00 B.S.T. for the month of July.

2. Write a list of the average strength in each county of Great Britain.
3. Find out from the data in reports which type of antenna is most efficient, also which is the best listening time.
4. Send the results of above to the station in question.
5. Have the results published in this journal.
6. If possible, ask the station to send back an 'Official Letter of Thanks' to the S.W.L.'s who help in the scheme, this to be reprinted in this journal with list of S.W.L.'s names. It has just struck me that most S.W.L.'s listen in on the amateur bands, so I have decided to take a test of a U.S.A. amateur, and if it proves a success we will continue with others, so will all 'Ham' fans please send me reports of W1CCZ for October, 1936, and I will undertake to do the same as above. I would like all reports of both stations in by November 7th, 1936. Now, to give the data gathered from the reports of W8XX, 19.72 m., you will see by the graph the average strength of this station

in Great Britain. The graph is taken of the peak period daily, i.e., between 21.00 B.S.T.-22.00 B.S.T., according to the data; the average antenna in use is the inverted L type. Owing to so few reports, I cannot tell which type is most efficient. The average strength in N.S.E. and W. is as follows: N—not enough data; S—R4 to R8; E—R3 to R6; W—R4 to R6. On the whole, W8XX seemed to be received very badly during July. Well, this finishes the data of W8XX. I have sent the results to the station owners and have asked them to send back a 'Letter of Thanks' to S.W.L.'s, who helped."—E. A. J. Barrs, B.L.D.L.C. 3260, B.S.W.L. 236, 4, King's Road, Enham, Andover, Hants.

A Suggestion for B.L.D.L.C. Members
SIR,—With reference to the suggestion for B.L.D.L.C. members put forward

by E. Barrs of Andover and published in your journal dated August 22nd, and September 19th. Why, may I ask, should station W8XX be chosen, for surely Mr. Barrs must know, from B.L.D.L.C. correspondence in the past, that W8XX is on the club's "black list." Apart from this, W8XX is the world's pioneer short-wave relay station, and quoting from the station owners, "their reception is world-wide." Therefore reports are not really necessary, at least to the extent of the published suggestion. Why not send reports to HH2S, Haiti, VQ7LO, or to CR6AA, Lobito, stations which are not so easily logged, and whose owners would greatly benefit from the valuable data Mr. Barrs suggests collecting, and which I feel sure would be much appreciated.—ERNEST J. LOGAN (Hertford).

OPEN LETTER TO MR. SOMEBODY AND HIS SON

DEAR SIR,—The natural desire of most parents is to give their children a fair chance in life in the form of a good College Training, also there are many young men who would like to go to College but for some reason are not able to do so. Let us tell you here and now you can get a Complete College Training without having to go anywhere, and at a reasonable monthly fee for tuition. For well over 30 years we have been training students for all the Key positions, by post, in all parts of the world. Distance is nothing when you are studying by your own fireside.

The nature of our business makes us keep in touch with employment requirements, therefore we specialise in preparing students for the good positions which we know exist, and for all the worth-while examinations. Write to us for FREE particulars of any subject which interests you, or if your career is not decided, write and tell us of your likes and dislikes, and we will give you practical advice as to the possibilities of a vocation and how to succeed in it.

You will be under no obligation whatever, it is our pleasure to help.



DO ANY OF THESE SUBJECTS INTEREST YOU?

- | | | |
|--|--|--|
| <ul style="list-style-type: none"> Accountancy Examinations Advertising and Sales Management All Commercial Subjects A.M.I. Fire E. Exam. Applied Mechanics Army Certificates Auctioneers and Estate Agents Aviation Engineering Banking Boilers Book-keeping Accountancy & Modern Business Methods B.Sc. (Eng.) B.Sc. (Estate Management) Building, Architecture and Clerk of Works Cambridge Senior School Certificate Civil Engineering | <ul style="list-style-type: none"> Civil Service Commercial Art Concrete and Structural Engineering Draughtsmanship, all branches Engineering, all branches subjects and exams. General Education G.P.O. Eng. Dept. Heating and Ventilation; Industrial Chemistry Insurance, Mathematics Matriculation Metallurgy Mining, all subjects Mining, Electrical Engineering Motor Engineering Motor Trade Municipal and County Engineers Naval Architecture Pattern Making Police, Special Course | <ul style="list-style-type: none"> Preceptors, College of Pumps and Pumping Machinery Radio Service Engineering Radio Communication Road Making and Maintenance Salesmanship I.S.M.A. Sanitation Secretarial Exams. Shipbuilding Shorthand (Pitman's) Structural Engineering Surveying Teachers of Handicrafts Telephony & Telegraphy Transport Inst. Exams. Weights and Measures Inspector Welding Wireless Telegraphy and Telephony Works Managers |
|--|--|--|

If you do not see your own requirements above, write to us on any subject.

Also ask for our
New Book
(Free of Charge)
**THE HUMAN
MACHINE**
Secrets
of Success

**Dept. 104, THE BENNETT COLLEGE,
SHEFFIELD.**

NOW IS
YOUR
CHANCE TO
GET INTO A
SKILLED
KEY POSI-
TION.

Practical and Amateur Wireless BLUEPRINT SERVICE

PRACTICAL WIRELESS STRAIGHT SETS. Battery Operated.		
	Date of Issue.	No. of Blueprint
One-valve: Blueprint, 1s. each.		
All-Wave Unipen (pentode)		PW31A
Two-valve: Blueprints, 1s. each.		
Four-range Super Mag Two (D, Pen)	11.8.34	PW36B
Three-valve: Blueprints, 1s. each.		
Selectone Battery Three (D, 2 LF (Trans.))		PW10
Sixty-Shilling Three (D, 2 LF (R.C. & Trans.))	2.12.33	PW34A
Leader Three (SG, D, Power)		PW35
Summit Three (H.F. Pen, D, Pen)	8.8.34	PW37
All-Pentode Three (HF Pen, D (pen), Pen)	22.9.34	PW39
Hall-Mark Three (SG, D, Pow.)		PW41
Hall-Mark Cadet (D, LF Pen (R.C.))	7.6.3.35	PW48
F. J. Camm's Silver Souvenir (HF Pen, D (pen), Pen) (All-Wave Three)	13.4.35	PW49
Genet Midget (D, 2 LF (Trans.))	June '35	PM2
Cameo Midget Three (D, 2 LF (Trans.))	8.6.35	1W51
1936 Sonotone Three-Four (HF Pen, HF Pen, Westector, Pen)	17.8.35	PW53
Battery All-Wave Three (D, 2 LF (R.C.))	31.8.35	PW55
The Monitor (HF Pen, D, Pen)	8.2.36	PW61
The Tutor Three (HF Pen, D, Pen)	21.3.36	PW62
The Centaur Three (SG, D, P)		PW64
The Gladiator All-Wave Three	29.8.36	PW66
Four-valve: Blueprints, 1s. each.		
Fury Four (2 SG, D, Pen)		PW11
Beta Universal Four (SG, D, I.F., Cl. B)	15.4.33	PW17
Nucleon Class B Four (SG, D (SG), LF, Cl. B)	6.1.34	PW34B
Fury Four Super (SG, SG, D, Pen)		PW34C
Battery Hall-Mark 4 (HF Pen, D, Push-Pull)		PW40
F. J. Camm's "Limit" All-Wave Four (HF Pen, D, LF, P.)	26.9.30	PW67
Mains Operated.		
Two-valve: Blueprints, 1s. each.		
A.C. Twin (D (pen), Pen)		PW18
A.C.-D.C. Two (SG, Power)	7.10.33	PW31
Selectone A.C. Radiogram Two (D, Pow.)		PW19
Three-valve: Blueprints, 1s. each.		
Double-Diode-Triode Three (HF Pen, D.D.T., Pen)	10.6.33	PW23
D.C. Ace (SG, D, Pen)	15.7.33	PW25
A.C. Three (SG, D, Pen)		PW29
A.C. Leader (HF Pen, D, Power)	7.4.34	PW35C
D.C. Premier (HF Pen, D, Pen)	31.3.34	PW35B
Ubique (HF Pen, D (pen), Pen)	28.7.34	PW36A
Armada Mains Three (HF Pen, D, Pen)	18.8.34	PW38
F. J. Camm's A.C. All-Wave Silver Souvenir Three (HF Pen, D, Pen)	11.5.35	PW50
"All Wave" A.C. Three (D, 2LF (R.C.))	17.8.35	PW54
A.C. 1936 Sonotone (HF Pen, HF Pen, Westector, Pen)	31.8.35	PW56
Four-valve: Blueprints, 1s. each.		
A.C. Fury Four (SG, SG, D, Pen)		PW20
A.C. Fury Four Super (SG, SG, D, Pen)		PW34D
A.C. Hall-Mark (HF Pen, D, Push-Pull)		PW45
Universal Hall-Mark (HF, Pen, D, Push-Pull)	9.2.35	PW47
SUPERHETS.		
Battery Sets: Blueprints, 1s. each.		
£5 Superhet (Three-valve)		PW40
F. J. Camm's 2-valve Superhet (two-valve)	13.7.35	PW52
F. J. Camm's £4 Superhet		PW58
Mains Sets: Blueprints, 1s. each.		
A.C. £5 Superhet (three-valve)		PW43
D.C. £5 Superhet (three-valve)	1.12.34	PW42
Universal £5 Superhet (three-valve)		PW44
F. J. Camm's A.C. £4 Superhet 4		PW59
F. J. Camm's Universal £4 Superhet 4	11.1.36	PW60
SHORT-WAVE SETS.		
Two-valve: Blueprints, 1s. each.		
Midget Short-Wave Two (D, Pen)	15.9.34	PW38A
Three-valve: Blueprints, 1s. each.		
Experimenter's Short-Wave Three (SG, D, Power)		PW30A
The Prefect 3 (D, 2 LF, RC and (Trans.))	8.2.36	PW63

PORTABLES.		
Three-valve: Blueprints, 1s. each.		
F. J. Camm's ELF Three-valve Portable (HF Pen, D, Pen)	16.5.30	PW65
Four-valve: Blueprints, 1s. each.		
Featherweight Portable Four (SG, D, LF, Cl. B)		PW12
MISCELLANEOUS.		
S.W. Converter-Adapter (1 valve)		PW48A
AMATEUR WIRELESS AND WIRELESS MAGAZINE CRYSTAL SETS.		
Blueprints, 6d. each.		
Four-station Crystal Set		AW427
1934 Crystal Set		AW444
150-mile Crystal Set		AW450
STRAIGHT SETS. - Battery Operated.		
One-valve: Blueprints, 1s. each.		
B.B.C. Special One-valver		AW387
Twenty-station Loud-speaker One-valver (Class B)		AW449
Two-valve: Blueprints, 1s. each.		
Melody Ranger Two (D, Trans.)		AW388
Full-volume Two (SG, Det, Pen)		AW392
B.B.C. National Two with Lucerne Coil (D, Trans.)		AW377A
Big-power Melody Two with Lucerne Coil (SG, Trans.)		AW338A
Lucerne Minor (D, Pen)		AW426
A Modern Two-valver	July '30	WM409
Three-valve: Blueprints, 1s. each.		
Class-B Three (D, Trans, Class B)	22.4.33	AW386
New Britain's Favourite Three (D, Trans, Class B)	15.7.33	AW394
Home-Built Coil Three (SG, D, Trans)		AW404
Fan and Family Three (D, Trans, Class B)	25.11.33	AW410
£5 5s. S.G.3 (SG, D, Trans)	2.12.33	AW412
1934 Ether Searcher: Baseboard Model (SG, D, Pen)	20.1.34	AW417
1934 Ether Searcher: Chassis Model (SG, D, Pen)		AW419
Lucerne Ranger (SG, D, Trans)		AW422
Coosor Melody Maker with Lucerne Coils		AW423
P.W.H. Mascot with Lucerne Coils (D, RC, Trans)		AW337A
Mullard Master Three with Lucerne Coils		AW424
£5 5s. Three: De Luxe Version (SG, D, Trans)	10.5.34	AW435
Lucerne Straight Three (D, RC, Trans)		AW437
All Britain Three (HF Pen, D, Pen)		AW448
"Wireless League" Three (HF Pen, D, Pen)	3.11.34	AW451
Transportable Three (SG, D, Pen)		WM271
£6 6s. Radiogram (D, RC, Trans)		WM318
Simple-tune Three (SG, D, Pen)	June '33	WM327
Economy-pentode Three (SG, D, Pen)	Oct. '33	WM337
"W.M." 1934 Standard Three (SG, D, Pen)		WM351
£3 3s. Three (SG, D, Trans)	Mar. '34	WM354
Iron-core Band-pass Three (SG, D, QP21)	June '34	WM362
1935 £6 6s. Battery Three (SG, D, Pen)		WM371
PTP Three (Pen, D, Pen)	June '35	WM389
Certainty Three (SG, D, Pen)	Sept. 35	WM393
Minutube Three (SG, D, Trans)	Oct. '35	WM396
All-wave Winning Three (SG, D, Pen)	Dec. '35	WM400
Five-valve: Blueprints, 1s. 6d. each.		
Super-quality Five (2HF, D, RC, Trans)	May '33	WM320
New Class-B Five (2SG, D, LF, Class B)	Nov. '33	WM340
Class-B Quadradyne (2SG, D, LF, Class B)	Dec. '33	WM344
1935 Super Five (Battery Superhet)		WM379

These blueprints are full size. Copies of appropriate issues containing descriptions of these sets can in most cases be obtained as follows:—
 "Practical Wireless" at 4d., "Amateur Wireless" at 4d., "Practical Mechanics" at 7½d., and "Wireless Magazine" at 1/3d., post paid. Index letters "P.W." refer to "Practical Wireless" sets, "P.M." to "Practical Mechanics" sets, "A.W." refer to "Amateur Wireless" sets, and "W.M." to "Wireless Magazine" sets. Send (preferably) a postal order (stamps over sixpence unacceptable) to "Practical and Amateur Wireless" Blueprint Dept., Geo. Newnes, Ltd., 8-11, Southampton Street, Strand, W.C.2.

RADIO CLUBS AND SOCIETIES

Club Reports should not exceed 200 words in length and should be received First Post each Monday morning for publication in the following week's issue.

THE RADIO PHYSICAL AND TELEVISION SOCIETY

The annual general meeting of this Society was held on Friday, October 2nd, when a comprehensive series of lectures, as well as several visits to radio firms, were arranged. It is hoped to continue weekly meetings as before.

A number of our members hold transmitting licences, and short-wave work is fully encouraged, assistance being given to would-be transmitters. Television will, of course, be featured in our programme, and we can give technical assistance on this subject to those interested. The Society's headquarters are at 72a, North End Road, West Kensington (Mr. West Kensington Station), and meetings begin at 8 p.m. Further details may be obtained from the Hon. Sec., M. E. Arnold, 12, Nassau Road, West Kensington, W.14.

LEEDS RADIO SOCIETY

The above Society has been formed with the object of catering for all amateur wireless enthusiasts. Demonstrations, Morse classes, and lectures are held every Monday at 7 o'clock at Oxford Chambers, and any new members from Leeds and district will be given a warm welcome. Interested readers are invited to write for particulars to the Sec., J. Kavanagh, 63, Dawlish Avenue, Leeds, 9.

NEWARK NEWS RADIO CLUB

The following special broadcasts in co-operation with this Club may interest a number of readers. TIARRH—Heredia, Costa Rica. 9,670 kilocycles. 11.30 until 2.00 a.m. E.S.T. 4.30 until 7.00 a.m. G.M.T., the first Sunday morning of every month from October to May, 1937. W2XAD-W2XAF—Schenectady, New York. W2XAF—9,530 kilocycles. W2XAD—15,330 kilocycles. November 20th, from 8.00 p.m. to 9.00 p.m. G.M.T. Bernard L. Ahman, Jr., 215, Market Street, Newark, New Jersey.

SLADE RADIO SOCIETY

On Thursday, September 17th, we had a record evening. Mr. Redgrave, of Messrs. Voigt Patents, Ltd., gave a lecture and demonstration of their loud-speaker, and its specially designed cabinet. There was an attendance of eighty people, and the extraordinary quality of reproduction filled everyone with amazement. Reproduction from records and radio seemed almost uncanny, and had the equipment been covered by a curtain, it would have been comparatively easy to have believed that the artists giving the performance were actually present in the room.

PORTSMOUTH AND DISTRICT WIRELESS AND TELEVISION SOCIETY (PORTSMOUTH CHAPTER OF THE B.L.D.L.C.)

The first autumn meeting of the above society was held in the Municipal College, when Mr. H. Leigh (2BBG) gave a lecture on "World-wide Short-wave Listening." In just over a year seventy countries have been logged, whilst from June 22nd this year to September 1st, 344 stations have been received on a 2-valve set. A short-wave converter, a 3-valve set, and an all-wave set were exhibited and demonstrated, and a large number of QSL's were shown to the members. Particulars of short-wave receiving aeriels were then given, together with blackboard circuit diagrams, best times for listening, etc. Lieut. W. Jackson, R.N., Rtd., was in the chair. The meetings will be held each alternate Wednesday in the Municipal College, and the Transmitter Section meetings and Morse practice every Monday evening at the house of Mr. H. Leigh, 20, King St., Southsea, from whom further particulars of the society can be obtained.

THE SHORT-WAVE RADIO AND TELEVISION SOCIETY (THORNTON HEATH).

This society held its weekly meeting on Tuesday, September 22nd, at St. Paul's Hall, Norfolk Road. Mr. R. E. G. Copp presided. Mr. Basil Wardman (G5GQ) gave a talk and demonstration of the Hammarlund "Super" Pro-receiver. He first gave a short description of the three types of receiver in common use—the set used for broadcast reception, the set used by amateurs for short waves, and the set designed for use in airports, ships, etc. The Hammarlund "Super-Pro," using sixteen valves, including rectifiers, is designed to give the best results on bands covering 15 to 600 metres, and has an output of 15 watts. On test the receiver justified all that Mr. Wardman claimed for it. Mr. Wardman stated that he was shortly proceeding to New York and would be visiting a number of amateur transmitting stations. He hoped to be able to broadcast on 20 metres for the benefit of listeners in this country, and would welcome reports. The Hon. Sec. is Mr. Jas. T. Webber, of 368, Brigstock Road, Thornton Heath.

NEWNES' TELEVISION AND SHORT-WAVE HANDBOOK

3/6 or 3/10 by post from
 GEORGE NEWNES, Ltd., 8-11, Southampton St., Strand, W.C.2.

New G.E.C. Radio Receiver for Schools

THE GENERAL ELECTRIC CO., LTD., has just introduced on the market a radio receiver which has been specially designed for use in schools and colleges, but which is equally suitable for installation in hotels, clubs, small hospitals, etc., when considerably greater volume is required than is usually obtainable from any "domestic" type of receiver.

The new receiver has a four-stage super-heterodyne circuit with two output pentodes in parallel—a combination which gives remarkably good response with adequate selectivity, together with ample volume to operate three or four loud-speakers if required. It is, moreover, a type of circuit which, though it makes quality of reproduction the primary consideration, is also capable of providing as wide a range of stations as can be relied upon for consistent entertainment at big volume.

Since the receiver is so designed as to be used as a central distribution point to loud-speakers and headphones in different parts of a building, no loud-speaker is embodied in the instrument itself. This is a point of design that is always desirable in the interest of high quality, even when the receiver is being used in the same room as the loud-speaker, because while the receiver will naturally be placed in the most convenient and accessible position for tuning and other adjustment, it is possible to situate the loud-speaker in a different part of the room specially chosen for its acoustic advantages. If the receiver is used solely for headphones, as many as 400 pairs can be connected to it.

The controls of the G.E.C. "Universal Superhet" are remarkably simple. All the principal stations are clearly marked on an illuminated dial, which is also calibrated in wavelengths, and tuning is accomplished simply by turning a pointer to the station-name, or the wavelength required. Another control adjusts the volume, and a third the tone, to the settings best suited to the listeners' needs, and the remaining control is used only to change from the medium to the long waveband.

Not the least of the advantages of this outstanding radio receiver is its adaptability, which enables it to work from any A.C. or D.C. supply between 200 and 250 volts, without any mains adjustment.

The approval of the "Universal Superhet" by The Central Council for School Broadcasting, as an instrument giving reproduction of sufficient realism to fit it for educational purposes, is a high tribute to the excellence of design and construction. The price of the receiver is £24, complete with Osram valves.

W. B. STENTORIAN SPEAKER COMPETITION.

Owing to the phenomenal number of entries which were received for this popular competition, it has been found impossible to publish the result on the date originally given. It will be appreciated that considerable work is involved in the judging of a competition of this nature, and the judges have found it impossible to arrive at the final decision yet. We hope, however, to give the full result, with names and addresses of the winners, in next week's issue.

ELECTRADIX BARGAINS

Phones. Phones. Phones. Phones.

TELEPHONES, House and Portable Inter-comm. and Telephones of various types cheap. Kindly specify wants. 120 ohm Sullivan Headphones, W.D. model. Aluminium body and headbands. Maker's price to-day, 15/-. Our price, 2/9 per pair. 3d. postage.



MICROPHONES. A Range of 25 Models to suit Every Purpose. 20 designs to select from, each suitable for its particular job. All tested in our own Lab. before despatch, and guaranteed. Complete mikes from 5/6. Send for special illustrated list "N."



CRYSTAL SETS.—Still the best Radio Receiver. No battery or valves wanted. Quiet and efficient reception. 500 shop-soiled sets cheap. Enclosed type, 7/6 and 10/6 each.



LEARN MORSE at Home with an ELECTRADIX SET. Contactor, Buzzer and Battery on Walnut base. Ready for use, 4/9. KEYS, 4/6, 7/6, 12/6, 18/6, 21/-.

WESTON TABLE TEST SETS in unused condition. Model 301, Moving Coil Weston Voltmeter 0-30 mounted flush in chromite panel on table brackets, space at back for cell, five terminals and test key. Three Guinea Bargain at 18/6 to clear.



THE SUPERSEDER. Makes H.T. from your L.T. 2-volt battery, rectified and smoothed. 3 tapplings. Lasts indefinitely. A boon. List £3 15s. New, guaranteed, 37/6.

Illustrated Bargain List "N" free.

ELECTRADIX RADIOS

218, Upper Thames St., London, E.C.4. 'Phone: Central 4011.

EASY TERMS

NEW 1936-1937 RADIO

FOR MORE THAN TEN YEARS we have SPECIALISED in the supply of all good quality RADIO SETS, COMPONENTS, VALVES and ACCESSORIES. SEND LIST OF YOUR REQUIREMENTS and we will supply keen quotation by return.



W.B. STENTORIAN SPEAKERS

These splendid Speakers are available on Easy Terms:— Cash price 32/6, or 2/6 with order and 11 monthly payments of 3/-. CABINET and EXTENSION SPEAKERS on similar terms. FULL LIST ON REQUEST.

Wharfedale, Goodman's & Rola Loudspeaker Units

Supplied on the best terms—Complete list sent free.

★ MCCARTHY CHASSIS ★

The remarkable New Model RFGAW ALL-WAVE CHASSIS—Cash price £8/10/-, or delivered for First Payment, £1/7/-, and 10 monthly payments of 16/-. Complete Price List available on request.

LATEST PICK-UPS, GRAMO-MOTORS & VALVES

All the newest products of well-known Makers supplied on the best of Easy Terms. WRITE FOR NEW VALVE LIST.

'Avomitor' Testing Meter

A most valuable instrument for tracing faults, etc. £2 cash, or 4/- with order, and 10 monthly payments of 4/-.

ELIMINATORS

All well-known makes supplied for FIRST PAYMENT of 5/-.

WE GUARANTEE SATISFACTION TO EVERY CUSTOMER. PROMPT DELIVERY. CASH or C.O.D. ORDERS SENT BY RETURN.

Estd. 1925 THE NATIONAL 1977

LONDON RADIO SUPPLY COMPANY

11 QAT LANE-NOBLE STREET-LONDON.E.C.2

What's the good of an all-wave set if interference isn't suppressed on the lower wavebands?

THE ALL-WAVE RECEIVER NEEDS ALL-WAVE SUPPRESSION

"ELIMINOISE"

The new all-wave

Anti-Interference Aerial
Effectual on all three wavebands: 10 to 50, 200 to 600, 1000 to 2000 metres, and without switching
NO DOUBLET CAN DO IT



Satisfactory signal strength even down to ten metres

Eight to ten receivers may be operated from one aerial without interaction.

As easy to erect as an ordinary aerial

No. 308. Complete Kit with one aerial, but without cable, 35/-

"C" Type Cable, No. 1221, 8d. per yard.

No. 307. Extra "Eliminoise" Transformers for additional receivers, each, 17/6.

Trade Mark

BELLING-LEE SUPPRESSION SERVICE

MAINS INTERFERENCE

No aerial system can protect a receiver from interference conducted to it via the mains. For complete suppression, you must filter the mains before they reach the receiver. Use this all-wave set lead suppressor—1-stage choke and condenser filter—to effect suppression close to receiver. A child can plug in.

No. 300: £11-wave, 1-amp. type is effectual down to 10 metres.



21/-

1211, Medium and Long Waves, 3-amp., 17/6

1256, Medium and Long Waves, 1-amp., 19/6.

Belling & Lee, Ltd., Cambridge Arterial Road, Enfield, Middx.

STRIKE OUT ITEMS NOT REQUIRED.

"Wireless Without Cracking" booklet, FREE.

"Eliminoise" folder, FREE.

"Interference Suppression" book; 1s. 2d. remittance enclosed.

Name

Address

Pr. W. 10.10.36

New Times Sales Co.

NEW TIMES SALES CO. was first with Easy Terms in 1924. We can supply all Radio Accessories, Kits, Sets, Pick-ups, Mains Units and Speakers on the lowest terms.

1937 STENTORIANS

ON EASIEST OF EASY TERMS

MODEL 37S. Amazing reproduction provided by new magnet and exponential moulded cone. Microdot matching device.

Cash or C.O.D. Carriage Paid, £2/2/0, or 2/6 down and 11 monthly payments of 4/-.

MODEL 37J. With the new exclusive Stentorian features. Wonderful improvement in volume and realism of reproduction.

Perfectly matches any receiver as principal or extra speaker.

Cash or C.O.D. Carriage Paid, £1/12/6, or 2/6 down and 11 monthly payments of 3/-.

Any W.B. Chassis or Cabinet Model available on attractive Easy Terms.

2/6 DOWN



RADIOGRAM CABINETS



Hand french polished, contrasting inlaid oak veneers, and attractive modern chromium fret surround.

LIST PRICE £3:3:0

BARGAIN

BRAND NEW **47/6**

Cash or C.O.D. (Carr. 2/8 extra) or 5/- down and 10 monthly payments of 5/- (inc. carr.)
Overall dimensions: 38 1/2" high, 22 1/2" wide, 17 1/2" deep.

Let us know your Radio needs and we will send "Easy Terms" quotation by return of post.

NEW TIMES SALES CO., 58 (Pr. W.18) Ludgate Hill, London. E.C.4.

BUILD YOUR OWN BATTERY CHARGER!

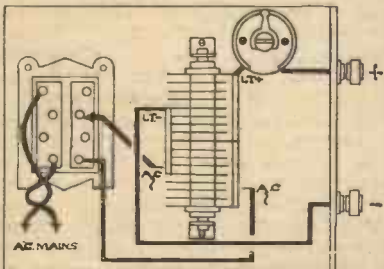

You can build your own battery charger from a HEAYBERD KIT OF PARTS in 30 minutes. Home charging is CHEAPER, it SAVES TIME, and it ensures that the accumulator is always WELL UP. These chargers incorporate METAL RECTIFIERS.

Set	Charges	Price
W.T.2	2, 4 or 6 volts at 1 amp.	30/6
W.T.4	2, 4, or 6 volts at 1 amp.	32/6
W.T.5	2, 10 or 12 volts at 1 amp.	41/-
W.T.6	2, 4 or 6 volts at 2 amps	54/6

Send NOW for List No. 988, describing HEAYBERD complete chargers and Kits of Parts.

F. C. HEAYBERD & Co., 10, FINSBURY STREET, LONDON - E.C.2.

FREE! RADIOGRAPHIC WONDER CATALOGUE.

EVERYTHING IN RADIO AT WORLD'S LOWEST PRICES. RADIOGRAPHIC LTD., 68, OSBORNE STREET, GLASGOW, C.I.

REPLIES IN BRIEF

The following replies to queries are given in abbreviated form either because of non-compliance with our rules, or because the point raised is not of general interest.

P. B. (Perivale). So far as we are aware there is no agent in this country. Write to the Loud-speaker Repair Works, 5, Balham Grove, London.

E. W. T. (Woodford Green). You may be using the coils in the wrong manner. Write direct to the makers for a detailed instruction sheet for the particular type of coil you have purchased.

K. W. (Upper Poppleton). The circuit may be badly arranged. Try the set with a battery first, and if the trouble still persists, use a resistance in place of the reaction choke.

T. R. (Erdington). For the medium waves wind fifty-four turns of 30 D.S.C. wire, and for the long waves wind three pile windings each of fifty-six turns of 36 D.S.C. Between these two sections include a forty turns coil of 36 D.S.C. for reaction.

J. O. (Ipswich). The coil is not standard but has to be re-wound to the instructions given in the article.

A. W. (Woodford Green). The circuit does not lend itself to conversion for short-wave work. A short-wave converter could, however, be used in conjunction with it.

S. J. P. (Enfield). We have no receiver answering to your specification and do not know where such a blueprint could be obtained. We may publish a similar design later on.

G. M. L. (Castleford). The connection referred to is, of course, an oversight and should be omitted in order not to short-circuit the anode load resistance.

H. B. (Liverpool, 6). Your idea would no doubt work. The holders should be mounted the same way round in order to provide coupling between the coils.

R. G. (Coventry). We cannot recommend a set to incorporate the parts mentioned.

J. C. L. (Edinburgh, 8). We have no details of the components and suggest you communicate direct with the General Electric Company, who manufactured them. Two 2-volt accumulators in series could be used for the valves in question.

T. J. (Cwmnach). Any good quality notepaper may be used, and Secotone or Durofix should be the adhesive. Shellac would be liable to crack.

H. L. (Chatham). With a suitable amplifier between the two speakers, and a suitable change-over switch, the arrangement should work quite satisfactorily. No screening should be required for the leads, but considerable amplification will be required.

A. O. (Mill Hill). A fair rise in temperature is generally experienced, but it should not be too hot to touch. The former may be obtained from Messrs. Peto-Scott or the British Ebonite Company, Ltd.

D. Mcl. (Durham). The set may not be working properly, and we suggest you communicate with the makers.

E. B. F. (Malvern Link). You could not use the parts from the set, but a short-wave adaptor (or converter) would be used in conjunction with it. Blueprint P.W. 48A described a suitable unit.

R. E. W. (Solihull). The arrangement mentioned by you is quite correct. It would be necessary, however, to add weight to the normal pick-up in order to prevent it from jumping and to assist in getting a good cut on the record.

L. K. (Glacton-on-Sea). The makers of your receiver will tell you the best method of fitting the 'phones, and you should not disconnect any leads until you have consulted them.

J. M. (Kidderminster). We do not recommend a change of the type referred to. Build a new set, or make a converter to use with the set. P.W. 48A shows a suitable unit.

R. F. B. (Hampstead). We suggest you try the receiver with a dry battery before attempting to alter the circuit. If the trouble still persists, it will be necessary to modify the H.F. section, either altering the position of the connection wires or totally screening this part of the set.

W. F. (Bucksburn). We regret that we cannot send blueprints or back numbers C.O.D.

V. B. M. (Cheltenham). The issue is out of print. The component parts are for an improved arrangement may be obtained from Messrs. Bulgin.

E. W. A. (East Ham). We cannot give the details in the form of a reply. We suggest you refer to back numbers in which various mains units have been described.

C. E. D. (New Malden). We have no details of the receiver which appeared before we took over *Amateur Wireless*. The back numbers of the issue are not available, and we suggest that you communicate with Messrs. Wright and Weaire concerning the coils.

I. L. M. (Sittingbourne). The trouble may be due to faulty wiring or a leaky condenser. Communicate with the manufacturers regarding an inspection of the set.

F. W. M. (Ide). The coils have been modified in the recent months, and we suggest you communicate with the makers regarding the type numbers.

S. J. P. (Enfield). If sufficient interest is shown by constructors we shall publish a mains version in the near future.

L. F. (Oldland Common). The blueprint is no longer available, and all issues describing the receiver are now out of print.

H. S. W. (Croydon). The change would no doubt prove worth while, but exceptional improvement should not be expected. No modifications are necessary if you obtain a 4-pin pentode. If you obtain a 7-pin valve the wiring will have to be modified.

THREE NEW RADIO BOOKS



INDISPENSABLE TO ALL

1936/37 CATALOGUE

Surpassing all previous issues it describes and illustrates the largest range of components in the world. British made quality products. Includes 100 entirely new components with technical data on all lines.

3d. EACH

RADIO SERVICE MANUAL Compiled by Service Experts essentially for every set owner. 64 pages, 240 pictures giving simple explanation of all working parts of a radio receiver.

1/- EACH

RADIO PROGRESS, NO. 2. A wonderful new edition. 49 pages fully illustrated. Describes ten of the world's most modern circuits for home construction. 9-valve A.C./D.C. Receiver. Car Radio Receiver. Symphonic Band Amplifier. A.C./D.C. Family Three. Modulated Oscillator. Three Valve A.C. Set. Quadband Super-set. All Wave Battery Super. Three Valve Battery Straight. 6-valve A.C./D.C. straight.

1/- EACH

BULGIN

To A. F. BULGIN & Co. Ltd., Abbey Road, Barking, Essex.
Please send post free Bulgin Catalogue, 3d., Radio Progress 1s., Service Manual 1s.
I enclose P.O. value

Name

Address

N. (Please use Block Letters.)

"In 'wireless' so called, it's strange
That good wiring effects such a change;
With FLUXITE," said Dad,
"I've made good what was bad,
And improved the reception and range."



See that FLUXITE is always by you—in the house—garage—workshop—wherever speedy soldering is needed. Used for 30 years in government works and by leading engineers and manufacturers. Of Ironmongers—in tin, 4d., 8d., 1/4 and 2/8. Ask to see the FLUXITE SMALL-SPACE SOLDERING SET—compact but substantial—complete with full instructions, 7/6. Write for Free Book on the art of "soft" soldering and ask for Leaflet on CASE-HARDENING STEEL and TEMPERING TOOLS with FLUXITE.

TO CYCLISTS! Your wheels will NOT keep round and true, unless the spokes are tied with the fine wire at the crossings AND SOLDERED. This makes a much stronger wheel. It's simple—with FLUXITE—but IMPORTANT.

THE FLUXITE GUN

is always ready to put Fluxite on the soldering job instantly. A little pressure places the right quantity on the right spot and one charging lasts for ages. Price 1/6.



ALL MECHANICS WILL HAVE
FLUXITE
IT SIMPLIFIES ALL SOLDERING
FLUXITE LTD. (Dept. W.P.) DRAGON WORKS, BERMONDSEY STREET, S.E.1.



QUERIES and ENQUIRIES

Background Noise

"I have a foreign seven-valve superhet. covering four wavebands. Although this is a highly efficient set and brings in practically anything, there is a terrible background noise the whole time, generally taking the form of a rushing noise upon which is superimposed a continuous faint crackling noise with occasional louder cracks. Is this a normal function of a powerful set or does it indicate some faulty valve or component? What is the best method, in the latter case, of tracing the faulty circuit?"—G. R. (Tring).

A RECEIVER of the type mentioned may be expected to be noisy unless special circuit arrangements are adopted. Apart from any risk of valve hiss and other internal circuit noises, the large H.F. amplification will result in all kinds of normal atmospheric disturbances being picked up, together with various noises generally referred to as man-made static. A special noise-free aerial system will only reduce the local interference, and when receiving a long-distance station some noisy background must be expected. A special noise-suppressing circuit may be built up, but is complicated so far as actual values are concerned, and may be difficult to introduce into the circuit. To trace for inter-circuit noises a good milliammeter is the best instrument to employ, and if this is included in each anode circuit in turn, any intermittent contact giving rise to the noise will reveal itself by a fluctuating needle, the fluctuations corresponding in movement to the noises.

Speaker Impedance

"I have a Stentorian 36M loudspeaker which I am thinking of using in place of my present speaker with my Lissen receiver. The output valve in this is a P.220A, and I am not certain whether the W.B. speaker will be suitable for this particular set. Can you advise me to use this speaker and if so, whether I shall have to get a transformer to match it."—D. R. (Blackpool).

WE presume that the output valve referred to is the Lissen valve, in which case the optimum load required is 8,000 ohms. The W.B. speaker you refer to may certainly be used in this case and the output terminals of your receiver should be joined to the 0 and 55 terminals on the speaker transformer. The speaker may be joined direct in the anode circuit if desired, as the total anode current of the valve in question is only 14 mA, and the transformer primary will carry 20 mA without difficulty.

Valve Functions

"I have heard and read a lot about Power valves and frequency-changing valves. Could you please inform me as to the exact work of these two types of valve. Why can't the signals be taken straight from the L.F. valve instead of putting a power valve in the circuit? In the case of the frequency-changing valve, what exactly is this form? I know it changes the frequency, but what

good do we get from that operation?"—A. L. (Brixton, S.W.).

IT is possible to feed the loudspeaker from an ordinary L.F. valve, or even direct from the detector. But the volume obtained would be small. After the detector, each successive stage will result in a larger output, and to handle that output each successive valve must have a larger grid swing. Thus, a power valve becomes necessary, and if taken to many stages, there will be no valve large enough to handle the swing and thus valves have to be connected in push-pull or parallel to take charge of the signal. In the case of the frequency changer the circuits are arranged so that the frequency of every

RULES

We wish to draw the reader's attention to the fact that the Queries Service is intended only for the solution of problems or difficulties arising from the construction of receivers described in our pages, from articles appearing in our pages, or on general wireless matters. We regret that we cannot, for obvious reasons—

- (1) Supply circuit diagrams of complete multi-valve receivers.
- (2) Suggest alterations or modifications of receivers described in our contemporaries.
- (3) Suggest alterations or modifications to commercial receivers.
- (4) Answer queries over the telephone.
- (5) Grant interviews to querists.

Please note also, that queries must be limited to two per reader, and all sketches and drawings which are sent to us should bear the name and address of the sender.

If a postal reply is desired, a stamped addressed envelope must be enclosed. Send your queries to the Editor, PRACTICAL AND AMATEUR WIRELESS, George Newnes, Ltd., 8-11, Southampton Street, Strand, London, W.C.2.

station which is received is converted to a common frequency. Thus all successive stages may be fixed-tuned and tuning and circuit design is thereby simplified. In the case of the modern superhet. the frequency of all stations is converted into either 110 kc/s or 465 kc/s and therefore one can have two or more I.F. stages, in each of which maximum gain may be employed, but no external tuning control is required.

Making H.F. Choke

"I am building the America 1 valve set (A.W., 429) and am doubtful about the construction of the H.F. Choke. If you can help me in this matter I shall be very grateful."—J. O. (Wainfleet).

THE choke in question was wound on a short glass tube (actually a chemical test tube). This should have a diameter of $\frac{1}{2}$ in., and is mounted on the baseboard by sticking the cork to it with any good adhesive. The winding consists of 255 turns of 36 d.s.c. wire, and to avoid counting these turns (which will be found very tedious due to the fine gauge of wire), a winding space of $2\frac{1}{2}$ ins. may be measured and the wire put on to fill this space. The ends of the winding are held in place by means of sealing wax, or similar material.

'Phone Connections

"Is it necessary to have a transformer when using headphones? I have been told that without one the 'phones become demagnetised. Is that true? What ratio transformer is required?"—D. T. C. (Fleet).

IN some circumstances it is certainly possible to ruin ordinary head-phones by passing through them a high current. In some types, however, if a small current is continually passed in a certain direction the magnets will be preserved. If your headphones have coloured tag ends, one will be indicated as positive, and this should be joined to the positive 'phone terminal of the receiver, with the other joined to the anode of the output valve. A more important point, however, is that a high current may burn out the windings of the headphone magnets, and thus the use of a transformer is a valuable safeguard. The ratio with ordinary types of valve may be 1/1, and this will suffice in your particular receiver.

H.T. Supply

"I notice in your issue of September 19th an article in which it is stated that H.T. may be obtained from the L.T. supply by means of a device now on the market. I have been desirous of getting such a device for some time, but cannot find any firm advertising a reliable article. I should be glad if you would tell me whether the device referred to is reliable and worth while, and also where and at what approximate cost such might be obtained."—D. H. P. (Reading).

A UNIT for the purpose mentioned is now manufactured by Messrs. Bulgin. The price of this unit is 20s. and the manufacturers state that it can be relied upon to have a working life of 1,500 hours or more. A special five-pin base is provided and the device is sound-proof and silent in use. It is designed for operation from a 6-volt D.C. source and will give a high-tension output up to 250 volts 60 mA. Full instructions and circuits are provided with the device. The necessary transformer for use with the device and a 6-volt supply costs 10s. 6d.

A Faulty Q.P.P. Stage

"I enclose a circuit of my output stage employing two pentodes in Q.P.P. I am disappointed with the quality which is not so good as when I was using one of the same valves singly. What worries me is the fact that I cannot get them to take more than 1.5 volts G.B. If I plug in to 3 volts the volume and quality suffer considerably. I have written to the makers of the valves and they give the bias as 4.5 to 6 volts. The H.T. supply is from a 1936 — Eliminator. There is one stage of H.F. (variable-mu pentode)."—N. A. W. (Redland, Bristol).

THE circuit as drawn by you is perfectly correct, and the input transformer is of the correct type. We note that the output transformer is embodied in the loud-speaker and the model named by you is quite suitable for the Q.P.P. circuit. Therefore, the fault must be due to the fact that the eliminator which you are using will not deliver sufficient current even for the two pentodes in a quiescent state. You must remember that on the arrival of a signal the anode current will fluctuate, and the peak values reached may be very much in excess of that delivered by your mains unit. Furthermore, the changes in voltage due to the changes in current will result in distortion in this particular type of apparatus unless you incorporate some device to even up the output. A special neon stabiliser is obtainable for the purpose from Messrs. Cossor, and this may be of use in your particular case, although we think that the rated output of your mains unit is too small for a Q.P.P. stage.

The coupon on page iii of cover must be attached to every query.

Miscellaneous Advertisements

Advertisements are accepted for these columns at the rate of 3d. per word. Words in black face and/or capitals are charged double this rate (minimum charge 3/- per paragraph). Display lines are charged at 6/- per line. All advertisements must be prepaid. All communications should be addressed to the Advertisement Manager, "Practical and Amateur Wireless," 8, Southampton Street, Strand, London.

RADIO CLEARANCE

63, HIGH HOLBORN, W.C.1:

TEL.: HOLBORN 4631.

The Mall Order House with World-Wide Reputation. Quality goods and satisfaction assured. ANNOUNCING GREATER BARGAINS THAN EVER IN GUARANTEED RADIO.

Price £8:19.6 PLESSY 6-VALVE ALL-WAVE A.C. RECEIVER, wave-range 15-2000 metres 9 1/2". Auditorium speaker. Provision for external speaker and pick-up. Handsome Walnut cabinet of modern design. Brand new. Made for export. To sell at 20 gns. EXCLUSIVE AMERICAN RIGHTS HELD BY US FOR CONSTRUCTRAD SHORT-WAVE KITS. All kits supplied valves free. Five interchangeable coils covering a range from 15-6000 metres. Complete set not a converter.

- 29/6 One-valve battery Kit.
37/6 Two-valve battery Kit.
37/6 One-valve A.C./D.C. Kit.
49/6 Two-valve A.C./D.C. Kit.

£5.19.6 EVER READY 5-VALVE BATTERY S/H. Incorporating A.V.C. large square-type dial, provision for pick-up and extension speaker. Listed 12 gns. Stocks are limited, order at once to avoid disappointment.

- 39/6 LISSEN 4-VALVE A.C. RECEIVER. Complete with valves. P.M. Moving-Coil speaker, handsome horizontal cabinet. S.G. Det. Pen. Rectifier.
70/- LISSEN 4-VALVE A.C. BAND PASS RECEIVER. A quality job listed at £9 15s. 0d. Sent out aerial tested, complete with valves.
55/- LISSEN BATTERY BAND PASS RECEIVER, complete with valves.
35/- LISSEN 3-VALVE PLUS BARRETTA D.C. RECEIVER. Fitted handsome horizontal Walnut Cabinet. Complete with valves.
35/- ALBA H.F. PEN, DETECTOR, PEN, 3 VALVE CHASSIS, brand new, fitted Mullard valves. AC/DC AMERICAN MIDGET, 5-valve type, a real quality job, Jensen moving coil speaker, etc., brand new, boxed.
75/- GRAMPIAN P.M. MOVING COIL SPEAKER, 7 1/2" cone, fitted in handsome Walnut cabinet of modern design, 10 range variable volume control Muilt transformer.

BRUCE MAINS TRANSFORMERS AND CHOKES, standard for the season, finest made, British and guaranteed.

- 8/6 250-0-250, 80 m.a., 2-0-2 volts, 2.5 amp., 2-0-2 volts, 4 amp.
10/6 350-0-350, 120 m.a., 2-0-2 volts, 2.5 amp., 2-0-2 volts, 4 amp.
12/6 350-0-350, 150 m.a., 2-0-2 volts, 2.5 amp., 2-0-2 volts, 4 amp.
17/6 500-0-500 volts, 150 m.a., 2-0-2 volts, 2.5 amp., 2-0-2 volts, 6 amp., 2-0-2 volts, 2 amp.
8/6 H.T.8 transformer, 250 volts, 60 m.a., 2-0-2 volts, 4 amp.
17/6 Ditto with H.T. 8 metal rectifier.

ALL TRANSFORMERS ARE FULLY SHROUDED. MAINS CHOKES.

- 4/6 40 m.a. 30 henrys.
6/- 60 m.a. 40 henrys.
10/6 150 m.a. 40 henrys.
21/- 250 m.a. 15 henrys.
6/- 60 m.a. 80 henrys, 2,500 ohms for speaker replacement, etc.
12/6 SPECIAL CLEARANCE CHOKE, 250 m.a. 12 henrys, 100 ohms heavy duty type, interleaved windings, etc. Cannot be repeated.
TRIAD AMERICAN VALVES, highest quality. All types 5/6 each as follows:
01-A, 24A, 27, 30, 31, 32, 33, 35, 37, 38, 39, 41, 43, 45, 46, 47, 53, 55, 56, 57, 58, 59, 71A, 75, 78, 80, 6AG, 1CG, 6FT, 2A3, 5z3, 12A7, 6A7, 6CG, 6DG, 12Z3, 25Z5.

ALL these valves carry a 90-day guarantee and free replacements provided that the filament or heater is intact and the glass is not broken when returned to us.

- 3/6 LISSEN CLASS B VALVES brand new, boxed.
7/6 SET OF 3 LISSEN BAND-PASS COILS, Iron core, screened, without switching, complete with circuit.

(Continued at top of column three)

PREMIER SUPPLY STORES

SHORT WAVES.

SHORT-WAVE COILS 4- to 6-pin types. 13-26, 22-47, 41-94, 78-170 metres, 1/9 each with circuit. Special set of 3 S.W. Coils, 14-150 metres, 4/- with circuit. Premier 3-band S.W. Coil, 11-25, 10-43, 58-86 metres. Simplifies S.W. receiver construction, suitable any type circuit, 2/- COIL FORMERS, in finest plastic materials, 1 1/2 in. low-loss ribbed, 4- or 6-pin, 1/- each. CONDENSERS, super ceramic S.L.F. .00016, .0001, 2/9 each; double-spaced .00015, .00025, .00055, 3/- each. All brass with integral slow-motion .00015 tuning, 3/9; .00015 reaction, 2/9 SHORT-WAVE KIT for 1 valve receiver or adaptor, complete with chassis, 3 coils 14-150 metres, condensers, circuit, and all parts, 12/6. VALVE GIVEN FREE. De Luxe Model, 17/6. 2-VALVE S.W. KIT, complete with valves, 19/6. 3-VALVE S.W. KIT, S.G., Det., and Pen. complete with valves, 40/- TELSEN iron-cored coils W.349, 4/- each.

PREMIER (Reiz Pattern) transverse current microphone 30/-; transformer 5/- SPEAKERS, MAGNAVOX. Mains energised. '154', 7" cone, 2,500 ohms 4 watts, 12/6. '154 Magna', 5 watts, 25/-; '152', 9" cone 2,500 ohms, 17/6; '152 Magna', 9" cone, 2,500 ohms, 0 watts, 37/6; Magnavox P.M.'s-'254', 7" cone, 16/8; '252', 9" cone, 22/6. Reliable P.M.'s, 10/6; Cossor P.M.'s, 13/6.

MAIN TRANSFORMERS. Premier wire-end M type with screened primaries. H.T.8 & 0 or H.T.10 with 4v. 4a C.T. and 4v. 1a C.T., 8/6. 250-250v. 60 m.a., 4v. 1a., 4v. 2a. and 4v. 4a., all C.T., 8/6. 350-350v. 120 m.a., 4v. 1a., 4v. 2a., and 4v. 4a., all C.T., 10/6. 500-500v. 150 m.a., 4v. 2-3a., 4v. 2-3a., 4v. 2-3a., 4v. 3-4a., all C.T., 19/6. Any of these transformers with engraved panel and N.P. terminals, 1/6 extra.

AUTO TRANSFORMERS, step up or down, 60 watts, 7/6, 100 watts, 10/-.

MAIN VALVES, famous Europa 4v. A.C. types, 4/6 each. H.L., L., S.G., Var-Mu-S.G., H.F. Pens., Var.-Mu-H.F. Pens., 1-, 3-, and 4-watt A.C. directly-heated output Pentodes. Full-wave rectifiers, 250 v. 60 m.a. A.C./D.C. types, 20-volt, .18 amp. S.G., Var.-Mu-S.G., H., H.L., and Power. Following types all 5/6 each. Full-wave rectifiers 350v. 120 m.a. and 500v. 120 m.a. 2 1/2 watt indirectly-heated Pentodes. Frequency Changers. Octodes and Heptodes.

BATTERY VALVES. 2-volts, H.F., L.F., 2/3. Power, Super-Power, 2/9. S.G., Var.-Mu-S.G., 4- or 6-pin Pentodes, H.F. Pens., V.-Mu-H.F. Pens., 5/- Class B, 3/6.

AMERICAN VALVES. Genuine American DUOTRON, all types, 3/6 each. Hytron super quality, 3 months' guarantee, all types, 5/6.

MILLIAMMETERS, moving-iron flush 2 1/2", all ranges from 0-10, 5/9. Visual tuning, 6 or 12 m.a., 5/-. Moving coil meters, 2 1/2" 0-1 m.a. 18/6; 3 1/2" 0-1 m.a., 22/6. Multipliers, 1/- each. Westinghouse meter rectifiers, 17/6 each.

ELECTROLYTICS. U.S.A. 4, 8 or 12 mfd. 530 v. peak, 1/9 each. Duobliier, 4 or 8 mfd. 500 v. 3/-; 50 mfd. 50 v., 1/9; 12 mfd. 20 v., 6d.; 25 mfd. 25 v., 1/-. T.C.C. 4 or 8 mfd. 650 v., 4/-; 15 mfd. 50 or 100 v., 1/-; 50 mfd. 12 v., 1/-. Paper Condensers. W.E., 250 v. working 4 mfd., 2/-; 2 mfd. 1/-. 1 mfd. 6d.; 250 v. working 4 mfd., 2/6. 2 mfd. 1/6. Duobliier 500 v. working 4 mfd., 4/-; 800 v. 4 mfd. 6/-; 2 mfd. 750 v. 3/-.

Wego 450 v. working 1 mfd. 1/-, 2 mfd. 1/9, 4 mfd. 3/-; 700v. working 2 mfd. 2/-, 4 mfd. 3/6; 1,650 v. working 1 mfd. 3/6.

TRANSFORMERS, latest type Telsen R.G.4 (list, 12/6), 2/9. Lissen Hypernik Q.P.P. (list 12/6), 3/6.

ELIMINATOR KITS for A.C. Mains. 120 v. 20 m.a., 150 v. 25 m.a., 10/-, tapped S.G. det. and output. Complete Kit with long-life valve rectifier (replacement cost only 2/-).

LISSEN ALL-ELECTRIC A.C.4. S. Grid. Det., L. Pen. and Rectifier, M.C. Speaker. (List £9.9.0). Our price 65/-.

Potentiometers by well-known makers. All values up to 1 meg. 2/-; with switch 2/6.

GRAMOPHONE MOTORS. Collaro, Gramophone Unit, consisting of A.C. motor, 100-250 v. high quality pick-up and volume control, 45/-; motor only 30/-; Collaro Universal Gramophone motor, 100-250 v. A.C./D.C., with high quality pick-up and volume control, 67/6; Universal Motor only, 49/6; Edison Bell double spring motors, including turntable and all fittings, 15/-; Cosmocord Gramo unit, comprising A.C. motor, pick-up and volume control (list 55/-), 35/9.

ALL POST ORDERS should be addressed to JUBILEE WORKS, 167, LOWER CLAPTON RD., LONDON, E.5.

'Phone Amherst 4723 (Private Branch Exchange). Callers, as usual, to 20-22, HIGH ST., CLAPHAM, S.W.4 (Macaulay 2381).

and 165 and 165a, Fleet St., E.C.4 (next to Anderton's Hotel). (Central 2833).

NOW READY! Send 4d. in stamps for NEW ILLUSTRATED GIANT CATALOGUE AND VALVE LIST.

(Continued from foot of column one) LISSEN R.C.C. UNITS.

- 9d. 8 mfd. AND 4 mfd. ELECTROLYTICS, 450 volt working, 500 volt peak, well-known make.
2/6 1 WATT WIRE END RESISTANCES, well-known make, all values.
6d. P.M. MOVING-COIL SPEAKER, 6in. CONE. By well-known manufacturer.
10/6 P.M. MOVING-COIL SPEAKER, 7in. CONE. By well-known manufacturer.
13/6 MULTI-PURPOSE VALVE suitable for H.F. Pentode. List 21s.
3/6 LISSEN 126 KC/S I.F. TRANSFORMER, fully screened.
2/- G.E.C. 110 KC/S I.F. TRANSFORMER, fully screened, midjet type with trimmers.
2/- TUBULAR CONDENSERS, wire end type, all sizes up to 1.
6d. LISSEN CENTRE TAPPED CHOKES. Brand new, boxed.
1/6 LISSEN INTER-VALVE CHOKES. Brand new, boxed.
3/11 UTILITY 3-GANG S/H CONDENSER. Comprising 2, .0005 sections, and 100 kc/s section. Fully screened with top trimmers.
5/11 MIDGET 2-GANG .0005 CONDENSER, fully screened, top trimmers. By well-known manufacturer.
2/6 DUPLEX AERIALS. Brush type. Supplied with 50 foot lead in and all fittings. Hours of Business, 9 a.m. to 7 p.m. Saturdays, 9 a.m. to 1 p.m. All orders value 5s. and over Post Free. Orders under 5s. must be accompanied by a reasonable amount for postage. Enquiries, 11d. stamp if reply expected.

RADIO CLEARANCE

63, HIGH HOLBORN, W.C.1.

TEL.: HOLBORN 4631.

RECEIVERS, COMPONENTS AND ACCESSORIES Surplus. Clearance, or Secondhand, etc.

- V AUXHALL.—Magnovox mains energised, 2,500 or 6,500 field coil, 10in. cone, 17/6; 7in. cone, 12/6.
V AUXHALL.—Magnavox permanent magnets, universal, suitable for Class "B" power or pentode, 7in. cone, 16/6; 10in. cone, 22/-.
V AUXHALL.—American Rolas energised 2,500, 8in. cone, 15/-; 9in., 19/6. Permanent magnets. 19/6 and 24/6.
V AUXHALL.—Above, fully guaranteed, complete with humbucking coils; state power or pentode transformer; unused manufacturers' stock.
V AUXHALL.—Polar Midget 3-gang condensers, straight or superhet, 8/9. Polar full vision, horizontal or Arcuate dial and drives, 4/6.
V AUXHALL.—Flat, sheet aluminium, hard rolled, 18 gauge, 12in. x 12in., 2/6; 18 x 18, 3/-; other sizes proportionate.
V AUXHALL.—Polar station named scales, for horizontal dials, latest settings; 1/0 each.
V AUXHALL.—Colvern Ferrocat iron cored coils, 2-gang, 20/-; 3-gang, 30/-; straight or superhet. Colpaks, 44/-.
V AUXHALL.—Volume controls, Erie, Colvern, Centralabs, 2/-; with switch, 3/-; all values, from 3,000 to 2 meg.
V AUXHALL.—T.C.C. electrolytic condensers, 8 mfd. and 4 mfd., 550 volt, 3/-; 600 volt, 2/6; 450 volt, 2/5; 200 mfd. 10-volt, 2/6.
V AUXHALL.—T.C.C. condensers, tubular, non-inductive, 0.1, 6d.; 50 mfd., 50v. working, 1/6; 50 mfd., 12v., 1/3; 0.05, 6d.; 0.002, 0.001, 0.0001, 4d. each.
V AUXHALL.—T.C.C. mica 0.002, 2,000 volt test, 1/-; 0.0001, 4d.; 0.001, 0.01, 1/-; 1 mfd. Mansbridge, 1/3; 2 mfd., 1/8.
V AUXHALL.—Resistances by well-known manufacturers, 1-watt type, 6d. each; all values.
V AUXHALL.—Centre tapped iron cored I.F. transformers, bases, terminals, 110 kc/s; 6/6 guaranteed.
V AUXHALL.—Set manufacturers' surplus, skeleton type Westinghouse rectifiers, H.T.8, 9/6; H.T.9, H.T.10, 10/-; complete with fixing brackets.
V AUXHALL.—Collaro 32 Model, 32/6; Universal model, 47/6; complete unit, A.C.200-250v., first quality pick-ups and volume control, 48/-.

V AUXHALL.—Utility slow motion dials, graded 150 to 1, marked in metres, 10/6.

V AUXHALL.—Hivac or Tungstam, valves, all types, for immediate delivery, fully guaranteed.
V AUXHALL.—Clix valve holders, terminals, 5-pin, 7d.; 9-pin, 9d.; baseboard mounting, 5-pin, 4 1/2d.; 7-pin, 1/-.
V AUXHALL.—Pushback wire, four colours, 6yds., 6d. 6BA screws or nuts, 4d. doz.
V AUXHALL.—Immediate delivery, carriage paid, lists free; cash with order or c.o.d.—Vauxhall Utilities, 163a, Strand, W.C.2 (Temple Bar 9338).

ALCO ELIMINATORS AND CHARGERS. 4 H.T. tap, 18/-; with 1/2 amp. charger, 25/- Charger alone, 7/6. 1/2 amp. 11/- Year's guarantee. Details free.—P. & D. Radio, 1, Gooding Lane, N.7.

GENEROUS ALLOWANCE made on second-hand receivers or components in exchange for any of the latest models. We have Ekco, Cossor, Marconi, Ultra, etc., in stock, and guarantee prompt delivery. Write to-day for quotation.—R. Wigfield, Edlington, Doncaster.

RECEIVERS, COMPONENTS AND ACCESSORIES Surplus, Clearance or Secondhand, etc.

BIRMINGHAM RADIOMART G5N1.—Everything a constructor requires, lowest prices, no junk; catalogue, 1/4d., shows thousands bargains; during summer few only shown below. RADIOMART. Huge purchase Cossor 1936. Super-ferrodyne receivers half price, £2/19/6. Stamp for full list. RADIOMART. Telsen screened dual range coils, 2/6. Pair 4/6. Milliammeters, 25ma. upwards, 5/9. Super, 6/9. RADIOMART. American mains transformers, 230 v. fully shrouded, 350/350. 6.3v., 5v., 6/11. Majestic 250/250. 2.5v, 5v, 4/11. RADIOMART. Heavy duty mains transformer worth 35/- 350/350. 150 ma.; 4v.2.5ACT., 4v0ACT., 12/6. RADIOMART, 465 kc/s., I.F., transformers, 2/11. B.T.H. speaker transformers, 2/11. Telsen Ace, 1/11. RG4, Radiograndis, 2/9. RADIOMART. Utility straight line wavelength dials, 3/11. Telsen H.F. chokes, 1/11. RADIOMART. Utility 2-gang miniknob and dial, 3/11; 1,500-volt tubular condensers, 6d.; Helsby electrolytics, 8 mf. 500, 2/11; 4 x 4 mf., 1/11; 25 mf. 25 volt, 1/-; etc. RADIOMART. Smoothing chokes, 20 hy. 120 m.a., 3/11; 100 m.a., 2/11; 40 m.a., 1/11. RADIOMART. Pushback wire, 6 yds. 6d.; heavy 9d.; 2 gross solder tags, 6d.; resin-cored solder, 9ft. 6d. RADIOMART. Centralab pots, all sizes, 1/6; switched, 2/-; tubular glass fuses, 2s. RADIOMART. Lissen 3-gang superhet kit coils, two L.F.'s, ganged condenser, ditto bandpass, ditto two-gang all-wave, 10/- kit. RADIOMART. Traders' monster bargain parcels, value £4/10/-, for 10/-; also 5/- parcels. RADIOMART. Famous Continental A.C. valves, 4/6; American Duotron, etc., all types, 3/6; battery from 2/3. RADIOMART. Utility 8/6, microdisc dials, 3/11; Radiophone, 0.00010 short-wave condensers, 3/6; series gap, twin, 3/9. RADIOMART. Ceramic all brass microvariable, 15 mmd., 1/4; 40 mmd. 1/7; 100 mmd., 1/10; short wave H.F.C., 6d. RADIOMART. Order 5/- post free; get our bargain catalogues; General 1/4d., Short wave 1/4d.—44, Holloway Head, Birmingham. Tel.: Mid 3254.

WE BUY for cash, all types of Modern Second-hand Radio Sets, Accessories, etc. Unbeatable Part-exchange allowances for new goods. Bring, send or write.

UNIVERSITY RADIO LTD., 82, Hampstead Road, London, N.W.1. Phone: Euston 3810.

CONVERSION UNITS for operating D.C. Receivers from A.C. Mains, improved type, 120 watts output, at £2/10/0. Send for our comprehensive list of speakers, Resistances and other components.

WARD, 46, Farrington Street, London, E.C.4. Telephone: Holborn 9703.

EXPERIMENTER'S Clearance. Sets, components, speakers, valves. Bargain prices. Lists.—Vowler, 81, Norfolk House Road, Streatham, S.W.10.

SOUTHERN RADIO'S WIRELESS BARGAINS. ALL GOODS GUARANTEED AND SENT POST PAID.

SPEAKERS.—Celestion Soundex Permanent Magnet, 10/-; Telsen Permanent Magnet with ten-tension transformer, 12/6; Blue Spot 90P.M. Extension Speaker, 20/-; 45P.M. Extension Speaker, 17/6; Telsen Loud Speaker Unit, 2/6; all new and boxed.

RECEIVERS.—G.E.C. A.C. D.C. Mains Three-valve R sets. Complete with 3 Osram Valves, in exquisite Bakelite cabinet with Osram M.C. Speaker. Ready to plug in to any mains. Fully guaranteed. New, in sealed cartons, £3/5 (list £7/15).

G.E.C. Compact 3-valve Battery Sets complete with 3 Osram valves, moving coil P.M. Speaker in attractive Bakelite cabinet, makers' 1936 series in original sealed carton, 50/- (list £5/10/0).

TELSEN A.C. D.C. MULTIMETERS (latest 1936 type).—5-range for every conceivable test for radio and domestic electrical appliances, 8/6 each.

COILS.—TELSEN (1936). Iron-cored Coils, Type W349, midget size, 4/-; type W478 (twin), 9/- pair; type W477 (triple), 16/-; type W476 (triple superhet selector and oscillator), 16/- set. All Ganged Coils are Mounted on Base with switch. I.F. Transformer Coils W482, 5/-; Telsen Dual Range Coil with variable series condenser W76, 4/-.

MICROPHONES.—Acc (P.O.) Microphones, complete with transformer, perfect with any type of receiver, 4/6.

TRU-OHM RESISTANCES.—1 Watt. Wire ends colour coded and marked; 36 assorted capacities on card, 6/-.

AMERICAN VALVES.—A full range of valves for all American sets at 7/- each. Brand new, guaranteed.

REPAIRS.—Any type of Receiver, American, British, etc. Repaired by Expert Staff.

SOUTHERN RADIO BRANCHES.—271/275, High Road, Willesden Green, N.W.10; 46, Lisle Street, W.C.2. All mail orders to 323, Euston Road, N.W.1.

SOUTHERN RADIO, 323, Euston Road, London, N.W.1 (near Warren Street Tube). Phone: Euston 3775.

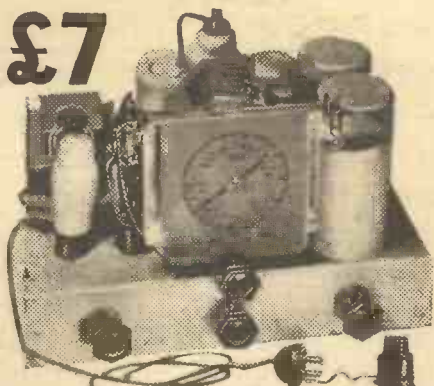

6 VALVE ALL-WAVE SUPERHET (Complete with B.V.A. Valves)

All-wave band-pass superheterodyne for A.C. or D.C. mains. High sensitivity on all three wave-bands (16.5-50 metres, 200-550 metres, 800-2,000 metres). Many interesting features, including:—Illuminated "Airplane" dial with station names. Special "squelch" valve for inter-station noise suppression, with manual muting control. Octode frequency changer. 8 stages, 7 tuned circuits. Position on switch connects pick-up terminals. Delayed A.V.C. 3.5 watts output. £7 cash complete with valves, knobs, pilot lamps, mains cable and plug, etc. Deferred terms from London Radio Supply Co., 11, Oat Lane, E.C.2. 12 months' guarantee. Suitable loudspeakers, cabinets, etc., in stock.

McCarthy Chassis from £4 5s. to £12. Write for illustrated catalogue.

MCCARTHY RADIO LTD. 44a, Westbourne Grove, London, W.2. Telephone: Bayswater 3201.

Advertisement for Radio as a Career. Features a book cover titled 'RADIO AS A CAREER' and the word 'FREE' in large letters. Text: 'Just write your name and address on a post-card, post it to us, and we will send you a free copy of "Radio as a Career" which tells you how you can become a qualified Radio Engineer and earn big money.' Below is 'TECHNICAL & COMMERCIAL RADIO COLLEGE FAIRFAX HOUSE (Pr. 74), HIGH HOLBORN, W.C.1.'

Advertisement for EDDYSTONE 1937 SHORT WAVE MANUAL. Features a book cover and the text: 'For SHORT WAVE Enthusiasts Get your copy early! Illustrated constructional articles for building simple S.W. battery sets; battery and A.O. mains superhet S.W. receivers with A.V.C.; Ultra S.W. Radio Telephone; Transceiver; S.W. Converters; Crystal-controlled Amateur Bands Transmitter, etc. From your Radio Dealer, W. H. Smith & Sons, or from Stratton & Co., Eddystone Works, Birmingham, 5, London service: Webb's, 14, Soho St., W.1.'

EDDYSTONE 1937 SHORT WAVE MANUAL

MISCELLANEOUS

WESTERN ELECTRIC Microphones, 1/6 each, post free; Transformers to match, 1/3; 500 clearance lines, catalogues 3d. each.—J. Bearfield, 195, Upper Street, London, N.1.

NEW RECEIVERS, COMPONENTS AND ACCESSORIES

HULBERT for Quality Surplus Speakers. All Music Lovers should write for List of amazing bargains. Prices from 8/6 brand new. Made by best known British maker.—Hulbert, 6, Conduit Street, W.1.

AMERICAN 7-Valve A.C. All-Wave. Magnavox Speaker. £13/0/0. List £17/0/0.

5 VALVE Freed-Eisemann A.C./D.C. Midget. Medium-Long. 92/6.

AS R MERICAN Valves. Popular Types. 7/- each. Guaranteed.

SATISFACTION Assured.

RADIO SUPPLIES, 74, Lowson Street, Darlington.

CLARION VALVES.—All brand new, battery types, 2-volt, H.2, H.L.2, L.P.2, 1/0; super power P2, 2/6; screens and L.F. pentodes, 3/0; A.C. mains, 4-volt, 1-amp, general purpose, 3/3; power, 4/-; screens and L.F. pentodes, 4/6; full wave rectifiers, 3/6; postage paid, cash with order, or C.O.D. over 10/-—Clarion Valves, Dept. 2, 885, Tyburn Road, Edington, Birmingham.

DANKRUPT Bargains. List free. All brand new goods. Telsen 6v. A.C. superhets, £5/10/0. G.E.C. Compact 3v. sets, M.C. and valves, 42/6. Lotus 4v. A.C./D.C. midgets M.C., 65/- Full stock Pilot, Ferguson, Truphonic all-wave receivers. Truphonic superhets, battery and mains types. Large stock components, replacement valves, moving coil speakers. Get my quotation before buying elsewhere. Keenest prices. Part exchange. Established since 1929.—Butlin, 6, Stanford Avenue, Brighton.

VALVES

VALVES. By well-known manufacturer. Complete range of Battery, A.C. Mains, Rectifiers, Brand new stock with six months' guarantee. 2-volt Detector, 2/3, Power, 2/0, Screen Grid, Pentode, H.F. Pentode, 5/-. The following American type valves, fully guaranteed, at 5/6 each: No. 80, 42, 43, 57, 58, 77, 78, 6C6, 6I6, 25Y5, 25Z5. Write for other prices to: Dale Electrical Co., Ltd., 7, Lizard Street, London, E.C.1.

LOUDSPEAKER REPAIRS

REPAIRS to Moving Coil Speakers, Cones and Coils fixed or rewound. Fields altered. Prices Quoted including Eliminators, Loud-speakers Repaired, 4/-. L.F. and Speech Transformers, 4/- post free. Trade invited. Guaranteed. Satisfaction. Prompt Service. Estimates Free. L. S. Repair Service, 5, Balham Grove, London, S.W.12. Battersea 1321.

SHORT WAVES

21/- B.T.C. SHORT-WAVE GUINEA KIT. Latest design for CONVERTER-ADAPTOR -ONE VALVE, 13 1/2 m. Excellent reception reports. Descriptive Leaflets P.G.K., 11d. stamp, including U.S.W. TELEVISION - CONVERTER Guinea KIT. BENNETT TELEVISION CO., REDHILL.

SHORT WAVE on a crystal set. Full building instruction and crystal, 1/2 post paid.—Radiomail, Tanworth-in-Arden, Warwickshire.

MISCELLANEOUS

YOUR Cigarette Lighter repaired. 1/6 includes return postage.—Sealing, 47, Abbey Road, Llandudno.

Advertisement for 'ENGINEERING OPPORTUNITIES FREE!'. Features a book cover titled 'ENGINEERING OPPORTUNITIES' and the text: 'This unique Hand-book shows the easy way to secure A.M.I.C.E., A.M.I.E.E., A.M.I.A.E.E., A.M.I.W.T., A.M.I.R.E., and similar qualifications. WE GUARANTEE—"NO PASS—NO FEE." Details are given of over 150 Diploma Courses in all branches of Civil, Mech., Elec., Motor, Aero, Radio and Television Engineering, Building, Government Employment, etc. Write for this enlightening Hand-book to-day FREE and post free. British Institute of Engineering Technology, 409, Shakespeare House, 17, 18, 19, Stratford Place, W.1.'

FREE ADVICE BUREAU COUPON

This coupon is available until October 17th, 1936, and must be attached to all letters containing queries. PRACTICAL AND AMATEUR WIRELESS, 10/10/36.

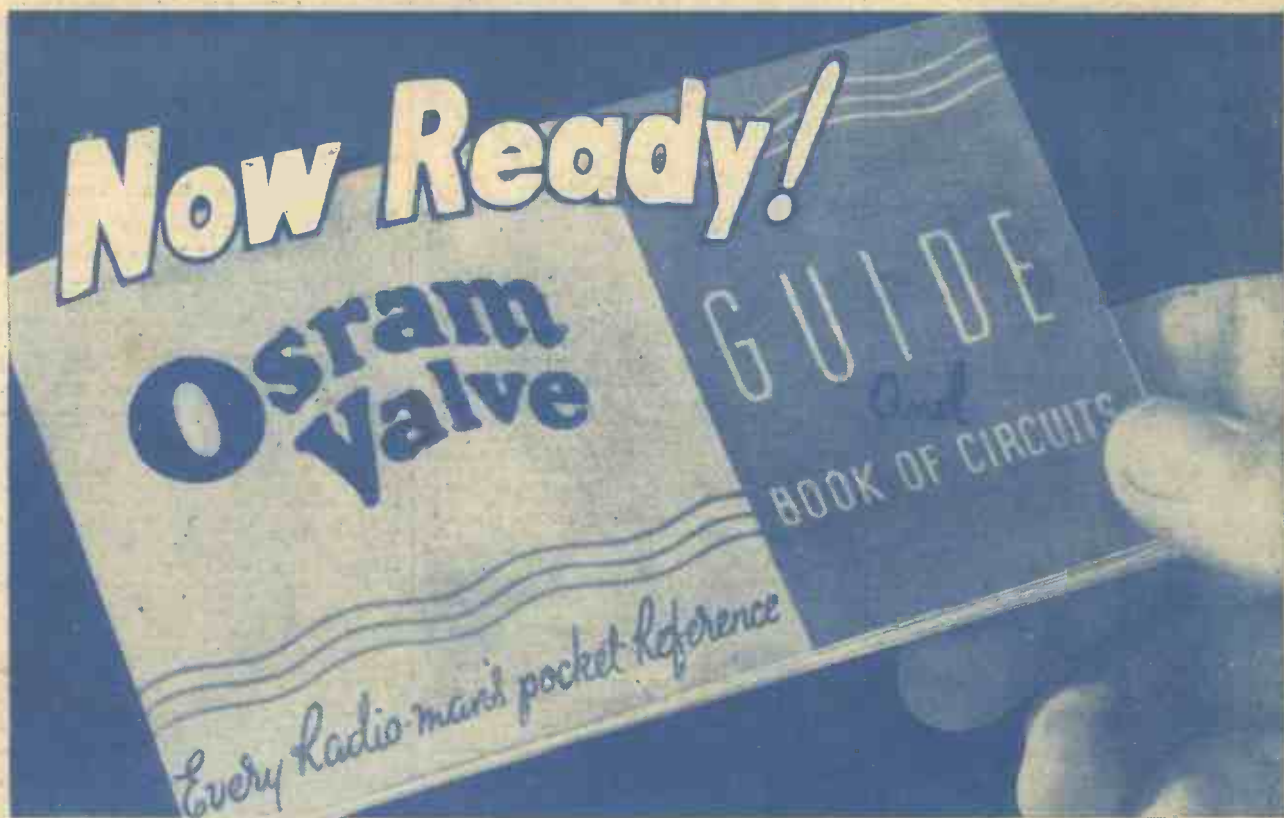

THE MOST COMPLETE *Pocket* REFERENCE YET COMPILED

This handy little guide will prove an invaluable aid to the radio listener and experimenter in all their valve problems. 64 pages giving comprehensive and up-to-the-minute information on Osram Valves, and working circuits. Convenient size to fit the pocket. Ask your local Radio dealer for a copy to-day!

The illustration above shows actual size of the OSRAM Valve guide.

Numerous interesting features include :

- Characteristics of all valves and working data
- Common Technical Terms relative to valves
- 16 Pages of Typical Operating Circuits
- Comparative Types
- Base-pin connections in diagrammatic form
- Complete Price List, etc.

Osram Valves

MADE IN ENGLAND

Write for your FREE copy without delay

LATEST TELEVISION NEWS

Practical and Amateur Wireless

3^D
EVERY
WEDNESDAY

Edited by F.J. CAMM

a GEORGE
NEWNES
Publication

Vol. 9. No. 213.
October 17th, 1936.

AND PRACTICAL TELEVISION



1 a
TELEVISION
CONVERTER

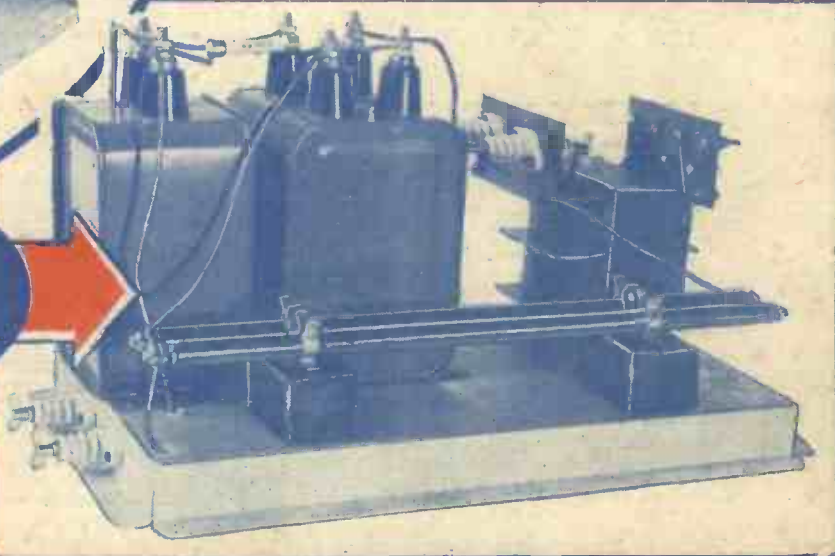

2
a
Power Pack
for
Television Tubes

EVERYMAN'S WIRELESS BOOK

By F. J. CAMM (Editor "Practical and Amateur Wireless," etc.)

A Radio Consultant for the Listener, Expert and Amateur Constructor, explaining the Operation, Upkeep and Overhaul of all Types of Wireless Receivers, with Special Chapters on the principles of Radio Telephony, Installation, and Systematic Fault-finding.

From all Booksellers only 3/6 net, or 3/9 post free from
GEORGE NEWNES, LIMITED, 8-11, Southampton St., Strand, LONDON, W.C.2.

With
200

Illustrations

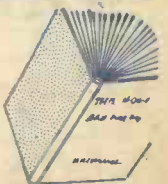

ADVT.



- VARIABLE-MU
PENTODE H.F.
-
- SCREENED H.F.
PENTODE DETECTOR
-
- SUPER-SELECTIVE
IRON-CORED COILS
-
- MOVING COIL
SPEAKER &c.
-

COSSOR

MELODY MAKER KITS

for BATTERY & A.C. MAINS

For utmost sensitivity—a Variable-Mu Pentode H.F. Stage; for interference-free listening—Super-Selective Coils; for extra amplification—a screened Pentode Detector, and for really superb reproduction—a fine Moving Coil Speaker . . . that is briefly the highly efficient Melody Maker Kit Receiver. And with the special constructional chart *anyone* can build it (battery or mains model) and so own a set which ordinarily would cost considerably more. Send for your chart today.

BATTERY MODEL 362

Complete Kit of parts including :-

Variable-mu H.F. Pentode, H.F. Pentode Detector, and Economy Pentode Output. Super-selective Iron-cored Coils. Single Knob Tuning. Wave-length calibrated scale. Combined On/Off, Wave-change and Pick-up Switch. Selectivity and Volume controls. 8 in. Moving Coil Speaker. Walnut finished cabinet 17½" x 13½" x 9½" accommodating all batteries. Terminals for Pick-up; plug and sockets for extension loud-speaker.

£5.5.0

(Less batteries)

H.P. Terms: 10/- deposit and 12 monthly payments of 10/-.

A.C. MAINS MODEL 361

Complete Kit of parts including :-

Variable-mu H.F. Pentode, Screened H.F. Pentode Detector, and Triode Power output. Heavy duty rectifier. Super-selective Iron-cored Coils. Single knob tuning. Illuminated scale, Wave-length calibrated. Combined On/Off, Wave-change and Pick-up Switch. Selectivity and Volume controls. 8 in. Energised Moving Coil Speaker. Walnut finished cabinet 17½" x 13½" x 9½". Terminals for Pick-up. Plug and sockets for extension speaker. A.C. Mains only. 200/250 volts (adjustable). 40-100 cycles.

£6.19.0

H.P. Terms: 12/6 deposit and 12 monthly payments of 12/6.

Prices do not apply in I.F.S.

THIS COUPON BRINGS CONSTRUCTIONAL CHART

To A. C. COSSOR, LTD.,

Please send me Constructional Chart which tells me how to assemble the Cossor Melody Maker, Model No.

Melody Dept., Highbury Grove, London, N.5.

Name.....

Address.....

(Please state model required.)

PRAO. 17/10/36

MAKING OSCILLATOR COILS — See Page 140.



Practical

and Amateur

Wireless

Edited by F. J. CAMM

Technical Staff:
W. J. Delaney, H. J. Barton Chapple, Wh. Sch.,
B.Sc., A.M.I.E.E., Frank Preston.



VOL. IX. No. 213. October 17th, 1936.

ROUND *the* WORLD of WIRELESS

Athlone Power Increase

IT is announced that towards the end of this month the power of the Athlone station will be increased. Since it first went "on the air" the power has been 60 kW, and the new power rating will be 100 kW. The estimated cost of the alterations to the transmitter is stated to be about £14,000.

H.M.V. Boom

AS a result of increased orders (no doubt due to the recent Radio Exhibition) the work and output at the Hayes factories of H.M.V. are being doubled. Day and night shifts are working to produce the new all-wave chassis for the new receivers and radiograms.

Increased Trade in India

AT a recent meeting of advertisers it was announced that great scope is offered

programme of one hour's duration will be presented nightly from the short-wave station VK3LR on 31.34 metres. The first programme is on Friday, October 16th, coinciding with the first day of the first match on Australian soil. The transmission is timed for the period 11.45 p.m. to 12.45 a.m. Australian Eastern Standard time (1.45 to 2.45 p.m. G.M.T.).

Large Tuning Dials

THE world's largest tuning dial, as fitted to a commercial home-receiving set, was seen at the last Berlin Radio Exhibition. This was fitted to a Telefunken "Radio Wagon" and occupied the entire width of the cabinet.

Television in Germany

IT is claimed in Germany that the problem of direct television has been solved. A new transmitter is being built and is to adopt a 375-line interlaced scanning system. No suitable receivers have, however, yet been designed.

A New Valve

A NEW standard valve has recently been introduced by the Western Electric Corporation of America which will oscillate at wavelengths as short as 40 cms. At half a metre it can generate an output of 6 watts.

Free Television Demonstrations

THE present test transmissions of television may be seen free of charge at various places in the London area. At Waterloo Station Baird receivers are installed and may be seen by anyone holding a railway ticket. At the Science Museum, Kensington, a Cossor receiver is installed and is used to pick up the daily transmissions, whilst a similar receiver is in use at the Brent Bridge Hotel, Hendon, in the Brasserie.

New Time Signal Service

THE new Six Pips Time Signal Service, which was inaugurated on October 4th, radiates at 10.30 a.m., 4.0 p.m. and 9.0 p.m. from Droitwich, and at 4.0 p.m. and 9.0 p.m. from the Regional transmitters on Sundays. On weekdays the signal will be radiated from Droitwich at 10.30 a.m., 2.0 p.m., 6.0 p.m., 9.0 p.m. and 11.30 p.m., and from the Regional transmitters at 10.30 a.m., 2.0 p.m., 7.0 p.m., 10.0 p.m. and 11.30 p.m. The signals at 10.30 a.m. and 6.0 p.m. will be only suppressed in exceptional circumstances, but all other signals may be suppressed if superimposition on a current programme is inadvisable on artistic grounds. Big Ben will, of course, be additional to these signals.

ON OTHER PAGES

	Page
The Pick of the Programmes	126
Automatic Record Changers	127
Readers' Wrinkles ..	129
Our Competition Result ..	130
Thermion	131
A.B.C. of the Modern Receiver	133
Practical Television ..	135
New Season's Sets	137
Making an Output Meter ..	138
Making Oscillator Coils ..	140
Short-Wave Section ..	143
Impressions on the Wax ..	147
Practical Letters	149
Queries and Enquiries ..	151

Television Utility

THE recent parade of new cars on the Television service gives a good idea of the practical utility which this service may have in the future. No doubt the idea will be extended as the technique of the television transmission service improves.

The Irish Mail in Cape Town

IT is announced from Cape Town that the recent relay of the Irish Mail running from Holyhead to London was well received. A particular part of the transmission dealt with the automatic picking-up and dropping of the mail bags and the roar and whistle of the train were plainly heard in Cape Town.

THE PICK of the PROGRAMMES

Farewell Summer

THE North Regional season of "Summer Outside Broadcasts" from the seaside comes to a close this month, and on October 16th there will be a special farewell programme from Blackpool. This will be provided by the Arcadian Follies, broadcasting from the South Pier, and Larry Brennan and his Band from the Winter Gardens Ballroom; there will also be a variety act from the Palace Theatre.

MAKE THESE DATES
WITH YOUR RADIO

tunity of listening to radio Music Hall, it has been decided as an experiment to broadcast this popular programme occasionally from 9.20 to 10.20 p.m. The first of these late transmissions was given in the National programme on October 10th.

TELEVISION FOR HOTEL PATRONS.



The first Cossor television receiver being carried into the Brent Bridge Hotel, the first to offer television as an additional attraction for its patrons. Note the cathode-ray tube in the hands of the hotel attendants.

Light Entertainment

ON October 17th, from the Western Regional, a programme of light entertainment will be broadcast when the Phantom Five (directed by Edgar Hawke), Eric Goldie (baritone), and Mary and Michael (singing songs by Michael Sayer) will be the artists.

Drama for Sunday Programmes

LISTENERS will be pleased to hear that the B.B.C. Drama Director has arranged to produce Carol Goodner in Norman Edward's "The Queen of Baltimore" on Sunday, October 25th.

"The Lady of the Lamp"

THE services of that popular actress, Diana Wynyard, have again been secured by Val Gielgud for the play "The Lady of the Lamp," which will be broadcast in the National programme on October 19th, and from the Regional on the following day.

New Rhythm Orchestra

VAN PHILLIPS will conduct his new rhythm orchestra for the first time for listeners on October 18th in the National programme. Actually the orchestra will be divisible into two parts—the full orchestra of twenty players playing modern dance numbers, and a small string orchestra playing the favourites of yesterday.

Music Hall

IN order to give listeners who have to work late on Saturdays, or are obliged to do their shopping in the evening, an oppor-

The Gunpowder Plot

LISTENERS to the National programme on November 5 will have a thrilling reminder of the famous plot, when a feature programme devoted to what fortunately proved to be the best-known damp squib on record will be presented.

Organ Recitals

BERKELEY MASON will give an organ recital on October 19th in the National programme, and Harold Darke will give another one on October 23rd in the Regional programme.

Guitar Recital

A WELCOME return to the microphone for many listeners will be that of the famous Spanish exponent of the guitar, Segovia, who will give a recital in the National programme on October 19th.

Symphony Concerts

THE first of the Wednesday Symphony Concerts at the Queen's Hall will take place on October 21st. Adrian Boult will conduct, and José Iturbi will be the soloist in Mozart's Concerto No. 20, in D minor, for pianoforte and orchestra. The other items in the programme are Beethoven's Overture, Leonora No. 2, and Vaughan Williams' "A Sea Symphony," which will be sung by Noel Eadie, William Parsons, and the B.B.C. Choral Society.

Musical Comedy Programme

ON October 20th, from the Midland Regional, Reginald Burston will conduct the Revue Orchestra, led by Norris

Stanley, in a programme entitled "Melodies from the Comedies." The vocalist is Alex Penney, the Derby soprano.

Munn and Felton's Band

A PROGRAMME of operatic music will be played on October 18th by this Kettering Band, which won the Crystal Palace Championship last winter. George Gibbs, the Wolverhampton baritone, will be the vocalist.

Schubert Programme

MIRIAM LICETTE, the famous operatic soprano, will be the vocalist with the Birmingham Ladies' String Quartet in a Schubert programme on October 23rd. The instrumental works to be given are the G minor and C minor Quartets.

Concert from Torquay

JAN VAN DER GUCHT (tenor) will be the artist in the concert by the Torquay Municipal Orchestra, conducted by Ernest W. Goss, to be broadcast from the Pavilion, Torquay, on October 20th.

Royal Marines Band

A CONCERT by the Band of His Majesty's Royal Marines, Plymouth Division, conducted by Captain F. J. Ricketts, is to be broadcast from the Abbey Hall, Plymouth, on October 22nd. Frederick Harvey (baritone) will be the vocalist.

"La Bohème"

ACT I of "La Bohème," by Puccini, performed by the Royal Carl Rosa Opera Company, will be broadcast from the Empire Theatre, Swansea, on October 19th. The principal parts will be taken by Ivor John and Howell Glynne.

SOLVE THIS!

Automatic Record Changers

A Review of Some of the More Popular Types of Automatic Gramophone Record Changer which are Available for the Home Constructor

By W. J. DELANEY

PRACTICALLY every listener now requires a radio-gram, even if this consists of a simple table model radio receiver, with a gramophone pick-up plugged into it and operating from a clock-work motor which has been dismantled from a cheap portable gramophone. The reason for the increased popularity of the

now on the market costing only £7 10s. Of course, mains facilities must be available, as the motor which rotates the turntable also operates the changing mechanism. One of the most popular instruments of this type is the Collaro A.C. Model, costing £10. This apparatus accommodates eight records which must all be of the same size, either 10in. or 12in. The centre spindle of the turntable is much higher than on a standard instrument and the records are supported at three points about 4in. above the turntable. When the apparatus is set into action the turntable rotates, the pick-up rises from the position of rest and is gently lowered on the first groove. When the record is finished the pick-up is raised an inch or so, travels back to a

the process is repeated until the last record has been played, whereupon the pick-up travels to the "rest" position and the apparatus is automatically switched off. Special controls are available to regulate the speed of the turntable and to enable a record to be repeated *ad lib* or to be

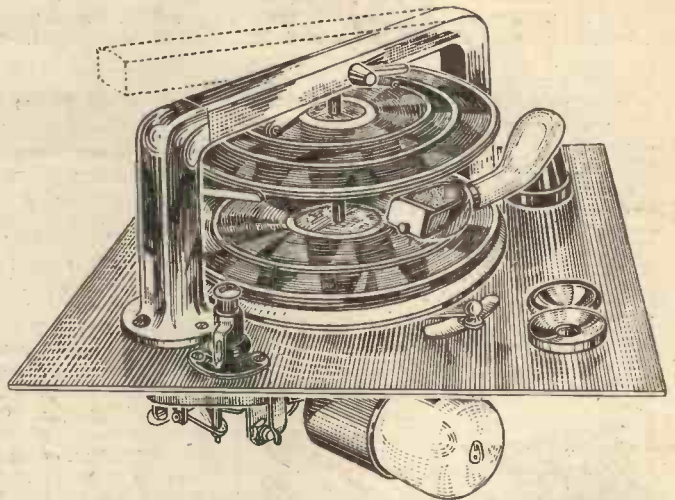

Fig. 1.—The Garrard Ten Guinea Auto Changer which accommodates mixed sizes of records.

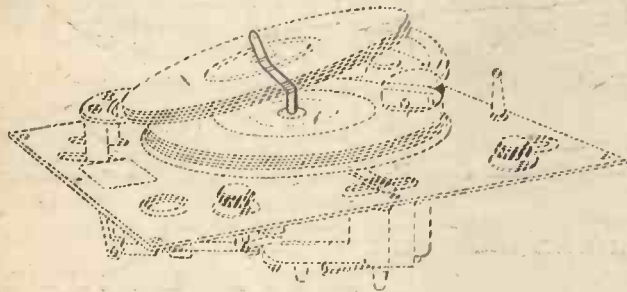

Fig. 2.—This is the cheapest changer—Collaro Model R.C.4, costing £7 10s.

gramophone is not far to seek. The many new entertainers who have appeared over the air, and the increased amount of music which is now available have resulted in every listener acquiring a greater interest, and when the favourite artist is not "on the air," or when one desires to hear a particular item, the gramophone record may be employed. The item or artist is always available, and when the radio amplifier is well designed, the reproduction from the record will be as perfect as the radio reproduction. Indeed, in certain cases the reproduction from a gramophone record may be made to excel that obtained from the radio. The main requirements for gramophone record reproduction are a pick-up and a turntable, but although this simple apparatus will suffice, the enjoyment may be increased a hundred times if an automatic record changer is employed. For instance, in the reproduction of an opera, or a musical comedy, which is available on a series of records, when an automatic changer is employed one may stack the records on the apparatus, set the switch and then sit back and enjoy the complete programme, without the distraction of getting up every few minutes to take off the old record and place on the new.

position just beyond the edge of the record, and the lower record of the pile is released, to fall upon the one just played. The pick-up then travels to the starting position and

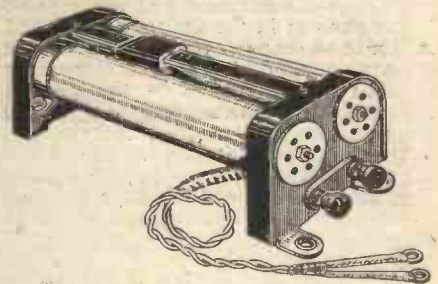

Fig. 3.—For use with the Garrard Universal Changer this resistance unit will enable any voltage mains to be employed.

rejected in the event of it being an unwanted one. Model R.C.4 is a cheaper edition of the Collaro changer, and is illustrated on the left of this page.

Types of Changer

This type of equipment is now comparatively cheap, the lowest priced item

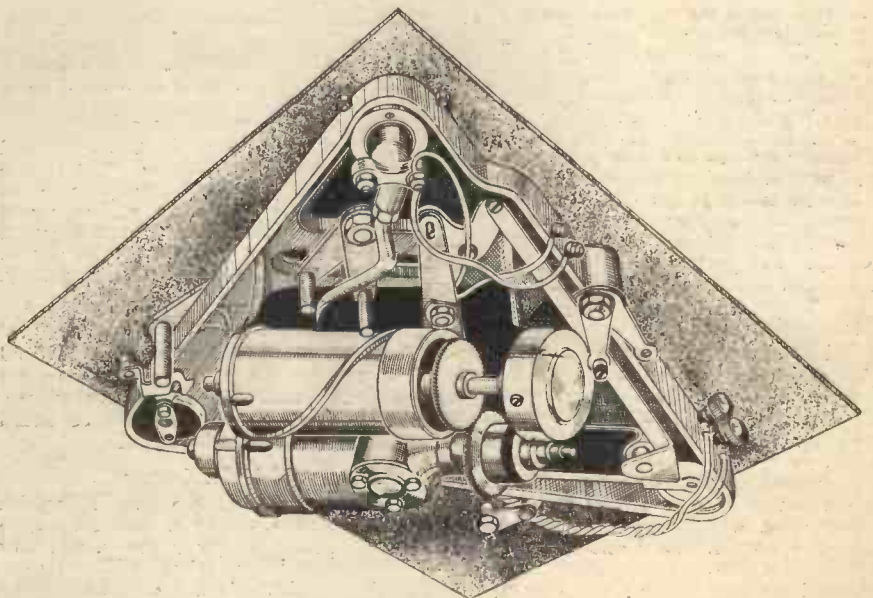

Fig. 4.—An underside view of the Collaro Changer, showing the operating mechanism.

This also accommodates eight records but the releasing mechanism is slightly different. The central spindle is bent in a certain manner, and when the pile of records is tipped the lower one will slide over the bend and drop to the playing position. In other respects this apparatus is similar to the first mentioned, and rejects or repeats are obtainable. The price is £7 10s.

Garrard Changers

The Garrard changer shown on page 127 possesses the advantages that records may

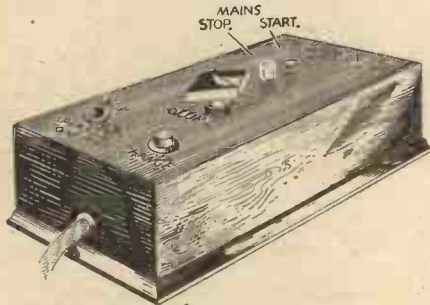

Fig. 5.—The Autrotrope Control Unit.

be "mixed," that is, 12in., 10in., 9in., and so on may be placed haphazard, and each will be released in its turn. In this equipment the movement of the pick-up is the same as in the Collaro models, and in fact in all changers the same movements are carried out during the working of the apparatus. The records in the Garrard changer are, however, supported only on two sides, and two fingers project from the sides of the uprights seen in Fig. 1. The records are placed upon the turntable by unlocking the cross piece of the changer and swinging it to one side. When replaced the stack of records is lifted until gripped by the mechanism, when the switch may be put to the "on" position and the apparatus set into action. In this model a single knob is provided, but it effects the four actions—start, repeat, reject and stop.

To enable the Universal model to be used on any mains a special mains resistance is available and is shown in Fig. 3. This enables the Universal model changer to be used on either A.C. or D.C. mains having

voltages between 100 and 250. A slider is provided for adjustment purposes. The Garrard changer which is illustrated costs £10 10s.

Post-Box Changer

Although not strictly a changer in the respect that various records are played in a prearranged order, the novel device shown in Fig. 6 must be mentioned in this article. It is a complete unit which takes a record and places it upon the turntable, and when played pushes it back to the position from whence it came. It is used in a cabinet shown inset in this illustration, and this avoids the necessity of opening and closing a lid, thus making a more compact radiogram. The record is pushed into the slot, where the mechanism takes charge and delivers it at the conclusion of playing. The movement is accomplished by the left-hand arm seen with its contact resting upon the turntable. The chassis may be obtained for £6 18s. 6d. (A.C.), and the complete cabinet model costs £8 17s. 6d. Universal models are available at slightly increased cost. All the units so far described are built complete on a plate with every control and it is only necessary when fitting these to cut the necessary clearances in the motor-board and the entire apparatus may be dropped into position and screwed down. Generally, the operation of installation should not take half an hour.

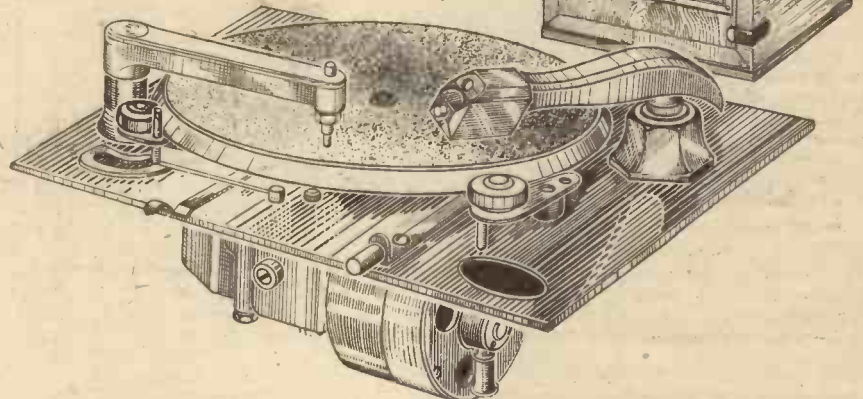

Fig. 6.—A novel piece of apparatus from the Collaro range. This is the Post-Box Unit, and a cabinet model is shown inset.

The Autrotrope

This article would not be complete without mention of the ingenious Autrotrope changing apparatus. This accommodates from 1 to 33 records, either 10in. or 12in., mixed or all of the same size, and the apparatus not only changes from one record to the next, but also turns them over, and both sides may be played consecutively or one side only as desired. This is in addition to the usual repeat or reject controls. Separate motors are employed for rotating the turntable and changing the records, and the movements are carried out smoothly without risk of damage to the records. An arm takes the record from the magazine in which they are stored, places it upon the turntable, and fingers gripping the side of the record turn it over. When played it is carried gently to the side and delivered on its edge on to rubber buffers. Unfortunately, this mechanism is not available for the home constructor and is only embodied in the radio-grams manufactured by the Self-Changing Gramophone Company.

Govan Burgh Band

EARLY on October 23rd the Goyan Burgh Band, conducted by Gregor J. Grant, will play the Overture "La Gazza Ladra," by Rossini; "Slavonic Rhapsody" No. 2, by Friedemann, and a Scottish Phantasy by the conductor. George Kerr will play a trombone novelty, "Ecosse," and inset in the programme will be a little drama for two women entitled "The Wedding Ring," written by Andrew P. Wilson. The parts will be played by Meg Buchanan and Jean Taylor Smith.

Star-gazing

ON October 22nd, in the National programme, Leslie Baily and Charles Brewer will inaugurate a new series of radio programmes to alternate with their now famous "Scrapbooks." This new series is "Star-gazing." In each programme a theatrical celebrity will come to the microphone and thread together the outstanding incidents of his or her career from the moment that a certain something entered his blood and destiny spelt the word t-h-e-a-t-r-e before him. The subject of the first programme is that popular actor, Robert Hale.

PROGRAMME NOTES

A Programme of Rhapsodies

FOR the concert by the B.B.C. Midland Orchestra on October 22nd Leslie Heward has chosen a programme of rhapsodies from France, Spain, Russia, and Hungary and Somerset. The last-named was composed by the late Gustav Holst, who lived in the neighbouring county, Gloucester.

Edith Penville

AS the principal flautist with Midland associations, Edith Penville has given recitals at Birmingham on several occasions, and on October 21st she will be heard again in the Midland programme.

B.B.C. Scottish Orchestra

ON October 22nd the B.B.C. Scottish Orchestra, led by J. Moulard Begbie and conducted by Guy Warrack, will play the Overture "Der Freischütz," by Weber, the Scènes Hongroises, "Entrée en forme de danse," "Intermède," "Adieux de la fiancée," "Cortège," "Benediction Nup-

tiale," "Sortie de l'Eglise," by Massenet; the Overture to "Die Fledermaus," by Strauss; while Winifred Osborne (contralto) will sing with orchestra "O Love, from thy Power," from "Samson and Delilah," by Saint-Saëns; "When all was Young," from "Faust," and "The Flower Song," also from "Faust," by Gounod. Later in the programme Miss Osborne will sing "Lament of Isis," by Bantock; "I Love Thee," by Grieg; "Care Selve," by Handel, and "Elégie," by Massenet.

Chamber Music

ON October 18th (Regional) Ethel Bartlett and Rae Robertson will give a recital of music for two pianos. On the same day (Regional) there will be the first concert of the third series of Special Recitals, at which the Stratton String Quartet will play examples of string quartets before Haydn.

Northern Revue Orchestra

This popular orchestra, conducted by Thomas Matthews, will broadcast another "Swing Low, Sweet Music" concert in the Northern programme on October 19.

A PAGE OF PRACTICAL HINTS

SUBMIT YOUR IDEA

READERS WRINKLES

THE HALF-GUINEA PAGE

A Valve-cap Repair

IN removing the cap on the screen terminal of a Marconi AC SGVM Valve, the thimble came away from the valve. It

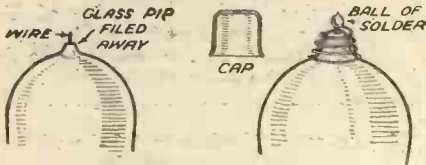

A simple but effective valve-cap repair.

was a brand new valve, and I did not want to scrap it. I filed and chipped the glass pip on the end of valve till about 1-16th in. of wire projected. I then melted a bead of solder on a piece of wood, held the valve on the solder till the latter cooled. I next wound a piece of light copper wire round the base of pip, bringing one end over the bead and soldering the wire to the bead. The end of the wire is brought out through the thimble, and soldered to it on top.—**J. WATT (Dublin).**

A Useful Addition to Low-Tension Switches

THE accompanying pictorial sketch shows a compact and very useful adjunct to a low-tension (on-off) switch. A flanged bracket of 3-64in. mild steel is held at the rear of the panel by means of

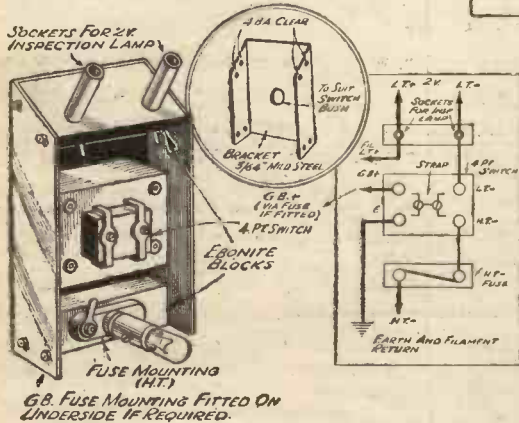

A useful addition to a low-tension "on-off" switch.

the switch-fixing bush—the lower portion holds an insulation block carrying the required number of fuses. Two sockets are mounted, at a convenient angle, upon another block at the top of the bracket to enable the plugs associated with a 2-volt inspection lamp to be inserted. In the appended wiring diagram it will be noticed that the low-tension supply for the lamp is always available, irrespective of the position of the switch, and, moreover, the fitment facilitates access to the fuses and requires very little additional space.—**W. A. HARRISON (Aintrec).**

THAT DODGE OF YOURS!

Every Reader of "PRACTICAL AND AMATEUR WIRELESS" must have originated some little dodge which would interest other readers. Why not pass it on to us? We pay £1-10-0 for the best wrinkle submitted, and for every other item published on this page we will pay half-a-guinea. Turn that idea of yours to account by sending it in to us addressed to the Editor, "PRACTICAL AND AMATEUR WIRELESS," George Newnes, Ltd., 8-11, Southampton Street, Strand, W.C.2. Put your name and address on every item. Please note that every notion sent in must be original. Mark envelopes "Radio Wrinkles." Do NOT enclose Queries with your Wrinkle.

A Band-spread Condenser or Aerial Coupler

TO make this band-spread condenser, take to pieces a pre-set condenser, and remove the plates with the exception of two. The spring plate, making contact with the

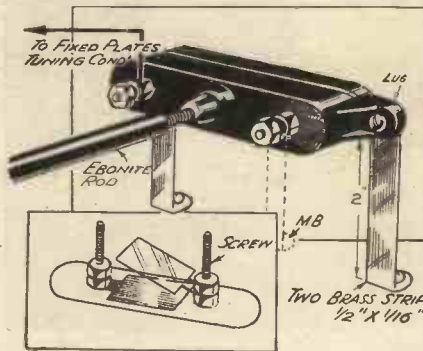

A method of making a band-spread condenser.

screw, and one piece of mica covering the bottom plate should be left in, as shown in the accompanying sketch. The condenser is reassembled, the small screwdriver head removed from the contact screw, and an ebonite rod drilled to take its place, and also to serve as an extension handle. If a metallised baseboard is used, a brass strip could be mounted under one of the terminals, as shown by dotted lines, the other terminal being connected to fixed plate of main condenser.—**G. KENYON (Blackburn).**

A Novel Soldering-iron Rest

THE soldering-iron rest shown in the accompanying sketch is easily contrived with an old loudspeaker magnet, which is held in place with a bracket bent

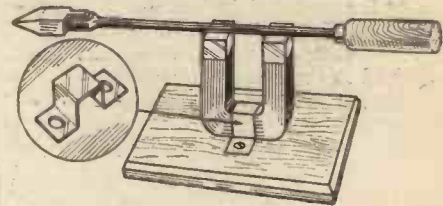

Using an old loudspeaker magnet for a soldering-iron rest.

to shape from a strip of tinplate. The whole is assembled on a baseboard measuring 4in. by 3in. by 3/4in. The advantage of this rest is that the iron cannot roll off.—**A. EKIN (Barnsley).**

A Dual-purpose Switch

THIS useful switching arrangement functions as follows: When the switch knob is pushed in, the two brushes shown at the top of the sketch short on the brass nut, thus connecting the aerial direct to earth. At the same time the low-tension supply is broken, thereby switching the set out of action.

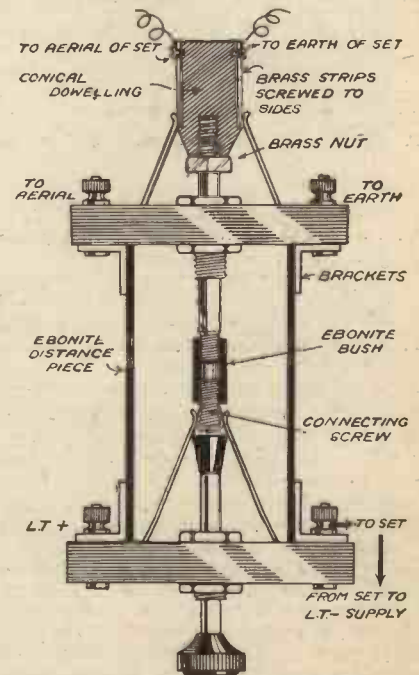

Modifying a push-pull switch for controlling the aerial, earth and L.T. supply.

When the switch is pulled out, the two brushes make contact with each of their brass strips respectively, thus connecting the aerial and earth to the set.—**T. HATCHER (Shorcham).**

NEWNES' TELEVISION AND SHORT-WAVE HANDBOOK

2nd Edition

By **F. J. CAMM.**

Price 3/6 or 3/10 by post from the Publishing Dept., Geo. Newnes, Ltd., 8-11, Southampton St., Strand, London, W.C.2.

Our Radiolympia Competition Result

What are the Most Important Points in Connection With a Speaker?

AS announced in last week's issue, we now give the result of this popular competition, the entries being judged in the following manner:—

(1) **SCORING**:—The figures on each coupon from 1 to 6 were placed against the respective items and added up. This gave each item a total score. The most popular item was naturally the one with the lowest

The names and addresses of the successful competitors are as follows:—

A. G. EVANS, Tumble Hotel, Tumble, Nr. Llanelly, S. Wales.
 W. J. COLCLOUGH, 31, Lancaster Gardens, Ealing, W.13.
 K. CUNNINGHAM, King's Hill, Bude, Cornwall.
 J. F. BARLOW, 3, Franklin Street, Exeter, Devon.
 H. CLOUGH, 50, High Street, Knarlesborough, Yorks.
 J. D. ALDRED, 56, Foxley Lane, Purley.
 B. ARNOLD, 20, Westbury Road, Croydon, Surrey.
 R. A. BATES, 49, Croft Avenue, South Shields, Co. Durham.
 C. F. CLAYDON, R.E. Drill Hall, Bright Street, Middlesbrough.
 D. MAXSTONE CRAIG, 10, Hartington Gardens, Edinburgh.
 H. G. DAVEY, 40, Bronwynon Terrace, Cwmndare, Aberdare, Glam.
 G. A. FERRIS, 63, Defoe Road, Tooting, S.W.17.
 D. FOTHERINGHAM, 775, Dumbarton Road, Dalmuir, Glasgow.
 D. W. GILES, 8, Terlice Terrace, St. Dennis, St. Austell, Cornwall.
 H. R. HARVEY, 162, Warwick Road, Kensington, W.14.
 C. B. LONGLEY, "Bycullah," Ridgeway, Cuffley, Herts.
 J. MILLER, 95, High Street, Dovercourt, Essex.
 F. PROSSER, 0, Banford Avenue, Alum Rock, Birmingham, 8.
 W. G. H. ROBINSON, Forge House, Cleator, Cumberland.
 P. SHEAHAN, 83, Woodland Gardens, Isleworth, Middx.
 H. G. SMITH, 99, Kinbolton Road, Bedford.
 W. H. STREPLES, 52, Kingsway, Heanor, Derbyshire.
 A. STOTT, 198, Westmorland Avenue, Blackpool.
 R. TOWLER, 172, Main Street, Binley, Yorkshire.
 W. C. WRIGHT, 21, Clandon Road, Seven King's, Essex.

Consolation Prizes

B. ALDRED, Junr., 2, Kirkby Road, Bolton, Lancs.
 G. A. BAINSTON, 21, Beastney's Estate, Hill End, St. Albans, Herts.
 J. BARCLAY, Junr., Battlehill, Huntly, Aberdeenshire.
 F. BARKER, 10, Musgrave Tce., Walker, Newcastle-on-Tyne, 6.

HOW THE VOTING WENT		
ITEM	SCORE	ORDER OF POPULARITY
2	1,606	1
1	1,720	2
5	2,635	3
6	5,202	4
3	9,272	5
4	10,847	6



S. V. BAUCUTT, 8, Parklands Avenue, Bognor Regis.
 W. BOARDMAN, 145, Park Road, Wigan, Lancs.
 S. B. BREWER, 17, Edwin Street, Newport, Mon.
 W. BUNCE, 88, Fuller Street, Cleethorpes, Lincs.
 J. W. CONWAY, 59, Churchdale Road, Frecheville, Nr. Sheffield.
 J. W. COOPER, 49a, Church Road, Hendon, N.W.4.
 C. COPPACK, 7, Sun Street, Birkenhead.
 J. H. COURCHA, 73, Virginia Road, Shoreditch, E.2.
 W. CRITCHLEY, 6, Buxton Street, C-on-M, Manchester, 1.
 A. C. DAY, 2/12, Ravenhurst Road, Harborne, Birmingham.
 A. DEAKIN, 2, Beatrice Street, Oxenhope, Nr. Keighley, Yorks.

score—having the largest number of 1's, 2's and 3's placed against it—and so on.

(2) **CHECKING**:—The scoring gave the judges a definite order of popularity. All coupons were then checked against this.

The names and addresses of the winners of the W.B. Speakers offered as prizes appear below. Competitors with only one mistake have been awarded Consolation Prizes.

J. EDWARDS, 10, South Front., Ramsey, I.O.M.
 F. FICKLING, 14, Coreyra Street, Seaham Harbour, Co. Durham.
 R. FORRESTER, 23, Mill Street, Whitehaven.
 J. A. FORSTER, 17, Shakespeare Street, Hetton Road, Houghton-le-Spring, Co. Durham.
 W. GAMBLE, Rainey Street, Magherafelt, Co. Londonderry, N.1.
 J. S. GIBSON, 34, Oban Road, Anfield, Liverpool, 4.
 H. HART, 109, Baldwin Road, King's Norton, Birmingham.
 J. HAYMAN, 21, Elmsleigh Road, Paignton.
 J. M. MARLEY, 51, Pettits Lane, Romford, Essex.
 M. MCEWEN, "Sunnyside," 35, Park Lane, Norwich.
 W. J. MORGAN, 156, Donald Street, Cardiff, S. Wales.
 V. OULD, 55, St. Andrew Street (North), Bury St. Edmunds.
 T. PATERSON, 5, Queen's Drive, Larbert, Stirlingshire.
 G. POSTLEWAITE, 89a, Fitzalan Street, Kennington, S.E.11.
 S. R. PRATT, Compton Regis, Shrivensham, Swindon.
 H. L. RAWLINGS, 6, Chapel Hill, Station Road, Glenfield, Leicester.
 P. E. REDDING, 26, Everdon Road, Barnes, S.W.13.
 H. RILEY, 10, Fieldhouse Triangle, Nr. Halifax, Yorks.
 R. ROBINSON, 7, Newlands Avenue, Thames Ditton, Surrey.
 J. O'ROURKE, 27, Moorlands, Addlewell, Midlothian, Scotland.
 F. G. SADLER, 154, The Guinness Trust, Stamford Hill, N.16.
 R. B. SHEPHERD, 91, Kensington Road, Thorpe Bay, Essex.
 D. C. SIMMONDS, 168, Junction Road, Upper Holloway, N.19.
 W. SMITH, 252, South Frederick Street, South Shields, Durham.
 G. H. SPARK, 49, Lancaster Road, Leytonstone, E.11.
 J. STEPHEN, 29, Dorset Street, Glasgow, C.3.
 F. STEVENS, 100, St. George's Avenue, Sheerness, Kent.
 H. TAYLOR, 772, Ashton Old Road, Openshaw, Manchester, 11.
 G. WRATHERALL, 16a, Best Lane, Canterbury, Kent.
 J. O'MOORE WILLIAMS, 18, Northumberland Avenue, Kingstown, Co. Dublin, I.F.S.
 S. WOODALL, 70, Selborne Road, Dudley, Worcs.

TELEVISION TEST TRANSMISSIONS

ALTHOUGH it was stated that the Alexandra Palace television station would be off the air for at least six weeks after the close of the Olympia transmissions on September 5th, in less than four weeks test transmissions started again, "zero hour" being at 11 a.m. on October 1st. These combined vision and sound signals are to be radiated twice a day at 11 a.m. and 3 p.m., the transmissions lasting for a minimum period of one hour. It is emphasised by the B.B.C. that the signals are in no way a public service, being transmitted entirely for the benefit of the manufacturers of television receiving sets. In spite of this warning, and the fact that all sorts of adjustments may be effected at the studio end which might destroy the quality of the received picture, it is known that receiving sets are being

installed, and in many cases may be watched by members of the public. The Science Museum at South Kensington has a Cossor set installed on loan which the public can view while the transmissions are on, and at Waterloo Station two Baird sets are accommodated in a large waiting-room so that intending passengers can see the pictures prior to catching a train, provided they show their railway tickets. It is known also that many of the big London stores and radio dealers are making arrangements for erecting ultra-short-wave aerials in order to demonstrate sets. Until the service proper starts next month, however, it is

inadvisable to attempt any wide-scale demonstrations to the public. By that time the individual scanners, amplifiers, and radio transmitters should be in satisfactory working order and possible breakdowns reduced to a minimum. It was very unfortunate that on the first day a failure of the water supply at Alexandra Palace should bring about a partial breakdown of some of the Baird Co.'s equipment. The scanning units of the spotlight, intermediate film and teleciné machines have special water-cooling arrangements incorporated, while the water cooling arrangements for the ultra-short-wave vision radio transmitter are also very elaborate. Without this the heat generated cannot be satisfactorily dissipated and it is hoped that every effort will be made by the authorities concerned to prevent a recurrence of such a situation.



Write Sarcastic

ANYONE who thinks that I have over-stepped the bounds of criticism in dealing with crooners should read the record reviews appearing in a contemporary. In a recent issue they reviewed a certain record and this is what they said:—

“This is a monstrous imposition. The artiste is a clarinet player who arrived here some months ago from Australia, where he could do us no harm. He plays like a ghastly mixture of Boyd Senter, Ted Lewis and the man who always whistles when he comes to collect our empties.

“The blame for this record must lie less with the artiste himself (for he knows not what he does) than with the Parlophone Company for wasting time and money on recording him. For screamin’ out loud, are they as short of material as all that?

“I was going to conclude with a facetious remark about the title Somebody’s Wrong, but I believe my point has been made clear by this time, so we will pass on to — (here follows the next record).”

You must agree that this beats anything which I have written. It just shows the tendency of intelligent thought and the reaction of wise people to this parasitic mélange known as jazz and which ought to be purged from programmes of entertainment. I have made a vow not to attend any concert or theatre which contains any musician with the name of Lew, Ed, Al, Joe, Jack, or the rest of the appellations by which they like to be known. You could only associate jazz with such names.

Baseboards Again

THE recent discussion in these pages on the relative merits of chassis versus baseboards will be fresh in the minds of readers. I have,

On Your Length THERMION

out the doings in the same manner as they now do. However, I wish Gladstone Murray all of the best.

An Omission

WHICH reminds me that I have never broadcast, although every other great man has done so. This is a plot on the part of the B.B.C. to suppress me. I am quite sure that once my golden voice was radiated through the ether the B.B.C. would be inundated with my fan mail on the following morning, and Clapham and Dwyer, Elsie and Doris, Murgatroyd and Winterbottom, Jekyll and Hyde, would be put entirely in the shade. Do you agree, or do you? If you do you should write to the B.B.C. at once about it; they will merely turn deaf ears to my entreaties. If I don’t broadcast soon I shall have to turn to making gramophone records, and my services will be lost to the radio for ever. Loud cheers? Perhaps the B.B.C. is afraid that all the arch crooners would arrive with their trombones and saxophones or blow me one out on a trumpet!

Television Demonstrations

THE public now has ample opportunity of witnessing how excellent high-definition television is. Most of the makers will arrange for a free demonstration if you write to them. Several dealers have already installed receivers in their shops, and many others are merely awaiting delivery. The Science Museum at Kensington has installed one, and is giving demonstrations daily. Between now and Christmas the sales are expected to soar, and by that time many home constructors will have built a successful high-definition receiver. Shall we be enabled to see His Majesty the King broadcasting his Christmas message? There are free daily television programmes at Waterloo Station.

I am fortunate in possessing a set of parts for building a television receiver including the most expensive

item, the Cathode Ray Tube. Mine is a Cossor, 27ins. long; a beautiful piece of work, from which I am certain good results will be obtained. When it is working I will pass along the news.

Cheap Receivers

FOUR of my friends recently purchased cheap wireless sets costing less than £7 each. That was four months ago. Since then two of them have been back to the factory three times, one of them once, and the other has been out of action for a week. In every case a charge has been made for labour of at least £1. These cheap receivers are not so cheap when you bear in mind that they do not seem to function very long after the expiry of the guarantee. If you buy cheap you can build better for the same expenditure.

Where are the Clubs?

NOT so many years ago nearly every district boasted a wireless club, and you could always be sure of an interesting discussion on the latest receivers, components, and circuits. Very few of them remain, as you may see by reading the reports we publish in this journal. I should like to see a revival of club life, providing that it could be done on some organised basis. In the early days of wireless unscrupulous people started clubs, extracted subscriptions, and then decamped. If some well-known local individual could be persuaded to form such a club and the officers were drawn from well-known local residents whose characters are beyond reproach, the club would succeed. Most of them fail through lack of method. The members arrive at the meeting only to find that there is no proper agenda. It is all very well to have informal discussions, but members soon tire of that. A calendar of events should be carefully prepared, and lecturers with a sound knowledge invited. An annual dinner, frequent social evenings during the winter, including dances, help to keep the members together. The subscription should not be too small, for a small subscription tends to encourage every Tom, Dick and Harry, whereas a reasonable one attracts the enthusiast. Do not hold your meetings in a room at the top of some local pub, for there are those who have qualms about visiting such places. I am not among them, but I have heard of several who think the club loses caste and tone, as well as cachet, when the headquarters are above the bar. Cameraderie and good cheer are found at inns, but it is disconcerting to listen to the back-chat and bar gossip when it intersperses an interesting discussion on, say, valves.



Notes from the Test Bench

Lectures

THERE is no shortage of lecturers, for most firms will provide a man able to talk interestingly on a particular branch of radio, and the club is merely expected to pay his expenses.

Debates are always interesting and well attended, whilst field days provide a popular means of keeping the members together in the summer. Competitions can be arranged and local dealers can be persuaded to put up prizes.

It pays a club to keep in with the local dealer, and if he can set aside some part of his premises as a club-room that is all to the good. Most of them are willing to co-operate and to lend apparatus for demonstration purposes. I have no doubt that the advent of television will cause an enormous revival in the formation of clubs, and such can do yeoman service in holding public demonstrations for television.

I have no doubt also that many of the firms manufacturing television receivers would send a demonstrator to such meetings, and a technician to answer questions. There is a fruitful field here for enthusiasts and experimenters.

Without Comment!

THE following description of swing music recently appeared in a daily paper:—

“A rhythmic undulation, irrespective of tempo and mood, basically derived from Negro folk-dance music and more recently treated with increasing sophistication, generally by dance ensembles with a percussive background to a succession of improvisations by, or transcriptions for, vocal or instrumental soloists or sections on a given theme or harmonic routine. . . .”

An Enterprising London Store

MESSRS. J. COLLIER, Ltd., who own about twenty shops in Walworth Road, S.E., have opened a Radio Department and have turned their furniture showroom into a radio exhibition for one week. A performance is being given every afternoon by prominent Radio Stars, including Leonard Henry, Peggy Cochrane, Alec McGill and Gwen Vaughan, Ronald Gourley and Harry Hemsley.

A “striking” tribute was paid to G.E.C. Radio Sets which feature largely in this exhibition. Messrs. Colliers, Ltd., were unfortunate in being the victims of a smash-and-grab raid on the night before the exhibition opened, and with significant discrimination, the thief removed a G.E.C. set.

Practical Television

October 17th, 1936. Vol. 3. No. 20.

A POWER PACK FOR CATHODE-RAY TUBES

In This Article Constructional Details are Given of a Power Pack for Supplying a Cathode-ray Tube with the Necessary H.T. Current

NOW that the regular daily transmissions will officially commence next month, thousands of enthusiasts will be able to "look-in" at the first Christmas television programmes. Despite the high prices, sales of manufactured television receivers are progressing favourably, and the time has now come when the constructor can take his part in this new science.

The various receivers at present on the market, and the two types of transmission, have been fully discussed, and the technicalities explained in these columns from time to time, and it is our purpose now to introduce to constructors the various parts which go to make up the complete receiver. The cathode-ray tube and its associated power pack, the time base unit, and the vision and sound receivers proper, will all be dealt with in turn, and this week we introduce a power pack giving an output of 3,000 volts at 2 m/A—sufficient to work any but the largest of cathode-ray tubes.

Layout of Components

The power unit follows the same lines as that for an ordinary A.C. mains set and contains rectifier, transformer, and smoothing circuits, the only difference being the higher voltages. The necessary voltage dropping resistances and decoupling condensers are shown in the diagram, Fig. 1, but have not been included in the unit. These are for feeding the various anodes and shield of the cathode-ray tube, and have not been included because the values of the resistance network vary considerably for each individual type and make of tube. They can, of course, be easily added to the chassis of the unit. Those shown in the diagram are for the Cossor type 3272 tube.

Fig. 3 shows that the power pack is extremely simple and consists of two of the new Westinghouse "J" type units connected in the well-known voltage doubler circuit with reservoir condensers of 0.5 mfd. capacity. These rectifiers have a maximum current rating of 2 m/A, which is sufficient not only to feed the tube, but also to allow

for the current passed by the various potentiometers. These rectifiers have been chosen for two very good reasons—they require an input of only 1,400 volts, whereas the corresponding valve would require 3,000 volts half-wave or 3,000-0-3,000

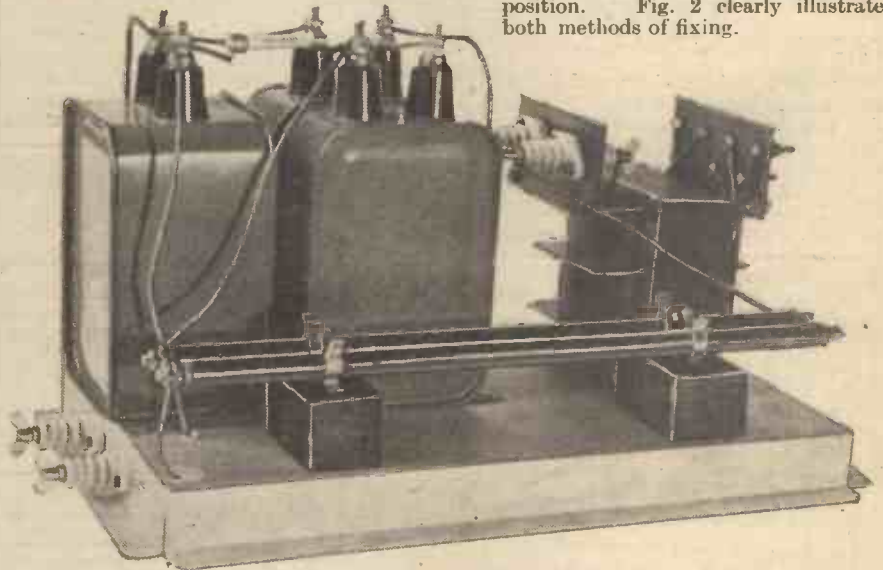

A view of the completed mains unit.

volts (6,000 volts in all) full-wave. This, of course, means that the circuit is safer, and also that the mains transformer is much cheaper and smaller as the insulation between the windings need not be so great.

Mounting the Rectifiers

The "J" type units consist of very small rectifying discs connected in series and enclosed in an insulating tube, the connections being made at each end. The rectifiers are mounted about 1in. off the metal chassis by means of two ebonite blocks. A "Terry" spring clip is fixed to each block by means of a bolt screwed into a hole

tapped in the centre of the block. Care must be taken to see that this bolt does not go right through the block and touch the chassis, as this would stress the insulation of the rectifiers unduly, especially at the high potential end. The manufacturers of the rectifiers state that the material used for the insulating tubes will withstand a stress of 3,000 volts so that the use of an ebonite block, with the tubes entirely insulated from the chassis, is an extra factor of safety. The blocks are fixed to the chassis by the two nuts and bolts shown in Fig. 2.

Another method of fixing is to drill a 7-16th hole through the centre of each block, and then to cut each block in half. The rectifier is then laid in the semi-circle formed in the bottom half of the ebonite, and the other half of the block placed on top. The whole is then bolted to the chassis, thus holding the rectifier firmly in position. Fig. 2 clearly illustrates both methods of fixing.

Wiring Connections

Having fixed the rectifiers, transformer, and condensers in position, the wiring becomes a matter of a few minutes' work. Use 18 or 20 gauge tinned copper wire, covered with a good thick insulating sleeving. Where wires pass through the chassis, make sure that there is ample clearance between the sleeving and the chassis, and cover the sleeving with a short length of larger diameter sleeving at the point where it passes through the chassis. Note that, because the cathode of the television tube is at high potential, a separate H.T. negative line has

(Continued overleaf)

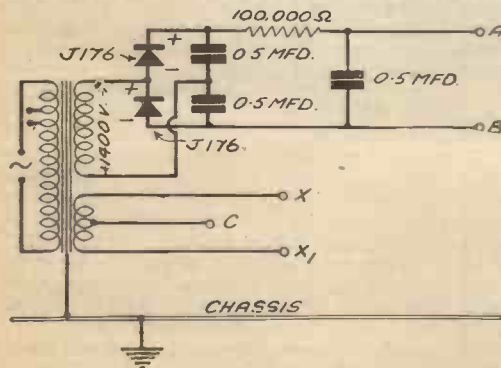
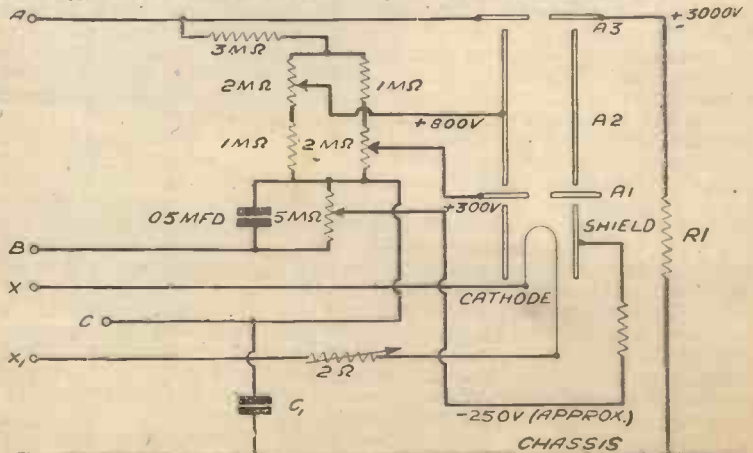

Fig. 1.—Theoretical circuit of the mains unit, and, on the right, the full C.-R. tube circuit.



(Continued from previous page)

to be employed, and it is not possible to connect this to the metal chassis. A separate earthing terminal is provided for earthing the chassis which is entirely insulated from both H.T. positive and negative.

Instead of the more usual smoothing choke, a resistance has been used for smoothing purposes, as a choke is not a practical proposition in circuits such as this, and a resistance is certainly very much cheaper.

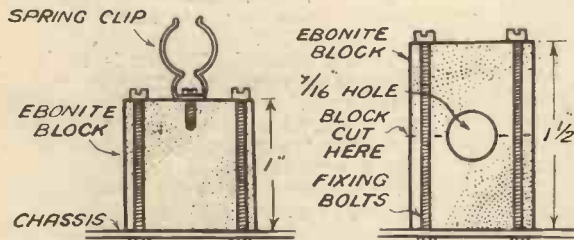

Fig. 2—Constructional details of the supports for the metal rectifiers.

The value is 100,000 ohms, and that of the smoothing condenser 0.5 mfd. Note that this condenser is of the 4,000 volts D.C. working type, while the reservoir condensers are rated at 2,500 volts D.C. working. The volts dropped in the resistance are 200 when the full current of 2 m/A is taken so that, in such a case, the maximum

voltage available would be 2,800—sufficient to work the tube efficiently.

In Fig. 1 is shown the voltage network for a Cossor tube. It can easily be calculated from the values given for the various resistances making up the potentiometers that the current passed by these is 0.46 m/A. The current taken by the tube is about another 0.5 m/A, so that the total current required is under 1 m/A, at which figure the voltage output from the pack will be about 3,500 volts.

Resistance Network

The resistance network is arranged to provide the full available voltage to the third anode, about 800 volts to the second, and 300 volts to the first, while the 500,000 ohms potentiometer at the bottom of the network is used to deliver a negative voltage to the shield, varying between 180 and 450 volts, approximately. The third anode

of the tube should be at or near earth potential. It is preferable, however, not to connect it direct to earth as this would

involve a certain ripple on the cathode voltage relative to earth. Although this percentage ripple would be very small, the total voltage is very high, and hence an appreciable 50-cycle hum would be introduced which would appear on the screen, and spoil the picture. To avoid this, the third anode is connected to earth through the high resistance R.1, whilst the cathode of the tube is earthed in the A.C. sense through the high-voltage condenser C.1. Note that the deflector plates and their associated circuits are not shown in the diagram.

In conclusion, we would stress that, although the unit has been made as simple as possible, great care must be taken with insulation. The variable potentiometers for voltage control must have their spindles well insulated from the chassis. In fact, it is preferable to use an ebonite panel, and the hole in the knobs through which the grub fixing screws pass should be filled with wax when the knobs have been securely fixed to the spindles. On no account make any alterations to the wiring, or touch any of the components, or chassis, while the unit is switched on.

- COMPONENTS REQUIRED**
- Two Westinghouse type "J.176" metal rectifiers.
 - One mains transformer, primary tapped 200, 220, 240 volts, secondary 1,400 volts and 2 volts 2 amps.—London Transformer Products.
 - Two oil-immersed paper dielectric condensers, capacity 0.5 mfd., 2,500 volts D.C. working type—Dubilier.
 - One oil-immersed paper dielectric condenser, capacity 0.5 mfd., 4000 volts D.C. working type—Dubilier.
 - One 100,000 ohms 1 watt metallised resistance—Dubilier.
 - Two porcelain insulated terminals—Belling Lee.
 - One aluminium chassis 13in. by 10in. by 2in. Nuts and bolts, wire and sleeving.

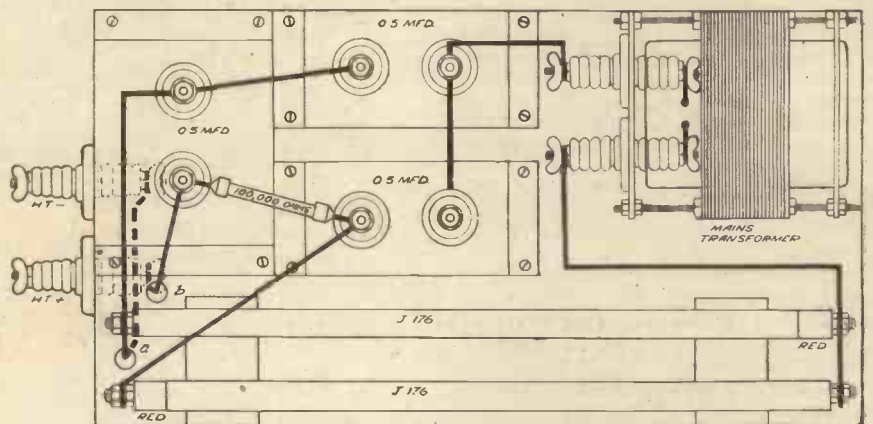

Fig. 3—Wiring diagram of the television mains unit.

Frames, Pictures, and Flicker

A MISUNDERSTANDING exists concerning the terms "frames" and "pictures" in so far as television pictures are concerned.

This has arisen as a result of the two standards of transmission now employed at the Alexandra Palace television station. In one case a definition of 240 lines with a frame frequency of 25 and a picture frequency of 25 is employed, the scanning being sequential or consecutive.

The second employs a definition of 405 lines with a frame frequency of 50 and a picture frequency of 25, the scanning being interlaced or intercalated. Many people are under the impression that the latter system uses 50 pictures per second, but this is not so. Due to the interlaced method of scanning half a picture is explored in each frame, the odd lines of one frame and the even lines of the succeeding frame being dovetailed together to give a complete picture. Each frame has a definition of 202½ lines, but the total picture repeated at 25 times per second has the full definition of 405 lines.

This latter scheme was put forward and developed as one method for reducing the effects of flicker. The eye does not respond instantly to any form of light stimulus, and conversely the light sensation of the eye does not cease immediately the stimulus is removed. It follows, therefore, that if

TELEVISION NOTES

the eye watches a source of illumination which is flickering, the changes will become imperceptible after a certain critical frequency, a frequency which, however, varies directly with the overall measure of illumination. It is for this last-named reason that modern cathode-ray tubes with their bright screens have brought the subject of flicker so much into prominence. Increasing the frame frequency does not necessarily bring about the best solution to the flicker question, and in many quarters it is felt that the cathode-ray tube itself having emphasised flicker will also furnish a means of overcoming it. With a cathode-ray tube screen the spot illumination does not die down suddenly, but exponentially. If, therefore, a screen material could be made which possessing other television requisites would persist in illumination for the duration of a complete picture period, then a flickerless picture would be available without in any way increasing the sideband required for the radiated video signal. It is to be hoped that the chemists engaged on this work will be successful in their efforts, as the available sideband can then be devoted to any improvements in definition that may be required to keep pace with future developments.

Television in the Air

While the low-definition television service was in full swing some interesting reception tests were undertaken on an L.N.E.R. express train. A recent high-definition television reception test, however, was much more spectacular in character. It was carried out during the Radiolympia transmissions, and for the work a K. L. M. Douglas aeroplane was employed. A standard Baird receiving set was installed in the machine, deriving its A. C. power from a small motor alternator. With a party of sixteen Press men on board, the machine cruised over London and pictures were clearly visible on the television screen during the whole of the trip. This is the first time a feat of this nature has been undertaken. The distance over which the signals radiated from the Alexandra Palace will reach in the air without troubles from hill or building screening will undoubtedly be very great, and it is conceivable that television receiving sets could be installed in large aeroplanes for the entertainment of passengers. It seems certain also that transmissions from the air will be undertaken with a scanner operating through a windowed floor. Again, it is not too much to expect that the pilot will ultimately have cockpit sets installed so that he can "see" his flying direction, although his visibility is obscured by fog.

ADD-ON SUPERHET UNIT

(Concluded from last week's issue)

It should be noted that the rise and fall of the glow in the neon tube is actuated by the A.V.C. action of the Westector in feeding back an increasing negative bias as the station is tuned in. Since this bias is dependent on the signal strength impressed on the Westector, it will vary as and when "fading" occurs. For this reason, it is a good plan to trim as accurately as possible at night, and then make the final adjustments in broad daylight, when fading is less likely to occur. No additional trimming is required for the long waveband.

Provision for gramophone reproduction is made by connecting the pick-up to earth and terminal "P" of the switch situated at the front of the coil unit.

List of Stations Received in Broad Daylight in North London.

Long Waves.		Remarks.
Heston	Air Ministry station—weather reports only.
Kalundborg	Fair strength.
Luxembourg	Very strong.
Motala	Fair—side-band chatter.
Droitwich	Very strong—excellent quality.
Deutschlandsender	..	Strong—side-band chatter from Paris.
Radio-Paris	Strong.
Hilversum	Strong.

Medium Waves.		Remarks.
Brussels No. 1	Good; straight, free of interference.
North Regional	
Paris PTT	
Scottish Regional	
West Regional	
London Regional	This station was not identified. Good programme value. Probably Nice or Frankfurt.
Midland Regional	
Radio-Normandie	
London National	
250 metres approx.	..	

Several other medium-wave stations were received, but either signal strength was not sufficient or reception was spoiled by severe atmospherics. Atmospheric conditions—fair. Long-distance stations suffered slightly.

List of Stations Received Between 9 and 11 p.m.

Long Waves.		Remarks.
Heston	All good programme value free of interference, except Deutschlandsender, which suffers from slight side-band chatter.
Kalundborg	
Luxembourg	
Warsaw	
Motala	
Droitwich	
Deutschlandsender	..	This station has been received at great strength from time to time when the set has been tested out.
Radio-Paris	
Hilversum	
Moscow	

Medium Waves.		Remarks.
Radio-Lyons	Fair strength.
225 metres approx.	..	Unidentified French station.
230 metres approx.	..	Unidentified station broadcasting English dance music, English announcer.
235 metres approx.	..	Unidentified station.
240 metres approx.	..	Unidentified station. German.
245 metres approx.	..	Unidentified station.
247 metres	Strong. Probably Lille.
Frankfurt	Good programme value.
253 metres approx.	..	Unidentified. Probably Nice.
258 metres approx.	..	Unidentified.
London National	Very good quality.
Trieste	Fair strength.
Radio-Normandie	Very strong. Quality not very good.
270 metres approx.	..	Unidentified.
Bordeaux	Fair.
Scottish National	Not very strong.
Genes	Quite good power and quality.
Midland Regional	Good strength and quality.
200 metres approx.	..	Unidentified station. Probably Hilversum.
205 metres approx.	..	Unidentified station. Italian.

Belfast	Fair strength. Has faded at times under test, but not very badly.
Poste Parisien	Very strong.
Breslau	Good quality. Strong.
325 metres approx.	..	Unidentified station. Side-band chatter.
Toulouse	Strong. Fair quality.
Hamburg	Strong.
London Regional	Excellent quality.
Strasbourg	Quite strong and clear of London Regional.
Berlin	Very good.
Bucharest	Fair strength.
Milan	Good strength and quality.
West Regional	Often used with North Regional to form a stand-by to the Regional programme. Good reception.
375 metres approx.	..	Unidentified station. Not much programme value. Side-band chatter.
Leipzig	A good station.
Toulouse PTT	Good station.
Scottish Regional	Quite a good station.
Katowice	Fair.
Marseilles	Good.
Munich	An excellent station for power and quality.

Rome	An excellent station for power and quality.
Stockholm	Spoilt by side-band chatter.
Paris PTT	A good station.
Sottens	Fairly good station.
North Regional	See remarks under West Regional.
Cologne	A good programme, but spoilt by heterodyne whistles.
Lyons PTT	Fair programme value.
Prague	An excellent stand-by station. Good power and quality.
Brussels No 1	A good station. Always receivable in daylight.
Florence	Fair.
Vienna	Can usually be relied upon. Good power and quality.
514 metres approx.	..	Not much programme value.
Stuttgart	Very powerful.
Athlone	Good.
Beromünster	Fairly good station.
Budapest	Atmospherics. Otherwise fair station.

All the above stations have a definite programme value in London. Others have been obtained from time to time when testing. Reception will naturally vary according to atmospheric conditions. A good aerial and earth system was used when carrying out the above tests.

Why do they sound so MUCH better?

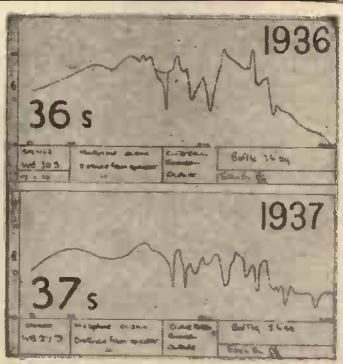

Cabinet Models			
37SC (Senior)	63/-
37JC (Junior)	49/6
37CC (Cadet)	39/6
37BC (Baby)	29/6

Chassis Models			
37S.	42/-
37J.	32/6
37B.	23/6
37M.	17/6

The larger models are available on Hire Purchase through your dealer. Terms from 7/6 down.

Mr. Camm says:
"A marked advance on previous models!"



To the eye there is little apparent difference between one year's speaker and another. It is natural, therefore, that when his ear notices the newest Stentorian's marked improvement in performance, the listener should ask "How? Why?"

Complete answers would occupy several books; for eight enthusiastic designers cannot report on a whole year's work in a few words. Here, however, are two important points:—

Further improvement in magnetic material

An alteration in the magnetic alloy has brought about 15% increased flux. Hence the greater volume and range. (Note: The material is exclusive to 1937 Stentorians.)

New Seamless Cone

W.B. Engineers have evolved the first seamless cone to offer advantages over the special "seamed" type used before. This new cone is manufactured in the W.B. factory from an exclusive and carefully prepared pulp. It reduces resonances enormously.

These two points provide a partial answer only—for every part of the new design has been studied, experimented with, and improved. The extra results as seen in the above curves taken from 1936 and 1937 Stentorian Senior Speakers are definite and substantial.

This new reproduction is available to you. Ask your dealer.

1937 STENTORIAN

Permanent Magnet Moving-Coil Speakers

Facts and Figures

COMPONENTS TESTED IN OUR NEW LABORATORY

The G.L. Unit

A USEFUL accessory for the construction of a small battery receiver of the "pocket" type is illustrated below. This consists of the essentials of two L.F. amplifying stages, and includes an additional valveholder for the initial stage. The theoretical circuit is shown and it will be

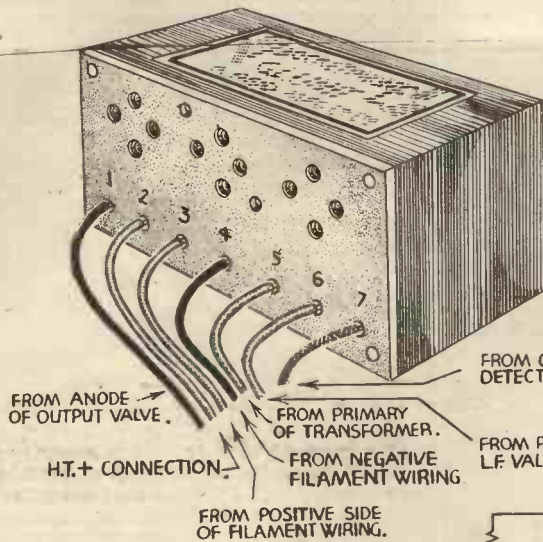

FROM ANODE OF OUTPUT VALVE.
H.T.+ CONNECTION.
FROM POSITIVE SIDE OF FILAMENT WIRING.
FROM PRIMARY OF TRANSFORMER.
FROM NEGATIVE FILAMENT WIRING.
FROM GRID OF DETECTOR VALVE.
FROM PLATE OF L.F. VALVE.

The novel G.L. unit is seen above, and on the right is the theoretical circuit which is used in the device.

seen that one only needs a tuning circuit, grid leak and condenser in order to build a simple three-valve receiver. Leads are brought out for connection to the batteries and tuning circuit, and it is possible to use this unit with an outside aerial or a self-contained aerial wound in the form of a frame. In this case, of course, no tuning coil would be required, and the construction would be even simpler. The price of the complete unit is 18s. 9d., and special variable condensers are available for tuning and reaction purposes at 2s. each. The makers are A. Reid Manufacturing Co., Ltd., 14A, Clerkenwell Green, E.C.1.

Messrs. Lissen

WE are asked to point out that the Isleworth factory of the Lissen Company is now closed, and the head office and works are now situated at Angel Road, Edmonton, N.18. The London Sales Office is at 113-117, Charing Cross Road, W.C.2.

An Exide Innovation

AN interesting announcement has just been made by the Chloride Storage and Battery Company regarding the Exide I.T. cells. In future special labels will be issued for various well-known commercial receivers and will be attached to the cells in order to identify them. Twelve types of cell are being introduced to inaugurate the scheme, and others will be added from time to time.

New Belling Lee Terminal Mount

IN the modern power amplifier, and especially in television equipment, certain terminal points are arranged at very high differences of potential, and extreme care is necessary to avoid flash-over or other leakage. By using separated terminal mounts or otherwise arranging the terminals this can easily be done, but to simplify matters Messrs. Belling Lee have just introduced a new pattern of their popular terminal mount suitable for use on voltages up to 7,000, and this is shown below. As will be seen, an additional leakage path is provided between the two terminals by cutting a recess round each hole, on the underside, and the pillars upon which the terminals are mounted are longer and of greater diameter than in the standard pattern. The general dimensions are, however, practically the same as in the older type of mount.

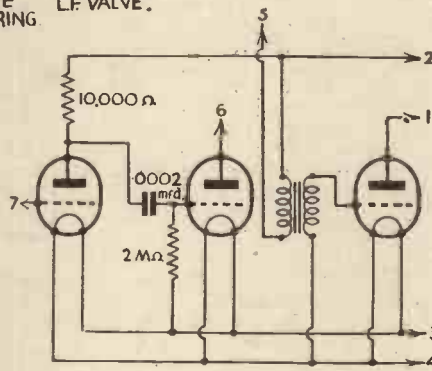

Connection to the terminals may be made direct, or through the medium of the short metal lugs which may be attached beneath the locking nuts and which then project as shown in the left-hand illustration. The price of this new mount is 6d.

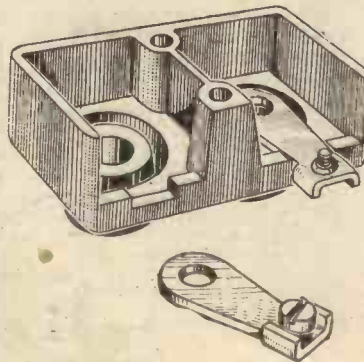

Frequency Test Records

A NEW set of frequency test records is announced by His Master's Voice. Separate records are available to cover the range from 8,500 down to 25 cycles per second, with the addition of a single side to cover exactly the same range but in the form of a sliding scale. The single records are divided up into four discs, numbered DB4034 to DB4037 inclusive. The first disc covers from 8,500 to 2,250 c.p.s., the second, 2,000 to 500 c.p.s., and the third, 450 to 100 c.p.s. The fourth record has on one side the remainder of the range from 90 to 25 c.p.s., with the sliding scale on the reverse side. The discs cost 6s. each, but a special album is available at 4s., with which is given free a stroboscopic speed indicator, the new automatic groove indicator, and full instructions for using the latter instrument. It enables any desired frequency instantly to be picked out, as well as having practical uses in other directions. If desired, this indicator may be obtained separately at 2s. 6d. in a case.

Acorn Valveholder

THE introduction of the Acorn type of valve has led to the necessity for a special valveholder. The first to be introduced is the Quadrant, made by the Quadrant Carbon & Metal Products Company, of Cumberland Road, Stanmore, Middlesex, and this is of bakelite construction with phosphor-bronze contacts (silver plated), and with top and under chassis soldering lugs for connecting purposes. Prices have not yet been announced.

E. J. Heraud, Ltd.

THE well-known mail order house of Heraud's, Edmonton, are now able to supply all modern components on hire-purchase terms. The latest additions to the range which they stock are the Vidor short-wave converter and the new 1937 W.B. loud-speakers. These items are available for 5s. deposit, and repayments are made at very low figures. In the case of the converter, this is supplied on seven days' trial for 5s., and if retained a further 2s. 6d. is payable, after which nine monthly payments of 5s. will complete purchase. The new Stentorian Junior is sent on approval for only 5s., and payment is completed by six monthly instalments of 5s. Details of other apparatus obtainable from this firm may be obtained on application to them. The full postal address is E. J. Heraud, Ltd., Edmonton, London N.18.

LATHE WORK for AMATEURS

1/-, by post 1/2, from
GEORGE NEWNES, LTD.,
8-11, Southampton Street, Strand, London, W.C.2

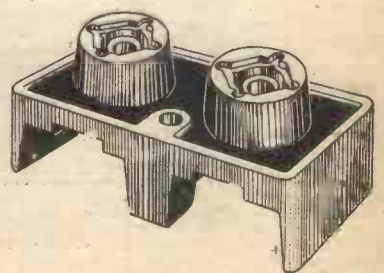

A new terminal mount by Belling Lee, designed for use on high voltage apparatus.



IMPRESSIONS ON THE WAX

By
T. O'nearm

Famous Singers

GIGLI, who has just finished his second film, now being shown in Germany under the title of "Ave Maria," sings two songs in the new H.M.V. releases for this month, which are introduced into it. They are "Soltanto tu, Maria" and "Anima mia" on *H.M.V. DA 1487*.

Kirsten Flagstad, who made her debut at Covent Garden this year, also makes a new record this month. She sings two of Grieg's songs, "Ich Liebe Dich" (I Love Thee) and "Ein Traum" (A Dream), on *H.M.V. DA 1505*.

John McCormack, never better than when singing the ditties of his native Ireland, has chosen this month "The Kerry Dance" and "Green Isle of Erin"—*H.M.V. DB 2848*.

Paul Robeson's New Film

PAUL ROBESON has recorded four of the songs from his new film "Song of Freedom" in the new H.M.V. lists. They are, "Sleepy River" (with Elisabeth Welch) and "Song of Freedom"—*H.M.V. B 8482*, and "Lonely Road" and "Black Emperor"—*H.M.V. B 8483*.

Another great singer who makes a welcome appearance this month is Peter Dawson, who is in first-class form in "Mother o' Mine" coupled with the rather grim "Danny Deever" on *H.M.V. B 8487*.

Light Vocals

TWO interesting new releases are Frances Day singing two songs, "Love's Melody" and "So Must Our Love Remain" from her new film "Dreams Come True," on *H.M.V. BD 366*, and Molly Picoon, the clever American comedienne, who is very funny in "It's Love" coupled with "Nervous" on *H.M.V. B 8486*.

One of the greatest successes of the autumn theatre season is Lew Leslie's "Blackbirds of 1936" now running at the Lyceum Theatre, London. H.M.V. have just issued two songs by Lavaida Carter, one of the stars of the show—"Dixie isn't Dixie any More" and "Jo-Jo, the Cannibal Kid"—on *H.M.V. BD 365*.

Two other artists in this company are the Nicholas Brothers, who sing "Your heart and Mine" and "Keep a Twinkle in Your Eye" on *H.M.V. BD 373*. In the latter tune one of the brothers does some clever tap dancing. The making of this record faced the H.M.V. engineers with considerable problems, which they overcame by using three microphones, one of them being placed at the feet of the dancer.

Ballet Music—"Aurora's Wedding"

FOLLOWING on the delightful records of "La Boutique Fantasque," H.M.V. have now issued four records of Tchaikovsky's "Aurora's Wedding," one of the most charming items in the repertoire of Colonel W. de Basil's Ballets Russes. You will recognise old favourites in this, a little of the "Sleeping Beauty," some of the "Casse-Noisette," and so forth. If you have only judged Tchaikovsky by his symphonies, make a point of listening

to this carefree music, played by the London Philharmonic Orchestra, conducted by Efreim Kurty on *H.M.V. C 2853-5*.

Silly Symphony

IT was a bold experiment to divorce the music from the pictures, but owing to Walt Disney's flair for choosing just the right music, these H.M.V. records of the sound of his films are excellent entertainment, whether you happen to have seen the pictures or not. "Lullaby Land" is now issued and in addition to the "original" music, such items as Brahms's "Cradle Song" are introduced. The number of the record is *H.M.V. BD 370*.

Dancing Time

JACK HYLTON figures in the dance section of the October list with tunes from the new Palladium show "O-Kay for Sound." They are "Free" and "The Fleet's in Port Again" on *H.M.V. BD 5102*.

One of the most popular tunes of recent months is "Shoe-shine Boy" and Roy Fox has now recorded it on *H.M.V. BD 5107*; on the other side is another popular tune, "It's a Sin to Tell a Lie." Joe Loss and his Orchestra also feature on the "His Master's Voice" list this month, playing "Everybody Dance," from the film of the same name, on *H.M.V. BD 5109*. This tune is coupled with "Cryin' My Heart Out for You." This band also plays "Until To-morrow" and "There's a New World" on *H.M.V. BD 5110*.

Anyone who likes to hear rhythmic piano playing will appreciate "Fats" Waller's latest effort, "Until the Real Thing Comes Along" and "You're Not the Kind" on *H.M.V. BD 5115*.

Two Great Swing Bands

RECORDS of two great swing orchestras are issued this month by "His Master's Voice." The first record is of the Quintette of the Hot Club of France, which is reputed to be the best swing orchestra in the whole of France. They have recorded new arrangements of "After You've Gone" and "Oriental Shuffle" on *H.M.V. B 8479*. The other two swing records this month are played by Benny Goodman and his Orchestra. The titles of the records are "Stompin at the Savoy" and "If I could be with you" on *H.M.V. B 8480*, and "Swingtime in the Rockies" coupled with "I've Found a New Baby" on *H.M.V. B 8481*.

NEWNES (Illustrated) TELEVISION and SHORT-WAVE HANDBOOK

by F. J. CAMM
(Editor "Practical Television," "Practical and Amateur Wires," etc.)

EVERYTHING ABOUT—
Drums, Mirror Screws, Scanning Discs and other Scanning Systems, Neon Lamps, the Cathode-Ray Oscillograph. How to build Short-Wave Receivers; How to build Ultra-Short Wave Receivers, straight and superhet types.

280 pages Only 3/6 net

or 4/- post free from—
GEORGE NEWNES, LIMITED
8-11, Southampton St., Strand, W.C.2

EASY TERMS

NEW 1936-1937 RADIO

FOR MORE THAN TEN YEARS we have SPECIALISED in the supply of all good quality RADIO SETS, COMPONENTS, VALVES and ACCESSORIES. SEND LIST OF YOUR REQUIREMENTS and we will supply keen quotation by return.



W.B. STENTORIAN SPEAKERS

These splendid Speakers are available on Easy Terms—
37J Cash price 32/6, or 2/6 with order and 11 monthly payments of 2/-.
CABINET and EXTENSION SPEAKERS on similar terms.
FULL LIST ON REQUEST.

Wharfedale, Goodman's & Rola Loudspeaker Units

Supplied on the best terms—Complete list sent free.

★ McCARTHY CHASSIS ★

The remarkable New Model RF6AW ALL-WAVE CHASSIS—Cash price 28/10/-, or delivered for First Payment, 21/7/-, and 10 monthly payments of 16/-. Complete Price List available on request.

LATEST PICK-UPS, GRAMO-MOTORS & VALVES

All the newest products of well-known Makers supplied on the best of Easy Terms. WRITE FOR NEW VALVE LIST.

'Avomitor' Testing Meter

A most valuable instrument for tracing faults, etc. £2 cash, or 2/- with order, and 10 monthly payments of 2/.

ELIMINATORS

All well-known makes supplied for FIRST PAYMENT of 5/-.

WE GUARANTEE SATISFACTION TO EVERY CUSTOMER. PROMPT DELIVERY. CASH or C.O.D. ORDERS SENT BY RETURN.

Estd. 1925 THE NATIONAL 1977

LONDON RADIO SUPPLY COMPANY

11, OAT LANE, NOBLE STREET, LONDON, E.C.2

For SHORT WAVE Enthusiasts Get your copy early!



EDDYSTONE 1937 SHORT WAVE MANUAL

FOYLES

Booksellers to the World.

Special department for Wireless Books.
119-125 CHARING CROSS RD., LONDON, W.C.2
Telephone: Gerrard 5660 (12 lines).

PATENTS AND TRADEMARKS.

KINGS PATENT AGENCY (Director: B. T. King, Patent Agent). Advice, Handbook and Consultations free.—146A, Queen Victoria Street, E.C.4. Phone: City 0101.



A Selection for the Modern Handyman

THE HANDYMAN'S ENQUIRE WITHIN. Hundreds of practical ideas and hints—many not hitherto published. Classified according to the subjects dealt with, an index being provided to facilitate speedy reference.

MODEL AIRSHIPS AND AEROPLANES. This handbook is intended as a guide to the beginner in model aeronautics. It presents in clear language the first principles of aviation and incorporates these in various forms of simple flying models. Profusely illustrated.

ACCUMULATORS. An accumulator (whether for wireless or the car), if properly used and cared for, is an extremely reliable piece of apparatus. Proper care and proper use can only follow a possession of the knowledge which study of this book will impart.

SIMPLE ELECTRICAL APPARATUS. Interesting and useful apparatus, easily constructed, with which the student is enabled to test for himself the theory and practice of electricity as laid down in the textbooks. 138 illustrations.

THE HOME WOODWORKER. The various examples of woodwork described in this handbook have been designed by practical craftsmen. They are modern in style, and their construction is well within the powers of the average homemaker who follows the instructions given.

MOTOR CAR OVERHAUL AND UPKEEP. There are many to-day who by undertaking their own repairs can afford to run a car, and it is the purpose of this profusely illustrated handbook to explain how the owner-driver may carry out most of the adjustments and repairs which every car sooner or later needs.

POWER-DRIVEN MODEL AIRCRAFT. All about petrol, compressed-air and steam engines, wheels, carburetors, ignition systems, rotary engines, etc., with special constructor's chapters, ranging from compressed-air models for beginners to advanced petrol-engined planes. With 130 sketches, diagrams, and photographs.

1! NEWNES HOME MECHANIC BOOKS

or 1/2 each post free from George Newnes, Limited, 8-11, Southampton Street, Strand, London, W.C.2

Practical and Amateur Wireless BLUEPRINT SERVICE

PRACTICAL WIRELESS STRAIGHT SETS. Battery Operated.		
One-valve : Blueprint, 1s. each.		
	Date of Issue	No. of Blueprint
All-wave Unipen (Pentode)	..	PW31A
Two-valve : Blueprints, 1s. each.		
Four-range Super Mag Two (D, Pen)	11.8.34	PW36B
Three-valve : Blueprints, 1s. each.		
Selectone Battery Three (D, 2 LF (Trans.))	..	PW10
Sixty-Shilling Three (D, 2 LF (RC & Trans.))	2.12.33	PW34A
Leader Three (SG, D, Pow)	..	PW35
Summit Three (HF Pen, D, Pen)	8.8.34	PW37
All Pentode Three (HF Pen, D (Pen), Pen)	22.9.34	PW39
Hall-Mark Three (SG, D, Pow)	..	PW41
Hall-Mark Cadet (D, LF Pen (RC))	10.3.35	PW48
F. J. Camm's Silver Souvenir (HF Pen, D (Pen), Pen) (All-Wave Three)	13.4.35	PW49
Genet Midget (D, 2 LF (Trans.))	June '35	PM2
Cameo Midget Three (D, 2 LF (Trans.))	8.6.35	PW51
1936 Sonotone Three-Four (HF Pen, HF Pen, Westector, Pen)	17.8.35	PW53
Battery All-Wave Three (D, 2 LF (RC))	31.8.35	PW55
The Monitor (HF Pen, D, Pen)	..	PW61
The Tutor Three (HF Pen, D, Pen)	21.3.36	PW62
The Centaur Three (SG, D, P)	..	PW64
The Gladiator All-Wave Three	29.8.36	PW66
Four-valve : Blueprints, 1s. each.		
Fury Four (2 SG, D, Pen)	..	PW11
Beta Universal Four (SG, D, LF, Cl. B)	15.4.33	PW17
Nucleon Class B Four (SG, D (SG), LF, Cl. B)	6.1.34	PW34B
Fury Four Super (SG, SG, D, Pen)	..	PW34C
Battery Hall-Mark 4 (HF Pen, D, Push-Pull)	..	PW46
F. J. Camm's "Limit" All-Wave Four (HF Pen, D, LF, P.)	26.9.36	PW67
Mains Operated.		
Two-valve : Blueprints, 1s. each.		
A.C. Twin (D (Pen), Pen)	..	PW18
A.C. D.C. Two (SG, Power)	7.10.33	PW31
Selection A.C. Radiogram Two (D, Pow)	..	PW19
Three-valve : Blueprints 1s. each.		
Double-Diode-Triode Three (HF Pen, DDT, Pen)	10.6.33	PW23
D.C. Ace (SG, D, Pen)	15.7.33	PW25
A.C. Three (SG, D, Pen)	..	PW29
A.C. Leader (HF Pen, D, Pow)	7.4.34	PW35C
D.C. Premier (HF Pen, D, Pen)	31.3.34	PW35B
Ubique (HF Pen, D (Pen), Pen)	28.7.34	PW36A
Armada Mains Three (HF Pen, D, Pen)	18.8.34	PW38
F. J. Camm's A.C. All-Wave Silver Souvenir Three (HF Pen, D, Pen)	11.5.35	PW50
"All-Wave" A.C. Three (D, 2 LF (RC))	17.8.35	PW54
A.C. 1936 Sonotone (HF Pen, HF Pen, Westector, Pen)	31.8.35	PW56
Four-valve : Blueprints, 1s. each.		
A.C. Fury Four (SG, SG, D, Pen)	..	PW20
A.C. Fury Four Super (SG, SG, D, Pen)	..	PW34D
A.C. Hall-Mark (HF Pen, D, Push-Pull)	..	PW45
Universal Hall-Mark (HF Pen, D, Push-Pull)	0.2.35	PW47
SUPERHETS.		
Battery Sets : Blueprints, 1s. each.		
£5 Superhet (Three-valve)	..	PW40
F. J. Camm's 2-valve Superhet (Two-valve)	13.7.35	PW52
F. J. Camm's £4 Superhet	..	PW58
Mains Sets : Blueprints, 1s. each.		
A.C. £5 Superhet (Three-valve)	..	PW43
D.C. £5 Superhet (Three-valve)	1.12.34	PW42
Universal £5 Superhet (Three-valve)	..	PW44
F. J. Camm's A.C. £4 Superhet 4	..	PW59
F. J. Camm's Universal £4 Superhet 4	11.1.36	PW60
SHORT-WAVE SETS.		
Two-valve : Blueprints, 1s. each.		
Midget Short-Wave Two (D, Pen)	15.9.34	PW38A
Three-valve : Blueprints, 1s. each.		
Experimenter's Short-Wave Three (SG, D, Pow)	..	PW30A
The Perfect 3 (D, 2 LF, RC and Trans)	..	PW63

PORTABLES.		
Three-valve : Blueprints, 1s. each.		
F. J. Camm's ELF Three-valve Portable (HF Pen, D, Pen)	16.5.36	PW65
Four-valve : Blueprints, 1s. each.		
Featherweight Portable Four (SG, D, LF, Cl. B)	..	PW12
MISCELLANEOUS.		
S.W. Converter-Adapter (1 valve)	..	PW48A
AMATEUR WIRELESS AND WIRELESS MAGAZINE		
CRYSTAL SETS.		
Blueprints, 6d. each.		
Four-station Crystal Set	..	AW427
1934 Crystal Set	..	AW444
150-mile Crystal Set	..	AW450
STRAIGHT SETS. Battery Operated.		
One-valve : Blueprints, 1s. each.		
B.B.C. Special One-valver	..	AW387
Twenty-station Loud-speaker One-valver (Class B)	..	AW449
Two-valve : Blueprints, 1s. each.		
Melody Ranger Two (D, Trans)	..	AW388
Full-volume Two (SG, Det, Pen)	..	AW302
B.B.C. National Two with Lucerne Coil (D, Trans)	..	AW377A
Big-power Melody Two with Lucerne Coil (SG, Trans)	..	AW338A
Lucerne Minor (D, Pen)	..	AW426
A Modern Two-valver	July '36	WM400
Three-valve : Blueprints, 1s. each.		
Class-B Three (D, Trans, Class B)	22.4.33	AW386
New Britain's Favourite Three (D, Trans, Class B)	15.7.33	AW394
Home-Built Coil Three (SG, D, Trans)	..	AW404
Fan and Family Three (D, Trans, Class B)	25.11.33	AW410
£5 5s. S.G.3 (SG, D, Trans)	2.12.33	AW412
1934 Ether Searcher: Baseboard Model (SG, D, Pen)	20.1.34	AW417
1934 Ether Searcher: Chassis Model (SG, D, Pen)	..	AW410
Lucerne Ranger (SG, D, Trans)	..	AW422
Cosior Melody Maker with Lucerne Coils	..	AW423
P.W.H. Mascot with Lucerne Coils (D, RC, Trans)	..	AW374A
Mullard Master Three with Lucerne Coils	..	AW424
£5 5s. Three: De Luxe Version (SG, D, Trans)	19.5.34	AW435
Lucerne Straight Three (D, RC, Trans)	..	AW437
All Britain Three (HF Pen, D, Pen)	..	AW448
"Wireless League" Three (HF Pen, D, Pen)	3.11.34	AW451
Transportable Three (SG, D, Pen)	..	WM271
£3 6s. Radiogram (D, RC, Trans)	..	WM318
Simple-tune Three (SG, D, Pen)	June '33	WM327
Economy-pentode Three (SG, D, Pen)	Oct. '33	WM387
"W.M." 1934 Standard Three (SG, D, Pen)	..	WM351
£3 3s. Three (SG, D, Trans)	Mar. '34	WM354
Iron-core Band-pass Three (SG, D, QP21)	June '34	WM362
1935 £6 6s. Battery Three (SG, D, Pen)	..	WM371
PTP Three (Pen, D, Pen)	June '35	WM389
Certainty Three (SG, D, Pen)	Sept. '35	WM393
Minitube Three (SG, D, Trans)	Oct. '35	WM396
All-wave Winning Three (SG, D, Pen)	Dec. '35	WM420
Five-valve : Blueprints, 1s. 6d. each.		
Super-quality Five (2 HF, D, RC, Trans)	May '33	WM321
New Class-B Five (2 SG, D, LF, Class B)	Nov. '33	WM340
Class-B Quadradyne (2 SG, D, LF, Class B)	Dec. '33	WM344

These blueprints are full size. Copies of appropriate issues containing descriptions of these sets can in most cases be obtained as follows:— "Practical Wireless" at 4d., "Amateur Wireless" at 4d., "Practical Mechanics" at 7d., and "Wireless Magazine" at 1/3d., post paid. Index letters "P.W." refer to "Practical Wireless" sets, "P.M." to "Practical Mechanics" sets, "A.W." refer to "Amateur Wireless" sets, and "W.M." to "Wireless Magazine" sets. Send (preferably) a postal order (stamps over sixpence unacceptable) to "Practical and Amateur Wireless" Blueprint Dept., Geo. Newnes, Ltd., 8-11, Southampton Street, Strand, W.C.2.

LETTERS FROM READERS

The Editor does not necessarily agree with opinions expressed by his correspondents.



All letters must be accompanied by the name and address of the sender (not necessarily for publication.)

Entering the S.W. Field

SIR,—Should any of your readers feel cautious in entering the short-wave field, I give a list of stations received on a "straight" set (Tuned S.G.-v-2-Class B) with battery valves and eliminator.

In this list of about sixty-five stations are included Tokio (Japan), Bombay (India), Bandoeng (Java), Havana (Cuba), Sydney (Australia), and U.S.A. stations. There are dozens of other stations from 42 metres upwards which I have received, but have not definitely identified, as they come in at a late hour and do not announce in English, being chiefly South American stations.

Apart from the above, on the 20-metre band I have received dozens of amateurs. On recent Sunday and Monday nights I identified W4BY, W9RUQ, WIDLO, W3APO, W3DQ, W2ZC, W3FIH, W3AWO, W2AIH, W3MD, W2DH, W1GED, U2IJ, and EI9G in half an hour each night. I find it best to sharpen up the aerial circuit, and use phones with one stage of L.F. when tuning in the amateurs, although the majority come in at very good speaker strength (R8-R9).

The secret, so far as I can see, of good short-wave reception is a good average aerial (mine being the ordinary L type, 35ft. with 35ft. top), tuned H.F., not more than .00015 tuning condenser, no band-spreading, but good slow-motion dials, differential reaction, and a variable resistance in the detector H.T. lead to get a minute control of reaction. My only objection to band-spreading is that unless it is used at the extreme minimum capacity of the band-spreading condenser it definitely dampens the grid circuit, even when using a very short wire to join the two condensers; further, it completely upsets the calibration of the set, and is really quite unnecessary if a small tuning condenser is used with a really slow-motion dial.—WILLIAM A. MOSES (Hull).

Logged on a "P. and A.W." Two-valver

SIR,—My friend and I are beginners on the short waves. My friend is a reader of your wonderful journal and he saw in the issue for July 18th the circuit for a two-valve short-waver. We decided to build it, and were surprised with the results. Our coils and choke are home-made, and the valves are detector and power valve, not a pentode as specified. The aerial is 30ft. high and 50ft. long, including lead-in. Our log includes the following stations: Rome 2RO, Belgrade, W3XAL (49.18), W2XE (49.02), W8XK (48.86), W2XAF (31.48), W1XK (31.35), W1XAL (19.67), W3XAL (16.87), GSG (16.86), ORK, VK2ME, HAT4, PCJ, EAQ, and most of the Zeesen stations. Amateur log includes forty to fifty G stations on 40 metres; and on 20 metres:—W3OEZ, W1CHG, W2ZC, W3MD, W3IGL, W4BX, W1FLH, W2AU, and SM5SX.—J. H. ELKIN (Newbridge, Mon.).

Reports and Postage

SIR,—With reference to the letter of Mr. Ismay, G6JI, in the October 3rd issue of PRACTICAL AND AMATEUR WIRE-

LESS, it seems as if G6JI wants to reserve the hobby of S.W. working to "hams" only. I do not agree with his view at all, and I think that a good report is worth a card, especially if a reply coupon is enclosed.

As regards reports always being R7-9, QSA5, I have often heard amateurs giving wrong reports, such as: "I am receiving you R9 + QSA5," and then go on to say: "Please repeat last part again O.M., I did not quite get it." Also there must be thousands of amateurs all over the world who do not always get English QSO's, and therefore are glad to receive reports from S.W.L.'s; also there are many who request reports. It does not seem fair that Mr. Ismay should put S.W.L. in the same class as cigarette-picture collectors; after all, thousands of amateurs have got hundreds of QSL cards as proof of their contacts, so why should the S.W.L. not have them as proof of his reception?

I also regard sixpence, the cost of a reply coupon, to be quite adequate to the cost of card and postage; also, may I say that there are some amateurs who request reports but do not answer them, even when a coupon is sent. For instance, I heard LSX, of the Argentine, on 46.36 m. testing and asking for reports. I sent him one, and also a reply coupon, but I have had no reply yet.

I also sent a report to W1CCZ, of Cape Cod, U.S.A., who sent me a card, and also my reply coupon back, saying: "I thank you for report, and your courteous letter deserves a reply at my expense."

Also, I have had a letter veri from Chief Wireless Op. on board the *Queen Mary*, stating: "Many thanks for your kind observations of the transmissions from this vessel; the data you have supplied will be very useful, and we have filed same for reference." A picture postcard was also sent on behalf of C.W.O.

May I also state that my receiver is a home-built baseboard lay-out of simple design, o.v.l and one-valve amplifier, and not a multi-valve set.—E. R. CRANE (London, W.1).

SIR,—With reference to Mr. Ismay's letter in PRACTICAL AND AMATEUR WIRELESS for October 3rd, I would like to say that I heartily agree with him. The collection of QSL cards is being indulged in by too many people who really do not want them. Indeed, many of these people have a "spasm" of enthusiasm during which they log as many "hams" as possible and send them all a "T9, QSA5, R8" report, usually exaggerated in the hope of pleasing the "ham" in question, and expect the poor man to send them a card in return. I would suggest to "hams" that they restrict card replies to members of recognised national radio societies (i.e., R.S.G.B.), plus any ordinary individuals who happen to send in really useful reports.

I would also like to state that, from my own experience, any report which gives the "ham" a full report of at least twelve occasions of reception, together with really useful information about conditions of

reception, weather, locality and what not, always produces a QSL, whether postage is sent or not, and even if a QSL is not requested! Indeed, I have here a number of cards from "G" amateurs sent to me as a result of such reports; no postage or requests for QSL's having been sent with them.

In reference to SU1CH, this gentleman was heard the other night to say that he would send cards only to transmitters in future if many more junk reports were sent to him. Evidently E. A. J. R. (who got his card so quickly) knows how to "report."—E. DE COLTIGNIES (Prittlewell).

A Good S.W. Log from Ipswich

I ENCLOSE my log of amateur short-wave stations heard recently on the 20-metre band (phone), which may interest other S.W. listeners. My receiver is a home-made battery o-v-l (PM12A and PM1LF), with an indoor aerial of the inverted-L type, the total length being 17ft. The "top" runs approximately north and south.

20 metres. Sunday, September 20th, 1936, 21.40-01.00 B.S.T.—W1GED, W3MD, W3CCW, W3FIH, W2ZC, W2HAK(?), W3QV, W1AJZ, W4ZF, W1DEO, W2HFS, W1GPE, W2ACB, W2FWK, W1ARC, W2MJ, VE3AFD, W1BLO, W3BOP, W3APO, W3DGU, W4BYY, W3CZW(?), W8QBT, W1FLH, W1GJX, W1IUA.

Tuesday, September 22nd, 1936, 22.00-22.52 B.S.T.—VE1DC, VE1BR, W3FIH, W1CCZ, W3EWW, W2ZC, VE1CR, W2HUQ, W3EXC, W8AJZ, VE1CN, W1FLH, W1IRO, W2BNN(?).

Thursday, September 24th, 1936, 23.00-24.00 B.S.T.—W1FLH, VE1BC, W3OX, W3MD, W3FMY, W1CHG, W1DMV, W1AJZ, VE3AFD, W3APO, W2IKV, W1UH, VE1AR, W3EXE, W3CCZ(?), W2DH, W3EWW, VE1DC, W1BLO.

Sunday, September 27th, 1936, evening.—LY1K (Lithuania), VO1I (Newfoundland), W3BFH, VP9R (Bermuda), CT1BY, W4BYY, W8QPT(?), W8GLC, W1FLH.—J. M. GAYE (Ipswich).

CUT THIS OUT EACH WEEK.

Practical Wireless

practical nature suitable for publication in PRACTICAL AND AMATEUR WIRELESS. Such articles should be written on one side of the paper only, and should contain the name and address of the sender. Whilst the Editor does not hold himself responsible for manuscripts, every effort will be made to return them if a stamped and addressed envelope is enclosed. All correspondence intended for the Editor should be addressed: The Editor, PRACTICAL AND AMATEUR WIRELESS, George Nevrnes, Ltd., 8-11, Southampton Street, Strand, W.C.2.

Owing to the rapid progress in the design of wireless apparatus and to our efforts to keep our readers in touch with the latest developments, we give no warranty that apparatus described in our columns is not the subject of letters patent.

N.T.S. CORONATION S.G.3 RADIO

for 5/- DOWN DIRECT to YOU



READY TO PLAY

CASH or C.O.D. Carriage Paid. **84/-**

or 5/- down, balance in 11 monthly payments of 8/-.

● Gives a wide choice of foreign stations with amazing perfection of tone and volume. Built with all high quality components including N.T.S. P.M. Moving-Coil Speaker, SCREENED COILS, high efficiency, S.G., Detector and Pentode output valves. Low H.T. consumption. Full-Vision scale. Wavelengths 200/250; 900/2100 metres. Modern Walnut Cabinet. British valves of guaranteed life. Ready to play. Complete with Oldham Accumulator and H.T. Batteries.

ALL-ELECTRIC BAND-PASS S.G.4 MODEL. Complete in modern vertical console cabinet. Ready to Play. A.C. Mains 200-250 volts, 40/80 cycles. Cash or C.O.D. Carriage Paid 55:0:0 or 5/- down and 11 monthly payments of 10/-.

POST THIS COUPON NOW

NEW TIMES SALES CO.
56 (Pr. W. 19), Ludgate Hill, London, E.C.4.
(a) Please send me your Coronation Receiver (Battery Model) (All-Electric Model), for which I enclose CASH/DEPOSIT
(b) Please send me further details of your CORONATION RECEIVERS. (Strike out which does not apply.)

NAME

ADDRESS

EST. 1924

ELECTRADIX BARGAINS

X-RAY VACUUM DISCHARGE TUBES. 10/- Brand New Government Hospital Surplus. 7" dia. bulb. Big solid Tungsten electrodes. Emission guaranteed. COST £5. SALE 10/-.

LIGHT AND RAY CELLS. Selenium Raycraft, 21/-; Kingston, 15/-; Raycraft outfit with relay and amplifier, 45/-; Photo-Cells, for sound on Film, Television and Ray work, B.T.P. 15/-; R.G.A., 25/-; Beck Angle Prisms, mounted in carrier, 5/6; Micrometer adjusters for lens, 1/-; Eye-pieces with prism and lenses for photo-cell inspection, 12/6. Service Set Headlamps with Battery Holder, 7/6.



TYPE Switchboard with Ammeter, maximum and minimum Auto Cutout Mains Switch and Fusca, Field Regulator, 25/-, or 47/6 the pair.

DOUBLE CURRENT DYNAMOS. D.C., 600 volts 100 m.a., and 6 volts 3 amps., 32/6.

MICROPHONES. 25 models in stock from 1/- upwards. Crystal, Condenser, Mov. Coil, Transverse, Reisz, etc. All cheap.

Illustrated Bargain List "P" free.
ELECTRADIX RADIOS,
218, Upper Thames St., London, E.C.4. 'Phone: Central 4611

REPLIES IN BRIEF

The following replies to queries are given in abbreviated form either because of non-compliance with our rules, or because the point raised is not of general interest.

F. W. B. (Bow, E.). The valves you mention are quite in order, but we cannot guarantee results unless you use the parts named by us.

H. G. C. (Cardiff). Your assumption is quite correct.

B. W. (Sydenham). H.F. instability can cause the whistle, but it may also be due to L.F. troubles. Reverse the connections to the secondary of the L.F. transformer. If this does not cure the trouble the H.F. stage should be examined and the voltages checked.

B. W. (Cranwell). No blueprint is available, but the back numbers describing the receiver are still available, price 4d. each.

W. H. (Bolton). PW48A will prove of use to you as it describes a unit which will work with your receiver.

A. W. B. (Middlesbrough). We hope to publish an article dealing with the subject in the near future.

F. G. F. (Highgate). We hope to describe a receiver of the type mentioned in the near future, if sufficient interest is shown by readers for this type of apparatus.

M. L. (Finsbury Park). We are unable to give you the coil winding details asked for. This is beyond the scope of a reply.

C. H. O. (Perth). We are unable to assist you. The switch cannot be identified from your sketch and we cannot see how it works from your diagram. Can you supply any further details, or send the switch to us for inspection?

J. C. H. (Dartmouth). The Prefect S.W.3 (blueprint PW63) should prove suitable for your requirements.

G. D. (Carshalton). There is no book so far as we are aware which would be of use to you. We suggest you follow our various S.W. articles, and perhaps obtain a copy of the "Television and Short-Wave Handbook."

T. R. (Wolverhampton). We are not familiar with the servicing difficulties of individual commercial receivers and suggest that you communicate direct with makers or their nearest local service agent.

J. C. L. (Portsmouth). We regret that we have not found a satisfactory method of using the A.V.C. feature with the circuit in question. Ample H.F. amplification is desirable in order to obtain satisfactory A.V.C. action.

C. J. T. (Crosskeys). We shall probably design a mains version of the receiver in the near future. We can only suggest that you persevere with the tripping of the receiver in question. Good results can only be obtained when all circuits are correctly aligned.

J. O. (Wainfleet). We cannot trace the valve in question in our files. It would appear to be a very old model designed for a 5-volt L.T. supply.

E. H. (Bow). We have not described a mains unit of the type you refer to. We thank you for your suggestions regarding constructional articles.

F. G. (W.C.1). The P.W. Short-wave Adapter-Converter, described on blueprint PW48A, should be suitable for your set.

J. Fairbrother (Mr. Blackley). Faulty earthing is responsible for the trouble. If you have not earthed the metal panel you should do so, but if this is already connected to earth, your present earth connection is ineffective and you should endeavour to improve it or try a substitute.

O. J. G. (Mansfield). The speaker in question will be perfectly satisfactory with the Lunit receiver.

A. W. H. (Swindon). We think that the best procedure will be for you to add an H.F. stage. A suitable H.F. unit was described in PRACTICAL AND AMATEUR WIRELESS dated January 25th, 1936.

J. H. W. (Haverfordwest). We are not familiar with the servicing difficulties of individual commercial receivers and suggest you communicate with the makers of your set.

THE WIRELESS CONSTRUCTOR'S ENCYCLOPEDIA

By F. J. CAMM (Editor of "Practical and Amateur Wireless") 4th Edition 5/- net

Wireless Construction, Terms and Definitions explained and illustrated in concise, clear language.

From all Booksellers, or by post 5/6 from George Newnes, Ltd., 8-11, Southampton Street, Strand, London, W.C.2.

EASY PAYMENTS

"THERE'S NO PLACE LIKE HOLMES." Monthly Payments

W.B. 37 J	32/6	4/-	7 of 4/5
ROLA F1020 P.M.	38/6	4/-	9 of 4/3
CELESTION SENIOR 9	55/-	5/-	11 of 5/-
MAGNAVOX THIRTY-THREE 75/-	6/10	6/10	11 of 6/10

Any make of speaker supplied.

GRAHAM-FARISH SENSITY SUPER 50/- 4/7 11 of 4/7

GRAHAM-FARISH ALL-WAVE KITS 57/6 5/3 11 of 5/3

SPECIAL—G.E.C. universal mains A.C. or D.C. with M.C. Speaker, complete with valves in cabinet. List price, £8 19s. Our Price 7s. deposit and 11 payments of 7s. 3d.

PARTS FOR ANY SET. ANY MAKE OF SPEAKER. New goods obtained for every order.

Send us a list of parts or valves you require or any speaker or set you may select and we will forward you a definite quotation. Ten years' advertiser in the Wireless Press. Thousands of satisfied customers.

H. W. HOLMES,
New Address:—333, EUSTON ROAD, LONDON, N.W.1.
'Phone: Museum 1414.

ENGINEERS! ARE YOU EARNING LESS THAN £10 PER WEEK?

If so, you cannot afford to carry on without reading our 268-page Handbook. The book explains clearly and definitely many ways of carving out a successful career. Among other things it explains the Services of our unique Appointments Department, outlines Home-study Courses in all branches of Civil, Mechanical, Electrical, Motor, Aero, Wireless, "Talkie," Engineering, Building, Govt. Employment, etc., and gives details of B.Sc., A.M.I.C.E., A.M.I.E.E., A.M.I. Mech. E., G.P.O., MATRIC, and all Exams. We Guarantee—"NO PASS—NO FEE." Whether you be an old hand or a budding apprentice, get this book to-day—FREE and POST FREE. BRITISH INSTITUTE OF ENGINEERING TECHNOLOGY.
409, Shakespeare House, 17/19, Stratford Place, London, W.1.

RECORD

The quality valve in the COMPLETE range
RECORD RADIO LTD., 2/3, Eldon Street, E.C.2

SHORT WAVE NEWS!

The October "BSWL REVIEW" is now on sale, price 6d. It contains the very best Short Wave news obtainable! Read all about what's new in the QSL world, learn the Morse Code as taught by BR25063; refer to the "Blacklist" before sending your reports; study the remarkable lists of DX reported by members and keep up to date with the new stations by securing your copy NOW! It may be obtained at Messrs. W. H. Smith & Sons' bookstalls or 6d., post free, from the publishers, The British Short Wave League, Ridgewell, Halstead, Essex. Particulars of membership may be had on request.

19 BRAND NEW BUY VALVES DIRECT SAVE 50%

Such amazing value only possible by supplying direct to public. You will marvel at the difference in tone to your set. Note these money-saving prices—2-VOLT BATTERY TYPE, H.2, H.L.2, L.P.2, 1/8; Super Power P.2, 2/6 each. Screens and L.F. Pentodes, 3/9 each. A.C. MAINS, 4-VOLT 1 AMP. General Purpose, 3/3; Power 4-cath Screen and L.F. Pentodes, 4/6 each. FULL-WAVE RECTIFIERS, 3/6 each. All valves critically tested before despatch and sent Post Free. Cash with Order or C.O.D. over 10/- Send now.
CLARION RADIO VALVE CO.
(Dept. P.W.3), Tyburn Road, Edlington, BIRMINGHAM.

FREE ADVICE BUREAU COUPON

This coupon is available until October 24th, 1936, and must be attached to all letters containing queries.
PRACTICAL AND AMATEUR WIRELESS, 17/10/36.



QUERIES and ENQUIRIES

The Cathode-ray Tube

"In a recent article on television you mentioned electrostatic and electro-magnetic deflection in connection with the cathode-ray tube used in a television set. I am sorry I cannot understand these terms and should be glad of a brief explanation."—W. C. (Balham).

THE principles of working of the C.R. tube have already been explained in our pages, and it was stated that the electron stream is directed towards the end of the tube, passing on the way two pairs of deflecting plates. These control the movement of the electron beam and there are two methods of carrying out this control. The plates themselves may be joined to voltage sources and the variation of voltage will act as a deflecting medium, or ordinary electro magnets may be situated outside the tube and will act in a similar manner. The subject will be fully covered in future issues, but the above brief explanation will no doubt assist you in understanding the function of the two terms.

Public-Address Equipment

"I wish to build up a small P.A. outfit for the amplification of a dance band at a meeting in a large hall. What volume do I need, and what type of speaker? The apparatus may be required permanently, and I should be glad if you have any designs of apparatus which will suit my requirements."—F. T. (York).

SIX watts should prove adequate if fed into a suitable loudspeaker. We suggest that you read the article published in our issue dated July 4th last, in which we also gave instructions for building up suitable loudspeaker horns for use with standard moving-coil speaker units. Circuits were also given in that article for various types of amplifier, both battery and mains-operated. Alternatively, you could build the Enthusiast's Power Amplifier (Blueprint W.M. 387), or the 5-watt Listener's Amplifier (Blueprint W.M. 392).

Making Push-Pull Transformers

"I have a spare 5-1 ratio L.F. transformer. Could you tell me whether it would be possible to convert this into a Class B by the use of suitable resistances? If so, what value should the resistances be?"—H. M. P. (Tiverton).

IT is possible, although not technically sound, to use two resistors across the secondary of an L.F. transformer of the "straight" type for use in a push-pull

circuit. The two resistors will obviously modify the characteristics of the transformer, and although the arrangement works it does not give nearly such good quality and volume as a correctly-designed push-pull transformer. In a Class B circuit, however, the secondary must be of low resistance, as grid current is permitted to flow and the secondary plays a definite part in the working of this type of amplifier. Therefore, low values of resistance would be required for the improvised arrangement, and in view of the high resistance of the ordinary type of transformer, the signals would be practically short-circuited. The arrangement is not recommended for this type of circuit.

The Best Circuit

"I am a beginner in wireless construction and know nothing about theory. What

RULES

We wish to draw the reader's attention to the fact that the Queries Service is intended only for the solution of problems or difficulties arising from the construction of receivers described in our pages, from articles appearing in our pages, or on general wireless matters. We regret that we cannot, for obvious reasons—

- (1) Supply circuit diagrams of complete multi-valve receivers.
- (2) Suggest alterations or modifications of receivers described in our contemporaries.
- (3) Suggest alterations or modifications to commercial receivers.
- (4) Answer queries over the telephone.
- (5) Grant interviews to querists.

Please note also, that queries must be limited to two per reader, and all sketches and drawings which are sent to us should bear the name and address of the sender.

If a postal reply is desired, a stamped addressed envelope must be enclosed. Send your queries to the Editor, PRACTICAL AND AMATEUR WIRELESS, George Newnes, Ltd., 8-11, Southampton Street, Strand, London, W.C.2.

The Coupon must be enclosed with every query.

is the best set for me to build—the All-Wave Unipen, the B.B.C. Special one-valver, or the Twenty Station loudspeaker one-valver?"—J. A. (Dublin).

THE first-mentioned receiver employed a special all-wave tuner with a pentode valve as detector. The second is a simple one-valve set covering only the medium- and long-wave broadcast bands, with a standard detector valve. The third receiver employs a special valve made by the makers of Hivac valves, and embodies a Class B valve together with the driver. The volume from this is greater than the other two, but the selectivity of the second receiver is the highest. The first receiver covers the short waves in addition to the ordinary broadcast waves and, therefore, offers more entertainment. Furthermore, the pentode ensures that good volume is

obtained. Perhaps from these details you can decide which receiver will provide you with the most suitable entertainment. The first is the simplest from the constructional point of view, and the third is the most difficult, but any of them could be built easily in one evening.

Starting Transmitting

"I am an enthusiastic amateur, and intend to take up the transmitting side. Would you please advise me as to procedure, etc., and whether the cost would be great?"—V. A. M. (Romford).

A THOROUGH knowledge of radio is necessary before you can obtain a licence, but to acquire working knowledge with actual transmitting gear you should first obtain an Artificial Aerial licence. With this you can build a transmitter up to 10 watts and operate on the 20, 40 and 160-metre wavebands, but cannot employ an outside aerial. Write to the Engineer-in-Chief, G.P.O., Radio Section, Aldersgate Street, E.C.4, for an application form. A circuit of the proposed transmitter must be submitted and you must also give the lines of experiment you intend to take up. The fee is 10s. You must not construct any apparatus until the licence is issued.

The Limit All-Wave 4

"Will you please give me particulars of cost, and where to obtain parts and materials for the Limit All-Wave 4 in a recent issue?"—S. J. C. (Ashford), and V. C. (Caterham Valley).

KIT A for this receiver costs £4 16s. 6d. This kit includes all of the components, chassis, etc., and the only additional parts required are the valves, cabinet, speaker and batteries. Messrs. Peto-Scott can supply the complete kit, with or without batteries, valves, etc.

The coupon on page 150 must be attached to every query.

THE ONE AERIAL FOR THE MODERN SET
PIX INVISIBLE AERIAL
 PIX LONDON S.E.1

Highly efficient, self adhesive aluminium strip—gives wonderful pick-up clear of interference—fixed in a jiffy without tools—just press it and it sticks.

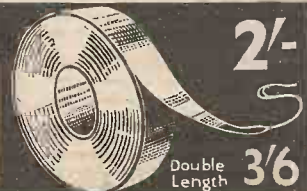

Miscellaneous Advertisements

Advertisements are accepted for these columns at the rate of 3d. per word. Words in black face and/or capitals are charged double this rate (minimum charge 3/- per paragraph). Display lines are charged at 6/- per line. All advertisements must be prepaid. All communications should be addressed to the Advertisement Manager, "Practical and Amateur Wireless," 8, Southampton Street, Strand, London.

RECEIVERS, COMPONENTS AND ACCESSORIES
Surplus, Clearance or Secondhand, etc.

RADIOMART
SHORT-WAVE SPECIALISTS

Announce 1937

SHORT-WAVE MANUAL

Packed with short-wave information and circuits of mains and battery receivers, including straight, superhet and 5-metre transmitters, modulators, etc. Information on transmitting licences, aeriads. Class B amplification, neutralization, superhet alignment, etc. The most comprehensive manual published, written by practical engineers, price 6d., post free 7½d., including catalogue.

1937 Catalogue only (3 times enlarged) price 1½d. post free.

- C**OSSOR 1936. Superferrodyn receiver half price £2/19/6. Stamp for full list.
- T**EISEN screened dual range coils, 2/6. Pair 4/6. Milliammeters, 25ma. upwards, 5/9. Super, 6/9.
- A**MERICAN mains transformers 230 v. fully shrouded, 350/350. 6.3v., 5v., 6/11. Majestic 250/250. 2.5v., 5v., 4/11.
- H**EAVY DUTY mains transformer worth 35/- 350/350. 150 ma.; 4v. 2.5ACT. 4v. 6ACT., 12/6. 465 KC/S., 1F. transformers, 2/11. Telsen Ace, 1/11. RG4, Radiogrand, 2/9. 2mf. 300v. 9d. TILTLY straight line wavelength dials, 3/11. Telsen H.F. chokes, 1/11.
- U**TILITY 2-gang unknob and dial, 3/11; 1,500-volt tubular condensers, all sizes, 6d.
- L**ECTROLYTICS 500-volt 8mf. 1/6; 4mf. 1/6; 4 x 4 1/11; 8 x 8 3/6; 25mf. 25v. 1/-, etc.
- S**MOOTHING chokes, 20 hy. 120 m.a., 3/11; 100 m.a., 2/11; 40 m.a., 1/11.

ALL goods previously advertised are standard lines, still available. Post card for list free.
VAUXILIARY UTILITIES, 163a, Strand, W.C.2. Over Denny's the Booksellers, Temple Bar 9338.

WE BUY for cash, all types of Modern Second-hand Radio Sets, Accessories, etc. Unbeatable Part-exchange allowances for new goods. Bring, send or write.

UNIVERSITY RADIO LTD., 82, Hampstead Road, London, N.W.1. Phone: Euston 3810.

CONVERSION UNITS for operating D.C. Receivers from A.C. Mains, improved type, 120 watts output, at £2/10/0. Send for our comprehensive list of speakers, Resistances and other components.

WARD, 46, Farringdon Street, London. E.C.4. Telephone: Holborn 9703.

PREMIER SUPPLY STORES

SHORT WAVES.

- SHORT-WAVE COILS** 4- to 6-pin types, 13-20, 22-47, 41-94, 78-170 metres, 1/9 each with circuit. Special set of 3 S.W. Coils, 14-150 metres, 4/-, with circuit. Premier 3-band S.W. Coil, 11-25, 19-43, 38-86 metres. Simplified S.W. receiver construction, suitable any type circuit, 2/-.
- COIL FORMERS**, in finest plastic materials, 1 1/2 in. low-loss ribbed, 4- or 6-pin, 1/- each.
- CONDENSERS**, super ceramic S.L.F., 00010, .0001, 2/9 each; double-spaced, 00015, .00025, .00035, 3/- each; with integral slow-motion 00015 tuning, 3/9; 00015 reaction, 2/9.
- SHORT-WAVE KIT** for 1 valve receiver or adaptor, complete with chassis, 3 coils 14-150 metres, condensers, circuit, and all parts, 12/6.
- VALVE GIVEN FREE**. De Luxe Model, 17/6.
- 2-VALVE S.W. KIT**, complete with valves, 19/6.
- 3-VALVE S.W. KIT**, S.G., Det., and Pen. complete with valves, 40/-.
- T**EISEN iron-cored coils W.349, 4/- each.

PREMIER (Reiz Pattern) transverse current microphone, 30/-; transformer, 5/-.

SPEAKERS, MAGNAVOX. Mains energised. '154', 7" cone, 2,500 ohms 4 watts, 12/6. '154 Magma', 5 watts, 25/-; '152', 9" cone, 2,500 ohms, 17/6; '152 Magma', 9" cone, 2,500 ohms, 6 watts, 37/6. 'Magnavox' P.M.s.—'254', 7" cone, 16/6; '252', 9" cone, 22/6. Reliable P.M.s., 10/6; Cossor P.M.s., 13/6.

MAINS TRANSFORMERS. Premier wire-end type with screened primaries.

H.T. 8 & 9 or H.T. 10 with 4v. 4a C.T. and 4v. 1a. C.T., 8/6.

250-250v. 60 m.a., 4v. 1a., 4v. 2a. and 4v. 4a., all C.T., 8/6.

350-350v. 120 m.a., 4v. 1a., 4v. 2a., and 4v. 4a., all C.T., 10/6.

500-500v. 150 m.a., 4v. 2-3a., 4v. 2-3a., 4v. 3-4a., all C.T., 19/6.

Any of these transformers with engraved pane and N.P. terminals, 1/6 extra.

AUTO TRANSFORMERS, step up or down, 60 watts, 7/6, 100 watts, 10/-.

MAINS VALVES, famous Europa 4v. A.C. types, 4/6 each. H.L., L., S.G., Var-Mu-S.G., H.F. Pens., Var-Mu-H.F. Pens., 1-, 3-, and 4-watt A.C. directly-heated output Pentodes. Full-wave rectifiers, 250 v. 60 m.a. A.C./D.C. types, 20-volt, 1.8 amp. S.G., Var-Mu-S.G., H., H.L., and Power.

Following types all 5/6 each. Full-wave rectifiers 350v. 120 m.a. and 500v. 120 m.a. 2½ watt indirectly-heated Pentodes. Frequency Changers, Octodes and Heptodes.

BATTERY VALVES. 2-volts, H.F., L.F., 2/3. Power, Super-Power, 2/9. S.G., Var-Mu. S.G., 4- or 5-pin Pentodes, H.F. Pens., V.-Mu-H.F. Pens., 5/-, Class B, 3/6.

AMERICAN VALVES. Genuine American DUOTRON, all types, 3/6 each. Hytron super quality, 3 months' guarantee, all types, 5/6.

MILLIAMMETERS, moving-iron flush 24" all ranges from 0-10, 5/9. Visual tuning, 6 or 12 m.a., 5/-; Moving coil metres, 2½" 0-1 m.a. 18/6; 3½" 0-1 m.a., 22/6. Multipliers, 1/- each. Westinghouse meter rectifiers, 17/6 each.

ELECTROLYTICS. U.S.A. 4, 8 or 12 mfd. 530 v. peak, 1/9 each. Dubilier, 4 or 8 mfd. 500 v. 3/-; 50 mfd. 50 v., 1/9; 12 mfd. 20 v. 6d.; 25 mfd. 25 v., 1/-; T.C.C. 4 or 8 mfd. 650 v., 4/-; 15 mfd. 50 or 100 v., 1/-; 50 mfd. 12 v., 1/-.

Paper Condensers. W.K., 250 v. working 4 mfd., 2/-; 2 mfd. 1/-, 1 mfd. 6d.; 250 v. working 4 mfd., 2/6; 2 mfd. 1/6. Dubilier 500 v. working 4 mfd., 4/-; 800 v. 4 mfd. 6/-; 2 mfd. 750 v. 3/-.

Wego 450 v. working 1 mfd. 1/-, 2 mfd. 1/9, 4 mfd. 3/-; 700v. working 2 mfd. 2/-, 4 mfd. 3/6; 1,650 v. working 1 mfd. 3/6.

TRANSFORMERS, latest type Telsen R.G.4 (list 12/6), 2/9. Lissen Hypernik Q.P.P. (list 12/6), 3/6.

EELIMINATOR KITS for A.C. Mains. 120 v. 20 m.a., 150 v. 25 m.a., 10/-, tapped S.G. det. and output. Complete Kit with long-life valve rectifier (replacement cost only 2/-).

LISSEN ALL-ELECTRIC A.C.A. S. Grid. Det., Pen. and Rectifier, M.C. Speaker. (List £9.9.0). Our price 65/-.

Potentiometers by well-known makers. All values up to 1 meg. 2/-; with switch 2/6.

GRAMOPHONE MOTORS. Collaro, Gramophone Unit, consisting of A.C. motor, 100-250 v. high quality pick-up and volume control, 45/-; motor only 30/-; Collaro Universal Gramo, 45/-; motor only 30/-; A.C./D.C. with high quality pick-up and volume control, 67/6; Universal Motor only, 49/6; Edison Bell double spring motors, including turntable and all fittings, 15/-; Cosmocord Gramo unit, comprising A.C. motor, pick-up and volume control (list 55/-), 35/9.

ALL POST ORDERS should be addressed to—**JUBILEE WORKS, 167, LOWER CLAPTON RD., LONDON, E.5.**

'Phone Amherst 4723 (Private Branch Exchange). Callers, as usual, to 20-22; HIGH ST., CLAPHAM, S.W.4 (Macaulay 2381).

and 165 and 165a, Fleet St., E.C.4 (next to Anderton's Hotel) (Central 2833).

NOW READY! Send 4d. in stamps for **NEW ILLUSTRATED GIANT CATALOGUE AND VALVE LIST.**

RECEIVERS, COMPONENTS AND ACCESSORIES
Surplus, Clearance or Secondhand, etc.

SOUTHERN RADIO'S WIRELESS BARGAINS. ALL GOODS GUARANTEED AND SENT POST PAID.

SPEAKERS.—Celestion Soundex Permanent Magnet, 10/-; Telsen Permanent Magnet with ten-ratio transformer, 12/6; Blue Spot 99P.M. Extension Speaker, 20/-; 45P.M. Extension Speaker, 17/6; Telsen Loud Speaker Unit, 2/6; all new and boxed.

RECEIVERS.—G.E.C. A.C. D.C. Mains Three-valve sets. Complete with 3 Osram Valves, in exquisite Bakelite cabinet with Osram M.C. Speaker. Ready to plug in to any mains. Fully guaranteed. New, in sealed cartons, £3/5 (list £7/15).

G.E.C. Compact 3-valve Battery Sets complete with 3 Osram valves, moving coil P.M. Speaker in attractive Bakelite cabinet, makers' 1936 series in original sealed carton, 50/- (list £5/10/0).

TEISEN A.C. D.C. MULTIMETERS (latest 1936 type)—5-range for every conceivable test for radio and domestic electrical appliances, 8/6 each.

COILS.—TEISEN (1936). Iron-cored Coils, Type W349, midget size, 4/-; type W478 (twin), 9/- pair; type W477 (triple), 16/-; type W476 (triple) superhet selector and oscillator, 16/- set. All Ganged Coils are Mounted on Base with switch. I.F. Transformer Coils W482, 5/-; Telsen Dual Range Coil with variable series condenser W70, 4/-.

MICROPHONES.—Ace (P.O.) Microphones, complete with transformer, perfect with any type of receiver, 4/6.

TRU-OHM RESISTANCES.—1 Watt. Wire ends colour coded and marked; 36 assorted capacities on card, 6/-.

AMERICAN VALVES.—A full range of valves for all American sets at 7/- each. Brand new, guaranteed.

REPAIRS.—Any type of Receiver, American, British, etc. Repaired by Expert Staff.

SOUTHERN RADIO BRANCHES.—271/275, High Road, Willesden Green, N.W.10; 46, Lisle Street, W.C.2. All mail orders to 323, Euston Road, N.W.1.

SOUTHERN RADIO, 323, Euston Road, London, S.W.1 (near Warren Street Tube). Phone: Euston 3775.

NEW RECEIVERS, COMPONENTS AND ACCESSORIES

RADIO AND ENGINEERING SUPPLIES.

TUBULAR Condensers, by well-known manufacturer, .002, .01, .05, .02, 3d.; .1, 25, 5d.

ERIE Resistors, 1-watt, all values, 4d.

SHORTWAVE Plug-in coils, fit standard valve-holder, 13-26, 22-47, 41-94 metres, 4- or 6-pin, 1/9d. each. Super Quality 2/6d. each, set of three, 7/-.

SHORTWAVE Condensers, .0001, .0015, .0002, .00025, 1/11d. With 10-1 slow-motion and 3in. dial and knob, 2/11d.

SHORTWAVE all brass, slow-motion condensers, .0001, .00015, 4/3; .0002, .00025, 4/9d.

SHORTWAVE Low-loss chokes, 10-100 metres, 7d. each.

SHORTWAVE Straight vision drive, 4/9d.; dual ratio, 8-1 and 100-1, 5/6d.

VALVE Holders Chix Chassis mounting, 4- and 5-pin, 3d.; 7-pin, 4d.

AMERICAN Valves, first grade Hytron, three months' guarantee, all types, 5/-; Line cords, 2/6d. each.

SHORTWAVE Bargain lists now available, send stamp.

EELIMINATORS, Speakers, kits, etc., write for lists.

HIVAC Valves, complete stock, send for list, liberal discount to the trade.

TRADE Enquiries, send stamp and trade heading for latest lists.

RADIO AND ENGINEERING SUPPLIES, 88, Edgware Rd., London, W.2. Phone: Paddington 6652.

BANKRUPT Bargains. List free. All goods new. Any set supplied. Telsen 6v. A.C. superhets complete, £5/10/0. Cossor D.C. 3v. S.G. 75/0. Full stock of Ferguson Pilot, Traphonic superhets, including All-wave. Get my prices and part-exchange offers. Large stock of speakers, replacement valves of all types, large variety components. Kits for any circuit. Following second-hand to clear: PA Amplifier with turntable and microphone and 12gn. F.I. projection speaker, £7/10/0. Amplion 5v. A.C. superhet as new, £5/10/0. Whatever you require write Butlin, 6, Stanford Avenue, Brighton, Preston 4030.

HULBERT for Quality Surplus Speakers. All Music Lovers should write for List of amazing bargains. Prices from 8/6 brand new. Made by best known British maker.—Hulbert, 6, Conduit Street, W.1.

LOUDSPEAKER REPAIRS

REPAIRS to Moving Coil Speakers, Cones and Coils fitted or rewound. Fields altered. Prices Quoted including Eliminators, Loud-speakers Repaired, 4/-; L.T. and Speech Transformers, 4/- post free. Trade invited. Guaranteed. Satisfaction. Prompt Service. Estimates Free. L. S. Repair Service, 5, Balham Grove, London, S.W.12. Battersea 1321.

RADIO CLEARANCE

63, HIGH HOLBORN, W.C.1:

TEL.: HOLBORN 4631.
The Mail Order House with the World-Wide Reputation. Quality goods and satisfaction assured. ANNOUNCING GREATER BARGAINS THAN EVER IN GUARANTEED RADIO.

PRICE £8. 19. 6 WAVE A.C. RECEIVER, wave-range 15-2,000 metres. 91" Auditorium speaker. Provision for external speaker and pick-up. Handsome Walnut cabinet of modern design. Brand new. Made for export. To sell at 20 gns.

50/- Lissen Band Pass 3 Kit, sealed, with valves. Exclusive British rights held by us for Constructrad Short-Wave Kits. All Kits supplied valves free. Five interchangeable coils, covering a range from 15-600 metres. Complete set, not a converter.

29/6 One-Valve Battery Kit.

37/6 Two-Valve Battery Kit.

37/6 One-Valve A.C./D.C. Kit.

49/6 Two-Valve A.C./D.C. Kit.

£5. 19. 6 Ever Ready 5-VALVE BATTERY S/H. Incorporating A.V.C., large square-type dial, provision for pick-up and extension speaker. Listed 12 gns. Stocks are limited, order at once to avoid disappointment.

39/6 LISSEN 4-VALVE A.C. RECEIVER. Complete with valves. P.M. Moving-Coil speaker, handsome horizontal cabinet. S.G. Det. Pen. Rectifier.

70/- LISSEN 4-VALVE A.C. BAND PASS RECEIVER. A quality job listed at £9 15s. Sent out Aerial tested, complete with valves.

55/- LISSEN BATTERY BAND PASS RECEIVER, complete with valves.

35/- LISSEN 3-VALVE, PLUS BARRETA D.C. RECEIVER. Fitted handsome horizontal Walnut Cabinet. Complete with valves.

35/- ALBA H.F. PEN. DETECTOR, PEN., 3-VALVE CHASSIS, brand new fitted Mullard valves.

75/- A.C./D.C. AMERICAN MIDGET, 5-valve type, a real quality job, Jensen Moving Coil Speaker, etc., brand new, boxed.

BRUCE MAINS TRANSFORMERS AND CHOKES, standard for the season, finest made. British and guaranteed.

8/6 250-0-250, 80 m.a., 2-0-2 volts, 2.5 amp., 2-0-2 volts, 4 amp.

10/6 350-0-350, 120 m.a., 2-0-2 volts, 2.5 amp., 2-0-2 volts, 4 amp.

12/6 350-0-350, 150 m.a., 2-0-2 volts, 2.5 amp., 2-0-2 volts, 4 amp., 2-0-2 volts, 2 amp.

17/6 500-0-500, 150 m.a., 2-0-2 volts, 2.5 amp., 2-0-2 volts, 6 amp., 2-0-2 volts, 2 amp., 2-0-2 volts, 2 amp.

8/6 H.T.8 Transformer, 250 volts, 60 m.a., 2-0-2 volts, 4 amp.

17/6 Ditto with H.T.8 Metal Rectifier.

ALL TRANSFORMERS ARE FULLY SHROUDED. MAINS CHOKES

4/6 40 ma, 30 hys.

6/- 60 ma, 40 hys.

10/6 150 ma, 40 hys.

21/- 250 ma, 15 hys.

6/- 60 ma, 80 hys, 2,500 ohms for speaker replacement, etc.

12/6 Special Clearance Choke, 250 ma, 12 hys, 100 ohms heavy duty type interleaved windings, etc. Cannot be repeated.

TRIAD AMERICAN VALVES, highest quality. All types 5/6 each as follows: 01-A, 24A, 27, 30, 31, 32, 33, 35, 37, 38, 39, 41, 43, 45, 46, 47, 53, 55, 56, 57, 58, 59, 71A, 75, 78, 80, 6A6, 1C6, 6F7, 2A3, 5Z3, 12A7, 6A7, 6C6, 6D6, 12Z3, 25Z5.

All these valves carry a 90-day guarantee and free replacement provided that the filament or heater is intact and the glass is not broken when returned to us.

3/6 Lissen Class B Valves brand new, boxed.

2/6 8 mfd. and 4 mfd. ELECTROLYTICS, 450-volt working, 500 volt peak, well-known make.

6d. 1 Watt Wire End Resistances, well-known make, all values.

1/- 50 mfd. 12 volts working condensers. Well-known manufacture.

1/3 50 mfd. 25 volt working condensers. Well-known manufacture.

1/6 50 mfd. 50 volt working condensers. Well-known manufacture.

(Continued in column two)

"QUALITY"



Special 6-VALVE BAND-PASS SUPERHETERODYNE

Price complete with B.V.A. valves £6 : 10.

Special designed and built for high quality radio/gram work. SPECIAL FEATURES: Reinforced stout steel chassis. High class components by well-known makers of acknowledged reputation used throughout. Fitted with attractive and specially large full-vision dial, glass fronted, and supplied complete with cathodeon and fittings. Separate illumination automatically switched in for radio/gramophone.

CIRCUIT DETAILS: Inductively coupled band-pass filter, triode-hexode frequency changer, band-pass I.F.T. coupled I.F. amplifier, I.F.T. coupled to diode detector. D.A.V.C. applied to preceding valves. I.F. amplifier capacity coupled to output pentodes 3-34 watts undistorted. Variable tone control and volume control operate on both radio and gramophone. Alternative triode output PX4 or AC044 10s. extra.

All receivers supplied complete with valves, knobs, pilot lamps, leads, mains cable and plug. 12 months' guarantee. Deferred terms on application to London Radio Supply Co., 11, Out Lane, E.C.2.

MCCARTHY RADIO LTD.
44a, Westbourne Grove, Bayswater, W.2

Telephone: Bayswater 3201/2

(Continued from column one)

1/- 25 mfd. 50 volt working condensers. Well-known manufacture.

3/11 8+8+4 Electrolytic cardboard condensers, wire ends 450 volt working.

1/11 0 plus 6, 450 volt working, electrolytic condensers, metal case, wire ends. By well-known manufacture.

2/6 14 plus 8 ditto.

1/- 25v. 25 mfd. electrolytic condensers, tubular type. By well-known manufacture.

10/6 P.M. MOVING COIL SPEAKER, 6" cone. By well-known manufacture.

13/6 P.M. MOVING COIL SPEAKER, 7 1/2" cone. By well-known manufacture.

3/6 MULTI-PURPOSE VALVE suitable for H.F. Pentode. List 21/-.

2/- LISSEN 125 kc/s I.F. TRANSFORMER, fully screened.

2/- G.E.C. 110 kc/s I.F. TRANSFORMER, fully screened, with trimmers. Midget type.

6d. TUBULAR CONDENSERS, wire end type, all sizes up to .1.

1/6 LISSEN CENTRE-TAPPED CHOKES. Brand new, boxed.

1/- LISSEN INTER-VALVE CHOKES. Brand new, boxed.

5/11 MIDGET 2-GANG '0005 CONDENSER, fully screened, top trimmers. By well-known manufacture.

Hours of Business: 9 a.m. to 7 p.m. Saturdays, 9 a.m. to 1 p.m.

All orders value 5s. and over, post free.

Orders under 5s. must be accompanied by a reasonable amount for postage.

Enquiries, 11d. stamp, if reply expected.

RADIO CLEARANCE

63, HIGH HOLBORN, W.C.1.

TEL.: HOLBORN 4631.

VALVES

3s. EACH any popular type of American valves. 90 days' guarantee. Orders 10/- or over Carriage Paid. Satisfaction or Money Refunded immediately. **RADIOGRAPHIC LIMITED**, 60, OSBORNE STREET, GLASGOW, C1.

VALVES. By well-known manufacturer. Complete range of Battery, A.C. Mains, Rectifiers. Brand new stock with six months' guarantee. 2 volt Detector, 2/3, Power, 2/9, Screen Grid, Pentode, H.F. Pentode, 5/-. The following American type valves, fully guaranteed, at 5/6 each: No. 80, 42, 43, 57, 58, 77, 78, 6C6, 6D6, 25Y5, 25Z5. Write for other prices to: Dulci Electrical Co., Ltd., 7, Lizard Street, London, E.C.1.

SHORT WAVES

SHORT WAVE on a crystal set. Full building instruction and crystal, 1/2 post paid.—Radiomail, Tanworth-in-Arden, Warwickshire.

NEW RECEIVERS, COMPONENTS AND ACCESSORIES

RADIO BARGAINS

AMAZING Prices. New and Shop-sold Mains and Battery Sets. Components, American, English Valve replacements. All-Wave Superhets, Listed at £11/11/-. My Price £8/18/6. All-Wave Radio Gram. Chassis, Valves and Speaker listed at £8/10/-. My Price £6/12/6. Lotus Midget AC/DC MC Speakers, 65/-. Stamp for list.—LITTLER, 2, Barras Lane, COVENTRY.

POPULAR American Valves. Guaranteed 3 months, 4/3d.; 6 months, 7/0d. Resistors, 1w., 6d.; 2w., 8d. Tubular Condensers, 6d. to .1. Mica, 8d. to .001. All-wave A.C./D.C., 6v., £8/8/0d.; 7v., £9/15/0d. Midgets, 65/0d. Satisfaction Assured. Radio Supplies, 74, Lawson Street, Darlington.

MISCELLANEOUS

WESTERN ELECTRIC Microphones, 1/6 each, post free; Transformers to match, 1/3; 500 clearance lines, catalogues 3d. each.—J. Bearch, 107, Upper Street, London, N.1.

MOVIES at Home. How to make your own Projector. Particulars free.—Moviescope (L) Pear Tree Green, Dodinghurst, Essex.

DAVENSET Accumulator Charger, Type MGC3. Unused. Offers wanted.—44, Cowley Road, Oxford.

FOR Sale: "Celestion" Senior 9. As new, 35/0. Cost £2/15/0.—F. G., 28, Terront Rd., N.15.

YOU CAN USE YOUR SPARE TIME to Start a Mail Order Business that quickly brings you a full time income. Follow the lead of others who are averaging £12 per week net profits. Get away from a drudging routine job—join the big-money class. No previous experience necessary. Few pounds capital only needed. No samples or outfits to buy; no rent, rates or canvassing. New method makes success certain. Write to-day for FREE BOOKLET to Business Service Institute (Dept. 879c), 6, Carmelite Street, London, E.C.4.

HEADPHONES. BROWN, G.E.C., B.T.H., Nesper, H. Sterllus, Ericson, Marconi, Telefunken, etc. from 2/6 pair. Postage 6d. List free. **CRYSTAL SETS.** Complete. Guaranteed. Burne-Jones, 5/6. Ditto, double circuit, 8/- Large P.O. type, 10/-. Crystal detector, Complete parts, 1/- Sensitive permanent detector, 1/6.—Post Radio, 183, Caledonian Road, London, N.1.

WE WILL MAKE A GENEROUS ALLOWANCE on your old set or components in part exchange for any new receiver or Peto-Scott kit. Write for FREE EXPERT ADVICE before making your final choice. You are then assured of COMPLETE SATISFACTION. Prompt delivery of all the latest models.—R. Wigfield, Furlong Road, Goldthorpe, Yorks.

Varley

FOREMOST AS PIONEERS

FOUR NEW CIRCUITS. We have recently published four new circuits which are giving excellent results with our new ganged units. No. 1 (BP 111) Mains Superhet for 110 k.c. No. 2 (BP 112) Battery Superhet for 465 k.c. No. 3 (BP 113) Three-valve mains receiver with band-pass tuners. No. 4 (BP 114) Screened Grid Battery Three with Pentode. Blueprints now ready (BP 111, BP 112, BP 113) price 6d. BP 114 3d. post free.

ACE OF THE BLACK CROSS

The War-Time Adventures
of ERNST UDET

Germany's greatest living Air Ace and
member of the famous Richthofen Circus.

TOLD BY HIMSELF

This is the Authentic Story of his
Adventurous Life in the Desperate
Fighting that Marked the Final Stages
of the War in the Air. It tells of
Miraculous Escapes from Death, and
of the Bitter Struggles of Germany's
War Birds in a Country Disrupted by
Revolution and the Aftermath of War.

Other Special Contents of the
November AIR STORIES include:

FOR SERVICES RENDERED, by
G. M. Bowman.

RAIDERS OF THE REBELLION,
by Hugh Standish.

ONE MAN'S WAR, by Campbell
Hughes.

SPIES FLY HIGH, by Capt. J. E.
Gurdon.

IT FLEW BY NIGHT, by Russell
Mallinson.

THE NOVEMBER AIR STORIES 7^p

At all Newsagents and Bookstalls, or by
post 9d. from the Publisher, George
Newnes, Ltd., 8-11, Southampton Street,
Strand, London, W.C.2.

George Newnes, Ltd.

NEWNES BOOKS on WIRELESS

Special free book repeat offer—
see foot of this advertisement.

THE WIRELESS CONSTRUCTORS ENCYCLOPÆDIA

By F. J. GAMM

Wireless terms and definitions stated and explained in concise,
clear language by one of the best-known and most popular designers
and writers on the practical side of wireless construction. Profusely
illustrated. A veritable treasure of wireless knowledge.

5/- net

(5/3 post free)

FIFTY TESTED WIRELESS CIRCUITS

By F. J. GAMM

Modern circuits of practically every type from crystal to superhet.
Diagrams and instructions for assembling and wiring. Details of
components and notes on operation.

2/6 net

(2/10 post free)

THE OUTLINE OF WIRELESS

By RALPH STRANGER

Here is a book which covers the theory and practice of Wireless
Reception from A to Z, and makes everything plain even to the
most "non-technical" reader.

WORLD-RADIO: "Step by step, line upon line, precept upon
precept, it teaches you everything you want to know about wireless."

816 pages: Lavishly Illustrated.

8/6 net

(9/- post free)

THE MATHEMATICS OF WIRELESS

By RALPH STRANGER

This brilliant and experienced writer on Wireless has a happy
knack of making even the driest and most abstruse topic interesting
—and amusing! He has a characteristic way of handling mathe-
matics which appeals irresistibly to those to whom previously the
subject has seemed both difficult and dull.

5/- net

(5/5 post free)

FREE In order to introduce our wireless
books to the greatest possible market
and to encourage the buying of tech-
nical books generally, we recently offered a free copy
of the famous wireless text book "Wireless for the
Man in the Moon" (2s. 6d. net) to all purchasers of
wireless books from our list to the value of not less
than 5s. So many people have written to us making
application for this book since our offer was closed,
that in fairness to all kind enough to be interested we
are extending the offer until October 31st. Order now
from the above list and make sure of this delightful
volume. Mark your envelope "Wireless Books Offer."

Book Dept., 8-11 Southampton Street, Strand, London, W.C.2

NEWNES : LONDON

FREE BLUEPRINT NEXT WEEK

Practical and Amateur Wireless

3^D
EVERY
WEDNESDAY

Edited by F.J. CAMM

a GEORGE
NEWNES
Publication

Vol. 9, No. 214
October 24th, 1936.

AND PRACTICAL TELEVISION

*Special
Beginners'
Supplement*

The
**Detector
Stage
Explained**

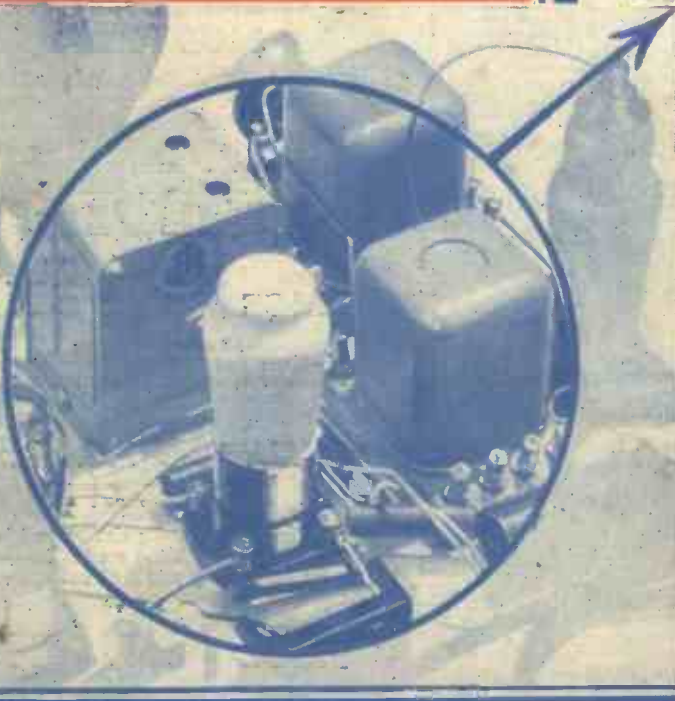

EVERYMAN'S WIRELESS BOOK

By F. J. CAMM (Editor "Practical and Amateur Wireless," etc.)

A Radio Consultant for the Listener, Expert and Amateur Constructor, explaining the Operation, Upkeep and Overhaul of all Types of Wireless Receivers, with Special Chapters on the principles of Radio Telephony, Installation, and Systematic Fault-finding.

From all Booksellers only 3/6 net, or 3/9 post free from

GEORGE NEWNES, LIMITED, 8-11, Southampton St., Strand, LONDON, W.C.2.

With
200

Illustrations



ADVT.

COSSOR 5-VALVE

SUPERHETS *for*

A.C. & D.C./A.C. Mains Operation

PENTAGRID
FREQUENCY
CHANGER

DOUBLE DIODE
TRIODE 2ND
DETECTOR
AND AMPLIFIER

AUTOMATIC
VOLUME
CONTROL

THESE powerful Superhets incorporate all those advances which mean certain and satisfactory reception of a large number of home and continental programmes. Stations on adjacent wavelengths can be separated with ease. Effects of 'fading' are obviated by the use of Full Automatic Volume Control. Distortionless rectification is assured by a Double Diode Triode, whilst the combination of a High Slope Power Pentode and a carefully matched Energised Moving Coil Speaker ensure adequate volume with fine reproduction.

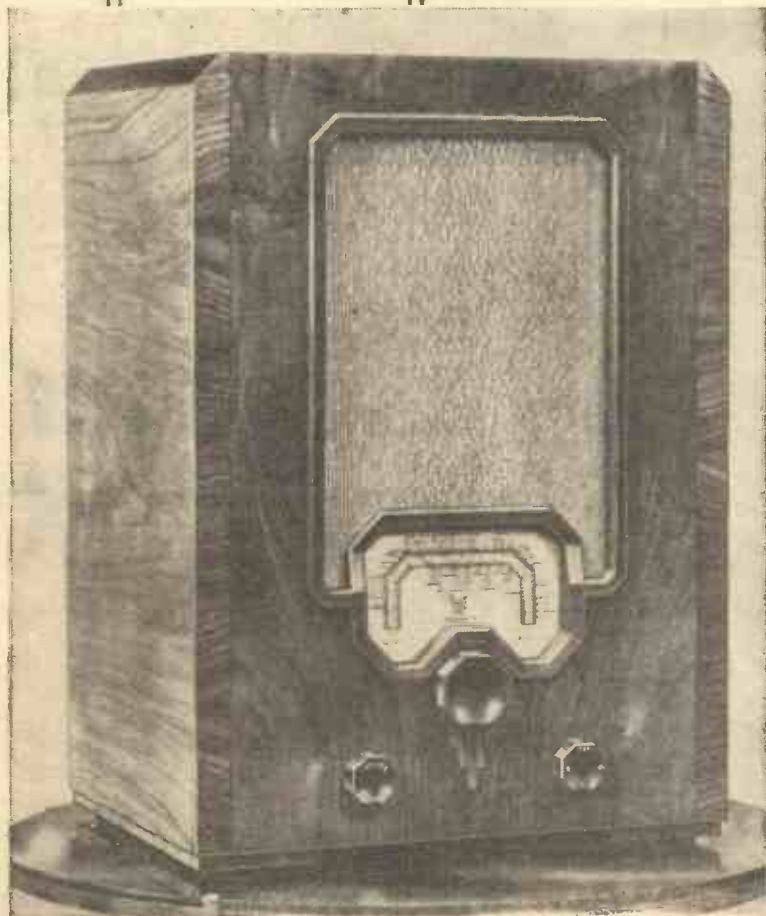

5-VALVE A.C. MAINS MODEL 375

Five valves (including Rectifier). Single-knob Tuning. Illuminated Wavelengths Scale with station names. Combined Radio and Gramophone Volume Control. Tone Adjustment. 8" Energised Moving Coil Speaker. Magnificent Walnut Cabinet. 19½" by 14½" by 11½". For A.C. Mains only, 200-250 volts (adjustable), 40-100 cycles.

PRICE **9½ GNS**

Hire Purchase Terms:

12 months: 17/6 deposit and 12 payments of 17/3
18 months: 17/6 deposit and 18 payments of 12/6

5-VALVE D.C./A.C. MAINS MODEL 375U

Specification generally similar to Model 375, but for operation on D.C. 200-250 volts (adjustable) and A.C. 200-250 volts (adjustable), 50-100 cycles.

PRICE **10 GNS**

Hire Purchase Terms:

12 months: 18/6 deposit and 12 payments of 18/-
18 months: 18/6 deposit and 18 payments of 12/9

Prices do not apply in I.F.S.

A. C. GOSSOR Ltd., Highbury Grove, London, N.5.

THE PICK of the PROGRAMMES

Concert from Torquay

IRENE BAKER (soprano) will be the vocalist in the concert by the Torquay Municipal Orchestra, conducted by Ernest W. Goss, to be broadcast from the Pavilion, Torquay, on October 27th.

Through the Mond Works

ON October 30th, in the Welsh programme, an interesting microphone tour of the Mond Nickel Works at Clydach,

MAKE THESE DATES
WITH YOUR RADIO

Organ Recital from Llandudno

DAVID CLEGG will give an organ recital from the Winter Gardens Pavilion, Llandudno, on October 26th, in the Welsh programme. Mr. Clegg is one of the few

IN THE H.M.V. STUDIO.



Our illustration shows the Ballyhooligans discussing the score of their new H.M.V. record, a quick-step medley entitled "American Tour," which is released this month.

organists in this country to have a small cinema Compton organ installed in his home.

Swansea, will be broadcast. Listeners will be given a sound-picture of the processes involved in the production of pure nickel. They will also hear something of the social life of the works, and the Male Voice Choir will give a short programme of music.

Massed Bands from Leicester

THE League of Bands Association have chosen Granby Hall, Leicester, for its first Championship Contest to which Band Associations in different parts of the country send their strongest representatives. The massed bands will be heard in a popular programme from the Midland Regional on October 31st. C. A. Anderson, Director of Music to the Leicester Festival, is in charge of the contest.

Falkland Islands Programme

TURNING from the scenes of mutiny which occurred on some Austrian light cruisers at Cattaro, listeners on November 1st will hear a feature programme constructed by that great writer on naval matters, "Taffrail," based on the naval actions which took place between squadrons of the German and British navies at Coronel and the Falkland Islands in 1914.

Variety from Peterborough

A POPULAR variety programme will be broadcast on October 28th from the Empire Theatre, Peterborough. It is an independent theatre, and usually provides an excellent and lively bill.

Coventry Hippodrome Orchestra

CHARLES SHADWELL is to be the guest conductor of this orchestra for the studio performance on October 25th, which will be given in the Midland Regional programme.

"Advertising April"

BOURNEMOUTH Little Theatre Company will broadcast for the first time on October 24th in the play, "Advertising April," by Herbert Farjeon and Horace Horsnell. The cast will come to Bristol for the final rehearsals, and the play will be broadcast in the Bristol studios.

Orchestral Concert from Swansea

THE Swansea Festival Orchestra, conducted by Joseph Lewis, will broadcast from the Brangwyn Hall, Swansea, on October 27th. The vocalist will be Astra Desmond (contralto).

Oxford New Theatre Orchestra

A LIGHT programme, including a selection of famous variety songs, will be heard from the Oxford New Theatre, which puts on opera and musical plays with London companies during term time. The orchestra is under the direction of William Brightwell.

Opera from Leicester

LEICESTER Choral and Dramatic Society, which has a chorus of about 200, will be heard in the first act of "Carmen," which they are giving at the de Montfort Hall, Leicester, on October 24th. This broadcast will be given in the Midland programme.

Male Voice Choir

THE Armstrong Siddeley Male Voice Choir will give a programme of part-songs on October 25th. Its first broadcast early in the year. Formed in 1919, the Choir has had notable successes at Midland Festivals, and was second in London. Sydney J. Wisdom has had two periods as Conductor—from the Choir's foundation until 1923, and again since 1931.

"Bands Across the Channel"

LESTER PENDLETON and his Band, who play at the Marina Ballroom, Penarth, will take part in a programme entitled "Bands Across the Channel," on October 27th. The other band which listeners will hear will be Al Durrant and his Blue Boys, from Bristol.

"Intermission"

THE B.B.C. Variety Orchestra, conducted by Charles Shadwell, will give a thirty-five minute programme entitled "Intermission," from the National on October 27th, and Regional on November 16th. The orchestra will be heard as soloists and in novelty items especially arranged to show the quality of the various sections. "Intermission" will bring to the microphone at regular intervals a series of bright orchestral programmes of the type in which Charles Shadwell made his name at the Coventry Hippodrome.

Carl Rosa Opera Company

A PERFORMANCE of Pietro Mascagni's opera, "Cavalleria rusticana," by the Royal Carl Rosa Opera Company, will be broadcast from the Prince's Theatre, Bristol, on October 31st. The opera will be conducted by Charles Webber, and the principal parts will be taken by John Torney, George Hancock, Elisabeth Aveling, Winifrede Ingham, and Pauline Maunder.

SOLVE THIS!

PROBLEM No. 214.

The quality of reproduction suddenly deteriorated in Gordon's A.C./D.C. receiver, and there was a drop in volume. After finding that the valves and voltages were in order, an extension speaker was connected across the primary terminals of the output transformer attached to the receiver's energised speaker. Normal reception was obtained on the extension speaker. What was the trouble? Three books will be awarded for the first three correct solutions opened. Address your solutions to the Editor, PRACTICAL AND AMATEUR WIRELESS, Geo. Newnes, Ltd., 8-11, Southampton Street, Strand, London, W.C.2. Envelopes must be marked Problem No. 214 in the bottom left-hand corner, and must be posted to reach this office not later than the first post on Monday, October 26th, 1936.

Solution to Problem No. 213.

The high current consumption and hum were due to a short-circuit inside the condenser connected across the bias resistance of the output valve.

The following three readers successfully solved Problem No. 212, and books are accordingly being forwarded to them: F. L. Medhurst, 50, Sycamore Ave., Newport, Mon.; L. J. H. McKay, Old Fyncastle, Pithochry, Perthshire; E. Fisher, 33, Freetch Street, Oldbury, Nr. Birmingham.

THE RECORD ALL-WAVE THREE

Preliminary Details of My Special All-wave Set for Beginners, a Blueprint of which will be Given Free with Every Copy of Next Week's Issue. By F. J. CAMM

THE most remarkable development in radio of recent years has been in connection with all-wave receivers. A few years ago short-wave listening was confined to a few amateurs, and the industry did not cater too well for their needs. They were left to experiment with tuning coils and other components, for those designed for medium and long-wave reception were quite unsuitable, as a different technique applies to reception below 100 metres.

There is little wonder then that interest in it flagged and that development was slow. The work of the amateur, however, has been extremely valuable in providing manufacturers with important data for the design of special components. The all-wave receiver has, if I may so put it, been gathering momentum during the past two years, with the result that at this year's Radio Show the all-wave receiver was in the majority. The demand has been enormous, and it is growing. I keep a special file of letters from readers which contain suggestions for future designs, and the section dealing with all-wave sets has so grown in volume during the past six months that it now demands a special file to itself. I have within recent months described several all-wave receivers, but I have been inundated with correspondence from beginners who have asked for a set of simplified construction but of the same standard of design and performance which typifies all of the PRACTICAL AND AMATEUR WIRELESS receivers and enables me to issue a free advice guarantee. Particularly is this valuable if you are a beginner, for you will find it an expensive business if you have to call in the local radio dealer to track down your mistakes.

Ensuring Satisfactory Reception

I save you that expense and that bother. If your receiver does not work you may send it to me. I am responsible for the design, and I gladly accept the responsibility of ensuring that you get satisfactory reception. You must, however, deal direct with me. I cannot undertake to service sets sent to me by dealers, for the excellent reasons I have stated in other issues.

In order to meet this large demand, I have departed from the system of construction with which my name has been associated from the start of this journal—chassis construction. I was the first to use a chassis many years before this journal started. I was the first to make that system available to home constructors so that they did not have to buy expensive tools to work in aluminium or iron. But in recent months many suggestions have been put to me that there is a vast number of constructors who prefer the baseboard style of construction, and for whom I have not hitherto catered. I am told by these readers that they hesitate to build a chassis receiver because they will inevitably make mistakes in their early essays in wireless construction and that they therefore prefer to have all of the components on one surface ready for checking, and for rapid removal and changing, as well as for simplified



wiring. I must remember, too, that a new generation of constructors enters our ranks every year.

Free Blueprint

I have great pleasure, therefore, in informing them that the RECORD ALL-WAVE THREE, free blueprint for which will be given next week, together with full instructions and illustrations for building, will be of the baseboard type. I await the results of my experiment with great interest, for you will agree that it is an experiment to depart from a system which has been welcomed by so many thousands of constructors. If, as I am led to believe, there are an equal number of constructors who prefer baseboards, the Record All-wave Three will be an eminent success. For it is equal in performance and in many ways superior to anything I have done before. I will concede at once that it is easier to build and certainly quicker. Nothing has been sacrificed from the point of view of performance or design, and any constructor who elects to build it will be amazed at the enormous range of it, for it brings in transmissions from every quarter of the globe. I want to encourage the beginner, and he may rest assured that my advice and service are at his command for the asking.

A point which every constructor will appreciate is that the coil unit is self-contained, for it not only includes coils and switches, but is fitted with an aerial and earth terminal socket strip also. It covers the following wave ranges—12.5 to 29 metres—28 to 62 metres—200 to 550 metres—and 850 to 2,200 metres.

Within the compass of those wavebands you have an almost illimitable choice of programmes in all the tongues of the earth merely by the operation of a few controls, the manipulation of which are within the capabilities of the veriest tyro.

Simple Connections

No terminals are employed for connection to the various batteries, etc., all connections being made direct

(Continued on page 174)

The Burghead Transmitter

THE B.B.C. Burghead transmitting station was opened by Sir Murdock MacDonald, M.P., on Monday, October 12. The highlands of Scotland present a particularly difficult problem from the broadcasting point of view owing to the heavy attenuation of wireless waves which is caused by mountainous country. It is fortunate, therefore, that a large part of the population which is not served by the Scottish Regional and Aberdeen transmitters is distributed round the coast of the Moray Firth, and so can be reached by paths of much lower attenuation over the sea and low-lying country from a transmitter situated on the coast.

The site chosen, which proves satisfactory in all these respects, is situated at Burghead on the coast of the Moray Firth about nine miles from Elgin and ten miles from Forres.

The Aerial

The most prominent external feature of the station is the mast-aerial, which is already a familiar landmark. There are no actual aerial wires, as the mast itself is the aerial from which radiation takes place. This type of aerial is usually described as an

waves. If, therefore, the "sky-wave" is made as weak as possible, and the "ground wave" as strong as possible, the maximum non-fading range will be obtained.

It should be explained that the use of this anti-fading aerial does not mean that there should be no variations in the strength of reception from the new transmitter. However, the range at which serious fading is likely to occur will be greater than it would be if one of the older types of aerial were used.

The high-frequency energy from the transmitter is fed by means of a concentric

of rough-hewn natural stone. It has a single storey, except for the office block at the front, which has two storeys.

The Transmitter

The transmitter is similar in all respects to that at Lisnagarvey, and the general circuit design of both these transmitters resembles that of the long-wave National transmitter at Droitwich, the same system of modulation being employed. The power which the transmitter delivers to the aerial is 60 kilowatts and the wavelength is 391.1 metres (767 kc/s), the same as that of the Scottish Regional transmitter at



A general view of the Transmitting Hall at Burghead, and, on the left, the building and single mast aerial as seen from the entrance gates.

"anti-fading" aerial—that is to say, it is designed to extend as far as possible the service area of the transmitter, by radiating the maximum amount of energy in a horizontal direction (the "ground wave") and reducing as far as possible the radiation in other directions (the "sky wave"). The range at which serious variations in the strength of reception occur after nightfall depends upon the interaction of these two

tubular feeder-line system to an aerial transformer house situated at the base of the mast, and thence to the mast aerial itself. The height of the mast is 500ft.

The Building

The plan of the building and the lay-out of the plant is similar to that of the Northern Ireland Regional Station. The building is of modern design, and is built

Westerglen. The method of synchronising the two transmitters is the same as that which is used at the London, West, and North National transmitters. The Burghead transmitter is driven by an electrically-maintained tuning fork, which, in turn, is controlled by the master tuning fork at Westerglen to which it is linked by land-line.

The Power Supply

This is taken from the mains of the Grampian Electricity Supply Co. through a sub-station on the site. The various supplies for the transmitter, including the 18,000-volt high-tension supply for the valve anodes, the low-tension supplies for heating the filaments, and the grid-bias voltages, are all obtained from motor-generator sets, and in all cases standby equipment is provided. An emergency power supply is available, in case of mains failure, from a Diesel-driven alternator set installed in the power house, while a storage battery provides emergency lighting and power to operate auxiliary plant. The water supply is taken from the joint mains of the County Councils of Moray and Nairn.

The front part of the building contains the offices, staff mess room, valve stores, a quality checking room, and the control

(Continued on page 184)

Modern Speaker Ideas

It is Not Always Advisable to Adhere to Theoretical Standards, and Some Suggestions for Improving Reproduction by Unusual Schemes are Given in This Article.
 By W. J. DELANEY

FOR a long time it has been laid down that the correct method of using a moving-coil loudspeaker is to mount it on a flat baffle at least three feet square. Theoretically this is perfectly sound, but to carry theory to its logical conclusion the amplifier with which the speaker is used must also be theoretically ideal, and the room in which reproduction takes place should also be acoustically perfect. In the ordinary home both these latter requirements are impossible to meet and thus the above-mentioned idea suffers a set-back. If we mounted a modern efficiently-designed moving-coil speaker on a five or six-foot baffle having a thickness of at least one inch, and stood this on a concert platform where sound-boards and other acoustic aids had been installed, and fed it from an instrument such as that installed at the Science Museum, we should approach the ideal. But in the average room there are carpets and curtains and chairs and tables, all of which act upon the sound which is emitted from the loudspeaker.

In the early days of broadcasting (and even to-day in some studios) the principle of draping the studio with heavy curtains

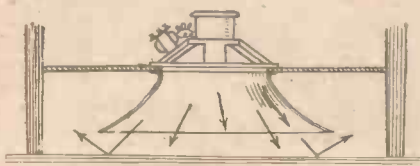

Fig. 2.—Directing the sound downwards often proves very satisfactory.

was adopted in order to prevent resonances, and the normal carpets and fabric furniture in a room will act in a similar manner. Furthermore, the ordinary type of receiver delivers an audio output which is far from straight.

Helping Sound Waves

This may sound as though the advice which has been given for years to the ordinary listener has been all wrong, but it is well to remember that one always aims at an ideal, and it is in the interest of everyone to endeavour to attain that ideal. But we cannot expect the ordinary listener to furnish a room (or perhaps one should say de-furnish it) in order to obtain perfect reproduction. Nor can we expect to take all the chairs, table, etc., outside the room when we listen in. But we can take other steps which will have the same ultimate effect, and experiments which have extended over many months show that some remarkable results are obtainable by very simple means. These various schemes are, however, entirely unorthodox, but the results obtained will well repay study, and without going to the expense or necessity of altering the amplifier you are now using you may be able to make a vast difference

to reproduction merely by altering the position of the loudspeaker, or the method of delivering to the surrounding air the impulses delivered by the speaker diaphragm.

It should be remembered that when the

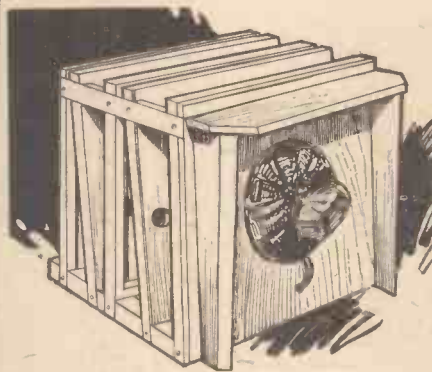

Fig. 1.—The Prism Loudspeaker which employs "tuned" baffles

loudspeaker is in operation the cone is being driven backwards and forwards, thereby setting into motion the surrounding air. In the ideal arrangement mentioned in the opening paragraphs the cone forms a piston which sets into motion the air in front of it and the waves of motion travel away towards the listener. The movement of the air at the rear of the baffle may be more or less ignored. But when we come

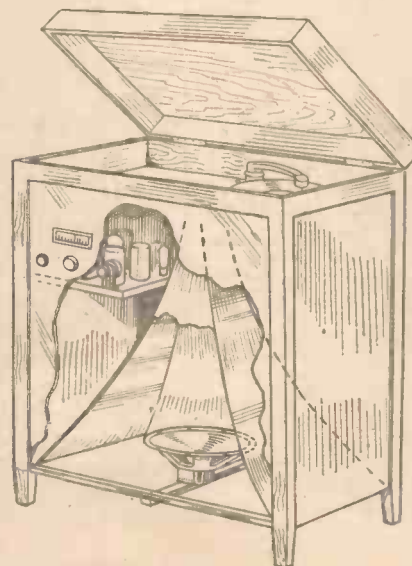

Fig. 3.—A novel method of incorporating a horn reflector in a radiogram cabinet.

to consider such instruments as the double string bass, the drum and percussive brass instruments, such as the trombone, there are one or two points which cannot be taken care of by this simple speaker mounting.

Resonances

The air inside the double bass and inside the bass drum will resonate, and the resonance gives a colouring to the tone which is difficult to reproduce in a simple cone speaker on a flat baffle (presuming, of course, that the amplifier is free from resonances). Similarly, the trombone notes are emitted as more or less blasts of air which must eddy round the bell-like mouth of the instrument. The resonances of the lower part of the trombone give rise in this case to the particular tone and distinguish it from the trumpet or saxophone. The non-musical listener cannot hope to introduce resonances of such a character that they will balance up the reproduction, but one

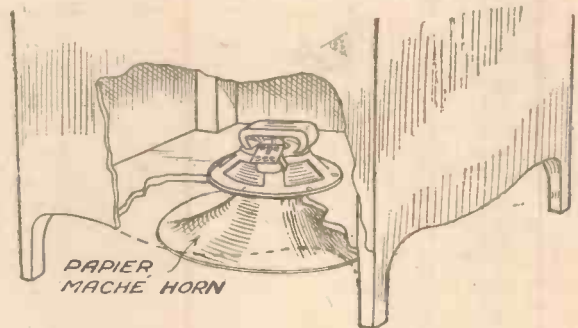
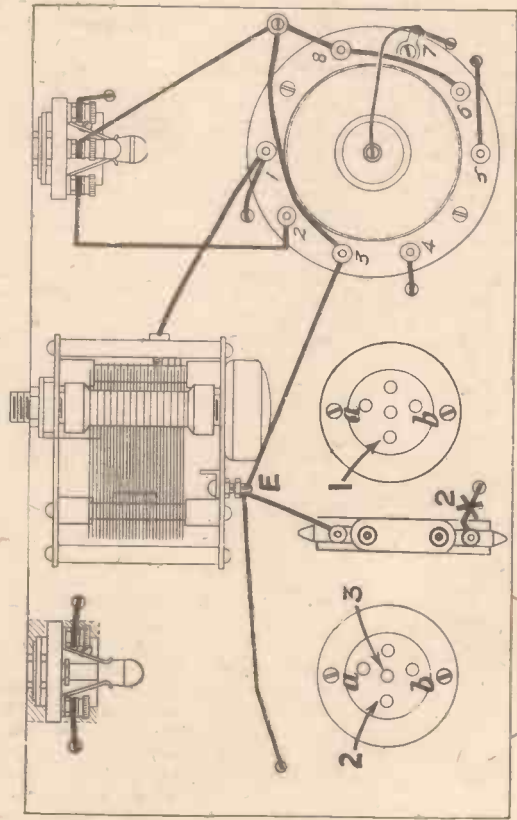

Fig. 4.—A deflector placed on the floor in conjunction with the idea illustrated in Fig. 2.

or two ideas on the following lines will perhaps result in an improved effect in the ordinary home. Before giving the few experiments which I have tried with success it might be mentioned here, in case anyone desires to criticise the statements already made, that the Prism Manufacturing Company have concluded experiments on similar lines, and, as a result, have introduced a speaker which is unorthodox, but which supplies a remarkable quality of reproduction, due entirely to artificial resonances. It should be heard by those who criticise the problem of resonances. The speaker is illustrated in Fig. 1, and it will be seen to be built up of baffles arranged at various angles. These baffles are all "tuned," the work being carried out by experts with sound musical knowledge. Two speakers are arranged on the baffles in different positions and, furthermore, the sound waves issuing from the cone are set into motion by means of "fins" arranged in front of each cone. Revolutionary, but remarkable in its effect.

(Continued on page 160)



Top of Chassis View

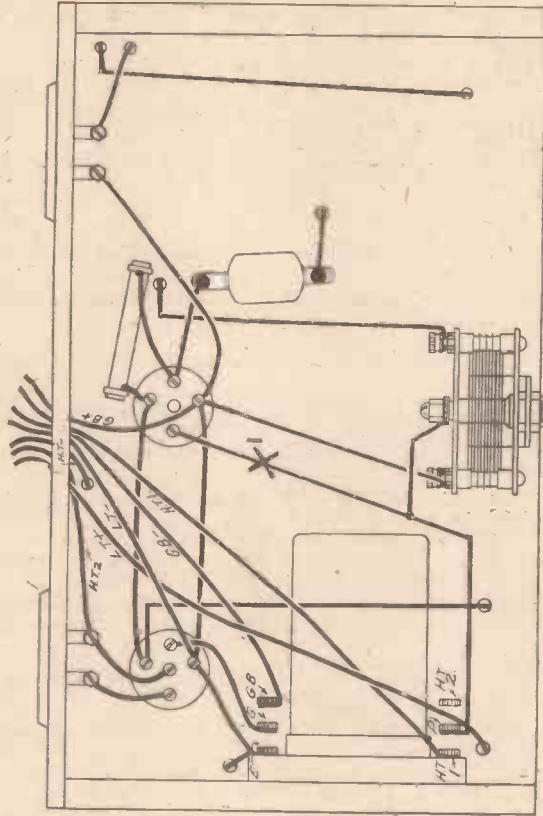

Underside of Chassis

Approximate Voltage Readings

- Voltmeter — to E
- ” + to 1 = 60 volts.
- ” + to 2 = 115 volts.
- ” + to 3 = 120 volts.
- ” to a and b = 2 volts.

Approximate Current Readings

- Milliammeter connected at XI = 1 1/4 mA.
- ” ” at X2 = 9 mA.

Approximate Resistance Readings

- | | | |
|------|-----------------|--------------------|
| Coil | Ohmmeter across | 1 and 3 = 26 ohms. |
| ” | ” | 1 and 2 = 5 ohms. |
| ” | ” | 3 and 4 = 5 ohms. |
| ” | ” | 7 and 8 = 13 ohms. |
| ” | ” | 5 and 7 = 3 ohms. |
- Transfeeda
Ohmmeter across P and HT1 = 50,000 ohms.
” ” G and GB = 2,500 ohms.

TO TRACK THAT FAULT—

READ

“EVERYMAN’S WIRELESS BOOK”

3/6, by post 3/10, from George Newnes, Ltd.,
8-11, Southampton Street, Strand, W.C.2.

Gramophone Pick-up Connections

Some Useful Suggestions Regarding Pick-up Connections for Various Types of Radio Receivers

By H. J. BARTON CHAPPLE, B.Sc., A.M.I.E.E.

THE usual method of connecting a gramophone pick-up to a receiver employing a triode or pentode detector valve is well known, and in the case of the simplest sets it is usually sufficient to shunt the pick-up across the grid leak, without the complication of switching, but it is generally considered good practice to disconnect the detector grid from the radio-frequency circuits in order to prevent break-through of radio programmes when records are being reproduced. The basic circuits of these conventional arrangements have been published in these pages from time to time.

Recent developments in receiver design have rendered it necessary to modify the pick-up arrangements in many circumstances, while the characteristics of the

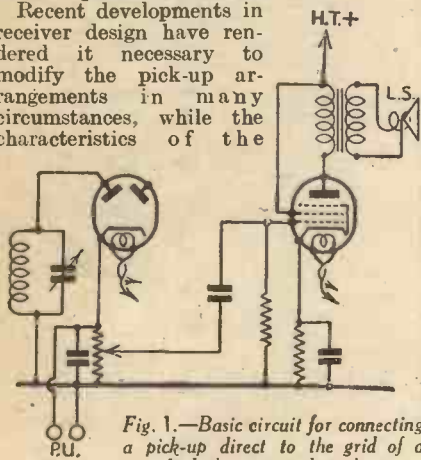

Fig. 1.—Basic circuit for connecting a pick-up direct to the grid of a high-slope pentode valve.

pick-up itself must also be taken into consideration when deciding the actual circuit to be employed. One of these developments is the steady increase in the sensitivity of the modern superhet receiver as a result of which it is found that, unless special precautions are taken, radio programmes are liable to impose themselves upon the gramophone reproduction, even although a switch is incorporated to isolate the grid of the valve to which the pick-up is connected from the radio-frequency portion of the receiver. This break-through is probably due to capacitive coupling and, in order to avoid this risk, it is good practice to omit the isolating switch, merely connecting the pick-up to the control grid of the appropriate valve, and silencing the radio-frequency and intermediate frequency section by disconnecting the aerial, short-circuiting the control grid of the frequency-changer, and disconnecting its anode. These operations call, of course, for fairly complex switching, but the multiple radio-frequency switch units now available can be readily pressed into service, and the necessary connections furnish an interesting problem for the amateur.

With Output Pentodes

Another development which has had

considerable effect upon pick-up practice is the introduction of the high-sensitivity output pentode, which in many cases (particularly in the battery types) give their normal output for a grid input which can be supplied direct from the pick-up. There are instances, therefore, where the pick-up may be switched direct to the output valve, but this connection should be taken to the volume control if this component directly precedes the output valve as it does in most superhets employing a diode detector. Fig. 1 shows this arrangement.

The more general use of a diode detector presents further problems in connection with the feeding of the pick-up output into the receiver circuit, as it sometimes happens that the pick-up voltage available is not sufficient fully to load the output valve. Where there is a first stage of low-frequency amplification between the diode and the output stage, the solution is quite simple—the pick-up may be connected to the grid circuit of the first low-frequency amplifier with a simple change-over switch to insert the pick-up, and disconnect the detector output as indicated in Fig. 2. No change in grid-bias arrangements will be necessary in this case.

The arrangement shown is for use where a separate volume control for the pick-up is fitted, as is often the case, the volume control being incorporated in the base of the tone arm, or supplied as a separate unit. In receivers where the manual volume control for radio is included in the diode detector circuit, it may be desirable to use this to control the pick-up also, in which case the pick-up must be switched across this control, and steps similar to those already described taken to prevent radio break-through.

Special Cases

In many cases, a double-diode-triode valve is used in place of a separate diode and low-frequency amplifier, and in such instances the pick-up can again be connected across the grid circuit of the triode portion of the combination valve. The actual arrangement will depend, to some extent, on the design of the low-frequency section of the receiver. If the volume control of the receiver is connected between the diode detector portion and the triode amplifying portion of the double-diode-triode valve, it may be employed as gramophone volume control, or switching may be so designed that a separate volume control for the pick-up is used. In some circuits, however, the volume control of the receiver is placed between the triode amplifier and the output stage. While in this position it certainly controls the volume on gramophone, but it may fail to fulfil the other function of a volume

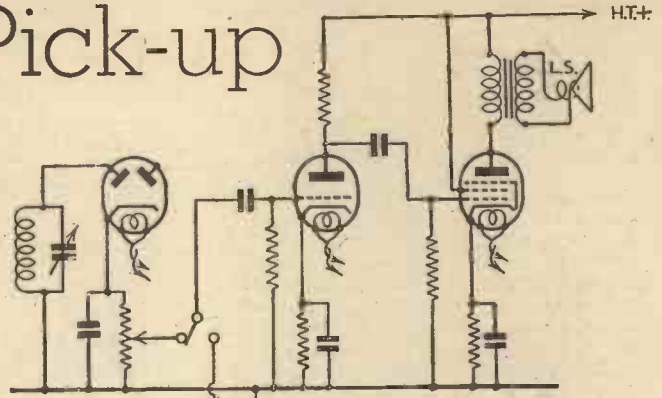

Fig. 2.—A pick-up with separate volume control, connected to first L.F. amplifier.

control, namely, to avoid overloading. If the pick-up is connected directly to the grid of the triode section of the double-diode-triode, it is possible that with a sensitive pick-up, or on certain classes of record, the pick-up voltage will be too large to be handled without introducing distortion by the triode. It may be advisable, in such circumstances, to fit a separate volume control directly across the pick-up itself.

Ganging Volume Controls

There are two other cases in which the inclusion of a separate pick-up control may be necessary. The first is where the only manual volume control for radio is a potentiometer or variable resistance controlling the grid bias to variable-mu H.F. or I.F. valves. This practice is found usually in straight T.R.F. sets employing an amplifying detector. In order to avoid the complication of two volume controls on the panel, the gramophone volume con-

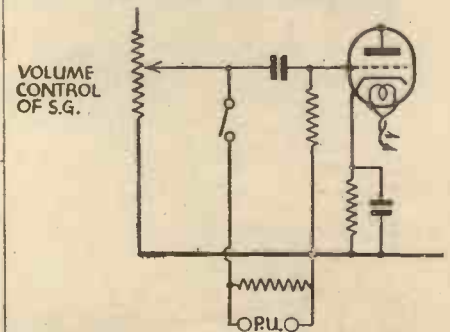

Fig. 3.—Method of avoiding two volume controls when a low-resistance volume control is required for a pick-up. The pick-up is shunted by a resistance to reduce effective load into which the pick-up feeds.

trol may conveniently be ganged with the radio volume control, unless it is incorporated with the gramophone tone-arm or mounted on the motor board.

The other case where separate gramophone and radio volume control may be required is when the pick-up manufacturer recommends a total resistance for the volume control which is much smaller than that used for the normal radio volume control. In some cases, however, this difficulty may be overcome by shunting the pick-up by a resistance equal to that recommended for the volume control, and connecting the whole in parallel with the radio low-frequency volume control as suggested in Fig. 3.

(Continued overleaf)

GRAMOPHONE PICK-UP CONNECTIONS (Continued from previous page)

A Modern Method

Possibly the most interesting of the problems connected with gramophone pick-up switching is that which arises when the diode is followed immediately by the output valve and yet an additional stage of low-frequency amplification is required for gramophone reproduction. In a number of cases the intermediate-frequency amplifying valve can be pressed into service, the pick-up voltage being applied to its grid, and the connections of the valve altered by suitable switching to permit the valve to act as a low-frequency pentode amplifier, resistance-capacity coupled to the output valve.

A very ingenious adaptation of the idea has been used in some of this season's commercial models. It consists of using the intermediate-frequency valve, which is a variable- μ screened pentode, for amplifying the pick-up voltage, but the pentode characteristic of the valve is not employed. Instead, the valve is made to function as a triode amplifier, its auxiliary grid or screen being used as the anode, and the radio-frequency and intermediate-frequency signal circuits being rendered inoperative by disconnecting the aerial and frequency-changer anode, shorting the frequency-changer control grid, and increasing the negative bias to the frequency changer.

The basic circuit for this arrangement, in so far as the intermediate-frequency valve connections are concerned, is indicated in Fig. 4. It will be observed that the essential switching is comparatively simple, and consists of one single-pole switch and one single-pole two-way switch, which may, and should, be ganged together. Switch A, in the "radio" position, short-circuits the gramophone pick-up, but when moved to the "gramo" position removes the short circuit, leaving the pick-up connected between the I.F. valve grid and the earth line on the earth side of the A.V.C. by-pass condenser. It is now

is moved to the "gramo" position, R_1 and C_2 are disconnected from the auxiliary grid, but R_2 remains in circuit and functions as the anode load of a triode; that is to say, the low-frequency amplifying valve consists of the cathode of the I.F. valve, its control grid, and its auxiliary grid acting as anode. A connection from the auxiliary grid via the condenser C_3 transfers the audio-frequency voltage developed across R_2 to the normal low-frequency volume control of the receiver, and from the slider of this component the signal is applied to the control grid of the output valve.

necessary to note the action of Switch B. When this is in the "radio" position, the auxiliary grid of the I.F. valve is connected to the H.T. positive line via two resistances in parallel, R_1 and R_2 , of which R_1 is comparatively small, and is the normal value for providing the correct screen voltage when the valve is used as the intermediate-frequency amplifier and is by-passed to earth via the condenser C_2 , while R_2 is a high resistance of about 100,000 ohms. When switch B

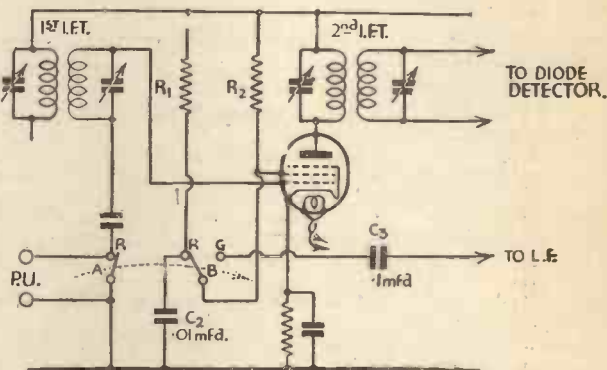

Fig. 4.—Method of using I.F. pentode as L.F. triode amplifier for gramophone reproduction.

MODERN SPEAKER IDEAS

(Continued from page 157)

Speaker Position

Instead of arranging the speaker facing outwards in a standard gramophone type of cabinet, the experiment of mounting

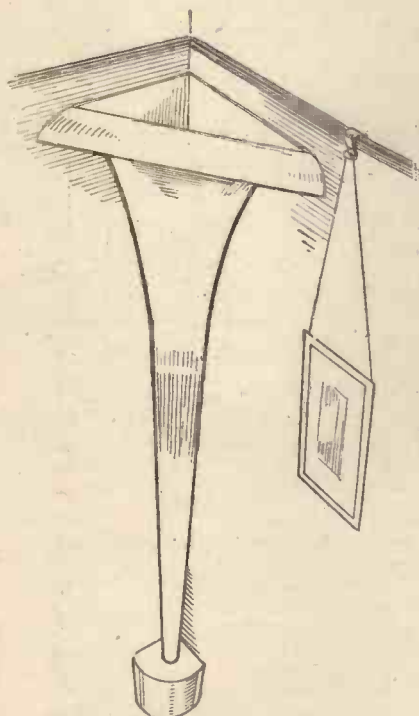

Fig. 5.—Although not elegant, this type of horn speaker gives remarkable results.

it facing downwards about eight inches from the floor should be tried. The cabinet must, of course, be raised on legs, and the floor beneath the speaker should be devoid of carpet or lino (Fig. 2.) With one particu-

lar circuit this gave uncanny depth of tone, but was useless from a musical point of view owing to the high-note cut-off. This was remedied to a certain extent by placing on the floor an inverted cone made from papier mâché. The cone was approximately twice the diameter of the speaker cone (Fig. 4). Unfortunately, this particular scheme appeared only to function satisfactorily when the cabinet was placed in the centre of the room, and if stood near a wall in the customary position was not at all good.

An improvement on the idea, and one which was so satisfactory that it was left as permanent in one receiver built for a friend, was with the speaker in the same position, but reversed. The receiver chassis was attached to the motor-board in the cabinet, and the mains unit was placed well over on one side of a shelf which had been erected in the cabinet. From the centre of the motor-board down to the bottom of the cabinet "floor," thin sheets of mill-board were attached to form an inverted horn. The sound was thus directed upwards and then downwards from the motor-board, issuing to the floor round the speaker, which was held in position by short iron brackets attached to the front and rear of the cabinet. (See Fig. 3.)

As a further step in the development of particular resonances, the speaker may be mounted in the customary position, but the bottom or floor of the cabinet may be cut out in slots, each slot being divided up by a short vertical strip, as shown in Fig. 6. Some experiment is here necessary to decide upon the number of openings in the floor,

and the various heights of the strips. They may, for instance, be arranged in gradually increasing steps, or with one up and the next down, and so on.

A development which is not too happy in the ordinary home is to build a large exponential horn from plywood, to stand in a corner, and fit at the base of the horn, a very small moving-coil speaker. One of the "midgets" will do, or a special speaker made for use with a horn (Fig. 5). Various schemes for producing the effect of an elongated horn were tried out, but in many cases did not give the desired effect. It should be emphasised, however, that the ultimate result will depend both

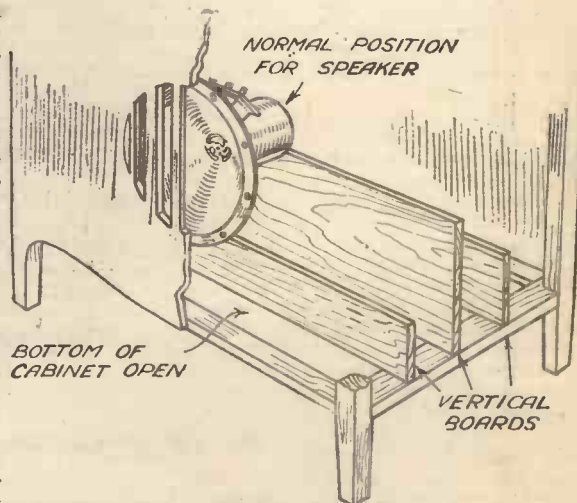

Fig. 6.—A splendid scheme for improving quality with ordinary apparatus.

on the amplifier characteristics and on the shape of the room and its furnishings. Experiments must therefore be carried out by each individual for his particular combination.

WHICH L.T. BATTERY ?

How to choose the correct type

Low tension batteries may be broadly divided into two types ; those containing two or three thick plates represented by the Exide 'D' Series, and those having the multi-plate assembly, typified by the Exide 'Hycap' Series. Each is designed for certain operating conditions and if used under any other conditions the results will not be satisfactory.

The Exide 'D' Type Battery is designed for slow discharge and infrequent recharging. It is therefore only suitable for small sets, but with such sets it is possible, by using a battery of sufficient capacity, to make recharging very infrequent indeed. Under these conditions its life will be very long.

If, however, it is used with a set that demands so much current that recharging is more frequent than once a fortnight, then it will not give its full rated capacity and its life will be impaired.

Over 90% of present-day sets consume an L.T. current greater than 0.4 amperes or more. This is because



they use more valves and dial illumination has become general. Thick plate batteries are not suitable for these sets and the Exide 'Hycap' Battery should be used. With these modern big sets the Exide 'Hycap' Battery will give from 35% to 90% more listening hours per charge and will have greater durability. It has the additional advantage that it can be recharged quicker.

Both the Exide 'D' type and the Exide 'Hycap' Battery are fitted with the Exide Indicator, which tells you in time when to recharge.

Sizes and Prices of Exide 'Hycap' Batteries

Type	Voltage	Capacity in ampere hours at the 20 hr. rate	Price (uncharged)
OCG3-C	2	15	8/6
GFG4-C	2	24	10/6
GKG5-C	2	36	12/6
CZG6-C	2	60	15/6

Obtainable from all reputable dealers or Exide Service Stations.

EXIDE BATTERIES • EXIDE WORKS • CLIFTON JUNCTION • NEAR MANCHESTER • ALSO AT
LONDON • MANCHESTER • BIRMINGHAM • BRISTOL • GLASGOW • DUBLIN AND BELFAST

TELEVISION DEVELOPMENTS

A NEW LARGE DIAMETER TUBE FOR TELEVISION REPRODUCTION

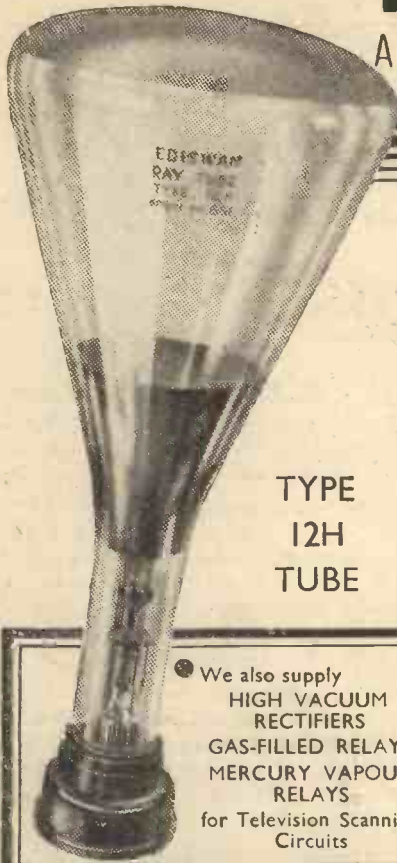

TYPE
12H
TUBE

The Ediswan Type 12H tube has a screen diameter of 12" giving a television picture 10" x 7½" without distortion.

The screen is of special material giving a close approximation to a black-and-white picture.

Specification :

Indirectly heated high vacuum tube. 2nd Anode Volts - - 1200
Heater Volts - - - - 2.0 1st Anode Volts - 150-400
3rd Anode Volts (Max.) - 6000 Sensitivity(mm.per volt) 950/V*

*V=final anode volts

List Price £15. 15. 0

ENTIRELY BRITISH MADE

EDISWAN RADIO VALVES

THE EDISON SWAN ELECTRIC CO. LTD. 155 CHARING CROSS RD., LONDON, W.C.2

R.E.299

We also supply
HIGH VACUUM
RECTIFIERS
GAS-FILLED RELAYS
MERCURY VAPOUR
RELAYS
for Television Scanning
Circuits

USED BY ALL GOVERNMENT DEPARTMENTS

Do you smoke a DE LUXE TOBACCO ?



Airman Navy Cut De Luxe appeals to the particular smoker who wants a luxury tobacco at a moderate price. Essentially a Navy Cut it is ready for the pipe and requires no 'rubbing.'



PLAYER'S

AIRMAN NAVY CUT DE LUXE



P.A. 49, B AIRMAN MIXTURE, FLAKE & NAVY CUT ARE 10d. AN OZ.

To maintain Good Reception

To trace faults it is essential to have an accurate meter. The AvoMinor enables you to service your set efficiently and speedily. With either of these accurate combination meters you can track down trouble quickly and make every test to valves, circuits, components, batteries and power units. Each model of the AvoMinor covers a wide field of measurement and provides testing facilities unrivalled by any other meters near their prices.

The Universal AVOMINOR

A smaller brother of the Universal Avometer. Gives 22 ranges of readings. (A.C. and D.C.) in current, voltage and resistance. 5in. scale. Total resistance 200,000 ohms. Complete with instruction book, leads, interchangeable testing prods and crocodile clips. Price £5



The D.C. AvoMinor
Current
0-6 m/amps.
0-30 ..
0-120 ..
Voltage
0-6 volts 0-240 volts
0-12 volts 0-300 volts
0-120 volts 0-600 volts
Resistance
0-10,000 ohms
0-50,000 ..
0-1,200,000 ..
0-3 megohms

Price
40/-

Deferred Terms if desired.
Descriptive pamphlets
post free from:
THE AUTOMATIC COIL
WINDER & ELECTRICAL
EQUIPMENT CO., LTD.,
Winder House, Douglas St.
London, S.W.1.
Telephone: Victoria 3404/7.

The AVOMINOR

BRITISH MADE

Regd. Trade Mark

Obtainable at all good Radio Shops



On Your Wavelength

By THERMION

Entering the Radio Profession

SUCH is the belief in my knowledge that I am often consulted by young men and their parents as to the best method of entering the radio trade. There are those who think that this young industry can absorb all of the brainy youths who are being turned out (I use the phrase in its best sense!) by our schools and colleges.

I am expected to adumbrate a course of study for them so that afterwards all obstacles are cleared away and the road is clear for fortune—free from the hard knocks of adversity. No more to-day than at any other time is there a royal road to success in this profession; in fact, the difficulties are greater because the standard of intelligence and the knowledge level have risen considerably since I parted company with my *alma mater*. No more do we boggle at the *pons asinorum*, and the secondary schoolboy of to-day is equal in intelligence to the man of twenty-one of a few years ago, but as this is general we are no better off. It would seem that, shortly, extreme qualifications will be necessary in order to obtain a job as a newsboy. What was considered above the average of intelligence a few years ago is now considered very ordinary, and you have to have an almost superhuman mental superiority in order to stand above your neighbour. The radio industry is peopled by those who have first-class qualifications. It has no room for the mediocre nor for the man who merely wishes to earn a weekly wage. Fortunately, there are excellent correspondence courses available for those who have allowed their education to lapse. To enter the radio trade with the idea of advancement you require to have an excellent theoretical knowledge of electricity and radio. But knowledge alone is insufficient;

you need the driving force and a dynamic outlook to break down the barriers. A little influence goes a long way in gaining an introduction, but it will not help you to hold your job if you are incapable or lazy. Nothing can prevent a man whose heart is in radio from making good in it. Advice to such an individual is useless. He will carve out his own career in spite of objections and, maybe, negative advice. There is no regular formula which, if followed, leads to success. The will to get on is like the will to live; without it you fade and die.

Where Do I Live?

ONE of my readers who imagines he is a Sherlock Holmes has been trying to locate my demesne from the fact that I have sometimes stated how far I reside from Daventry and other stations. He writes: "Long before Thermion was amusing himself by describing weekly his success in destroying H.T. batteries by continuance discharge, Daventry was being built. I remember, when you were attempting to estimate its probable field-strength, you wrote that your domicile was situated thirty miles north of 2LO, and (I believe) forty miles from Daventry. Then, as now, your chief obsession in life appeared to be the preservation of your incognito, so, in the best Sherlock tradition, I endeavoured to triangulate your home. I think I placed you, to my satisfaction, in either Dunstable, Luton, or Welwyn Garden City, so you will note, from the enclosed cutting that my mensuration was deplorably bad. But my failure does not lessen my gratitude to you for your years of consistent and entertaining journalism, in which you have persisted, in spite of the vicissitudes of a changing and depreciating cult."

I can only say that this reader is all wrong. I do not live in any of

these districts and I have never done so. My domicile, like my identity, must remain a mystery forever. Incidentally, why is it that so many readers seem interested in who I am, what I am, and where I live? Is some sinister motive behind it? Do they hope to track me down and brain me with a pole-axe? Truly, you must judge a man by his work. The individual does not matter. You may admire the work but not the man. You may admire the man but consider him incapable of coherent thought. I am what I am and who I am. If I sign myself as George J. Thermion you would not be any the wiser and would probably consider that that was my real name. As you do not know me, Thermion is as good as my real name. If I gave you the latter you still would not know me. What's in a name? Shakespeare supplies the reply by asserting that the rose by any other name doth smell as sweet!

Baseboards Again

THOSE readers who insist that baseboards provide the best system of construction will ascend to Olympian heights of delight next week when we present a blueprint of Mr. F. J. Camm's "Record All-Wave Three," for this has been designed on a baseboard. I have been privileged to hear it, and must say that it gives me cause to ponder. Its range is wonderful, and its quality without peer. I do not know whether to ascribe this to the baseboard, however. One reader (E. W. B., of Herne Hill), writes:—

"I have read, with some amusement, your notes on the 'baseboard' controversy, and would like to tender my point of view on this subject.

"Chassis construction I would regard as being used by those who do not wish to dismantle the receiver once it has been fitted into its cabinet, and has the added advantage of more careful lay-out and design.

"The baseboard method, on the

other hand, enables the constructor to alter the design, which does not help the final result, which may be quite unsatisfactory.

"The usual outcome of this is for the constructor to say that So-and-So is a rotten designer, whereas the real fault lies in his own hands, by thinking that *he* knows better than the designer and the organisation behind him.

"If he only gave a little thought to the vast amount of work entailed to produce a set for him to construct, he would realise the folly of attempting to do something better. I agree that the majority of sets to-day call for chassis construction, and I have built several on these lines with good results, and I think that the baseboard set will gradually be left behind.

"I hope I am not boring you with this epistle, but I very seldom write letters of any description, and so if you think that any of the foregoing is worth a few lines in your weekly periodical, you are quite at liberty to use same."

Another reader (S. T. P., of Bethnal Green) says:—

"As an old constructor—from the days of boxed panels with crystal detector, the sloping panel valve sets, to say nothing of the baseboard-mounted 12in. solenoid coils, with 'tap' tuning—I am interested but not prejudiced in the controversy, chassis *v.* baseboard.

"It seems to me that one point is overlooked in the arguments for and against. That is, a real experimenter wants his base in such a form that he can change or add any component with ease; which procedure may also necessitate moving other parts slightly to make room. And a wooden baseboard enables this to be done by simply making fresh screw-holes. And when the board is too perforated to look respectable—as has often been the case with me—the board can be easily and cheaply replaced.

I have never used the metal chassis, but it appears to me that to make any change fresh holes must be drilled—a lot of trouble. And then a new base is comparatively expensive.

"On the other hand, when a set is being built for permanent use, when it is not likely any alterations will be made for at least a considerable time, I think the chassis an excellent idea; the extra space for fixing enables the set to be made more compact, the absence of many leads gives a cleaner appearance to the visible part, and rigidity is obtained. I have long used a box



Notes from the Best Bench

Fault Tracing in Superhets

MODERN superhets are more complicated than the straight type of receiver and are therefore more likely to give trouble. If an oscillator is available, however, faults in a superhet can generally be located quite as easily as in a straight set. Provided that the oscillator is capable of tuning to the intermediate frequency used in the I.F. stages of the receiver the first procedure is to connect the output leads of the oscillator to grid of the F.C. valve and earth respectively. The oscillator control should then be set for the frequency to which the I.F. transformers are to be tuned (generally 110 kc. or 465 kc.), and when the oscillator is switched on a note should be heard in the speaker if the I.F. and L.F. amplifiers are in order. If nothing is heard the oscillator can be fed into the grid circuit of the I.F. valve, and if the note is then heard it will indicate that the fault lies in the first I.F. transformer or in the F.C. valve circuits. If the note is heard when the oscillator leads are joined to the grid circuit of the F.C. valve, however, lack of signals will be due to a defect in the H.F. circuits—possibly a broken coil winding or a faulty wave-change switch.

Trimming in A.V.C. Sets

AFTER the fault has been located the I.F. transformer trimmers can be accurately adjusted by means of the oscillator, connection being made to the grid circuit of the F.C. valve. An output meter can be used for this adjustment or the ear can be relied upon to decide the exact trimming point at which the volume from the speaker is at maximum. When the receiver is fitted with A.V.C. the exact trimming point cannot be found unless the A.V.C. circuit is broken whilst the test is being made. If the A.V.C. circuit is complete the volume from the speaker will remain constant for widely varying inputs, and the correct setting of the I.F. trimmers cannot accurately be found. The best position to break the A.V.C. circuit is at the diode of the double-diode or double-diode-triode valve.

LATHE WORK for AMATEURS

1/-, by post 1/2, from.

GEORGE NEWNES, LTD.,

8-11, Southampton Street, Strand, London, W.C.2.

form base (wooden) for experimental sets, and found it much more convenient than a "baseboard" lay-out.

I can quite understand the feeling of those who already have a good cabinet and wish to modernise the receiver, yet find the specified metal chassis will not fit in. Would it not be possible to publish an alternative lay-out for the benefit of these? Of course, most constructors who have had any experience are able to arrange it themselves from the theoretical circuit, but there are many who do not feel competent to do so.

"I should like to express my thanks to you for the invariably interesting 'On Your Wavelength,' to which I always turn first on receiving PRACTICAL AND AMATEUR WIRELESS.

This reader is barking up the wrong tree. We use *metallised* wooden chassis, not *metal* chassis.

Now, Then, You Hams!

A FEW weeks ago I put readers in touch with Mr. T. E. Low, of 28, Allenby Road, Cadishead, Manchester, who had a pile of issues which he generously gave to the first applicant. He asked to be put into touch with some G ham in his locality, but apparently no one has reciprocated his kindness. He writes me as follows:—

"I want to thank you very much indeed for your kindness in telling the PRACTICAL AND AMATEUR WIRELESS readers of my offer. You will be interested to know that I had applications from all parts of the country. I have answered all applications. The R.A.F. men at Cranwell are taking the books off my hands. I know they (the books) will be fully appreciated. I mailed my copy of PRACTICAL AND AMATEUR WIRELESS to the U.S.A. (I send it every week to my pal out there, and if I neglect to miss once, then I get it in the neck. He says it is the *best* radio journal he has ever read; I fully endorse his words) Then the applications came in, from youngsters of fourteen to veterans of seventy-four. To be perfectly candid I thought that the construction side of radio had gone to the dogs, but now I know different.

"I am sorry to say that since you so kindly told the readers of my offer and appealed to some G ham around my locality to get in touch with me, I have had not one line of inquiry from any ham. I wrote to three in Urmston some weeks back, and enclosed postage for replies. I have heard nothing from them. I hate to think that British hams are so unobliging.

Practical Television

October 24th, 1936. Vol. 3. No. 21.

A GERMAN TELEVISION CAMERA

BOTH for the televising of the Olympic Games, and also during the Berlin Radio Exhibition, a direct pick-up electron camera was used with marked success. Based on the original researches of Farnsworth and built for the German Post Office by Fernseh A.G., the camera in question is illustrated in Fig. 2. The complete unit is very similar in external appearance to a film camera, being built up on a light tripod stand so that the camera can be panned very readily in any desired direction. This is effected in a horizontal direction by the straight handle shown at the back, while movement in a vertical plane is carried out by rotating the handle on the left, a reduction gearing giving a smooth, steady motion.

In the front of the camera case is a telescopic lens system of such dimensions and design that in the case of the Olympic Games, events taking place on the opposite side of the Stadium could be transmitted with sufficient detail for items to be recognised. The television section of the camera consists primarily of an evacuated cylindrical glass container (see Fig. 1), which has incorporated at one end a photo-electric cathode. The preparation of this photo-electric layer is of such a character that it is capable of emitting electrons from its surface in direct proportion to the intensity of light to which it is subjected.

Optical Image

In use, therefore, the lens, of large aperture, forms an optical image of the scene to be transmitted on the flat surface of the prepared cathode. From every point of the surface electrons are liberated, corresponding in density to the brightness of each point of the optical image. Thus, an invisible electron beam is emitted from the cathode, the application of a positive potential at the far end of the tube ensuring that the electrons proceed forward at high speeds.

To produce an undistorted electron picture, however, an external solenoid coil surrounds the glass cylinder. By a suitable adjustment of the strength of the direct current passed through this coil it is possible to make the resultant magnetic field act as a magnetic lens, and produce in what is known as the target plane an electron picture which is an exact replica of that originally produced at the cathode surface. This coil is shown diagrammatically in Fig. 1.

In the target plane of the electron picture is a small square scanning aperture,

the size of which corresponds exactly to one picture element. That is to say, if the picture size produced in the camera is 4ins. by 4ins. and the degree of definition one of 240 lines, then the aperture would be 1/60th of an inch square.

Scanning

As readers know, scanning is really a case of relative motion whereby every element of the picture is explored in turn so as to produce an equivalent electrical signal. With this electron camera the aperture is fixed in position, and the electron picture is made to move in two directions, that is horizontally (line scan) and vertically (frame scan). This is brought about by passing currents of a special shape through two pairs of coils mounted at right angles to one another external to the tube. The resultant dual magnetic fields impose

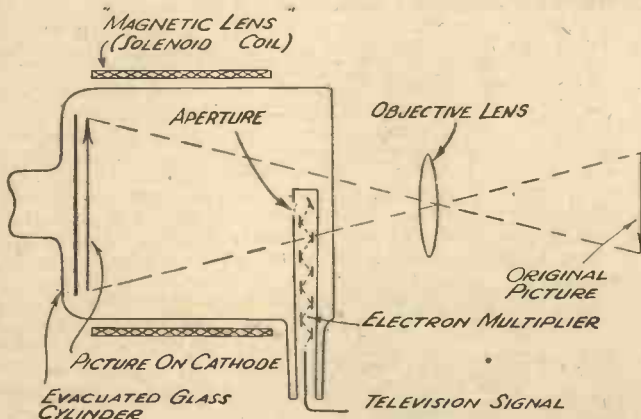

Fig. 1.—A simple diagrammatic representation of the German electron television camera.

a movement on the beam so that every point of the electron picture is passed over the fixed aperture in closely adjoining lines.

Electron Density

The density of the electrons passing into the aperture at every instant corresponds exactly to the brightness of the picture element to be transmitted at that moment. These electron currents, which are extremely minute, are amplified within the aperture tube by means of secondary emission. For this purpose the electrons are directed along a special path, so that they are caused to strike a series of electrodes, the surfaces of which have been treated in a certain way. The impact of every electron hitting a surface of this kind knocks away several so-called secondary

electrons, and these in turn add to the original electron stream, causing a marked amplification of the original aperture current. The dissected picture current produced in this manner is further amplified in a normal thermionic valve amplifier before being made finally to modulate the ultra-short-wave carrier of the television broadcasting station.

Flicker Eliminated

The pictures produced by this electron camera were shown to an interested public on cathode-ray tube television receivers at the Berlin Radio Exhibition, and the results were stated to be quite satisfactory, whether fed by line or radio to the sets in question. In addition to pictures produced by this camera by consecutive sequential scanning, another electron camera of the same type was on view. This produced a picture having a definition of 375 lines, but in this case the scanning was interlaced. First the odd lines and then the even lines were traced over the fixed aperture, giving

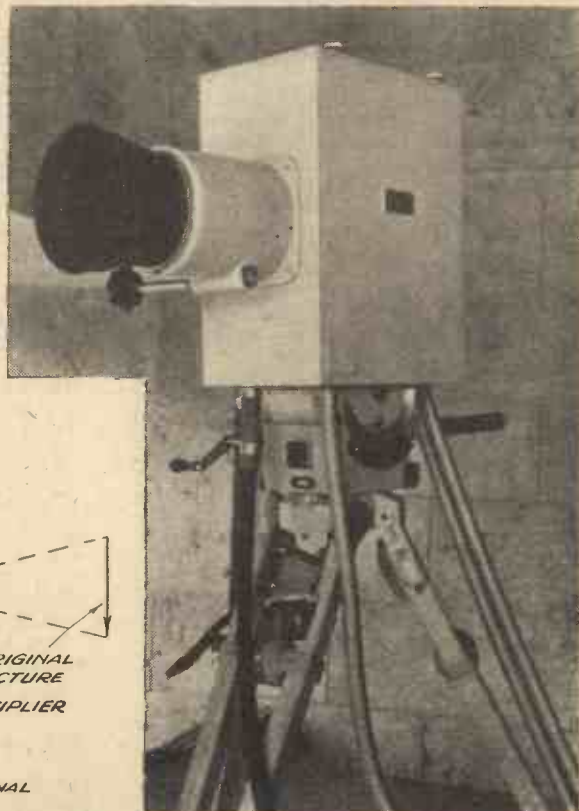

Fig. 2.—The direct pick-up electron camera which in operation resembles that of a cinema camera.

a total of 50 frames of 187½ lines per second interlaced, so that there was a total of 25 complete pictures in one second, each of which had a total definition of 375 lines. In this way flicker was reduced to a negligible quantity, a fact borne out by observation on the receivers operating in conjunction with this second electron camera.

FREE NEXT WEEK!
BLUEPRINT OF
F. J. CAMM'S
"RECORD ALL-WAVE
THREE"

TELEVISION NOTES

Television at the Science Museum

TELEVISION demonstrations are being given every day at the Science Museum from 11-12, and from 3-4 p.m. until further notice.

It is estimated that more than 2,000 saw the demonstrations in the first two days.

The demonstrations are given on a Cossor receiver, which has been fitted up in a special hall in the basement of the Museum, and visitors can watch the reception for at least five minutes—longer when not crowded.

The top right-hand illustration on this page shows the special aerial which has been erected on the roof of the Museum for reception of the Alexandra Palace transmissions.

A Surgeon's Forecast

Six or seven years ago when transmissions of low-definition television had begun, *Punch* published a cartoon showing a doctor in his surgery. Above his desk was the head of a child seen on a large television screen with the tongue out for the doctor's inspection. The caption, in a humorous vein, mentioned that the diagnosis of certain complaints would be undertaken by doctors without patient or doctor moving from their respective homes. Now we have Sir Crisp English at the opening of the autumn session at the Medical School of St. George's Hospital voicing an opinion that television of the future would undoubtedly be of great use to the medical profession. He visualised as a certainty the *Punch* cartoon drawn in such a light vein, together with other scientific developments which would bring about an entirely new basis of relationship between the doctor and his distant patient.

An Innovation

According to details furnished of the experimental television programmes, a special feature will be introduced which is an innovation as far as the motor-car

trade is concerned. Twenty cars of British make are to be driven in turn before the television camera, and will be described by a commentator. Hitherto the motor-car manufacturers have kept details of their cars shrouded in mystery until the Motor Show opened at Olympia, but this year the Society of Motor Manufacturers and Traders have extended a very welcome hand to a younger science by selecting twenty of the principal British cars for simultaneous exhibition through the medium of television. This form of programme, although freely talked about several months ago, was not expected after the Government had decided during the B.B.C. charter renewal discussions that direct advertisements or sponsored programmes were to be excluded from the television transmissions. Without any form of blatant advertising, which people in this country abhor, it should be possible to display equipment or machines which have some topical news value at the moment. The announcer could then describe in fair detail whatever event has happened and state that the equipment used for the purpose and then being shown on the television receiver screens was manufactured by — Company. Under these conditions the whole programme could be paid for by the company concerned and under a scheme of this simple nature there seems little doubt that ample support would be forthcoming from firms who believe in modern methods of advertising. Incidentally, it is interesting to recall that in

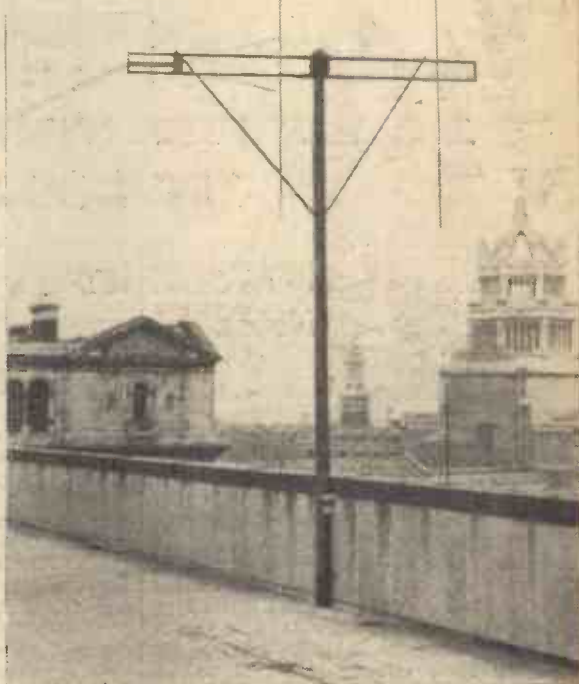

The special aerial on the roof of the Science Museum for the reception of the television transmissions from the Alexandra Palace.

September, 1932, both Jim Mollison and Amy Johnson, after one of their spectacular flying feats, were seen and heard on one of the B.B.C.'s low-definition television transmissions. Fresh from any national triumph it is only natural that an individual or individuals would make a greater appeal to the public if there was a "two dimensional" radio broadcast—an appeal to sight and hearing. The television director should find little difficulty in making his programmes of sustained interest with broadcasts of this character, and if permission is given it is certain that he will keep a very watchful look-out for events which can be portrayed in this way by the scanners at his disposal. It is fortunate that the Alexandra Palace building itself is built in such a way that the television cameras can be employed in such a manner as this.

Regular Programmes

The B.B.C. regular television service will begin on November 2nd. It will be opened by the Postmaster-General and Mr. R. C. Norman, the Chairman of the B.B.C., and Lord Selsdon, Chairman of the Television Advisory Committee, will also take part in the ceremony at Alexandra Palace, which will be televised.

Regular programmes will thereafter be given twice a day, from 3.0 to 4.0 p.m. and from 9.0 to 10.0 p.m. except on Sundays.

The choice of transmitting system to be used at the opening has been decided by the toss of a coin and has been won by Bairds.

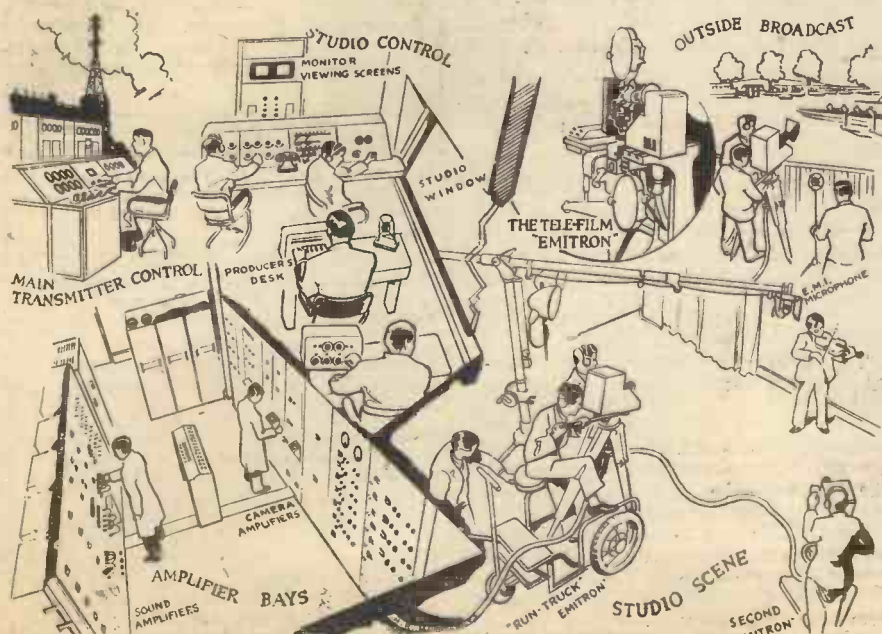

Diagram showing the sequence of operations for televising with an "Emiltron" camera.

**THE WIRELESS CONSTRUCTOR'S
ENCYCLOPÆDIA**

By F. J. CAMM
(Editor of "Practical and Amateur Wireless")

4th Edition **5/-** net

Wireless Construction. Terms and Definitions explained and illustrated in concise, clear language.

From all Booksellers, or by post 5/6 from George Newnes, Ltd., 8-11, Southampton Street, Strand, London, W.C.2.

Free Sets of Gold-Coloured Initials FOR YOUR CAR DOORS



EVERY motorist who takes a pride in his car will be delighted with this splendid Free Offer. PRACTICAL MOTORIST, the really helpful Motoring Weekly, offers to send you two sets of initials for transferring to your car doors, and these are quite FREE if you will fill up the coupon in to-day's number with the initials required and enclose a 1½d. stamp for return postage.

The initials are in gold tone and very pleasing in appearance and will give your car or its equipment—touring bags, maps, etc.—that individuality which every motorist desires.

Get to-day's PRACTICAL MOTORIST—it is the greatly enlarged Motor Show Number—and send up for your initials. They will be sent to you by return.

See this week's

Practical Motorist 3^d

★ BIG MOTOR SHOW NUMBER

At all Newsagents and Bookstalls, or by post 4d. from the Publisher, 8-11, Southampton St., Strand, London, W.C.2.

George Newnes Ltd.

● THE MOST SUCCESSFUL ELECTRICAL WORK OF THE YEAR

Sent to your Home FREE on approval for 7 days

If YOU work in Any Branch of the Electrical Industry YOU NEED THIS NEW BOOK

The FIRST and ONLY Book of its kind

The Electrical Encyclopedia

A Handbook of Modern Electrical Practice for the Working Electrician

4 Volumes . . . 1,480 Pages . . . Over 2,300 Illustrations

General Editor: S. G. BLANLAND STUBBS
Assisted by 6 Expert Associate Editors and
32 Highly Qualified Contributors

THIS comprehensive work contains sound, up-to-date, authoritative information written by experts in every branch of the profession, and covers thousands of problems and questions of everyday work. The rapid development of electric technology means an enormous increase of opportunities for the electrical engineer who keeps abreast of advancing knowledge. YOU can seize these new opportunities NOW by the aid of "The Electrical Encyclopedia." Whatever your particular subject or job this work will add to your efficiency and aid your advance in your profession.

GIFT BOOK
Valuable 66 - page Pocket Book of Reference Tables Presented FREE to all Purchasers.

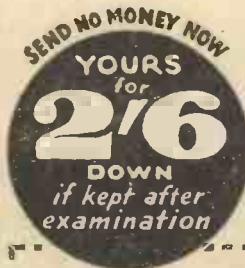

Just sign and post the form below and we will send you these four volumes carriage paid, to examine for one week free. You may either return them to us, carriage forward, within eight days, to end the matter, or you may keep them on the very easy terms outlined on the form.

"Practical and Amateur Wireless" FREE Examination Form
To the WAVERLEY BOOK CO., LIMITED,
96 and 97, Farringdon Street, LONDON, E.C.4.

Please send me, carriage paid, for seven days' FREE Examination, "THE ELECTRICAL ENCYCLOPEDIA," complete in four volumes. It is understood that I may return the work on the eighth day after I receive it, and that there the matter ends. If I decide to keep the books I will send you on the eighth day a First Payment of 2/6, and, beginning thirty days after, thirteen further monthly payments of 5/- each and a final one of 6/-, thus completing the purchase price.
(Price for Cash on the eighth day, 70/-.)

Name

Address

Occupation

Parent's signature required under 21

State if householder Date

Pr. W. 8. PLEASE FILL IN ALL PARTICULARS ASKED.

Valuable New Part Work for Builders and Architects

TO BE COMPLETED IN ABOUT 40 WEEKLY PARTS

"Modern

PART 1 ON SALE TO-DAY

Building Practice" 1/-

WEEKLY PARTS

Edited by PERCY E. THOMAS, Pres. R.I.B.A.

THIS great new Part Publication provides an up-to-date, comprehensive work of reference for the busy Architect and Builder, and also for the young man in Building or Architecture who hopes one day to hold a position of responsibility.

"MODERN BUILDING PRACTICE" gives you the very latest methods in all branches, from the initial planning and designing, to the work of construction and the provision of the final equipment. No matter whether you are mainly concerned with the building of small property, speculative building or important contract work, you will find "MODERN BUILDING PRACTICE" invaluable.

"MODERN BUILDING PRACTICE" will contain over 2,000 practical illustrations, plans, elevations, photographs and diagrams, and many tables and data. CONTRIBUTORS INCLUDE FAMOUS ARCHITECTS AND BUILDING AUTHORITIES.

FREE!

PRACTICAL DATA CHARTS inside each weekly issue. With Part 1 CONCRETE FOUNDATIONS

A vast amount of authoritative information never before collected together in so convenient a form for the practical man.

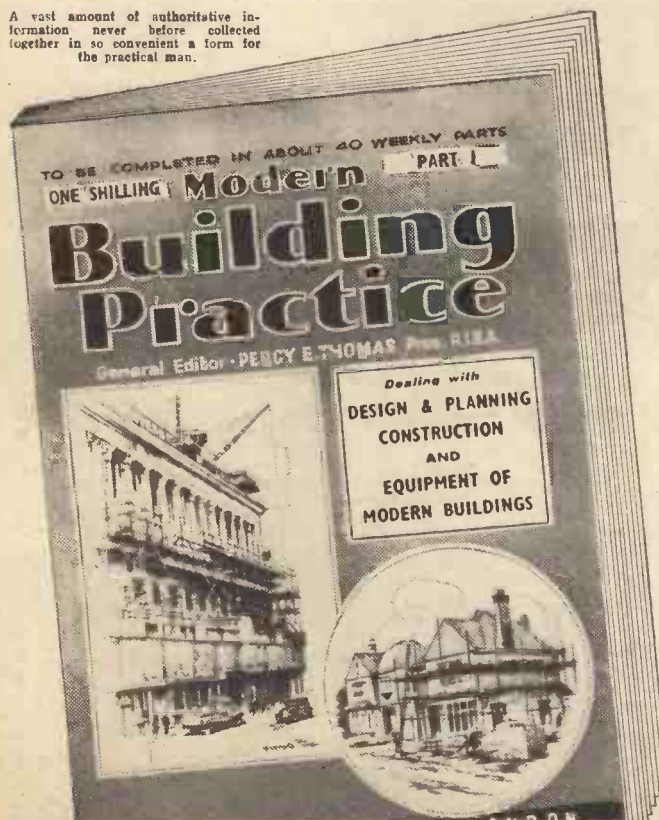

SPECIAL CONTENTS INCLUDE:

DESIGN AND PLANNING

Design and Planning of Housing Estates. All types of Houses, Flats, Shops, Stores, Works, and Factories, Banks and Offices, Cinemas, Theatres and Concert Halls, Garages, Civic Buildings, Hotels and Public Houses, Aerodromes, Restaurants and Cafés, Swimming Baths, Ice Rinks, etc.—Interior Decoration, Acoustics, Lighting Schemes, Time and Progress Schedule, etc.

MATERIALS AND OPERATIONS

Bricks and Brickwork, Timbers used in Building, Metals, Preservation of Metals, Stones, Marbles, Limes, Cements, Mortars, Plasters, Damp-proof Materials, Breeze and Composition Slabs, Concreting, Plastering, Roughcast, Flooring, Special Wall Finishes, Sound and Heat Insulating, Glass and Glazing, etc.

EQUIPMENT OF BUILDINGS

Planning a Drainage System, Sanitation for Rural Districts, Drainage Systems for Motor Garages and Chemical Works, Surveys and Reports, Water Supply, Central-Heating Systems, Ventilation, Gas Fitting, Gas-Heated Hot-Water Apparatus, Gas Fires, Refrigerators, Cooking, Lighting, Electrical supply and Electrical Equipment, etc.
Also Comprehensive Legal Section, the Duties of Clerk of Works, Builders' Estimates, etc.

BUILDING CONSTRUCTION

Builders' Plant and Power Tools, Foundations and Footings, Cement and Concrete, Brickwork, Masonry, Scaffolding, Flooring, Walls and Partitions, Ceiling Coverings, Fire-proof Construction, Doors, Windows, Roofs, Slating and Tiling, Flues and Chimneys, Structural Steelwork, Reinforced Concrete, Bank and Office Fittings, Church Fittings, etc.

FILL UP THIS FORM NOW!

Here, for your convenience, is an Order Form to hand to your Newsagent

ORDER FORM

To Newsagent
Please supply each week until countermanded one copy of Newnes' Important New Part Work "MODERN BUILDING PRACTICE," 1/- weekly.
Name
Address

"MODERN BUILDING PRACTICE" is also obtainable direct from the Publishers, Geo. Newnes, Ltd., 8-11, Southampton Street, Strand, London, W.C.2. (1/2d. each part post free.)

A PAGE OF PRACTICAL HINTS

SUBMIT YOUR IDEA

READERS WRINKLES

THE HALF-GUINEA PAGE

An Improved Resistance Holder

FROM time to time particulars have been published for the making of resistances with graphite, Indian ink, and similar substances coated on paper. I have frequently

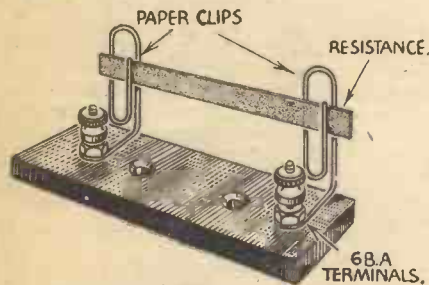

A simple but effective resistance holder.

found these very useful, the only difficulty being in connecting up. Drawing-pins were a failure, so I constructed the holder shown in the accompanying diagram. It consists in the main of paper-clips screwed beneath 6 B.A. bolts on a piece of wood or ebonite of a convenient size.—P. BRADSHAW (Petersfield).

Safety-locks for Battery and Mains Receivers

THIS safety locking device can be applied to actuate directly an ordinary 2-pt. or 3-pt. push-pull battery

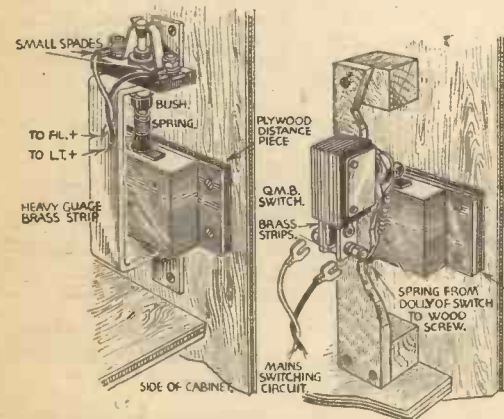

Safety locking devices for battery and mains operated receivers.

on-off switch, and also a Q.M.B. mains on-off switch.

Fig. 1 shows the push-pull switch the plunger of which is placed in the off or safety position when the lock-plunger is extended by the action of the key. When the lock-plunger is withdrawn, the spring on the push-pull plunger ensures the return of the switch to the "on" position. It is necessary first to remove the switch-plunger entirely, and rub it down with emery paper so that it slides easily in the bush, for otherwise the spring may not operate the return. Thin spades are fitted

THAT DODGE OF YOURS!

Every Reader of "PRACTICAL AND AMATEUR WIRELESS" must have originated some little dodge which would interest other readers. Why not pass it on to us? We pay £1-10-0 for the best wrinkle submitted, and for every other item published on this page we will pay half-a-guinea. Turn that idea of yours to account by sending it in to us addressed to the Editor, "PRACTICAL AND AMATEUR WIRELESS," George Newnes, Ltd., 8-11, Southampton Street, Strand, W.C.2. Put your name and address on every item. Please note that every notion sent in must be original. Mark envelopes "Radio Wrinkles." Do NOT enclose Queries with your Wrinkle.

to the connecting wires, so that in the event of the chassis having to be removed from the cabinet these connections can be withdrawn. As they are interchangeable, no difficulty arises as to their reconnection when the chassis is restored. The existing switch in the set may be retained or dispensed with according to individual taste. If removed, the connections are as shown in Fig. 1, but, if retained, L.T.+ valves goes to one contact on present switch, the valves being wired to the other contact.

Fig. 2 depicts the safety-lock for mains receivers. In this case the lock-plunger, when extended, forces the switch-dolly upwards and sets the Q.M.B. switch in the "on" position. When the lock-plunger is withdrawn, the dolly is brought downwards by the strong spring secured to it and to the switch support. To allow of removal of the chassis from the cabinet, small brass extension strips are soldered to the Q.M.B. contacts, and small screw-terminals are secured in these strips. Then spades again form the connecting-links, and are interchangeable.—GORDON BIRRELL (Angus).

A Simple Soldering Clamp

I FIND this simple clamp is invaluable for small soldering jobs. Take a small paper clip of the type shown, cut away the two jaws in the centre, and file the edges smooth.

Two wires or other small parts to be soldered together can quickly be clamped in position with this simple device.—G. OSBORN (West Brompton).

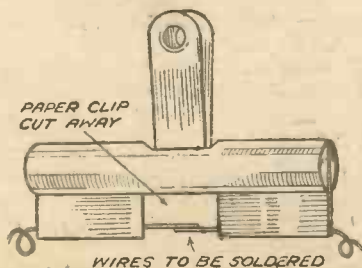

A handy soldering clamp made from a paper clip.

Pilot-light Switching

THE accompanying sketch shows a simple switching arrangement I have successfully used on a set using coils ganged by a common rod. I required a simple S.P.D.T. switch to operate two pilot lights indicating medium and long waves. As indicated, I cut away the front portion of a jack, and flattened the bent part of the moving arm in order to get sufficient length. A small knob with two brass screws inserted at the opposite sides provided a suitable cam to operate the switch. The method of

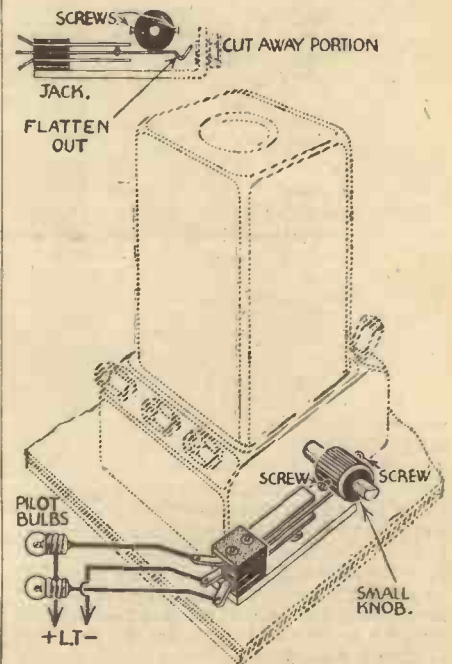

Method of controlling pilot lights from a wave-change switch rod.

fixing the switch is self-explanatory, although a little adjustment may be necessary to prevent the screws on the cam from fouling the upper arm of the jack. Of course, the centre or moving arm is connected to L.T.—, and the remaining two sides to the two pilot lamps.—JOHN H. MORGAN (Dublin).

TELEVISION AND SHORT-WAVE HANDBOOK

By F. J. CAMM

3/6 or 3/10 by post from

George Newnes, Ltd., 8-11, Southampton Street, Strand, W.C.2.

The 'Pilot' All-wave Superhet

A Review of the Model U-650 A.C. Mains Receiver

AS may be seen from the illustration on this page, this new Pilot receiver represents the last word in modern receiver design. Apart from the large full-vision, four-band tuning dial which is fitted, the front of the cabinet also contains a unique tuning device, known as the "Tuning Beacon." This may be seen situated in the centre of the loudspeaker grille. Four controls are provided, two of these being in the form of dual controls. On the left is the volume control and on the right the wave-band selector, whilst the two central knobs control tuning (the upper knob) and a combined on/off and tone control. The tuning knob, in addition to a rotary movement, also incorporates a push-pull movement, and this operates the gear reduction used for turning the condenser. When pulled out a very low gear is employed, a reduction of 95 to 1 being obtained. When pushed in a more rapid movement is provided, the reduction gear being $12\frac{1}{2}$ to 1.

An interesting feature of the tuning dial is the provision of separate sections behind the transparent dial, and each division is provided with its own illuminating device. Thus the scale is divided into two circles, one inside the other, and a horizontal line divides both circles. The lower wave range (from 16 to 52 metres) occupies the outer lower half of the scale, and the next short-wave range (from 48 to 150 metres) occupies the inner lower half. The medium broadcast band (from 175 to 550 metres) occupies the outer top half of the scale and the remaining central portion is taken up by the long waveband from 750 to 2,100 metres. A double-ended pointer traverses the scale, and when the wave-band selector switch is turned to the requisite setting the appropriate lamp is illuminated and only that portion of the dial is illuminated (with the exception that on the medium waves the entire dial is illuminated).

The Circuit

The circuit which is employed in this receiver consists of a more or less standard superhet, with a pentagrid converter following a signal H.F. stage. A variable-

mu pentode I.F. amplifier follows this stage and feeds a double-diode-triode 2nd detector which in turn feeds the output. A comprehensive system of A.V.C. is employed and from this part of the circuit the cathode-ray tuning indicator (the "Tuning Beacon") is fed. Variations of signal strength affect the

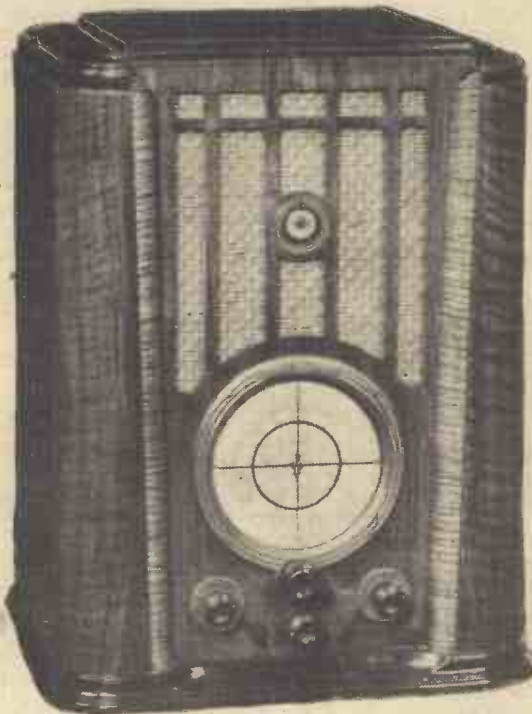

The complete Model U-650 A.C. All-wave Superhet which is reviewed on this page.

radiation from the cathode of this device and a green light which illuminates the outer portion of the mounting of the indicator varies. Tuning is carried out for the maximum green area (or if found simpler to follow, for the smallest dark space). The speaker which is fitted in the receiver is of the mains-energised type, and the field coil is used as a smoothing choke on the H.T. side of the mains supply. A plug is provided so that an external loudspeaker may be employed when desired, and a jack is provided for the connection of a gramophone pick-up.

Test Results

The receiver was tested out without an outside aerial. The short aerial lead which is provided in the receiver was connected to a short length of wire slung across a room, and full volume was obtained on a large number of stations. With the local B.B.C. stations, of course, the volume control had to be set almost to minimum to avoid overloading.

With a full-size outdoor aerial the volume control could not be turned to maximum as the output stage then overloaded and distortion was present. However, long before the overloading point was reached, the volume was more than is required under normal listening conditions. Many stations gave this maximum volume without the volume control being turned to the "full-on" position, and ample programme value was obtained throughout any listening period.

Short Waves

The short-wave performance was above the ordinary, and was, in fact the best which we have yet experienced. Sensitivity was above the average, and the A.V.C. action was sufficient to cope with any but very high speed fading. The American stations could be tuned in during daylight late in the afternoon, and the G.B.C. station on 19 metres was sufficiently powerful to operate the tuning beacon, and the volume control could be set only half way on in order to provide adequate volume. Naturally, noises on the short-waves are troublesome, but the tone control which is fitted enabled the balance of reproduction to be set to such a level that, in conjunction with the volume control, it was possible almost to obtain the American stations free from background and they were as easy to tune and as constant in volume as the local station. The majority of the stations which are named on the dial could be obtained on all four wavebands, and all controls were found to function in a perfectly satisfactory manner. No backlash was experienced, and the wave-range switch was easy in its action and free from noises.

The maximum output, when the last valve is fully loaded, is 3 watts, and the receiver may be thoroughly recommended and will be found very good value at 16 guineas.

Other models are obtainable from 12 gns., and the range includes console and radio-gram models in which a similar radio chassis is employed.

SPECIFICATION

Receiver: All-wave Superhet.

Circuit: Signal H.F. stage, pentagrid frequency changer, H.F. pentode I.F. stage, double-diode-triode second detector and A.V.C. stage, and pentode output stage. Nine tuned circuits, with visual tuning indicator, and resistance-capacity L.F. coupling. Energised loudspeaker, and provision for gramophone pick-up and external loudspeaker.

Tuning covers four wavebands: 16 to 52, 48 to 150, 175 to 550 and 750 to 2,100 metres.

Controls: Four; volume control, wave-band selector, combined on/off switch and tone control, and tuning control. The latter has a two-position setting providing two separate gear ratios— $12\frac{1}{2}$ to 1 and 95 to 1.

Price: 16 guineas, for A.C. mains.

Makers: Pilot Radio Ltd., 87 Park Royal Road, London, N.W.10.

A FINE BOOK FOR THE
BEGINNER!

AND A USEFUL PRESENT

EVERYMAN'S
WIRELESS
BOOK

(2nd Edition)

By F. J. CAMM

3/6 or 3/10 by post from Geo. Newnes,
Ltd., 8-11, Southampton Street, Strand,
London, W.C.2.

THE BRITISH LONG DISTANCE LISTENERS' CLUB

THE lengthening hours of darkness have resulted in a greatly increased bag of really long-distance logs, and some of the reports which are reaching us show that even with a single-valve receiver, some remarkable results may be obtained. We have been testing out some commercial ultra-short-wave receivers during the past week or so, and the tremendous increase in the strength of some of the American stations is no doubt due also to an increase in the power of the transmitters.

Those listeners who have not yet tried the ultra-shorts will be well advised to build up a rough converter or adapter in order to test the suitability of the short-wave receiver. In any case the results will enable one to judge whether or not it is really worth while building a proper short-waver.

Dummy Aerial

Several members have written with regard to the use of a dummy aerial in an endeavour to start transmitting experiments, and some confusion still appears to exist with regard to the meaning of the term. Strictly speaking, it is merely an inductance, a capacity, and a resistance. But this simple arrangement may be improved upon for really elaborate tests, and it is possible to build a unit in which the capacity is variable, the inductance is either changeable or tapped for adjustment, and in which other adjustments are provided. The capacity is connected across the inductance, and the two are connected across the aerial and earth terminals of the apparatus, with a resistance on the earth side.

Aerials for Short-waves

At a radio club recently the problem of the short-wave aerial was raised, and considerable divergence of opinion was found to exist with regard to the type of aerial which gives the best results. Some members held that the dipole was unbeatable, but the opponents of this type of aerial "proved" that this arrangement is only efficient at one definite frequency, and that for all-round results it had to be lengthened and shortened according to the wavelength being received. What have the members of the B.L.D.L.C. found in their own particular cases? It would be interesting if members would write and give details of any tests which they have carried out, especially with a receiver of the all-wave type. Some reliable data should be given, and if possible a parallel test on a given signal with the ordinary and the dipole aerial. It should be remembered, of course, that the dipole must be correctly coupled to the receiver, and there are several ways of doing this. It may be joined to a small coupling coil, fed through variable resistors or through variable condensers.

Television Breakthrough

Considerable difficulty appears to have existed in the vicinity of North London, due to the breakthrough of the television transmissions. Although these are radiated on ultra-shorts from special aerials, it has been found that the signals, both sound and vision, may be heard on the medium

and long waves of a standard broadcast receiver. Statements have been made in the lay Press that the trouble cannot be prevented and that the television transmissions are therefore doomed. This is far from the case, and the simplest of remedies will prevent the trouble. All that is required is a simple ultra-short-wave H.F. choke connected on the input side of the receiver. There are several positions for this, and so long as it is included between the aerial and the grid, of the first valve, it will satisfactorily prevent the ultra-short-

wave breakthrough. In this connection it is interesting to note that both Messrs. Belling-Lee and Bulgin have produced commercial forms of choke for this purpose. The Belling-Lee component is in the form of a plug to be joined to the lead-in and inserted in the aerial socket of the receiver, whilst the Bulgin is in the form of a valve adapter which is inserted between the valve and the valveholder. The choke is wound round the adapter and is wired in the grid circuit.

Mr. Barrs Replies

We have received the following letter from Mr. Barrs in reply to Mr. Logan's criticism of his action in taking station W8XK for test purposes:—

Sir,—Re E. Logan's letter in PRACTICAL AND AMATEUR WIRELESS dated October 10th, 1936, he asks why I have chosen W8XK. Well, the reason is simple; as it

PETO-SCOTT EVERYTHING RADIO—CASH C.O.D. or EASY TERMS

RADIO for 5/- DOWN DIRECT to YOU
SPECIAL OFFER BRAND NEW LAST SEASON'S Peto-Scott TYPE "H" S.G.3 BATTERY RECEIVERS



LIST PRICE £6:12:6
CLEARANCE PRICE £4:4:0

Gives a wide choice of foreign stations with amazing perfection of tone and volume. Built with all high quality components, including Peto-Scott Moving-Coil Speaker, SCREENED COILS, high efficiency S.G.3, Detector and Pentode output valves. Low H.T. consumption. Full-vision scale. Modern Walnut Cabinet. British valves of guaranteed life. Ready to play. Complete with Oldham Accumulator and H.T. Batteries. Cash or C.O.D. Carriage Paid. 2/4 0, or 5/- down and 11 monthly payments of 8/-

Components, Kits, Receivers or Accessories for Cash or C.O.D. or on our own system of Easy Payments. C.O.D. Orders value over 10/- sent carriage and post charges paid (GT. BRITAIN ONLY)

LIMIT ALL-WAVE 4

KIT "A" Authors' Kit of first specified parts, less valves, cabinet and speaker. Cash or C.O.D. Carriage paid, 2/4:16:6 or 12 monthly payments of 8/9. With 4 specified cables. Cash or C.O.D. Carriage Paid, 2/6:3:0 or 12 monthly payments of 11/3.

Receive the new TELEVISION SOUND PROGRAMMES on your SET

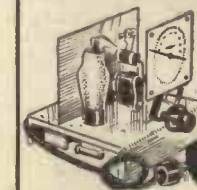

Peto-Scott 6-9 METRE CONVERTER KIT

The ideal method of adapting your A.C. mains receiver so that it will receive the sound programmes of the Television broadcasts from Alexandra Palace. Only 4 connections, and no alterations to your set necessary.

- Employs Hexode valves that operate as 1st Det. and also as Frequency Changer.
- Pressed grey enamelled steel chassis.
- Dual ratio slow-motion airplane dial.

KIT 'A' 30/- All parts, less valves. Or 5/- down and 7 monthly payments of 4/-

TALK to your FRIENDS by RADIO

Peto-Scott PORTABLE 5-metre TRANSMITTERS and RECEIVES TRANSCEIVER KIT

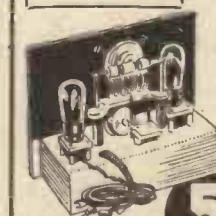

What a thrill! What a hobby! What a pastime! Imagine the delight in establishing radio communication with your friends—there's tremendous fun and entertainment in it. Start building your Transceiver now. Full Building and Operating Instructions with every Kit.

KIT 'A' £2:12:6 Cash or C.O.D. Carriage Paid, Or 5/- down and 11 monthly payments of 4/10. Comprising drilled steel chassis and black panel, all necessary parts, including microphone, less valves, cabinet and batteries.

- SENSITIVE MICROPHONE in spring mounting.
- TELEPHONE JACK
- SPECIALLY DESIGNED TRANSFORMERS for 5-metre band.
- ENTIRELY SELF-CONTAINED (except aerial.)

Fully described in Booklet "B."

NEW AND DIFFERENT! PETO-SCOTT 1937 SHORT-WAVE ADAPTOR - CONVERTER KIT

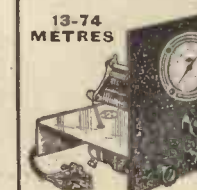

Convert your existing Battery or A.C. set for operation on the short waves with this up-to-the-minute unit. No alterations to your set whatsoever. Two hours to build—a lifetime of world-wide entertainment.

KIT "A" 29/6

Cash or C.O.D. Carr. Paid. Or 2/6 down and 10 monthly payments of 3/-.

Comprises all parts for building, with diagram, assembly, and operating instructions, less cabinet. Fully described in Booklet "B."

Peto-Scott 1937 PERMANENT-MAGNET MOVING-COIL SPEAKERS

MODEL 100. A wonderfully efficient model giving high fidelity reproduction. 6 1/2 in. dia. Power, Super Power or Pentode outputs. Cash or C.O.D. Carriage Paid, 15/6 Or 2/6 down and 6 monthly payments of 2/6.

MODEL 101. 8 in. dia. For Power, Super Power and Pentode outputs and 2 ohms low resistance. Cash or C.O.D. Carriage Paid, 19/6 Or 2/6 down & 8 monthly payments 2/6.

Full range of Peto-Scott Speakers is described in Booklet "B."

FREE TO CONSTRUCTORS

Send this Coupon for your FREE COPY of the following:—
(a) BOOKLET "B"—describes complete range of Peto-Scott 1937 Productions (Kits, Speakers, Eliminators, etc.).
(b) BOOKLET "D"—full wiring diagrams of 4 Tested Circuits. (Strike out one not required.)

PETO-SCOTT CO., LTD., 77 (P.W.6) CITY ROAD, LONDON, E.C.1. Class. 9875. WEST-END : 82 (P.W.6), HIGH HOLBORN, LONDON, W.C.1. Holborn 3248.

Name
Address

EST. 1919.

was the first try-out of the scheme I chose a station that most SWL's had logged, hoping to get their support for the scheme. But it turned out different. I did not get the amount I thought I would with a well-known station like W8XK. Incidentally, I would like to mention that if E. Logan would kindly refer back to *Wireless Magazine*, dated June, 1936, page 337, he will see why W8XK has stopped sending out QSL's. There is no reason for W8XK to be on the "Black List." Also, I have not asked them to QSL by the usual way. I have asked them to kindly send an "official letter of thanks" to SWL's who helped.

Now the scheme is under way, the next stations to be chosen will be those that require reports, and not (like W8XK) those that are received daily.—E. A. J. Barrs, B.L.D.L.C.3260, B.S.W.L.236.

Japanese Stations

Sir,—I have just received a verification card from the Tokio short-wave stations, on which is given the following information, which will no doubt be of interest to readers. Power—20 kW for all stations. Time in G.M.T.

(1) Overseas broadcast for North America, Hawaii, etc.

JUN. 10660 kc/s. Beam Antenna.
JUH. 14600 kc/s. Beam Antenna.

Programme :—
05.00-06.00. News in English and Japanese, Music, Entertainment, Lecture, etc.

(2) Relaying broadcast for Manchukuo and Formosa.

Transmitter :—
JUT. 6750 kc/s. Vertical doublet Antenna.
JUP. 7510 kc/s. Vertical doublet Antenna.
JUN. 10660 kc/s. Vertical doublet Antenna.
JUM. 10740 kc/s. Vertical doublet Antenna.

Programme :—
00.00-00.10. Weather Forecast, Market Quotations.
02.40-02.45. Market Quotations.
03.40-04.10. News, Market Quotations.
06.50-07.20. Market Quotations, News.

09.00-12.30. Children's Hour, News, Lecture, Entertainment.
22.20-22.40. Physical Exercises.

(3) Overseas broadcasting test.
JUP. 7510 kc/s. Beam Antenna.
JUN. 10660 kc/s. Beam Antenna.
JUM. 10740 kc/s. Beam Antenna.
JUH. 14600 kc/s. Beam Antenna.

Programme :—
(1) For East coast of N. and S. America. 21.00-22.00. Announcement, records, etc.
(2) For Europe. 19.00-20.00. Announcement, records.
—F. P. Cawson (Southport).

Regarding QSLs

Sir,—It may interest readers to know that over four months ago I sent off a veri. to SM5SX Sweden, and have only just received a reply. I did not send an international reply coupon. I also sent a veri. to a South American station, and received a reply in a few days together with a sheaf of travel pictures and guides to S.A.—also without a reply coupon. The pictures were sent by registered mail!—DOUGLAS SMART.

RECORD ALL-WAVE THREE

(Continued from page 155)

to the components which are themselves provided with terminals.

There is no drilling or soldering; all constructional work may be carried out with a screwdriver and a pair of pliers for cutting the wire.

In the list of parts to be given next week I have included prices and even the number of screws and their sizes necessary for securing the parts to the baseboard.

Construction may be completed in only one hour!

The circuit is a standard H.F. detector and pentode, and the tuning condenser selected is of a special design which enables maximum results to be obtained on each band.

The selectivity is excellent, and the performance on each waveband is uniformly good.

Those who have been writing to me stressing the advantages of baseboard construction, as well as beginners, who feel that I have somewhat neglected, have their chance next week.

It will help us if you would order your copy now.

Make sure of a long life-



Use
"SPARTA" H.T.
BATTERIES BY

FULLER

The hall mark of quality

Fuller 120 volt H.T. Dry Batteries from 6/- to 16/-.

Dealers everywhere stock them

For the Ideal Combination use a Fuller L.T. Accumulator—Type LDGH at the reduced price of 9/3.

The Fuller Accumulator Co. (1926) Ltd., Chadwell Heath, Essex
Phone: Seven Kings 1200 Grams: Fuller, Chadwell Heath

Type
F 25
Price 7/6

The HOME MECHANIC ENCYCLOPAEDIA

by
F. J. CAMM
(Editor of
"Practical and Amateur Wireless," etc.)



An up-to-date and comprehensive guide to the Mechanical, Scientific and Technical Interest of the day—with expert articles on Aircraft, Television, Models, Astronomy, Electricity, Photography, Chemistry, Woodwork, Motor Cars, Wireless, Home Cinema, with over 600 illustrations.

Only **3/6** net From All Booksellers

Get One To-day!

4/- post free from the Publishers—Book Dept., George Newnes, Ltd., 8-11, Southampton Street, Strand, London, W.C.2

NEWNES : LONDON

The ELECTRON MULTIPLIER

An Interesting Account of the Latest Valve Development

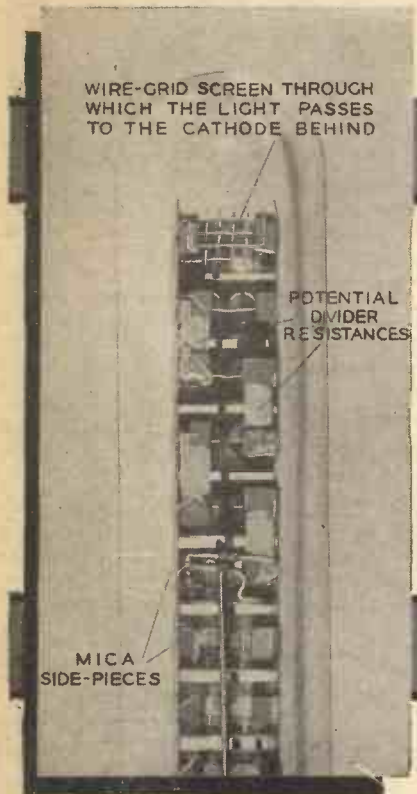

Fig. 1.—An enlarged view of the upper end of the multiplier. The cathode is the top element, and some of the potential divider resistances may be seen connecting the screens.

CONTRARY to popular belief, there is a fairly definite limitation to the amount of amplification which can usefully be obtained from a multi-valve amplifier on account of the thermionic noises which are generated in the valves themselves, and when the input signal is so small as to be comparable with the valve noises of the first stage, it is obvious that any amount of amplification will not succeed in making the signal more audible above the noises of the valves.

It will be realised that the behaviour of the first tube of a multi-valve amplifier and its associated couplings must be extremely regular if it is to produce only inappreciable noises at the output. For example, assume an amplifier which multiplies the input voltage by 100,000; suppose that the first plate circuit has an impedance of 50,000 ohms and that a signal of .02 volt is sufficient to give an audible sound from the loudspeaker. On this basis, a change in the current passing through the first valve of only 10^{-11} —or one hundred-millionth of a milliampere—will produce an audible noise if the change occurs suddenly.

Thermal Effect

If we remember the surface conditions of the hot filament from which the electrons are being "boiled-out," it is not difficult to realise that some irregularity is inevitable. Besides this thermal effect, there are two other causes of noise known as the shot effect and the ionisation effect.

This limitation of the degree of amplification possible with the conventional type of thermionic valve renders the invention of the Electron Multiplier, by Dr. V. K. Zworykin, of the Radio Corporation of America, a matter of unique interest on account of the fact that the noise level is between 60 and 100 times lower than in an ordinary valve, and a much greater

degree of amplification can thus be usefully employed. This feature alone would entitle the electron multiplier to be regarded as a highly important development in high-gain amplifiers, but when it is taken together with the fact that ten or more stages of amplification producing gains of the order of several millions can easily be incorporated in a single tube, it is indeed difficult to foretell the influence which the principle of the electron multiplier may have on the future development of thermionic tubes and radio practice in general.

The Principle of the Electron Multiplier

It has been known for many years that

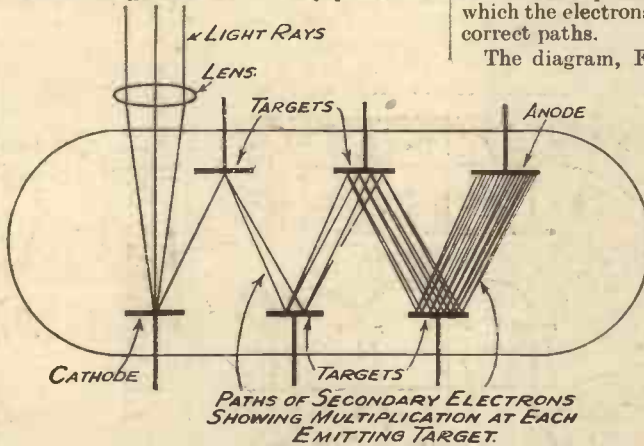

Fig. 2.—A diagram showing how the electrons are "focused" into their correct paths.

when an electron collides with a surface, the impact sometimes causes the emission of a number of secondary electrons from the surface, rather like the effect of dropping a golf ball on to a heap of other golf balls

at rest on the ground, some of which would be made to jump into the air. These secondary electrons are an unmitigated nuisance in the ordinary valve, and innumerable devices have been invented to avoid their effects. In the electron multiplier, however, their production is encouraged by the use of suitable emitting surfaces which emit eight or ten secondary electrons for every initial one striking the surface. These eight or ten secondaries are then "focused" on to a second emitting "target," where each one liberates a further eight or ten secondaries. This process is repeated many times in successive stages. The whole art of this achievement has been the perfection of the technique by which the electrons are "focused" into their correct paths.

The diagram, Fig. 2, shows the general principle, and it will be clear that if suitable means were adopted to control the number of electrons passing between the cathode and the first target, very great amplification is possible. The electrons from the cathode are attracted to the first target by the application of a positive potential to the target, and a still higher positive potential on the second target attracts the secondaries released at the first. Unfortunately this simple arrangement would not work in practice for the simple reason that the highest positive potential is applied to the last target, and any electrons released from the cathode would be immediately attracted

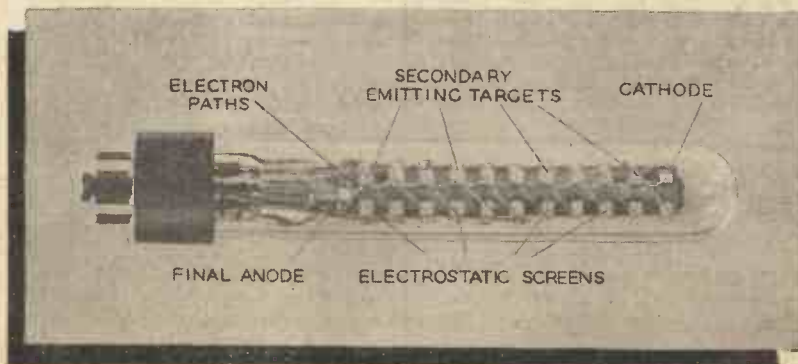

Fig. 3.—This illustration shows the ten-stage electron multiplier.

right down the tube without passing through the various intermediate stages of amplification.

A) Surface for the Targets

The difficulties, therefore, were firstly to find a suitable surface for the targets which would emit a large number of secondaries for every initial impact, and then to guide the electron stream so that all the electrons impinge on the succeeding target.

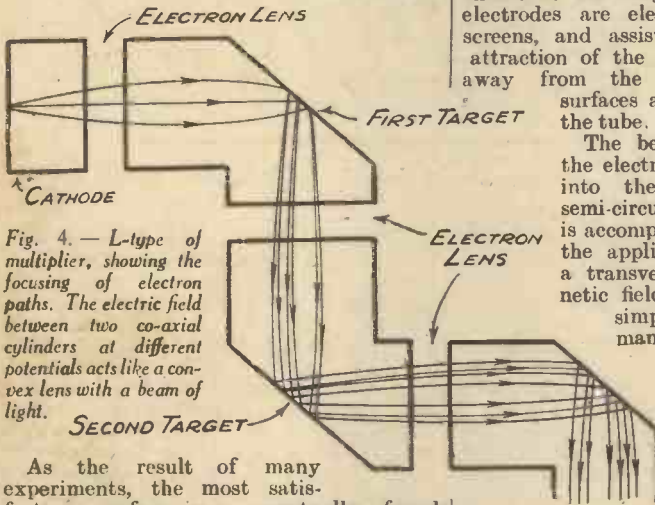

Fig. 4.—L-type of multiplier, showing the focusing of electron paths. The electric field between two co-axial cylinders at different potentials acts like a convex lens with a beam of light.

As the result of many experiments, the most satisfactory surface was eventually found to consist of caesium oxide on a silver base. It is prepared by oxidising a matt silver surface, coating the silver oxide with caesium, and then heating the surface in a vacuum so that the oxygen is transferred from the silver oxide to the caesium. This surface is very similar to that used in photo-electric cells, and this circumstance is not unconnected with the fact that the first electron multipliers have been designed as amplifiers for photo-electric cells.

The second difficulty, that of focusing the electrons into the desired paths, was a more difficult problem. The first multipliers were of the type shown in Fig. 4. The electrons emitted at the cathode were attracted to the first target by means of a positive potential on the target, and scattering of the electrons is prevented by means of the electro-static field between the two short cylinders which form the emitter and target respectively. The difference in potential between the two cylinders produces a radially symmetrical field within the cylinder, and this field focuses the electrons in exactly the same way in which a double-convex lens would focus a beam of light. The secondary electrons released at the first target are attracted and focused on to the second target in exactly the same manner.

The "T"-Type Multiplier

Another type of multiplier, known as the "T" type, is shown in Fig. 6. Both the "T" and "L" types just described require a potential of about 300 volts between each target, and give an amplification of about 8 per stage.

Although it is obviously possible to build

up a multi-stage amplifier of the "L" or "T" type, they are not very convenient forms of construction for a multi-stage tube, and the more simple arrangement shown in Fig. 5 was eventually adopted. It will be observed that the electrons are made to describe semi-circular paths between the successive targets.

In Fig. 5 the caesium oxide emitting surfaces are those along the bottom row, and the multiplication of the electrons is shown in the diagram. The top set of electrodes are electrostatic screens, and assist in the attraction of the electrons away from the emitting surfaces and along the tube.

The bending of the electron paths into the desired semi-circular form is accomplished by the application of a transverse magnetic field from a simple permanent magnet arranged with its poles on either side of the tube so that the lines of force pass between the targets and the screens—that is, perpendicu-

larly to the plane of the paper. The electrical connections are shown in Fig. 7, from which it will be seen that each target has an increasing positive potential, obtained from the potential dividing system of resistances. The screens are each connected to the succeeding targets as shown,

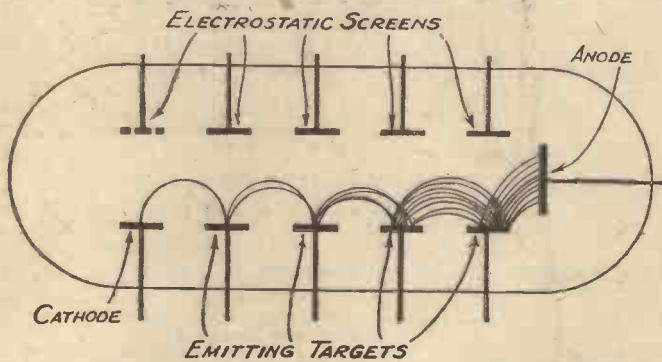

Fig. 5.—Electron paths and principles of a practical electron multiplier.

and the total overall potential required is of the order of 1,500 volts.

It will be noted that part of the potential divider system of resistances is shown within the tube in Fig. 7. It was found possible to incorporate them within the tube—some of them may be seen in the enlarged photograph, Fig. 1, and this arrangement has the advantage of reducing the number of leads to be taken through the glass bulb.

Photo-electric Amplifiers

As was mentioned earlier, these first electron multipliers have been developed as photo-electric amplifiers and the emitting cathode is actually a photo-sensitive

surface. Under the action of light, electrons are emitted which are amplified in the succeeding stages. To give some idea of the performance, it may be mentioned that at a recent demonstration the varying light from a feeble neon lamp operated by a gramophone pick-up was sufficient to operate the photo-sensitive cathode of the multiplier at a distance of about 4ft., and the output from the multiplier was sufficient to operate a moving-coil loudspeaker without further

amplification at sufficient volume to fill a large hall. But if this demonstration was insufficient to convince the audience of

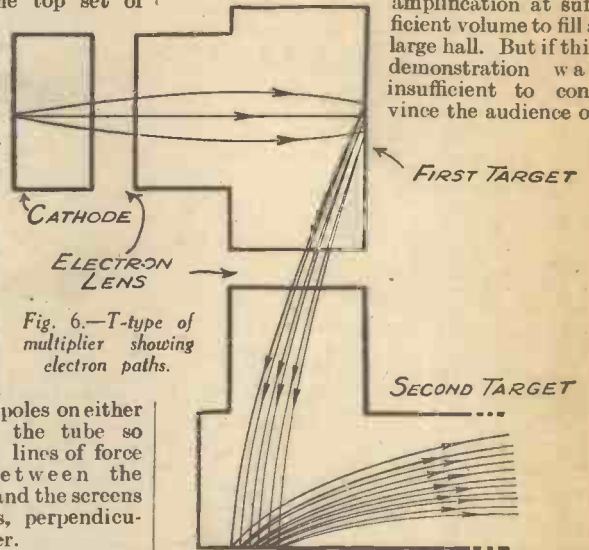

Fig. 6.—T-type of multiplier showing electron paths.

the amazing possibilities of the tube, which, by the way, only measures 7in. in length and 1in. in diameter, the absolute silence of the loudspeaker when the beam of light from the neon lamp was interrupted most certainly was. There was none of the valve noise, hissing and crackle, such as one would expect from a conventional amplifier with a magnification of several million, and it was clear that much greater amplification is a practical possibility by the addition of further stages before the limits imposed by the electron noises are reached.

As has been stated, these first electron multipliers have been designed as photo-electric amplifiers, but there is nothing in the principle which makes it unsuitable in any way as a replacement for the conventional thermionic amplifier, provided, of course, that the electrons passing from the cathode to the first target are controlled in a suitable manner by the incorporation of an arrangement analogous with the grid of an ordinary valve. Experiments are now proceeding in this direction, and especially in view of the very flat frequency characteristic between direct current and many megacycles we can look forward to some interesting developments.

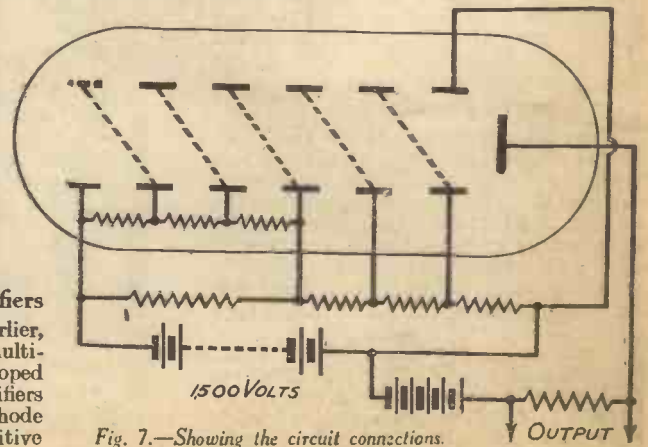

Fig. 7.—Showing the circuit connections.

THREE INTERESTING PUBLICATIONS

"THE ROMANCE OF NATURE"

In every wood, by the hedgerows, and on the cliffs and shore, live little communities of wild creatures. Some, like the badger, or the golden eagle, are rarely seen. Nevertheless, they are there, like the fox and the squirrel, the thrush and the owl, living their simple lives; love-making, home-making, rearing their families, and hunting for food, playing and quarrelling.

Fascinating stories are to be told of the ways and habits of the wild creatures, and on October 30th appears "The Romance of Nature," a wonderful new part work dealing with the wild life of the British Isles in picture and story.

It is edited by Miss Frances Pitt, perhaps the best-known English writer on Natural

"MODERN BUILDING PRACTICE"

If you are connected with the Building Trades, or are an Architect or an Architectural Student, you will be intensely interested in "MODERN BUILDING PRACTICE," a valuable new weekly part publication which is now on sale at all newsagents and bookstalls.

Complete in about 40 weekly parts, this work contains the very latest methods in all branches of Building Practice, from the initial planning and designing to the work of construction and the provision of the final equipment. Celebrated Architects and Building Authorities contribute to its pages, and there will be over 2,000 practical illustrations, plans, elevations, photographs, diagrams and tables. Each weekly issue throughout will also contain a practical Data Chart. With Part 1 is given a Data Chart on Concrete Foundations.

Be sure to ask for "MODERN BUILDING PRACTICE" at your newsagents. It costs only 1s. per part. It is worth pounds to every live man in the Building and Allied Industries.

MARVELS OF MODERN SCIENCE

By F. I. Camm

THE well-known Editor of "Practical Mechanics," etc., has here collected for boys and their parents, too, an assembly of articles and pictures describing the wonders of television, infra-red photography, wireless, invisible rays, sending pictures by telephone, etc. From all booksellers, 3/6 net or 4/- post free. **GEORGE NEWNES, LTD.,** 8-11, Southampton St., Strand, London, W.C.2.



History. Often she has undertaken a journey of many hundreds of miles on hearing tidings of some interesting bird or animal. She has gathered together a band of well-known field naturalists as contributors to this work and they have some wonderful stories to tell.

A leading feature of "The Romance of Nature" is the magnificent collection of camera studies, specially obtained for this work. Many of the photographs have involved days and sometimes weeks of

waiting and watching before they could be taken. In one case a year passed before success rewarded the photographer. In some cases it has been necessary to arrange cunning devices by means of which some particularly shy creature took his or her own portrait.

More than a thousand specially selected photographs will be reproduced, forming a collection unique of its kind. There will be included, also, many colour plates from original studies of animals and birds by well-known artists. To ensure perfection of reproduction, text and illustrations are printed on the finest art paper.

"The Romance of Nature" will be completed in about twenty-four fortnightly parts and will form the most beautiful work of Britain's wild life ever produced. Get Part 1 to-day from your newsagent or bookstall, 1s. 3d. per part.

OPEN LETTER TO MR. SOMEBODY AND HIS SON

DEAR SIR.—The natural desire of most parents is to give their children a fair chance in life in the form of a good College Training, also there are many young men who would like to go to College but for some reason are not able to do so. Let us tell you here and now you can get a Complete College Training without having to go anywhere, and at a reasonable monthly fee for tuition. For well over 30 years we have been training students for all the Key positions, by post, in all parts of the world. Distance is nothing when you are studying by your own fireside.

The nature of our business makes us keep in touch with employment requirements, therefore we specialise in preparing students for the good positions which we know exist, and for all the worth-while examinations. Write to us for FREE particulars of any subject which interests you, or if your career is not decided, write and tell us of your likes and dislikes, and we will give you practical advice as to the possibilities of a vocation and how to succeed in it.

You will be under no obligation whatever, it is our pleasure to help.



THE MOST SUCCESSFUL AND MOST PROGRESSIVE COLLEGE IN THE WORLD.

DO ANY OF THESE SUBJECTS INTEREST YOU?

Accountancy
Examinations
Advertising and Sales Management
All Commercial Subjects
A.M.I. Fire E. Exam.
Applied Mechanics
Army Certificates
Auctioneers and Estate Agents
Aviation Engineering
Banking Boilers
Book-keeping Accountancy & Modern Business Methods
B.Sc. (Eng.)
B.Sc. (Estate Management)
Building, Architecture and Clerk of Works
Cambridge Senior School Certificate
Civil Engineering

Civil Service
Commercial Art
Concrete and Structural Engineering
Draughtsmanship, all branches
Engineering, all branches subjects and exams.
General Education
G.P.O. Eng. Dept.
Heating and Ventilating
Industrial Chemistry
Insurance, Mathematics
Matriculation
Metallurgy
Mining, all subjects
Mining, Electrical Engineering
Motor Engineering
Motor Trade
Municipal and County Engineers
Naval Architecture
Pattern Making
Police, Special Course

Preceptors, College of Pumps and Pumping Machinery
Radio Service Engineering
Radio Communication
Road Making and Maintenance
Salesmanship I.S.M.A.
Sanitation
Secretarial Exam.
Shipbuilding
Shorthand (Pitman's)
Structural Engineering
Surveying
Teachers of Handicrafts
Telephony & Telegraphy
Transport Inst. Exams.
Weights and Measures Inspector
Welding
Wireless Telegraphy and Telephony
Works Managers

If you do not see your own requirements above, write to us on any subject.

Also ask for our New Book (Free of Charge) **THE HUMAN MACHINE** Secrets of Success

Dept. 104, THE BENNETT COLLEGE, SHEFFIELD.

NOW IS YOUR CHANCE TO GET INTO A SKILLED KEY POSITION.

ABC of the Modern Receiver—5

THE detector stage is the next in sequence, since we concluded the last article of this series with the coupling and tuning circuit immediately preceding it. In an earlier section of these articles it was explained that the signal as received by the aerial and passed on in amplified form by the high-frequency portion of the set, is a mixture of high and low frequencies—or of the carrier wave and the pulsations which represent the actual sound. The main purpose of the detector is to separate or split up these two sets of vibrations. Let it be understood in the first place that the word detector is not a good one, despite its universal employment; the detector valve "detects" only in so far as it converts the received signals into such

The Detector and Reaction Circuits Simply Explained

cathode to the anode. The grid condenser is charged by the incoming signal voltages, and positive and negative potentials are applied through it to the grid. But each time the grid is made positive in respect of the filament or cathode, current flows through the grid leak. As a result, there is a voltage drop across the leak, in consequence of which the grid end of the leak is made slightly negative. This means that a slight negative bias is applied to the grid, although the end of the grid leak is joined to L.T.+. This has the effect of "wiping-out" one half of the high-frequency fluctuations, so that only the low-frequency voltages actually affect the grid. Their counterpart—in the form of fluctuating H.T. current—is passed on to the anode. In practice, all of the H.F. is not destroyed, but the remainder is prevented from passing on to the L.F. amplifier or speaker.

values of .0002 mfd. and 2 megohms are found to be as good as any. When the detector is required to handle a larger input than that supplied by a single H.F. valve, values of .0001 mfd. and .5 or 1 megohm are generally better.

"Destroying" Unwanted H.F.

The method of preventing "stray" and normally-unwanted high-frequency currents from passing into the amplifier is to connect an H.F. choke next to the anode of the valve, and also to connect a fixed

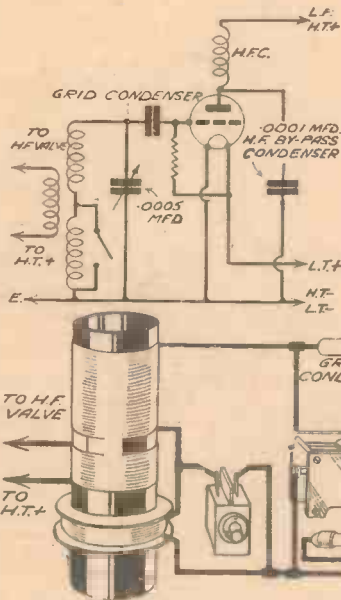

Fig. 1.—Circuit of a leaky-grid detector, or demodulator, valve.

form that the loudspeaker will respond to them.

Demodulation

A better word, and one that has been occasionally used in more technical parlance, is demodulator. This word more closely describes the function of the valve, which is to separate the modulation (sound impulses) from the carrier. To explain in detail and with accuracy the exact method of operation of the demodulator would call for a good deal of highly technical language, as well as the use of a number of graphs and diagrams. Perhaps, therefore, the majority of readers would prefer to have a more general idea in straightforward language. Such is also to be preferred because there are various systems of demodulation, detection or rectification (the last-named word is also used, but is even worse than the second) all of which differ rather appreciably. In the leaky-grid system, shown in Fig. 1, the principal parts concerned with the demodulation are the valve, grid condenser, and grid leak. The valve acts in the same manner as the triode previously dealt with, since the grid controls the electron flow from the

Component Values

The method of prevention will be dealt with later, but a more urgent matter is a consideration of the values of components for the grid condenser and leak. It is possible to calculate these, but for the average type of detector valve (D., H., H.L. or L.) the optimum condenser capacity is between .0001 mfd. and .0003 mfd., whilst the leak should have a resistance between .5 and 3 megohms. For reception on broadcast wavelengths, and using a type H., H.L., or D. valve,

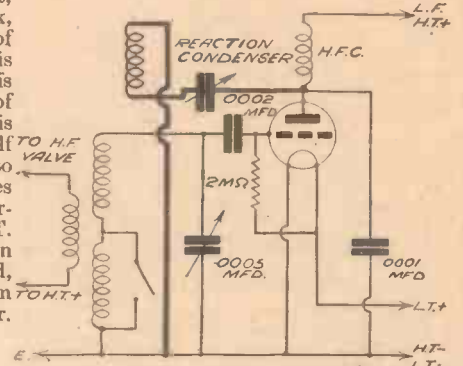

Fig. 2.—Here the reaction circuit is added to the circuit shown in Fig. 1, and is indicated by heavy lines.

condenser of about .0001 mfd. between the anode and earth; both of these are shown in Fig. 1. As has been mentioned before, the choke carries the direct current (H.T.) quite easily, but prevents the flow of H.F. The condenser provides an easy "leakage" path for the H.F., but is a complete insulator to the D.C. In some cases, a fixed resistor is employed in place of the choke, for this has a similar effect; it should have a value of about 10,000 ohms. An objection to its use is that it "drops" a certain amount of H.T. voltage, whilst it is by no means a complete barrier to the H.F. impulses. Incidentally, should the H.F. currents pass into the L.F. portion of the set they cause distortion of various insidious kinds, and sometimes produce unpleasant

resistance between .5 and 3 megohms. For reception on broadcast wavelengths, and using a type H., H.L., or D. valve,

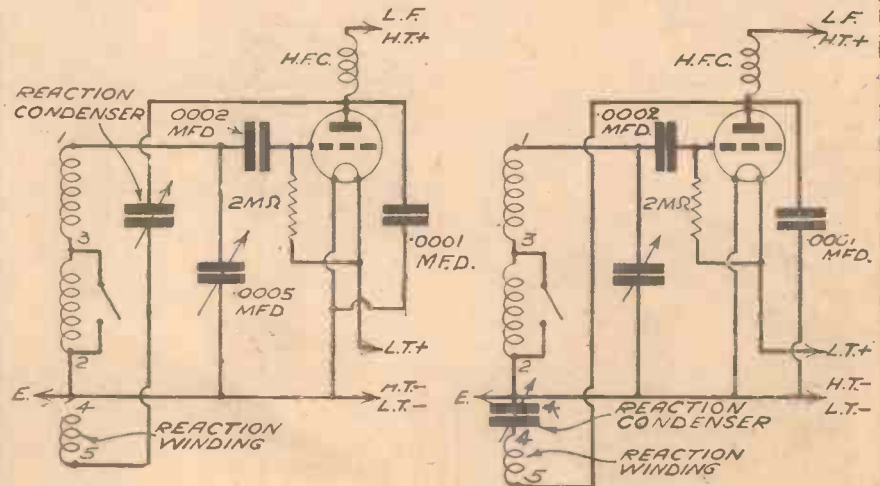

Fig. 3.—These circuits are useful as a means of remembering the correct connections for the reaction winding.

"howls" and "groans," which are not affected by tuning.

Reaction and Oscillation

The reaction circuit is an important part of the detector stage, and it is shown in Fig. 2. There are several slight modifications of the particular connections shown, but all are the same in principle. The main constituents are the reaction winding on the coil and a variable condenser in series with this. These two components are joined between the anode of the valve and earth. As the reaction circuit is on the "valve" side of the H.F. choke, the residual H.F. can pass into it; more or less, according to the capacity of the condenser. And as the reaction winding is situated close to the tuning winding the magnetic field which is developed around it "links up" with the field round the tuned winding. This field is at higher H.F. potential—due to amplification by the valve—and thus high-frequency energy tends to pass from the reaction coil to the grid or tuning coil. In the correct conditions this increases the intensity of the current in the latter, with the result that the input to the grid of the valve is increased. The extent to which it can be increased is dependent upon the amount of energy passing through the reaction coil, and thus upon the setting of the variable reaction condenser. But when the "feed-back," as it is often called, passes a certain limit the valve oscillates, or becomes a miniature generator. As a result, a whistle is heard when the set is tuned to a signal, and proper reception is impossible.

Correct Phase

It was stated above that reaction increases signal strength "in the correct conditions." The main consideration is that the feed-back be in the same "phase" as the signals—in other words, that the

magnetic fields tend to assist each other. This result is achieved when the upper end of the tuning coil is connected to the grid, and the lower end of the reaction coil is connected to the anode (probably through the reaction condenser), as shown in Fig. 2. This assumes that both windings are in the same direction, as they generally are. One simple way of remembering this relationship is by drawing the circuit as shown in Fig. 3, where two alternative positions for the reaction

condenser are indicated. It should, however, be pointed out that no difference is made if the connections to both windings are reversed, although if those to one only are changed signals will be made weaker, instead of stronger, as the capacity of the reaction condenser is increased.

Reaction Condensers

There is no standard capacity for the reaction condenser, since it must be dependent upon the design of the coil—the number of reaction turns and their distance from the tuning winding. Most coils are designed for use with a .0003-mfd. condenser, but a few makers advise a .0002-mfd. component, and still fewer, one of .0005 mfd. The reaction winding is generally divided into two parts, these being in series, one a short distance from the medium-wave tuning winding and the other close to the long-wave section. This is shown quite clearly in Fig. 4, where a typical modern air-core coil is shown. In this case the long-wave reaction and long-wave tuning windings are wound in criss-cross or honeycomb form, although the turns are sometimes placed in a "pile" in slots formed by the use of insulating washers on the tube.

Connections for the coil are shown on the assumption that all turns are wound in the same direction, but the same result would be obtained by reversing the connections to the reaction coil and at the same time reversing the direction of its winding. In the next article of this series the L.F. coupling will be described. This is similar in many respects to the H.F. coupling previously dealt with, but is designed to offer a high impedance at low frequencies, instead of at the signal frequency. There are several forms of coupling—resistance-capacity, choke-capacity transformer and resistance-fed transformer—but the two latter are most frequently used in simple sets.

(To be continued.)

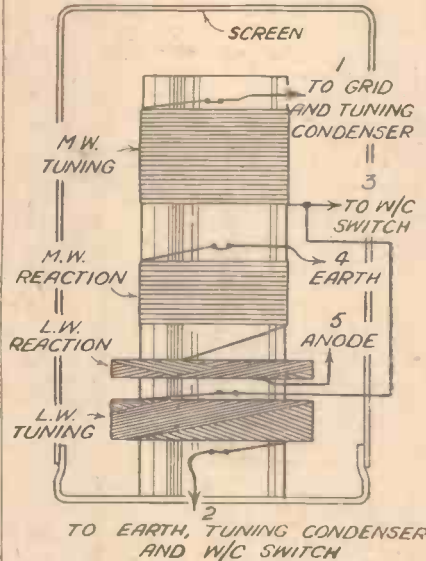
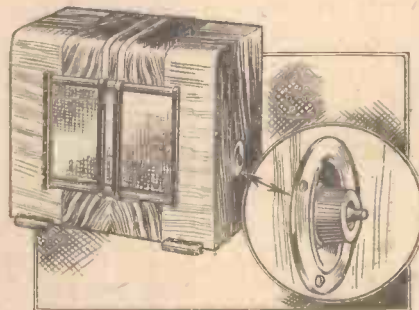
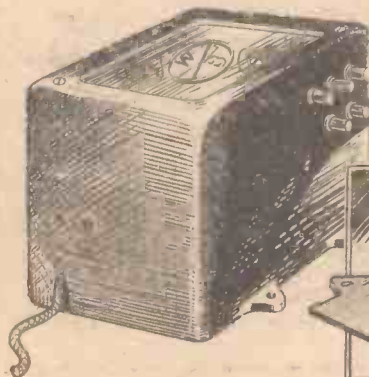

Fig. 4.—A typical air-core tuning coil on which all windings are in the same direction. It shows the disposition of the windings and also the connections. The latter are numbered to correspond with Fig. 3, but it should be explained that the numbering varies considerably in different makes of coil.

NEW SEASON'S NOVELTIES

THE accompanying illustrations show some novel ideas which are seen for the first time this season. The remote control device introduced by W/B, with the self-contained volume control and relay switch mounted on the extension loudspeaker, gives greater scope for room-to-room listening. The high-fidelity earpiece will prove a boon to those who are hard of hearing, as it is usually found that the high-note response is the most important factor in audibility in such

persons. For the operation of a receiver without H.T. the converter unit shown on the right is extremely valuable, and no doubt many developments of this idea



An H.T. supply may be obtained from an accumulator by means of this Ekco converter.



will be seen in the future. Components for the home-construction of a similar unit may be obtained from Messrs. A. F. Bulgín.

On the left is the W/B remote control device, and, above, an extension speaker with self-contained volume control and switch for the relay. On the right is the Ekco high-fidelity earpiece.

Facts and Figures

COMPONENTS TESTED IN OUR NEW LABORATORY

New Brush Microphone

THE novel form of microphone seen at the foot of this column is a new Brush model, incorporating crystal units, and arranged in such a manner that the complete mike is more or less non-directional. In addition to the incorporation of the dual sound cells, a novel form of mounting is adopted, and this is shown in the inset drawing. The cells are housed in small metal containers suspended from an outer ring by double tensioning springs, and the external mounting ring is also slightly springy. Felt distance pieces are fitted, and the units are horizontally disposed, the sectional diagram being in a horizontal direction. The suspended mounting enables the mike to be handled without risk of noise, and the mounting stand may even be carried whilst the amplifier is in action, without any risk of noise. The mounting on the stand is of the rigid type, and the surround is in the form of a wire net permitting sounds to pass in to the crystal units from all directions. Further details and prices may be obtained from the Rothermel Corporation, Canterbury Road, N.W.6.

Variable I.F. Transformers

THE need for a variable selectivity device in a modern superhet has led to the development of various patterns of intermediate-frequency transformer. It is in this part of the superhet that the simplest form of variable selectivity device may be incorporated, and this may take the form, either of a variable condenser coupling both primary and secondary, or some method of moving one coil in relation to the other and thereby modifying the coupling. In the component illustrated in the centre column the latter arrangement is adopted. The transformer is a Sound Sales component, in which primary and secondary are Litz wound on sectioned ebonite bobbins, one being rigidly mounted

condensers, and the other mounted on a spindle passing through the screen. This spindle is extended at both sides, permitting of both external (panel) control and of ganging, when more than one is employed. The transformer is characterised by a rigid assembly, freedom from variations due to

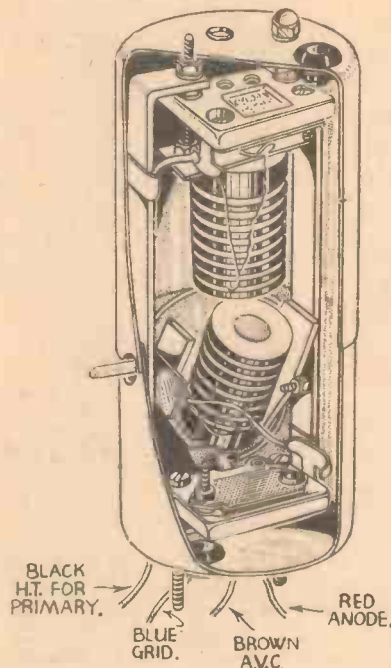

A Variable-selectivity I.F. Unit
made by Sound Sales.

vibrations, etc., and is provided with coloured flexible leads in place of terminal connections. The overall dimensions are 6in. high and 2½in. in diameter, and the price is 10s. The makers are Sound Sales, Ltd., Marlborough Road, Upper Holloway, London, N.19.

Masonite Board

IN a recent issue we stated that Masonite Board was now unobtainable. This information was given as a result of a statement from a firm who were recommended as the source of supply of this material for a loudspeaker cabinet. We are now given to understand by Messrs. Fountain Bros., of Gell

dered Road, Leeds, that the material may still be obtained at many timber merchants and builders' merchants' yards, and that they are the agents for Leeds and district.

Belling-Lee Telefilter

BREAKTHROUGH of the television transmissions on the normal broadcast bands has given rise to considerable trouble in districts close to the Alexandra Palace. Messrs. Belling & Lee have produced a special H.F. choke designed for incorporation in the aerial lead to suppress this type of interference. To facilitate easy connection in the circuit the choke is made

in the form of an elongated wander plug, and this is used at the end of the aerial lead, and may be inserted in the aerial socket on the receiver, thus automatically including the choke in circuit. The overall length of the plug is 3¼in. and it is ½in. in diameter. The price is 2s.

Goltone Suppressor

IN our issue dated October 10th we reviewed a neat suppressor device manufactured by Messrs. Ward & Goldstone. We stated that the price of this was 5s. 6d., but we now are informed that the price has been reduced in the new radio catalogue to 4s. 6d.

The Autolog Chart

A NOVEL tuning chart may be obtained from C. R. Hudson, of 89, Waverley Road, Southsea, Hants. This takes the form of a cardboard approximately 10in. by 4½in., to which is fitted a strut so that it will stand practically vertical. The principal European station names are printed on this log, the long-wave stations in blue in the centre of the chart and the medium-wave stations in red on each side. The wavelengths are, of course, included. Supplied with the chart is a strip of celluloid engraved from 0 to 100 or 0 to 180 (according to the type of tuning dial in use on the receiver). A thin strip of bamboo, two coloured pencils, and two pins are also supplied, and the chart is calibrated in the following manner. Well-known stations are tuned in on your receiver and the celluloid scale (which slides up and down the chart) is moved until the station name coincides with the scale reading on the tuning dial. A pencil mark is made at this point and the procedure is continued for one or two more stations, after which the bamboo strip is placed so that it joins up the strips, the pins helping to keep it



This is the Clock-dial S.M. Drive reviewed in our issue dated Sept. 26th. last.

in position. A curve is thus produced, and with the blue pencil the outline of the bamboo is followed, with a similar curve in red pencil for the long waves. Thereafter, it is only necessary to slide along the scale to obtain the correct dial reading for any station, or conversely to obtain the name of any station which is tuned in but which is not otherwise identified. The price is 1s. 3d. post free, ready to be adjusted, with the pencils, etc. If required ready adjusted, a card may be obtained from Mr. Hudson upon which the dial settings of two or three stations should be entered. For receivers in which wavelength markings are already made, the chart may be obtained without the sliding scale for 7½d.

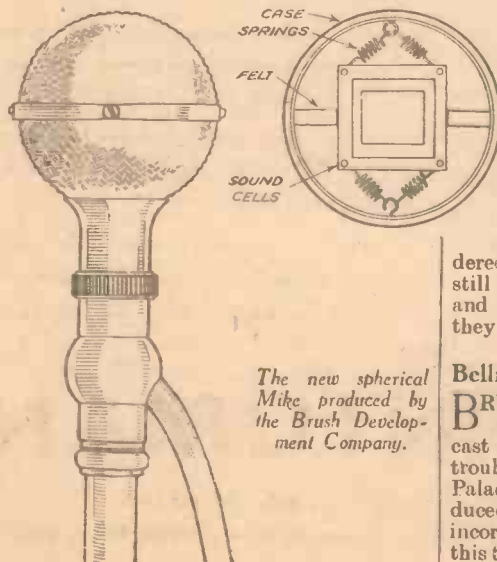

The new spherical Mike produced by the Brush Development Company.

RADIO CLUBS AND SOCIETIES

Club Reports should not exceed 200 words in length and should be received First Post each Monday morning for publication in the following week's issue.

The Deptford Men's Institute Short-wave Radio Society

THIS Society held a 5-metre field day on Sunday, September 27th, and it proved quite a success in spite of rain.

The new session of the Society opened on Tuesday, September 29th, and was well attended. The winter programme was mapped out and this includes morse practice and an elementary course for the beginner. The more experienced amateur will also be catered for, as transmission and ultra-short waves are some of the subjects to be dealt with. The Society is under the instruction of G2UX and possesses the call sign 2BOD. It is hoped to have a full licence very shortly, and a transmitter is in course of construction in readiness. Meetings are held every Tuesday at 8 p.m. at the L.C.C. Clyde Street School, S.E.8. For further details please write to the Sec., J. T. Parker, 48, Nigeria Road, Charlton, S.E.7.

Bradford Short-wave Club

THE above club held its first annual general meeting on Friday, October 2nd, in Bradford Moor Council School, when the officers were elected for 1937. The members have been the participants of two or three interesting visits during the past year, and two field days were held, when those who took part were able to experiment with different types of gear, under adverse conditions. Some interesting lectures and demonstrations are included in the programme for 1937, and the club will be shortly commencing a course for those who wish to learn morse. The club is the Bradford Chapter of the BLDLC, and is also affiliated to the British Short-Wave League. Any BLDLC or BSWL member is cordially invited to the club meetings. Information as to the club's activities will be gladly given on application to the Secretary, Mr. G. Walker, 2AWR, 33, Napier Road, Thornbury, Bradford, Yorks.

The Croydon Radio Society

THIS Society's new session is now well under way, and below are some extracts from the fixture card:—

October 27th: Pick-up evening, all members being requested to bring their models.

November 3rd: Mr. H. L. Sulman, F.I.C., M.Inst.M.M., member, on "A Beginner's Experiences on Short-wave Reception," and a demonstration of his short-wave receiver.

November 10th: The Mullard Wireless Service Co., Ltd., will discuss: "Cathode Ray Tubes, their construction and use," accompanied by a series of interesting lantern slides.

Other good things are coming, including the first loud-speaker night on December 1st. However, PRACTICAL AND AMATEUR WIRELESS readers are asked to apply for a copy of the fixture card, in which full programmes up to Christmas are given in detail.

Hon. Publicity Secretary, E. L. Cumbers, Waycourt, Campden Road, S. Croydon.

The Surrey Radio Contact Club

OWING to the increase in the number of members during recent months, the Surrey Radio Contact Club has found it necessary to move into new quarters, and has taken accommodation at "The Alhambra," 25, Wellesley Road, W. Croydon.

Meetings are held on the second Tuesday in each month, and membership is open to anyone interested in radio reception or transmission on the higher frequencies. An excellent series of lectures has been arranged for the present season, and instruction, both elementary and advanced, is available to members in matters within the scope of the Club.

Anyone interested in joining the Club should apply to the Hon. Secretary, E. C. Taylor, G5XW, at 35, Grant Road, Addiscombe, Croydon, for details of membership.

Wellingborough and District Radio and Television Society

THE first of the new season's meetings of the above Society was held at the Midland Hotel, Wellingborough, on Wednesday, October 7th, when a lecture and demonstration was given by Mr. Webb, of Pye Radio, Cambridge, on the all-wave receiver. This was followed by a demonstration of one of Messrs. Pye's latest models.

Two parties were arranged at the meeting, one to visit the short-wave transmitters at Daventry, and the other to visit the local Telephone Exchange. All PRACTICAL AND AMATEUR WIRELESS readers in the district are invited to attend the meetings of the Society, and particulars and dates of future meetings may be had from the Hon. Secretary, L. F. Parker, G5LP, BSWL54, 127, Jubilee Crescent, Wellingborough, Northants.



"I'll take some beating" says Mr. Wilkes

PRICES

Cabinet Models

37SC (Senior)	63/-
37JC (Junior)	49/6
37CC (Cadet)	39/6
37BC (Baby)	29/6

Chassis Models

37S.	42/-
37J.	32/6
37B.	23/6
37M.	17/6

The larger models are available on Hire Purchase through your dealer. Terms from

7'6 DOWN

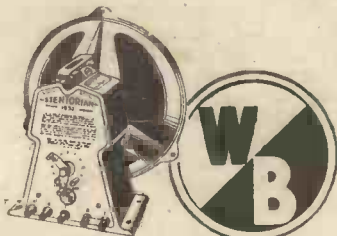

WRITE FOR BOOKLET

1937 STENTORIAN

PERMANENT MAGNET MOVING-COIL SPEAKERS

WHITELEY ELECTRICAL RADIO CO. LTD. (Technical Dept.), MANSFIELD, NOTTS.

"I don't listen much, but when I do—here, listen to this, now! Do you want better?"

Well, we defy the owner of a 1937 Stentorian not to listen much! Radio programmes as rendered by this new speaker have a fascinating sense of reality which has kept many a listener up for "just another half-hour!"

As for "lack of improvement," there are eight enthusiastic designers at Mansfield who will tell you differently. And prove it! This year's advance, they assert, is the most striking they have ever made!

Your dealer has the newest Stentorian in stock. Compare one with your present instrument—whatever it be—and hear for yourself!

Let Us Send You This 40-Page Booklet — Free



It gives full information regarding various I.C.S. Courses of Instruction in Radio work.

The Radio industry is progressing with amazing rapidity. Only by knowing thoroughly the basic principles can pace be kept with it. I.C.S. Instruction includes American broadcasting as well as British wireless practice. It is a modern education, covering every department of the industry.

OUR COURSES

Included in the I.C.S. range are Courses dealing with the Installing of radio sets and, in particular, with their Servicing, which to-day intimately concerns every wireless dealer and his employees. The Equipment Course gives sound instruction in radio principles and practice.

There is also a Course for the Wireless Salesman. This, in addition to inculcating the art of salesmanship, provides that knowledge which enables the salesman to hold his own with the most technical of his customers.

Then there are the Preparatory Courses for the City and Guilds and I.W.T. Exams.

We will be pleased to send you details and free advice on any or all of these subjects. Just fill in, and post the coupon, or write in any other way.

International Correspondence Schools, Ltd.,
Dept. 94, International Buildings,
Kingsway, London, W.C.2.

Without cost, or obligation, please send me your "Radio" booklet of information about the Courses I have marked X

- COMPLETE RADIO
- RADIO SERVICING
- RADIO EQUIPMENT
- RADIO SERVICING AND SALESMANSHIP
- WIRELESS ENGINEERING
- EXAMINATION (state which)

Name..... Age.....

Address.....

LETTERS FROM READERS

The Editor does not necessarily agree with opinions expressed by his correspondents.



All letters must be accompanied by the name and address of the sender (not necessarily for publication.)

A Champion Paper!

SIR,—Last year I built a single-valve short-wave set, from a circuit published in your paper, using standard parts. Being a signaller during the War I took up radio as a hobby after leaving the Service, and during the last seventeen years I have built a few receivers. I built the single-valver in the first place thinking to pass a few odd hours, but a try-out convinced me that though the components were common there was nothing common about the set's performance. A little experimenting with the aerial coupling coil, a pre-fixed condenser in series with the aerial lead, and there are no dead spots on practically any type of aerial. I use the set with a two-valve amplifier R.C.-L.F., triode-pentode output, together with a Stentorian speaker, and the results compare with any set I have ever made using short-wave components. I could fill these pages with last winter's log all on the speaker, including one station that I had tried to log for weeks, viz., VP3MR (42.4 m.), Georgetown. The American stations in signal strength were equal to Rome, about R8, and in my opinion this set, built with care, would surprise many of the old stagers. In the original circuit there was no bandsread condenser, so I made one from a pre-fixed condenser. Allow me to thank you and your staff for giving readers four years of progress and pleasure. As they say in Lancashire, it is a champion paper!—G. KENYON (Blackburn, Lancs).

An Ultra-short-wave Log

SIR,—Perhaps this log of stations heard on the ultra-short waves will be of interest. The receiver is an 0-v-Pen of the Reinartz type, and the aerial is a half-wave dipole on 56 Mc pointing N. and S. Most 56 Mc stations are heard on Sunday mornings: on C.W., G5LB-R8; G2HG-R9; G2GB-R6; G2AW (24w)-R7; G2RD-R7. On 'phones, G5HF-R9; G6OW-R8.

There is also DX. to be heard in the way of harmonics of the lower frequency stations, i.e., GFA6, ZOK, 1RU, and FYT. The 28 Mc band is still very variable. So far I have heard all W districts on 'phones, and CW also LU3DH, LU7AZ, K5AY, VP5AC, CO6ON, CM2FA, FB8AB, ZT2B, ZS6T, ZSIH, ZU1C, ZT6M, VP2AT, VE2EE, VE4IG and VK4AP. South African stations come in very well here, especially ZE1JJ, ZE1JU, ZE1JS. On 31.6 Mc I have heard several of the U.S.A. broadcasting stations, who, unfortunately, heterodyne one another. So far I have identified W9XAZ and W8XWJ. These stations are best heard about 19.00 G.M.T. Finally, the transmissions from Alexandra Palace come in here at R9+.—H. W. PARKER (Ewell, Surrey).

Back Number Wanted

SIR,—I find that PRACTICAL AND AMATEUR WIRELESS, dated December 7th, 1935, is out of print, and would be greatly indebted to any reader who would sell or loan me a copy. I will pay necessary postage, and return the copy in good order.—J. B. LOTHIAN (6, Lyne Street, Edinburgh).

A Tone-compensating L.F. Stage

SIR,—I have been using for some time a circuit of a low-frequency stage which I have developed after a great deal of experiment with values, etc. Using this circuit the reproduction seems more realistic. It principally applies to receivers incorporating two low-frequency stages, but in many cases I think that, once tried, most listeners will prefer to retain it in

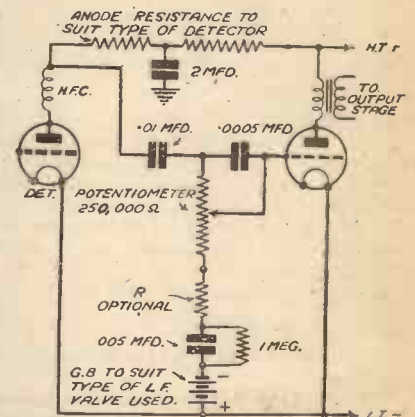

Circuit diagram of a tone-compensating L.F. stage, developed by a reader, Mr. H. Bracegirdle

conjunction with the present popular SG-Det.-L.F. three-valve receiver. In this case it will be better to insert this stage after the detector valve, and before the output stage. The resistance marked R, in the accompanying diagram, is optional, but I found it better to have one about 40,000 ohms as a limiting resistance, as if the slider is set right up to end of a condenser of .005 mf. capacity the tone is too heavy.

Referring again to the circuit diagram, when the slider is set at the top side of the .005 condenser the tone is heavy and the bass notes come out strongly, and when the slider is approximately half-way along the resistance top and bottom notes seem most prominent. When the slider is at the top of the resistance the tone is normal as for an ordinary R.C. stage. As in most cases of tone compensating circuits an overall loss in volume may be expected, but nowadays this can usually be afforded.

The condenser of .0005 mf. is for the purpose of passing the high notes freely to the grid of valve, while the .005 mf. condenser acts as a fluctuating value of resistance in the potentiometer circuit varying with frequency. For instance, at, say, 5,000 cycles the impedance is practically nil, and at low frequency the impedance is high so that in effect at that instant it is equivalent to having the slider of the potentiometer higher up the resistance at that particular moment of time, and therefore low frequencies are emphasised. The short resistance of 1 megohm is merely to ensure that the valve receives negative grid-bias. If a lower value of resistance is used it will upset the working of the .005 condenser.—H. BRACEGIRDLE (Haydock, Lancs).

Crystal Fan's Drastic Experiment

SIR,—This new Droitwich business has cut my lovely crystal set (made with my own hands) right out. Whereas at times I used often to hear music and other noises, I now only hear Droitwich, and, consequently, feel I have wasted my 1s. 6d. (cost of parts).

Friends tell me I should tap the tenth turn, or something, but as I have not the faintest idea where this may be located (between ourselves), I have been using a coal-hammer at random. All I can get now, I am sorry to relate, is a nasty "bang-bang" every time the hammer is brought into circuit. Furthermore, I feel sometimes that my beautiful electro-musical instrument is not being given correct treatment, and I fear that it is slowly being disintegrated before my very eyes.

Will my continued efforts be in time rewarded? Am I likely to get in some sort of trouble with the B.B.C.? Must I forever lie in fear of accidentally splitting the atom? Or what am I doing?—O. K. DOKE (Haystack City).

Correspondent Wanted

SIR,—I should be pleased to get in touch with any reader in my district, or elsewhere, who is interested in short-wave listening and amateur transmitting. In the near future I hope to rig up a low-powered C.W. transmitter on one of the amateur bands.—LESLIE MCGLADE (20, Poolsbrook Road, Duckmanton, nr. Chesterfield, Derbyshire).

CUT THIS OUT EACH WEEK

Do you know

—THAT the voltage output from a pick-up may be measured by connecting a valve-voltmeter and micro-ammeter in the output circuit.

—THAT in modern cabinet making an instrument is employed which measures the moisture content of the wood. It is mains operated.

—THAT when lubricating moving switch parts care must be taken not to use material which will give rise to poor contact.

—THAT on moving metal parts which are actual electrical contacts, fine graphite paste is the best lubricant.

—THAT electrolytic condensers give better smoothing for a given capacity than a paper condenser.

—THAT a delay voltage for an A.V.C. circuit may be taken from a grid bias resistor.

The Editor will be pleased to consider articles of a practical nature suitable for publication in PRACTICAL AND AMATEUR WIRELESS. Such articles should be written on one side of the paper only, and should contain the name and address of the sender. Whilst the Editor does not hold himself responsible for manuscripts, every effort will be made to return them if a stamped and addressed envelope is enclosed. All correspondence intended for the Editor should be addressed to: The Editor, PRACTICAL AND AMATEUR WIRELESS, George Newman, Ltd., 8-11, Southampton Street, Strand, W.C.2.

Owing to the rapid progress in the design of wireless apparatus and to our efforts to keep our readers in touch with the latest developments, we give no warranty that apparatus described in our columns is not the subject of letters patent.



Sandler's New Recording

GRACE MOORE'S latest picture, "The King Steps Out," has its music composed by Fritz Kreisler, the famous violinist. So we have some of this master's most delightful gems—"Caprice Viennois," "Liebeslied" and "Liebesfreud" under new titles in the film. A selection of the music from the film is played by Albert Sandler and his Orchestra on a record just issued—Columbia FB 1487.

Rawicz and Landauer, the two pianists who have played before the King, have made an extremely fine record this month. Hear, first, the "Parade of the Tin Soldiers," and when that has worked its surprise, play "Nola" on the reverse side. This record is available in the eighteen-penny series—Columbia FB 1497.

A Young Corsican Singer

TINO ROSSI, the Corsican singer, who made an outstanding record in the August list (Columbia DB 1649) appears again this month singing what will undoubtedly become a song rage over here soon, "Serenade in the Night" (Un Violon dans la nuit), coupled with "A Serenade to Lena" on Columbia DB 1656.

Unusual New Rumba

A NEW rumba record has just been issued by the Columbia Company. It is a record of Don Miguel and his Cuban Music playing "Cuban Caddy." The music is insinuating, and it is interpreted with a wealth of instrumental colour. Go out of your way to hear this record, which has "El Sombrero de Gaspar" on the reverse. It is Columbia FB 1494.

Rocky Mountaineers

LES ALLEN has joined the Rocky Mountaineers in producing a version of the song hit "Empty Saddles" on Columbia FB 1495. The coupling is the song success from America, "Shoe Shine Boy." Readers will no doubt remember his broadcast of this song from Radiolympia in August.

Turner Layton, whose records are extremely popular, has made two extremely fine records this month. "It's a sin to tell a Lie" and "On the Beach at Bali-Bali"

—Columbia FB 1496—and "The Hills of Old Wyomin" and "Your Heart and Mine"—Columbia FB 1501.

This Month's Variety

THE 1s. 6d. Variety Stars section of the Columbia supplement maintains its high standard of popular names and entertainment, and its vogue is happily spreading each month. Now that the darker nights are here, the October list will be all the more welcome, because it offers a selection from which can be chosen one's own "Variety Hour." There is Debroy Somers and his band in a selection of "Swing Along," the Gaiety show in which he is playing—Columbia DX 750—and a ten-inch selection of "The Gondoliers" on Columbia FB 1483, introducing some nine different items. Gipsy music is enjoying a great vogue these days, and it is good to see two combinations that specialise in this field in the list. Mantovani and his Tipica Orchestra play "Round a Gipsy Camp Fire," on Columbia FB 1500, while Rode and his Tziganes give us a "Gipsy Fantasy" and "Gipsy Drinking Song," on Columbia FB 1488.

An All-star Orchestra

ONE of the most ambitious achievements of the gramophone was the formation, under Van Phillips, of an orchestra consisting of star musicians to play well-known light pieces in tasteful style. In "Nicolette" Van Phillips and his All-Star Orchestra offer a delightful surprise, for one of the soloists is Leon Goossens, greatest of oboe players. This is coupled with "Salut d'Amour," featuring Van Phillips' quartet (three oboes and cor anglais!). The number of this record is Columbia FB 1484.

Record-slipping Overcome

THE outstanding feature of interest in Columbia records this month is the new polygonal centre hole (instead of circular) by which record-slipping on the turntable has been overcome. With the present high standard of recording the fractional slip of a record when playing results in a variation of pitch and consequent alteration of tone—a liability specially possible when records be piled on an automatic radiogram. To satisfy themselves that this is effective, Columbia records have been manufactured with this improved centre hole for several months past, so that all current records embody the new patent.

EXCEPTIONAL OFFER for the SEASON!

FAVOURABLE TERMS TO PURCHASERS OF NEW MODELS.
 20% PART EXCHANGE DISCOUNT ON ANY MAKE OF RECEIVER.
 40% ALLOWED ON OLD HYVOLTSTAR MODELS TO READERS OF THIS PAPER.

This splendid offer will enable all to test the superiority of HYVOLTSTAR UNIVERSAL ALL-WAVE ALL MAIN A.C. D.C. RECEIVERS, the individually constructed radio. Models fitted with Ostar-Ganz Universal H.V. Valves. All Models can be had in CHASSIS FORM. Deferred terms suitably arranged. If you are interested in one of our models, have it on approval. Wave-Range 19-2,000 m. 100-250 A.C. D.C. even on 100 D.C. Plants. Write at once for our New Catalogue of our full range of Supers, Radiograms and Amplifiers.

UNIVERSAL HIGH VOLTAGE RADIO LTD., 28/29, Southampton Street, Strand, W.C.2.

Tel.: TEMple Bar 4985, 8608.

NEW PRICES.		
Chassis. Table Model.		
T. Radiogram.		
FOUR VALVE SUPERHET.	12 gns.	15 gns. 19 gns.
SUPERHET FIVE.	13 gns.	17 gns. 20 gns.
SUPERHET SIX.	15 1/2 gns.	19 gns. 24 gns.
SUPERHET SEVEN.	20 1/2 gns.	24 1/2 gns. 29 gns.
SUPERHET EIGHT.	25 gns.	29 1/2 gns. 34 gns.
SUPERHET NINE.	28 gns.	33 gns. 38 gns.
SUPERHET TEN.	30 gns.	35 gns. 40 gns.

- * WE BUILD
- * WE CONVERT
- * WE REPAIR
- * WE EXCHANGE
- * WE GIVE FREE BLUEPRINT

* WE OFFER 20% P.X. ALLOWANCE ON ANY OLD KIT "THE VALVE OF THE FUTURE."



Build from the finest up-to-date CIRCUITS. We offer Universal All-Wave KITS for Supers, Radiograms, Amplifiers and Transmitters, with Free Technical advice. Amazing value, too!
 3-Valve All-Wave Receiver Kit, 19-2,000 m., 25/0/6.
 3-Pentode 4-Valve A.W. Receiver Kit, 20-2,000 m., 22/2/0.
 6-Valve All-Wave Super Kit, 13-2,000 m., 29/2/9.

Amplifier Kits from 23/9/8. S.W. Adapter Kit, 22/14/9. Speakers, 25/-, Radiogram Unit complete with Motor, 4 gns. extra. Generous Hire-Purchase Terms Arranged.

Guaranteed SIX months. EUGEN J. FORBAT, 28/29, Southampton Street, Strand, W.C.2. 'Phone: TEMple Bar 4985, 8608.

EASY TERMS

1936-7 RADIO

FOR MORE THAN TEN YEARS we have SPECIALISED in the supply of all good quality RADIO SETS, COMPONENTS, VALVES and ACCESSORIES. SEND LIST OF YOUR REQUIREMENTS and we will supply keen quotation by return.

W.B. Stentorian Speakers



These splendid Speakers are available on Easy Terms:—
37J Cash price 32/8. or 2/8 with order and 11 monthly payments of 3/-.

CABINET and EXTENSION SPEAKERS on similar terms. FULL LIST ON REQUEST. All well-known L.S. Units supplied on the Lowest Terms.

Valves, etc.

Battery and mains valves, all ring brands supplied on the best terms. Prompt delivery. Please write for quotation for Valves.

★ McCarthy Chassis ★

The remarkable New Model RFGAW ALL-WAVE CHASSIS—Cash price £8/10/-, or delivered for First Payment, £1/7/-, and 10 monthly payments of 18/-—Complete Price List available on request.

Latest Pick-ups and Gramo-motors

All the newest products of well-known Makers supplied on the best of Easy Terms.

'Avomitor' Testing Meter

A most valuable instrument for tracing faults, etc., £2 cash, or 4/- with order, and 10 monthly payments of 4/-.

Eliminators

All well-known makes supplied for FIRST PAYMENT of 5/-.

WE GUARANTEE SATISFACTION TO EVERY CUSTOMER. PROMPT DELIVERY.

CASH or C.O.D. ORDERS SENT BY RETURN.

Estd. 1925 THE LONDON RADIO SUPPLY COMPANY

11 OAT LANE NOBLE STREET LONDON, E.C.2

ELECTRADIX BARGAINS

MICROPHONES. We are makers and carry the largest and most varied stock in London. Prices are low and there are models for all purposes. Our Public Address Bilsel-Reiss Transverse Current Microphones are far superior and all the best judges use them. Only 55/- High-grade Stand as illustrated, 15/- extra.

TABLE MODEL "W.N.11." For Home Broadcasting, containing transformer, switch and plugs; is a marvellous production at a low price. Bakelite square body on bronze base. Worth 2 guineas. Only 15/-. For other models, from 1/- to £10, see list "N."



TELEPHONES. House and Portable Inter-comm. and Telephones of various types cheap. Kindly specify wants. 120 ohm Sullivan Headphones. W.D. model. Aluminium body and headbands. Maker's price to-day, 15/-. Our price, 2/9 per pair. 3d. postage.

THIS BATTERY SUPERSEDER provides H.T. from your L.T. 2-volt battery, rectified and smoothed, 3 tappings. A boon to those who are not on the mains. Reduced from £3 15s. New and Guaranteed, 37/6.



MICRO-AMMETERS for small current. Valve Voltmeters, etc. Sensitivity, 0 to 50 microamps full scale, moving coil, panel type, 2 1/2 in. dial. Reads direct your signal strength on a crystal set. 1,000 ohmores. 50mV. def. Cheap. 40/.

CRYSTAL SETS (for crystal-pure reception). Table type "A," 7/6. Double circuit type "B," 10/6.

WHY NOT LEARN MORSE? Cheap home learner's set, complete with battery and buzzer, on walnut base, 4/6. Large range of Keys, Buzzers, Sounders and Recorders.

1,000 other Bargains in New Sale List "N," Post Free.

ELECTRADIX RADIOS

218, Upper Thames Street, London, E.C.4

Phone: Central 4611

THE BURGHEAD TRANSMITTER

(Continued from page 156)

room in which are terminated the land-lines from Aberdeen. In the control room the programme is passed through amplifiers, which increase the strength to that necessary for the input to the transmitter. There is a programme control position at which the necessary control and switching operations are carried out. There is also a studio for emergency use and for testing, as at other B.B.C. transmitting stations. The apparatus associated with the tuning fork drive is installed in a room in the centre of the upper storey of the office block, facing the transmitter hall.

Reception

The position of the transmitter enables it to provide a satisfactory service all round the coast of the Moray Firth, including Wick and Thurso in the North, owing to the fact that the waves will travel largely over sea. It will not, however, be able to provide an equal service at a similar distance inland owing to the much heavier attenuation. Listeners living near the new station may find it difficult to cut out its transmissions in order to receive distant stations—particularly with unselective receivers. With reasonably modern receivers, however, no serious difficulty is likely to be experienced.

Listeners requiring advice concerning reception are invited to send a postcard to the British Broadcasting Corporation, 5, Queen Street, Edinburgh, or to Broadcasting House, London, W.1, asking for a copy of a pamphlet, entitled "The Burghead Transmitting Station," which will be sent, post free. Applications should be marked "N.S." in the top left-hand corner.

OUR FREE CATALOGUE SERVICE

To save readers trouble we undertake to send on catalogues of any of our advertisers. Merely state, on a postcard, the names of the firms from whom you require catalogues, and address it to "Catalogue," PRACTICAL AND AMATEUR WIRELESS, George Newnes, Ltd., 8-11, Southampton St., Strand, London, W.C.2. Where advertisers make a charge, or require postage, this should be enclosed with applications for catalogues. No other correspondence whatsoever should be enclosed.

CLIX COMPONENTS

WE have received two new folders from Lectrolinx Limited, giving particulars of this firm's small components for the present season. One folder deals with valveholders and connection strips, and includes valveholders of chassis and baseboard mounting types, which are available with and without terminals. A short-wave type valveholder is provided with a low-loss Frequentite base, and is fitted with Clix patent floating sockets. Another type of short-wave valveholder, for baseboard mounting, is fitted with an air-slotted base, the only metal used in its construction being the one-piece tagged sockets. The range of connection strips include the popular two, three and four socket chassis mounting strips complete with terminals. Three and four way voltage selector plates are also listed, a special feature of these plates being that the tappings are so arranged that incorrect insertion is impossible.

In the other folder a range of Clix contact components is given, including plugs, sockets, terminals and connectors. A new component listed is a loudspeaker "plug-switch" control which provides an efficient control for either a set speaker, an extension speaker, or both. It is fitted with a Q.M.B. switch operated by a slight side movement of the plug. The price of the complete control panel is only 1s. 0d. Among the other new components listed is a 5-amp. fuse plug for the protection of a receiver or any domestic electrical appliance. It is fitted with two sensitive fuses of either 1- or 5-amp. ratings, and the price, complete with two fuses, is 1s. 8d.

Newnes' New Weekly!

THE CYCLIST

2d. Every Wednesday.

REPLIES IN BRIEF

The following replies to queries are given in abbreviated form either because of non-compliance with our rules, or because the point raised is not of general interest.

A. E. W. (Burnley). The windings must, of course, be in the same direction. In the event of failure to work, the connections to one set of windings may be reversed.

H. A. (S.E.19). We have no details of the address, etc., here. Write to the American Trade Bureau.

A. R. D. (West Hartlepool). We presume you refer to the B. L. D. L. C. Details of membership, etc., were published in our issue dated August 15th last. Details will be repeated shortly.

D. M. (Bexhill-on-Sea). Write to the Radio Society of Great Britain, Victoria Street, S.W.1.

E. R. N. (Paddington). The idea is quite practicable, but the snag is that as the efficiency of the coupling is increased the risk of instability will arise, especially in a compact set such as a portable. Weight also has to be considered and this generally accounts for the elimination of the coils and condensers.

R. F. B. (Clonmel). The procedure you adopted was quite correct, and either you added insufficient chemical, or it was impure.

R. R. (Salisbury). The valve may be obtained with 7 or 4 pins. If you have obtained a 7-pin valve simply fit a 7-pin base and make the standard connections.

J. B. (Darwen). We are unable to supply diagrams to individual requirements. We have no blueprint of a set of the type indicated by you.

R. H. E. (Worthing). If sufficient interest is shown we shall describe a mains version.

C. D. (Enfield). We no longer include station identification in our Query Service. The remarks you heard indicated that one amateur transmitter was changing over to listen to another, but the call sign of the station is obviously incorrect as there is no identification letter showing the country of origin.

R. J. S. G. (Caerleon). We believe a book on the subject is required by Messrs. Pitman. Write also to the Rothermel Corporation, at Kilburn, who may be able to assist you.

A. W. (Rusholme). The trouble may be caused by the fact that the reaction winding is too close to the grid winding, that the reaction condenser is too large, or that the H.T. applied to the detector valve is too high.

H. H. E. (Chislehurst). The only thing to do would be to use a different type of dial, or rearrange the components. We do not recommend the latter procedure as it may lead to instability. In view of the small height available we advise you to wait for our next receiver.

J. S. F. R. (Liverpool). We cannot give you the information asked for, but we suggest you communicate with the Radio Society of Great Britain, at Victoria Street, S.W.1.

W. F. (Blackpool). Any type of plug-in coil may be used so as to enable the receiver to cover any desired wavelength. An "all-wave" aerial will probably prove best in your case.

S. E. (Garston). It is impossible to solve your problem without a diagram or details of the method of connection adopted for your volume control. Is it a "fader"?

R. A. G. (Herne Hill). Blueprints cannot be sent C.O.D. We have no receiver of the type mentioned by you.

W. H. B. (Wimbledon). The effect you have noticed is quite in order and is simply the equivalent of attaching an aerial or earth to the receiver. We thank you for your notes regarding construction of the cabinet.

S. A. P. (Aldgate). We are afraid we cannot identify your set from the details given. We cannot, therefore, supply a blueprint.

G. T. C. (Penarth). The information has already been given in our pages. The electron stream passes between two pairs of deflecting plates, each pair being at right angles to the other. By applying varying voltages from a time base to each pair of plates the electron beam is drawn both from one side to the other and from top to bottom of the screen. The latter movement is carried out slower than the former movement.

R. B. (Evenwood). We did not design the receiver and have no blueprint. Write to Messrs. Graham Farish, who published details of the receiver.

G. L. J. (Liverpool, 4). The change may be made, but we cannot say whether it will prove better than the specified transformer. The dial is the latest J.B. product, and may be obtained direct from them. The letters M.B. attached to the lead from the volume control through hole 1 are in error. The lead is, of course, attached to the terminal marked I (Input).

R. A. S. (Tredegar). The components are not suitable for inclusion in the Limit All-wave receiver, and we do not recommend the use of them in that set.

N. M. (Liverpool, 13). The 4-pin pentode may certainly be used and should give improved results. The other changes are quite in order and should greatly improve the old receiver.

A. P. (Poole). The amplification should be adequate, but we will endeavour to produce a suitable design during the season, and details will be published as soon as a satisfactory arrangement is found.

C. H. M. D. (March). The only receiver in which we have used the coils is the Add-on Superhet Unit described in our issue dated October 10th, last.

E. M. H. (N.5). The Perfect (P.W. 63) or the Experimenters' Three (P.W. 30A) may be recommended.

QUERIES and ENQUIRIES

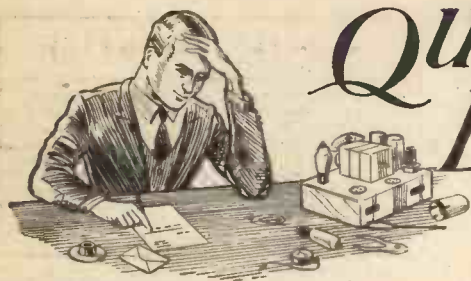

Television Circuits

"Now that television is in regular use I want to start building up a set. Can you supply any circuit details or other information which will be of use to me?"—T. H. (Mill Hill).

WE have a receiver in use and shall publish full details in due course. In the meantime, the mains unit described in last week's issue will no doubt be of use, and the articles which we have already published on sound receivers may also be recommended.

Cathode-ray Tube

"I wish to make up an experimental television receiver, but only require a small tube for experimental purposes as I do not wish to go to the expense of buying a large tube. Is there one on the market with a screen of about 3in. diameter?"—B. R. B. (Clifton).

MESSRS. COSSOR can supply a small cathode-ray tube, but the diameter of the screen is 4½in. The price is £4 15s. We do not think you will be able to obtain a smaller tube than this particular model.

The Limit Four-valver

"Regarding the Limit 4-valver. On the blueprint two extension rods are shown on the reaction condenser and also on the B.T.S. switch. No mention appears to be made of these, and I am wondering if you can give me the necessary details."—D. S. (Birkenhead).

THESE extension rods may be constructed from ordinary ebonite rod, or you may obtain the ready-made Bulgin components. These will be complete with a one-hole fixing bush, enabling them to be mounted in the component-mounting brackets attached to the front of the chassis. The length of the rod is 4in., and the Bulgin reference number is E.H.4. The price is 1s. 6d. each, with the fixing bush.

Short-wave Adapter

"I have built a short-wave adapter as per the enclosed circuit. I am using this coupled to the gramophone pick-up terminals of a commercial all-mains set, but as the adapter requires battery supplies I should like to take all current from the mains set and so do away with all batteries. How can I do this?"—J. G. W. (Dublin).

THE adapter circuit is quite standard except that an L.F. coupling component has been included with a coupling condenser and grid leak. It is thus in order to connect this type of adapter to the

pick-up terminals of a receiver. To use the mains supply of the receiver it would be preferable to dispense with the valve now used in the adapter and to use a mains type valve in its place. Between the valve and the valveholder a special adapter should be connected, and this, in turn, should be wired to a similar adapter inserted between the detector valve in the mains receiver and its valveholder. The provision of the H.T. voltage may occasion some difficulty, and experiments should therefore be made with a view to obtaining a stable output, for which purpose a flexible lead may be attached to the

RULES

We wish to draw the reader's attention to the fact that the Queries Service is intended only for the solution of problems or difficulties arising from the construction of receivers described in our pages, from articles appearing in our pages, or on general wireless matters. We regret that we cannot, for obvious reasons—

- (1) Supply circuit diagrams of complete multi-valve receivers.
- (2) Suggest alterations or modifications of receivers described in our contemporaries.
- (3) Suggest alterations or modifications to commercial receivers.
- (4) Answer queries over the telephone.
- (5) Grant interviews to querists.

Please note also, that queries must be limited to two per reader, and all sketches and drawings which are sent to us should bear the name and address of the sender.

If a postal reply is desired, a stamped addressed envelope must be enclosed. Send your queries to the Editor, PRACTICAL AND AMATEUR WIRELESS, George Newnes, Ltd., 8-11, Southampton Street, Strand, London, W.C.2.

H.T. positive point on the adapter and connected to various points in your mains set. The adapter may be of the type supplied by Messrs. B.T.S. or Bulgin.

Fuse Position

"A fuse is mostly put in the H.T.—lead of the set, but occasionally it is put in the H.T.— and the G.B.+ lead. What are the advantages and disadvantages of each method?"—C. B. (Slaitwaite).

IN certain apparatus, the bias applied to the output valve can be of a very high value, sufficient, in fact, to burn out the valve in the event of the bias voltage being connected across the filament or heater supplies. If the fuse is included only in the H.T. negative lead (to which the G.B. positive connection is made), the protection afforded to the filament wiring is only from a short of the H.T. supply. If, however, the G.B. negative lead should become detached and drop on the positive side of the filament wiring, the grid bias voltage will be applied to the filaments and a burn-out will result. If the G.B. positive lead is attached to the H.T. negative side of the fuse, however, then a short of the above type will also blow the fuse. Some care

will have to be taken, however, in the selection of the fuse for this double purpose, and in many cases it may not be possible to select a value which will give protection from the bias voltage without blowing every time the set is switched on or off, due to H.T. surges.

Charging From D.C. Mains

"I wish to charge my battery from a direct current supply of 110 volts. Could you please give me information regarding the building of a direct current charger? What wattage bulb would be necessary to charge at 2 volts 1 amp.?"—A. R. (Cheltenham).

A LAMP in series with one lead from the mains supply is the only essential, but an on/off switch and protective fuses should also be included. A circuit of a suitable charger is given in our issue dated February 8th last. As you have to drop 108 volts (110—2) at 1 amp. the dropping resistance must be 108 ohms, and the wattage will be 108 watts also. You could use a 100-watt lamp or a carbon filament lamp, and a desirable accessory is an ammeter included in the circuit so as to ensure that the maximum charging rate for the accumulator on charge is not exceeded.

Direction of Current

"I have been delving into the theory of wireless and am rather puzzled by contradictory statements regarding the flow of anode current through a valve. I have read a statement which says that it flows from plate to filament and another saying it flows from filament to plate. I have accepted the latter. Is there any means of detecting the direction of flow? Does current flow from positive to negative or vice-versa? (Poisson's Theory: high potential to low.) Another point is that I understand that the current fluctuates with incoming signals. How, then, can a milliammeter needle remain steady? Is it because the fluctuations either way are infinitesimal and thus unrecorded by the meter?"—D. R. H. (Penrhiwaiber, Glam).

THE problem of current flow is often cropping up, but quite definitely in the valve the flow is from filament to anode, and the inclusion of a galvanometer in the anode circuit will settle the question once and for all. In a voltaic cell or battery there will be a flow from positive to negative to complete the circuit formed by a lamp or other device joined across the battery terminals, and, therefore, in the external circuit the flow is from negative to positive. (H.T. negative is, of course, connected to the filament, and H.T. positive to the anode.) With regard to the changes in anode current, these are so rapid (not so infinitesimal) that the ordinary type of meter cannot follow them.

FREE ADVICE BUREAU COUPON

This coupon is available until October 31st, 1936, and must be attached to all letters containing queries.
PRACTICAL AND AMATEUR WIRELESS,
24/10/36.

THE ONE AERIAL FOR THE MODERN SET

PIX INVISIBLE AERIAL

PIX LONDON S.E.1

Highly efficient, self adhesive aluminium strip—gives wonderful pick-up clear of interference—fixed in a jiffy without tools—just press it and it sticks.



2/-

Double Length 3/6

Practical and Amateur Wireless BLUEPRINT SERVICE

PRACTICAL WIRELESS STRAIGHT SETS. Battery Operated.		
One-valve : Blueprint, 1s. each.	Date of Issue.	No. of Blueprint
All-wave Unipen (Pentode)		PW31A
Two-valve : Blueprints, 1s. each.		
Four-range Super Mag Two (D, Pen)	11.8.34	PW36B
Three-valve : Blueprints, 1s. each.		
Selectone Battery Three (D, 2 LF (Trans))		PW10
Sixty-Shilling Three (D, 2 LF (RC & Trans))	2.12.33	PW34A
Leader Three (SG, D, Pow)		PW35
Summit Three (HF Pen, D, Pen)	8.8.34	PW37
All Pentode Three (HF Pen, D (Pen), Pen)	22.9.34	PW39
Hall-Mark Three (SG, D, Pow)		PW41
Hall-Mark Cadet (D, LF, Pen (RC))	10.3.35	PW48
F. J. Camm's Silver Souvenir (HF Pen, D (Pen), Pen) (All-Wave Three)	13.4.35	PW49
Genet Midget (D, 2 LF (Trans))	June '35	PM2
Cameo Midget Three (D, 2 LF (Trans))	8.6.35	PW51
1936 Sonotone Three-Four (HF Pen, HF Pen, Westector, Pen)	17.8.35	PW53
Battery All-Wave Three (D, 2 LF (RC))	31.8.35	PW55
The Monitor (HF Pen, D, Pen)	8.2.36	PW61
The Tutor Three (HF Pen, D, Pen)	21.3.36	PW62
The Centaur Three (SG, D, P)		PW64
The Gladiator All-Wave Three	29.8.36	PW66
Four-valve : Blueprints, 1s. each.		
Fury Four (2 SG, D, Pen)		PW11
Beta Universal Four (SG, D, LF, Cl. B)	15.4.33	PW17
Nucleon Class B Four (SG, D (SG), LF, Cl. B)	6.1.34	PW34B
Fury Four Super (SG, SG, D, Pen)		PW34C
Battery Hall-Mark 4 (HF Pen, D, Push-Pull)		PW46
F. J. Camm's "Limit" All-Wave Four (HF Pen, D, LF, P)	26.9.36	PW67
Mains Operated.		
Two-valve : Blueprints, 1s. each.		
A.C. Twin (D (Pen), Pen)		PW18
A.C. D.C. Two (SG, Pow)	7.10.33	PW31
Selectone A.C. Radiogram Two (D, Pow)		PW19
Three-valve : Blueprints, 1s. each.		
Double-Diode-Triode Three (HF Pen, DDT, Pen)	10.6.33	PW23
D.C. Ace (SG, D, Pen)	15.7.33	PW25
A.C. Three (SG, D, Pen)		PW29
A.C. Leader (HF Pen, D, Pow)	7.4.34	PW35C
D.C. Premier (HF Pen, D, Pen)	31.3.34	PW35B
Ubique (HF Pen, D (Pen), Pen)	28.7.34	PW36A
Armada Mains Three (HF Pen, D, Pen)	18.8.34	PW38
F. J. Camm's A.C. All-Wave Silver Souvenir Three (HF Pen, D, Pen)	11.5.35	PW50
"All-Wave" A.C. Three (D, 2 LF (RC))	17.8.35	PW54
A.C. 1936 Sonotone (HF Pen, HF Pen, Westector, Pen)	31.8.35	PW56
Four-valve : Blueprints, 1s. each.		
A.C. Fury Four (SG, SG, D, Pen)		PW20
A.C. Fury Four Super (SG, SG, D, Pen)		PW34D
A.C. Hall-Mark (HF Pen, D, Push-Pull)		PW45
Universal Hall-Mark (HF, Pen, D, Push-Pull)	9.2.35	PW47
SUPERHETS.		
Battery Sets : Blueprints, 1s. each.		
£5 Superhet (Three-valve)		PW40
F. J. Camm's 2-valve Superhet (Two-valve)	13.7.35	PW52
F. J. Camm's £4 Superhet		PW58
Mains Sets : Blueprints, 1s. each.		
A.C. £5 Superhet (Three-valve)		PW43
D.C. £5 Superhet (Three-valve)	1.12.34	PW42
Universal £5 Superhet (Three-valve)		PW44
F. J. Camm's A.C. £4 Superhet 4		PW59
F. J. Camm's Universal £4 Superhet 4	11.1.36	PW60
SHORT-WAVE SETS.		
Two-valve : Blueprints, 1s. each.		
Midget Short-Wave Two (D, Pen)	15.9.34	PW38A
Three-valve : Blueprints, 1s. each.		
Experimenter's Short-Wave Three (SG, D, Pow)		PW30A
The Prefect 3 (D, 2 LF (RC and Trans))	8.2.36	PW63
The Bandsread S.W. Three (HF Pen, D (Pen), Pen)	5-12-33	PW68

PORTABLES.		
Three-valve : Blueprints, 1s. each.		
F. J. Camm's ELF Three-valve Portable (HF Pen, D, Pen)	16.5.36	PW65
Four-valve : Blueprints, 1s. each.		
Featherweight-Portable Four (SG, D, LF, Cl. B)		PW12
MISCELLANEOUS.		
S.W. Converter-Adapter (1 valve)		PW48A
AMATEUR WIRELESS AND WIRELESS MAGAZINE CRYSTAL SETS.		
Blueprints, 6d. each.		
Four-station Crystal Set		AW427
1934 Crystal Set		AW444
150-mile Crystal Set		AW450
STRAIGHT SETS. Battery Operated.		
One-valve : Blueprints, 1s. each.		
B.B.C. Special One-valver		AW387
Twenty-station Loud-speaker One-valver (Class B)		AW449
Two-valve : Blueprints, 1s. each.		
Melody Ranger Two (D, Trans)		AW388
Full-volume Two (SG det, Pen)		AW392
B.B.C. National Two with Lucerne Coil (D, Trans)		AW377A
Big-power Melody Two with Lucerne Coil (SG, Trans)		AW328A
Lucerne Minor (D, Pen)		AW425
A Modern Two-valver	July '36	WM409
Three-valve : Blueprints, 1s. each.		
Class-B Three (D, Trans, Class B)	22.4.33	AW386
New Britain's Favourite Three (D, Trans, Class B)	15.7.33	AW394
Home-Built Coil Three (SG, D, Trans)		AW404
Fan and Family Three (D, Trans, Class B)	25.11.33	AW410
£5 5s. S.G.3 (SG, D, Trans)	2.12.33	AW412
1934 Ether Searcher : Baseboard Model (SG, D, Pen)	20.1.34	AW417
1934 Ether Searcher : Chassis Model (SG, D, Pen)		AW419
Lucerne Ranger (SG, D, Trans)		AW422
Coscor Melody Maker with Lucerne Coils		AW423
Mullard Master Three with Lucerne Coils		AW424
£5 5s. Three : De Luxe Version (SG, D, Trans)	19.5.34	AW435
Lucerne Straight Three (D, RC, Trans)		AW437
All Britain Three (HF Pen, D, Pen) "Wireless League" Three (HF Pen, D, Pen)		AW448
Transportable Three (SG, D, Pen)	3.11.34	AW451
£6 6s. Radiogram (D, RC, Trans)		WM271
Simple-tune Three (SG, D, Pen)	June '33	WM318
Economy-pentode Three (SG, D, Pen)	Oct. '33	WM327
"W.M." 1934 Standard Three (SG, D, Pen)		WM337
£3 3s. Three (SG, D, Trans)	Mar. '34	WM351
Iron-core Band-pass Three (SG, D, QP 21)	June '34	WM354
1935 £6 6s. Battery Three (SG, D, Pen)		WM362
PTP Three (Pen, D, Pen)	June '35	WM371
Certainty Three (SG, D, Pen)	Sept. '35	WM389
Minutube Three (SG, D, Trans)	Oct. '35	WM396
All-wave Winning Three (SG, D, Pen)	Dec. '35	WM400
Four-valve : Blueprints, 1s. 6d. each.		
65/- Four (SG, D, RC, Trans)		AW370
"A.W." Ideal Four (2SG, D, Pen)	16.9.33	AW402
2 H.F. Four (2SG, D, Pen)		AW421
Crusaders' A.V.C. 4 (2HF, D, QP21)	18.8.34	AW445
(Pentode and Class-B Outputs for above : blueprints, 6d. each)	25.8.34	AW454A
Self-contained Four (SG, D, LF, Class B)	Aug. '33	WM331
Lucerne Straight Four (SG, D, LF, Trans)		WM350
£5 5s. Battery Four (HF, D, 2 LF)	Feb. '35	WM381
The H.K. Four (HF Pen, HF Pen, D, Pen)	Mar. '35	WM384
The Auto Straight Four (HF Pen, HF Pen, DDT, Pen)	April '36	WM404
Five-valve : Blueprints, 1s. 6d. each.		
Super-quality Five (2 HF, D, RC, Trans)	May '33	WM329
New Class-B Five (2 SG, D, LF, Class B)	Nov. '33	WM340
Class-B Quadradyne (2 SG, D, LF, Class B)	Dec. '33	WM344
Mains Operated.		
Two-valve : Blueprints, 1s. each.		
Consoelectric Two (D, Pen) A.C.	23.9.31	AW403
Economy A.C. Two (D, Trans) A.C.		WM286
Unicorn A.C./D.C. Two (D, Pen)	Sept. '35	WM394

These blueprints are full size. Copies of appropriate issues containing descriptions of these sets can in most cases be obtained as follows:— "Practical Wireless" at 4d., "Amateur Wireless" at 4d., "Practical Mechanics" at 73d., and "Wireless Magazine" at 1/3d., post paid. Index letters "P.W." refer to "Practical Wireless" sets, "P.M." to "Practical Mechanics" sets, "A.W." refer to "Amateur Wireless" sets, and "W.M." to "Wireless Magazine" sets. Send (preferably) a postal order (stamps over sixpence unacceptable) to "Practical and Amateur Wireless" Blueprint Dept., Geo. Newnes, Ltd., 8-11, Southampton Street, Strand, W.C.2.

Three-valve : Blueprints, 1s. each.		
Home-lover's New All-electric Three (SG, D, Trans) A.C.		AW383
S.G. Three (SG, D, Pen) A.C.		AW390
A.C. Triodyne (SG, D, Pen) A.C.	19.8.33	AW399
A.C. Pentaquester (HF Pen, D, Pen) A.C.	23.6.34	AW436
Mantovani A.C. Three (HF, Pen, D, Pen) A.C.		WM374
£15 15s. 1936 A.C. Radiogram (HF, D, Pen)	Jan. '36	WM401
Four-valve : Blueprints, 1s. 6d. each.		
All Metal Four (2 SG, D, Pen)	July '33	WM326
Harris Jubilee Radiogram (HF Pen, D, LF, P)	May '35	WM386
SUPERHETS.		
Battery Sets : Blueprints, 1s. 6d. each.		
Modern Super Senior		WM375
Varsity Four	Oct. '35	WM395
The Request All-Waver	June '36	WM407
1935 Super Five Battery (Super-hot)		WM379
Mains Sets : Blueprints, 1s. 6d. each.		
1934 A.C. Century Super A.C.		AW425
Heptode Super Three A.C.	May '34	WM359
"W.M." Radiogram Super A.C.		WM346
1935 A.C. Stenode	Apr. '35	WM385
PORTABLES.		
Four-valve : Blueprints, 1s. 6d. each.		
Midget Class B Portable (SG, D, LF, Class B)	20.5.33	AW380
Holiday Portable (SG, D, LF, Class B)	1.7.33	AW393
Family Portable (HF, D, RC, Trans)	22.9.34	AW447
TWO H.F. Portable (2 SG, D, QP21)	June '34	WM363
Tyers Portable (SG, D, 2 Trans)		WM367
SHORT-WAVE SETS—Battery Operated.		
One-valve : Blueprints, 1s. each.		
S.W. One-valve converter (Price 6d.)		AW329
S.W. One-valve for America		AW420
Roma Short-waver		AW452
Two-valve : Blueprints, 1s. each.		
Ultra-short Battery Two (SG det, Pen)	Feb. '36	WM402
Home-made Coil Two (D, Pen)		AW440
Three-valve : Blueprints, 1s. each.		
World-ranger Short-wave 3 (D, RC, Trans)		AW355
Experimenter's 5-metre Set (D, Trans. Super-regen)	30.6.34	AW438
Experimenter's Short-waver (SG, D, Pen)	Jan. 10, '35	AW463
The Carrier Short-waver (SG, D, P.)	July '35	WM399
Four-valve : Blueprints, 1s. 6d. each.		
A.W. Short-wave World Beater (HF Pen, D, RC, Trans)		AW436
Empire Short-waver (SG, D, RC, Trans)		WM313
Standard Four-valve Short-waver (SG, D, LF, P)	Mar. '35	WM358
Superhet : Blueprint, 1s. 6d.		
Simplified Short-wave Super	Nov. '35	WM357
Mains Operated.		
Two-valve : Blueprints, 1s. each.		
Two-valve Mains short-waver (D, Pen) A.C.		AW453
"W.M." Band-spread Short-waver (D, Pen) A.C./D.C.		WM368
"W.M." Long-wave Converter		WM380
Three-valve : Blueprint, 1s.		
Emigrator (SG, D, Pen) A.C.		WM352
Four-valve : Blueprint, 1s. 6d.		
Standard Four-valve A.C. Short-waver (SG, D, RC, Trans)	Aug. '35	WM391
MISCELLANEOUS.		
Enthusiast's Power Amplifier (1/6)	June '35	WM38
Listener's 5-watt A.C. Amplifier (1/6)	Sept. '35	WM392
Radio Unit (2v.) for WM392 (1s.)	Nov. '35	WM398
Harris Electrogram (battery amplifier) (1/-)	Dec. '35	WM399
De-Luxe Concert A.C. Electrogram	Mar. '36	WM403
New style Short-waver Adapter (1s.)	June '35	WM388
Trickle Charger (6d.)	Jan. 5, '35	AW426
Short-wave Adapter (1s.)	Dec. 1, '34	AW456
Superhet Converter (1s.)	Dec. 1, '34	AW457
B.L.D. L.C. Short-Wave Converter (1s.)	May '36	WM405
Wilson Tone Master (1s.)	June '36	WM406
The W.M. A.C. Short-Wave Converter (1s.)	July '36	WM408

Miscellaneous Advertisements

Advertisements are accepted for these columns at the rate of 3d. per word. Words in black face and/or capitals are charged double this rate (minimum charge 3/- per paragraph). Display lines are charged at 6/- per line. All advertisements must be prepaid. All communications should be addressed to the Advertisement Manager, "Practical and Amateur Wireless," 8, Southampton Street, Strand, London.

RECEIVERS, COMPONENTS AND ACCESSORIES

Surplus, Clearance or Secondhand, etc.

RADIOMART SHORT-WAVE SPECIALISTS

Announce 1937

SHORT-WAVE MANUAL

Packed with short-wave information and circuits of mains and battery receivers, including straight, superhet and 5-metre transmitters, modulators, etc. Information on transmitting licences, aeriels, Class B amplification, neutralization, superhet alignment, etc. The most comprehensive manual published, written by practical engineers, price 6d., post free 7 1/2d., including catalogue.

1937 Catalogue only (3 times enlarged) price 1 1/2d. post free.

COSSOR 1936. Superferrodyne receivers half price £2/19/6. Stamp for full list.

TELESEN screened dual range coils, 2/6. Pair 4/6. Milliammeters, 25ma. upwards, 5/9. Super, 6/9. AMERICAN mains transformers 230 v. fully shrouded, 350/350. 6.3v., 5v., 6/11. Majestic 250/250. 2.5v., 5v., 4/11.

HEAVY DUTY mains transformer worth 35/- 350/350. 150 ma.; 4v.2.5ACT., 4v6ACT., 12/6. KC/S., IF, transformers, 2/11. Telsen Ace. 1/11. RG4, Radiogrand, 2/9. 2mf. 300v. 9d. UTILITY straight line wavelength dials, 3/11. Telsen H.F. chokes, 1/11.

UTILITY 2-gang inknob and dial, 3/11; 1,500-volt tubular condensers, all sizes, 6d. ELECTROLYTICS 500-volt 8mf. 1/6; 4mf. 1/6; 4 x 4 1/11; 8 x 8 3/6; 25mf. 25v. 1/-, etc. SMOOTHING chokes, 20 hy. 120 m.a., 3/11; 100 m.a., 2/11; 40 m.a., 1/11.

PUSHBACK wire, 6 yds. 6d.; heavy 9d.; 2 gross solder tags, 6d.; resin-cored solder, 9ft. 6d. CENTRALAB pots, all sizes; 1/6; switched, 2/-; tubular glass fuses, 2d.

JENSON PM speakers, 12/6. Varley Iron Core coils, 2/6; matched pair 4/6.

SPECIAL OFFER Class B valve, driver transformer and valveholder, new, lot 5/-. ISSEN 3-gang bandpass, 3-gang superhet, 2-gang allwave coils, any set, price 7/6.

TRADERS' monster bargain parcels, value £4/10/-, for 10/-; also 5/- parcels. FAMOUS Continental A.C. valves, 4/6; American Duotron, etc., all types, 3/6; battery from 2/3.

UTILITY 8/6, microdisc dials, 3/11; Radiophone, 0.00016 short-wave condensers, 3/6; series gap, twin, 3/9. CERAMIC all brass microvariables, 15 mmfd., 1/4; 40 mmfd. 1/7; 100 mmfd., 1/10; short wave H.F.C., 9d.

CLEARANCE catalogue 11d. Goods over 5/- post free. All enquirers must send stamp. Branches: 19, John Bright St., 44, Dale End. Mail orders, 44, Holloway Head, Birmingham. Telephone, MID 3254.

CONVERSION UNITS for operating D.C. Receivers from A.C. Mains, improved type, 120 watts output, at £2/10/0. Send for our comprehensive list of speakers. Resistances and other components. WARD, 46, Farringdon Street, London, E.C.4. Telephone: Holborn 9703.

ALCO ELIMINATORS AND CHARGERS.—3-5 H.T. taps. 120-150 v., 20-30 ma., 20/-; With 1/2 amp. charger, 26/-; With 1/2 amp. charger, 30/-. Charger alone, 12/-. Year's guarantee. Details free. P. & D. RADIO, 1, Gooding Road, N.7.

WE BUY for cash, all types of Modern Second-hand Radio Sets, Accessories, etc. Unbeatable Part-exchange allowances for new goods. Bring, send or write.

UNIVERSITY RADIO LTD., 82, Hampstead Road, London, N.W.1. Phone: Euston 3810.

LOUDSPEAKER REPAIRS

REPAIRS to Moving Coil Speakers, Cones and Coils fitted or rewound. Fields altered. Prices Quoted including Eliminators, Loud-speakers Repaired, 4/-. L.F. and Speech Transformers, 4/- post free. Trade invited. Guaranteed. Satisfaction. Prompt Service. Estimates free. I. S. Repair Service, 6, Balham Grove, London, S.W.12. Battersea 1321.

PREMIER SUPPLY STORES

THE LARGEST RADIO MAIL ORDER HOUSE IN THE EMPIRE

Offer the following Manufacturers' Brand New Surplus Goods at a Fraction of the Original Cost; all goods guaranteed perfect; carriage paid over 5/-; under 5/- postage 6d. extra. Orders under 5/- cannot be sent C.O.D.

SHORT-WAVE COILS, 4- and 6-pin types, 13-26, 22-47, 41-94, 78-170 metres, 1/9 each, with circuit. Special set of 3 S.W. Coils, 14-150 metres, 4/- set, with circuit. Premier 3-band S.W. Coil, 11-25, 19-43, 38-86 metres. Simplifies S.W. receiver construction, suitable any type circuit, 2/-.

COIL FORMERS, in finest plastic material, 1 1/2 in. low-loss ribbed, 4- or 6-pin, 1/- each. SUPER CERAMIC CONDENSERS, S.L.F. .00016, .0001, 2/9 each; double-spaced, .00005, .000025, .00015 3/- each. All brass with integral slow motion, .00015 tuning, 3/9; .00015 reaction, 2/9. British Radiophone 2-gang, .00016 with trimmers, 5/6.

MAINS VALVES, famous Europa 4 v. A.C. types, 4/6 each. H.L. L., S.G. Var.-Mu-H.F. P.C.S., Var.-Mu-H.F. P.C.S., 1; 3 and 4-watt A.C. directly-heated output Pentodes. Full-wave rectifiers, 250 v. 60 m.a. A.C./D.C. types. 20-volt. 18 amp. S.G. Var.-Mu-S.G. H. HL., Power. Following Types, all 5/6 each. Full-wave rectifiers, 350 v. 120 m.a. and 500 v. 120 m.a. 2 1/2 watt indirectly-heated Pentodes. Frequency Changers, Octodes and Heptodes.

BATTERY VALVES, 2 volts, H.F. L.F., 2/3. Power, Super-Power, 2/9. S.G. Var.-Mu-S.G., 4- or 5-pin Pentodes, H.F. P.C.S. V.-Mu-H.F. P.C.S., 5/- Class B, 3/6.

AMERICAN VALVES. Genuine American HYTRON first-grade Valves, 3 months' guarantee. All the following types: 1A6, 1C6, 2A3, 2A5, 2A6, 2A7, 2B7, 6A4, 6A7, 6B7, 6C6, 6D6, 6F7, 00A, 01A, 11, 12, 15, 18, 19, 20, 22, 24A, 26, 27, 30, 31, 32, 33, 34, 35, 36, 37, 38, 39/44, 40, 41, 42, 43, 45, 46, 47, 48, 51, 53, 55, 56, 57, 58, 59, 71A, 75, 76, 77, 78, 79, 80, 81, 82, 83, 84, 85, 89, V99, X99, 112A, 1V0, 5Z3, 12Z3, 25Y5, 25Z5, 6A6, 6B5, 185R, 5/6 each. 210 and 250, 8/6 each. New Metal-glass Valves, all types, 6/6 each. Genuine American DUOTRON Valves, all types, 3/6 each.

VALVE HOLDERS for all above types, 6d. each. Octal Bases, 9d. each.

SHORT-WAVE KIT for 1-valve receiver or adaptor, complete with chassis, 4 coils, 14-150 metres, condensers, circuit and all parts, 12/6. VALVE GIVEN FREE! DELUXE MODEL, 17/6. SUPERHET CONVERTER KIT, 13/6. 2-VALVE S.W. KIT, 19/6. VALVES GIVEN FREE! 3-VALVE S.W. KIT, S.G. Det. and Pen., 42/- VALVES GIVEN FREE!

ALL-WAVE "ALL-WORLD RANGE" 3-valve Kit, 12-2,000 metres in 4 wavebands without coil changing, complete kit of parts with 3 valves, S.G.H.F., S.G. Det. and Pentode (2 volts), 50/- P.P.P. Model, 6/6 extra.

BAND-PASS TUNING PACK, comprising set of Telsen 3-gang iron-cored coils with integral switching, mounted on steel chassis with 3-gang condenser, illuminated disc-drive and 4 valveholders. 25/- the lot. All Mains or Battery circuit. FREE!

ISSEN ALL-WAVE COILS, 12-2,000 metres, complete with switching and wiring diagram, 12/6. 3-WATT A.C. AMPLIFIER, 2-stage for mike or pick-up, complete kit of parts with 3 valves, 40/- SPECIAL OFFER! 12/6 P.M. Speaker, 35/- Transverse Current Mike, complete with transformer and 7/6 Stand. If purchased with above kit, 25/- the lot.

7-WATT A.C./D.C. AMPLIFIER, 3-stage, high-gain, push-pull output. Complete kit of parts with 5 specially matched valves, £4 4s. SPECIAL OFFER! 21/- pair Matched Speakers, 35/- Transverse Current Mike, complete with transformer and 7/6 stand. If purchased with above kit, 35/- the lot.

10-WATT 3-Stage A.C. Amplifier Kit with 5 valves, £5 5s. SPECIAL OFFER! 21/- pair Matched Speakers, 35/- Transverse Current Mike, complete with transformer and 7/6 stand. If purchased with above kit, 35/- the lot.

20-WATT 3 stage A.C. Amplifier Kit with 5 valves, £8 8s. SPECIAL OFFER! £6 pair P.M. Exponential Horn Speakers, 35/- Transverse Current Mike with transformer and 7/6 stand. If purchased with above kit, £5 10s. the lot.

MAGNAVOX, Mains energized. '154', 7in. cone, 2,500 ohms 4 watts, 12/6; '152', 9in. cone, 2,500 ohms, 17/6; '152 Magna', 9in. cone, 2,500 ohms, 6 watts, 37/6. Magnavox P.M.'s—'154', 7in. cone, 16/6; '252', 9in. cone, 22/6. Reliable P.M.'s, 10/6; Cossor P.M.'s, 13/6.

ROLA latest type P.M.'s, 18/6. KB 7in. mains energized, 1,500 or 2,500 ohms, 7/9. GOODMAN'S Sin. mains energized, 1,000 ohms field, 10/6 each.

DIALS—Clarion Illuminated S.W. slow-motion Dial with 2in. knob, 2/-; Premier All-Wave 2-speed Dial, full vision straight-line, dual ratios 10-1 and 150-1, 6/6, with escutcheon.

POTENTIOMETERS by well-known makers. All values up to 1 meg., 2/-; with switch, 2/6. PREMIER (Reisz Pattern) Transverse-current MIKE, High Output, Straight Line Response, 30/-; Transformer, 5/-; Table Stand, 7/6.

PREMIER wire-end type with screened primaries, and tapped 200-250 v. Centre-tapped Filaments Guaranteed one year. H.T. 8 & 9 or H.T. 10 with 4 v. 4 a. C.T. and 4 v. 1 a. C.T., 8/6. 250-250 v. 60 m.a., 4 v. 1 a., 4 v. 2 a. and 4 v. 4 a., all C.T., 8/6. 350-350 v. 120 m.a., 4 v. 1 a., 4 v. 2 a. and 4 v. 4 a., all C.T., 10/6. Any of these transformers with engraved panel and N.P. terminals, 1/6 extra. 500-500 v. 150 m.a., 4 v. 2-3 a., 4 v. 2-3 a., 4 v. 2-3 a., 4 v. 3-4 a., all C.T., 19/6. AUTO TRANSFORMERS, step up or down, 60 watts, 7/6; 100 watts, 10/-.

SMOOTHING CHOKES, 25 m.a., 2/9; 40 m.a., 4/-; 60 m.a., 5/6; 150 m.a., 10/6. 2,500 ohms, 60 m.a. Speaker Replacement Chokes, 5/6.

MILLIAMMETERS, moving-iron, flush 2 1/2 in., all ranges from 0-10, 5/9. Visual tuning, 6 or 12 m.a., 5/9; Moving-coil meters, 2 1/2 in. 0-1 m.a., 18/6; 3 1/2 in. 0-1 m.a., 22/6. Multipliers, 1/- each.

ELECTROLYTICS. U.S.A. 4, 8 or 12 mfd. 530 v. peak, 1/9 each. Duibiler, 4 or 8 mfd. 500 v. 3/-; 50 mfd. 50 v., 1/9; 12 mfd. 20 v. 6d.; 25 mfd. 25 v., 1/-; T.C.C. 4 or 8 mfd. 650 v., 4/-; 15 mfd. 50 or 100 v., 1/-; 50 mfd. 12 v., 1/-; Paper Condensers. W. E. 250 v. working 4 mf. 2/-; 2 mf. 1/-, 1 mf. 6d.; 350v. working 4 mf. 4/-; 800 v. 4 mf. 6/-; Duibiler 500 v. working 4 mf. 4/-; 800 v. 4 mf. 6/-; Wego 450 v. working 1 mf. 1/-, 2 mf. 1/9, 4 mf. 3/-; 700 v. working 2 mf. 2/-, 4 mf. 3/6.

TRANSFORMERS, latest type Telsen R.G.4 (list 12/6), 2/9. Lissen Hypernik Q.P.P. (list 12/6), 3/6.

ELIMINATOR KITS for A.C. mains. 120 v. 20 m.a., or 150 v. 25 m.a., 10/-, tapped S.G. det. and output. Complete Kit with long life valve rectifier (replacement cost only 2/-).

High-grade POWER PACKS by prominent makers. Input 100-250 v. A.C. Output 220 v. at 40 m.a., 4 v. 3 a. C.T. Complete with valve rectifier, 18/6.

PREMIER L.T. CHARGER KITS for A.C. mains, including Westinghouse Rectifiers and Tapped Mains Transformers. 8 volts at 1/2 amp., 14/6; 8 volts 1 a., 17/6; 15 volts 1 a., 19/-; 15+15 volts 1 a., 37/6; 15+15+15 volts 1 a., 50/-; 8 volts 2 a., 29/6.

Telsen Iron cored screened coils, W.349, 4/- each. Electric SOLDERING IRONS, 200-250 v., A.C./D.C., 2/3.

GRAMOPHONE MOTORS, Collaro Gramophone Unit consisting of A.C. motor, 100-250 v. high quality pick-up and volume control, 45/-; Collaro motor only, 30/-; Collaro Universal Gramophone Motor, 100-250 v. A.C./D.C., with high quality pick-up and volume control, 67/6; Collaro Universal Motor only, 49/6; Edison Bell double-spring motors, including turntable and all fittings, 15/-; Cosmocord Gramo unit, comprising A.C. motor pick-up and volume control (list 55/-), 35/9.

COSMOCORD Pick-up with Tonearm and Vol. Control, 10/6. Pick-up head only, 4/6.

TUBULAR CONDENSERS, non-inductive, all values up to 5 mfd., 6d. each.

WIRE-END RESISTORS, any value, 1 watt, 6d.; 4 watts, 1/-; 8 watts, 1/6; 15 watts, 2/-; 25 watts, 2/6 each.

RELIABLE MORSE KEYS with Morse Code engraved on bakelite base, 2/- each.

BAKELITE case BUZZERS, 1/6; "Loud-tone," 2/6 each.

SUPER Quality lightweight HEADPHONES, 3/9 pair.

RECEIVERS, G.E.C., A.C./D.C. mains, 3-valve sets, complete with 3 Osram valves, in exquisite bakelite cabinet with Osram M.C. speaker, ready to plug in to any mains, brand new, in sealed cartons, fully guaranteed (list £7 15s.), 69/6. Carriage paid.

G.E.C. Compact 3-valve Battery Sets complete with 3 Osram valves, moving coil P.M. Speaker in attractive Bakelite cabinet, makers' 1936 series in original sealed carton, 50/- (list £5/10/0).

H.F. CHOKES. S.W. 10-200 metres, 9d.; S.W. screened, 1/6; standard screened 180-2,000 metres, 1/6.

ALL POST ORDERS TO JUBILEE WORKS, 167, LOWER CLAPTON RD, LONDON, E.5 CALLERS, AS USUAL, TO 20-22, HIGH ST., CLAPHAM, S.W.4. (Macauley 2381) Phone: Amherst 4723 And 165 & 165A FLEET ST., E.C.4. (Next door to Anderton's Hotel). Central 2833.

HAVE YOU HAD OUR LATEST GIANT ILLUSTRATED CATALOGUE AND VALVE LIST? IF NOT SEND 4d. IN STAMPS FOR THIS AMAZING LIST OF BARGAINS!

RADIO CLEARANCE

63, HIGH HOLBORN, W.C.1.

TEL.: HOLBORN 4631

The Mail Order House with the World Wide Reputation; quality goods and satisfaction assured.

Price £8.19.6 PLESSEY 6-VALVE, ALL-WAVE A.C. RECEIVER, wave range 15-2,000 metres. 9in. Auditorium Speaker, provision for external speaker and pick-up, handsome walnut cabinet of modern design, brand new, made for export: to sell at 20 gns.

50/- LISSEN BAND PASS 3 KIT, sealed, with valves.

EXCLUSIVE BRITISH RIGHTS held by us for Constructrad Short Wave Kits, all kits supplied, valves free. 5 interchangeable coils, covering a range from 15-600 metres; complete set, not a converter.

29/6 1 VALVE BATTERY KIT.

37/6 2 VALVE BATTERY KIT.

37/6 1 VALVE A.C./D.C. KIT.

49/6 2 VALVE A.C./D.C. KIT.

£5.19.6 EVER-READY 5 VALVE BATTERY S.H. incorporating A.V.C., large square type dial, provision for pick-up, and extension speaker, listed 12 gns., stocks are limited, order at once to avoid disappointment.

39/6 LISSEN 4 VALVE A.C. RECEIVER, complete with valves, P.M. M.C. Speaker, Handsome horizontal cabinet, S.G. det., pen., rectifier.

70/- LISSEN 4 VALVE A.C. BAND PASS RECEIVER, a quality job, listed at £9 15s., sent out, aerial tested, complete with valves.

55/- LISSEN BAND PASS BATTERY RECEIVER, complete with valves.

35/- LISSEN 3 VALVE PLUS BARRETA D.C. RECEIVER, fitted handsome horizontal walnut cabinet, complete with valves.

75/- A.C./D.C. AMERICAN MIDGET, 5 valve type, a real quality job, Jensen Moving Coil Speaker, etc., brand new, boxed.

BRUCE MAINS TRANSFORMERS AND CHOKES, standard for the season, finest made, British and guaranteed.

8/6 250-0-250, 80 m.a., 2-0-2 volts 2.5 amp., 2-0-2 volts 4 amp.

10/6 350-0-350, 120 m.a., 2-0-2 volts 2.5 amp., 2-0-2 volts 4 amp.

12/6 350-0-350, 150 m.a., 2-0-2 volts 2.5 amp., 2-0-2 volts 4 amp., 2-0-2 volts 2 amp.

17/6 500-0-500, 150 m.a., 2-0-2 volts 2.5 amp., 2-0-2 volts 6 amp., 2-0-2 volts 2 amp., 2-0-2 volts 2 amp.

8/6 H.T.3 TRANSFORMER, 250 volts, 60 m.a., 2-0-2 volts, 4 amp.

17/6 ditto with H.T.5 metal rectifier.

ALL TRANSFORMERS ARE FULLY SHROUDED.

MAINS CHOKES.

4/6 40 m.a. 30 Hys.

6/- 60 m.a. 40 Hys.

10/6 150 m.a. 40 Hys.

21/- 250 m.a. 15 Hys.

6/- 60 m.a. 80 Hys. 2,500 ohms for speaker replacement, etc.

12/6 SPECIAL CLEARANCE CHOKES, 250 m.a. 12 Hys., 100 ohms heavy duty type interleaved windings, etc., cannot be repeated.

TRIAD AMERICAN VALVES, highest quality. All types 5/6 each, as follows: 01A, 24A, 27, 30, 31, 32, 33, 35, 37, 38, 39, 41, 43, 45, 46, 47, 53, 55, 56, 57, 58, 59, 71A, 75, 78, 80, 6A6, 1C6, 6F7, 2A3, 5Z3, 12A7, 8A7, 6C6, 6D6, 12Y3, 25Z5.

All these Valves carry a 90 day guarantee and Free Replacement provided that the filament or heater is intact, and the glass is not broken when returned to us.

3/6 Lissen Class B. Valves, brand new, boxed.

2/6 8 mfd. and 4 mfd. electrolytics, 450 volt working, 500 volt peak, well-known make.

6d. 1 WATT WIRE END RESISTANCES, well-known make, all values.

1/- 50 mfd., 12 VOLT WORKING CONDENSERS, well-known manufacture.

1/3 50 mfd., 25 VOLT WORKING CONDENSERS, well-known manufacture.

1/6 50 mfd., 50 VOLT WORKING CONDENSERS, well-known manufacture.

1/- 25 mfd., 50 VOLT WORKING CONDENSERS, well-known manufacture.

3/11 8+8+4 ELECTROLYTIC CONDENSERS (cardboard), wire ends. 450v. working.

1/11 6+6 450 VOLT WORKING, ELECTROLYTIC CONDENSERS, metal case, wire ends, by well-known manufacture.

2/6 14 plus 8 ditto.

1/- 25 volt, 25 mfd. ELECTROLYTIC CONDENSERS, tubular type, by well-known manufacture.

10/6 P.M. MOVING COIL SPEAKER, 6in. cone, by well-known manufacture.

13/6 P.M. MOVING COIL SPEAKER, 7 1/2 in. cone, by well-known manufacture.

(Continued at top of column three)

SHORT WAVE KITS

Each of the following New Times Sales Co. offers, is entirely brand new or shop soiled only. Every component is guaranteed a genuine constructor's component. Orders over 5/- Carriage Paid. C.O.D. fee extra.

N.T.S. ALL WAVE 3 KIT

—WAVERANGE 12-2,000 metres.

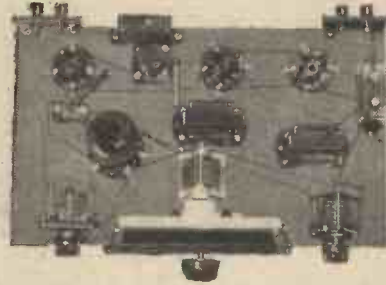

Build a set that will receive the whole world direct, for a very small outlay. Includes everything for immediate assembly: 1 Slow Motion Dial; 3 6-pin Coils, 12/26, 280/510, and 1,000/2,000 metres; 1 6-pin coil base, 3 4-pin baseboard mounting valveholders; 1 short-wave H/F Choke; 3 variable condensers, .0001, .0002, and .00016 MPD.; 2 Terminal mounts; 4 terminals; 2 L.F. Transformers; 2 fixed resistances; 2 L.F. condensers; 3 component brackets; 1 switch; 1 metal-sprayed baseboard; 1 coil connecting wire; 1 wiring diagram.

5/-
DOWN

Cash or C.O.D. Carriage Paid, £2:2:0 or 5/- down and 8 monthly payments of 5/-

N.T.S. SHORT WAVE ADAPTOR KIT



Hear America and all the World DIRECT on your present set, for only 17/6. Complete Kit of parts to build a reliable short-wave adaptor covering 12-94 metres. For use with any BATTERY receiver.

Kit comprises all parts for instant assembly, including metal-sprayed baseboard, 2 variable condensers, .00016, .0001 MPD., 2 baseboard mounting 4-pin holders, short-wave H.F. choke, grid leak, fixed condenser, adaptor plug terminal mount, two terminals, 3 4-pin plug-in coils, 12/26, 22/47, and 41/94 metres, 1 component bracket, slow-motion drive, Trimming condenser, connecting wire and wiring diagram. Built in one evening.

2/6
DOWN

Cash or C.O.D. Carriage Paid 17/6 or 2/6 down and 8 monthly payments of 2/6

N.T.S. MARVEL S.G.3 KIT

SIMPLICITY—EFFICIENCY

Newly-developed circuit, modern to the minute and using tested and matched components. The Kit includes 2-gang air-spaced condenser of advanced design; Slow Motion Dial; wave-wound coils on bakelised 1 1/2" x 2 1/2" base; super L.F. T in a transformer; solid dielectric reaction condenser; complete with ready-dressed chassis and all necessary valveholders, small condensers and resistances. (Blueprint showing How to Build the Marvel S.G.3 supplied FREE with each Kit.)



Cash or C.O.D. Carriage Paid £1:12:6 or 3/6 down and 8 monthly payments of 4/-

P.M. M.C. SPEAKER

BARGAIN AT 7/6

BRAND NEW Permanent Magnet Moving-Coil Speakers at less than cost. 6in. Cone. Large magnet and complete with input transformer suitable for Power, Super-Power or Pentode. State which type required when ordering. Cash or C.O.D., 7/6. (Carriage 6d. extra.)



56 (Pr.W.19), Ludgate Hill, London, E.C.4. EST. 1924

(Continued from foot of column one)
3/6 MULTI-PURPOSE VALVE, suitable for H.F. Pentode, list 21/-.
6d. TUBULAR CONDENSERS, wire end type, all sizes up to 0.1.
1/6 LISSEN CENTRE-TAPPED CHOKES, brand new, boxed.
1/- INTERVALLE CHOKES, brand new, boxed, Lissen manufacture.
5/11 MIDGET 2-GANG 0.0005 CONDENSER, fully screened, top trimmers, by well known manufacture.
Hours of Business: 9 a.m. to 7 p.m. Saturdays. 9 a.m. to 1 p.m.
All Orders value 5/- and Over, Post Free.
Orders under 5/- must be accompanied by a reasonable amount for postage.
Enquiries, 1 1/2d. stamp, if reply expected.

RADIO CLEARANCE

63, HIGH HOLBORN, W.C.1.
TEL.: HOLBORN 4631.

RECEIVERS, COMPONENTS AND ACCESSORIES

Surplus, Clearance, or Secondhand, etc.

VAUXHALL.—Magnavox mains energised, 2,500 or 6,500 field coil, 10in. cone, 17/6; 7in. cone, 12/6.
VAUXHALL.—Magnavox permanent magnets, universal, suitable for Class "B" power or pentode, 7in. cone, 16/6; 10in. cone, 22/-.
VAUXHALL.—American Rolax energised 2,500, 8in. cone, 15/-; 9 1/2in., 19/6. Permanent magnets. 19/6 and 24/6.
VAUXHALL.—Above, fully guaranteed, complete with humbucking coils; state power or pentode transformer; unused manufacturers' stock.
VAUXHALL.—Polar Midget 3-gang condensers, straight or superhet, 8/9; Polar full vision, horizontal or Arcuate dial and drives, 5/-.
VAUXHALL.—Flat, sheet aluminium, hard rolled, 18 gauge, 12in. x 12in., 3/-; 18 x 18, 5/6; other sizes proportionate.
VAUXHALL.—Polar station named scales, for horizontal dials, latest settings; 1/9 each.
VAUXHALL.—Colvern Ferrocar iron cored coils, 2-gang, 20/-; 3-gang, 30/-; straight or superhet. Colpaks, 44/-.
VAUXHALL.—Volume controls, Eric, Colvern, Centralabs, 2/-; with switch, 3/-; all values, from 3,000 to 2 meg.
VAUXHALL.—T.C.C. electrolytic condensers, 8 mfd. and 4 mfd., 550 volt, 3/-; 500 volt, 2/6; 450 volt, 2/5; 200 mfd., 10-volt, 2/6.
VAUXHALL.—T.C.C. condensers, tubular, non-inductive, 0.1, 6d.; 50 mfd., 50v. working, 1/6; 50 mfd., 12v., 1/3; 0.05, 6d.; 0.002, 0.0002, 0.001, 0.0001, 4d. each.
VAUXHALL.—T.C.C. mica 0.002, 2,000 volt test, 1/-; 0.0001, 4d.; 0.001, 0.01, 1/-; 1 mfd. Mansbridge, 1/3; 2 mfd., 1/8.
VAUXHALL.—Resistances by well-known manufacturers, 1-watt type, 6d. each; all values.
VAUXHALL.—Centre tapped iron cored I.F. transformers, buses, terminals, 110 k/c; 6/6 guaranteed.
VAUXHALL.—Set manufacturers' surplus, skeleton type Westinghouse rectifiers, H.T.8, 9/6; H.T.9, H.T.10, 10/-; complete with fixing brackets.
VAUXHALL.—Collaro 32 Model, A.C. 200-250v., first quality pick-ups and volume control, 45/-.
VAUXHALL.—Utility slow motion dials, graded 150 to 1, marked in metres, 10/6.
VAUXHALL.—Hivac or Tungaram, valves, all types, for immediate delivery, fully guaranteed.
VAUXHALL.—Clix valve holders, terminals, 6-pin, 7d.; 9-pin, 9d.; baseboard mounting, 5-pin, 4 1/2d.; 7-pin, 1/-.
VAUXHALL.—Pushback wire, four colours, 6yds., 6d. 6BA screws or nuts, 4d. doz.
VAUXHALL.—Immediate delivery, carriage paid, lists free; cash with order, or c.o.d.—Vauxhall Utilities, 103a, Strand, W.C.2 (Temple Bar 9338).

NEW RECEIVERS, COMPONENTS, AND ACCESSORIES

HULBERT for Quality Surplus Speakers. All Music Lovers should write for List of amazing bargains. Prices from 8/6 brand new. Made by best known British maker.—Hulbert, 6, Conduit Street, W.1.

CLARION VALVES.—All brand new, battery types, 2-volt, H.2, H.L.2, L.P.2, 1/9; super power P2, 2/6; screens and L.F. pentodes, 3/9; A.C. mains, 4-volt, 1-amp., general purpose, 3/3; power, 4/-; screens and L.F. pentodes, 4/6; full wave rectifiers, 3/6; postage paid, cash with order, or C.O.D. over 10/-.—Clarion Valves, Dept. 2, 885, Tyburn Road, Erdington, Birmingham.

RADIO BARGAINS

AMAZING Prices. New and Shop-soiled Mains and Battery Sets. Components, American, English Valve replacements. All-Wave Superhets. Listed at £11/11/- My Price £8/18/6. All-Wave Radio Gram. Chassis, Valves and Speaker listed at £8/10/- My Price £6/12/6. Lotus Midget AC/DC MC Speakers, 65/- stamp for list.—LITTLE, 2, Barras Lane, COVENTRY.

"In 'wireless' so called, it is strange
That good wiring effects such a change;
With FLUXITE," said Dad,
"I've made good what was bad,
And improved the reception
and range."



See that FLUXITE is always by you—in the house—garage—workshop—wherever speedy soldering is needed. Used for 30 years in government works and by leading engineers and manufacturers. Of Ironmongers—in tins, 4d., 8d., 1/4 and 2/8. Ask to see the FLUXITE SMALL-SPACE SOLDERING SET—compact but substantial—complete with full instructions, 7/6. Write for Free Book on the art of "soft" soldering and ask for Leaflet on CASE-HARDENING STEEL and TEMPERING TOOLS with FLUXITE.

TO CYCLISTS! Your wheels will NOT keep round and true, unless the spokes are tied with the fine wire at the crossings AND SOLDERED. This makes a much stronger wheel. It's simple—with FLUXITE—but IMPORTANT.

THE FLUXITE GUN

is always ready to put Fluxite on the soldering job instantly. A little pressure places the right quantity on the right spot and one charging lasts for ages. Price 1/6.



ALL MECHANICS WILL HAVE

FLUXITE

IT SIMPLIFIES ALL SOLDERING

FLUXITE LTD. (Dept. W.P.) DRAGON WORKS, BERMONDSEY STREET, S.E.1.

For SHORT WAVE Enthusiasts

Get your copy early!

Illustrated constructional articles for building simple S.W. battery sets; battery and A.C. mains superhet S.W. receivers with A.V.C.; Ultra S.W. Radio Telephone; Transceiver; S.W. Converters; Crystal-controlled Amateur Bands Transmitter, etc. From your Radio Dealer, W. H. Smith & Sons, or from Stratton & Co., Eddystone Works, Birmingham, 5. London service: Webb's, 14, Soho St., W.1.

EDDYSTONE 1937 SHORT WAVE MANUAL

"ENGINEERING OPPORTUNITIES" FREE!



This unique Hand-book shows the easy way to secure A.M.I.C.E., A.M.I.Mech.E., A.M.I.E.E., A.M.I.A.E., A.M.I.W.T., A.M.I.R.E., and similar qualifications. WE GUARANTEE—"NO PASS NO FEE." Details are given of over 150 Diploma Courses in all branches of Civil, Mech., Elec., Motor, Aero, Radio and Television Engineering, Building, Government Employment, etc.

Write for this enlightening Hand-book to-day FREE and post free. British Institute of Engineering Technology, 409, Shakespeare House, 17, 18, 19, Stratford Place, W.1.

RECEIVERS, COMPONENTS AND ACCESSORIES

Surplus, Clearance or Secondhand, etc.

SOUTHERN RADIO'S WIRELESS BARGAINS. ALL GOODS GUARANTEED AND SENT POST PAID.

SPEAKERS.—Celestion Soundex Permanent Magnet, 10/-; Telsen Permanent Magnet with ten-ratio transformer, 12/6; Telsen Loud Speaker Unit, 2/6; all new and boxed.

RECEIVERS.—G.E.C. A.C. D.C. Mains Three-valve sets. Complete with 3 Osram Valves, in exclusive Bakelite cabinet with Osram M.C. Speaker. Ready to plug in to any mains. Fully guaranteed. New, in sealed cartons, £3/5 (list £7/15).

G.E.C. Compact 3-valve Battery Sets complete with 3 Osram valves, moving coil P.M. Speaker in attractive Bakelite cabinet, makers' 1936 series in original sealed carton, 50/- (list £5/10/0).

MULLARD M.B.3 3-valve Battery Sets. Complete in handsome Walnut Cabinet, P.M. Speaker, 3 Mullard Valves (pentodes), Exide Batteries and Accumulator, £4/10/0 (list £8/8/0). Brand new. Sealed.

TELSEN A.C. D.C. MULTIMETERS (latest 1936 type).—5-range for every conceivable test for radio and domestic electrical appliances, 8/6 each.

COILS.—TELSEN (1936). Iron-cored Coils, Type W349, midjet size, 4/-; Type W478 (twin), 9/-; type W477 (triple), 16/-; type W476 (triple superhet selector and oscillator), 10/- set. All Ganged Coils are Mounted on Base with switch. I.F. Transformer Coils W482, 5/-; Telsen Dual Range Coil with variable series condenser W76, 4/-.

MICROPHONES.—Acc (P.O.) Microphones, complete with transformer, perfect with any type of receiver, 4/6.

TRU-OHM RESISTANCES.—1 Watt. Wire ends colour coded and marked; 36 assorted capacities on card, 6/-.

AMERICAN VALVES.—A full range of valves for all American sets at 7/- each. Brand new, guaranteed.

REPAIRS.—Any type of Receiver, American, British, etc. Repaired by Expert Staff.

SOUTHERN RADIO BRANCHES.—271/275, High Road, Willesden Green, N.W.10; 46, Lisle Street, W.C.2. All mail orders to 323, Euston Road, N.W.1.

SOUTHERN RADIO, 323, Euston Road, London, N.W.1 (near Warren Street Tube). 'Phone: Euston 3775.

MISCELLANEOUS

YOU CAN QUICKLY MAKE YOUR SPARE TIME BRING YOU A FULL-TIME INCOME by starting a Mail Order Business of your own at home. Simple new Plan is now ready for you to use. Follow the lead of others who are averaging £12 per week net profit. Get away from the dull drudgery of a poorly-paid routine job. Join the big-money class and work for your own profit. No previous experience, special training or talent required. Suitable for any age or either sex. Few pounds' capital only needed. No samples or "outfits" to buy. No rent, rates or other "overhead" expenses; no canvassing to do; no expensive stocks to carry. In your own home, however small, or wherever situated, you can run one of the most interesting businesses ever devised. From the very beginning you secure results. Gradually you extend your operations and make your earnings grow. For Mail Order and Postal Trading offers immense scope—more and more business is being done by post. And our remarkable new Plan makes success certain. Best of all, you can use it for your own profit without interfering with your present occupation or without anyone being the wiser. You are shown exactly how to operate this Plan in your spare time in order to increase your earnings and build up your own money-making business giving, when you wish, your whole time and energy to it. Seize this wonderful opportunity now; say "good-bye" for ever to poor pay, monotony and "making ends meet." Be independent and make your future secure. Investigate this novel money-making Plan and see how easily you can use it—it costs nothing and commits you to nothing. Send P.C. to-day for fascinating FREE Booklet to: Business Service Institute (Dept. 891c), 6, Carmelite Street, London, E.C.4.

VALVES

VALVES. By well-known manufacturer. Complete range of Battery, A.C. Mains, Rectifiers. Brand new stock with six months' guarantee. 2 volt Detector, 2/3, Power, 2/6, Screen Grid, Pentode, H.F. Pentode, 5/-. The following American type valves, fully guaranteed, at 5/6 each: No. 80, 42, 43, 57, 58, 77, 78, 6C8, 6D8, 25Y5, 25Z5. Write for other prices to: Dulci Electrical Co., Ltd., 7, Lizard Street, London, E.C.1.

SHORT WAVES

SHORT WAVE on a crystal set. Full building instruction and crystal, 1/2 post paid.—Radiomall Tanworth-in-Arden, Warwickshire.

21/- B.T.C. SHORT-WAVE GUINEA KIT. Latest design for CONVERTER-ADAPTOR-ONE VALVER, 13/5 m. Excellent reception reports. Descriptive Leaflets P.G.K., 11d. stamp, including U.S.W. TELEVISION CONVERTER Guinea Kit. BENNETT TELEVISION CO., REDHILL.

"QUALITY"



Special 6-VALVE BAND-PASS SUPERHETERODYNE

Price complete with B.V.A. valves £6 : 10.

Specially designed and built for high quality radio/gram work.

SPECIAL FEATURES: Reinforced stout steel chassis. High class components by well-known makers of acknowledged reputation used throughout. Fitted with attractive and specially large full-vision dial, glass-fronted, and supplied complete with centobron and fittings. Separate illumination automatically switched in for radio/gramophone.

CIRCUIT DETAILS: Inductively coupled band-pass filter, triode-hexode frequency changer, band-pass I.P.T. coupled I.F. amplifier, I.P.T. coupled to diode detector. D.A.V.C. applied to preceding valves. I.F. amplifier capacity coupled to output pentode 3-11 watts undistorted. Variable tone control and volume control operate on both radio and gramophone. Alternative triode output FK4 or AC04 10s. extra.

All receivers supplied complete with valves, knobs, pilot lamps, leads, mains cable and plug. 12 months' guarantee. Deferred terms on application to London Radio Supply Co., 11, Oat Lane, E.C.2.

MCCARTHY RADIO LTD.
44a, Westbourne Grove, Bayswater, W.2

Telephone: Bayswater 3201/2

FREE! RADIOGRAPHIC WONDER CATALOGUE.

EVERYTHING IN RADIO AT WORLD'S LOWEST PRICES. RADIOGRAPHIC LTD., 66, OSBORNE STREET, GLASGOW, C.1.

NEW RECEIVERS, COMPONENTS AND ACCESSORIES

RADIO AND ENGINEERING SUPPLIES. ALL SHORT-WAVE BARGAINS offered last week still available.

Send stamp for Short-wave bargain lists. R.E.S. guaranteed Eliminators. It will pay you to write for particulars.

TRADE. Send stamp for lists. **RADIO AND ENGINEERING SUPPLIES, 88, Edgware Rd., London, W.2.** 'Phone: Paddington 6652.

BANKRUPT BARGAINS. List free. Few only Mullard 6v. A.C./D.C. superhets. MU35 and battery MB3A receivers. Right prices. Trade supplied with the new Ferguson all-wave superhets. Telsen 6v. A.C. superhet complete, £5/10/0. Ultra model 25 13gn. superhet D.C., £2. Pilot and Truphonic new 1937 receivers. Any make supplied; get my prices and part exchange offers first. Large stock replacement valves, speakers, and most components at very low prices. Established 1920.—Butlin, 6, Stanford Avenue, Brighton.

MISCELLANEOUS

WESTERN ELECTRIC Microphones, 1/6 each, post free; Transformers to match, 1/3; 500 clearance lines, catalogues 3d. each.—J. Bearfield, 105, Upper Street, London, N.1.

HEADPHONES. Brown, G.E.C. B.T.H., Nesper, Sterling, Ericsson, Marconi, Telefunken, etc., from 2/6 pair. Postage 6d. Listfree. **CRYSTAL SETS.** Complete. Guaranteed. Burne-Jones, 5/6. Ditto, double circuit, 8/-. Large P.O. type, 10/- Crystal detector. Complete parts, 1/-. Sensitive permanent detector, 1/6.—Post Radio, 183, Caledonian Road, London, N.1.

WE WILL MAKE A GENEROUS ALLOWANCE on your old set or components in part exchange for any new receiver or Peto-Scott kit. Write for FREE EXPERT ADVICE before making your final choice. You are then assured of COMPLETE SATISFACTION. Prompt delivery of all the latest models.—R. Wigfield, Furlong Road, Goldthorpe, Yorks.

Osram Valves
REGD TRADE MARK
Made in England

TYPE N43
POWER AMPLIFYING PENTODE
With Indirectly Heated Cathode
(For operation from A.C. Mains).

The OSRAM N43 is an Indirectly Heated Pentode designed to combine high sensitivity, large undistorted power output and a low value of interelectrode capacitance. To achieve these results the type has a high value of mutual conductance and employs an electrode design with a grid taken in a top cap connection which results in a normal power amplifying pentode.

Type N43 is thus particularly applicable to high frequency or amplifiers, or to the output stage of channels in Television Receivers which are required with a very wide band of audio frequencies and attenuation.

CHARACTERISTICS.

Heater Voltage
Heater Current
Anode Voltage
Grid Voltage
Anode Current average
Screen Current average
Anode Modulation
Mutual Conductance
Optimum Load Resistance
Automatic Bias Resistance
Interelectrode Capacities:
Grid to Anode
Anode to other Electrodes (Output)
Grid to other Electrodes

Osram Valves
REGD TRADE MARK
Made in England

TYPE W42
VARIABLE MU SCREEN PENTODE
Indirectly Heated Cathode
(For operation from A.C. Mains).

W42 is a Variable Mu Screen Pentode in a high frequency or intermediate frequency tuning. The variable Mu characteristic of anode to be effected by variation of A.C. to the operating grid base is adequate for the control of the input capacity and is of the layout of certain receiver designs.

CHARACTERISTICS.

Max. 4.0
Recommended Operating Conditions
25 0.5 amp approx
100 0.5 amp approx
100 0.5 amp approx
100 0.5 amp approx
100 0.5 amp approx
1.75 mA/V (at E_b = 0)
0.005 mA/V
0.005 mA/V mid approx.
10.4
5.1

Osram Valves
REGD TRADE MARK
Made in England

TYPE U16
RECTIFYING VALVE
With Directly Heated Filament
(Half Wave).

The OSRAM U16 is a Rectifying Valve incorporating a dual electrode system in one bulb. Rectification of both half cycles of the A.C. wave is obtained when the valve is fed from an A.C. supply through a suitable transformer.

The valve is of long life and consistent voltage and output.

4.0
3.75 amp approx.
0 mA

Osram Valves
REGD TRADE MARK
Made in England

TYPE D42
SINGLE DIODE
With Indirectly Heated Cathode.

The OSRAM D42 is a Single Diode Valve with more generous emission than type D41.

It is suitable for use as a second Detector in super-heterodyne receivers, and also as a rectifier to provide A.C. voltage.

Type D42 is not suitable for use as a power rectifier.

CHARACTERISTICS.

6.0
0.6 amp
75 volts K
12 mA/V
4.0 mA

Osram Valves
REGD TRADE MARK
Made in England

TYPE H41
MINIATURE LOW CAPACITY TRIODE
With Indirectly Heated Cathode.

The OSRAM H41 is an Indirectly Heated Triode of special design intended to reduce the capacitance between the electrodes of their respective support and to obtain a minimum in order to achieve the most efficient and of the normal low capacity triode.

Its operation is ultra-silent and applied to the ultra-silent type.

Osram Valves
REGD TRADE MARK
Made in England

TYPE H42
DETECTOR AND AMPLIFYING TRIODE
With Indirectly Heated Cathode
(For operation from A.C. Mains).

The OSRAM H42 is a Triode for use as a detector and amplifier, and also as a power amplifier.

CHARACTERISTICS.

Heater Voltage
Heater Current
Anode Voltage
Grid Voltage
Anode Current
Amplification
Impedance
Mutual Conductance
Optimum Load Resistance
Automatic Bias Resistance
Interelectrode Capacities:
Grid to Anode
Anode to other Electrodes
Grid to other Electrodes

Osram Valves
REGD TRADE MARK
Made in England

TYPE U16
RECTIFYING VALVE
With Directly Heated Filament
(Half Wave).

The OSRAM U16 is a Half Wave Rectifier Valve designed primarily to supply the accelerator, or anode of withstanding Cathode Ray Tubes. For this purpose it is capable of withstanding an anode voltage up to 5,000 volts R.M.S. and the rectified current output is adequate.

The type is not intended for power rectification purposes where rectified currents greater than 2 milliamperes are required.

CHARACTERISTICS.

Max. 4.0
Recommended Operating Conditions
25 0.5 amp approx
100 0.5 amp approx
100 0.5 amp approx
100 0.5 amp approx
100 0.5 amp approx
1.75 mA/V (at E_b = 0)
0.005 mA/V
0.005 mA/V mid approx.
10.4
5.1

Osram Valves
REGD TRADE MARK
Made in England

TYPE U17
RECTIFYING VALVE
With Directly Heated Filament
(Half Wave).

The OSRAM U17 is a high voltage Half Wave Rectifier Valve designed to supply the anode voltage up to 2,500 volts R.M.S. with an output of 30 mA. The type is suitable for use where anode voltages necessary for Cathode Ray Tubes are required.

CHARACTERISTICS.

Max. 4.0
Recommended Operating Conditions
25 0.5 amp approx
100 0.5 amp approx
100 0.5 amp approx
100 0.5 amp approx
100 0.5 amp approx
1.75 mA/V (at E_b = 0)
0.005 mA/V
0.005 mA/V mid approx.
10.4
5.1

To all those who require full and comprehensive technical data and characteristic curves of any particular valve, these leaflets will give you all the information you require.

Osram Valves
MADE IN ENGLAND

Any leaflet available post free on request

There is also a copy of the Osram Valve Guide at your disposal giving full particulars (including circuits) of the whole valve range, in handy pocket size.

Adv. of The General Electric Co., Ltd., Magnet House, Kingsway, London, W.C.2.

FREE BLUEPRINT OF F. J. CAMM'S "RECORD" ALL-WAVE THREE!

Practical and Amateur Wireless

3^d
EVERY
WEDNESDAY

Edited by F. J. CAMM

a GEORGE
NEWNES
Publication

Vol. 9. No. 215.
October 31st, 1936.

AND PRACTICAL TELEVISION

F. J. CAMM'S
"Record"

The Ideal
ALL-WAVE SET
for Everyman

"ACCUMULATORS"

A Newnes Home Mechanic Book that will cost you only 1/- net and save you pounds. How to get the best out of your Car or Wireless batteries. Obtainable from all newsagents and booksellers or 1/2 post free from . . .

GEORGE NEWNES LIMITED, 8-11 Southampton Street, Strand, W.C.2.

FOR THE TECHNICAL EXPERT

Details of the new "HIS MASTER'S VOICE" ALL WAVE FLUID LIGHT SUPERHET RECEIVER

MODEL 482 A.C. PRICE 16 GUINEAS



The new "His Master's Voice" all wave superhet receiver, Model 482, is one of five all wave receivers being marketed by "His Master's Voice" this season. We hope the following details will be of interest to the technical expert who is considering the purchase of a commercial receiver, or the expert who is often consulted by listeners not possessing a highly technical knowledge.

MODEL 482 is a six valve (plus detector), all wave superhet receiver for A.C. mains, in a figured walnut table cabinet.

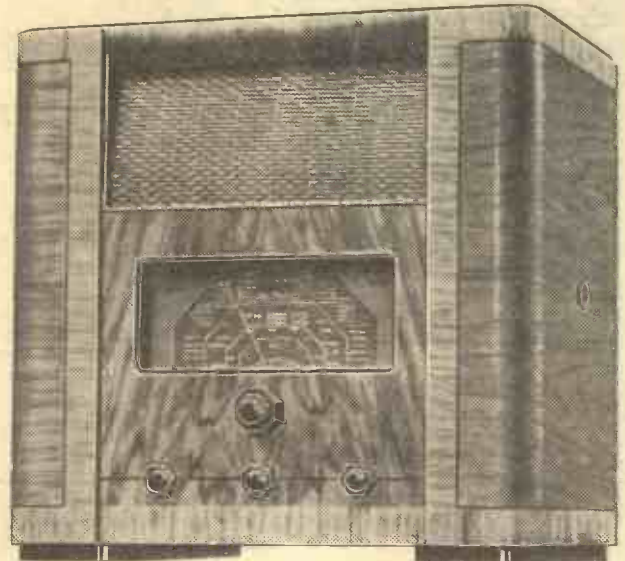

WAVE RANGE 16.5 to 51.5 metres. 200-580 metres. 725-2,000 metres.

CONTROLS Apart from the Mains Switch, which is mounted at the side of the cabinet, there are four operating controls—Volume, Waveband, Tone and Tuning. The controls are situated on the front of the cabinet below the Tuning scale.

TWO-SPEED TUNING

The Tuning control is of the two-speed type with fast and slow knobs arranged concentrically. These knobs drive simultaneously the main wavelength indicator and a vernier scale. The main indicator travels across the illuminated wavelength scale, which bears the names of over eighty medium and long wave stations, besides the wavelength calibrations of the three bands. The wave bands of the principal short wave stations are indicated by special markings.

VERNIER SCALE

The vernier scale is calibrated in degrees of 0 to 100, and rotates five times to one complete movement of the pointer across the wavelength scale. It will be realised that with this arrangement the exact point of the reception of each short wave station can be noted for future reference.

WAVE BAND INDICATOR

An ingenious lighting scheme illuminates the station names and wavelength calibrations, leaving the rest of the scale dim. A wave band indicator is situated at the top corner of the scale, and shows which wave band is in use. It is actuated by a control knob on the front of the receiver.

CATHODE RAY FLUID-LIGHT

The fluid-light tuning device is of the electronic cathode ray type and is extremely sensitive. The device is semi-circular in shape, and when the receiver is not tuned to a station two arcs of light are apart. As the receiver is correctly tuned the arcs converge.

VOLUME CONTROL

The volume control is wired in the grid circuit of the LF amplifier, and is operative on both radio and gramophone pick-up.

5 POINT TONE CONTROL

The five-point tone control which operates both on bass and treble, will be found extremely useful as the best setting can be obtained for each station. It operates on radio and gramophone pick-up, which may be connected to two sockets.

AERIAL Sockets are provided for either "His Master's Voice" all-wave anti-static aerial, or a doublet aerial.

SPEAKER Energised field moving coil speaker incorporating a special cone to give a good response on both high and low notes. The flux density is 7,500 lines. A "Sound transparent" metal grille is mounted on the cabinet in front of the speaker. Sockets are provided for the connection of additional external speakers.

CONSUMPTION & VOLTAGES

85 watts on A.C. voltages from 95-260 50-100 cycles.

CIRCUIT

The circuit and chassis have been designed to keep stray capacities to an absolute minimum, and the valves employed have low inter-electrode capacities. In this way the absolute maximum degree of sensitivity and selectivity has been obtained on all wave ranges, particularly on the short wave range. The valve complement is as follows:

- W42 H.F. amplifier.
- X42 Mixer.
- W42 I.F. amplifier.
- D41 Speech and AVC double diode.
- H42 L.F. amplifier.
- N42 Pentode output.
- U14 H.T. Rectifier.

It will be noticed that the employment of valve D41 looks after speech rectification and the production of AVC voltages, and as the latter are applied to the three previous valves, the AVC control is very efficient. The speech output from valve D41 is via resistance capacity coupling through the H.42 valve to the high efficiency pentode N42 which has an output of three watts undistorted.

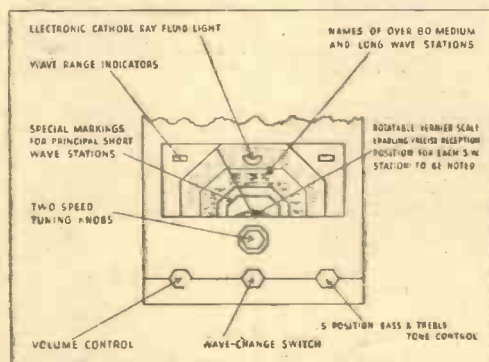

If you would like to receive a copy of the "H.M.V." illustrated catalogue of RADIO receivers and Radiogramophones write to :—
"HIS MASTER'S VOICE" 98-108 Clerkenwell Road, E.C.1.

THE BEST ALL-WAVE SET

See Page 191



Practical

and Amateur

Wireless

Edited by F. J. CAMM

Technical Staff:
W. J. Delaney, H. J. Barton Chapple, Wh.Sch.,
B.Sc., A.M.I.E.E., Frank Preston.



VOL. IX. No. 215. October 31st, 1936.

ROUND *the* WORLD of WIRELESS

Billy Merrin and His Commanders
THIS popular band will be the variety feature to be broadcast from the stage of The Palace Theatre, Plymouth, on November 4.

After Twenty-two Years

THE Band of the First Battalion the Queen's Own Cameron Highlanders will be heard in the Scottish programme on November 6th, twenty-two years after it last played in Edinburgh. That was on August 12th, 1914, when the Battalion marched from Edinburgh Castle to Waverley Station on the way to France. The regiment has been on foreign service since 1919.

French Interval Signals

THE Paris Studio, P.T.T., has adopted some novel signals to render identification easier to both home and foreign listeners. The broadcasts now usually open with a fanfare of trumpets which is actually a recording of the instrumentalists of the famous Garde Républicaine. In the intervals the first bars of an old folk-song "Si le Roi m'avait donné Paris" may often be heard, and sometimes a metronome beat is radiated.

Volga Boatmen—Up to date

ON the canals between Volga and Moscow the locks are now being controlled from a central point, owing to reconstruction arrangements. The official on duty is provided with a television receiver, and a transmitter is installed at the entrance to the canal. The controlling official is thus able to see the position and make the necessary arrangements for controlling barges on the canal.

New Zealand N.B.S.

THE National Broadcasting Service in New Zealand has been reorganised, and Professor James Shelley has been appointed Director. The Prime Minister, the Rt. Hon. M. J. Savage, is Minister of Broadcasting. Professor Shelley was for a time Chief Instructor of the War Office School of Education.

Lighthouse Communication

A FEW months ago wireless transmitting apparatus displaced carrier pigeons for communication between the lighthouse on Ailsa Craig and the mainland. The first SOS message since its installation has just been sent across the Firth of Clyde. A call

was made for medical aid for one of the keepers of the lighthouse and the doctor on the Island. The message was picked up by Turnberry lighthouse and shortly after a boat with assistance was sent out.

Police Radio for Scotland

THE little town of Airdrie is to have one police radio equipped patrol car, thus coming into line with the other towns in Scotland. The Secretary of State for Scotland approved their estimate for the provision of a radio car, but suggested that cheaper radio apparatus be installed. The local town council have agreed to take this course.

Newcomer's Hour at Dublin

THIS popular feature is to be resumed from Dublin on November 21st. The successful competitor in each Newcomer's Hour will be given a prize of three guineas, and the broadcast is divided into four sections—singers in Irish, singers in English and other languages, solo instrumentalists, and variety items. The latter is to include humorous songs, whistlers, comedy duets, etc. Application forms are available for those over eighteen years of age who have not broadcast during the past two years as soloists.

And Now Cuba

FROM G.M.T. 22.00, every night you may now hear a good signal from COCX, Havana (Cuba), on 25.7 m. (11,675 kc/s). The studio resorts to sponsored programmes

in the Spanish language, with occasional English translations and frequently refers to Philco and R.C.A. Victor. Three chimes are used as an interval signal. The address given is P.O. Box 32, Havana, Cuba.

Solving a Puzzle

THE station which has been reported on 48.78 m. (6,150 kc/s) as HIN is, in fact, HI5N, *La Voz del Almacén*, in Santiago (Dominican Republic). HIN, previously on 47.89 m. (6,265 kc/s) has been identified on 26.60 m. (11,280 kc/s). It is an easy matter to mistake the call, but on a recent occasion the frequency was announced.

A Peculiar Connection

A RECENT issue of the "Cossor Courier" points out that there is a connection between green bananas, dandelions, and radio sets, inasmuch as all three contain rubber. In radio sets, of course, it takes the form of insulated material, whereas in bananas and dandelions it takes the form of tiny globules in the milky fluid that you can see if you crush them.

Various Uses of the Cathode-ray Tube

ALTHOUGH the cathode-ray tube is almost invariably associated with television, it has a hundred and one other uses, and is in everyday employment for photographing heart-beats, designing motor-car engines, measuring the impact of waves on breakwaters, direction finding, investigating the phenomena of the Northern Lights, and has, in fact, a use in almost every industry and science. It has been suggested that the cathode-ray tube and suitable equipment might even be used for detecting the position and depth of shoals of fish to facilitate trawling.

Sun and a Fade-out

AT the Mount Wilson Observatory recently a sudden gas eruption on the sun was reported. It was then ascertained that at the same time short-wave signals completely disappeared for about fifteen minutes. Subsequent investigation showed that the signal disappearance took place over that part of the earth which was lighted by the sun at the time. This is claimed to be the first definite evidence linking signal variations with gas eruptions on the sun.

ON OTHER PAGES

	Page
The Record Three ...	191
On Your Wavelength ...	199
Breakthrough ...	203
Practical Television ...	207
Data Sheet ...	220
Short-wave Section ...	213
B.L.D.L.C. News ...	215
ABC of the Modern Receiver ...	217
Facts and Figures ...	222
Letters from Readers ...	224
Queries and Enquiries ...	225
Blueprint Service ...	226

THE PICK of the PROGRAMMES

City of Birmingham Orchestra

LESLIE HEWARD conducts the City of Birmingham Orchestra in the first symphony concert of the season which will be broadcast from the Town Hall, Birmingham, on October 29th. The programme includes the Brahms No. 3 Symphony and Mozart's Sinfonia Concertante in E Flat, with Jean Pougnet as solo violinist and William Primrose as solo viola player. During the interval there will be a talk by Wilfrid Rooke-Ley.

**MAKE THESE DATES
WITH YOUR RADIO**

Symphony Concert from Leeds

SIR HAMILTON HARTY is to conduct the Northern Philharmonic Orchestra in a concert which will be broadcast from

HERE COMES THE BRIDE!



For the first time in this country a television broadcast of an exhibition took place at the beginning of this month at the North London Exhibition at Alexandra Palace. Our illustration shows the E.M.I. "Emitron" camera televising a bridal party during a parade of mannequins.

Follies on Tour

THE popular Arcadian Follies concert party go on tour during the autumn and winter, and on October 30th listeners to the Northern programme will hear them broadcasting from the Grand Theatre, Doncaster.

Concert from Torquay

THE Torquay Municipal Orchestra, conducted by Ernest W. Goss, will broadcast a concert from the Pavilion, Torquay, on November 3. Henry Gill (baritone) and Irene Kohla (pianoforte) will be the solo artists.

Outposts of Empah

PUKKA sahibs and other adventurers may shuffle uneasily in their chairs on October 31st, when Jack House and Allan Mackinnon propose to deal with them humorously, but faithfully, in an amusing revue entitled "Outposts of Empah." The cast will include mem-sahibs, pukka planters, sturdy settlers, bearded beach-combers, and those exiled aristocrats, Hons. across the sea. The programme is being produced by Robin Russell.

The Clifton Light Orchestra

THIS well-known orchestra, conducted by J. Leslie Bridgmont, will broadcast from the Orchestral Studio on November 3. A feature of the programme will be Winifred Davey (pianoforte) playing Gershwin's "Rhapsody in Blue," accompanied by the orchestra.

Leicester Accordion Band

THIS band, which consists of eleven skilled performers, got into the prize list at the Accordion contest in London last year, and has entered for the open championship in November. The band will be heard "on the air" for the first time on October 31st in the Midland programme. T. J. Buffey is the musical director.

Coventry Silver Band

THIS old-established band, conducted by W. Ellison, will render a popular programme of light music from the Midland Regional on November 3rd. In the interludes there will be songs by the Cleff Trio, which consists of Isabel Tebbs, Edith Paddock, and Dorothy Birt.

Organ Recital from Truro Cathedral

IN the series of broadcasts entitled, "Some Organs of the West Country," F. G. Ormond will broadcast an organ recital from Truro Cathedral on October 29th in the Western Regional programme. Some well-known church musicians have begun their career in Truro Cathedral, including the late Dr. G. R. Sinclair, organist of Hereford Cathedral; Hubert Middleton, of Trinity College, Cambridge; and J. Dykes Bower, recently appointed to St. Paul's Cathedral.

B.B.C. Midland Orchestra

ON November 2nd Reginald Burs-ton will conduct the B.B.C. Midland Orchestra in a programme of light music including a Lehar pot-pourri arranged by Geiger, the suite "Three Country Pictures" by Montague Phillips, and a selection from "La Traviata."

"1066 and All That"

THE microphone visits the New Theatre, Oxford, for a pot-pourri of songs and tunes from the popular show, "1066 and All That," with Reginald Arkell's music. It is being presented by Emile Littler in asso-

ciation with Sir Barry Jackson. The compère is Cyril James; among the singers are Robert McLachlan as Henry VIII; Mabelle George as Catherine Parr; and Kevan Bernard as the Common Man.

North Regional Follies

THIS concert party, produced and presented by Fred E. Rayne, will be heard in a broadcast from the Theatre Royal, Bristol, on November 6th.

Reid Symphony Orchestra

AN orchestral concert by the Reid Symphony Orchestra, led by Kenneth Anderson and conducted by Sir Donald F. Tovey, will be broadcast in the Scottish programme on November 5th. The broadcast portion includes the Overture to the "Flying Dutchman," the Introduction to the Third Act of "Tannhäuser" (original version), the "Venusberg Ballet" and Prelude to "Lohengrin," all by Wagner. The broadcast comes from the Usher Hall, Edinburgh.

Variety from Sheffield

A VARIETY programme from the Lyceum Theatre, Sheffield, will be included in the evening broadcast from the Northern Regional on November 4th. The bill from which an excerpt will be taken includes Leon Fisher and Ritta Ariani (vocal and musical act); The Three Virginians (vocal and piano); Alec Finlay ("Scotland's Gentleman"); Betty Fields (comédienne)—Gracie Fields' sister; Plant and Roslyn (comedy duo); and David Stone and Timothy (ventriloquial act).

SOLVE THIS!

PROBLEM No. 215.

Webster constructed a three-valve battery receiver of the S.G., det., pentode type. When the set was switched on no signals could be heard, but it was found that satisfactory reception could be obtained by using a triode power valve in the pentode socket. The pentode valve was in order and the correct bias voltage was being applied to it. What was the trouble? Three books will be awarded for the first three correct solutions opened. Address your solutions to the Editor, PRACTICAL AND AMATEUR WIRELESS, Geo. Newnes, Ltd., 8-11, Southampton Street, Strand, London, W.C.2. Envelopes must be marked Problem No. 215 in the bottom left-hand corner, and must be posted to reach this office not later than the first post on Monday, November 2nd, 1936.

Solution to Problem No. 214.

The field winding of the speaker was broken. This winding was connected across the rectifier-output circuit, as is usual in A.C./D.C. receivers, and therefore the fault did not materially affect the anode voltages and currents.

The following three readers successfully solved Problem No. 213, and books are accordingly being forwarded to them: A. H. Spooner, 38, Church Street, Accrington, Lancs; E. A. Griffiths, 29, Watery Lane, Wrexham; E. Richards, 104, Osbaston Park Road, Derby.

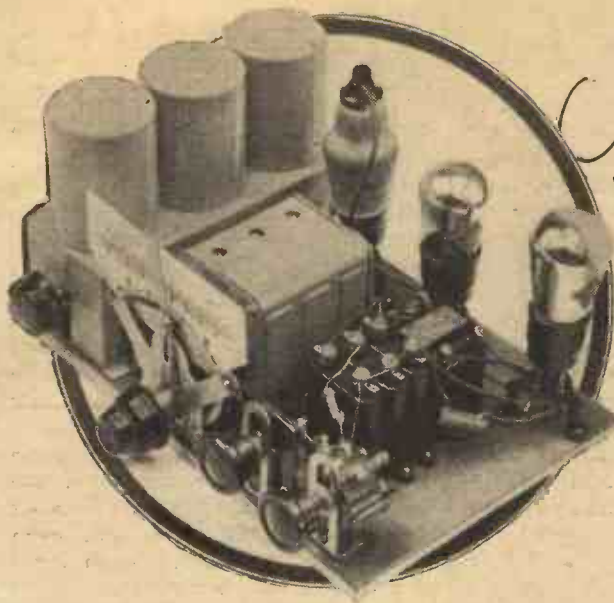

Building **F.J. CAMM'S**
 "Record"

All-wave Three

Full Constructional Details of My Latest All-wave Receiver Which is Backed by My Usual Guarantee, and for Which a Full-size Blueprint is Given in This Issue. You will be Proud of This New Receiver, Which is One of the Simplest to Operate and Brings in Programmes from Remote Quarters of the Globe at Excellent Loudspeaker Volume
 By F. J. CAMM

THE design of wireless sets has pursued a tortuous path since 1921. It has peregrinated through the crystal set stage to mediocre valve sets; neutrodyne circuits, screened-grid circuits, 'dynes, and 'odes, superhets, reflex circuits, and the whole gamut of stunt circuits from which much was expected but little achieved. Such a course is one of the inevitable corollaries of a new science, for designers must explore that political miasma known as "every avenue" before they can approach the ideal receiver.

But design is never static, nor can it ever be, for, as soon as the designer has perfected a receiver for a given set of transmitting conditions, those conditions change. We find the power of transmitting stations increased, more stations being crowded into comparatively narrow wavebands, the location of the station may be changed, and radio spreads to those countries which formerly knew it not.

It will never be possible to suppress nor kill the nomadic instincts of the listener. It was tried in Germany with the People's Set, on which a limited number of stations only could be received, but that effort failed. You cannot confine the interests of the public to the environs of their particular demesne. If they buy a motor-car they like to roam far from the madding crowd, even though under the present traffic conditions they meet ignoble strife. The greatest advantage of radio is

that it keeps you in touch with other nations, and if nation does not as yet speak peace unto nation, listeners at least find a common interest in the social activities and outlook of other races.

Any attempt to restrict the appeal of broadcasting by producing receivers which act like an automatic telephone—in which you dial the particular station you want to receive from a limited number of possible

programmes—would not only fail but would defeat the very object of radio entertainment. The diversified taste of the public causes them to seek their radio entertainment from all quarters of the globe, in just the same way as some members of the public enjoy the theatre whilst others

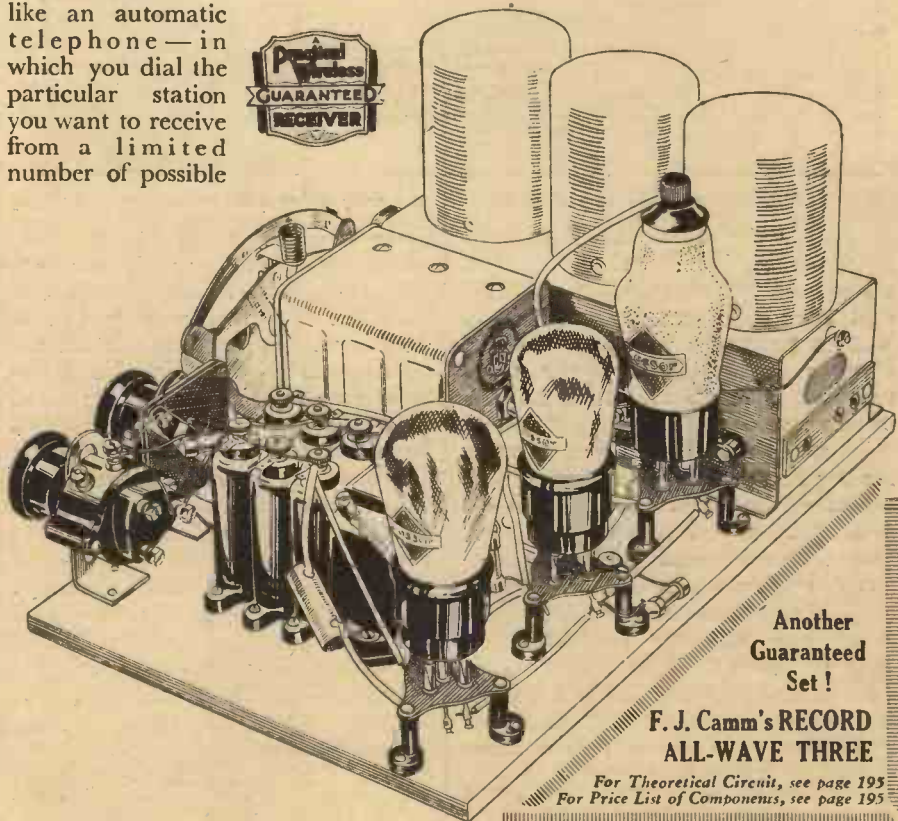

Another
 Guaranteed
 Set!

**F. J. Camm's RECORD
 ALL-WAVE THREE**

*For Theoretical Circuit, see page 195
 For Price List of Components, see page 195*

Easily Built in an Evening!

prefer a *thé-dansant* or a bridge party.

Medium-wave Congestion

Pleasure tends to destroy itself by its own popularity. You find an excellent parallel in motoring, where the roads have now become so congested that a journey becomes more of an aggravating experience than a pleasurable pastime. So with radio. You find within a compass of 350 metres hundreds of medium-wave stations all clammering for your attention and causing chronic con-

are still there and they are still entertaining to the serious experimenter. The listener to-day, however, does not wish to operate two receivers. He requires one which is capable of tapping all of the wavelengths. He requires the short-wave stations to be tuned in with the same ease as that to which he has become accustomed on the medium and long-wave bands. I base my judgment on the colossal demand at this year's Radio Show for all-wave receivers, and the tremendous interest displayed by visitors.

growing in volume during the past eighteen months, a demand which has been met by the publication in this journal of several excellent all-wave receivers of the mains and battery type. They have all been built on chassis, but I am assured by a large number of correspondents that a set built on a baseboard would be even more popular because it would encourage the beginner without offending the expert.

At the last Radio Show some dozens of readers called upon me to impress upon me the need for a set of the baseboard type, and even while the Show was still open I got to work, interviewed manufacturers of components, drafted a provisional circuit, and commenced experiments. These have led up to the production of the Record All-wave Three, and you will agree upon inspection of the blueprint and photographs that it is as simple an all-wave receiver as it is well possible to make. Its performance, however, is equal to anything I have obtained from more elaborate circuits, and I have no doubt as to the successful welcome which readers will accord it. Unfortunately it is not possible in cold print (at least, not yet) to let you hear it before you decide to build, but fortunately you know from past experience that I stand behind my designs, and you may rely upon my assistance and service if you fail to obtain excellent results.

The "Record" in my opinion is the easiest all-wave receiver to tune. The reaction is particularly smooth on all bands and thus banishes one of the greatest drawbacks to short-wave radio—reaction plop. Reception is equally good in day as nighttime.

Were it necessary I could continue to enthuse over my new receiver, but it is not. Readers know from previous sets of my designs that I do not overstate the case. Peroration will not compensate for lack of performance, nor will rhetoric counter-balance lack of reception. The Record All-wave Three literally speaks for itself. After building and a preliminary test you will confirm my claims and find that, if anything, the set is better than I say.

Save 5/- On the Kit

In order to encourage the reader who has not yet built an all-wave set, as well as making a gesture to those many thousands of loyal regular

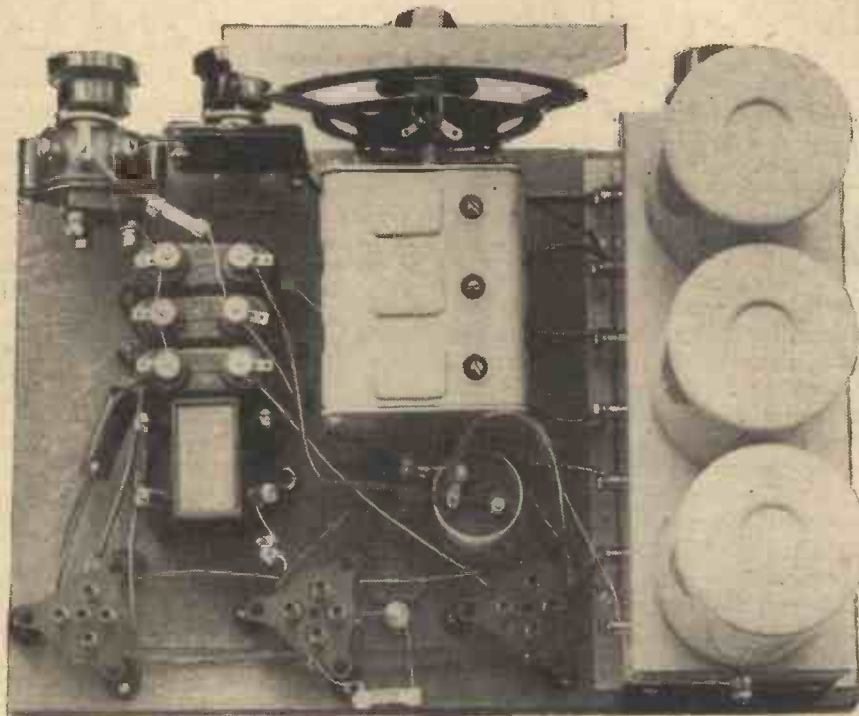

Top view of the Record All-wave Three. Only a few wires are used.

gestion in the ether, with the inevitable result that listening on that wave-band becomes less pleasurable and selectivity goes by the board. With a motor-car you thus seek the by-ways and find that the most pleasant journeys are those off the beaten track.

In no other way can you account for the enormous—almost staggering—interest in short-wave receivers, and if I may continue my simile you will find amongst the short-wave transmissions an enormous store of first-class entertainment upon which you can draw *ad lib.* at any hour of the day or night. It is no longer necessary, of course, to sit up until the small hours of the morning endeavouring to coax squawky transmissions from a few amateurs radiating on about 3 watts. The amateurs

Up-to-date Design

I do not say that sets which do not cover the short-wave band are out of date, but they will rapidly tend to become so. The Record is an up-to-the-minute receiver which introduces you to that fascinating band below 100 metres. To listen in to the short-wave programme on the "Record" is almost equivalent in exhilaration to being transported to a land of strange delights. There is more entertainment and greater variety; certainly more interest. You will not use the short waves as a background to trifling conversation. You will *want* to listen in the best interpretation of that term.

Readers Demand Baseboards

The demand for all-wave receivers among home constructors has been

Superb Reception on All Waves!

readers, I have persuaded Messrs. Peto-Scott, Co., Ltd., to supply the kit at a specially reduced price and you will find that by doing so you will

parts, and to whom this offer will not, therefore, apply.

I have also satisfied myself that the necessary components are avail-

able and ready for immediate delivery.

The Circuit

The circuit is reproduced on page 195 and it will be seen that although a "straight three" arrangement is employed there are one or two points of interest. First, in regard to the coils, it will be noted that the short-wave and normal broadcast units are separated, a complete change-over being effected by the self-contained switch. This arrangement is, of course, preferable to the method where all coils are connected in series, and gives much better results. A further point of interest regarding the tuned circuits is that in the detector grid circuit a small capacity tuning condenser is employed on short waves, and the standard capacity on the broadcast wavebands. This is carried out by using a three-gang condenser in which two of the sections have a maximum capacity of .00025 mfd. and one of .0005 mfd. The two smaller sections are wired to contacts on the switch element so that on the broadcast bands the two sections are in parallel, but on

Three-quarter rear view of the Record All-wave Threc.

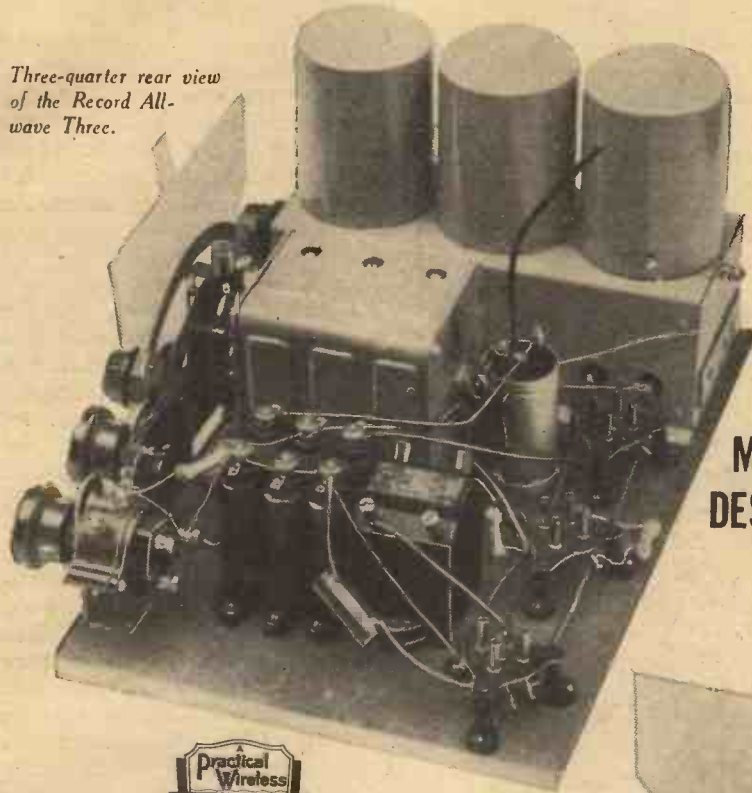

**A
FINE
SET
BY
A
MASTER
DESIGNER**

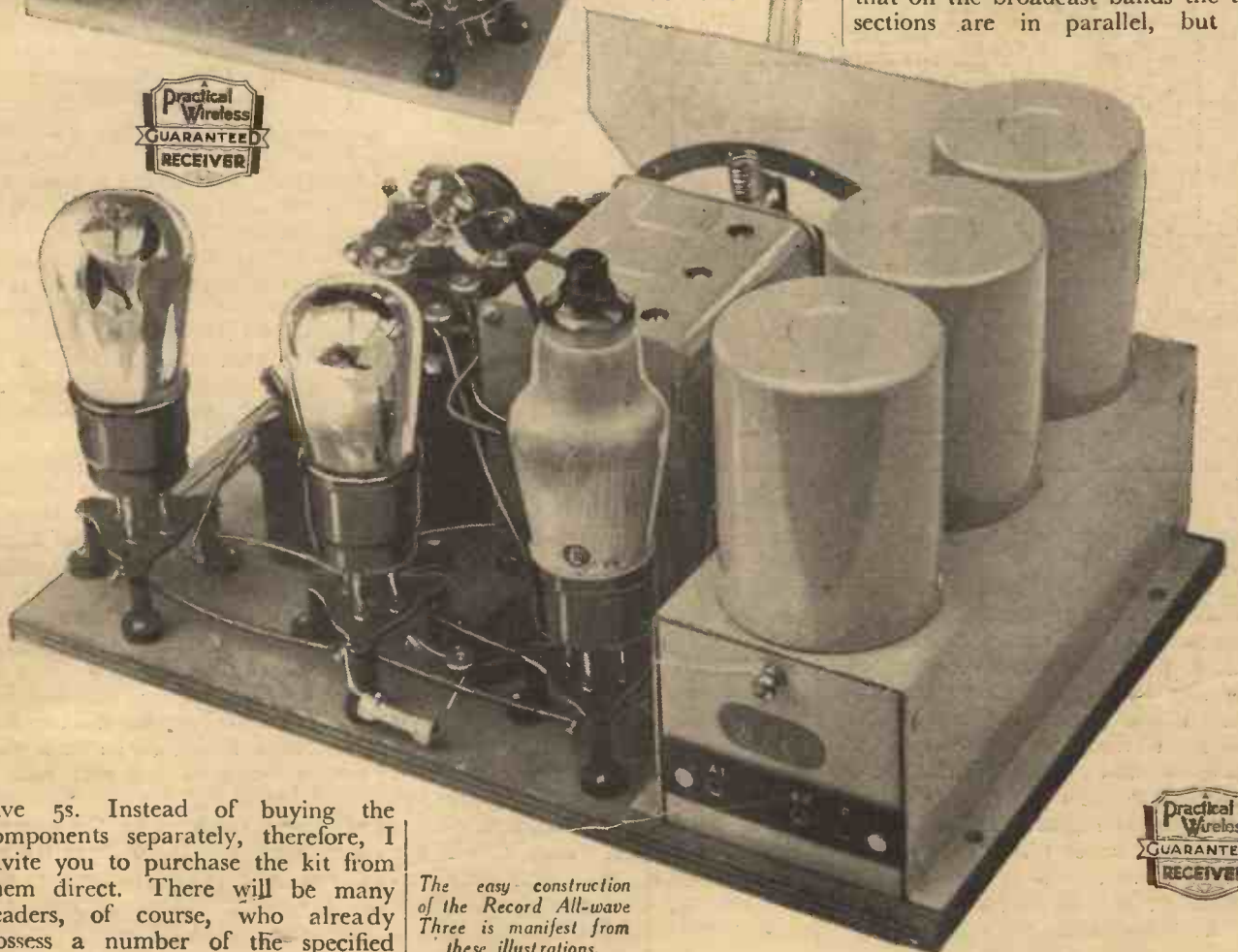

save 5s. Instead of buying the components separately, therefore, I invite you to purchase the kit from them direct. There will be many readers, of course, who already possess a number of the specified

The easy construction of the Record All-wave Threc is manifest from these illustrations.



A Guaranteed Receiver By Our Leading Designer!

short waves only one section is in use and this is connected in parallel in the usual way with the short-wave coil. In the aerial circuit, where the tuning is not so critical on short waves, the addition of a .00005 mfd. trimmer attached to the tuning dial enables the tuning to be satisfactorily adjusted, and the inductances of the coils are arranged so that the correct

been selected ensures good reaction control on the remaining wavebands. It will be noted also that the reaction winding is adjusted for the separate wave ranges, the switch for this being ganged with the remaining wave-change switch elements. The L.F. transformer is direct fed, and the H.T. supply for the detector valve, as well as for the screen of the H.F.

ordinary screw holes so that they may be attached to the baseboard in the simplest possible manner, and no drilling or other labour is involved. The layout provides for short and efficient wiring, and the only point to be emphasised is that each part must be placed on the baseboard in a definite order, otherwise it will be found difficult, if not impossible, to place in position certain of the connecting wires. This order will be explained in the Wiring Instructions which follow.

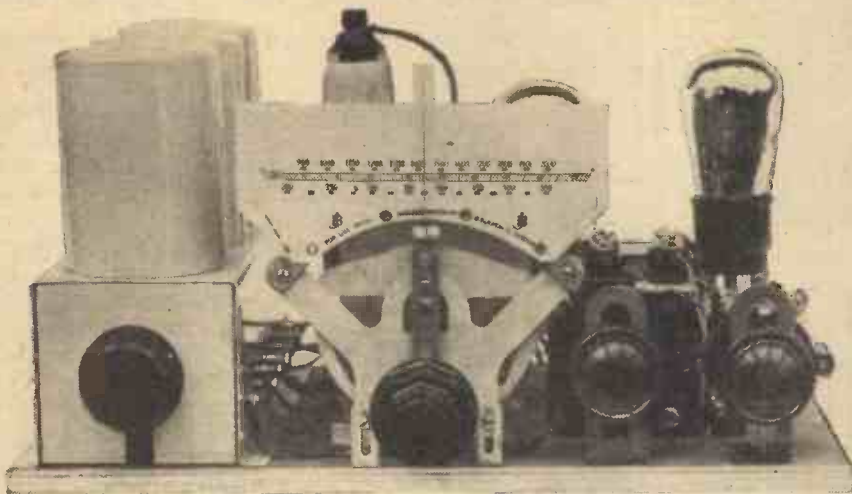

Front view of the Record All-wave Three.

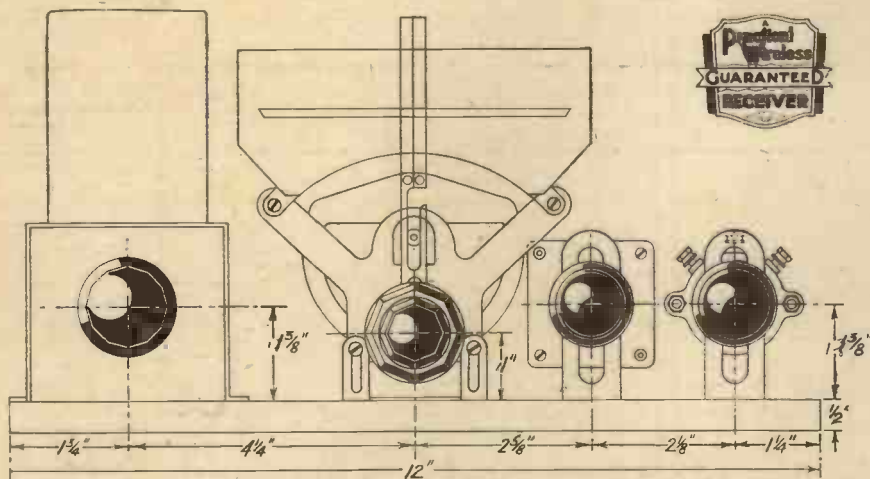

This diagram will enable you to drill the front of the cabinet accurately.

waveband is covered with the .0005 mfd. condenser.

The first valve is a variable- μ H.F. pentode, adjustment of bias by means of a panel-controlled potentiometer providing a control of volume or signal strength. The parallel-fed tuned anode coupling is employed between the first valve and the detector, and this valve is transformer coupled to the output pentode. Instead of using an H.F. choke for reaction purposes a resistor is employed, and this gives a much smoother control of reaction on the short waves, and the value which has

valve, is arranged with a separate lead so that the optimum working conditions may be found under all circumstances.

The Layout

In order to cater for the beginner, this particular receiver has been assembled on a flat baseboard, and the components chosen are provided with terminal connecting points, to which the battery and loudspeaker leads are joined. This avoids the necessity of separate terminals and saves expense. Furthermore, all of the components are provided with

Building the Receiver

To build the receiver, therefore, the following procedure should be adhered to. First, obtain a piece of plywood 12in. by 8in., with a thickness of about $\frac{3}{16}$ in. This may be obtained with the kit of parts from Messrs. Peto-Scott or purchased locally, and will cost only a few pence. Place this beneath the free blueprint which is included in this issue and when it is correctly laid beneath the baseboard plan prick through all the screw holes with a sharp-pointed instrument. Even a sharp pencil will suffice for this. When this has been done, remove the blueprint and screw in position the three valveholders, loosening the screws attached to the lower portion of the valve legs before doing so. Make quite certain that they are in the correct order and arranged in the correct position so far as concerns the grid and anode sockets. Now cut off a length of the connecting wire sufficient to pass from the first to the third valve and cut off two short lengths of insulated sleeving which will just reach from the filament socket on the centre valveholder to the valveholders on each side, and then thread the wire through the centre valveholder filament terminal, slip over the two pieces of sleeving (one on each side) and anchor the ends in the end filament sockets. Carry out the same procedure on the other side of the valveholders, and the filament circuits will be completed.

Wiring

Next screw down the grid condenser, C8 (.0001 mfd.), and attach to the terminal nearest the grid socket of the detector valve a short length of wire and one end of the grid-leak, R.2 (2 megohms). Attach the other end of the grid-leak to the rear socket of the detector filament circuit, and push the end of the wire attached to

Even a Beginner Can Make It!

the grid condenser through the leg of the detector grid. Tighten up the locking screws on the valveholder legs as the wires are placed in position in view of the difficulty of obtaining access to them after the receiver is completed. Next screw down the small base of the All-wave H.F. choke, and then mount the three 1 mfd. fixed condensers. Connect the three right-hand terminals on these (viewing the receiver from the front or control position), using bare wire for the purpose. Next connect a wire from the normal anode terminal on V1 (this is, of course, the screening-grid terminal) to the first fixed condenser, and then attach the .0002 mfd. condenser (C7) to one terminal on the H.F. choke and attach a short bare wire to the other terminal on the condenser. Place the choke in the base which is already screwed to the baseboard and attach the bare wire on C7 to the vacant terminal on C8, but do not attach the terminal head of the latter condenser as a further wire has to be placed on this point at a later stage when the coil unit is placed into position.

Wiring the Coil Unit

Attach lengths of wire to terminals 4, 5, 6, and 7 on the coil unit and place the latter in its position, cutting off the wires so that they will just reach

to the respective connecting points as shown on the blueprint. Then cut off lengths of insulated sleeving and slip over each of these wires. Push the end of the short wire on terminal

LIST OF COMPONENTS FOR F. J. CAMM'S RECORD ALL-WAVE THREE.

1 All-wave Coil Unit	B.T.S.	25s. 0d.
1 Three-gang condenser, Type K (.00025+.00025+.0005 mfd.) (C1, C3, C4)	J.B.	15s. 0d.
1 Slow-motion Drive (type 2135) including .00005 mfd. trimmer (C2)	J.B.	6s. 6d.
1 .0005 mfd. Reaction condenser (C5)	Graham Farish	2s. 0d.
6 Fixed Condensers:		
Three .1 mfd. type B.B. (C9, C10, C11)	Dubilier	3s. 0d.
One .005 mfd. type 4421E (C12)		1s. 0d.
One .0001 mfd. type 670 (C8)		1s. 0d.
One .0002 mfd. type 670 (C7)		1s. 0d.
3 Half-watt resistors:		
One 15,000 (R.3)	Bulgin	6d.
One 50,000 (R.1)		6d.
One 2 megohm (R.2)		6d.
1 Volume control potentiometer with switch, 50,000 ohms type VM.36 (R.4)	Bulgin	5s. 6d.
1 All-wave H.F. choke, type H.F.15	Bulgin	5s. 0d.
1 L.F. transformer, ratio 3.5 to 1, type Niclet	Varley	7s. 6d.
2 Component-mounting brackets	Peto Scott	8d.
3 Baseboard-mounting Short-wave valveholders, two 4-pin and one 5-pin (type V8)	Clix	5s. 6d.
7 Bow-spring wander-plugs:		
H.T.—H.T.1, H.T.2, H.T.3, G.B.—1, G.B.—2	Belling Lee	10½d.
2 Spades, L.T.—and L.T.—	Belling Lee	4d.
1 Wooden baseboard, 12in. by 8in. (Metaplex).		
23 No. 3 ¼ in. round-head screws.		
8 No. 3 ¼ in. ditto.		
2 No. 4 ¼ in. ditto.		
2 Lengths insulated sleeving.		
Quantity of tinned copper wire or insulated connecting wire.		

ACCESSORIES.

Three valves, 210VPT, 210HF and 220 HPT	Cossor.
One W.B. Sientorian Speaker	Whiteley Electrical.
One 120 volt Drydex Super-Life H.T. battery	Drydex.
One 9 volt G.B. battery, Type H.1001	Drydex.
One 2 volt L.T. accumulator, Type DMG-C	Exide.
One "Record" Cabinet	Peto-Scott.

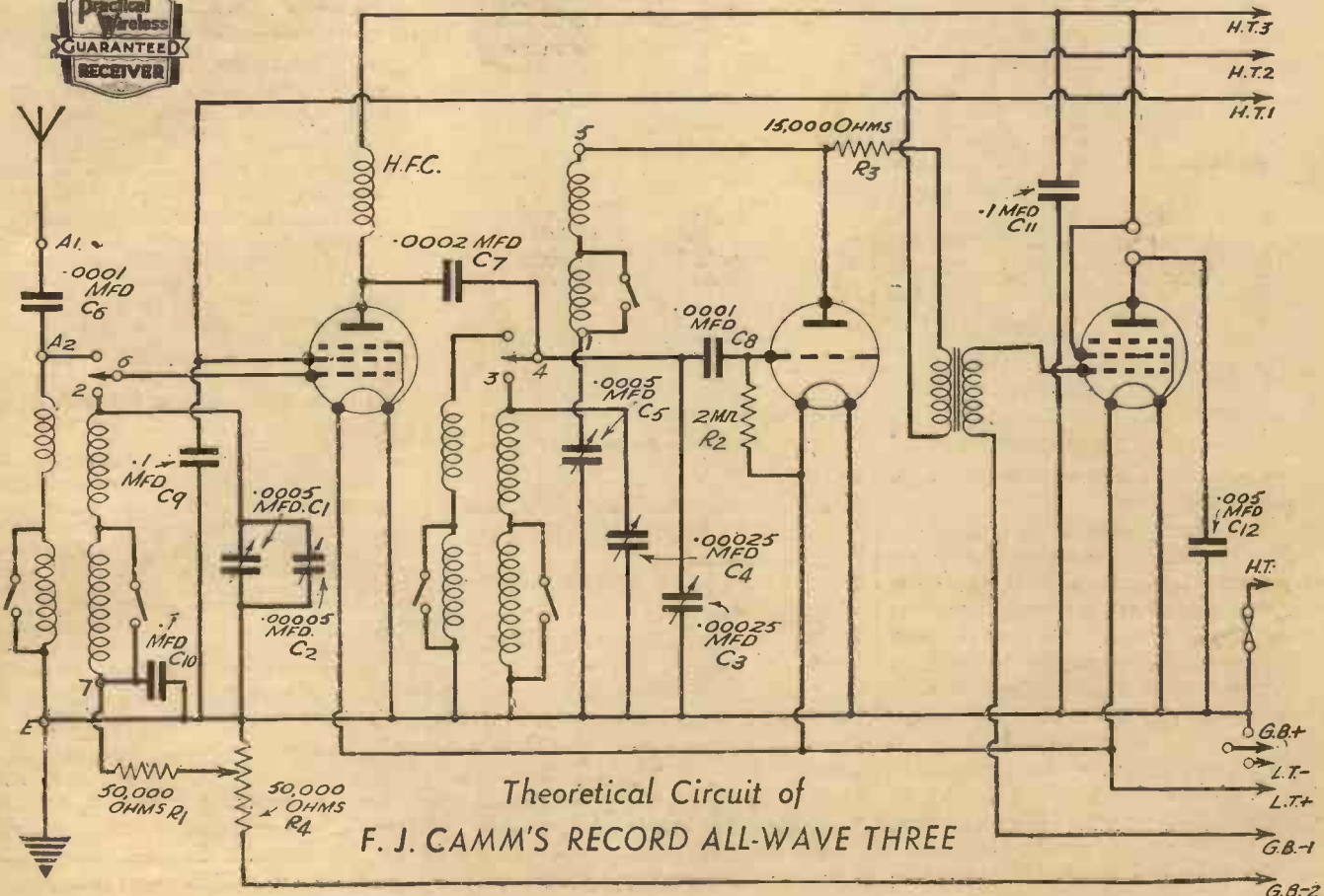

Theoretical Circuit of F. J. CAMM'S RECORD ALL-WAVE THREE

6 through the grid socket on V_1 and screw down the coil unit, afterwards attaching the wires from terminals 4, 5, and 7 to their respective points. Replace the terminal on the grid condenser when the lead from terminal 4 on the coil unit is in position, and then attach one end of the anode resistance R_3 (15,000 ohms) to the detector anode socket, locking this together with the wire from terminal 5 on the coil unit.

The Component Brackets

Screw down the L.F. transformer, making certain that the terminals are in the correct position, and attach the free end of the anode resistance to terminal P on the transformer. Now screw in position the two component-mounting brackets and attach the volume control to the right-hand one. Connect one end of resistance R_1 (50,000 ohms) to the centre terminal on the side of the volume control, and connect the other end of this resistance to the free terminal on condenser C_{10} . Next join the three right-hand terminals on the condensers (which are already connected together) to the left-hand terminal on the side of the volume control and connect this also to one of the terminals on the end of the control. These terminals, incidentally, are connected to the three-point on-off switch, whilst the three terminals on the side of the component are connected to the volume control.

Completing the Wiring

The reaction condenser should now be mounted, and the terminal on this which is joined to the moving plates (this is the terminal which is mounted on the brass strip) should be joined to the left-hand terminal on the volume control which is already joined to the three fixed condensers. Terminal 1 on the coil unit is now joined to the remaining (fixed vane) terminal on the reaction condenser, and the earth side of the three fixed condensers (the three terminals joined together) should then be joined to the nearest valveholder socket on valveholder V_3 . Three short leads should next be joined beneath the screw heads on the lower left-hand side of the gang condenser, and as the screws are rather short the wires should be looped and hammered flat so that they will occupy less room. Attach a length of wire also to the screws which hold in position the screening cover of the ganged condenser, one on the right and one on the left. These may clearly be seen in the blueprint. A square piece of plywood of the same thickness as the baseboard must also be cut to place beneath the ganged

condenser in order to enable the small trimmer to revolve, and this piece of wood should be of the same overall dimensions as the base of the condenser. Screw this to the baseboard, and then attach the ganged condenser by placing wood screws through the fixing holes. Alternatively, the screws supplied by the makers of the condenser may be inserted through the wooden distance-piece before this is screwed to the baseboard, and in that case the heads of the screws will have to be sunk level, and the wood should extend slightly on each side of the condenser so that it may be attached to the baseboard.

Attach the three wires on the left of the condenser to the coil unit terminals 2, 3, and 4, push on the



THE SIGN OF SERVICE—

Every "Practical and Amateur Wireless" Receiver is Guaranteed to Function in the Manner Claimed

—AND SATISFACTION



tuning-dial and lock this in position, making certain that the pointer is set to minimum, whilst the condenser spindle is turned as far as possible to the left. The short lead already attached by the makers of the condenser to the trimming condenser should be taken over and connected to the terminal No. 2 on the coil unit. It now only remains to attach the battery and loudspeaker leads as indicated on the blueprint and the receiver is ready for test.

A FINE BOOK FOR THE BEGINNER!

AND A USEFUL PRESENT

EVERYMAN'S WIRELESS BOOK

(2nd Edition)

By

F. J. CAMM

3/6 or 3/10 by post from Geo. Newnes, Ltd., 8-11 Southampton Street, Strand, London, W.C.2.

PRACTICAL PARAGRAPHS

A Cossor Circuit Innovation

THE three-valve battery and mains short-wave receivers recently introduced by A. C. Cossor have a most interesting circuit innovation. On medium and long waves, the receiver is perfectly straight, but by use of a special valve it automatically becomes a superhet on short waves. In the case of a battery set the special valve is known as 210 S.P.T., and is actually a variable-mu screen pentagrid, and in the mains model the valve is a 41 S.T.H., a variable-mu screened triode-octode.

Visual Tuning Indicator

READERS who have some device, such as the "mystic eye" or "neon" tuning indicator to detect the magnitude of an incoming signal will often find that the device appears to tell lies, inasmuch as stations shown to be weaker sound very much louder than those shown to be stronger. This apparent contradiction is due to the fact that some stations modulate far more deeply than others, which means that a slightly weaker carrier wave will often give a much stronger low-frequency signal. This is particularly noticeable when comparing a German station with a B.B.C. station, as the former often modulate very much more deeply than is customary in this country; also, generally speaking, long-wave stations are modulated much more deeply than medium-wave stations.

Electron Characteristics

MUCH has been said about the speeds at which electrons travel, but reference is seldom made to any other of their characteristics. It is, therefore, of interest to mention the weight of an electron, which, expressed as a fraction of a gramme, is a decimal point followed by twenty-seven noughts, and then finally by the figure 9. An alternative way in which some idea of the minute mass of an electron can be more readily understood is that although an appalling number of electrons are given off by a valve filament every second, the total weight of the uncountable millions of electrons given off by the filament of a power valve in 1,000 hours is only about 300 times the weight of the filament itself.

Properties of Copper

COPPER is used for making connections in electrical equipment because of its low resistance. It has a lower resistance for a given cross-sectional area than any other substance, excepting only platinum and silver, both of which are, of course, far too expensive, although in certain very delicate measuring instruments silver wire is actually used. It is interesting to note that copper is an extremely malleable metal, and the more malleable condition copper is in, the lower also is its resistance.

Loading Small Pentodes

MANY modern straight battery receivers are fitted with a small economy output pentode which is capable of giving not more than 2/300 milliwatts without overloading. The tendency is to turn the volume control up until these unfortunate valves become badly overloaded, with consequent distortion. Some people seem to be under the impression that they are not getting their money's-worth unless they turn the volume control as far as it will go, whereas, of course, on the average set the volume control should not need to be turned much more than half-way on the local.

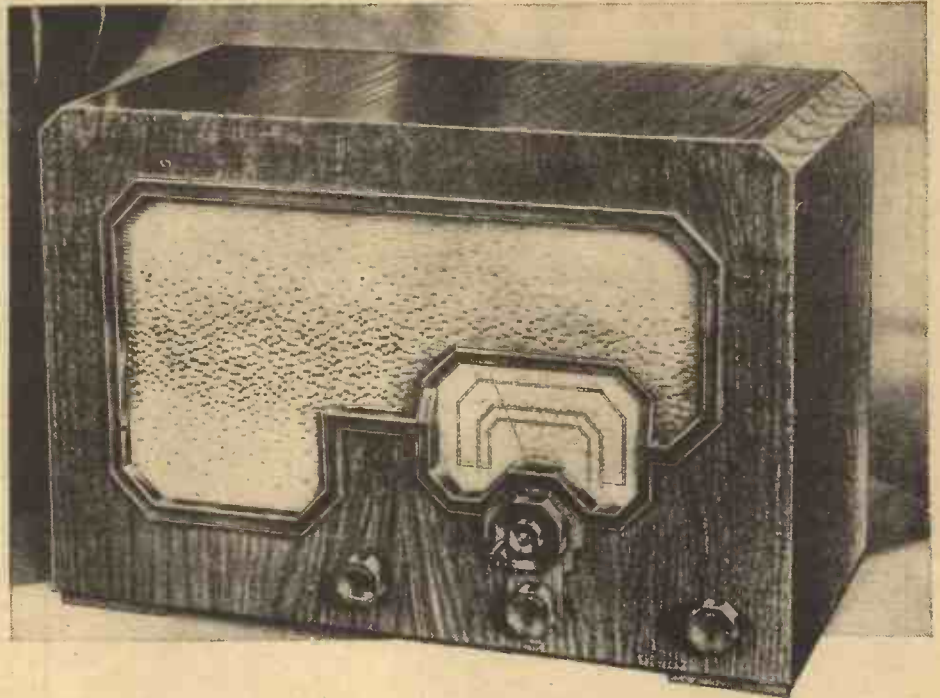

The WORLD at your finger-tips with
COSSOR
ALL-WAVE RECEIVERS

(with Short-Wave Superhet Circuit)
 (Patent applied for)

**COVERS
 3 WAVE BANDS**
 17'25 to 52 metres
 (SUPERHET CIRCUIT)
 200 to 560 metres
 826 to 2000 metres

VARIABLE-MU S.G. CIR-
 CUIT ON MEDIUM & LONG
 WAVES

SUPERHET ON SHORT
 WAVES

SLOW MOTION TUNING
 & REACTION

H.F. PENTODE DETECTOR

PENTODE OUTPUT

MOVING COIL LOUD-
 SPEAKER

HERE is a new interest in wireless—short wave listening. The thrills of long distance reception. America, Australia—the world at your finger tips And the best of the European programmes too! That is what these receivers give you and at a price that you can afford. Hear one of these new Sets at your usual radio dealers.

BATTERY MODEL 3733

With special Pentagrid, H.F. Pen. Det. and Economy Pen. Output Valves. Super-selective coils with special switching, giving variable-mu screened grid circuit on medium and long waves, Superhet circuit on short waves. Special slow motion tuning. Full vision wave-length scale with station names. Precision reaction control and volume control. 8" M.C. Speaker. Superb cabinet with accommodation for batteries.

Hire Purchase Terms :
 12 months : 10/6 deposit and
 12 payments of 13/9.
 18 months : 10/6 deposit and
 18 payments of 10/-.

(less batteries)

£7.15.0

A.C. MAINS MODEL 3783

Generally similar to Battery Model 3733 but with 4 A.C. Mains valves including special Triode Hexode and rectifier and with illuminated dial. For A.C. Mains only. 200/250 volts (adjustable) 40/100 cycles.

Hire Purchase Terms :
 12 months : 17/- deposit and
 12 payments of 16/9.
 18 months : 17/- deposit and
 18 payments of 12/-.

£9.15.0

Prices do not apply in I.F.S.

A. C. COSSOR LTD., Highbury Grove, London, N.5.

F. J. Camm's
ALL WAVE
3

WHY DOES PRACTICAL WIRELESS ADVISE DUBILIER CONDENSERS?



In the All-Wave Three, PRACTICAL WIRELESS has advised you to use three $.1\mu\text{F}$ type BB, one $.005\mu\text{F}$ type 4421/3, one $.0001\mu\text{F}$ type 670 and one $.0002\mu\text{F}$ type 670, Dubilier Condensers. Why have Dubilier condensers been selected in every case? Why? For many reasons, including their extreme reliability, long life, noiselessness, correctly rated values and ease of purchase—but principally because PRACTICAL WIRELESS have a reputation to keep up and wouldn't advise any but the best.

DUBILIER CONDENSERS

DUBILIER CONDENSER CO., (1925) LTD.,
 DUCON WORKS, VICTORIA ROAD, NORTH ACTON, LONDON, W.3.



POLAR CONDENSERS

POLAR "COMPAX"

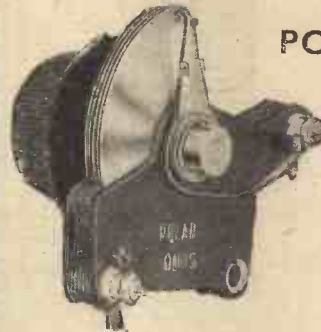

Solid dielectric condenser for tuning or reaction. One hole fixing. Complete with knob.

$.0005, .0003, .00015, .0001, \text{ and } .00005, .00075.$ **2/6**
2/9

POLAR "DIFFERENTIAL"

Solid dielectric. Insulated spindle. Complete with knob.

$.0003, .00015, \text{ and } .0001.$ **3/-**

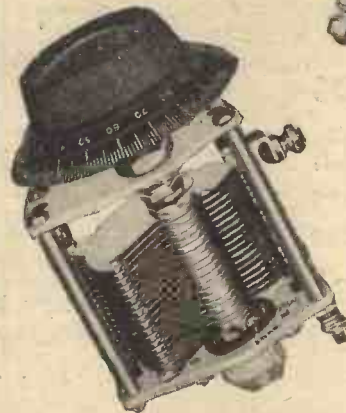

POLAR "No. 2"

Fast and slow motion condenser. Aluminium vanes, with brass pillars. Ball bearings. Robust construction.

$.0005 \text{ and } .0003.$ **6/6**

POLAR TRIMMING CONDENSERS

AIR DIELECTRIC (illustrated)

Steatite base. Soldered brass vanes. Made in capacities of 25, 50, 75, and 100 mmfds, **3/-**

MICA DIELECTRIC

Small solid dielectric trimmer available in the two following capacities.

3/30 mmfds. **1/-** 40/80 mmfds. **1/3**

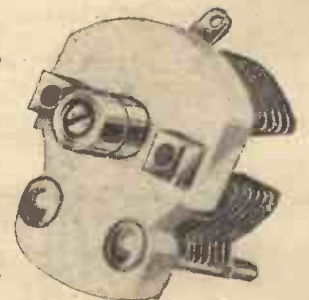

WINGROVE & ROGERS, LTD.,

188/189, STRAND, LONDON, W.C.2.

Phone: Temple Bar 2244.

Works: Old Swan, Liverpool.



On Your Wavelength

By THERMION

The Glorious Fifth

TO celebrate the failure of the plot hatched by Guido Fawkes, who saw no solution to the political mess of this country except to blow up the Houses of Parliament, youth is still encouraged to create a hullabaloo on each fifth of November, to poke crackers through their neighbours' letter-boxes, to tie squibs to cats' tails, and in divers ways to make the night a bedlam. On the fifth of November, therefore, paterfamilias will be so busy attending to the annual conflagration and pyrotechnic display that he will not be listening in. I therefore suggest that all the B.B.C. announcers have an evening off. Just a suggestion for those who have not yet planned their guy: How about making effigies of all the crooners and roasting them to the accompaniment of the catcalls by which they earn their living? You will be bound to draw a crowd, and you will find that all of those who like crooners, and are therefore interested in dancing, will be wagging their bodies in tempo whilst the effigy goes up in flames.

Baseboards

WHILST we are about it we can use this annual occasion to consign to the flames some of the junk which still provides support for spiders, and some of those old sets which ought to have been scrapped a long time ago. I am adding to our local bonfire the few letters I have received, inspired or otherwise, on the question of baseboards, for you will perceive that as we are giving a blueprint of a baseboard receiver in this issue I cannot possibly receive any more letters on the subject.

You will doubtless recollect that I have quoted some of the letters on this subject which I have received recently. One reader has been roused

to contumely, and the very apogee of irascibility because I did not

print his letter *in extenso*. He went to the length of getting all his pals to sign the letter. This leaves me quite cold. I have said many times before that although I suffer criticism gladly I am not going to allow readers to be impertinent. I only publish in full reasoned letters. Such others as are worth quoting have the impertinent parts amended. It is my prerogative to judge what parts I shall, or shall not, quote. I do not like inspired letters. Anyone can get his pals to sign a letter, and it is easy for all of them to say that they are "regular" readers. A sound argument speaks for itself. The policy regarding baseboards or chassis is decided by the Editor, not by me. This irate johnny should have his wrath allayed by the blueprint in this issue. He really owes me an apology.

The Other Side

T. M., of Widnes, sends me a quotation which provides the other side to the argument about jazz. Herewith quotation:

"You people in England, who never before have heard 'Squeeze Me' are in for one of the most exquisite pleasures of your life. Here is a record that is completely successful, completely integrated. Throughout it is soulful and passionate, like the greatest of Negro music, and Louis' playing and singing surpass description.

"Here, even the tune fits into Louis' scheme, and Earl plays in a manner that no other pianist has yet resembled.

"'Once in a while' is the American backing to 'Struttin' With Some Barbecue,' a record which I haven't owned for several years. My vague memory says I used to be nuts about it."

I can't stop anyone liking this sort of music; I can't stop them from

liking songs with misspelt titles, which include such words as gonna, ain't, dog-gone, singin', etc., etc. That, to me, is the language of the gutter.

J. R., of Oxon, asks what I really do like in music. I have stated this many times, but I will repeat it. I like light operatic stuff, including the music of Schubert, Lehar, Jones, Tate, Gilbert and Sullivan, to mention but a few. If I want musical lollipops I prefer something which is tuneful, and I prefer the words to obey the ordinary rules of poetry. I do not take my standard from Tinpan Alley. I am pleased to note that the B.B.C. has lost its jazz-band complex with trumpeters earning £1,000 a year, and singers of scat music making fortunes. No wonder there is social unrest in this country, and a great shortage of skilled labour. One wonders at the sanity of the human race when you observe the thousands of pounds worth of comic-looking brass instruments with knobs and twiddly bits used to produce just a noise, which becomes a pain in the neck. Anyone can conduct such a band. You do not need to know anything of music. Just act like a raving lunatic with a face suffused with an asinine smile to betray the vacant mind and there you are—you are a jazz-band conductor. You will have a large fan mail from silly females, and autograph hunters will besiege the stage door.

Television Reports

I SHOULD be grateful to receive from readers who may have had television receivers installed, reports as to their performance, giving also the distance from London. According to latest information, the optical spectrum theory does not quite fill the bill, for reception has been reported from localities situated 100 miles from the Alexandra Palace. This is all to the good, for it indicates that the radius of reception is not confined to thirty miles as originally stated. It appears that the installation of a

receiver for television is not such a simple matter as with ordinary broadcast receivers. It is necessary to make tests as to the strength of the signal. I am pleased to learn from the companies concerned that they are doing good business in the sale of television receivers. Another firm announces that it will market a receiver—Murphy Radio have designed a cathode-ray television receiver, an interesting point about it being the use of a vision receiver which operates on the single side-band system. It was recently demonstrated at Welwyn Garden City—fifteen miles from Alexandra Palace. It is housed in a vertical cabinet of small size and the equipment includes three separate chassis mounted one above the other. The whole can be withdrawn by unfastening two bolts. The tube is mounted vertically, and protected by a safety glass window. The picture is viewed in an inclined mirror secured to the lid of the cabinet. Sound and vision receivers are of the superhet type, employing a common aerial and oscillator. It is claimed that the single side-band system for the vision receiver permits of a large stage gain with a flat response up to 2 megacycles. A suppressor circuit is employed so that the receiver does not operate until it is exactly in tune, when the sound is heard first, and then the picture appears on the screen. The on-off switch is operated by the lid, and the picture is approximately 9½ in. by 7½ in. It appears on a pale green screen which provides, it is said, a sharper picture. No statement has yet been made as to when the receiver will be put into production.

Licences

THE September licence figures show an increase of 45,000, the actual figure being 45,053, which includes 242 free licences. The approximate totals for licences in force at September 30th were 7,745,000, of which there is a total of 45,400 licences issued free to the blind. This total covers England, Wales, Northern Ireland, and Scotland.

Shortage of Service Engineers

I UNDERSTAND that there is a dearth of Service Engineers, and here is the chance for some of our clever readers to better their position if they are able to comply with the requirements. Readers should have an excellent knowledge of the theory of wireless sets, and be able to handle mains as well as battery receivers. They should know how to track a fault down systematically and quickly. If



Valve-holder Contacts

A PREFECT Three was sent to our laboratory for test last week, the constructor complaining that no signals could be picked up. After the batteries had been connected up it was found that no H.T. current was being taken by the output valve. The valve itself was at once suspected but proved to be quite in order when tested independently. The voltages at the filament and anode sockets of the valve-holder were then checked, and these were also found to be in order. The only component left which could affect the consumption was the valve-holder. Although this seemed perfect and the valve seemed to fit quite rightly in its sockets, it was found that one of the filament pins of the valve was not making contact with the holder socket and therefore no L.T. was being applied to the valve. This was actually the fault of the holder, as several valves that were tried in it produced the same result. After the filament socket had been pinched slightly satisfactory reception was obtained.

L.F. Instability

A PECULIAR form of L.F. instability was experienced in one of our receivers—the £4 Superhet—the other day. When the receiver was tuned to a strong signal a loud whistle could be heard which practically drowned the signal, but when listening to weak stations the quality of reproduction was good, and no whistle could be heard. L.F. instability is often experienced in home-made receivers of the detector-two L.F. type, and is generally due to ineffective decoupling of the valve anode circuits or to the use of a run-down H.T. battery. The £4 Superhet has only one L.F. stage, however, and the battery used was in good condition. Reversal of the leads to the G and GB terminals was first tried, as a reversed winding can cause instability. This alteration did not improve matters, however, and it was eventually found that the whistle was due to interaction between the speaker lead and the detector valve. The lead from the L.S. socket to the output valve passes over the detector valve socket in this set and the constructor had run the lead too near the grid pin of the detector.

you are looking for such a job don't write to me but approach the wireless firms direct.

Interference Suppression

IT is good news that definite steps are to be taken to prevent interference by tackling the matter at the source. According to my information, a law will be passed within the next year or so making illegal the construction, sale, or use of electrical apparatus which is capable of generating interference. This is a step which is long overdue, for I contend that anyone using electrical equipment which causes annoyance to other citizens should be placed in the same category as one who drives a car the exhaust of which makes a fearful noise. Hundreds of motorists have been fined varying amounts for causing less than a tenth of the annoyance which results to-day from the use of a small item, such as a hair dryer or a vacuum cleaner.

What I do want to know is what will happen to existing electrical equipment. I trust that, in time at any rate, it will become compulsory to fit suitable suppressors to every device in use. The cost is rarely great, and it is the duty of every citizen to take every reasonable measure possible to prevent his spoiling the peace and quiet—and private entertainment—of others.

Aerial Controversy

I SEE in a daily paper that a contributor writes bemoaning the fact that unsightly aerials still adorn the suburban garden. This contributor goes on to point out that with the modern receiver just as good results may be obtained with a wire slung up indoors. But this is not strictly true. There is no arrangement which is exactly as good as a properly-erected outdoor aerial. Unfortunately, however, the majority of aerials are not properly erected, but are merely odd lengths of wire slung up anyhow, and it is perfectly true that a well-arranged indoor aerial will be productive of better results than this type of aerial. But there are just as many points to receive attention in an indoor aerial as in an outdoor one, and the general statements must not be taken without qualification. I do not doubt but that many of my readers have tried both aerials and have found which is better, but it is up to each one to adopt the scheme which proves most satisfactory, although I entirely agree that an unsightly aerial should be avoided. We do not, however, require litigation or local by-laws to prevent the listener from erecting the best aerial he can.

SAVE £1 on your RECORD KIT!

● IMMEDIATE DELIVERY — CASH — C.O.D — H.P. ●

CONSTRUCTOR KITS N.T.S. ALL WAVE 3 12-2,000 METRES

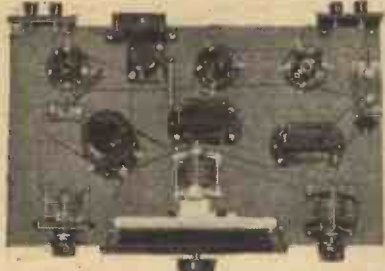

Build a set that will receive the whole world direct, for a very small outlay. Includes everything for immediate assembly: 1 Slow Motion Dial; 3 6-pin Coils, 12/26, 260/516, and 1,000/2,000 metres; 1 6-pin coil base, 3 4-pin base-board mounting valveholders; 7 short-wave H.F. Choke; 3 variable condensers, .0001, .0002, and .00016 MFD.; 2 terminal mounts; 4 terminals; 2 L.F. Transformers; 2 fixed resistances; 3 fixed condensers; 3 component brackets; 1 switch; 1 metal-sprayed baseboard; 1 coil connecting wire; 1 wiring diagram.

5/-
DOWN

N.T.S. SHORT WAVE 2 12-94 METRES



Two-Valve Short-Wave Set of remarkable range that will give you hours of entertainment on the fascinating short-wave Bands. Kit comprises all necessary components, including metal-sprayed baseboard, three variable condensers, .0001, .0002 and .00016 MFD. on/off switch, L.F. Transformer, three baseboard mounting four-pin holders, short-wave H.F. choke, two terminal mounts, four terminals, three fixed condensers, slow-motion drive, grid leak, connecting wire, three 4-pin short-wave coils, 12/26, 22/47, and 41/94 metres, 2 component brackets, and wiring diagram.

2/6
DOWN

N.T.S. ONE-VALVE Short Wave RECEIVER

Complete Kit of parts to build an efficient experimental short-waver covering 12/94 metres. Comprises Metaplex baseboard, variable and fixed condensers, switch, valve and coilholders, H.F. choke, terminals, slow motion drive, 3 short-wave coils, connecting wire, and FULL WIRING DIAGRAM. Less valve. Every part for immediate assembly. Cash or C.O.D. Carriage Paid 19/8.

2/6
DOWN

N.T.S. S. W. ADAPTOR 12-94 METRES



Hear America and all the World DIRECT on your present set, for only 17/6. Complete Kit of parts to build a reliable short-wave adaptor for use with any BATTERY receiver. Kit comprises all parts for instant assembly including metal-sprayed base-board, 2 variable condensers, .00016, .0001 MFD., 2 base-board mounting 4-pin holders, short-wave H.F. choke, grid leak, fixed condenser, adaptor plug terminal mount, two terminals, 3 4-pin plug-in coils, 12/26, 22/47, and 41/94 metres, 1 component bracket, slow-motion drive, trimming condenser, connecting wire and wiring diagram. Built in one evening.

2/6
DOWN

Cash or C.O.D. Carriage Paid 17/6 or 2/6 down and 7 monthly payments of 2/6.

RECORD ALL WAVE 3 KIT DESCRIBED IN THIS ISSUE

EVERY PART GUARANTEED
MATCHED — PROVED — TESTED

KIT "A" CASH OR C.O.D. CARRIAGE PAID 63/-

Comprising N.T.S. Kit of matched components, including exclusively specified B.T.S. ALL WAVE COIL UNIT, J.B. 3-GANG TUNING CONDENSER and DRIVE and PETO-SCOTT METAPLEX BASEBOARD, less valves, cabinet and speaker.

5/-
DOWN

Balance in 11 monthly payments of 5/9.

THESE ARE THE ITEMS IN KIT "A"

Any part available separately. Orders over 5/- sent carriage paid. C.O.D. extra.

	£	s.	d.
1 B.T.S. All-wave Coil Unit Type 4BTU	1	5	0
1 J.B. 3-gang condenser, type K	15	0	0
1 PETO-SCOTT Metaplex baseboard, 12" x 8" and plywood condenser support	1	8	0
1 J.B. slow-motion drive	6	6	0
1 N.T.S. .0005 mfd. reaction condenser	2	0	0
6 N.T.S. fixed condensers	7	4	0
3 N.T.S. 1-watt resistors	9	0	0
1 N.T.S. 50,000 ohm potentiometer with switch	4	6	0
1 N.T.S. all-wave H.F. choke	4	6	0
1 N.T.S. L.F. transformer	4	6	0
2 PETO-SCOTT component-mounting brackets	8	0	0
3 Low-loss valveholders with mounting pillars	2	6	0
7 Wanderplugs	10	4	0
2 Spades terminals	1	0	0
Connecting wire, screws, flex	1	0	0
KIT "A" CASH OR C.O.D. CARRIAGE PAID	£3	3	6
Set of 3 Specified Valves	£1	6	9

KIT "B" As for Kit "A" but including 3 specified valves, less cabinet and speaker. Cash or C.O.D. Carriage Paid, £4/9/6, or 12 monthly payments of 8/9.

KIT "C" As for Kit "A" but including valves and specified cabinet, less speaker. Cash or C.O.D. Carriage Paid, £6/4/9, or 12 monthly payments of 11/6.

N.T.S. MARVEL S.G.3 KIT

Newly-developed circuit, modern to the minute and using tested and matched components. The Kit includes 2-gang air-spaced condenser of advanced design; Slow Motion Dial; wave-wound coils on bakelized formers; super L.F. Transformer; solid electric reaction condenser; complete with ready-drilled chassis and all necessary valveholders, small condensers and resistances. (Blueprint showing How to Build the Marvel S.G.3 supplied FREE with each Kit.)



3/6
DOWN

Cash or C.O.D. Carriage Paid £1 : 12 : 6 or 3/6 down and 8 monthly payments of 4/-.

N.T.S. S.G.3 CHASSIS AT LESS THAN COST PRICE

Each Chassis brand new and tested on British and Foreign Broadcasts before dispatched to you

CIRCUIT COMPRISES:
Screened-Grid H.F.; Detector and Pentode Output Valves. Screened wave-wound coils, 2-Gang Air Dielectric Condenser. Metal Chassis. Only 9 m.a. H.T. consumption. Illuminated and Wave-length Calibrated Dial. Wave range 200-2,100 metres.

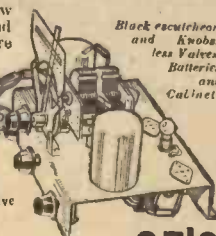

LIST PRICE £4 : 4 : 0 OUR PRICE 27/6
Cash or C.O.D. Carriage Paid.

COMPLETE RECEIVERS

BELMONT AC/DC 4

LIST PRICE
£7 / 10 / 0

Bargain Price
£6 / 6 / 0

5/- and 18 monthly payments of 7/9.



MODEL 444

- For A.C. or D.C. Mains, 200-260 v.
- Wavelengths 195-580 and 800-2,100 metres.
- Illuminated airplane dial.
- Moving Coil Speaker.
- NO EARTH REQUIRED.

2 MORE BELMONT BARGAINS.

5-V. SUPERHET A.C./D.C. TRANSPORTABLE
195-2,100 metres. Requires earth or fixed aerial. Excellent performance. List Price £9/19/6. Bargain Price £8/19/6, or 7/6 down and 18 monthly payments of 11/-.

5-V SUPERHET A.C. ALL-WAVE RECEIVER
Wonderfully efficient reception from every corner of the World. 16-2,140 metres. List Price £11/11/0. Bargain Price £9/9/0, or 7/6 down and 18 monthly payments of 11/9.

McMICHAEL "LODEX"

5-VALVE BATTERY

7/6
DOWN



and 18 monthly payments of 9/-.

LIST PRICE 16⁹/₆ OUR PRICE 7⁶/₆

- 2 H.F. Stages, Detector, Driver and Class B Output.
- Moving Coil Speaker.
- Exceptional degree of selectivity.
- Long range.
- FINE VOLUME.
- Complete with all valves, H.T. battery and accumulator.
- Ready to play.

P.M.M.C. SPEAKER BARGAIN AT 7/6

BRAND NEW Permanent Magnet Moving-Coil Speakers at less than cost. 6in. Cone. Large magnet and complete with input transformer suitable for Power, Super-Power or Pentode. State which type required when ordering. Cash or C.O.D. 7/6. (Carriage 6d extra.)

POST THIS COUPON

New Times Sales Co

56 (P.W. 20), LUDGATE HILL, LONDON, E.C.4
Please send me CASH/C.O.D./H.P.:

NAME.....
ADDRESS.....

EST. 1924



We are still pioneering. We flatter ourselves that these ganged tuning units of ours are a good deal ahead of their time. Incorporate one of these units in your own set. We don't say that you will be "amazed" or "staggered" at the result. But we do say that you will be most agreeably surprised.

For your especial benefit, we have recently published four brand new circuit blueprints, which are giving excellent results with our new ganged units. No. 1 (BP. 111) Mains Superhet for 110 k.c., No. 2 (BP. 112) Battery Superhet for 465 k.c., No. 3 (BP. 113) Three-valve mains receiver with band-pass tuners. No. 4 (BP. 114) Screened-grid Battery Three with Pentode. You can have one of these blueprints (and they're really worth having) for 6d. (BP. 111, BP. 112, BP. 113), or the BP. 114 for 3d. The postage is free.

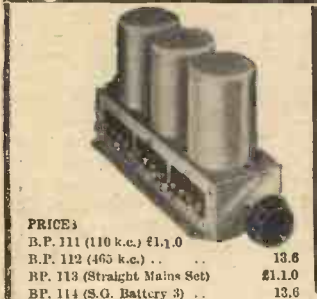

PRICES:
B.P. 111 (110 k.c.) £1.1.0
B.P. 112 (465 k.c.) .. 13.6
BP. 113 (Straight Mains Set) £1.1.0
BP. 114 (S.G. Battery 3) .. 13.6

Reduced facsimile of Blueprints

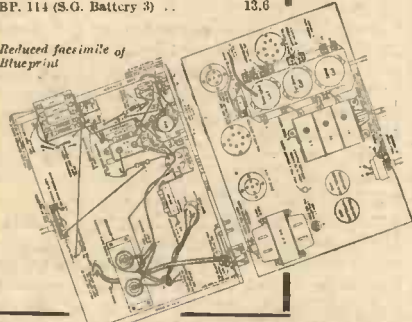

— For here comes
Varley

OLIVER PELL CONTROL, LTD., Bloomfield Rd., Woolwich, S.E.18. Woolwich 2345

EASY TERMS

1936-7 RADIO

FOR MORE THAN TEN YEARS we have SPECIALISED in the supply of all good quality RADIO SETS, COMPONENTS, VALVES and ACCESSORIES. SEND LIST OF YOUR REQUIREMENTS and we will supply keen quotation by return.

W.B. Stentorian and all well-known Loud-Speaker Units

supplied on the lowest terms. CABINET and EXTENSION SPEAKERS on similar terms. FULL LIST ON REQUEST.

New B.T.H. Piezo-Electric Pick-up (in stock)

Cash Price 35/-; or 4/6 with order and 8 monthly payments of 4/3.

Valves, etc.

Battery and mains valves, all ring brands supplied on the best terms. Prompt delivery. Please write for quotation for Valves.

★ **McCarthy Chassis** ★

The remarkable New Model RF6AW ALL-WAVE CHASSIS—Cash price £8.10.0, or delivered for First Payment, £1.7.0, and 10 monthly payments of 16/-. Complete Price List available on request.

Latest Pick-ups and Gramo-motors

All the newest products of well-known Makers supplied on the best of Easy Terms.

'Avomitor' Testing Meter

A most valuable instrument for tracing faults, etc., £2 cash, or 4/- with order, and 10 monthly payments of 4/-.

Eliminators

All well-known makes supplied for FIRST PAYMENT of 5/-.

WE GUARANTEE SATISFACTION TO EVERY CUSTOMER. PROMPT DELIVERY. CASH or C.O.D. ORDERS SENT BY RETURN.

Estd. 1925 THE NATIONAL 1977

LONDON RADIO SUPPLY COMPANY

11 OAT LANE NOBLE STREET LONDON E.C.2

F. J. CAMM'S
"Record" ALL-WAVE 3

Components specified by the designer FOR A GOOD JOB WELL DONE
7 "Bowspring" Wander Plugs.
H.T.-; H.T.1; H.T.2; H.T.3: G.B.+; G.B.-1; G.B.-2. 7 @ 1½d. --- 10½d.

2 Spade Terminals. L.T.+; L.T.-. 2 @ 2d. --- 4d.
1/2@d.



Spade Terminals
Unique spring construction. Will chip on to any terminal on wire and stem or wire and stay put. Connecting up becomes a one hand job. Metal parts heavily lead coated to prevent corrosion if used on accumulators.

No. 1025. Price each, 2d.
As above but with 1" handle. No. 1248. Price each, 3d.
For heavy duty or to take serial wire 11" bakelite handle No. 1247. Price each, 6d.



Bowspring Wander Plugs

The next best thing to the drawn wire. three prong type, and the best of its class. Extra resilience from the prongs. Well finished. Strong spring and wide self adjustment. 12 Standard indications.

No. 1112. Casein Cap. Price each, 1½d.
No. 1289. Bakelite Cap. Price each, 1½d.

Write for Complete Catalogues. "Radio Spares and Connections"; the pocket reference; FREE. "Radio and Electrical Accessories"; 46-pp. book containing 150 illustrations, including 75 blue prints of curves, diagrams, circuits, constructional details and specification of every part. Of exceptional value to constructors. Price 8d., post free.

BELLING-LEE FOR EVERY RADIO CONNECTION

BELLING & LEE, LTD., Enfield, Middx.
Cambridge Arterial Road, Enfield, Middx.
Please send copy of free Catalogue; "Radio Spares and Connections." Please find enclosed 8d. remittance for post free copy of "Radio and Electrical Accessories."

STRIKE OUT ITEM NOT REQUIRED

Name

Address

Pr. W. 31.10.36

Send this coupon

CHARGE YOUR OWN BATTERY!

This new all-metal "TOM THUMB" battery charger will charge 2 volt low-tension batteries at 1/2 amp. This apparatus incorporates a METAL RECTIFIER, is supplied complete with mains plug and lead, and will give many years of useful service.

NO VALVE REPLACEMENTS

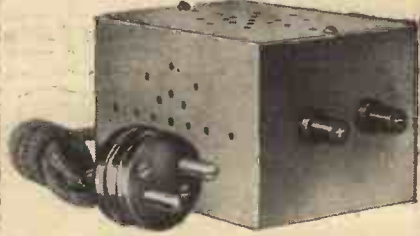

Send NOW for details of this amazing midjet low-tension battery charger. Size 3½" x 2½" x 2½"

12/6

M
Address

PTT
F. C. HEYBERD & Co. 10, FINSBURY STREET, LONDON - E.C.2

BREAKTHROUGH: WHAT IT IS AND HOW TO CURE IT

Trouble is Often Experienced from Signals of One Wavelength Which are Received as a background to Other Signals. The Causes and Cures of This Type of Interference are Given in This Article

By W. J. DELANEY

A COMMON trouble which is experienced by many listeners is that when tuning on one waveband, signals of a wavelength which is not covered by the tuning coil in circuit can be heard. It is found in most cases, however, that this trouble only arises when a very powerful station is situated fairly close to the receiver, and the general term applied to this form of interference is "breakthrough." An example is to be found in many Midland districts where the high-powered long-wave transmitter at Droitwich can be heard on

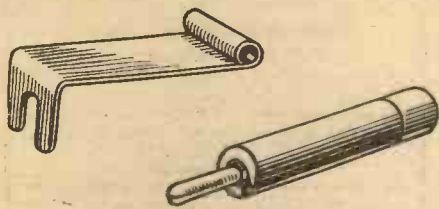

Fig. 1.—This is the Belling-Lee television interference choke.

many receivers as a background to all of the medium-wave signals. A more recent example is found in the Northern districts of London, where the television signals from the Alexandra Palace (both sound and vision) are superimposed upon the ordinary medium- and long-wave broadcast bands. In many coastal districts a similar difficulty is experienced with morse transmissions, but in every case it will be found that there is a preventive for this form of interference.

The causes of the superimposition of the signal may not always be the same, although it is generally found that the trouble is only caused by a near-by high-powered transmitter. It might be thought that a selective tuner would overcome the difficulty, but this is not always the case. For instance, it is often found that even when a superhet receiver is in use a nearby transmitter will cause the trouble, although in this case, owing to the fact that the signal frequency is changed before being fed through the successive stages, the signal cannot be heard in its original form, and it then appears as a whistle, to which the term second-channel interference is often applied.

Causes of Breakthrough

In general, there will be only two causes of breakthrough. Either the signal causing the trouble is of such a frequency that the aerial-earth system resonates at that frequency, or the signal is so powerful that it is picked up on the actual circuit wiring. Obviously, therefore, the cure should be to modify the aerial circuit and/or screen the entire receiver, and in practice this is found to be the case. The aerial-earth system includes the aerial coil, and in many circuits this consists of a small coil coupled to the first grid coil. A modification in the resonant frequency of the aerial-earth system may often be carried out satisfactorily by means of a series-aerial condenser, but this does not always cover a sufficiently large range to prove effective.

For instance, some of the older types of tuner incorporate only a single coil in the aerial circuit, the grid coil covering the medium and long waves by means of the standard wave-change switch, Fig. 3. In some cases it is found that this single aerial coupling coil is of such a size that it forms, with the aerial and earth wires, a "tuned" circuit of the wavelength of a powerful station, and thus causes breakthrough. To modify the coil is not a simple matter, but the addition of a loading coil between the aerial lead and the aerial terminal, or between the earth terminal and the earth lead, will often prove successful. Fig. 4.

Aerial Chokes

Where a receiver is designed only as a single- or two-station receiver, an H.F. choke may be found a satisfactory solution if included in the aerial lead, although the choice of the choke may not prove a simple matter. In the case of the television transmissions, however, an ultra-short-wave choke is definitely effective, provided

Fig. 2.—An H.F. choke in the form of a valve adapter to facilitate inclusion in circuit. This is the Bulgin U.S.W. suppressor choke.

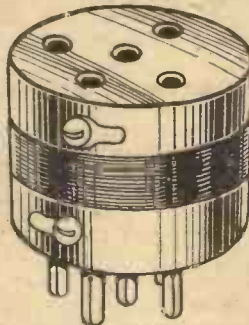

that the receiver is designed to cover only the medium- and long-wave ranges. Any commercial choke may be used in this case, but a special component is now obtainable from Messrs. Belling-Lee, and is illustrated in Fig. 1. This is wound on a former to resemble a wander-plug and facilitates connection to the aerial terminal. No by-pass condenser or other addition is required. A modification of this arrangement is to include the choke between the

aerial circuit and the first grid, although in one or two receivers this has not been found quite so satisfactory as the direct aerial connection. In the majority of standard simple receivers, such as "straight threes" (S.G., Detector, and L.F. circuits), the arrangement is quite effective, however, and a suitable choke is manufactured by Messrs. Bulgin. This component, as may be seen from Fig. 2, is wound on a valve adapter, and this is inserted between the valve and the valveholder, automatically including the choke in the grid circuit. In certain receivers, where the first stage is a reacting detector valve, however, it may be found that reaction effects are rather erratic with this arrangement, but it is possible to incorporate it by modifying the reaction circuit. The capacity of the anode by-pass condenser should be lowered, and the reaction circuit leads should be kept as short as possible.

For long-wave breakthrough the aerial circuit should be reduced, unless it so happens that the resonant frequency occurs at a harmonic of the long-wave station. If the aerial coil is of the type designed to cover both medium and long waves without a switch, or if a switch contact is provided but not used, the expedient of shorting part of the coil should be tried when receiving medium-wave stations Fig. 4.

Screening the Receiver

Where a trial of the above schemes is found to be ineffective it may be taken that the trouble is due to direct pick-up on the receiver wiring, and then the only cure is to screen the receiver entirely. It is not necessary, however, to enclose the receiver in a metal box to do this, although no doubt the screening would be more effective if a complete screen were used. Messrs. Wright and Wearo and Messrs. Stratton both supply screening boxes in which small receivers may be built, and the Wearite unit may be used for individual sections of a receiver, enclosing each stage in a separate box. A simpler scheme is to adopt the standard method of building the receiver, but to line the containing cabinet with thin aluminium or copper foil. The foil must be affixed to the bottom of the cabinet as

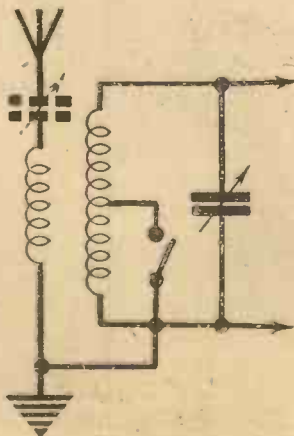
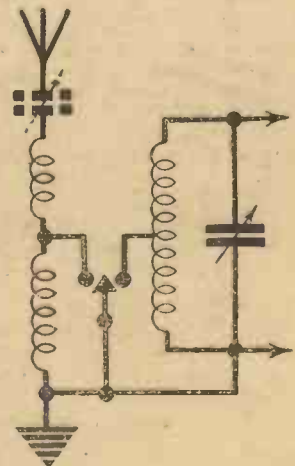

Fig. 3 (left).—A simple circuit may prove difficult to modify to avoid breakthrough although an aerial condenser is very useful. Fig. 4 (right).—Separate coils for medium and long waves will often prove most satisfactory.



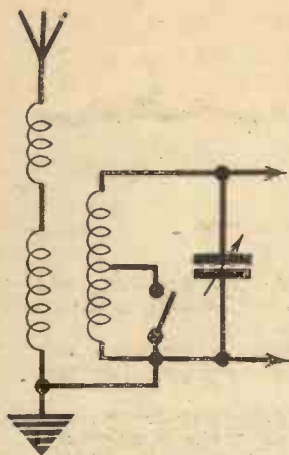
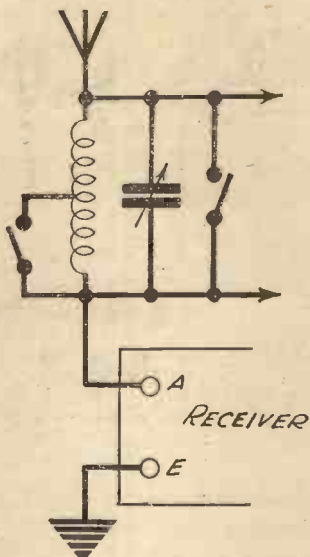

Fig. 5 (left).—A choke in the aerial lead will avoid certain types of breakthrough, although the best circuit arrangement for this type of interference is a wave-trap as shown (Fig. 6) on the right.



well as the sides and top, and all joints must be electrically sound. It is not sufficient merely to overlap the joints. They should be soldered, and an earth wire must be attached at a convenient point for subsequent connection to the earth terminal.

If the cabinet is of the type having a lid which must be removed or lifted frequently, the joint between lid and sides should be made electrically perfect by using thin copper gauze doubled and fixed in such a manner that one portion fits inside the other. Many modern commercial receivers are now built with an all-metal chassis which is practically a complete box, the bottom being almost enclosed by means of metal screens to which certain components are affixed. This, in conjunction with the totally screened valves, coils and condensers, ensures complete absence of breakthrough.

Wave-traps

In the unlikely event of any of the above suggestions proving ineffective, or as an alternative which is simpler to carry out but is more difficult to operate in practice, the old-fashioned wave-trap may be used. This consists simply of a tuned circuit connected between the aerial lead and the aerial terminal. For the elimination of medium-wave breakthrough a medium-wave coil tuned by a .0005 mfd condenser may be used, and for long waves the standard long-wave coil. Thus, a standard dual-range broadcast coil with a parallel-tuning condenser is required. A modern iron-coil component will give a sharper cut-off and prevent the elimination of more than one station, when it is desired to receive a

station on a wavelength closely adjacent to that which it is desired to eliminate. This coil and condenser assembly should be enclosed in a metal box which is earthed.

The same arrangement forms an effective whistle eliminator for second-channel interference, but it must be remembered that when the interfering station is required, the wave-trap must be short-circuited, and therefore, a shorting switch must also be included in the wave-trap circuit, unless you are prepared to readjust the condenser for each station you desire to hear. Obviously if the wave-trap condenser is simply turned to enable you to hear a station, it may happen that the new setting will correspond to another station which you may be desirous of hearing at a later stage, and consequently the condenser will have to be operated continually. If the interference is due only to one station, however, the trap condenser may be adjusted to eliminate this, and the shorting switch only will have to be operated for any other station, thus simplifying operation.

Fig. 7.—A screening box made by Messrs. Stratton which is ideal for containing a receiver to avoid various difficulties.



ITEMS OF INTEREST

Overcoming Instability

INSTABILITY at the bottom end of both the medium and long waveband is nearly always due to the loudspeaker being alive, the trouble, of course, being easily overcome by earthing some part of the chassis to another convenient "earth." Instability through other causes invariably appears at the bottom of either the long or short waveband; seldom both.

Speed of the Cathode-ray Electron Beam

THE speed of the electron beam in a high vacuum cathode-ray tube is extremely difficult to measure with any great accuracy, but it is quite evident that speeds of the order of one-tenth of the speed of light are often attained under quite ordinary working conditions, that is to say, about 18,000 miles per second, or forty-five times around the equator in one minute.

Secondary Emission

MANY modern power valves have a black coating on the inside of the bulb (not to be confused with the "getter"). This is the deposited carbon put there to overcome distortion due to secondary emission. This class of secondary emission is caused by stray electrons, which have missed the anode, impinging on the glass with great speed, causing the glass to give off free electrons which fly to the outside of the anode owing to its high positive potential. These electrons, being absolutely uncon-

trolled by the grid, cause distortion. Owing to the high velocity at which the original stray electrons hit the glass, they drive off electrons out of all proportion to their number.

Modern Valve Electrodes

THE average user of a wireless set has little idea of the indignities to which valve parts are subjected before they take their place as part of the complete structure. To recount them all would take many pages, but there is one worthy of separate mention. Almost all the electrodes in a valve, even the most delicate grids, are put into a hydrogen oven and raised to the really cheerful temperature of 1,600 degrees Fahrenheit (rather more than cherry red) and are held at this temperature for anything between fifteen and thirty minutes.

The idea of the hydrogen is to keep the surface of the metal parts free from air, the oxygen in which would bring about a dull surface, whereas by being heated and cooled in hydrogen, they retain their original bright polish. This baking is done to drive off any gas which might otherwise be liberated after the valve had been in use, and so shorten the useful life of a valve by rendering it soft.

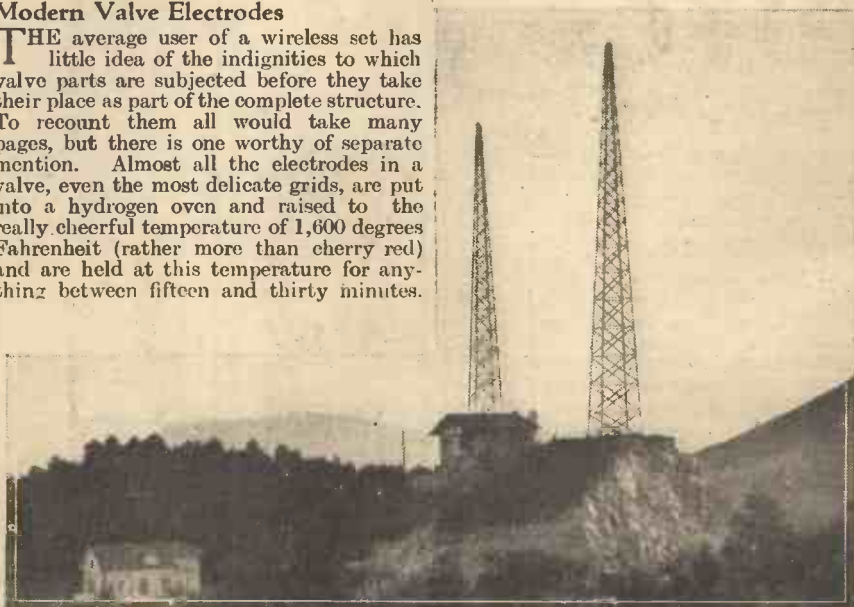

Of particular interest at the present time is this illustration of the radio station at San Sebastian, Spain.

CHOSEN BY

F. J. Camm



The 3-gang condenser specified is the 'K' model (.0005 + .00025 + .00025). It is extremely smooth in operation, and the careful design and rigid construction of every detail assures this fine component of constant service over a long life. Price **15/-**

FOR HIS "RECORD" ALL-WAVE THREE

Two Jackson Bros. components, a three-gang condenser and the Horizontal Drive, have been chosen by Mr. F. J. Camm for his great new set, the "Record All-Wave Three." Mr. Camm knows that for faultless performance and unfailing reliability, components by J.B. are renowned the world over. You, too, must specify J.B. for your set, and you cannot fail to get good results.



The horizontal slow-motion drive illustrated, gives adequate area of scale. Cat. No. 2135. Type SL9. Black or Brown Bakelite Escutcheon; with Air Dielectric trimmer. Price **6/6**



PRECISION INSTRUMENTS

CONDENSERS & DIALS

JACKSON BROTHERS (London) Ltd. 72, St. Thomas St., S.E.1 Telephone: Hop 1837

SHERLOCK HOLMES SAYS..

"Don't guess at the trouble TEST WITH PIFCO RADIOMETER"



12/6

Pifco goes straight to the heart of the trouble, testing sets, valves and components with equal ease and speed. Any radio set can be tested, either A.C. or D.C. Mains or Battery operated. Solidly constructed with fine bakelite case, the Pifco Radiometer has readings for high and low voltage, milliamperes, continuity test, and a special socket for testing valves.

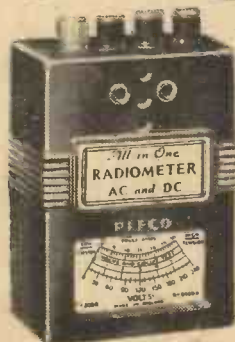

The "ALL-in-ONE" RADIO-METER for A.C. or D.C. For electric or battery radio sets. Finished in black bakelite, size of dial 1 1/2 in. by 3/4 in., complete with leads. Price 12s. 6d.

Get one of these amazing instruments from your local dealer to-day, or write for Testmeter Folder, post free from PIFCO LTD., WATLING STREET, MANCHESTER, or London Office, 150, Charing Cross Road, W.C.2.

PIFCO ROTAMETERS and RADIOMETERS
PIFCO ON THE SPOT WILL TRACE YOUR TROUBLES LIKE A SHOT

CLIX

"OK—
IN EVERY WAY"

Says Mr. F. J. Camm.

"I have now had an opportunity of submitting your baseboard type Short Wave Valveholder to extensive tests.

"I first of all tried it with a short-wave receiver which suffered from microphony. It gave markedly improved results. I next tried it in a short-wave receiver using another well-known make of valveholder and the results were equally good. Finally, I tried it in an ultra short-wave receiver, where, as you know, components need to be meticulously correct in order to avoid noises and variations in inductances caused by the movement of the wires.

"I therefore pass the design as O.K. in every way."

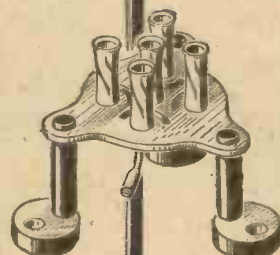

Yours faithfully

Clix Type V.8.
Specified for the
"RECORD
ALL-WAVE 3"

LECTRO LINX LIMITED

79A ROCHESTER ROW. LONDON S.W.1

New Cossor All-wave Receiver

An Efficient Mains-operated Receiver Covering the Short Waves in Addition to the Medium and Long Wavebands:

FOR reception on medium and long wavebands a good straight three pentode receiver will satisfy all but those who must have that little extra selectivity that only a superhet can give.

On the short waves, however, it is a different story, as a straight three valve set becomes virtually a two, because the H.F. amplifier will give only a very small gain (something less than ten times), whereas a high overall gain is very essential on this waveband, and can only be achieved by a superhet.

By a most ingenious circuit arrangement around a specially designed valve, Cossor have solved the problem of a cheap efficient receiver giving a highly satisfactory all round performance on the 17.5/52.5 metre, 200/560 metre, and 826/2,000 metre wavebands.

The special valve, used in the first stage, is a Cossor 41 S.T.H., and cannot be described less simply than as a variable-mu, screened triode-octode frequent changer/H.F. amplifier. Actually this valve is substantially a triode-octode with the second and outer-grid developed as a far more efficient screen than usual, the whole geometry of the valve being such that when the middle grid (oscillator input grid) is grounded, it will function as a variable-mu H.F. amplifier.

This valve, with the aid of suitable but surprisingly simple switching, allows the first stage to function as a normal variable-mu H.F. amplifier on the medium and long wavebands, while on the short wavebands it becomes an equally efficient frequency changer, turning the receiver into a three-valve superhet with adjustable reaction on the intermediate frequency transformer. This arrangement ensures simplicity in tuning and reaction, and when once set can generally be left alone. The reaction control incidentally is geared for easy manipulation.

Detector and Output Stages

The detector stage is a quite conventional arrangement, using an H.F. pentode resistance coupled to the output stage. Tone compensation is introduced by an anode bypass condenser. Further tone compensation is effected by a resistance-condenser arrangement in the grid circuit of the output valve, which doubtless also assists in keeping out the I.F. frequency.

The output stage makes use of a Cossor P.T.41, directly-heated pentode capable of feeding approximately 1½ watts into the mains energised moving-coil speaker, which has been most carefully designed to offer a purely resistive load at all frequencies. The valve rectifier is quite conventional, and needs no special mention beyond the fact that smoothing is such that no trace of hum was detectable on test at 24in. from the loudspeaker.

The accompanying illustration shows the general appearance of the receiver. The cabinet has a highly polished walnut finish, while the one-piece loudspeaker fret and tuning escutcheon is a metal die-casting sprayed brown to harmonise with the woodwork. The silk covering the speaker opening is neat and unobtrusive, as is also the dial, which is pale coffee colour.

Disregarding the wave-band selector/

on-off switch, there are three controls, and a trimmer. On all wavebands the tuning knob functions in the ordinary way, but on the short waveband it is intended that the trimmer shall be actively used and adjusted on each station received. On the medium waveband, the volume and reaction controls are intended to be used in the ordinary way, but when working on short-waves the reaction control, which, as already mentioned, is of the slow-motion type, should be advanced as far as possible, and the volume control used to regulate volume.

A Creditable Performance

On test, Cossor Model 3783 was first tried out on the long waveband, where it was found possible to receive both Luxembourg and Radio-Paris quite free from Droitwich, while on the medium waveband it was just possible to separate Radio-Normandie from the London National, while sensitivity was such that all worth-while European stations were easily receivable. Tests on the short waveband were carried out over a period of several days and at times appropriate to the various wavebands available. The usual European stations were, of course, received with ease, including Zeesen, Rome, Moscow, and the Vatican. At various times during the first evening eight American stations were heard, including W2XAF, W2XE, W1XAL, and WOF. Two of the identified stations were heard for over a quarter of an hour each, continuity being preserved during the whole time. In the small hours of the morning, it was just possible to tune in to a broadcasting station at Victoria, Australia, which was audible on the loudspeaker, although it was actually

(Continued on page 210)

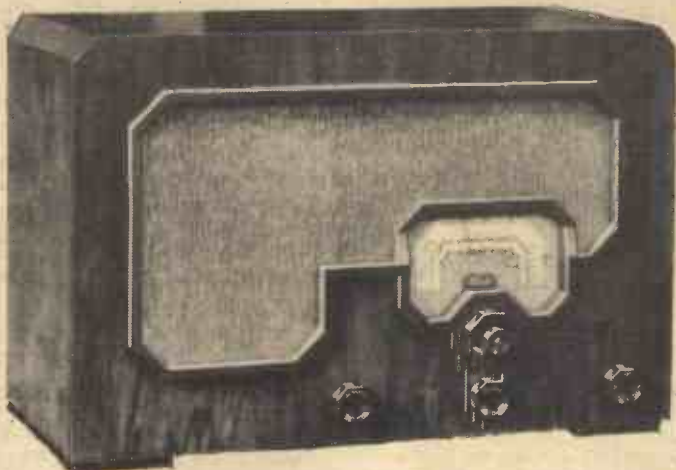

The new Cossor All-wave Receiver (Model 3783) in its attractive cabinet.

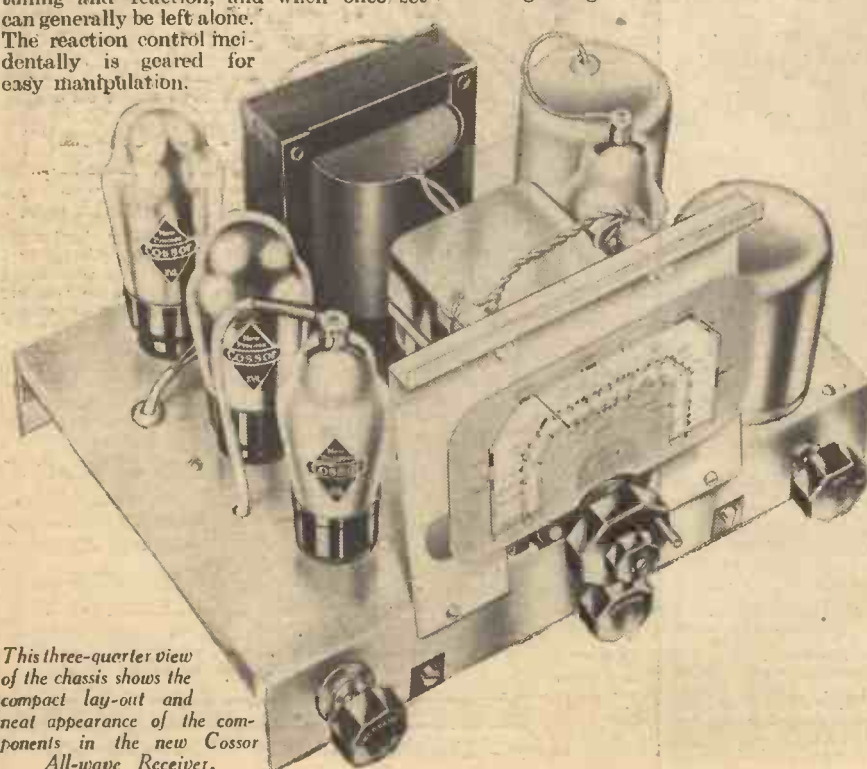

This three-quarter view of the chassis shows the compact lay-out and neat appearance of the components in the new Cossor All-wave Receiver.

NEW COSSOR ALL-WAVE RECEIVER SPECIFICATION

Cossor Model 3783, with 41 S.T.H., special frequency changer M.S.10, H.F. pentode detector, P.T. 41 directly heated output pentode, 442 B.U. rectifier. Short waveband 17.25 to 52.5 metres, medium waveband 200-560 metres, and long waveband 826-2,000 metres, functions as superhet on short waveband, as straight receiver on medium and long wavebands. Special slow-motion tuning, slow-motion reaction condenser, separate volume control.

Mains energised moving-coil speaker. For A.C. mains only, 200/250 volts, 40-100 cycles.

Practical Television

October 31st, 1936. Vol. 3. No. 22.

A Lucky Coin ?

NO doubt many county cricket club captains would like to possess the golden sovereign with which Baird's have "won the toss" for the third time. It enabled the company to start the proceedings for the Radiolympia demonstrations, open the test transmissions at the beginning of October, and finally to transmit the official opening of the B.B.C. Alexandra Palace service of high-definition television on November 2nd. Details of the ceremony have not yet been made public, but the service will be opened by Major G. C. Tryon, the Postmaster-General, while the chairman of the original Television Committee, Lord Selsdon, and Mr. R. C. Norman, chairman of the B.B.C. governors, will take part in the ceremony. Quite naturally this is to be televised, the particular scanner charged with this special work being the intermediate-film equipment.

Old televisioners who have the opportunity to watch this function on television receiving sets will no doubt contrast it with what happened at the first B.B.C. low-definition television broadcast which took place just over seven years ago, namely, on the morning of September 30th, 1929. Sir Ambrose Fleming, the "ever young" inventor of the valve, was the guest of honour on that occasion and in the photograph he is seen with Mr. J. L. Baird in the original spotlight studio. The tiny photo-electric cells, in direct contrast to the large and sensitive ones used to-day, are positioned just above the aperture which enabled the light-spot beam to pass through the wall separating the projector room and the studio. When the photograph was taken the cells were draped to prevent damage from the flashlight. This ceremony was not without its humorous side for, due to an engineer's oversight, the modulating signal was reversed with the result that the features of Sir Ambrose as seen on the television receiver were negative. After two or three minutes the effect was rectified, but with the present high-definition television arrangements there is hardly any likelihood of a similar mistake occurring at the Alexandra Palace. Contrary to expectations there will be two one-hour broadcasts per day (except Sunday) instead of the anticipated three, but no doubt these times, namely, 3 to 4 p.m. and 9 to 10 p.m., will be extended as soon as it is proved that a large section of the public have sets for looking-in at the transmissions.

Programme Critics

Just as in the case of ordinary broadcasting, the success of the B.B.C. television service will be judged by the nature and quality of the sight and sound programmes. To assist in this matter a large number of B.B.C. officials and engineers have had television receivers installed in their own homes. In this way a proper log of what the results are like under home conditions of reception will be made and the collated data will undoubtedly prove of great value to the Alexandra Palace authorities. The work being undertaken is a pioneering

effort and mistakes are sure to be made, but by keeping a careful watch in this way and taking cognisance of the opinions expressed by members of the public who have bought or built the relatively expensive television receivers, it seems certain that Britain's television service will be a model to the world, just the same as the older broadcasting service.

This Range Question

Surprise has already been evinced at the distances over which the ultra-short-wave sound and vision signals have travelled from the Alexandra Palace. Prior to a month or two ago the power of ultra-short-wave radio transmitters had been rather limited, but the present station uses 60 kilowatts input which represents a peak aerial power of 17 kilowatts. The so-called horizon range has been extended easily, and it is conceivable that the ground wave will travel far beyond its estimated distance

owing to the high powers employed. Already there is a talk of increasing the power, but even under present conditions a 50-mile range from the station seems a reasonable estimate. Due to ground configuration or peculiar shielding effects from steel buildings, etc., bad reception spots are sure to be found, but they are likely to be the exception rather than the rule. Under these circumstances, therefore, the original television committee's estimate of ten stations to cover 70 per cent. of Great Britain's population may need drastic revision. The regular signal service now being radiated will enable field strength tests to be undertaken in mobile van units, and it is hoped that the B.B.C. will publish the results at the earliest possible moment.

Big Screen Television

In announcing the various projects for new cinemas up and down the country, it is noticed that in very many cases statements are made to the effect that included in the plans is a provision for the installation of television equipment. This, it is made clear, is for the purpose of providing patrons with an opportunity to see received television programmes on a big screen—the full size cinema screen is stated in some cases. This question of television in the cinemas keeps cropping up, although it seems certain that its progress was held up for a time while

concentrated effort was directed towards the provision of a service of television pictures in the home. Now that this is proceeding along well directed lines, big-screen television is sure to loom once more in the public mind. Support for this was given in the Baird Company's meeting held a few days ago. Both the Chairman and Mr. Baird, who addressed the assembly, mentioned the work now being undertaken by the company in this connection. It has already been stated publicly that in this case three different methods are being tried, namely, direct projection by mechanical apparatus, direct projection with the aid of wholly electrical devices based on cathode-ray tube technique, and also the intermediate-film projection receiver. Actual films obtained by the last-named method were shown about eighteen months ago at a cinema industry conference held at Cardiff, and it is only natural to expect that considerable progress has been made since that time.

Incidentally, at the same company meeting referred to above the price of the "Televisor" receiving set model T.5 was mentioned publicly for the first time. The set is to be retailed at 85 guineas and is capable of giving a received black and white picture of marked brilliance, 12ins. by 9ins.

A Mobile Unit

Two or three weeks ago a description



Modern television systems bring to mind the early attempts and experiments. This illustration shows Sir A. Fleming in the studio with Mr. J. L. Baird in 1929.

was furnished in these pages of the mobile unit used by the German television authorities for televising selected events of the Berlin Olympic Games and also used in the grounds housing the German Radio Exhibition. It is now stated that for the purpose of televising next year's Coronation procession what is virtually a mobile television station is to be constructed for the use of the B.B.C. This is to incorporate an electron camera so that that section of the pageantry which comes within the camera range will be converted into television signals by established electrical methods. For the purpose of relaying these signals to

(Continued overleaf)

(Continued from previous page)

Alexandra Palace two alternatives present themselves. One is to use a co-axial cable link connected to Broadcasting House, which, as readers know, is already joined to Alexandra Palace by a similar cable. Another suggestion is to exploit to the full the advantages of directional microwave links. This latter idea will add considerably to the mobility or flexibility of the scheme, and provided experiment shows that communication can be maintained under the conditions which will operate at that period it is probable that this latter suggestion will be the one employed.

Personality Rights

The Variety Artistes' Federation are keeping a very watchful eye on their members' interests insofar as television performances are concerned. They have warned artistes that if any attempt is made to record their performances for use on any subsequent occasion a special agreement should be entered into. No doubt they have in mind the intermediate-film equipment which makes a perfect film negative of the scene to be televised at the end of half a minute. This film can be dried and used again as often as desired and will no doubt assist in repeat broadcasts.



An interested audience watching a television demonstration in one of the newly-installed H.M.V. television theatres. This will seat forty people.

Television Notes

Puppets and Television

THE British Puppet and Model Theatre Guild staged a most ambitious exhibition a few days ago in Leicester Square. These puppets and marionettes are certainly fascinating creatures and an endeavour is to be made to extend their activities in London. To this end negotiations are in hand for showing the figures by high-definition television. Shows of this nature are admirably suited to this type of performance. Even in the days of thirty-line television the marionettes were a popular feature in the programmes. Owing to the limitations in definition the programme had

to be planned very carefully to give the full effect required when using the spot-light scanner, but in spite of this the results seen on the receiving sets were quite good. With the present degree of definition the pictures should be admirable, and it is hoped that the negotiations will prove successful so that a wider public can be amused by the antics of these string-worked figures.

For Police Purposes

IT is learned that experiments are already being undertaken by Scotland Yard officials for the purpose of applying the principles of television transmission and

reception to the task of aiding crime detection. In one test a "criminal" had his picture televised to a selected spot in London with the result that in much less than an hour he was arrested. For some time photo-electric cells operated by an invisible light beam have acted as protector to safes housing valuables. As soon as the beam is interrupted by an intruder, alarms ring or the room is floodlit, making the apprehension of the burglar a much easier matter. With concealed television cameras it will be possible to televise the actions and conversations of suspected persons from a room to another part of the building, or even radiate them to a police station. This scientific eavesdropper will provide evidence of great value in cases of this character, and we can look forward to the time when every police station will have its own television receiver and mobile units will patrol the streets just as ordinary police cars do now.

Television Sound Wavelengths

READERS who possess a receiver capable of tuning down to the television sound wavelengths may have noticed the extremely excellent quality of this transmission, particularly regarding the great brilliancy of the upper register. This is due to the fact that on this wavelength the side-band width is unrestricted, owing to the absence of adjacent stations, making it possible for the transmitter to radiate harmonics several thousands of cycles above the point where medium and long-wave broadcasting stations have to cut in order to avoid side-band overlapping with their immediate neighbours.

Television versus Home Ciné Apparatus

PESSIMISTS are already suggesting that television is too dear, yet a good home ciné camera and projector outfit costs anything between £100 and £150, and has found a ready sale in spite of its expensive upkeep and relatively limited application when compared with television.

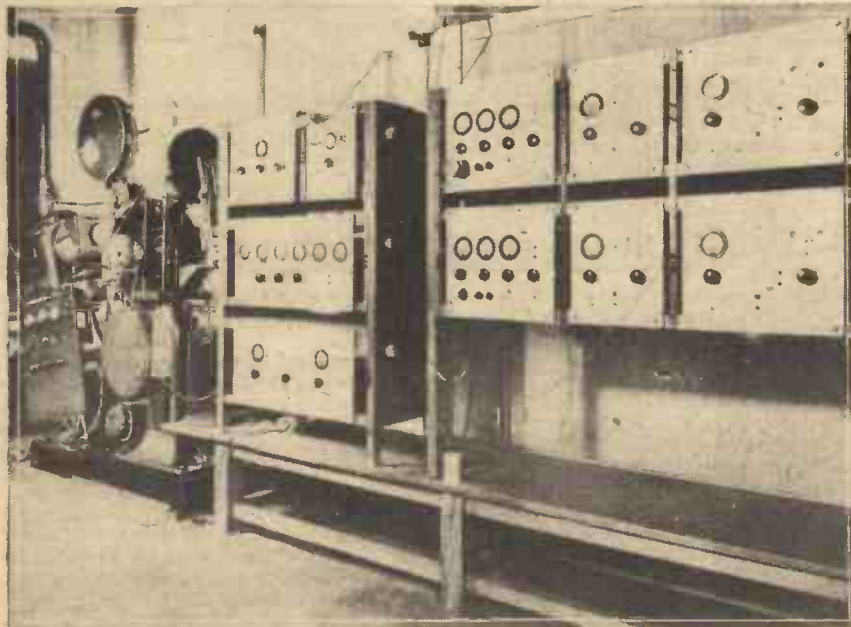

A disc transmitter for films used for experimental transmission of sound and vision at the G.E.C. Research Laboratories; ultra-short-wave panels are on the right, and picture amplification and synchronisation panels are in the centre.

The CYCLIST - - 2d.
Every Wednesday.

A PAGE OF PRACTICAL HINTS

SUBMIT YOUR IDEA

READERS WRINKLES

THE HALF-GUINEA PAGE

A Novel Inspection Lamp

HERE is a very handy bulb-holder with inspection lamp for use in positions where the usual "clip-on" variety is not practicable. For instance, it will stick to the side of a cabinet, under the lid, on condenser

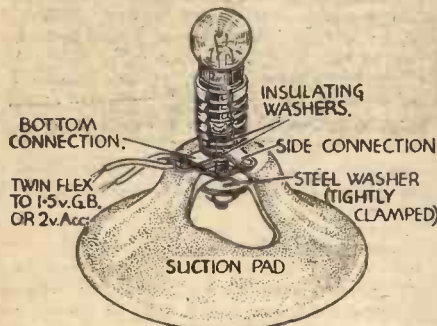

A handy inspection lamp which can be used in any position.

and coil shields, or even on a valve. It is easily made, as follows: Procure an ordinary bulb-holder, of the type illustrated, and a small rubber suction washer about 1in. in diameter. Dismantle the holder, drill a small hole in the top of the suction washer, and assemble the parts as shown. An adequate length of flex should be provided for connecting-up purposes.—E. H. MATTHEWS (Dublin).

Using Pentodes and Extension Speakers without Choke-filter Output

I HAVE found it possible with this idea to effect an alternative to the more usual choke-filter output stage, when employing a pentode and having a number of extension speakers in circuit. As is generally known, an open or intermittently open-plate circuit in the pentode stage will cause the emission of the pentode to depreciate in time, and in utilising this idea

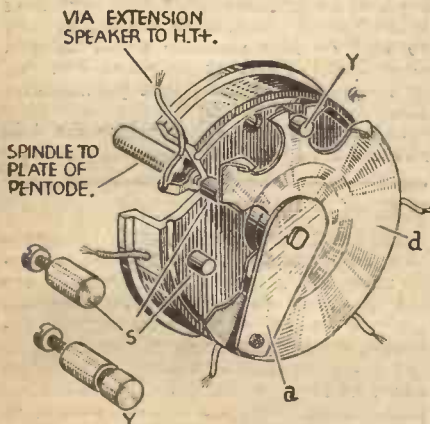

An extension speaker switch for use in conjunction with a pentode output stage.

THAT DODGE OF YOURS!

Every Reader of "PRACTICAL AND AMATEUR WIRELESS" must have originated some little dodge which would interest other readers. Why not pass it on to us? We pay £1-10-0 for the best wrinkle submitted, and for every other item published on this page we will pay half-a-guinea. Turn that idea of yours to account by sending it in to us addressed to the Editor, "PRACTICAL AND AMATEUR WIRELESS," George Newnes, Ltd., 8-11, Southampton Street, Strand, W.C.2. Put your name and address on every item. Please note that every notion sent in must be original. Mark envelopes "Radio Wrinkles." Do NOT enclose Queries with your Wrinkle.

the normal plate-speaker-H.T. circuit can be used, and in switching in and out the various speakers the operation is as follows: The disc (d) is depressed by the arm (a) and contacts with each of the five studs (s) in turn, but before the contact of each stud in turn is broken the next one is made, thus maintaining continuity of load throughout the complete revolution of the rotor arm. The contact studs (s) were made out of 1/8 in. brass rod and taper tapped to take 8 B.A. screws as shown. Owing to the volume control used for this model having the spindle common to the disc, it was necessary to insulate with an ebonite bush when mounting on a chassis.—W. R. HOBBS (Ilford).

S.W. Bandsread Tuning

HAVING experimented considerably with band-spreading methods in my ever-changing short-wave set I have found that although a very small condenser across

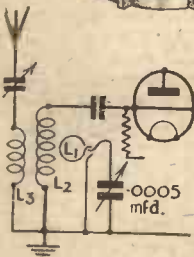
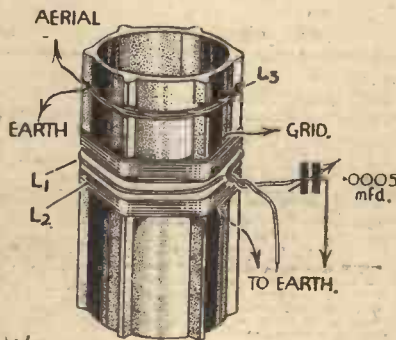

Circuit diagram of a method of S.W. bandsread tuning, and above, a coil for use in the circuit.

the main tuning condenser is effective, hand-capacity results, due to the smallness of the condenser, thus necessitating the use of extension spindles. To facilitate listening on the amateur bands, and also to separate the stations reasonably round the dial, I employ the method of tuning illustrated in

the accompanying diagram. I have eliminated the main tuning condenser altogether and substituted this by a tuning circuit consisting of a .0005mfd. variable condenser (connected to the main tuning dial in place of the original .00016mfd. main tuning condenser) and a single loop, L1, round the grid coil, which in my case consists of fifteen turns on a 1 1/2 in. former. This arrangement just spreads the 40-metre amateur band nicely round the dial, although, of course, you can't get anything else. However, another coil similar to this for the 20-m. band makes "ham" listening both simple and interesting and has the advantage of having two or three degrees between stations instead of two or three stations between degrees.—T. D. MARTIN (Stretford).

A Stop for Bandsread Tank Condensers

TANK condensers for band-spread tuning can easily be fitted with a definite stop by fitting a ball-catch behind the knob, as shown in the accompanying

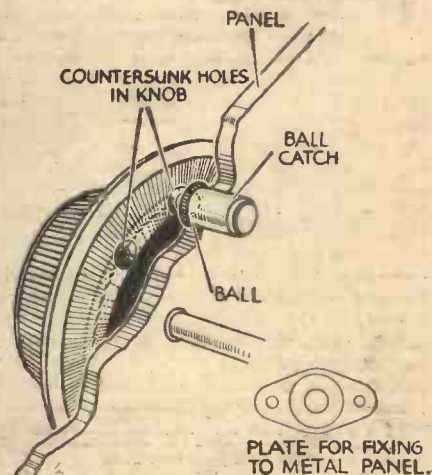

An easily-made and effective stop for a condenser dial.

sketch. The catch can be obtained at any woodwork shop, and when fitted provides a very useful refinement, for besides allowing each position to be felt, the condenser is definitely held at each stop so that stations, once logged, will always come in at the same setting of the vernier condenser. The panel, if of wood or ebonite, may be drilled a push fit for the catch which will then require no further fixing, but for a metal panel a small plate should be soldered to the catch, which can then be secured with two screws. The knob may be marked off by drilling a small pilot hole for the catch and then passing a drill through this to slightly countersink the knob when held at each stop in turn. These holes should then be more deeply countersunk with a drill of about the same diameter as the ball.—J. F. SMITH (Whitley Bay).

Automatic Record Changers

IN our issue dated October 17th last we reviewed some of the more popular types of automatic gramophone-record changer. Owing to a draughtsman's error it is regretted that the makers' names were wrongly given in respect of certain models. The illustrations of the models referred to are reproduced on this page, and it will be seen that Fig. 1 is actually a Collaro product, whilst the Model R.C.4 record changer, shown in Fig. 2, as well as the underside view of another changer, are Garrard products. It is necessary, of course, in reading the text of the article in question to read Garrard in place of Collaro (and vice versa) on pages 127 and 128.

For the benefit of those readers who have not obtained a copy of the issue in question it may be mentioned that the changer shown in Fig. 1, namely, the Collaro model,

into the first record groove even if the record or turntable is not level, and this avoids wear. The bias is applied for only two seconds and thus avoids wear on the sides of subsequent grooves.

A single control carries out the combined operations of starting, repeating, rejecting, and stopping the mechanism. At the conclusion of the last record the mechanism is automatically stopped. The changer is supplied

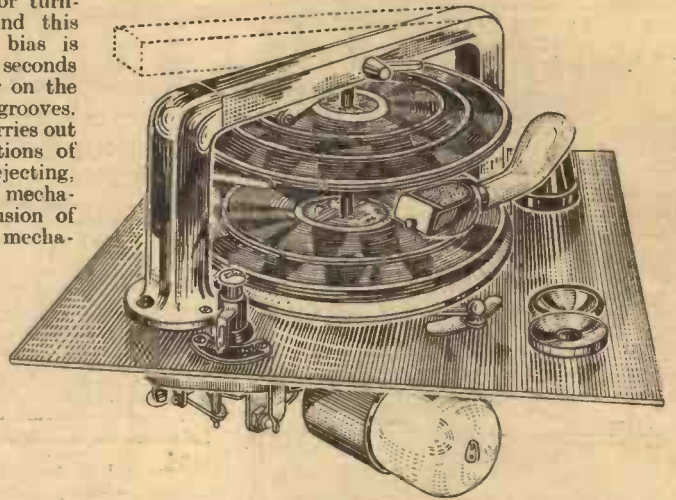

Fig. 1.—The Collaro Ten Guinea Auto Changer which accommodates mixed sizes of records.

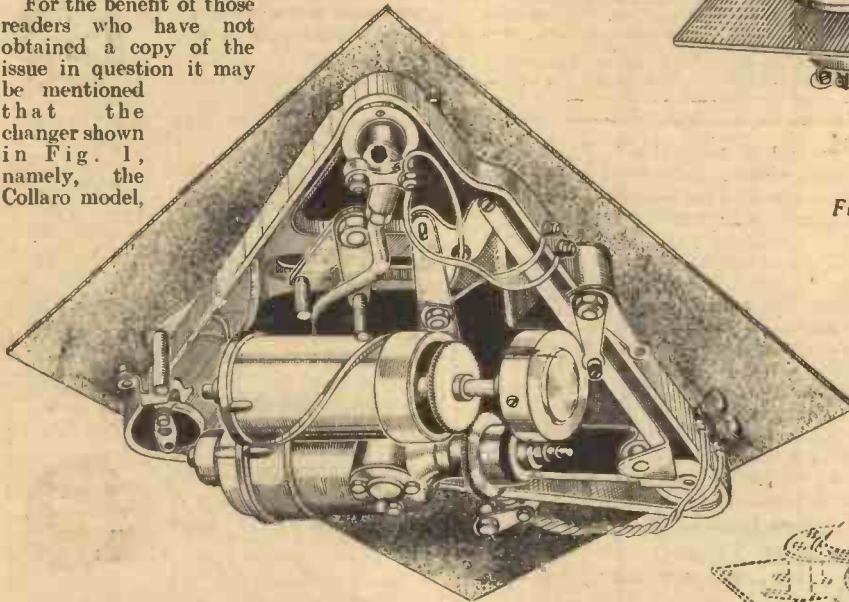

Fig. 3.—An underside view of the Garrard Changer, showing the operating mechanism.

possesses the unique mechanism which permits various sizes of record to be mixed in any order. The mechanism incorporated in this particular changer is mechanically perfect, and changing is carried out smoothly and without noise. The pick-up is biased

with two alternative types of motor, one for A.C. mains only and a Universal model which may be used on either A.C. or D.C. mains. The voltage

adjustments on these models permit of the use of mains having voltages from 100 to 130, or from 200 to 250, and an extremely simple and efficient arrangement is employed to adjust the input for the appropriate mains voltage. The price of the A.C. model is £10 10s., and for the Universal (A.C.-D.C.) model the price is £11 16s. 3d.

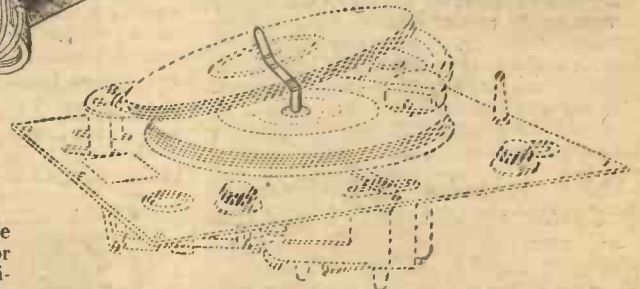

Fig. 2.—This is the Garrard Model R.C. 4, Record Changer, costing £7 10s.

COSSOR ALL-WAVE RECEIVER

(Continued from page 206)

picked up using headphones. As a further Australian station was heard two days later, it must be admitted that this is a truly remarkable performance with a receiver using only three valves.

High Quality Reproduction

The quality of reproduction left nothing to be desired, and indicated very clearly the success that had greeted the efforts of the Cossor engineers to produce a level response for the whole musical scale. Quality of reproduction of certain short-wave stations was particularly excellent, as many of the transmitters worked on a somewhat wider band-width than is possible on the more crowded medium waveband, many, in fact, worked up to 11 or 12,000 cycles, which frequencies Cossor Model 3783 prove it is perfectly capable of handling. The loudspeaker handles the 1½ watts output without any signs of distress, and stations on all three wavebands were received on noticeably quiet backgrounds. As usual with this manufacturer's receivers,



the chassis is an extremely sound workman-like job.

In spite of the very valuable refinement of a superhet working on short waves, and the high performance generally, the receiver is moderately priced at £9 15s. 0d., or may be had on hire purchase terms for 17s. deposit and twelve payments of 16s. 9d., or 17s. deposit and eighteen payments of 12s.

Cossor Model 3783 has valves for A.C. mains only, 200/250 volts, 40-100 cycles.

S.W. Reception Periods

THE later the hour the longer the wavelength, is the simple guide for successful reception on a short-wave band. When the 19-metre band (the twilight band) begins to fade away at the coming of darkness, it is a good tip to move straight up to the 31-metre band ignoring the 25-metre band, as many American stations radiate simultaneously on both sides, and good reception is generally speaking only available for a very short period on the 25-metre band.

PETO-SCOTT EVERYTHING RADIO - CASH C.O.D. or EASY TERMS

Peto-Scott 1937 SUPER SENSITIVE S.G.3 KIT



A NEW VERSION of AN OLD SUCCESS

Without a doubt, the very last word in sensitivity and selective kit, capable of providing real entertainment from numerous British and Foreign stations. Screened grid, detector, Hartley Pentode Output valves.

KIT "A" £47/6
Cash or C.O.D.
Carriage Paid.

Complete set of parts including ready-drilled enamelled steel chassis, less valves, cabinet and speaker.

4/6
DOWN

- SCREENED WAVE WOUND AIR CORE COILS.
- DRILLED GREY ENAMELLED STEEL CHASSIS.
- PICK-UP CONNECTIONS.
- FULL INSTRUCTIONS WITH EVERY KIT.

KIT "B" Exactly as Kit "A", but including set of 3 specified Hircac valves only.
CASH or C.O.D. **£3:10:3**
Carriage Paid
or 5/- down and 11 monthly payments of 6/6.

FULL DETAILS IN BOOKLET "B" (See Coupon)

CONNECT THIS Peto-Scott SHORTWAVE A.C./D.C. PRE-SELECTOR TO YOUR EXISTING SET



and tune-in to America and the whole World on Short Waves. Only a few simple connections necessary and NO ALTERATIONS to your receiver. Incorporates special coil unit covering 15 to 74 metres, and is equipped with an arrangement whereby just a turn of the switch by-passes the Pre-Selector so that your set is then available for reception on normal broadcast wavelengths. SUITABLE FOR ALL RECEIVERS, A.C./D.C. OR BATTERY providing mains supply is available.

9/6
DOWN

- ABSOLUTELY READY FOR USE.
- DUAL RATIO SLOW-MOTION DIAL (8-1,100-1)
- WAVELENGTH-CALIBRATED SCALE.
- B.V.A. VALVES.

COMPLETE UNIT with valves and cabinet illustrated **£4:17:6**
Cash or C.O.D. Carriage Paid.

CUT OUT NOISE!

Peto-Scott NOISE SUPPRESSING ALL-WAVE AERIAL



- Eliminates Man-made Static.
- Increases Signal Strength on all Bands.
- Improves Selectivity.
- Waterproof and Weatherproof.
- Two Transformers.

ASSEMBLED AND READY FOR ERECTION.

The first really economical solution for overcoming the noise of man-made static. The **PETO-SCOTT AERIAL OUTFIT** comprises Duplex enamelled standard aerials, insulators, waterproof "lead-in" wire, Aerial and Set Transformers, assembled and ready with instructions and drawing illustrating method of erection.

CASH OR C.O.D. **£17/6**
CARRIAGE PAID
Or 8 monthly payments of 2/6.

2/6
DOWN

W.B. 1937 SPEAKERS



MODEL 37J, as specified for the Record All Wave 3. Makes an unmistakable improvement in volume and realism of reproduction. Perfectly matches any receiver as principal or extra speaker.

Cash or C.O.D. Carriage Paid, **£1/12/6**
Or 2/6 down and 11 monthly payments of 3/-.
MODEL 37B, Highly efficient Baby Speaker with an adaptation of the famous "Microtone" matching device. Cash or C.O.D. Carriage Paid, **£1/3/6**, or 2/6 down and 10 monthly payments of 2/6.

2/6
DOWN

IMPORTANT Miscellaneous Components, Parts, Kits, Finished Receivers or Accessories for Cash or C.O.D. or on our own system of Easy Payments. Send us a list of your wants. We will quote you by return. C.O.D. orders value over 10/- sent carriage and post charges paid (GREAT BRITAIN ONLY).

RECORD ALL WAVE 3

IMMEDIATE DELIVERY-CASH-C.O.D. or H.P.

AUTHOR KIT "A" CASH or C.O.D. Carriage Paid £4:2:6

Author's kit of first specified parts, as detailed below, including Metaplex baseboard with plywood condenser platform and all necessary connecting wire, screws, etc. LESS valves, cabinet and speaker.

Balance in 11 monthly payments of 7/6

7/6
DOWN

THESE ARE THE PARTS SPECIFIED AND USED BY Mr. F. J. GAMM and INCLUDED in KIT "A"

Any item supplied separately. Orders over 10/- sent C.O.D. and carriage charges paid.

- | | |
|--|---------------|
| 1 B.T.S. All Wave Coil-unit Type 4B.T.U. | £ 5 0 |
| 1 J.B. 3-gang condenser, type K | 15 0 |
| 1 J.B. Slow-motion drive type 2135 | 6 6 |
| 1 Graham Farish .0005 mfd. reaction condenser | 2 0 |
| 3 Bulgin 1/2 watt resistors | 1 6 |
| 1 Bulgin potentiometer with switch, type VM36 | 5 6 |
| 1 Bulgin All Wave H.F. choke, type H.F.15 | 5 0 |
| 1 Varley Niclet L.F. Transformer, ratio 3.5:1 | 7 6 |
| 6 Dubilier specified fixed condensers | 8 6 |
| 2 Peto-Scott Component mounting brackets | 8 8 |
| 3 Clif baseboard mounting short-wave valve-holders | 5 6 |
| 7 Belling Lee Bowspring vanderplugs | 10 4 |
| 2 Belling Lee spades | 4 |
| 1 Peto-Scott Metaplex baseboard, 12in. x 8in. and plywood condenser platform | 1 6 |
| Connecting wire, screws, flex | 1 9 |
| KIT "A," CASH or C.O.D., CARRIAGE PAID | £4 2 6 |
| Set of 3 Specified Valves | £1 6 9 |

Peto-Scott RECORD CABINET

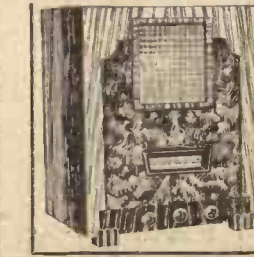

A Modern high grade Console table cabinet, as illustrated, exclusively specified for the "RECORD." Handsome contrasting burr walnut veneer and an attractive fret surround.

Cash or C.O.D., **35/-**
(Carr. and pkg. 2/6 extra) or 8 monthly payments of 5/-. Carriage Paid.

KIT "B" As for Kit "A" but including set of 3 specified valves, less cabinet and speaker. Cash or C.O.D. Carriage Paid, **£5/9/3**, or 12 monthly payments of 10/-.

KIT "C" As for Kit "A" but including valves and specified Peto-Scott Console table cabinet, less speaker. Cash or C.O.D. Carriage Paid **£7/4/3** or 12 monthly payments of 13/3.

KIT "CS" As for Kit "A" but including valves, cabinet and specified speaker. Cash or C.O.D. Carriage Paid, **£8/16/9**, or 12 monthly payments of 16 3.

EASIWAY PARCEL

A useful parcel, containing 2 essential parts to build the RECORD ALL-WAVE 3.

CONTAINS:—
1 B.T.S. All-wave Coil unit.
1 J.B. 3-gang Tuning Condenser
Cash or C.O.D., Carriage Paid **40/-**
or 5/- down and 8 monthly payments of 5/-

5/-
DOWN

RECORD ALL-WAVE 3 FINISHED INSTRUMENT

Ready wired and assembled receiver, comprising all first specified parts, including valves and speaker, and housed in the specified Peto-Scott Console table cabinet illustrated left. Rigidly aerial tested before despatch.

18/-
CASH OR C.O.D. CARRIAGE PAID—**£9/17/6**, or 12 monthly payments of 18/-.

18/-
DOWN

PEACEFUL RECEPTION AT LAST! with a Peto-Scott 3-STATION SUPPRESSOR



No more interference from those powerful local stations, when listening to foreign programmes, if this 3-station suppressor is employed. A new unit constructed to eliminate the local station simultaneously with another medium wave station and also a long-wave station. Equipped with iron-cored coils and air-spaced condensers. Only two simple connections and no alteration to your receiver necessary. Cash or C.O.D. Carriage Paid **£1/2/6**, or 10 monthly payments of 2/6.

Fully described in Booklet "B."

2/6
DOWN

ANY ITEM SUPPLIED SEPARATELY—ORDERS OVER 10/- SENT C.O.D. CARRIAGE AND POST CHARGES PAID

PETO-SCOTT CO., LTD., 77 (Pr. W.7), CITY ROAD, LONDON, E.C.1.
Telephone: Clissold 9875.
West End Showrooms: 62 (Pr. W.7), High Holborn, W.C.1. Holborn 3248.

Please supply..... against Cash/C.O.D./H.P.

I enclose £..... s..... d. Cash/H.P. deposit.

NAME.....

ADDRESS.....

ESTABLISHED 1919.

Buy by Post-its Quicker-

ALL YOU WANT TO KNOW ABOUT A.C. MAINS RADIO, DETECTION & A.V.C.

THE COMPLETE CIRCUIT

Having dealt with each section of the eliminator circuit, an examination of the typical circuits below will show how these sections are inter-connected to form the complete circuit. These circuits may be taken as the basis of any other arrangement, and together with the information given in this book will be sufficient to enable the constructor to build an eliminator suitable for any type of receiver.

GENERAL NOTES ON ELID

It is essential to use a MAINS TRIP switch, a BATTERY is used in the receiver in order to ensure that the "kick" from the supply mains. If a transformer is a possibility of the "live" side of the receiver and receiver.

A Fuse must be used in the line through the receiver and receiver.

apparatus. From short-circuits, "TI" "blow" at six times the normal D voltage-doubler circuit, or three in for the half-wave circuit.

Resistor Condensers of the used, as otherwise the output voltage increased or decreased according to capacities recommended are the cycle supply. If a 25 cycle resistor and filter condenser cycle supply the value, should Smoothing Chokes of coil and, when ordering, it is advised current in order that sufficient choke is carrying this current.

Resistances should be have sufficient current capacity. The Rectifier must be horizontal, i.e., in the ventilation is also necessary for providing ample done by providing ample ventilation. Alternately, this providing an air thus dependent on the result in the receiver design specify any definite for each particular If the instructions carefully, respect to and we respect to or to prepare it in many resistances are same principal pages, etc. up

NOTE—We regret that we are unable to supply circuit diagrams of special eliminators and receiver circuits. From time to time, however, we publish complete instructions for building eliminators designed for use with special receiver circuits published in the technical press. Particulars are advertised in the journals concerned.

"The All-Metal Way, 1937," is more than a catalogue of Westinghouse Metal Rectifiers—it's a text book on A.C. mains radio, distortionless detection and automatic volume control. Every constructor will find it of great use ... and it costs only 3d. post free. Get a copy to-day:



WESTINGHOUSE

METAL RECTIFIERS

COUPON

WESTINGHOUSE BRAKE & SIGNAL CO. LTD.,
82, York Road, King's Cross, London, N.1.

Please send me "THE ALL-METAL WAY, 1937" for which I enclose 3d. in stamps.

NAME

ADDRESS

Pract. W. 31/10/36

Electron breaks another Record!

THE NEW ELECTRON LONG, MEDIUM, SHORT AND ULTRA-SHORT DI-POLE ALL-WAVE AERIAL 5 TO 2,000 METRES

At a popular price

Your set deserves the best aerial you can give it—The ELECTRON All-Wave (Di-Pole) Aerial is designed to give the best results on all waves from 5 to 2,000 metres. Shown at Radiolympia for the first time, and proved an instant success. Experts praised it as being the most efficient form of Aerial ever produced.

Sold in boxes completely assembled and ready for fixing

- EACH BOX CONTAINS—
1. 60ft. Special Aerial.
 - (a) 17ft. } in one continuous length with:
 - (b) 45ft. }
 2. Double-twisted lead-in.
 3. Electron Matching Transformer.
 4. Three special insulators.
 5. Full instructions.



15/-
COMPLETE

CARRIAGE PAID

Obtainable through your Dealer, or direct from

The **NEW LONDON ELECTRON WORKS Ltd**
6, EAST HAM, LONDON, E.6

FARREX OFFER YOU SUPER ALL-WAVE SETS

WHY? FOR AS LOW AS 60/- HOW?

Because your existing Radio Set can be converted to an All-Wave Receiver giving short-wave reception as easily and at equal entertainment value as that of normal broadcasts by just plugging in the new Farrex "All Metal" Converter units specially designed throughout for short-wave work.

STAR

1. ALL-METAL Containers of entirely new design, eliminating Hand Capacity effects.
2. Specially sprung Chassis "floating" inside the Containers, thereby overcoming microphonic noises.
3. Simplicity of operation, giving stabilised reception of the Short Waves, enabling scores of extra Programmes to be received at real entertainment value.
4. One connection only to Model F.1. With A.C./D.C. Power Pack one plug to mains only, one wire to A terminal of set, 79/8 less valves.



Write for free folder

FEATURES

- Aerial of set. No alterations necessary.
5. One Tuning Knob, with special 100-1 Vernier Control.
 6. One Master Switch Control, covering 11.5 to 100 metres, with no coil changing.
 7. Calibrated and Illuminated Dial, with special "clear cut" Shadow Tuning.
 8. Containers available in various colours, toning with any furnishing scheme or Radio Set.
- Model A.F. 9. Identical design and circuit, but no power pack, complete with all adapter plugs, etc., 59/6 less valve.

FARREX RADIO Ltd., Rear of 543, Holloway Rd., N.19. Tel.: Archway 3396.



FILM PRODUCTION

by **ADRIAN BRUNEL**

With an Introduction by Alexander Korda

A complete survey of the intention and methods of modern cinema art for the amateur film-maker, the serious film-goer or the professional. A worthy successor to the author's standard work, "Filmcraft."

7/6 net (8/- post free). This book may be obtained at all good booksellers or at post free rate direct from George Newnes, Limited, 8-11, Southampton St., Strand, London, W.C.2.

NEWNES : LONDON



SHORT WAVE SECTION

SCREENING AERIAL DOWNLEADS ON SHORT WAVES

Various Aerial Schemes for Eliminating Static are Discussed in this Article
By GIEVE SOLLY

UNTIL recently it had been well established that screened aerial downleads would only exclude electrical interferences on medium- and long-wave broadcast wavelengths. Whereas those of small diameter and high capacity necessitate impedance matching to cover wavelengths between about 200 and 2,000 metres, the type having a large diameter and low capacity can be employed on wavelengths as low as 75 metres, merely by careful choice of a low tapping on the aerial coil in the set.

Below 75 metres the self-capacity of even the low-capacity screened lead, bearing in mind that lengths of 20ft. to 50ft. are usually employed, begins to assume a capacity-reactance which is only of a few ohms. At wavelengths bordering on 16 metres there is virtually a short-circuit to earth of the minute high-frequency signal currents, and hence the losses are such that the signal pick-up from the aerial is non-existent at the aerial terminal of the receiver.

Due to the heavy signal losses encountered on short waves, it has been the universally acknowledged practice amongst designers and manufacturers to dispense with screened downleads for all-wave aerial kits. The main purpose of those aerial systems evolved has been directed to efficient and noise-proof short-wave reception, and although the writer may be taken seriously to task, it must be stated that generally little regard has been taken to provide for similar noise-free results on medium and long waves.

Now in fairness to all concerned, it should be made quite clear that it is an extremely difficult matter technically to design an all-wave aerial which, while completely excluding electrical static on the downlead on medium and long waves, does so to an equal extent, or alternatively without serious losses, on short wavelengths. The position is best explained by merely considering simple unadorned aerial schemes.

Reducing Length of Aerial

Whereas a simple T or inverted L aerial will provide a high measure of signal current on broadcast wavelengths (including long waves), its efficiency rapidly deteriorates the lower the wavelength the set is tuned below 200 metres. By reducing the length of the horizontal span so that it approximates in length to the actual fundamental or half or quarter of the actual transmitted frequency (wavelength), much better results are achieved on short waves. Note the singular "frequency"; the length of a short-wave aerial span can only be adjusted to one particular wavelength. The problem is obviated by using two

horizontal spans of dissimilar lengths, each of which is adjusted to cover a band of wavelengths each side of its natural resonance point. Connection to the receiver is made by means of a twin cable, which, according to present day practice, can either be twisted or arranged as a cross-over type with insulators spaced at regular intervals. Both kinds of twin downleads are unscreened, it being a condition of the

short wavelengths somewhat removed from the resonance point.

Twin feeder downlead aerial systems undoubtedly provide a large measure of relief from electrical static on short waves, but, due to these interferences being of a different character on higher wavelengths, the noise-reducing properties described become increasingly less effective towards the medium waveband. One solution which the writer has consistently advocated for overcoming the difficulty of electrical static elimination is to employ two separate and distinct aeriels, the first to be used for reception between 13 and 75 metres and the other between 75 and 2,000 metres.

Each aerial would be arranged in the most desirable manner for reception at the particular frequency ranges desired and, of course, without the necessity for compromise in design. It is a regrettable fact that very few listeners view the proposed scheme with favour, as objection is often raised to the use of even a single outdoor aerial, which is essential if carrier wave radiations are to be received clear of local zones of interference.

All-wave Aeriels

Much thought has recently been given by designers to the problem, that is, to arrange an all-wave aerial with a screened downlead which at the same time will not too seriously attenuate short-wave transmissions. The first commercial model of this type is the "Eliminoise" (Fig. 1) described in Bulletins Nos. 26 and 27, and produced by Belling and Lee. This consists of a twin screened twisted downlead of the standard "Rejectostat" type, coupled to triple-range step-down aerial and step-up receiver transformers, the former having a ratio of 6 to 1 to match the 110 ohm twin
(Continued overleaf)

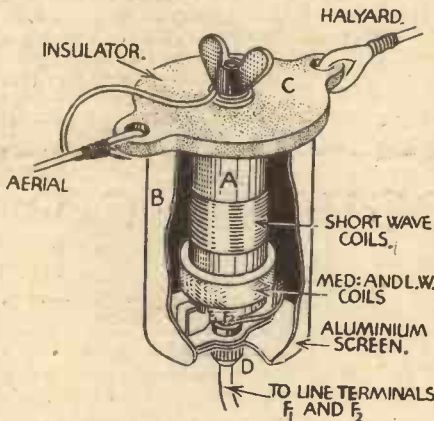

Fig. 1.—A diagram showing the method of construction of the Belling-Lee Aerial Transformer, as supplied in the Eliminoise Aerial system.

coupling unit at the receiving end that it should cancel out and earth interfering currents due to electrical static induced equally into both leads. Owing to the true signal currents being of an oscillating nature, they are passed on to the receiver via suitably coupled windings. To avoid attenuation, the windings in question must be tightly coupled, but the transference of interfering currents due to the resulting mutual capacity can be avoided by astatically connecting the coils. In any event, some loss of efficiency is bound to occur, but it will be found that it is of small magnitude compared to that on medium and long waves, due to the cutting down of the aerial spans.

The use of dissimilar horizontal aerial spans theoretically does not provide an equal signal oscillatory current in the twin downlead, and hence some makers arrange their kits with aerial spans of similar length to achieve this object. Furthermore, the lengths of wire chosen are at the best a compromise with regard to the natural aerial wavelength and complete all-wave coverage. It is, perhaps, fortunate that most all-wave receivers have a considerable reserve of amplification, which, together with the usual A.V.C. action, completely masks losses due to the aerial and at

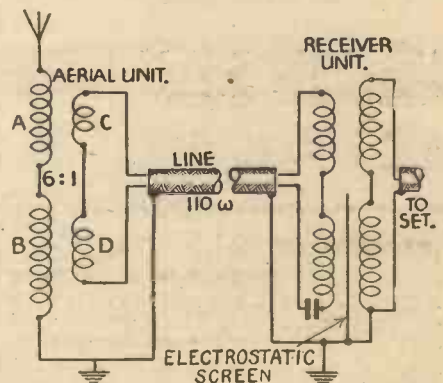

Fig. 2.—This diagram shows the theoretical arrangement of the complete Eliminoise Aerial system. Note the electrostatic screen between the medium-wave windings.

SHORT WAVE SECTION

(Continued from previous page)

screened transmission line. Although insertion losses occur, these are carefully apportioned to fall at the least used wavebands. In terms of noise-free signals, where the volume control may be advanced without the introduction of static, it may be said that the actual result is a gain in aerial input at the set. Readers who desire further detailed information are advised to refer to the bulletins.

An opening statement to the effect that even a single conductor low-loss screened downlead reduces short-wave signals to a negligible value at the receiver input is only true when the screening acts as an earthed casing for the central downlead conductor. Every twin and single screened downlead has a surge impedance which can vary between wide limits, although usually between 70 to 120 ohms and depending on the physical construction. By matching the aerial impedance to that of the downlead—whatever the screened type—the latter no longer acts merely as a capacity, but as a transmission line or feeder. A twin *unscreened* downlead acts in a similar manner except for one important difference. Whereas it can be affected by intense static radiation, particularly if created within a few feet of it, the screened equivalent, with the outer metal sheathing earthed, completely guards the "live" central conductors even when *touching* an offending electrical appliance.

Single Screened Leads

For general all-wave reception there is reason to assume that the usual small diameter twin screened feeder offers better possibilities of consistent results than equivalent single screened conductors. Low-loss single screened leads, or coaxial cables, of large diameter (such as "Metocel"), on the other hand, are more suited for *fixed* ultra short-wavelengths such as used for television. By careful matching, the aerial and downlead can be made very efficient at the fixed wavelength for which they are designed. It is a question of coupling a 7-metre aerial, which can be a single half-wave vertical or a twin quarter-wave horizontal dipole, each of approx. 5,000 ohms, to a coaxial feeder of "Metocel" which has a surge impedance of about 96 ohms. In the former case the vertical aerial, being half-wave, would necessitate a physical length of 3.5 metres or 11ft. 6ins. Matching is effected by parallel wires approx. 4ins. apart and each 5ft. 9ins. long (1.75 metres). One wire is an extension of the central coaxial conductor and terminates vertically as a dead-end. The *equivalent* parallel wire is a bottom extension of the vertical aerial, and connects to the screening of the downlead.

To erect this aerial clear of interference zones it should be hung from, say, a 20 to 25ft. mast mounted on the roof, and at a point as far removed from the roadway as can be arranged. The reason for this

precaution is that ignition static due to motor-cars is vertically polarized and can impinge on the vertical collector. An even better plan is to erect the aerial on a high mast at the back end of the garden and run the coaxial feeder to the receiver along the fence on insulators.

Horizontal Dipole

For a 7-metre quarter-wave horizontal dipole each span will be 5ft. 9ins. long. The impedance at the centre will be approximately correct for the "Metocel" feeder, the inner conductor and external metal sheathing of which will connect direct to the inner aerial ends respectively. In both cases the outer metal screening of the cable can be earthed, a condition satisfying electrical static exclusion.

A low-loss coaxial cable can be fitted with a pair of twisted insulated conductors to provide a variety of aerial arrangements and not necessarily for fixed wavelength reception. The provision of an all-wave noise-proof aerial system with screened downlead to extend down to 7 metres can hardly be considered a practical proposition, that is, if severe attenuation is to be avoided.

It has been clearly demonstrated that high efficiency on short waves down to about 13 metres is wrapped up with aerials, which must bear a physical relationship to the actual frequency to be received, and that any departure from this practice results in losses.

ON several occasions mention has been made in these columns of broadcasts from Spain on short waves by both parties at present engaged in the civil war. Not only are small stations in the amateur band used for the purpose of transmitting news bulletins but also some of the 200-watt stations of which so large a number had been installed during the past two years. Of these stations, although of low power, the following can be heard in the later evening hours: Alcalá de Henares (198.5 m.), Jerez de la Frontera, Jaén and Ciudad Real (199.3 m.); also Albacete, Santiago and Alcoy, which at times may be disentangled from the Belgian private broadcasters working on the 201-metre channel. The principal short-wave stations used by the Government Party (*Frente Popular*) in addition to EAQ, on 30.43 m. (9,860 kc/s) are the Pozuelo del Rey (Madrid) transmitters: EHY, 14.38 m. (20,860 kc/s); EDN-EDS, 28.25 m. (10,620 kc/s); EDS-EHY, 29.79 m. (10,070 kc/s). These stations assure communications in both wireless telegraphy and telephony.

Calls in Five Languages

On 16.878 m. (17,780 kc/s), if you care to tune in at G.M.T. 14.00, you should pick up a call from W3XAL, Boundbrook (N.J.), relaying the WJZ, New York, National Broadcasting Company's programmes. Unless you hear the first announcement you may take the station for a Continental one as the call is given out in five different languages. Should you miss it at the start of the broadcast try at any time until G.M.T. 22.00, when the studio signs off. As a rule, the U.S.A. transmitters put out their call every 15 or 30 minutes, and punctuality is so accurate that you may set your watch by them. W3XAL is a 35-kilowatt and its signals possess a punch.

Leaves from a Short-wave Log

An Unexpected Find

Right in the middle of a group of commercial telephony stations the call *La Voz de los Andes* was logged a few nights ago. It emanated from HCJB, Quito (Ecuador). To make it perfectly clear the announcer spelt it out: *H as in Harry, C as Chicago, J as Jones and B as in broadcast.* (Jones, in parenthesis, is the name of the owner.) The wavelength was 33.52 m. (8,950 kc/s). Interval signal consisted of notes on four different-toned gongs. Broadcasts are made irregularly, but as a rule on Tuesdays and Saturdays between G.M.T. 00.00-00.30.

And now Sweden

SM5SX, Stockholm, on 25.63 m. (11,705 kc/s), appears to have adopted a regular daily schedule. The programmes of the Swedish capital are relayed from G.M.T. 06.45-07.45; 11.25-12.00; and 16.00-22.00, with the exception of Saturdays and Sundays when, during the afternoon, the station works from 12.00-22.00 and from 14.00-22.00 on these respective days. The signals are very good, and the quality all one can desire; the broadcast is certainly of programme value. Stockholm and Motala, owing to their proximity in frequency to Rome on the one hand, and to Warsaw and Reykjavik on the other, are not always easy to receive without interference; it will be found that on most days the SM5SX channel is a more favourable one.

On Wednesdays the station broadcasts a special concert to North and South America between G.M.T. 22.00-23.00.

News from the Dominican Republic

HIX (Ciudad Trujillo), Trujillo City, which hitherto has been working on 50.17m. (5,980 kc/s) may now be found on a higher frequency, 6,130 kc/s (48.92 m.). The power has also been increased, but the schedule remains constant: G.M.T. 12.40-15.40 (Sunday); 17.10-18.10 and 21.40-22.40 (Tuesday and Friday), and 01.10-03.10 (Wednesday and Saturday). On other days a continuous programme from 21.40-22.40 only. Contrary to custom, HIX does not use a slogan, but the simplified call: *Radiodifusora HIX* (heard as *achey-ee-eckis*). A recent search for this transmission resulted in a reception slightly heterodyned by COCD, Havana (Cuba), which would appear to have now moved farther away from the intruder. HIN, also in Trujillo City, which had been recently reported as transmitting on 47.89m. (6,265 kc/s), has now appeared in a much higher portion of the frequency band; it has been heard testing on 11,280 kc/s (26.6 m.) with announced wavelength. So far I have not yet been able to secure its correct address, but Radiodifusora HIN, Ciudad Trujillo, Dominican Republic, should be sufficient. It styles itself *The Voice of the Dominican Republican Party* and lets you know this fact every 15 minutes.

New York Stock Exchange Quotations

If any readers are interested in the U.S.A. exchanges they may care to get the prices direct from New York; they are broadcast by W2XAD, Schenectady, on 19.56 m. (15,330 kc/s) daily at G.M.T. 20.45. This station is on the air from G.M.T. 15.00, and usually closes down at 21.00, when W2XAF takes over until 05.00.

THE BRITISH LONG DISTANCE LISTENERS' CLUB

W8XK—Letter of Thanks

SIR,—Re the scheme which you very kindly put in PRACTICAL AND AMATEUR WIRELESS.

I have just received the following "Official Letter of Thanks" from W8XK.—E. A. J. BARRS (Andover).

"We wish to express to you our sincere appreciation for your letter advising how the programmes of the 19-metre transmitter of W8XK were received. We are always glad to get such reports as these as they are helpful and let us know that our short-wave stations are affording you a programme service which you enjoy.

"Also, please express our appreciation to the following listeners whom we understand assisted you in compiling the information:—

- "Mr. G. Collett, Lincoln.
- "Mr. V. Thomas, Londonderry.
- "Mr. C. G. Jones, Portsmouth.
- "Mr. G. R. Lewis, Cheltenham.
- "Cadet F. A. Moyle, Pangbourne.
- "Mr. D. Jones, London, S.W.14.
- "Mr. G. W. Horton, Rotherham.
- "Mr. J. G. Taylor, Cardiff.
- "Mr. E. P. Trewinnard, Surrey.
- "Mr. H. Willetts, Bolton.
- "Mr. L. J. Marsh, Portsmouth.
- "Yours very truly,
"J. E. BAUDINO,
"Plant Manager, KDKA."

COCX's Address

SIR,—Since my letter to you re COCX I have received a "veri" from this station. It contains no data as to the wavelength or frequency, but gives the address: "COCX La Voz del Radio Philco," Apartado (P.O. Box) 32, Habana, Cuba. Hoping this will be of interest to other readers.—J. LILLYWHITE (Shoreham).

Identification Required

SIR,—Could any of the "B.L.D.L.C." members help me out in a problem which has just cropped up regarding the identity of a certain station? Here are its particulars:—

Frequency: about 6,780 cycles.
Date: 6-10-'36.

Time of transmissions: doubtful, but I tuned in at 14.00 G.M.T. and it closed down at 14.35.

Male announcer. Language: Well, it sounds Eastern, if you understand me.

Type of programme: completely composed of guitar music—tangos, etc.

Power here at R8-9, slight fading, so it's either fully powered or else near by; it's the first time I've come across it and cannot identify its origin, so possibly other members can help me identify it.

Also, I'd like to thank Mr. W. Beard for his information (PRACTICAL AND AMATEUR WIRELESS for September 19th) regarding Radio-Podebrady; I've been trying to sort this one out. Here's a bit more information regarding the transmissions on 19.698 metres: I can receive it daily and it usually comes on the air round about 13.30 G.M.T. and closes down at 18.00; announcing in English at times.

Has Hong Kong opened up an experimental transmission on about 31.5 metres? I logged one last week calling itself Hong Kong but giving no call-sign; unfortunately, Morse interfered at times and so spoilt my only chance of getting its exact

wavelength—that's the snag of not having a wave-meter; still, we are managing pretty well without one. I have not got as much room as I'd really like to play about in and one has to have one's kit at a minimum in case of moving at short notice. Still, maybe someone else has also picked up that transmission and can help me out.

Here are its particulars:—
Sunday, 4-10-'36, at 13.45 G.M.T.
English announcements. Male announcer.
Used Big Ben as a time signal at 14.00 G.M.T.

Close down at 15.30.

Frequency: round about 9,700 cycles.
—AUSTIN S. READ (Aden, S. Arabia).
[Can any member assist Mr. Read to identify the stations?—Ed.]

LITZ-WOUND COILS

IT is not generally appreciated that the old coils wound with Litz wire on formers up to 4in. diameter are actually more efficient than the small modern air-cored coil. The reason for this apparent retrograde tendency is that the small coil is necessary in order that it may be efficient when housed in a metal can. The old 4in. Litz coil would require a screening can about 12in. diameter to be as efficient as the modern 1in. coil in a 3in. can. The aim of a modern coil designer is to produce the most efficient coil possible in a can of practical dimensions. Litz-wound miniature iron-cored coils are often, however, far more efficient than the old 4in. Litz coil, irrespective of whether they are canned or not.

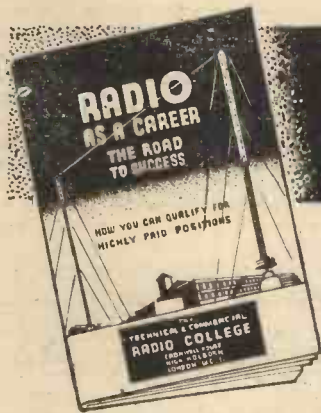

BIG PAY FOR TRAINED MEN

Are you wasting precious hours when you should be preparing for well-paid employment and an assured future? We can train you for a successful radio career and introduce you to employers, or teach you how to earn money in your spare time and become your own master.

Read these extracts from a few recent letters from students:—

"I have obtained fresh employment at a much higher salary through giving particulars of your Course which I am taking."

"He engaged me at a big increase in salary. I couldn't have got the situation without your help."

"I have much pleasure in announcing an increase in salary and promotion."

"I could not have obtained this job without your Course."

"I was engaged on the spot as Engineer-in-Charge of their Service Department."

"My engagement was due entirely to the technical knowledge I gained from your training."

"I have been delighted with the whole Course and am already earning more money because of it."

"I have obtained a position at double the pay."

FREE What they have done, you can do. Take the first step to success and better pay by sending at once for your free copy of "Radio as a Career." Post coupon below.

Radio offers golden opportunities to the TRAINED MAN, and we can give you the training which leads to success.

Without interfering with your ordinary occupation you can learn in your own home how to become a well-paid radio engineer. Our home Study Courses are praised by leading radio authorities. We specialise in Radio and our Courses are conducted by practical radio experts.

This College is licensed by the L.C.C. as an Employment Agency and every student is given personal advice and help in obtaining spare-time or full-time employment.

TECHNICAL & COMMERCIAL RADIO COLLEGE

We have moved to larger premises; please note new address:—

**FAIRFAX HOUSE,
HIGH HOLBORN, W.C.1.**
(Phone: Holborn 7450.)

Our continuous growth is due to the successes of our many students.

Post in unsealed envelope: 1d. stamp.

To: T. & C. RADIO COLLEGE,
Fairfax House, High Holborn, London, W.C.1
Please send me free copy of "Radio as a Career," in plain envelope, and tell me how I can get well-paid employment or profitable spare-time work.

NAME
ADDRESS
PR75

Let Us Send You This 40-Page Booklet—Free



It gives full information regarding various I.C.S. Courses of Instruction in Radio work.

The Radio industry is progressing with amazing rapidity. Only by knowing thoroughly the basic principles can pace be kept with it. I.C.S. Instruction includes American broadcasting as well as British wireless practice. It is a modern education, covering every department of the industry.

OUR COURSES

Included in the I.C.S. range are Courses dealing with the Installing of radio sets and, in particular, with their Servicing, which to-day intimately concerns every wireless dealer and his employees. The Equipment Course gives sound instruction in radio principles and practice.

There is also a Course for the Wireless Salesman. This, in addition to inculcating the art of salesmanship, provides that knowledge which enables the salesman to hold his own with the most technical of his customers.

Then there are the Preparatory Courses for the City and Guilds and I.W.T. Exams.

We will be pleased to send you details and free advice on any or all of these subjects. Just fill in, and post the coupon, or write in any other way.

International Correspondence Schools, Ltd.,
Dept. 94, International Buildings,
Kingsway, London, W.C.2.

Without cost, or obligation, please send me your "Radio" booklet of information about the Courses I have marked X

- COMPLETE RADIO
- RADIO SERVICING
- RADIO EQUIPMENT
- RADIO SERVICING AND SALESMANSHIP
- WIRELESS ENGINEERING
- EXAMINATION (state which)

Name Age

Address

RANDOM JOTTINGS

David Sarnoff's Thirty Years in Radio

RECENTLY Mr. David Sarnoff, President of the Radio Corporation of America, celebrated the thirtieth anniversary of his entry into the radio field.

The Sarnoffs emigrated to America from Uzlian Minsk, Russia, and David, having picked up a little English, started selling newspapers in New York until one day he secured a job as a messenger boy with the old Commercial Cable Company. Thus he began his thirty years' connection with radio communication—as a messenger boy. To-day he is head of America's greatest radio communication company.

He graduated from messenger boy to telegraph operator, and then joined the staff of the Marconi Company. He worked on board ship around Newfoundland in the "sparks" or "CQD" days, and when the *Titanic* sent out her last desperate message, it was young Sarnoff, sitting at his radio receiver on top of a department store in mid-Manhattan, who picked up the message, and who, hour after hour for seventy-two hours, tapped out the names of the survivors.

It was in his early days that he wrote a letter to his chief in which he envisioned a peculiar new musical box which, he said, would be set up in the living rooms of people's homes, and which would pick up music and talk from the air; but his chiefs were too busy thinking of the effect of the World War upon business to take much notice of his letter.

However, his progress was steady and rapid, with the result that before he was thirty years of age, his was an established name in the radio world. Then came the triumph of his career—the establishing of the National Broadcasting Company under the sponsorship and ownership of the parent company which he managed—the Radio Corporation of America. That company grew, and with the coming of talking films, a new subsidiary company was instituted with the name of RCA Photophone, which introduced the latest system of recording and reproducing sound films, and which has played a lead in the technical side of the film industry ever since.

To-day, one of Mr. Sarnoff's main interests is in the field of television. Already many successful experiments have been carried out in America, and during this year a great amount of money is being spent on television development in that country.

IMPRESSIONS ON THE WAX

Piano and Organ

ON the piano Billy Mayerl renders a selection of his own hits from "Over She Goes," London's latest musical success—*Columbia FB 1498*—and, in contrast, presents two syncopated impressions—"Honeysuckle" and "Mignonette"—on *Columbia FB 1485*.

Quentin Maclean will be well in public favour with his interpretations of Ketelbey's "In a Persian Market" and "In a Chinese Temple Garden" on *Columbia FB 1482*.

"Knock, Knock"

AMERICA'S latest nonsense song, "Knock, Knock, Who's There?" is already sweeping this country. The

newspapers have published innumerable "Knock, Knocks," there have been no end of broadcasts, and now it appears on a gramophone record, sung by the Rocky Mountaineers in their own breezy style. "Knock, Knock. Who's there? Emma. Emma who? Emma goin' to have trouble with you?" is typical of the infectious punning absurdities in this song. It is *Columbia FB 1499*.

A Cause of Modulation Hum

A VERY elusive cause of modulation hum is a partial short between chassis and one side of a dial light. A short of this nature will often be of such high resistance that no effect on the brilliancy of the dial light is detectable.

Improving Low-note Response

MOST of the popular methods of improving low-note response seem only to work at the expense of the higher frequencies, giving reproduction a muffled sound, and very often considerably reducing volume. The cheapest and perhaps best method is to use a speaker baffle-board of large dimensions, but where the set is of the all-in type, this obviously cannot be done.

The accompanying sketches illustrate a method of increasing the overall baffle area on a standard all-in receiver, without interference with the receiver itself. This method gives all the benefits of a large baffle.

The two "extension vanes" are of seven-ply wood, stained and polished to match the set. These are the same length as the cabinet; in width they should be at least

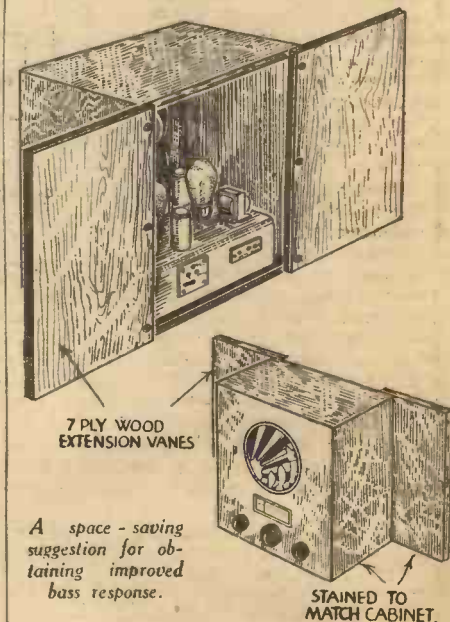

a foot—more if space will allow. When dry they are screwed to the back of the cabinet as shown.

If carefully made and fixed the extra pieces need not spoil the appearance of the set (they are easily removed when necessary), and time spent in making them will be rewarded by greatly improved results.

F. G.

ABC of the Modern Receiver-6

The L.F. Coupling and Decoupling Circuits are Explained, Reference Being Made to Resistance-capacity, Choke-capacity, Transformer and Resistance-fed Transformer Circuits
By FRANK PRESTON

WHEN we come to consider the method of coupling the detector valve to the following low-frequency amplifier—the output valve in the simple circuit arrangement which we are taking as an example—we find that similar principles to those of the H.F. coupling can be applied. In the first place, we may consider the anode circuit of the detector valve as a “load,” as shown in Fig. 1. The main purpose of the “load” is to provide such an impedance, at the frequency of the sound impulses, that the greatest possible voltage is developed between its ends. This is because the voltage between the ends is applied to the grid and cathode of the following valve. Actually, the connection to the cathode is through the H.T. supply, or through a by-pass condenser in certain cases, but that does not affect the point at issue.

A Simple “Load”

As was seen in the case of the H.F. coupling circuit, the simplest type of load is a fixed resistance. (See Fig. 2.) For optimum results, however, this must have a value equal to not less than twice the A.C. resistance of the detector valve. This frequently introduces a difficulty, because the resistance curtails the maximum H.T. voltage which can be applied to the valve when using an H.T. supply (battery, eliminator, etc.) of a given voltage.

This will better be understood by taking a specific example. Suppose that the detector has an A.C. resistance of 12,000 ohms—a fairly average value—the coupling resistance should have a value of approximately 25,000 ohms. Now let us suppose that the H.T. battery has a voltage of 120, that the valve requires 70 volts for optimum working, and that when receiving that voltage it passes an anode current of 2 mA. From

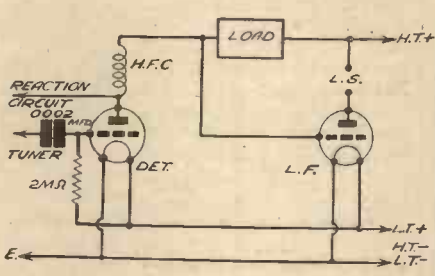

Fig. 1.—This diagram shows the anode “load,” used to couple together the detector and L.F. valves. The circuit is symbolic only, since no means of applying grid bias to the L.F. valve is shown.

of the resistance; this corresponds exactly with the H.F. choke used for high-frequency coupling. The choke has a comparatively low D.C. resistance—500 ohms is a reasonable average value—whilst its A.C. resistance, or its resistance to the audio-frequency impulses, might be almost anything up to a million ohms or so. An important point which must not be overlooked in this respect is that the impedance of a choke is dependent upon the frequency of the oscillations applied to it. And since the audio frequencies in common use vary from, roughly, 50 cycles to 20,000 cycles, we must take some average frequency upon which to base any calculations. A suitable figure for this purpose is 100 cycles, and on this assumption a choke of 40 henries would be required in the conditions set out above. Those who like mathematics will be interested to know that the formula required to determine this is: Impedance (ohms) equals $2\pi fL$, where π is 3.14, f is the frequency in cycles, and L is the inductance in henries.

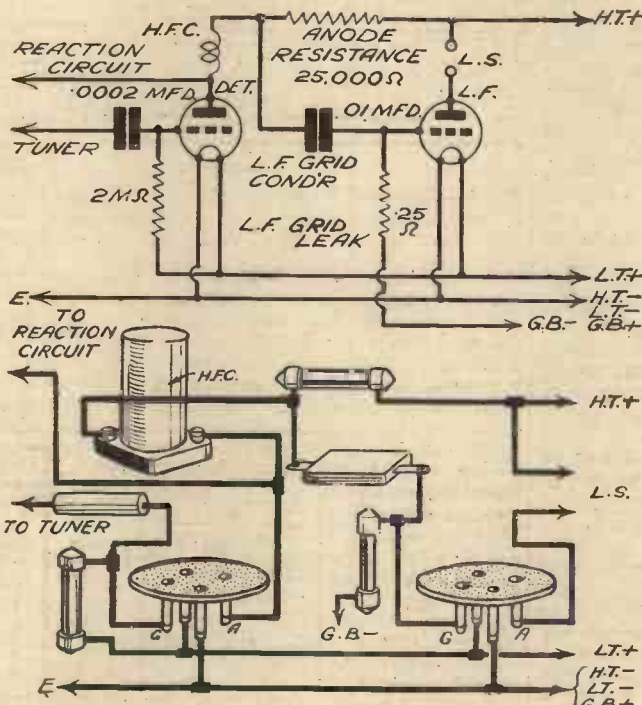

Fig. 2.—Circuit for resistance-capacity coupling. Note the use of grid condenser and leak for the L.F. circuit.

L.F. Grid Condenser and Leak

It can be seen from Figs. 2 and 3 that a grid condenser and a grid leak are required in conjunction with the coupling choke or resistance, and the values of these require to be known. The purpose of the condenser, by the way, is to prevent the positive H.T. potential from being applied to the grid of the L.F. valve, whilst the leak is to carry the grid-bias supply to the valve. The appropriate values can be found by calculation, but the matter is not without complications, and therefore rule-of-thumb methods will be preferred by the average reader. A value of .01 mfd. is suitable for the condenser in nearly any circuit, and it is generally satisfactory to use a grid leak the resistance of which is about eight

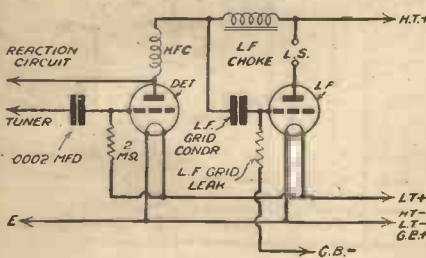

Fig. 3.—Choke-capacity coupling. This circuit should be compared with that in Fig. 2.

the application of Ohm's Law we know that the voltage “dropped” or lost by the resistance is equal to the current (in amp.) multiplied by the resistance in ohms. This gives us $2/1,000$ times 25,000, or 50 volts. It so happens that this is exactly what is required, but the resistance value mentioned would not permit of the use of a decoupling resistance, which will be mentioned later.

It can also be seen that if the valve required a higher voltage or an increased current, or if its A.C. resistance were greater than the arbitrary figure taken, the required result could not be achieved.

Low D.C.-High A.C. Resistance

A very simple way out of the difficulty is to use a low-frequency choke in place

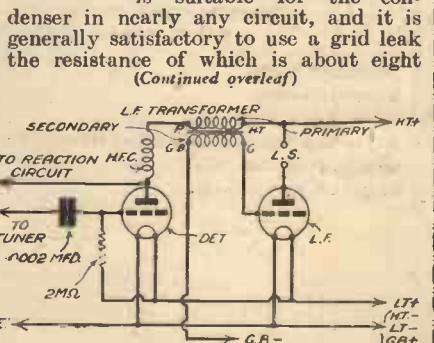

Fig. 4.—Connections for “straight” or ordinary transformer coupling.

(Continued overleaf)

(Continued from previous page)

times that of the coupling resistance, or four times the impedance of the choke. Thus, again reverting to the example given above, a value of 200,000 ohms, or .2 megohm, would be correct. In practice we should take a standard value of .25 megohm, whilst if the coupling resistance had a value of, say, 50,000 ohms, a .5-megohm leak would be chosen.

A factor which is often overlooked is that the coupling condenser must be a good one, with a rated working voltage of at least four times that of the H.T. This is because it has to withstand, not only the H.T. voltage, but also the fluctuating signal voltage applied to it. A mica-dielectric condenser is to be preferred, but a reliable one of the tubular type, and of suitable voltage rating, can be used without very much danger of breakdown; it is, nevertheless, well to err on the side of a voltage rating in excess of the minimum determined from the ratio just mentioned.

Voltage Step-up

The methods of coupling described above are satisfactory in many respects, but are generally employed only when at least two stages of L.F. amplification are to be used. This is because they do not provide any step-up of signal voltage; in other words, the voltage applied to the L.F. valve is only that developed across the "load." In order to obtain a greater L.F. input than this, it is necessary to employ a transformer. As many readers are aware, this consists of a primary and a secondary winding on a soft-iron or iron-alloy core, the secondary consisting of a greater number of turns than the primary. The ratio between the numbers of turns determines the voltage step-up provided; 5,000 turns on the primary and 25,000 turns on the secondary means that the step-up ratio is 1 : 5, for example.

Transformer Ratio

The transformer may be connected as shown in Fig. 4, or as shown in Fig. 5. Referring first to the simpler method shown in Fig. 4, it can be seen that the primary takes the place of the resistance or choke whilst the secondary replaces the condenser and leak. In choosing a transformer for use in a circuit such as this care must be taken that the primary is rated to carry a current not less than the anode current of the detector, and that the inductance of the primary is not less than that required for a choke used in a similar position. This generally means that the transformer must be a fairly massive and expensive one—the "midget" types are not recommended in this circuit unless the detector is operated so that it passes no more than about .5 mA. It is also a good rule to use a transformer having a ratio of not more than 1 : 3.5 when the detector passes more than 2 mA, although the information supplied by the makers should be consulted in this matter.

Resistance Feed

The circuit shown in Fig. 4 ("straight" transformer coupling) can be compared with choke-capacity coupling, whilst that in Fig. 5 is a modification of resistance-capacity, although the transformer takes the place of the grid-leak. This system is known, for obvious reasons, as resistance-fed-transformer coupling. It has

several advantages, which are coupled with the disadvantage that there is, of necessity, a voltage drop across the resistance (which must be of the value used in ordinary R.C. coupling). One advantage is that a small and inexpensive transformer can be used, due to the fact that the primary does not have to carry any direct current; this reduces the nominal impedance to a considerable extent. Another incidental advantage is that the theoretical step-up ratio is obtained, whereas with a "straight" transformer the actual step-up is rather less than the theoretical figure.

It should be mentioned here that there are several transformers now made especially for this type of circuit, whilst there are also several complete coupling units which comprise a resistance and condenser in addition to the transformer.

Purpose of Decoupling

Passing reference was made above to decoupling resistances. A decoupling

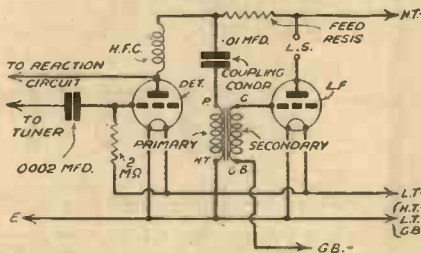

Fig. 5.—Compare this circuit with that in Fig. 4. It shows the connections for resistance-fed-transformer coupling.

resistance is connected in series with the coupling component, or "load," as shown in Fig. 6, whilst a fixed condenser is joined between the junction and earth. Practically, the decoupling components are used to prevent "motor-boating" and various forms of "howls" and distortion which might otherwise be present. These are caused due to the fact that the H.T. supply is in series with the coupling resistance, with the result that a portion of the output voltage from the detector is developed across this unwanted, but unavoidable, resistance. The fluctuating voltage thus produced causes fluctuations in the H.T. voltage supply to the other valves, especially the L.F. valve; this causes a form of low-frequency oscillation.

Resistance Value

The decoupling resistance

prevents the L.F. voltage from reaching the H.T. supply, whilst the condenser provides an immediate and direct earth-return; a direct feed to the cathode circuit of the L.F. valve. A condenser of 2 mfd. is generally to be preferred for this purpose, but a lower value can be used satisfactorily in many cases. The value of the resistance must be calculated by using Ohm's Law given above, so that the valve receives its proper supply of H.T. In calculating the value it is necessary in the first place to find the total resistance required to drop the maximum voltage of the H.T. supply to that required by the detector anode, and then to subtract the resistance of the coupling component. Thus, if the valve required 1 mA. at 70 volts, if the maximum H.T. voltage were 120, and if the coupling resistance had a value of 30,000 ohms, the value of the decoupling resistance could be found as follows: Total resistance required is equal to the voltage drop divided by the current, or 50 divided by 1/1,000, which is 50,000 ohms. By taking 30,000 from this, the decoupling resistance should have a value of 20,000 ohms.

(To be continued.)

TUNED ANODE

WITH modern valves and components, difficulties in connection with H.F. instability are not common, for which reason tuned-anode coupling has become increasingly popular of late.

The reason for including the coupling condenser between the choke and the tuned-grid coil is simply to avoid short-circuit of the high-tension supply. If there were a direct electrical connection here, it is not difficult to see that the H.T.+ lead would be in contact with H.T.—, through the tuning coil. The condenser provides an easy path for H.F. currents, whilst acting as a complete barrier to D.C.

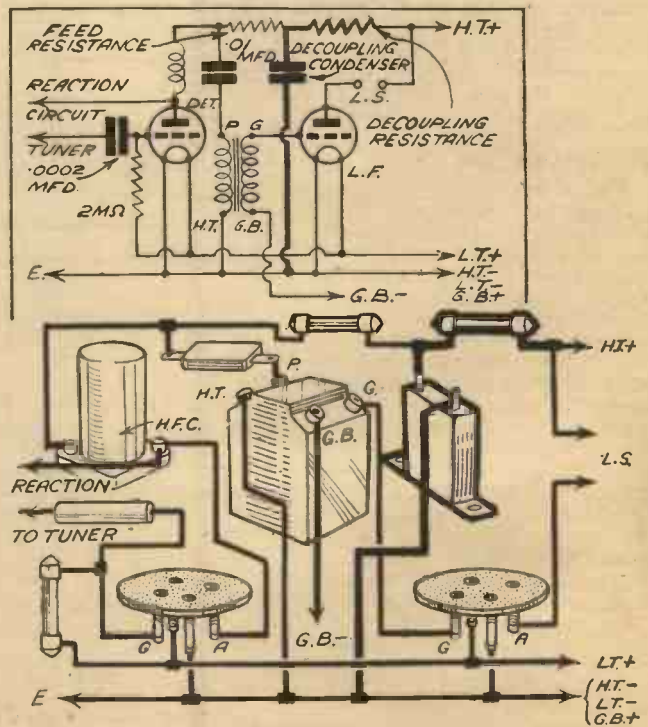

Fig. 6.—This circuit shows how decoupling is added to the circuit shown in Fig. 5. Decoupling components are in heavy lines.

RADIO CLUBS AND SOCIETIES

Club Reports should not exceed 200 words in length and should be received First Post each Monday morning for publication in the following week's issue.

The Croydon Radio Society

OLD hands and new faces greeted Mr. H. R. Rivers-Moore, President, when he opened the Croydon Radio Society's session in St. Peter's Hall, Ledbury Road, S. Croydon, on Tuesday, October 6th. The subject of his lecture was "My Experiences with Microphones and Public Address," and he was soon examining three things; microphones, amplifier, and loudspeakers. In choosing a loudspeaker, its chief criterion for this type of work was its functioning on speech. The amplifier demonstrated had three straight stages resistance coupled, followed by one paraphase stage, and then the two output valves. The topic of microphones proved particularly interesting, and after an examination of various types, the lecturer asked the Society to compare a carbon against a ribbon model. Actually, the latter was pronounced to be more realistic, but the other made speech very intelligible, and was, of course, much cheaper and more efficient.

Mr. Rivers-Moore's public address experience provided him with plenty of scope and reminiscences, and it was realised that it was not always easy to fill a large hall with the human voice.

Hon. Publicity Secretary, E. L. Cumbers, Maycourt, Campden Road, S. Croydon.

Oxford Short-wave Radio Club

AT the September meeting of this Club the programme for the coming winter season was discussed, and it was decided to arrange a series of talks and discussions by members on Radio Technology. The first talk in the series was given on Tuesday, October 27th, when Mr. P. G. Tandy spoke on the Fundamental Principles of Component Performance. Further particulars of the Society's activities can be obtained from the Hon. Sec., Mr. E. G. Arthurs, 13, Walton Well Road, Oxford.

The Ipswich and District Amateur Radio Society

READERS living in Ipswich and District may be interested to know that "The Ipswich and District Amateur Radio Society" meets twice a month, the second and fourth Tuesday at 8 o'clock, during the winter season.

Morse classes have been started, and interested readers should write for further particulars to: The Honorary Secretary, Ipswich and District Amateur Radio Society, D. H. Barbrook, G8AN, Radio House, St. Peter's Street, Ipswich, Suffolk.

Bradford Short-wave Club

THE above Club commences its winter programme on Friday (October 30th), when Messrs. Lissen, Ltd., are coming along to give us a demonstration of short-wave sets and equipment.

The demonstration will be held in the Club room at Bradford Moor Council School, Leeds Road, and commences at 8.30 p.m. All BLDLC and BSWL members will be cordially welcomed.

Particulars of further items in the winter programme may be obtained from the Secretary, Mr. G. Walker, 33, Napier Road, Thornbury, Bradford.

The Cardiff and District Short-wave Club

THIS Club has recently been very active, and visits have been paid to the Telephone Exchange of The Cardiff General Post Office, the B.B.C. Studios at Cardiff, the West Regional Station at Washford Cross, and the Upper Boat Power Station.

Meetings are now being held weekly at the clubrooms in City Road, Cardiff, and lectures and demonstrations are given at each meeting. Messrs. Lissen, Ltd., recently gave a demonstration and lecture on their latest range of receivers, and this was eagerly followed by a large attendance of members.

It is expected that the Club will possess an Artificial Aerial Transmitting Licence in the very near future, and Morse practices are again very popular. The Hon. Sec., Mr. H. H. Phillips, of 132, Clare Road,

Cardiff, will be pleased to give any information regarding the club's activities. PRACTICAL AND AMATEUR WIRELESS readers are invited to attend these meetings.

West London Radio Society

ON Wednesday, October 7th, the above Society held their first meeting of the winter season. Our president, Mr. Douglas Walters, gave a very interesting demonstration of a 16-valve Hammurand Super Pro. Many new members have joined the Society, all of whom enjoyed their first meeting.

These meetings will be held every Wednesday at the "Anchor," 94, Uxbridge Road, West Ealing, W.13. An enjoyable evening is assured to anyone who attends. Particulars may be obtained from the Hon. Secretary, H. A. Williamson, 22, Cambourne Avenue, West Ealing, W.13.

B.T.S. Four-Band All-Wave Tuning Unit

SPECIFIED for the RECORD All-Wave 3

MR. F. J. CANN used this new B.T.S. production in the Author's version of his Record All-Wave 3, and exclusively specifies it for use by all who seek to duplicate exactly his success. Here is a self-contained highly efficient coil unit covering four wavebands (approx. 16-29, 27-57, 200-550, 900-2,100 metres), offering the Constructor facilities for the production of an All-wave receiver up to commercial standard. That's why Mr. Cann used no other, and why you should use no other. There is no substitute—a successful Record All-Wave 3 means a B.T.S. Tuning Unit **25/-** Type 4BTU

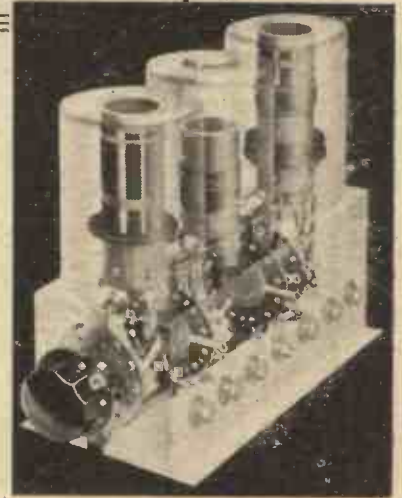

NOW READY!

The B.T.S. Booklet of 10 new tried and tested Short-wave and All-wave Circuits. Twenty-four pages, with theoretical circuits and complete wiring diagrams. Sent free to all sending name and address and 1½d. in stamps to cover postage.

ALL DEALERS STOCK B.T.S. PRODUCTS. If any difficulty, send cash direct, with name and address of your usual or nearest dealer.

"SHORT WAVE CONSTRUCTOR" No. 2, the B.T.S. magazine containing details of three new circuits and engrossing articles on S.W. Reception, is now obtainable from all dealers, W. H. Smith and Son's branches, price 3d., or direct from British Television Supplies, Ltd., post free 3d.



BRITISH TELEVISION SUPPLIES LTD. 8, Charing Cross Rd., London, W.C.2

Practical and Amateur Wireless

SERVICE DATA SHEET NO. 25

FOR THE BANDSPREAD THREE

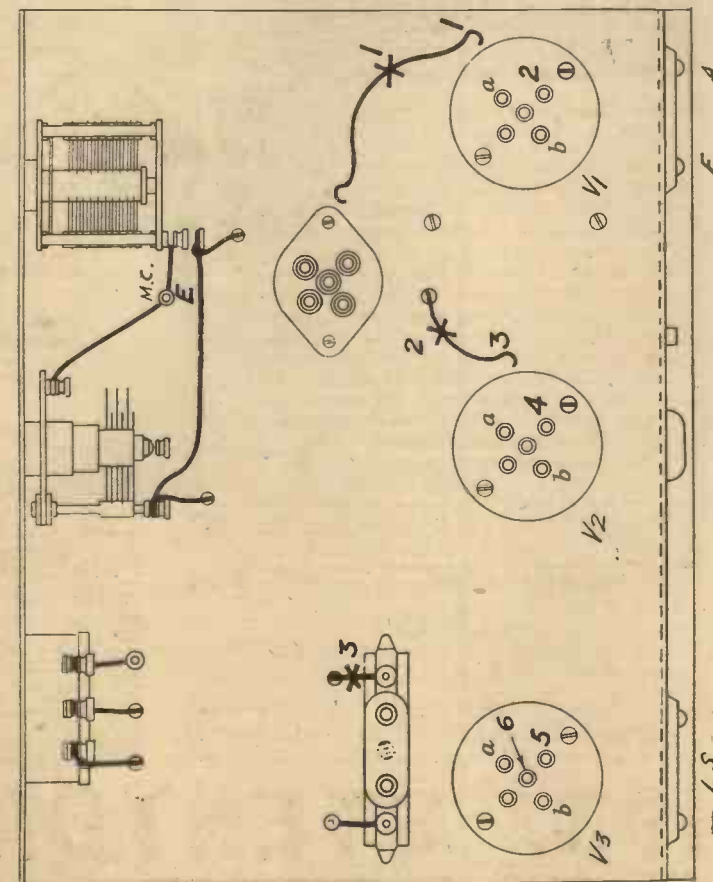

Top of Chassis View

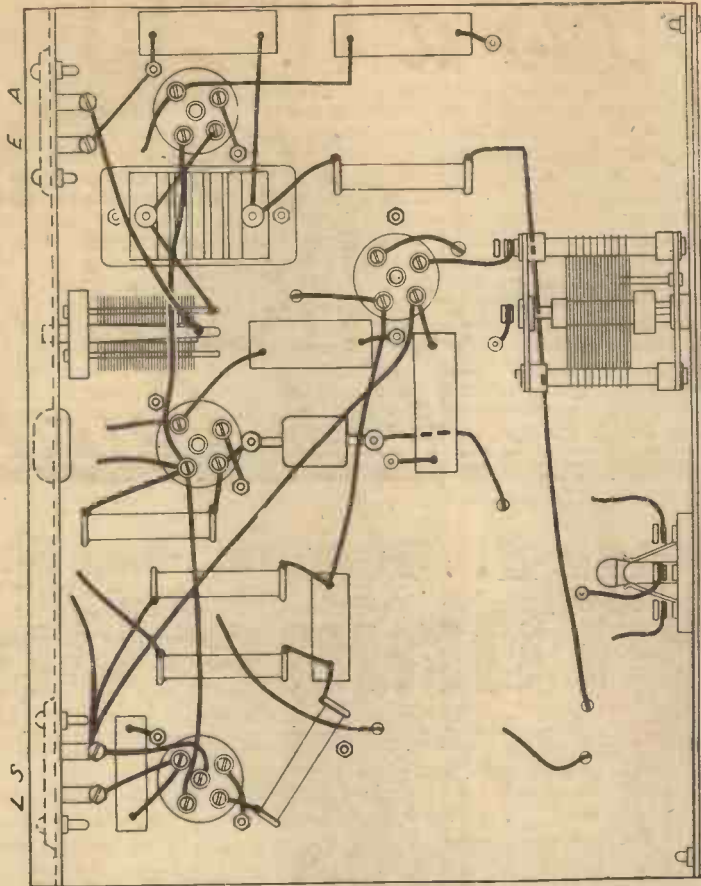

Underside of Chassis

Approximate Voltage Readings

Voltmeter — to E
” + to 1 = 120 volts.
” + to 2 = 100 volts.
” + to 3 = 45 volts.
” + to 4 = 36 volts.
” + to 5 = 115 volts.
” + to 6 = 120 volts.
” to a and b = 2 volts.

**TO TRACK THAT FAULT
AND FIND A REMEDY—**

READ
“EVERYMAN’S WIRELESS BOOK”
 3/6, by post 3/10, from George Newnes, Ltd.,
 8-11, Southampton Street, Strand, W.C.2.

Approximate Current Readings

Milliammeter Connected at x1 = 2 mA.
” at x2 = 1 mA.
” at x3 = 9 mA.

Voltage at point 2 can be increased to 120 volts
 with consequent increase of approximately 1 mA
 at x3.

REPLIES IN BRIEF

The following replies to queries are given in abbreviated form either because of non-compliance with our rules, or because the point raised is not of general interest.

J. S. (Morsham). The trickle charger described in our issue dated February 8th, 1936, will meet your requirements and details are there given concerning the lamps.

W. P. (Nr. Hatfield). We cannot assist you much without further details. Is the receiver correctly ganged? You cannot obtain results until this operation has been correctly carried out.

L. S. (Leicester). An ordinary H.T. eliminator is unsuitable. You will have to obtain details from the makers concerning the correct method of operating the speaker. It is necessary to know the correct field resistance and the wattage at which it is intended to operate.

R. M. (Vange). We regret that we cannot give instructions in the form of a reply for winding push-pull transformers or similar components. Details of the stampings must be supplied in order to work out the correct windings.

P. T. LeF. (Gaza). We have published short-wave coil winding data in our issue dated May 9th last. Details have been given from time to time concerning various broadcast coils.

H. M. (Buiwell). It may be necessary to experiment to find the best arrangement, but from your sketches we think the inverted "L" arrangement would be best. The down lead should be kept as far away from the wall as is convenient.

B. M. (Edgware). We cannot recommend any S.W. receiver to come lower than the figure you mention. Unless, of course, you are content with a very simple one-valver, the valves and batteries alone would cost the amount mentioned.

E. R. (Leeds). The only receiver designed round the coils named by you is now obsolete and no blueprints or other details are available.

G. B. (Hornchurch). Blueprint PW. 48A should be suitable for your needs, but you should inquire from the makers of your set whether it is suitable for use with a standard S.W. converter.

M. H. (Whitland, Carm.). We have no blueprints of a battery amplifier of the type mentioned. The only amplifiers providing an output of 5 watts or so are A.C. mains operated.

L. E. C. (Norwich). You do not mention whether you have the battery or mains version. In the former case the addition of the band-pass coil as detailed in our issue dated May 2nd last would no doubt be advisable in your case.

R. H. H. (Anerdaron). We regret that all issues describing the receiver are now out of print. We have no blueprint of this receiver now in stock.

F. K. (Birkenhead). The circuit as sketched by you is quite incorrect. Your aerial circuit is untuned; the second valve has no H.T. owing to the condenser in the anode lead; the H.T. is applied to the grid of the L.F. valve and the G.B. battery is short-circuited. Are you using the receiver in the form illustrated, or have you made some mistake in copying out the wiring?

A. J. S. (Dorking). The coil which was specified is no longer obtainable, but any good modern coil may be used in this crystal receiver.

E. H. S. (Tiverton). An alteration in the H.T. applied to the screen may help matters. We favour a triode used in the usual manner in this particular circuit.

T. P. (Birkenhead). In view of the switch difficulty, we suggest you return the coil unit to the makers for test. The value of C5 is mentioned in the text. It is not a condenser which has to be purchased, but is made up from two lengths of wire twisted together. It is clearly shown on the blueprint.

N. N. E. (Tyrone). Generally speaking, there is no difference in the two components. In certain high-class apparatus, however, the S.G. transformer would be wound with a higher inductance primary. The 60X coil referred to may be wound on a 3in. diameter former, using 60 turns of 22 d.c.e. wire and tapping at the 5th, 10th, and 30th turns from the earthed end.

W. H. (E.14). The oscillation referred to by you is undoubtedly H.F. instability and is not due to the reaction circuit at all. It will be necessary to improve the layout of the H.F. stage and check the voltages applied. As an eliminator is in use it would be worth while trying the set with an ordinary battery supply in order to obtain good results as the eliminator may be unsuitable without otherwise modifying the circuit.

H. E. (Cleethorpes). The device referred to may prove of use, but we suggest you study the article in this issue on Breakthrough before going to the expense of buying any new apparatus.

D. H. (Bracknell). The trouble may be due to a faulty valve or a bad connection in the receiver. We suggest you have it inspected by a local service agent of the company who made the receiver.

J. H. J. (Heaton Park). Although a battery could be included in series with the mike and speaker, better results will be obtained if you use the pick-up terminals, as then you obtain the additional amplification of the valve stages.

Now a new Stentorian and a new High Quality!



IN place of a detailed explanation of the multitudinous small improvements which bring the 1937 Stentorian's new sensitivity and fidelity, the reproduction curves below (taken from the 1936 and 1937 Stentorian senior chassis) are published for your inspection.

Even if you have a 1936 Stentorian (by far the finest commercial speaker available till now) this new instrument, embodying a further year's discoveries, will improve your set by just the same margin as the curves show. If you are using any other, then the difference this new speaker brings will be a positive revelation to you.

In fairness to yourself, hear one! Your dealer has the new chassis in stock, and will gladly demonstrate. Ask him—to-day!

Models at 39/6 and over available on H.P. from

7/6 DOWN.



Read this message from Mr. F. J. Camm:—

"Once again I can confirm the claims of your engineers to have enhanced even further the already enviable reputation which your speakers enjoy. The 1937 Stentorian, which I have submitted to a thorough test, represents a marked advance on your previous models. If anything, your claims are too modest, for my curves show a greater degree of frequency response at both ends of the register. Last year I asked 'Can there be a better speaker?' Your 1937 Stentorian Speaker supplies the affirmative answer. All listeners, and particularly constructors, owe a debt of gratitude to the indefatigability of your research engineers."

F. J. Camm

Better volume on weak stations, new clear top notes free from shrillness, full colourful bass without "thump" and a surprisingly incisive realism are available to you—at moderate cost. For a reasonable deposit (from 7s. 6d. upwards) you may have from your radio an entertainment quality you have never attained before! Hear this new speaker, and know what 1937 reproduction can be!

PRICES

CABINET MODELS		CHASSIS MODELS	
37 SC (Senior) ..	63/-	37 S	42/-
37 JC (Junior) ..	49/6	37 J	32/6
37 CC (Cadet) ..	39/6	37 B	23/6
37 BC (Baby) ..	29/6	37 M	17/6
Duplex	£3 6	EMJW	70/-
		Duplex	74/-

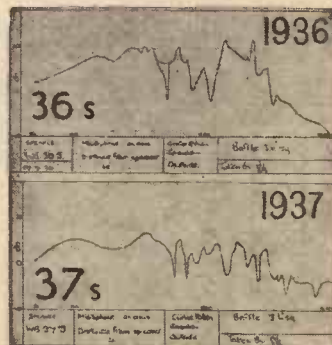

THE PRACTICAL MOTORIST
3d. Every Friday

1937 STENTORIAN

PERMANENT MAGNET MOVING COIL SPEAKERS
Whiteley Electrical Radio Co. Ltd. (Technical Dept.), Mansfield, Notts.

Facts and Figures

COMPONENTS TESTED IN OUR NEW LABORATORY

Wearite "I.C." Coils

A SERIES of low-priced screened iron-core coils may be obtained from Messrs. Wright and Weaire, suitable for any type of receiver. As may be seen from the illustration below the medium and long-wave sections of the coil are arranged at right angles and the coils are both wave-wound and sectional wound to obtain maximum inductance and efficiency. The ends of the windings are firmly anchored to soldering tags eye-letted into the insulating supports, and the small diameter formers contain a standard iron core. The windings are standardised

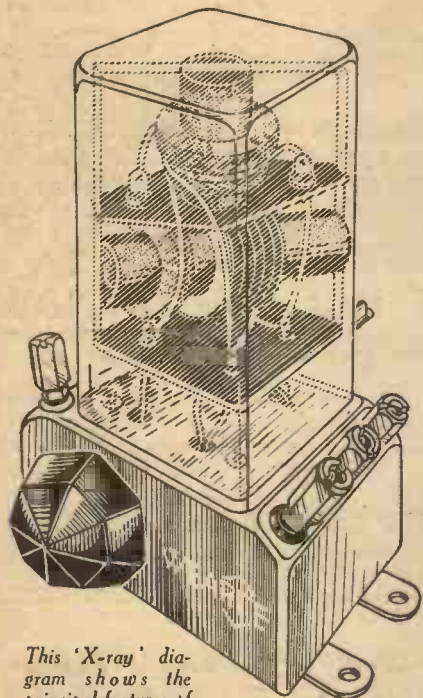

This 'X-ray' diagram shows the principal features of the Wearite "I.C." coils. Note the method of arranging the separate sections at right angles.

to the values now adopted by the Component Manufacturers Federation, and thus the coils may be arranged in combinations and satisfactorily ganged with modern tuning condensers. The types available are simple Aerial coils, Band-pass pairs, Grid coils, and H.F. transformers, with or without reaction windings, and the price in each case is 7s. 6d. The base of each coil contains a wave-change switch and the switch rods are extended so that they may be coupled when two or more coils are employed, and the wave-change mechanism thereby operated from a single control on the panel.

Belling-Lee Anode Splitter

TO test the working characteristics of a valve the insertion of a milliammeter in the anode circuit is the most direct method to adopt, and in the ordinary type of valve a split-anode adapter may be inserted between the valve and the valve-holder. With an S.G. or H.F. pentode type of valve, the meter may be joined between the anode cap, and with the

terminal type of cap this is not difficult. The latest types of S.G. and H.F. valve are, however, in many cases provided with a solid pin, and connection is obtained by means of a spring connector and this renders the breaking of the anode lead at this point rather difficult. To overcome any problem which may arise in this connection, Messrs. Belling and Lee have now produced a screen grid anode-splitter, the general arrangement of which is shown in the sketch on this page. An insulated sleeve contains the usual metal plug with three silver plated spring lips to grip the anode plug. A twin lead is internally connected to the spring grip and the extension plug, and to the ends of the lead (which is 24ins. long) two spade terminals are joined. These are lettered

A novel idea introduced by Belling-Lee for the inclusion of testing apparatus, etc., in the anode lead of S.G. valves fitted with plug tops.



Anode and H.T.+ to avoid mistakes in connecting meters, etc. The usual connector fitted to the receiver is removed from the anode plug, the Anode Splitter is placed on the plug, and the lead is replaced on top of the splitter, when the meter, etc., may be joined to the two spade ends and thus becomes automatically joined in the anode circuit. The price is 1s. 6d.

Lissen Hi.-Q. I.F. Unit

AMONGST the many new Lissen high-efficiency short-wave components is a novel I.F. unit and ultra-short-wave H.F. choke, both of which are here illustrated. The I.F. Unit is a tuned-anode coupling device for an intermediate frequency of 50 kc/s, and is specially designed for circuits incorporating the Lissen rotary coil unit. It consists of a coil and parallel condenser, with the addition of a resistor, one end of which is joined to the condenser and coil, but the other end is carried out to a socket. Attached to the "free" end of the coil and condenser combination is a flexible lead terminating in a wander plug, and thus the resistor may be joined in parallel with the tuned circuit when it is desired to damp it for reducing the sharpness of tuning. Terminal connecting points are provided for H.T. and anode leads, and the sockets marking the end of the resistor and a free point for the plug are marked, respectively, "low" and "high." The price is 7s.

The ultra-short-wave choke has an inductance of 100 microhenries

and is wound astatically, with the winding split up into solenoid and wave-wound sections to preserve efficiency on various wavebands. The price is 2s., and this component may be either suspended in the wiring or mounted on the baseboard, for which purpose bolts are fitted to the ends of the former.

Heyberd "Tom Thumb" Charger

A NEAT, small charger, suitable for 2-volt accumulators has been recently introduced by Messrs. Heyberd, and its size has resulted in the name "Tom Thumb." The actual dimensions are 3½ins. by long 2½ins. wide and 3½ins. high, and it will provide half an amp. for charging purposes. The input is a double wound transformer, and a standard metal rectifier is employed for rectification purposes. The output terminals are insulated, and a mains flex is fitted with a mains plug. The case is of metal, adequately ventilated, and no possibility of shocks or damage can arise if the unit is correctly used. The price of this neat charger is 12s. 6d.

Ever Ready Radio Change of Address

THE new address of Ever Ready Radio Ltd. and Ever Ready Radio Valve Co. Ltd., is Hercules Place, Holloway, London, N.7. This new address has been in force since October 19th last.

Bulgin I.F. Liner

AN interesting new liner is announced by Messrs. Bulgin, and although designed primarily for the service engineer the ordinary amateur will no doubt find it of great use when a superhet is built or where such a receiver has become upset so far as ganging is concerned. This new device is a neon oscillator which may be used to adjust the I.F.'s and avoids the necessity of a complicated signal generator. Further details will be given when they are available, but we are able to announce that the price will be 12s. 6d.

New Radio Hire Service

A NEW development in radio renting is announced by Warners Radio and Electric, Limited, 39, Leonard Street, E.C.2, whereby the latest Marconi models are to be available for hire at a small weekly rental which includes installation, servicing and insurance. The renting period is terminable at any time by the hirer, who also has the right to purchase, all rental payments being credited against the purchase price.

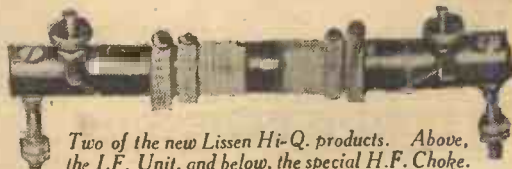

Two of the new Lissen Hi-Q products. Above, the I.F. Unit, and below, the special H.F. Choke.

BULGIN

QUALITY COMPONENTS

1/2 WATT RESISTORS

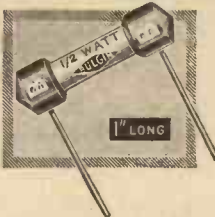

You can halve your costs with these 1/2 watt wire-end miniature resistors, for in 80% of the positions in a modern receiver this size is electrically sufficient. Accurate and reliable, they are specified for the "Record". All-wave Three in this issue.

A large range comprising 36 values is obtainable, covering from 100 ohms to 5 megohms. All types are closely accurate. Price 6d. each.



VOLUME CONTROL
Really smooth control of volume can be obtained with these Bulgin Compact Volume Controls with 3 pt. switches. Squash-plate action, wire-wound elements and 3 pt. switching automatically operated by rotation of the control knob.

List No. V.M.36, specified in this issue. Price 5/6 each.

MIDGET TRANSFORMER

An uncased midget L.F. Transformer for use in pocket or portable sets and where quality is a consideration. Although chiefly intended for fed connection it may be directly connected if the steady anode current does not exceed 1.5 mA. For baseboard or chassis fixing. List No. L.F.33.

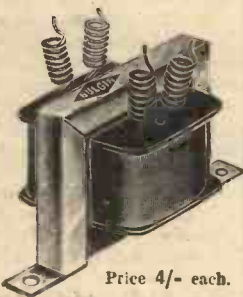

Price 4/- each.

FOR H.F. SEALED CHOKES

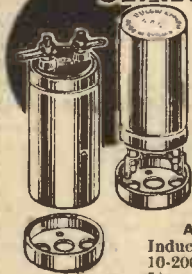

These Bulgin H.F. Chokes are hermetically sealed in spun-metal cans. Peakless in performance, with high inductance and low self-capacity.

ALL-WAVE (Specified)
Inductance 150,000 μ H. Range 10-2000 m. List No. H.F.15. 5/- each.

POPULAR
Inductance 198,000 μ H. Range 200-2000 m. List No. H.F.18. 2/3 each.

STANDARD
Inductance 250,000 μ H. Range 180-2000 m. List No. H.F.19. 3/3 each.

SUPER
Inductance 500,000 μ H. Range 150-2,500 m. List No. H.F.20. 4/3 each.

To A. F. BULGIN & CO., LTD., Abbey Rd., Barking, Essex.

Please forward Post Free a copy of your Complete Catalogue No. 156N, 2nd edition, for which I enclose 3d. stamps.

Name
Address

N (Please use Block Letters.)
SEND THIS COUPON

**DISTORTION
LOSS OF POWER
LACK OF SENSITIVITY**

**Make yours
a new set**

**HIVAC
THE SCIENTIFIC
VALVE**

For the fraction of the cost of a new set you can, by replacing 'tired' valves with their modern equivalents, not only restore the original quality of your set, but actually give it a higher sensitivity and greater power output than it originally possessed.

Investigations prove that 'tired valves' are responsible for the general deterioration of otherwise perfectly good sets. Your dealer will confirm this if you let him test your old valves.

HIVAC have produced a special valve Replacement Chart which shows the correct HIVAC type to replace those worn out. HIVAC valves, as used in the latest receivers, are highly efficient, give long service and cost less.

The sure and economical way to get the best from your set is to replace all 'tired' valves with HIVAC.

POST THIS COUPON NOW

Please send me HIVAC replacement Chart "N"

Name

Address

THE HIGH VACUUM VALVE CO., LTD.,
111/117, Farringdon Road, London, E.C.1.

Cut out Coupon, place in unsealed envelope or paste on postcard. Postage on either is Halfpenny. "N" 1.

ENGINEERS! ARE YOU EARNING LESS THAN £10 PER WEEK?

If so, you cannot afford to carry on without reading our 268-page Handbook. The book explains clearly and definitely many ways of carving out a successful career. Among other things it explains the Services of our unique Appointments Department, outlines Home-study Courses in all branches of Civil, Mechanical, Electrical, Motor, Aero, Wireless, "Talkie," Engineering, Building, Govt. Employment, etc., and gives details of B.Sc., A.M.I.C.E., A.M.I.E.E., A.M.I.Mech.E., A.M.I.A.E., A.M.I.W.T., A.M.I.R.E., G.P.O., MATRIC, and all Exams. We Guarantee—"NO PASS—NO FEE." Whether you be an old hand or a budding apprentice, get this book to-day—FREE and POST FREE, BRITISH INSTITUTE OF ENGINEERING TECHNOLOGY.



409, Shakespeare House, 17/19, Stratford Place, London, W.1.

PATENTS AND TRADEMARKS.

KINGS PATENT AGENCY (Director: B. T. King, Patent Agent). Advice, Handbook and Consultations free.—146A, Queen Victoria Street, E.C.4. Phone: City 6161.

FREE ADVICE BUREAU COUPON

This coupon is available until November 7th, 1936, and must be attached to all letters containing queries.
PRACTICAL AND AMATEUR WIRELESS,
31/10/36.

Exceptional Offer

ELECTRIC SOLDERING IRONS

A necessity in every Workshop, Factory and Home. Suitable A.C. or D.C. Makes soldering a simple task. Sold under guarantee of satisfaction or we will refund the entire purchase price.

Made to sell at 15/8. We offer manufacturers entire stock at less than manufacturing costs.
Light-weight Model, usual price, 12/6. Now offered at 4/9, Post Free. State voltage when ordering.
ORDER YOURS TO-DAY WHILE THEY LAST?
G.P. Co., 73a, Cumberland St., Edinburgh. Dept. F.

OUR PRICE 5/9 POST FREE

RECORD

The quality valve in the COMPLETE range

RECORD RADIO LTD., 2/3, Eldon Street, E.C.2

LETTERS FROM READERS

The Editor does not necessarily agree with opinions expressed by his correspondents.



All letters must be accompanied by the name and address of the sender (not necessarily for publication.)

Logged on our Two-valve Short-waver

SIR,—As I have not yet seen a S.W. log from this district, I enclose mine. The set used was a 2-valve simple receiver which appeared in your issue of July 18th, 1936, but instead of a pentode I am using a power valve, and the aerial used is 50ft. long, and about 30ft. high. I made my own choke with a piece of fountain pen, and I wind my own coils. Broadcast stations: SM5SX, 2RO, Belgrade, W3XAL, W8XK, W2XE, W1XK, W2XAF, W1XAL, W2XAD, GSG, GSB, PJC, HAT4, COCH, COCD, VK2ME, DJI, DJA, DJN, CT1AA, EAQ, Moscow. On 40 metres, about 50 to 60 amateurs, foreigners and British. On 20 metres, CO6OM, W3APO, W1UH, W4BYY, G5NI, W9RES, W1CHG, W30FZ, W8IGL, E16G, W5MD, W6FTY, YU4AA, W1BQN, W2ZC, ON4BK, W2BX, W9KLL, W9PD, and ON4ID.

Wishing PRACTICAL AND AMATEUR WIRELESS every success.—F. HOPKINS (Newbridge, Mon).

Good Results with the "Septimetre"

SIR,—May I take this opportunity to let you know that I have built your ultra-short-wave set, the "Septimetre," particulars of which were published in a recent issue of PRACTICAL AND AMATEUR WIRELESS. I had the pleasure of trying it on the air last week-end, and as I have never worked below 16 metres before, I must say I am well satisfied with the results, and am proud to be the owner of such a fine set.

I would gladly recommend this set to anyone who wants to make a start on the ultra-short waves.

By the way, I am rather surprised that more readers do not submit logs for 10 metres and below, because I think that reports on 10-metre and 5-metre stations would be met with a QSL card from most amateurs, providing a good detailed report is sent in. I would be glad to correspond with any reader interested in short waves.—A. BLAKELEY (61, Laurel Avenue, Newton-le-Willows, Lancs).

Proposed Short-wave Club for Edinburgh

SIR,—Looking through the different issues of PRACTICAL AND AMATEUR WIRELESS, one finds reports from short-wave societies concerning their activities. I, and no doubt others in this district, have often wished for a club of this sort. I suggest that all the members, and intending members, of the B.L.D.L.C. in this district, should join up and form the much-desired club. I would gladly turn over the secretaryship to an older person, but if no one volunteers, I would undertake to manage the affairs at the start. If all short-wave listeners would pull together I am sure the club would grow into a fairly large concern. The subscription would be enough to have a meeting place, and all the sundries necessary. There would be numerous activities, such as field days, talks, demonstrations, etc., and perhaps some of the nearby amateurs would give lectures on different subjects. The organising of the club could be done by voting,

and the club would, of course, be a branch of the B.L.D.L.C. I shall be glad if interested readers would get in touch with me at the address given below.—STUART D. KEEBLE (118, Craiglea Drive, Edinburgh, 10).

A Good Short-wave Log from Mill Hill

SIR,—Although a regular reader of your most interesting paper, I have not yet noticed a report from North-west London, and, consequently, the following log may be of interest to other readers. The stations mentioned below have been picked up during the present year on an o-v-2 receiver with a 20ft. dipole aerial about 21ft. high. All reception was on 'phones.

Amateurs (20 metres): 118 U.S.A., also VP2CD (Antigua), VK2ABD, 2QR, 2VR, PY2BA, 2CK, 2EJ, VE1BR, 1CH, 1CN, 1CR, 1DC, 1DG, 1EA, 1GH, 2BG, 2CA, 2HM, 2MB, 3JV, 3NF, NY2AE (Canal Zone), CO2HY, CO8RQ, HI7G, HI5X, VO1J, VO1I, VO4Y, SU1CH, 1KG, 1SG, SM5SX, HB9A, and HKK.

On 40 metres: 190 G stations and forty Europeans. On the broadcast bands: 112 stations, including TGW, HJU, VUB, VK2ME, VK3LR, JVH, JVM, JVP, HP5J, HP5B, VP3MR, PMN, HIX, HIZ, CRCX, and also COCD-E-H-Q-O, CO9JQ, and CO9GC.—DOUGLAS L. PELHAM (Mill Hill, Middlesex).

S.W. Experiences

SIR,—Six months ago I was rather dubious about this S.W. business, but I eventually decided to buy a S.W. superhet converter to find out what it was all about, and I am glad I did. I soon found out that I could get more thrills from my set than ever before. Did I get a thrill in listening to stations in N. America, S. America, Cuba, Japan, Canada, Australia and dozens of others from all parts of the world?

I think my biggest thrill came from listening to the 20 m. "hams," some of these fellows only using enough power to run an electric bulb; it's amazing the way they "get across" from incredible distances. One "ham" I heard from Australia was only using 20 watts input.

I have tried to spend one hour every evening listening to these fellows on 20 m., usually from 23.30 to 00.30. I have, of course, listened at other times, but I have tried to make this hour a regular "sked."

I suppose I have listened at this hour for five out of the six months, and I have heard at least 330 "hams."

I wonder if one of your readers can identify SB9BK?

I have just received a card from SM5SX and he asked me if I would be so good as to inform all other listeners who sent him

THE ONLY STANDARD WORK!

**WIRELESS CONSTRUCTOR'S
ENCYCLOPÆDIA.**

5/- or 5/6 by post from

Geo. Newnes, Ltd., 8-11, Southampton Street, Strand,
London, W.C.2.

reports, that they would receive their cards as soon as possible. The reason for the delay is that he has received over 2,000 reports in three months and he is finding it a heavy and rather expensive job answering them.

My set is a 4-valve superhet with a S.W. superhet converter. I am now building a 2-valve set for headphone reception.

The aerial is 100ft. long. One end is fastened to top front window of house (which faces south), the other end is dropped down to the basement (about 40ft. semi-vertical) and then brought in through the window and around the room to the set.

I have received quite a few QSL cards without sending return postage, and I think any "ham" will send a card providing you give details of set, antennæ, location, weather conditions, etc., with the report on his signals.

I wish to thank you for your valuable aid and prompt answers of the queries I have sent you.—H. L. (Plymouth).

Cuban Transmissions

SIR,—In "Leaves from a Short-wave Log" of October 10th you remark upon a "Cuban puzzle," namely, COCX (25.7 m.).

On August 26th last I first logged this Cuban and gathered the following details:—

Programme for each thirty minutes: Rumba; Announcements (in Spanish); Rumba or foxtrot; Chimes, etc., and call (in Spanish). The Call was: "Onda Larga CMX, Onda Corta COCX, Habana, Cuba." The signals were: Five chimes (three single and one double) and a railway engine whistle. The programme, which lasted from 05.00 to 07.10 (B.S.T.) was a steady R9 on 'phones. The "Closing Call" was given in English and was: "This is COCX, good-night everybody."

The only other time I logged COCX was on August 29th at 06.00 B.S.T., when I heard the chimes and call (in English). The receiver used was an S.G.-v-2 with a 15ft. indoor aerial. Hoping this will be of interest to other readers.—J. LILLYWHITE (B.L.D.L.C. 2620) (Shoreham-by-Sea).

CUT THIS OUT EACH WEEK.

Do you know

—THAT the acid in an accumulator may be jellified by adding Sodium Silicate.

—THAT shorted turns on an H.F. choke will prevent it from carrying out its function and will result in erratic reaction effects.

—THAT although a push-pull stage will function when one valve is removed, this should not be done in the case of a mains receiver employing automatic grid bias.

—THAT the feeder leads from a dipole aerial may be either carried parallel or twisted throughout their length.

—THAT the waveband covered by a tuning coil may be modified by moving the end turns, or by placing a metal screen near the coil.

—THAT in a powerful self-contained receiver, vibration from loud signals may result in a form of fading due to vibration of the tuning condenser.

The Editor will be pleased to consider articles of a practical nature suitable for publication in PRACTICAL AND AMATEUR WIRELESS. Such articles should be written on one side of the paper only, and should contain the name and address of the sender. Whilst the Editor does not hold himself responsible for manuscripts, every effort will be made to return them if a stamped and addressed envelope is enclosed. All correspondence intended for the Editor should be addressed: The Editor, PRACTICAL AND AMATEUR WIRELESS, George Newnes, Ltd., 8-11, Southampton Street, Strand, W.C.2.

Owing to the rapid progress in the design of wireless apparatus and to our efforts to keep our readers in touch with the latest developments, we give no warranty that apparatus described in our columns is not the subject of letters patent.



QUERIES and ENQUIRIES

Auto Grid Bias

"Can ordinary mica or paper dielectric condensers be used for purpose of applying grid bias to the output valve in a battery receiver? If so, what are the most suitable values to use? Would the resistor be the same value as that used in conjunction with the usual electrolytic? Bias voltage required, 4½ volts."—R. W. C. (S.W.4).

THE condenser itself does not apply bias, but is merely used as a by-pass across the resistor. The bias voltage is obtained by virtue of a voltage drop across the resistor, and this voltage is thus dependent upon the current flowing through it (Ohms Law). The value of the resistor therefore depends upon the voltage required for bias and the current which flows. In a battery receiver with a single L.F. (output) stage, the resistor is connected in the H.T. negative lead and therefore the current is the total of all of the valves in the receiver. To ascertain the correct value of resistor, use ordinary battery bias of the correct value and then connect a milliammeter in the H.T. negative lead. This will give the current flowing, and by dividing it into the bias voltage and multiplying the answer by 1,000 you will have the value of the resistor in ohms. The by-pass condenser may consist of either a paper dielectric or electrolytic condenser, and any value above 2 mfd. may be used—the higher the value the better the bass response in the majority of cases.

Superhet Failure

"I have constructed a 4-valve superhet (Heptode, Var.-Mu, I.F., D.D.T., and Pentode Output). I have checked every resistance and coil with a megger and substituted all the fixed condensers, but I can find nothing wrong, and yet the volume is very weak. I had more volume from my previous straight 3 portable. Could you please help me in this matter as to what is likely to be wrong? Would it be possible to add a mains amplifier to the original set and operate the latter from a battery eliminator?"—G. U. (Tottenham).

IF the coils and resistors are in order, and condensers have been replaced, then failure to obtain good results must be due to faulty valves or incorrect adjustment of the receiver. Valves may be checked by substitution in some cases, but a good radio dealer may be able to provide a more satisfactory check. If, of course, the oscillator coil is for one I.F., and the intermediate-frequency transformers are for another, you will not obtain satisfactory working, and you should therefore check that the coils and I.F. trans-

formers are designed for the same frequency. Furthermore, the ganged condenser should be checked to make certain that the oscillator section follows the correct law. Finally, all circuits must be correctly ganged, and the adjustment of the many tuned circuits of a superhet will not be found a very simple matter unless a standard arrangement is followed. You could operate the receiver from the mains and use a mains amplifier without any difficulty, but you should get the set working correctly first.

Pick-up Problem

"In a recent issue you stated that the pick-up should be correctly mounted and explained that it should remain indefinitely on the clear part of the record near the edge whilst the record rotated when correctly set. I adjusted my motor for this position, but later obtained a spirit level and then found that the turntable was not level.

RULES

We wish to draw the reader's attention to the fact that the Queries Service is intended only for the solution of problems or difficulties arising from the construction of receivers described in our pages, from articles appearing in our pages, or on general wireless matters. We regret that we cannot, for obvious reasons—

- (1) Supply circuit diagrams of complete multi-valve receivers.
- (2) Suggest alterations or modifications of receivers described in our contemporaries.
- (3) Suggest alterations or modifications to commercial receivers.
- (4) Answer queries over the telephone.
- (5) Grant interviews to quicrists.

Please note also, that queries must be limited to two per reader, and all sketches and drawings which are sent to us should bear the name and address of the sender.

If a postal reply is desired, a stamped addressed envelope must be enclosed. Send your queries to the Editor, PRACTICAL AND AMATEUR WIRELESS, George Newnes, Ltd., 8-11, Southampton Street, Strand, London, W.C.2.

The Coupon must be enclosed with every query.

When correctly adjusted by the spirit level I find that the needle falls into the first groove rather heavily. As my records all wear out quickly at the first few grooves I should be glad to know which is the most conclusive test—the spirit level or the adjustment at the plain part of the record."—S. K. (Cairo).

IF the turntable is quite level the needle should remain on the plain edge indefinitely in spite of the centrifugal force which is exerted at that point.

TELEVISION AND SHORT-WAVE HANDBOOK

By F. J. CAMM

3/6 or 3/10 by post from

George Newnes, Ltd., 8-11, Southampton Street, Strand, W.C.2.

Failure to do so would indicate that the pick-up mounting is incorrect, and you may find that this is so arranged that in your case the pick-up is tipped towards the centre of the turntable, thus causing the needle to slide downwards. Adjust the turntable by means of your spirit level and then adjust the mounting foot of the carrier arm until the needle remains in the same position whilst the turntable revolves. If the needle is not then vertical when viewed from the front it will indicate that the pick-up has become twisted at the point where it joins the carrier arm, or the latter is twisted. In such a case return it to the makers for their report.

Batteries in Series

"In a 1933 issue you stated that two batteries could be used in series when more than one H.T. tapping is used, as the lower half of the battery becomes subject to a higher load and can thus be replaced at lower expense. Can I do this with my set, which requires 120 volts, and, if so, how do I get, say, 90 volts, for instance, or 80? Do I use the one 60 volt, for the 60-volt tapping and then plug in at 30 in the other battery to make 90 volts?"—W. P. (Plymouth).

THE arrangement you mention is quite correct, the 60-volt (positive) socket on one battery being joined to the negative socket on the other battery. Therefore, 60 volts would be obtained by connecting to the junction point of the two batteries, and 90 volts by inserting the plug into the 30-volt socket on the second battery. Although this arrangement does permit the lower half of the total battery to be replaced, there is a fallacy in the argument, due to the fact that the connection of a new battery in series with a partially-discharged one (the upper section of the dual battery) will not produce a full voltage, as a charging action will be found to take place from the new into the old battery. A much better idea to avoid the difficulties of the uneven load on a battery is to use a single H.T. lead, obtaining the lower voltage points in the receiver by the use of voltage-dropping or decoupling resistances.

Battery Charger

"I require a small charger for my car accumulator which I use for operating a continental home broadcast set fitted with a converter. What is the cheapest charger you can recommend. I cannot build one as I am not handy with tools, and would prefer a shop-made article with a guarantee. I have, of course, got mains facilities for charging."—R. E. (Weymouth).

A SUITABLE charger may be obtained from Messrs. Heayberd, of Finsbury Street, London, E.C.2. Models are obtainable for both 6-volt and 12-volt accumulators (you do not state the voltage of yours), and the price of Model V 12/5 or V 6/5 is 90/-. These both deliver 5 amps, are light and compact, and fool-proof in action.

The coupon on page 223 must be attached to every query.

TO MAKE YOUR SET REALLY SELECTIVE

FIX IN YOUR

A PIX can be fitted to any set—battery or mains. Just disconnect your aerial from the set and join it to one end of the PIX—connect the other end to the Aerial terminal. By opening the PIX you can cut out interfering stations and get the one you want.

RECEPTION CLEAR & FREE FROM INTERFERENCE



Practical and Amateur Wireless BLUEPRINT SERVICE

PRACTICAL WIRELESS STRAIGHT SETS. Battery Operated. One-valve : Blueprint, 1s.

Date of Issue.	No. of Blueprint
All-wave Unipen (Pentode)	PW31A
Two-valve : Blueprint, 1s.	
Four-range Super Mag Two (D Pen)	11.8.34 PW36B
Three-valve : Blueprints, 1s. each.	
Selectone Battery Three (D, 2 LF (Trans))	PW10
Sixty-Shilling Three (D, 2 LF (RC & Trans))	2.12.33 PW34A
Leader Three (SG, D, Pow)	PW35
Summit Three (HF Pen, D, Pen)	8.8.34 PW37
All Pentode Three (HF Pen, D (Pen), Pen)	22.0.34 PW39
Hall-Mark Three (SG, D, Pow)	PW41
Hall-Mark Cadet (D, LF, Pen (RC))	16.3.35 PW48
F. J. Camm's Silver Souvenir (HF Pen, D (Pen), Pen) (All-Wave Three)	13.4.35 PW49
Genet Midget (D, 2 LF (Trans))	June '35 PM2
Cameo Midget Three (D, 2 LF (Trans))	8.6.35 PW51
1036 Sonotone Three-Four (HF Pen, HF Pen, Westector, Pen)	17.8.35 PW53
Battery All-Wave Three (D, 2 LF (RC))	31.8.35 PW55
The Monitor (HF Pen, D, Pen)	8.2.36 PW61
The Tutor Three (HF Pen, D, Pen)	21.3.36 PW62
The Centaur Three (SG, D, P)	PW64
The Gladiator All-Wave Three	29.8.36 PW66
Four-valve : Blueprints, 1s. each.	
Fury Four (2 SG, D, Pen)	PW11
Beta Universal Four (SG, D, LF, Cl, B)	15.4.33 PW17
Nucleon Class B Four (SG, D (SG), LF, Cl, B)	6.1.34 PW34B
Fury Four Super (SG, SG, D, Pen)	PW34C
Battery Hall-Mark 4 (HF Pen, D, Push-Pull)	PW40
F. J. Camm's "Limit" All-Wave Four (HF Pen, D, LF, P)	26.9.36 PW67

Mains Operated.

Two-valve : Blueprints, 1s. each.	
A.C. Twin (D (Pen), Pen)	PW18
A.C.-D.C. Two (SG, Pow)	7.10.33 PW31
Selectone A.C. Radiogram Two (D, Pow)	PW19
Three-valve : Blueprints, 1s. each.	
Double-Diode-Triode Three (HF Pen, DDT, Pen)	10.6.33 PW23
D.C. Ace (SG, D, Pen)	15.7.33 PW25
A.C. Three (SG, D, Pen)	PW29
A.C. Leader (HF Pen, D, Pow)	7.4.34 PW35C
D.C. Premier (HF Pen, D, Pen)	31.8.34 PW35B
Ubique (HF Pen, D (Pen), Pen)	28.7.34 PW36A
Armada Mains Three (HF Pen, D, Pen)	18.8.34 PW38
F. J. Camm's A.C. All-Wave Silver Souvenir Three (HF Pen, D, Pen)	11.5.35 PW50
"All-Wave" A.C. Three (D, 2 LF (RC))	17.8.35 PW54
A.C. 1936 Sonotone (HF Pen, HF Pen, Westector, Pen)	31.8.35 PW56
Four valve : Blueprints, 1s. each.	
A.C. Fury Four (SG, SG, D, Pen)	PW20
A.C. Fury Four Super (SG, SG, D, Pen)	PW34D
A.C. Hall-Mark (HF Pen, D, Push-Pull)	PW45
Universal Hall-Mark (HF, Pen, D, Push-Pull)	0.2.35 PW47

SUPERHETS.

Battery Sets : Blueprints, 1s. each.	
£5 Superhet (Three-valve)	PW40
F. J. Camm's 2-valve Superhet (Two-valve)	18.7.35 PW52
F. J. Camm's £4 Superhet	PW58
Mains Sets : Blueprints, 1s. each.	
A.C. £5 Superhet (Three-valve)	PW43
D.C. £5 Superhet (Three-valve)	1.12.34 PW42
Universal £5 Superhet (Three valve)	PW44
F. J. Camm's A.C. £4 Superhet 4.	PW59
F. J. Camm's Universal £4 Superhet 4	11.1.36 PW60

SHORT-WAVE SETS.

Two-valve : Blueprint, 1s.	
Midget Short-Wave Two (D, Pen)	15.9.34 PW38A
Three-valve : Blueprints, 1s. each.	
Experimenter's Short-Wave Three (SG, D, Pow)	PW30A
The Perfect 3 (D, 2 LF (RC and Trans))	8.2.36 PW63
The Bandsread S.W. Three (HF Pen, D (Pen), Pen)	20.8.36 PW68

PORTABLES.

Three-valve : Blueprint, 1s.	
F. J. Camm's ELF Three-valve Portable (HF Pen, D, Pen)	16.5.36 PW65

Four-valve : Blueprint, 1s.	
Featherweight Portable Four (SG, D, LF, Cl, B)	PW12

MISCELLANEOUS.

S.W. Converter-Adapter (1 valve)	PW48A
--	-------

AMATEUR WIRELESS AND WIRELESS MAGAZINE CRYSTAL SETS.

Blueprints, 6d. each.	
Four-station Crystal Set	AW427
1934 Crystal Set	AW444
150-mile Crystal Set	AW450

STRAIGHT SETS. Battery Operated.

One-valve : Blueprints, 1s. each.	
B.B.C. Special One-valver	AW387
Twenty-station Loud-speaker One-valver (Class B)	AW440

Two-valve : Blueprints, 1s. each.	
Melody Ranger Two (D, Trans)	AW388
Full-volume Two (SG det, Pen)	AW392
B.B.C. National Two with Lucerne Coil (D, Trans)	AW377A
Big-power Melody Two with Lucerne Coil (SG, Trans)	AW338A
Lucerne Minor (D, Pen)	AW426
A Modern Two-valver	July '36 WM409

Three-valve : Blueprints, 1s. each.	
Class-B Three (D, Trans, Class B)	22.4.33 AW386
New Britain's Favourite Three (D, Trans, Class B)	15.7.33 AW394

Home-Built Coil Three (SG, D, Trans)	AW404
Fan and Family Three (D, Trans, Class B)	25.11.33 AW410
£5 5s. S.G.3 (SG, D, Trans)	2.12.33 AW412

1934 Ether Searcher: Baseboard Model (SG, D, Pen)	20.1.34 AW417
1934 Ether Searcher: Chassis Model (SG, D, Pen)	AW419
Lucerne Ranger (SG, D, Trans)	AW422

Coscor Melody Maker with Lucerne Coils	AW423
Mullard Master Three with Lucerne Coils	AW424

£5 5s. Three: De Luxe Version (SG, D, Trans)	10.5.34 AW435
Lucerne Straight Three (D, RC, Trans)	AW437
All Britain Three (HF Pen, D, Pen)	AW448

"Wireless League" Three (HF Pen, D, Pen)	3.11.34 AW451
Transportable Three (SG, D, Pen)	WM271
£6 Gs. Radiogram (D, RC, Trans)	WM318

Simple-tune Three (SG, D, Pen)	June '33 WM327
Economy-pentode Three (SG, D, Pen)	Oct. '33 WM337

"W.M." 1934 Standard Three (SG, D, Pen)	WM351
£3 3s. Three (SG, D, Trans)	Mar. '34 WM354

Iron-core Band-pass Three (SG, D, QP 21)	June '34 WM362
1935 £6 6s. Battery Three (SG, D, Pen)	WM371
PTP Three (Pen, D, Pen)	June '35 WM389

Certainly Three (SG, D, Pen)	Sept. '35 WM393
Minutube Three (SG, D, Trans)	Oct. '35 WM396
All-wave Winning Three (SG, D, Pen)	Dec. '35 WM400

Four-valve : Blueprints, 1s. 6d. each.	
65/- Four (SG, D, RC, Trans)	AW370
"A.W." Ideal Four (2 SG, D, Pen)	AW402

2 H.F. Four (2 SG, D, Pen)	AW421
Crusaders' A.V.C. 4 (2 HF, D, QP 21)	18.8.34 AW445

(Pentode and Class-B Outputs for above: Blueprints, 6d. each):	25.8.34 AW445A
Self-contained Four (SG, D, LF, Class B)	Aug. '33 WM331

Lucerne Straight Four (SG, D, LF, Trans)	WM350
£5 5s. Battery Four (HF, D, 2 LF)	Feb. '35 WM381

The H.K. Four (HF Pen, HF Pen, D, Pen)	Mar. '35 WM384
The Auto Straight Four (HF Pen, HF Pen, DDT, Pen)	April '36 WM404

Five-valve : Blueprints, 1s. 6d. each.	
Super-quality Five (2 HF, D, RC, Trans)	May '33 WM320
Class-B Quadradyno (2 SG, D, LF, Class B)	Dec. '33 WM344

Mains Operated.

Two-valve : Blueprints, 1s. each.	
Consoelectric Two (D, Pen) A.C.	23.9.33 AW403
Economy A.C. Two (D, Trans) A.C.	WM286
Unicorn A.C./D.C. Two (D, Pen)	Sept. '35 WM394

Three-valve : Blueprints, 1s. each.	
Home-lover's New All-electric Three (SG, D, Trans) A.C.	AW383

These blueprints are full size. Copies of appropriate issues containing descriptions of these sets can in most cases be obtained as follows:—"Practical Wireless" at 4d., "Amateur Wireless" at 4d., "Practical Mechanics" at 7d., and "Wireless Magazine" at 1/3d., post paid. Index letters "P.W." refer to "Practical Wireless" sets, "P.M." to "Practical Mechanics" sets, "A.W." refer to "Amateur Wireless" sets, and "W.M." to "Wireless Magazine" sets. Send (preferably) a postal order (stamps over sixpence unacceptable) to "Practical and Amateur Wireless" Blueprint Dept., Geo. Newnes, Ltd., 8-11, Southampton Street, Strand, W.C.2.

Three-valve : Blueprints, 1s. each (contd.).	
S.G. Three (SG, D, Pen) A.C.	AW390
A.C. Triodyne (SG, D, Pen) A.C.	19.8.33 AW399
A.C. Pentaquester (HF Pen, D, Pen) A.C.	23.6.34 AW436

Mantovani A.C. Three (HF, Pen, D, Pen) A.C.	WM374
£15 15s. 1936 A.C. Radiogram (HF, D, Pen)	Jan. '36 WM401

Four-valve : Blueprints, 1s. 6d. each.	
All Metal Four (2 SG, D, Pen)	July '33 WM326
Harris Jubilee Radiogram (HF Pen, D, LF, P)	May '35 WM386

SUPERHETS.	
Battery Sets : Blueprints, 1s. 6d. each.	
Modern Super Senior	WM375
Varsity Four	Oct. '35 WM395

The Request All-Waver	June '36 WM407
1935 Super Tive Battery (Superhet)	WM379

Mains Sets : Blueprints, 1s. 6d. each.	
1934 A.C. Century Super A.C.	AW425
Heptode Super Three A.C.	May '34 WM350
"W.M." Radiogram Super A.C.	WM366
1935 A.C. Stenode	Apl. '35 WM385

PORTABLES.	
Four-valve : Blueprints, 1s. 6d. each.	
Midget Class B Portable (SG, D, LF, Class B)	20.5.33 AW389
Holiday Portable (SG, D, LF, Class B)	1.7.33 AW393

Family Portable (HF, D, RC, Trans)	22.9.34 AW447
TWO H.F. Portable (2 SG, D, QP21)	June '34 WM363
Tyers Portable (SG, D, Trans)	WM367

Five-valve : Blueprint, 1s. 6d.	
New Class-B Five (2 SG, D, LF, Class B)	Nov. '33 WM340

SHORT-WAVE SETS—Battery Operated.	
One-valve : Blueprints, 1s. each.	
S.W. One-valve converter (Price 6d.)	AW329
S.W. One-valve for America	AW429
Roma Short-waver	AW452

Two-valve : Blueprints, 1s. each.	
Ultra-short Battery Two (SG det, Pen)	Feb. '36 WM402
Home-made Coil Two (D, Pen)	AW440

Three-valve : Blueprints, 1s. each.	
World-ranger Short-wave 3 (D, RC, Trans)	AW355
Experimenter's 5-metre Set (D, Trans, Super-regen)	30.6.34 AW438

Experimenter's Short-waver (SG, D, Pen)	Jan. 10, '35 AW463
The Carrier Short-waver (SG, D, P)	July '35 WM390

Four-valve : Blueprints, 1s. 6d. each.	
A.W. Short-wave World Beater (HF Pen, D, RC, Trans)	AW436
Empire Short-waver (SG, D, RC, Trans)	WM313
Standard Four-valve Short-waver (SG, D, LF, P)	Mar. '35 WM338

Superhet : Blueprint, 1s. 6d.	
Simplified Short-wave Super	Nov. '35 WM397

Mains Operated.	
Two-valve : Blueprints, 1s. each.	
Two-valve Mains short-waver (D, Pen) A.C.	AW453
"W.M." Band-spread Short-waver (D, Pen) A.C./D.C.	WM368
"W.M." Long-wave Converter	WM390

Three-valve : Blueprint, 1s.	
Emigrator (SG, D, Pen) A.C.	WM352

Four-valve : Blueprint, 1s. 6d.	
Standard Four-valve A.C. Short-waver (SG, D, RC, Trans)	Aug. '35 WM391

MISCELLANEOUS.	
Enthusiast's Power Amplifier (1/6)	June '35 WM38
Listener's 5-watt A.C. Amplifier (1/6)	Sept. '35 WM392
Radio Unit (2v.) for WM392 (1s.)	Nov. '35 WM398
Harris Electrogram (battery amplifier) (1/-)	Dec. '35 WM399
De-Luxe Concert A.C. Electrogram	Mar. '36 WM403
New style Short-waver Adapter (1s.)	June '35 WM388
Trickle Charger (6d.)	Jan. 5, '35 AW426
Short-wave Adapter (1s.)	Dec. 1, '34 AW456
Superhet Converter (1s.)	Dec. 1, '34 AW457
B.L.D. L.C. Short-Wave Converter (1s.)	May '36 WM405
Wilson Tone Master (1s.)	June '36 WM406
The W.M. A.C. Short-Wave Converter (1s.)	July '36 WM408

Miscellaneous Advertisements

Advertisements are accepted for these columns at the rate of 3d. per word. Words in black face and/or capitals are charged double this rate (minimum charge 3/- per paragraph). Display lines are charged at 6/- per line. All advertisements must be prepaid. All communications should be addressed to the Advertisement Manager, "Practical and Amateur Wireless", 8, Southampton Street, Strand, London.

RECEIVERS, COMPONENTS AND ACCESSORIES

Surplus, Clearance or Secondhand, etc.

RADIOMART
SHORT-WAVE SPECIALISTS

Announce 1937

SHORT-WAVE MANUAL

Packed with short-wave information and circuits of mains and battery receivers, including straight, superhet and 5-metre transmitters, modulators, etc. Information on transmitting licences, aeriols, Class B amplification, neutralization, superhet alignment, etc. The most comprehensive manual published, written by practical engineers, price 6d., post free 7½d., including catalogue.

1937 Catalogue only (3 times enlarged) price 1½d. post free.

TELSEN screened dual range coils, 2/6. Pair 4/6. Milliammeters, 25ma. upwards, 5/9. Super, 6/9. AMERICAN mains transformers 230 v. fully shrouded, 350/350. 6.3v., 5v., 6/11. Majestic 250/250. 2.5v., 5v., 4/11.

HEAVY DUTY mains transformer worth 35/-, 350/350. 150 ma. 4 v. 2.5ACT, 4v6ACT, 12/6. KC/S. IF transformers, 2/11. Telsen Ace, 1/11. RG4, Radiograms, 2/9. 2mf. 300v./9d.

UTILITY straight line wavelength dials, 3/11. Telsen H.F. chokes, 1/11. UTILITY 2-gang unknob and dial, 3/11; 1,500-volt tubular condensers, all sizes, 6d.

ELECTROLYTICS 500-volt 8mf. 1/8; 4mf. 1/6; 4 x 4 1/11; 8 x 8 3/6; 25mf. 25v. 1/-, etc.

SMOOTHING chokes, 20 hy, 120 m.a., 3/11; 100 m.a., 2/11; 40 m.a., 1/11. PUSHBACK wire, 6 yds. 6d.; heavy 9d.; 2 gross solder tags, 6d.; resin-cored solder, 9ft. 6d.

CENTRALAB pots, all sizes, 1/8; switched, 2/-; tubular glass fuses, 2d. JENSON PM speakers; 12/6. Varley Iron core coils, 2/6; matched pair, 4/6.

SPECIAL OFFER Class B valve, driver transformer and valveholder, new, lot 5/-.

LISSEN 3-gang bandpass, 3-gang superhet, 2-gang allwave coils, any set, price 7/6. TRADERS' monster bargain parcels, value £4/10/-, for 10/-; also 5/- parcels.

FAMOUS Continental A.C. valves, 4/6; American Duotron, etc., all types, 3/6; battery from 2/3. UTILITY 8/6, microdisc dials, 3/11; Radiophone, 0.00016 short-wave condensers, 3/6; series gap, twin, 3/9.

CERAMIC all brass microvariables, 15 mmf., 1/4; 40 mmf. 1/7; 100 mmf., 1/10; short wave H.F.C., 9d. CLEARANCE catalogue 1½d. Goods over 5/- post free. All enquirers must send stamp.

Branches: 19, John Bright St., 44, Dale End. Mall Orders, 44, Holloway Head, Birmingham. Telephone, MID 3254.

WE BUY for cash, all types of Modern Second-hand Radio Sets, Accessories, etc. Unbeatable Part-exchange allowances for new goods. Bring, send or write.

UNIVERSITY RADIO LTD., 82, Hampstead Road, London, N.W.1. Phone: Euston 3810.

CONVERSION UNITS for operating D.C. Receivers from A.C. Mains, improved type, 120 watts output, at £2/10/0. Send for our comprehensive list of speakers, Resistances and other components.

WARD, 46, Farringdon Street, London, E.C.4. Telephone: Holborn 9703.

ALL goods previously advertised are standard lines, still available. Post card for list free. **VAUXHALL UTILITIES**, 163a, Strand, W.C.2. Over Denny's the Booksellers, Temple Bar 9338.

ALCO ELIMINATORS AND CHARGERS.—3-5 H.T. taps, 120/150v., 20/30 m.a., 2/-; With ½ amp. charger, 26/-; with ½ amp. charger, 30/-; Charger alone, 12/- Year's guarantee. Details free.—P. and D. Radio, 1, Gooding Road, N.7.

PREMIER SUPPLY STORES

Offer the following Manufacturers' Brand New Surplus Goods at a Fraction of the Original Cost; all goods guaranteed perfect; carriage paid over 5/-; under 5/- postage 6d. extra. Orders under 5/- cannot be sent C.O.D.

1/9 SHORT-WAVE COILS, 4- and 6-pin types, 13-26, 22-47, 41-94, 78-170 metres, with circuit.

4/- SPECIAL set of 3 S.W. coils, 14-150 metres, with circuit.

2/- PREMIER 3-band S.W. Coil, 11-25, 19-43, 38-86 metres. Simplifies S.W. receiver construction, suitable any type circuit.

1/- COIL FORMERS, in finest plastic material, 1¼in. low-loss ribbed, 4- or 6-pin.

SUPER CERAMIC CONDENSERS, S.L.F. .00016, .0001, 2/9 each; double-spaced, .00005, .00025, .00015 3/- each. All brass with integral slow motion, .00015 tuning, 3/9; .00015 reaction, 2/9. British, Radiophone 2-gang .00016 with trimmers, 5/6.

4/6 MAINS VALVES, famous Europa 4 v. A.C. types, H.L., L., S.G., Var-Mu-S.G., H.F.-Pens. Var-Mu-H.F. Pens., 1, 3 and 4-watt A.C. directly heated output Pentodes. Full-wave rectifiers, 250 v. 60 m.a. A.C./D.C. types. 20-volt. .18 amp. S.G., Var-Mu-S.G., H., H.L., Power.

5/6 FOLLOWING TYPES. Full-wave rectifiers, 350 v. 120 m.a. and 500 v. 120 m.a. 2½ watt indirectly-heated Pentodes. Frequency Changers, Octodes and Heptodes.

BATTERY VALVES. 2 volts, H.F., L.F., 2/3. Power, Super-Power, 2/9. S.G. Var-Mu-S.G., 4- or 5-pin Pentodes, H.F. Pens, V-Mu-H.F. Pens, 5/- Class B., 3/6.

5/6 AMERICAN VALVES. Genuine American HYTRON first-grade Valves, 3 months' guarantee. All the following types: 1A6, 1C6, 2A3, 2A5, 2A6, 2A7, 2B7, 6A4, 6A7, 6B7, 6C6, 6D6, 6F7, 6OA, 6O1A, 11, 12, 15, 18, 19, 20, 22, 24A, 26, 27, 30, 31, 32, 33, 34, 35, 36, 37, 38, 39/44, 40, 41, 42, 43, 45, 46, 47, 48, 51, 53, 55, 56, 57, 58, 59, 71A, 75, 76, 77, 78, 79, 80, 81, 82, 83, 84, 85, 89, V99, X99, 112A, 1V0, 5Z3, 12Z3, 25Y5, 25Z5, 6A6, 6B5, 185R, 210 and 250, 8/6 each. New Metal-glass Valves, all types, 6/6 each. Genuine American DUOTRON Valves, all types, 3/6 each.

VALVE HOLDERS for all above types, 6d. each. Octal Bases, 9d. each.

12/6 SHORT-WAVE KIT for 1-valve receiver or adaptor, complete with chassis, 4 coils, 14-150 metres, condensers, circuit and all parts, VALVE GIVEN FREE! DE LUXE MODEL, 17/6. SUPERHET CONVERTER KIT, 13/6.

19/6 2-VALVE S.W. Kit. Valves given free!

42/- 3-VALVE S.W. Kit. S.G. Det. 2 Pen. Valves given free!

50/- ALL-WAVE "ALL-WORLD RANGE". 3-valve kit, 12-2,000 metres in 4 wavebands without coil changing, complete kit of parts with 3 valves, S.G.H.F., S.G. Det. and Pentode (2 volts), Q.P.P. Model, 6/6 extra.

12/6 LISSEN ALL-WAVE COILS, 12-2,000 metres, complete with switching and wiring diagram.

40/- 3-WATT A.C. AMPLIFIER, 2-stage for mike or pick-up, complete kit of parts with 3 valves.

SPECIAL OFFER! 12/6 P.M. Speaker, 35/- Transverse Current Mike, complete with transformer and 7/6 Stand. If purchased with above kit, 25/- the lot.

£4:4:0 7-WATT A.C./D.C. AMPLIFIER. 3-stage, high-gain, push-pull output. Complete kit of parts with 5 specially matched valves.

SPECIAL OFFER! 21/- pair Matched Speakers, 35/- Transverse Current Mike, complete with transformer and 7/6 stand. If purchased with above kit, 35/- the lot.

£5:5:0 10-WATT 3-stage A.C. Amplifier Kit with 5-valves.

SPECIAL OFFER! 21/- pair Matched Speakers, 35/- Transverse Current Mike, complete with transformer and 7/6 stand. If purchased with above kit, 35/- the lot.

£8:8:0 20-WATT 3-stage A.C. Amplifier Kit with 5 valves.

SPECIAL OFFER! £8 pair P.M. Exponential Horn Speakers, 35/- Transverse Current Mike with transformer and 7/6 stand. If purchased with above kit, £5 10s. the lot.

MAGNAVOX, Mains energised, '154', 7in. cone, 2,500 ohms 4 watts, 12/6; '152', 9in. cone, 2,500 ohms 17/6; '152 Magna', 9in. cone, 2,500 ohms, 6 watts, 37/6. Magnavox P.M.'s—'154', 7in. cone, 16/8; '252', 9in. cone, 22/6. Reliable P.M.'s, 10/6; Cosor P.M.'s, 13/6.

ROLA latest type P.M.'s, 18/6. K.B 7in. mains energised, 1,500 or 2,500 ohms, 7/9. GOODMAN'S 8in. mains energised, 1,000 ohms field, 10/6 each.

ALL POST ORDERS TO JUBILEE WORKS, 167, LOWER CLAPTON RD., LONDON, E.5 CALLERS, AS USUAL, TO 20-22, HIGH ST., CLAPHAM, S.W.4. (Macaulay 2381) 'Phone: Amherst 4723. And 165 & 165a FLEET ST., E.C.4. (Next door to Anderton's Hotel). Central 2833.

DIALS.—Clarion Illuminated S.W. slow-motion Dial with 2in. knob, 2/- Premier All-Wave 2-speed Dial, full vision straight-line, dual ratios 10-1 and 150-1, 6/6, with escutcheon.

POTENTIOMETERS by well-known makers. All values up to 1 meg., 2/-; with switch, 2/6.

30/- PREMIER (Reisz Pattern) Transverse-current MIKE, High Output, Straight Line Response. Transformers, 5/-. Table Stand, 7/6.

PREMIER wire-end type with screened primaries, and tapped 200-250 v. Centre-tapped Filaments. Guaranteed one year. H.T. 8 & 9 or H.T. 10 with 4 v. 4 a. C.T. and 4 v. 1 a. C.T., 8/6. 250-250 v. 60 m.a., 4 v. 1 a., 4 v. 2 a. and 4v. 4 a., all C.T., 8/6. 350-350 v. 120 m.a., 4 v. 1 a., 4 v. 2 a. and 4 v. 4 a., all C.T., 10/6. Any of these transformers with engraved panel and N.P. terminals, 1/6 extra. 500-500 v. 150 m.a., 4 v. 2-3 a., 4 v. 2-3 a., 4 v. 2-3 a., 4 v. 3-4 a., all C.T., 10/6. AUTO TRANSFORMERS, step up or down, 60 watts, 7/6; 100 watts, 10/-.

SMOOTHING CHOKES, 25 m.a., 2/9; 40 m.a., 4/-; 60 m.a., 5/8; 150 m.a., 10/6. 2,500 ohms, 60 m.a. Speaker Replacement Chokes, 5/6.

5/9 MILLIAMMETERS, moving-iron, flush, 2¼in., all ranges from 0-10. Visual tuning, 6 or 12 m.a., 5/9; Moving-coil meters, 2¼in. 0-1 m.a., 18/6; 3¼in. 0-1 m.a., 22/6. Multipliers, 1/- each.

ELECTROLYTICS. U.S.A. 4, 8, or 12 mfd. 530 v. peak, 1/9 each. Dubilier, 4 or 8 mfd. 500 v., 3/-; 50 mfd. 50 v., 1/9; 12 mfd. 20 v. 6d., 25 mfd. 25 v. 1/-, T.C.C. 4 or 8 mfd. 650 v., 4/-; 15 mfd. 50 or 100 v., 1/-; 50 mfd. 12 v., 1/- Paper Condensers. W. K., 250 v. working 4 mf., 2/-; 2 mf. 1/-, 1 mf. 6d.; 350 v. working 4 mf., 2/6; 2mf., 1/6; Dubilier 500 v. working 4 mf. 4/-; 800 v. 4 mf. 6/- Wego 450 v. working 1 mf. 1/-, 2 mf. 1/9, 4 mf. 3/- 700 v. working 2 mf. 2/-, 4 mf. 3/6.

TRANSFORMERS, latest type Telsen R.G.4 (list 12/6), 2/9. Lissen Hypernik Q.P.P. (list 12/6), 3/6.

10/- ELIMINATOR KITS for A.C. mains, 120 v., 20 m.a., or 150v. 25 m.a., tapped S.G. det. and output. Complete Kit with long life valve rectifier (replacement cost only 2/-).

PREMIER L.T. CHARGER KITS for A.C. mains, including Westinghouse Rectifiers and Tapped Mains Transformers. 8 volts at 1 amp, 14/6; 8 volts 1 a., 17/6; 15 volts 1 a., 19/-; 15-15 volts 1 a., 37/6; 15+15+15 volts 1 a., 50/-; 8 volts 2 a., 29/6.

TELSEN Iron core screened coils, W.349, 4/- each. Electric SOLDERING IRONS, 200-250 v., A.C./D.C., 2/3.

GRAMOPHONE MOTORS, Collaro Gramophone Unit consisting of A.C. motor, 100-250 v. high quality pick-up and volume control, 45/-; Collaro motor only, 30/-; Collaro Universal Gramophone Motor, 100-250 v. A.C./D.C. with high quality pick-up and volume control, 67/6; Collaro Universal Motor only, 49/6; Edison Bell double-spring motors, including turntable and all fittings, 15/-; Cosmocord Gramo unit, comprising A.C. motor pick-up and volume control (list 55/-), 35/9.

COSMOCORD Pick-Up with Tonearm and Vol. Control, 10/6. Pick-up head only, 4/6.

6d. TUBULAR CONDENSERS, non-inductive, all values up to .5 mfd.

WIRE-END RESISTORS, any value, 1 watt, 6d.; 4 watts, 1/-; 8 watts, 1/6; 15 watts, 2/-; 25 watts, 2/6 each.

2/- RELIABLE MORSE KEYS with Morse Code engraved on bakelite base.

BAKELITE case BUZZERS, 1/6; "Loud-tone," 2/6 each.

3/9 SUPER QUALITY lightweight HEADPHONES, pair.

69/6 RECEIVERS, G.E.C., A.C./D.C. (mains, 3-valve sets, complete [with 3 Osram valves, in exquisite bakelite cabinet with Osram M.C. speaker, ready to plug in to any mains, brand new, in sealed cartons, fully guaranteed (list £7 15s.), Carriage paid.

50/- G.E.C. Compact 3-valve Battery Sets complete with 3 Osram valves, moving coil P.M. Speaker in attractive Bakelite cabinet, makers' 1936 series in original sealed carton (list £5/10/0).

H.F. CHOKES, S.W. 10-200 metres, 9d.; S.W. screened, 1/6; standard screened 180-2,000 metres, 1/6.

HAVE YOU HAD OUR LATEST GIANT ILLUSTRATED CATALOGUE AND VALVE LIST? IF NOT SEND 4d. IN STAMPS FOR THIS AMAZING LIST OF BARGAINS!

RADIO CLEARANCE

63, HIGH HOLBORN, W.C.1.

TEL.: HOLBORN 4631.

The Mail Order House with the World-Wide Reputation. Quality goods and satisfaction assured.

EXCLUSIVE BRITISH RIGHTS HELD BY US FOR CONSTRUCTRAD SHORT-WAVE KITS. All kits supplied valves free. Five interchangeable coils covering a range from 15-600 metres. Complete set, not a converter.

29/6 ONE-VALVE BATTERY KIT.

37/6 TWO-VALVE BATTERY KIT.

37/6 ONE-VALVE A.C./D.C. KIT.

£5.19.6 EVER READY 5-VALVE BATTERY S.H. Incorporating A.V.C., large square-type dial, provision for pick-up and extension speaker. Listed 12 gns. Stocks are limited, order at once to avoid disappointment.

57/6 LISSAN BATTERY BAND PASS 3. Complete with valves. Screen grid, detector, pentode. **LISSAN 4-VALVE A.C. BAND PASS RECEIVER.** A quality job, listed at £0 15s. Sent out aerial tested, complete with valves.

35/- LISSAN 3-VALVE PLUS BARRETTA D.C. RECEIVER. Fitted handsome horizontal Walnut Cabinet. Complete with valves.

75/- A.C./D.C. AMERICAN MIDGET, 5-valve type. A real quality job. Jensen M.C. Speaker, etc. Brand new, boxed.

BRUCE MAINS TRANSFORMERS AND CHOKES, standard for the season, finest made, British and guaranteed.

8/6 250-0-250, 80 m.a., 2-0-2 volts, 2.5 amp., 2-0-2 volts, 4 amp.

10/6 350-0-350, 120 m.a., 2-0-2 volts, 2.5 amp., 2-0-2 volts, 4 amp.

12/6 350-0-350, 150 m.a., 2-0-2 volts, 2.5 amp., 2-0-2 volts, 4 amp., 2-0-2 volts, 2 amp.

17/6 500-0-500, 150 m.a., 2-0-2 volts, 2.5 amp., 2-0-2 volts, 6 amp., 2-0-2 volts, 2 amp., 2-0-2 volts, 2 amp.

8/6 H.T.8 TRANSFORMER. 250 volts, 60 m.a., 2-0-2 volts, 4 amp.

17/6 Ditto with H.T.8 metal rectifier.

ALL TRANSFORMERS ARE FULLY SHROUDED. MAINS CHOKES,

4/6 40 m.a. 30 henrys.

6/- 60 m.a. 40 henrys.

10/6 150 m.a. 40 henrys.

21/- 250 m.a. 15 henrys.

6/- 60 m.a. 80 henrys. 2,500 ohms for speaker replacement, etc.

12/6 SPECIAL CLEARANCE CHOKE, 250 m.a. 12 henrys, 100 ohms heavy duty type, interleaved windings, etc. Cannot be repeated.

TRIAD AMERICAN VALVES, highest quality. All types 5/6 each as follows:

01A, 24A, 27, 30, 31, 32, 33, 35, 37, 38, 39, 41, 43, 45, 46, 47, 53, 55, 56, 57, 58, 59, 71A, 75, 78, 80, 6A6, 1C6, 6E7, 2A3, 5Z3, 12A7, 6A7, 6C6, 6D6, 12Z3, 25Z5.

All these valves carry a 90-day guarantee and free replacement provided that the filament or heater is intact and the glass not broken when returned to us.

3/6 LISSAN CLASS B VALVES brand new, boxed.

2/6 8 mfd. and 4 mfd. ELECTROLYTICS, 450 volt working, 500 volt peak.

6d. 1 watt WIRE END RESISTANCES, well-known make, all values.

3/6 8 plus 8 cardboard, wire ends, ELECTROLYTICS, 450 volt working, 500 surge. Well-known manufacture.

1/- 50 mfd. 12 volt working CONDENSERS. Well-known manufacture.

1/6 50 mfd. 50 volt working CONDENSERS. Well-known manufacture.

1/3 50 mfd. 25 volt working CONDENSERS. Well-known manufacture.

1/- 25 mfd. 50 volt working CONDENSERS. Well-known manufacture.

3/11 8 plus 8 plus 4 ELECTROLYTIC CARD-BOARD CONDENSERS, wire ends. 450 volt working.

2/6 14 plus 8, 450 volt working ELECTROLYTIC CONDENSERS. Metal case, wire ends, by well-known manufacture.

1/- 25 volt 25 mfd. ELECTROLYTIC CONDENSERS, Tubular type, by well-known manufacture.

12/6 P.M. MOVING-COIL SPEAKER, 7 1/2 in. CONE, by well-known manufacture.

9/6 P.M. MOVING-COIL SPEAKER, 6 in. CONE, by well-known manufacture.

3/6 MULTI-PURPOSE VALVE, suitable for H.F. Pentode. List 21s.

6d. TUBULAR CONDENSERS, wire end type, all sizes up to 0.1.

1/6 LISSAN CENTRE TAPPED CHOKES. Brand new, boxed.

1/- LISSAN INTER-VALVE CHOKES. Brand new, boxed.

(Continued at top of column three)

"QUALITY"



Special 6-VALVE BAND-PASS SUPERHETERODYNE

Price complete with B.V.A. Valves £6:10.

Specially designed and built for high quality radio/gram work. **SPECIAL FEATURES:** Reinforced stout steel chassis. High class components by well-known makers of acknowledged reputation used throughout. Fitted with attractive and specially large full-vision dial, glass fronted, and supplied complete with escutcheon and fittings. Separate illumination automatically switched in for radio/gramophone.

CIRCUIT DETAILS: Inductively coupled band-pass filter, triode-hexode frequency changer, band-pass I.F.T. coupled I.F. amplifier, I.F.T. coupled to diode detector. D.A.V.C. applied to preceding valves. I.F. amplifier capacity-coupled to output pentode 3-53 valve undistorted. Variable tone control and volume control operate on both radio and gramophone. Alternative triode output PX4 or AC044 10s. extra.

All receivers supplied complete with valves, knobs, pilot lamps, leads, mains cable and plug. 12 months' guarantee. Deferred terms on application to London Radio Supply Co., 11, Oat Lane, E.C.2.

MCCARTHY RADIO LTD.

44a, Westbourne Grove, Bayswater, W.2

Telephone: Bayswater 3201/2

ELECTRADIX BARGAINS

A BARGAIN IN DYNAMOS. Type "C." Our latest for Bungalow, Yacht or Child Charging. 140 watt. Enclosed Dynamo, 19-20 v. 19 amp. Bull Bearings, Vee Pulley, 25s.

Marine Type Switchboard with Ammeter, maximum and minimum Auto Cutout Malus Switch and Fuses, Field Regulator, 25/-, or 47/6 the pair (as illustrated).

DOUBLE CURRENT DYNAMOS. D.C. 600 volts, 100 m.a., and 6 volts 3 amps., 32/6.

ROTARY CONVERTER, supply A.C. sets on D.C. Malus, 12 v. Battery or Ship Wiring. With filter. All in silence cabinet. Larger machines, 1 kw., 1 kw., and 1 1/2 kw., cheap. T.V.T. Vibratory Units, 4 v. D.C. to 250 v. 47/6 (as illus.). A.C. 12 m.a., 27/6.

M.G. in Silence Cab. With Filter D.O.-D.C. 6 v. to 180 v. 25 m.a., 65/-. Westinghouse RCG1, 222. Davenport MGC3, £8/10.

CHARGERS, H.T. and L.T., off A.C. Metal cased, Transf. and Rectifier, 2, 4, and 5 volts, 800 m.a., 60, 90 and 120 volts 100 m.a., complete, 37/6. Larger, 6 volts, 2 amps., all in steel case, 57/6. Others in stock up to 80 cells.

MAGNETIC AUTO SWITCHES. -Minimum 10/-, Max. overload Trip, 2 and 4 amps., 7/6. 6 amps., 10/-, 10 amps., 12/-, 15 amps., 14/-, Contractors for remote control, 6 amps., 10/-, 15 amps., 12/6. Keying Relays, 15/-.

SHORT WAVE 2 pin short wave coils 3, 4, 5 & 6 turns, 1/-, Steatite lead in with brass stem, 8d. 3" stand-off insul. 6d.

HEADPHONES. Ericsson and others, 2,000 ohms, 4/8. 120 ohms, 2/9. Single High res. earpieces, 2/8. Wall or Table Mouthphones, 25/-.

CHEAP MORSE LEARNING SETS, with Battery and Buzzer, 4/8.

METERS.—DIX-ONEMETER, 50-range microamps., mmps., milli-volts and volts, ohms and meg., all in one Precision moving coil Meter with multipliers. Accurate and marvellously cheap, 55/-. Multipliers extra. Worth £10. The "Dix-Mipanta" is an A.O.-D.C. mains-vest-pocket, bakelite Voltmeter. List 22. Trade 19/6.

Micro-Ammeter 2 1/2" panel 0-50 ma., 40/-. 3,000 Switchboard Service and panel Meters in stock, lowest prices. Meters, all ranges, 50 microamps., 40/-, Weston Table Meters, 18/6. Charging Pole Testers, 2/8. 0-20 volts, 5/-, 0-50 volts, 5/-, 0-100 volts, 5/6. 0-200 volts, 6/-, All A.O. or D.C. Repairs to all types.

MEGERS as new. Direct Reading, 001 ohms to 10 meg. Long scale dial for Resistance makers. 100, 250 and 500 volts, cheap.

SILVERTOWN Portable Tester. Combines Wheatstone Bridge Galvo, shunts and ratios, as new, £8. G.P.O. Plug-in Bridge Resistance Boxes, to 8,000 ohms, 90/-.

COMMUTATORS. For Motors and Dynamos 5 to 500 volts. 2/- each.

H.T. TRANSFORMERS.—200-240 to 10,000 v. 25 m.a., 34/-; 5,000 volts 20 m.a., 19/6; 2,500 v. 15 m.a., 17/6. Large "Butter fly" Neon Signs, 4ft. 2in. x 4ft. 11in. x 6in., on glass panel, ready-for use, £7.

COMPASSES. Boat Binnacle Mariners' 6in. Boat Compass, floating, gimbal glass case, 35/-; Magnetic Compass, 1 1/2in. Brass Case, bevel glass, plain dial, unsealed, new, 9d. War Office Prismatic, 25/-; Travellers' pocket, 15/-.

Send for Electrical and Radio Lists "N."

ELECTRADIX RADIOS

218, UPPER THAMES ST., LONDON, E.C.4.

Phone: Central 4611.

(Continued from foot of column one)

5/- MIDGET 2-GANG .0005 CONDENSERS, fully screened, top trimmers, by well-known manufacture. Hours of Business, 9 a.m. to 7 p.m. Saturdays, 9 a.m. to 1 p.m. All orders value 5s. and over Post Free. Orders under 5s. must be accompanied by a reasonable amount for postage. Enquiries, 11d. stamp if reply expected.

RADIO CLEARANCE

63, HIGH HOLBORN, W.C.1.

TEL.: HOLBORN 4631.

RECEIVERS, COMPONENTS AND ACCESSORIES

Surplus, Clearance or Secondhand, etc.

SOUTHERN RADIO'S Wireless Bargains; all goods guaranteed and sent post paid.

RECEIVERS.—G.E.C. A.C./D.C. mains 3-valve sets, complete with 3 Osram valves, in exquisite bakelite cabinet, Osram M.C. speaker, ready to plug in to any mains, brand new, in sealed cartons, fully guaranteed; £3/5 each (list £7/15).

G.E.C. 3-valve Battery Sets, "Battery Compact Three," with 3 Osram valves, moving coil speaker in beautiful bakelite cabinet, brand new, in sealed cartons, fully guaranteed; 50/- each (list £5/10).

MULLARD M.B.3 Battery Sets, complete with 3 Mullard valves (3 pentodes), moving coil speaker, Excide batteries and accumulator, contained in handsome walnut cabinet, brand new, in sealed cartons; £4/10 each (list £8/8).

SPEAKERS.—Celestion Soundex permanent magnet, S 10/-; Telsen permanent magnet, with 10-ratio transformer to suit any receiver, 12/6; Telsen loud speaker units, 2/6; all brand new and in sealed cartons.

COILS.—Telsen, iron core, W349, Midget size, 4/-; Type W478 (twin), 9/- pair; W477 (triple), 16/- set; Type W476 (triple superhet selector and oscillator), 16/- set, all ganged coils complete on base with switch; Telsen I.F. transformer coils, W482, 5/-; Telsen dual range aerial coils, with aerial series condenser incorporated; W76, 4/-; Telsen aerial series condensers with shorting switch, 2/-; Telsen L.F. transformers Type R.G.4 (4 to 1), 3/-; all brand new, in sealed cartons.

MICROPHONES.—Ace (P.O.) microphones, complete with transformer, ready for use with any receiver, 4/8 each; Ace concert microphone, complete on chromium stand with volume control, ready for use with any receiver and amplifier, 11/-.

RESISTANCES.—Tru-ohm 1-watt, colour coded and marked, 36 assorted capacities on card; 6/- per card.

POTENTIAL Dividers.—Lissen wire wound, 3-section, 60-watt, 4,500 ohms, 3,000 ohms, and 2,000 ohms; 3-section, 5 watts, 20,000, 20,000, and 20,000 ohms; 2-section, 5 watt, 50,000 and 30,000 ohms; 1-section, 5 watt, 8,000 ohms, all at 1/3 each; brand new and guaranteed.

AMERICAN VALVES.—A full range of valves for all American receivers; 6/- each.

HEADPHONES.—Lightweight headphones, double pole type, 4,000 ohms each ear piece; 3/- pair.

REPAIRS.—Any type of receivers, American, British, etc., repaired by expert staff.

IMPORTANT Announcement.

WE Have Purchased the Complete Component Stock of a Well-known Radio Dealer and Manufacturer, and we are offering the complete stock in parcel lots as under:

5/- Parcel, containing components to the value of at least 20/-, comprising chokes, resistances, coils, switches, condensers, wire and circuits, 5/- per parcel.

10/- Parcel, containing components to value of at least 45/-, comprising variable condensers, screened chokes, switches, resistances, screened coils, wire, circuits, etc., etc.; 10/- per parcel.

ALL Articles Included in these Parcels are Brand New and Modern.

SOUTHERN RADIO.—Branches at 271-275, High Rd., Willesden Green, N.W.10; 46, Lisle St., London, W.C.2. All mail orders to 323, Euston Rd., London, N.W.1.

SOUTHERN RADIO, 323, Euston Rd., London, N.W.1 (near Warren Street Tube). Phone: Euston 3775.

VALVES

VALVES. By well-known manufacturer. Complete range of Battery, A.C. Mains, Rectifiers. Brand new stock with six months' guarantee. 2 volt Detector, 2/3, Power, 2/9, Screen Grid, Pentode, H.F. Pentode 5/-, etc. The following American type valves, fully guaranteed, at 5/6 each: No. 80, 42, 43, 57, 58, 77, 78, 6C6, 6D6, 25Y5, 25Z5. Write for other prices to: Dulci Electrical Co., Ltd., 7, Lizard Street, London, E.C.1.

SHORT WAVES

SHORT WAVE on a crystal set. Full building instruction and crystal, 1/2 post paid.—Radiomail, Tanworth-in-Arden, Warwickshire.

LOUDSPEAKER REPAIRS

REPAIRS to Moving Coil Speakers, Cones and Coils fitted or rewound. Fields altered. Prices Quoted including Eliminators, Loud-speakers Re- paired, 4/- L.F. and Speech Transformers, 4/- post free. Trade invited. Guaranteed. Satisfaction. Prompt Service. Estimates Free. L. S. Repair Service, 5, Balham Grove, London S.W.12 Battersea 1321.

NEW RECEIVERS, COMPONENTS, AND ACCESSORIES

HULBERT for Quality Surplus Speakers. All Music Lovers should write for List of amazing bargains. Prices from 8/6 brand new. Made by best known British maker.—Hulbert, 6 Conduit Street, W.1.

BANKRUPT Bargains. List free. All new goods. Let me know what type of set you require and get my price first. Mullard MU35 6v. superhets and M3A battery sets. Truphonic battery and mains superhets. Pilot and Ferguson all-wave superhets. Lotus 4v. Midget A/DC portables, 65/-. Cossor. DC 8G 3v. 75/-. Burgoyne 4v. Fury radiogram, £8/10. Ecco 12v. car radio, £7. Ferguson ditto 6v £8. Large stockspeakers—Celestion, Ormond, Rola, etc. Replacement valves for most types. Large stock components.—Butlin, 6, Stanford Avenue, Brighton, Sx. Preston 4030.

RADIO AND ENGINEERING SUPPLIES.

TUBULAR Condensers, by well-known manufacturer, .002, .01, .05, .02, 3d. : 1, 25, 5d.
ERIE Resistors, 1-watt, all values, 4d.
SHORTWAVE Plug-in coils, lit standard valve-holder, 13-20, 22-47, 41-94 metres, 4- or 6-pin, 1/9d. each. Super Quality, 2/6d. each, set of three, 7/-.
SHORTWAVE Condensers .0001, .00015, .0002, .00025, 1/11d. With 10-1 slow-motion and 3in. dial and knob, 2/11d.
SHORTWAVE all brass, slow-motion condensers, .0001, .00015, 4/3d.; .0002, .00025, 4/9d.
SHORTWAVE Low-loss chokes, 10-100 metres, 7d. each.
SHORTWAVE Straight vision drive, 4/9d.; dual ratio, 8-1 and 100-1, 5/6d.
VALVE Holders Clix Chassis mounting, 4- and 5-pin, 3d.; 7-pin, 4d.
AMERICAN Valves, first grade Hytron, three months' guarantee, all types, 5/-. Line cords, 2/6d. each.
SHORTWAVE Bargain lists now available, send stamp.
ELIMINATORS, Speakers, kits, etc., write for lists.
HIVAC Valves, complete stock, send for list, liberal discount to the trade.
TRAD E Enclosures, send stamp and trade heading for latest lists.
RADIO AND ENGINEERING SUPPLIES, 88, Edgware Rd., London W.2. Phone: Paddington 6652.

RADIO BARGAINS

AMAZING Prices. New and Shop-soiled Mains and Battery Sets, Components, American, English Valve replacements. All-Wave Superhets. Listed at £11/11-. My price £8/18/6. All-Wave Radio Gram, Chassis Valves and Speaker listed at £8/10/-. My Price £6/12/6. Lotus Midget AC/DC MC Speakers, 65/-. Stamp for list.—LITTLER, 2 Barras Lane COVENTRY.

MISCELLANEOUS

WESTERN ELECTRIC Microphones, 1/6 each, post free; 2 Transformers to match, 1/3; 500 clearance lines, catalogues 3d. each.—J. Bearfield, 105, Upper Street, London, N.1.

HEADPHONES. Brown, G.E.C., B.T.H., Nesper, Sterling, Ericsson, Marconiphone, Telefunken, etc., from 2/6 pair. Postage 6d. List free. **CRYSTAL SETS.** Complete. Guaranteed. Burne-Jones, 5/6. Ditto, double circuit, 8/-. Large P.O. type, 10/-. Crystal detector. Complete parts, 1/-. Sensitive permanent detector, 1/6.—Post Radio, 183, Caledonian Road, London, N.1.

RESISTANCES.—1 watt metallised. One dozen good sizes, 1/3. 2 mfd.'s 1,000 v. Helsby, 3 for 1/9. Postage 4d.—Fleming, 115, Ridley Road, E.8.

CORRESPONDENTS PRAISE New Theory Book. 1s. D'Arcy Ford, 15, Gandy Street, Exeter.

EXPERIMENTER'S OPPORTUNITY. Parcels containing Wireless Components 40/- value for 5/6. Carriage 1/-.—Taylors', Radio House, Maraulay Street, Huddersfield.

WE WILL MAKE A GENEROUS ALLOWANCE on your old set or components in part exchange for any new receiver or Peto-Scott kit. Write for **FREE EXPERT ADVICE** before making your final choice. You are then assured of **COMPLETE SATISFACTION.** Prompt delivery of all the latest models.—R. Wigfield, Furlong Road, Goldthorpe, Yorks.

NEWNES BOOKS
 on
WIRELESS

Special free book repeat offer—
 Closing October 31st

THE WIRELESS CONSTRUCTORS ENCYCLOPEDIA

By F. J. CANN

Wireless terms and definitions stated and explained in concise, clear language by one of the best-known and most popular designers and writers on the practical side of wireless construction. Profusely illustrated. A veritable treasure of wireless knowledge.

5/- net (5/3 post free)

FIFTY TESTED WIRELESS CIRCUITS

By F. J. CANN

Modern circuits of practically every type from crystal to superhet. Diagrams and instructions for assembling and wiring. Details of components and notes on operation.

2/6 net (2/10 post free)

THE OUTLINE OF WIRELESS

By RALPH STRANGER

Here is a book which covers the theory and practice of Wireless Reception from A to Z, and makes everything plain even to the most "non-technical" reader. **WORLD-RADIO:** "Step by step, line upon line, precept upon precept, it teaches you everything you want to know about wireless." 816 pages: Lavishly Illustrated.

8/6 net (9/- post free)

THE MATHEMATICS OF WIRELESS

By RALPH STRANGER

This brilliant and experienced writer on Wireless has a happy knack of making even the driest and most abstruse topic interesting—and amusing! He has a characteristic way of handling mathematics which appeals irresistibly to those to whom previously the subject has seemed both difficult and dull.

5/- net (5/5 post free)

FREE In order to introduce our wireless books to the greatest possible market and to encourage the buying of technical books generally we recently offered a free copy of the famous wireless text book "Wireless for the Man in the Moon" (2s. 6d. net) to all purchasers of wireless books from our list to the value of not less than 5s. So many people have written to us making application for this book since our offer was closed, that in fairness to all kind enough to be interested we are extending the offer until October 31st. Order now from the above list and make sure of this delightful volume. Mark your envelope "Wireless Books Offer."

Book Dept. 8-11, Southampton Street, Strand London, W.C.2.

NEWNES : LONDON

EASY PAYMENTS

"THERE'S NO PLACE LIKE HOLMES." Monthly

	Deposit	Monthly Payments
W.B. 37 J	32 6 4/5	7 of 4/5
ROLA FI020 P.M.	38 6 4/-	9 of 4/3
CELESTION SENIOR 9	55/-	11 of 5/-
MAGNAVOX THIRTY-THREE 75/-	6/10	11 of 6/10

Any make of speaker supplied.
GRAHAM-FARISH SENSITY SUPER 50/- 4.7. 11 of 4.7
GRAHAM - FARISH ALL-WAVE KITS 57/6 5/3 11 of 5/3
SPECIAL.—G.E.C. universal mains A.C. or D.C. with M.C. Speaker, complete with valves in cabinet. List price, 28 10s. Our Price, 7s. deposit and 11 payments of 7s. 3d.
PARTS FOR ANY SET. ANY MAKE OF SPEAKER.
 New goods obtained for every order.
 Send us a list of parts or valves you require or any speaker or set you may select and we will forward you a definite quotation. Ten years' advertiser in the Wireless Press. Thousands of satisfied customers.
H. W. HOLMES,
 New Address :—333, EUSTON ROAD, LONDON, N.W. 1
 Phone: Museum 1414.

This Record-breaking achievement of a Customer in Cheshire is proof of the amazing efficiency of Clarion Valves. British-made, and yet only half the price of foreign, and a third that of "ring" valves. All types available from the Makers—hence low prices. 2-Volt Battery Type, H.2, H.L.2, L.F.3, 1/9 each; Super Power, P.2, 2/6 each. Screens and Pentodes, 3/9 each. A.C. MAINS, 4-VOLT, 1 AMP. General Purpose, 3/3; Power 4/- each; Screen and Pentodes 4/6. FULL WAVE RECTIFIERS 4/6 each. All post free, guaranteed and critically tested before dispatch. Cash with order or C.O.D. over 10/-. Data sheets on request. **CLARION RADIO VALVE CO.** (Dept. B.W.9), Tyburn Road, Edlington, Birmingham.

MISCELLANEOUS

"WORKING MODELS and How to Make Them." Edited by F. J. Cann, 3s. 6d.—This Book will appeal to all who are handy with tools. Contains complete instructions for the making of every kind of working model. Each model has been actually constructed in accordance with the details given and subjected to stringent tests. The instructions and diagrams are so clear that even the most elaborate model can be built without fear of failure. Obtainable at all Booksellers and Newsagents.—Geo. Newnes, Ltd., 8-11, Southampton Street, Strand, London, W.C.2.

FOR THE RADIO ENTHUSIAST.—"The Wireless Constructor's Encyclopaedia," by F. J. Cann (Editor of "Practical and Amateur Wireless"), third edition. Compiled by one of the most accomplished designers and writers on the practical side of Wireless, it covers the whole field. A veritable Treasury of Wireless Knowledge. Price 5s. from all Booksellers and Newsagents.—George Newnes, Ltd., 8-11, Southampton Street, Strand, London, W.C.2.

ADVERTISEMENT INDEX

Belling & Lee, Ltd.	202
British Institute of Engineering Technology	223
British Television Supplies, Ltd.	219
Bulgin, A. F. & Co., Ltd.	223
Clarion Radio Valve Co.	Inside Back Cover
Cossor A.C., Ltd.	197
Dubilier Condenser Co (1925), Ltd.	198
Electradix Radios	228
Farrer Radio, Ltd.	212
G. P. Co.	223
H.M.V.	Inside Front Cover
Healyberd, F. C. & Co.	202
High Vacuum Valve Co., Ltd.	223
Holmes, H. W.	Inside Back Cover
International Correspondence Schools	216
Jackson Bros (London), Ltd.	205
King's Patent Agency, Ltd.	223
Lectro Linx, Ltd.	205
London Radio Supply Co.	202
New London Electron Works, Ltd.	212
New Times Sales Co.	201
McCarthy Radio, Ltd.	228
Peto-Scott Co., Ltd.	211
Pico, Ltd.	205
Pix	225
Premier Supply Stores	227
Record Radio, Ltd.	223
T. & C. Radio College	215
Varley	202
Westinghouse Brake and Signal Co., Ltd.	212
Whiteley Electrical Radio Co., Ltd.	221
Wingrove and Rogers, Ltd.	198



THE Cyclist

To-day's **SPECIALLY ENLARGED** "CYCLIST" is a complete and lavishly illustrated guide to the cycling exhibits at the Show. Everything new is described and explained by experts.

★ If you cannot visit Olympia—this **SPECIALLY ENLARGED** Show Guide will bring Olympia to you!

Of all Newsagents and Bookstalls, or by post 4d. from the Publisher, George Newnes, Ltd., 8-11, Southampton Street, Strand, London, W.C.2.

GET YOUR COPY TO-DAY 3^D

George Newnes, Ltd.

SPECIAL AUTUMN NUMBER!

Don't Miss It!

POWERFUL & GLAMOROUS NEW STORY

"THE UNLOCKED DOOR"

By Andrew Wood

The Laughable Life Story of **LAUREL and HARDY**
BY THEMSELVES

THE GREAT LOVE STORIES BEHIND WORLD-FAMOUS PAINTINGS

By CLAUDE F. LUKE

£500 FOR HOUSE NAMES

Most Amusing of all Contests

LONG COMPLETE THRILLER

48 ALL-STAR PAGES

GET IT TO-DAY!

TIT-BITS

OUT NOW 2^D

Of all Newsagents and Bookstalls, or by post 3d. from the Publisher, George Newnes, Ltd., 8-11, Southampton Street, Strand, London, W.C.2.

George Newnes, Ltd.