

160

Practical and Amateur Wireless, October 12th, 1935.

24-PAGE SHORT-WAVE HANDBOOK INSIDE

Practical ^{3^D} and Amateur Wireless

Edited by F.J. CAMM

a GEORGE NEWNES
Publication

Vol. 7. No. 160.
October 12th, 1935.

AND AMATEUR TELEVISION



A
COMPLETE
SHORT-WAVE
GUIDE
Construction &
Operation

"CAN THERE BE A
BETTER SPEAKER?"

asks Mr. F. J. Camm.



1936 STENTORIAN

ADVT.

The

SET FOR DISCRIMINATING WIRELESS CONSTRUCTORS

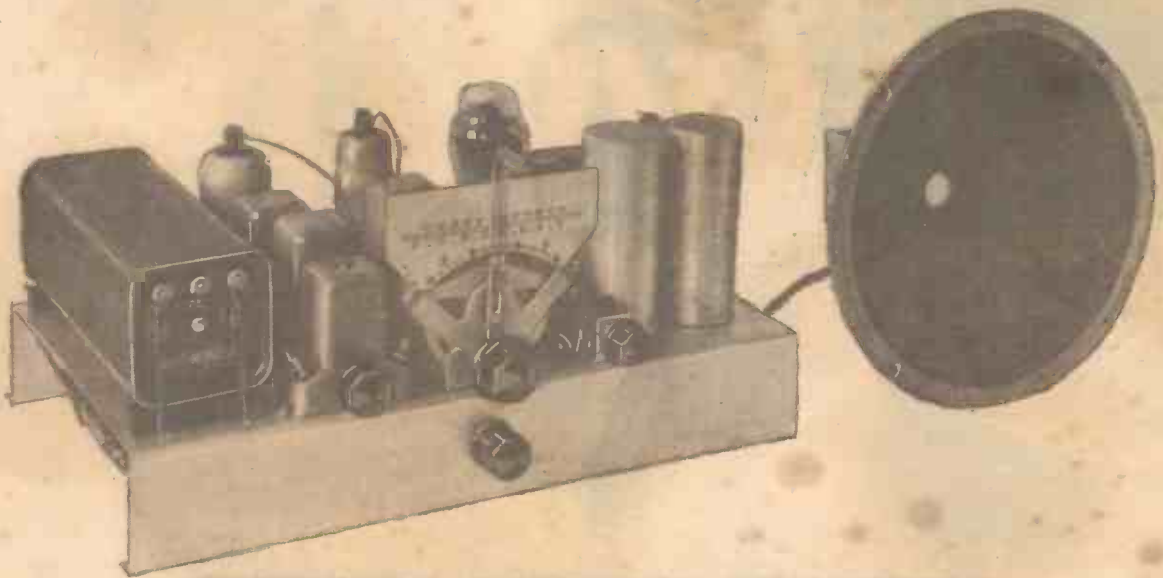

THIRTEEN STARRED FEATURES

- ★ 1. Designed by Westinghouse Engineers.
- ★ 2. Three-valve "reflex" superhet giving five-valve performance.
- ★ 3. Universal operation on A.C. or D.C. Mains.
- ★ 4. Westector 2nd detector.
- ★ 5. Westinghouse Metal Rectifier for H.T. supply.
- ★ 6. Automatic Volume Control.
- ★ 7. High Selectivity.
- ★ 8. Good Quality.
- ★ 9. 3-watts output.
- ★ 10. Very low "hum" level.
- ★ 11. Reception of at least eight stations during daylight.
- ★ 12. Reception of most continental stations during darkness.
- ★ 13. All components specially chosen for reliability and efficiency.



We have prepared a book giving comprehensive technical and constructional details of this fine receiver. It costs 1/- complete with blue prints. Get a copy to-day and start building the first low-price receiver to give quality reception of all stations worth listening to.

COUPON

WESTINGHOUSE BRAKE AND SIGNAL CO. LTD.,
82, York Road, King's Cross, London, N.1.

Name.....

Address.....

FRA. 12/10/35.



1

0 to 300 VOLTS

Three ranges of voltage readings are obtained with positive plug in the positive socket.



0 to 600 VOLTS

Voltage ranges are doubled by inserting the positive plug in the 6Ma socket instead of in positive socket.



RADIO SERVICING SIMPLIFIED
New Enlarged Edition

This invaluable book explains every phase of fault-tracing and testing in non-technical language. Multitudinous tests are so set forth as to be a matter of straightforward procedure. The comprehensive information and numerous diagrams enable everyone to test sets and apparatus with ease and success.

2/6 Post Free 2/9



Important to 32,000 users of the D.C. AVOMINOR

Regd Trade Mark

Do you know that the values of the three voltage ranges provided on the D.C. Avominor can be doubled if the positive plug is inserted in the 6Ma socket instead of in the positive socket? This means that actually six different ranges of readings from 0-600 volts can be obtained.

Thus the testing facilities provided by this famous instrument are virtually unlimited. The Avominor reveals the TRUE condition of circuits, valves, components, batteries and power units. You can test with an expert's precision, for the Avominor provides a standard of accuracy unobtainable in any instrument at anywhere near the price.

★ Actually the D.C. Avominor is 13 instruments in one, giving six different voltage ranges.

VOLTAGE

0-6 volts	0-12 volts
0-120 "	0-240 "
0-300 "	0-600 "

CURRENT

0-6 m/amps.
0-30 "
0-120 "

RESISTANCE

0-10,000 ohms.
0-60,000 "
0-120,000 "
0-3 megohms.

In case, with leads, interchangeable testing leads and crocodile clips, and instruction booklet. **40/-** Deferred Terms if desired.

Send for fully descriptive folder.

AUTOMATIC COIL WINDER & ELECTRICAL EQUIPMENT CO. LTD., Winder House, Douglas Street, London, S.W.1.

Tel.: Victoria 3404-7

Three Unicores . . .



For this — Mr. Camm's newest set—the "1936 Superperformer," have been chosen three Unicore Coils by Varley.

An unique coil, introduced at the Radio Exhibition, has already quite a large following among home constructors and others who are interested in modernising old receivers at a minimum cost. Catalogue No. BP.110.

FOR THE "1936 SUPERFORMER"

These coils are priced at Five Shillings. A Postcard to Woolwich will ensure prompt delivery.

Varley

Oliver Pell Control Ltd., Bloomfield Road, Woolwich, S.E.18. Telephone: Woolwich 2345



Every radio expert should know these facts about



1936 PEDIGREE RADIO

There is 37 years' experience in the design of sound reproducing instruments behind every radio receiver or radiogram which bears the "His Master's Voice" symbol. Be guided by this experience. When your non-technical friends ask you which is the best radio they can buy, recommend "His Master's Voice." There are fourteen radio instruments to choose from in the 1936 Pedigree range—and whichever they choose you can safely tell them they will get, at no extra cost, "His Master's Voice" tone at all volumes of sound, a cabinet which is a fine piece of furniture, noiseless tuning with easy station location, complete station s-e-p-a-r-a-t-i-o-n, devices which automatically counter fading and unwanted noise, and everything for full and untroubled enjoyment.

Here are two typical examples of the kind of value which "His Master's Voice" 1936 Pedigree Radio offers.

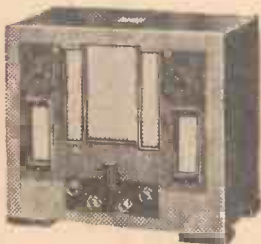

MODEL 442 RECEIVER
Five-valve (inc. rect.) AC superhet receiver with "fluid-light" tuning. AVC and static suppressor

13 1/2 Gns

MODEL 541 QAVC RADIOPHONE
5-valve AC superhet receiver with QAVC, giving silent tuning and combating fading on distant stations, and electrical gramophone

22 Gns



DON'T MISS THIS OPPORTUNITY - - POST NOW!

"HIS MASTER'S VOICE" 108J CLERKENWELL ROAD, LONDON, E.C.1.

Please send me your new book "A Camera Commentary on Radio in the Home" (with details of radio instruments from £7.19.6 to 110 guineas). This places me under no obligation. (Post unsealed—id. stamp).

NAME

ADDRESS

A STAR SET! F. J. CAMM'S SUPERFORMER FOUR



Practical and Amateur Wireless

Edited by F. J. CAMM

Technical Staff:
W. J. Delaney, M. J. Barton Chapple, Wh.Sch.,
B.Sc., A.M.I.E.E., Frank Preston.

VOL. VII. No. 160. October 12th, 1935.

ROUND *the* WORLD of WIRELESS

Radio Station at the North Pole?

NORWEGIAN papers state that several countries interested in Polar expeditions are studying ways and means to install a small radio station in the vicinity of the North Pole. An international expedition composed of technical experts is expected to leave for the Arctic Circle in 1936.

Germany's New Relay

WORK on the Reichenbach 5-kilowatt relay station is now almost completed, and it is expected that the transmitter will be brought into operation in the course of the next three weeks. It will take the Breslau programmes and will work on 243.7 metres, a channel already used by Gleiwitz.

PTT, Nice, Testing

ON 253.2 metres (1,185 kc/s), namely, between the Frankfurt-am-Main common wave and Copenhagen, listeners may now hear nightly tests carried out by France's latest 60-kilowatt transmitter on the Mediterranean. Announcements are frequently made both in French and English, and the broadcast usually closes down with a gramophone record, *The Dance of the Cuckoos*, of which the first bars may be temporarily adopted as an interval signal.

Television in Paris

WITH a view to the extension of French television broadcasts, the Ministry of Posts and Telegraphs is installing a 10-kilowatt transmitter on the top of the Eiffel Tower, Paris. It will be completed in about six months and will work on 7 metres on a 180-line screen. In the meantime, a temporary station will start a daily service from November 10th.

Europe's Radio Listeners

DENMARK, with 160 licence holders per 1,000 head of population, tops the list, with Great Britain in second place, possessing 14.7 receivers owned by every 100 inhabitants. Sweden follows with 11.8; Holland, 10.9; Germany, 9.4; Switzerland, 8.8; Austria, 7.8; Belgium, 7.4; Norway, 5.5; and Czechoslovakia, 4.6. Italy, with ten stations and a population of forty-two millions, shows only 1 per cent.

Australian Flying Doctor Service

A CENTRAL radio station has been established at Cloncurry (Victoria), and is in communication with settlers' homes equipped with small transmitting and receiving sets. By this means, in the event of accidents and serious illness a radio-equipped aeroplane with doctor can be sent immediately to any district within an area of 700 miles.

Moscow's Proposed "Super" Station

THE Soviet authorities who, for several years, have fostered the ambition of possessing the world's largest radio station, are now putting their plans into concrete form. They are constructing a transmitter at Chadinka, which, when completed, will be rated at 2,500 kilowatts. So far, no information is available as regards the channel to be used.

Bristol Radio

UNDER the call letters GJB, the Air Ministry has opened a new aircraft direction-finding transmitter at Bristol. It is working on 862 metres (348 kc/s), and may be heard in communication with planes daily from G.M.T. 07.00-20.00.

Radio Masts that Made History

THE two 450ft. steel masts of the original B.B.C. Chelmsford station are being dismantled. They were used for the first musical broadcast carried out in 1920, two years before a regular broadcast service was established. It was also from this aerial that the short-wave station, G5SW, transmitted the first Empire programme on Armistice Day, 1927.

New Transmitter for Bolzano

ALTHOUGH the Italian authorities had at the outset planned a 10-kilowatt station at Bolzano, it has now been decided to endow the district with a station of double that power. It will be built in the neighbourhood of Appiano, on a hill overlooking the lake of Monticolo. It will not be ready for many months.

Will Brazil be Heard?

AS broadcasts from the Argentine Republic, in particular Buenos Aires, are being picked up between B.S.T. 02.00 and 04.00, a search for transmissions from Brazil may meet with some success. Rio de Janeiro is the only city possessing 25 kilowatts, and it might repay to try for PRH2, 500 metres (600 kc/s), or PRA9, 300 metres (1,000 kc/s).

South Africa's New Relay

A 10-kilowatt station has been opened at Pietermaritzburg, to relay the Durban programmes. Its call-sign is ZTP and its wavelength 430.4 metres (697 kc/s).

Mr. F. J. CAMM'S Superformer Four

is the Set of the Season!

+ + +

Its construction is fully described on pages 109 to 116 of this Issue.

+ + +

Superhet on Short Waves,
Straight on Medium and Long Waves!

B.B.C. Orchestra to Play Abroad

IN the near future, the B.B.C. Orchestra, under the direction of Dr. Adrian Boult, will visit Vienna and Budapest for a series of concerts of English compositions.

Germany's Most Powerful Station

THE Leipzig transmitter which, after reconstruction, is now being brought again into daily operation, has also been equipped with a new aerial system. As it is working on 120 kilowatts, it is Germany's most powerful station.

ROUND the WORLD of WIRELESS (Continued)

"I Spy"

THE first broadcast of a Melliish burlesque, "I Spy," will be heard by Midland listeners on October 9th. Martyn Webster will produce, and Reginald Burston will conduct the B.B.C. Midland Orchestra and B.B.C. Midland Revue Chorus. In amusing dialogue and lively verse the Melliish Brothers "take off" the conventional ingredients of the spy story—Russian adventuress vamping a young politician, doped wine, and stolen plans. There is a comical denouement when the plans are finally recovered.

Military Band Contest

THE annual Championship Military Band Contest takes place this year on October 12th, and on October 17th the winning band will broadcast to Northern listeners.

"La Bohème"

THE London and Provincial Opera Society Limited, from the Royal Opera House, Covent Garden, are presenting Puccini's opera "La Bohème" on October 15th, and the second and third acts will be relayed to Northern listeners from the Empire Theatre, Liverpool.

"Musical Extravaganza"

HENRY REED and Ben Morton, Junior, the young Manchester lyric (libretto) writers, have again collaborated in writing a second "Musical Extravaganza," to follow up their recent success, "Music Shop." This new show, which is to be broadcast to Northern listeners on October 16th, constitutes, in fact, the second episode of "Music Shop." Its sub-title is "After Dark," and it will consist of popular songs sung by burglars and other surreptitious visitors to the music shop after closing time.

"The Quaintesques"

BILLY MANDER'S (All Male) Concert Party "The Quaintesques" (including the "Quaint Six Novelty Band") will broadcast again to Northern listeners from Leslie's Pavilion, Rusholme, on October 17th.

String Orchestral Concert

A STRING orchestral concert will be relayed from the Reardon Smith Lecture Theatre of the National Museum of Wales on October 15th. Eda Kersey (violin, will be the solo artist, and the Strings of the Western Studio Orchestra (augmented) will be conducted by Reginald Redman.

Light Fare from Carlisle

AN excerpt from a variety bill will be broadcast to Northern listeners from Her Majesty's Theatre, Carlisle, on October 18th.

INTERESTING and TOPICAL PARAGRAPHS

Northern Philharmonic Orchestra

A CONCERT by this popular orchestra, conducted by John Barbirolli, will be relayed to Northern listeners from the

LISTENERS FROM THE EAST



Some interesting visitors from China listen to one of the latest Cossor receivers.

Town Hall, Leeds, on October 19th. The soloist will be Adolph Busch, the well-known German violinist.

Variety from Edinburgh

VARIETY for Scottish listeners on October 15th comes from the Edinburgh studio, when the programme will be

SOLVE THIS!

PROBLEM No. 160

Smithers had a three-valve battery receiver which had given splendid results for many weeks. One evening, when he switched on, no signals could be heard. He tested the batteries and found these in order, and all connections seemed to be intact. He removed the earth lead and this made no difference. He replaced the earth lead and removed the aerial lead, and was surprised to hear faint signals, which could be brought fairly loud by the use of the reaction control. When, however, the aerial lead was replaced signals again disappeared. What was wrong? Three books will be awarded for the first three correct solutions opened. Envelopes must be addressed to The Editor, PRACTICAL AND AMATEUR WIRELESS, Geo. Newnes, Ltd., 8-11, Southampton Street, Strand, London, W.C.2. Envelopes must be marked Problem No. 160 in the bottom left-hand corner, and must be posted to reach this office not later than the first post Monday, October 14th, 1935.

Solution to Problem No. 159

Marshall was using the one-valver as a short-wave adapter and therefore should have taken the output lead to the anode terminal of the first valve in his three-valver. He was endeavouring to use it as a converter, but there was no provision for frequency changing in the circuit and thus the combination would not function in the way in which he tried it.

The following three readers successfully solved Problem No. 158 and books are accordingly being forwarded to them: G. Oldhall, 89, Grosvenor Road, Handsworth, Birmingham 20. Q. Lloyd, Great Dixter, Northiam, Sussex. F. Keeble, 28, Katherine Road, East Ham, E.6.

provided by Ian MacLean (comedian), Horace Wilson (tenor), Janette Sclanders (soprano), Jan Wien (banjoist), and Napp and Mack (comedians). James Urquhart, Elsie Brochie, and Ian Sadler will take part in a sketch, "The Carrying Code," by Jack House and Allan MacKinnon, and the programme will be supported by Harry Carmichael and his Band and Barbara Laing at the piano.

"The Sack at 18!"

MIDLAND PARLIAMENT resumes its deliberations on October 14th. The subject to be discussed is the young entry into industry, and the title of the first discussion "The Sack at 18?" indicates one of the problems. Later a scheme, which can be summed up in the phrase "a life-ticket for industry," will be examined. Such questions as whether employers should be licensed, and whether each firm should be required to take its quota of young workers who are not above the average in ability, will be debated. Sir Charles Mander, Bart., of Wolverhampton, will again act as informal chairman.

A Novel Broadcast

FOLLOWING the success of the Stanelli Stag Parties and others put on by well-known radio artists, the ladies have demanded that they shall be given an opportunity to display their talents without the assistance of males at the microphone. A distinguished cast of these girl radio stars is to be assembled on October 17th in the National programme. The party will follow the lines of its successful predecessors, all the announcing and compèring being done by the ladies themselves.

Concert for Scottish Listeners

ON October 15th a concert for Scottish listeners will be given by the New Light Orchestra (leader, Harry Carpenter), conducted by Ian Whyte. The orchestra will play "Marche Joyeuse," by Chabrier; Overture, "Oberon," by Weber; "Song before Sunrise," by Delius; and "Welsh Rhapsody," by German; and Robert Watson, the well-known Scottish baritone, will sing an interesting group of songs by D. R. Oppenheimer, including "Meeres Stille" (Goethe), "Schlummerlied" (Volkslied), "Wanderers Nachtlied" (Goethe), "Come unto these yellow Sands," and "Full Fathom Five."

Musical Programme for Midland Listeners

THE outstanding musical programmes of the week will be a studio performance of "The Shepherd of the Delectable Mountains" on October 14th, and a relay of the City of Birmingham Orchestra in "Music of the Reign," on October 19th. The former work is by Dr. Vaughan Williams.



Straight or Superhet?

An Explanation of the Relative Advantages and Disadvantages of the Two Main Circuit Types

By FRANK PRESTON

THE controversy as to whether the straight circuit or the superhet arrangement is to be preferred has been going on for upwards of ten years, the verdict first being in favour of one and then being reversed in favour of the other. If an opinion were asked of the average listener to-day, he would probably say that the superhet is vastly superior, and probably that the straight circuit—apart from its use in simple types of set—is obsolete. As evidence of this he would no doubt point to the many commercial receivers on the market and explain that nearly every one of these employs the superhet system. It might be added that a superhet is far more selective as well as being more sensitive, whilst providing at least equal quality of reproduction. But sound though these simple arguments may at first appear, the position to-day is not quite so simple as might at first be imagined. It is for this reason that it is proposed to throw rather more light on the subject, so that readers may draw their own conclusions with a greater degree of accuracy than, perhaps, they can at the moment.

Functional Differences

For the benefit of the less technical-minded reader it would perhaps be desirable first of all to explain very briefly the essential differences between a superheterodyne and a straight circuit, so that the later remarks will better be appreciated. In a straight circuit of the better-class type there are two high-frequency stages which amplify the signals exactly as received by the aerial; these stages are followed by a detector which eliminates the carrier wave, leaving only the audio-frequencies corresponding with the original sounds; finally there is the low-frequency amplifier

which builds the rectified signals up to sufficient volume to operate the speaker.

The position is entirely different with a superhet, for in this case the signals picked up by the aerial are first partially rectified, after which another oscillation of different frequency from that of the original signals is applied to the rectified signals. The new set of oscillations must be at a frequency different from that of the signals by an amount equal to that at which the next

or 650 metres. After I.F. amplification, the signals are passed to the second detector, again rectified, and then amplified in the usual manner.

Why the Superhet Became Popular

The present wave of popularity of the superhet commenced something like three years ago, and the chief reason was that at that time it was not an easy matter to obtain stable amplification at frequencies

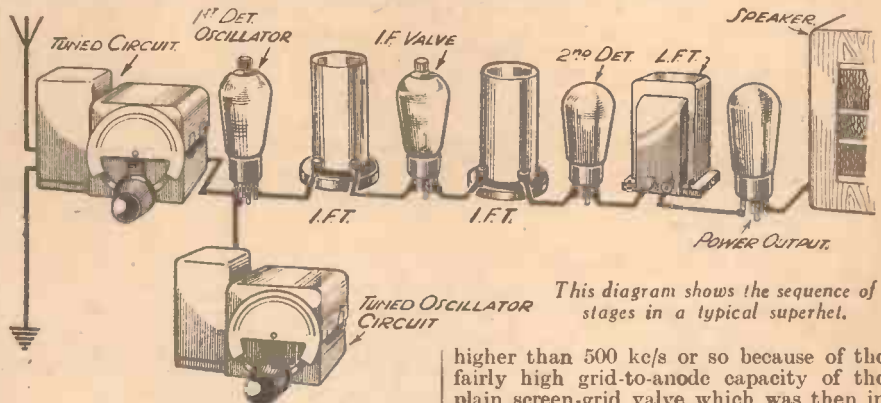

This diagram shows the sequence of stages in a typical superhet.

amplifying stages (the I.F. amplifier) operate. The frequency may be 110 kc/s, 150 kc/s, 465 kc/s, or any other convenient figure, although the three mentioned are most commonly employed. It will be seen from this that the oscillator must be tuned at the same time as the first detector, but that it must always tune to a different frequency. The output from the combined first detector and oscillator is applied to the intermediate-frequency amplifying stages and is tuned to the same frequency, regardless of the wavelength or frequency of the transmission being received. The intermediate frequency is comparatively low, being equivalent to a wavelength of approximately 2,700 metres, 2,000 metres,

higher than 500 kc/s or so because of the fairly high grid-to-anode capacity of the plain screen-grid valve which was then in use. Because of the difficulty in obtaining the required degree of stability at the higher signal frequencies the superhet offered an easy and fairly satisfactory solution. Additionally, a greater degree of selectivity could be obtained with the average superhet arrangement, since the pre-tuned I.F. amplifier would not accept signals which were not exactly in tune. Moreover, by using, say, three I.F. transformers, each of which comprised a separate band-pass tuner, the set had eight separately tuned circuits—six in the I.F. amplifier, the tuned aerial circuit, and the tuned oscillator circuit. At the period in question selectivity was becoming

(Continued overleaf)

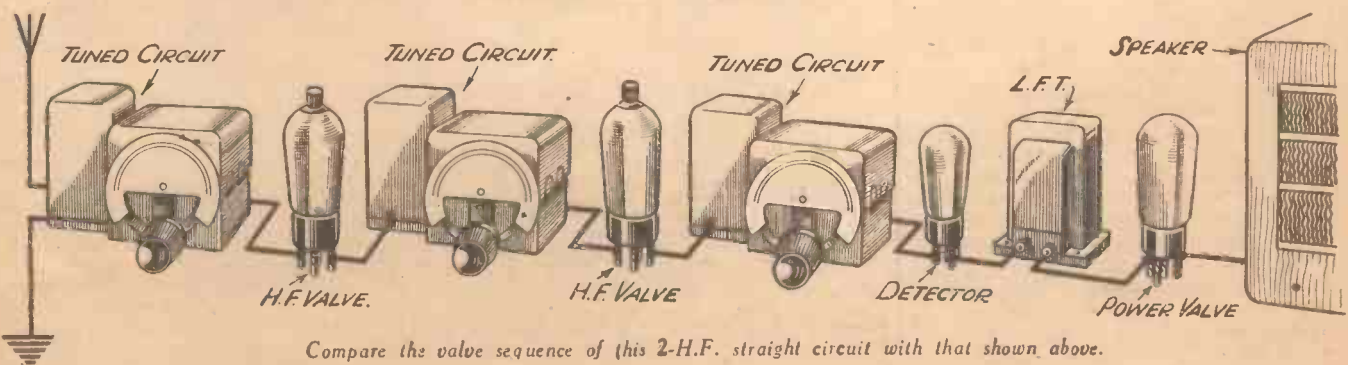

Compare the valve sequence of this 2-H.F. straight circuit with that shown above.

STRAIGHT OR SUPERHET ?

(Continued from previous page)

extremely important, and the superhet was found to be ideally suited to the existing conditions.

There was yet another objection to the straight circuit, which was that, even when it was made extremely selective, interference was very often experienced due to what is known as "cross-modulation." This only occurred when using S.G. valves, and was caused by the powerful signals from a comparatively nearby transmitter modulating the carrier wave of a weaker station working on a wavelength not far removed from that of the "local." Incidentally, this was overcome by the perfection of the variable-mu valve.

Another important point was that with a straight circuit the quality of reproduction was often spoiled by increasing the degree of selectivity, due to the fact that the side-bands were cut and the higher audio-frequencies lost. To a certain extent the band-pass tuner overcame this trouble, but not completely, because this type of tuner as then used did not show the same degree of selectivity over the full range of wavelengths which had to be covered. Consequently, although the band-pass tuner responded to the full range of frequencies at one portion of the tuning scale it did not do so at others. On the other hand, if the tuner were adjusted so as to cover the necessary frequency band at one wavelength it might not provide sufficient selectivity at another. Parallel with the effects just mentioned was that of inconstancy of the sensitiveness of the tuning circuits at different wavelengths; just as selectivity varied over the tuning range so did sensitivity, although generally in the opposite manner.

Superhet Disadvantages

We have seen now how the superhet was justly proclaimed as being better

than the straight circuit of a few years ago, but we have not yet considered the disadvantages of this type of circuit, chiefly because they were originally far outweighed. Nevertheless, the superhet does suffer from the "chirps" heard at certain points on the tuning dial, and which are due to second-channel interference; this is inseparable from the average superhet, although it can be minimised by using a high intermediate frequency. Another objection is that it is in many cases almost impossible to obtain perfectly accurate tracking of the oscillator tuning circuit over the two wavelength ranges. In other words, it is an extremely difficult matter to maintain the same frequency difference between the oscillator and first detector tuning circuits. And inaccuracy here means that sensitivity must suffer at certain wavelengths, that some distortion must be introduced, or both. This is not an important matter in the simpler type of superhet, as was amply demonstrated by the famous £5 Superhet, but it does frequently become serious, and it does certainly add to the difficulties of the inexperienced constructor when making the preliminary adjustments to his set. It involved the use of pre-set condensers for padding and tracking which must be tuned with a degree of accuracy which is not always possible without the use of calibrated oscillators or other laboratory equipment.

For a superhet to give perfectly uniform results on all wavelengths to which it is tuned would necessitate a variation in intensity of the output from the oscillator as the tuning condenser is operated, and this is nearly impossible to arrange. On weak signals the local oscillations may be far too strong in relation to those of the received signal, the result being that the signal cannot be received at all, or that it is distorted badly.

Where the Modern Straight Set Scores

We have not made out a very strong case for the reversion to the straight set, but all the original objections to this type of receiver have been well-nigh overcome with the introduction of variable-mu H.F. pentodes and band-pass filters consisting of two iron-core coils with combined capacity and inductive coupling, and which provide uniform sensitivity and selectivity over the full range of wavelengths. The straight set is slightly easier for the home constructor to build, and it is certainly easier to trim and adjust. Add to this the fact that it uses simpler and less expensive types of valves, and that it can easily be designed to respond to the same band width over both long- and medium-wave ranges, when it will be seen that, for use on the broadcast bands at any rate, it has now more to recommend it than has the superhet. Bearing these facts in mind, it might justifiably be expected that the highly-sensitive, high-quality straight receiver with two H.F. stages and band-pass tuning will return to popular favour.

All-wave Working

Conditions are considerably different on the short- and ultra-short waves, and here the superhet is still supreme. The chief reason is that high-frequency amplification is practically impossible—it is at least inefficient—at signal frequency, with the result that I.F. amplification is invaluable in a long-range easy-to-operate receiver. Besides, tracking troubles are not so much in evidence, particularly when using an intermediate frequency of 465 kc/s.

It will now be evident why, in designing the Superformer four-valve receiver described in this issue, it was decided to make the set so that it functioned as a highly-efficient straight set on medium and long waves, and as a superhet on short waves.

Changes in Circuit Design

Notes on Some of the More Important Developments of the Past Year

DURING the past year there have not been many novel or startling changes in the design of circuits, and the only really interesting departure from previous arrangements is to be found in the superheterodyne receivers. Here, owing to the experience which has been gained from the popularity of this type of receiver, various failings were found in the circuit as it had been originally presented. Thus, in addition to the improvement effected by the multi-valve known as the heptode or pentagrid, it was found worth while to improve the I.F. transformers, and new intermediate frequencies have been introduced. The use of the superhet on short waves has resulted in a new frequency for the I.F. stages and the 465 kc/s components are now as popular as the original 110 kc/s components used to be.

Variable Selectivity

It has also been found that the normal fixed selectivity provided in this type of circuit is not all that can be desired when quality as well as selectivity is required, and thus special I.F. transformers have been produced in which the degree of coupling between primary and secondary may be varied (either on the component itself or from a panel control), and thus the degree of selectivity kept under the control of the user.

The double valve known as the triode-heptode has also resulted in the introduction of a different type of circuit.

Tuning Coils

A noticeable change in the type of tuning coil which has been produced during this period is seen in the fact that a large number of air-core coils have been placed on the



One of the recently-produced variable selectivity I. F. transformers

market. This must not, however, be taken as an indication that the iron-core type of coil is not so good as was at first thought, but is due to the fact that there has been a return to favour of the simpler type of receiver in which the iron-core coil cannot give of its best. Research has been carried on with regard to this important part of the receiver, and it has been found that there are several points in this component which can be improved, and there is every possibility that in the near future we shall see a completely new type of tuning coil, following lines which have previously been hinted at but have been discarded.

Straight Circuits

Elsewhere in this issue will be found a discussion regarding the relative merits of the superhet and the straight type of circuit, and it will be seen that the latter has many points to recommend it, and these have resulted in the last few months in a return to favour of this type of receiver, together with an increased use of the cold type of rectifying valve, or Westector. Our 1936 Sonotone is an example of this type of circuit, and reports show that this is likely to push the superhet right out of court where general high quality on a fairly average number of stations is required. Naturally, however, for the listener who requires dozens of stations at all times of the day, and is not concerned with a very high standard of quality, the superhet still holds the premier position, but events tend to show that this phase of wireless listening is passing and high quality is going to be the keynote of future designs.

Trouble-Tracking Made Easy

In this First Article of the Series, Methods of Testing Various Components are Given. By I. EVANS

DURING recent years receivers have gradually become more complicated, in order to cope with the necessity for increased selectivity. There has also been a tendency to use one or more dual-purpose valves in the majority of receivers. It is not surprising, therefore, that partial breakdowns often occur in modern sets, even though the standard of reliability of most components has steadily been improving. Fortunately, however, it is possible to trace the majority of faults by means of a combined meter of the volts-milliamperes type, as the measurement of the voltage and current at various vital points in the receiver will enable the owner to localise the defective component. The home-constructor has a definite advantage over the commercial set owner when a breakdown occurs, of course, as he knows the receiver circuit arrangement and the purpose of each component. To facilitate the speedy tracing of defects in PRACTICAL AND AMATEUR WIRELESS receivers, we introduced our Service Data Sheets a few weeks ago. As we expected, these are proving very popular, and thousands of readers have written to us in appreciation of this unique innovation. It would seem, however, that beginners are unable to make full use of the data sheets owing to their having insufficient knowledge of routine testing methods, and therefore it has been decided to give a series of articles on systematic fault-tracing during the next few weeks. If these articles are carefully perused, and the information given is used in conjunction with the particulars on the data sheets, readers should have no difficulty in tracing the faults which may occur in our published designs.

Component Testing

When building a receiver it is advisable roughly to test the components before assembly, for although these are carefully tested by the manufacturer, damage often occurs in transit. This is particularly so in the case of inductance components, such as coils, transformers, and chokes, as the very fine wire used in these is easily damaged. As a general rule it is only necessary to test these components for continuity, as in nine cases out of ten the defect which occurs is a broken wire in one of the windings.

Transformers and Coils

An easy method of testing transformer continuity is shown in Fig. 2. As indicated, the milliammeter should be connected in series with the transformer winding and a small battery. A cheap meter is suitable for this test, but readers who do not already

possess a meter are advised to obtain a moving-coil instrument. These meters are more expensive than the moving-iron type, but are more reliable for general test work, and are therefore a good investment. The majority of L.F. transformers have a primary winding (P. to H.T.) resistance of approximately 500 ohms and a secondary winding (G to GB) resistance of approximately 1,500 ohms. If a milliammeter having a full-scale deflection of 10 mA is used, a 4½-volt grid-bias battery will therefore be suitable for testing purposes. A definite kick of the meter needle when the battery plug is inserted will indicate that the winding is not broken. If it is desired to measure the actual resistance of the winding, Ohm's Law must be applied. This law states that resistance (in ohms) is equal to voltage (in volts) divided by current (in amperes). For example, if a

and therefore care must be taken to use a low voltage for testing purposes.

Breaks in coil and high-frequency choke windings are often experienced, due in most cases to the wire attached to the terminal tags being twisted too tightly. As the resistance of coil windings is very low, however—between approximately 1 and 25 ohms in the case of medium- and long-wave windings—the method adopted for transformer testing cannot be used, as a sufficiently low voltage cannot be obtained. To test coil continuity it is therefore necessary to connect a resistance in series with the milliammeter, as shown for the condenser test in Fig. 1. If a 10 mA meter and a 4½-volt battery are used, a one-watt resistance having a value of 1,000 ohms will be suitable. The resistance of the coil is negligible as compared with that of the extra resistance, and therefore a reading of approximately 4½ mA should be obtained. The exact resistance of the winding cannot be measured by this simple means, of course, but the measurement of the D.C. resistance of a coil is not very important as the inductance is not entirely governed by the resistance. High-frequency chokes may be checked for continuity in exactly the same manner as coils, and as in the case of the coil winding the actual resistance cannot be accurately measured by a milliammeter. As mentioned above, however, the usual defect in coils and chokes is a broken winding and therefore a continuity test will suffice.

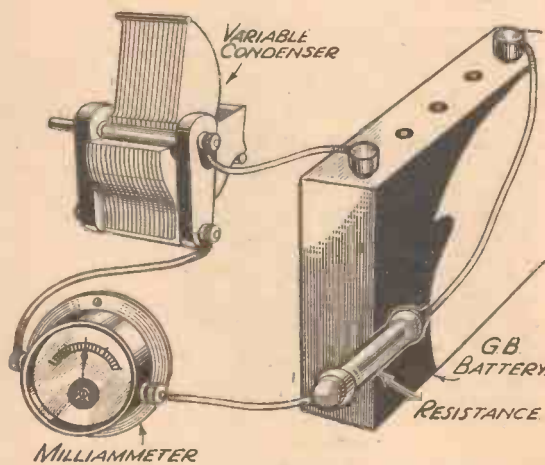

Fig. 1.—Testing a condenser for short circuits.

battery of 4½ volts is used, and the meter registers 9 mA, it will indicate that the resistance of the winding is 500 ohms. Likewise, a reading of 3 mA with the same battery in use will indicate a winding resistance of 1,500 ohms. When making the preliminary test it will be advisable to use a lower voltage, say 1½ volt, in order to avoid damage to the meter should the transformer winding resistance be very low. If an abnormally high current reading is obtained it will indicate that there are shorted turns in the transformer winding—this, by the way, is not an uncommon defect. Low-frequency chokes can be checked in the same way as transformers, but in the case of output chokes the resistance is sometimes as low as 200 ohms,

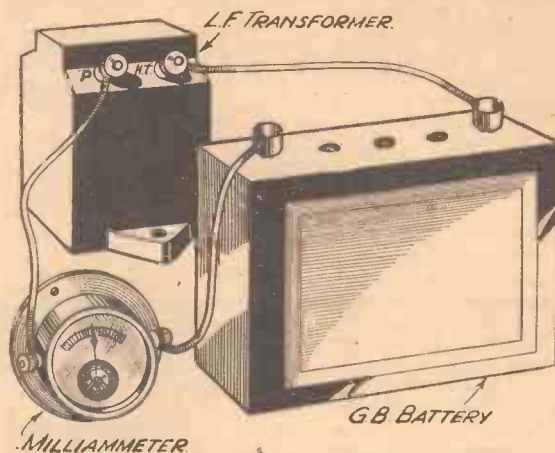

Fig. 2.—Showing method of testing transformer continuity.

Condenser Tests

Variable condensers work on the principle of one set of vanes moving in or out of a set of fixed vanes, with the air (or solid insulating material) in between the vanes acting as a dielectric. It is therefore essential that the vanes do not come in contact with each other. Owing to the close proximity of the fixed and moving vanes in the modern midget condensers it often happens that they touch each other at certain points during rotation. It is therefore advisable to test these components before assembling them. This can be done as shown in Fig. 1, using a milliammeter, a 1,000 ohms resistance, and a 4½-volt battery. If the condenser is in order no reading will be registered, but if there is a short between the fixed and moving plates at any point a reading of 4½ mA will be obtained.

Radiogram Refinements

Although the Modern Gramophone Record is a High-class Product, it is Possible to Improve the Performance Obtained from it by various means. Interesting Details are given here

EVERYONE who is anything of a gramophile knows that the modern gramophone record may be regarded as a masterpiece of musical recording. When, for instance, you hear such records as the Aldershot Military Tattoo, or some of the modern band recordings with organ accompaniments or obligatos, it seems incredible that the various tones and musical effects could be impressed on the disc of wax. Yet, if one of these records is played, for instance, on a small portable gramophone, it sounds altogether different from what one hears on a modern electric radiogramophone. Why is this? Simply because the portable instrument of the acoustic type relies upon a mica diaphragm at the base of a small horn for the production of the various effects, whereas the electric radio-gram converts the sound waves on the record into electric impulses, which may be passed through amplifiers, modified, added to, various ranges suppressed, and in other ways altered so that the performance reaches a remarkably high standard.

Recording Faults

Dealing first with the method of recording, it is probably now well known that, owing to the fact that the grooves on a record are equally spaced, it is impossible to record the low frequencies at the correct value. Thus, the method of recording is compensated, so that as the frequencies decrease so the amplitude of the recording decreases, and thus the bass notes are not of the same "strength" as the higher notes. Similarly, at the upper end it is necessary to avoid certain frequencies which might be ruined by surface noise, or the sound made by the needle travelling over the record. The very high frequencies cannot be recorded at all, as the variations in the grooves would be so minute that they would be knocked off by the needle as the record rotated. In spite of all this, however, the effects are there, and even without compensation they give a remarkable reproduction. When, however, we employ an electrical pick-up, in conjunction with a tone compensator, we can reproduce all frequencies at more or less the same strength, and thus bring back the music or other item to its original balance.

Tone Compensators

The majority of modern pick-ups have the curve of reproduction so designed that

By W. J. DELANEY

there is a rise in the bass to compensate for the above-mentioned cut-off. Unfortunately, there are resonances in the needle and armature and these generally

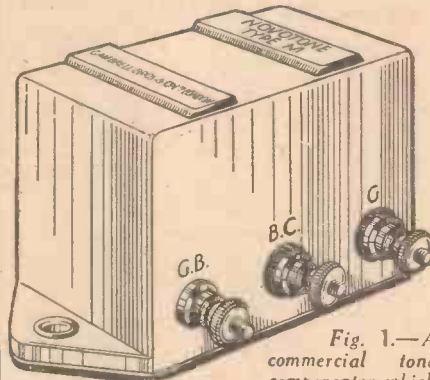

Fig. 1.—A commercial tone compensator which will improve the balance of reproduction from gramophone records.

tend to heighten the sound known as needle scratch, or the noise made by the needle rubbing on the record. To augment the first-mentioned feature of a pick-up, it is possible to obtain a special tone compensator consisting of chokes and condensers which have been chosen to operate

with an ordinary type of pick-up in inverse ratio to the method used in recording. That is to say, instead of the lower notes being suppressed they are over-amplified and thus brought back to a strength comparable with the middle and treble notes. By means of suitable condensers even the output from these compensators may be modified so that any desired type of reproduction is obtainable. These compensators are known as Novotones, and may be obtained from Messrs. Gambrell (Fig. 1).

Scratch Filters

To avoid the sound of the needle scratch special chokes and filters are obtainable from well-known firms, but a simple filter may be constructed by the amateur from an ordinary H.F. choke, a resistance, a potentiometer, a condenser, or combinations of these components. Figs. 2 and 3 show methods of arranging a scratch filter, and in each case the value must be chosen to suit the particular type of pick-up which is being used, and therefore some experiment may be found desirable to obtain a suitable value. Where the amplifier employs a pentode output valve the scratch filter will be especially necessary, and the usual tone control across the output of the pentode should not be omitted.

Beyond the question of modifying the response curve, there are other refinements which will add to the comfort of the gramophile as well as in many cases adding to the life of the record. Firstly, it is essential that the needle be always placed on the outside (plain) edge of the record and gently pushed towards the centre until it picks up the spiral tracks. If the needle is placed on the track damage will result, and in time the record will start with a distressing noise. A small pilot light should therefore be mounted on the motor-board so as to cast a ray of light across the record and illuminate the spot where the needle is placed down, and the device supplied by Messrs. Bulgin and illustrated in Fig. 4 will be found very valuable in this connection.

A needle should only be used once (unless of the permanent or semi-permanent type), and to guard against the use of a used needle double needle cups should be mounted on the motor-board, and that for the used needles should be provided with a lid.



Fig. 4.—A refinement which will lengthen the life of records—an illuminator for the turntable.

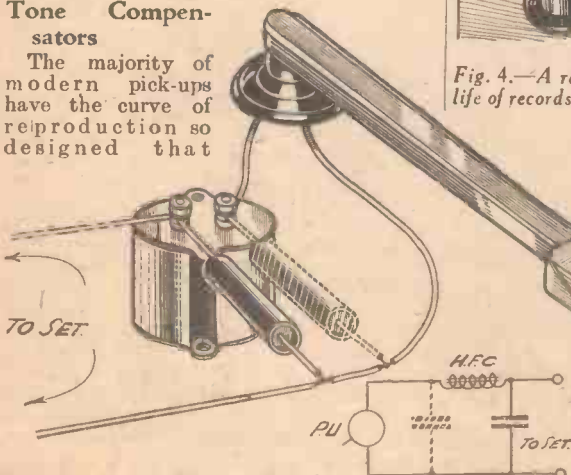

Figs. 2 and 3.—Two suggested scratch filter arrangements, shown in pictorial and theoretical form.

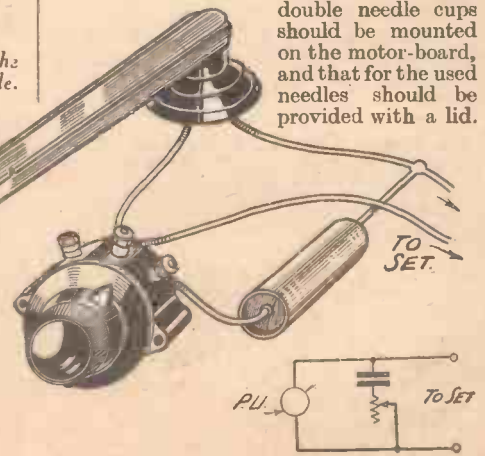

A PAGE OF PRACTICAL HINTS

SUBMIT YOUR IDEA

READERS WRINKLES

THE HALF-GUINEA PAGE

A Triple Baffle Board

HAVING accumulated a number of baffle boards during the past years of experimental work, I was at a loss to know how to dispose of them till I hit on the following idea. I arranged three of these boards in order of magnitude, one behind the other, screwing the corners only of the smaller on to the back of the larger, at the same time inserting a thick rubber washer (cut from 1/4 in. sheet rubber) in each corner in order to separate

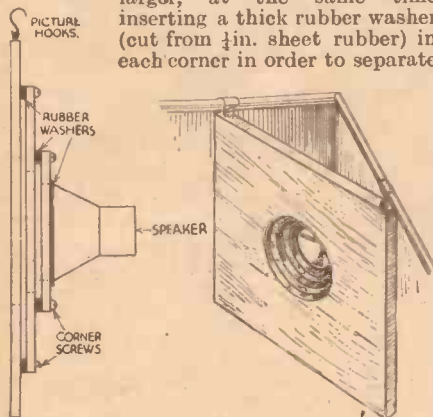

Method of fitting up a triple baffle board.

the boards. A moving-coil speaker was then screwed to the smallest board, and this again (in addition to its existing washer) had a thick rubber washer between its edge and the board. The entire apparatus was then hung from picture hooks in the corner of a room. Anyone making a speaker housing of this type will have a pleasant surprise, for the results are remarkable.—C. CROWLEY (Birmingham).

A Short-wave Hint

MANY short-wave enthusiasts operating a short-wave superhet adaptor in conjunction with a broadcast receiver of the H.F.-det.-L.F. type have no doubt suffered inconvenience by reason of the fact that the adaptor has to be removed

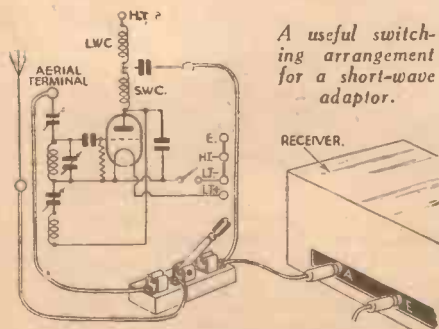

A useful switching arrangement for a short-wave adaptor.

before the set can be operated on the broadcast band. The following switching arrangement obviates this trouble. The anode of the adaptor valve is permanently connected to the aerial terminal of the broadcast receiver through the usual

THAT DODGE OF YOURS!

Every Reader of "PRACTICAL AND AMATEUR WIRELESS" must have originated some little dodge which would interest other readers. Why not pass it on to us? We pay £1-10-0 for the best wrinkle submitted, and for every other item published on this page we will pay half-a-guinea. Turn that idea of yours to account by sending it in to us addressed to the Editor, "PRACTICAL AND AMATEUR WIRELESS," George Newnes, Ltd., 8-11, Southampton Street, Strand, W.C.2. Put your name and address on every item. Please note that every notion sent in must be original. Mark envelopes "Radio Wrinkles." Do NOT enclose Queries with your Wrinkle.

short-wave choke and small fixed condenser. The adaptor is, of course, connected to the H.T. and L.T. batteries, but a switch must be incorporated in the adaptor to cut them off when the short-wave side is not in use. The receiving aerial is then connected to the arm of a S.P.D.T. switch, one side of which is connected to the aerial

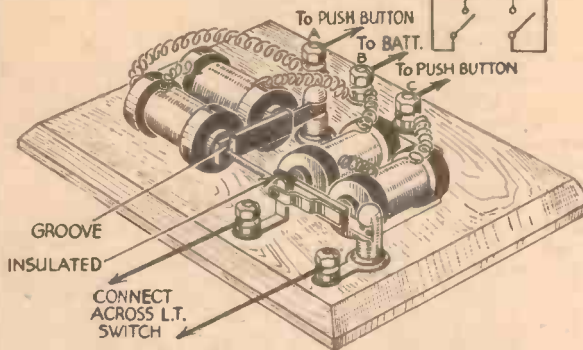

A remote control relay made with electric bell parts.

terminal of the adaptor and the other to the aerial terminal of the receiving set. One has only to switch the aerial over from the set to adaptor or vice versa to bring in the short-wave or broadcast band at will, the adaptor H.T. and L.T. being switched on only when the short waves are being received. The H.F. losses on the short waves will not be serious if a substantial switch of reputable make is used. An advantage is that the set and adaptor may be housed permanently in the same cabinet.—G. W. GILL (Rugby).

Remote Control On-off Relay

THE following materials are required for the construction of this useful device: Two cheap bells (battery type), two push-buttons, and a 4.5-volt battery, these irrespective of the piece of wood for mounting and five terminals (which are usually found in the junk-box).

Part of the ironwork of the bell should be cut away with a hacksaw, and reference to the illustration will make the reason apparent. The rest of the assembly is also self-explanatory. The only difficulty which will arise is that of adjustment, but a little patience will overcome this with ease. The 4.5-volt battery gives snappy operation of both relay and cut-out.—W. R. HOLDEN (Ilford).

Converting a Dial

THE ordinary type of circular slow-motion dial may be converted in a simple manner to provide all the advantages of the more up-to-date full-vision straight-line dials in the following manner. First of all remove the dial entirely from the receiver, and to the moving-scale portion fit a screw in the manner shown in the sketch. A piece of tubing (which may be made up quite roughly from tin-plate if desired) is then taken and slipped over the operating spindle, and round this is wrapped a length of thick copper wire. This is twisted and then passed between two washers fitted to the screw on the dial, or otherwise held in this position in such a manner that when the dial rotates the pointer will be moved freely without any jamming. When the required distance has been found the remainder of the wire is twisted and one end cut off. The remaining end is dipped in black enamel or other suitable material and cut to such a length that it will be fully visible when passing across a rectangular scale cut to suit the particular receiver. In the sketch a panel 5 in. by 2 in. is shown, but this may be modified if desired. The station names are printed on this panel, and the pointer will give a large movement for a small adjustment of the control knob, and if desired the original window may be left to provide degree readings for "searching" purposes.—L. M. BARNES (Hurlingham, S.W.6).

PAPER SCALE MOUNTED ON CELLULOID OR GLASS

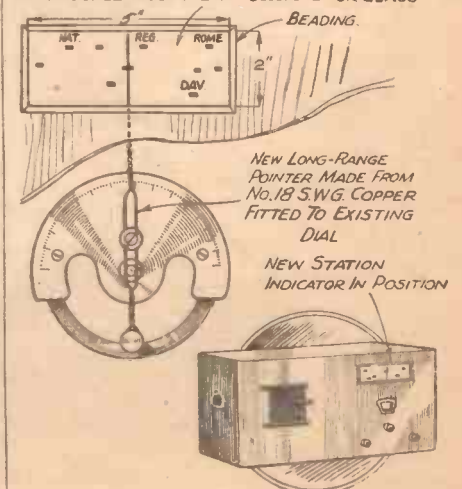

Converting a slow motion dial to a full vision type.

EXTERNAL DESIGN

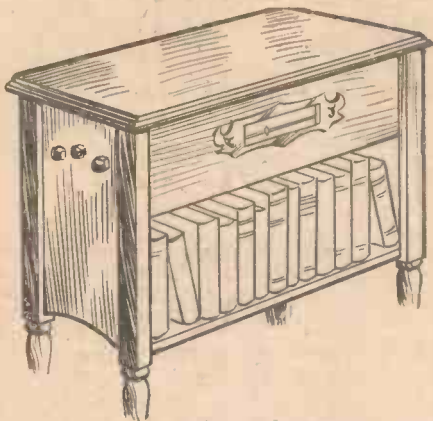

A neat scale in front, and hidden side knobs are the features of the set shown here and built into a "utility" cabinet.

GR**EAT** as have been the improvements in circuit design and in the design of components, it appears that there is still ample scope for improvement with regard to the cabinet work, the position of the speaker and the disposition of the controls. Many novel tuning scales have made their appearance recently, and most of these simplify tuning by making the divisions more readily visible; at the same time, however, the scales are often placed in such positions that they can only be seen by twisting the head into an uncomfortable position. Knobs, too, have been beautified—even made easier to hold—but their positions are generally such that they do not come readily to hand when the receiver is placed in its normal position.

Where the Constructor Scores

It is presumed that the manufacturers of complete receivers have designed the cabinet work according to the expressed wishes of customers, but, for the sake of economy in production, they are obliged to standardise one particular design. And although this might meet with the approval of many users, it may be quite unsuited to others. There is probably no easy solution so far as the commercial receiver is concerned, but matters are entirely different in the case of home-built receivers, for the constructor can easily obtain a cabinet to suit his own tastes regardless of the design of the receiver chassis.

One of the first questions to be settled in considering the cabinet design is whether the speaker is to be housed in the same container as the set itself, or is to be kept external to the receiver. In nearly every case it is slightly more convenient to have the speaker in the same cabinet as the set, but the quality of reproduction may be appreciably impaired, especially if the cabinet is not unusually large (radiograms excepted) and if it is made of thinish wood. It is definitely worth while to keep the speaker as a separate unit which can be moved about until the best position in the room is found. Apart from giving increased efficiency, this scheme has the advantage of reducing fairly considerably the size of the receiver.

The next point which comes up for consideration concerns the position which the set is to occupy: is it going to be placed on a high shelf?; will it be stood on a small, low table or stool?; is it to be

General Notes on the Design of the Cabinet Work, and on the Arrangement of the Controls

provided with legs so that it forms a piece of furniture on its own?; or—if of a portable nature—is it intended to have the set mainly on the floor beside the favourite armchair? There are many other similar questions which one might ask oneself, but those mentioned are of most importance.

A Question of Height

It would obviously be ridiculous to have the knobs projecting from the front of the cabinet if the set is to be stood on the floor or on a low table, for it would then be necessary to stoop and twist the neck every time it was desired to change from one station to another, or even to adjust the volume control. A far better arrangement in such a case would be to have the controls on the top of the cabinet, where they can easily be operated, and where the tuning dial is most easily seen. Obvious though this point is, it is apparently overlooked by many constructors who do not realise that the receiver chassis can just as well be placed vertically as horizontally. Those who prefer to have the speaker in the receiver cabinet might argue that this system would be bad because it would necessitate the mounting of the speaker unit at the base of the cabinet instead of at the top. This argument is very feeble, though, because with the set in the position

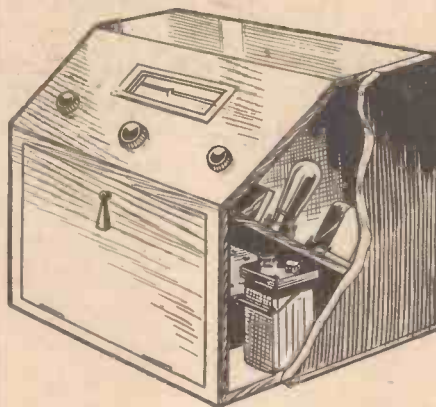

An excellent cabinet arrangement where the controls are on a sloping panel.

mentioned the speaker would be too low for best results in any case. Incidentally, it might be mentioned that the best position of the speaker is with the axis of the cone in line with the ears; this means that the unit should be mounted at ear level (when sitting), or that the speaker should be placed higher than this and tilted downward. In most instances, and in small rooms, the latter position is to be preferred.

In the early days of broadcasting it was the custom to make the set in desk form with the controls on a sloping panel. It seems a pity that this idea ever died out, because it gives an ideal control position when the set is about waist high. There

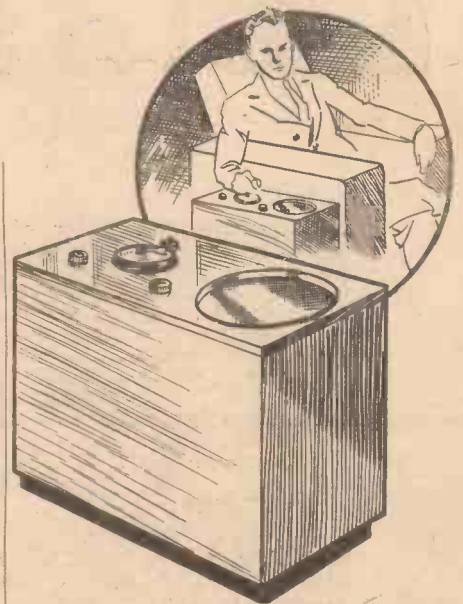

This shows a form of construction which is ideal for a transportable receiver for operation from the armchair.

is no reason why the scheme should not be revised, however, either by sloping the top of the cabinet or by fitting a sloping panel. In either case the receiver chassis can easily be mounted on sloping wooden runners screwed to the inside of the cabinet. This tends to increase the size of the cabinet in some instances, but by careful design it is generally possible to utilise the space below the chassis for storing the batteries or for the mains unit. When this is done a further refinement may be added in the form of a door in the front of the cabinet, through which access can be gained to the batteries and also the underside of the chassis—the latter is a great advantage.

Those who like the portable or transportable type of receiver will find it an excellent plan to have it beside the chair at such a height that the controls are immediately below the hand. This really means that the chassis must be turned through ninety degrees and the cabinet either made deeper than usual or arranged to fit on a small stool of suitable height. This arrangement is feasible even when a built-in speaker is used, for quite good results are generally obtainable with the speaker pointing upward.

"Utility" Cabinets

Mention has not yet been made of the type of cabinet which, in addition to containing the receiver, acts as a piece of utility furniture such as a bookcase, clock, cocktail cabinet or bureau. In most instances, however, the same principles as have been referred to above apply with equal force, although it might be desirable to conceal the controls when they are not in use. This can generally be done by means of a sliding panel or lid which may be "camouflaged" as an ordinary fixed panel. An alternative is to use an ornamental scale and to place the knobs on a side of the cabinet where they are not normally visible.

COSSOR *de luxe*

A.C. MAINS 'SUPER-FERRODYNE'

REGD.

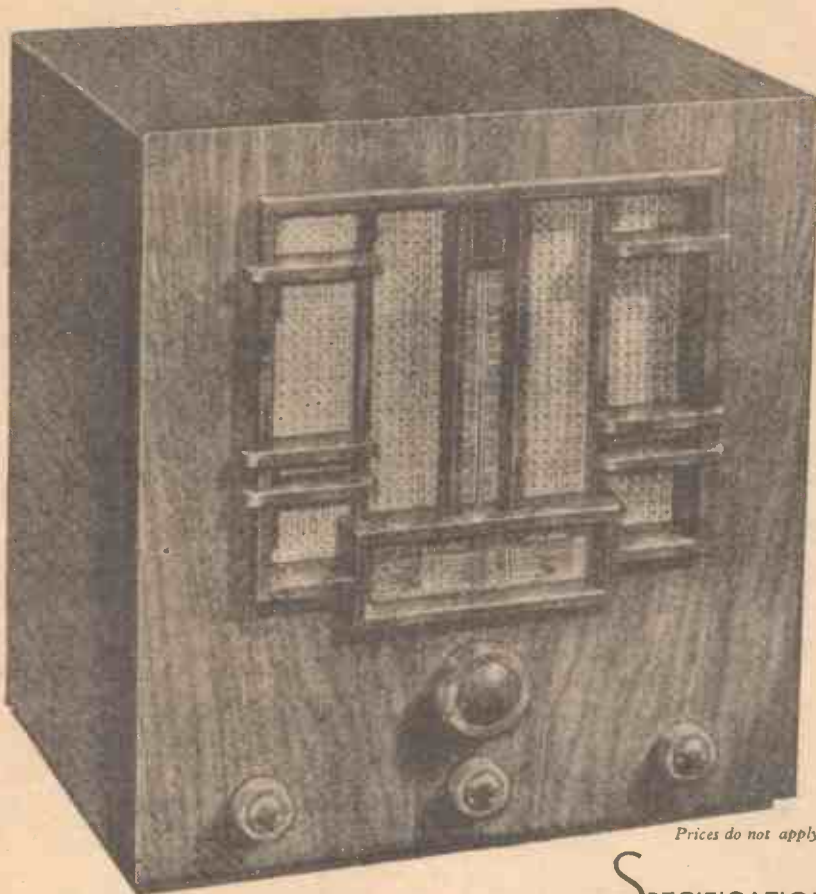

MODEL
367

TRIPLE SELECTOR CIRCUIT

VARIABLE-MU SCREENED
H.F. PENTODE

H.F. PENTODE DETECTOR

DIRECTLY-HEATED
POWER PENTODE
OUTPUT

"THERMOMETER"
TUNING

8" ENERGISED MOVING-
COIL SPEAKER

Prices do not apply in I.F.S.

Quality is the keynote of this fine Receiver — quality performance — quality appearance; and, manufactured throughout by the Empire's largest self-contained Radio factory, it is above all reliable.

The latest application of the Cossor 'Super-Ferrodyne' developments, special super-selective coils, a Screened H.F. Pentode stage — and an H.F. Pentode Detector permit even greater selectivity. And with it, increased sensitivity, resulting in a yet wider choice of interference-free programmes. Hear, and prove it to-day at your usual wireless shop!

SPECIFICATION: — Complete with Variable-Mu Screened H.F. Pen., Screened H.F. Pen. Det., Directly-heated Power Pen. Output, Heavy Duty Rec. Fully screened super-selective Coils. "Thermometer" Tuning with illuminated scales in wavelengths and engraved with station names. Combination "on-off" wavelength and gramophone pick-up switch. Selectivity control and Volume control. 8" Mains Energised M.C. Speaker. Handsome walnut-finished cabinet 15½" x 14½" x 10½" with bakelite fret. Terminals for pick-up. Twin plug and sockets for extension speaker. Station name-plate is readily changeable in the event of alterations in wavelengths. For A.C. Mains only, 200-250 volts (adjustable), 40-100 cycles.

9½ GNS

Hire Purchase Terms: 17/- deposit and 12 monthly payments of 17/-.

COUPON TO A. C. COSSOR LTD.,
Melody Dept.,
Highbury Grove, London, N.5.

Please send me free of charge, literature giving full particulars of the new Cossor A.C. Mains 'Super-Ferrodyne' Receiver Model 367.

Name

Address

L.165.

PRAG. 12/10/35

(CA) 7573

THIS COUPON BRINGS FULL PARTICULARS



Under Pressure

It's when the attack is fiercest that a goal-keeper proves himself. And it's *under pressure* that you should judge a battery. Siemens Full O' Power battery maintains quality and tone . . . under the heaviest load . . . for month after month of trouble-free service.

FREE BOOKLET WITH 1st LEAGUE FOOTBALL FIXTURES and full battery information. Ask your dealer or write to address below.

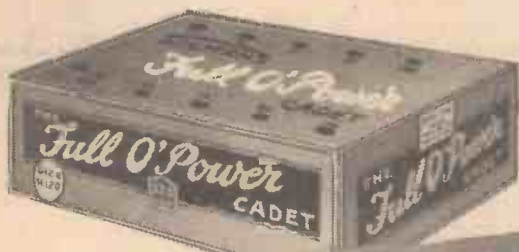

CADET TYPE			STANDARD RANGE—SUPER TYPE		
H.60	60 volts	3/9	H.1	60 volts	5/6
H.99	100 "	6/3	H.2	108 "	9/6
H.108	108 "	6/9	H.3	120 "	10/6
H.120	120 "	7/6	POWER TYPE—VERTICAL		
H.G.120	111 v.+9GB.8/9		V.4	60 volts	8/-
H.L.120	120 "	7/6	V.8	120 "	16/-

SPECIAL REPLACEMENT BATTERIES ARE AVAILABLE FOR EVERY TYPE OF SET

Advt. of **SIEMENS ELECTRIC LAMPS AND SUPPLIES LTD**
38/39, Upper Thames Street, London, E.C.4.



STARTLING NEW REALISM

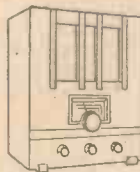

THE A.C.S. TABLE MODEL
Seven stage Superhet. 2.6 watts output. Full A.V.C., and Image Suppression. Energised Moving Coil Speaker. 12 gns. Radiogram AC5G. 21 gns. Either on easy terms.

THE 'POPULAR' SPEAKER

Keenest priced full size Moving Coil Speaker on the market—and it's Blue Spot! Ten point matching. Price 19/6. 7" cone. In Cabinet with volume control 35/6.

For years the best sets have had Blue Spot speakers. Now Blue Spot are building their own sets—and building them, naturally, with a simply unique knowledge of the circuit a speaker needs. The result is positively startling! A realism altogether new in radio! Insist on hearing one of the four Blue Spot models. Above is the Battery III—a sensitive, quality instrument with an acoustic output equivalent to 1 watt. Unwanted Programme Rejection circuit; Full Vision 45-name Dial; Walnut Cabinet—all for £6.17.6. Post the coupon (1/2 stamped envelope) to-day.

£6.17.6
or 12-monthly (see reverse)



Trade Mark

To The British Blue Spot Co., Ltd.,
Sterling Works, Dagenham, Essex.

Tell me about the New Realism in Radio.

A NEW REALISM IN RADIO

Name

Address

The British Blue Spot Co., Ltd.,
Sterling Works, Dagenham, Essex.



On Your Wavelength

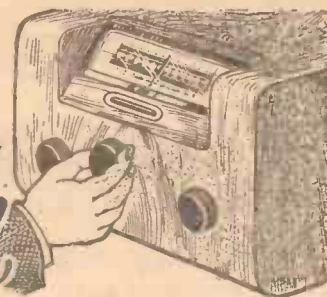

By Jhermion

Running-in

I HAVE often noted when testing new commercial receivers that they seem to function better after they have been in use for an evening or so. A receiver came to hand the other day. It was a well-known radiogram, and when switched on the reproduction was woofy and I could only receive two stations on the long-wave band and about five on the medium-wave band. No amount of coaxing would improve that, and I therefore switched over to test the performance on the radiogram side. Here again I was disappointed, for the volume control needed to be at its maximum setting before adequate volume could be obtained, and even then the quality left a lot to be desired. I changed back again to the medium-wave band and found that one or two more stations trickled in, which must have been broadcasting in my original test. Changing over to the long-wave band, I noted a corresponding increase in the



Hundreds of letters in the W.P.B.

number of stations received. The following evening the performance gradually improved, whilst on the third evening my total log was thirty-five stations on the medium wave-band and six on the long-wave band. This leads me to wonder whether valves take a little time to attain optimum results. The poor results could not have been due to strangeness of controls, since I am quite accustomed to handling strange receivers. Have any of my readers experienced this phenomenon?

A Television Pamphlet

BEARING in mind the Television Committee's Report, which was fully summarised in this journal some months ago, I am astonished to learn that the Radio Manufacturers' Association has published a pamphlet which has been distributed free of charge by radio dealers throughout the country. This pamphlet bears the innocuous title: "Television. Answers to Customers' Enquiries," and we are told that it represents the voices of authority and that both the public and the trade can accept all the statements made as being official and authoritative. I would remind

my readers that it was not permitted by the Radio Manufacturers' Association for any exhibitor to show television apparatus, nor for any firm to distribute television literature, apparently because it was felt that it might destroy the sales of sound-broadcast receivers. I should have thought that any trader who wished to answer customers' inquiries would do so by quoting the Television Committee's Report or by referring the customer to it. This Report was specially published for that purpose, and I quite fail to see why it should be necessary for the R.M.A. to have issued a separate pamphlet. The questions and answers given in it leave some questions unanswered and raise a whole heap of others. I invite you to slip round to your nearest wireless shop, ask for a copy of this pamphlet and for the dealer's views thereon. If you would oblige me by communicating his views and yours to me, I shall feel indebted. The vital question which every listener is asking is whether the television service will scrap his present receiver, the answer to which is obvious.

Large Tuning Scales

TUNING scales get larger and larger, for no apparent reason. Of themselves they cannot make a set more selective, the only advantage seeming to be that you are able to have the station names arranged in larger type and to read them more easily. A disadvantage is that a set with reasonably sharp tuning has an apparent band-spread.

A Fuse Point

A GREAT deal of confusion can arise with regard to the correct selection of a fuse, and the following point should be borne in mind when fitting a mains receiver in the house. I am mentioning it as a result of an accident which I heard of recently. The fuses mounted on the house fuse-board are probably of the 5-amp. type and thus the point into which the wireless receiver is plugged may be considered as being safe up to this figure. However, in many cases a long, flexible lead is provided from the wireless set to the mains socket, and some listeners use a fused-plug for connecting purposes, or rely upon the 5-amp. fuse in the mains lead for protection. A moment's thought will show that should a short-circuit develop which will cause a sufficiently high current to pass through the long flex, there is a risk of this burning out at some point between the set and the mains socket, and if the flex (as in the case I referred to) is long and drapes along a carpet, there is every possibility of the burn-out setting fire to the carpet. A kink in the flex may cause a weak point which will arc when the short takes place,

and the cotton covering of the flex will catch and thus set fire to the carpet. Therefore, use fuses at the receiver end of the flex, or use one of the commercial types of fuse connector which may be obtained from any good radio store.

My Healthy Post

MY Private Secretary (unpaid) is beginning to kick at the amount of letters I am receiving and which I deliberately encourage. I shall have to appoint another one, also unpaid, to cope with it. My post has been considerably augmented by the jazz-crooning correspondence on which I do not propose to comment this week, except to hint that there are signs that jazz music will fall into its deserved desuetude, for which large mercy, thanks be. Of course, rude letters reach me, but I have a capacious W.P.B. for them. I have noted from some of these letters that many of my readers seem to be clairvoyant, for they are able to foretell my future and to convey accurate details of my past and the nature of my death. The future for me, judging from these letters, is black indeed. All of them are agreed that it will be painful and untimely, the wish obviously being father to the thought. I am going to be shot, taken for a ride, beaten up, lynched,



The dial sells the set.

poisoned, given the woiks, or in one of a variety of other ways known only to those who follow jazz, am I to suffer a violent death.

Even now I have to creep about and select my restaurant with circumspection. I daily grow a furtive look, and have that haunted feeling which assails those with guilty consciences. Would that I could retract what I have written against jazz! Past life and the spoken word is beyond recall, but I am not so certain regarding the neglected opportunity!

A Shock

NOT from a mains receiver, but from an experience I had the other day when visiting a well-known restaurant in the Strand. I was enjoying my customary roll and cheese, which is all that I am permitted to purchase with the editorial munificence (the reward for my mental pabulum), and reading the current issue of this journal; adjacent to me was a secretive-looking individual whose hand slowly approached my arm and indented the flesh surrounding my ulna. "I see you are one of the brethren," he said. With my heart knocking like

(Continued overleaf)

(Continued from previous page)

a tink-a-pout motor cycle, I asked him what he meant. Pointing to the journal with an accusing finger he said "That!" Unfortunately it was open at my page, and fearing that a pro-crooner had at last tracked me to my lair, I grasped the revolver I am compelled to carry with me. Relief came when he asked what set I was using. He was a keen reader of the paper and discussed its features intelligently. My discomfort was not reduced when he referred to *this* feature. He asked me if I knew who Thermion was, to which I was compelled to reply that I had a very good idea! Asked my opinion as to his writings, mere honesty compelled me to say I thought it high-class literature. His face contorted at this; I think the food was disagreeing with him. I shall have to carry my lunch in a red handkerchief in future.

Why Not a Set in an Umbrella?

MANY novel arrangements have been suggested for portable wireless receivers, but no one so far as I can trace has yet built one into an umbrella, and bearing in mind the natural aerial it provides, I wonder someone has not incorporated a midget three-valver, particularly as so many songs have invited the idea.



Spotted!

That soul-stirring ditty, "It ain't going to rain no mo'" would cheer one no end during a thunderstorm, whilst if some obliging band would pump out at an appropriate moment, "Come Under the Old Umbrella," you have the ingredients of romance, should a pretty damosel pass by and seek refuge from the deluge. So much better than the hackneyed "Haven't we met before?"

The batteries of such a set could be accommodated in the pocket, two wander plugs mating up with suitable sockets in the crook of the handle, which also could accommodate a midget loud-speaker. Should anyone adopt this suggestion, I merely ask for a ten per cent. royalty, and that a national monument be erected to me in return for the idea.

"Practical Television and Short-Wave Review"

HAVE you seen our sister journal, *Practical Television and Short-Wave Review*, which is published monthly at 6d.? Although television is not promised until January, there is a wealth of information in it on television and allied sciences. The imminence of the new television programmes makes it necessary for every reader to gain a knowledge of the fundamentals, and he cannot do better than purchase a copy of this new journal, which also covers short-wave work.

Exit Radio Parade

THE small privately-owned broadcasting station at Parede, Portugal, which has been operating for over two years on 291 metres, has been completely destroyed by fire. In view of the new scheme put forward for the reorganisation and development of the Portuguese broadcasting system, it is not likely that it will be rebuilt.



Fitting Dial Lights

MOST modern tuning dials are fitted with lamp sockets so that dial positions can easily be seen even if the set is used in a darkened room. There seems to be some confusion amongst readers concerning the method of wiring these lamps, however. In the case of the battery set a bulb of the .1 amp. two to four-volt type may be used, and should be connected to the two filament terminals of one of the valve-holders. It is emphasised, however, that as a bulb of this type consumes one-tenth of an ampere—the same as the normal H.F. or detector valve—the accumulator will run down a little quicker when the light is used. It is possible, of course, to fit a switch in one of the leads to the lamp socket, so that the lamp may be switched off when not required; this procedure is particularly recommended if an accumulator of the small mass plate type is used.

When the set uses four-volt A.C. valves, a bulb consuming between .1 and .5 of an ampere may be used, and the tags of the bulb-holder should be connected to the heater terminals of one of the valves. In this case, the consumption of the bulb is so low compared with that of the receiver valves that a switch is not necessary. In the case of the universal A.C./D.C. receiver the valves are wired in series and, therefore, the method of wiring the dial-light differs from that used in the case of the A.C. and battery sets. In some cases the light is connected across the mains, but the easiest method of wiring a light to an existing set is to break the lead to one of the valve heaters, and then connect the two free ends to the tags of the lamp socket. The lamp must be chosen to suit the particular valves in use; for example, if .2 amp. valves are used the dial light should be of the .2 amp. type.

Split Vanes

IN order to obtain an effective degree of selectivity with a straight set it is necessary to use at least three tuned stages. Even if three are used it is essential to employ very selective coils if stations are effectively to be separated. The more tuned stages one uses the more necessary it becomes to trim the H.F. circuits correctly, and although modern coils and tuning condensers of reliable make are very well matched, it is very desirable to use condensers having split end vanes in order to obtain perfectly accurate matching at all points on the tuning scale. This type of condenser has its end vanes split into four or five sections, which can be moved slightly inwards or outwards so as to correct any small discrepancies in the tuning components. It is also found that most reaction condensers have a slight effect on the tuning of the stage to which the reaction circuit is coupled. When ultra-selective tuned circuits are employed it is therefore necessary to discard the variable reaction control. It may, however, be used as a pre-set control in order to improve the sensitivity and the selectivity of the receiver.

Realistic Reproduction

A CONDENSER at a frequency of 50 cycles is one hundred times as great as at 5,000 cycles. It is easy to see, therefore, that where an audio-frequency signal is required to pass through a condenser, the lower frequencies will be seriously attenuated, while if a capacitive leakage path exists, the losses of the higher audio frequencies will be the most serious. In the case of inductive circuits the effects are just the reverse, a series inductance tending to produce loss of high notes, and a shunt inductance producing low-note attenuation.

A McMichael Customer from Overseas

WE are frequently hearing of the very unusual people who make use of radio nowadays, and many of the large firms have interesting tales to tell of their dealings with out-of-the-ordinary folk.

McMichael Radio seem to have a good share of this type of business, probably due largely to their original S.W. equipments, and to the stress which they have always laid on McMichael reliability. Whatever the cause, explorers, big-game hunters, mountaineers, and many other such people are constantly dropping in to see them.



Set in an umbrella.

A week or two ago McMichael's received an intimation that another of these strange customers was interested; the Sheik of Kuwait, an oil-potentate from the Persian Gulf, was returning home after a prolonged Jubilee visit to England and wished to send certain members of his suite down to Slough to inspect the works, and in due course three Oriental technicians (?) toured the McMichael Works, were duly entertained, and presented their report to His Excellency. A few days later the Strand Showrooms of the firm were surprised and gratified by the sight of the Sheik himself, complete with staff and interpreters, in quest of a demonstration. The Model 235 super-het at 12 guineas was finally chosen and a special carrying case was ordered for it.

Guards' Bands in Hyde Park

TWO months ago, it may be remembered, Columbia issued a record of the Hyde Park Thanksgiving Festival, which echoed the Jubilee Celebrations; this month they follow it up with another disc featuring the massed bands of H.M. Coldstream and Welsh Guards, conducted by Major Andrew Harris, which is a remarkable "open air" recording. The titles they play are Sir Walford Davies' "Solemn Melody" and the specially written "Homage March," by Haydn Wood. The pieces are rousingly played and the tone is naturally of the big, "open air" character. The number of this record is Columbia DX695.

Radio War in Yeovil (Somerset)

THE Town Council has threatened to veto the use of wireless loud-speakers in Council houses after 11 p.m., in consequence of which wireless enthusiasts and their next-door victims are at loggerheads. If complaints continue to be lodged the bye-law will be brought into operation.

Obtaining Variable Selectivity

Methods of Altering the Degree of Selectivity Provided by Simple Types of Receiver are Described

By BERNARD DUNN

DUE to the greater demand for high-quality reproduction, variable selectivity has come very much into the limelight of late, but it would be wrong to consider that this is a new development. What is new is the provision of a convenient panel control for changing the band width of tuned circuits to suit the degree of selectivity required. Until recently, such components as intermediate-frequency transformers were either designed to have a definite fixed band-width response, or else any control for altering this was on

affected to any great extent. This point is of particular importance when a gang condenser is employed. Another simple form of selectivity control is shown in Fig. 2, where a variable resistance is connected between the aerial and earth leads on the coil. As the resistance value is decreased tuning is flattened and sensitivity reduced.

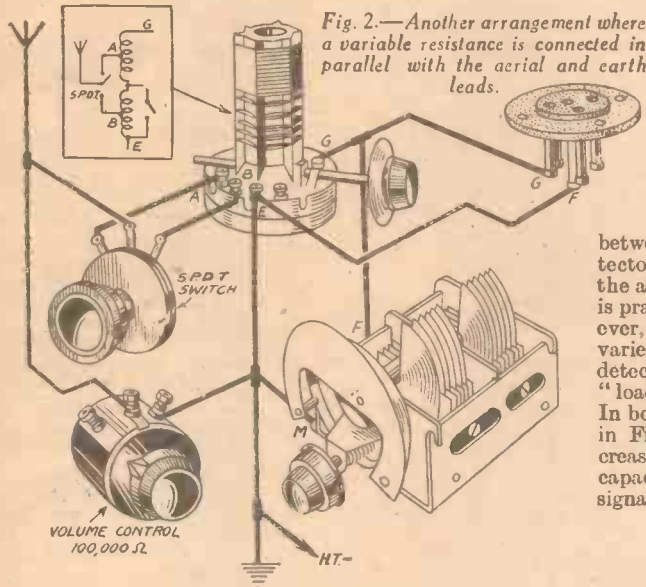

Fig. 2.—Another arrangement where a variable resistance is connected in parallel with the aerial and earth leads.

Maintaining Constant Sensitivity

Another arrangement is shown in Fig. 3, this being similar to that in Fig. 1, with the exception that the differential condenser is included between the H.F. and detector valves, instead of in the aerial circuit. The effect is practically the same, however, for the condenser varies the input to the detector and also varies the "load" on the tuned circuit. In both this circuit and that in Fig. 1 selectivity is increased as the condenser capacity is reduced, and signal strength is increased

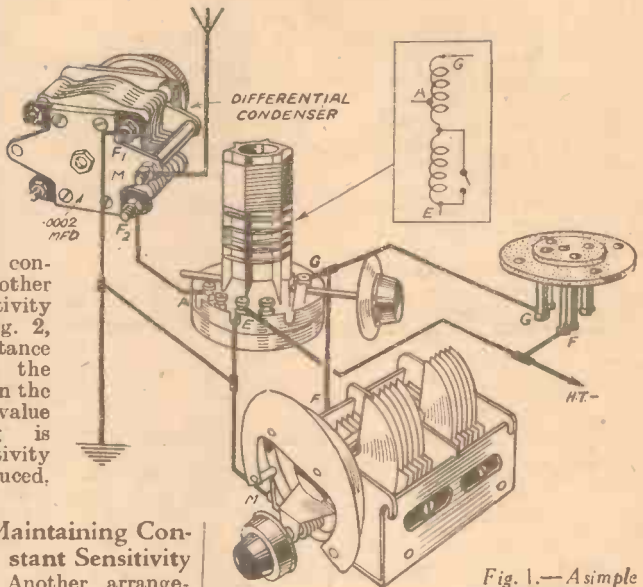

Fig. 1.—A simple and effective method of varying the degree of selectivity—by connecting a differential condenser in the aerial circuit.

a fair amount of experiment, is that shown in Fig. 4, where the differential aerial-input condenser is ganged with the reaction condenser. In this case the condensers are arranged so that the capacity between the vanes marked A and B of the aerial condenser is increased, whilst that between D and E of the reaction condenser is reduced. In other words, the input to the first valve is made greater when the amplification effect of reaction is reduced.

For this scheme to be practicable it is necessary to choose the values of the two condensers with care, and to join them together by means of a coupler which permits of the moving vanes of the two condensers to be meshed to different extents.

(Continued on page 106)

the component itself, access being gained to it only by probing inside the set. The methods of adding easily-controlled variable selectivity to superhets have previously been dealt with in these pages, but there are many readers who use "straight" circuits to which these are not applicable.

Not Really New

It is a fact that many constructors of even the simplest types of "straight" receivers have used some system of controlled selectivity for years without realising it, since it is only recently that the question has been seriously considered. An example of what is referred to is provided by the popular pre-set condenser included in the aerial lead; if this is replaced by a small variable condenser mounted on the front of the set, an excellent variable-selectivity device is at once available. A better arrangement than that of using a plain variable condenser is to employ a differential wired as shown in Fig. 1. The advantage here is that the aerial-earth capacity remains practically constant throughout the range of the condenser, so that tuning is not

as the capacity is increased. The latter is an objection to all of the systems so far considered, and it is not always convenient to have a reduction in sensitivity with increased sharpness of tuning. One method of overcoming this trouble, but one which calls for

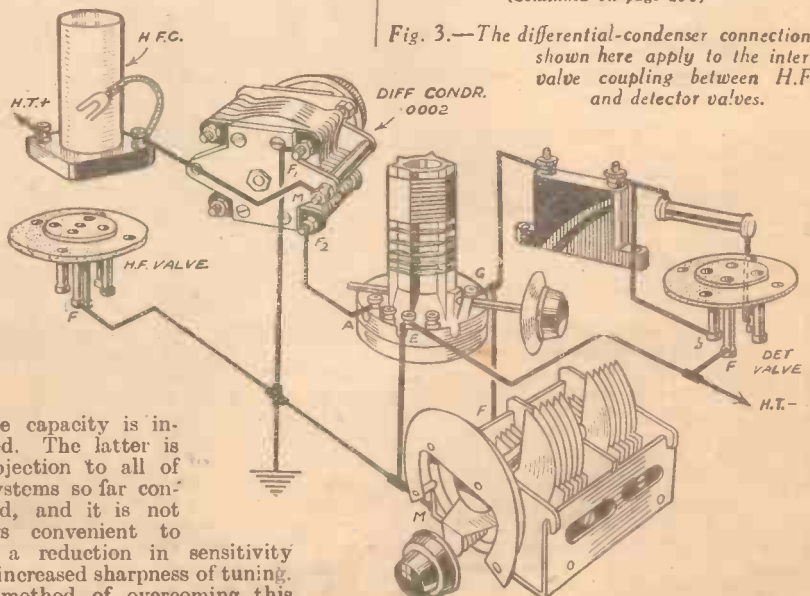

Fig. 3.—The differential-condenser connections shown here apply to the inter-valve coupling between H.F. and detector valves.

Announcing the

LISSEN

Bandspread

SHORT WAVE 3

The most amazing kit ever offered to home constructors! Easy to build—anyone without any previous knowledge of wireless can build it in two hours with the help of a screwdriver and a pair of pliers! Easy to tune—no special skill is required—you can be listening to America or Australia within ten minutes of connecting it up! Never before have so many wireless thrills been brought within your reach for so small an outlay.

HIRE PURCHASE TERMS

On Hire Purchase
Terms: 20/- Deposit
and 10 monthly
rentals of 6/6.

PRICE
69/6
COMPLETE WITH
VALVES

Two hours of engrossing work to build—and the world is at your finger tips! Stations in every distant corner of the world—in America, Australia—stations you could never hope to receive on an ordinary broadcast receiver—are now within your reach with this new Lissen Kit.



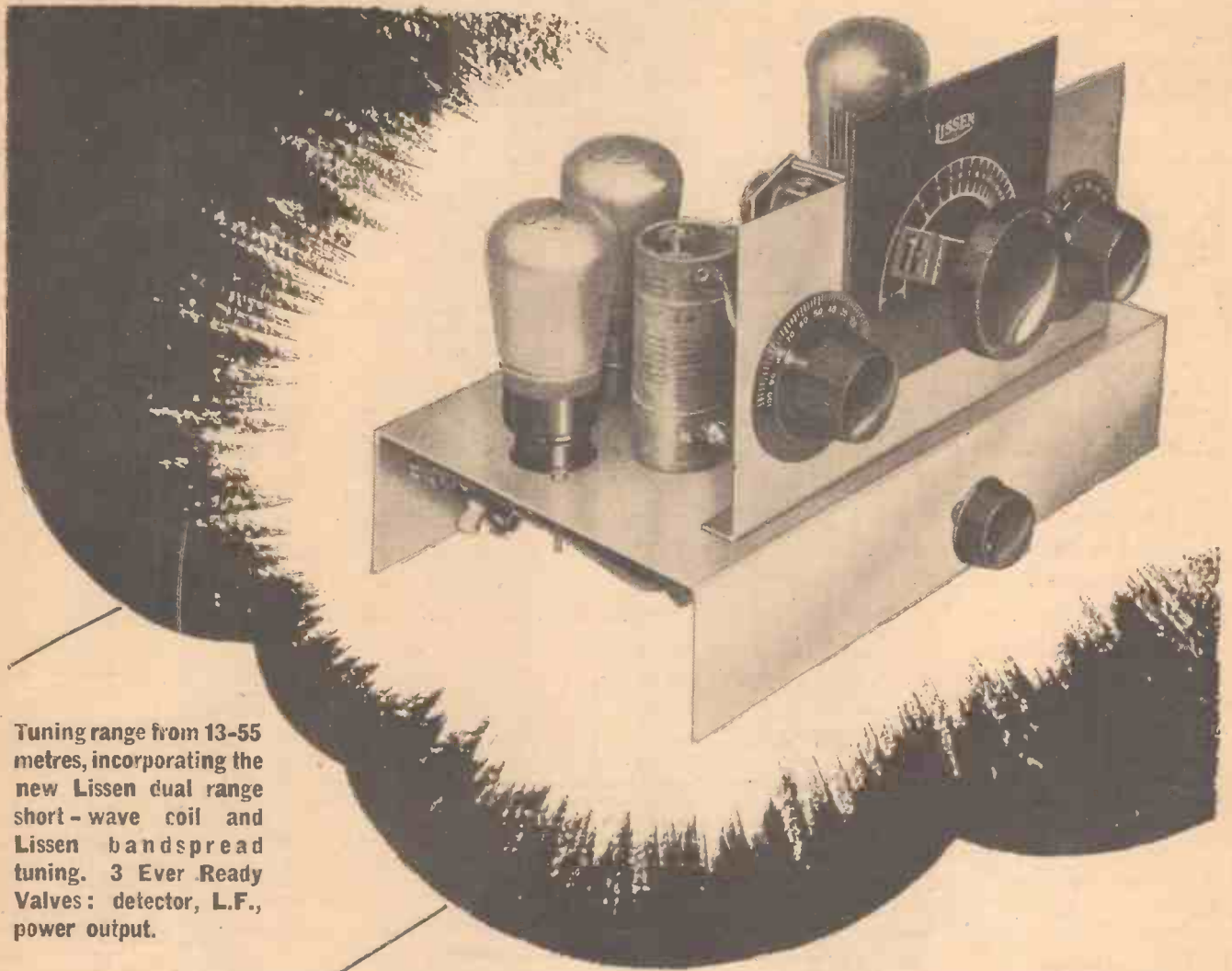

Tuning range from 13-55 metres, incorporating the new Lissen dual range short-wave coil and Lissen bandspread tuning. 3 Ever Ready Valves: detector, L.F., power output.

Get your copy of this wonderful Short Wave magazine to-day!

2 FREE GIFTS
with this issue

Short Wave Time-Zone Map of the World.

Blue-print for the Lissen Bandspread Short Wave 3.



Here's a new magazine for the wireless enthusiast, packed full of really informative articles and illustrations about the most engrossing subject in radio—short waves! And containing full constructional details of the amazing new Lissen kit. Get your copy to-day from any wireless dealer.

COUPON

To Publicity Department, Lissen Ltd., Angel Road, Edmonton, London, N.18.

Please send me

- (a) Copy of Short Wave, Price 3d. including postage.
- (b) Free illustrated lists of the new guaranteed Lissen range of 3 point radio.

NAME.....

ADDRESS.....

Pr.W.

(Continued from page 103)

Thus, the aerial condenser should generally have a value of .0001 to .00015 mfd., the reaction condenser being a .0003-mfd. component. Definite figures cannot be given, however, for they must be found by trial, and vary according to the arrangement of the set and the coils employed.

With Band-pass Coupling

Variable selectivity is most valuable (in a "straight" set) when band-pass coupling is employed, for then a definite band width is

characteristics of the band-pass coils, but assuming that the capacity normally recommended by the makers is .04 mfd., additional condensers of .01, .02, and .05 mfd. should be suitable. When the lower capacities are in circuit the band width is increased, and when the higher capacity is used tuning is made slightly sharper than normal.

When the band-pass coils are intended for use with "top-capacity" coupling, it is a particularly simple matter to provide a variation in selectivity, for it is necessary

inductively coupled it is not generally possible, or wise, to modify the coils themselves so that the coupling winding is movable, but in most cases it is permissible to add "top-capacity" coupling to provide a wider band width for local-station reception.

Those readers who use a simple det.-L.F. or S.G.-det.-L.F. receiver and who feel justified in fitting new coils might consider the use of the Varley Focusing Coils. These are designed to provide variable

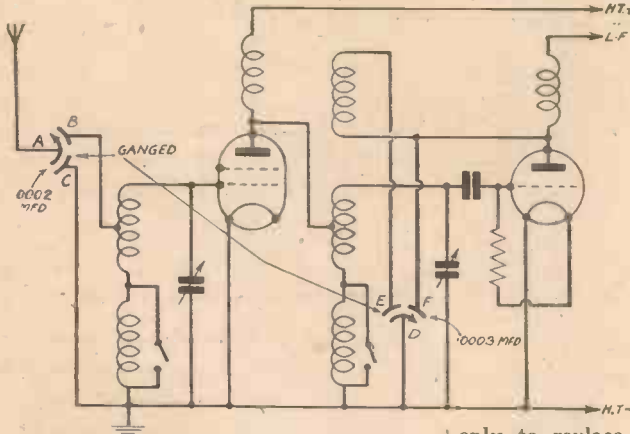
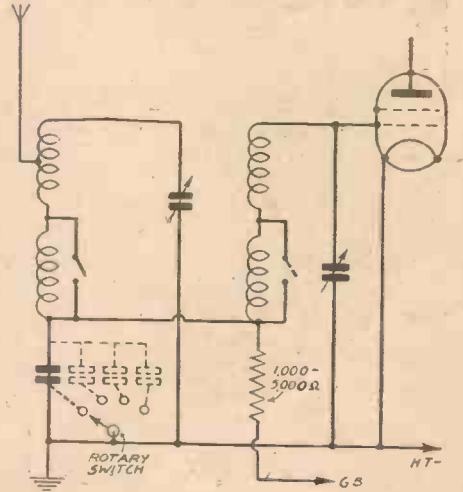

Fig. 4 (left).—So that sensitivity remains reasonably constant when selectivity is varied, the reaction and aerial-input condensers may be ganged as shown here.

Fig. 5 (right).—When a "bottom-capacity" band-pass circuit is used the degree of selectivity can be varied by switching various coupling condensers into circuit as shown in broken lines in this circuit diagram.



covered instead of the tuning curve being "single peaked." When "bottom-capacity" coupling is used as shown in Fig. 5 a reasonable variation in selectivity can be obtained by using three or four coupling condensers, each of which can be brought into circuit as desired. This is shown by broken lines in Fig. 5, where it is assumed that connection to the condensers is made by means of a rotary switch. The values of the condensers will depend upon the

only to replace the fixed coupling condenser by a variable one of suitable value. In most cases an ultra-short-wave variable condenser having a maximum capacity of 35 mmfd. will prove suitable, and should be mounted as close as possible to the coil terminals to which it is connected. When these terminals are not near to the panel it is best to control the condenser through an extension spindle, as is done in the usual U.S.W. receiver.

In the case of band-pass coils which are

selectivity, and the iron core is adjustable by means of a push-pull control; the degree of coupling between the windings is altered by moving the core, and the result is the same as that provided by using a differential condenser in the aerial circuit. Several circuits in which these coils can be used were reproduced in the issue of this journal, dated April 14th, 1934.

MANY listeners are now familiar with the type of chassis which we have specified for all of our receivers during the past year or so, and many have attempted to avoid the use of this type of apparatus by making an ordinary wooden chassis and painting it with aluminium paint, or covering it with a sheet of metal foil. The latter arrangement is satisfactory in certain cases, but the former method is absolutely useless. Firstly, aluminium paint, although composed of particles of the metal, utilises a non-

METAL-SPRAYED CHASSIS AND BASEBOARDS

conducting medium as a vehicle for the paint, and thus, when an object is painted with it, there will be found to be no electrical continuity even over such a small distance as an eighth of an inch. Secondly, the metal-sprayed chassis does not make use of aluminium as many readers imagine, but employs instead ordinary zinc, which is melted, and thus the arrangement follows very closely that used for metallising valves. However, for the benefit of our readers we give here with full details of

the process, which is carried out by means of a special gun patented and manufactured by Messrs. Mellows and Co., Ltd., of Sheffield, and which is known, on this account, as the Mellozong process.

By means of the process it is possible to give a metallic coating to metal, wood, glass, or almost any material.

All metal work is sandblasted before mellozong to remove any rust or scale and to provide a suitable surface to which the metal spray can adhere. With other materials, such as wood, plaster, brick, etc., it is only necessary for the surface to be dry and free from grease.

The metal to be sprayed is first melted in a small, gas-heated crucible, from which the container of the pistol is filled about every twenty minutes. A Bunsen type flame under the container (the gas for which is obtained by connecting the pistol to the ordinary gas mains by means of a rubber hose), keeps the metal in a molten condition whilst spraying. The pistol is also connected by a rubber hose to a compressed air supply of 60-75 lbs. per square inch, and when the molten metal flows to the nozzle it meets the pre-heated compressed air, which very finely atomises it so that minute particles of metal are blown against the surface to be covered at a tremendous velocity, and adhere firmly, forming a continuous metallic coating with a fine matte finish, which is decorative in itself, and an ideal base for paint. The thickness of this coating is approximately .004in., and the speed of application 8 to 10 sq. ft. per minute, but this coating can be increased to any desired thickness.

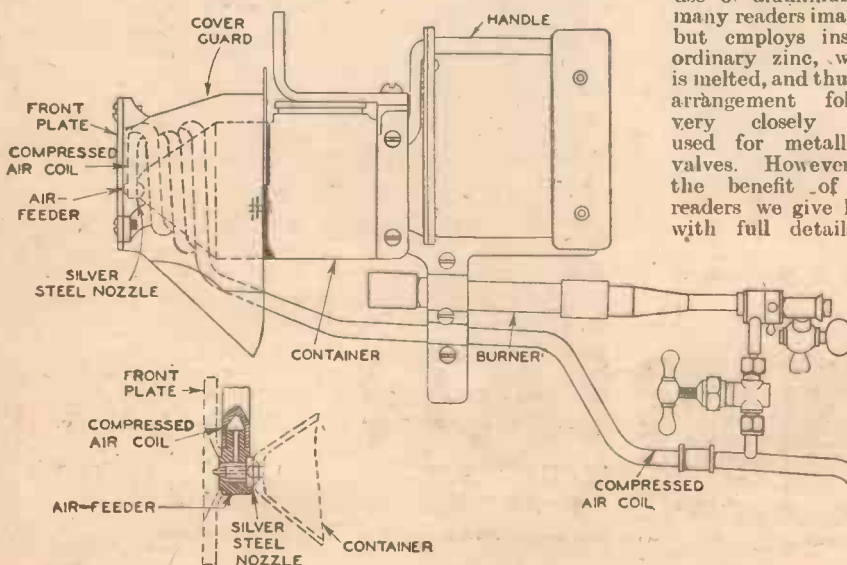

GET THIS IMPROVED REPRODUCTION FROM YOUR SET



VOLUME—20% GREATER

The improved—and larger—"Mansfield" magnet brings a substantially higher sensitivity. The increased loudness not being obtained at the expense of "balance," is comfortably accommodated by the ear. It materially increases the "realism" of the performance.



BASS RESPONSE—FULLER AND 15 C.P.S. LOWER

Measurable bass response goes 15 c.p.s. lower than previous models. Audible response—that part of the bass which is at audible frequency and reaches audible volume—is in these new models much more loudly reproduced. Thus the "bass background" is stronger and more colourful.



HIGH NOTE RESPONSE—900 C.P.S. HIGHER

Due to the stronger magnet, new hand-made cone, and larger section-wound, interleaved transformer, far brighter and cleaner reproduction of high notes and overtones has been achieved this year. This does not imply shrillness—in fact objectional high resonances are conspicuous by their absence.



ATTACK—CLEANER & CRISPER THAN EVER BEFORE

That "forwardness" of tone and the clean, instant response to transients which are so important to realism in reproduction, are, in this new speaker, present to a remarkable degree. Cone material, transformer, and the new accuracy of assembly are chiefly responsible.



**EXCLUSIVELY
SPECIFIED FOR
Mr. F. J. CAMM'S
"1936
SUPERFORMER."**

1936

STENTORIAN

**WHITELEY ELECTRICAL RADIO CO., LTD.,
(Technical Dept.), MANSFIELD, NOTTS.**
Sole Agents in I. F. S., Kelly and Shiel, Ltd., 47, Fleet Street, Dublin.

The simple substitution of this advanced speaker for your present instrument will bring to your radio increased volume and a new amazingly colourful realism.

Ask your dealer to demonstrate to-day, and hear for yourself!

PRICES.

CABINET MODELS	
Senior.. ..	63/-
Junior.. ..	49/6
Baby	29/6
CHASSIS MODELS	
Senior	42/-
Junior	32/6
Baby	23/6
Midget	17/6
Duplex	84/-
EM/W	70/-



Practical and Amateur Wireless

SERVICE DATA SHEET NO. 5

FOR THE BATTERY HALL-MARK FOUR

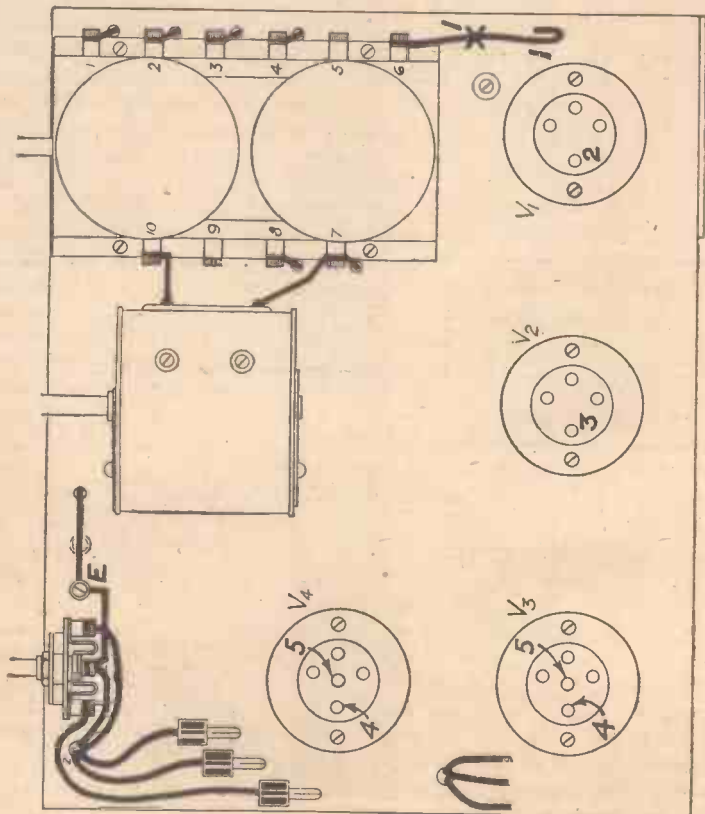

Top of Chassis View

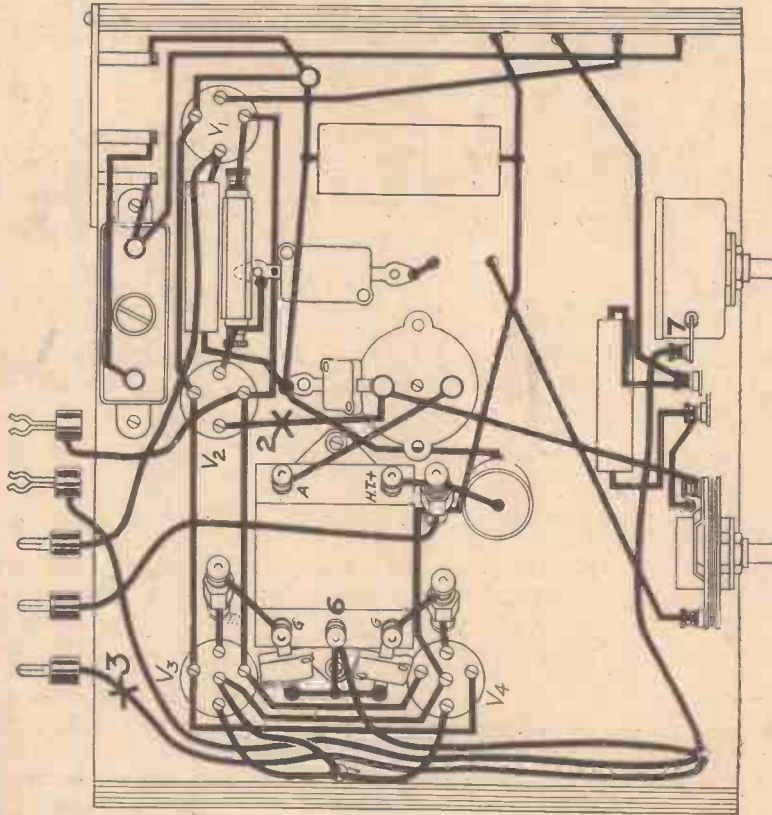

Underside of Chassis

Approximate Voltage Readings	Approximate Resistance Readings	Approximate Current Readings
Voltmeter — to E, 1=120 volts.	Coils with Switch in Medium-wave position.	Milliammeter connected at X1=2 1/4 m.a.
" — to 2=60 volts.	Ohmmeter connected across terminals 4 and 6=1.7 ohms.	" " " X2=1 1/4 m.a.
" — to 3=60 volts.	" " " 1 and 9=1.7 ohms.	" " " X3=13 m.a.
" — to 4=115 volts.	" " " 2 and 3=4.5 ohms.	Coils with Switch in Long-wave position.
" — to 5=120 volts.	" " " 7 and 9=4.5 ohms.	Ohmmeter connected across terminals 4 and 6=10 ohms.
Voltmeter + to E, — to 6=6 volts.	" " " 8 and 9=3 ohms.	" " " 1 and 9=10 ohms.
" — to 7=9 volts.		" " " 2 and 3=23 ohms.
		" " " 7 and 9=23 ohms.
		" " " 8 and 9=3 ohms.

Presenting



F. J. CAMM'S

SUPERFORMER

The Set and the Het of the Season!

By F. J. CAMM

THE Superformer—a super set, a super performer, and a receiver which combines the advantages of the straight and the superhet; four valves, covers short, medium, and long wavebands, whilst the kit of parts costs under Five Pounds. Those are the elements of my latest receiver, expressly designed to suit the needs of some hundreds of readers who require the quality of the straight set on the medium and long wavebands and the great advantages of the superhet on the short wavebands. I believe that this is the first time in the history of home construction that such a circuit arrangement has been produced, and I am confident that it will be built in its thousands. My enthusiasm for it is boundless, for it provides an alternation of programme entirely lacking from the purely broadcast receiver. Interest in short-wave work grows apace, and it will develop to an intense degree in 1936, when the television programme starts. Here is a receiver which provides you with the stepping-stone to the ultra shorts, which enables you to receive programmes from seemingly incredible distances. It introduces no complications in the form of controls, for it will be seen that the number of knobs is the same as for a broadcast receiver. There is no coil changing; there are no doubtful stunts; the circuit is soundly designed, and it works astonishingly well. I do not need to remind readers that every receiver designed by me bears my personal guarantee that it does what I claim for it. I take a keen personal interest in every receiver built from my instructions. My past designs have been well received and have earned for themselves an enviable reputation. The Fury Four, the £5 Superhet, the Silver Souvenir, the All-Pentode Three, the Superset, the Atom Light-weight Portable—these are but a few of the designs which, launched through these pages, have been built in their tens of thousands and are still yielding faithful service.

A Sound Design

The Superformer worthily upholds the best traditions of my previous receivers, and readers are invited to make it, confident that it is free from tricky niceties of adjustment, that it is easy to manipulate, that it is a globe-circler, and that it will bring to you the tongues of the world. I presume that there are still many thousands of people with voracious appetites for foreign programmes. The Superformer provides them in superabundance. It takes you down to that fascinating

waveband between 13 and 90 metres, where you may forget the stereotyped programmes to which you are accustomed and enlarge your listening ambit to fascinating programmes, intriguing conversations, and experiments which will transfix you until the small hours of the morning. You will listen to the free-and-easy conversations of enthusiastic English-speaking amateur transmitters in all parts of the world; recapture the glamour of your early essays in construction, broaden your outlook, and add zest to your listening.

Programmes From the Whole World of Radio

If we are frank with one another, we must admit that listening-in to-day on the broadcast wavebands has been denuded by contemptuous familiarity of its cardinal interests. It has ceased to be the miracle because of repetition. Lack of novelty breeds ennui. With the Superformer you will probably learn for the first time how fascinating listening-in can be. There are hundreds of interesting programmes denied you because of the limitations of the ordinary broadcast receiver. I sometimes feel that we should enjoy radio more were the programmes limited to two per week. As it is, radio resembles the water mains, in that it is ever available and the temptation is to surfeit with too much. If you have reached the stage where programmes bore; if you are unable to listen to the programmes you would like, if jazz is the only programme coincident with the available listening time, the Superformer will take you into realms which for you are as yet uncharted. You will have a receiver which has a magic key to transport you to the normal wavebands; a receiver which will satisfy the family needs; an instrument which opens the doors to a new fascination in radio when the normal bands have closed their portals with their hackneyed "Good night, everybody; good night." I warrant that once you have sampled the unending delights and new experiences which my Superformer makes possible, you will be chained to it in the stilly night ere slumber's chain has bound you. I will speak no more of its renown, but would ask you to have half an hour's chat with me concerning the arrangements which have been employed, and the features which are embodied in the circuit, before passing on to the actual work of construction and test.

Details of the Unique Circuit

It will be evident on first looking at the circuit of the Superformer that the arrangement is particularly unusual

Combined Advantages of Straight & Superhet!

—it is probably unique—for the first valve, which is a pentagrid, is arranged to operate as a normal frequency changer on short waves and as an efficient high-frequency amplifier on the broadcast bands. The change of circuit from straight to superhet is carried out automatically by means of the single wave-change switch, of which more will be written later. The main point is, however, that two sets of contacts on this switch are used to open and close the control-grid circuit of the pentode portion of the first valve and also the grid circuit of the oscillator section. Thus, when the switch is set to give medium- or long-wave reception the first tuning coil is connected to the grid of the first valve and at the same time the oscillator coil is disconnected; changing over to any of the three short-wave ranges has the effect of reversing the operations just described.

H.F. and I.F.

The primary winding of an H.F. transformer is connected in the anode circuit of the first valve, and the tuned secondary winding feeds into the grid circuit of the variable-mu second valve. This connection is the same whether the receiver is functioning as a straight or a superhet, but in the latter case the coil behaves as an intermediate-frequency transformer and is tuned to the highest long wavelength. The detector valve is of the normal leaky-grid type, which has proved to be most satisfactory in this case. The output valve is a high-efficiency pentode, which provides ample output whilst being economical of high-tension current.

Every Worth-while Waveband

Apart from the connections to the first valve, however, the circuit follows well-tried lines and calls for little explanation. By this it is not meant to infer that the remarkable change-over system is untried—on the contrary, it has been very carefully developed and is the result of a considerable amount of experiment. As a

result, I can tell you confidently and without equivocation that the receiver as a whole is particularly efficient when used on any wavelength within the wide range covered. I should say, by the way, that although I do not call the set an all-waver (a term which is frequently used wrongly to describe sets which are quite incapable of use on ultra-short waves), it will, actually, tune to the wavelength of every worth-while station in any part of the world.

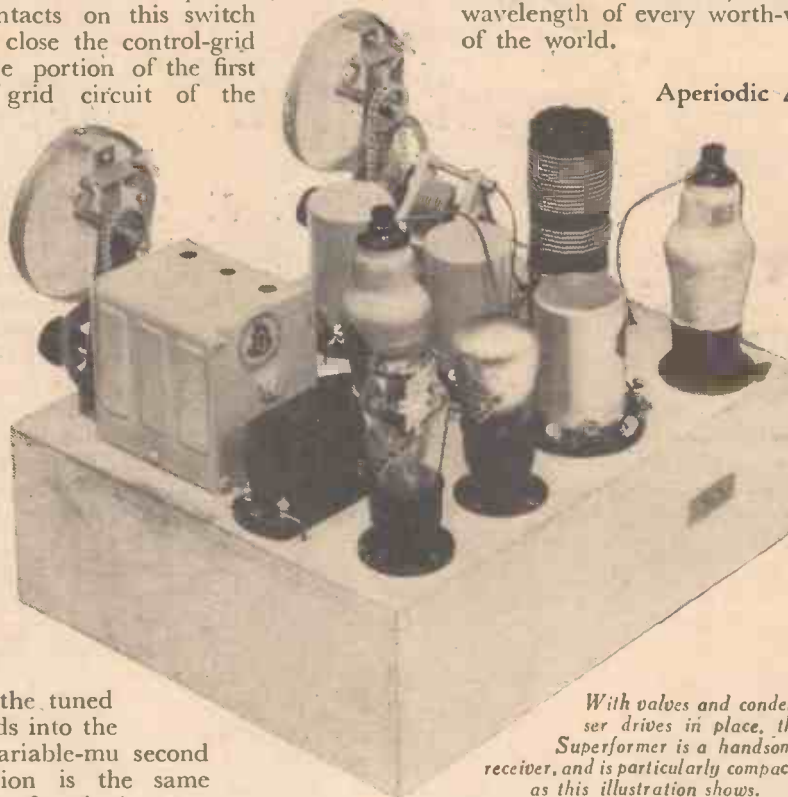

With valves and condenser drives in place, the Superformer is a handsome receiver, and is particularly compact, as this illustration shows.

Aperiodic Aerial Circuit on S.W.

Returning to the circuit arrangement, it is interesting to note that the aerial circuit is made aperiodic when the switch is turned to any of the short-wave positions. This is provided for by the short-wave H.F. choke, which is wired in series with the aerial lead. On broadcast wavelengths the choke has no effect since it offers no appreciable impedance to the signal frequencies. On short waves, on the other hand, its impedance is extremely high, and the necessary signal voltage is thus developed across it.

Separate S.W. Tuning Condenser

A feature which is of especial value is the provision of a separate tuning condenser for use with the short-wave coil unit. This condenser has a capacity of .0002 mfd. and can thus be tuned with extreme accuracy by means of the "Airplane" drive which is attached to it. The short-wave coil is a new type of high efficiency and covers the full range of wavelengths between 13 and 95 metres in three bands, which overlap slightly to ensure easy coverage. In general, it will be found that the majority of stations use wavelengths of approximately 19, 20, 31, and 40 metres, and all of these are covered by the first two positions of the wave-change switch.

Five-way Switching

A note here concerning the operation of the switch

LIST OF COMPONENTS FOR THE SUPERFORMER FOUR

Three Coils, Type BP110 (Varley).
 Three-gang Condenser, .0005 mfd., Baby type (J. B.).
 One S.W. Tuning Condenser, .0002 mfd. (B.T.S.).
 One Differential Reaction Condenser, .00015 mfd. (B.T.S.).
 One S.W. Coil, type S.W.66 (Bulgin).
 Two Airplane Dials (J. B.).
 Three S153 Contact Units, with operating shaft (Bulgin).
 One 50,000 ohms Potentiometer, type VM36 (Bulgin).
 Six Fixed Condensers: one .0005 mfd. (type 665),

C9; two .0001 mfd. (type 665), C7, C10; two .1 mfd. (type 4513), C8 and C12; one .5 mfd. (type 4517), C11 (Dubilier).
 Four Fixed Resistances: two .5 meg (R3, R4), one 100,000 ohms (R2), one 40,000 ohms (R5) (Dubilier).
 One S.W. H.F. Choke, Type HF3 (Bulgin).
 Four Component Brackets (Peto-Scott).
 One L.F. Transformer, 3/1 (B.T.S.).
 One A.E. Terminal strip (Clix).
 Four valveholders: one 7-pin, two 4-pin, one 5-pin (Clix).

Six Plugs: H.T.1, H.T.2, H.T.—, G.B.—, G.B.—1, G.B.—2 (Belling-Lee).
 Two Spades: L.T. +, L.T.— (Belling-Lee).
 Four Valves: 210PG, 210VPT, 210 Det., 220PT (Cossor).
 One Stentorian Senior Speaker (W. B.).
 One Metaplex Chassis, 10in. by 12in., by 3½in. (Peto-Scott).
 One H.T. Battery, 120 volts (Drydex).
 One G.B. Battery, 16½ volts (Drydex).
 One L.T. Accumulator, 2 volts (Exide).

Straight on Broadcast-Superhet on Short Waves!

will not be out of place, although the matter will be dealt with more fully when describing the method of operation. There are three complete sections of the switch, but these are all ganged together so that the complete unit can be considered as being a single component. The knob may be turned to one of five positions, and the first of these adjusts the coils for long-wave reception, the second gives the change to medium waves, the third brings in the first (highest wavelength) section of the short-wave coil, the fourth provides the change to the middle short-wave band, and the fifth makes the set ready for the low-

est range of short waves. The action is somewhat complicated, but this need not worry the constructor in the slightest because the connections are not difficult to make and are all clearly shown on the wiring plan. Those who are chiefly interested in technicalities will find that the system is really ingenious; I can assure you that a good deal of time was taken in working out the full scheme of connections in order to ensure that all the circuits could be controlled from a single point without introducing any form of loss. Remember that it is not possible to use any other type of switch, and that the connections to it should be arranged exactly as shown in the wiring plan and in the various illustrations.

Construction

The constructional work is not at all difficult, although it may appear from the theoretical circuit and the various illustrations that there is a maze of wiring to the various components. Soldering is necessary at various points—especially on the multi-switch, and therefore if you have not yet mastered this part of wireless receiver construction you should make quite certain before commencing the wiring that you can handle the soldering iron. Remember that this is not a difficult task, provided that the essential details are remembered. These are, a clean iron and the correct temperature. If the iron is too hot, or owing to dirtiness it is left for a long time in contact with a soldering tag before the solder runs, then there is a risk of damage and subsequent troubles due to looseness arising from the damaged insulating material. A small tip which is worth bearing in mind in this direction is to obtain some sal ammoniac or a sal ammoniac block and to rub the iron on this when it is withdrawn from the flame. It will remove

scale and dirt and will enable the iron to be tinned much more rapidly, thus facilitating the application of the correct amount of solder at the right spot.

It is worth while drawing attention to the many special solders on the market, and which avoid the possibility of corrosion which would certainly follow the use of spirits of salts. A non-corrosive flux must be used, such as Fluxite, or one of the combined solders and fluxes specially made for wireless.

Use a very soft solder, such as the blowpipe grade, and a small iron, so that there is no risk of burning the non-metallic parts of the components. Make certain that every joint is properly made, and that the solder flows freely. A dry joint will give rise to peculiar and elusive troubles, due to its high resistance, and may be responsible for complete failure.

Merely twisting the wires together may provide a quick method of assembly, and permit rectification of incorrect wiring, as well as a temporary test of the circuit, but when satisfied that the set has been correctly wired, the joints must be soldered for permanent and satisfactory results.

I stress these points because some of the receivers sent to me for adjustment have been carelessly wired, and the defect of which the reader has complained has been traced to this cause.

In one case the wires were left unsoldered, the ends merely being twisted together; these ends had become oxidised, and I was unable to obtain a reading through it. Directly the ends were cleaned and the joint soldered the receiver functioned satisfactorily.

Yet, this set had been (so I was informed) examined by several experts who had given various incorrect reasons for lack of signals.

If I have overstressed this point it is only because I know the trouble lack of attention to apparently insignificant details can give. Attend to the details, and the circuit will look after itself. Follow the specification and the performance will equal the original model which you see in the photographs.

The Chassis

The chassis specified is of the type which is now standardised by us for all of our receivers. It is a plywood structure, the upper surface of which is coated with metal under pressure. Do not attempt to save money by making your own chassis and painting it with aluminium paint. This material is absolutely useless for screening purposes, as it is impossible to obtain continuity

(Continued on page 115)

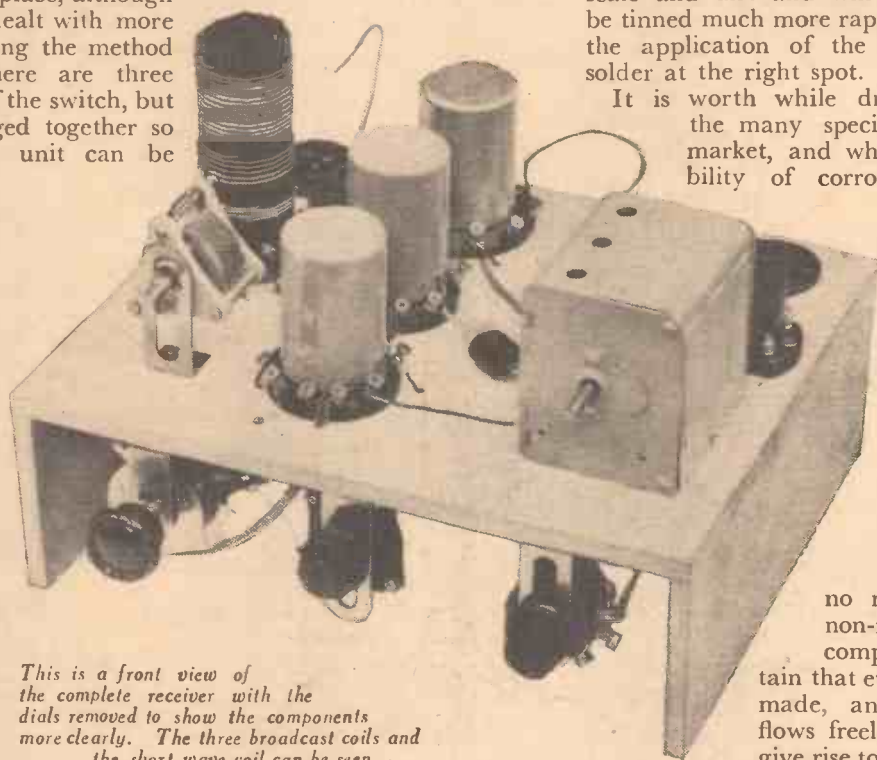

This is a front view of the complete receiver with the dials removed to show the components more clearly. The three broadcast coils and the short-wave coil can be seen.

WIRING DIAGRAM for F.J. CAMM'S SUPERFORMER

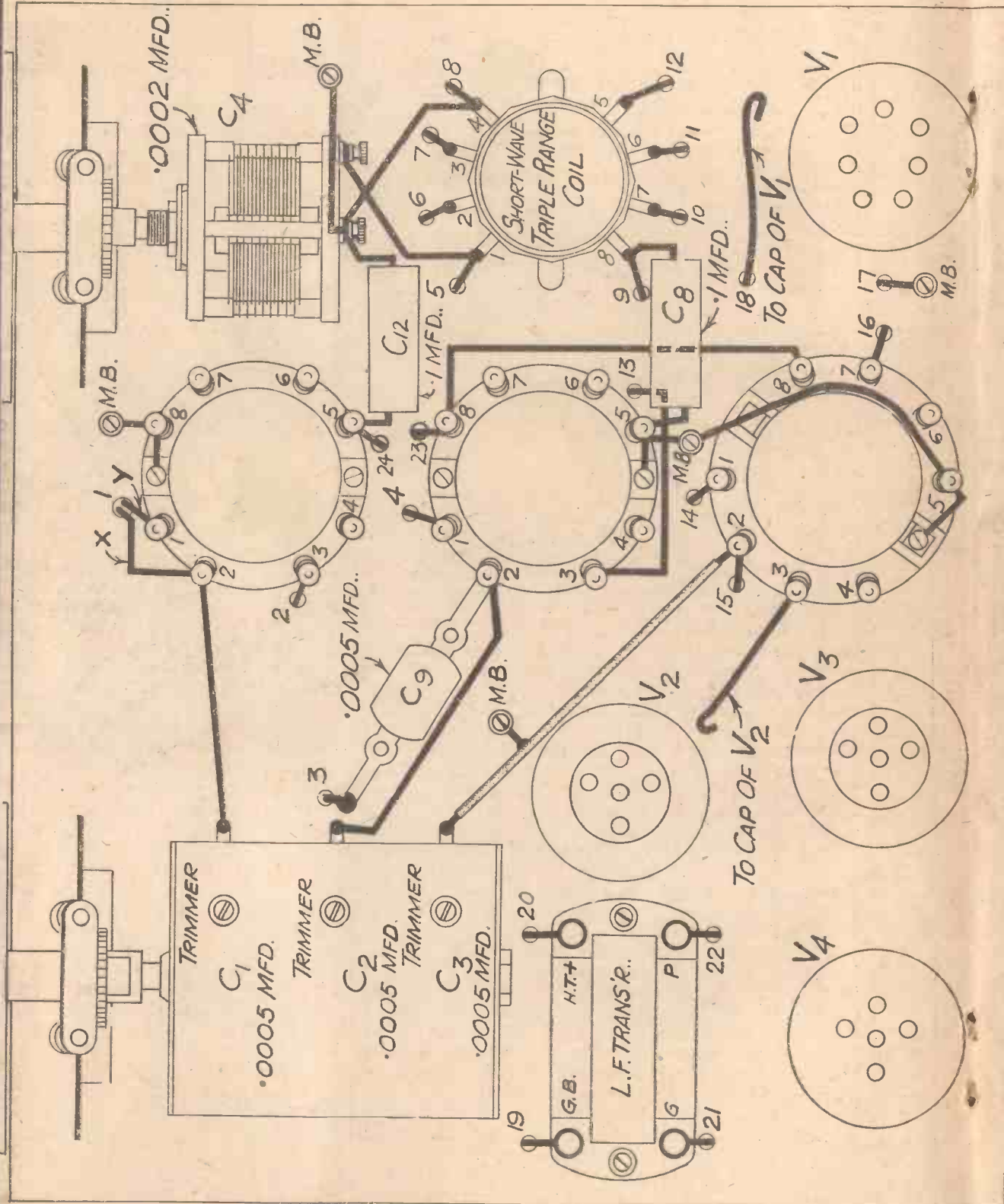

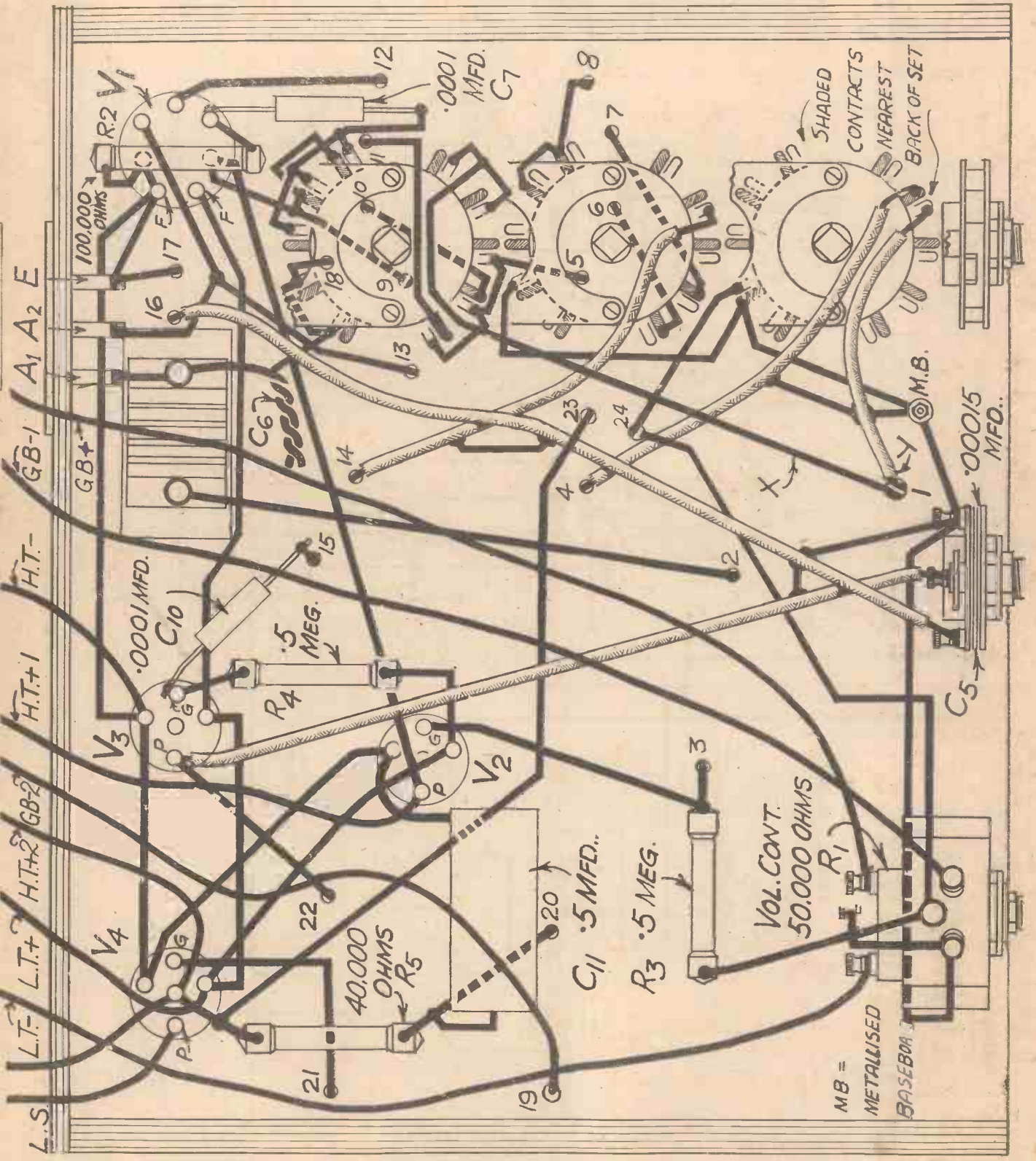

THEORETICAL
CIRCUIT
DIAGRAM OF

"SUPERFORMER"

A Superhet on the Short Waves
A Straight Set on the Medium and
Long Wavebands!

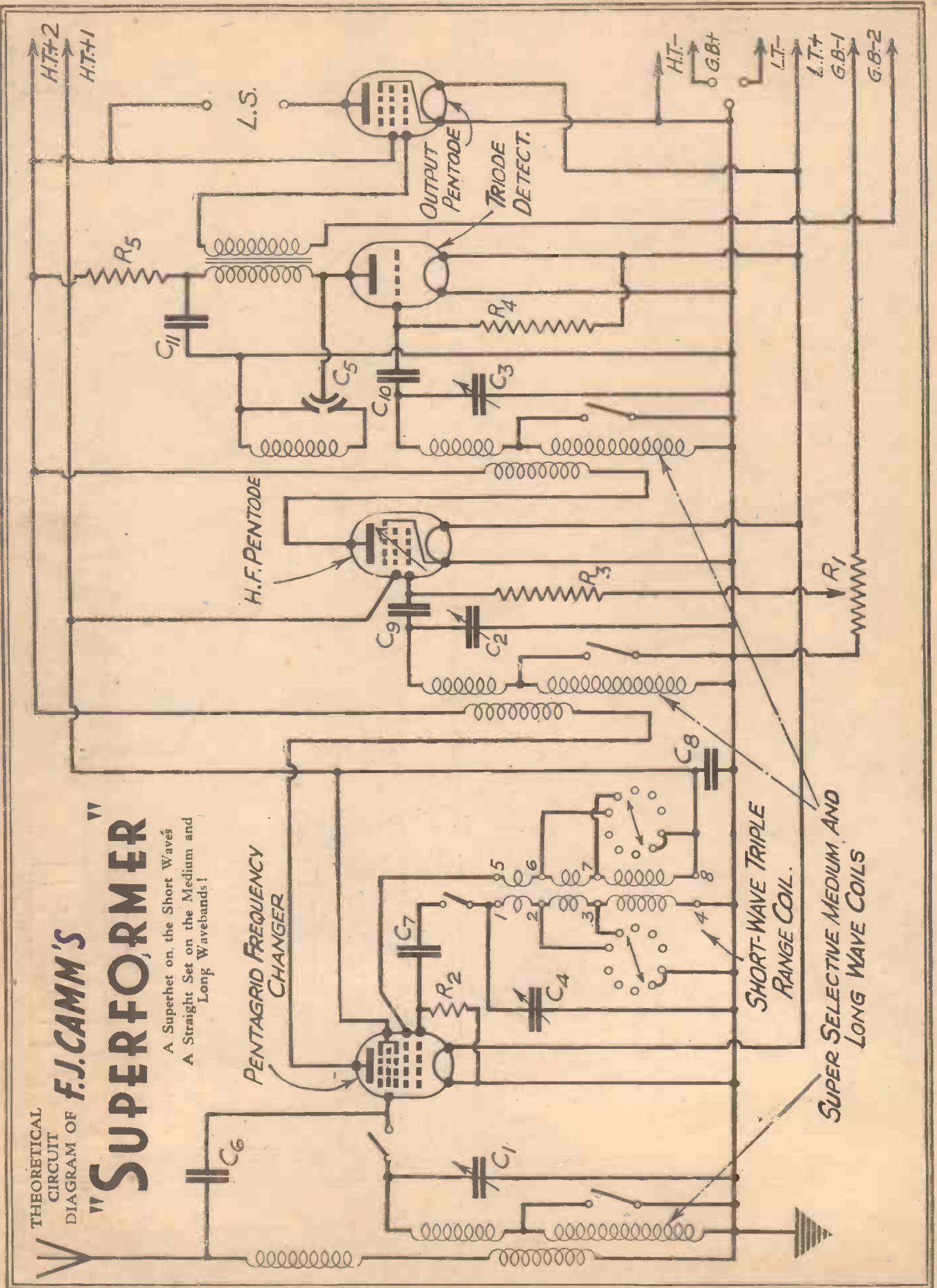

PENTAGRID FREQUENCY
CHANGER

SHORT-WAVE TRIPLE
RANGE COIL.

SUPER SELECTIVE MEDIUM AND
LONG WAVE COILS

H.T.+2
H.T.+1

H.T.-
G.B.+
L.T.-
L.T.+
G.B.-1
G.B.-2

The "Superformer" Selects & Separates

(Continued from page 111)

through it, due to the material in which the metal dust is suspended. If this point is doubted, paint a small piece of wood with the material, and when dry apply a battery (even a 120 volt H.T. battery) to any part of the surface and connect a milliammeter to the other end of the battery and the painted surface. You will find that no current can be revealed and thus the substance does not fulfil the purpose of the metallised chassis. A number of holes are required on the base, and this may be obtained ready cut if desired. If you wish to carry out this part of the constructional work yourself, the holes for the valve-holders should be first drilled, and for the pentagrid valve-holder a hole $1\frac{1}{4}$ in. in diameter is required, whilst for the remaining three valves a hole of $1\frac{1}{8}$ in. will suffice. A number of smaller holes—say $\frac{1}{8}$ in. in diameter—will be required for inter-connecting purposes, and these may be cut at this stage by marking off the positions from the Wiring Diagram reproduced on pages 112 and 113, or they may be drilled as the wiring progresses. If the latter course is to be adopted, it is necessary to make quite certain that the drills which you possess are sufficiently long to enable the operation to be carried out without damaging components nearby.

A hole should be drilled in the rear chassis support in order that the battery cords may be passed through, although in the various illustrations these cords have been omitted for the sake of avoiding confusion. When all holes have been drilled, the panel-brackets, or component-mounting brackets, should be fitted in position, taking the correct point for each from the panel layout reproduced on page 111. It will be noticed from the wiring diagram that these brackets are mounted slightly back from the front edge of the chassis so that when the receiver is placed in the cabinet the fixing nuts will just clear the rear of the panel. A further point to be noted when mounting these brackets is that the screws which are used for the purpose should be of the roundhead No. 4, $\frac{3}{8}$ in. type, and on no account should anything longer be used. This will ensure that contact is not made with the metallised coating on the upper surface of the chassis, with a consequent short circuit to the component mounted on the bracket.

Assembly

Next mount the valve-holders and all of the components with the exception of the multi-switch, omitting also, for the time being, the dials from the tuning condensers. At this stage a certain amount of the wiring may be carried out, principally the filament wiring to each valve-holder, and the connections on the low-frequency side. Alternatively, every part may be placed in position, and the wiring carried out from the theoretical circuit, starting at the aerial and gradually working through the complete circuit. Each constructor has his own preference in this direction, but whatever course is adopted it is essential to keep a very careful check as each wire is placed in position in view of the risk of making a wrong connection, or of omitting a wire.

The Multi-switch

Before the switch can be placed in position it must be assembled, and for this purpose each separate unit of the switch must be placed carefully in the same position. The switch control spindle may be used for this purpose, placing it through the square hole provided and turning the contact arm to one end. Make quite certain that each switch arm is in the same relative position, and thread the three switches on the spindle. Place the locking nut of the spindle through the mounting bracket and lock this, and then space out the three sections of the switch, using as your guide the wiring diagram and the illustrations shown. Each section is held to the baseboard by screws and again the roundhead $\frac{3}{8}$ in. screws will be found most satisfactory. Certain points on the switch are inter-connected, and again, if desired, this part of the work may be carried out before assembly if by this means there is no risk of mistakes arising at a later stage.

Wiring

The actual connection between the various parts may best be carried out by the special insulated wire sold for the purpose, and which is fairly thick and gives a neat appearance to the finished receiver. Scrape away the insulating material for a distance of $\frac{3}{8}$ in. at each end, and make a small loop by means of round-nosed pliers for attachment to terminals, and leave only about $\frac{1}{8}$ in. bare for those points which have to be soldered. Although a sharp penknife will be found useful for removing this insulation, care must be taken not to cut deeply into the wire, or there may be a breakdown at some later date due to the loop or soldered end breaking off. When a wire is placed in position the corresponding wire on the wiring diagram should preferably be marked through in coloured pencil

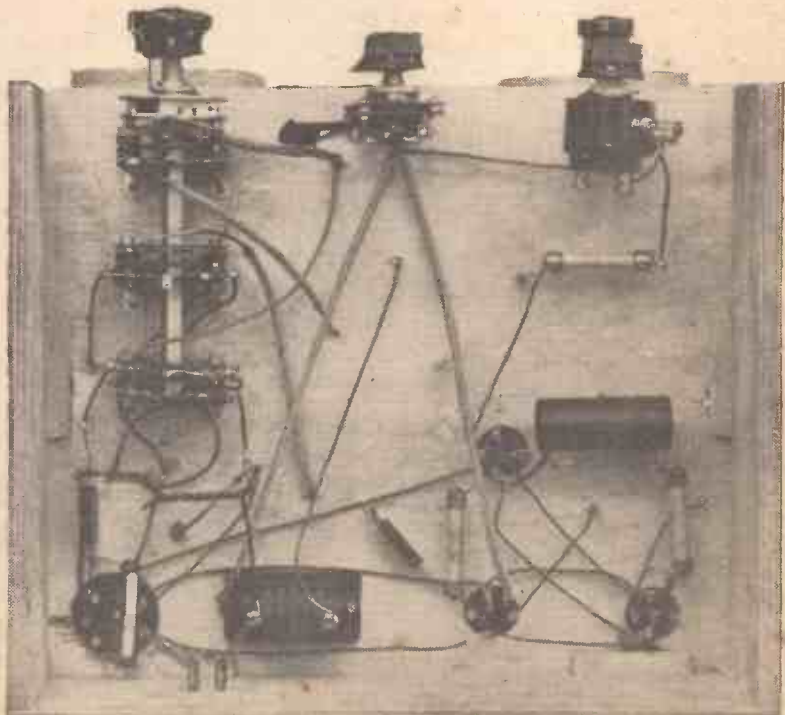

This illustration shows the under-chassis wiring of the Superformer and, in particular, the wiring of the five-way change-over switch, which comprises three separate ranged units

Super Simple Switching!

or in ink so that subsequent wires are more easily identified. This also provides a simple check upon each connection and avoids the risk of wrong connections or left out wires.

Testing

When the wiring is completed the circuit may be checked from one point to another by means of a battery and meter, or the valves may be plugged in and the set tested on an aerial. The provision of a fuse in the H.T. lead will avoid the risk of damage to the valves due to a short-circuit in this part of the receiver, although a voltmeter may be used to test the voltage at the filament terminals before the valves are inserted, but after the set is switched on. If everything is found in order the aerial and earth may be connected, and the switch set to the medium-wave position. The reaction condenser should be set to zero (maximum rotation anti-clockwise) and the volume control should be set to about its mid-way position. Rotation of the right-hand condenser assembly should result in the local station soon being heard, and the strength of the signal should be smoothly controlled by the combined volume-control and on-off switch. Perfect stability should result even at the position of maximum volume, and in the case of weak stations the reaction control should function in a smooth manner. The movement of the switch from one position to another will enable the wave-range to be changed, and at the same time it will modify the circuit according to the range which is in use.

When the switch is at its maximum clockwise setting the circuits will be tuned to the long-wave band of approximately 900 metres to 2,000 metres. Rotating the switch knob in an anti-clockwise direction, the next position tunes in the medium-wave band of approxi-

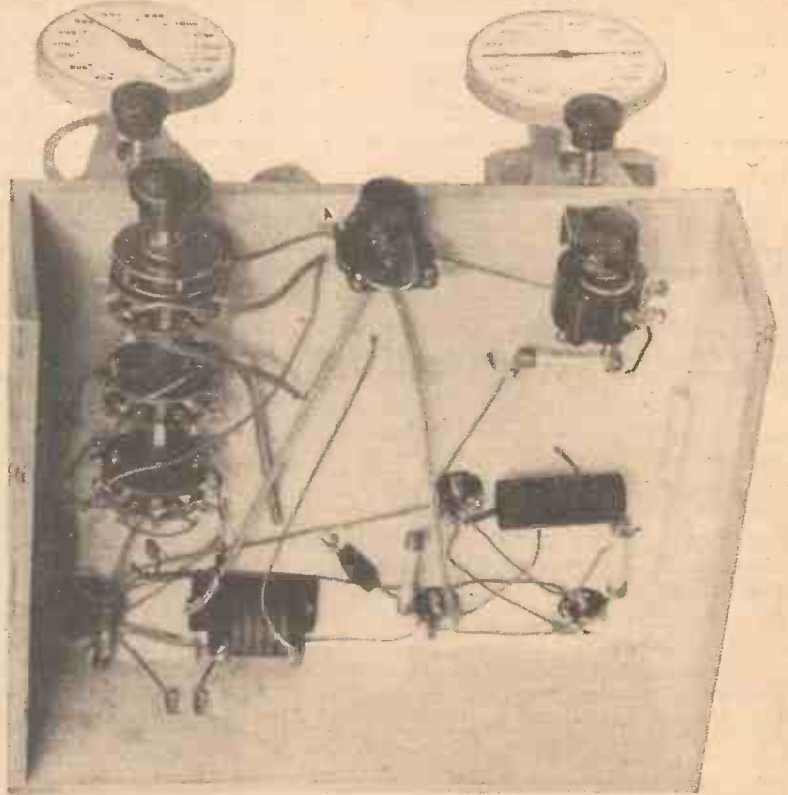

A three-quarter underneath view of the complete chassis, showing the symmetrical disposition of the controls and the handsome condenser drives.

mately 200 to 550 metres. The last three stops will give the short-wave bands of approximately 50 to 90 metres, 23 to 55 metres, and 13 to 25 metres respectively. It is emphasised that these wavelength figures are approximate, as the actual wavelength is governed to a great extent by the stray capacities in the circuit; this is particularly so on the short-wave bands.

Tuning

When the receiver is tuned to medium and long waves it functions as a straight H.F. set, and the volume control and reaction condenser must be used in the normal manner. As soon as the wave-switch is set for short-wave reception, however, the receiver is automatically converted into a superheterodyne. Tuning is then effected by means of the short-wave tuning condenser, operated by means of the left-hand tuning drive, the medium/long-wave drive on the right-hand side of the chassis being rotated to approximately maximum setting. The best setting is found by experiment, however, it being essential to tune to a position where no long-wave stations can be heard.

To obtain maximum results on the short waves, the three-gang condenser must be accurately trimmed so that each of the three tuned circuits are adjusted to the same resonant point.

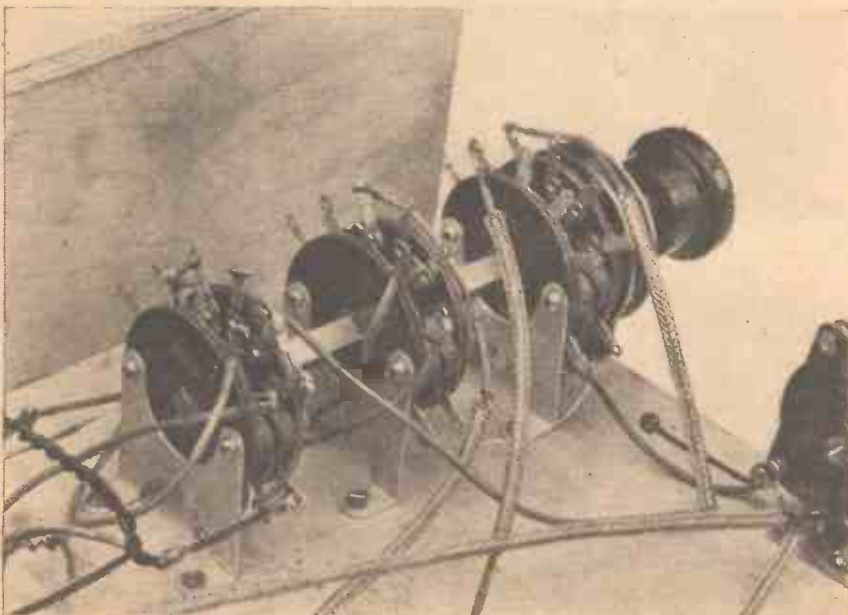

A detail view of the multiple switch. It performs seven different operations although calling for the use of only a single central knob.

Noise-free Aerial Systems-3

Further Particulars Concerning this Important Subject are Given in This Article By G. V. COLLE

BEFORE we proceed to delve into the technicalities of true all-wave aerial systems, it is desirable that a little further information be given on the merits of the matched transmission line arrangement described in the first article. It was stated that the downlead consisted of a small diameter screened conductor of 50 to 400ft. in length, and arranged with step-down and step-up impedance matching units at the aerial and receiving ends respectively, for medium- and long-wave reception. Some makers arrange for 200 to 2,000 metre coverage, while others provide down to 75 metres by slight adjustments on the receiver impedance matching unit.

The list of noise-proof aerials given at the end of this article discloses an interesting position, namely, only one true all-wave system. In terms of American wavebands those shown under "medium and short waves" are all-wave arrangements, but this is not correct when considering European transmissions, which extend up to 2,000 metres. "Telestat" is primarily arranged for short waves, but will operate on medium and long waves by substituting suitable receiver coupling units.

Circuit Schemes

A careful examination of the various circuit schemes employed for these noise-proof aerials has shown that those systems making use of twisted feeder cables are

applicable for all-wave results, provided that suitable units are fitted at the receiver end. In other words, systems covering short, or short and medium waves, can be made to function effectively on the long waveband (900-2,000 metres). Aerials employing small diameter screened downleads will not function on the short waves, as the capacity losses due to the screening cannot be overcome.

The fundamental theoretical consideration of the all-wave aerial, and of those intended for medium and short waves are very similar. Close inspection of the schemes yields the information that the horizontal aerial portions are arranged and adjusted to suit the short wavebands, generally at a mean receiving frequency. Whereas in Fig. 1 the makers have contented themselves with doublet or dipole aerials, in Fig. 2, the aerials have been duplicated as double-doublets. Both aerial schemes operate as half-wave collectors of short-wave signals, and in this respect their efficiency is high, especially at their natural (wavelength) resonance point.

By combining, as in Fig. 2, two dissimilar doublets, on the assumption that the performance of each one is not impaired by the other, the over-all performance of the combination should be improved over a wider range of wavelengths. Whether the increase in efficiency justifies the greater aerial complications has not yet

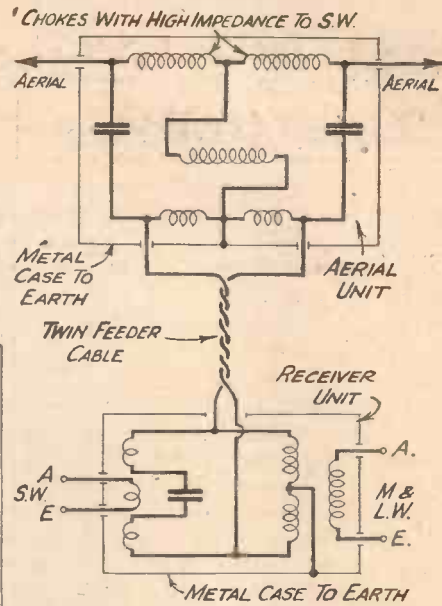

Fig. 1.—A comprehensive arrangement which is incorporated in a commercial impedance-matching scheme.

been confirmed by accurate laboratory tests.

All-wave System

Reverting to the all-wave system (Fig. 1), the aerial unit comprises a matching step-down transformer, a pair of short-wave H.F. chokes, and by-pass condenser housed under one metal cover. Short-wave signals received on the doublet aerials are restricted from passing to the step-down transformer by the chokes and consequently take the easier paths offered by the condensers direct to the feeder cable. Medium- and long-wave signals pass through the chokes, and thence through the primary of the transformer to earth, thereby setting up equal and opposite signal currents in the secondary. These 180 degree out-of-phase currents are transferred to the receiver transformer by means of the low-impedance feeder cable (about 150-180 ohms), and combine again in the latter to set up signals in the output winding joined to the "A" and "E" terminals on the set. Noise voltages picked up on the unscreened-feeder cable are induced equally into both wires, but since they represent in-phase signals, whereas true signal currents are out-of-phase, the latter only can be passed on to the receiver. At least, that is the technical explanation, and it is borne out in practice provided no capacity effects exist between the receiver transformer windings. An earthed electrostatic metal foil screen interposed between the windings, as mentioned in the first article, prevents the undesired effect.

Short-wave signals are passed down the feeder cable in exactly the same manner as described, and pass to the S.W. output owing to the blocking effect of the broadcast-wave transformer, which is purposely constructed with a high inductance (a condenser in circuit with the S.W. primary prevents the reverse effect). It would be difficult to imagine a more ingenious method of combining the features of several aerials in one system. Even allowing for losses, which are not inconsiderable, the efficiency is sufficient satisfactorily to operate an all-wave superhet of five or more valves.

When it happens through lack of space doublet aerials cannot be erected to their

(Continued overleaf)

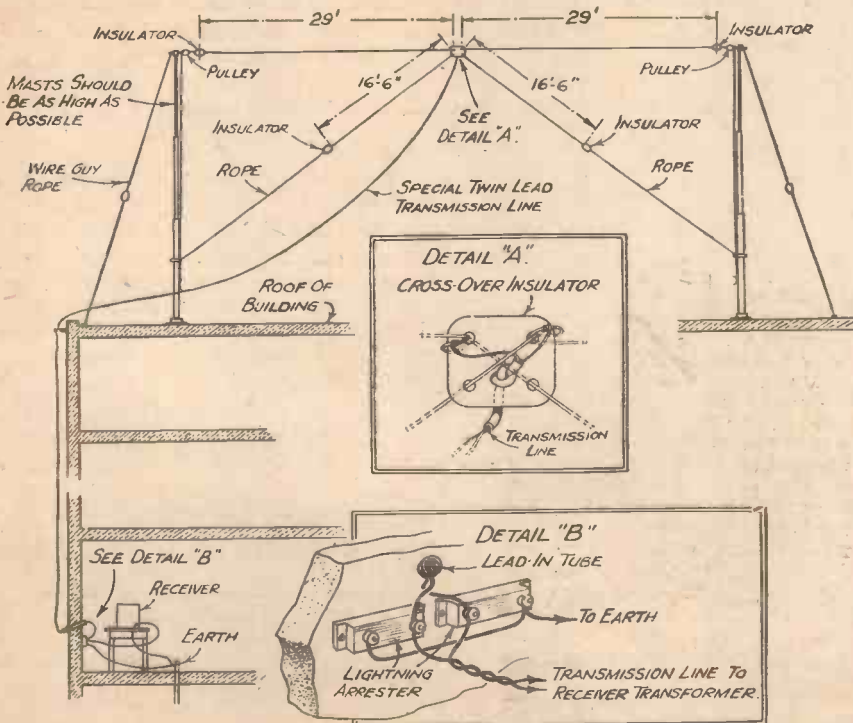

Fig. 2.—Full constructional details of an American aerial system which is referred to in the text.

Let Us Send You This 40-Page Booklet—Free



It gives full information regarding various I.C.S. Courses of Instruction in Radio work.

The Radio industry is progressing with amazing rapidity. Only by knowing thoroughly the basic principles can pace be kept with it. I.C.S. Instruction includes American broadcasting as well as British wireless practice. It is a modern education, covering every department of the industry.

OUR COURSES

Included in the I.C.S. range are Courses dealing with the Installing of radio sets and, in particular, with their Servicing, which to-day intimately concerns every wireless dealer and his employees. The Equipment Course gives sound instruction in radio principles and practice.

There is also a Course for the Wireless Salesman. This, in addition to inculcating the art of salesmanship, provides that knowledge which enables the salesman to hold his own with the most technical of his customers.

Then there are the Preparatory Courses for the City and Guilds and I.W.T. Exams.

We will be pleased to send you details and free advice on any or all of these subjects. Just fill in, and post the coupon, or write in any other way.

International Correspondence Schools, Ltd.,
Dept. 94, International Buildings,
Kingsway, London, W.C.2.

Without cost, or obligation, please send me your "Radio" booklet of information about the Courses I have marked X

- COMPLETE RADIO
- RADIO SERVICING
- RADIO EQUIPMENT
- RADIO SERVICING AND SALESMANSHIP
- WIRELESS ENGINEERING
- EXAMINATION (state which)

Name..... Age.....

Address

(Continued from previous page)

specified lengths end to end, one section can be turned at an angle to the other, but not to a greater extent than 45 degrees. Should this also be impracticable, the aerials may be tilted to form a V in a vertical direction. A further alternative is to maintain both aërials end to end, cut down their lengths equally, and load each with small coils at their inner ends, as shown in Fig. 3.

Important Pointers

Several technicians have recently acquainted the writer with their experiences and, as is usual in these instances, considerable information has been gleaned and facts deduced from the ensuing discussions. Here are some of the points, as related:—

(1) It was generally agreed that an all-wave aerial is based on the short-wave version, that is, the latter wavebands required the greatest consideration in the design.

(2) Twisted twin "feeders" in conjunction with dipole aerials provide a larger signal to noise ratio than parallel-wire feeders, the latter, however, having the greater signal efficiency.

Apparently the twisted feeder does not act as collector of energy, and is, therefore, more likely to exclude electrical static. For the same reason the signal pick-up would be less, not an undesirable fact in the circumstances.

(3) Dipole aerials with various un-screened but reputed noise-proof downleads functioned well on medium and long waves, often without special receiver-coupling units.

(4) Similar aerials intended for short waves only also acted efficiently on the broadcast wavebands but sometimes comparatively poorly as regards noise suppression and signal on short-waves! It transpired that steps were not always taken to prevent direct noise pick-up in the set itself. In areas of high noise level, and for that matter in most districts, interference which was unobtrusive on broadcast waves became intolerable on the short wavebands. Consequently, it was often found necessary to elaborate on noise suppression equipment by providing short-wave mains chokes and very complete screening in the receiver. Open bottom metal chassis and screened coils were quite inadequate and no proof against direct S.W. static pick-up if, for instance, grid leads or wires in any of the tuned circuits were exposed. As the separate screening of such leads would be a tedious business and lead to H.F. losses, complete receiver screening was the only solution.

In effect, a noise-proof aerial system of the all-wave or short-wave type could not be considered to be fairly tested until it was proved to be the *only* means of reception. If electrical static then persisted on short waves, but not on the usual broadcast bands, it would indicate that the downlead was not entirely noiseproof, or that part of the static was received on the horizontal aerials. The twin aerial feeder cable does not always call for an earth lead, but in those cases where it is essential, the importance of a short lead and one of low ohmic resistance was stressed.

One technical fact which did not emerge in these discussions does much to explain why an all-wave aerial cannot be expected to provide the maximum short-wave signal strength. These aerials, with their receiver

matching transformers, are untuned and hence must possess fixed lengths for the horizontal sections. While this latter detail is unimportant on medium and long waves owing to the natural aerial frequency being well below the reception frequency, yet on the short waveband a point must inevitably be reached where resonance occurs. On other short wavelengths off resonance the signal strength drops and consequently, judged against a tuned feeder downlead with an aerial for short waves only, the results with respect to volume compare unfavourably. Tuned feeders, by the way, provide uniform signal reception, but cannot, for numerous reasons, be incorporated with commercial aerial designs.

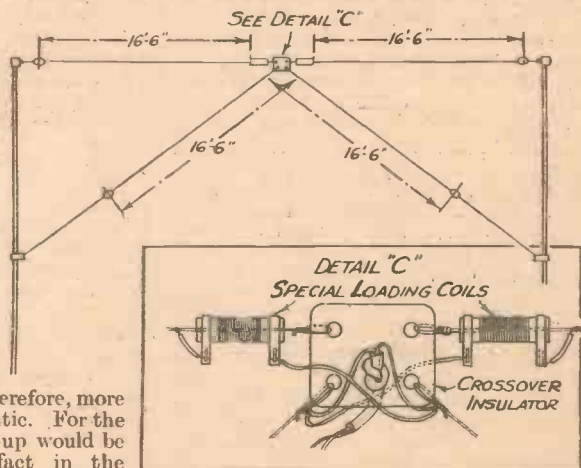

Fig. 3.—An arrangement which may be adopted where space is restricted.

Systems Available

The position with regard to the supply of noise-proof aerial systems is as follows:—
All-wave types

The H.F. All-wave Radio Antenna of the Technical Appliance Corporation of New York, which is obtainable from R. A. Rothermel, Ltd., Rothermel House, Canterbury Road, Kilburn, London, N.W.6.

Medium and long-wave types (200-2,000 metres)

"Rejectostatic," made by Kolster-Brandes, Ltd., Cray Works, Sidcup, Kent. Supplied under licence by Belling & Lee, Ltd. "Statoformer,"—Ward & Goldstone, Ltd., Pendleton, Manchester. Licensed under English patents of Amy, Aceves & King, U.S.A. (75 to 2,000 metres). E.M.I. Anti-static Aerial Equipment—Electrical & Musical Industries Service Ltd., Hayes, Middlesex.

75 to 600 metre types
Radioformer, Ltd., 31, Feldway Road, London, S.E.13. "Statoformer"—Ward & Goldstone, Ltd. (see above).

Medium and short-wave types
Double doublet and "all-wave" (same system).

General Electric U.S.A.
R.C.A. U.S.A.

Short-wave types
"Crossfeeder"—Stratton & Co., Bromsgrove Street, Birmingham, 5. "Telestat"—Ward & Goldstone, Ltd., Pendleton, Manchester.

TO FIND THAT FAULT, READ—
EVERYMAN'S WIRELESS BOOK
By F. J. CAMM,
now only 3/6, or 3/10 by post from
George Newnes, Ltd., 8-11, Southampton Street,
Strand, W.C.2.

Short-Wave Notes

Jeløy

During the past few days I have had many enquiries relating to a station which, although not thought to be German, has puzzled listeners. It is, as a matter of fact, LKJ1, Jeløy, on 31.34 metres (9,572 kc/s), which relays the Oslo programmes. It is on the air from roughly G.M.T. 16.00 daily until the capital station closes down; on Sundays it may be heard working in the morning. There should be no difficulty in identifying this broadcast as you hear the Oslo call, and the same interval signal is used. It is simply because the channel adopted is very close to that of DJA, Zeesen, that the confusion arises.

Finally, in the amateur band, I learn from a correspondent that we may now pick up a station at Kingston (Jamaica). It is VP5MK on 42.74 metres (7,020 kc/s), which every Saturday puts out a special talk on Jamaica between G.M.T. 22.00-22.30.

Japanese Relays

For the winter months, the Japanese are carrying out the short-wave relays of the JOAK, Tokio, programmes through JVH, 20.55 metres (14,600 kc/s), JVN, 28.14 metres (10,660 kc/s) and JVP, 39.95 metres (7,510 kc/s). A special programme destined to Europe is broadcast every Wednesday and Friday between G.M.T. 19.00-20.00. For those who desire veris of their reception, write to Kokusai Denwa Kaisha, Limited, No. 3 1-Chome, Uchisaiwaicho, Kojimachiku, Tokio, Japan. As these are 20-kilowatt transmitters, the logging of their signals should not be difficult.

According to a recent report the Winnipeg (Manitoba) stations CJRO and CJRX on, respectively, 48.83 metres (6,114 kc/s) and 25.6 metres (11,715 kc/s) are extending their activities and, in addition to their usual transmissions, may be heard relaying our Empire broadcasts as well as other foreign programmes. The station opens with a record: "O Canada," and closes down with "God Save the King." CJRX will be found just above the French Pontoise State transmitter.

Venezuela

YV3RC, Caracas, on 48.78 metres (6,150 kc/s), undoubtedly one of the most progressive of the Venezuelans, is already advertising its winter schedule. Transmissions are made daily from G.M.T. 15.30-18.30 and again from 20.30-02.30. The announcer gives out the call in both Spanish and English. Should you hear the former, it is: *Radiodifusora Venezolana*, followed by the call sign (YV3RC) sounding as *Yay ray trays erray say en Caracas*. The interval signal consists of four notes on gongs, and as a general rule the station opens up with a fanfare of trumpets followed by a peal of bells. I understand that it may also use an alternative channel, namely, 31.54 metres (9,510 kc/s).

Another South American, HJ4ABE, Medellin (Colombia) on 50.59 metres (5,930 kc/s) has now increased its power to 4 kilowatts, and in consequence, notwithstanding its distance from London, roughly 4,650 miles, is frequently heard in the British Isles—between G.M.T. 00.00-04.00. Here again, four strokes on a gong are used to denote intervals and, as a general call, the studio styles itself *La Voz* (The Voice) de Antioquia.

PETO-SCOTT PILOT AUTHOR KITS

Exact to Specification

IMMEDIATE DELIVERY

of all makes of Speakers, Eliminators, Kits, Pick-ups, Testing Meters, Receivers for CASH, C.O.D. or H.P. PILOT AUTHOR KITS are only obtainable direct from Peto-Scott. We can supply any Kit featured in this journal during the past 3 years.

Peto-Scott HIGH FIDELITY PERMANENT MAGNET SPEAKERS

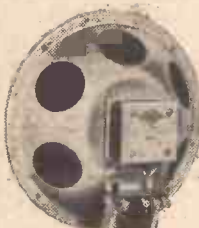

TYPE NEW BABY. For Power, Super Power or Pentode. Complete with input transformer. Cash or C.O.D. Carriage Paid, 15/6, or 2/6 down and 6 monthly payments of 2/6.

TYPE S.1. For Power, Super Power or Pentode. 8" chassis with input transformer. Cash or C.O.D. Carriage Paid, 19/6, or 2/6 down and 8 monthly payments of 2/6.

TYPE S.3. DE LUXE (illustrated). For Power, Super Power, Pentode, Class "B" and Q.P.P. 9" chassis with input transformer and oversize cone. Cash or C.O.D. Carriage Paid, 32/6, or 2/6 down and 11 monthly payments of 3/-.



1936 STENTORIAN SENIOR

Type 36S. Cash or C.O.D. Carriage Paid, £2/2/0, or 2/6 down and 11 monthly payments of 4/-.

2/6 DOWN

W.B. STENTORIAN JUNIOR

MODEL 36J. Suitable for any output and incorporating improved Microloade device. Cash or C.O.D. Carriage Paid, £1/12/6, or yours for 2/6 down, balance in 11 monthly payments of 3/-.

W.B. STENTORIAN BABY MODEL 36B. £1/3/6, or 2/6 down and 10 monthly payments of 2/6.

NEW DISCOVERER H.F.P.3.

Peto-Scott's Amazing Short-Waver.

AMERICA DIRECT!

13-96 METRES, with a 12,000-mile tuning range. This wonderful Peto-Scott Short-waver will enable YOU to know the thrill of programme reception from every corner of the world.

Built in one evening with simple tools.

KIT "A"

Comprises all necessary parts to build, with 6 coils (13-96 metres) less valves and cabinet. With Full Size Blueprint and detailed instructions. Cash or C.O.D. Carriage Paid, £4/5/0, or 5/- deposit and 12 monthly payments of 83.

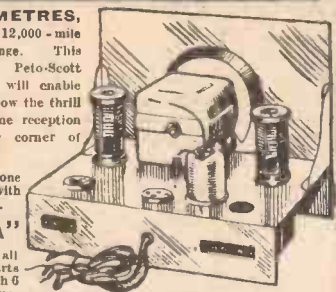

5/- DOWN

FINISHED INSTRUMENT Individually tested on American S.W. stations. Complete with Valves and Walnut veneered Cabinet, less Batteries. Cash or C.O.D. Carriage Paid, £8/0/0, or 10/- down and 12 monthly payments of 14/-.

SEND FOR FULL PARTICULARS.

1936 Peto-Scott ELIMINATORS 1936

ILLUSTRATED CATALOGUE ON REQUEST.

5/- DOWN

MODEL M.A.10/30 with 2v. Trickle charger. Output 30 m/A at 150 volts. A.C. mains 200/250 volts. Cash or C.O.D. Carriage Paid, £2/19/6, or 5/- down and 11 monthly payments of 5/6.

MODEL A.C.12 (illustrated). Output 120 volts at 12 m/A. Cash or C.O.D. Carriage Paid, £1/10/0 or 2/6 down and 10 monthly payments of 3/-.

MODEL A.C.25. Cash or C.O.D. Carriage Paid, £2/9/6, or 5/- down and 10 monthly payments of 5/-.



SUPERFORMER KIT "A"

CASH OR C.O.D. £4:17:6 Carriage Paid.

Or 7/6 deposit and 11 monthly payments of 9/-.

Author's Kit of First Specified parts, including ready-drilled METAPLEX Chassis and Brackets, less valves, cabinet and speaker.

KIT "B" As for "A," but with set of specified Valves. Cash or C.O.D. Carriage Paid, £7/8/6, or 12 monthly payments of 13/6.

KIT "C" As for "A," but with Valves and Peto-Scott Cabinet. Cash or C.O.D. Carriage Paid, £8/8/0, or 12 monthly payments of 15/3.

KIT-BITS

You pay the Postman. We pay post charges on all orders over 10/- G.T. BRITAIN ONLY.

SEND FOR DETAILED LIST OF PARTS.

- | | £ s. d. |
|--|---------|
| 1 Peto-Scott Ready-Drilled Chassis, with Component Brackets | 5 9 |
| 2 Valley Unloader Coils | 15 0 |
| 1 Bulgin Short-wave Coil | 3 6 |
| 1 Jackson Bros. 3-Gang Condenser with Acroplane Dial | 1 0 9 |
| 1 B.T.S. Short-wave Tuning Condenser, with J.B. Acroplane Dial | 10 3 |
| Set of 4 Specified Valves | 2 11 0 |
| 1 Peto-Scott 1936 Superformer Cabinet | 19 6 |
- ANY ITEM SUPPLIED SEPARATELY. CASH. C.O.D.

LISSEN BAND SPREAD S.W.3

FREE BLUEPRINT WITH EVERY KIT.

A new easy-to-build Band Spread tuning Short-Wave Receiver. Range 13 to 55 metres. Complete Kit of components, including ready-drilled chassis and condenser plate, 3 valves and full instructions. Cash or C.O.D. Carriage Paid, £3/9/6, Balance in 11 monthly payments of 6/6.

5/- DOWN

Peto-Scott 1936 UNIVERSAL SHORT-WAVE ADAPTOR-CONVERTER

COVERS 13-80 METRES. Converts your existing battery or A.C. Receiver for operation on short-waves, with no alterations, bringing you America direct, programmes from all over the world. Two hours to build... a lifetime of world-wide radio entertainment!

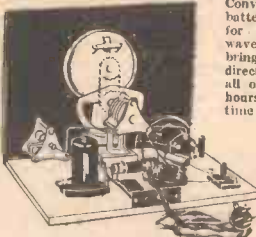

KIT "A"

Comprises all parts for building with full-size blueprint assembly and operating instructions, less Cabinet. Cash or C.O.D. Carriage Paid, £1/19/6, or 2/6 deposit and 10 monthly payments of 4/3.

Send Coupon for Short-Wave Catalogue.

WITH CABINET

Cash or C.O.D. Carriage Paid, £2/10/0, or 12 monthly payments of 4/6.

2/6 DOWN

Peto-Scott A.C./D.C. Short-wave CONVERTER. For A.C. or D.C. Receivers. Tuning Range 13-80 metres. KIT "A," comprising all components, less Valves and Cabinet. Cash or C.O.D. Carriage Paid, £3/10/0, or 12 monthly payments of 6/6.

POST THIS COUPON NOW

- SPEAKERS from 2/6 DOWN.
- ELIMINATORS from 2/6 DOWN.
- RECEIVERS from 5/- DOWN.

PETO-SCOTT CO., LTD., 77 Pr.W.16, City Road, London, E.C.1. Tel: Clerkenwell 910677.

Please send me your New Season's Catalogues. Peto-Scott 1936 Radio Receivers. Speaker and Accessories. Short Wave. "Easiway" General Radio.

Pilot Author Kit Price Lists.

NAME

ADDRESS

Pr.W.16

SECURING MAXIMUM UNDISTORTED OUTPUT

MOST commercial set makers rate their receivers as giving an undistorted output of so many milliwatts or watts, the usual value for a mains set being from 2 to 3½ watts, with five, seven, or even several times this figure for very powerful receivers and amplifiers. The output wattage represents the power available in the speaker circuit, and besides affecting the volume of sound obtainable, it also affects other aspects of the set's performance.

Key Points

Output power is measured in watts, and watts, as most listeners know, are represented by the product of volts and amperes, i.e., these quantities multiplied together. The output of a receiver, then, should be equal to the audio-frequency voltage developed across the load in the output valve anode circuit, i.e., the speaker, multiplied by the audio-frequency current flowing in that circuit. But immediately one complication arises from the fact that we are dealing with alternating current and voltage, and that with alternating currents the wattage only equals volts multiplied by amps. when the load is what is termed "non-reactive," that is to say, behaves as a pure resistance. If, however, the circuit possesses inductance and capacity it becomes "reactive" and the voltage and current are no longer "in phase," that is, they are out of step and the true power is reduced, being represented by the volts multiplied by the amperes and again multiplied by a "power factor," a figure always less than unity, and of a value depending upon the degree to which the current and voltage are out of step.

Now all the known types of speaker are equivalent to a more or less reactive load, so that the power available from any amplifier is never the maximum output which the valve could be made to give if working into a purely resistive load of optimum value. Thus, the "maximum output"—not the maximum *undistorted* output—of any set can only be the maximum obtainable with the particular load conditions imposed by the speaker used. If, however, we attempted to operate a set at this output, we should be appalled by the terrible noise produced, and it would be more than obvious that distortion was being introduced somewhere.

Limitations

In discussing distortion, it will be necessary to confine the examination to distortion occurring in the output stage, because it is output we are considering. It must be remembered, however, that distortion can be, and usually is, introduced in every stage of a set, and proper precautions must be taken to keep it within reasonable bounds. For the purpose of this article, however, it will be assumed that distortion in all the early stages has been avoided either entirely or to such an extent that it is not serious. Under these conditions, what are the limitations to output which risk of distortion imposes on the output stage?

In order to answer this question it must be understood that an output valve only

THE ESSENTIAL POINTS BEARING ON THIS IMPORTANT SUBJECT ARE DISCUSSED IN THIS ARTICLE

By H. J. BARTON CHAPPLE,
B.Sc., A.M.I.E.E.

has a linear response, that is, will only amplify without distortion over a restricted range of signal strength as applied to its grid. Fig. 1 shows the relation between grid volts and anode current of a typical valve as a black line, on perhaps a slightly

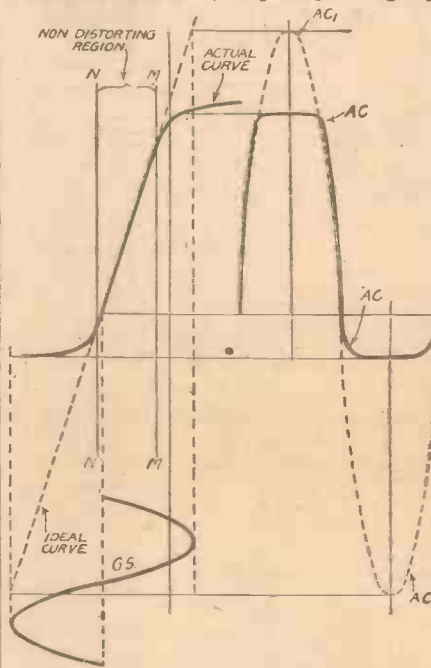

Fig. 1.—A diagram explaining distortion due to valve overloading.

exaggerated scale, and it will be clear that variations of grid signal as represented at GS, would result in variations in anode current as represented at AC. It will also be clear that AC cannot by any stretch of imagination be considered an undistorted replica of GS. Had the valve an ideal performance curve, such as is shown by the

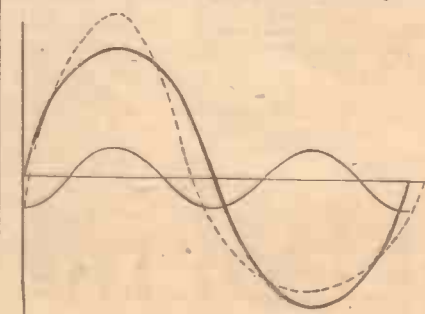

Fig. 2.—Showing how distortion introduces unwanted harmonics.

dotted line, the grid signal GS would produce anode current variations, as shown at AC, and these, it will be seen, are identical in wave form with GS.

Notice also that the ideal performance curve actually coincides with the true curve over a portion of its length, and this gives the clue to undistorted amplification, namely, that the valve must be worked only on this straight portion of its characteristic, or, in other words, the input grid signal must be restricted in amplitude to the limits indicated by the two vertical lines MM and NN. Such restriction limits the maximum output power obtainable free from distortion, and if imposed and the valve is operated at its optimum load impedance, we shall have the maximum undistorted output.

A Physical Conception

Before going into practical ways and means of ensuring maximum undistorted output, we will try to visualise exactly what distortion is from the physical point of view. Mathematicians tell us that a distorted wave, like that shown at AC in Fig. 1, is of the same general form as that obtained by combining a true sine wave with a similar wave of twice the frequency, as shown in Fig. 2. As a matter of fact, all distorted waves can be mathematically analysed and are found to be equivalent to the original wave form with the addition of varying proportions of other waves having twice, three times, four times, and other multiples of the original frequency. These higher frequencies are called harmonics and represent notes more shrill than the original. Thus, a wave of twice the frequency is a note one octave higher than the fundamental; four times the fundamental frequency is two octaves higher, and so on. Distortion, then, means adding harmonics not present in the original programme, thus altering the quality of reproduction, and always making it worse because it is unnatural.

In the case of a triode output valve, the even harmonics, that is, those representing twice or four times the original frequency, and so on, are chiefly found when the valve is overloaded, but with pentodes there is a relatively larger proportion of odd—that is, third, fifth, and seventh harmonics. It should be noted, also, that the odd harmonics are more distressing to the ear than even harmonics.

In Practice

Grid bias, whether obtained by a battery or automatically by the voltage drop in a biasing resistance, must be of the correct value indicated by the valve maker. This ensures that the working point of the valve comes at the centre of the region delimited by the lines MM and NN in Fig. 1, allowing the valve to handle the largest permissible input signal without exceeding the "non-distorting" portion of its characteristic.

Next, the volume control must be used with discretion, and employed not only for keeping the volume of sound down to a comfortable level, but also for restricting the signal voltage applied to the grid of

(Continued on page 123)

Chosen

by *H. Camm*

FOR THE

1936 SUPERFORMER

AIRPLANE DIALS

Two of these handsome dials are embodied in the set. Built on the lines of all J.B. components, they combine extreme rigidity with easy manipulation. Finished in chrome, bronze and oxy-silver.

Single Ratio, Catalogue No. 2130 !! Price 5/9

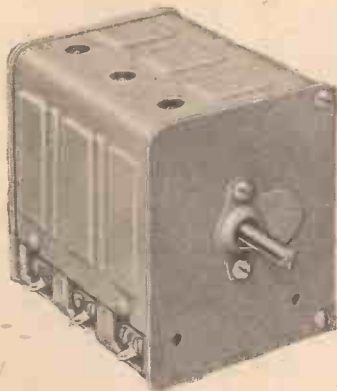
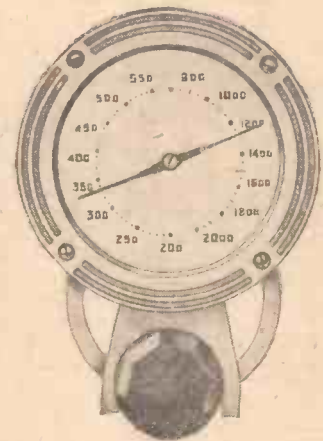

The use of the "Baby Three" shows Mr. Camm to be a man of discrimination. Of unusually compact design, wear and tear is reduced to a minimum by a Ball Bearing Rotor. Screening is unusually complete, ensuring absolute stability! Catalogue No. 2122 !!!!!!! Price 15/6

BABY CONDENSER



CONDENSERS & DIALS

Jackson Bros. (London) Ltd., 72, St. Thomas Street, S.E.1. Telephone HOp. 1837.

CAPSTAN CIGARETTES. 10 for 6d., 20 for 11½d., PLAIN OR CORK TIPPED

**'BETTER
BUY CAPSTAN,**
*they're blended
better*
— they're Wills's!



*— as they say
in the wilds of Chelsea*

SECURING MAXIMUM UNDISTORTED OUTPUT

(Continued from page 120)

the output valve, within the limits given by MM and NN in Fig. 1. As the music performed in the studio varies between very soft and very loud, so does the modulation of the carrier wave vary from a low value to the maximum, and this is reflected in the low-frequency side of the set as increases in the strength of the signal voltage on the output valve grid. So the volume control must be made to restrict this voltage to the indicated value at the moment when the music is at its loudest—it will be much less than this during soft passages, perhaps only a quarter of the value.

How can we be sure that the limit is not being exceeded? There are, of course, sensitive voltmeters of special type which will measure voltages at audio frequency, but there are no instruments which can be incorporated in domestic receivers. An ammeter connected in the anode circuit of the output valve is of some assistance, but here again it is not usual to include one in ordinary broadcast receivers. Quite the best plan is to judge by ear, and to turn down the volume control immediately reproduction appears to be in the slightest degree harsh and objectionable.

The Output Load

By this means, distortion due to over-

loading the output valve can be easily avoided. To ensure *maximum* output without distortion it is also necessary to pay attention to the output load—the speaker with its transformer, if used. It is possible to plot a curve showing the output obtained from a valve for various values of load impedance. This is usually done by valve makers for all their output valves, and on the same chart is also plotted other curves showing the amount of second and third harmonic distortion at various loads. Examination of these curves permits the engineer to select a load impedance at which the output is reasonably high and the distortion level reasonably low, and the "optimum load" quoted by valve makers in their catalogues and packing slips is calculated in this way. It will be understood that it may be possible to obtain a slightly greater output with a different load—but with a greater percentage distortion; and it may be possible to obtain a smaller degree of distortion at some sacrifice of output. But the load figure recommended in all cases is the best possible compromise between two conflicting sets of conditions. The instruction sheets issued with loud-speakers usually give the load impedance provided by the different settings of the matching transformer, and thus permit the optimum setting to be selected.

For ordinary domestic purposes a single output valve of the mains-operated type, either pentode or triode, gives all the output

required with reasonable quality. Even when it is remembered that the valve should be so operated that the maximum output obtainable is four or five times the average, a 2½ to 3-watt output stage suffices for the average room. Greater maximum output may, however, be provided not merely, or even mainly, to produce a greater volume, but to increase the "factor of safety" against distortion during particularly loud musical passages; and big outputs are also wanted for public address work. It is possible to use, in such cases, single output valves, and types are available giving outputs up to 20 watts or more. These are, however, of the high-voltage type, requiring from 400 to 1,000 volts H.T. An alternative is to use two 3-watt valves in push-pull. It might be thought that such an arrangement would make possible a maximum undistorted output just twice that of a single valve, but as a matter of fact rather more than twice the output can be obtained without introducing serious distortion. The reason is that with two valves in push-pull, any even harmonics introduced due to the curvature of the valve characteristic of one valve are cancelled out by those introduced by the second valve, provided the valves themselves are reasonably well matched. It is therefore permissible to apply somewhat higher input signals to their grids, with a consequent increase in output.

A Short-wave Kit Set

Details of an interesting kit of parts which are obtainable from Messrs. Lissen, Ltd.

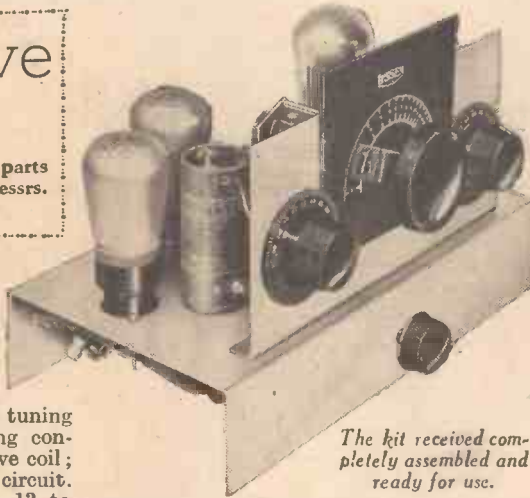

The kit received completely assembled and ready for use.

THE latest kit set to be issued from the Lissen factory takes the form of a Short-wave Three in which the band-spread system of tuning is incorporated. The parts include a stout metal chassis and small metal panel; a standard slow-motion .00025 mfd. tuning condenser; a special band-spreading condenser; special dual-range short-wave coil; and other parts to complete the circuit. The coil covers a total range from 13 to 55 metres, divided into two bands, 13 to 28 and 25.5 to 55 metres, the wave-change

switch being of a special low-loss type. Coupling between the three valves, which are arranged in the familiar detector-2 L.F. circuit, is carried out by means of resistance-capacity coupling in the first stage and an L.F. transformer in the second stage, and the valves specified are of the Ever Ready type, K30C, K30C, and K30G.

Assembly is very simple, as the chassis and panel are ready drilled and the various component parts are fixed in position by

means of nuts and bolts which are provided for the purpose. To assist in this task a

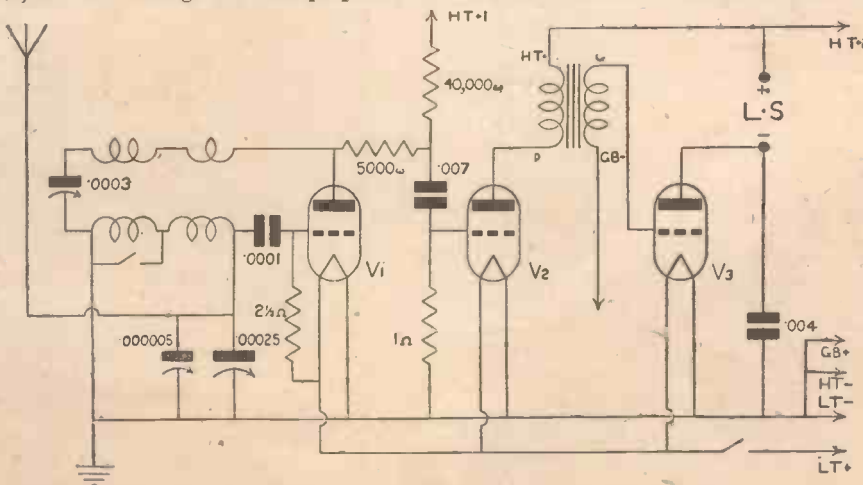

Theoretical circuit of the Lissen Band-spread 3-valve short-wave kit set.

blueprint may be obtained, and a copy of "Short Wave," a small book published by Messrs. Lissen, also contains detailed instructions for this part of the work, as well as providing interesting details of the stations which can be heard, and the best methods of using the receiver. A seven-way battery cord is provided, and the entire work of wiring may be carried out without the use of a soldering iron.

Although the circuit is of the simple type, it should be remembered that on the short waves a three-valver of this nature can give remarkable results under suitable conditions, and many listeners have made a det-2 L.F. set their standard for this type of reception. There are no frills or refinements in the circuit, and the band-spread tuning system removes much of the difficulty usually experienced on the short-waves owing to the extreme sharpness of tuning. Provided that a good aerial and earth is fitted (and the book above mentioned gives details concerning this part of the equipment), it may be relied upon to provide good entertainment at all times. It is necessary, of course, to listen at the correct time on the correct band, in view of the peculiar effects of daylight on certain wavelengths, but again the makers of this kit set have given this information in "Short Wave."

The price of the kit is 69s. 6d., and it includes the three Ever Ready valves. Recommended accessories are an H.T. battery at 7s. 6d., an accumulator at 4s. 6d. and a grid bias battery at 10d.



SHORT WAVE SECTION

The Future of Ultra-short Waves

Advantages of Wavelengths Below 10 Metres are Explained in Simple Language in this Article

ULTRA-SHORT waves are still surrounded with a certain air of mystery and wonder, despite the fact that they have been used in many valuable and convincing experiments in the past couple of years. There is really no reason why they should be looked upon in a spirit of awe by the home constructor, for they present very few difficulties and may prove to be the solution to many awkward problems which confront present-day broadcasting. It has become customary to speak of wavelengths below 10 metres as being ultra-short, although wavelengths of less than 1 metre are now being described as micro-waves, for obvious reasons.

The Development of Short Waves

If we trace the history of wireless transmission over the past fifteen years or so we find that the wavelengths in use have gradually become shorter and shorter. So much is this the case that in the early days of broadcasting wavelengths below 1,000 metres were considered as being short; later the lower limit was arbitrarily shifted to about 200 metres, then to 100 metres, until to-day we generally use the expression when speaking of wavelengths of less than 50 metres. There have been very good reasons for developing the shorter wavelengths, one of the most important being that it has been found that greater distances can be covered with less power as the wavelength is reduced. At least this is true in a general sense, but there are exceptions to the rule, as will be pointed out later. It is worthy of mention in passing that short waves have been pioneered almost entirely by amateur transmitters, who have steadily been driven "down" from 440 metres to 180 metres, 90 metres, 40 metres, 20 metres, and finally to 5 metres. It is one of the romances of short-wave work, in fact, that progress has been made, not just in spite of, but because of the difficulties which have been placed in the path of the amateur. He was prohibited the use of 440 metres soon after the commencement of broadcasting, because this band was required for other purposes; as soon as he demonstrated that shorter wavelengths were both practicable and valuable, he was asked to go still lower, and so on.

"Optical" Range

But we are digressing from the main point of this article. It was stated above that, in general, the range of transmission was increased in inverse ratio to the wavelength, but the limit to this has now been reached, since it is found that the practical range of signals on wavelengths less than 10 metres is "optical" only. That is, the

signals can only be sent as far as one can see—to points on the horizon, as it were. Here again, however, it is possible that means may be devised for exceeding this range in future, for a number of these ultra-short-wave signals have now been received over distances up to 200 miles when their theoretical limit was between twenty-five and thirty miles. Whether the "optical" range can be exceeded for reliable transmission and reception or not, however, the ultra-shorts will still prove invaluable in the future.

More Stations—Less Interference

One reason for this is that a far greater number of transmissions can be accommodated within a given practical tuning range than is the case on medium or long waves. This point is more easily understood when it is borne in mind that wavelengths from about 5 to 8 metres can be covered with a single coil and tuning condenser. On medium waves we can tune from approximately 200 to 600 metres with one coil and



This diagram gives an idea of the difference in frequency range on the long, medium, and ultra-short wavebands.

condenser, and from long waves from about 1,000 to 2,000 metres under the same conditions. At first these figures may appear to be in contradiction to the preceding statement, but it is necessary to think in terms of frequency rather than in wavelengths. Thus, 5 to 8 metres corresponds to a frequency range of 60,000 to about 37,000 kc/s, whereas 200 to 600 metres is equivalent to 1,500 to 500 kc/s, and 1,000 to 2,000 metres, to 300 to 150 kc/s. It is now evident that the band of frequencies embraced by the ultra-short-wave range taken as an example is twenty-three times greater than that of the medium waves, and more than 150 times greater than that of the long-wave band.

Better Quality

If we assume the same frequency separation between stations, this means that twenty-three times as many stations can be accommodated on the U.S.W. as on the medium-wave band, or 150 times as many as on long waves. This fact is bound to prove useful as the number of stations in use increases still further—as it must in the course of time. It might be argued that this would not be of any real value because the range of the U.S.W. transmissions is so limited that only a very few of the available transmissions could be received. On the other hand, those listeners whose chief object is to have high-fidelity reproduction from two or three stations rather than to "roam the world" is rapidly increasing, and the ultra shorts would meet these requirements admirably, making completely-interference-free reception of a few alternative programmes a remarkably simple procedure when using the most inexpensive type of receiver. In any case, it would be a logical plan to arrange for a number of local-service transmitters of low power to operate on the high frequencies and still to allow a few stations intended for world-wide transmission of programmes of international character to use the short waves and even medium waves.

Here it should be mentioned that short waves are quite unsuitable for local service, due to the well-known "skip-distance" effect; the signals travel upward and are reflected by the Heaviside or Appleton layer, returning to the ground only at a distance from the transmitter. Moreover, the short waves are subject to pronounced fading, which is almost entirely absent when using U.S. waves.

Another outstanding advantage of this scheme is that it would permit of the allocation of a much wider frequency band to each transmitter than is at present possible. Whereas existing broadcasting stations can have only a 10 kc/s separation, twice this band width could easily be allowed. The result would be that "perfect" transmissions could be made instead of having to curtail the frequency range and automatically introduce "top cut-off"—which is equivalent to distortion—as at present. When this were done it would be possible to obtain reception indistinguishable from the original sounds transmitted.

U.S.W. for Television

It is because of the advantage just described that ultra-short waves were specified for high-definition television, of which a service will shortly be available. In order to transmit images of similar clarity to those thrown on to the screen in a cinema it is necessary to have a frequency band of approximately 2,000 kc/s. In

other words, a single transmission would cover the whole of the range from 120 to 600 metres. Compare this with the position on ultra shorts, where eleven such transmissions could be accommodated between 5 and 8 metres; by going down to 3 metres and up to 10, something like thirty-five transmissions could be squeezed in.

Even the important advantages described are not all which U.S. waves offer, for transmissions on these high frequencies can easily be focused by means of reflectors and made to follow a straight line or beam. Transmissions of this nature are semi-private and may some day be used as a means of communication as the telephone is to-day. It would be quite an inexpensive matter to install a low-power transmitter and simple receiver for direct communication over distances of 10 miles or more, such as, for example, between various branches of a firm or between the branches and head office. Sharply-focused beams may also prove invaluable for direction finding in the case of aircraft and sea-going vessels, as well as for wireless control in fog.

Whatever future developments there may be, there is already ample interest for the experimenter and constructor in receiving the many 5-metre transmissions made by amateurs; this work will provide a good grounding for high-definition television reception when the service comes into operation in the new year.

Leaves from a Short-wave Log

WITH our return to Greenwich Mean Time, we must also bear in mind that other European countries have altered their clocks on or around the same date. The change has brought back to the normal France, Belgium, Portugal, Holland and the U.S.S.R. The United States went back to their standard time on the last Sunday in September. On the other hand, the Argentine Republic changed over to Summer Time on October 1st, and in consequence the difference between, say, Buenos Aires and London will be three hours, i.e., G.M.T. less three hours until March 30th, 1936. Other countries are not affected by these alterations.

Again, with the advent of the shorter days, we register further changes in wavelengths. PHI, Huizen (Holland) which, during the summer months, has been regularly working on 16.88 metres, from October 6th abandoned this channel for 25.57 metres (11,730 kc/s); the programme schedule remains the same. Remember that the interval signal is a metronome, and that the station closes down with the Netherlands National Anthem. Announcements are made in the Dutch, German, French, English, Spanish and Malayan languages.

CTIAA, Lisbon, which, although a regular worker, is now seldom mentioned, has been recently troubled with interference on 31.25 metres—HBL, Prangins, being the culprit! In order to escape this trouble, there is a strong possibility that on the days when Prangins is active, e.g., Friday night-Saturday morning, the Portuguese may change over to another channel, 25.34 metres (11,840 kc/s), which has been tested in the past and found satisfactory.



It's the part you cannot see that matters

PUT a condenser into circuit and it's the unseen parts which do the job — it's the unseen metal foil — the linen tissue, or mica separators — or the unseen electrolyte which have to provide that essential standard of accuracy and reliability. Upon that standard depends the performance — indeed the very life — of your receiver. Whether you are building a super radiogram or a single valver for the "ultra shorts" you need condensers that are above suspicion . . . condensers with 27 years of pioneer work behind them — Condensers by T.C.C. They are the choice of the leading Set designers and manufacturers — make them your choice and know that what is hidden is right!

T.C.C.
ALL-BRITISH
CONDENSERS

The Telegraph Condenser Co., Ltd.,
Wales Farm Road, North Acton.



JUST ANOTHER "FULLER FEATURE"

Grease Cup Terminals

in
FULLER

RADIO BATTERIES

BESIDES THIS, NOTE THESE OTHER FULLER FEATURES:

- Non-interchangeable Coloured Terminals with Raised Polarity Signs make wrong connections impossible.
- Indestructible Ebonite Separators prolong the life of the accumulator.
- 3 "Mammoth" Full Capacity Plates giving extra capacity.
- Large Filling Vents and heavy moulded glass containers give strength and distinctive appearance.

Puts them miles above the rest!

A FULLER Dry Battery for every set. Always fresh, always good.

ASK YOUR DEALER TO DEMONSTRATE Service Agents throughout the country

The Fuller Accumulator Co. (1926) Ltd., Chadwell Heath, Essex. 'Phone: Seven Kings 1200. 'Grams: Fuller, Chadwell Heath.

PRICE
2/4

THERE'S NO FINER PICK-UP THAN A B.T.H

there's no finer value than the

B.T.H. MINOR PICK-UP AND TONE ARM

The Edison Swan Electric Co. Ltd., 155, Charing Cross Road, London, W.C.2



EDISWAN RADIO

Fitted by leading radiogram manufacturers, preferred by all knowledgeable radio men—the B.T.H. pick-up stands for all that is best in record reproduction equipment. For as little as twenty-one shillings you can have B.T.H. record reproduction. The Minor compares favourably in performance with pick-ups costing very much more. It is supplied complete with volume control fitted in the tone arm pillar. All radio dealers sell it.

Distributors for the British Thomson-Houston Co. Ltd., Rugby



Price and Preference

For many of us, price marks a boundary; but no limit need be set to the enjoyment from one's pipe. Price and preference can be reconciled. Hosts of smokers who first considered cost, now "fill up" with "Airmen" for choice.

MIXTURE
FLAKE
NAVY CUT

10d
PER OZ

NAVY CUT
DE-LUXE !!!

PLAYER'S AIRMAN TOBACCO

The Best Seller of the
Technical Books of 1935

NEWNES
TELEVISION and SHORTWAVE HANDBOOK

by **F. J. GAMM**
(Editor "Practical Television," "Practical and Amateur Wireless," etc.)

EVERYTHING ABOUT—

Drums, Mirror Screws, Scanning Discs and other Scanning Systems, Neon Lamps, the Cathode-Ray Oscillograph. How to build Short-Wave Receivers; How to build Ultra-Short Wave Receivers—straight and superhet.

Fully Illustrated

280 pages Only 3/6 net

From All Booksellers

GEORGE NEWNES, LIMITED

TESTS OF STANDARD RECEIVERS

ON OUR
AERIAL

REVIEWS OF LATEST RECEIVERS

H.M.V. Universal Superhet

ALTHOUGH described by the makers as a "Four," this receiver is actually a three-valve superhet—the fourth valve being a full-wave rectifier. The circuit employed in this interesting model makes use of the reflex principle and employs an heptode, double-diode-pentode and output pentode valves. There are a number of interesting features in the circuit which, as it is of the universal, or all-mains, type, employs no mains transformer. A tapped resistance is provided on the mains side, and this is fed via fuses and a comprehensive filter system, to avoid risk of interference being introduced from the mains. A dial lamp is operated from a tapping on the mains resistance, and the rectifier is fed from this in the usual manner. The heaters of the four valves are series-fed, the order being rectifier, output valve, heptode, and double-diode-triode. The latter, in accordance with the usual principles, is on the earth side of the line, and thus avoids large voltage differences between cathode and earth.

The Circuit

On the aerial side a novel form of interference eliminator is fitted which eliminates difficulties due to the proximity of a powerful station, and this is coupled to the aerial coil through a small condenser. The remainder of the heptode circuit is straightforward, and the output is taken to an I.F. transformer the secondary of which is taken to the control grid of the D.D.T. valve. This portion of the valve thus acts as an intermediate-frequency amplifier, and the output from the anode is taken to the diode portion of the valve. The rectified signal then passes through the valve and is found in the anode circuit, together with the I.F. signal. In this manner the valve performs three separate functions, and the coupling resistance for the low-frequency stage is connected in series with the primary of the I.F. transformer in the anode circuit of the valve and feeds the output pentode in the usual way. A measure of automatic-volume control is provided from the

second valve and assists in controlling the input signal.

Refinements

In accordance with modern design, there are a number of refinements in this H.M.V. receiver, and the user is able, by means of a panel control, to vary the degree of sensitivity and thus to permit the receiver to operate "full out" for distant reception, whilst limiting its power when receiving the local and thus obtaining a higher degree of quality. The panel controls are four in number—the main tuning control, a volume control, a wave-range switch, and the sensitivity switch. The ordinary type of Q.M.B. on-off switch is mounted on the



H.M.V. Model 340.

side of the cabinet. The volume control is of the L.F. grid-potentiometer type, and thus operates smoothly and efficiently, and in the receiver under test was perfectly noiseless in action. There is no mains aerial device with this type of receiver, but two separate aerial terminals are

provided, and these allow of the use of a very small indoor arrangement, or the full outside type of aerial. The sensitivity of the receiver is such that even with 5ft. of wire joined to terminal A2 quite good reception of a number of powerful stations is obtainable. Obviously, to obtain maximum results a really good outside aerial is advisable, when the available programme material will satisfy even the most ambitious.

Test Results

The quality is fully up to the H.M.V. standard and is forward and round in tone. With the full outside aerial the A.V.C. action was quite marked, and the full 2½ watts output could be obtained without distress. The quality from distant stations was of a high order, and there was a noticeable absence of whistle interference. The sensitivity switch was found to be very useful when it was desired to select only the local stations, as it prevented the hesitancy which is usually experienced when one rotates the control knob of a powerful receiver and hears programmes at every degree of the dial. The receiver was noticeably free from hum, but it should be remembered that, when using the set with A.C. mains and experiencing hum, the expedient of reversing the mains plug should be tried, as this generally overcomes the difficulty. On D.C. supplies, of course, it is necessary to maintain the polarity by inserting the plug into the mains socket in the correct manner, and thus some mark should be made to avoid delay should the plug be removed. The fuses are easily accessible, and a spare one is provided on the fuse board for replacement. The price of this model is only 11½ guineas, and it may be used on any type of mains having voltages from 195 to 255 volts, and in the case of A.C. supplies, having frequencies between 25 and 60 c.p.s.

"Round the Northern Repertories"

THE Northern Drama Department is making a new departure on October 13th, when the first of a monthly series, entitled "Round the Northern Repertories," is to commence. This feature will take the form of short Sunday evening performances relayed to Northern listeners by members of Northern Repertory Companies, the Repertory Theatres at Manchester, Liverpool, Sheffield, and Hull being represented. Although these shows will be broadcast from the studios, not relayed direct from the theatres, in every case they will consist of extracts from the play which the particular company in question is performing the next week. The broadcasts will thus constitute somewhat elaborate "trailers" to the theatrical shows.

PROGRAMME NOTES

"European Exchange"

A SHORT time ago there occurred a wireless discussion between a young Englishman and a young German on the respective merits of their countries. This occasioned one of the most lively bursts of correspondence that the Talks Department has enjoyed—and be it noted, this department welcomes such a post. To develop this interest, the Talks Director has devised a series for the autumn called "European Exchange." It is hoped to obtain brilliant

young protagonists of France, Denmark, Russia, Italy, Austria, and Turkey, to discuss their political outlook with young men and women from this country.

Concert from the Pump Room, Bath

DAVID KEAN, whose Concerts in Camera have been so much appreciated by listeners in the West, is responsible for a programme from the Pump Room, Bath, which may best be described as a reconstruction of one of the famous Bath Concerts given at the Assembly Rooms at Bath in the early 1820's. All the music in the production, which will be broadcast on October 25th, has been taken from a collection of songs belonging to David Kean's great-great-grandmother, who lived in the West of England and was in the habit of attending the concerts.



SIGNS of the TIMES

The Budget has restored
POLICE OPPORTUNITIES.

The Air Force is to be increased.
AVIATION MUST DEVELOP.

Pay Cuts have been restored.

CIVIL SERVICE

Suitable to both sexes. Ages 15] to 24.

G.P.O. ENG. DEPT.

CUSTOMS AND EXCISE, INSPECTOR OF TAXES, Etc.
NO EXPERIENCE REQUIRED. OPEN EXAMS.

MATRICULATION

There are many ways of commencing a career, but Matriculation is the jumping off board for all the best ones.

We prepare candidates for all

INSTITUTE EXAMS.

Technical, Accountancy, Secretarial, Insurance, etc.

ENGINEERS AND DRAUGHTSMEN

All Branches—Employers are advertising for them.

TELEPHONY, RADIO and MOTOR ENGINEERING are expanding rapidly. There are lots of vacancies. Our postal courses will make you eligible. Advice on all careers free.

Also ask for our New Book (Free of charge)

THE HUMAN MACHINE

Secrets of Success

YOU CAN HAVE A COLLEGE TRAINING
IN ALMOST ANY CAREER FOR A FEW
SHILLINGS MONTHLY

- | | |
|---|--|
| Accountancy Exams. | Matriculation |
| Advertising and Sales Management | Metalurgy |
| A.M.I. Fire E. Exam. | Mining, all subjects |
| Applied Mechanics | Mining, Electrical Engineering |
| Army Certificates | Motor Engineering |
| Auctioneers and Estate Agents | Motor Trade |
| Aviation Engineering | Municipal & County Engineers |
| Banking | Naval Architecture |
| Boilers | Pattern Making |
| Book-keeping, Accountancy and Modern Business Methods | Police, Special Course |
| B.Sc. (Eng.) | Preceptors, College of Pumps and Pumping Machinery |
| B.Sc. (Estate Management) | Radio Service Engineering |
| Building, Architecture and Clerk of Works | Radio Communication |
| Cambridge Senior School Certificate | Road Making and Maintenance |
| Civil Engineering | Salesmanship |
| Civil Service | Sanitation |
| All Commercial Subjects | Secretarial Exams. |
| Commercial Art | Ship-building |
| Concrete and Structural Engineering | Shortland (Fitzman)'s Structural Engineering |
| Draughtsmanship, all branches | Surveying |
| Engineering, all branches, subjects and examinations | Teachers of Handicrafts |
| General Education | Telephony and Telegraphy |
| G.P.O. Eng. Dept. | Transport Inst. Exams. |
| Heating & Ventilating | Weights & Measures |
| Industrial Chemistry | Inspector |
| Insurance | Welding |
| Mathematics | Wireless Telegraphy and Telephony |
| | Works Managers |

If you do not see your own requirements above, write to us on any subject.



Dept. 104 THE BENNETT COLLEGE SHEFFIELD



COMPONENTS TESTED IN OUR LABORATORY

The Hivac Harries Valve

THE Hivac Harries power output valves are made in accordance with an entirely new principle of design. There are two parts to a tetrode or pentode valve, namely, the cathode space and the anode space. There is ample text-book data on how to design the cathode space, but none on the correct proportioning of the anode space. For some years Mr. J. H. Owen Harries has been investigating the anode space. Its laws of operation and design were made clear and a hitherto unknown anode critical distance was discovered at which the efficiency is much greater than at other distances. The new valves, which have their anodes at this critical distance, are better than older valves which have not this new advantage in design. The Hivac Harries power output mains valve AC/Y has, for instance, over double the power sensitivity of the pentode types hitherto universally used in receivers. It has a greatly improved tonal quality, and a much greater power output. On the High Vacuum Valve Company's stand at Olympia some novel apparatus was seen which alternatively operated a Hivac Harries power valve and a pentode type valve and showed their respective power outputs on a dial. Both valves were working under exactly the same conditions and were of equivalent types, yet the Hivac Harries valve was seen to give almost twice the power output of the other.

The new principle is equally revolutionary in its results with almost every other kind of valve, and new valves improved in this way will later be introduced for H.F. amplification, ultra-short waves, television, and many other purposes.



The non-resonant lining to the W/B cabinet may be seen in this illustration.

W/B Non-resonant Cabinet

THE new W/B cabinet type loud-speakers are fitted into a special non-resonant mounting, and the attached

illustration will no doubt prove interesting to readers who are anxious to understand how various schemes have been developed to enable these small cabinets to be employed without spoiling the quality of reproduction. In the illustration it will be seen that the entire inner surface of the cabinet is lined with a thick material of a non-resonant nature, whilst the cabinet itself is composed of extra thick wood. As a result of many tests and experiments, Messrs. Whiteley Electrical have found that when the cabinet is suitably designed as to its proportions, and the correct type of speaker is incorporated with this non-resonant lining, the reproduction is slightly better than is obtained with the same speaker on the ordinary domestic baffle. Those readers who have heard this particular model will, of course, bear witness to this statement, as the reproduction is certainly of a very high standard. The extra cost of this cabinet with Model 36J speaker is 17s., and this includes a volume control. If the Model 36S is preferred, it may be obtained with the control and cabinet for an additional cost of one guinea.

A Lightning Radio Calculator

READERS who are in difficulty concerning mathematical calculations when carrying out experiments will be interested in a special calculator which is obtainable from F. L. Postlethwaite, Esq., of 41, Kinfauns Road, Goodmayes, Ilford. This calculator is produced by the American Radio Relay League, and solves the problems of frequency, wavelength, inductance, capacity, coil and wire sizes, and so on. It consists of a stout card measuring approximately 11in. by 9in., and attached to the centre is a transparent celluloid cursor with a fine hair-line engraved in the centre. Attached to the same point are two discs, one circular and the other cut to a special "law." The various scales are engraved on the card and on these two discs, and by turning the discs and using the cursor it is possible to make the various calculations mentioned above. A rule is printed on each side, one being in inches and one in centimetres, and full directions for use are given on the back of the calculator, together with a table of equivalents. The price is 4s. 6d. post free from the above address.

New Dubilier Condenser

IN connection with certain new valves which are appearing on the market there has arisen a demand for a 10 mfd. condenser of 750 volt D.C. working type, and Messrs. Dubilier are arranging to place on the market an oil-immersed condenser of this type which will be listed at 17s. The condenser will be similar in appearance to the existing range of 951 condensers.

ABOUT MULTIPLE VALVES

(Continued from page 82, Oct. 5th)

We will now discuss multiple valves and consider them in the order in which they appear in different types of receiver.

Take, first of all, the frequency changer, a type of valve which has been greatly modified since the introduction of multiple valves. For frequency changing a source of oscillations at heterodyne frequency is required, and a mixer where the local oscillations are combined with the signal oscillations to produce the intermediate frequency. An obvious method of achieving this is by using a triode oscillator, and a mixer of the screen-grid or screened pentode type. This can be done by separate valves, or by a multiple valve, and in the latter case either one or two electron streams may be employed.

Examples of the use of a single electron stream are the heptode and the octode, the former functioning as triode oscillator and variable- μ screen-grid mixer, and the latter as triode oscillator and variable- μ screened pentode mixer. In each case a single electron stream, produced from a single cathode, is first made to oscillate at heterodyne frequency by reaction coupling between the first two grids (grid 2 being, in effect, the oscillator anode) and then remodulated at signal frequency at the control grid. Frequency changers employing two electron streams are represented by the triode-pentode, in which the local oscillator system, although quite separate from the mixer portion and requiring external coupling to the mixer, is enclosed in the same bulb.

On the Detector Side

Multiple valves associated with speech detection seem to have settled down to double-diodes and double-diode-triodes. The last mentioned were, of course, the first to be introduced, and while providing diode detection, making for high quality reproduction, and an additional diode for A.V.C., included a triode L.F. amplifier to compensate for the lack of amplification in the diode detector. It is really to the double-diode-triode that we owe the practical development of that useful circuit refinement known as A.V.C. with its power of compensating, to a great extent, for many kinds of fading. Those who experimented with automatic volume control before the days of the double-diode-triode will recall how crude were the circuits, and how erratic their behaviour. A.V.C. to-day is certain in its action, and the circuit is extremely simple to build and to understand.

But the necessity for the triode portion is not now so great, and as a result double-diodes without an amplifying element are becoming quite standard practice. The reasons are threefold. In the first place, with two efficient high-frequency stages or their equivalent, very little amplification is necessary after the diode detector and, in fact, when using the new high sensitivity pentodes in the output stage, no other L.F. amplification at all is required. Secondly, it is not a very easy matter to arrange switching for the triode part of a double-diode-triode to act as first L.F. amplifier for gramophone reproduction, and many designers prefer to use a separate L.F. valve for this purpose. Next, the double-diode-triode restricts the designer to triode amplification whereas, for many purposes, a straight screened pentode has decided advantages for this duty. It would appear, therefore, that while the triple-purpose double-diode-triode was of real practical value in permitting the full development of A.V.C., in many cases we

can get along quite well with the simpler and less expensive double-diode.

Mention has just been made of the high sensitivity output pentode which gives something over 3 watts of output for an audio-frequency signal of between 3 and 4 volts. Since this valve can follow immediately after a diode detector, it was but natural that a multiple valve comprising detector and A.V.C. diodes, and high slope output pentode should be developed, thus assisting in the materialisation of the successful three-valve superhet.

Conclusions

Now comes a new combination—in addition to the double-diode pentode, we now have the pentode-double-diode, in which the pentode portion (this time a high frequency pentode) precedes the detector and A.V.C. sections. Its main use is as radio-frequency or intermediate-frequency amplifier with speech detector and A.V.C.,

but it may also be employed as detector, A.V.C. valve, and low-frequency amplifier in much the same way as a double-diode-triode. Alternatively, the two diodes may be used for detection and A.V.C., and the pentode portion employed in a reflex arrangement as both I.F. and L.F. amplifier, thus providing four stages in a single valve.

Having thus briefly reviewed the whole position of multiple valves, we are left to form our own conclusions. Certainly the choice available is sufficiently wide to enable every constructor to satisfy his own fancy, but it is probable that most will agree that the advent of the recent number of multiple valves has been of value in permitting many circuit devices to be developed to the full, to the great advance of general radio technique, at the same time with the reservation that the number of types brought out was unnecessarily large (for we have omitted all mention of a number of types which had but a short period of popularity).

TRAINED MEN URGENTLY NEEDED

YOU CAN QUALIFY FOR HIGHLY PAID RADIO POSITIONS



R. HEATH BRADLEY, Principal of T.C.R.C.

Thousands of the Technical Experts who are now in well-paid regular employment started radio as a hobby. Their hobby has brought them success.

You, too, can study at home and qualify for interesting and well-paid radio work. Inventing, Designing, Research and Laboratory work, Technical writing, Installation, Maintenance, Testing, Servicing, Set building, and many other specialised occupations are open to the man who knows radio thoroughly. Radio offers rich rewards to the trained man.

We can train you and introduce you to employers, or teach you how to earn money in your spare time. We have helped others; we can help you.

Our Correspondence Courses are praised and recommended by leading Radio Manufacturers and the Technical Press. We specialise in radio and all our Courses are conducted by Radio Experts with practical knowledge of the qualifications that lead to success, employment and a good income.

Qualify for Highly-paid Work.

Students write as follows:—

"I am pleased to say that I have secured a post since starting the course with you, which promises good prospects."

"I have succeeded in obtaining a position in a wireless workshop. The position was only obtained because I mentioned your course."

"I am indebted to you for this situation. Without the Course I should not have lasted five minutes."

"He engaged me at a big increase in salary."

"Since enrolling I have taken over practically all the battery-set work for a local dealer." (Spare-time work.)

"I would have been lost had I not covered most of the Course when I was engaged." (Many others testify to the value of T.C.R.C. training.)

Are you content to remain an onlooker whilst others seize the highly-paid jobs? Are you wasting precious hours when you should be preparing for well-paid employment and an assured future?

Why jog along in the same old rut? Why fear the consequences of losing your job? Why waste your valuable spare-time?

Wherever you live and whatever you do, radio offers you success, security and a spare-time income.

SEND FOR OUR FREE BOOK, WHICH SHOWS YOU HOW TO ACHIEVE PROSPERITY!

Our intensely interesting book tells you how you can become a radio expert in your spare time. It shows how we can set you on the high road to success—to better pay and a secure position or to profitable spare-time work if preferred. This book is FREE. You can have a copy for the asking by filling in the coupon below. DON'T DELAY—send for your copy now!

Technical & Commercial RADIO COLLEGE
 CROMWELL HOUSE
 HIGH HOLBORN LONDON W.C.1
 Telephone Chancery 7054 & 7055

FILL IN THIS COUPON FOR FREE BOOKLET WHICH WILL HELP YOU TO SUCCESS!
 To: T. & C. RADIO COLLEGE, Cromwell House, High Holborn, London, W.C.1
 Please send me a free copy of your book describing your training and telling me how I can make more money.
 NAME
 ADDRESS
 P.R.31.
 (Post in unsealed envelope, 1d. stamp.)

Practical and Amateur Wireless BLUEPRINT SERVICE

PRACTICAL WIRELESS. STRAIGHT SETS. Battery Operated.

One-valve : Blueprints, 1s. each.	Date of Issue	No. of Blueprint
All-Wave Unipen (pentode)	14.10.33	PW31A
Two-valve : Blueprints, 1s. each.		
All-Wave Two (D, Pen)	10.9.33	PW28
Four-Range Super-Mag. Two (D, Pen)	11.8.34	PW36B
Three-valve : Blueprints, 1s. each.		
Bijou Three (SG, D, Pen)	29.10.32	PW5
Argus Three (SG, D (pen), Pen)	12.11.32	PW6
Solo Knob Three (D, 2 L.F. (trans.))	10.12.32	PW8
Selectone Battery Three (D, 2 L.F. (trans.))		PW10
Alpha Q.P.P. Three (D, Q.P.P.)	25.3.33	PW14
Ferrocart Q.P.P. Hi-Mag Three (SG, D, Q.P.P.)	25.3.33	PW15
Three-Star Nicore (SG, D (SG), Pen)	24.6.33	PW24
Auto-B Three (D, L.F., Cl. B)	10.9.33	PW27
F.J.C. 3-valve A.V.C. (Transfer Print) (SG, D, Pow.)		PW32
Sixty-Shilling Three (D, 2 L.F. (R.C. & trans.))	2.12.33	PW34A
Leader Three (SG, D, Pow.)	3.3.34	PW35
Summit Three (HF Pen, D, Pen)	18.8.34	PW37
All-Pentode Three (HF Pen, D (pen), Pen)	22.9.34	PW39
Hall-Mark Three (SG, D, Pow.)	8.12.34	PW41
Hall-Mark Cadet (D, L.F., Pen (R.C.))	23.3.35	PW48
F. J. Camm's Silver Souvenir (HF Pen, D (pen), Pen) (All-Wave Three)	13.4.35	PW48A
Genet Midget (D, 2 L.F. (trans.))	June '35	PM1
Cameo Midget Two (D, 2 L.F. (trans.))	8.8.35	PW51
1936 Sonotone Three-Four (HF Pen, HF Pen, Westector, Pen)	17.8.35	PW53
Battery All-wave Three (D, 2 L.F. (R.C.))	3.8.35	PW56
Four-valve : Blueprints, 1s. each.		
Fury Four (2 SG, D, Pen)		PW11
Beta Universal Four (SG, D, L.F., Cl. B)	15.4.33	PW17
Radiopax Class B Four (SG, D, L.F., Cl. B)	27.5.33	PW21
Nucleon Class B Four (SG, D (SG), L.F., Cl. B)	6.1.34	PW34B
Fury Four Super (SG, SG, D, Pen)		PW34C
Battery Hall-Mark 4 (HF Pen, D, Push Pull)	2.2.35	PW46
Five-valve : Blueprints, 1s. each.		
Superset (SG, SG, D, L.F., Cl. B)	10.9.33	PW26
Mains Operated.		
Two-valve : Blueprints, 1s. each.		
A.C. Twin (D (pen), Pen)	22.4.33	PW18
A.C.-D.C. Two (SG, Power)	7.10.33	PW31
Selectone A.C. Radiogram Two (D, Pow.)	20.4.33	PW19
Three-valve : Blueprints, 1s. each.		
Mains Express Three (SG, D, Pen)	8.10.32	PW3
Double-Diode-Triode Three (HF Pen, D, D.T., Pen)	10.6.33	PW23
D.C. Ace (SG, D, Pen)	16.7.33	PW25
A.C. Three (SG, D, Pen)	16.9.33	PW29
A.C. Leader (HF Pen, D, Power)	7.4.34	PW35C
D.C. Premier (HF, Pen, D, Pen)	31.3.34	PW35B
Ubique (HF Pen, D (Pen), Pen)	28.7.34	PW36A
Armada Mains Three (HF Pen, D, Pen)	18.8.34	PW38
F. J. Camm's A.C. All-Wave Silver Souvenir Three (HF Pen, D, Pen)	11.5.35	PW50
"Allwave" A.C. Three (D, 2 L.F. (R.C.))	17.8.35	PW54
A.C. 1936 Sonotone (HF Pen, HF Pen, Westector, Pen)	31.8.35	PW56
Four-valve : Blueprints, 1s. each.		
A.C. Quadpack (SG, SG, D, Pen)	2.12.33	PW34
A.C. Fury Four (SG, SG, D, Pen)	25.2.33	PW20
A.C. Fury Four Super (SG, SG, D, Pen)	10.2.34	PW34D
A.C. Hall-Mark (HF Pen, D, Push-Pull)		PW45
Universal Hall-Mark (HF Pen, D, Push-pull)	9.2.35	PW47

SUPERHETS.

Battery Sets : Blueprints, 1s. each.		
Supersonic Six (Six valve)		PW16
Premier Super (Five valve)	23.9.33	PW30
£5 Superhet (Three valve)		PW40
Mains Sets : Blueprints, 1s. each.		
Luxus A.C. Superhet (four valve)	14.10.33	PW33
A.C. £5 Superhet (three valve)	24.11.34	PW43
D.C. £5 Superhet (three valve)	1.12.34	PW42
Universal £5 Superhet (three valve)	15.12.34	PW44
F. J. Camm's 2-valve superhet (two valve)	13.7.35	PW52

SHORT-WAVE SETS.

Two-valve : Blueprints, 1s. each.		
Midget Short-wave Two (D, Pen)	15.9.34	PW38A
Three-valve : Blueprints, 1s. each.		
Empire Short-wave Three (D, 2 L.F. (R.C. and Traus))		PW7
Experimenter's Short-wave Three (SG, D, Power)	23.9.33	PW30A
PORTABLES.		
Three-valve : Blueprints, 1s. each.		
Atom Lightweight Portable (SG, D, Pen)	2.6.34	PW36
Four-valve : Blueprints, 1s. each.		
Featherweight Portable Four (SG, D, L.F., Cl. B)	6.5.33	PW12
MISCELLANEOUS.		
S.W. Converter-Adapter (1 valve)	23.2.35	PW48A
AMATEUR WIRELESS AND WIRELESS MAGAZINE. CRYSTAL SETS.		
Blueprints, 6d. each.		
Four-station Crystal Set		AW427
1934 Crystal Set	4.8.34	AW444
150-mile Crystal Set		AW450

STRAIGHT SETS. Battery Operated.

One-valve : Blueprints, 1s. each.		
B.B.C. One-valver		AW344
B.B.C. Special One-valver		AW387
Twenty-station Loud-speaker One-valver (Class B)		AW449
Two-valve : Blueprints, 1s. each.		
Melody Ranger Two (D, Trans)		AW388
Full-volume Two (SG, Det, Pen)	17.6.33	AW392
Iron-core Two (D, Trans)		AW395
Iron-core Two (D, Q.P.P.)	12.8.33	AW396
B.B.C. National Two with Lucerne Coil (D, Trans)		AW377A
Big-power Melody Two with Lucerne Coil (SG, Trans)		AW338A
Lucerne Minor (D, Pen)		AW426
Family Two (D, Trans)		WM278
Three-valve : Blueprints, 1s. each.		
8 Radiogram (D, RC, Trans)		AW343
P.T.P. Three (Pentode-Triode Pentode)	June '35	WM389
Class-B Three (D, Trans, Class B)	22.4.33	AW386
New Britain's Favourite Three (D, Trans, Class B)	15.7.33	AW394
Home-Built Coil Three (SG, D, Trans)	14.10.33	AW404
Fan and Family Three (D, Trans, Class B)	25.11.33	AW410
£5 5s. S.G.3 (SG, D, Trans)	2.12.33	AW412
1934 Ether Searcher : Baseboard Model (SG, D, Pen)	20.1.34	AW417
1934 Ether Searcher, Chassis Model (SG, D, Pen)	3.2.34	AW419
Lucerne Ranger (SG, D, Trans)		AW422
Coscor Melody Maker with Lucerne Coils		AW423
P.W.H. Mascot with Lucerne Coils (D, RC, Trans)	17.3.34	AW337A
Mullard Master Three with Lucerne Coils		AW424
Pentaquester (HF Pen, D, Pen)	14.4.34	AW431
£5 5s. Three : De Luxe Version (SG, D, Trans)	19.5.34	AW435
Lucerne Straight Three (D, RC, Trans)		AW437
All Britain Three (HF Pen, D, Pen)		AW448
"Wireless League" Three (HF Pen, D, Pen)	3.1.34	AW451
Transportable Three (SG, D, Pen)		WM271
Multi-Mag Three (D, 2 Trans)		WM288
Percy Harris Radiogram (HF, D, Trans)	Aug. '32	WM294
£6 6s. Radiogram (D, RC, Trans)	Apr. '33	WM318
Simple-tune Three (SG, D, Pen)	June, '33	WM327
Tyers Iron-core Three (SG, D, Pen)	July '33	WM330
C.B. Three (D, L.F., Class B)		WM333
Economy-pentode Three (SG, D, Pen)	Oct. '33	WM337
All-wave Three (D, 2LF)	Jan. '34	WM348
"W.M." 1934 Standard Three (SG, D, Pen)		WM351
£3 3s. Three (SG, D, Trans)	Mar. '34	WM354
Iron-core Band-pass Three (SG, D, QP21)	June '34	WM362
1935 £6 6s. Battery Three (SG, D, Pen)	Oct. '34	WM371
Graduating to a Low-frequency Stage (D, 2LF)	Jan. '35	WM378
Four-valve : Blueprints, 1s. 6d. each.		
05/- Four (SG, D, RC, Trans)		AW370
"A.W." Ideal Four (2SG, D, Pen)	16.9.33	AW402
2 H.F. Four (2SG, D, Pen)		AW421
Crusaders' A.V.C. 4 (2 HF, D, QP21)	18.8.34	AW445
(Pentode and Class-B Outputs for above : blueprints 6d. each)	25.8.34	AW445A
Quadradyne (2SG, D, Pen)		WM273
Calibrator (SG, D, RC, Trans)	Oct. '32	WM300
Table Quad (SG, D, RC, Trans)		WM303
Calibrator de Luxe (SG, D, RC, Trans)	Apr. '33	WM316

These blueprints are full-size. Copies of appropriate issues containing descriptions of these sets can in most cases be obtained as follows:— "Practical Wireless" at 4d., "Amateur Wireless" at 4d., "Practical Mechanics" at 7½d., and "Wireless Magazine" at 1/3, post paid. Index letters "P.W." refer to "Practical Wireless" sets, "P.M." to "Practical Mechanics" sets, "A.W." refer to "Amateur Wireless" sets, and "W.M." to "Wireless Magazine" sets. Send, preferably, a postal order (stamps over sixpence unacceptable) to "Practical and Amateur Wireless" Blueprint Dept., Geo. Newnes, Ltd., 8-11, Southampton Street, Strand, W.C.2.

Self-contained Four (SG, D, L.F., Class-B)	Aug. '33	WM331
Lucerne-Straight Four (SG, D, L.F., Trans)		WM350
£5 5s. Battery Four (HF, D, 2LF)	Feb. '35	WM381
The H.K. Four	Mar. '35	WM354
Five-valve : Blueprints, 1s. 6d. each.		
Super-quality Five (2HF, D, RC, Trans)	May '33	WM320
New Class-B Five (2SG, D, L.F., Class-B)	Nov. '33	WM340
Class-B Quadradyne (2SG, D, L.F., Class-B)	Dec. '33	WM344
1935 Super Five (Battery Superhet)	Jan. '35	WM379

Mains operated.		
Two-valve : Blueprints, 1s. each.		
Consocentric Two (D, Pen) A.C.	23.9.33	AW403
Economy A.C. Two (D, Trans) A.C.		WM286

Three-valve : Blueprints, 1s. each.		
Home-lover's New All-electric Three (SG, D, Trans) A.C.	25.3.33	AW383
S.G. Three (SG, D, Pen) A.C.	3.6.33	AW390
A.C. Triodyne (SG, D, Pen) A.C.	19.8.33	AW399
A.C. Pentaquester (HF, Pen, D, Pen) A.C.	23.6.34	AW439
D.C. Calibrator (SG, D, Push-pull Pen) D.C.	July '33	WM328
Simplicity A.C. Radiogram (SG, D, Pen) A.C.	Oct. '33	WM338
Six-guinea A.C./D.C. Three (HF Pen, D, Trans) A.C./D.C.	July '34	WM364
Mantovani A.C. Three (HF Pen, D, Pen) A.C.	Nov. '34	WM374

Four-valve : Blueprints, 1s. 6d. each.		
A.C. Melody Ranger (SG, DC, RC, Trans) A.C.		AW380
A.C./D.C. Straight A.V.C.4 (2 HF, D, Pen) A.C./D.C.	8.9.34	AW446
A.C. Quadradyne (2 SG, D, Trans) A.C.		WM379
All Metal Four (2 SG, D, Pen)	July '33	WM329
"W.M." A.C./D.C. Super Four	Feb. '35	WM382
Harris Jubilee Radiogram	May '35	WM386

SUPERHETS.		
Battery Sets : Blueprints, 1s. 6d. each.		
1934 Century Super	9.12.33	AW413
Super Senior		WM256
1932 Super 60		WM269
Q.P.P. Super 60	Apr. '33	WM319
"W.M." Stenode	Oct. '34	WM373
Modern Super Senior	Nov. '34	WM375

Mains Sets : Blueprints, 1s. 6d. each.		
1934 A.C. Century Super, A.C.	10.3.34	AW425
1932 A.C. Super 60, A.C.		WM272
Seventy-seven Super A.C.		WM305
"W.M." D.C. Super, D.C.	May '33	WM321
Merrymaker Super, A.C.	Dec. '33	WM345
Heptode Super Three, A.C.	May '34	WM359
"W.M." Radiogram Super, A.C.	July '34	WM366
"W.M." Stenode, A.C.	Sep. '34	WM370
1935 A.C. Stenode	Apr. '35	WM385

PORTABLES.		
Four-valve : Blueprints, 1s. 6d. each.		
General-purpose Portable (SG, D, RC, Trans)		AW351
Midget Class-B Portable (SG, D, L.F., Class B)	20.5.33	AW389
Holiday Portable (SG, D, L.F., Class B)	1.7.33	AW393
Family Portable (HF, D, RC, Trans)	22.9.34	AW447
Town and Country Four (SG, D, RC, Trans)		WM282
Two H.F. Portable (2 SG, D, QP21)	June '34	WM363
Tyers Portable (SG, D, 2 Trans)	Aug. '34	WM367

SHORT-WAVERS. Battery Operated.		
One-valve : Blueprints, 1s. each.		
S.W. One-valve		AW329
S.W. One-valve for America		AW429
Roma Short-waver	10.11.34	AW452

Two-valve : Blueprints, 1s. each.		
Home-made Coil Two (D, Pen)	14.7.34	AW410
Three-valve : Blueprints, 1s. each.		
World-ranger Short-wave 3 (D, RC, Trans)		AW355
Experimenters' 5-metre Set (D, Trans, Super-regen)	30.6.34	AW438
Experimenter's Short-waver	Jan. 10, '35	AW463
Short-wave Adapter	Dec. 1, '34	AW456
Superhet, Converter	Dec. 1, '34	AW457
The Carrier Short-waver	July '35	WM390

LETTERS FROM READERS



The Editor does not necessarily agree with opinions expressed by his correspondents.

All letters must be accompanied by the name and address of the sender. (not necessarily for publication).

A Few Suggestions

SIR,—As a regular reader of PRACTICAL AND AMATEUR WIRELESS I am taking the liberty, with some temerity, of offering some suggestions for widening the scope and interest of your paper.

I have a really earnest desire to launch out into set-building as a hobby, and it is because of this that the following suggestions are made:

(1) The inclusion in the Beginners Supplement of articles giving more prominence to the constructional side. There seems to be a tendency to omit the simpler instructions in deference to the opinions of more experienced readers. Admittedly there are books dealing with set-building, but I suggest that new constructors would favour making their sets from current designs, and using up-to-date components.

(2) Wherever possible, the abolition of the necessity for soldering, and a clear statement on this point with each published design. Experienced constructors may vote for the use of the iron, but terminals must surely appeal to the beginner, especially if he contemplates fairly frequent dismantling and reconstruction.

(3) The elimination of the bugbear of the L.T. accumulator, with the advent of the cheap and mass-produced all-mains set; there must be very many prospective constructors who would make a hobby of the smaller battery (especially short-wave) sets but for the nuisance of the L.T. battery. There is bound to be considerable family objection to charging at home, and charging stations are not always what they might be in bringing a cell up to scratch. I suggest the use of dry cells (e.g., bicycle-lamp batteries, or the latest magnesium batteries, if available), and that the operation of any necessary meter and rheostat would be quite instructive to the beginner.

(4) A course of set-building for the beginner, commencing with a progressive collection of parts, and instructional testing with cheap meters, and culminating in the assembly of complete receivers.—**JOHN V. BURT (Dundee).**

[With reference to your fourth suggestion, a series of practical articles entitled "The Progressive Experimenter," which were published in our October 21st, 1933, and following issues, deal fully with the subject mentioned.—Ed.]

Reception Conditions in East Africa

SIR,—My thanks are due for the two books, "Wireless Constructor's Encyclopedia," and "Everyman's Wireless Book," which I received recently. They are books that should be in every enthusiast's hand—veritable storehouses of knowledge explained with such simplicity.

Our conditions for reception are, I think, more difficult than those at home, especially living thousands of miles from regular medium-wave stations, such as Nairobi, Johannesburg, Maritzburg, Grahamstown, and Cape Town. Salisbury and Bulawayo are bi-weekly, and are of not very long duration. We have only about three months of really good reception on these stations: July, August, September; the rest of the time we are troubled by atmospherics.

From the foregoing it will be realised that the greater part of reception is done on the short waves, which are generally satisfac-

tory: Daventry, Zeesen, Paris, ZTJ, CR7AA and PCJ are our best stations. Americans, such as Bound Brook, Pittsburgh, Schenectady, are good only at certain times of the year. Headphone work on most short waves can be classed at R6. Our biggest problem is fading. Australian stations are out of the question, and when logged are reckoned to be quite a capture.

I am keenly interested in the two H.F. Pentode Superhet, using a Westector, which was published in a recent issue.

Would it be possible to increase the output by the addition of push-pull amplification or Class B?

I believe that such a circuit will be greatly appreciated and will be adopted quite universally.—"YDNAS" (Vila Pery, Portuguese East Africa).

[We do not recommend the addition of an amplifier to the set mentioned.—Ed.]

Appreciation from Overseas

SIR,—Although a new-comer to the ranks of PRACTICAL AND AMATEUR WIRELESS subscribers, allow me to take this opportunity of congratulating you on the amalgamation of two fine radio journals. I notice the interest in transmission aroused by J. Johnson in the July 20th issue, and would be pleased to see a further improvement in PRACTICAL AND AMATEUR WIRELESS by the addition of a page or so devoted to the subject of transmission. In the August 10th issue, R. Jenkins complains of the scarcity of books dealing with amateur transmitting, and I can safely recommend the "Radio Amateurs' Handbook," which deals with short and ultra-short wave transmission and reception.—**C. GRAHAM BOTHA (Cape Town, S. Africa).**

Transmitting Data

SIR,—I would like to add my voice to that of Mr. Stanley Mears, 2BGJ, in his plea for more articles of interest to the amateur transmitter.

I have taken PRACTICAL AND AMATEUR WIRELESS since its inception, as I realised that it was destined to become the foremost radio journal in the country, which it undoubtedly now is, and while it provides excellent reading and keeps one in touch with developments in the radio world, it seems to me that a little more space devoted to the interests of the amateur transmitter would be very welcome. In view of the part played by the British amateur during the last twenty years in the furtherance of radio knowledge, especially on the short waves, no one will deny that he deserves some acknowledgment.—**GILBERT H. VICKERS, G6GV (Prestwich).**

An Interesting Log

SIR,—I have been an interested reader of your publications since almost the first edition. I think that PRACTICAL AND AMATEUR WIRELESS is well in advance of most other Radio books, although I am sure that a bigger short-wave section each week would be well received by enthusiastic readers. I have owned a short-waver for some time past, a det. pen. RCC., using D.C. mains for my H.T. supply. I have logged a number of stations on this set, and have verified the following stations:—**VE9GW, CGA3, VQ7LO, FYA, OXY,**

SUV, RW59, PHI, DJA, B, C, D, and DJN, LSQ, HVJ, HJIABB, YV6RV, CTIGO, OH2NE, LAIG, VUB, PRF5, EAQ, 2RO, VK3LR, W2XAF, K4SA, HAS3, COC, CT1AA, OER2, HB9T, also the Empire Station, and a number of British amateurs, including G6SR, G5NW, G5RX, etc. I always send either a stamp or an International Reply Coupon when reporting stations, and I find that nearly every station replies when this is done. Wishing your paper every success.—H. G. BURGESS (Brighton).****

Another Circuit Wanted

SIR,—I should like to see published in PRACTICAL AND AMATEUR WIRELESS a circuit for the home constructor on the following lines: Battery operated, base-board type, with two separate tuning condensers, push-pull output, and suitable for the reproduction of gramophone records. It would be interesting to know what other readers think of this suggested circuit.—**G. MANNING (Chatham).**

Set for Hospital Use Wanted

SIR,—I have been a constant reader of your paper, PRACTICAL WIRELESS, since its inception, and am an enthusiastic constructor.

Unfortunately, owing to a serious accident, I am now a patient in a Welsh hospital, where I am likely to be for some time. My unhappiness is increased by the fact that there is no wireless at the hospital, so may I appeal to any reader who happens to have an old set on hand that he does not require for his own use, such as a battery or all mains (A.C., 25 cycle). I can assure you that I and my fellow patients would be very grateful for such a gift.—**TREVOR LLOYD (Wales).**

[If any reader desirous of getting in touch with Mr. Lloyd will enclose a stamped addressed envelope the letter will be forwarded.—Ed.]

CUT THIS OUT EACH WEEK.

Do you know

—THAT many modern ultra-short-wave components are now provided with silver-plated metal parts.

—THAT the reason underlying the above arrangement is that the skin resistance is lowered by adopting silver for the surface.

—THAT bearing the above remarks in mind, ordinary brass used in ultra-short-wave receivers should be kept highly polished and free from oxidation.

—THAT an efficient tuning coil should be wound so that the over-all diameter is greater than its length.

—THAT when using "mixed" L.F. couplings it is preferable to place the best coupling first, and therefore an R.C. stage should precede a transformer-coupled stage.

—THAT as a general rule modern valves should only be mounted in a vertical position.

—THAT when horizontal control is desired, the receiver should be placed in the usual position, and the condenser drive and other controls carried out through flexible cables.

—THAT when a radio-gram is not fitted with a change-over switch, radio break-through should be avoided by disconnecting the aerial and not by disconnecting the voltage supplies to the early valves, or by removing those valves.

The Editor will be pleased to consider articles of a practical nature suitable for publication in PRACTICAL AND AMATEUR WIRELESS. Such articles should be written on one side of the paper only, and should contain the name and address of the sender. Whilst the Editor does not hold himself responsible for manuscripts, every effort will be made to return them if a stamped and addressed envelope is enclosed. All correspondence intended for the Editor should be addressed: The Editor, PRACTICAL AND AMATEUR WIRELESS, Geo. Newnes, Ltd., 8-11, Southampton Street, Strand, W.C.2.

Owing to the rapid progress in the design of wireless apparatus and to our efforts to keep our readers in touch with the latest developments, we give no warranty that apparatus described in our columns is not the subject of letters patent.

last word in condensers . .

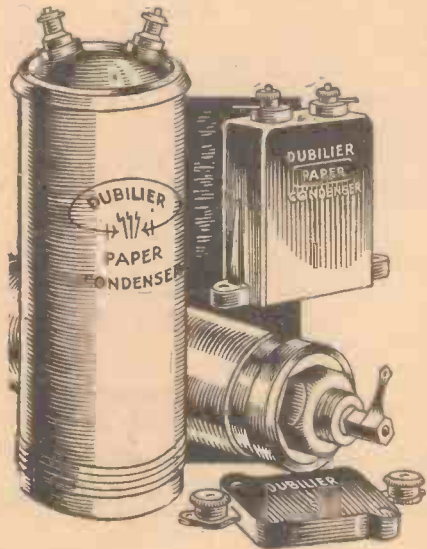

.. your first choice

Dubilier Condensers are repeatedly specified by Set designers and constantly used by manufacturers and constructors alike. They have an unrivalled reputation for dependability, are soundly constructed, and suitable types can be obtained for your every requirement. The use of a Dubilier Condenser is an assurance of good performance, lasting value and trouble-free reception.

Write for a free copy of the new Dubilier illustrated booklet.

DUBILIER

CONDENSER CO (1925) LTD

Ducon Works, Victoria Road
N. Acton - - London, W.3

RADIO CLUBS AND SOCIETIES

Club Reports should not exceed 200 words in length and should be received First Post each Monday morning for publication in the following week's issue.

SLADE RADIO

At a recent meeting of this society, Mr. Betteridge, of the Marconiphone Co., Ltd., gave an address upon "Latest Valve Developments." The lecturer gave thoroughly detailed and technical explanations of the latest types, and many of the circuits for which they were designed. Members were shown a number of valves in various stages of manufacture, and also special valves for microphones and deaf aid appliances. The society is going very strong, and meets every Thursday, at 8.15, at the Shakespeare and Dickens' Rooms, Edmund St., Birmingham. Hon. Secretary, Chas. Game, 40, West Drive, Heathfield Park, Handsworth.

SHORT-WAVE RADIO AND TELEVISION SOCIETY (THORNTON HEATH)

The Twelfth Annual General Meeting of this society was held at St. Paul's Hall, Norfolk Road, on Tuesday, September 24th.

In his opening remarks the Chairman, Mr. S. J. Meares, said that the society had had a satisfactory year and this was confirmed by the Hon. Secretary's report on the year's work, the main item of interest being the increase in membership.

The election of officers and committee then took place. Mr. S. J. Meares stated that for business reasons he did not offer himself for re-election as Chairman, and Mr. R. E. G. Copp was unanimously elected to fill this position. Mr. J. T. Webber and Mr. O. L. Crossley were again elected Hon. Secretary and Hon. Treasurer, respectively, and Mr. Wiltfield and Mr. Boddington as Auditors. The following members were appointed to the committee: Messrs. Meares, Clark, Hoare, Dabbs, Seal, and Lobb. The question of revision of the existing rules was discussed. The Hon. Secretary had drafted a new set of rules, which with some slight alterations were finally adopted.

The Hon. Secretary is Mr. Jas. T. Webber, of 368, Brigstock Road, Thornton Heath.

SHEFFIELD AND DISTRICT SHORT-WAVE CLUB

At the first meeting of the above society this season, Mr. Penkington, 49, Wade St., Fitts Moor, Sheffield, was re-elected President and Mr. D. H. Tomlin, Secretary. Commencing on October 2nd, a series of lectures are to be given on "The Fundamentals of Radio." This series is being given by Mr. Orress, 2AYB. Morse practice both fast and slow is given to members who desire it. A 50-MC field-day is to be held in the near future, possibly the third Sunday in October. All who wish to co-operate in this field-day should write to the secretary at the address given below. Donald H. Tomlin, Hon. Sec., 32, Moorsyde Avenue, Walkley, Sheffield.

WORKING MODELS

AND HOW TO MAKE THEM

By F. J. Camm

79 Simple and Fascinating Models described. Cover in Full Colour and hundreds of Sketches throughout.

A book for every boy.

Only 3'6 net

From All Booksellers

GEORGE NEWNES, LIMITED

PRACTICAL TELEVISION AND
SHORT-WAVE REVIEW

6d. MONTHLY

There was a young man
of Skegness
A Wireless - FIEND!
More or less!
All day he would tinker—
This clever young
thinker—
With FLUXITE and
GUN—no mess!



See that FLUXITE is always by you—in the house—garage—workshop—wherever speedy soldering is needed. Used for 30 years in government works and by leading engineers and manufacturers. Of Ironmongers—in tins, 4d., 8d., 1/4 and 2/8.

Ask to see the FLUXITE SMALL-SPACE SOLDERING SET—compact but substantial—complete with full instructions, 7/6.

Write for Free Book on the art of "soft" soldering and ask for Leaflet on CASE-HARDENING, STEEL and TEMPERING TOOLS with FLUXITE.

TO CYCLISTS! Your wheels will NOT keep round and true unless the spokes are tied with fine wire at the crossings AND SOLDERED. This makes a much stronger wheel. It's simple—with FLUXITE—but IMPORTANT.

THE FLUXITE GUN

is always ready to put Fluxite on the soldering job instantly. A little pressure places the right quantity on the right spot and one charging lasts for ages.



ALL MECHANICS WILL HAVE

FLUXITE

IT SIMPLIFIES ALL SOLDERING

FLUXITE LTD. (Dept. W.P.), DRAGON WORKS,
BERMONDSEY STREET, S.E.1

EASY WIRING



CLIX Chassis Mounting Valveholders of the 4, 5, 7 or 9-pin type are supplied with either Terminal or Soldered connections.

SPECIFIED
for the
1936
SUPERFORMER

The centre socket of the 5-pin and two sockets of the 7-pin type are made longer than the others: this reduces the possibility of short-circuits and adds to the ease of wiring.

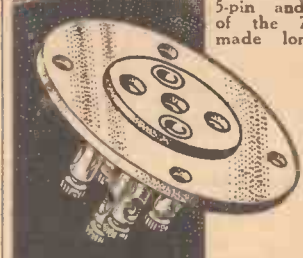

4-pin - 8d.
5-pin - 9d.
7-pin - 1/-
(with terminals!)

CLIX

CLIX also Specified for ALL apparatus described in the SHORT-WAVE HANDBOOK Free with this issue.

Two New Illustrated Folders "N" Free on request.

LECTRO LINX LTD.

79a, Rochester Row, London, S.W.1.

REPLIES IN BRIEF

The following replies to queries are given in abbreviated form either because of non-compliance with our rules, or because the point raised is not of general interest.

T. E. C. (Lancaster). The trouble is probably due to the method of tuning, and you give no particulars regarding this.

R. S. (Rochdale). The receiver was described in a contemporary, and we are sorry that we have had no experience with it.

D. H. (Clifton, Bristol). The indication is that either the H.T. has run down or is of too low a value, or that the output valve is defective. The valve should not be operated without grid-bias. The earth wire in question may be held in position with adhesive tape, and a portion of cold solder or similar material may be used to ensure good contact.

S. J. P. (Enfield). The coils should be ganged, and the T.D.S. coils should be adapted for use if desired. The reactor could not be employed without completely modifying the remainder of the circuit.

R. J. (Edinburgh). We cannot trace the coil reference, and are inclined to think that you have made a mistake in the letters. Can you verify the number?

J. S. (Midlothian). The indication is that the set is unstable when all circuits are correctly lined up. The instability may be due to wrong operating voltages or to interaction between components or wiring. These are the points which should therefore receive your attention.

F. W. H. H. (Bloemfontein, O.F.S.). There is no weekly publication which gives the details you ask for. The "Guide to Amateur Radio" might help, but probably a local magazine is to be more relied upon in view of the local knowledge.

D. H. (Horton). Your point is not quite clear. When you refer to the H.F. stage not working and the set only being made to oscillate faintly, do you imply that the oscillation obtained from the detector-reaction circuit is only faint, or that the H.F. stage produces oscillation? In the latter case, of course, the H.F. stage is unstable, and that is the cause of the poor results. If the reaction will not function it indicates either that the extra load on L.T. or H.T. prevents the valves from receiving correct working voltages, or that a short-circuit is introduced. The addition of the H.F. stage should not affect the working of the detector stage.

W. J. A. (Gloucester). We have no blueprint of a receiver using the valve you mention. There are several receivers in which valves of that type could be used, but it is necessary to have further details of your requirements before one can be specified.

P. A. M. (Co. Durham). We are sorry that we have no details of the coil in question, and cannot, therefore, recommend a circuit for it.

J. P. (Pantyridd). The dots are no indication of the type of the coil, and some reference number is required in order that they may be identified. The makers are no longer producing wireless components, and we do not think they will be able to assist you.

C. E. B. (S.W.3). It would be possible to use an ordinary triode valve, but the amplification would be very much less. Simply wire the receiver as given in the issue in question, and ignore the H.T. lead to the fifth terminal on the second valveholder. You can then plug in your triode and the receiver will function satisfactorily.

D. R. H. (Gillingham). The trouble is quite common and is due to the interaction between the mike and speaker. The microphone must be arranged so that the sound waves from the speaker do not strike the microphone, and with many makes it is quite sufficient to turn the microphone round so that it presents its back to the speaker when the two have to be arranged close together. The undistorted output of the P.T. 625 is 1 watt.

T. J. W. (Ystrad Myhach). The A.C. Three was the only receiver in which the coils in question were employed, and perhaps this will suit your requirements. There are no circuits using the 4-volt eliminator arrangement you refer to, and the set above mentioned does not employ the valves you name.

A. O. W. S. (N.13). The case referred to was an actual occurrence and tends to indicate that either the point in question was earthed, or that the mains were faulty. We will go into the question.

A. A. (Caithness). A full list of components is given in the constructional article, and was repeated in our issue dated November 3rd, 1934.

J. N. A. (C.G. 1817). It would appear that there is a faulty component in the circuit, and as a triode functions the fault must arise in the diode circuits. Can you check these?

G. A. B. (Maida Vale). We are sorry we cannot help you. You do not state the type of receiver, and Messrs. Telsen supplied various types from time to time. The coils might prove useful, but probably the remaining components are sufficiently out of date to warrant scrapping.

R. P. (Falkirk). The trouble is simply that you are endeavouring to push reaction too far. You have reached the limit with the receiver as it stands and more powerful apparatus would be required to obtain the signals at louder volume.

R. R. (Barnsbury). Any good modern valves may be used. The three types are detector, L.F., and small power.

S. B. (Salford, 5). We regret that we have no details now. The issues are out of print, and no records exist of these particular coils.

VITAL NEWS FOR EVERY KEEN CONSTRUCTOR...

... the House of **BULGIN**



- Circuits include —
- No. 1. 3-Valve Battery Q.P.P. Set.
 - No. 2. 5-Valve A.C.-D.C. Superhet.
 - No. 3. A.C.-D.C. Short-Wave Converter.
 - No. 4. 10-watt A.C. Amplifier.
 - No. 5. Short-wave Superhet with the S.W.22 chassis.
 - No. 6. Four Range A.C.-D.C. 5-Valve Superhet.
 - No. 9. 5-watt D.C. Amplifier.
 - No. 10. Midget self-contained portable.

Stations of the World map with station chart and log.

Stations of Europe map. Fully illustrated with photographs, lay-outs and wiring circuits and diagrams.

introduce **10 TESTED CIRCUITS** that finally solve the problem of "what to build"

Big performance sets for every interest and every purse, backed by a name as old as radio itself.

PRICE **1/-** POST FREE

At its price of only one shilling this expertly compiled Bulgin publication represents really incredible value. Don't delay. Tear out, fill in, and post coupon NOW.

SEND THIS COUPON NOW!

To: Dept. N., A. F. BULGIN & Co., Ltd., Abbey Rd., Barking, Essex.

Kindly send, post free, a 40-page copy of "Radio Progress." I enclose 1/- postal order or stamps.

NAME

ADDRESS

REF. A

SHOWROOMS:—64, HOLBORN VIADUCT, LONDON, E.C.1.

For a good job well done

BELLING-LEE FOR EVERY RADIO CONNECTION



Multiple Connector. No. 1251. 3s. 6d.

Stand-Off Bushing. No. 1224. 1s. 6d.

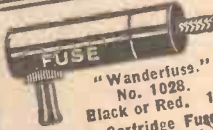

"Wandertuss." No. 1028. Black or Red. 1s. Cartridge Fuses. All ratings and sizes. one price: 6d. each.

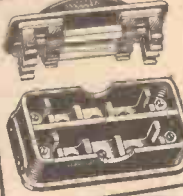

Twin-Safety Fuseholder. No. 1033. 2s. 6d.



"B" Type Terminal. No. 1001. 6d.

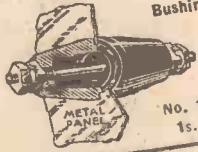

Stand-Off Insulator. No. 1222. 1s. 2d.

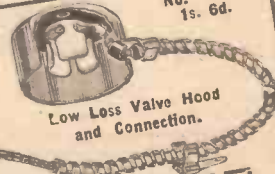

Low Loss Valve Hood and Connection. No. 1224. 1s. 6d.

BELLING & LEE LTD CAMBRIDGE, NOTTINGHAM ROAD, ENFIELD, MIDD.

Please send, free, your 36-pp. Catalogue, "Radio Connections."

Name

Address

Pr. W. 12.10.35.....

LET OUR TECHNICAL STAFF SOLVE YOUR PROBLEMS

Queries and Enquiries

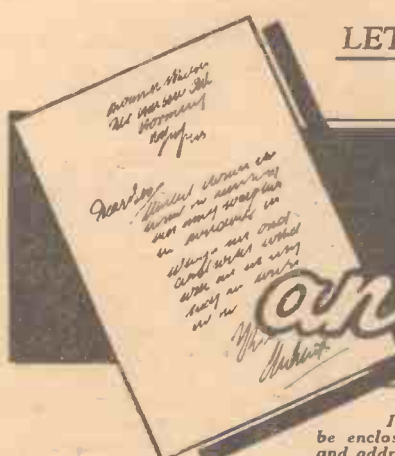

If a postal reply is desired, a stamped addressed envelope must be enclosed. Every query and drawing which is sent must bear the name and address of the sender. Send your queries to the Editor, PRACTICAL AND AMATEUR WIRELESS, Geo. Newnes, Ltd., 8-11, Southampton Street, Strand, London, W.C.2.

The Speaker Field

"I have an eliminator supplying H.T. to my set which consumes all the current delivered by the 60 ma. rectifying valve. I now wish to use an energised speaker and the eliminator has a built-in L.F. choke of 2,000 ohms. I intend to remove this and use the field of 2,000 ohms in its place. Will this only pass the current required for my set in the same manner as the choke, or will it consume any current and thereby rob the set of the necessary current and voltage? I am assuming that the field will only pass the current in the same manner as my existing choke as they are of the same resistance, and that it will not consume any current in creating a magnetic field."—W. D. (Davyhulme, Manchester).

AS the choke and field are of the same D.C. resistance, the current flowing through each at the same applied voltage will be identical. Therefore, the substitution of the speaker field for the choke will make no difference whatever to the output from the eliminator. There is, however, another point to be borne in mind and you have not mentioned this. We refer to the wattage dissipation across the field which is required for correct working. You may find, for instance, that the speaker in question, although having a 2,000 ohm field requires an energising wattage of, say, 20 watts, which means that a current of 100 milliamps must be passed through it for full energisation. At 60 ma. the wattage developed across the field will be 7.2, and provided this gives ample strength in the gap (which will depend upon the make of speaker) the arrangement is perfectly satisfactory.

Making Your Own Coils

"In the article on making your own coils you do not give the dimensions of the coil former, merely stating that they may be bought. Could you please inform me on this point as I wish to make these in view of the high cost of components in this country, and thus home-made components are really appreciated by us here?"—N. McL. (Siakot, Punjab).

THE coil formers in question had an external diameter of 1½ in. and an overall length of 2½ in. The components specified were made from paxolin, but ebonite could be used, or formers could be made up by wrapping good quality brown paper round a suitable wooden former and carefully smeared with glue as the turns are wrapped on. In this manner a really strong tube could be made up.

A Mains Transformer Query

"I have just completed the A.C. Century Super. I tried it last night and the tone is

SPECIAL NOTE

We wish to draw the reader's attention to the fact that the Queries Service is intended only for the solution of problems or difficulties arising from the construction of receivers described in our pages, or on general wireless matters. We regret that we cannot, for obvious reasons—

- (1) Supply circuit diagrams of complete multi-valve receivers.
- (2) Suggest alterations or modifications of receivers described in our contemporaries.
- (3) Suggest alterations or modifications to commercial receivers.
- (4) Answer queries over the telephone.
- (5) Grant interviews to querists.

Please note also, that queries must be limited to two per reader, and all sketches and drawings which are sent to us should bear the name and address of the sender.

beautiful, but reception weak. In your accessories you specify one Heayberd type 717 mains transformer, 250-0-250 volts 60 mA ; 2-0-2 volts 1 amp., 2-0-2 volts 6 amps. On the blueprint you show a transformer 4v. 1 amp., 4v. 6 amps. I had to send to Heayberds direct to get the transformer, and they have sent me a 250-0-250 volt 60 mA, 4v. 1 amp., 4v. 6 amps. type 717. Is this the right one, or is it the reason for the poor reception?"—W. W. (Belfast).

THE transformers you mention are all identical. The H.T. winding is the same in each case as you see, but the L.T. windings must be of the 4-volt type. These latter windings, however, are provided with a centre tap, as the rectifier heater winding, for instance, utilises its centre tap for the H.T. positive lead, and the centre tap on the other windings is joined to earth in order to remove hum. Consequently, as there are 4 volts required across the total winding, and there is a centre point, the voltage on each side of the latter point will be 2 volts. Thus the usual method of showing that a 4-volts winding is available with a centre tap is to write it as 2-0-2 (the 0 representing the centre point, or zero as it is an alternating current supply), or 4 volt C.T. We trust this is now clear. The amperage of the winding is usually indicated to enable the approximate gauge of wire to be ascertained and in general you may consider that each valve takes 1 amp., and, therefore, should use a winding rated at an amperage equalling the number of valves. Most good transformers will supply approximately 50 per cent. more valves than the rating, however, without a serious voltage drop across the winding.

A Wave-trap Required

"I have built a three-valve set with S.G., detector and pentode valves. I get good reception, but there are a few stations which

I cannot get very well. For instance, when I tune to — I always get Droitwich in the background. I should like your advice on the matter."—R. B. P. (Higham Ferrers, Northants).

WE think your troubles are actually due to the fact that you are situated close to the high-powered Droitwich station. With a receiver of the type you name it would be very difficult to tune to the station mentioned without hearing Droitwich as a background, and you would need a superhet circuit to guarantee clear reception of that station. In your case, we think the situation could be met by fitting a special wave-trap or Droitwich Suppressor in the aerial circuit so that that station would be kept within bounds. No doubt, a local radio dealer will have one of these components in stock.

Interference from Trams

"I have a five-valve AC/DC receiver, but owing to the local trams which pass my house, and other electrical apparatus which is situated near at hand, I find great difficulty in receiving foreign programmes without interference. I should be very pleased if you would inform me how to cure this annoyance for certain, as I do not wish to spend money on some device that may not work."—R. H. (Finchley).

GENERALLY speaking, interference from the tramway system can only be cured by the tramway company. However, you will no doubt find that by erecting an aerial in a certain position (found by trial) and using one of the screened downleads with an impedance matching device at each end, you will be able to reduce the interference to such a level that distant reception can satisfactorily be carried out, although probably there will be some loss of signal strength. The recent articles on interference and noise-free aerial systems will, no doubt, have been of interest to you in this connection.

Meter Magnets

"I should be glad if you could inform me where I could obtain small horse-shoe permanent magnets such as those used in a moving-coil meter or pick-up."—J. C. H. (Bradford).

THE magnets in question may be obtained from Darwins, Ltd., Fitzwilliam Works, Sheffield, or from Swift-Levick and Sons, Ltd., of Clarence Steel Works, Sheffield 4.

The coupon on cover iii must be attached to every query.

Miscellaneous Advertisements

Advertisements are accepted for these columns at the rate of 3d. per word. Words in black face and/or capitals are charged double this rate (minimum charge 3/- per paragraph). Display lines are charged at 6/- per line. All advertisements must be prepaid. All communications should be addressed to the Advertisement Manager, "Practical and Amateur Wireless," 8, Southampton Street, Strand, London.

RECEIVERS, COMPONENTS AND ACCESSORIES

Surplus, Clearance or Secondhand, etc.

PREMIER SUPPLY STORES

ANNOUNCE a City Branch at 165 and 165a, Fleet Street, E.C.4 (next door to Anderson's Hotel), for the convenience of callers; post orders and callers to High Street, Clapham.

OFFER the following Manufacturers' Unused Goods at a Fraction of the Original Cost; all goods guaranteed perfect; carriage paid over 5/-, under 5/-, postage 6d. extra. L.F.S. and abroad, carriage extra; orders under 5/- cannot be sent C.O.D.; please send 1d. stamp for large new illustrated catalogue, also October bargain supplement.

WORLD Famous Continental Valve Manufacturer; mains types, 4/6 each, H.L., L. power; high and low magnification, screen grid; variable Mu screen grid; 1, 3, and 4 watt A.C. output, directly heated pentodes; V.H.P., D.D.T. Diode Tetrodes, 250 volt 60 m.a. full wave rectifiers; A.C., D.C. types, 20 volts, 0.18 amp. filaments; screen grid; variable Mu screen grid; H., H.L., power and pentodes.

THE following Types, 5/6 each; 350v., 120 m.a. full wave rectifiers, 500v., 120 m.a. full wave rectifiers, 2½ watt indirectly heated pentodes. 2-VOLT H.F., L.F., 2/3; power, low consumption mu screened grid, 5- or 4-pin pentodes H.F. Pen., V.M., H.F. Pen., 3/-.

THE following American Types, 4/6; 250, 210, 245, 47, 46, 24, 35, 51, 57, 55, 55, 37, 80, 6A7, 2A7, 27, 77, 78, 2A5, 281. All other types, 6/6.

B.T.H. Moving Coil Speakers, matched pairs, 8in., 1,500 ohms, 7,500 ohms (1,500 speaker as choke 7,500 speaker in parallel with H.T. supply), with output transformer for pentode, 15/6 per pair; A.C. kit for pair, 12/6.

M.C. Multi-ratio output transformers, 2/6; 2-1 or 1-1 output transformers, 2/6; microphone transformers, 50 and 100-1, 2/6; 3 henry chokes, 2/6; 100 henry chokes, 2/6.

A LARGE selection of Ecclesdale, table and radio-gram cabinets at a fraction of original cost.

BLUE-SPOT 29P.M., P.M. Moving Coil multi-ratio transformers, 15/-; handles 4 watts. Sono-chorde ditto, 10/6.

ELIMINATOR kits, condensers, resistances and diagrams, 120v. 20 m.a., 20/-; triacle charger, 8/- extra, 150v. 30 m.a. with 4v. 2-4 amp. C.T., L.T., 25/-; triacle charger, 6/8 extra; 250v. 60 milliamps, with 4v. 3-5 amps., C.T., L.T., 30/-; 300v. 60 m.a. with 4 volts 3-5 amps., 37/6; 200v. 50 m.a., with 4v. 3-5 amps. L.T., 27/6.

PREMIER L.T. Charger Kits, Westinghouse rectifier, input 200-250v. A.C. output 8v. ½ amp., 14/6; 8v. 1 amp., 17/6; 6v. 2 amp., 27/6; 30v. 1 amp., 37/6; 2 v. ½ amp., 11/-.

B.T.H. Trusped Induction Type A.C. only, Gramophone Motors, 100-250v., 30/- complete; ditto, D.C., 42/6.

COLLARO Gramophone Unit, consisting of A.C. motor 200-250v. high quality pick-up and volume control, 45/-; Motor only, 35/-.

DISON BELL Double Spring Gramophone Motors, complete with turntable and all fittings, 15/-.

WIRE Wound Resistances, 4 watts, any value up to 50,000 ohms, 1/-; 8 watts, any value up to 50,000 ohms, 1/6; 15 watts, any value up to 50,000 ohms, 2/-; 25 watts, any value up to 50,000 ohms, 2/6.

MAGNAVOX 144, 15/-; 144 Magna, 25/-; 152, 17/6; 152 Magna, 37/6, 154, 12/6, Dual-Matched Pairs D.C. 144/152, 32/6. Ditto Magna, 62/6. A.C. Energising Kit to suit any of above, 10/-, all 2,500 ohms. P.M. 7 inch, 16/6, P.M. 9 inch, 22/6. State transformer required.

12 TO 2,000 Metres without Coil Changing; huge purchase of Lissen all-band 2-gang screened coils, suitable for screen grid, H.F. stage (tuned) screened grid detector type receiver, complete circuit supplied, 12/6.

BRITISH made Meters, moving iron, flush mounting, B 0-10, 0-15, 0-50 m.a., 0-100, 0-250 m.a., 0-1, 0-5 amps., all at 6/-; read A.C. and D.C.

POTENTIOMETERS by Best Manufacturers, 200, 350, 500, 1,000, 2,500, 5,000, 8,000, 10,000, 15,000, 25,000, 50,000, 100,000, 250,000, 500,000, 1 meg., 2/-; 5,000, 10,000, 15,000, 100,000 with mains switch, 2/-.

1,000 OHM, 150 milliamp, Semi-variable resistance, 2/-; 1,000 ohm, 250 milliamp, tapped for any number .18 valves, 3/6; 800 ohms, 350 m.a., tapped, 2/-.

COSMOCORD pick-ups with Arm and Volume Control, wonderful value, 10/6.

THE following Lines 6d. each or 5/- per dozen. 4- or 5- pin baseboard of 4-, 5-, 6-, or 7-pin chassis mounting valve holders, American valve holders, 1

(Continued at top of column three)

The SHORT WAVE FAN'S Own MAGAZINE



No. 1 "The SHORT WAVE CONSTRUCTOR" ... packed full with short-wave articles of absorbing interest. Describes in detail 3 entirely new Short and Ultra-Short-Wave Circuits etc., etc. ... the very latest in short-wave technique. Obtainable through all branches of W. H. Smith and Sons, Radio dealers, or send 3d. direct to the Publishers:

B.T.S.—THE ACKNOWLEDGED LEADERS IN SHORT WAVES

SPECIFIED 1936 SUPERFORMER

B.T.S. COMPONENTS, again chosen for their reliability and undoubted superiority. Produced by specialists—preferred by experts.

- | | |
|---|-----|
| 1 B.T.S. Short Wave Tuning Condenser, .0002 mfd, Type TRC32 | 4 6 |
| 1 B.T.S. Differential Reaction Condenser | 2 6 |
| 1 B.T.S. L.F. Transformer Type L.T. 135 | 4 6 |

FROM ALL DEALERS



BRITISH TELEVISION SUPPLIES, LTD., BUSH HOUSE, Dept Pr.W., LONDON, W.C.2

ENGINEERS! ARE YOU EARNING LESS THAN £10 PER WEEK?

If so, you cannot afford to carry on without reading our 268-page Handbook. The book explains clearly and definitely many ways of carving out a successful career. Among other things it explains the Services of our unique Appointments Department, outlines Home-study Courses in all branches of Civil, Mechanical, Electrical, Motor, Aero, Wireless, "Talkie," Eng. Building, etc., and gives details of B.S.O., A.M.I.C.E., L.E.E., A.M.I.Mech.E., A.M.I.A.E., A.M.I.R.E., G.P.O., MATRIC., and all Exams. We alone Guarantee—"NO PASS—NO FEE." Whether you be an old hand or a budding apprentice, get this book to-day—FREE and POST FREE.



BRITISH INSTITUTE OF ENGINEERING TECHNOLOGY, 409, Shakespeare House, 29/31, Oxford St., London, W.1.

MISCELLANEOUS

ALCO Eliminators and Chargers. 4 H.T. taps, 20 m.a., 18/-; with charger, 25/-; charger alone, 7/8; ½ amp., 11/-; Westinghouse rectifiers. Years guarantee, details free. P. and D. RADIO, 1, Gooding Road, N.7.

(Continued from foot of column one)

watt resistance, wire end, every value; tubular wire end condensers, 1,500 volt, every value up to 0.5, 0.3 amp., 2- or 3-point switches, Cydon double trimmers, 6yds. Systoflex, 1, 1.5, 2 or 2.5 mm., 1 yd. 7-way cable, 9ft. resincoated solder, 6 yds. push-back connecting wire.

RELIABLE Soldering Irons, 200, 250 volts, .2 amps, 2/6 each.

PREMIER short-wave tuning condensers (S.L.F.) complete ceramic insulation, silver-sprayed brass vanes, noiseless pigtail, .00015, .00016, .0001, 2/9. Double spaced, .00005, .00015, .000025, 3/- each.

BRASS reaction condensers (S.L.C.) with integral slow-motion, 2/9. Mica condensers, .00002, .00005, 6d.

PREMIER short-wave coils with circuit, 4- and 6-pin type, set of 4, 13-170 metres, 4/-, for either type. Low-loss formers, 4- and 6-pigribbed, 1/4 inch diameter, 1/-; Short-wave valve holders, 4-, 5- and 7-pin, baseboard, 10d.; chassis, 6d.

ELECTROLYTIC Condensers T.C.C., 8mf. 440v., 3/-; 550v., 4/-; 35 mf. 50v., 1/-; 15 mf. 100v., 1/-; 15 mf. 12v., 1/-; Dubilier 4 or 8mf. 550v., 3/-; 8 plus 4 500v., 4/-; 60v. 50mf., 1/9; 12mf. 20v., 6d.

U.S.A. 4, 8, or 12mf. 550v., 1/9; 100 mf. 12v., 1/3; 2,000 mf. 12v., 6/-; 8+4 mf. 500v., 2/3; 4+4 mf., 2/-.

PAPER Condensers. Dubilier 4mf. 500v. working, 4/-; ditto 700v., 5/-; ditto, 800v., 6/-; Western Electric, 250v., working 1 mf., 9d.; 2 mf., 1/-; 4mf., 2/-; 1mf. 2,000 v., working, 3/-.

CONDENSER Blocks 250v. working various taps. 6mf., 2/-; 10mf., 3/-; 8.5mf., 2/8.

MAINS Transformers. Premier all have tapped primaries, C.T., L.T.'s and Engraved terminal Board. H.T.8 plus H.T.9, 2 L.T.'s, 10/-; Rectifier, 8/6 extra; H.T. 10, 2 L.T.'s, 10/-; Rectifier, 9/6 extra; 250 plus 250 60 m.a. 3 L.T.'s, 10/-; 350 plus 350 150 m.a. 3 L.T.'s, 12/6.

WESTERN ELECTRIC Manufacturers type 350 plus 350 60 m.a. 2 L.T.'s, 6/3; 350 plus 350 120 m.a. 3 L.T.'s, 9/6; 500 plus 500 150 m.a. 5 L.T.'s, 19/6.

VARIABLE condensers. Premier, all brass, short wave, .00015 slow motion, 3/9; British Radiophone, all brass, 2-gang, .00015 each section, 5/6; Ormond, .00025, 1/6; Polar, all brass, .0005 slow motion, 3/11; Lissen 2-gang, .0005, front trimmer, disc drive, 5/11; Utility 3-gang fully screened trimmers and disc drive, 7/6.

BAKELITE reaction condensers, .00015, .00035, .0001, .0003, .0005, 9d.

LISSEN 3-gang, superhet coils, 6/-; Iron core coils with circuit, 2/11 each; Varley band-pass aerial coils, B.P.5 type, 2/9; ditto band-pass transformer, B.P.3, 2/6.

H.F. Chokes Premier screened, 1/6; Premier short-wave, 9d.; pre-sets, any value, 6d.

PREMIER smoothing chokes, 25 m.a., 20 henries, 2/9; 40 m.a. 40 henries, 4/-; 60 m.a., 40 henries, 5/6; 150 m.a., 50 henries, 10/6; 60 m.a., 80 henries, 2,500 speaker replacement, 5/6.

PREMIER auto transformer 100/200-250 and vice versa, 100 watt, 10/-; 50 watt, 7/-.

CLARION S.M. drives, moving light, 2 inch knob for short waves, 2/-.

PREMIER SUPPLY STORES

20-22, High Street, Clapham, S.W.4. 'Phone: Macaulay 2381/2. Nearest Station Clapham North (Underground).

FREE GIFTS.—Save money. Obtain exceptional surplus bargain lists of guaranteed Bryce Mains Transformers and Condensers, etc., and how to obtain free gifts. Easy payments. Don't delay. Associated Mail Supplies (No. 6), 4, Ashland Place, Paddington Street, London, W.1.

THE following unused set manufacturers' Surplus; all goods guaranteed perfect; immediate delivery.

MAGNAVOX speakers, complete with hum-bucking coil, output transformers, etc. DC152 (9in. cone), 22/6. DC154 (7in. cone), 16/-; All with 2,500 or 6,500 ohms fields.

WESTINGHOUSE rectifiers, HTS, 9/6. HT9, 10/-; HT10, LT5, LT4, 10/9. Regentone transformers for HTS or HT9, with 4v. 4 amp. LT winding, 7/-; Eliminators, first-class make. Outputs 150v. 25 m.a., SG and Detector. AC type with Westinghouse rectifier 25/-; AC type with 5 amp. trickle-charger, 30/-; DC type, 12/6.

DUBILIER or TTC dry electrolytic condensers 8mfds, 10v., 3/3. 50mfds, 15v., and 15mfds, 100v., 2/3. 50mfds, 12v., 2/-; TCC type "M" condensers, any value up to .001 mfd. 6d. Erie resistances, 1 watt type, 7d., 2 watt, 1/2, 3 watt, 1/9. Send for comprehensive list.

WARD, 46, Farringdon Street, London, E.C.4. Telephone: Holborn 9703.

BURGOYNE CLASS B-3

Limited stocks of this very fine Class B 3-valve receiver. All guaranteed new complete with Mullard Valves, Exide Accumulators and Batteries, Moving-coil Speaker, Cabinets Black and Chromium or Walnut. In sealed cartons, unopened; listed 26/18, our price 23 carriage paid. Cash refunded if not satisfied within seven days. G. W. RADIO, 7, Chapel Street, Lamb's Conduit Street, London, W.C.1. 'Phone: Holborn 4434.

RADIO CLEARANCE,
63, HIGH HOLBORN, W.C.1.
Tel. :—HOLBORN 4631.
THE ONLY RELIABLE MAIL ORDER HOUSE
IN THE TRADE.

Owing to increase of business we have found it necessary to remove to larger and more spacious premises at number 63, High Holborn. All orders in future should be sent to this address.

145/- BUSH (GAUMONT BRITISH PRODUCT) 5-VALVE A.C. 200/250 SUPER-HET SET, incorporating Fluid Light Tuning, A.V.C., and Mullard Valves. Handsome designed Cabinet, brand new in cartons. List price 12 Guineas. H.P. Terms can be arranged on application.

130/- BUSH (GAUMONT BRITISH PRODUCT) 4-VALVE A.C. 200/250 SUPER-HET SET, complete with Mullard Valves, handsome designed Cabinet, brand new in cartons. List Price 11 Guineas. H.P. Terms can be arranged on application.

130/- GROSVENOR 4-VALVE A.C. 200/250 Volts, incorporating Mullard Valves, Moving Coil Speaker, in handsome designed Cabinet, brand new in cartons. List Price 12 Guineas. H.P. Terms can be arranged on application.

85/- GROSVENOR 3-VALVE SCREEN GRID DETECTOR PENTODE BATTERY SET, hand pass tuned, incorporating Mullard Valves, Permanent Magnet Moving Coil Speaker, in handsome designed Cabinet, brand new in cartons. List Price 9 Guineas. H.P. Terms can be arranged on application.

135/- VOLTS SUPERHET SET incorporating Fluid Light Tuning, A.V.C., Mullard Valves, Energised Moving Coil Speaker, in handsome designed Cabinet, brand new, boxed. List Price 13 Guineas. H.P. Terms can be arranged on application.

15/11 3-VALVE SCREEN GRID DETECTOR, POWER BATTERY CHASSIS, incorporating 2-gang air spaced Condenser, canned coils, less Valves. A wonderful bargain.

15/11 LISSEN POWER PACKS, Input 100/250 Volts, Output H.T. 250 Volts 60 m.a., L.T. 4 Volt 4 amps, completely assembled in metal case for use with any 4 Volt 1 Amp Rectifying Valve. Brand New in cartons.

7/6 LISSEN GANGED SUPERHET COILS incorporating Aerial Coil, H.F. Coil and Oscillator Coil, 126 kc/s, fully screened with Switch, brand new and boxed.

3/6 BRITISH RADIOPHONE 2-GANG SHORT-WAVE CONDENSERS, .00016 per section, all brass vanes on Steatite Base.

9/6 CLARION PICK-UPS in moulded Bakelite case, very efficient. Listed 1 Guinea.

3/6 BRITISH RADIOPHONE SET OF SUPERHET COILS, including 110 kc/s Oscillator Coil, screened; Band Pass long and short-wave coils, unscreened.

5/11 UTILITY 3-GANG SUPERHET MIDGET TYPE CONDENSERS with 110 kc/s Oscillator Section fully screened.

5/11 UTILITY 3-GANG STRAIGHT MIDGET CONDENSERS, 3 .0005 Sections, fully screened.

2/11 BRITISH RADIOPHONE 3-GANG SUPERHET CONDENSERS, with 110 kc/s Oscillator Section, unscreened. A Wonderful Bargain.

4/6 HOME MICROPHONES. An efficient American Model for use with Receiver.

2/6 8 & 4 MFD. ELECTROLYTIC CONDENSERS by well-known Manufacturer, 450 volt working, 500 volt Peak, brand new.

2/3 50 MFD. 50 VOLT WORKING ELECTROLYTIC CONDENSERS in cardboard containers with wire ends by well-known Manufacturer.

1/3 50 MFD. 12 VOLT WORKING ELECTROLYTIC CONDENSERS by well-known Manufacturer.

1/- 2 MFD. 200 VOLT WORKING ELECTROLYTIC CONDENSERS by well-known Manufacturer.

1/- 4 MFD. 200 VOLT WORKING P.O. CONDENSERS. Very efficient.

6d. TUBULAR CONDENSERS, all sizes up to .1 mfd. by well-known Manufacturer.

6d. 1 WATT RESISTANCES, all sizes, by well-known Manufacturer.

5/- SPECIAL OFFER 1 gross box assorted all good sizes 1/2 Watt Resistances by Plessey.

1/6 BLOCK CONDENSERS, 4+2+1 mfd. 350 volt Working.

1/- BLOCK CONDENSERS, 1+1 mfd. 350 volt Working.

6/- H.T.8 MAINS TRANSFORMER by Standard Telephones and Cables, Input 200/250 volts, Output 250 volts 60 m.a., 4 volts 4 amps.

14/6 H.T.8 MAINS TRANSFORMER as above, complete with H.T.8 Rectifier.

4/6 LISSEN HANDSOME WALNUT TABLE CABINETS with provision for Speaker, cut out front, made for Lissen Band-pass 3 Kits. A wonderful Bargain.

3d. 5-PIN PLESSEY CHASSIS MOUNTING VALVE HOLDERS.

2d. PLESSEY 4-PIN CHASSIS MOUNTING VALVE HOLDERS.

All Orders under 10/- must be accompanied by a reasonable amount for postage.

Send us your orders and avoid being dissatisfied.

RADIO CLEARANCE,
63, HIGH HOLBORN, W.C.1.
Tel. :—HOLBORN 4631.

EASY TERMS

We specialise in the supply of all good quality Radio sets, components and accessories. Send list of requirements and keen quotation will be sent promptly. Cash or C.O.D. orders despatched by return of post. Price lists FREE.

VALVES

Screened Grid, Detector and Power, any make. Cash Price £1/5/0, or 5/- with order and 5 monthly payments of 4/6. Every type of A.C. Battery or Universal valve supplied on easy terms.

H.T. ELIMINATOR

with trickle charger.

ATLAS T.10/30 (30 millamp.) Cash price £3.9.6, or 5/- with order and 12 monthly payments of 5/11.



Heayherd Products supplied on similar terms.

Revitalise your set with a
1936 STENTORIAN

MODEL 36 S. Cash Price £2.2.0, or 2/6 with order and 11 monthly payments of 4/-.

MODEL 36 J. Cash Price £1.12.6, or 2/6 with order and 11 monthly payments of 3/-.

ROLA SPEAKERS

Similar Terms. Illustrated List Free.

New B.T.H. Piezoelectric Pick-up (giving finest possible gramophone reproduction). Cash price £2.2.0, or 6/- with order and 8 monthly payments of 5/-.

Garrard Electric Motor. Model AC-6. Cash price £2.2.6, or 5/- with order and 8 monthly payments of 5/3.

PROMPT DELIVERY. CARRIAGE PAID.

Estd. 1925 THE PHONE NATIONAL 1977

LONDON RADIO SUPPLY COMPANY

11, OAT LANE, NOBLE STREET, LONDON, E.C.2

Engineers' Guide

containing the widest choice of engineering courses in the world

Outlines The T.I.G.E.'s up-to-date home-study Courses in Wireless, Electrical and Mechanical Engineering, etc. Shows how to become A.M.I.E.E., A.M.I.W.T., A.Rad.A., etc., and how to qualify for a well-paid post. Training until Successful Guaranteed. WRITE NOW for Free Guide. THE TECHNOLOGICAL INSTITUTE OF GREAT BRITAIN, 42, Temple Bar House, London, E.C.4. (Founded 1917. 19,000 Successes.)



To Success

Constant Speed, Low Consumption, One Hole Fixing.

SIMPSONS ELECTRIC TURNTABLE

Obtainable at all 42/- Write for illustrated Radio Dealers. treated leaflet.

KINGSWAY RADIO, 3-9, Dane Street, High Holborn, W.C.1



RECEIVERS, COMPONENTS AND ACCESSORIES
Surplus, Clearance or Secondhand, etc.

SOUTHERN RADIO'S WIRELESS BARGAINS. ALL GOODS GUARANTEED NEW, PERFECT and SENT POST PAID.

FOX INDUSTRIAL 4-Valve Amplifiers. A.C. Mains. 3 1/2 Watt Output with two tuning coils. For Television. Radio, Gramophone and Microphone Chassis Complete, less valves, 30/-. With four specified Mullard Valves, £3 12s. 6d. Specified Speaker for same, 15s.

SPEAKERS.—BLUE SPOT 1935 Series with Universal Transformers to suit any circuit. 90P.M., 24/6, 45 P.M., 20/-, 90P.M. (Extension Model, less transformer), 21/-. Celestion Soundex, 11/- ALL IN SEALED CARTONS.

LISSEN 2-Valve Sets for D.C. Mains. Complete with Speakers and Valves. Contained in attractive Bakelite Cabinet, £2 10s. (List, £3) in sealed cartons.

LISSEN Skyscraper 3-Valve Screen Grid Battery Kits. Complete with 3 Lissen Valves, in sealed cartons, 42/- each (77/6 list).

BURGOYNE CLASS "B" Three-Valve Sets. Complete with three Mullard Valves. Exide Batteries and Accumulator. Magnavox Moving-coil Speaker. Contained in magnificent modern cabinet. Flushed in chromium. 1935 Series, £2 15s. Complete (List, £6 10s.). In sealed cartons.

MIDGET SETS.—"Lucille" 1935/36 Series A.C./D.C. Universal Sets for 100/250 Volts. Medium and Long Waves. 5 Valves complete with moving-coil Speaker in beautiful walnut cabinet. £3 19s. 6d. Similar Model for Medium Waves only, £3 10s.

ELIMINATORS.—Regentone 1935 Series. A.C. Mains, 200/250 Volts, Type W5a, complete with trickle charger, 39/6; W1a (less Trickle charger—carries 30 millamps), 33/-; W1c (less trickle charger), 30/-. All in sealed cartons.

CONDENSERS.—Lotus 0.0005. Fully screened, with trimmers, escutcheons, dials and knob. 3-gang, 11/-, 2-gang, 7/3. TELSEN SINGLE VARIABLE CONDENSERS, 0.0005, 2/3; Plessey 4-gang Super-het, fully screened with trimmers, 7/3. Igranite, 1 mfd., 1/3, 2 mid., 1/0. LISSEN HYPERNIK-TRANSFORMERS: 4:1 ratio, 3/11 (List, 12/6).

COILS.—Telsen Intermediate frequency transformers. Type W4S2, 4/-; Igranite Super-het. Coils, set of four (1 Osc., 2 I.F. with pigtails, 1 I.F. plain), 9/- per set (List, 50/-). Varley Square Peak Coils, B.P.S. complete, 2/3.

THE following Telsen Components in original sealed cartons at sacrifice prices:—
ACE L.F. TRANSFORMERS—5/1, 2/0; Binocular H.F. Chokes, 2/-; Standard Screened H.F. Transformers, 5/- each. This Microphone can be used with any radio set and is a very efficient article.

AMERICAN VALVES.—A full range of valves for all American sets at 7/- per valve.

SOUTHERN RADIO BARGAIN PARCELS.—We are offering the following parcels of mixed components at a fraction of their value. The items comprise up-to-date Radio parts, new and perfect, which are too varied to be advertised individually:—

5/- PARCEL.—Contains modern components valued at 20/-, including Resistances, Condensers, Coils, Wire, etc. Circuits of modern Receivers included with each parcel.

10/- PARCELS.—Containing components valued at 45/-, including Volume Controls, Condensers, etc., also circuits.

20/- PARCELS.—This is known as the "small trader's" parcel, and contains a wonderful selection of components valued at 85/-. We have supplied this parcel to hundreds of Traders for re-sale at a profit.

SOUTHERN RADIO 323, EUSTON ROAD, LONDON, N.W.1 (near Warren Street Tube). 'Phone: Museum 6324.

SOUTHERN RADIO, Branches at 271-275, High Road, Willesden Green, N.W.10: 46, Lisle Street, W.C.2. All Mail Orders to 323, Euston Road, London, N.W.1.

CAMM'S 1936 SUPERFORMER. Complete specified Kit, lowest price for CASH, C.O.D. or Easleway. Lists free. Kits, Receivers, Components, etc., (lowest prices always. Melfo-Rad, Queen's Place, Hove (trade supplied).

SPECIAL OFFER.—Cossor Model 950 1935 Battery Receivers, 3-Valve Screen Grid, complete with valves and built-in Speaker. Finest Foreign Station getting set on the market.

X X.—Our Special net price £3 10s. each, very limited number only.

X X.—Order early to avoid delay.

X X.—Midway Radio Exchange, 6, Pentonville Road, London, N.1. 'Phone Terminus 6751.

V AUXHALL.—Station named scales for "Polar" Horizontal dials, the latest settings thereon, 1/9 each.

V AUXHALL.—All goods advertised previously still available; immediate delivery; drawings and queries answered free.

V AUXHALL UTILITIES, 163a, Strand, London, W.C.2. Temple Bar 9383; and at 56, Ludgate Hill, E.C.4.

RECEIVERS, COMPONENTS AND ACCESSORIES (Secondhand)

EXPERIMENTER'S OPPORTUNITY. Parcels containing Wireless Components, 40/- value for 5/6, Carriage 1/-. Taylor's, Radio House, Macaulay Street, Huddersfield.

CLARION VALVES.—All brand new; battery types, 2-volt, H.2, HL.2, LP.2, 1/9; super power, P.2, 2/6; screens and pentodes, 3/9; A.C. mains, 4-volt, 1-amp., general purpose, 3/3; power, 4/-; screens and pentodes, 4/6; full-wave rectifiers, 3/6; postage paid, cash with order, or C.O.D. over 10/.

BANKRUPT bargains. List free. Burgoyne 3v. sets, complete, 42/-. Amplion 5v. A.C. and ACE 5v. universal receivers, keenest prices. Lissen D.C. 3v. S.G. sets. M.C., 69/6. Large stock valves, speakers, eliminators, etc. Anything radio. Part exchange. American and mains valves from 3s. 6d. Butlin, 143b, Preston Road, Brighton.

WOUBURN RADIO OFFER FOLLOWING NEW LINES:
W.R.C. SHORT WAVE COILS: 4-pin plug in to 4-pin valve-holder, 10-22, 20-45, and 42-90 metres, set of three 7/6, singly 2/8.
W.R.C. Short-Wave Chokes, 10-100 metres 10d.

W.R.C. Short-Wave condensers, .0001, .00015, .00016, .0002, .00025, .0003, all with slow motion, 2/-, two-piece Ormond slow motion dial to fit, 1/-.
WESTINGHOUSE H.T.8 and 9, 8/6. Popular iron cored dual range coils, 2/6. L.F. Transformers, 5/1 and 3/1, 2/6. Mike Transformers, ratio 100/1, 2/6. Differentials .0001, .00015, .0003, 1/4. Tubular, 1, .01, and .02, 6d. Eric resistances, all values, 6d. each. Radiophone, piano type, three gang, .0005, superhet condensers, with top trimmers, few only, 6/-.
W.R.C. Eliminators. Guaranteed 12 months. 150v., 30 m.a. Three positive H.T. Tappings. Westinghouse Rectifiers. A.C. Model, 21/- carr. 9d. A.C. model, with trickle charger, 2 v., 4 v., or 6 v. 1/2 amp. 32/6, carr. 1/-.

TRADE List ready. Send trade heading and stamp.
WOUBURN RADIO CO., 9, Sandland Street, Holborn, W.C.1.

HULBERT for Quality Surplus Speakers.
HULBERT. All speakers previously advertised still available. All are brand new and made by one of the best-known British makers of high-grade moving-coil speakers. Prices from 10/6. All Music lovers interested in realistic reproduction should write for list of amazing bargains. Repeat orders are coming in daily.
HULBERT, 6, Conduit Street, W.1.

CLEARANCE Bargains, B.T.H. 2,500 speakers, 7/9. Western Electric microphones, 1/4. B.I.C. 8 mfd. 550 Peak Electrolytic Condensers, 2/- each, and 500 other lines. Catalogues 3d. each. All orders 4/- and over post free.
J. BEARFIELD, 105, Upper St., London, N.1.

NEW RECEIVERS, COMPONENTS, and ACCESSORIES

30/- SHORT-WAVE ONE VALVE-CONVERTER - ADAPTORS. — Guaranteed. Plug in to make your present mains or battery set **ALL-WAVE.** S.W. Kits 20/-. Order from: Bennett Television Co., Redhill.

FERGUSON Universal Midget Receiver for AC/DC. 100-250 Volts. Moving Coil Speaker. Wonderful tone and outstanding selectivity. Limited number. 65/- Car. Paid. Send for latest list, hundreds of other Bargains. Pearl and Pearl, 100, Bishopsgate, London, E.C.2.

OUR CATALOGUE SAVES POUNDS BUT COSTS ONLY STAMP.

THE SQUARE DEALERS RADIOMART, 19, JOHN BRIGHT STREET, BIRMINGHAM.

ALL-WAVE RECEIVERS
 5 Valve Superhet, A.C./D.C. Mains, 90/250 volts. Tuning from 18-52, 200-550, 1,000-2,000 metres. Guaranteed to receive America at full Loudspeaker strength. Fitted with R.C.A. valves and fully guaranteed. Money returned if not satisfied. Wholesalers' stock to clear at £6/10/0. Cash with order or C.O.D.
MARKS (Dept. A), 31, Golders Gardens, London, N.W.11

ELECTRADIX SALE Our Season Sale is always open every week-day.

WE HAVE THE BIGGEST AND BEST STOCK OF GOVERNMENT SURPLUS RADIO AND ELECTRICAL GOODS.

Each article is genuine and no guess work. Those who have had our large Illustrated Sale List know the wide range of quality goods offered. Callers who have inspected our stock know that we have four large floors and a shop full of gear at sacrifice prices. As even our **BIG LIST** cannot keep up to date with our stock do please send us your enquiries as we probably have just what you want in our Store.
YOU CANNOT BEAT OUR PRICES FOR VALUE.

HEADPHONES, double Sullivan, All. headband, 2/9 per pair
PEDESTAL G.P.O. MICROPHONE with TELE PHONES, 6/6
GENUINE G.P.O. MIKE 3/6. **TRANSFORMER** 2/6.
BELL INDICATOR MOVEMENTS; 1/6 ea. G.P. Bells, 2/6.
CHECK METERS for slide phase mairs, 5/- ea.
SPARK COILS. 1cin. BUTT for X-Ray, 60/-, small ones per vertical.
X-RAY TUBES AND VALVES, new 6in. Bulb, 13/-.
BELL TRANSFORMERS, for A.C. Mains, 2/6. G.P.O. Vertical Galva, Mahogany Case, 4/6. **HORIZONTAL BRIDGE,** 7/6.
MARCONI, R.A.F. 7-valve AMPLIFIERS, teak and mahogany case, complete, 10/- to clear. **MARCONI, No. 55, 6-valve H.F., 1 L.F. AMPLIFIER, 15/-.** **OLD TYPE RECEIVERS, 5/-.** **LOOSE COUPLED ADJUSTABLE TUNERS,** broadcast to 5,400 m., brass fittings, 5/-. **Variometers,** lit wood, slotted panel, clean, 3/6.
10 KW. SILICA TRANSMITTING VALVE, 25/-. 500 watt, 100 watt, 40 watt and other sizes for Amateur transmitting in stock.
MICROPHONES. Complete unit, 1/-.
DYNAMOS for charging, 16 volts 15 amps., 25/-; hundreds of others, all sizes.
METERS. Special bargain line M.C. Hot C.Z., 25-0-25 m.a., flush, 12/6. M.I. Panel 0-4, 10, 20, 50 volts, 5/-, 100 volts, 5/6, 200 volts, 6/-. Special C.Z. Ammeters, 3-0-3, 5/-, Poie Testers.

2/6. Meter Movements, first grade Mav. Coil, 5/-. **Visual Tuning Meters** M.I. Edgewise, 6/-. **Flash Panel Illuminated dial,** 10 m.a., 25/-, Wattmeters, 200 watts, 250 volts, 30 cycles, 15/-. **MEGGERs** and **BRIDGES** cheap.
MAINS A.C. AMPLIFIERS, 24.
A.C. MOTORS. Induction 1 1/2 H.P., 12/-, upto 1 1/20th H.P., 35/-. Small double grinders, 21/6. Electric Drills, 30/6. **FANS,** 8in., 15/6, 10in., 35/-. Double shaft universal **MOTORS,** 35/- **ENGINE H.P. INDICATORS** in wood case, 30/-.

1,001 other Bargains for Laboratory Amateur and Pro. BIG ILLUSTRATED SALE LIST "N." FOR 11d. POST FREE.

ELECTRADIX RADIOS
 218, UPPER THAMES STREET, E.C.4.
 Phone: Central 4611. Grams: Electradix, Cent. London.

Short Ultra-Short UNIT RADIO CONVERTERS

5 to 100 METRES
 This S.U.S. Converter is the latest addition to our range of Short-Wave Converters. It is an entirely new model original in design and covering both Short and Ultra-Short wavebands. Special circuit employed gives maximum results on all wavebands. Enjoy all the advantages of an expensive all-wave set by just attaching the S.U.S. to your present receiver. There's a model for Battery or Mains users.

UNIT SHORT AND ULTRA-SHORT CONVERTER

Covers 5 to 100 metres. Aeroplane dial. Ratio 100-1. New Type with special scale. Two controls only. Two connections only to set. Also receives 240-line Television sound, in addition to world-wide short-wave broadcasts. All metal non-hand-capacity cabinet. Complete with valve ready for use.

PRICES
 Battery Model 506. £3 5 0.
 A.C. Mains Model 509. £3 12 6.

Cash or C.O.D. Carriage Paid. **Phone: CLE 5340.**
UNIT RADIO 347, CITY ROAD, LONDON, E.C.1.

FREE SERVICE

All Kits supplied by us are covered by our free service guarantee. Buy your Practical Wireless kits from us with full confidence of obtaining satisfactory results. **CURRENT RETAIL PRICES.** Orders over 5/- post free. Send stamp for details of our complete home-constructors' service. Receivers constructed, repaired, modernised. Diagrams supplied.

RADIO SERVICE BUREAU, 9A, SHEPHERD'S BUSH ROAD, LONDON, W.6.

NEW RECEIVERS, COMPONENTS AND ACCESSORIES

"NORTHUMBRIA" 1936 A.C. Five. Sales necessitate increased production, £8 8s. or terms. Catalogue from Novo Radio (2), Union Works, St. John Street, Newcastle-on-Tyne 1.

EASY PAYMENTS "THERES NO PLACE LIKE HOLMES" **SPEAKERS**

	Deposit	Monthly Payments
W.B. DUPLEX	84/-	7/8 11 of 7/8
W.B. SENIOR	42/-	4/7 9 of 4/7
W.B. JUNIOR	32/6	4/5 7 of 4/5
BLUE SPOT SENIOR	29/6	4/- 7 of 4/1
ROLA F720	35/-	3/10 9 of 3/10

Any make of speaker supplied.
KIT SETS
 LISSEN Skyserapet 3, with valves .. 60/- 5/6 11 of 5/6
 GRAHAM FARISH Jubilee 3 .. 36/6 4/7 9 of 4/-
 GRAHAM FARISH Sensity Snpr .. 50/- 4/7 11 of 4/7

COMPLETE SETS
 COSSOR No. 363 .. 125- 12/4 11 of 12/4
 COSSOR No. 369A. AC/DC .. 168- 15/- 11 of 15/8
 G.E.O. Battery S.G.3 .. 159/6 18/6 12 of 13/6
 FERRANTI UNA, AC/DC .. 178/6 16/- 12 of 15/-
 Any make of set supplied. Purchase your set on H.P. from us and avoid local knowledge.

ACCESSORIES of merit and fine value.
 EXIDE H.T. ACC. 120v. .. 80/- 6/- 9 of 6/8
 ATLAS ELIMINATOR T.10/30 .. 69/6 6/- 11 of 6/4
 AVONINOR METER .. 40/- 5/6 7 of 5/6
 B.T.H. LATEST PICK-UP .. 80/- 4/5 9 of 4/5
PARTS FOR ANY SET. ANY MAKE OF SPEAKER.
 New goods obtainable for every order.

Send us a list of parts or valves you require or any speaker or set you may select and we will forward you a definite quotation. Ten years' advertiser to the Wireless Press. Thousands of satisfied customers.

H. W. HOLMES,
NEW ADDRESS: 333, EUSTON ROAD, LONDON, N.W.1.
 Phone: Museum 1414.

JUDGMENT SUSTAINED

Thousands have already proved that their choice of **362 RADIO VALVES FOR ALL THEIR REPLACEMENT NEEDS** was the first real step towards **RADIO RELIABILITY.**
 Latest lists post free from
THE 362 RADIO VALVE CO., LTD.,
 Stoneham Works, Stoneham Road, London, E.5.
 (Tel. Chisold 6607).

MISCELLANEOUS

YOU CAN USE YOUR SPARE TIME to Start a Mail Order Business that quickly brings you a full-time income. Follow the lead of others who are averaging £12 per week net profits. Get away from a drudging routine job—join the big-money class. No previous experience necessary. Few pounds capital only needed. No samples or outfits to buy; no rent, rates or canvassing. New method makes success certain. Write to-day for **FREE BOOKLET** to Business Service Institute, Dept. (213c) 0, Carmelite Street, London, E.C.4.

REPAIRS, all makes moving-coil speakers. New Cones, etc., fitted and modernised with "High Tone Diaphragm Accentuator." Complete **REWINDING** service. Discount Trade.

WEEDON'S Repair Services, 262, Romford Road, Forest Gate, London, E.7. Maryland 1782.

REPAIRS to Moving Coil Speakers, Cones and Coils fitted, or rewound. Fields altered. Prices Quoted Including Eliminators. Loud-speakers Re-paired, 4/-. L.F. and Speech Transformers, 4/- Post Free. Trade Invited. Guaranteed Satisfaction. Prompt Service, Estimates Free. L.S. Repair Service, —5, Balham Grove, London, S.W.12. Battersea 1321.

AN extra good allowance made on your old set or parts in part exchange for any new receiver for cash or easy terms. We take your goods as deposit. Peto-Scott kits and components supplied for cash only, or part exchange. Highest allowances; prompt attention.—R. Wigfield, Wireless Agent, Furlong Road, Goldthorpe, Yorks.

Piano Tone CABINETS
65/- RADIO-GRAM 35/-
 NO MIDDLE PROFITS.
 Finest Radio Furniture as supplied to B.B.C.
LIST FREE. PICKETT'S
 CABINET (P.R.) WORKS, Boxleybeath, nr. London.

FREE ADVICE BUREAU COUPON
 This coupon is available until October 19, 1935, and must be attached to all letters containing queries.
PRACTICAL AND AMATEUR WIRELESS, 12/10/35.

OF TECHNICAL IMPORTANCE

FOR GREATER UNDISTORTED POWER OUTPUT AT MODERATE VOLTAGES

Osram Valves

MADE IN ENGLAND
Sold by All Radio Dealers

NEW

POWER TRIODES

TYPE **PX25A** TYPE **DA30**

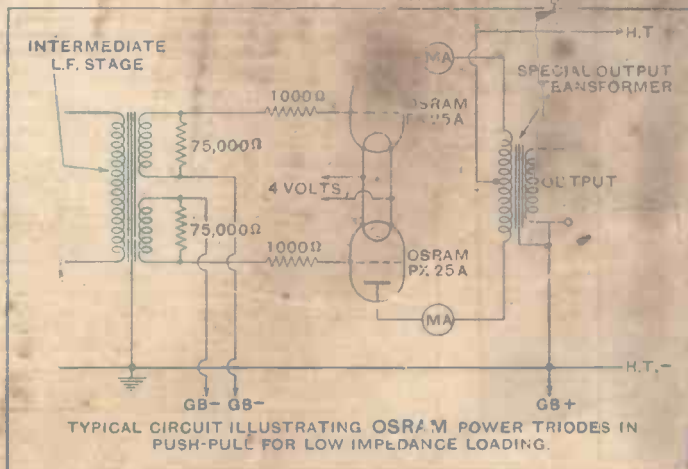

"Low Impedance Loading" is a method of using a pair of Output Valves in a push-pull circuit to obtain a considerable increase in undistorted power, without resort to high H.T. voltage or the necessity for positive grid drive.

The success of the system depends on the characteristics of the valves and on the design of transformers employed. Full particulars are available on application.

CHARACTERISTICS	TYPE PX25A	TYPE DA30
Filament Volts	4.0	4.0
Filament Current	2.0 amp	2.0 amp
Anode Volts	400 max	500 max
Ampln. Factor	3.2	3.5
Impedance	865 ohms	910 ohms
Mutual Conductance (at working point)	3.7 ma/v	3.85 ma/v
Load Resistance (for "Low Loading" push-pull) (Anode to Anode)	2,800 ohms	3,400 ohms
Price each:	25/-	30/-

WRITE FOR NEW OSRAM VALVE GUIDE

OSRAM PX25A is a Power Triode designed for use in pairs where a maximum H.T. voltage of 400 is available. The rated dissipation of the PX25A type is 25 watts.

OSRAM DA30 is a Power Triode for use in amplifiers where a greater output is required and where a maximum H.T. voltage of 500 is obtainable. The rated dissipation of the DA30 type is 30 watts.

OSRAM VALVES — DESIGNED TO ASSIST THE DESIGNER

Advt. of The General Electric Co., Ltd., Magnet House, Kingsway, London, W.C.2.

65 *Practical and Amateur Wireless*™

Short-Wave Handbook

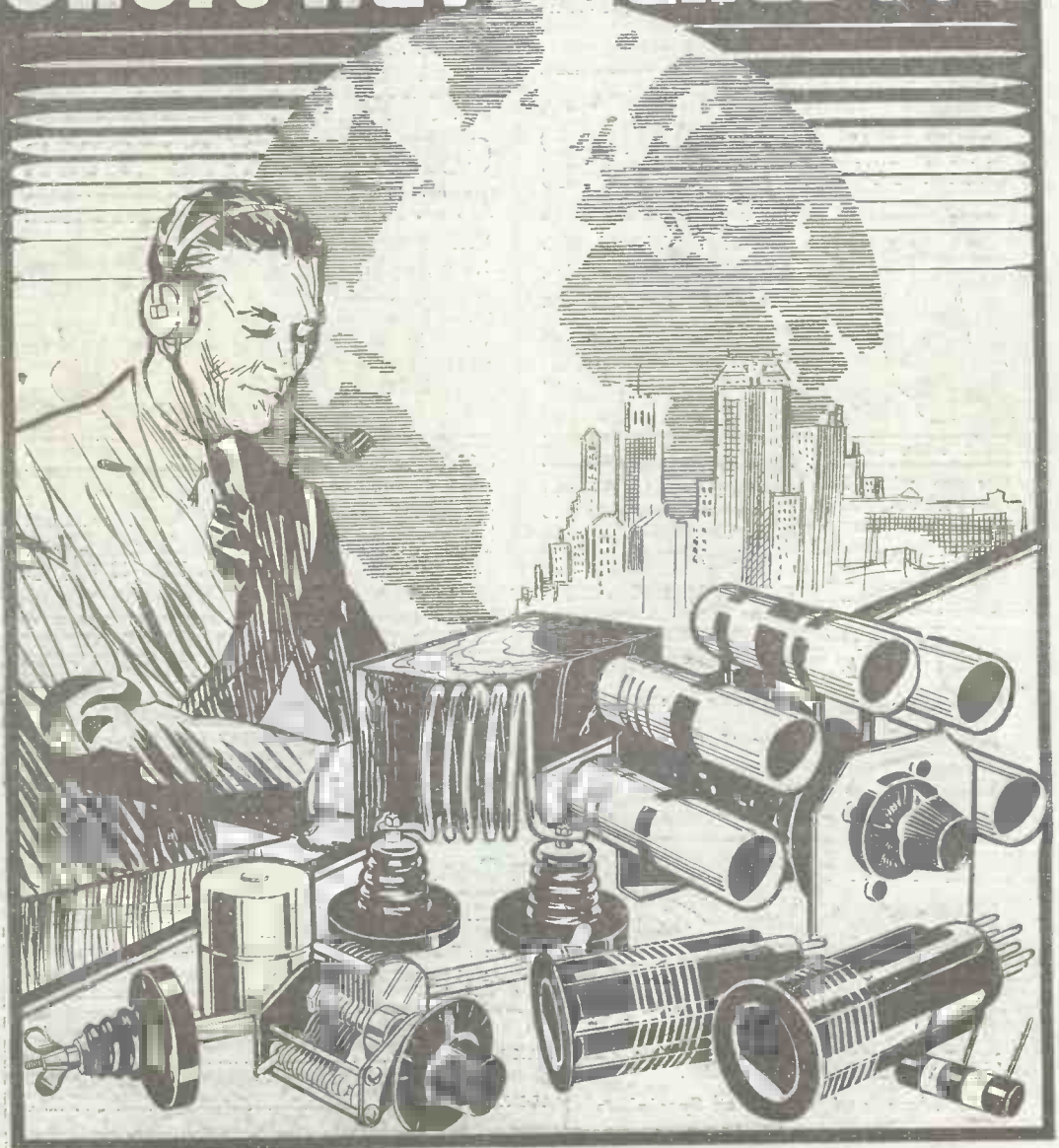

MR. F. J. CAMM USES and Exclusively SPECIFIES B.T.S. COMPONENTS

It is only natural that Mr. F. J. Camm, who has consistently used and specified B.T.S. Components for almost all of his famous sets in the past, should exclusively choose B.T.S. for the most vital parts of his two latest and greatest Short Wave circuits. What better example do you need? . . . YOU should insist upon B.T.S.

FOR THE

SHORTWAVE 3 B.T.S. 6-PIN Short Wave COILS



Formers mounted on Megacite. Wound with hard drawn copper wire. Set of 3, 13-26, 24-52, and 46-96 metres, Types SPA, SPC, SPD.

The set **13/6**

B.T.S. 6-PIN COIL BASE

For use with B.T.S. Short Wave Coils. Sub-chassis mounting.

Type SPB. **2/-**

B.T.S. H.F. CHOKE

(Unscreened.) Wound on hollow steatite former.

Type 103. **2/9**

OBTAINABLE FROM ALL RADIO DEALERS.

FOR THE

SHORT-WAVE CONVERTOR-ADAPTOR B.T.S. REACTION CONDENSER

Vernier motion of 10:1, giving extremely smooth action and minute accuracy. With knob and pointer. Type RC32 .0002 mfd.

5/6

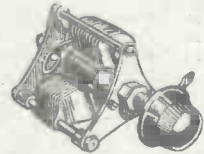

B.T.S. VOLUME CONTROL

Totally enclosed. Absolutely silent in operation.

Type VC100 (100,000 ohms). **3/6**

B.T.S. TUNING CONDENSER

Specially designed for short wave working.

.0002 mfd. Type TRC 32 **4/6**

HERE'S THE IDEAL RECEIVER FOR THE SHORT WAVE BEGINNER B.T.S. "OCEANIC" BANDSPREAD SHORT WAVE 3 KIT

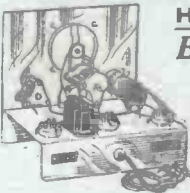

"Bandspread" for simplified short wave tuning! Designed by B.T.S. to enable the beginner, as well as the advanced enthusiast, easily, quickly, and inexpensively to build an efficient yet simply operated Bandspread short-wave receiver.

● BANDSPREAD CONDENSER, giving the minute tuning accuracy of a slow motion condenser, whilst eliminating tedious "knob-twirling" and backlash. ● Triode detector, amplifier and output valves. ● Aperiodic coupled aerial and grid circuit. ● B.T.S. Triple range Coil, Ranges 12-25, 19-40, and 30-80 metres. ● NO COIL CHANGING.

● Fully described in the First Issue of "The Short Wave Constructor," FREE to all who send coupon below.

Complete Kit of Parts for building, less Valves, £2:15:0

FREE! No. 1 of "The Short Wave Constructor"—POST COUPON

B.T.S.

Short Wave and Television Specialists

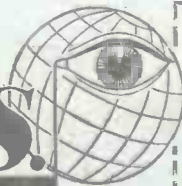

BRITISH TELEVISION SUPPLIES LTD., Bush House, London, W.C.2.

Telegrams: Television, Bush, London. Telephone: Temple Bar, 0134.

Please send me, entirely free, No. 1 of "The Short Wave Constructor," the new 3d. B.T.S. Magazine for Short Wave Fans, immediately on publication. I enclose 3d. in stamps for postage.

NAME

ADDRESS

Practical and Amateur Wireless Short-Wave Handbook

WHAT ARE SHORT WAVES ?

THE term "short waves" is often heard now in connection with broadcasting, but to many ordinary listeners it represents some unknown portion of the air upon which only enthusiastic experimenters and technicians can spend their leisure hours. In point of fact this is a completely erroneous idea, and has arisen from the mysterious way in which short-wave information is offered in the pages of various papers and periodicals and the high-sounding technical expressions which are used in connection with such information. As listeners are already aware, the wireless signals are broadcast on various wavelengths, and in our standard broadcast receivers we have two separate bands of waves upon which the standard broadcast stations may be heard. On the majority of receivers these are classified as "medium" and "long," although in some older receivers the former band is often referred to as "short." These two bands may be definitely stated as covering wavelengths from 200 to 1,000 on the medium range, and from 1,000 upwards on the long range.

It is, however, quite possible to radiate a signal on a wavelength below 200, and the shortest wavelength to be used has not yet been located, although transmissions have been successfully carried out on such minute wavelengths as .5 centimetres. It has, owing to the difference in technique which is required on various ranges, been found convenient in the past year or so to subdivide the lower wavelengths into two ranges, and to refer to those wavelengths from 10 to 100 metres as "short waves," and all wavelengths below 10 metres as "ultra-short" waves. The band from 100 to 200 metres is not employed for entertainment broadcasts, but is reserved for certain Government and commercial transmissions.

Wavelengths and Frequencies

One reason for the lack of general interest in short-wave reception is to be found in the fact that there is a certain amount of skill required in the construction of the apparatus and in its operation. This skill, however, has arisen owing to the wrong design of the apparatus originally offered to the public, and it has, unfortunately, led to the present-day impression mentioned in the opening paragraph. We have adopted in this country a standard of wavelengths when referring to any given station. Thus, we know the London National transmitter uses a wavelength of 261.1 metres, and the Droitwich transmitter radiates on a

wavelength of 1,500 metres. How many listeners know, however, that the frequency of the Droitwich transmitter is 200 kc/s? Yet this is really the most valuable information, and is far more informative than the wavelength measurement, as well as being more simple to remember owing to the lack of the decimal fraction. It may be assumed now that every listener knows that the signals from a broadcasting station are sent out by means of electrical impulses, and that these are carried on a constant electrical oscillation known as the "carrier wave." This latter is controlled by very elaborate apparatus at the transmitting station and is very constant in its form. As has so repeatedly been stated, it may be likened to the wave-form on the sea, and the wavelength is the distance from the top of one wave to the top of the next.

Now the most important factor in dealing with these signals is the rate at which they travel, and it is obvious, if one considers the analogy of the sea waves, that the distance from one wave to another is very closely allied to the time taken for a wave to pass a given point. In other words, if we take, instead of a measurement of distance, a measure of time, say one second, we shall find that in that time there would only be a few waves (or oscillations) for a long-wave signal, whereas for a short-wave signal there would be very many more. The kilocycle is the standard by which these signals are measured, and, as the name indicates, it means 1,000 cycles per second. A cycle is the same as a "wavelength"—it is the distance or time from the top of one wave to the top of the next, and thus 200 cycles would mean 200 waves, whilst 200 kilocycles (which is abbreviated to 200 kc/s) means 200-thousand cycles.

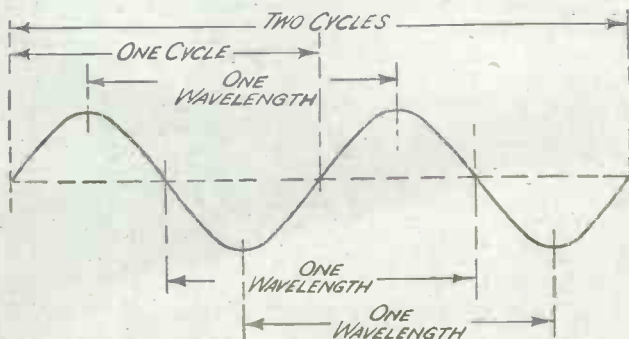

This diagram explains the relation between wavelength and frequency, and shows how these terms are measured.

The Speed of Wireless Waves

It has been stated that wireless waves travel at the speed of light, and this latter figure has been stated by scientists to be 300,000,000 metres per second. If, therefore, a station sends out a signal in which the wave or oscillation occurs only once per second, the wavelength would be 300,000,000 metres. In other words, a frequency of one cycle equals 300,000,000 metres. As the wavelength shortens the frequency rises, and it is in this respect that the short waves present a slight difficulty. From the figures given above it is obvious that the wavelengths may be converted into frequencies by dividing 300,000 by the number of metres, and the answer will then be in kilocycles (or thousands of cycles). A wavelength of 200 metres thus equals a frequency of 1,500 kilocycles, and a wavelength of 10 metres equals a frequency of 30,000 kilocycles. To avoid the large number of figures in these very short wavelengths it is now becoming customary to use the term "megacycles," which means millions of cycles, and thus, instead of referring

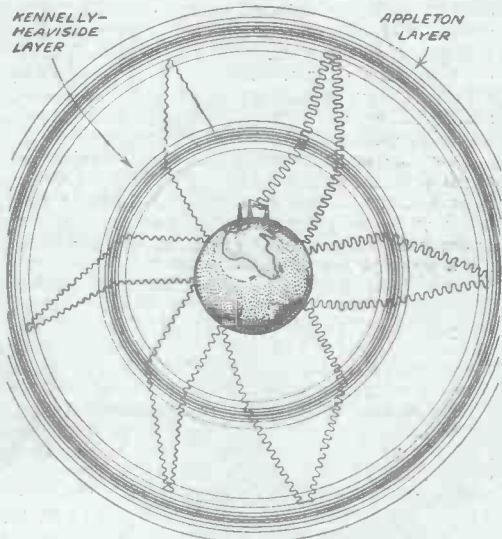

Diagram explaining the action of the ionised layers in reflecting and deflecting wireless signals.

to 30,000 kilocycles, we would refer to 30 megacycles or 30 mc/s. This, then, disposes of one of the main difficulties of short-wave information, the reference to frequencies, and should also clear up a lot of misconception relating to the terms kilocycles and megacycles.

The Advantages of Short Waves

Owing to the previously-mentioned facts, a short-wave radiation may be employed in vastly different schemes than ordinary medium or long waves. It is, in fact, possible to use a very short aerial for the transmission, and to place this in front of a reflector (in the same manner as an ordinary light) and to direct the signal in a more or less straight line or beam. When this is done, the signal

may be sent for a tremendous distance, with the employment of only a very small power, as there is no loss of energy due to the usual radiation of the signal in all directions equally. On the ordinary broadcast wavelengths the signal leaves the aerial in the form of an ever-widening circle and on these wavelengths it is usually the wave-form which is following the outline of the surface of the earth which is picked up, and which naturally gives a constant strength of signal. If, however, the receiver is situated at some point beyond the range of this direct wave, then it is still possible to hear the signal by receiving a wave which is reflected from a layer of what is known as "ionised atmosphere" situated some distance above the surface of the earth. It is now generally accepted that there are two such layers, the nearer known as the Kennelly-Heaviside Layer, and a further band beyond this known as the Appleton Layer. The former band lies at a distance of about 60 miles above the earth, and the latter at about 130 miles above the earth's surface. Now waves of fairly low frequency are reflected by the first layer, but as the frequency increases (or the wavelengths become shorter) they penetrate the first layer and are then reflected by the outer or Appleton Layer. At present, there is no known reason to account for the peculiarities of behaviour of these two layers. A station may send out a signal, for instance, in England, and this may be absolutely inaudible in every part of the country, and yet may be received with great power in, say, Spain. It is believed that the signal strikes the first layer and becomes slightly deflected, passes on to the second layer and is directed back towards the earth, and is further deflected on passing through the first layer. It is not possible, however, to plot any definite course for the wave, and that is why it is becoming so useful to employ the directed or beam signal.

On the short and ultra-short waves, the direct radiation is very short indeed, as the signal naturally weakens as it gets farther from the station, and the higher the frequency, the quicker becomes this weakening or dying out. Below 10 metres the actual direct range of a station is practically the same as that of a powerful light, and this has given rise to the term "optical range." It means, in effect, that if the station can be seen under normal conditions, the signal could be picked up. But if out of sight the signal could not be picked up—no matter how powerful the apparatus. At the moment, some doubt still exists regarding this point, as a recent transmission was carried out for test purposes and the signal was picked up over 200 miles away—but whether or not this was a freak reception due to some peculiar local condition has not yet been discovered. The proposed television transmissions on a wavelength of 6 or 7 metres will, however, only be considered effective over a range of about 25 miles, and it is upon this basis that the Post Office and the B.B.C. are working.

Very small powers may be employed on the short waves, and many more stations may be included in a narrow band, thus providing better quality of signals and a greater selection of programmes, with a practically complete freedom from atmospheric disturbances. These latter are

far more noticeable on the long waves than on the short waves, although such items as motor-car ignition noises may be heard on certain short wavelengths.

Why More Stations can be Used

It would perhaps be as well to point out here that for normal good musical reproduction, a band of frequencies of 10,000 cycles is considered ample on the ordinary broadcast wavelengths. Thus, it has been laid down that on the medium-wave band stations shall be separated from each other by 10 kc/s. For really high-definition television pictures, a frequency band much greater than this is required, and it is even possible that a band of 1,000 or 2,000 kc/s will be used. On the medium waves, of course, this would mean that a station transmitting on a wavelength of 300 metres, and using a total frequency band of 1,000 kc/s would be heard over a band from 200 metres to 600 metres! It will be seen, therefore, why the special short waves have got to be used for high-definition television transmissions.

Short-wave Reception

All the ordinary broadcast features are employed on the short waves, and it is only necessary to bear in mind that, owing to the high frequencies which are used, every precaution must be taken to avoid the loss of the signal. At these high frequencies the small amount of energy which is picked up will pass via the smallest capacity to earth, and, therefore, the question of insulation is of vital importance. In the past it was necessary to use

all kinds of artifices to reduce the risk of these losses, but to-day various special materials are being manufactured and components are easily obtainable from all wireless stores which may be wired into a receiver for use on the short waves in exactly the same manner as in ordinary broadcast receivers. Such items as coils, for instance, may be obtained on special formers with the wire rigidly fixed in position so that no variation in tuning settings can arise. Tuning condensers also, may now be obtained at quite reasonable prices, which will enable the maximum results to be obtained without recourse to any special mechanical modifications. Special slow-motion gearing is incorporated in some models, whilst with others ordinary slow-motion dials may be used, and these components are to-day of such a high degree of accuracy, that the construction of the receiver is not one iota more difficult than that of a broadcast receiver.

Choosing a Circuit

Ordinary high-frequency amplification is ineffective on the very short waves, and thus the simplest of circuits may be adopted, or, if a greater certainty of long-range results is required, a superhet circuit may be employed. The ordinary broadcast receiver

may be adapted for use on the short waves, and in this book there are two different types of adapter which may be employed with a standard receiver for the purpose. There is also a reliable three-valve circuit which may be built by those who wish to construct a complete short-wave set. In view of the remarks which have been made concerning the necessity for preventing losses, it is obviously necessary to pay some care and attention to the type of aerial which is used, and although a standard broadcast aerial will be found quite satisfactory in many cases, it will often prove worth while to erect a separate aerial for short-wave work, making this in the form of a vertical wire. Details are given elsewhere concerning this part of the equipment.

The Earth Connection

The earth must be reliable, and provided that good results are obtained on the broadcast band

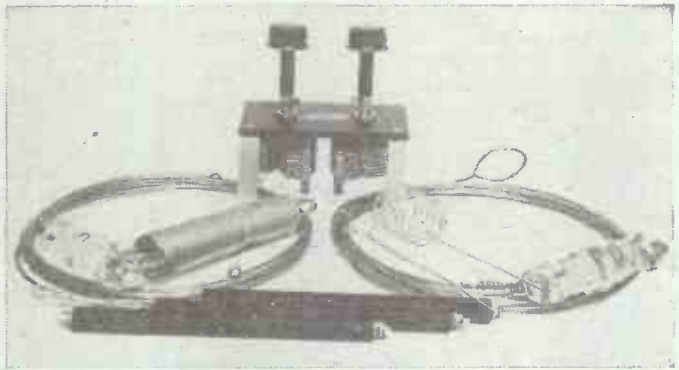

A typical special short-wave aerial lead-in system, showing the special coupling unit and the glass insulators which are employed.

with the earth, it may be taken for granted that it will prove satisfactory on short waves.

What You Will Hear

With regard to the material which may be heard on the short waves, it may be mentioned that practically every country now transmits its broadcast programmes on the short waves as well as on the ordinary bands, and in addition there are many interesting experimental transmissions carried out by amateurs and technicians in all parts of the world, and these, with the forthcoming television transmissions, lend added interest to the subject of short-wave signals. Each week in the special PRACTICAL AND AMATEUR WIRELESS Short-wave Section, we deal with improvements in short-wave apparatus and technique, and also give complete up-to-the-minute details of the new transmissions, alterations in times and wavelengths, and all other details which are necessary for those who are interested in the subject, and by adding the short-waves to the existing broadcast signals, it is possible to increase the material which is available for your entertainment one hundredfold, and to be able to hear signals at any time of the day or night.

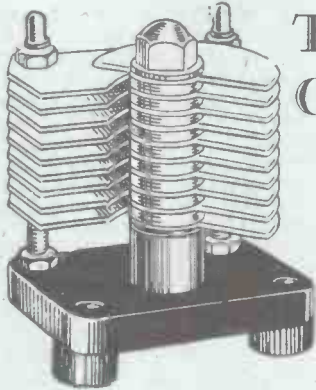

A J.B. air-dielectric pre-set condenser, which is useful as a trimming or matching control. It is made in three capacities—50, 75 and 100 mmfd.

Typical 1936 Short-Wave Components which Simplify Home Construction

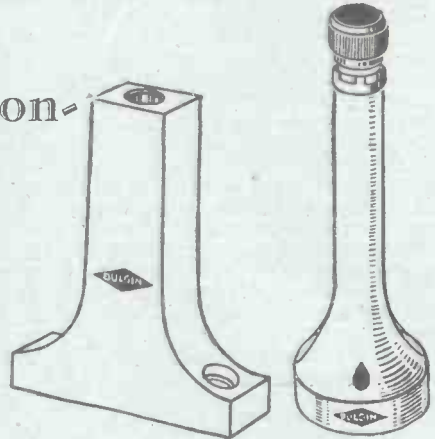

A pair of Bulgin pillar insulators. There are many uses for these in the modern S.W. receiver, for they can be employed as component supports, or for receiving wire connections.

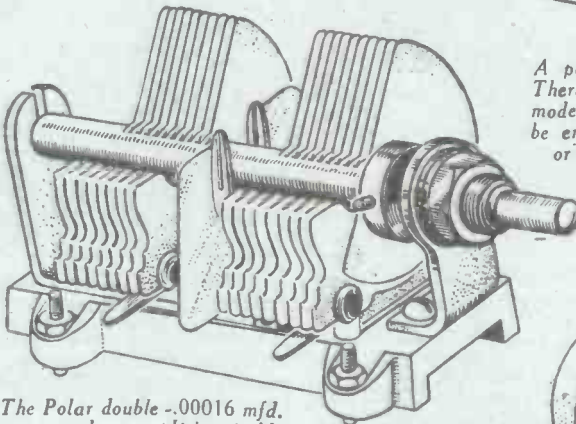

The Polar double .00016 mfd. gang condenser. It is suitable for use in a modern ultra-short-wave superhet. The condenser is also available as a "single" model.

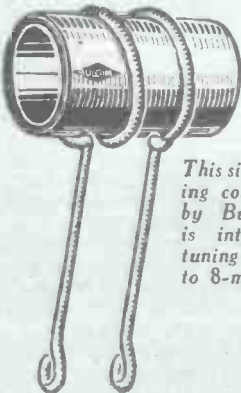

This simple-looking coil is made by Bulgin, and is intended for tuning on the 5 to 8-metre band.

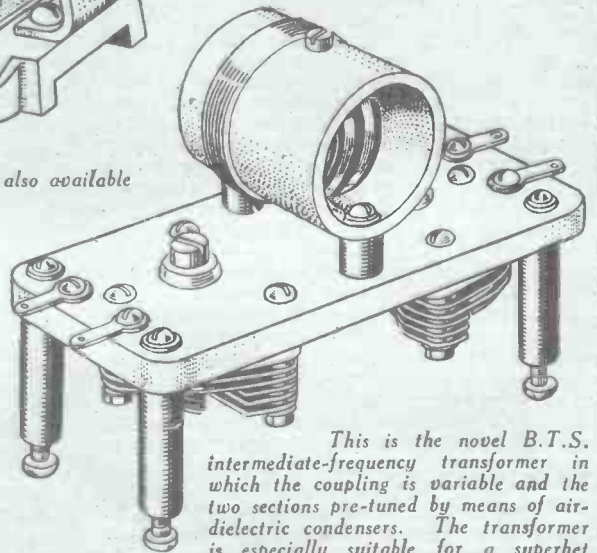

This is the novel B.T.S. intermediate-frequency transformer in which the coupling is variable and the two sections pre-tuned by means of air-dielectric condensers. The transformer is especially suitable for a superhet designed for the reception of high-definition television.

SPECIAL SHORT-WAVE AERIALS

MANY items of domestic utility, as well as certain types of ordinary electrical mechanism, produce and radiate a form of electrical disturbance which becomes very troublesome on the short waves, unless special precautions are adopted for its exclusion. It is obvious, of course, that such precautionary measures must also be used to avoid the combination of a signal and interference, and thus any form of disturbance eliminator must be carefully designed in order that

device at the receiver, the aerial may be tuned and thus maximum signals obtained at any definite frequency, to the exclusion of all other signals.

There is, of course, the well-known screened down-lead for use with an ordinary aerial, but in many cases it will be found that these are not ideal when reception is desired on wavelengths of the order of 5 metres and thereabouts, and thus the transposed aerial systems should be adopted by those who are anxious to obtain maximum results on the short and ultra-short waves, and where interference is experienced.

The System Explained

The illustrations accompanying this section show four different types of aerial, but they all employ a transposed lead-in system, and it will be seen that there are a number of small units arranged at intervals throughout the length of the lead-in wire, as shown in the accompanying illustration. The wires are simply passed round the ends of the small transposition block as it is called, and are held in position by the wires themselves. In the simplest scheme, a short length of aerial wire is cut at the centre, and insulated not only at both ends, but at the centre point where it is joined. As with all other short-wave apparatus, a high degree of insulation is required, and therefore high-class insulators should be employed. Special types of glass insulator are obtainable, and these are also provided with a corrugated surface so as to increase the actual leakage surface. One of these is shown on page 5. From the centre of the two wires ordinary lead-in wires are run, and these should be crossed through the transposition blocks as shown. In order to couple the two ends of the lead-in cable to the receiver it is obviously necessary to join the ends together, and this is generally accomplished through a very small coil employing either one or two turns. Alternatively, two coils may be used and joined in series with a small tuning condenser

only the disturbance is removed. The majority of ordinary electrical mechanisms may be fitted with special suppressors, which have the effect of reducing the trouble, at the source, and in the majority of cases there is no difficulty about such remedies. On the other hand, motor-cars and similar moving bodies also radiate this form of interference and, except in those rare cases where the car is fitted with car radio and thus has had to be doctored to remove the interference, it is possible to pick up the radiated energy over quite a large distance. In the ordinary home receiver this noise will not be heard, but when a short-wave adaptor is employed, or a special short-wave receiver, the interference will be heard as a gradually increasing "clicking" noise, rising to a maximum in volume as the car passes the house, and then dying away as the vehicle proceeds on its way.

A Simple Remedy

It is obviously essential that any form of interference eliminator in this case must rest with the user of the receiving apparatus, and it has been found as a result of experiment, that a special form of aerial will enable the majority of ordinary forms of electrical interference to be removed, whilst still permitting of the reception at good signal strength of various radio transmissions. In general, these forms of aerial are referred to as "transposed aerial systems," and explained briefly it may be said that they consist of a short aerial wire, divided into two portions, and with the leading-in wires from each section crossed at intervals on the way to the receiver. By using special forms of coupling

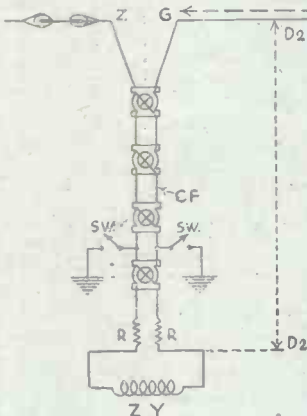

Fig. 1.—A single wire, or inverted 'L' type aerial, with a transposed leading-in system. The use of the coil ZY is explained in the text.

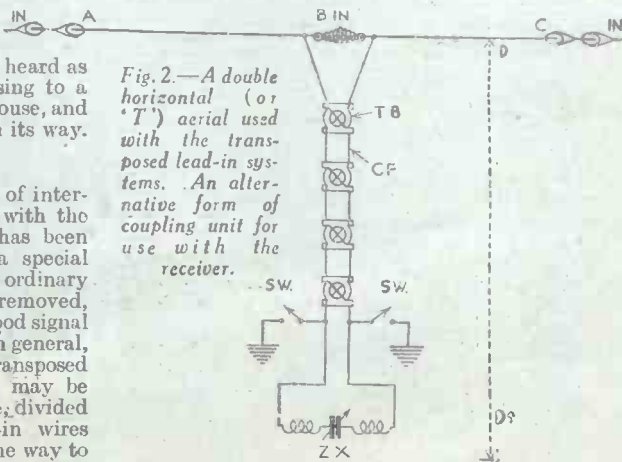

Fig. 2.—A double horizontal (or 'T') aerial used with the transposed lead-in systems. An alternative form of coupling unit for use with the receiver.

as shown in Fig. 2. In Fig. 1, an inverted "L"-type of aerial is employed, this following more or less the arrangement adopted by the majority of listeners for broadcast reception, with the addition of the extra lead-in wire from the point "Z." In Fig. 4 the aerial is also in two sections, but each section is made up of a number of wires arranged at regular intervals round the periphery of a small wooden hoop or similar article, and thus forms a "cage" or "Zeppelin" aerial. A similar method is adopted in the aerial system shown in Fig. 3, where only a single cage is employed, and this is a modification of Fig. 1.

Coupling to the Receiver

In the simplest case, the two wires from the lead-in system may be joined to aerial and earth terminals, but better results are obtained if the coupling devices previously mentioned are adopted. A special scheme which is valuable on the ultra-short waves is to wrap the grid coil with a small strip of metal foil (preserving the insulation between the turns of the coil), and so designing the size of the metal strip that a very small space is left between the two ends. A single turn of wire is then placed round this, and the lead-in wires are joined to the ends of this single turn, and thus coupling between the two coils is rendered entirely inductive.

The Size of the Aerial

The aerial proper should be of medium length, say 40 feet, but the lead-in wires may be of any length, and this gives to the system one of its advantages. It is obvious, for instance, that where any form of interference arises from apparatus situated near to the receiving apparatus, the aerial may be erected at some distance, well clear of the interference, and the transmission line (or leading-in system) may be carried to the receiver, and thus the interference may be removed. On the other hand, with certain types of receiver it may be found desirable to so select the size of the aerial that the two halves are equal to one half of the

wavelength of the station being received, whilst in other cases the total length of the aerial system, including the transmission line, may equal the wavelength of the received station. These latter schemes only apply, of course, where it is desired to obtain maximum results from one station, and thus the scheme lends itself to the

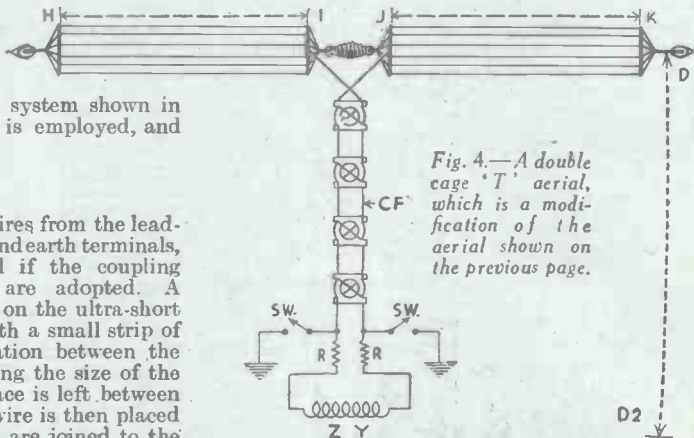

Fig. 4.—A double cage "T" aerial, which is a modification of the aerial shown on the previous page.

reception of the television transmissions emanating from a local station, where maximum response is required free from interference.

A vertical aerial is generally to be preferred for S.W. and U.S.W. reception when interference is not normally experienced, and the arrangement shown on the right is useful in that it is perfectly rigid. Good contact between the different lengths of pipe must be ensured.

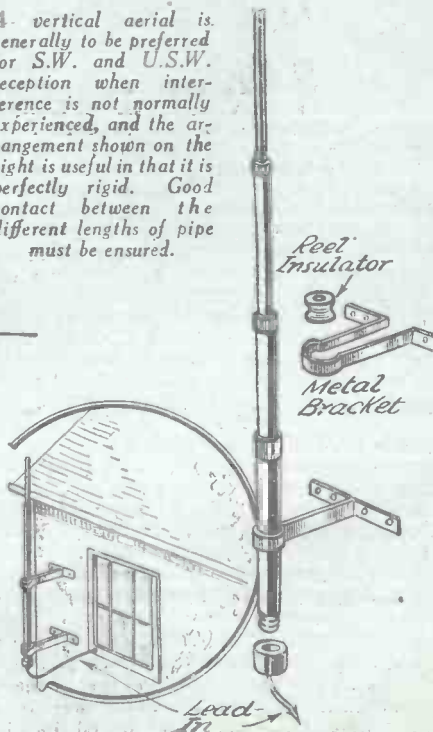
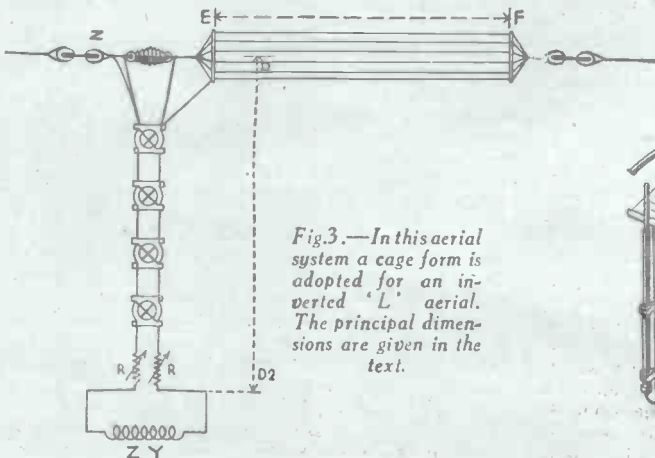

Fig. 3.—In this aerial system a cage form is adopted for an inverted "L" aerial. The principal dimensions are given in the text.



OBTAINING QSL CARDS—OR REPORTING ON TRANSMISSIONS

MUCH interest may be added to short-wave listening if a knowledge of the Morse code is obtained and amateur transmissions are picked up and reported upon. In the majority of cases such reports will be replied to by means of what is known as a QSL card, or a verification of reception. These cards take many novel forms, and in different parts of the world different schemes are adopted to make these cards pictorial as well as decorative. The result is that the "den" of an enthusiastic short-wave fan is generally provided with walls which are "papered" with such cards,

5-metre bands. In terms of frequency, these are generally referred to as the 1.7, 3.5, 7, 14, 28, and 56-megacycle bands.

Daylight and Darkness

The 160-metre (1.7 mc.) band is generally used for local working only, and provides a daylight range of some thirty to forty miles. After dark much greater distances are possible, and during the last three years the Atlantic has been crossed several times by 10-watt stations on both C.W. and telephony.



A group of QSL cards received by an amateur. These indicate the varied forms which are adopted, but the colouring adds to the attractiveness of these cards.

and it gives a good indication of the patience of the operator, and the efficiency of the apparatus.

Obviously, these cards cost money to produce, and, therefore, the recipient of a report of reception desires to have some information which will warrant the expense of sending a QSL card, and on this account the following notes should be borne in mind by those who are desirous of obtaining a collection of these cards.

The various wavelengths function in different manners according to atmospheric conditions, and, therefore, before it can be explained which transmissions should be dealt with at a given time it is necessary to know the function of the different wavelengths. The short waves may be divided into bands, comprising the 160, 80, 40, 20, 10, and

Therefore, whilst a transmitter in Scotland would be very glad to have an after-dark 'phone report from the south of England, there would be no point in a listener sending confirmation of reception, unless he had something very unusual to report, to a transmitter in the same town who is in regular contact with stations in his own neighbourhood. On this particular band under good conditions, real distance working can be obtained and many east-coast American and Canadian C.W. and 'phone stations can be heard after midnight and in the early hours of the morning. Generally speaking, reports are welcome on this band.

On the 80-metre (3.5 mc.) band, which provides good contact over the United Kingdom in daylight, and distance working even to the

Antipodes at certain times when conditions are good, usually the early mornings, American and Continental 'phone stations are interested in reports from this country, but you should leave alone the G stations who work all over England and every Sunday morning. They know they can be heard! Again, however, some discrimination is needed, as a new station, or one formerly working on C.W. only, may come on the air with an initial telephony attempt and thus your report may be valuable.

On the 40-metre (7 mc.) band, which is known as the "international night" band, the whole of Europe can be covered in daylight under normal conditions, and at the right time DX such as the Antipodes and more distant Americans early in the morning and long-distance eastern stations in the late evening, is usually expected. Listen for new call-signs and stations which do not seem to be getting contacts, and send them detailed reports. Continental telephony stations are glad of reports from English listeners, but, remember, that the powerful stations who are working regularly get thousands of reports.

The next band is the 20-metre (14 mc.) band, and this is generally referred to as the "international day" band. American amateurs may be

heard on 'phones in the middle of the afternoon on this particular band of frequencies, so you must search for the transmitter who puts out calls without reply and seems to be in touch with nobody. He will value your report. In general, any telephony transmission on 20 metres is DX, and is of interest accordingly.

The ten and five-metre bands may be taken together, since at present they are purely experimental channels, not used for regular communication outside ground-wave range. They are, therefore, of particular interest to the experimenter, and listeners can be most helpful. Any transmission is worth reporting, as not only amateurs, but research laboratories are still groping in the dark as regards the uses of these bands for contact outside the ground-wave range. On 5 metres particularly, any reception outside the "optical" range should be reported, and may be of the greatest interest and importance.

The report should give the time (G.M.T.); the strength of the signal in the R code; the readability or freedom from interference; the quality; whether fading is experienced and any other atmospheric conditions which may be of interest in analysing the conditions of the transmission and reception. Details of your receiver should, be included.

A SHORT-WAVE CONVERTER/ADAPTER

TO use a standard broadcast receiver on the short waves a special piece of apparatus may be added in front of the receiver to convert it for the new conditions. This additional apparatus may take one of two forms—it may adapt the receiver for short-wave tuning, or it may convert the broadcast receiver into a superhet. Thus, the apparatus is referred to as a "short-wave converter" or a "short-wave adapter." The differences in these two pieces of apparatus lie more with the type of receiver, as the adapter may be used with any receiver, whereas the converter can only be used with a broadcast set in which H.F. amplification is employed. Explained briefly, it may be stated that the adapter takes the place of the detector stage in a broadcast receiver, and is thus equipped with short-wave tuning circuits, whereas the converter is a combined frequency-changer and first detector and must thus be followed by H.F. stages tuned to a high wavelength. In the apparatus here described, both types of apparatus are combined in one unit, and it is thus possible to use the unit with any type of receiver.

The circuit is shown on page 11, and it will be seen that a special short-wave tuning unit is employed, and this is provided with separate coils which may be plugged in in order to cover any desired range. An S.G. valve is employed, and a potentiometer device enables the critical setting to be obtained which provides smooth reaction at any setting. Included in the anode circuit of the valve are two chokes—one of the ordinary broadcast type and one special short-wave choke, across which is connected a small pre-set condenser. This

combination may be regarded as an intermediate-frequency transformer, and the connection to the existing broadcast receiver is taken from the junction of these two chokes.

When the unit is to be used as an adapter the detector valve in the broadcast receiver is removed from its socket, and the lead marked "Adapter" is plugged into the anode socket of the valveholder in the broadcast receiver. Thus, the unit becomes a simple short-wave detector stage, and the anode circuit is joined to the L.F. coupling component in the broadcast receiver, the tuning arrangements in this becoming inoperative as the detector valve is removed.

Construction

When using the unit as a converter, the lead marked "Converter" is joined to the aerial terminal of the broadcast receiver and the tuned circuits in this are set to about 1,500 to 2,000 metres. Tuning is then carried out entirely on the unit, and subsequently the small pre-set condenser may be adjusted in conjunction with the tuned circuits of the broadcast receiver to provide the best setting as regards freedom from interference and maximum signal strength. Once adjusted, however, there will be no further necessity to carry out any adjustment other than the setting of the broadcast tuned circuits to the desired long-wave setting. It must be emphasised, however, that the broadcast receiver must have at least one H.F. stage to enable the converter arrangement to function.

As may be seen from the illustrations, all the components are accommodated on a chassis

measuring 10in. by 8in., and, to facilitate efficient and simple wiring, the coil unit is mounted with the switch control knob on the right-hand side.

The other components may be accurately placed from the wiring diagram, and wiring should be carried out with a heavy gauge of wire. The various points shown on the right-hand side of the theoretical circuit may be provided with plugs or spade-ends according to the method which is decided upon for each individual case. Thus, a wander plug should be provided at the end of the flexible lead marked "Adapter," so that this may be inserted in the anode socket of the valveholder in the broadcast set. The "Converter" lead may be provided with a spade or pin plug, according to the type of aerial terminal which is fitted to the broadcast receiver, whilst the L.T. and H.T. leads may be joined, as desired, to the terminals or the batteries of the broadcast equipment.

When mounting the brackets for the volume control and reaction condenser, care must be taken that the fixing screws do not project and make contact with the metal surface on top of the chassis—otherwise these two components will be short-circuited to earth and the apparatus will not function.

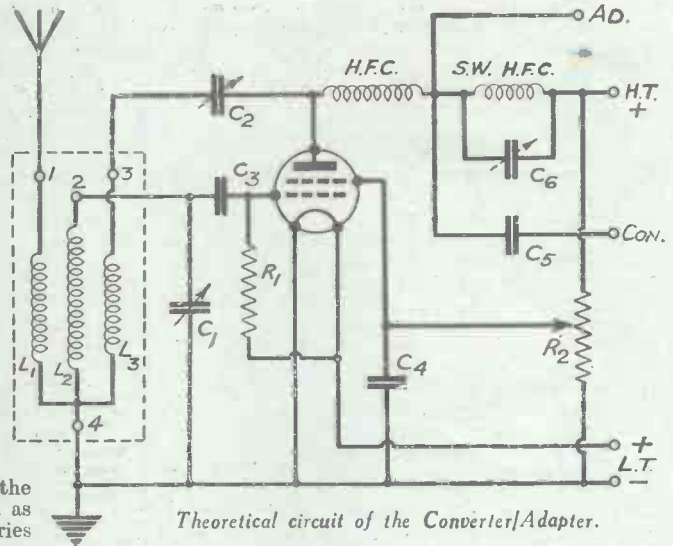

Theoretical circuit of the Converter/Adapter.

Testing

When wiring is complete, the Hivac S.G.215 valve should be plugged into the valveholder, and the arm of the potentiometer should be turned to the extreme right. The aerial lead should be removed from the broadcast receiver and inserted into the aerial socket on the unit and a lead should also be joined between the earth terminal on the unit if a separate H.T. battery is to be employed. If the H.T. battery is to be common to both the receiver and the unit, however, no earth connection need be made to the unit, as this will be automatically obtained through the filament wiring.

To avoid the necessity for switching the L.T. circuit it may be found desirable to connect the L.T. leads from the unit to the filament terminals on one of the valveholders in the broadcast receiver, when the switch on the latter will automatically control both pieces of apparatus. Tuning should be carried out slowly, even although a slow-motion dial is provided, and the coils which are plugged into the tuning unit will enable any desired range to be covered, the change from one range to another being carried out by means of the switch on the coil chassis. If reaction is found to be erratic in its behaviour, the arm of the potentiometer should be turned and so adjusted that smooth control is obtained throughout the range, although in the event of any peculiar behaviour the provision of a variable

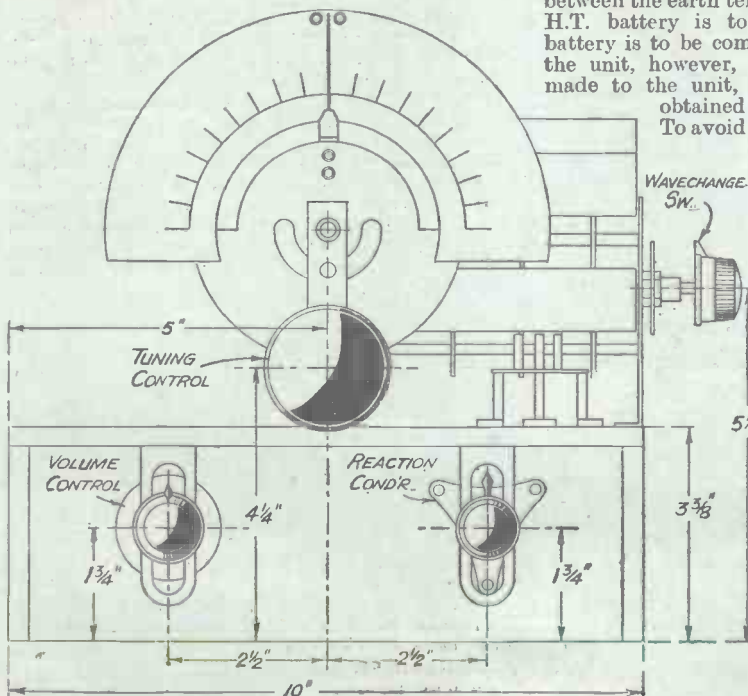

Panel-drilling diagram of the Converter/Adapter.

adjustment for this part of the circuit enables optimum results to be obtained under all conditions.

It will be noticed that the Coil Unit as specified for this Converter-Adapter is provided with five short-wave coils, but it is quite possible for the selection of the coils to be so modified that the Adapter may be used also for the reception of broadcast signals. In such a condition, of course, the headphones would be connected in series with the H.T. lead and the S.W. choke. The device thus becomes a simple detector stage and may even be used for the reception of signals on all wavelengths, the necessary change from one band to another being accomplished by means of the control knob on the Bulgin Coil Unit. In this case the choice of coils for the Unit should be made as follows: No. S.W. 23, S.W. 24, S.W. 25, S.W. 28 and S.W. 29. The last two mentioned coils cover the medium and long broadcast wave-band.

Wiring Diagram of the Short-Wave Converter-Adapter

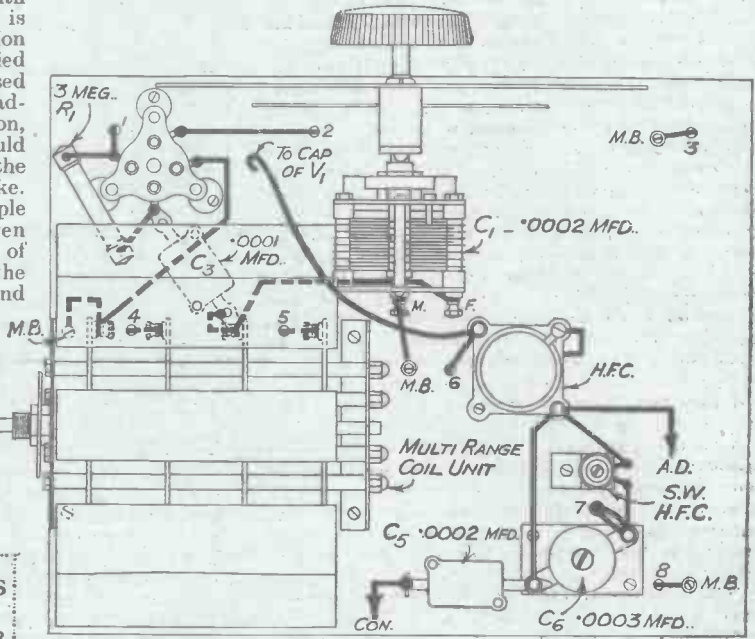

LIST OF COMPONENTS FOR SHORT-WAVE CONVERTER / ADAPTER

- One Short-wave Tuner Chassis, Type S.W.22 .. Bulgin
- One Set Short-wave Coils, Types S.W.23, 24, 25, 26 and 27 .. Bulgin
- One .0002 mfd. S.W. Tuning Condenser, Type T.R.C. 32 (C1) .. B.T.S.
- One Slow-motion Tuning Dial, Type 973 .. Eddystone
- Three fixed condensers:
 - One .0001 mfd., Type M (C3)
 - One .0002 mfd., Type M (C5)
 - One .1 mfd., Type 250 (C4)
 } T.C.C.
- One Volume Control, 100,000 ohms (R2) .. B.T.S.
- One .0002 mfd. Reaction Condenser, Type RC.32 (C2) .. B.T.S.
- One H.F. Choke, Type H.F.P. .. Wearite
- One Short-wave H.F. Choke, Type H.F.1 .. Wearite
- One Mica .0003 mfd. pre-set Condenser (C6) .. J.B.
- One 4-pin Valveholder, Type V7 .. Clix
- One Socket Strip (A. and E.) .. Clix
- Two Component Mounting Brackets .. Peto-Scott
- One Metaplex Chassis 10in. by 8 in. .. Peto-Scott
- One S.G.215 Valve .. Hivac
- Wanderplugs (see text) .. Clix
- Flex, Connecting Wire, Screws, etc. ..

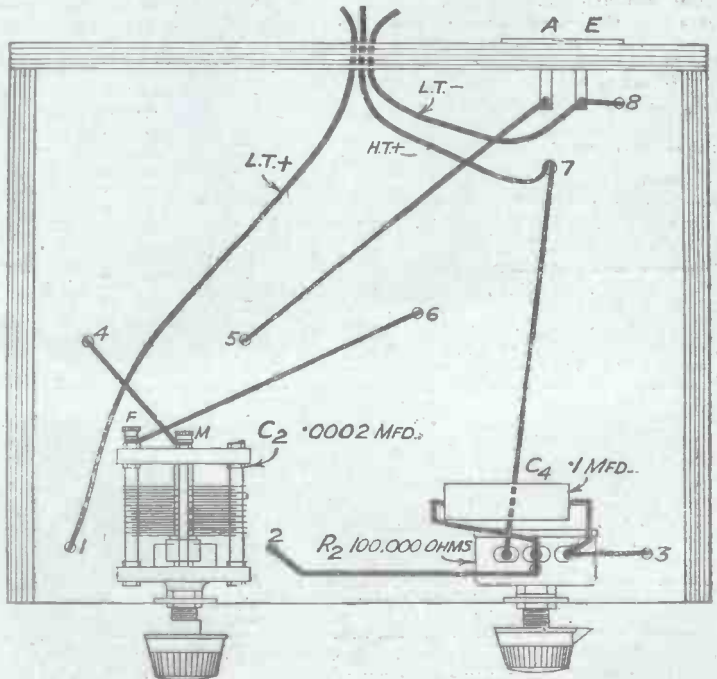

An Ultra-Short-Wave Converter

THIS piece of apparatus can only be employed with a broadcast receiver employing one or more H.F. stages, although if desired it could be incorporated in a complete receiver built especially for short-wave reception. To obtain maximum results at least two H.F. stages should be employed, and these act, when used in conjunction with this apparatus, as intermediate-frequency stages, and are followed by the detector and output stages. As may be seen from the theoretical diagram, two valves are employed, one acting as anode-bend detector (for which the most suitable negative bias may be selected by means of a flexible lead), and the other acting as an electron-coupled oscillator. For tuning purposes separate air-spaced coils are employed, and two of these are employed respectively as aerial and grid coils for the first detector, whilst the remaining coil is tapped to provide the necessary oscillatory circuit. It will be seen in the diagram that the three coils are arranged in a line, with a small space separating coils 1 and 2, but with a larger space separating coils 2 and 3. This latter separation is critical, and will require some experiment in order to select the optimum coupling between the two coils. Consequently, when constructing the unit the first two coils should be attached to the chassis by means of fixing screws through the centre hole, but the third coil should be left unattached until the apparatus has been tested and the best position found. For tuning purposes a slow-motion dual-speed dial is employed in the oscillator section, and a simple knob and pointer for the other tuned circuit. This separate tuning arrangement has been chosen in preference to a ganged tuning adjustment, as it enables the two circuits to be adjusted to the optimum setting on all ranges.

The Intermediate Frequency

A special Bulgín I.F. unit is employed in the anode circuit of the detector valve, and this is tuned by means of a fixed .0003-mfd. condenser to approximately 160 kc/s, and, therefore, the broadcast receiver with which the unit is employed must be tuned to that frequency. If a complete receiver is being built, however, the I.F. unit could be dispensed with and a special I.F. transformer used in its place. The arrangement of the circuit is such that no form of instability should arise, and maximum results should be obtained on the lowest wavelength covered by the S.W. 31 coil and the 15-mmfd. tuning condenser. This will be in the neighbourhood of 6 or 7 metres, but will vary according to the aerial-earth conditions. Some experiment may be found necessary in order to obtain an aerial system which will permit of good reception on the very lowest wavelength, and this point should be borne in mind if it is found that the set does not prove "lively"

at the minimum setting of the tuning condenser. One of the special aerials described in the section of the book dealing with aerial systems will prove very suitable, and if reception is desired at a particular wavelength a "tuned" aerial should be used. One having a total length of half the wavelength will prove suitable. This point should be borne in mind when considering the use of the apparatus for television reception on the ultra-short waves.

Construction

The constructional work is exceedingly simple, the only part which might occasion difficulty being the correct relation of the parts. If, however, the wiring diagram is carefully examined whilst construction is proceeding it should not be found difficult to obtain a sufficiently accurate layout to ensure good results when first switching on. A small part of the chassis is cut away to accommodate the slow-motion dial, although, if desired, a larger type of mounting bracket could be employed for the condenser, and the dial permitted to rest on the upper surface of the chassis. As already mentioned, only two of the coils are screwed to the chassis in the preliminary stage, and the two valveholders are mounted immediately behind coils L2 and L3. These holders are of the new Clix pattern, and enable the wiring to be kept as short as possible. The small fixed condensers and two of the chokes are suspended in the wiring and are not attached in any way to the chassis. Consequently, thick wire should be used for connecting purposes, and some care is required to cut the lengths of wire so that the components are held rigidly and do not move under the influence of vibration whilst the apparatus is in use. This particularly applies to the choke which is joined to the anode of the oscillator valve, but if a thick

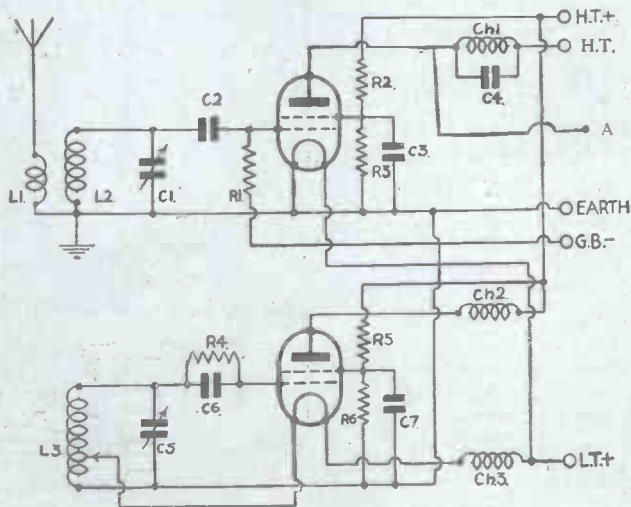

Theoretical diagram of the U.S.W. Converter.

length of wire is provided with a loop at the end and cut correctly, it will attach firmly to the cap on top of the valve and will remain in position when the valve is removed.

Using the Converter

To use the Converter, the aerial and earth leads are removed from the broadcast receiver and are connected to the Converter sockets. If the broadcast receiver employs a series aerial condenser, a lead is simply connected between the aerial terminal and the junction of the anode and Ch. 1. If no series aerial condenser is in use, a fixed condenser of .0002 mfd. is joined in series with the aerial terminal and the point above mentioned. The crocodile clip is fastened to the second turn from the earthed end of coil L. 3.

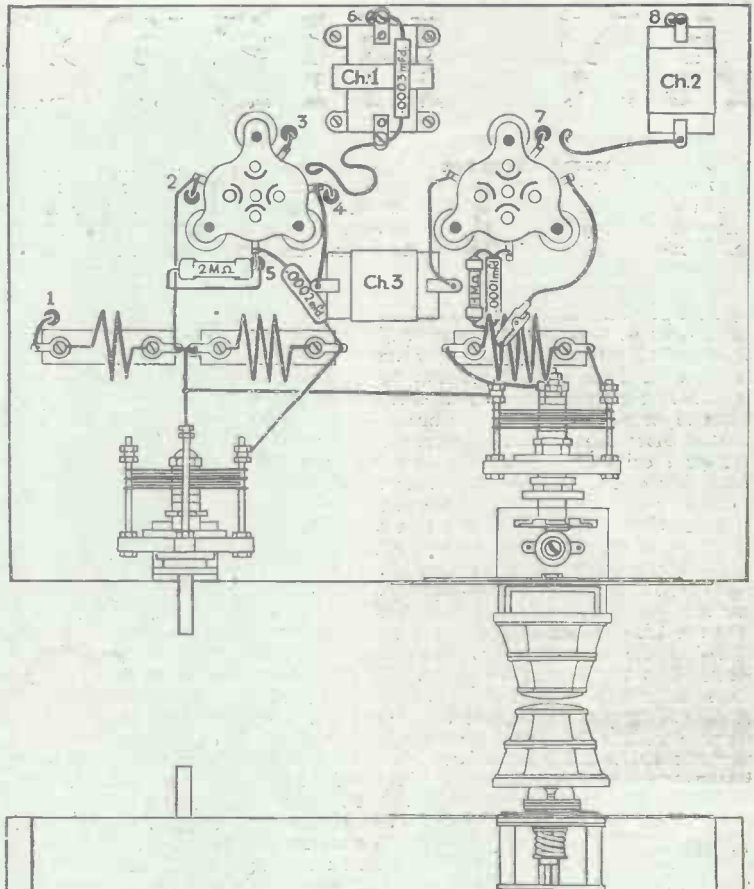

LIST OF COMPONENTS FOR THE ULTRA-SHORT-WAVE CONVERTER

- Three U.S.W. Coils, Type S.W. 30, 31, and 33 (Bulgin).
- Two 15 mmfd., Type 900, Microdensers (Eddy-stone).
- One Slow-motion Drive, Type Dual-ratio (J.B.).
- One Pointer Knob and Dial, Type 1027 (Eddy-stone).
- Five Fixed Condensers (.0001 mfd., .0002 mfd., .0003 mfd., two .1 mfd. (Bulgin).
- Six 1-watt Resistors (30,000, 40,000, two 50,000, 100,000, 2 meg-ohms) (Erie).
- Two Valveholders, Type V7 (4-pin) (Clix).
- One S.W. Choke Unit, Type S.W. 50 (Bulgin).
- Two Short-wave H.F. Chokes, Type H.F. 14 (Bulgin).
- One Terminal Strip (Aerial and Earth) (Clix).
- One Crocodile Clip, Type C.R. 5 (Bulgin).
- Two Brackets (Peto-Scott).
- Two Type S.G. 215 Valves (Hivac).
- One 10in. by 8in. Metalplex Chassis (Peto-Scott).
- Wanderplugs (see Text) (Clix).
- Connecting wire, screws, etc.

For Theoretical Circuit see page 13

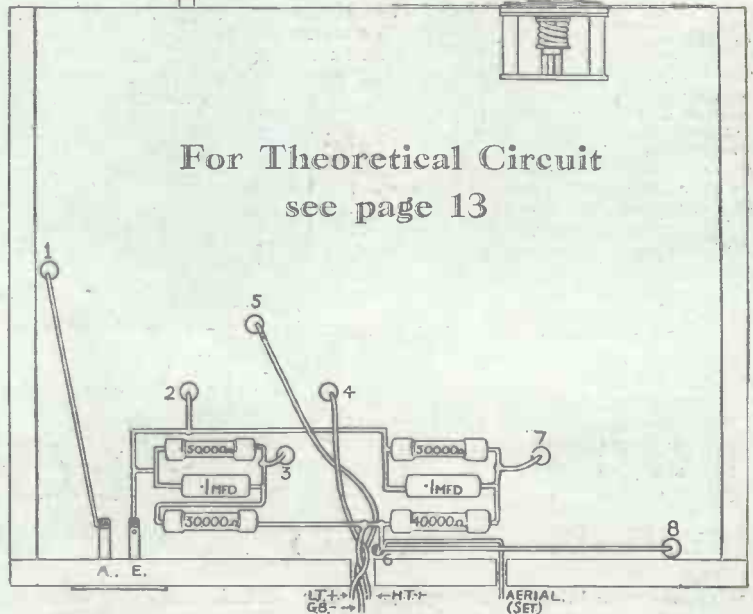

Top and underneath wiring plans of the Ultra-Short-Wave Converter.

AN HISTORIC ATTAINMENT



This startling new design, bristling with important improvements on orthodox practice, marks a new peak of high achievement in Speaker technique. It enables the "quality" enthusiast to obtain, at reasonable cost, a "laboratory" standard of reproduction previously only obtainable at almost prohibitive expense.

Amongst the "1936 Stentorian's" innumerable technical advantages the following are outstanding. Each in itself is a marked advance. Each takes an important part in bringing a new high fidelity and volume.

- New and larger "Mansfield" magnet, giving a flux density previously unequalled in a commercial instrument.
- New micro-accurate construction, providing better sensitivity and cleaner reproduction.
- Improved "Microloade" matching device, section-wound and paper interleaved.
- Hand-made cone, for improved attack and freedom from frequency-doubling and focusing.

Read Mr. Camm's message, and then hear a "1936 Stentorian" for yourself. You will be amazed at the new quality it gives!



"Every constructor owes your engineers a debt of gratitude for your 1936 Stentorian. Once again they have beaten their best—excellent precision workmanship, even wider frequency response, higher degree of magnetic flux, entrancing tone at which the most critical could not cavil—and, above all, outstanding sensitivity.

"Can there be a better speaker?"

1936 STENTORIAN PRICES:

Senior Chassis	42/-
Junior	32/6
Eaby	23/6
Midget	17/6
Stentorian Duplex	84/-

H. J. Camm

Hear for yourself—on your own set if possible—the reason for Mr. Camm's enthusiasm. You will be struck by the magnificent volume and the new cleanness of reproduction. You will notice clear top notes and a strikingly colourful realism of which you never thought your set capable. Ask your Dealer to-day or write for leaflet.

1936 STENTORIAN PERMANENT MAGNET MOVING COIL SPEAKERS

Whiteley Electrical Radio Co., Ltd., Radio Works, Mansfield, Notts

Sole Agents in I.F.S.: Kelly and Shiel, Ltd., 47, Fleet Street, Dublin.

Pictorial
Views of
The Ultra-
Short-Wave
Converter

Theoretical
Diagram appears
on page 13

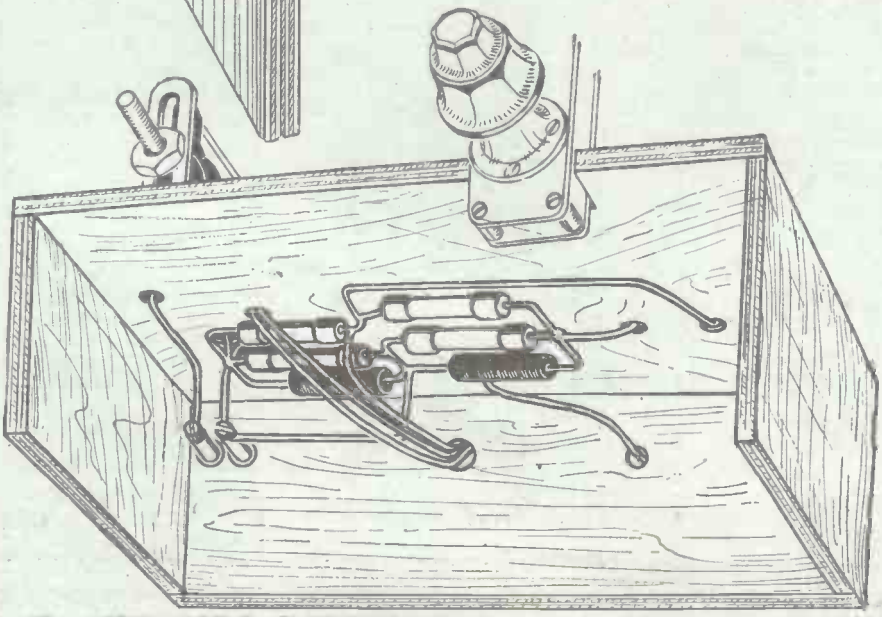
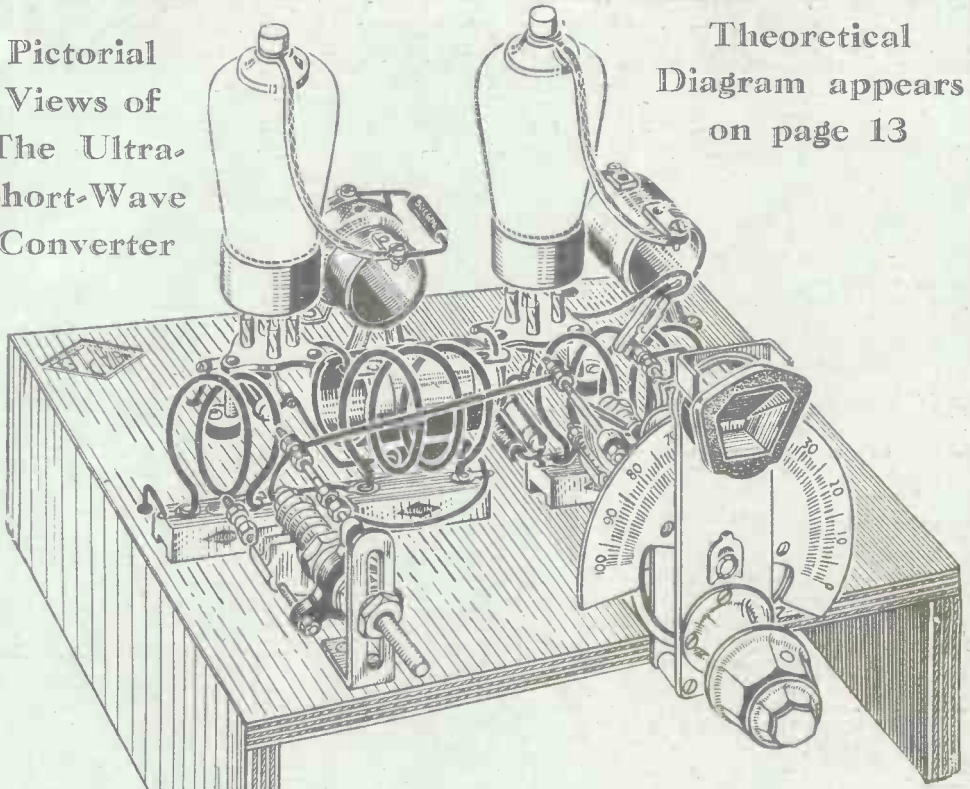

PETO-SCOTT PILOT AUTHOR KITS

Exact to Specification

IMMEDIATE DELIVERY of everything radio, **ELIMINATORS, SPEAKERS, SETS, PICK-UPS, GRAMO MOTORS, KITS, etc., CASH, C.O.D., H.P. PILOT AUTHOR KITS** featured in all journals are only obtainable from Peto-Scott. Send for detailed lists of parts. Any item supplied separately. Orders over 10/- sent C.O.D.—carriage and post free.

ULTRA SHORT WAVE SUPERMET CONVERTER • SHORT WAVE THREE

KIT "A" Cash or C.O.D. Carriage Paid **£2:5:0**
 Author's Kit of first specified parts, less valves and cabinet.
Balance in 11 monthly payments of 4/3

	YOURS FOR	3/6
	£ s. d.	
Peto-Scott Adaptor Cabinet, Type U8		15 0
1 Peto-Scott Ready-drilled Metaplex Chassis		3 0
2 Edystone microdeners		7 6
2 valves as specified		1 1 0
1 set of 3 Bulgin S/Wave Coils		7 0

FINISHED INSTRUMENT assembled with first specified parts. In cabinet, ready wired and tested, ready for use. Cash or C.O.D. Carriage Paid **£4/17/6**, or 12 monthly payments of 9/0.

SHORT WAVE ADAPTOR-CONVERTER

KIT "A" Cash or C.O.D. Carriage Paid **£3:16:6**
 Author's Kit of first specified parts, less valves and cabinet.
Balance in 11 monthly payments of 7/-

	YOURS FOR	7/-
	£ s. d.	
Peto-Scott Adaptor Cabinet, Type A C.		15 0
1 Peto-Scott Ready-drilled Metaplex Chassis		3 0
1 specified valve		10 6

FINISHED INSTRUMENT, assembled with first specified parts. In cabinet, ready-wired and tested for use. Cash or C.O.D. Carriage Paid **£5/19/6**, or 12 monthly payments of 11/0.

IT'S QUICKER BY POST

KIT "A" Cash or C.O.D. Carriage Paid **£3:19:6**
 Author's Kit of first specified parts, including Peto-Scott Ready-drilled Metaplex Chassis less valves, cabinet and speaker.
Balance in 11 monthly payments of 7/3

	YOURS FOR	7/-
	DOWN	
	£ s. d.	
1 set of 3 specified valves, 18/9		3 0
1 Peto-Scott Ready-drilled Metaplex Chassis		13 6
1 set of 3 B.T.S. S/W coils		9 6
1 J.B. tuning condenser with S/M dial		1 3 6
1 W.B. Stenorian Baby Speaker		3 0

1 Peto-Scott S.W. 3 cabinet. Walnut veneered. Specially constructed and ready drilled to take your Short Wave 3, 21/- Carriage 2/6 extra.

READY SHORTLY! No. 1 of "The Short Wave Constructor"

the new 3d. B.T.S. Magazine for S. W. enthusiasts. Pages of fascinating constructional articles.

SEND COUPON FOR YOUR FREE COPY!

PETO-SCOTT Co., Ltd., 77 (S.W.B.), City Road, London, E.C.1.
 West End Showrooms: 62 (S.W.B.), High Holborn, London, W.C.1.
 Please send me FREE, No. 1 of "The Short-Wave Constructor" when published. I enclose 3d. in stamps to cover postage.

NAME

ADDRESS

S.W.B.

JUST WHAT YOU WANT



CLIX "MASTER" PLUGS.

There are now 5 types to choose from. Two for H.T. and C.B. for general plug and socket work. One for heavy duty, such as A or E contacts. One for Power work and a 5 amp. model. Prices from 1½d. each.



CLIX SPADE TERMINALS.

There are 3 sizes to choose from. A large and a small type for accumulator or general contact work and a heavy duty type for taking A or E leads direct to set without breaks or joins. Prices from 1½d. each.



CLIX PANEL TERMINALS.

Extremely robust and soundly made. Hexagonal shoulder, greatly facilitates mounting. Insulated and non-removable head. Provision for secure, solderless connection. Clear markings. Price 4d. each.

CLIX CONNECTION STRIPS. For all plug and socket contact needs. A-E or L-S., 6d. each. Solid plugs for same, 2d. each.

Two New Folders
 "N.B." Now Ready.

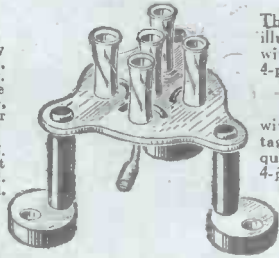

Whatever your needs in Terminals, Plug or Socket contacts Clix offers you 26 different types of perfect contact components to select from. When it comes to Valve-holders, Clix have the most complete range obtainable. The Chassis types include Standard—"Airsprung"—Continental and American. Low-loss, ceramic base types for ultra or short-wave work, and a most efficient Baseboard type with ebonite leg supports specially designed for use with Short-wave Radio and Television apparatus.

VALVEHOLDERS.

The Clix Chassis Valveholder illustrated is a low-loss type with ceramic base.
 4-pin, 10d. 5-pin, 11d.

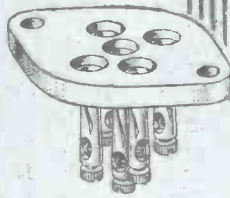

BASEBOARD TYPE.

with specially turned one-piece tagged sockets and highest quality ebonite leg supports.
 4-pin .. 1/9 5-pin .. 2/-

ALL THESE CONTACTS SPECIFIED BY MR. F. J. CAMM.



LECTRO LINX LTD., 79a, Rochester Row, London, S.W.1.

A SHORT-WAVE THREE-VALVER

THIS little receiver has been designed for general use on any short-wave band, and is just as effective on 13 metres as on 130 metres. The construction throughout is on the simplest possible lines consistent with efficiency, whilst operation is particularly straightforward. Looking at the circuit diagram it will be seen that the three valves are arranged as H.F., detector, and power; it is also evident that the aerial circuit is aperiodic, which means that it does not require to be tuned. In consequence, there is only one tuned circuit, this being the H.F. transformer coupling used between the first two valves. This is tuned by means of a .00015-mfd. special short-wave condenser which is controlled through a slow-motion drive. Reaction is provided, and the detector valve is coupled to the L.F. amplifier by means of a resistance-fed L.F. transformer.

'Phones on Two Valves

An interesting feature of the detector anode circuit is the provision of 'phone terminal sockets by means of which the first two valves can be used alone when loudspeaker reception is not required. By keeping the coupling and decoupling resistances in circuit just as they are when all three valves are in use, one is certain of maintaining the optimum anode-circuit load when 'phones are used.

To prevent the passage of H. F. currents into the L.F. stage a "stopper" resistance is included in the grid lead to the last valve. An additional refinement, is the inclusion of a fixed condenser between the anode of the output valve and earth to by-pass any H.F. which might be picked up by the speaker leads and which would cause instability.

Grid bias is obtained automatically by the voltage drop across a 300-ohm resistance which is included in the negative high-tension lead. This provides the correct bias at all times, regardless of the state of the H.T. battery or of its voltage. To prevent the introduction of instability by this resistance,

a 25-mfd. electrolytic by-pass condenser is used, this being of the new tubular type.

Construction

The whole receiver is built on a metallised chassis, which tends to prevent hand-capacity and similar troubles, and also simplifies the wiring by making it possible to take "earth-return" leads direct to the chassis by means of wood screws or small bolts. The first step is to drill the chassis to receive the valve and coil holders and the terminal-socket strips, the latter being mounted on the rear upright member. The valveholders are of the ceramic type, and have very high insulation properties combined with low dielectric losses. The holes for the valveholders are 1 in. in diameter, and that for the coil-holder is 1½ in.; holes for the terminal strips are made by drilling pairs of ⅜ in. holes and cutting away the wood between them with a pad saw or a chisel. It might be mentioned that two of the twin terminal-socket strips are marked L.S., although one of them is really intended for taking 'phone connections.

After the holes mentioned have been drilled the components can be mounted in them, when the three component brackets may be attached in the positions indicated in the wiring plan. The next step is to mount the L.F. transformer, the two type BB condensers, the fuse holder, the variable condensers and switch. That done, the wiring can be carried out using insulated connecting wire, and keeping all leads as short and direct as possible. Notice that some of the leads pass through the chassis, and ¼ in. holes are drilled for them; these may be made as the wiring proceeds, so that the best positions can be more easily determined. Notice that the lead to the screening grid of the first valve is screened by means of metal braiding, which is connected to the chassis by means of a small metal clip. Lastly the flexible battery leads should be attached and the wander plugs and spade terminals fitted to these.

(Continued on page 20)

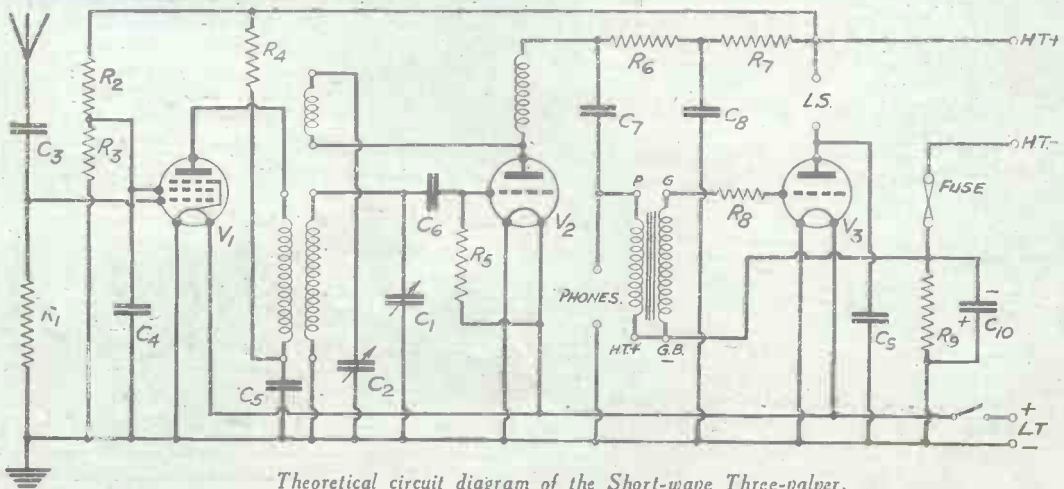

Theoretical circuit diagram of the Short-wave Three-valver.

LIST OF PARTS FOR S.W. THREE

- One Metaplex Chassis, 10in. by 8in. Peto-Scott
- Three 4-pin S.W. Valveholders. Clix
- One 6-pin Coil Base Chassis mfg. Type S.P.B. B.T.S.
- One set of 6-pin coils, Types S.P.A. C. & D. B.T.S.
- Nine 1-watt Metallised Resistances: 5,000 ohms (R.4), 20,000 ohms (R.7), 30,000 ohms (R.6), 30,000 ohms (R.2), 50,000 ohms (R.3), 100,000 ohms (R.8), 3 meg-ohms (R.5), .25 megohm (R.1), and 300 ohms (R.9) Dubilier
- Five Tubular Condensers: Two .0001 mfd. (C3 and C6), Two .1 mfd. (C4 and C7) One .001 mfd. (C9) Dubilier
- Two Fixed Condensers: 1 mfd (C5), and 2 mfd. (C8) Dubilier type BB
- One 25 mfd. Electrolytic Condenser (C10) Dubilier type 3013
- One .00015 mfd. Tuning Condenser (C1) J.B. "Short-wave Special"
- One Baseboard-Mounting Disc Drive J.B.
- One .00015 mfd. Reaction Condenser (C2) J.B. "Midget"
- One Short-wave H.F. Choke, Type 103 B.T.S.
- One 1:5 Niclet Transformer Varley
- One 60 m/a Fuse & Holder Eulgin
- Three Terminal Strips, A & E, L.S. & L.S. Clix
- One on-off Switch, Type S80 Bulgin
- Two Spade Terminals L.T.+ & L.T.- Clix
- Three Component Brackets. Peto-Scott
- Two Wander-plugs, H.T.+ , H.T.- Clix
- Connecting wire, short length screening braid, screws, flex, etc.
- One 2-Volt H.T. Battery. Accumulator.
- Three Valves, One Stentorian Loudspeaker, W.B.
- One D210, One P220 Hivac

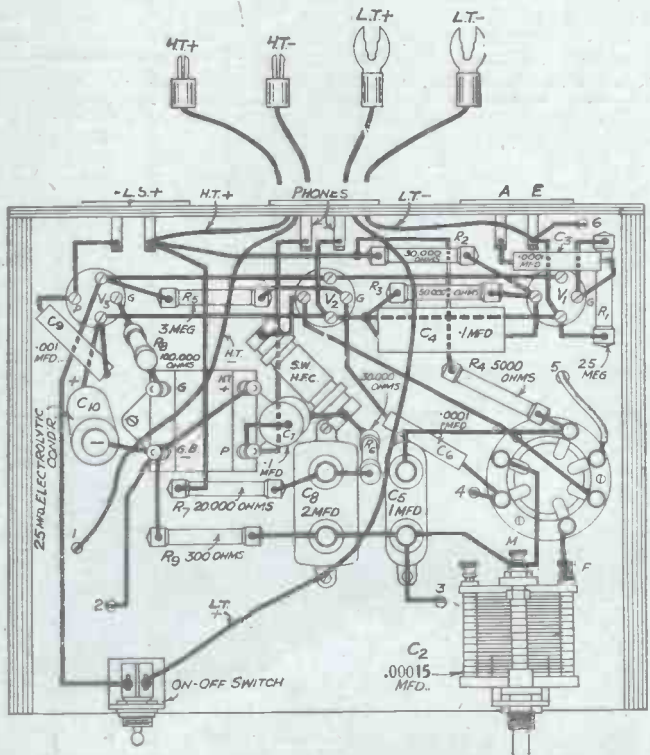
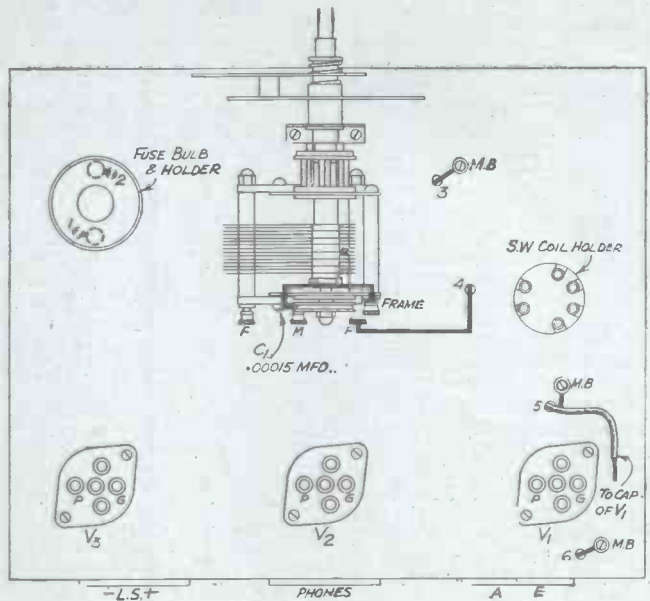

Top and underneath wiring plans of the Short-wave Three.

*(Continued from page 18)***Simple Operation**

It only remains to insert the valves and a suitable coil—according to the wavelength range it is desired to cover—and to connect the batteries. The H.T. battery should for preference have a voltage of 120, although a lower voltage can be used; the H.T. positive lead should be plugged into the socket giving the maximum voltage, and the negative wand plug inserted into the appropriate socket. After switching on, the reaction control should be advanced until the receiver is just on the verge of oscillation, this being indicated by a faint “breathing” sound. The tuning knob can then be rotated until a signal is tuned in. As the tuning control is varied it might be found necessary to make slight reaction adjustments so as to keep the set as near to the oscillation point as possible, without it actually breaking into self-oscillation. This applies to the reception of telephony transmissions, but for morse the set must be actually oscillating, when signals will appear as a series of “chirps.”

When it is wished to cover other wavelength ranges the coil must be replaced by others of suitable type, and the constructor might desire to have a full set of coils. In the first place, however, it will be found that coils for the 20-metre and 31-metre stations are most useful, as the majority of the available transmissions are near to these wavelengths. As, however,

coils for wavelengths up to 100 metres cost only 4s. each, it is by no means an expensive matter to obtain four or five so that any required short-wave station will come within the wavelength range.

As with all short-wave receivers the best aerial is a vertical wire about 20ft. long, but the ordinary broadcast aerial, either external or indoor, will yield satisfactory results.

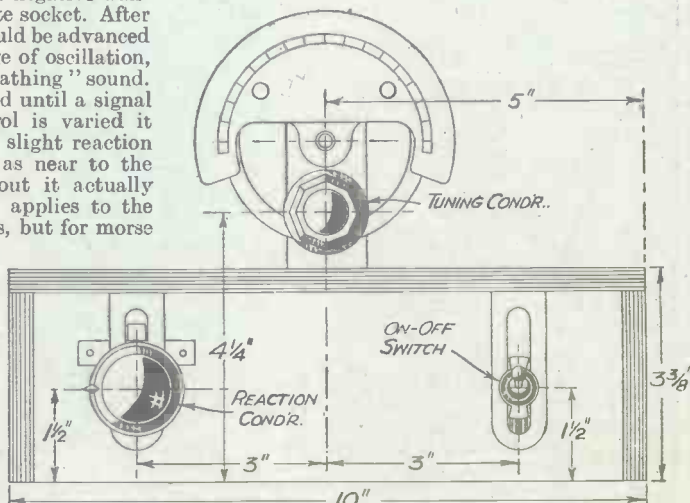

Front of panel layout of the Short-wave Three-valver.

DO YOU GET AMERICA OR AMERICA?

Do you really hear Paul Whiteman himself playing the famous “Rhapsody in Blue” or do you put up with a dim travesty? Does Rudy Vallee sing to you or just make inarticulate sounds?—It all depends on your components. If you use the special Ultra-Short-Wave components designed by Varley, you will hear the transatlantic programmes in all their original glory.

Write to Varley of Woolwich for free illustrated catalogue and state your requirements.

Varley

OLIVER PELL CONTROL, Ltd., Bloomfield Road, Woolwich, S.E.18. Telephone: Woolwich 2345

THE INTERNATIONAL "Q" CODE

Signal	Question	Answer
QRA	What is the name (address) of your station?	The name (address) of my station is
QRB	How far are you from my station approximately?	I am approximately from you.
QRD	Where are you going?	I am going to
QRE	What is your nationality?	My nationality is
QRF	Where do you come from?	I come from
QRG	Will you give me my exact frequency in kc/s?	Your exact frequency is kc/s.
QRH	Does my frequency vary?	Your frequency varies.
QRI	Is my note steady?	Your note varies.
QRJ	Are you receiving me badly?	I cannot receive you.
	Are my signals weak?	Your signals are too weak.
QRK	Are you receiving me well?	I receive you well.
	Are my signals good?	Your signals are good.
QRL	Are you busy?	I am busy. Please do not interfere.
QRM	Is reception interfered with?	Reception interfered with.
QRN	Are you troubled by atmospherics?	I am troubled by atmospherics.
QRO	Must I increase power?	Increase power.
QRP	Must I decrease power?	Decrease power.
QRQ	Must I send faster?	Send faster.
QRS	Must I send slower?	Send slower.
QRT	Must I stop sending?	Stop sending.
QRU	Have you anything for me?	I have nothing for you.
QRV	Are you ready?	I am ready—go ahead.
QRW	Must I advise that you are calling him?	Please advise that I am calling him.
QRX	Must I wait? When will you call me again?	Wait until I have finished with I will call you at
QRZ	Who is calling me?	You are being called by
QSA	What is the strength of my signals?	Your signals are
QSB	Does the strength of my signals vary?	The strength of your signals varies.
QSD	Is my keying correct?	Your keying is incorrect.
	Are my signals distinct?	Your signals are bad.
QSL	Can you acknowledge receipt of my signals?	I acknowledge receipt.
QSO	Can you communicate with direct or through	I can communicate with direct or through
QSQ	Must I send each word or group once only?	Send each word or group once only.
QSV	Must I send a series of V's?	Send a series of V's.
QSW	Will you send on kc/s waves of	I will send on kc/s waves of
QSX	Will you listen for on kc/s?	I will listen for on kc/s.
QSY	Must I send on kc/s without changing type of wave?	Send on kc/s without changing type of wave.
QSZ	Must I send each word or group twice?	Send each word or group twice.
QTR	What is the exact time?	The exact time is
QWX	How is the weather there?	Weather here is

The above table shows the code of "wireless shorthand" as used by radio operators, principally those transmitting from commercial stations, ships and the like. The same group of letters is sent for both query and answer, but in the latter case the question mark is not included.

THE INTERNATIONAL MORSE CODE

LETTERS:

a . —	n —
ä	ñ —
à or á	o —
b —	ö —
c —	p —
ch —	q —
d —	r —
e	s
é	t —
f —	u —
g —	ü —
h	v —
i	w —
j —	x —
k —	y —
l —	z —
m —	

FIGURES:

1 —	6 —
2	7 —
3	8 —
4	9 —
5	0 —

In official repetitions of radio telegrams, etc., figures must be rendered by the following signals, which may also be used in the text of radio telegrams written entirely in figures. In the latter case the

messages bear the service instruction: "in figures."

1 —	6 —
2	7 —
3	8 —
4	9 —
5	0 —

PUNCTUATION AND OTHER SIGNS

Full Stop
Comma
Colon —
Note of interrogation
Apostrophe —
Hyphen or dash —
Fraction bar —
Brackets —
Underline
Double dash —
Understood
Error
Cross (end of transmission)
Invitation to transmit —
Wait —
End of Work
Commencing Signal —
Separation Signal —

In order to avoid confusion when transmitting fractional numbers, the fraction must be preceded or followed, as the case may be, by the separation signal.

THIS IS NOT THE FIRST TIME

When HIVAC valves were first placed on the market, Mr. F. J. Camm, after testing them, said :-

"In actual use in standard receivers, these valves are very good. . . . Although cheap they may be highly recommended."

Quite recently, Mr. F. J. Camm chose the wonderful HIVAC "MIDGET" Valves as "the basis of design" for his "Cameo" series of Midget receivers.

To-day, Mr. F. J. Camm gives Solus Specification to HIVAC for ALL Short-wave Apparatus described in this booklet.

The types of Hivac Valves listed below include those now specified by Mr. F. J. Camm; and some other popular types which are in demand for replacing "tired" valves of other makes.

HIVAC 2-VOLT BATTERY VALVES

D.210. Non-microphonic Detector ..	3/9
L.210. L.F. Amplifier	3/9
P.220. Small Power	5/6
HP.215. H.F. Pentode type	10/6
SG.215. Screen Grid	10/6
Y.220. Medium power output pentode type	10/6

Details of the Complete range of Hivac Battery, Mains and "Midget" Valves are given in the Hivac Valve Guide "N.B." Free on request.

**HIVAC GIVE SERVICE
efficient and lasting**

*Fit Hivac and Save 25%
on your Valve costs*

HIGH VACUUM VALVE CO. LIMITED,
113-117, FARRINGTON ROAD, LONDON, E.C.1

HIVAC
THE SCIENTIFIC
VALVE

BRITISH MADE

TUNE IN TO THE WORLD

Shown here are two of our specially designed Ultra-Short-Wave condensers. They are both built in the same faultless style which has made the name of Jackson famous. Their extraordinary rigid construction gives knife-edge tuning even at the extreme ends of the waveband, and the rotor contacts of the Midget ensure complete silence and a minimum of resistance.

Write now for our illustrated brochure describing these Short-Wave components

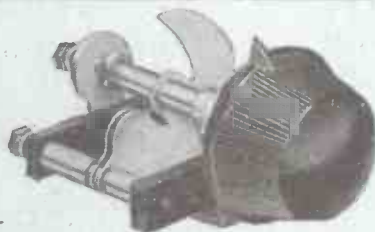

SHORT-WAVE SINGLE
Capacities 15mmf., 30mmf.,
.0004, .0001, .00015. Catalogue
Nos. 2140, 2141. Price .. **3/9**

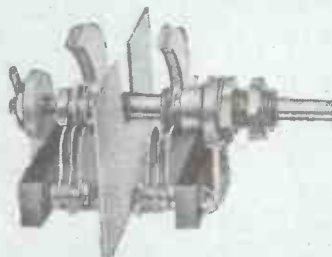

SHORT-WAVE TWIN
Designed for Ultra-Short-Wave
work. Capacities 15mmf.,
30mmf., 45mmf. Catalogue
Nos. 2147, 2148, 2149. Price .. **5/-**
Slow motion action, 1s. extra.



Jackson Brothers (London) Ltd.,
72, St. Thomas Street, S.E.1

Telephone: HOP 1837



EDDYSTONE

SHORT WAVE
COMPONENTS



LONDON SERVICE DEPOT
WEBB'S RADIO STORES
14, SOHO ST., OXFORD ST., W.

STRATTON & Co. LTD. • EDDYSTONE WORKS • BROMSGROVE ST. • BIRMINGHAM 5.