

# MAKING A BAND-PASS ADAPTOR

# Practical Wireless

3<sup>D</sup>

Published by  
**GEORGE  
NEWNES  
LTD.**

Vol. I—No. 11  
DECEMBER 3rd, 1932

Registered at the G.P.O. as a Newspaper.

## THE EMPIRE SHORT WAVE THREE!

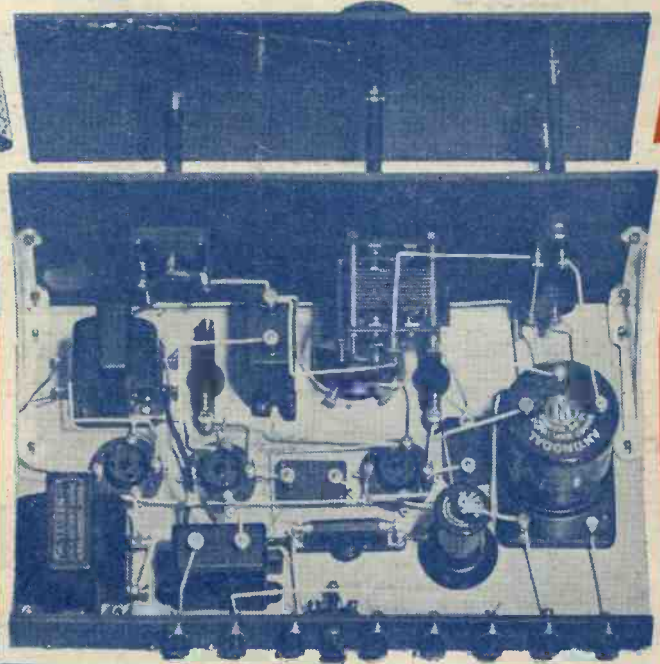

**FULL  
DETAILS  
INSIDE**

— *how to bring in more stations*  
**fit COSSOR S.G. VALVES**

**The best  
compliment  
you can pay  
a fine  
receiver**

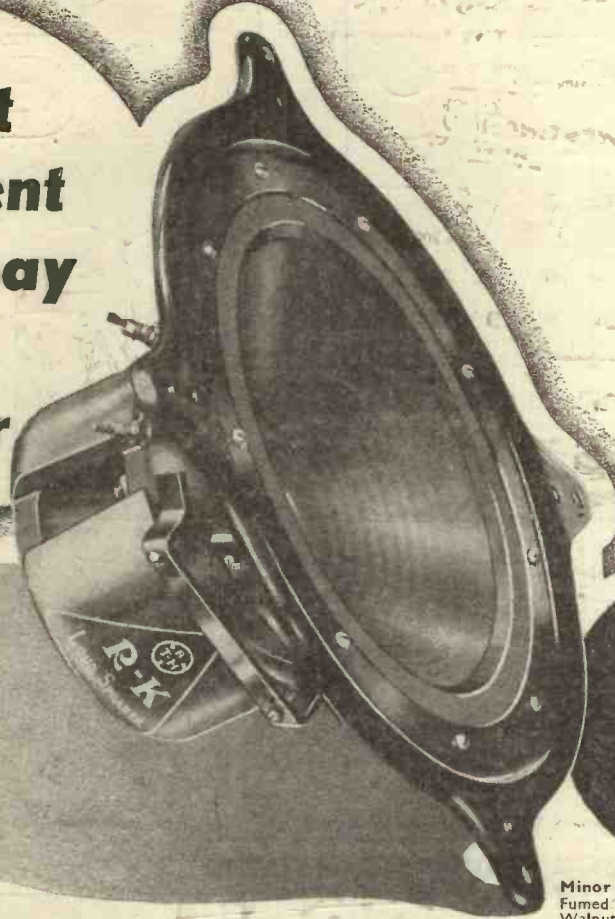

**R.K. SENIOR PERMANENT  
MAGNET UNIT is fitted in  
the Warwick and Wind-  
sor models as illustrated  
below.**

Price, Unit only - £5, 5. 0

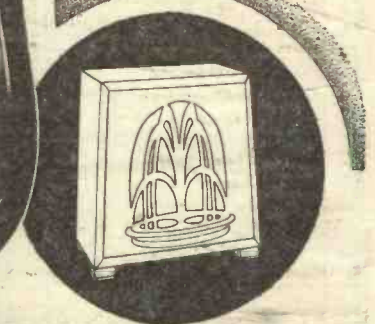

Minor R.K. Permanent Magnet Model  
Fumed Oak "ARUNDEL" model £2.17.6  
Walnut "ARUNDEL" model - £3.3.0



Senior R.K. Permanent Magnet Model  
"WARWICK" model in Oak - £8.10.0  
"WARWICK" model in Walnut £8.17.6

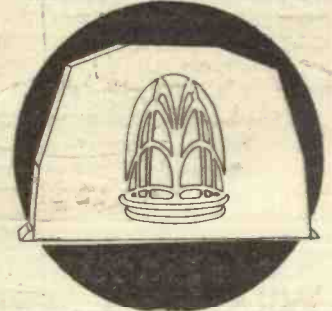

Senior R.K. Permanent Magnet Model  
"WINDSOR" model in Oak - £8.10.0  
The above-mentioned speakers are supplied  
complete with multi-ratio transformer.

You may have the best of receivers—well-designed, beautifully made, complete with Mazda valves—but an inferior loudspeaker will prevent its giving of its best. The best compliment you can pay such a set is to use an R.K. reproducer. It is the only moving-coil speaker capable of giving such balanced reproduction and fine sensitivity. Expense need place no obstacle in your way, for R.K. prices range from £2-17-6 and H.P. terms are available. All good radio dealers will be glad to demonstrate R.K.'s to you. A range of output transformers, specially designed for use with R.K.'s, is available.

B.T.H.



**MOVING COIL  
REPRODUCER**

1933 MODELS

EDISWAN RADIO 100% BRITISH

The Edison Swan Electric Co. Ltd.



155 Charing Cross Rd. London. W.C.2

## A.C. BATTERY CHARGERS



**75/- to £16 H.T. & L.T.**  
12 MONTHS GUARANTEE.

NOW is the time to install a Charging Plant

INCORPORATING  
**WESTINGHOUSE METAL RECTIFIERS**

Complete Charging Sets with Ammeter, Sliding Resistance Terminals, Plug and Flex. Ready for use. From 75/- 10 volts, 3 amps. will do from 1 to 8 cells L.T. H.T. 105/- 200 volts, 125 m/a.

ACTUAL PHOTOGRAPHS & LISTS FREE. State volts of mains & cycles.

NASH PRODUCTS LTD., STECHFORD, B'HAM(9)

## Simpson's Electric Turntable



"goes by itself."

1. Only 2 1/2" deep.
2. Sizes 10" and 12".
3. 50 Cycles, 100/150 and 200/250 volts A.C!
4. Fits any Gramophone.
5. Costs less than 1/4d. per week.
6. Correct speed of 78 revs. per minute.
7. Nothing to go wrong.
8. Anyone can fit it.

The most remarkable gramophone invention of the age—a gramophone turntable that "goes by itself." In a few minutes you can convert an ordinary gramophone into an automatic electric one. It takes little longer, following the simple instructions supplied, to convert your present Radio Set into a super Radio-gram. The total cost is only **39/6**. It lasts a lifetime with no additional cost. Ask your Dealer for illustrated leaflet and demonstration.

**SIMPSON'S ELECTRICALS, LTD.,**  
GRANGE ROAD - LEYTON - E.10.

## PIX INVISIBLE AERIAL

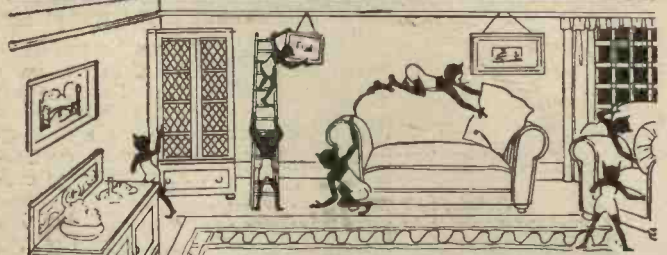

**AS GOOD AS AN OUTSIDE AERIAL—YET INVISIBLE!**

Just imagine listening in on an Aerial actually in the room, yet you cannot see it! Like Radio itself—invisible. Getting the same reception as on an outside Aerial, without unsightly poles, lead-in tubes, insulators, loose wires. Every modern set needs an Invisible Aerial.

NO WIRES. No danger from lightning, reduces Static interferences and increases selectivity! **WHAT AN AERIAL!** Just a 30ft. roll of narrow adhesive tape which you press around the room below the picture rail, wainscoting, carpet, or up the staircase—n fact, anywhere. Pull the end and it's down and leaves no mark.

**IDEAL FOR USE IN FLATS.**

Being in the form of a narrow self-adhesive strip 30ft. in length, can be fixed anywhere in a moment without tools.

**EVEN THE PIXIES CAN'T FIND IT**  
**2/-**

POST FREE Or from your Dealer. Double Length, 3/6



**P/X INVISIBLE AERIAL**  
AS GOOD AS AN OUTSIDE AERIAL

**THE BRITISH PIX COMPANY, LTD.,**  
(Dept. 316),  
118-28, Southwark Street, London, S.E.1.

# Now permanently matched!

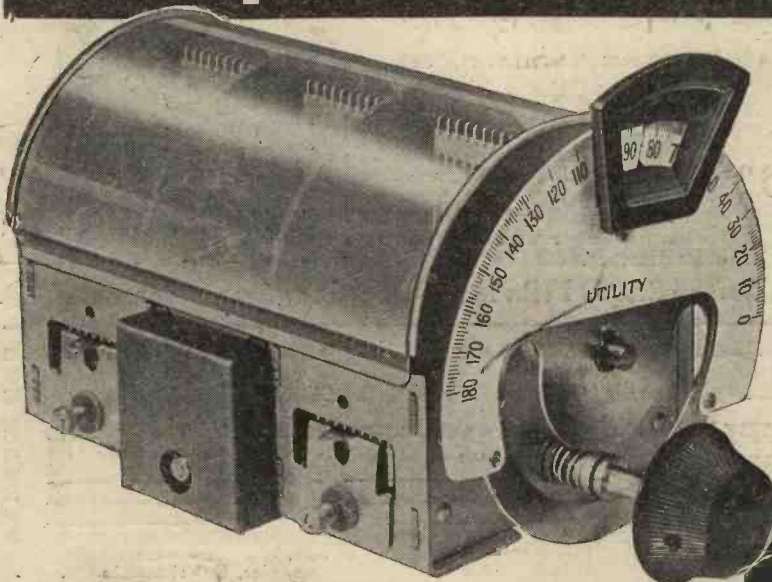

Utility was the first ganged condenser guaranteed matched to 1% accuracy. But it is not sufficient to know that your ganged condenser was accurately matched when it left the maker's factory. More important is it that the condenser should remain matched when it is functioning in your set. You can depend on the new Utility ganged condenser remaining permanently matched. But only by the Utility method of manufacture can a constant accuracy factor be assured and thus only the Utility ganged condenser is guaranteed permanently matched.

### PRICES:

	Less dial	With dial.
W313/2 2-Gang, semi-screened	15/-	17/6
W313/3 3-Gang, do.	22/6	25/-
W313/4 4-Gang, do.	30/-	32/6
W314/2 2-Gang, fully-screened	17/-	19/6
W314/3 3-Gang, do.	25/-	27/6
W314/4 4-Gang, do.	33/-	35/6

A full range of super-het. condensers is also available.

From your dealer or post free from the makers.

**WILKINS & WRIGHT LIMITED**  
UTILITY WORKS, HOLYHEAD ROAD, BIRMINGHAM.

London Agents:  
E. R. Morton, Ltd., 22, Barlett's Buildings, Holborn Circus, E.C.4.

**Utility**  
**CONDENSERS**

**BRITISH GENERAL**

**OUTPUT TRANSFORMER**



Enables the speaker to be correctly matched to the valve giving increased volume and better tonal balance. Prevents damage to the loud-speaker due to sudden switching on and off of large currents.

Price **9/6** Multi Ratio.

From all dealers or direct.  
British General Manufacturing Co., Ltd.,  
Brockley Works :: London :: S.E.4.

**Simpsons**

**ELECTRIC TURNTABLE**

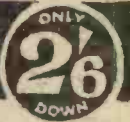

To convert your Radio Set into a Radiogram or electrify a Gramophone

No bigger or thicker than an ordinary gramophone turntable, and the motor is in the turntable itself. Set at exactly 78 revs. per minute regardless of weight of tone-arm or pick-up, silent, and it will work almost for ever without trouble or wear.

Current cost less than 1d. week.

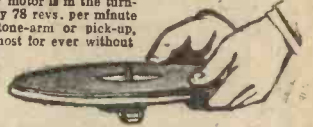

Splendidly finished and nickel plated, 12ins. or 10ins. diameter, balze covered. Weight 8lbs. Sent on 7 days' approval for only 2s. 6d. deposit if satisfied pay further 2s. 6d. at once, then 8 monthly payments of 5s. (Cash 40s. 6d. complete with flex and plug.) Please state voltage. Illus. Folder post free.

E. J. HERAUD, Ltd., Dept. P.10, Number One, Edmonton, LONDON, N.18.

Branches: 78-82, Fore St., Edmonton; 77, West Green Rd., Tottenham; 34, St. James St., Walthamstow and 139, Hertford Rd., Enfield Wash.

**WATES Rotary Converter**

**TURNING DC CURRENT TO AC**

Specially designed for radio by electrical engineers of long experience with broadcast receivers, WATES ROTARY CONVERTER offers a perfect solution to the DC problem. AC current converted from DC by this latest type Wates is actually better than that obtainable from AC mains. Ideal for supplying receivers of very high selectivity: public address amplifiers: electric sets attached to private power installations: etc. Will run for many years without attention, apart from oiling and cleaning of brushes, commutator, etc. Special silencing cabinet also makes Wates Rotary Converter quite portable.

MODEL A. For DC mains 200-250 volts, Output 80 watts AC, 220-250 volts, 50 cycles. Suitable for most sets up to 9 valves and small Radiograms. Complete with Smoothing & Silencing Box  
Converter £8 : 5 : 0. Smoothing Box 25/-. Silencing Box 40/-.

MODEL B. As above, larger output of 180 Watts, suitable for Radiograms requiring extra heavy supply. Complete with Smoothing and Silencing Box  
Converter £10. Smoothing Box 25/-. Silencing Box 40/-.

Quotations for any output or voltage by return.

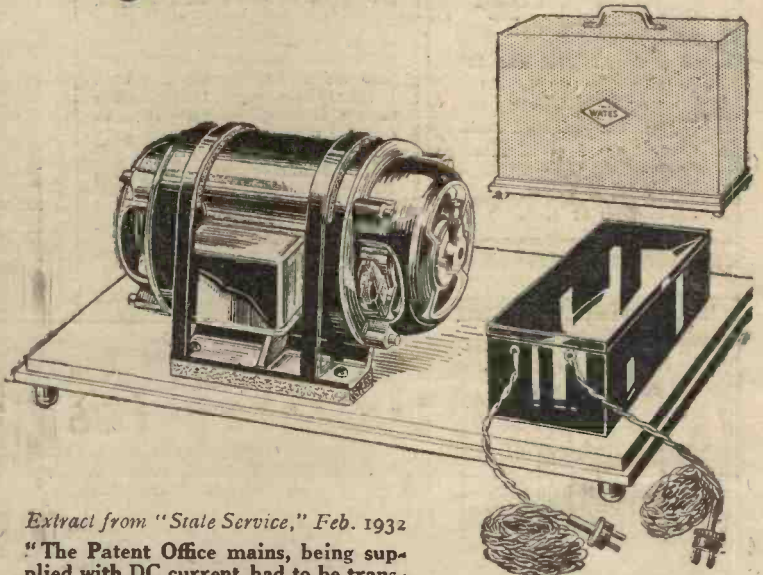

Extract from "State Service," Feb. 1932  
"The Patent Office mains, being supplied with DC current, had to be transformed into AC for the Amplifier and Radiograms. This important job was undertaken by a Wates Converter and it need only be said that this machine did its work so well and so unobtrusively that the audience were quite unaware of its presence."

**FURTHER DETAILS AND ADVICE POST FREE**

WATES RADIO LTD., 184-8, Shaftesbury Avenue, London, W.C.2.

**"NEW RADIOS FOR OLD"—FOR CHRISTMAS**

**WE BUY YOUR OLD SET & SUPPLY YOU WITH A NEW SEASON'S MODEL**

Liberal Allowances and Balance Payable by Cash or Hire Purchase

HUNDREDS OF TESTIMONIALS FROM SATISFIED CLIENTS

**EVERY MAKE OF SET, KIT OR RADIOGRAM SUPPLIED**

Complete Transactions Executed by Mail.

It will pay you to write for particulars of our amazing exchange offer, enclosing 1/3d. stamp, naming your old set and the new model you fancy. A FREE QUOTATION WILL FOLLOW.

**FREE** Wireless Set to introduce the Radialaddin Club.

Please forward this INQUIRY FORM (without obligation)

Please quote me free your allowance for the new set:

Make ..... Model and List Price .....

My present Set is: Make ..... Batteries or Mains .....

Date of Purchase ..... Original Cost of Set: .....

Balance of purchase price would be payable by me as follows:

Plan A. Whole of balance in cash.  
Plan B. Whole of balance over six, nine, twelve months.

† Delete unwanted words.

NAME (in full) (Block letters) .....

ADDRESS .....

Visit Our Showrooms

**RADIALADDIN, LTD.**

THE LARGEST RADIO EXCHANGE IN THE UNITED KINGDOM, (Dept. P.R.W.) 46, Brewer Street, London, W.1. 'Phone Gerrard 4055.

# BALANCED CAPACITY

GIVES LONGER LIFE

AND HIGHER AMPERE HOUR

EFFICIENCY



- Type E.L.9. 80 a/h capacity **12/3**  
Price - - - - -
- Type E.L.M.4. 45 a/h capacity **8/-**  
Price - - - - -
- Type E.L.S.7. 60 a/h capacity **12/6**  
Price - - - - -

● That's the secret, "balanced capacity," the newest principle in modern accumulator making.

The scientific design of the positive and negative plates which preserves exact electrical "balance" allows this accumulator to be charged more quickly, and to give a longer life per charge. Twenty-five years experience in battery building has gone to produce the Ediswan "Extra Life" cell. Here are some of the additional refinements incorporated: screwed vents, non-interchangeable and non-corrodible connectors, British made containers of clear glass and metal carriers which fit neatly round the containers.

# EDISWAN *EXTRA LIFE* ACCUMULATORS



THE EDISON SWAN ELECTRIC CO. LTD.  
155 CHARING CROSS ROAD, LONDON, W.C.2

B.204

STUDY  
AT  
HOME

YOU CAN HAVE A COLLEGE  
TRAINING IN ALMOST ANY  
CAREER FOR A FEW  
SHILLINGS MONTHLY

IN YOUR  
SPARE  
TIME

## LET ME BE YOUR FATHER

Unless you are in touch with all branches of industry you cannot see the possibilities of employment, but with our gigantic organisation we are in touch with every sphere of activity, and we know that in many trades and professions there are more vacancies than there are trained men to fill them.

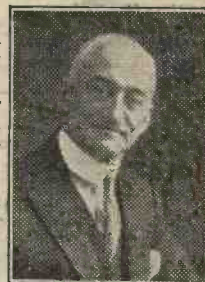

*J. Bennett*

WE DO NOT PROFESS TO ACT AS AN EMPLOYMENT AGENCY, BUT WE CERTAINLY ARE IN A POSITION TO GIVE FATHERLY ADVICE ON ALL CAREERS AND THE POSSIBILITY OF EMPLOYMENT THEREIN.

We teach by post all branches of the following vocations, and specialise in all examinations connected therewith. Our advice is always Free.

**THE MOST SUCCESSFUL AND MOST PROGRESSIVE  
CORRESPONDENCE COLLEGE IN THE WORLD**

- Accountancy Examinations
- Advertising and Sales Management
- A.M.I. Fire E. Examination
- Applied Mechanics
- Army Certificates
- Auctioneers and Estate Agents
- Aviation Engineering
- Banking
- Boilers
- Book-keeping, Accountancy and Modern Business Methods
- B.Sc. (Eng.)
- B.Sc. (Estate Management)
- Building, Architecture and Clerk of Works
- Chemistry
- Civil Engineering
- Civil Service
- All Commercial Subjects
- Commercial Art
- Concrete and Structural Engineering
- Draughtsmanship. All branches
- Engineering. All branches, subjects and examinations
- General Education
- Heating and Ventilating
- Insurance
- Mathematics
- Matriculation
- Metallurgy
- Mining. All subjects
- Mining, Electrical Engineering
- Motor Engineering
- Municipal and County Engineers
- Naval Architecture
- Pattern Making
- Police. Special Course
- Preceptors. College of
- Pumps and Pumping Machinery
- Radio Reception
- Road-making and Maintenance
- Salesmanship
- Sanitation
- Secretarial
- Shipbuilding
- Shorthand (Pitman's)
- Structural Engineering
- Surveying
- Teachers of Handicrafts
- Telephony and Telegraphy
- Transport
- Weights and Measures "Insp."
- Wireless Telegraphy and Telephony
- Works Managers

If you do not see your own requirements above, write to us on any subject

**DO NOT DELAY**  
THERE MAY BE CHANCES FOR YOU TO-DAY FOR WHICH YOU MAY BE TOO LATE TO-MORROW. EVERY DAY COUNTS IN A MAN'S CAREER.

**IT COSTS NOTHING TO INQUIRE**  
WE TEACH BY POST IN ALL PARTS OF THE WORLD  
Also ask for our New Book—FREE OF CHARGE  
**THE HUMAN MACHINE**  
Secrets of Success.

Note Address Carefully:  
**THE BENNETT COLLEGE LTD.**  
(Dept. 192)  
**SHEFFIELD**



# 70 Stations to choose from—

Grenoble (PTT)	Rabat	Brno	Bratislava	Lahti
Wilno	Dublin	Brussels No. 2	Heilsberg	Radio Paris
Budapest	Katowice	Milan	Turin	Konigs
Sundsvall	Radio Suisse	Poste Parisien	Lille	Wust'rhan
Rixia	Midland Reg.	Goteborg	London	Darenty
Vienna	Bucharest	Genoa	National	National
Brussels	Toulouse	Cardiff	Horby	Eiffel Tower
Flornce	Lwow	Bordeaux	Gleiwitz	Warsaw No. 1
Prague	Scottish Reg.	North National	Trieste	Motala
North Regional	Algiers	Tallinn	Helsinki	Moscow
Langenberg	Stuttgart	Hilversum	Nurnberg	Kalundborg
Laudesender	London Reg.	Bournemouth	Cork	Popoff
Rome	Graz	Newcastle	Fecamp	Oalo
Stockholm	Barcelona	Plymouth	Kaunas	Kiev
Moscow	Strasbourg	Swansea	Huizen	Leningrad

When you build a SKYSCRAPER THE ONLY SET YOU CAN BUILD YOURSELF EMPLOYING METALLISED S.G. VALVE, HIGH-MU DETECTOR AND ECONOMY POWER PENTODE

Here's a list of stations! Actually logged by a constructor at the first time of trying out a newly-assembled Skyscraper! What a record! What endless nights of entertainment! And everybody who builds the Skyscraper gets results like this—hundreds of appreciative letters prove it!

Never before was there such a set within the reach of the home constructor. Never before such power from any battery set. Never before so many stations as the Skyscraper brings in. It is the only set on the market that you can build yourself employing Metallised Screened-Grid, High-Mu Detector and Economy Power Pentode Valves. No factory—however well equipped—can build a better receiver. No manufacturer, however large, can produce a receiver whose results will surpass those you will get from the Lissen Skyscraper you build yourself. It is the only battery kit set that can deliver such power—yet the H.T. current consumption is far less than that of the average 3-valve set.

**GREATEST CHART EVER PUBLISHED!  
GREATEST SET EVER BUILT!**

Lissen have made the building of the Skyscraper extremely simple for you. Elaborate care has been taken to ensure your success by giving in the Skyscraper Constructional Chart such detailed instructions and such profuse illustrations that everybody, with no technical knowledge or skill at all, can build it quickly and with complete certainty of success.

You buy the Lissen Skyscraper Kit, complete with valves; a Lissen Metallised S.G., a High-Mu Detector, and a Lissen Economy Power Pentode Valve, and the price is only 89s. 6d. Or you can buy the Lissen Walnut Console Skyscraper Cabinet and Loudspeaker combined as illustrated. It holds all batteries, and accumulator and loudspeaker as well! It makes everything self-contained. A special Pentode Matched Balanced-armature Loudspeaker of great power is supplied with the cabinet, and the price of the Skyscraper Kit, complete with valves and this cabinet and loudspeaker, is only £6 5s.

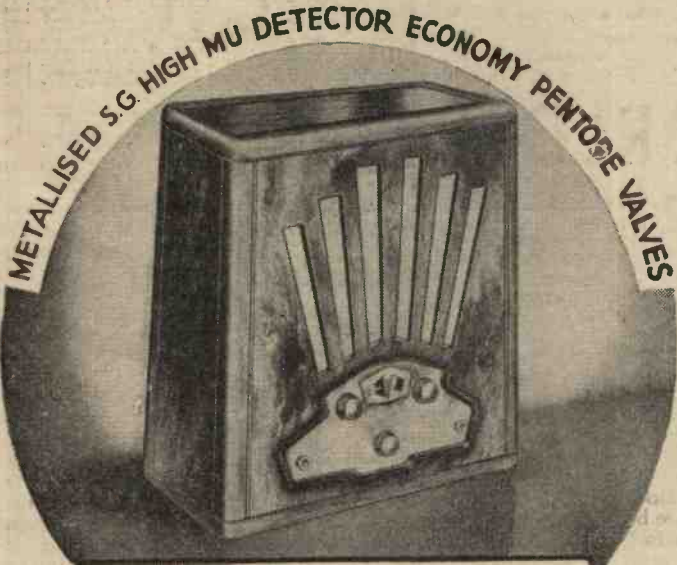

COMPLETE WITH CABINET AND LOUDSPEAKER **£65** or 11/6 deposit and 12 monthly payments of 10/6.

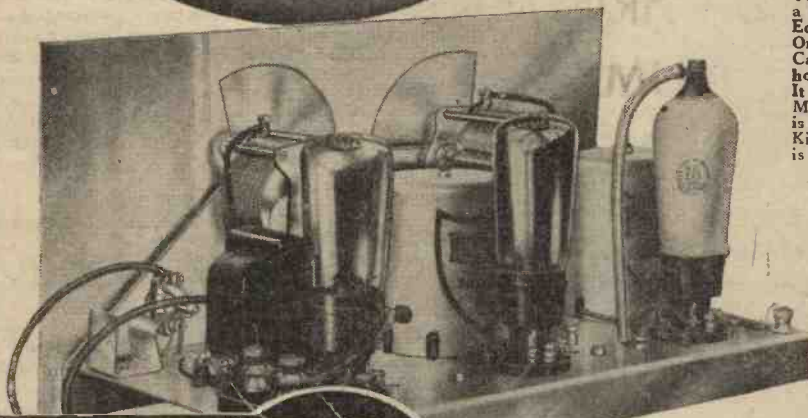

KIT COMPLETE WITH METALLISED S.G. HIGH MU DETECTOR & ECONOMY POWER PENTODE VALVES

**89/6**

Or 8/6 deposit and 12 monthly payments of 7/6.

**GREAT LISSEN CHART**

ASK YOUR DEALER OR POST THIS COUPON **FREE**



TO LISSEN LTD, Dept. P.W. 126, WORPLE ROAD, ISLEWORTH, MIDDLESEX.  
Please send me FREE copy of your 11- Skyscraper Chart.  
Name ..... Address .....

# LISSEN SKYSCRAPER 3 KIT



EDITOR:  
Vol. 1. No. 11. F. J. CAMM || Dec. 3rd, 1932.

Technical Staff:  
H. J. Barton Chapple, Wh.Sch., B.Sc. (Hons.), A.M.I.E.E.  
Frank Preston, F.R.A., W. J. Delaney, W. B. Richardson.

## ROUND *the* WORLD of WIRELESS

### Ridgeway Parade

B.B.C. listeners will be pleased to learn that the Ridgeway Parade, with Philip Ridgeway directing, will face the microphone on December 22nd in an hour's broadcast from the Regional stations; the same programme will be heard the next day through the National transmitters.

### Curfew for Loud-speakers in Oran (Algeria)

IN Oran (Algeria), the authorities have passed a law by which the inhabitants are forbidden to use their loud-speakers after 10.30 p.m. and before 6.0 a.m. from April 1st to September 30th. From October 1st until March 31st sets must be switched off at 10.0 p.m., unless the owner is using head-phones. During the hot weather period (June 1st to September 30th) no loud-speakers may be used between midday and 3.0 p.m., as this would interfere with the after-lunch "forty winks"!

### Gounod's "Faust" Broadcast

THE second and third acts of Gounod's *Faust* will be relayed from the Theatre Royal, Birmingham, on December 1st. The opera will be performed by the Carl Rosa Opera Company, with a number of well-known singers in the cast.

### Novel Use for the "Mike" in U.S.A.

ACCORDING to a United States daily paper, a Hollywood star has invented a wireless relay which may prove a boon to many mothers of young children. She has installed a microphone at the foot of her baby's cot. Should the child cry in her absence the sound, picked up by the mike and duly amplified, works a relay which in its turn operates a gramophone. A record of the mother's voice soothes the infant, and it is hoped sends it again to sleep, pending her return home. A tall story—but a good one.

### Algiers Announcements

NOTWITHSTANDING the fact that the broadcasts of Algiers (Algeria), and Rabat (Morocco), are destined for both the French and Arab population, and that for the latter special native concerts are transmitted, it is seldom that announcements are made in any but the French language. Algiers, in the call, is pronounced, *Al-jhay* and Rabat with the last letter eliminated. Neither of these stations possesses a distinctive interval signal, although at the Morocco station a metro-nome is used at times.

### New Bavarian High-Power Station

ON 532.9 metres (563 kc/s) tests are being made by a new 60-kilowatt station recently completed at Erdinger Moos, some twelve miles from the city of Munich (Bavaria). In common with other German stations built to the order of the *Reichsfunk*, the energy of the transmitter can be considerably increased at short notice.

### U.S.A. Standard Times

IN the United States there are three standard times in force, namely: Eastern, Central Mountain and Pacific time. The difference between each is one hour, Pacific Standard time (Coast of

the programmes. The station was opened on November 2nd, 1920, and since that date has not missed a single day of broadcasting.

### Weather Reports from Croydon Airport

AT every five-and-thirty minutes past each hour, weather reports are broadcast by the Croydon Airport officials on 900 metres for the benefit not only of aeroplanes in flight but also for the information of the Continental Aerodromes, such as St. Inglevert, Le Bourget, Ostend, Brussels, Amsterdam, etc. In their turn these aviation centres transmit half-hourly reports of atmospheric conditions in their individual localities. Listeners situated in districts between London and the Channel can frequently hear messages exchanged on 900 m. between the air liners and the land stations.

### Langenberg's Chimes

THE chimes heard through the Langenberg (German) transmitter on 473 metres are not relayed from the Cologne Cathedral, but are imitated in the studio. They consist of four notes, E, A, C sharp and B, repeated at short intervals as from a clock tower. The sounds are automatically produced by small hammers striking metal tubes.

### Morse Coil Signs

IN Morse transmissions the number of letters comprised in the call are a sure indication of the class of station sending out the signal. Three-letter call signs are allotted to fixed or land stations, four letters to ships, five letters to aircraft services, and combinations of a one letter or two letter nationality prefix followed by a numeral, and up to three letters are used by amateur or experimental transmitters.

### Telephony from Coastal Stations

IN the British Isles eight additional coastal stations have been equipped with wireless telephony apparatus to enable them to communicate with ships travelling in home waters.

The following stations are now in daily operation, and may be heard communicating with seaborne craft on wavelengths around 220 metres: Wick (GKR), Cullercoats (GCC), Humber (GKZ), North Foreland (GNF), Niton (GNT), Land's End (GLB), Fishguard (GRL), Seaforth (GLV), Port Patrick (GBK), Malin Head, Northern Ireland (GMH), and Valentia (I.F.S.) (GCK). Most of these stations are also available on request, for medical advice to ships in cases of emergency.

**NEXT WEEK!**  
**BIG CHRISTMAS**  
**NUMBER**  
*with*  
**SPECIAL**  
**16-page Phototone**  
**CHRISTMAS**  
**SUPPLEMENT**

California, etc.), being three hours behind that of New York on the Eastern Coast and, consequently, eight hours behind G.M.T. When it is 10.0 p.m. in Great Britain it is 5.0 p.m. in New York, Philadelphia, Boston, and so on, and 2.0 p.m. at San Francisco.

### KDKA's Record

KDKA, East Pittsburgh (Pa.), the pioneer broadcasting station of the United States, put over the ether 23,000 programmes in 1931, the studio officials during that period receiving 435,000 letters. To operate this station for twelve months five hundred thousand dollars were expended, of which one fifth was paid out in fees to artists taking part in

# ROUND *the* WORLD of WIRELESS (Continued)

## Viennese Listeners Census on Broadcast Programmes

WITH a view to ascertaining which kind of wireless programme is most appreciated, a Viennese journal submitted a questionnaire to its readers. Eighty questions were asked and 110,312 replies were received. It was found that in the capital alone 73 per cent. of the receivers used were of the multi-valve type and 83 per cent. in the provinces. As regards entertainments, 70 per cent. of the listeners declared themselves against chamber music, 66 per cent. voted for variety, 30 per cent. for more gramophone records and 57 per cent. for light popular music; whereas 25 per cent. asked for musical comedy, only 50 per cent. declared themselves willing to listen to operatic performances.

The result of the census demonstrated that little change could be made in the programmes if the bulk of listeners was to be satisfied.

## Early Morning Broadcasts from Continental Stations

MANY of the Continental stations start up in the early morning hours with a broadcast of "physical jerks." In lieu of this feature the Dutch studios give an hour's recital of gramophone records beginning as a rule at 7.40 a.m. In the same manner a similar broadcast is made to finish up the day's programme. If you tune in to Hilversum on 296.1 m. on almost any evening at 10.40 p.m., you will enjoy a light concert. At 11.40 p.m. the station closes down with the midnight time signal, as Dutch time is twenty minutes ahead of G.M.T.

## Frankfurt's Old Transmitter

THE old Frankfurt-am-Main transmitter, recently replaced in that city by a new 17 kilowatt, is being rapidly dismantled. It is to be re-erected at Treves in the Moselle Valley, and when rebuilt, towards the early spring of 1933, will broadcast the Frankfurt-am-Main programmes on a common wavelength with Cassel.

## Sottens Broadcasts for Adults Only

UNDER the title "When the Kiddies are in Bed," Radio-Suisse Romande (Sottens) carries out special relays from foreign cities destined for adults only. The first of these consisted of a running commentary on the night-life of Paris, and included visits to some of the popular resorts in Montmartre, with excerpts from performances given at night-clubs and cabarets.

## German Stations Recording on Wax

MANY of the German stations, and in particular Berlin, Breslau, Cologne and Stuttgart, make a speciality of recording on wax, for the use of their individual studios, any topical event in their district by which they can supplement their local news bulletins. The records made during the day are broadcast nightly during a feature entitled "Actualities." If of more than local interest, they are passed on to other German stations for transmission.

## INTERESTING and TOPICAL PARAGRAPHS

### BROADCASTING FROM CAR TO PLANE.



The photograph shows Sir Alan Cobham broadcasting from a van, as related in detail in column three.

gramophone records, featuring artists well known to B.B.C. listeners, are also given by Radio Normandie (Fécamp) on 225 metres nightly between 12.30 and 1.0 a.m. (Saturdays excepted).

## German Women Announcers to be Replaced

FOLLOWING a census organized by the Berlin studio, it would appear that German listeners do not favour the employment of women studio announcers, and where they have been engaged, it has been decided to replace them gradually by members of the male sex.

## Strike of Hungarian Opera Singers

A NUMBER of Hungarian opera singers have declared a strike, and refuse to take part in performances which are broadcast through the Budapest transmitter. The reason given is that their salaries were recently reduced to meet economic conditions, and that no extra payment is made when a microphone is installed at the Opera House.

## Future of Radio-Paris?

IN France, rumours are plentiful in respect to the future of Radio-Paris. On the one hand it is unofficially stated that the Postes and Telegraphes Administration has already started negotiations for the purchase of the new transmitter; on the other hand it is contended that the *Compagnie Française de Radiophonie*, the owners and operators of the station, propose to increase its power

to 120 kilowatts.

## Sir Alan Cobham's South African Tour

ON November 4th, Sir Alan Cobham left for South Africa upon an organized tour in the Union to popularize aviation, and with this object in view he will visit over seventy centres with a fleet of aeroplanes. Broadcasting from a public address van to an aeroplane in the air, and at the same time the transmission of messages to the public by the special public address apparatus, will play an important part in the aerial demonstrations. The wireless equipment has been selected with the greatest care, and among the well-known accessories that have passed exacting tests are Osram valves, with which the van has been equipped.

## Scheveningen-Haven Transmissions

ALTHOUGH Holland possesses only two broadcasting stations, namely Huizen and Hilversum, at various periods during the day Dutch transmissions may be heard on 1,071 metres. These emanate from Scheveningen-Haven near The Hague. The station was erected for the purpose of broadcasting commercial reports and market quotations. No wireless entertainments are transmitted, but on occasion this channel has been used for running commentaries on topical, political, or sporting events of interest to subscribers.

## Special Transmissions.

A WEEKLY broadcast of dance music is now made by Radio-Paris every Sunday between 5.30 and 6.30 p.m. G.M.T.; Special transmissions of up-to-date

# SOLVE THIS!

## Problem No. 11.

Jameson wanted to employ a push-pull stage in place of the output valve at present in his set. As he could not afford the two necessary transformers, he purchased only the output transformer, and retained the ordinary L.F. transformer for coupling the output stage. As he had two valves for the push-pull arrangement, he joined the two ends of the secondary winding of this transformer to the two grids of the output valves, and found the arrangement did not work. Why not?

Three books will be awarded for the first three correct solutions opened. Mark envelopes Problem No. 11 and send to the Editor, PRACTICAL WIRELESS, Geo. Newnes Ltd., 8-11, Southampton Street, Strand, London, W.C.2, to reach us not later than December 5th.

## SOLUTION TO PROBLEM No. 10.

The value of the coupling condenser which was chosen formed, with the primary of the transformer, a resonant circuit having a frequency which was well in the audible scale.

The following readers receive books in connection with Problem No. 9:—

Mr. C. Standley, 77, Westbourne Street, Handsworth, Birmingham; Mr. Francis Cooper, Dalmore, Craigie Avenue, Ayr, Scotland; Mr. B. C. Leadbitter, 51, Chevening Road, Brondesbury Park, N.W.6.



# THE ALL-IMPORTANT EARTH

Some Practical Advice on Methods of Fixing It.

By W. H. DELLER

### Earthing Plates

Fig. 1 shows a simple form of earthing plate. This consists of a piece of sheet metal, copper for preference, of fairly heavy substance: in any case not thinner than 18 gauge. This has a hole drilled in it about 5/32in. diameter, to pass the end of a length of bare copper stranded aerial wire made up of seven strands of copper wire

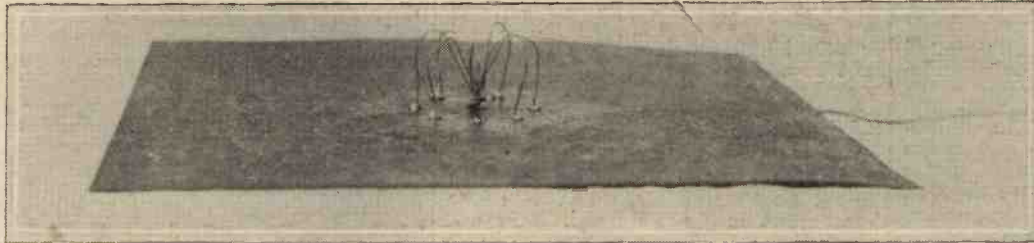

Fig. 1.—The simplest form of earthing plate.

NO matter how efficient an aerial may be, good results must not be expected if the earthing system is neglected. In fact, it is true that whereas a set may work well with an indifferent aerial and a good earth, a reversal of these conditions is a sure cause of trouble.

The question then arises as to what constitutes an efficient earth, the answer being that which offers the lowest electrical resistance. For practical purposes, as far as the amateur is concerned, a counterpoise earth reduces this resistance to a minimum. Such an earth consists of a series of wires arranged below the aerial and running within a few feet of the ground. These are insulated like the aerial wires and a lead taken from them direct to the set. Owing to the space that such an arrangement needs, it is not one that is likely to be employed by the average listener, who usually adopts one of the more widely-known methods of earthing. Now, no matter what method is adopted, everything that is possible must be done to keep the resistance low. The first point to be considered, then, is whether the earth lead is to be connected to a water pipe, or if an earthing plate in one of its various forms is to be employed. In the comparatively few cases where a mains water service is non-existent this question automatically answers itself.

in mind the fact that the resistance of the earthing system must be kept as low as possible, the length of the lead from the set to the point of fixing should be fairly short, and in cases where the set is situated at a

twisted together, and which is commonly known as 7/22. About 6in. of wire is passed through the hole and a knot tied in the wire. The strands of wire behind the knot are separated, and the end of each wire soldered, with a good blob of solder, more or less equally to different parts of the plate. It will be noticed in the photograph that the knot is on the same side as that to which the wires are attached. The object of this is that any subsequent strain on the wire after the plate is buried is taken by the knot bearing against the plate, not by the solder, as would otherwise be the case. This at first sight may seem an insignificant detail, but it is one that, more than likely, will prevent unearthing the plate at some future date for the purpose of resoldering the wire. When burying the plate in the ground dig a good deep hole, as it must be remembered that a certain amount of moisture is necessary in the ground to maintain a good contact. Do not be content with a depth of 12 or 18in., as at the first suggestion of

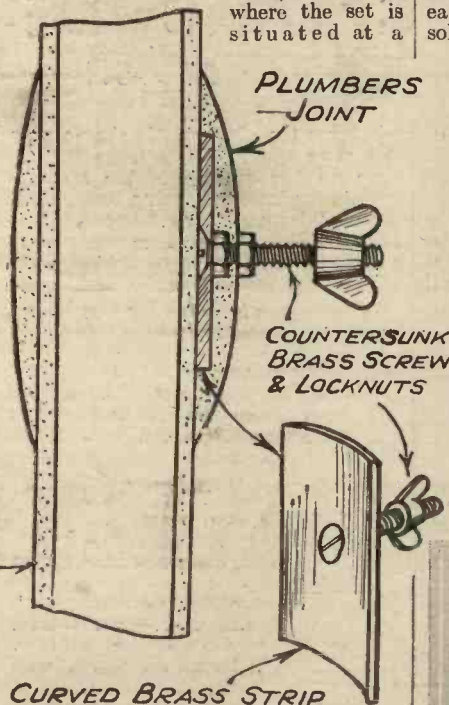

Fig. 3.—An ideal method of connecting to a lead pipe.



Fig. 2.—A fixing washer attached to an ordinary tap.

great distance from a convenient pipe it would be better to adopt an earthing plate.

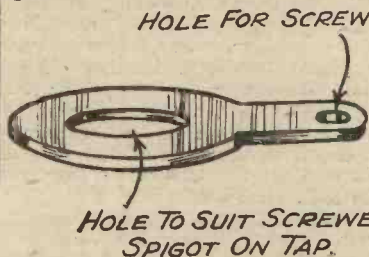

Fig. 4.—The washer required for the scheme shown in Fig. 2.

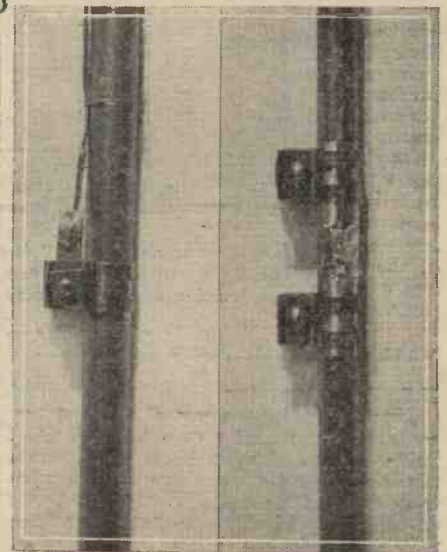

Fig. 5 and Fig. 6.—Two methods of attaching an earth lead to a water pipe.

But wherever available a water pipe makes a very convenient and reliable point of attachment for the earth lead. Bearing

a dry spell the earth will gradually become less efficient. It is also as well to bury the lead deep enough so that it will not be disturbed by gardening operations, and staple it to the wall of the house up to the point of entry.

Earth tubes are also obtainable and are made in several lengths. Bearing in mind the foregoing remarks, it is as well to purchase the longest. They are provided with a spike on one end, and are intended to be driven into the ground. Where the ground is likely to be stony, a hole should first be made with an iron bar. A terminal is provided at the top end for attaching the lead. Owing to the fact that this terminal and the wire will be exposed to the elements, corrosion at the point of contact will quickly take place. It is, therefore, advisable to solder the end of the lead to the top of the tube and take a turn of the wire under the terminal nut to relieve the joint from any strain.

Another form of earth is that known as "Filt," and consists of a copper receptacle containing a chemical substance which

spreads in the earth, and also has the power of attracting moisture.

**Using the Water Pipes**

Before connecting a lead to a water pipe make sure that the pipe selected runs to earth. Most pipes leading to a bathroom are fed from a cistern. So that the pipe to select is the incoming main or a cold-water tap downstairs, or a rising pipe feeding the cistern upstairs. A very good method of attachment to a lead pipe is that shown in Fig. 3, and consists of a piece of 16 SWG strip brass curved to conform to the radius of the pipe. A hole is drilled and countersunk in the centre to take a 1/4 in. or 5/16 in. Whitworth brass screw, and a couple of brass nuts hold the screw in position. The brass plate, screw head, and nuts are well tinned, and a plumber's joint makes it virtually a part of the pipe. The end of the wire is soldered to a large terminal tag, which is in turn secured under the w.g. nut. This will provide a durable connection at the cost of a few shillings' outlay for the plumber's time and material.

Fig. 5 shows an earthing clip which is obtainable in various sizes to suit different diameter pipes. The pipe should be brightened either by scraping or by polishing with very coarse emery cloth before fixing the clip. The wire is attached under the nut of the clip. An alternative method, and a better one, is that illustrated in Fig. 6, the wire in this case being soldered to a curved strip of well-tinned copper or brass, and is held in close contact with the pipe by means of two clips.

An easy means of providing a fixing lug to a cold-water tap is shown in Fig. 2. The top of the tap is removed as is necessary for renewing the seating washer. A brass lug is made to the shape shown in Fig. 4, the large hole being made to fit the threaded portion. A thin sheet-lead washer is cut to make a water-tight joint between the bottom face of the lug and the face of the tap body. It should be pointed out that as this lug must be in metallic contact with the tap, no other material, with the possible exception of a copper and asbestos washer, is suitable.

— FROM THE FLASHLAMP —

# SCREENING AND DE-COUPLING

By PHOTON

**T**HE subject of screening and de-coupling is too vast to be dealt with in a single "flash." Nevertheless, a little light is better than nothing. It is almost always that there are two complementary aspects of any problem summed up in the time-honoured statement that "action and reaction are equal and opposite." How often is it that the mind is concentrated on the "action," and the "reaction" is forgotten? Engineers

concentrated their attention on the uniformity of torque on the crankshaft of an engine for many years, before the complementary question of the equal and opposite torque on the engine frame was considered, variations of which are a common cause of vibration.

**H.F. Valve Screening**

Let us consider the case of a screen box containing the anode circuit of an H.F. valve, Fig. 1. Firstly, let it be supposed that the anode circuit (whatever it may be) as being fed from an H.T. battery without de-coupling. Then, before "earthing" the screen box let an alternating potential difference due to an incoming grid signal make its appearance on the anode of the valve and its associated parts. Then

whatever the electrostatic charge may be, the same will instantly make its appearance on the outside of the screen box. This is fundamental, being based on Faraday's "ice-pail" experiment. At the same instant a charge of the same magnitude but opposite sign will be delivered by the battery to "earth" and other negatively connected parts. So that there will be an alternating electrostatic field between the screen box and the earth connected parts and components of the set. Now let this be relieved by an "earth" connection from the screen box to some earthed part of the set. Then an H.F. circuit will be established from the H.T. + to the valve anode, thence by induction to the exterior of the screen box and thence by the earth wire to a connection to the H.T.— and so back through the battery. Without the earth wire to the screen box we had a widespread electrostatic field as dangerous to stability as though the screen box did not exist; with the earth wire we have a high-frequency circuit going round

through the battery equally capable of causing instability, unless surrounded with appropriate precautions. We now add a de-coupling condenser to the anode H.T. supply, Fig. 2 (say, of 2 m.f.d. capacity), which may have an A.C. impedance of 1 or 2 ohms, perhaps somewhat more. The object of this is that a large proportion of the A.C. H.T. component shall go by way of the condenser direct to the box, internally, where it can cause no reaction, instead of passing round the external circuit; this object is further promoted by the de-coupling resistance R on the

H.T. lead in. The condenser may now be regarded as in effect the H.T. battery or source of H.T. A.C. supply. Next to no A.C. passes round the external circuit, and the alternating electrostatic charge induced on the screen box is now neutralised internally by an equal and opposite charge from the condenser. But still something does go round the external circuit.

In a battery set the degree of de-coupling is limited by the drop in volts across the de-coupling resistance R. The H.T. valve must be supplied with sufficient anode volts to ensure the

valve functioning properly; in a screen-grid valve the anode E.M.F. should on no account be allowed to fall below 100 volts and a minimum of 110 volts is desirable. In a mains set or one fed by accumulators, say, 160 volts, this gives no difficulty. But when a dry battery of 120 volts is used the drop in the de-coupling resistance must not exceed 10 volts, and allowing 2 1/2 m.a. for the plate current, the resistance is limited to 4,000 ohms. Anything from 2,500 to 5,000 may be considered good practice, though it is quite common to find only a few hundred ohms used.

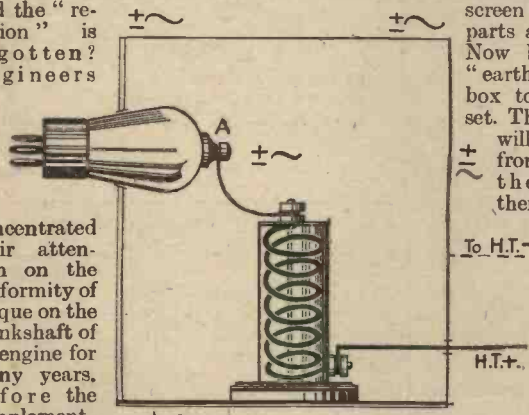

Fig. 1.—The anode circuit in a screened box, but the alternating H.T. component present outside as well as inside the box.

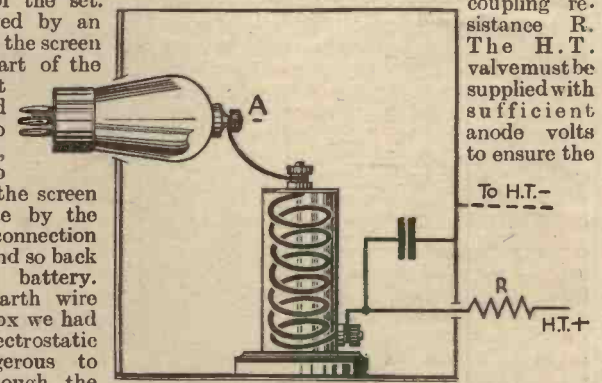

Fig. 2.—The inclusion of a de-coupling resistance outside, and a condenser inside the box, prevents the A.C. from leaving the box.

# Tracing and Curing Distortion

A Practical Article on the Cause of Distortion and Other Minor Faults Which Occur in a Battery Set.

By GILBERT E. TWINING

**O**CCASIONALLY, some component in a set will break down and cause trouble, for there is no definite period given over which any part of a set will last. The life of a component depends

stated by the makers on the outside of the battery case.

### Grid-bias Battery

The grid-bias battery deteriorates after a certain period, even when not in use. It is generally taken that its life is from six to nine months, after which it is policy to renew it. The amount of grid-bias given to the power valve will determine the amount of current flowing from the H.T. battery; therefore, if the G.B. fails, the valve will be under-biased and the H.T. is being used extravagantly, and the

signals, coupled with distortion, can be traced to a break in the windings of a transformer. A battery and headphones, connected across the transformer as shown in Fig. 2, will indicate by clicks in the headphones if the windings are O.K. The primary and secondary should be tested separately, and then the path between the two windings—which, of course, should not click in the 'phones—must be tested for shorts, or either of the windings might possibly be shorting to the core, and these should also be tested. It is not often, however, that the primary or secondary are found shorted to the core, but it has been known, and thus the inductance of the transformer is destroyed and, although there might be H.T. current flowing through to the anode of the valve, there would be no amplification and no signals, or, at least very weak and poor reproduction.

### Grid-leaks

Too high a value of grid-leak will cause distortion, and it is well worth while to experiment with them, changing from one to another. Even the grid condenser may be changed as well. The usual value of the condenser is .0003 microfarad, and that of the grid-leak 2 megohms. Better results may be obtained by reducing the grid condenser to .0001 microfarad and the grid-leak to 1 or even .5 megohm. Quality might be much improved and the high notes strengthened. If there is a break in the grid-leak circuit of the detector valve, the set will become unstable, and distort whenever a station is tuned in.

### Valves

The life of a battery valve is naturally governed by the number of hours of use, and it is generally assumed that 1,000 hours represents one year of service, after which the valve begins to deteriorate, commencing very slowly at first until distortion becomes perceptible to the human ear, gradually getting worse until reception becomes unbearable. The limit of a valve's life can therefore be taken as two years, after

which the running cost will appreciably increase. A valve of 20,000 ohms impedance over a period of, say, 1,000 hours, might take an anode current of 1½ milliamperes. But when the valve grows old its impedance drops, which means that the anode current increases, i.e., a bigger

(Continued on page 536.)

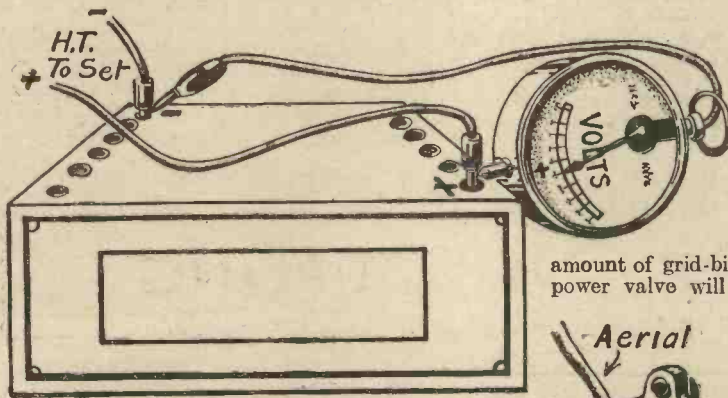

Fig. 1. Make periodic voltage tests.

upon how well it is manufactured in the first place, what its work is in the set, and how well it is treated by its owner. Here is given some of the components which, on partially or totally breaking down, will give distortion and generally bad all-round performance: high-tension, low-tension and grid-bias batteries, low-frequency chokes, low-frequency transformers, grid-leaks, and valves.

### High-tension Battery

When the H.T. battery is nearing the end of its life it becomes a common source of distortion, together with motor-boating and crackling. A careful voltage test should be made every so often with a voltmeter, and it should be connected in parallel, as in Fig. 1. It must be remembered that as soon as the H.T. becomes very low the biasing of the valve is increased; this can only lead to bad quality. A good test, if no voltmeter is available, is to reduce the grid-bias voltage; if this gives slightly louder and clearer signals, it proves that the H.T. current is too low and the battery needs renewing.

When fitting a new H.T. battery, however, it must be remembered that it is essential to increase the grid-bias value again to its original voltage, for when this is correct the H.T. battery is being used as economically as possible.

### Low-tension Battery

Always test the L.T. battery when there is any sign of distortion. It should never be allowed to drop below 1.8 volts. The test must be made with the voltmeter when the accumulator is on load, that is to say, when the set is working, for if it is tested away from the set, it will give an entirely wrong reading. A hydrometer will help to verify the voltmeter test, and will enable the density of the acid to be maintained at the correct specific gravity

amount of grid-bias given to the power valve will determine the amount of current flowing from the H.T. battery; therefore, if the G.B. fails, the valve will be under-biased and the H.T. is being used extravagantly, and the

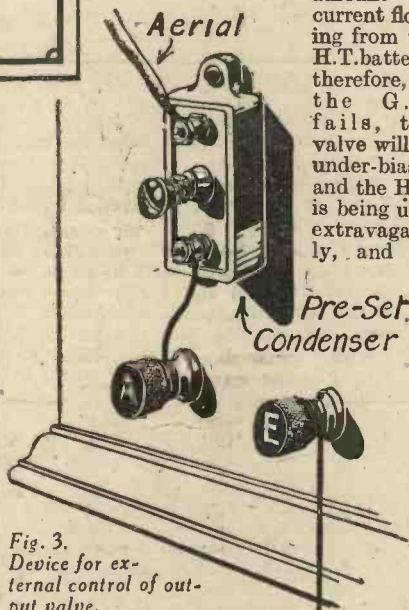

Fig. 3. Device for external control of output valve.

result is distortion.

### Low-frequency Chokes

An L.F. choke should be tested in the same way as a transformer for breakages in the windings, or, if other tests fail to show the cause of distortion, the choke should be temporarily short-circuited.

### Low-frequency Transformers

Some Head Phones

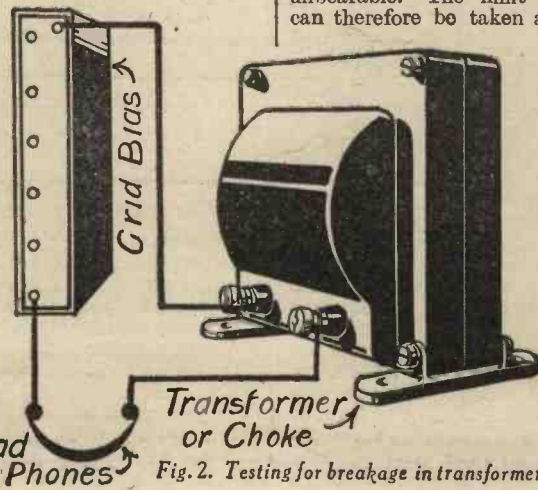

Fig. 2. Testing for breakage in transformer.

# SMOOTHING CONDENSERS

An Explanation of the Function of a Condenser with Especial Reference to Eliminator Circuits.

By G. H. WRAY, F.C.S.

A CONDENSER may be defined as a piece of apparatus which will accumulate a charge of electricity, and which consists of two conducting surfaces parallel to each other separated by a layer of insulation. In its most simple form it may be described as a plate of glass with a sheet of tinfoil gummed on each side. If one of the sheets is electrified with a positive charge and the other with a negative charge, the two charges will attract each other, or, in other words, they are held, or are bound by each other. The two sheets will acquire a much greater charge in this manner than either of them could possibly do if stuck to the glass alone and electrified. This quality of accumulating and retaining a large quantity of static charges, which two conductors possess when placed side by side and separated from each other by a non-conductor, is termed capacity.

The ordinary fixed type of condenser which we are discussing consists of a series of metal plates interleaved with an insulating medium known as the dielectric, which may be composed of waxed paper, or mica. In the case of the moving or variable condenser, the dielectric usually consists of air or oil. The capacity of a condenser depends upon the surface area and number of its metal plates or coatings, and upon the thickness and inductive capacity of the dielectric. All dielectrics are insulators, but equally good insulators are not necessarily equally good dielectrics. The degree of its ability to transmit the influence of an electrified body across it is called the inductive capacity of a dielectric. The name "condenser" is somewhat of an anomaly, for electrical condensers do not really condense, but store up the voltage applied to them. The capacity of a condenser is the measure of this ability to store up electrical energy, and the unit of capacity is termed the farad. A condenser is said to have a capacity of one farad when it requires a charge of one coulomb to raise the potential difference at its terminals to one volt. The coulomb is the unit of electrical quantity. Just as we say that water is flowing through a pipe at the rate of so

many gallons per minute, so we speak of electricity as flowing through a wire at so many coulombs per second. The farad, however, is much too large a unit for

a battery across it, as in Fig. 1, an accumulation of electrical energy will be acquired by the plates on one side of the condenser. When the battery is disconnected this accumulation is discharged through the coil, setting up a magnetic field and automatically charging the other side of the condenser. The reverse action then takes place, the charge flowing back through the coil in the opposite direction, and again

charging the opposite side of the condenser. This oscillating action repeats itself very rapidly many times, the charge in the meantime gradually dying away, due to the resistance of the circuit, the number of oscillations or reversals which occur depending, of course, upon this resistance.

## Capacity Illustrated by Water Analogy

Capacity in an eliminator circuit may be regarded as electrical resilience. A clearer conception of this can be obtained from a water analogy is shown in Fig. 2. The system consists of a pipe coupled to a spring-controlled plunger (b) and a valve. The pipe is connected to the water main, and the water pressure lifts the plunger.

If the valve is slightly opened, a steady stream of water flows through it, the tension exerted by the spring on the plunger maintaining an artificial head of water, thereby creating a tendency to negative any slight variations in pressure, which might be transmitted from the water main to the outflowing stream of water. If the valve is closed,

the plunger is lifted in proportion to the pressure in the circuit and the strength of the spring controlling the plunger, and when the valve is opened again, the stored-up energy passes back again into the system. This is analogous to the action of the condenser, which acts as a reservoir, or "artificial head" of electricity, and thereby tends to maintain a fluctuating current at a constant level.

(Continued on page 560.)

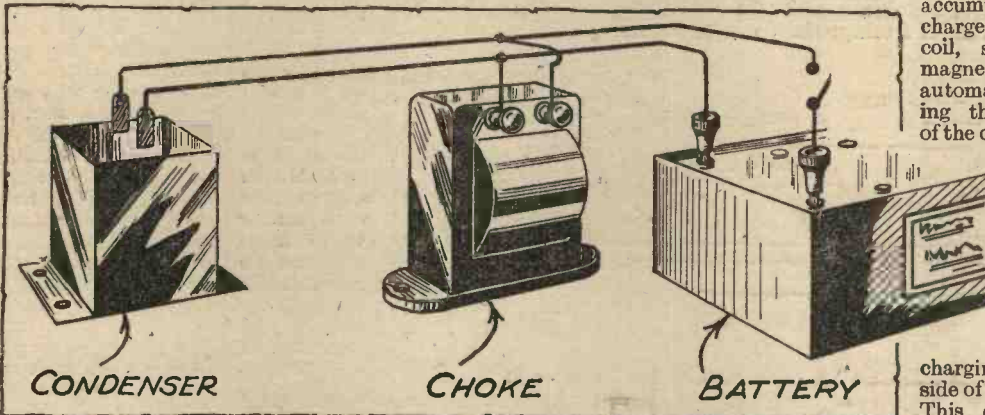

Fig. 1.—How a choke enables a condenser to discharge, and so even up ripple, etc.

practical use, and therefore as a practical unit the microfarad or one millionth of a farad has been adopted.

## The Function of Condensers in Eliminator Circuits

The action of the condensers incorporated in the circuit of an H.T. eliminator is, in conjunction with the smoothing choke, to absorb the ripple or pulsations present in the current whether D.C. or rectified A.C., and so provide a supply of "smooth"

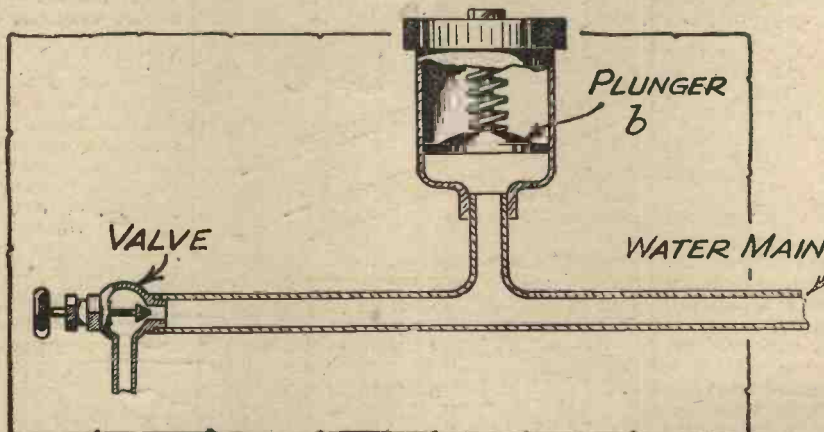

Fig. 2.—An interesting pictorial analogy of the function of a condenser.

direct current for use as high tension. When an electro-motive force is applied to a condenser it becomes charged; that is, it acquires a charge of electrical energy on one plate or set of plates connected together. If a wire is connected across the terminals of the condenser, it will discharge itself as a flow of current through the wire to the other plate or plates, and the condenser will return to its normal condition. If a condenser is connected in parallel with a choke coil, and charged by momentarily connecting

# DESIGNING *Your Own* MAINS TRANSFORMERS

An Article which Supplements that on the Same Subject given in No. 5 of "Practical Wireless."

By FRANK PRESTON, F.R.A.

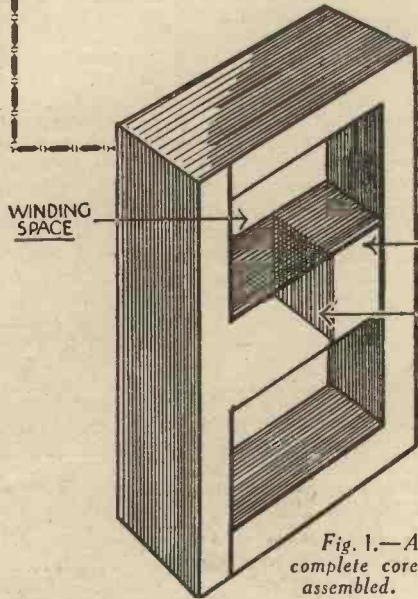

Fig. 1.—A complete core assembled.

doubled when the latter was reduced to  $\frac{1}{2}$  sq. in.

### Choosing the Core

From what has been said so far it is evident that before we can draw up any complete design the size of core must first be settled on. It will also be clear that it is the area of cross section of the winding limb (see Fig. 1) which is of first importance. This area is dependent upon the

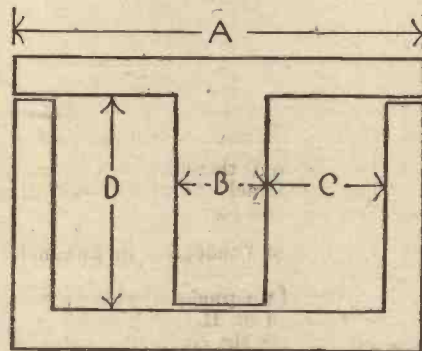

Fig. 2.—The principal dimensions of a transformer core.

TABLE No. 1.

Size of Stalloy Stampings.	Dimensions (Ins.)				Number of Stampings.	Watts (approx.)	Turns per volt.
	A.	B.	C.	D.			
5	3 1/8	5/8	1 1/4	1 1/4	6 doz.	25	15
4	3 9/16	15/16	1 5/8	2 5/16	6 doz.	50	8
4 A	3 9/16	15/16	1 5/8	1 1/8	6 doz.	40	8
30	3 9/16	15/16	1 5/8	1 1/8	6 doz.	40	8
30 A	3 9/16	15/16	1 5/8	13/16	6 doz.	35	8
28	5	1 1/4	2 1/4	3	6 doz.	100	6
29	6 1/2	2	2 1/2	4 1/4	6 doz.	250	4

SINCE the publication in PRACTICAL WIRELESS No. 5 of the article entitled, "Making a Mains Transformer," a large number of queries have been received by our Free Advice Bureau from readers who wished to make a transformer similar to that described, but modified to suit particular requirements. In some cases the transformer was required to operate from mains of different voltage and frequency to those assumed in the article, in others a higher or lower H.T. secondary voltage was necessary for a particular rectifier and again in other instances additional L.T. windings were needed for such purposes as heating the filament of a rectifying valve or operating pilot lights. We have replied in as much detail as possible to the querists, but in view of the interest that this subject has aroused, it has been considered advisable to outline the principles involved in transformer design in order that readers may work out for themselves such practical details as may be required in building an instrument in keeping with individual needs.

### Two Fundamentals

There are two fundamental things we must know before we can work out our design. These are (1) the frequency, in cycles per second, of the mains supply, and (2) the area of cross section of the core to be employed. It is from the latter points that we are able to compute the number of turns required for the various windings. With a Stalloy core of 1 sq. in. cross section, and when the mains frequency is 50 cycles per second, it is correct to allow 8 turns per volt. The latter number of t.p.v. varies in inverse proportion to the mains frequency, and the area of core cross section. For example, if the frequency was raised to 100 cycles whilst the core size remained constant, the number of t.p.v. could be halved, and conversely, if the frequency was reduced to 25 cycles the t.p.v. must be doubled. In the same way the t.p.v. would be halved when the core section was increased to 2 sq. in. and

amount of power, in watts, which is to be handled by the transformer. The power is determined by adding together the outputs of the various secondary windings and increasing the figure obtained by at least 10 per cent. to allow for losses which are bound to occur in the iron core and in the windings. In order to gain a full understanding of the latter statement let us take

TABLE No. 2.

Standard Wire Gauge.	Safe Current (amps.)	Turns per sq. inch.		Yards per Pound.	
		Enamelled.	D.C.C.	Enamelled.	D.C.C.
18	7	302	297	46.9	45.4
20	4	685	472	83.3	79.4
24	1.5	1,770	977	221	203
28	.7	3,760	1,630	488	422
30	.5	5,370	1,990	694	587
32	.4	6,890	2,550	915	755
34	.25	9,610	3,020	1,202	1,024
36	.18	13,500	4,110	1,840	1,477
38	.1	20,400	5,100	2,810	2,287
40	.07	32,500	—	4,576	—
42	.05	44,300	—	6,576	—

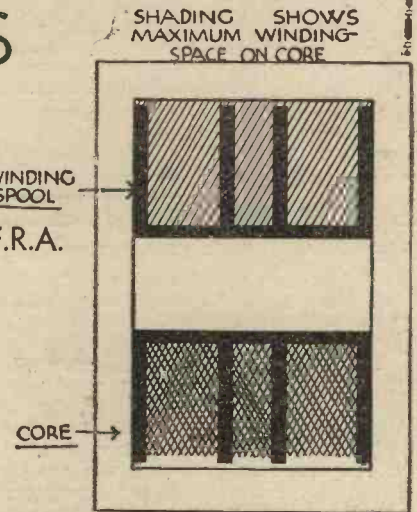

Fig. 3.—The difference between actual and theoretical winding spaces.

as example a transformer having three secondary windings, (1) giving an output of 250 volts at 100 milliamps, (2) an output of 4 volts, 4 amps and (3), of 6 volts, 1 amp. The power in watts is obtained by multiplying the voltage by the current (in amperes), so the number of watts delivered by winding (1) is 250 x 1/10, or 25 watts; by winding (2) 4 x 4, or 16 watts, and by (3), 6 x 1, or 6 watts. The total output is therefore 25 plus 16 plus 6, or 47 watts; adding 20 per cent. (to be on the safe side) brings the figure up to approximately 56 watts. To simplify the task of choosing

the correct size of core stampings a table is given (No. 1), and this shows the principal dimensions as well as the power handling capacities of cores built up from stampings of the more useful sizes. The table should be used in conjunction with the drawing (Fig. 2). In the case of each core size it will be noticed that the number of pairs of stampings is given as 6 dozen. This number makes a total core thickness of just about 1 1/16 in. (the stampings are .014 in. thick each), which is very convenient for most purposes.

### Numbers of Turns and Gauge of Wire

The table (left) also shows the correct number of turns per volt for a 50 cycle supply, so the only adjustments required will be in respect to alternative frequencies. In addition to knowing the required number of turns per volt we must also find out the gauge of wire most suitable for any given current output. This can easily be done by making reference to Table No. 2. If, for example, a H.T. secondary is required to give 50 milliamps (.05 amp.), 42's gauge wire will serve, but in the case of a low tension winding which is to supply 4 amps for heating the cathodes of four A.C. valves the wire must not be less than 20's gauge. As a matter of fact the currents shown are maximum ones and where ample winding space is available it is as well to

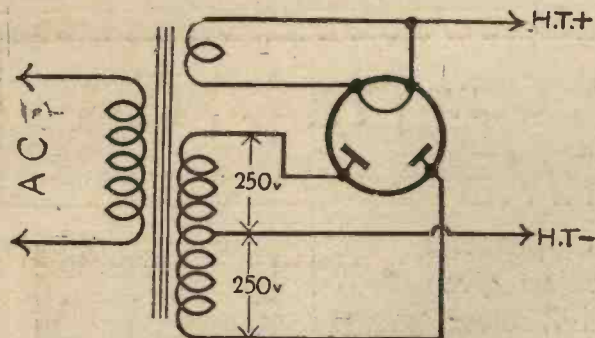

Fig. 5.—The circuit of a full-wave rectifier.

use wire one size larger than is actually necessary. It is also well to bear in mind that finer gauges than 38 are somewhat difficult to handle and should therefore be avoided unless one is cramped for space.

By using Table No. 2 no difficulty will be experienced in finding correct gauges of wire for the secondary windings, for which the currents are known, but the primary offers rather a different proposition. The primary has to deal with a wattage equal to the sum of all those of the other windings, plus that lost in the instrument. The actual power is that previously calculated in deciding on the core size, and so we can find the current by dividing the number of watts by the mains voltage. To revert to our previous example, where we found the power to be 56 watts; if the mains voltage were 230 the primary current would be 56/230, or about .25 amp. In regard to the most suitable covering; most constructors prefer to use enamelled wire when the gauge is finer (higher number, of course) than 24's, and double cotton-covered wire for the heavier gauges. Enamelled wire is cheaper, and the insulation is ample, provided the enamel is not cracked, but in the heavier gauges it cracks much more easily. Enamelled wire has the very great advantage that it can be accommodated in a much smaller space than other kinds. This is an important consideration when a large number of turns are required, but of little consequence where the turns are few.

**Alternative Core Sizes**

Although it has been stated that the size of core depends upon the power rating of the transformer it frequently happens that the power is a good deal less than the maximum for any size of stamping. In such cases the stampings will be chosen by the winding space they give. This point will more readily be understood by examining Table No. 1; it will be seen that stampings No. 4, 4A, 30 and 30A each have a winding limb of

similar size, but they have different areas of winding space.

The winding space required can be found by looking up the "turns per square inch" in Table No. 2. It must be remembered, of course, that a certain amount of the available winding space will be taken up by the winding spool and end cheeks, so due allowance must be made (see Fig. 3). In addition, the "turns per square inch" given in the table assumes perfect regularity in winding.

a complete loop round the core or it will absorb a good deal of power and considerably reduce the efficiency of the instrument. To prevent a short circuit of the gap by the core the plate should be insulated from the latter by means of a strip of insulating tape. The screen must, of course, be earth connected. When using this method of screening, separate spools must be used for each winding. If two or more windings are to be put in the same section of a spool, great care must be taken to provide adequate insulation between them by putting a few turns of empire tape or oiled silk on top of each winding and making sure that on later turns can slip past the insulation.

**Centre-tapped Windings**

A centre-tapped H.T. winding is required when rectification is carried out by a full wave valve connected as shown in the circuit of Fig. 5. In this case it should be remembered that the winding must be arranged to give the full rectifier voltage on each side of the tapping, or, in other words, the voltage between its two ends must be twice that required by the valve. The transformer would then be specified as having a 250-0-250 volt secondary.

**Testing the Transformer**

Before putting a transformer into use, it is desirable to give it a thorough test. Probably the best way of testing the windings for continuity is by means of a neon lamp, and the mains voltage. The lamp should be connected in series with one mains lead, as shown in Fig. 6, and the two wires (a) and (b) touched against the ends of the windings. If the lamp fails to light, a break in the winding is indicated. Next apply the same test between each winding and the core, and between pairs of windings. In the latter cases the lamp will not glow unless a short-circuit occurs at some point.

When a neon lamp is not available the transformer can be tested with a battery and a pair of phones, as explained for L.F. transformers in the article "Curing Common Receiver Faults," published on page 169 of PRACTICAL WIRELESS, No. 4.

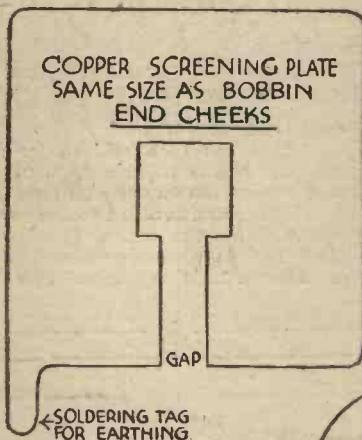

Fig. 4.—The screening plate for preventing hum.

For this reason it is usual to subtract 10 per cent. from the figures given, to allow for inevitable unevenness when winding by hand.

**Arrangement of Windings**

When both H.T. and L.T. windings are put on the same transformer it is a good plan to place the latter between the former and the primary windings. The L.T. windings, being connected to earth in the set, form a good screen, and are effective in reducing the amount of mains' hum reaching the H.T. supply. Another way of reducing hum is to insert a brass screening plate, like that shown in Fig. 4, between the various windings. The plate must not form

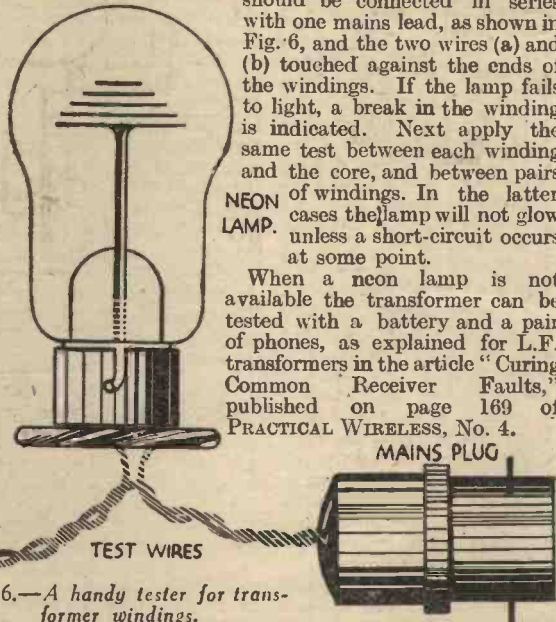

Fig. 6.—A handy tester for transformer windings.

**TRACING AND CURING DISTORTION.**

(Continued from page 533.)

drain is put on the H.T. battery, for it is a well-known fact that the lower the impedance of a detector valve, the higher its anode current.

**Overload Distortion**

Distortion caused by overloading means that the input to the set—and this refers to the signal strength of the station into which the set is tuned—is too strong. This is more likely to be caused by local station reception than by the weaker signals of foreigners. Overloading in the early stages of a set can produce very bad distortion, and to cure this it is as well to fit a volume

control before detection. If the valve is of the screen-grid variety, control of the screen-grid voltage is recommended, although when the volume is cut down very low, some distortion is noticeable. The best way, if it is possible, is to change over to the new variable- $\mu$  type of valve, the sensitivity of which is controlled by the variation of grid-bias; this will give a fine variation of volume, with the advantage that the quality will not deteriorate as the volume is cut down.

A simple type of control which may be fitted to the exterior of the set is shown in Fig. 3. This is a pre-set condenser, and is inserted in series with the aerial lead to the set. It should have a maximum value of .0003 microfarad. When it is unscrewed—that is to say, at its minimum

setting—it controls the voltage of the incoming signals to the set from the aerial.

Another form, which is very simple and easy to incorporate in a set, is a variable resistance or rheostat, connected in series with the negative side of the low-tension lead, feeding the screen-grid valve. This form of control cannot be used on A.C. mains sets, but only on battery-operated receivers. These points on distortion by no means cover the whole range of troubles, but only those most commonly met with.

**NEXT WEEK!**

**BIG CHRISTMAS NUMBER!**  
MAKE CERTAIN OF YOUR COPY!

# OBTAIN GREATER SELECTIVITY WITH A BAND-PASS ADAPTOR

This Article Tells You How to Make the Bandaptor at Little Cost.

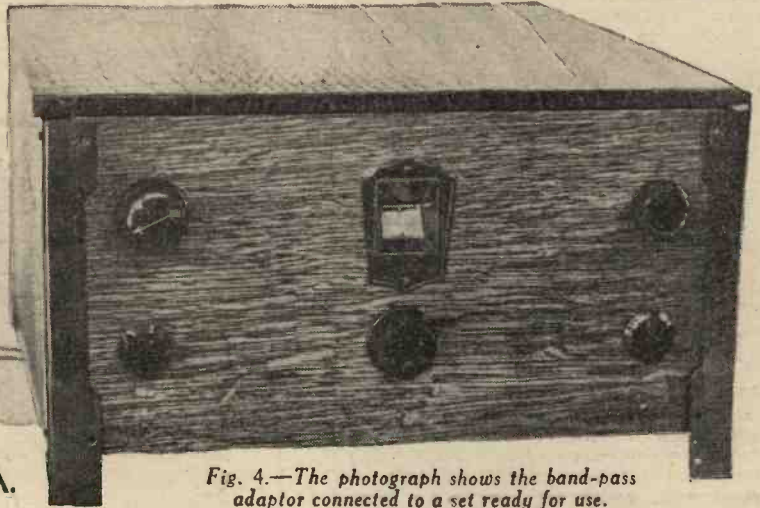
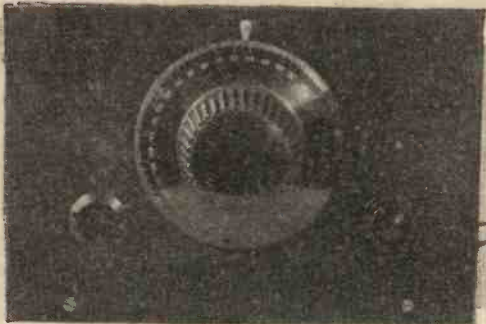

By FRANK PRESTON, F.R.A.

Fig. 4.—The photograph shows the band-pass adaptor connected to a set ready for use.

**S**ELECTIVITY is the order of the day, and unless our sets have it they are little more than useless for any other than purely "local" reception. How many powerful receivers are there that ought to be capable of bringing in fifty stations and yet whose useful range is restricted to the two nearest Regional transmitters—just because they are unselective? Most of the receivers built within the last year or so should be reasonably selective, but even some of these are not nearly so good as they ought to be. Without any fear of contradiction I can say that there is not a single receiver which is selective and which at the same time gives good quality of reproduction unless it is fitted with band-pass tuning or some form of tone correction device.

To make the last paragraph perfectly understandable I would say that although a single circuit can be made to tune as sharply as one may desire, that sharpness of tuning, or selectivity, is only obtained at the expense of quality. This is because the sharper tuning becomes, the more are the "side-bands" (which are in effect the musical frequencies impressed upon the carrier wave) "cut," or in other words, the more are the high notes attenuated or reduced in strength in proportion to the lower ones. The high note attenuation can be cured by fitting a tone control transformer, but even when this is done the selectivity is insufficient unless the tuner is of a specially designed pattern. And it is likely to become a somewhat costly undertaking to fit a new tuner as well as a new transformer.

### Band Pass or Tone Correction?

When designing a new set one has the option of using a specially sharp-tuning coil in conjunction with a tone-control trans-

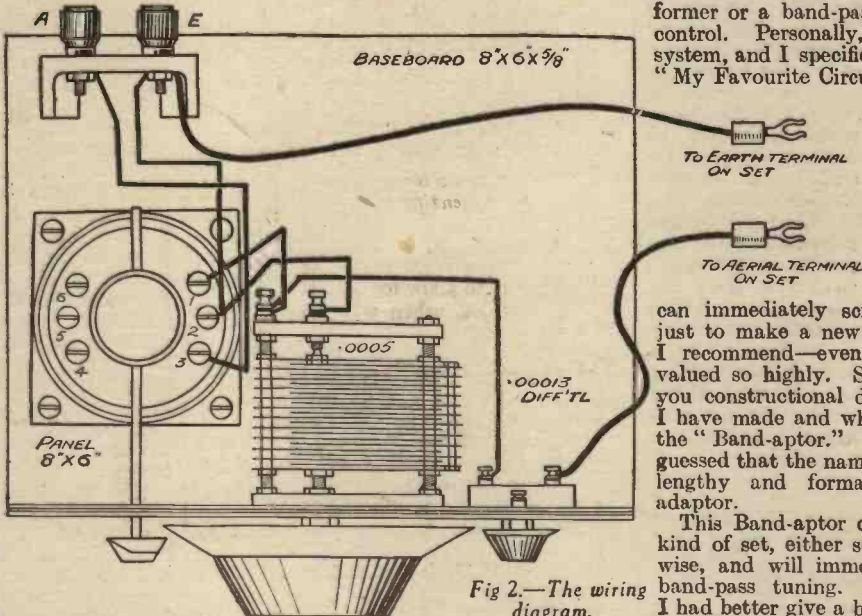

Fig 2.—The wiring diagram.

former or a band-pass tuner and no tone control. Personally, I prefer the former system, and I specified it when describing "My Favourite Circuit" in the very first issue of PRACTICAL WIRELESS.

### Economical

**Selectivity**  
But I know perfectly well that most of my readers are not so wealthy that they

can immediately scrap their present set just to make a new one of the kind that I recommend—even if my opinion were valued so highly. So I am going to give you constructional details of a little unit I have made and which I have christened the "Band-aptor." You will already have guessed that the name is short for the more lengthy and formal one of band-pass adaptor.

This Band-aptor can be used with any kind of set, either screened grid or otherwise, and will immediately convert it to band-pass tuning. Before going further I had better give a brief explanation of the band-pass system for the benefit of those who are not quite up to date with their

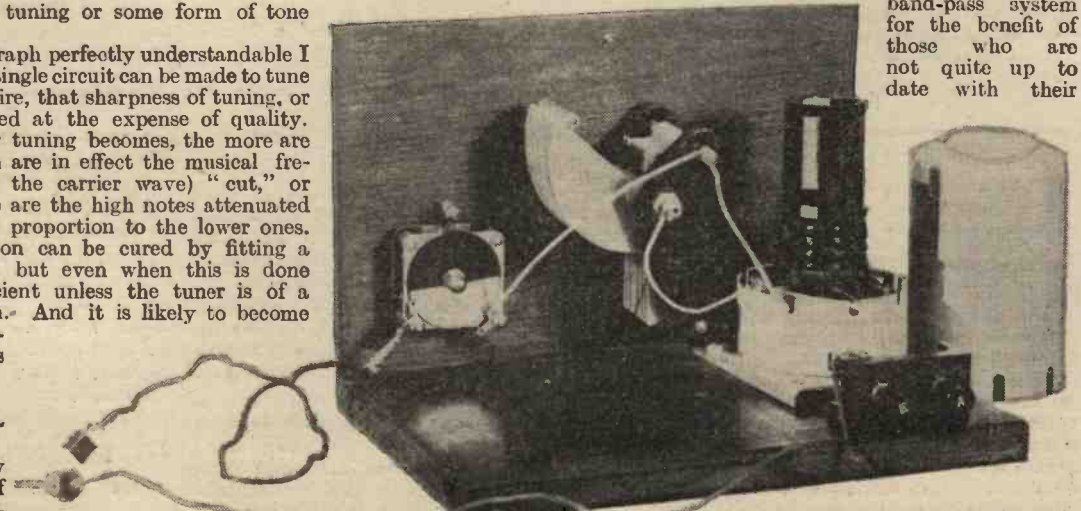

Fig. 3.—Showing the simple nature of the construction and wiring.

technical knowledge. It was explained above that as the selectivity of a single circuit tuner is increased its response to high notes is consequently reduced due to side-band "cutting." The band-pass tuner is so designed, however, that it gives equal response to a band of frequencies such as are represented by the side-bands, and therefore it responds equally well to all musical notes. In other words, it does not introduce distortion and thus no correction device need be used after it.

#### The Bandaptor is Cheap to Make

The Bandaptor will cost you about seventeen shillings in components if you have to buy them all, but you will probably have most of them on hand if you have been an experimenter for any length of time. To connect the Bandaptor to the set it is only necessary to transfer the aerial and earth leads from the latter to the unit and replace them with two leads attached to the Bandaptor.

#### The Circuit

A circuit diagram is given in Fig. 1 from which the more technically-minded readers will observe that band-pass coupling is on the "top-capacity" principle, a .00013 mfd. differential condenser being used for this purpose. The system of coupling is not very unusual, but I believe the method of providing an extremely small variable capacity is. By connecting to the two sets of fixed vanes only of the differential condenser we get the effect of two condensers wired in series. In consequence the maximum capacity is .0000325 microfarad and the minimum is only one or two micro-microfarads. This is just what we want. The screened coil specified has a .0001 mfd. fixed condenser built into it, so this is used as a series aerial condenser. Another similar type of coil may be used if desired, though, and in that case it will probably be necessary to employ an external .0001 mfd. condenser. As a matter of fact, it is advisable to employ the same kind of coil as that used in the aerial circuit of the set because the condenser tuning positions on both set and Bandaptor will then be similar. But this is not by any means essential, and if the coils are entirely different it will only mean that both condensers will be set to different numerical positions when tuned to any station.

#### Construction

The construction of the Bandaptor is child's play, as can be seen from the wiring plan of Fig. 2, and the photograph of the working parts in Fig. 3. First of all, make

the panel and baseboard; stain them and then drill a hole in the centre of the panel for the bush of the .0005 mfd. tuning condenser. Screw panel and baseboard together and lay the coil in position. With the switch rod scratch

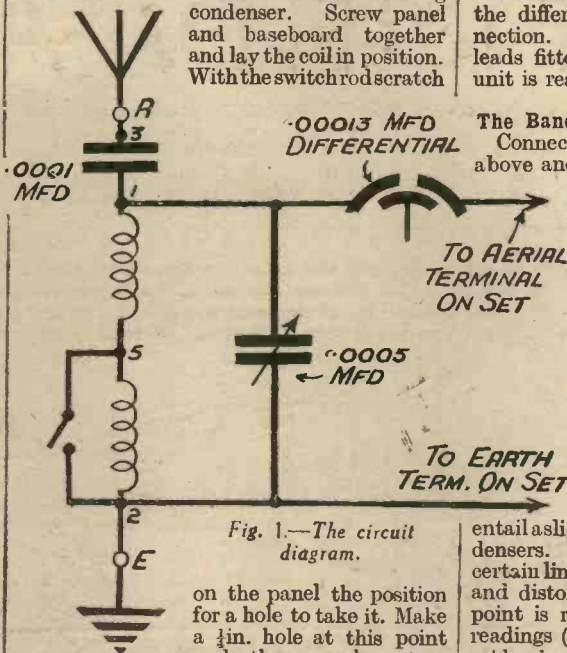

Fig. 1.—The circuit diagram.

on the panel the position for a hole to take it. Make a  $\frac{1}{4}$  in. hole at this point and then mark out a corresponding position towards the other end of the panel. By mounting the differential condenser in this latter position, a perfectly symmetrical panel lay-out will be obtained.

Should you wish to use condensers other than those specified, be careful that the moving vanes can be turned without fouling. At this stage attach the dial pointer; its correct position can be found after attaching the condenser dial. When all components are mounted connect up, with

#### LIST OF COMPONENTS FOR THE BAND-PASS ADAPTOR.

- 1 Plywood Panel, 8in. by 6in.
  - 1 Baseboard, 8in. by 6in. by  $\frac{1}{4}$ in.
  - 1 Terminal Mount (Belling-Lee).
  - 2 Terminals, marked "A" and "B" (Belling-Lee "Junior").
  - 2 Spade Terminals (Belling-Lee).
  - 1 Dual Range Tuner (Colvern type KGR).
  - 1 .0005 mfd. Variable Condenser (Lotus).
  - 1 Dial Pointer (Bulgin).
  - 1 .00013 mfd. Differential Condenser (Lotus).
- Short length "Glazite" and a foot of twin flex.

"Glazite" insulated wire, as shown in Fig. 2. It will be noticed that three terminals on the coil and the centre one on the differential condenser require no connection. Lastly attach the two flexible leads fitted with spade terminals and the unit is ready for use.

#### The Bandaptor in Use

Connect it to the receiver as explained above and set the differential condenser to maximum capacity (vanes half in mesh). Tune the receiver to the usual position of the local station and then rotate the tuning condenser on the unit until signal strength is brought up to maximum. Slightly re-tune the set if necessary and make a final adjustment to the Bandaptor condenser. With the differential condenser set to full capacity selectivity will not be much better than before, so after tuning in, the capacity must slowly be reduced by turning the knob (in either direction). This will probably

entail a slight readjustment to the tuning condensers. If the capacity is reduced below a certain limit the tuning will become too sharp and distortion will occur. So before this point is reached, make a note of the dial readings (even if a coil similar to that in the set has been used, one condenser will probably read a little higher than the other).

Now you can rotate both condensers together, keeping them in the same relative positions as they occupied when tuned to the station. In this way it should be possible to tune in station after station, all clear of interference. Remember that the Bandaptor is not of a form of wave-trap and must be tuned for every station. One setting of the differential condenser will generally cover the whole wave-range (either long or medium), but where two stations are very close together it might be necessary to effect a slight increase in selectivity by making a careful adjustment to it. It is a strong point in favour of "top-capacity" band-pass coupling that the exact degree of selectivity is under easy control.

If you are in any doubt as to whether the coupling condenser is properly adjusted you can tell in this way. Rotate (simultaneously) the tuning condensers on set and Bandaptor as slowly as possible. Signals should come in suddenly, remain for a degree or so and then suddenly disappear. If the tuning "spreads" over several degrees the coupling capacity is too great; if distortion occurs the capacity is too small.

## ROUND THE WORLD OF WIRELESS

(Continued from page 530.)

### Vatican's S.-W. Transmitter

**L**AUDATUR *Jesu Christus, Radio Citta Vaticana* is the opening call of HVJ, the Vatican (Rome) short-wave transmitter on 19.84 and 50.26 metres. This private station is used for the broadcast of official messages and Papal communications in various languages. On Holy Days a sacred service is relayed from the Sistine Chapel (Vatican). The transmissions may be identified by the ticking of a clock, which is regularly heard in the background of the broadcasts.

### Reception of Distant Transmissions

**D**URING the past fortnight atmospheric conditions have been peculiarly favourable for the reception of distant transmissions on the medium broadcast waveband, and in particular those emanating from North and South America are now well heard. Listeners report reception in the early morning hours (1.30-4.0 a.m., G.M.T.) of concerts from the following stations situated at Buenos Aires (Argentine Republic): LS8, Radio Sarmiento (243.9 m.); LS5, Estacion Rivadavia (270.3 m.); LR9, Radio Fenix (291.3 m.); LS6, Radio-Bernotti (222.2 m.); and especially from LR4, Radio Splendid (303 m.); LR3, Radio Nacional 9 (315.9 m.), and LR2, Radio Prieto (330 m.).

In most instances the stations are easily identified by their call, which is frequently given between items in the programme, and by the fact that announcements are made in both English and Spanish. The broadcasts from the United States mostly heard are those from WIOD, Miami Beach (Fla.), on 230.6 m.; WCAU, Philadelphia (Pa.), 256.3 m.; WPG, Atlantic City (N.J.), 270.1 m.; WBZ, Boston (Mass.), 302.8 m.; KDKA, East Pittsburgh (Pa.), 305.9 m.; WABC, New York (348.6 m.); WGY, Schenectady (N.J.), 379.5 m.; WJZ, Boundbrook (N.J.), 394.5 m.; and WEA, New York, 454.3 m. By law, the United States transmitters are compelled to give their call every fifteen minutes, and usually time their programmes accordingly.



# WHAT *is* TELEVISION? (PART 1)

An Introduction to the Newest of Sciences, in which the First Principles of Television are Explained by

H. J. BARTON CHAPPLE, Wh.Sch., B.Sc. (Hons.), A.C.G.I., D.I.C., A.M.I.E.E.

A LITTLE knowledge is not only likely to prove dangerous, but is definitely misleading, at least that is the conclusion I am forced to whenever a discussion arises with television as the main topic. There are so many mistaken ideas on the subject that its value is either underestimated or overestimated.

It is with the object of clarifying any ideas which readers of PRACTICAL WIRELESS may have on the subject that I am writing this series of articles, for I understand from the editor, that several requests have been made for information. I am sure that if I can succeed in putting forward the facts in their correct light, the amateur will be able to assess things at their proper face value. Furthermore, unless my judgment is badly at fault, I am sure he will come to the conclusion that this newest of sciences (that is, new from the practical home angle), offers ample scope for the display of his own ingenuity in building apparatus and making experiments.

While, however, we are accustomed to hearing at a distance, the idea of actually seeing the speaker at the same time is still strange. The one is in reality just as strange as the

fluctuating current is sent along wires to the receiver, where it passes round the coils of a magnet placed behind a metal diaphragm, and causes this plate to vibrate in unison with the diaphragm at the transmitting station, and so reproduce the speech (see Fig. 1). This sound is turned into electricity sent through space, or over wires as electric vibrations, and at the receiving station these electric vibrations are turned back into sound.

Another case, very analogous to this, occurs with the wireless broadcasting. The artist is positioned close to a sensitive microphone, and the sound-waves of the voice, as before, undergo conversion into equivalent current variations. After amplifica-

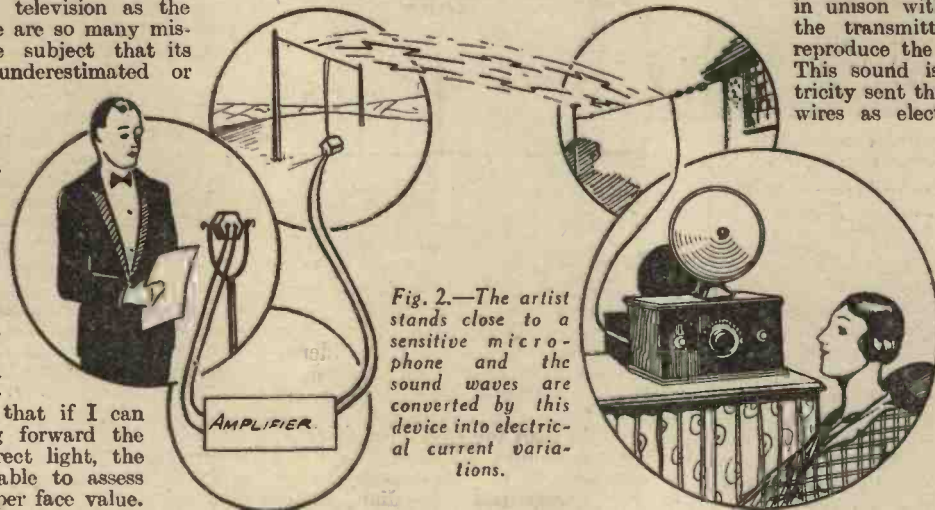

Fig. 2.—The artist stands close to a sensitive microphone and the sound waves are converted by this device into electrical current variations.

tion these variations modulate the high-frequency carrier-wave of a broadcasting station, and pass into space as electro magnetic waves (see the diagrammatic representation of Fig. 2). With the simple receiving aerial and wireless receiver installed in your own home it is possible to detect these signals and pass them through the set to the loud-speaker where they are heard. In this way the resultant effect is to produce an aural replica in the home of what is happening in the distant studio.

With television very much the same process is gone through. You stand in front of the transmitting apparatus and a rapidly-moving spot of light moves over you. The light reflected from your face affects a light-sensitive cell and causes it to send out a fluctuating electric current. This current is then transmitted to the receiving station by wires or by wireless, and at the receiving station is turned back into light again and re-creates an image of the face of the person seen (Fig. 3). In telephony no actual sound passes through the wires or the ether, only a fluctuating current of electricity; so also in television all that passes through the ether is a continuously altering electrical impulse, what the wireless man calls a "modulated carrier wave."

## "Seeing by Wireless"

First of all then, let us start by formulating a definition which will put matters on a firm footing. Very simply we can say that television is merely the process of being able to see through the medium of electrical methods of transmission, the reproduction of images of moving, living or stationary objects which are at some distance from the observer. In other words, it can be regarded as the reproduction of sight, for we can visually witness what is happening at a distance, just as if we were eye-witnesses on the spot.

Now our wireless receiver has made us become quite accustomed to hearing voices which come from hundreds of miles away. As, in this case, we are only using the ear, however, the position is similar to that of a blind man making the most of his unimpaired faculty, namely, hearing. The ultimate importance of television, therefore, cannot be overrated, for it is going to complete matters by adding sight to sound, as in the proper dual transmission of television you will be able to both see and hear in much the same way as you do now when a visit is paid to the local cinema.

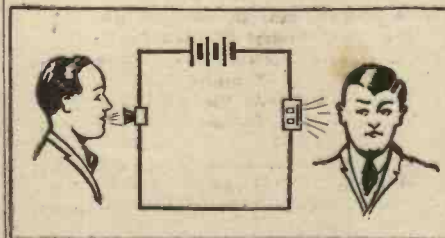

Fig. 1.—The conversion of speech.

phone your voice sets in vibration a small diaphragm or thin plate, and the vibrations of this plate alter the resistance of some granules of carbon. This sets up a fluctuating current, which alters exactly in unison with the vibrations of the voice. The

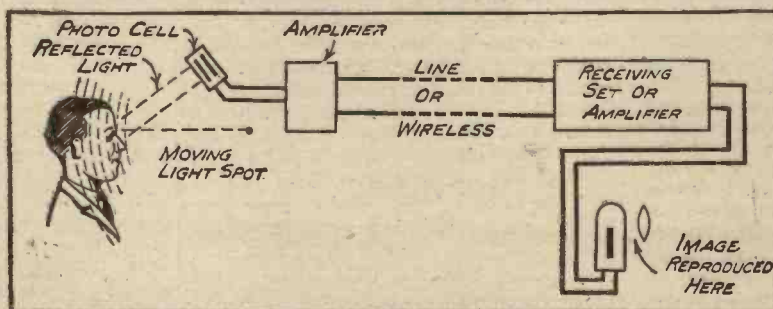
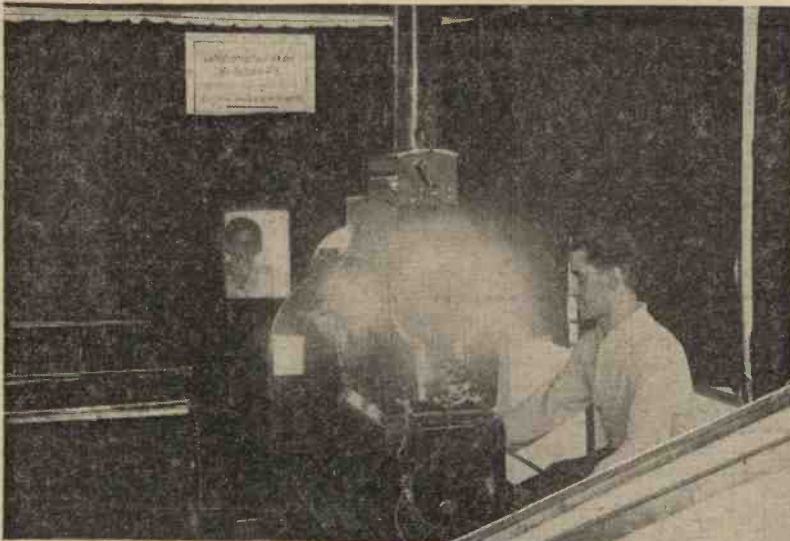

Fig. 3.—The individual to be televised stands before a special transmitting apparatus, while a rapidly-moving spot of light explores him.

## Television Broadcasts

What one may look upon as a marked revival of interest in television coincided with its inclusion by the B.B.C. in definite



A spot light television transmitter, built by Fernseh A. G. of Germany, in operation with the televised subject in position.

programme hours. This started in August of this year, and prior to that date experimental programmes emanated from the Baird Company's premises in Long Acre, from where they passed by land line to Savoy Hill and thence to Brookmans Park. Now, in a studio specially set aside for the purpose in Broadcasting House, is housed a mirror drum transmitter of the very latest design, built by the Baird Company. It is shown in one of the accompanying illustrations, and by suitable controls it is ingeniously contrived to be made suitable for close-up, semi-extended, and extended scenes. Undoubtedly the nature of the television programme now being transmitted by the B.B.C. on Monday, Tuesday, Wednesday, and Friday nights of each week from 11 p.m. to 11.30 p.m. constitute a considerable improvement on the earlier experimental transmission. The vision signals are broadcast from the London National station on a wavelength of 261 metres, while the accompanying sound may be heard from the Midland Regional station on a wavelength of 399 metres.

It should be pointed out quite early in this series that "seeing by wireless" is really only slightly more complicated than the everyday hearing by wireless, which we have now come to accept as part of our daily life. As a general standard it may be stated that anyone possessing a wireless receiver selective enough to receive a clear, audible signal of good strength and without distortion from the London National station can very easily add the necessary additional vision equipment for this purpose.

#### A Simple Experiment

As a small introduction, just try this little experiment for yourselves. When you have tuned in your local station to full volume, remove the loud-speaker and connect in its place a neon lamp—one of the ordinary spiral night-light pattern, or a letter type—which has had the ballast resistance removed from its cap. This resistance is removed quite simply by applying a small flame, say, from an ordinary gas burner, to the cap end of the lamp to melt the solder making contact to the pair of lead-in wires and also to soften the cement holding the bulb in the cap. Be very careful to prevent the flame playing on the

glass, or naturally this will crack and render the lamp useless. When warm, the cap can be pulled away gently if held with pliers. Then remove the resistance element and refix the brass cap in position with some suitable cement such as Seccotine, plaster of paris, etc., after first of all resoldering the leads to the cap contact points. Of course this lamp cannot then be again used in the ordinary house-lighting mains socket.

Since the lamp has the peculiar property of responding instantly to any varying currents which pass through it, the characteristic pinkish glow will alter in intensity as the current fluctuates. The signals from the output circuit of the wireless receiver will in consequence make the lamp flicker continuously, and you are then in a position to watch speech, song, or music, whichever is being broadcast at the moment, instead of hearing it. Most television systems make use of this property and at the moment the majority of them are essentially mechanical in principle. As, however, all the changes take place at a relatively high speed the eye does not dwell on the mechanics of the process, since the scanning apparatus brings about what may be termed a surface spread,

The subject of scanning is a rather complicated one, but this will be fully dealt with in my following article. When scanning the object it is necessary that the spot of light shall be caused to traverse the object which is being televised, and therefore some means of causing the light to move must be adopted. The method most commonly employed in the past was the scanning disc—a disc of metal furnished with a series of holes. In modern apparatus, however, the disc is superseded by a drum which is furnished with a number of mirrors. The advantages and disadvantages of these two methods will be discussed fully at a later date, but

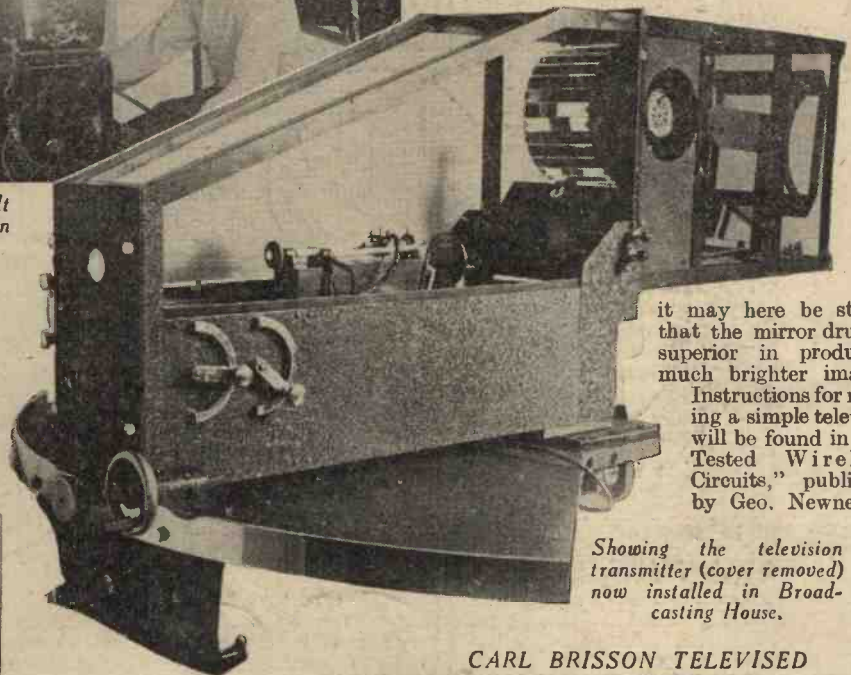

it may here be stated that the mirror drum is superior in producing much brighter images. Instructions for making a simple televisor will be found in "25 Tested Wireless Circuits," published by Geo. Newnes at

Showing the television transmitter (cover removed) now installed in Broadcasting House.

#### CARL BRISSON TELEVISED



A television broadcast was made recently by Mr. Carl Brisson, the actor, from Broadcasting House, Portland Place, W., to the Arena Theatre, Copenhagen, where he made his debut.

Left to right: Count Ahlefeldt-Laurvig, the Danish Ambassador; Mr. J. L. Baird, the inventor, and Mr. Carl Brisson, at the Broadcasting studio.

is., and obtainable for 1s. 2d. post free. Although a very simple piece of apparatus, this will be found to give exceedingly good results, and if constructed whilst this series of articles is being published, a better understanding of the various principles will be obtained.

# "Selectivity is of a high order..

Volume is enormous..  
Quality is excellent.."

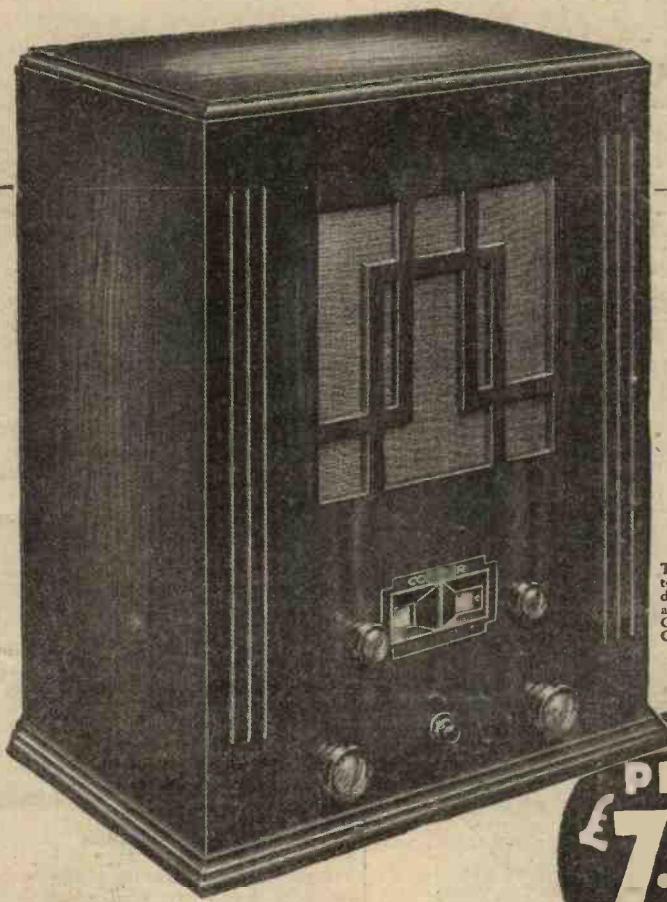

writes Yorkshire user:

YORKS.  
21/9/32.

Dear Sirs,  
..... I feel bound to send you a note of appreciation.

Selectivity is of a high order, comparing very well with a well-known set using a band-pass input filter and costing 20 gns.

Volume is enormous, I have to use the volume control for fear of making myself unpopular with neighbours!

Quality is excellent, as would be expected.

My aerial consists of 25 feet of wire round the picture rail. The number of stations I get would take much room to list.

I consider it to be far the best set for the price.

Yours truly,

Signed.....

The originals of the testimonials here reproduced may be inspected at our Head Office, Cossor House, Highbury Grove, London, N.5.

EVERY day we receive letters like the above. Other users write... "logged 49 stations"... "tone excellent—38 stations"... "not heard any Set so pure"... etc. etc.—overwhelming evidence of the efficiency of this remarkable Receiver. Equipped with Cossor Variable-Mu Valve—individually shielded coils—graded volume control—every up-to-date feature of design—the Cossor Melody Maker is undoubtedly to-day's greatest value in Screened Grid Radio. Send at once for full details—use the coupon.

PRICE  
£7.17.6

### BATTERY MODEL 335 with Self-Contained Loud Speaker

Kit of Parts includes Cossor 220 V.S.G. Variable-Mu Metallised Screened Grid, Cossor 210 H.L. Metallised Detector and Cossor 220P. Output Valves; Individually Shielded Coils, Cossor L.F. Transformer; All-Metal Chassis and all parts for assembling the Receiver as illustrated; handsomely finished cabinet 18 1/2 in. high, 13 1/2 in. wide, 10 1/2 in. deep and 10 in. Balanced-Armature Loud Speaker with rear adjustment. Provision is made for fitting Gramophone Pick-up Socket and Plug. Price **£7.17.6**

Hire Purchase Terms: 17/6 deposit and 5 monthly payments of 17/6

### ALL-ELECTRIC MODEL 337 with Self-Contained Loud Speaker

Kit of Parts includes Cossor M.V.S.G. Variable-Mu Metallised Screened Grid, Cossor 41M.H. Metallised Detector, Cossor 41M.P. Output and Cossor 442 B.U. Rectifier Valves; Individually-Shielded Coils; Cossor L.F. Transformer; All-Metal Chassis; Cossor Mains Transformer and all parts necessary for assembly. Handsomely finished cabinet 18 1/2 in. x 17 1/2 in. x 10 1/2 in. Balanced-Armature Loud Speaker with rear adjustment. Provision for fitting Gramophone Pick-up Plug and Jack. Price **£11.15.0**

All-Electric Models for A.C. Mains only, 220 to 250 volts (adjustable), 40-100 cycles. Hire Purchase Terms: 25/- deposit and 11 monthly payments of 22/-

### BATTERY MODEL 334

Kit of Parts, similar to Battery Model 335 except that no loud speaker is supplied. Handsomely finished cabinet 9 1/2 in. high, 13 1/2 in. wide, 10 1/2 in. deep. Price **£6.7.6**

Hire Purchase Terms: 14/- deposit and 9 monthly payments of 14/-

### ALL-ELECTRIC MODEL 336

Kit of Parts, similar to All-Electric Model 337 except that no loud speaker is supplied. Handsomely finished cabinet 10 1/2 in. high, 17 1/2 in. wide and 10 1/2 in. deep. Price **£9.15.0**

Hire Purchase Terms: 20/6 deposit and 10 monthly payments of 19/6

### ALL-ELECTRIC MODEL 338

Kit of Parts for building Cossor All-Electric Melody Maker Model 338 Chassis. Specification identical with Model 336 except that no cabinet is supplied. Kit includes escutcheon and template for drilling your own cabinet. Price **£8.15.0**

Hire Purchase Terms: 32/6 deposit and 8 monthly payments of 20/-

Prices do not apply in I.F.S.

A. C. COSSOR LTD., Highbury Grove, London, N.5. Depots at Birmingham, Bristol, Glasgow, Leeds, Liverpool, Manchester, Newcastle, Sheffield, Belfast and Dublin.

To A. C. COSSOR LTD., Melody Dept., Highbury Grove, London, N.5.

Please send me free of charge a full size Constructional Chart, which tells me how to build the Cossor \*Battery Melody Maker.

(\* Strike out type not required.)

Name.....

Address.....

PRAC. 3/12/32.

My usual Retailer is.....

Address.....

COUPON BRINGS YOU FULL-SIZE CONSTRUCTIONAL CHART

# Receivers and their Records

We shall be glad to advise readers regarding purchase of complete sets.

IF only by its moulded bakelite cabinet, the *Ekco Console* will attract your attention; it is of good design and pleasing to the eye. It houses a very efficient three-valve all mains receiver, and except for aerial and earth, is entirely self-contained. Even then it offers many advantages to the flat dweller, for it is equipped with both mains and internal aerial.

Many combinations to suit the locality in which the set is installed are thus available. If an external aerial is inconvenient, the mains may be used by the mere insertion of a plug (connected with the mains adaptor flex) into the aerial socket at the back of the receiver; in this case you may or may not use an earth, as you wish. If, however, your house happens to be within close proximity of electrical machinery, and thus makes reception liable to interference, the earth-lead alone as aerial (in the aerial socket) will provide satisfactory results. With the internal aerial the local programmes can be received at good volume even during daylight hours; at night in favourable circumstances it is possible to hear a few foreigners. From tests, it was found that with any of the combinations suggested in the book of instructions, broadcasts could be secured in varying degrees of strength, and in view of these many advantages the *Ekco Console*, for a three-valver, may be classed as one of the most adaptable models on the market.

Both the A.C. and D.C. types are adaptable to mains varying from 200-210 to 240-250 volts by the insertion of a knurled screw into the socket corresponding to the mains voltage, a change carried

## Ekco Three-valve Console Model M23.

(A.C. and D.C. Mains)

out easily by the merest novice. The D.C. model is provided with a special smoothing circuit incorporating an internal cathode potentiometer which can be adjusted to suit the mains, and by which any "hum" noticeable is considerably

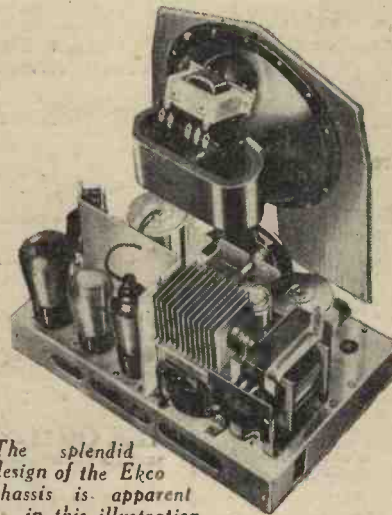

The splendid design of the Ekco chassis is apparent in this illustration.

decreased; in fact, in some cases almost entirely removed. This is a matter of altering two screw connections in the valve compartment of the receiver.

The three valves used are Mullard PML3 in the screened grid high frequency stage, PM4DX as detector coupled to a PM25 or Cossor 410PT as pentode output, feeding a built-in permanent magnet moving coil loud-speaker. The controls consist of a main tuning knob, centrally placed in the front of the set below the illuminated dial, and to this knob is affixed a concentric trimmer or compensator, both working the twin ganged condenser. Respectively on the left and right, are a combined selectivity and volume control, and reaction condenser; beneath these we find a lever operating the wave-change switch.

The range covered by the coils is respectively 200-550 on the medium waveband, and from 1,000 to 2,000 metres on the longer wavelengths. Some judicious use must be made of the volume and reaction con-

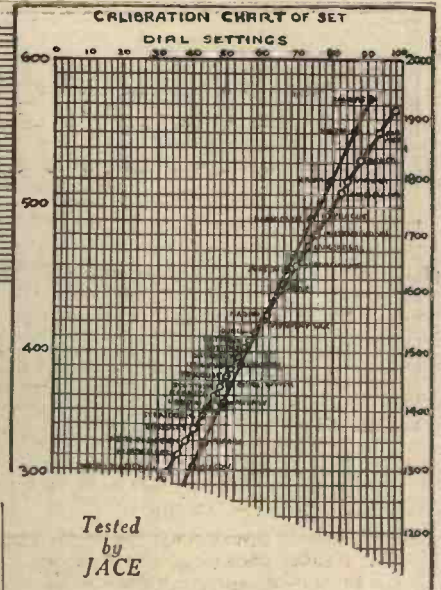

Tested by JACE

controls if good selectivity is to be attained, but experience will soon show that, providing they are well handled, there is no difficulty in securing separation of broadcasts on neighbouring wavelengths. Tested in the London area, within ten to twelve degrees of the actual condenser readings it was possible to cut out the Regional broadcast; slightly better results in this respect were achieved when dealing with London National. The combined selectivity and volume control acts directly on the aerial input, and thus plays an important part in tuning in transmissions flanked by powerful broadcasts.

The illuminated scale is directly calibrated in wavelengths, a principle which I consider of great assistance to the newcomer to wireless. It is merely a question of consulting one of the many lists of European transmitters published. Dial readings in degrees are somewhat puzzling to the tyro who is often apt to take them for either metres or kilocycles! Using an outdoor aerial of the average length (say, 60 metres), a number of broadcasts on the medium band from European cities were logged, and such stations as Brussels No. 1, Florence, Prague, Langenberg, Beromünster, Rome, Leipzig, Radio Toulouse, Strasbourg, etc., as well as B.B.C. stations, were heard at good volume, and without interference from their neighbours; on the long-wave range a number of transmissions were also clearly received; there was no "break-through" of the local B.B.C. broadcasts on the lower end of this coil, as is sometimes the case with less well-designed sets.

The *Ekco M23 Console* also makes provision for connecting a pick-up for the electrical reproduction of gramophone records through the built-in moving coil loud-speaker, but should one be used it must be fitted with an external volume control, such as a potentiometer. Reproduction of both music and speech were very pleasing; although bass response was good, there was no trace of resonance or boom, and if volume was not forced the spoken word was very natural.

Generally speaking, for a three-valver the *Ekco M23* possesses a number of good points and may be recommended as an all-round efficient receiver. The price for either model has been reduced to fifteen guineas.

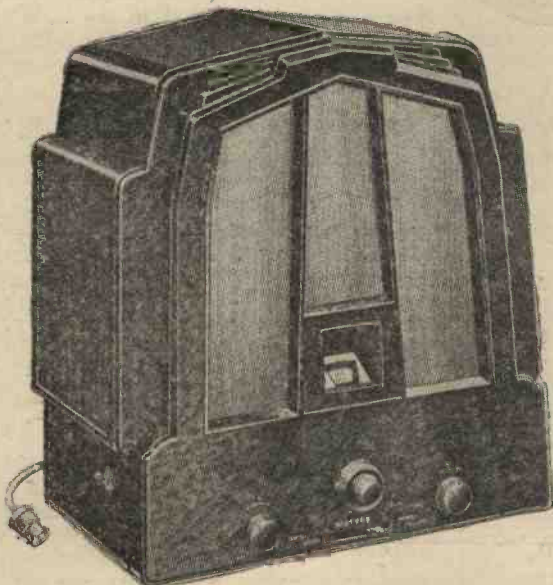

The Ekco three-valve Console model M23 (A.C. and D.C.).

# Christmas Gift Books

## GEORGE NEWNES, LTD.

### WIRELESS BOOKS

#### THE OUTLINE OF WIRELESS 8/6

By RALPH STRANGER (Omnibus size) *Post free 9/-*

A comprehensive work on wireless that everybody can understand. Specially written for the "man in the street," it covers the whole subject of wireless reception from A to Z. *Third Edition.*

#### THE MATHEMATICS OF WIRELESS 5/-

By RALPH STRANGER *Post free 5/3*

This book is essential for the wireless amateur who desires to gain a fuller knowledge of his subject. Written by one who has the gift of explaining abstruse subjects in a simple fashion. 256 pages, fully illustrated.

#### WIRELESS, THE MODERN MAGIC CARPET 3/6

By RALPH STRANGER. (*Fourth Edition.*) *Post free 3/9*

Wireless simply explained at the beginning and seriously treated at the end.

#### FINDING FOREIGN STATIONS 3/6

By R. W. HALLOWS. (Long Distance Wireless Secrets.) *Post free 3/9*

A book which will be eagerly welcomed by all wireless enthusiasts. It will solve their difficulties and enable them to obtain the best possible results of which their sets are capable.

#### WIRELESS STEP BY STEP 2/6

By "DICTRON." (*Ninth Edition.*) *Post free 2/9*

A book which shows the wireless enthusiast how to obtain the maximum enjoyment from his wireless set.

#### RADIO PLAYS 2/6

By L. DU GARDE PEACH. *Post free 2/9*

Millions of wireless listeners who have been thrilled by such plays as "The Path of Glory" and "The Mary Celeste" will now be able to read them in book form. Mr. du Garde Peach has written some of the most successful plays ever broadcast.

### The "WILLIAM" BOOKS 2/6 each

By Richmal Crompton *Post free 2/9*

For reading, anywhere, anytime, by anyone. Each volume contains a collection of "William's" side-splitting adventures.

WILLIAM—THE PIRATE  
WILLIAM'S CROWDED HOURS  
WILLIAM'S HAPPY DAYS  
WILLIAM THE BAD  
WILLIAM  
WILLIAM THE GOOD  
WILLIAM—THE OUTLAW  
WILLIAM—IN TROUBLE  
WILLIAM—THE CONQUEROR  
STILL WILLIAM  
WILLIAM—THE FOURTH  
WILLIAM AGAIN  
MORE WILLIAM  
JUST WILLIAM

### CHILDREN'S ANNUALS 1933

#### THE CIRCUS & FUN FAIR ANNUAL 2/6

NEW THIS YEAR. *Post free 2/9*

All old friends are here in picture and story—the Ring-master, the Trick-rider, the Clowns, and a host of funny men and animals.

#### PUNCH AND JUDY CHILDREN'S ANNUAL 2/6

*Post free 2/9*

Crammed from cover to cover with the adventures of Punch and Judy, to say nothing of the famous dog, Toby.

#### TIM, TOOTS and TEENY ANNUAL 2/6

*Post free 2/9*

Tim the cat, Toots the pig, and Teeny the duck are a queerly assorted trio and their comic antics are a joy.

#### HOBBIES' NEW ANNUAL 3/6

*Post free 3/9*

Contains practical descriptions of working models of every type. Fully illustrated and gives loose insets of parts for making workable models.

*Picture covers beautifully printed in colour. 128 pages. Profusely illustrated. Crown quarto. Quarter bound. Cloth spine.*

### "OMNIBUS BOOKS" 8/6 each

*Post free 9/3*

#### THE OUTLINE OF ART

Edited by Sir WILLIAM ORPEN, K.B.E., R.A., R.I.

A clear and concise view of the work of the great masters, and the essentials of present-day art; 300 reproductions.

#### THE OUTLINE OF LITERATURE

By JOHN DRINKWATER.

The history of literature from the earliest books to the work of the twentieth century writers. 80 pages of admirable reproductions.

#### THE OUTLINE OF NATURAL HISTORY

By Professor Sir J. ARTHUR THOMSON, M.A., LL.D.

This comprehensive work is a mine of information and a reliable guide to the study of Living Creatures. Fully illustrated.

### MISCELLANEOUS

#### THE BOOKLOVER'S DIARY

Leather 2/6; Cloth 1/-

*Post free 2d. extra.*

Published by *John o' London's Weekly*, in conjunction with Charles Letts & Co.

This delightful diary contains a wealth of information which will fascinate everyone whether interested in literature or not.

GEORGE NEWNES, LTD., 8-11, SOUTHAMPTON ST., STRAND, LONDON, W.C.2.

THE  
HALF-  
GUINEA  
PAGE

# Radio Wrinkles FROM READERS

**Space Economy**

THE following scheme of mounting valves inside coils often proves useful where it is desired to construct a compact set. Several of the unscreened types of all-wave coils are suitable, and those wound on a plain or ribbed former. The valve,

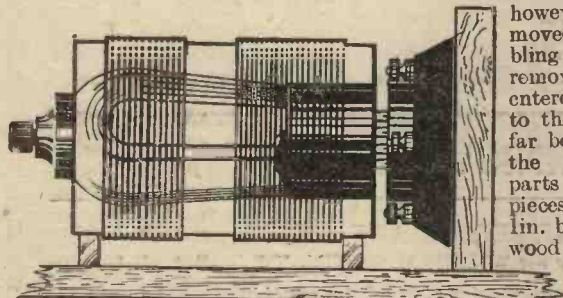
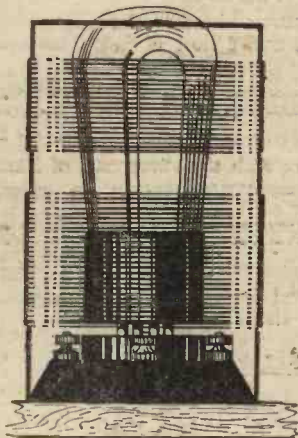

Two methods of mounting coils around valves to save space.

which may be either the detector or L.F., is mounted inside the coil, either vertically or horizontally. This arrangement can rarely be used with the H.F. valve owing to instability, but with low-stage gain circuits might be worth trying. Plug-in coils may be mounted in this way, but here the disadvantage lies in the fact that the valve must be removed before they can be changed.—R. T. WARD (Oxford).

**An Aerial Condenser Switch**

THE combination of an ordinary tumbler switch and a pre-set condenser, arranged in an aerial lead, as shown in the sketch, will be found a useful addition to a dual-range tuning coil which will not tune

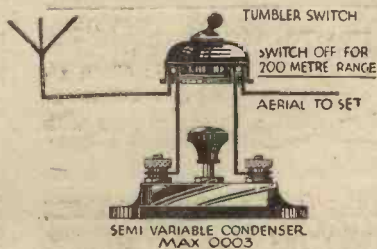

A useful aerial condenser switching arrangement.

**THAT DODGE OF YOURS!**

Every reader of "PRACTICAL WIRELESS" must have originated some little dodge which would interest other readers. Why not pass it on to us? For every item published on this page we will pay half a guinea. The latest batch is published below. Turn that idea of yours to account by sending it in to us, addressed to the Editor, "PRACTICAL WIRELESS," George Newnes, Ltd., 8-11, Southampton Street, Strand, W.C.2. Put your name and address on every item. Please note that every notion sent in must be original. Mark envelopes "Radio Wrinkle."

down to the region of 200 metres, or less. It enables stations such as Fécamp to be received, while by shorting the condenser, the receiver can be tuned to the longer wavelengths. The condenser and switch can conveniently be mounted on a piece of ebonite screwed to the side of the cabinet.—F. W. WHITE (Portsmouth).

**Method of Fixing a Set Inside a Cabinet**

THE usual method of fixing the actual set within a cabinet, is to screw the baseboard to the cabinet with ordinary wood-screws. There are occasions, however, when the set needs to be removed, and this entails a lot of fumbling with screws, and after several removals, the screws have to be entered in a different position owing to the wood becoming worn away. A far better method is that shown in the accompanying diagrams. The parts required for this method are two pieces of brass about 1/4 in. thick and 1 in. by 1/2 in. size; two small pieces of wood the same thickness as the baseboard; two 3/16 in. bolts, 1 1/2 in. long and two 3/16 in. nuts. The baseboard generally rests upon two stiffening pieces

running along the side of the cabinet. A hole 3/16 in. in diameter should be drilled in each of these, about half-way back, and 1/2 in. from the edge of baseboard. Then 1/2 in. from the top edge, slots should be cut out, with a small wood chisel, to take the 3/16 in. nuts, as shown at A and A<sup>2</sup>. The two small pieces of wood are fixed as shown at C. A 3/16 in. hole is drilled in each piece of brass, and these act as clamps to hold the set. The method of fixing is clearly seen in the diagram, the 3/16 in. bolts passing into the hole in the wood and then into the nuts. By using this method the set is firmly fixed, and is easily removed. To do this, it is only necessary to slack off the bolts and turn the brass strips through one-quarter of a turn, and the set will easily pull out of the cabinet.—H. HAINES (Newport, Mon.).

**Vibrating Reed Accumulator Charger**

A VERY effective accumulator charger may be made from an electric bell and a permanent magnet.

The magnet should be of a size sufficient to fit round the bell, as shown in the diagram. A magnet from a post office magneto is ideal, and can be picked up quite cheaply at a second-hand stall. The wiring of the bell is altered as shown, and the chief point is to see that the current flows through both the bobbins in the same direction. The positive wire of the charger is found by the usual acidulated water test, and is connected to the

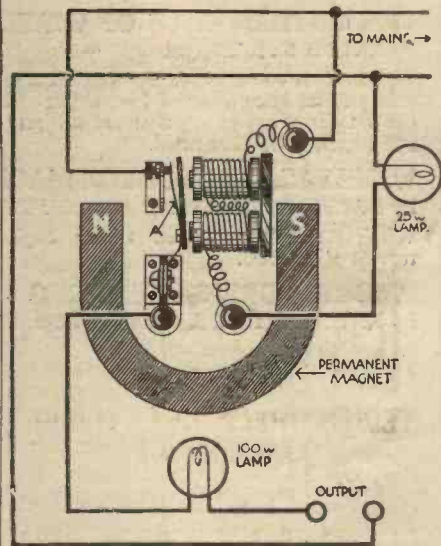

Showing construction and wiring connections of a vibrating reed accumulator charger.

positive of the accumulator. If excessive sparking occurs the spring marked A in the diagram must be removed or firmly fixed to the main armature. Although this type of charger is a little more difficult to construct it needs little or no attention when working. If carefully made, it will handle quite heavy currents without undue heating of the contacts.—J. HICKMOTT (West Kensington).

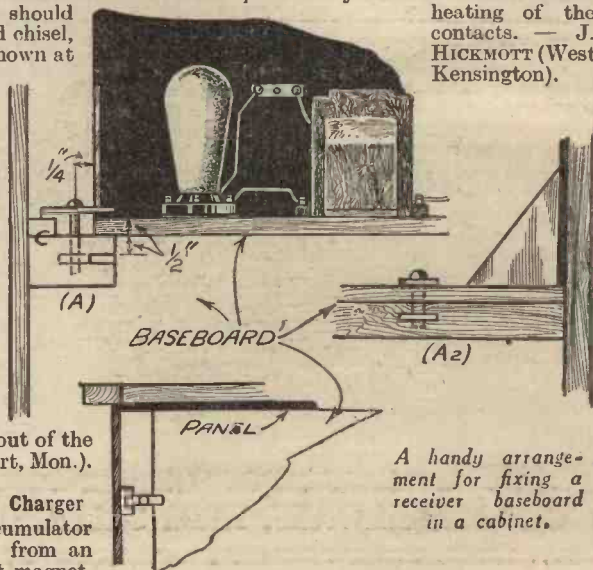

A handy arrangement for fixing a receiver baseboard in a cabinet.

**TELSEN**

# DIFFERENTIAL, REACTION & TUNING CONDENSERS

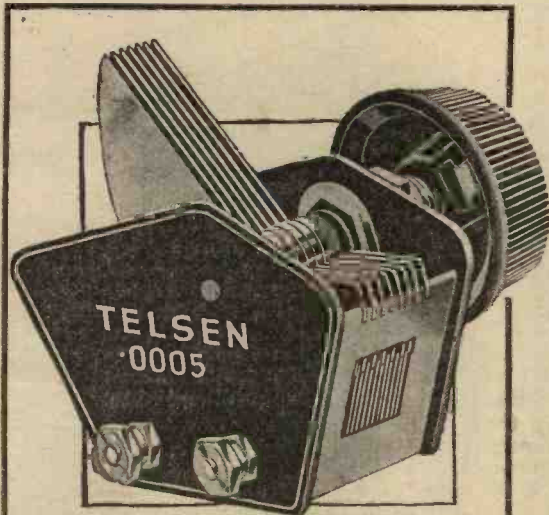

### TELSEN DIELECTRIC TUNING CONDENSERS

New design of great rigidity and exceptional compactness, ensuring the utmost efficiency in use even where space is very limited. The well-braced vanes are interleaved with a minimum of the finest solid dielectric, giving absolute accuracy of tuning. Supplied complete with knob.

In capacities '0005 and '0003 **2/6**

### TELSEN DIFFERENTIAL CONDENSERS

Improved type of exceptionally rigid construction. The rotor vanes are keyed to the spindle and fitted with definite stops. A strong nickel silver contact makes connection to the rotor, a positive connection being made to the stator vanes. Supplied complete with knob.

In capacities '0003, '00015 and '0001 **2/6**

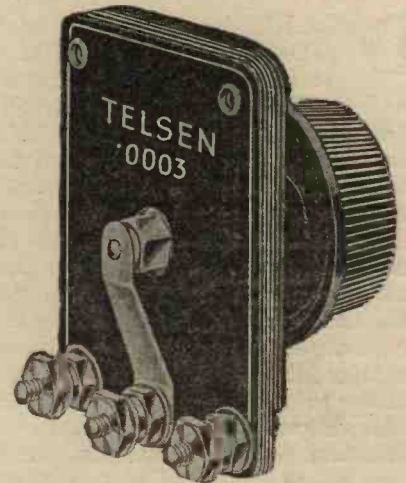

### TELSEN REACTION CONDENSERS

Built to the highest standards of efficiency, embodying every improvement and refinement indicated by the latest research. The vanes are interleaved with the finest solid dielectric, the construction throughout being of great rigidity and exceptional precision. Supplied complete with knob.

In capacities '0003, '00015 and '0001 **2/-**

In capacities '00075 and '0005 **2/6**

### TELSEN AERIAL SERIES CONDENSER

The ideal volume and selectivity control, solidly constructed, with very low minimum capacity. The externally keyed switch-arm when rotated to a maximum position, connects with a contact on the fixed vanes, thus short-circuiting the condenser for maximum volume. Supplied complete with knob.

Capacity '0003 **2/3**



# TELSEN

**RADIO COMPONENTS**

**TELSEN RADIO COMPONENTS ARE 100% BRITISH**

ANNOUNCEMENT OF THE TELSEN ELECTRIC CO., LTD., ASTON, BIRMINGHAM

# TELSEN SELF-SEALING CONDENSERS

**D**ESIGNED in accordance with the principles formulated as a result of the most recent research, and manufactured by the most modern plant in the world from the finest materials it is possible to obtain, these Telsen Self-Sealing Condensers represent a very definite advance on current condenser practice, embodying numerous features of outstanding importance. Only the highest quality foil paper and the finest linen tissue are employed in the exclusive method of manufacture, each individual plate being self-sealing and the case itself being finally triple-sealed with a newly-discovered bitumastic compound, for permanent efficiency. Every condenser is subjected to rigorous tests up to Post Office and Admiralty standards, the exclusive method of construction making them genuinely non-inductive. It is only because of this unique combination of research, plant, materials, method of manufacture and rigorous testing that Telsen Self-Sealing Condensers give such high insulation with such freedom from breakdown—such lasting efficiency under all conditions of use.

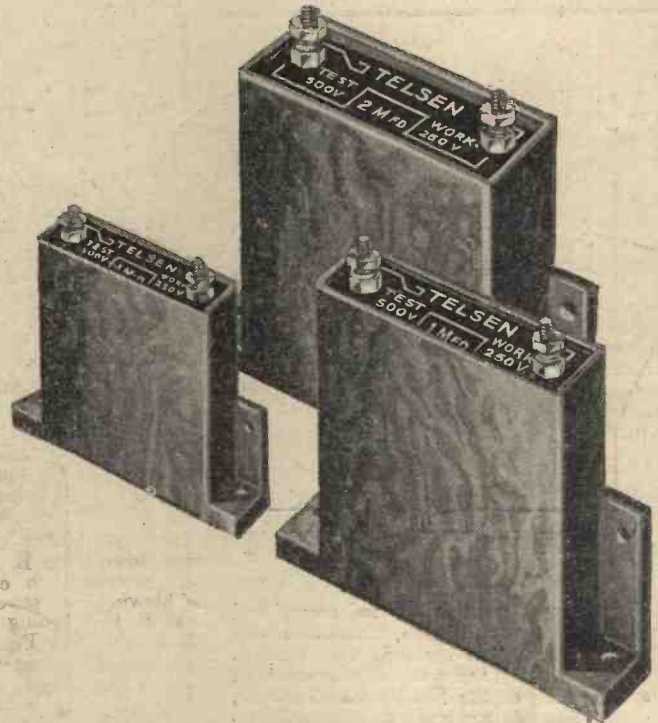

**TELSEN SELF-SEALING BAKELITE CONDENSERS**  
In attractive moulded bakelite cases, specially designed for 2-way fixing.

Cap.	500 Volt	1000 Volt
Mfd.	Test.	Test.
.01	1/6	2/6
.04	1/9	2/9
.1	1/9	2/9
.25	2/-	3/-
.5	2/3	3/3
1.	2/3	3/6
2.	3/-	5/-

**TELSEN SELF-SEALING BLOCK CONDENSERS**  
In metal cases with soldering tags.

Cap.	500 Volt	1000 Volt
Mfd.	Test.	Test.
4.	5/6	9/6
6.	8/-	14/6
8.	10/6	

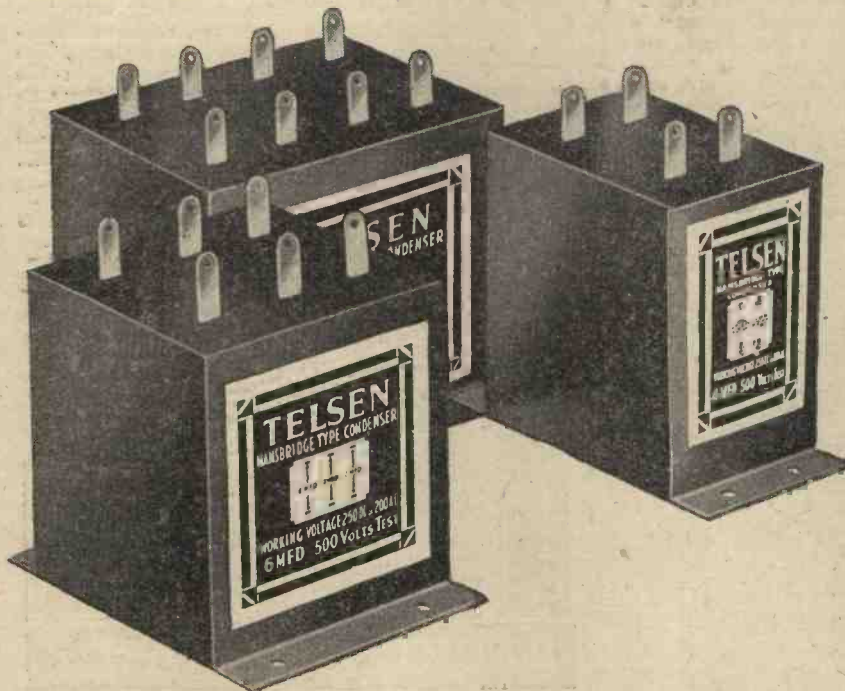

# TELSEN

**RADIO COMPONENTS**

**IT'S THE 'LASTING EFFICIENCY' THAT COUNTS**

ANNOUNCEMENT OF THE TELSEN ELECTRIC CO., LTD., ASTON, BIRMINGHAM



**Converting Dial to Slow Motion**

A CHEAP, easy and efficient way of converting old-type condenser dials to that of the slow motion type is as follows: Drill a hole in the ebonite panel below the dial, large enough to take the screw of an ordinary terminal. Fake terminal and fix top with solder so that it will not unscrew, and put around it one or two thick rubber bands. Place terminal through hole in panel, as shown in sketch, and secure at back with two nuts, so that it will freely revolve. The hole must be drilled so that if you fix your dial a little way out from panel, the rubber bands around the terminal will now press fairly hard against the bottom of the dial. Upon revolving the terminal the dial will revolve very slowly, the actual ratio depending upon the size of the terminal and the dial.—G. S. VICKERY (Maida Vale).

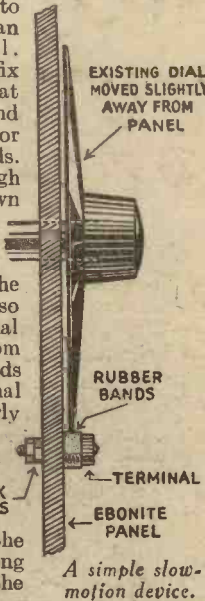

**Metallising Valves**

HERE is a method of metallising valves at home cheaply and simply, and if proper care is taken the effect is pleasing and the valve is efficiently screened.

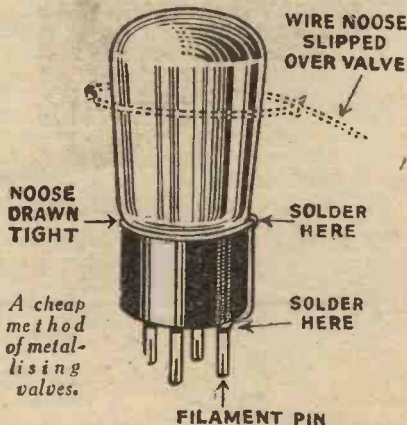

Obtain a bottle of aluminium paint, or other metal paint, obtainable at any paintshop or ironmongers for about 1s. (This will be enough to do all the valves in the set if needed). Then take a piece of bare copper wire, about 18 S.W.G., make a noose in the wire, and draw it tight round the base of the valve, the knot coming above the leg of the valve, which will be connected to filament negative. While holding the loose wire tight on the base of the valve, solder the knot in the wire, using as little solder as possible, then wind the other piece of wire round the pin of the valve connected to filament negative as near to the base of the valve as possible, and just apply a touch of solder. Next apply a coat of the paint to the glass bulb of the valve, being careful to cover the wire noose round the base of the valve but not to let any run down the base of the valve on to the other pins. When dry

apply another coat of paint, and the valve is ready for use.—G. E. HUMBERSTONE (Sheffield).

**Accumulator Tapping Apparatus**

IN the article, "Acid Drops," in PRACTICAL WIRELESS for October 1st, 1932, it is stated that accumulators are often returned from charging-stations not in a dry condition, a state of affairs sometimes caused through careless topping-up. It is a good plan to top-up cells before they go to be re-charged, and here is described an efficient filling apparatus only costing a few pence which, if used as described, enables the job of topping-up to be done expeditiously and not a drop of water (or acid) is spilled. The components are: one milk bottle, 20in. of 3/16in. glass tube, 14in. of 1/4in. rubber tube and a bung, made either of cork or rubber. Fit up as shown in Fig. 1. To bend the glass tube, heat up in a gas flame until pliable, bend, and hold in position until cool. To taper outlet tube, heat a 6in. length of tube in centre, draw out, then when cool, nick with file and snap off. You then have two outlet tubes, one being a spare. The most important part is the manner in which the bottle is used. To top-up cells, fill bottle with distilled water, replace bung (see that outlet pipe is not resting on bottom of bottle), place spout into cell, and start flow by blowing down tube B. It is not necessary to continue blowing, as gravity will keep flow going if bottle is held as in Fig. 2. When the desired height of electrolyte is reached, stop flow by pinching rubber tube at A, Fig. 2, and, still holding bottle horizontal, transfer to next cell, and so on. To discharge outlet pipe after filling all cells, hold bottle as in Fig. 3—then release thumb and finger from rubber pipe A, water will then run back into bottle.—E. R. SELLARS (Newark).

**A Neat Battery Container**

A NEAT and convenient method of housing the various batteries of a receiving set is shown in the accompanying sketch. Place the high-tension battery or mains unit by the side of the accumulator, and the grid-bias battery at the front.

Measure round the "ensemble," and make a wooden box to contain the three units. When the box is made, place the batteries inside, arranged as before, and screw to the top corner of the box a small terminal panel containing five terminals, or any lesser number to suit the particular radio receiver, and connect the underside shanks by flexible wires to the various points on the H.T., L.T. and G.B. batteries. Next procure a yard or so of 5-way cable and fasten the inner wires to the five terminals. Pass the cable through a hole in the side of the box, and connect the other ends of the five wires to a 5-prong battery plug (one could easily be made from a 5-pin valve base, or could be bought quite cheaply). This is then ready to supply power to the

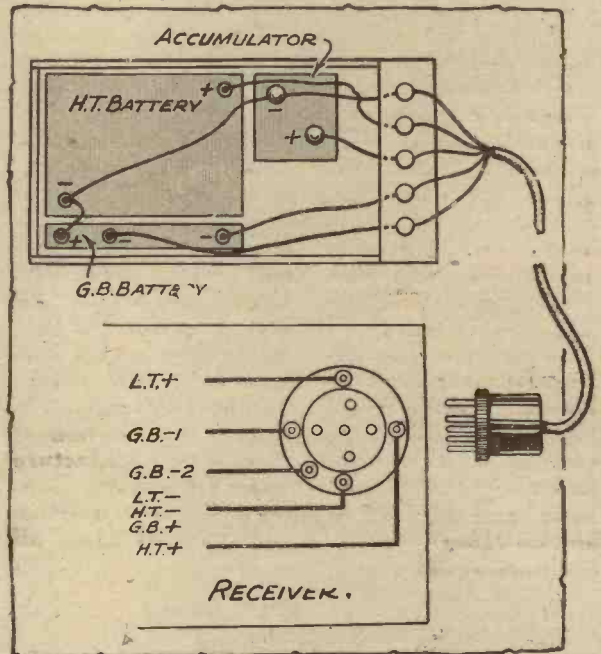

A neat container for housing an accumulator and dry batteries.

set and is plugged into a pentode valve-holder, which is screwed to the receiver chassis. The valve-holder terminals are permanently connected to the points that require the potentials. This method entirely eliminates half a dozen or so of untidy, straggling wires from the set to the batteries, and also prevents plugs being accidentally dragged out of the grid-bias battery and ruining valve emission. It also saves the accumulator from being knocked over and ruining carpets with the spilt acid.—E. D. WILLIAMS (Salford).

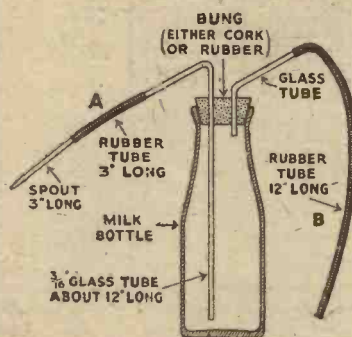

Fig. 1.

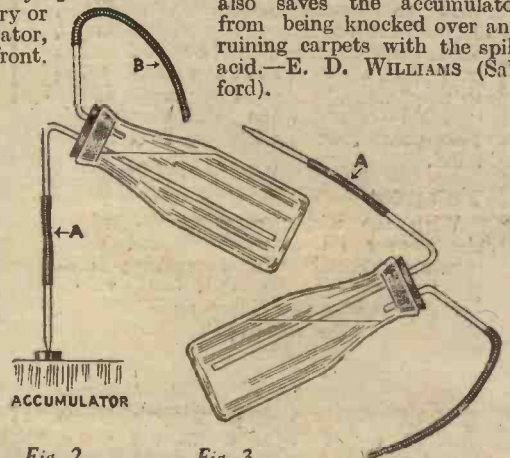

Fig. 2.

Fig. 3.

An efficient accumulator tapping apparatus

# OUR SHORT-WAVE SECTION

# CONSTRUCTING AND OPERATING THE EMPIRE SHORT-WAVE RECEIVER

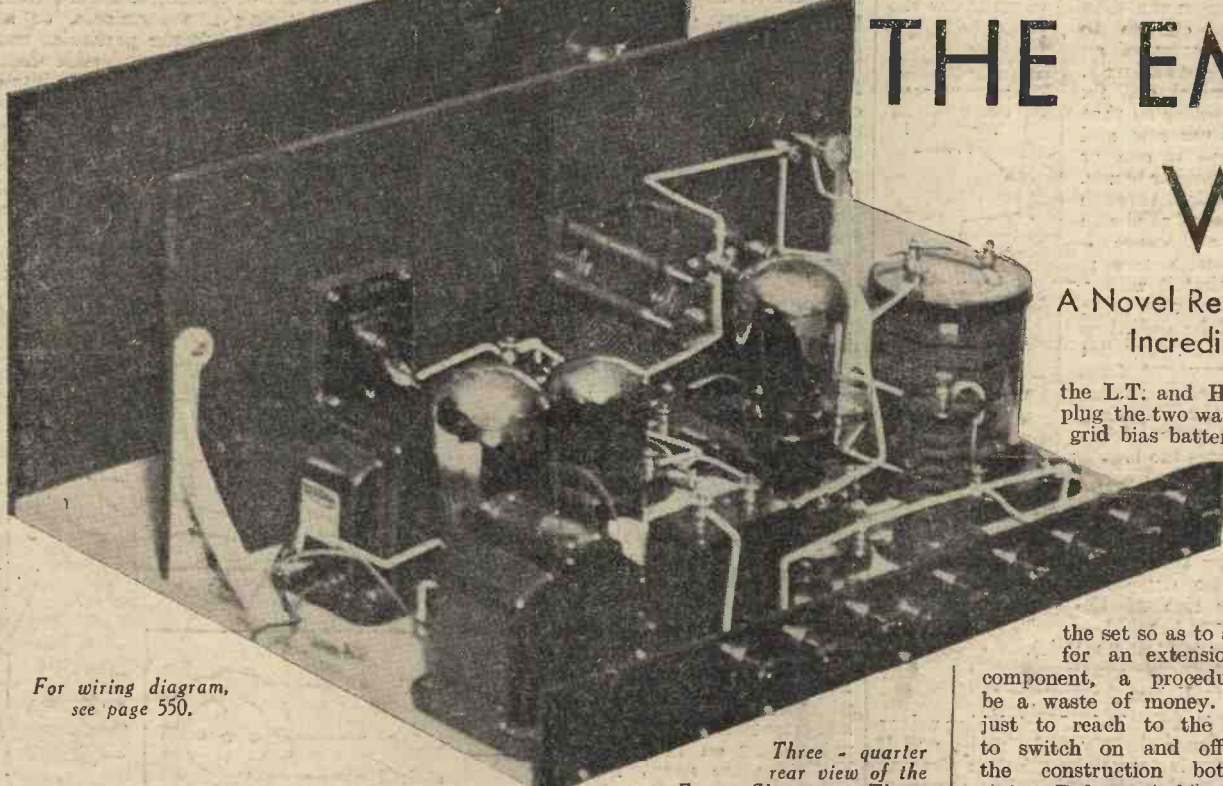

For wiring diagram, see page 550.

Three-quarter rear view of the Empire Short-wave Three.

### A Novel Receiver Which Works at Incredible Distances

the L.T. and H.T. batteries, and plug the two wander plugs into the grid bias battery. G.B.1 should be inserted in the tapping marked 1.5 and G.B.2 in the 9 volt socket. The on-off switch has been placed at the back of

the set so as to avoid the necessity for an extension handle for this component, a procedure which would be a waste of money. It is no trouble just to reach to the back of the set to switch on and off, and it makes the construction both cheaper and easier. Before switching on, turn the upper switch to the right, and the lower one to the left. In these positions the receiver is set for reception on the 25 to 80 metre band, and the special loading coil is cut out of circuit. Set the arm of the potentiometer to a position about mid-way round. Now switch on and carefully rotate the tuning dial, and although it is fitted with such a slow motion dial it is still necessary to

**L**AST week you were told exactly how to complete the fitting of the various parts of this interesting short-wave receiver, and no doubt you have by now finished this part of the work and are ready for wiring up. The wiring diagram is given on this page, and you should find this a comparatively simple task. Remember when using Glazite for wiring up a receiver, that it is best to cut off a short length, say, 18in. or so, and to stretch this until you feel it give. It then remains very stiff and straight, and nice sharp bends may be made in the wire and it stays put. There are no points to which attention must be drawn in the wiring, save, perhaps, to remind you to see that the two switches are wired up correctly. If you mounted these on the panel the right way round (as shown in this diagram) you will find that the operating instructions are O.K. If, however, you have the switches reversed, the instructions below will be reversed, that is, when we refer to the top switch being to the "right," that will only apply if the switch is mounted the right way round. This point should, therefore, be borne in mind.

#### Testing Out

With the wiring completed, carefully check over all connections, and when absolutely certain that everything is in order you can try the set out. In the valve-holder nearest the coil insert an H.2. valve, and in the centre valve-holder plug the L.2 valve. The remaining valve, the P.220, is inserted in the end socket. Loud-speaker or 'phones may be joined to the output terminals, and the receiver should then be joined up to aerial and earth. For the aerial, the one you normally use

for broadcast reception may be used for this short-wave set, although particular stress must be laid on the quality of the earth connection. You will see from the list of parts that we have specified Filt, and without a doubt this should be used with your earth connection in order to ensure that this is absolutely O.K. Join up

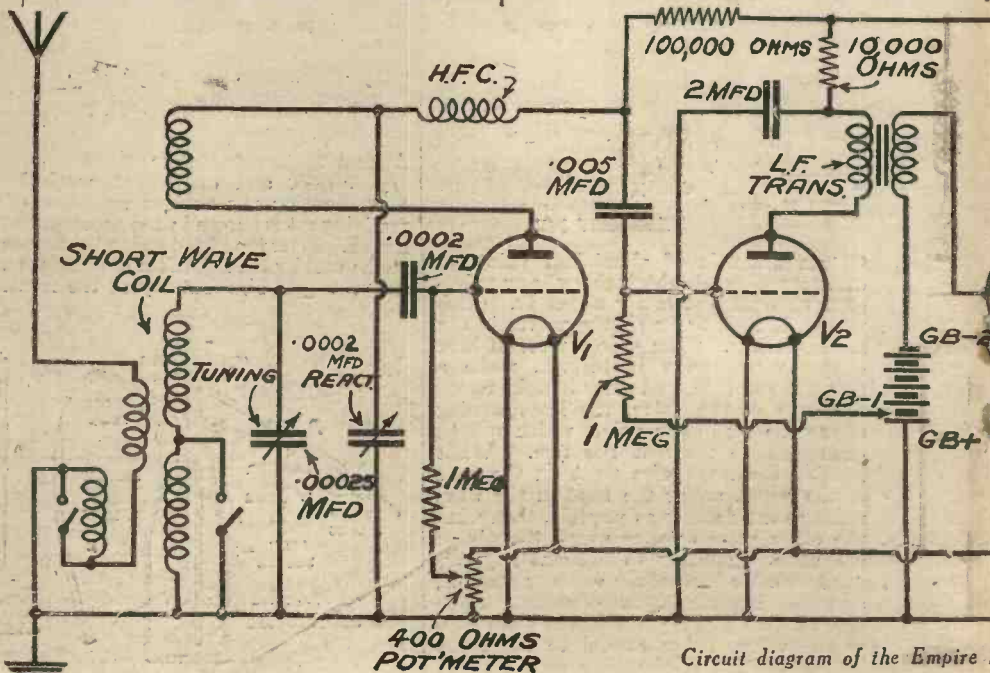

Circuit diagram of the Empire

# RATING— E SHORT- E THREE

Will Receive Transmissions from Almost  
on the 12-80-metre Waveband.

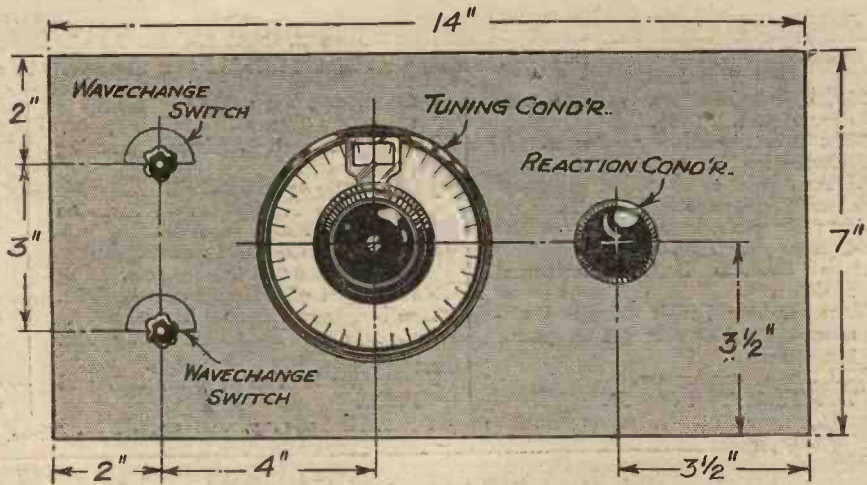

Panel lay-out of the Empire Short-wave Three.

turn slowly, as the short-wave stations are not spread round the dial in the same manner as the ordinary broadcasting stations. If you want a little assistance in searching, you can set the reaction control

a little way round so that you will heterodyne a carrier wave when tuned to one.

up one of the numerous amateur transmitters on this band, or some similar Morse signal which will enable you to see how the controls work. As soon as you find that the receiver seems to go dead whilst turning the dial, adjust the potentiometer arm, and if this is ineffective, the lower switch may be turned to the right, and it will be at once apparent that the deadness is removed. This switch must also be turned to the right when the receiver breaks into oscillation even with the reaction control at zero, a fault which is known as threshold howl, and which does not occur on every aerial. As soon as you have mastered the manipulation on this wave-band you may turn the upper switch to the left, and try for some of the powerful stations on the 12 to 30 metre band. There are a number of quite powerful broadcasting stations using wavelengths between these two limits, and although tuning seems even sharper on this band, you should experience no difficulty in getting a number of stations at quite a good strength. Fading and other atmospheric disturbances are of course experienced with any type of receiver, but you will find that all the usual short-wave faults, which are due to bad receiver design, or inefficient components, are overcome in this little set. Remember that the potentiometer should be set at the most suitable position, which will be a point near the positive terminal, and then it will not need to be touched again.

One final word—should you receive any short-wave station which you are unable to identify, do not fail to make use of our Broadcast Query Corner.

Three-quarter front view of the Empire Short-wave Three.

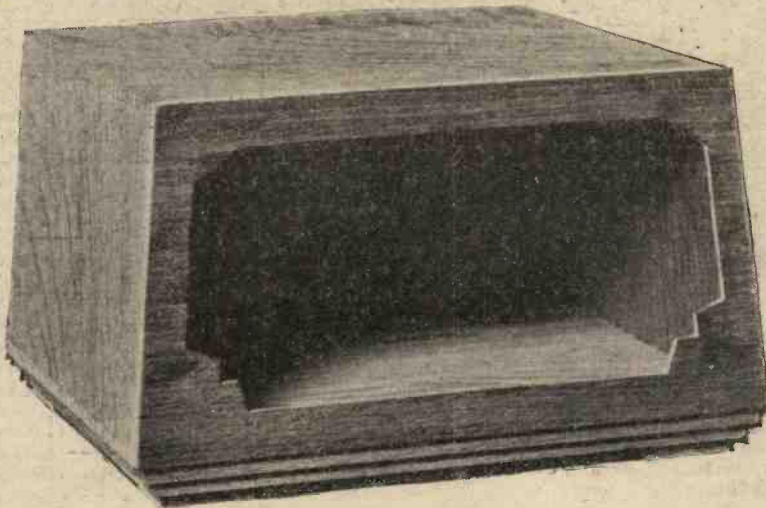

The cabinet for the Empire Short-wave Three.

This is not really necessary, however, and you should have no difficulty in picking

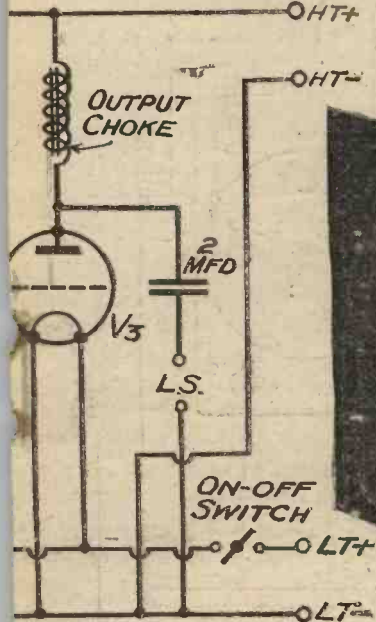

Short-wave Three.

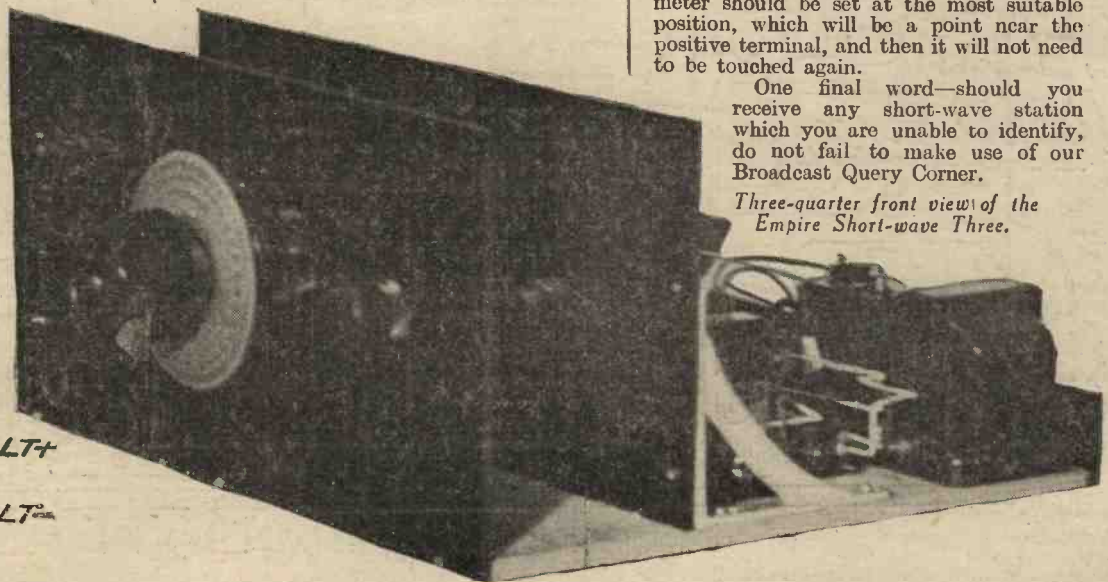

# LIST OF COMPONENTS FOR THE EMPIRE SHORT-WAVE THREE

Readers ordering parts should INSIST that these parts be supplied.

.00025 Jackson Bros. variable condenser (Cat. 2,045).  
 .0002 Telsen reaction condenser.  
 Utility Micro Dial type W181.  
 R.I. Antinodal coil.  
 Slektun Short-wave H.F. choke.  
 Lissen Hypernik transformer.  
 Telsen output choke.  
 Three Graham Farish Horizontal Holders.  
 Three Graham Farish Ohmite Resistances, 100,000 ohms, 1 megohm, 1 megohm.  
 T.C.C. fixed condensers.  
 Two 2 mfd Type No. 50.

One .0002 Type S.  
 One .005 Type S.  
 Lissen 400 ohm baseboard mounting potentiometer.  
 Ready Radio On-off Switch.  
 Two Bulgin Rotary On-off Switches Type S.85.  
 Lissen Spaghetti 10,000 ohms.  
 Three Eddystone valve holders.  
 Two Bulgin extension handles, EH2.  
 Two Bulgin extension handles, EH4.  
 Two Ebonite Panels 14in. by 7in. Becol.  
 Three Mazda Valves, H.2, L.2, and P.220.

Eight Terminals, Aerial, Earth H.T.—, H.T.+, L.T.—, L.T.+, L.S., L.S. Clix.  
 Three Grid-bias Plugs. G.B.—, G.B.—1, G.B.—2. Clix.  
 Two Peto-Scott Panel Brackets.  
 Wooden Baseboard 14in. by 12in.  
 Two coils of Glazite Connecting Wire, Flex, Screws, etc.  
 One Terminal Strip 14in. by 2in.  
 One Osborn No. 237 Cabinet.  
 120 v. Hellesen H.T. Battery and 9 volt G.B. Lissen 2 volt Acc.  
 Ormond R.452 Loudspeaker.  
 One tin of "Filt."

Wiring diagram of the Empire Short-wave Three.

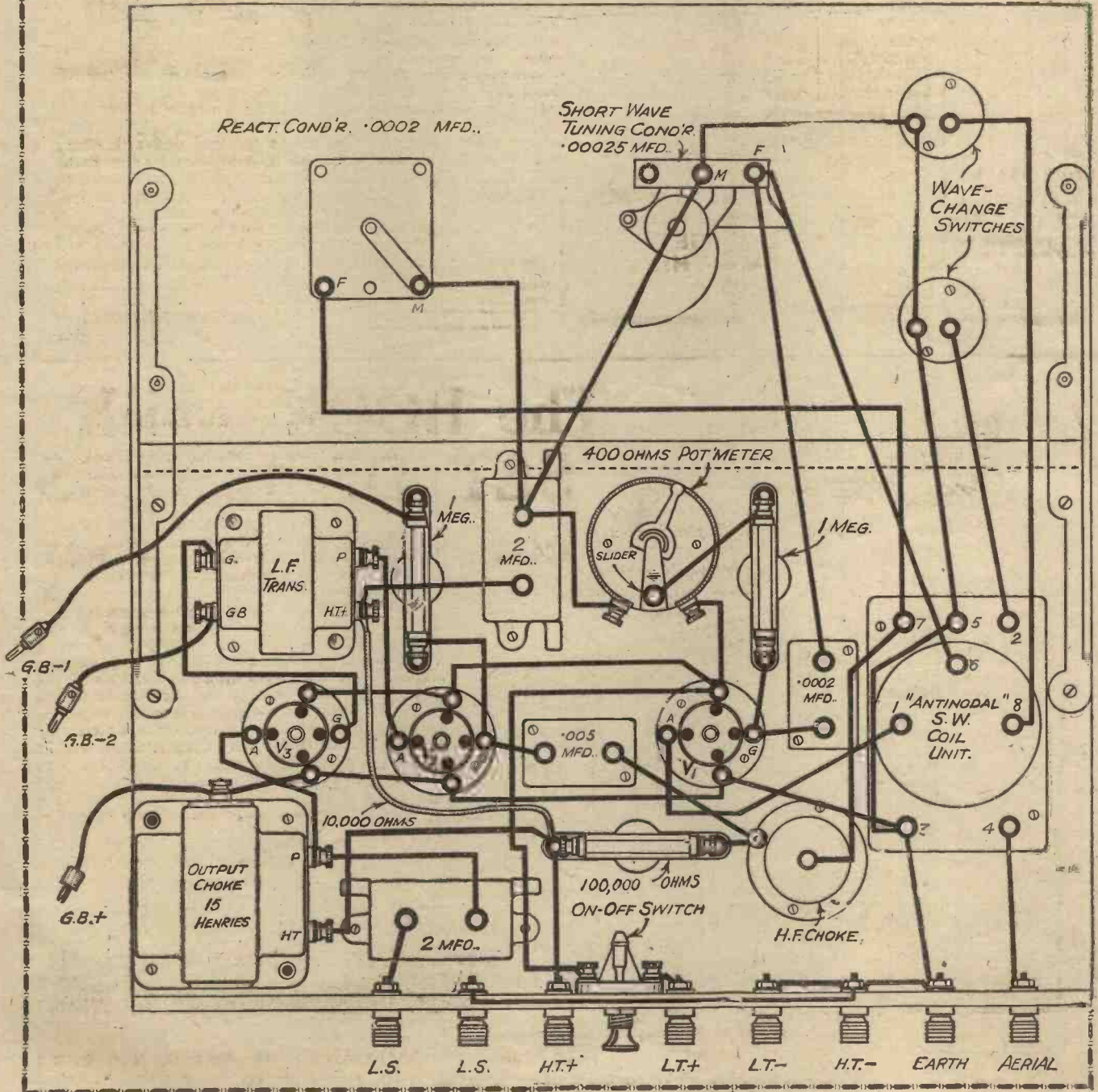

# from "THE DESIGN AND CONSTRUCTION OF RADIO POWER UNITS"

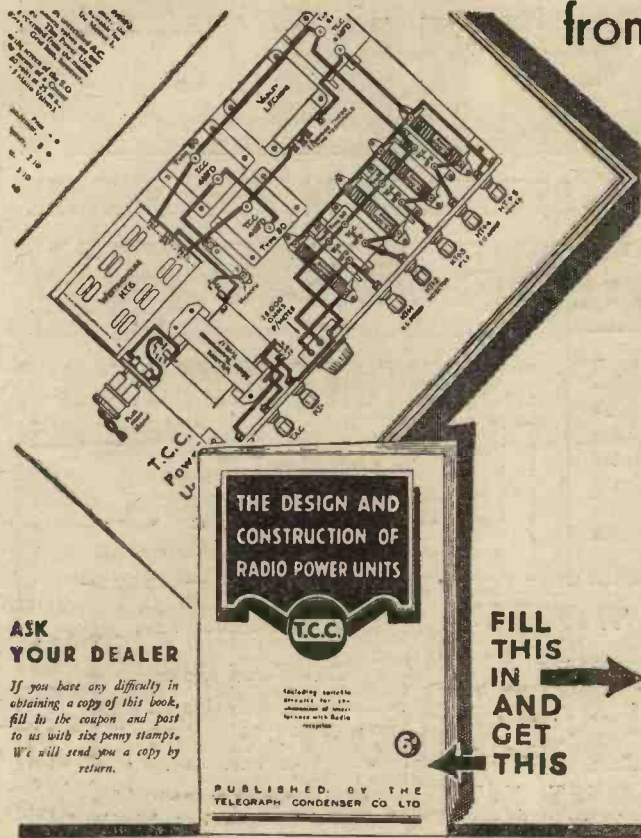

**ASK YOUR DEALER**

If you have any difficulty in obtaining a copy of this book, fill in the coupon and post to us with six penny stamps. We will send you a copy by return.

**FILL THIS IN AND GET THIS**

T.C.C. one of the oldest firms in radio have produced this authoritative book on power units. Packed full of real useful data, with complete constructional details of four Radio Power Units—it shows the way to better and more powerful reproduction—to *cheaper* radio. These power units solve your battery problem—no longer will you suffer distortion due to inadequate power. Build one of these A.C. Power Units and get the best from your set. For D.C. users there is a valuable chapter on D.C. Apparatus. Get your copy Now!

**CONTENTS**  
 RADIO POWER UNITS and how to build them  
 NOTES ON A.C. POWER, UNITS OPERATING RECEIVERS ON D.C. MAINS ABOUT T.C.C. ELECTROLYTIC CONDENSERS  
 ELIMINATION OF INTERFERENCE  
 FOUR T.C.C. POWER UNITS with full constructional details.  
 ROTATING RESISTANCE CALCULATOR

## T.C.C.

ALL-BRITISH  
**CONDENSERS**

**COUPON** To The Publicity Dept., The Telegraph Condenser Co., Ltd., Wales Farm Rd., N. Acton, London, W.3.

Please send me a copy of your book "The Design and Construction of Radio Power Units," for which I enclose six penny stamps to cover cost and postage.

Name.....  
 Address.....  
 Prac. 3/12/32.

PLEASE WRITE IN BLOCK LETTERS

1883

# The BOOK which SET DESIGNERS consult... get your copy!

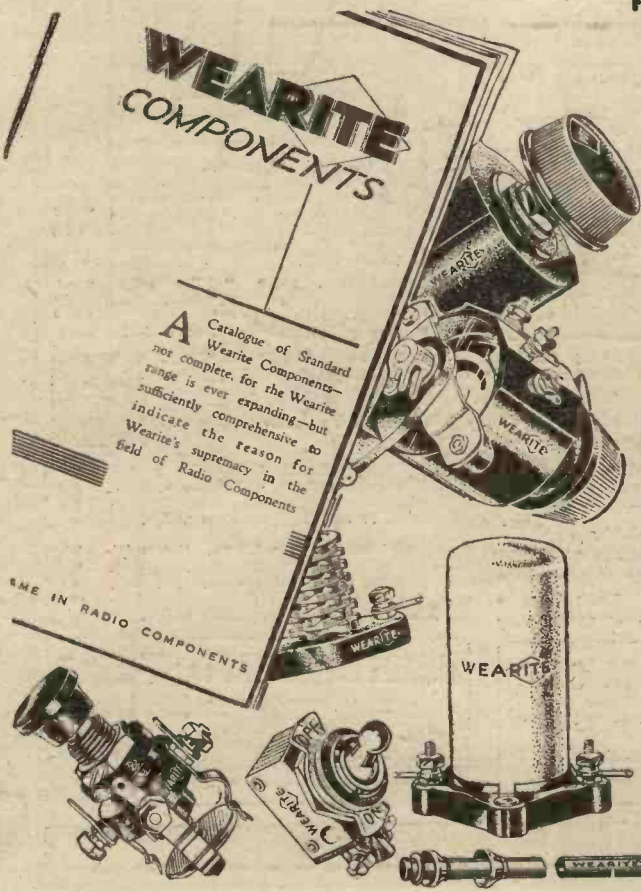

**WEARITE COMPONENTS**

A Catalogue of Standard Wearite Components—range is ever expanding—but sufficiently comprehensive to indicate the reason for Wearite's supremacy in the field of Radio Components

Look through the specification of the most popular receivers—see how often Wearite is specified. The designer has made sure of unquestioned reliability, he has consulted this Wearite Booklet No. G.N. Be guided, have your copy by you when you build your next set. Send for it now. Ask for the Wearite Booklet No. G.N.—it is your first step towards high efficiency in any set you construct.—Write NOW!

HERE IS THE NEW WEARITE 'STICK-ON' SELECTIVITY CONTROL AERIAL LEAD IN—it fits any window—no holes—no tools—and can be used with any receiver. Price complete - 1/- (with anchoring block for aerial) ..... 1/6

## WEARITE

Use this Wearite earth tube. Price - - - 3/6

**WRIGHT & WEAIRE Ltd.,**  
 740, HIGH ROAD, TOTTENHAM, N.17  
 Tel.: Tottenham 3847/8/9

1894

# PETO-SCOTT for

## OLDEST ESTABLISHED RADIO-BY-MAIL SPECIALISTS IN THIS JOURNAL ORDER YOUR CHRISTMAS RADIO NOW

### TELSEN JUPITER S.G.3

Sent Carriage Paid on first payment of **7/-** Complete Kit as advertised, less Valves and Cabinet. Cash Price, Carriage Paid, £3/17/0.

Balance in 11 monthly payments of 7/-

PETO-SCOTT—the largest Radio-by-Mail House in the world — have carefully selected these popular items to give you Better Radio this XMAS.

### SLEKTUN SCOUT S.G.3

S.G., Detector and Power. Kit "A," less Valves and Cabinet. Cash or C.O.D., Carr. Paid, £3/19/6. Sent Carriage Paid on first payment of **7/3**

Balance in 11 monthly payments of 7/3

BLUE SPOT SPEAKER UNIT AND CHASSIS. TYPE 100U. Cash Price £1/12/6. Carriage Paid. Balance in 6 monthly payments of 5/2.

Send **5/2** only

BLUE SPOT UNIT AND CHASSIS, Type 99 P.M. Including matched transformer. Cash Price, £2/19/6. Balance in 11 monthly payments of 5/6.

Send **5/6** only

ROLA PERMANENT MAGNET MOVING-COIL SPEAKER F.6. With universal tapped input transformer. Cash Price £2/9/6. Carriage Paid. Balance in 11 monthly payments of 4/6.

Send **4/6** only

EPOCH "20 C" PERMANENT MAGNET MOVING-COIL SPEAKER. (New Edition). With 5-ratio input transformer. Cash Price £1/15/0. Carriage Paid. Balance in 5 monthly payments of 6/5.

Send **6/6** only

R & A "VICTOR" PERMANENT-MAGNET MOVING-COIL SPEAKER DE LUXE. With 6-ratio input transformer and protecting grille. Cash Price £3/10/0. Carriage Paid. Balance in 11 monthly payments of 6/5.

Send **6/5** only

R & A "CHALLENGER" PERMANENT MAGNET MOVING COIL SPEAKER. With special Ferranti multi-ratio input transformer. Cash Price, Carriage Paid, £1/15/0. Balance in 5 monthly payments of 6/6.

Send **6/6** only

W.B. PERMANENT-MAGNET MOVING-COIL SPEAKER P.M.2. With 3-ratio input transformer. Cash Price £4/5/0. Carriage Paid. Balance in 11 monthly payments of 7/9.

Send **7/9** only

CELESTION P.P.M. PERMANENT MAGNET MOVING-COIL SPEAKER with impregnated diaphragm and dual-impedance input transformer. Cash Price, Carriage Paid, £2/7/6. Balance in 11 monthly payments of 4/6.

Send **4/6** only

R. & A. "BANTAM" PERMANENT-MAGNET MOVING-COIL SPEAKER with 3-ratio input transformer. Cash price £1/7/6. Balance in 5 monthly payments of 5/-.

Send **5/-** only

PETO-SCOTT WALNUT CABINET SPEAKER. Permanent Magnet Moving-Coil. Cash or C.O.D., £2/7/6. Balance in 11 monthly payments of 4/6.

Send **4/6** only

### COSSOR MELODY MAKER MODEL 335

Complete with Valves, Speaker and Cabinet. Employs Cossor Variable-mu S.G., H.F. stage, Detector and Power Valves. Cash Price, £7/17/6. Balance in 11 monthly payments of 14/10.

Delivered, carriage paid, on first payment of **10/-**

### READY RADIO "METEOR" S.G.3

Three-valve screened-grid receiver. Covers short, medium and long waves without coil changing. Cash Price, £2/15/3. Balance in 11 monthly payments of 7/-.

Delivered, carriage paid, on first payment of **7/-**

### READY RADIO "METEOR" S.G.3

Three-valve screened-grid receiver, WITH VALVES, CABINET, and PERMANENT-MAGNET MOVING-COIL SPEAKER. Covers short, medium and long waves without coil changing. Cash Price, Carriage paid, £3/17/6. Balance in 11 monthly payments of 16/3.

Delivered, carriage paid, on first payment of **16/3**

### THIS YEAR'S WINNER. LISSEN

### "SKYSCRAPER" COMPLETE WITH VALVES S.G.3

CHASSIS KIT with (Lissen) S.G., Detector and Pentode Valves. Cash Price, Carriage Paid, £4/9/6. Delivered, carriage paid, on first payment of Balance in 11 monthly payments of **8/3**

CABINET KIT with (Lissen) Valves, Walnut Cabinet and special Balanced Armature Loud-speaker. Cash Price, Carriage Paid, £6/5/0. Delivered, carriage paid, on first payment of Balance in 11 monthly payments of **11/6**

**ONLY FROM PETO-SCOTT ON GENEROUS EASY TERMS**  
*Carriage paid to your door*

BLUE SPOT PICK-UP. With arm, rotating head and volume control. Cash Price £3/3/0. Carriage Paid. Balance in 11 monthly payments of 5/9

MARCONIPHONE PICK-UP K.17. With counter balanced arm and rotating head. Cash Price £2/2/0. Carriage Paid. Balance in 7 monthly payments of 5/9.

READY RADIO KENDALL-PRICE S.G.4. S.G., Detector, L.F. and Power. Complete kit less valves and cabinet. Cash Price £4/6/6. Carriage Paid. Balance in 11 monthly payments of 8/-.

RADIO FOR THE MILLION "STATION MASTER 3." (Model A.) With valves and cabinet for battery use. Cash Price £5/11/0. Carriage Paid. Balance in 11 monthly payments of 10/2.

GARRARD AUTOMATIC RECORD CHANGER for A.C. mains. Mounted on unit plate complete ready for fitting in position, including Garrard pick-up and tone-arm. Cash Price £10/0/0. Carriage Paid. Balance in 11 monthly payments of 18/6

SONOCHORDE PERMANENT-MAGNET MOVING-COIL SPEAKER, with universal input transformer. Cash Price £12/6. Balance in 5 monthly payments of 6/-.

ATLAS ELIMINATOR, Type A.C.244. Three tappings. S.G., Detector and Power. Output: 120 volts at 20 m/A. Cash Price £2/19/6. Carriage Paid. Balance in 11 monthly payments of 5/6.

HEAYBERD H.T. UNIT D.150. Tapped variable 60/120 v., variable 0/150 fixed. Max., 25 m/a. at 150 v., 20 m/a. at 120 v. Cash Price, Carriage Paid, £4/6/0. Balance in 11 monthly payments of 8/10

EKCO A.C.18 H.T. ELIMINATOR for A.C. mains. Tapped S.G. 80 v. 120/150 v. at 12 m/a. Cash Price, Carriage Paid, £3/7/6. Balance in 11 monthly payments of 6/3.

GARRARD INDUCTION GRAMOPHONE MOTOR. For A.C. mains. Model 202. Mounted on 12-inch nickel motor plate with fully automatic electric starting and stopping switch. Cash Price £2/10/0. Carriage Paid. Balance in 11 monthly payments of 4/7.

GARRARD JUNIOR "B" SPRING MOTOR. Complete with turntable. Cash Price £1/13/0. Carriage Paid. Balance in 5 monthly payments of 6/1.

W.B. PERMANENT MAGNET MOVING COIL SPEAKER. Type PM4. Complete with transformer. Cash Price £2/2/0. Carriage Paid. Balance in 7 monthly payments of 5/9.

EKCO A.C.12 H.T. ELIMINATOR for A.C. mains. Tapped S.G. 80 v. 120/150 v. at 12 m/a. Cash Price £2/15/0. Balance in 11 monthly payments of 5/-.

EKCO H.T. UNIT. Type A.C.25. For multi-valve sets requiring up to 25 m/a. 3 tappings S.G., detector and 120/150 volts. For A.C. mains. Cash price, £3/17/6. Balance in 11 monthly payments of 7/-.

**STRICT PRIVACY GUARANTEED — WE DEAL WITH YOU DIRECT**

# EVERYTHING RADIO

## ULTRA "TIGER"



A.C. or D.C. Mains. S.G., S.G. Detector and Pentode, Moving-coil Speaker. Complete with Mazda Valves. Ready for use. Cash Price, Carriage Paid, £15/15/0.

**20/-**

WITH ORDER

Balance in 17 monthly payments of 20/-.

**ULTRA "PANTHER"** Cash or C.O.D. £18-18-0  
Or 18 monthly payments of 24/3

## PETO-SCOTT S.G.3 RADIO



SEND

**12/-**

NOW

## PHILIPS TYPE 830A VALVE RECEIVER

For A.C. Mains. Two Screen-grid, Power-grid Detector and Pentode. With Moving-coil Speaker. Provision for Pick-up and external Speaker. Cash Price, Carriage Paid, £16/16/0.



**21/6**

WITH ORDER

Balance in 17 monthly payments of 21/6.

## ULTRA 1933 "BLUE FOX"



A.C. or D.C. Mains. Detector and Pentode Valves. Moving-coil Speaker. Complete with Valves and Cabinet. Ready for use. Cash Price, Carriage Paid, £10/10/0.

**15/9**

WITH ORDER

Balance in 14 monthly payments of 15/9 only.

**THE PETO-SCOTT 3-VALVE RADIO** is a great technical achievement. Self-contained in one Cabinet of beautifully-grained walnut. High-grade components on all-steel chassis. Slow-motion single-dial tuning. Screened grid, detector and power valves, MOVING-COIL SPEAKER. Designed to give reliable Radio Reception in every part of the British Isles of B.B.C. and Foreign Programmes.—Supplied complete, ready to play, with Exide and Drydex Batteries and Aerial Equipment. Fitted Mullard Valves.

**A STRAIGHTFORWARD OFFER.** This is an honest-to-goodness offer from a firm established in 1919—since before Broadcasting began—solely for the purpose of building Wireless Sets and bringing radio within the reach of all. Peto-Scott himself gives every purchaser of his Set a personal guarantee of satisfaction.

**NO EXTRA FOR EASY TERMS.** You are not penalised because you cannot afford to pay cash. We give you credit over sixteen months, making no extra charge for Easy Terms. Carriage Paid complete with Aerial Equipment, £9/12/0. You send us 12/- with order and 3/- per week (paid monthly) for 15 months. This means you own the best British Radio money can buy.

## AERODYNE SCREENED GRID 3



With Variable-mu. Complete and ready to play, with Valves, Batteries and Accumulator, with Moving-coil Speaker. Cash Price, Carriage Paid, £9/9/0.

**14/3**

WITH ORDER

Balance in 14 monthly payments 14/3

**ALL-MAINS MODEL** with Variable-mu S.G. Valve. Cash Price, Carr. Paid, £15/15/0.

**20/- WITH ORDER**

Balance in 17 monthly payments of 20/-.

## PETO-SCOTT WALNUT CABINET SPEAKER

Fitted with the famous BLUE SPOT 100U.

In handsome Walnut Cabinet with Contrasting Inlaid Walnut Veneer.

CASH OR C.O.D. CARR. PAID.

**47/6**

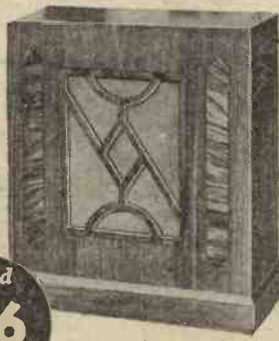

Send **4/6** Only

Balance in 11 monthly payments of 4/6

Equal in performance to a good Moving Coil Speaker, Sensitive to very small inputs and is therefore entirely satisfactory for battery operated sets, as well as all mains sets. It needs no matching transformer; can be used with normal or Pentode valves.

## TELSEN MACNAMARA

FOR A.C. MAINS. S.G., Detector and Pentode. Complete, ready to play, with Moving-coil Speaker. In Unstained Cabinet. Cash Price Carriage Paid, £12/12/0.

**16/-**

WITH ORDER

Balance in 17 monthly payments of 16/-.

In Polished Walnut Cabinet: Cash or C.O.D. £15/15/0. Carriage Paid. Or by 18 monthly payments of 20/-.



## PYE "G"

FOR A.C. MAINS.

Valve, with Band-Pass Tuning, Variable-Mu, Power Grid and Pentode. Complete, ready to play with Moving-Coil Speaker. Walnut Cabinet. Cash Price, Carriage Paid, £16/18/0.

**24/3**

WITH ORDER

Balance in 17 monthly payments of 24/3



## S.T. 400 FINISHED INSTRUMENT



Carriage Paid CASH or C.O.D.

Assembled with Pilot Author Kit. Exact to Mr. John Scott-Taggart's Specification. Aerial tested. Complete with set of Valves & Table Model Oak Cabinet. Batteries extra. £9-12-6 Or 12 monthly payments of 17/9.

## PETO-SCOTT CO. Ltd. 77, City Rd., London, E.C.1

West End Showrooms: 62, High Holborn, London, W.C.1. Telephone: Clerkenwell 9406-7 Telephone: Holborn 3248

Dear Sirs, Please send me CASH/C.O.D./H.P. for which I enclose £.....d. CASH/H.P. Deposit. Also send your FREE 1933 Radio Catalogue.

NAME .....

ADDRESS .....

Pr.W. 3/12/32 .....

**EVERYTHING CARRIAGE PAID.** Pioneers of Radio on Easy Terms in 1924. We shall be pleased to quote you by return for all your Radio requirements. We carry stocks of all leading manufacturers' products advertised in this journal. Any parcel of components or accessories. Over £2 supplied on Easy Terms. Send for NEW CATALOGUE

*Yours for Better Radio this Xmas—Peto-Scott*

**TELSEN**

# DUAL-RANGE COILS



TELSEN DUAL-RANGE AERIAL COIL incorporates a variable selectivity device, making the coil suitable for widely varying reception conditions. This adjustment also acts as an excellent volume control, and is equally effective on long and short waves. The wave-band change is effected by means of a three-point switch and a reaction winding is included ... **7/6**

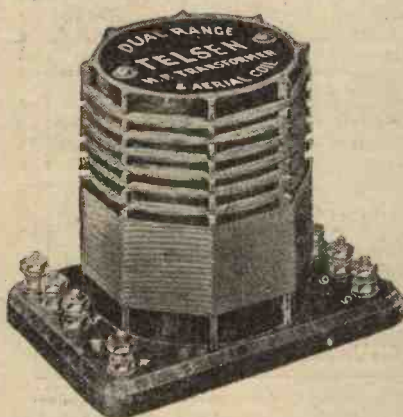

TELSEN H.F. COIL may be used for H.F. amplification with Screened-Grid Valve, either as an H.F. Transformer or, alternatively, as a tuned grid or tuned anode coil. It also makes a highly efficient Aerial Coil where the adjustable selectivity feature is not required **5/6**

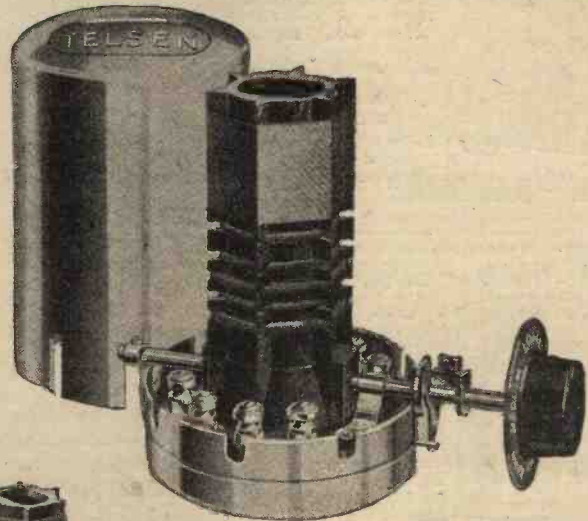

*Twin Matched Screened Coils*  
**17/6**

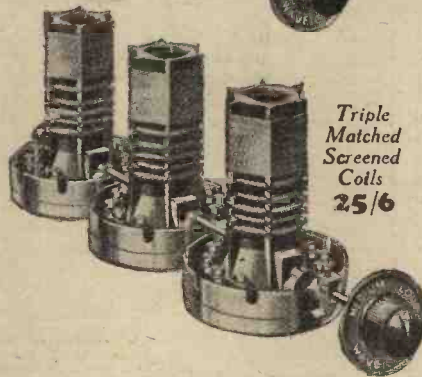
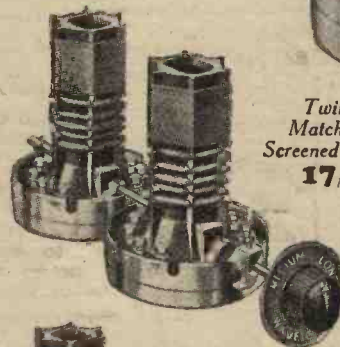

*Triple Matched Screened Coils*  
**25/6**

## TELSEN SCREENED COILS

The result of much research and experiment, these coils embody the ultimate efficiency attainable in a perfectly shielded inductance of moderate dimensions. Provided with separate coupling coils for medium and long waves, they are suitable for use as aerial coils or as anode coils following a screened-grid valve, giving selectivity comparable only with a well-designed band-pass filter. The coils are fitted with cam-operated rotary switches with definite contacts and click mechanism, and are supplied complete with aluminium screening cans, bakelite knob, and handsome "Wave Change" escutcheon plate, finished in oxidised silver **8/6**

*Full instructions are supplied with every Telsens Screened Tuning Coil, showing you the alternative methods of mounting the coils, either singly, or in twin-matched or triple-matched form as required.*

# TELSEN

**RADIO COMPONENTS**

**TELSEN RADIO COMPONENTS ARE 100% BRITISH**

ANNOUNCEMENT OF THE TELSEN ELECTRIC CO., LTD., ASTON, BIRMINGHAM





**Audion**

**A** NAME for the original three-electrode valves.

**Autodyne**

Technically this would be described as a combined heterodyne and grid detector circuit, but what it means in everyday language is nothing more

**THE BEGINNER'S A B C OF WIRELESS TERMS**

and to tap this at a suitable point. Fig. 3 shows these two different arrangements of an auto-transformer. The single coil transformer is the one to which the name was originally applied. The examples shown are L.F. transformers, as indicated by the presence of the iron-alloy cores on which the coils are wound. An H.F. transformer has no iron core.

back E.M.F. is generated when an electric motor is running. When the motor is switched on a comparatively large current flows through it, but as soon as it has got under way this is reduced owing to its tendency to act also as a dynamo—that is to say, the fact of its turning round causes it to generate an electromotive force. This electromotive force or voltage opposes the flow of current through the motor, and is, therefore, known as a back E.M.F. This opposition, of course, reduces the amount of current consumed by the motor. This is only one instance of the creation of back E.M.F. in electrical apparatus. There are, of course, many others.

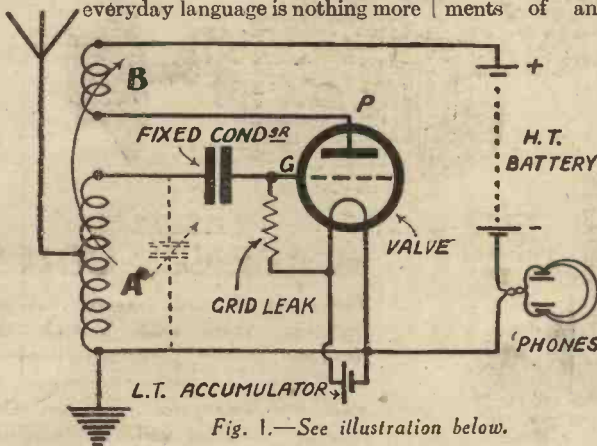

Fig. 1.—See illustration below.

**Baffle or Baffle Board**

A screen of non-resonant material, usually wood, which is placed round a cone type loud-speaker. The object of this is to provide a long path for the sound waves from the back to the front of the speaker. This helps to preserve the bass notes. Without a baffle reproduction is inclined to be high-pitched. There are several methods of construction, two of which are given in Figs. 4 and 5. In one case a simple board is used with a hole cut in it to take the cone of the speaker. In the other case a box or cabinet open at the back is employed. The latter achieves the same object as the former—namely, the provision of a long path from back to front of the speaker without being so bulky. The arrows indicate the path the sound waves would have to take from back to front. In order to prevent resonance it is

than a valve detector circuit using reaction. Figs. 1 and 2 show a typical autodyne circuit. A is the tuning coil, and B is the reaction coil. On bringing the coil B near to A it has a boosting effect. Without going into a lengthy explanation, it may be said that it has a similar effect to that obtained in the automobile world when a supercharger is used on a motor-car. It enables one to get more out of the valve in the same way as the supercharger gets more out of the car engine. In the case of the car the extra energy is obtained by using more petrol and air. With the autodyne circuit the additional power comes from the high-tension battery.

**"B" Battery**

A term used in America and on the Continent to indicate the high-tension battery used to supply the anode current of a valve. We call it the "H.T." battery.

**Back Coupling**

A term usually used to indicate the use of a reaction coupling. The reaction coil is said to be "back coupled" to the aerial or anode coil. In Figs. 1 and 2, B is the back-coupling coil.

**Back E.M.F.**

An electromotive force or voltage which opposes the flow of current in an electrical circuit. For instance: a

**Auto-Transformer**

A transformer in which one coil is used as both primary and secondary. In the ordinary way a transformer, whether it is a high-frequency transformer or a low-frequency one, has two windings, primary and secondary. If these two windings are joined together to form one coil with one connection common to both coils, it is called an auto-transformer.

An even simpler arrangement is to use only one large coil with sufficient turns to form both primary and secondary,

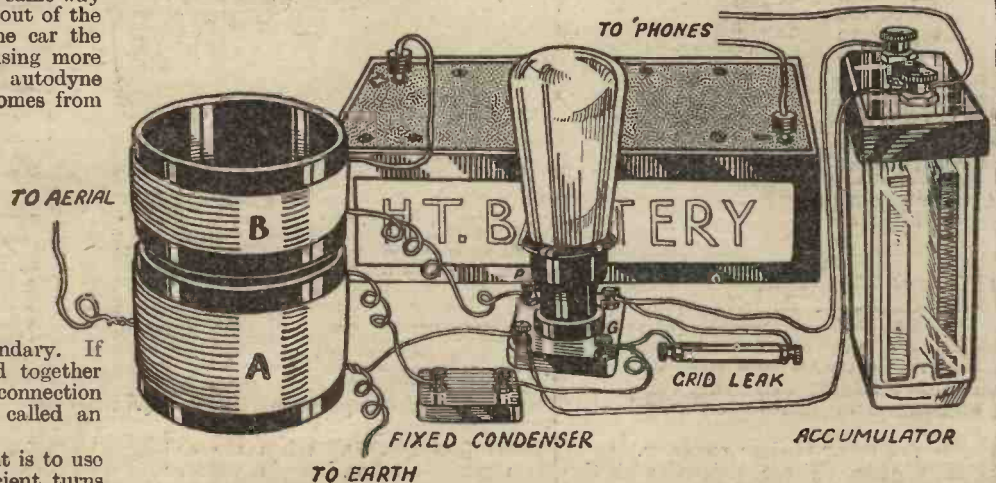

Figs. 1 and 2 illustrate a simple autodyne circuit. The tuning condenser is omitted for clarity.

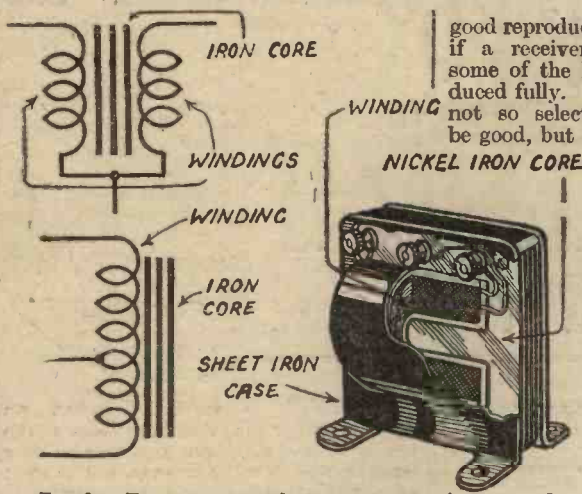

Fig. 3.—Two circuits and cutaway view of iron-cored auto-transformer.

good reproduction. In the ordinary way, if a receiver is made very selective, some of the higher notes are not reproduced fully. On the other hand, if it is not so selective the reproduction will be good, but there is the chance of interference from other stations. With the band-pass filter the tuning is very selective, as it is insensitive to any but a very narrow band of frequencies. This band is just sufficiently wide to give faithful reproduction, but not wide enough to include stations on either side of the one being received. What this means in practice is that a good band-pass filter will be found to give selectivity with good-quality reproduction, but will

The "spokes" are pulled out and the wooden disc slipped out from the centre, leaving the completed coil as shown. Although very easily made and quite efficient, this type of coil is not used to any extent nowadays; no doubt partly because of its rather flimsy nature and the difficulty of making a satisfactory holder for it. However, the principle is still used in one of the most efficient plug-in coils on the market. In this case the makers have overcome the mounting difficulty by totally enclosing the coil in a thin Bakelite case. The connections are made with the usual plug and socket. In the models employing tappings, these are brought out to terminals mounted round the circumference of the Bakelite case.

One term applied to the basket coil was the "Basket Weave," and for this type of coil two sets of pins were employed, and these were arranged in two rings, the pins of one ring being in between the pins of the ring on the opposite side of the former. The former was usually about

advisable to use fairly thick wood or else some such material as one of the composition boards used in building and decorating. Even stout eardboard may be quite successful, but metal, especially if in the form of thin sheet stuff, should not be used.

**Balanced Armature**

A type of movement used in a large number of loud-speakers. It consists of an iron reed or armature which is balanced both mechanically and magnetically between the poles of a permanent magnet. Fig. 6 shows the arrangement employed in a true four-pole balanced armature unit. N.S. are the poles of the permanent magnet. A is the armature, P is a pivot, and C is the cone of the speaker. The balanced armature unit is one of the most sensitive known, although its response often falls off somewhat towards both the upper and lower frequencies. It will not usually handle as much power as the moving coil type.

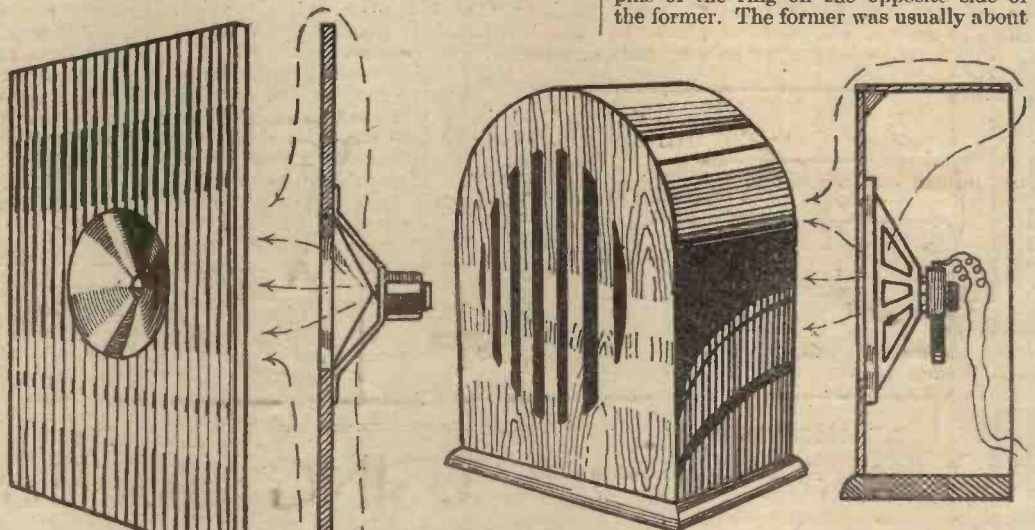

Figs. 4 and 5 show two forms of baffle.

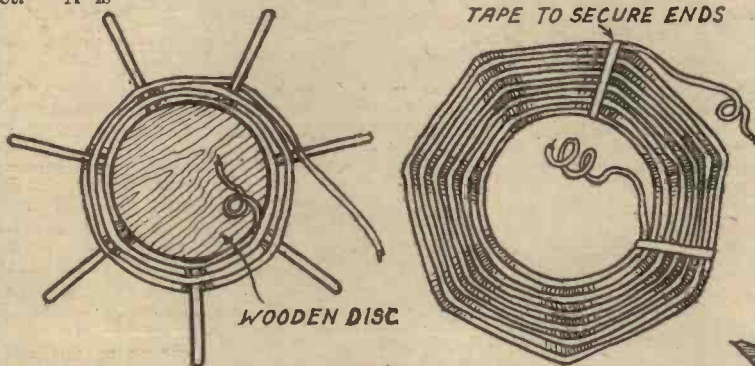

Fig. 7.—Left, basket coil partly wound. Right, completed coil.

lin. wide. To wind the coil the wire was taken round one pin on one side of the former, and then across to the pin on the opposite side. From this pin it was brought back on to the first side, to the next pin, then back across the former, and so on right round the former. By using an odd number of pins on each side the coil became practically solid, and had the appearance when finished, of a large wicker basket. By missing alternate pins on each side, the self-capacity of the coil was much reduced.

**Band-pass Filter**

A filter circuit which is designed so that it will only pass a certain band of frequencies. Perhaps the best-known application of this principle is in the popular band-pass coils used for the tuning of many modern receivers.

Band-pass coils are designed with the object of obtaining good selectivity with

not be quite so sensitive as straight tuning.

**Basket Coil**

A tuning coil made by winding the wire in and out of an odd number of pins sticking out radially from a wooden disc like the spokes of a wheel (see Fig. 7). When the coil is wound it is soaked in wax or varnish to make it self-supporting.

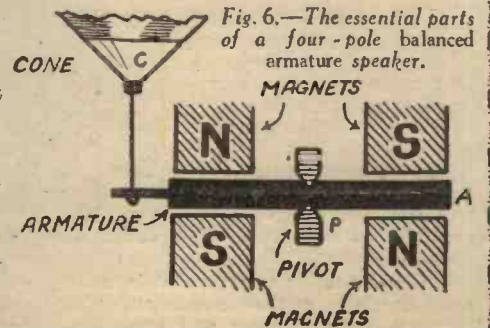
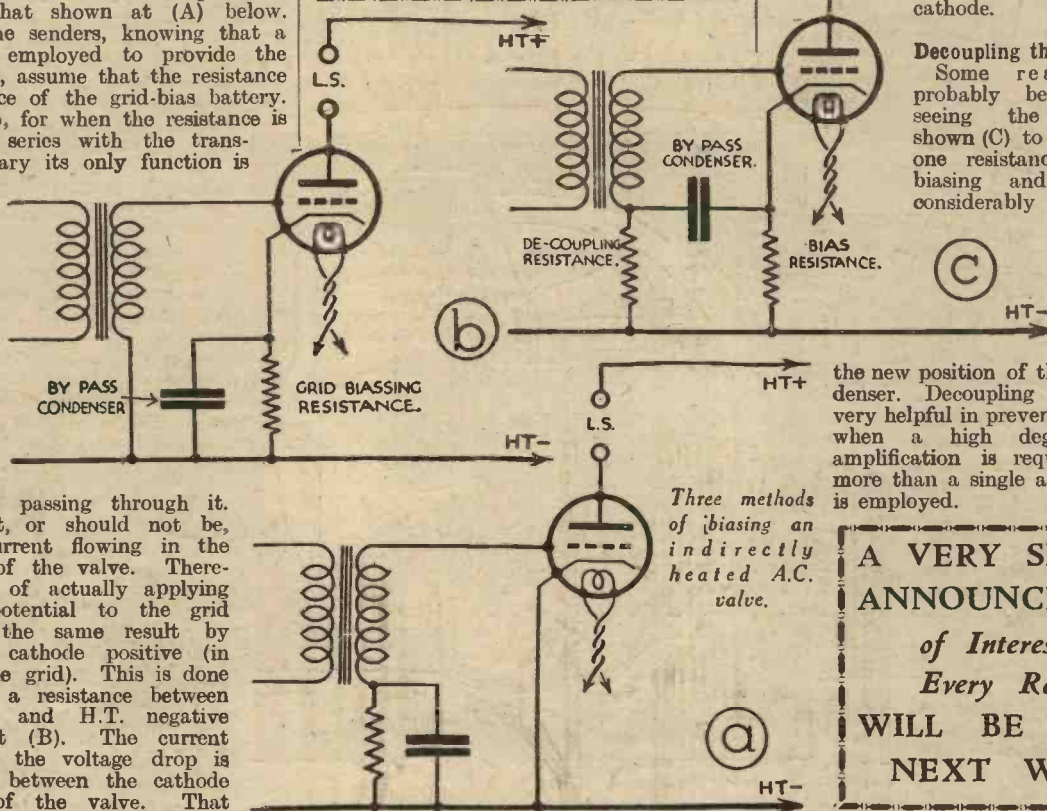

Fig. 6.—The essential parts of a four-pole balanced armature speaker.

THAT the principles of automatic grid biasing in A.C. receivers are not fully understood is evident from a number of queries received by our Free Advice Bureau. Not a few readers, in asking for a criticism and help in connection with the building of an A.C. receiver, have sent a circuit of which the L.F. amplifier is similar to that shown at (A) below. Apparently the senders, knowing that a resistance is employed to provide the necessary bias, assume that the resistance takes the place of the grid-bias battery. This is not so, for when the resistance is connected in series with the transformer secondary its only function is to decouple the grid circuit. To understand the proper method of providing automatic bias one must realise that a resistance can only cause a drop in voltage when a current is passing through it. There is not, or should not be, any D.C. current flowing in the grid circuit of the valve. Therefore instead of actually applying a negative potential to the grid we achieve the same result by making the cathode positive (in respect of the grid). This is done by inserting a resistance between the cathode and H.T. negative as shown at (B). The current which causes the voltage drop is that flowing between the cathode and anode of the valve. That

# BIAS FOR A.C. VALVES



end of the resistance marked + is positive in respect to that marked -, and conversely the latter point (to which the transformer secondary is connected) is negative in respect to the cathode.

**Decoupling the Grid Circuit**  
Some readers have probably been misled by seeing the arrangement shown (C) to the left. Here one resistance is used for biasing and another, of considerably higher value, serves to decouple the grid circuit from those of other valves in the set. Notice also

the new position of the by-pass condenser. Decoupling of this kind is very helpful in preventing instability when a high degree of L.F. amplification is required or when more than a single amplifying stage is employed.

Three methods of biasing an indirectly heated A.C. valve.

**A VERY SPECIAL ANNOUNCEMENT**  
of Interest to Every Reader  
WILL BE MADE NEXT WEEK!

# MAKING AND USING A WAVEMETER

THE best kind is the heterodyne wavemeter, of which a typical circuit diagram is given below. The latter, it will be observed, is practically the same as that of a single valve regenerative receiver, but is somewhat simpler.

**Make a Wavemeter**

Most of my readers will be able to make the wavemeter from parts taken from the junk box, for the only components required are:—A two-coil holder and a few plug-in coils, .0005 mfd. S.L.F. condenser, grid condenser and leak, valveholder. All the parts can be mounted on any odd panel and baseboard that happen to be to hand. After wiring up, put a valve of the "H.L." or "general purpose" type in the valve-holder, and connect up to H.T. and L.T. batteries. For medium waves coil L1 should be a 35 or 50 and for long-waves, a size 200. A 75 coil will serve for reaction (L2) on both wavebands.

**Calibration**

Before the wavemeter can serve any useful purpose it must be calibrated. To do this place it some distance from the set and tune in a station of known wavelength on the latter. Now turn the condenser dial on the wavemeter until a whistle is heard in the speaker. By turning the dial a little further the

whistle should die away, and then return again. The condenser reading at the "silent point" corresponds to the wavelength (or frequency) of the station being received. By repeating the process on a number of other known stations, a calibration graph can be drawn by plotting wavelengths against the corresponding condenser settings. As a matter of fact, it will be better to work in frequencies, rather than wave-

lengths, because the graph will then be practically a straight line.

**Using the Wavemeter**

Having calibrated the wavemeter, let us suppose that a station of which the identity is unknown has been tuned in. Adjust the wavemeter to resonance with the set (in other words, tune it to the silent point); by consulting the graph, the frequency of the station can at once be obtained. It now only remains to look through a list of stations to find the one whose frequency has been determined. If there are two stations on the same wavelength, each one can generally be distinguished by the language of the announcer.

**Receiving Difficult Stations**

By reversing the process just outlined, the set can be adjusted to any particular wavelength when you wish to listen for a station that is normally difficult to receive. This is very useful, and saves the trouble of much unnecessary searching.

The wavemeter which I have described can be used as a single valve "stand-by" receiver by connecting aerial and earth leads as shown in broken lines and inserting a pair of phones in the positive H.T. lead at the point indicated by a cross.

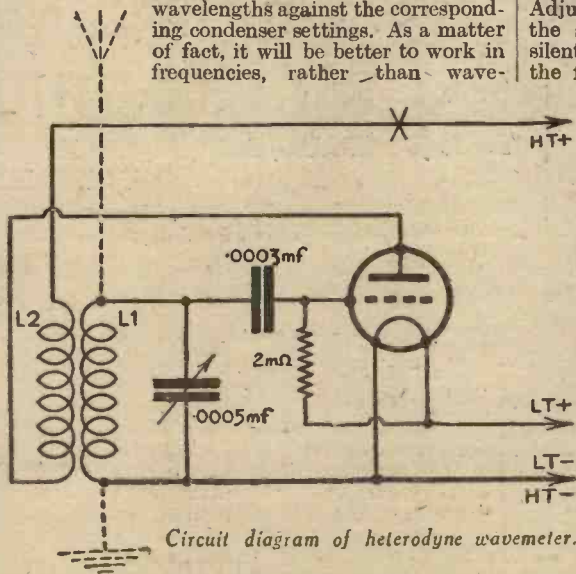

Circuit diagram of heterodyne wavemeter.

# AN AMAZING BARGAIN

## 1933 BROWN P.M. MOVING COIL UNIT & CHASSIS

LIST PRICE 50s.  
OUR PRICE 32s. 6d.

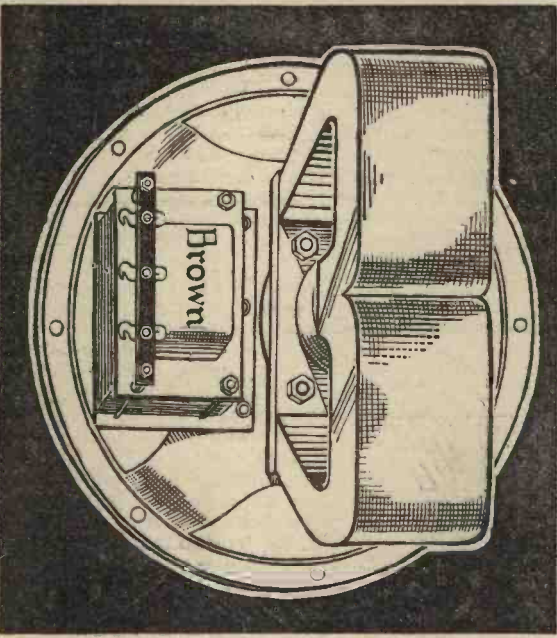

SEND ONLY 2s. 6d. FOR 7 DAYS TRIAL

Obtainable on EASY TERMS

Do not miss this remarkable opportunity for obtaining a really first-class PERMANENT MAGNET MOVING COIL SPEAKER at a greatly reduced price. This entirely new 1933 BROWN Unit and Chassis, with TAPPED TRANSFORMER incorporated, is a bargain that will instantly appeal to the man who already has a good Set, but a poor Speaker, and to the home constructor who is building his set. It is highly suitable to work with any Set, from 2 valves upwards, giving deep, rich tone and wonderful volume without distortion.

**Glorious Tone from any Set! TRY IT AND PROVE IT!**

An exclusive feature of this superb Speaker is the entire protection of the pole faces to prevent dust and metal particles from entering the gap, and it is hum-free, having no energising coils. Overall dimensions: 8½ in. diameter, 4½ in. deep, fitted on Baffle Board 12 in. square. Send only 2s. 6d. deposit and try it for 7 days. If satisfied, send further 5s. 0d. at once, then complete purchase by 6 monthly payments of 5s. 0d. (Cash in 7 days, 32s. 6d.). The list price is 50s. 0d., and only a limited number are available at this greatly reduced price. Send without delay.

### INVALUABLE AID FOR THE HOME CONSTRUCTOR!

The British-Made WATTS UNIVERSAL METER is the only popular-priced instrument testing resistances as well as batteries, circuit, valves, transformers and all components. With it you can quickly detect faults that otherwise would baffle you. It is encased in a black bakelite case with 4 readings on one dial.



SEND ONLY 1s. 6d.

for it on 7 days trial, if satisfied, complete purchase by 5 monthly payments of 2s. 6d. (Cash in 7 days, 12s. 6d.)

### POST THIS COUPON TODAY

To E. J. HERAUD, Ltd., Dept. P.11, NUMBER ONE, EDMONTON, LONDON, N.18

Please send me a Brown Permanent Magnet Moving Coil Unit and Chassis, for which I enclose 2s 6d. deposit. If after 7 days' trial I am satisfied, I will

- (1) Send further 5s. 0d. at once, and 6 monthly payments of 5s. 0d.
  - (2) Send 30s. 0d. at once to complete purchase.
- (Please strike out which does not apply.)

Please fill in here Number of Postal Order

Please make Postal Order payable to E. J. Heraud, Ltd., and Cross it

Name .....

Address .....

& Co.

The above is our full postal address. Branches at 78/82 Fore Street, Edmonton; 77, West Green Road, Tottenham; 34, St. James Street, Walthamstow; and 139, Hertford Road, Enfield Wash.

# How To Work ALUMINIUM

A Few Facts About Aluminium and How the Home Constructor Can Work It With Very Simple Tools.

By DEREK ARCHER

TO those unacquainted with aluminium, and its uses, the following facts will be of interest. Aluminium is 65 per cent. lighter than steel, 67 per cent. lighter than brass, 69 per cent. lighter than copper, and its resistance is about 1.6 times that of copper.

Aluminium is non-magnetic, does not rust, can be easily cut, can be easily bent, can be easily formed, and has an attractive appearance however the surface is treated. Bulk for bulk it is cheaper than any other commercial metal.

It is doubtful if any particular branch of the radio industry can claim to be the first to use aluminium for panels, chassis, and screens, but its present popularity for the construction of receivers is undoubtedly due to early experiments in short-wave work, and, as everyone knows, short waves were first proved to be of value by the amateur. Aluminium has from the early days of those experiments steadily increased in favour for the construction of all types of receivers, and although in some cases manufacturers are turning to steel, it is anticipated that they will return to aluminium, mainly owing to the unsuitable climatic conditions in England. It costs more to satisfactorily treat steel to prevent it rusting than to use untreated aluminium.

There are several commercial classes of aluminium obtainable by the amateur, but that sold for motor-car panels will be found most suitable for the simple tools the home constructor is likely to possess. This is usually "half hard" and can be easily handled without expensive tools.

## Cutting

The simplest and neatest way to cut aluminium is with a knife. This may seem rather controversial, but it is easily proved. With the knife long clean scores can be made. With a pair of shears, especially on long cuts, the edge will be misshapen and distorted, and generally curved, and some difficulty may be experienced in getting it flat again. Should this happen run the sheet through the ordinary household mangle several times, with the springs hard down. Large scissors or the garden shears can be used for short cuts. However, once the knife method is used, it will be always used. Sheets of practically any thickness can be cut easily and quickly. Lay the sheet on a clear, flat surface, and mark out the panel on both sides of the sheet with a rule and a scribe in the usual way. Then using the knife, which must have a thin and very sharp point, score the metal as deep as possible on both sides. If the knife has a tendency to stick just dip the point in a drop of paraffin oil to lubricate it. With sheets down to about 24 S.W.G. the scoring will usually be sufficient and the sheet will

part on being lifted. Thicker sheets require a few bends before they part. The edges of the sheet may be a little rough, but this can easily be smoothed off with a file. If the sheet can be satisfactorily supported in a vice, the edge can be planed with an ordinary carpenter's plane, but the face of the plane must be lubricated with oil, preferably paraffin, to prevent it sticking. Neither of the methods given above are suitable for brass or iron sheet.

## Drilling

Aluminium can be drilled very easily with any type of drill, but all have a tendency to raise burrs on both sides of the sheet. No satisfactory type of drill has yet been devised which gets over the difficulty fully, but an ordinary Morse drill, well cut back, and the edge very sharp and lubricated, is usually the best. Large holes are best cut with fine-toothed fret saws, or, if a bench drilling machine is available, a disc cutter can be employed. If a large number of holes have to be drilled or made in a sheet, such as a case for a mains eliminator where large holes are used for ventilation, it sometimes saves time to make a punch and

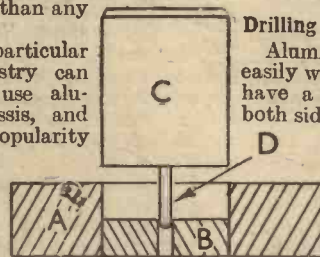

Fig. 1.—A punch and die for piercing holes in sheet-metal.

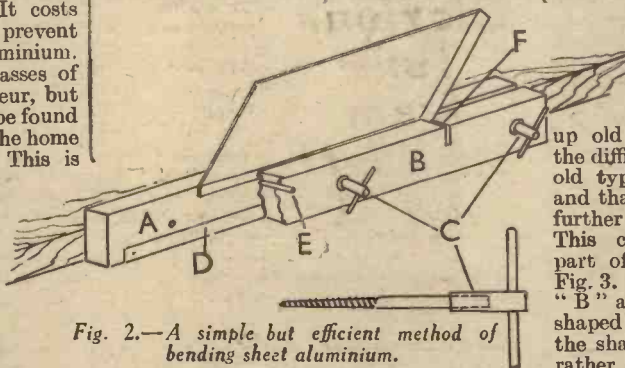

Fig. 2.—A simple but efficient method of bending sheet aluminium.

die to pierce the holes. Such a tool is shown in Fig. 1. "A" is any old piece of metal, preferably of steel, but brass will do, for quite a large number of holes if it is treated carefully. The inset piece "B" which is used for the guide pin "D" to locate in, may be of any material. The punch "C" should be of steel and has the pin driven into a hole drilled up the centre. The position of all the holes are first drilled roughly in the sheet the same size as that of the pin, and the tool is then assembled with the pin through the hole and squeezed up in a vice. Providing that the punch is a good fit into the hole in the die the resulting hole in the sheet will be clean and smooth. It will, of course, be necessary to remove the discs from the recess in the die

from time to time. Complicated shaped holes can, of course, be cut by this method, but the home constructor does not usually have any but round holes to cut, and the various methods by which this may be done will not be described. The principle, however, remains the same.

## Bending

The simplest manner of bending aluminium sheets is with the bender described by W. H. Deller in No. 5 issue of PRACTICAL WIRELESS. Another method which will also prove very satisfactory is shown in Fig. 2. The two jaws "A" and "B" are pieces of oak, the jaw "A" being permanently fixed to the edge of the bench. The front jaw "B" is clamped up by two, three or four large wood screws "C," fitted with pieces of tube through which are passed pieces of rod for easy turning. If a number of flanges have to be made of the same depth, two or more pins "E" may be passed through both jaws for locating the depth of the sheet before it is bent. The strip of material "D" is of the same thickness as that of the material to be bent, and helps to keep the jaws parallel. Slots "F" can be cut into the front jaw to allow a previous flange to pass into the jaw without damage, and also allows the next bend to be made quite flat.

## Forming

Aluminium is very ductile and can be formed into practically any shape without great difficulty. The home constructor, in using up old parts, will perhaps come across the difficulty that no allowance was made in old type condensers for very thin panels and that the spindle or the bush protrudes further through the panel than is desired. This can be overcome by sinking a part of the panel inwards, as shown in Fig. 3. Two pieces of hard wood "A" and "B" are turned up or can, of course, be shaped with ordinary wood tools to roughly the shape shown in Fig. 3. If the hole is rather deep it may be necessary to anneal the panel once or twice during the operation, and this can be done by heating that portion of the panel and plunging it into cold water. The metal should not be made red hot, but just sufficient to cause it to reject a drop of water placed on it.

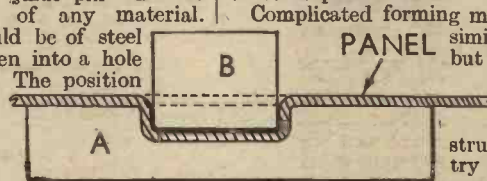

Fig. 3.—Method of sinking a panel.

Complicated forming may be done with similar tools of wood, but complicated jobs require a little practice, and the home constructor is advised to try out on a piece of waste material before attempting the finished job on a proper panel. The chief thing which must be guarded against is the loss of metal from the edges of the panel if deep and wide forms are proposed, Fig. 4, showing what happens in such a case. The original panel should therefore be cut much

larger than actually required so that it may be trimmed up after the form has been drawn. Edges of panels may be formed to a variety of shapes, and complicated mouldings can be produced quite easily by drawing along the edges a piece of hard wood slotted to the required shape.

#### Finishing

The sheet, when bought, usually has a fairly bright surface and, providing that it is not damaged when it is being worked, is suitable for use as it is. If a higher polish is required, this may be obtained with rouge and a very soft cloth. When a high polish has been obtained it is usual to

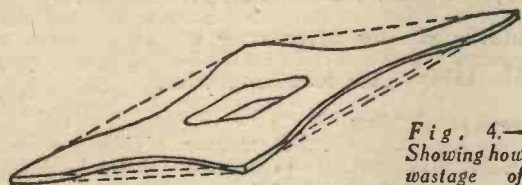

Fig. 4.—  
Showing how  
wastage of  
metal occurs round  
edges of panel.

give the surface a coat of thin, colourless lacquer. This should be applied with a very soft brush to a slightly warm panel, which is then placed upside down to prevent dust falling on the lacquer and thus spoiling the work.

The metal may be easily frosted with ordinary soda, although caustic soda will give a better and quicker effect. Make up a strong solution of either soda in a pail and boil. Place the panel into the boiling liquid until the surface is thoroughly frosted, withdraw and wash with plenty of hot water. Then rinse thoroughly in cold water to remove all traces of the soda. If the panel or other article is kept in the soda too long, black streaks will appear on the surface. The cure is, of course, obvious; they can be removed by rinsing in a weak solution of nitric acid, a 10 per cent. solution being suitable. Such an acid bath is a little beyond the scope of the home constructor, but the acid may be applied from a small vessel with a piece of rag. The acid must be thoroughly washed from the panel afterwards.

Fancy designs may be applied to the panel by applying suitably cut pieces of sticky paper to the panel in the required positions before the panel is inserted into the soda bath. These can be washed off afterwards, the portions of the panel underneath the paper still appearing bright against the surrounding frosted surface. You can if you wish make a stencil of your name in paper and so mark your receiver panels indelibly for all time. Or by applying a thin coat of wax, trimming the edge up with a knife to form an oblong panel, sign your name through the wax with a scriber, and so have your actual signature on the panel.

#### Satin Finish

Panels finished in this manner have a

very attractive appearance, but due to the fact that the scratches are tiny grooves, dust and dirt are likely to collect therein and the effect will not last long. Secure the panel to the bench with small screws and, using a stiff scratch brush, draw the brush along the panel in straight lines until the effect is obtained. If a fast revolving spindle is available the effect can be obtained very much more quickly, but only a light pressure is required or there will be the danger of dragging the surface of the metal, and a rough streaky appearance will result.

#### Engine Turned

This very fine finish for aluminium panels

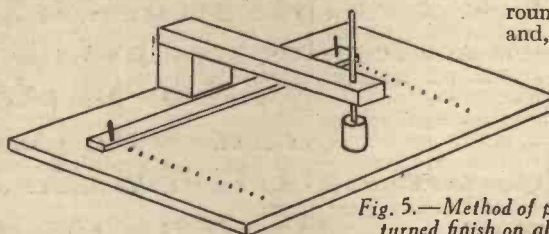

Fig. 5.—Method of producing an engine-turned finish on aluminium panels.

can be very easily obtained. The panel must first be brightly polished and then dusted over lightly with fine knife powder. A cork fitted to the end of a spindle is then fitted to a hand brace and the cork twisted over the panel. In order that the cork does not wander and each circle is clear and distinct, a wooden guide should be used (see Fig. 5), and if the circles are to be equally spaced, then a jig similar to the one shown in the figure, should be made. The bridge piece is drilled every  $\frac{1}{16}$  in. (for use with a lin. cork), for the vertical rows of circles and the pins drop into holes also spaced  $\frac{1}{16}$  in. apart for the lateral rows of holes. The unused knife powder should be blown off, or dusted off, with a very light brush and the surface treated with colourless lacquer.

#### Soldering Aluminium

No really satisfactory method of soft soldering aluminium has yet been devised to be as simple as the soldering of brass. The reason is due to the formation of a microscopic film of oxide which always forms on the surface of aluminium. Once this film can be removed and the air kept away, half the difficulty is overcome. As no suitable flux is available the only method is to clean the aluminium thoroughly and apply the hot solder to the heated metal. The metal should then be scraped through the molten solder with a scraper of some sort until some of the solder obtains a hold. Once this happens then a scratch brush may be used, still with the molten solder, to give a proper tinned surface. Once the surface has been tinned properly the job resolves itself into one of ordinary soldering. The joint, however, is not a very good one, and may part at some future date without warning, and it will not stand changes of temperature, as in the case of brass or copper soldering.

Two other methods are available, but these more nearly resemble brazing methods than soldering. They are, however, the only satisfactory ways of joining aluminium. The first of these two methods is known as the reaction method, and consists of a mixture of the solder and the flux. A chemical action takes place which dissolves the film of oxide and deposits direct on to the clean metal a thin layer of pure zinc which easily alloys with the aluminium. A blow pipe, or forced gas flame, is necessary to bring the metal to the proper temperature. The second method employs hard solder which has a melting temperature round about 550 degrees

and, therefore, a very hot flame is necessary. A special halide flux is employed which effectively dissolves the

oxide, and allows the solder to combine with the aluminium. Hard aluminium solders containing flux in the centre similar to resin cored solder can be purchased, and is really the only solution to a really satisfactory aluminium soldering job.

Actually the home constructor will find very little reason for soldering aluminium, and the simpler method of using nuts and bolts, or small brass eyelets, to join the separate parts of the chassis together will be found to be the most satisfactory in the end.

#### Earthing to Baseboards

The difficulty of obtaining a good solid connection to a thin baseboard screen by a wood screw passed through the screen, and so into the baseboard is obvious because of the tendency of the wood to shrink, and so release the screw. Matters are made worse if an attempt is made to solder a wire on to the head of the screw. A bolt may be passed through from the underside of the baseboard and secured with a nut on the top of the baseboard, but even this method is liable to lead to difficulties by the wood shrinking. A screw cannot be used direct on the screen because usually it is too thin to support the weight of the screw. The only method found to be satisfactory is to mark off the position of the screw hole, pass the screw up through the baseboard, and tighten up with a small nut which is drawn into the wood. Place a thin washer over the screw and place the baseboard foil in position. Place another nut over the screw and tighten it up to grip the screen, meanwhile the wood still supports the screw and prevents it moving, but does not affect the good electrical connection to the metal.

## SMOOTHING CONDENSERS

(Continued from page 534)

#### Working Voltage

An important point in the use of condensers is their working voltage. This depends upon the nature, thickness, and quality of the dielectric employed. If the applied voltage or electrical pressure is too high for the condenser, it will suffer

electrical breakdown, due to puncturing of the dielectric. This can be demonstrated in the case of the water analogy. If the spring which controls the plunger (b) is not sufficiently strong to withstand the water pressure, it will break down or flatten when the valve is suddenly closed, with the possibility of bursting the pipe or valve due to the momentum of the water creating a greater pressure at this point.

Condensers in an eliminator circuit have a cushioning effect, and this effect may be

increased up to a certain limit by increasing the capacity of the condensers. Beyond this point no advantage is gained by further increasing the capacity. Condensers may be connected in parallel or in series, the capacity obtained depending upon which method is used. When connected in parallel the resultant capacity will be the sum of their separate capacities, but if they are connected in series, they will act as a condenser having a lesser capacity than either of them individually.

# S.T.400

All keen constructors are now building the new 4-valve wonder set which gets over 100 stations. Amazingly selective—tested in all parts of the country.

Designed by the famous inventor,  
Mr. JOHN SCOTT-TAGGART, A.M.I.E.E., F.Inst.P.



Cabinet can be supplied separately without speaker at £2.

The Ready Radio Kit is absolutely complete down to the last screw, and includes panel (ready cut and drilled), baseboard, and Jiffilinx of the correct length for easy wiring.

## £4-17-6

Or by Easy Payments—deposit of 9/6 and 11 monthly payments of 9/9.

Ready Radio S.T.400 Kits are packed in special cellophane covered dust-proof cartons. Unless your Kit is packed in this special carton it is not a genuine Ready Radio S.T.400 Kit.

**MODEL "A."**

Complete Kit as above, with four specified valves and handsome walnut cabinet fitted with Permanent Magnet Moving-Coil Speaker.

£10-10-0

Or deposit of 20/- & 11 monthly payments of 21/-.

**MODEL "B."**

Complete Kit, with four specified valves.

£6-16-9

Or deposit of 12/6 & 11 monthly payments of 13/9.

Build your S.T.400 with the Authorised Ready Radio Kit approved by Mr. John Scott-Taggart, A.M.I.E.E., F.Inst.P., who writes:—

"With reference to my S.T.400 Receiver, described in the current issue of 'The Wireless Constructor,' I have received for test from Messrs. Ready Radio, Ltd., a kit of parts in accordance with the circuit. This kit has been tested and has proved entirely satisfactory."

**FREE WITH EVERY KIT.** Full size blueprint and full size photoplans with easy-build wiring chart and copy of "Wireless Constructor," containing full instructions. **EVERY COMPONENT EXACTLY FITS THE BLUEPRINT.**

**READY RADIO "303"**  
Five Wires Only to Connect!  
The 3-valve set you can build in twenty minutes.  
**47'3**  
with full instructions

**READY RADIO METEOR S.G.3**  
All-world, All-wave Radio!  
The all-wave version of the famous S.T.300  
**£3-15-3**  
with full instructions

**READY RADIO S.T.400 REBUILDER'S KIT**  
for all S.T.300 owners  
**35/-**  
Everything necessary to convert your S.T.300 to the correct S.T.400, with full instructions and blueprint.

# READY RADIO

Ready Radio Kits are stocked by all leading radio dealers. If any difficulty—order direct.

Telephone :  
Lee Green 5678.

**READY RADIO, LTD.,**  
Eastnor House, Blackheath, S.E.3.

Telegrams :  
Readirad,  
Blackvil, London.





# TELSEN L.F. TRANSFORMERS

## COUPLING UNITS and OUTPUT CHOKES

### TELSEN "ACE" L.F. TRANSFORMER

The Telsen "Ace" is eminently suitable for Receivers where highest efficiency is required at low cost and where space is limited. Its characteristic curve bears comparison with that of the most costly transformers  
Ratio 3-1 **5/6**  
Ratio 5-1

### TELSEN "RADIOGRAND" (Ratio 1.75-1) TRANSFORMER

For use in high-class receivers employing two stages of L.F. amplification. When used following an L.F. stage employing choke or resistance coupling, it gives ample volume with remarkable reproduction. **10/6**

### TELSEN "RADIOGRAND" (Ratio 7-1) TRANSFORMER

Gives extra high amplification on receivers employing only one stage of L.F. amplification. Not recommended for use with two L.F. stages, as overloading is likely to occur. **10/6**

### TELSEN 1-1 INTERVALVE COUPLING UNIT

A modern development of the R.C. unit, incorporating a low pass filter feed in its anode circuit, thus preventing instability due to common couplings in eliminator and battery circuits. Used with an H.L. type valve it gives an amplification of about 20 and a perfect frequency response on a negligible consumption of H.T. current. Its remarkable "straight line" characteristic curve places it in the forefront of all components of its type. **7/6**

### TELSEN INTERVALVE L.F. COUPLING CHOKES

Primarily designed for use as coupling chokes but may be used in any circuit carrying not more than the stipulated maximum current. The 100H type is for H. or H.L. type valves and the 40H for L. types.

Normal	Max.
Rating Current	Current
40H—5 m.a.	10 m.a.
100H—3 m.a.	8 m.a.

**5/-**

### TELSEN TAPPED PENTODE OUTPUT CHOKES

For mains and battery operated pentodes taking an anode current of up to 20 m.a. The single tapping provides (by reversing) ratios of 1-1, 1.6-1, 2.5-1, ensuring perfect matching under widely varying conditions. Also suitable for matching a low impedance speaker with an ordinary power valve, a 1 mfd. coupling condenser being recommended for this purpose. **7/6**

### TELSEN OUTPUT CHOKES

Designed for use with power or super-power valves taking an anode current of up to 40 m.a., this output filter provides an ideal response curve under all conditions. For use with a condenser of not less than 1 mfd. capacity. **7/-**

### TELSEN POWER PENTODE OUTPUT CHOKES

For mains operated pentodes taking an anode current of up to 40 m.a. Serves both to prevent direct current passing through the speaker and to match the speaker to the pentode valve, with the choice of three ratios—1-1, 1.3-1, 1.7-1. Used with a 1 mfd. condenser it gives a great increase both in quality and volume. **10/6**

### TELSEN MULTI-RATIO OUTPUT TRANSFORMER

For use with moving-coil speakers, having a low impedance speech coil winding, and suitable for anode currents of up to 40 m.a. Three ratios—9-1, 15-1, 22.5-1—allow for correct matching of speakers of widely varying characteristics. **10/6**

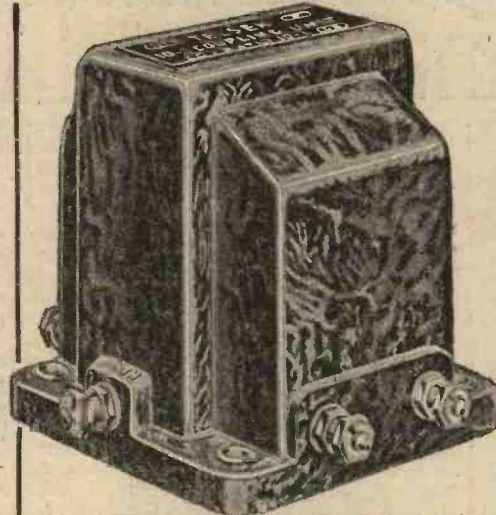

### TELSEN RADIOGRAND (Ratio 5-1) L.F. TRANSFORMER

Telsen Radiogrand Transformers have signified to expert designer and enthusiastic constructor alike all that is finest in British Radio craftsmanship. They are designed in accordance with recent research, constructed on the soundest engineering principles and tested rigorously under broadcast conditions for immaculate performance and enduring efficiency. The excellence of the characteristic curve is only the logical result of this insistence on perfection, revealing the fact that they

give a performance equal to that of the highest priced transformers:  
Ratio 3-1  
Ratio 5-1

**7/6**

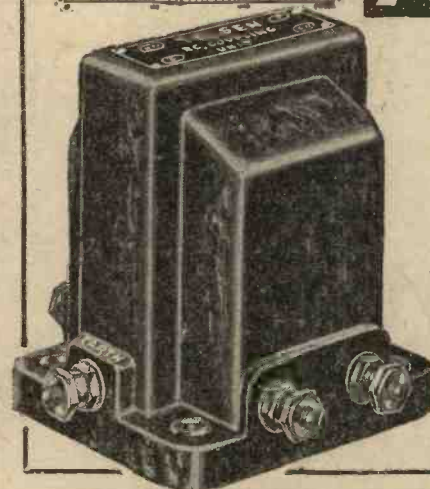
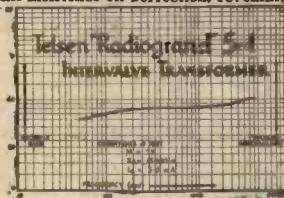

### TELSEN OUTPUT TRANSFORMER (Ratio 1-1)

For connecting the speaker to the output stage, using a triode valve. Avoids saturation by isolating the D.C. from the speaker windings. Also keeps H.T. voltage from the speaker and its lead, which is specially important where a D.C. eliminator is being used. Suitable for anode currents of up to 40 m.a. **10/6**

**TELSEN 10-1 INTERVALVE COUPLING UNIT**  
A filter-fed transformer using a high permeability nickel alloy core, securing a 10-1 voltage step-up while preserving an exceptionally good frequency characteristic. The response is compensated in the higher frequencies for use with a pentode valve giving an amplification greater than anything previously achieved, equal to two ordinary L.F. stages but with better quality of reproduction.

**12/6**

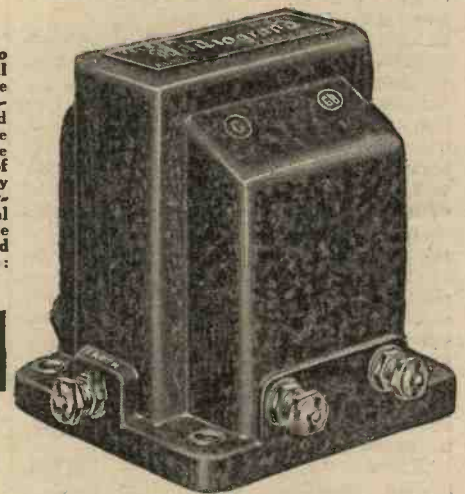
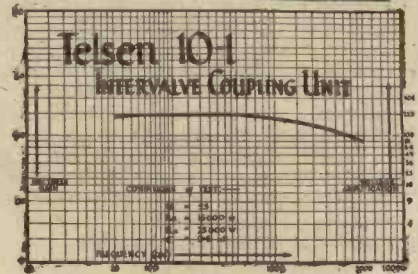

### TELSEN R.C. COUPLING UNIT.

A complete assembly in a compact and convenient form for effecting Resistance Capacity Coupling in the L.F. stages of a receiver, conforming in design to the Telsen L.F. Transformers and Chokes. The Unit incorporates a 50,000 ohms wire wound anode feed resistance and a .01 mfd. coupling condenser. For best results it should be preceded by an H.L. type of valve having an impedance of approximately between 10,000 and 30,000 ohms, and be connected to an H.T. supply of not less than 80 volts.

**4/-**

# TELSEN

**RADIO COMPONENTS**

**TELSEN RADIO COMPONENTS ARE 100% BRITISH**  
ANNOUNCEMENT OF THE TELSEN ELECTRIC CO., LTD., ASTON, BIRMINGHAM



# Radio Ramblings

JOTTINGS FROM MY  
NOTEBOOK.

By "DETECTOR."

## Co-operation of N.P.L. and U.S.A. Bureau of Standards

THE Reports on the work done by the National Physical Laboratories issued from time to time invariably contain something of absorbing interest to radio experimenters. The latest gives details of a useful co-operation between our own N.P.L. and the Bureau of Standards, the U.S.A. equivalent. The international adoption of standards of current and voltage has made the way of manufacturers of electrical apparatus of all kinds much easier, but there are still many radio and electrical units of measurement that possess varying values in different countries. It is hoped that by even closer co-operation these units will be brought more closely in line. An example of this work that is continually going on was cited in the case of a mica condenser of standard capacity. This condenser was transported between the N.P.L. and the American Bureau of Standards no less than four times and some seven sets of measurements of its capacitance were made. During the first transportation a change in capacity was noted although no subsequent changes of important magnitude were noted, that is, after due allowance for certain factors giving incorrect readings were made. An interesting fact is that the difference in capacity due to the difference in altitudes of the two stations was found to be about 0.2 parts in ten thousand. Not much, you may say, but quite a large amount to our modern physicists. Of course, it is a remarkable thing that the change of capacity due to barometric height should be noticeable at all, and while at the present this fact may not be of material importance to radio men, who knows what bearing it may have on future developments? A résumé of the measurements showed that while due allowance was made for the atmospheric variation of the two countries, the final result of the measurements made agreed to within one-hundredth of 1 per cent.

## Radio Advertisers' Technicalities

I HAVE a friend who is engaged in the advertising profession, and the other day he complained that as a class, radio advertisers were much too technical. Not unnaturally, I took up the defensive, but my defence was not so spirited when I found he excluded practical radio papers from his remarks. These, he stated, catered for a circle of readers who already knew what the manufacturers were talking about, when they spilt a lot of "copy" about such random technicalities as bias, inductance, screened grid, capacity and

so on. It was the set-maker, he said, whose object was the attracting of new customers and of new listeners to the lure of wireless, who were the worst offenders. "Does the average man in the street know what a 'moving-coil' is?" he asked me point-blank, and I had to confess that there were probably a large number of people who didn't. He went on at some length in the same strain and said that a man about to possess a wireless set rarely cared how many valves it had, he didn't give a hoot whether it had a "screened grid," a "band pass" or a "moving" or "fixed" "coil" (he seemed to think of the latter as some sort of tuning arrangement) so long as the set would get stations at comfortable volume. That there is some justification for this opinion I am quite ready to admit, for after all, new listeners are not likely to be obtained if a formidable mass of technical matter has to be digested before choosing a set, and the idea that this is a *sine qua non* is still very prevalent among "on-the-brink" set buyers. What do you think about it? Do you agree that our set manufacturers should deal more with the delights of radio rather than with a detailed specification of the "works"?

## How Beginners are Mystified

THEN we come to the beginner in wireless. The amateur of to-day

who will become the serious experimenter of to-morrow, and who is being catered for by our Beginner's Supplement, is still often completely mystified by technical allusions and abbreviations that many advertisers use. For years our valves have been known by a series of code letters or logarithms and now most of our loud-speaker makers call their models by a series of letters and numbers. All this makes the description of a wireless set read like a chemical formula and must put a good many people off altogether, and this incidentally reminds me of a good story I saw the other day. A yokel "up from the country" stood outside a large radio store in the West End until a policeman came along. "Would you mind going in there for a catalogue, please?" asked "Garge" of the Bobby. When the policeman recovered, and demanded an explanation, the yokel pulled out a newspaper advertisement and pointed to a sentence which read "Send P.C. for catalogue"!

## Ringin' Up for the Right Time

TELEPHONE subscribers in Paris and other parts of France will soon be able to hear the time by just ringin' up their local exchange and merely listening. An electrical clock has been installed at the Paris Observatory which announces through a loud-speaker in a clear voice the hour, minute and second *every ten seconds*. Will we ever come to the end of the uses to which valves may be put? I think not!

## Mercury Arc Rectifier

ONE of the most outstanding developments in electrical progress is that of the mercury arc rectifier. At present this device is only applicable to large users of electricity, but its great feature is that it will work *both ways*. That is, A.C. can be turned into D.C., or D.C. can be turned into A.C. at will. When you think this out you will see that by the use of this type of rectifier it is possible to use storage batteries delivering direct current as a stand-by for alternating current apparatus. Again, electric railways can be so modified that the electric locomotives can run over long stretches of line of varying current conditions and run on A.C. or D.C., whichever is available. In our own field, if the system could be adapted for home use, listeners on D.C. would be able to enjoy the manifold advantages of A.C. sets and valves.

## Electric Clocks Operating from A.C. Mains

THE manufacturers of those interesting electric clocks that operate from A.C. mains

## THE P.M.G.'s. CAMPAIGN



As a development of lessons in metal and woodcraft, Ivydale Road, Nunhead, L.C.C. schoolboys have made and constructed a telephone apparatus, which has included the making of all coils, mouthpieces and receivers, etc. This provides a wide field of scientific teaching of the kind that appeals to all boys. A proper series of exercises, based upon practical experience and following in the P.O. Telephone Directory, has been drawn up. Incidentally they exercise their self-confidence and their speech is receiving careful training. The girls are very enthusiastic, having been allowed to use the apparatus. The illustration shows some of the children receiving dictation over the telephone, which is "transmitted" from the headquarters room.

and use the periodicity as a means of telling the time, have been having a conference to further the sale of these clocks, and to devise further schemes to popularise them. One of the biggest drawbacks to them is the need for a length of wire to connect them up to the mains, and modern housewives are not particularly enamoured with long trailing leads, whatever their menfolk may think. Moreover, our conservative builders are not over generous with lighting and heating points in the average house, so that either a new point has to be fitted near the clock or the above mentioned length of flex has to be used. It is a good idea to keep such a clock on the wireless cabinet, and I have seen one of them used in the centre of a loud-speaker fret. Care must be taken to avoid interference with the set, however, and, if necessary, metal sheathed wire should be used to connect up to the clock mechanism. At the makers' conference it was decided to approach those power stations who are not too particular over the periodicity of their supply, to come in line and instal a definite control over this. There are not many stations of this type, however, as practically all power stations are most particular that their supply shall be steady and correct to voltage and frequency.

#### Old and New Sets : A Comparison

I RELATED some time ago how I went to an exhibition of old wireless apparatus. Well, I attended another of the same type the other day, but in this one there were many more old sets made by amateurs from published designs. I was immediately struck by the way in which our modern sets have shrunk in size and layout. It cannot be said that our components have altered in size much, for with the exception of some midget L.F. transformers, most of the modern components remain much about the same as regards cubic capacity. In fact some of the ganged condensers are much more bulky though, of course, the use of ganging cuts out the need for large panels. Some of the sets I saw were well over two feet in length, and many of you remember the "straight eight" commercial set that had half-a-dozen or so variable condensers that required manipulating. Verily, those days were a paradise for makers of ebonite. Nowadays, of course, we crowd our components up to an extent that would have shocked an old-timer, and the use of screening has assisted this. Still, in those days, we used to get a station about every ten degrees, whereas now we get one, and sometimes more, in a decimal of that amount. Externally I should think it is our tuning coils that have changed the most, although an old variable condenser is a strange sight when compared with a modern one. On the other hand the L.F. transformers of to-day look much the same as their predecessors of ten years ago, even though they may be smaller, and rather more handsome in appearance. With these components, however, it is the "innards" that have been radically altered, as substitution of an old type component will quickly prove to you. Another feature of the old sets that struck me was that it was considered unforgivable if even just one valve deviated in position from the straight line arrangement that was then *de rigueur*. Our valves could be viewed like lamp posts down a street, and were just as accurately placed. Now we put them where they work best, and who could wish for more?

## RADIO of a DIFFERENT KIND

By C. DANVERS WALKER

THERE is not a country in the world to-day that has not got its own radio station, and each and every one proudly boasts of its capabilities, yet underneath their individual pride there is, if not an open admission, an envious realization that England has the most perfect wireless system that has yet been conceived. In fact, it is no disgrace to admit that several national stations use the B.B.C. as a model on which to formulate their service. But as broadcasting is a thing that has no "reception" barriers, and may be heard by whoever chooses, it seems to follow that the stations concerned may also learn a lot from "the other man's point of view." Overlooking for the time being the conditions under which wireless operates in, say, America, which lives on advertising, or Australia, where you have a combination of the two principles (advertising and non-advertising), there are several methods of programme presentation that might well be considered.

#### Radio Competitions

I take advantage of some of the sponsored sessions used in conjunction with competitions organised by several Australian business houses. A well-known firm with a world-wide reputation once utilized the sound-effects studio with wonderful results during the period of their competition. The idea was this:—

Everybody knows that a sound-effects department gives valuable atmosphere to a radio play, but very few know just how those "noises" are made; so a competition was arranged whereby several of the instruments and props were operated so as to broadcast their individual sounds. The listener was then asked to write down his interpretation of each, and also give his idea as to how the sound was made. For instance, when you hear the sound of an aeroplane issuing from your loud-speaker, it does not necessarily mean that an Imperial Airways four-engined plane has been parked in a corner of the studio; actually this realistic effect is produced with an electric fan with a piece of stiff paper held against the revolving blades. The competition was a great success, and many and varied were the solutions sent in. I remember seeing one entry from an obviously dear old lady, who thought that the sound of machine-gun fire was obtained by "clicking the tongue and snapping the fingers together." When this suggestion was shown to the sound-effects man he didn't seem to like the idea at all.

Another contest, run on similar lines, made use of "everyday sounds," such as the ticking of a clock, chopping wood and a motor-car engine running. In this instance the genuine article was used, and it was interesting to see the many results that were sent in with such conflicting answers. Apart from the competitive side of this experiment, it was quite a useful means of confirming the recognized fact that the use of the genuine article does not necessarily reproduce such true sounds as will an artificial medium. Competitions for the best broadcasting voice have been fairly frequent, and incidentally brought to light some quite useful material. But more often than not the building has been filled

with highly-strung sopranos and bathroom tenors, but all the same a novel and, therefore, successful means of attracting public interest in a sponsored session. Even if the listener likened the voice to a cross-cut saw he, at least, got an amusing thirty minutes.

#### Instructive and Amusing

Surprise items always make an appeal, and it is when the microphone is taken in to unusual surroundings that an everlasting impression is made on a firm's potential customer. Take the example of the diver who broadcast his experiences from the river bed. It was really rather funny. The plan was to send down two men in costume and then get them to hold an under-water conversation.

One man was an expert diver and the other just an ordinary individual who was to ply the diver with questions. Before the transmission came off, the amateur was given full instructions how to control his air-regulating apparatus, and when zero hour came both men were lowered down. The first few minutes of the conversation were quite successful, but they had not been down very long before weird noises were heard coming through the monitoring control-man's headphones. It appears that in the excitement of the occasion the novice got confused with the controls on his suit, with the result that it became inflated like a full moon and began to float upside down to the surface.

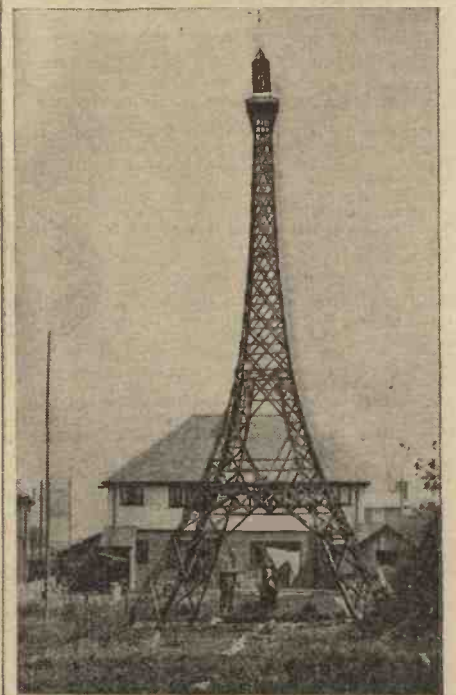

MODEL OF EIFFEL TOWER AS A WIRELESS AERIAL

Mr. Bernard G. Warr, of Solihull, has constructed a model of the famous Eiffel Tower, which he is now using in his garden as a wireless aerial mast. The structure is 40ft. in height and is made entirely of wood without guy-wires.

COMMENTS ON COMPONENTS



# What we Found..

**ELECTROLYTIC CONDENSERS**

THE Dublier Company are now manufacturing electrolytic condensers of the dry variety, and these are obtainable in a number of different capacities. These consist of a cylindrical aluminium casing, less than two inches in diameter and about four inches long. The positive element is brought out to one end of the condenser and centred in a 1/16 in. ebonite thread, and is provided with a large soldering tag. A large lock-nut and spring washer are provided on the ebonite thread, and this enables the condenser to be mounted in a very convenient manner on receivers of the all-metal chassis type. A 1/16 in. hole is drilled through the chassis and the ebonite thread passed through. This brings the edge of the case into contact with the surface of the chassis and so provides the negative connection to the condenser. (This chassis of a receiver is always joined to the H.T.—supply.) The advantages of this type of condenser are simplicity of mounting, much smaller compass, and greater smoothing properties. For smoothing the output of a mains eliminator this is the best type of condenser to employ. The 4 mfd. type costs 4s. 6d., and the 8 mfd. type costs 6s. 6d.

**THE AUTOCEPTOR**

A SIMPLE means of rapidly switching the receiver to the local station would often prove useful in a set which is used by different members of the family. The Autoceptor, a component produced by Messrs. A. W. Hambling, Ltd., is an ingenious device which may be attached to any existing receiver, either internally or externally. The device consists of two pre-set condensers, and a change-over switch, moulded into one casing, which is drilled to enable it to be screwed in any position. In addition the switch is fitted with a one-hole fixing screw, in case this method of mounting is preferred. Two terminals, marked G and E, are joined to the grid and earth terminals of the receiver. With the switch in the centre position the ordinary condenser in the receiver may be employed for tuning, and the Autoceptor is inoperative. When pushed to right or left, one or other of the small condensers is brought into circuit, and may be used for tuning. When these are adjusted to the locals, therefore, a touch of the switch will bring the Autoceptor condensers into circuit and so enable the local to be heard at once. The price of this selector is 6s.

**THE "CLIX" MASTER PLUG**

"It's the little things that matter," says the proverb, and this is very true in radio. Just a "wander plug." Almost an unconsidered trifle in the serious business of constructing your set. Yet much depends on it. The H.T. current to all valves has two wander plugs in its circuit. The frequently poor contact of the ordinary plug means serious loss of efficiency in many ways. This new Clix pattern is really a self-adjusting banana, or wander-plug, which automatically adjusts itself to a considerable variation of socket diameter, and gives metal to metal contact. It has a large contact area, its prongs enter easily, and its "set" is permanent. So many plugs seem to be made of lead, and collapse the first time they are used, causing crackling noises, variation of volume, and irregular reaction. Costing 1 1/2d. each, coloured black or red, and with a full range of markings, Clix are certainly worth while.



The Clix plug, showing the well-sprung contact points—the most important feature of a wander plug

accurate "one-knob" control, it is also desirable to have a matched oscillator coil. The Igranle set of coils comprises three I.F. coils and a three-band oscillator. This covers a band of 19 to 32 metres; 190 to 600 metres, and 500 to 2,100 metres. The I.F. coils are fitted with four-pin bases, spaced to fit ordinary valve-holders, and a screened pig-tail for S.G. valve anode connection. The oscillator has a self-contained three-way switch, and is one-hole fixing. The price of the set is 35s.

**PLATELESS ACCUMULATOR**

THE name of Fuller has for years been associated with the block type of accumulator, and now, from the firm of this name, comes a further innovation in these cells. It is a plateless accumulator, which is lighter, smaller, and lasts twice as long per charge, as the ordinary type of wet cell. In addition, it is

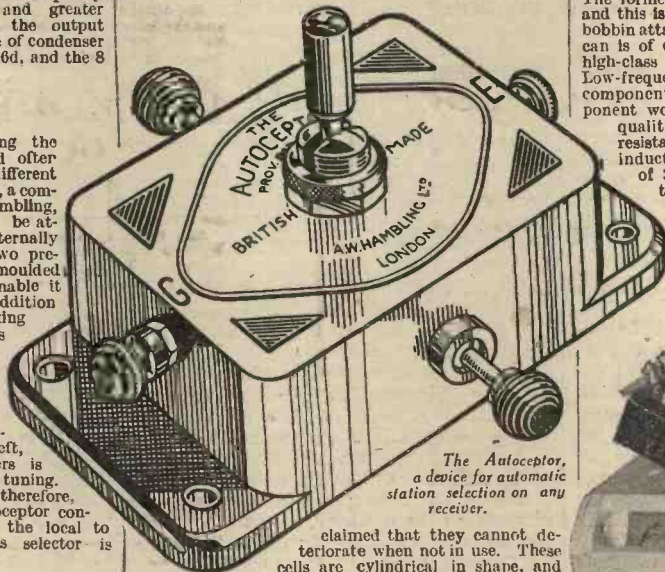

The Autoceptor, a device for automatic station selection on any receiver.

claimed that they cannot deteriorate when not in use. These cells are cylindrical in shape, and have a central positive conductor (lead) surrounded by a positive active material. Round this latter is a glass wool separator, and this entire assembly is contained in a perforated ebonite container. The shell of the complete battery consists of a lead cylinder, with a bakelite outer surface, and this cylinder forms the negative plate. An active negative material is in contact with the plate, and the assembly mentioned above stands inside this latter assembly. The small space left between the two parts is filled with acid. Owing to this circular construction, the current is forced to pass evenly and uniformly from centre electrode to outer electrode, and this results in double the capacity for a given area, and a constant discharge rate. The bakelite case may be obtained in any colour, to suit individual requirements, and the price of the 2v. 80 amp. types is 11s. 6d.

**THE MILNER H.T. UNIT**

H.T. batteries are heavy, and also expensive. In certain districts in the country, it is also a trouble to carry a weighty battery from the nearest town or village. The new type of wet H.T. battery bearing the above name is a very useful article for the listener who requires an unfailing H.T. supply, and has not

**SUPER-HET COILS**

TO construct an efficient super-het. receiver, carefully-matched coils are essential. The intermediate frequency coils must each be individually matched for not only the particular frequency chosen, but in conjunction with the other I.F. coils. To ensure

access to the electric mains supply. This unit consists of nickel iron cells, which are kept automatically fed from the low-tension accumulator. A wooden case is divided into partitions, and a number of small glass tubes are held in the divisions so formed. The tubes contain "Alkum" nickel and steel plates, immersed in a steel-preserving alkaline solution. The connections are taken to a series-parallel switch, and in use the cells are connected in series, and for charging, they are joined in groups of four each, by a simple movement of the switch. The accumulator is then used for charging the cells, and as this is only a matter of milliamps, there is no undue strain on the I.T. battery, and as soon as the H.T. cells are charged, the action ceases. In this manner there can be no damaging of either battery. A 90-volt unit costs £2-18-0, and a 150-volt unit, £4-14-0.

**LEWCOS H.F. ALL-WAVE CHOKE**

THIS is a new design in H.F. chokes, and is designed for all wavelengths from 15 to 2,000 metres. In place of the usual small article, this component is enclosed in a metal can, 2 1/2 in. by 4 in. For connection, the base is fitted with four valve-pins of the standard pattern, and the can is connected to a filament-pin, which is for earthing in the same manner as the metalised valves. The same pin is employed. The actual winding is contained on an eight-ribbed ebonite former, 1 1/2 in. in diameter. Very fine enamelled wire is used for the winding, and this is spaced about 40 to the inch. The former is employed for the short-wave winding, and this is joined to a long winding carried on a small bobbin attached to the top of the former. The shielding can is of copper and, therefore, this component is a high-class article. The price is 6s. 6d. The Lewcos Low-frequency Choke, Type 34, is also an interesting component, built on substantial lines. This component weighs over 2 1/2 lbs., so that some idea of the quality of the article may be judged. The D.C. resistance of the winding is 570 ohms, but the inductance is 30 henries, with a limiting current of 30 m.A. A centre-tap is brought out to a terminal on the side opposite to the normal two terminals, and this will be found a very useful adjunct. The price of this component is 12s. 6d.



The W.B. loud-speaker which was referred to on this page last week. A full test report will be given at a later date

# SUPER SELECTIVITY

with the

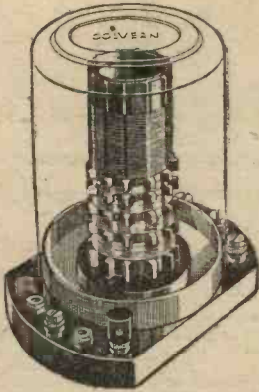

## COLVERN T.D. COIL

**T**HE Colvern T.D. Coil is completely screened and incorporates tapped aerial coupling and reaction.

Four alternative aerial tappings are arranged as sockets with a wander plug.

The first two tappings give aerial couplings similar to those normally employed but with greatly increased selectivity.

Numbers 4 and 5 give a high degree of selectivity with weak aerial coupling suitable for use in a swamp area. There is no break through on the long wave-band from B.B.C.

stations.

Suitable for detector L.F. type or screen grid receivers.

**PRICE**  
**8/6**

Send for the Colvern  
circuit booklet, RL10.

# COLVERN LIMITED

MAWNEYS RD., ROMFORD,  
ESSEX.

# NEW

## GAMES AND TRICKS FOR CHRISTMAS!

New games are always enjoyed. New tricks are always appreciated. Here are a few books explaining many really new games and tricks with which you can give your friends a merry Christmas.

### CARD GAMES

And How to Play Them.

By PETER ALSTON.

Stiff boards. Price 2s. net, post free 2s. 3d.

A Guide to all the popular games played to-day. Whist—Solo, Auction and Progressive—Bridge, including Royal Auction and Contract—Baccarat—Bezique—Cribbage—"Nap"—Poker—Fiquet—Vingt-et-Un—Patience Games, etc., etc.

### BROADCAST CONJURING TRICKS

By CYRIL SHIELDS,

The well-known wireless magician.

Price 2s, post free 2s. 4d.

Mr. Shields dedicates his hooks to his many friends and the hundreds of children who wrote to him when he was giving lessons in Simple Conjuring Tricks during the children's hour.

### 100 MORE TRICKS YOU CAN DO

By HOWARD THURSTON,

America's Leading Conjuror.

Bound in Cloth, Price 2s. net, post free 2s. 3d.

Any trick is easy when you know how it's done. With the aid of this book you can mystify your friends with Card Tricks, Coin Tricks, Match Tricks, Handkerchief Tricks, etc., as easily as a professional conjurer.

### CARD TRICKS

By L. WIDDOP.

Stiff Boards. Price 2s. net, post free 2s. 3d.

A Volume which will give the Amateur or Semi-Professional, who does not wish to spend a great deal of time in practice, material for entertaining performances. Card Tricks presented in new forms and with up-to-date patter.

### THE BEST TRICKS AND HOW TO DO THEM

By DAVID DEVANT,

The Well-known Conjuror.

Price 2s. net, post free 2s. 4d.

The contents include Coin Tricks, Tricks with Balls; Card Tricks, Feats of Memory, etc., etc.

### MATCH STICK MAGIC

By WILL BLYTH, M.I.M.C.

With a Foreword by David Devant.

Illustrated by 160 Diagrams

Stiff Boards. Price 2s. net, post free 2s. 3d.

Being a Collection of Entertaining, Amusing and Instructive Puzzles, Games, Scientific and Constructional Experiments, Conjuring Tricks, etc., to perform which only a few matchsticks are required.

May be had of all booksellers or for Post Free prices direct from the Book Publisher, PEARSON'S Book Dept., 18, Henrietta Street, London, W.C.2. Full list on application.



# Practical Letters

from

# Readers.

The Editor does not necessarily agree with opinions expressed by his correspondents

### Thanks!

SIR,—I am now reading the eighth issue of your book PRACTICAL WIRELESS, and I think it is time to thank you for bringing out such a splendid book. I never miss a week without having it and everyone of my wireless friends gets it every week. Your articles are so nicely and simply written that it is the greatest of pleasure to read them. And one good thing is that you do not give us a new circuit every week, which is about the most boring thing a wireless journal can do. Wishing you all success in the future.—MARTIN HOGAN (Dublin).

### Polarity Testing

SIR,—I was interested in your articles on above in your No. 8 issue, and should say that a lamp in series would have been more practicable, leads being brought close together (or touched) without fuse trouble. Considering your excellent articles—the omission struck me. In regard to Mr. Richardson's statements, amateur "fuses" are the cause of a great deal of his trouble. Now speaking of gas-pipe earths (with me—taboo for preference), this also applies to general electrical rules, as considered dangerous, particularly if any heavy leakage takes place, due to breakdown in apparatus so earthed, or remote possibility of lightning directly striking an aerial thus earthed. Anyhow, if a lead water-pipe suffering from "Electrolysis" is not the best earth, why do some supply systems use this method of earthing apparatus? Pass the bread and fluxite, Mr. Editor, and here's good luck to the best paper I have read yet.—G. E. METCALFE (Newport, Mon.)

### Prices Wanted

SIR,—As you welcome suggestions from readers, I would very much like to put forward two of my own. Here they are.

Firstly, when publishing details of a new set, it would be very desirable if you gave the current price of each component, in order that your readers can tell at a glance the total outlay incurred. As it is, unless one is familiar with them (and I very much doubt if the majority of your readers are), it means tediously hunting through numerous catalogues finding the various prices, or else asking a radio dealer to supply you with them, only to find that the price is quite beyond the range of one's pocket.

My second suggestion is that, judging from the correspondence received and published by you, a vast number of readers are newcomers to wireless construction

who would no doubt greatly appreciate the publication of two or three simple two-valve circuits on which to test the knowledge they have acquired since reading PRACTICAL WIRELESS, and these circuits would have the added advantage of being less costly for experimental purpose than those published hitherto.

Being a "rabbit" myself, I would greatly appreciate these innovations, and I am quite certain that many other readers would do also.—S. V. COLEMAN (Surbiton).

[On practically every occasion that a new set is described in our pages, one of the Mail Order houses will be found to display an advert. setting out the prices of components, or complete kits.—Ed.]

### From a Headmaster

SIR,—Very many thanks for your letter. PRACTICAL WIRELESS is now the most perfect wireless magazine yet published. It is a delight to beginner and expert alike. Again I thank you. I'm taking your Beginners' Articles with the boys at school. They love them.—A. W. DAVIES (Whitchurch).

### One For Mr. Richardson

SIR,—After having read wireless weeklies until "choke fed" with the wonders done in laboratories to produce the "unworkable one" "two," "three," etc., *ad nauseam*, I greet your issue as a long-felt want, and each issue proves that you have come not only to stay, but to impart knowledge in an easily assimilated form, for which many thanks. Now I want to suggest—not grumble—that you do not drop into the bad habit of so many publications, of giving information which, though valuable in

CUT THIS OUT EACH WEEK

## DO YOU KNOW?

—That a resistance of small value—say 50 to 200 ohms, inserted in the anode circuit of L.F. valves prevents H.F. oscillation.

—That two ordinary valves (of the L.F. or small-power type) may be used as half-wave rectifiers in an eliminator to produce full-wave rectification.

—That the priming-grid of a pentode valve is the one which is joined to the extra terminal or valve leg.

—That the anode of a screen grid valve is not joined to the normal anode pin, but to the cap of the valve.

—That the stopper of an accumulator should always be removed whilst the cell is being recharged.

—That a soft valve breaks down due to bombardment of the filament by positive ions.

—That there are only seven metals which will emit electrons when acted upon by light.

—That the thirty holes used by the Baird system of television is now universally recognized as the most suitable number.

general, is rendered useless in particular cases by the omission of perhaps one little detail; for instance, on page 376 of November 12th issue, Mr. Richardson's fine article, loses a *little* of its value (to me), when he says: "For the same reason, the by-pass condenser just mentioned should not be larger than necessary," and no value of condensers is suggested as a trial point.

Then on page 390, at foot of first column: "Then join a *large* fixed condenser, etc." What is a large one—I mfd. or 8 mfd.? Again, a reader—in third column—says: "Add a resistance in series with the 4-volt winding, etc." What value? And what is his idea of a "sufficient quantity" of wire? Don't think me hypercritical, one does not expect all lean meat and no bone; yours is a veritable mine of useful reading, confined, I am glad to note, to Practical Wireless, not a conglomeration of "Sets," "Funniosities," Gramophone, Talkies, Television and programme criticisms. More power to your elbow!—"MOBBY," West-cliff.

### From South Africa

SIR,—I called in at my newsagent this afternoon and looking around for wireless books discovered PRACTICAL WIRELESS. I said, "What, PRACTICAL WIRELESS?" and received the reply, "Yes, something new." As it was the only copy in stock I purchased it and also booked at once for a weekly copy.

Upon this "something new" I, as a South African amateur, wish to congratulate your staff and all concerned on this very fine publication. It is just the thing I have been looking for, for a very long time—something practical. As our English mail arrives on Wednesdays, I am already looking forward to Vol. 1, No. 2, which comes to-morrow.

I don't know whether you would accept any suggestion from a South African, but nevertheless—here it is (or they are).

As I am a transmitting member or amateur, I think other amateurs, like myself, would like to see something about transmission—not commercial, but amateur—and also perhaps something on television.

Re pages 56 and 57 of Vol. 1, No. 1, how does this apply to readers in far-off countries?—K. M. J. RADUE (Kingwilliams-town).

### Testing Polarity of the Mains

SIR,—I note your reply in this week's PRACTICAL WIRELESS to my letter in respect of finding the polarity of mains, and I do not agree that it is just as easy to short-circuit the mains when connecting up a home-made eliminator or mains-operated receiver. Such apparatus can be tested before use and can be connected up with

the switch off, whilst it is necessary to have the switch on in order to test for polarity, unless some arrangement is made to keep the wires apart.

I agree with your remarks that it is not in the best interests of the electrical industry to surround experiments necessitating the use of mains with an atmosphere of danger, but after twenty-eight years in the electrical industry it is still common to meet amateurs who do not realize the risks they run in handling mains without taking care that they themselves are insulated from earth and from between conductors, and I am of the opinion that such precautions ought to be taught to children in school.

Further, with reference to the polarity testing, why not advocate the use of a compass needle?—W. E. RICHARDSON General Manager (Urban District Council of Aberdare).

*[We do not recommend readers to use a compass needle for testing polarity of the mains simply because every reader has salt or vinegar available, but not every reader has a compass needle; and since Mr. Richardson seems so concerned for the safety of the general public, might we suggest that he could indite letters to a more useful purpose to the manufacturers who supply components for the electrical industry. It is well known that there is not a respectable switch on the market. One has merely to remove the cover of the house switch to discover a far more potent source of short circuitings, in the miserable terminals with ill-fitting screws used to connect the switch to the mains. We shall continue to advise our readers to test the polarity of the mains by the acidulated method in question. This correspondence is now closed.—Ed.]*

**Polarity of the Mains**

SIR,—Referring to your statement under the letter of a correspondent ridiculing the idea of electrolysis taking place in a lead water-pipe if a copper is attached to it. Electrolysis is possible. *[It is not.—Ed.]* It is a constant source of trouble in the lead sheathing of underground telephone and telegraph cables and is caused by leakage currents.—C. G. WISDOM (London).

**The Same Old Suggestion**

SIR,—I am a very interested reader in your new paper, so interested in fact that I follow the instructions with reference to the "Do You Know's" and "Data Sheets" and cut them out for my notebook. In doing so, I find that I sometimes, not always, destroy parts of other interesting articles on the rear of these notes, so that whenever I come to re-read an old article I may be faced with the nuisance of finding the most interesting part missing. My I suggest that a point may be made of always printing these articles so that the rear will only be advertisement.

Hoping this suggestion may meet with your approval, and congratulating you on your splendid paper.—C. MEADOWS (Birmingham).

*[An ideal arrangement, undoubtedly, but one impossible in actual practice.—Ed.]*

**High-power Transmissions**

SIR,—It seems to be fashionable to-day to deplore the tendency of broadcasting transmitters to increase their power. But is this really such a bad thing for the listener of small means? For instance, a modern three-valve is capable of putting up a performance that, if stations had

continued to use the power that they were using, say, four years ago, would have been possible only on a complicated and expensive five-valve set.

If this trend continues, it seems to me quite logical to assume that all one will need in the near future is a sharply-tuned two-valve set with properly compensated output to receive a generous bag of foreign stations.

I should also like to add a word of congratulation on your splendid paper.

It certainly seems strange that we who are interested in the technical side of broadcasting should have had to wait nearly ten years for a paper that is really instructive and deals with all the aspects of our hobby.

I am not sure that the reason for your success in this direction is that you realize that *your readers*—and not "the trade"—really need looking after. Another reason is that you refrain from making absurd claims for your sets (a popular weekly, in describing one of its receivers recently, claimed that "earthing the moving vanes of the tuning condenser was another veritable triumph").

Now for a grouse. Why don't you pay a little more attention to the question of modernizing existing receivers? You give the impression that, if one wants to build one of your sets, one would have to scrap all the components in one's present receiver. Why not give a list of optional values for condensers and resistances? For instance, I have failed to notice in the following alternatives any appreciable difference in results:—

- Grid condenser—.0002 or .0003.
- Reaction condenser—.0002, .0003, .0005.
- Decoupling 1st L.F.T.—1 or 2 mfd. and 20 up to 50,000 ohms.
- Transformer—Ordinary or parallel feed.
- Decoupling screen of S.G. valve—1 or 2 mfd.

And so on throughout the set.—W. A. WILLIAMS (Gowerton).

**Wanted—An Efficient One-valver**

SIR,—You would greatly oblige me, and I believe quite a number of readers of PRACTICAL WIRELESS, by issuing a circuit for an efficient one-valver set. There are numerous occasions when some of the household can't be annoyed with the wireless, or perhaps entertaining friends, and the particular one who wants to hear some particular item is forced to forgo the pleasure to please the majority. Then there are times when you want to hear the end of the programme, but the early retirement of the household makes this impossible. So I believe a one-valve set, not merely for local reception, but capable of giving a supply of foreigners, would be quite popular.

Wishing PRACTICAL WIRELESS every success.—EDWARD LOGUE (Glasgow).

**Wet or Dry H.T.**

SIR,—With reference to the above answer in to-day's PRACTICAL WIRELESS, I would like to suggest that you recommend your correspondent to buy a Milnes' H.T. Supply Unit, of which you have a note on your last page, under "Catalogue Received."

I have had one in use about a year and cannot speak too highly of it. It is far superior to the Leclanche cells or dry H.T. batteries. It is trouble-free and requires no attention.—P. G. BECK (Dalston).

[P.S.—I have no connection with the makers and they do not know me.]



**NEW WIRELESS INSTRUCTION**

The I.C.S. Wireless Courses cover every phase of wireless work, from the requirements of the youth who wishes to make wireless engineering his career to the man who wants to construct a broadcasting set for his home, and, at the same time, to know how and why it operates and how to locate any faults that may develop.

No branch of industry has ever progressed as rapidly as wireless and the rate of progress is increasing. Only by knowing thoroughly the basic principles can pace be kept with it. Our Instruction includes American broadcasting as well as British wireless practice. It is a modern education, covering every department of the industry.

**OUR COURSES**

Included in the I.C.S. range are Courses dealing with the Installing of radio sets and, in particular, with their **Serviceing**, which to-day intimately concerns every wireless dealer and his employees. The Operating Course is vital to mastery of operating and transmitting.

There is also a Course for the wireless salesman. This, in addition to inculcating the art of salesmanship, provides that knowledge which enables the salesman to hold his own with the most technical of his clients.

We will be pleased to send you details of any or all of these subjects. Just fill in and post the coupon, or write in any other way, stating which branch of Wireless interests you—the information you require will be forwarded at once.

**—YOU MAY USE THIS COUPON—**

International Correspondence Schools, Ltd.,  
Dept. 94, International Buildings,  
Kingsway, London, W.C.2.

Without cost, or obligation, please send me full information about the Courses I have marked x

- THE I.C.S. WIRELESS COURSES
- THE I.C.S. RADIO COURSES

Name .....

Address .....

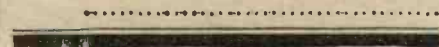

**Short Wave Section**

(Continued from page 562.)

number and spacing of the holes, shown by dotted circles in Fig. 2, is governed by the number of turns of wire that the grid winding of each coil is to contain, as the grid winding is eventually threaded through these holes. They should, of course, be of a diameter just large enough to clear the 18-gauge wire, and they should be "staggered" so as to follow exactly the spiral formation of the winding. All the other holes in the ebonite parts used in the construction of the coil formers should be drilled and tapped 6 B.A. size. Each former is assembled by bolting the side ribs to the end pieces or rings by means of 6 B.A. screws run into the tapped holes prepared for them.

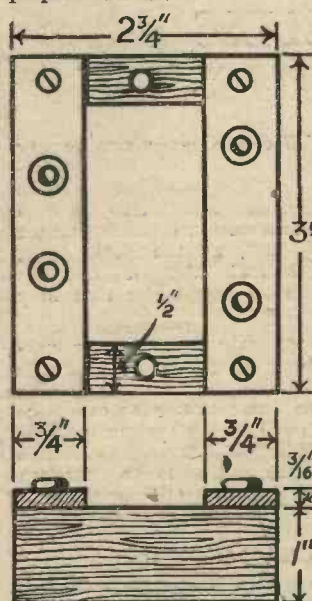

Fig. 4.—A suitable holder for the coils described in this article.

formers, the next step is to prepare the windings.

**Winding the Coils**

The 18-gauge enamelled wire used for the grid windings is formed into a spiral or helix before threading it through the holes in the ribs or fins of the coil-former. The necessary procedure is quite easy: wind a sufficient length of the 18-gauge wire on to a tube or cylinder of some sort measuring about 2 1/2 in. diameter. On completing the winding, and releasing its ends, the wire will spring out to a diameter of about 3 in. and may be slipped right off the tube, which plays no further part in the work. The spiral of wire thus formed is cut into sections containing the right number of turns for the grid winding of each coil that is being constructed. Actually, one should allow half a turn over the exact number required in each section, so as to have the necessary margin for connecting the ends of the winding to the coil pins.

Next, these spirals of wire forming the grid windings have to be threaded through the holes in their appropriate formers. This is quite an easy job when you have got the knack of it. Simply hold the coil-former in one hand and the spiral of wire in the other, so that they are parallel. Then, while slowly rotating the coil-former, thread the end of the wire through each of the holes in turn, until the complete winding has been worked into position

without bending it out of its helical shape. Insert the coil-pins in the holes prepared for them, and connect the ends of the grid winding (after scraping off the insulating coating of enamel) to the pair of pins spaced 1 1/2 in. apart. To complete the coil, wind a few turns of the 30-gauge enamelled wire into the narrow slots cut in the ebonite fins, so as to form a reaction winding. The ends of this winding should be connected (after scraping them) to the remaining pair of coil-pins.

The number of turns required for the reaction winding depends, of course, on various factors, such as the capacity of the reaction condenser with which the coils are to be used, the aerial and the method of coupling it, etc., so the optimum number of turns can best be found by actual experiment. An elevation of a completed coil is shown in Fig. 3. If you have any bright-coloured enamels handy, it is a good plan to paint the top ring of each coil in a distinctive colour, so that the correct coil for any given waveband can be distinguished at a glance without troubling to look at the number of turns in the winding. For instance, a 2-turn coil might be marked with red, a 4-turn one with blue, and so on.

**A Convenient Holder**

A holder for a set of coils made on these lines can be constructed very easily, as shown in Fig. 4. The holder consists simply of two strips of ebonite measuring 3 1/2 in. by 3/4 in. cut from the sheet 3/16 in. thick, secured to a couple of pieces of stripwood (with woodscrews). The pieces of stripwood measure 2 1/2 in. by 1 in. by 3/4 in. thick. The method of construction is obvious from a glance at the diagram. Four metal sockets, to fit the coil-pins, are mounted on the strips of ebonite, the spacing of these sockets being arranged, of course, to coincide exactly with the spacing of the coil-pins.

An easy way to ensure that the holes for the sockets are marked out correctly before drilling, is to take one of the completed coils and press it down on to a piece of soft blotting-paper so that the ends of the coil-pins leave an impression on the surface of the blotting-paper. This can then be used as a template for marking out the positions of the holes to be drilled in the ebonite strips. The holder can be secured to the baseboard of the set by passing long woodscrews down through the fixing-holes in the pieces of stripwood. Leads from the four sockets are connected, of course, to the appropriate terminals on the other components in the set. It may be necessary to reverse the leads to the reaction sockets if on test one finds that no reaction effect is obtainable. It is important to see that the grid and reaction windings on each coil are put on in the same direction, and that the connections to the coil-pins are uniform, so that if a correct reaction effect is obtained with one coil in the series, it will hold good for the others also.

The number of turns required in the grid windings of the coils depends to some extent on the maximum capacity of the tuning condenser with which they are to be used. As a rule, however, a series of coils with grid windings of 2, 4, 6, and 8 turns will be found to cover the short waveband satisfactorily. In order to reduce the damping effect of the aerial and to promote proper reaction, the aerial should be coupled to the grid end of the coil by way of a fixed or, preferably, a semi-variable condenser of very small capacity.

**GRIP**



**BELLING-LEE**  
FOR EVERY RADIO CONNECTION

Advt. of Belling & Lee, Ltd., Cambridge Arterial Rd., Enfield, M.d.

DESIGNS FOR APPARATUS FOR ANY RADIO PURPOSE, INCLUDING TRANSMISSION, OVERSEAS ENQUIRIES INVITED: ANY APPARATUS SUPPLIED. CONSTRUCTIONAL WORK UNDERTAKEN.

We undertake to solve your problems, including obtaining Amateur Transmitting Licence. Whatever your difficulty, write us. Charges: 3/- per query, four or more, 2/6 each, with diagrams. Radio Technical Agency (Dept. P.L.W.), 2, Westgate Chambers, Newport, Mon.

**OUR CATALOGUE**

contains much useful information on the winding of small transformers and chokes.

3d. POST FREE.

LUMEN ELECTRIC COY., 9, Scarisbrick Avenue, Litherland, Seaforth, Lancs.

**TRANSFORMERS.**

Large quantity of genuine Ericsson Transformers. New and guaranteed. Original price, 17/6 each. Ratios 2-1 and 4-1. Our price, 3/3 each. SPEAKERS. Genuine "Six-Sixty" speaker Units, brand new and guaranteed. Limited number only. Original cost, 6/6; to clear, 1/9 each. The chance of a lifetime; send order quickly! Carriage paid U.K. Cash with order. Pioneer Radio Manufacturing Co., Ltd., Coptic Street, New Oxford Street, W.C. Museum 9607. Trade enquiries invited.



NINE for 6d.

If unobtainable from your local dealer send 1d. worth of stamps direct.

**IN A JIFFY WITH A KNIFFY**

That's how quickly, neatly, and easily that unruly piece of flex or wire can be made to "stay put" wherever it is wanted.

The full-size illustration shows the double grooves at bottom and the circular groove for the looping over of flex, or for hanging pictures, etc. There are hundreds of uses for the Kniffy. But it must be a Kniffy—refuse substitutes. Made in many colours to match surroundings. State colour required.

Reg. Design No. 772447. Patents Pending.

**KNIFFY PIN**

KNIVETON CABLE WORKS LTD., QUEENSWAY, PONDER'S END, MIDDLESEX.

Fix it with a 'KNIFFY'



LET OUR TECHNICAL STAFF SOLVE YOUR PROBLEMS

REPLIES TO



If a postal reply is desired, a stamped addressed envelope must be enclosed. Every query must bear the name and address of the sender. Send your queries to The Editor, PRACTICAL WIRELESS, Geo. Newnes, Ltd., 8-11, Southampton St., Strand, London, W.C.2.

QUERIES and ENQUIRIES by Our Technical Staff

The coupon on this page must be attached to every query.

SPECIAL NOTE

We wish to draw the reader's attention to the fact that the Queries Service is intended only for the solution of problems or difficulties arising from the construction of receivers described in our pages, from articles appearing in our pages, or on general wireless matters. We regret that we cannot, for obvious reasons—

- (1) supply circuit diagrams of complete multi-valve receivers.
- (2) Suggest alterations or modifications of receivers described in our contemporaries.
- (3) Suggest alterations or modifications to commercial receivers.
- (4) Answer queries over the telephone.

NOT THE AERIAL

"I shall be extremely obliged for your assistance in solving the following problem. I purchased a set, second-hand, which incorporated a three-valve circuit, for use by my brother near Cardiff. I tested the set at Balham, and had fair results on a very poor aerial which was just laid on slightly elevated brickwork surrounding a roof. I had a number of medium-wave stations at fair strength. The quality of the reception was not up to standard, being harsh. The set was despatched to Cardiff and received in good order. A new aerial and earth were erected but when the set was tested no result was obtained until the G.B.2 plug was removed. Then the set functioned at fair strength on the Daventry National. Results on the short-waves were very poor. This was about four weeks ago, and since then reception has improved slightly, but the plug has still to be kept out. Can you solve this problem?"—(J. J. Mitcham.)

The efficiency or otherwise of an aerial would not make any difference to the quality of reception in a receiver, so that if the tone was not up to standard before sending the set to your brother, his more efficient aerial would not effect any improvement in this direction. It seems certain that the reason why the set functions with the grid bias plug out, and not with it in, is that the G.B. battery is run down; perhaps it was accidentally short-circuited in transit. A new battery, in this case, will put matters right and should also improve the tone. It is possible that this would be further improved by the use of the valve types recommended. The P.M. 252 is a semi-power valve capable of handling a very fair load if suitably biased. Two of your present valves are designed for high-frequency stages, and they are being used at present, we presume, for detector and low-frequency stages.

POOR QUALITY

"I wish to ask you to help me in my difficulty, but I hope you will not laugh when I explain how I solved it. My loud-speaker did not give me nice music; I cannot explain what was wrong as I am not a technician nor a musician, but there was something wrong somewhere. I should explain that the speaker is of the horn type, and this is a fairly large affair. Now I was dusting inside the horn one day when it was playing, and when my hand was inside the music 'cleared up.' After a little experimenting I found that by poking the duster right down as far as I could inside the horn the music was much more pleasing. I know this is not very expert, but it worked, and I should therefore like to know whether you could suggest a reason for the bad music and how to cure it without the duster."—(F. B. H., Bedford.)

We would suggest, first of all, that the reproduction is quite all right, but your loud-speaker is all wrong. The type of speaker you refer to is noticeably lacking in bass response, and it may have been this that you were noticing. When you muted the speaker with the duster, you may have cut down the volume sufficiently, or otherwise removed the "screechiness" or over-emphasis of the top notes, and so made the tone more to your liking. The first thing to do, therefore, is to try a modern speaker of the cone variety. If this

sounds O.K., as we expect it will, then all well and good. If, however, reproduction is still not as you like it, fit a larger output valve and/or increase the H.T. and G.B. values for this valve. If the receiver employs very old components, then we suggest you rebuild it or at least make up a modern set from modern parts.

D.C. MAINS

"I am just moving into a house in which electric light is supplied, but of the D.C. variety. I have a three-valve battery set, and should like to dispense with the dry cells now and take advantage of the juice which is laid on. I should much appreciate, therefore, your suggestions as to what I must do to my set—if such is necessary—and what apparatus I must buy."—(K. H., Muswell Hill.)

DATA SHEET No. 11  
Cut this out each week and paste it in a notebook.  
CAPACITY OF AN AIR CONDENSER

Total Plate Area in sq. in.	1-32in.	1-20in.	1-16in.	3-32in.	1/4in.
1	7.2	4.5	3.6	2.4	1.8
3	21.6	13.5	10.8	7.2	5.4
10	72	45	36	24	18
20	144	90	72	48	36
30	216	135	108	72	54
40	288	180	144	96	72
100	720	450	360	240	180

The above capacities are in micro-microfarads.

The first and most essential thing to do is to fit a 2 mfd. condenser in the earth lead of your set, together with a small aerial in series with the aerial lead inside the set. This ensures that the actual receiver is isolated from the mains. For supplying the high tension, you need simply a smoothing choke, which must be inserted in the positive lead from the mains, and a 4 mfd. condenser across the negative and positive leads on the set side of the choke. For voltage-dropping purposes, ordinary wire-wound resistances should be used, and perhaps you could not do better than make up the D.C. unit described in our pages a fortnight ago. If you do this, the 2 mfd. condenser in the earth lead will automatically be included. No alteration should be necessary to your set.

PUSH-PULL TROUBLE

"I have a push-pull stage in my set, and it has been working perfectly now for twelve months or so. Recently, however, there has developed an objectionable whistle. This is not a heterodyne whistle as it is present even when the set is switched on very early in the morning. It is fairly loud, and very high in tone, and I rather fancy there is distortion present, although the output is so great that distortion is hard to notice. Can you suggest any way of finding where the whistle comes from, and cures?"—(D. J., Golders Green.)

If you can obtain a milliammeter, and insert this in the anodes of the two push-pull valves in turn, you will no doubt find that one of the valves is losing its emission. This is resulting in an unbalancing of the output stage and no doubt H.F. oscillation. Replacement of the defective valve should restore the set to its former perfection. As the set has been working for a year, it is quite conceivable that all of the valves are beginning to feel the worse for wear, and you should therefore have them tested.

SPEAKER HUM

"I have got an old type of moving-coil speaker which was formerly operated by a 6-volt accumulator. I have just finished building the all-Mains Express, and wish to use this speaker, although I do not want to keep the accumulator. Can I use it as a smoothing choke in the H.T. lead? If not, is there any other

part of the circuit in which I can include it to get the necessary field excitation?"—(E. W., Hampstead.)

You cannot use the speaker in question anywhere in the Mains Express Three. The simplest way for you to use the speaker from the mains is to buy a mains transformer with an output of 12 volts, 1.5 amps, a Westinghouse A.3 metal rectifier, and a 2,000 mfd. electrolytic condenser. The rectifier is joined to the output of the transformer, and the output of the rectifier to the two field terminals of the speaker. The large condenser is joined across the field terminals. The output from the arrangement is 9 to 10 volts, and if your speaker will not take this, join a 6 ohm variable resistance in series with one lead to the speaker.

SUPER HET.

"I am buying a set of sup.-het. coils, and am going to build a 5-valve sup.-het. I have on hand a two-gang condenser, and should like to use this in the set. Is it necessary to purchase a three-gang condenser, or can I join another variable condenser to the spindle of my two-gang to provide three-gang condensers. My two-gang arrangement consists of two ordinary condensers joined together with a coupling unit, and there is an extension of the condenser spindle at each end, so that it would be quite simple to join up the third condenser."—(A. F. T., Hull.)

The essential feature of the sup.-het. is the one-knob control. To achieve this the condenser employed for the oscillator tuning is made with vanes of a special shape. If you gang your third ordinary condenser, you will not get matched tuning over the entire range of the tuning scale, and you must, therefore, either fit the condenser to the panel and use it as a separate control, or purchase a special sup.-het. ganged condenser which is made for the job.

PHONES AND THE MAINS

"I am building a two-valve set and an eliminator for working this from the mains. I am a long-distance fan, although my wife is not. I should therefore like to use telephones during part of the evening for the reception of foreign stations, but am not sure whether there is any risk attached to the wearing of these as the set is operated from the mains. I should be glad of your advice."—(J. T., Glenfarrel.)

This would most emphatically be a dangerous proceeding, and we must warn you against wearing headphones unless you carry out the following precautions. In the anode circuit of the last valve you should fit an output transformer having a ratio of 1 to 1, so that the phones are completely isolated. In addition, it is advisable to ensure that all control knobs have the small grub screw which holds them in place either sunk below the surface of the knob or covered with insulating material. We do not know the arrangement of your circuit, and cannot therefore give you any other details, but you should assure yourself that all controls are at earth potential, and that all insulation is sound. Remember the old saying, "Prevention is better than cure."

NO SUBSTITUTIONS

L. S. (Peckham), B. J. (Hampstead), R. W. F. de A. (St. Osyth), and others, ask whether it is permissible to use various components which they have on hand in the construction of one of the sets described in our pages. We must emphasize that it is not advisable to depart from the designers' specification, not because the component which it is designed to substitute may not be so efficient, but because owing to physical dimensions the layout may be so modified as to lead to trouble, either from interaction between wiring or components. We should like readers to bear this point in mind, therefore, and although we appreciate that it is often the case that a particular component, say a transformer, is specified, and the reader may have a spare transformer of a different make on hand, we cannot agree to any substitution, and must insist that the receivers are made up exactly to specification.

FREE ADVICE BUREAU COUPON

This coupon is available until Dec. 10th, 1932, and must be attached to all letters containing queries.

PRACTICAL WIRELESS, 3/12/32.

# CATALOGUES RECEIVED

To save readers trouble, we undertake to send on catalogues of any of our advertisers. Merely state, on a postcard, the names of the firms from whom you require catalogues, and address it to "Catalogues," PRACTICAL WIRELESS, Geo. Newnes, Ltd., 8/11, Southampton St., Strand, London, W.C.2. Where advertisers make a charge, or require postage, this should be enclosed.

### For Your Mullard Catalogue

READERS who have a Mullard loose-leaf catalogue should get the new sheet V.R.123 which has just been issued, describing the Mullard low-consumption pentode type P.M.22A. For use with a 2-volt accumulator, this output valve is designed particularly for portables, and small battery operated receivers. The leaflet can be obtained on application to Mullard Wireless Service Co., Ltd., Mullard House, Charing Cross Road, London, W.C.2.

### Seradex Products

WE have received from Trevor Pepper, of Birmingham, several leaflets giving prices and particulars of various Seradex components, including moving iron metres for panel mounting; filter chokes; mains transformers; resistance nets; glasswound resistors; filter condensers and the Seradex A.C.L.T. charger. Readers can obtain any of these lists free of charge by mentioning PRACTICAL WIRELESS. The address is 48, Wake Green Road, Moseley, Birmingham.

### Six-Sixty Valves

IN a neat booklet just issued by Six-Sixty Radio Co., Ltd., a complete range of these well-known valves is given. Full particulars and prices of upwards of thirty different kinds of valves are included, together with the characteristic curve of each valve. The address is 17-18, Rathbone Place, Oxford Street, London, W.1.

### Electriclocks

THERE is much to be said for the modern electric clock which requires no winding, no regulating—no levelling, and no attention. An "Electriclock" gives this trouble-free service indefinitely. You just stand the clock where you want it, and plug in to the nearest point. Full particulars and prices of a comprehensive range of these new clocks are given in an attractive brochure we have received from Electriclocks and Radio, Ltd., Avenue Works, Hanover Park, Peckham, London, S.E.15. The clocks, which are for use on A.C. mains only (200 to 250 volts, 50 cycles) are driven by a special motor consuming only 1.9 watts. The various patterns of cases, in which the clock movement is housed, are fine examples of British workmanship.

### N and K "Ten Pas" Inductor Loud-speaker

THIS new speaker (Ferrand Patent) operates on an electro-magnetic system in which two iron armatures are used which can only move in a path parallel with the pole faces of the double magnets. This arrangement results in a distortionless reproduction comparable to that of a moving-coil speaker. The speaker is obtainable in handsome cabinets, of different designs, one of which is made specially non-resonant. Full details, together with diagram of connections and prices, are given in a booklet we have received from A. Brodersen, 11, Northampton Square, Goswell Road, London, E.C.1.

### Becker Kitswitch

IN receivers built up in chassis form it is good practice to assemble the on-off or wave-change switch direct on the chassis. The new Becker Kit-

switch is specially designed for this purpose. Connections are made where you can easily get at them. Once the switch is in position you just slide the chassis into its cabinet and screw in the reinforced knob through the slot in the cabinet. The switch, which is rated at 4 amps, is made of moulded bakelite, the terminals and contacts being of phosphor bronze. Further particulars of this useful switch are given in a leaflet, a copy of which can be obtained from Geo. Becker, Ltd., Wembley.

### Milnes Radio Company

WE have been advised by The Milnes Radio Company, of Cottingley, Yorks, that owing to the expansion of business they have now removed to larger premises. Their new address is Victoria Works, Church Street, Bingley, Yorks.

## Broadcast Query Corner

UNDER the above title, with the assistance of a recognised authority on foreign broadcasting matters and a regular contributor to wireless publications both at home and abroad, we are inaugurating a special Identification Service, which should prove of great assistance to our readers. When tuning in well-known stations it happens frequently that listeners pick up wireless transmission of which they fail to recognize the origin. It is to solve these little problems that the *Broadcast Query Service* has been organised.

In order that a careful search may be made it is essential that certain data should be supplied to the best of the inquirer's ability and knowledge. When sending such queries to the Editor the following rules should be followed:—

1. Write legibly, in ink. Give your full name and address.
2. State type of receiver used, and whether transmission was heard on headphones or on loud-speaker.
3. State approximate wavelength or frequency to which receiver was tuned, or, alternatively, state between which two stations (of which you have the condenser readings) the transmission was picked up.
4. Give date and time when broadcast was heard. Do not forget to add whether a.m. or p.m.
5. Give details of programme received, and, if you can, some indication regarding the language, if heard.
6. State whether and what call was given and/or kind of interval signal (metronome, musical box, bells, etc.) between items.
7. To facilitate publication of replies, append a *nom-de-plume* to your inquiry.

Although the service is mainly applicable to broadcasting stations, wherever possible replies will be given in regard to Morse transmitters (commercial stations, fog beacons, etc.) and short-wave broadcasts. For the identification, however, of stations operating on channels below 100 metres it will be evident to inquirers that a closer estimate of wavelength must be submitted than in the case of broadcasts on the medium or long waveband if successful identification is to be carried out.

All inquiries should be addressed to *The Editor, PRACTICAL WIRELESS, 8-11, Southampton Street, Strand, London, W.C.2,* and the envelope marked *Broadcast Query Service*, in top left-hand corner. Stamped addressed envelope should not be enclosed, as replies cannot be sent by post, but will be published in due course in each issue of PRACTICAL WIRELESS.

### Replies to Broadcast Queries

QUERY (Plymouth): WKJ, Rocky Point (N.Y.) on 31.71 m. (9,460 kc/s). PATIENCE (Glasgow): (1)

LR3, Radio Nacional, Buenos Aires, on 316 m. (2) LR2, Radio Prieto, Buenos Aires, on 330 m.; (3) WCAU, Philadelphia (Pa.) Columbia Broadcasting System (256.3 m.); (4) WTAM, Cleveland (Ohio) National Broadcasting Company network on 280.2 m.; (5) WPG, Atlantic City (N.J.) Columbia Broadcasting System on 272.6 m.; (6) WIOD, Miami Beach (Fla.) on 230.6 m. National Broadcasting Company network. W. PRITCHARD (W.8): WTIC, Hartford (Conn.) National Broadcasting Company network on 282.8 m. EARLY BIRD (Porthcawl): Apparently amateur experimental transmitter in your neighbourhood; must know call letters to permit identification. W. O. (Rhondda): (a) IAC, Coltano (Italy) on 35.8 m.; 45.11 m. and many other wavelengths; (b) DAN Norddeich (Germany) on 36 m. HELICON (Smethwick): According to programme, not Radio Normandie (Fécamp) unless items were altered; possibly amateur transmitter. SHORTWAVE (Torquay): YQ7LO, Nairobi (Kenya Colony) on 49.5 m. VALVER (Abernethy): New Leipzig transmitter on 389.6 m. Tests with this station have been carried out at the end of the day's programme.

### The Plays That Have Thrilled Millions!

MILLIONS of wireless listeners who have been thrilled by such plays as "The Path of Glory" and "The Mary Celeste" can now read them in book form for the first time. Five radio thrillers. 356 pages.

## RADIO PLAYS

By L. du Garde Peach

Obtainable at all Newsagents and Bookstalls, or by post, 2/9, from George Newnes, Ltd., 8-11, Southampton St., Strand, London, W.C.2. **2/6**

### Everyone Recommends

## The SLEKTUN "COLT"

**L.F. TRANSFORMER**

The finest transformer ever made at such a low price. Specified for the latest sets. Ratios: 2:1, 3:1, 4:1, 5:1.

**4/9**

SLEKTUN PRODUCTS, LTD., 21, Douglas Street, Westminster, S.W.1

### SERADEX MOULDED RESISTORS



1½ watt rating. Fitted wire ends. Made in all values from 100 ohms to 5 Megs. Price each 8d.; Per dozen 7/6. Lists for stamp.

48, WAKE GREEN ROAD, BIRMINGHAM.

## ADVERTISEMENT INDEX

	Page		Page
Belling & Lee, Ltd. ....	570	Newnes' Christmas Books ...	543
Bennett College Ltd. ....	527	Pearsons' Christmas Books ...	567
British General Mfg. Co. Ltd. ....	526	Pioneer Radio Mfg. Co., Ltd ...	570
British Pix Co, Ltd. ....	525	Peto-Scott Ltd. ....	552 and 553
Colvern, Ltd. ....	567	Radialaddin, Ltd. ....	526
Cossor, A. C., Ltd. ....	Front Strip and 541	Radio Instruments, Ltd. ....	Back Cover
Edison Swan Electric Co. Ltd. ....	Inside Front Cover and 527	Radio Technical Agency ...	570
Heraud, E. J., Ltd. ....	526 and 558	Ready Radio, Ltd. ....	561
International Correspondence Schools, Ltd. ....	569	Seradex Radio ...	572
Kniveton, Ltd. ....	570	Simpson's Electricals, Ltd. ....	525
Lissen Ltd. ....	528	Slektun Products, Ltd. ....	572
Lumen Electric Co. ....	570	Telegraph Condenser Co., Ltd. ....	551
Nash Products, Ltd. ....	525	Telsen Electric Co., Ltd. ....	545, 546, 554, 563
Newnes' Home Movies ...	Inside Back Cover	Wates Radio Ltd. ....	526
Newnes' Radio Plays ...	572	Wilkins & Wright Ltd. ...	525
		Wright & Weaire Ltd. ...	551

# Home Talkies are now practicable

**M**OST people know that moving pictures in the home are well established—yet how many realise that home talkies are now practicable? The accompanying picture shows a strip of talkie film specially made for home use and carrying in the peculiar serrated line at the side of the picture all of the delicate graduations of speech and music.

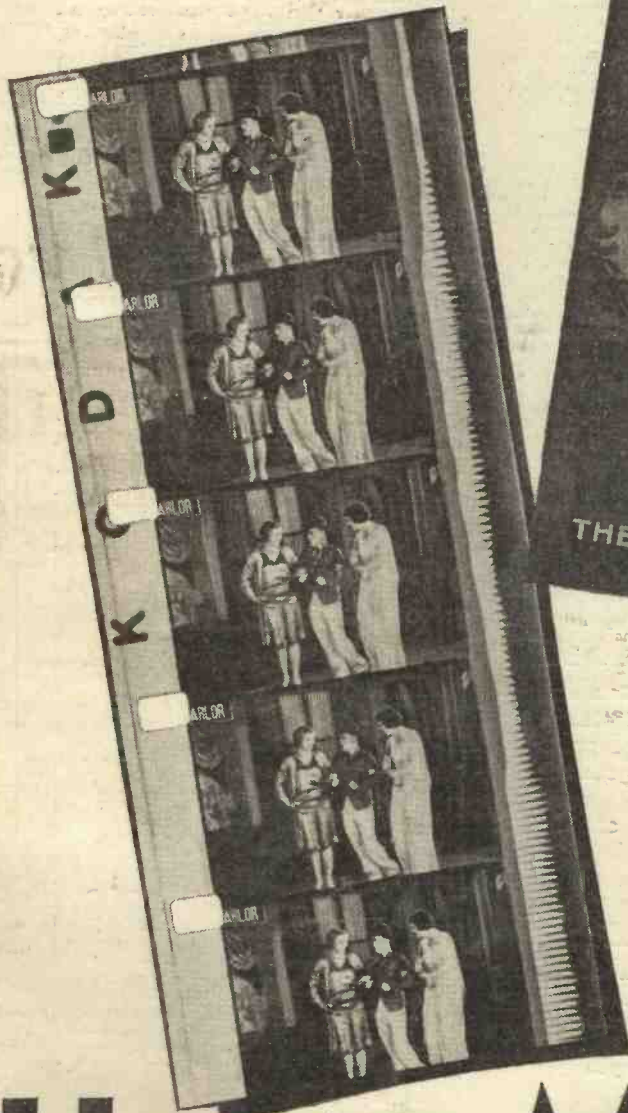

**H**OME MOVIES and Home Talkies, the brightly written monthly magazine devoted entirely to amateur cinematography, is now running a series of articles by an expert describing in simple language just how talkies are made. Other fascinating articles in the current issue, which, by the way is a specially enlarged Christmas number, are "The Fun of Amateur Filming," which describes the adventures and experiences of an amateur whose films have become famous; "How to Choose a Party Programme," from the many film hire libraries; "Choosing your Cine Gifts for Christmas," an illustrated supplement; and "How to Produce a Film," by Adrian Brunel, the well-known director.

SEND POSTCARD TO-DAY FOR SPECIMEN COPY

"Home Movies" is obtainable at all Newsagents, Bookstalls and Dealers, or by post 7d. (Subscription rates: Inland and Abroad 7/6 per annum, Canada 7/- per annum) from George Newnes, Ltd., 8-11, Southampton St., Strand, London, W.C.2.

NOW ON SALE

# HOME MOVIES 6d

Specially enlarged Christmas Number

# 'ANTINODAL'

## SHORT-WAVE Coil Unit the Heart of the EMPIRE THREE



Specification of the "Antinodal" for the Practical Wireless "Empire Three" was made obviously because there is no other short-wave coil that can give such even reception and smooth reaction throughout the entire short-wave band. Its critical handling of all the short wavelengths from

### 12 to 80 metres

is universally acknowledged by experimenters and others as amazing. By its critical tuning they have been able to receive and separate short-wave stations from all over the world. Thus "Antinodal" has absolutely overcome short-wave reception difficulties and has definitely revolutionised present short-wave practice.

### ANTINODAL—

#### What it is and what it does

"Antinodal" is a short-wave coil incorporating a loading inductance which provides or allows an alternative electrical position for the aerial coupling coil. It bridges dead spots and always provides sufficient SMOOTH reaction to produce oscillation at all tuning positions. Stations hitherto difficult or impossible to receive can be tuned in with ease and certainty.

Antinodal Short-Wave Coil Unit.  
List No. BY 33. Base 2 1/2 x 3 1/2 ins.  
Overall height 3 1/2 ins.

### 6/9

### ANTINODAL BROCHURE FREE

Of absorbing interest to all Short-Wave enthusiasts, this booklet deals fully with Short-Wave problems and their solution and describes in detail the Antinodal Short-Wave Coil Unit.

Fill in and post, in 1d. stamped unsealed envelope, the coupon below for a free copy.

To Radio Instruments, Ltd., Croydon, Surrey.

Please send me, post free, a copy of the "Antinodal" Brochure and the Hypermite Leaflet.

Name.....

Address.....

PRW

#### For the "Empire Three"

Primary Inductance  
**50**  
HENRIES



### 12/6

### HYPERMITE L.F. TRANSFORMER

For high amplification without distortion, L.F. stages will be safer and more satisfactory with "Hypermite," which is specified in modern circuits for its high primary inductance, general superiority of performance and small size for compact assembly. It is the best nickel iron alloy core transformer at its price.



LTD

The Advertisement of Radio Instruments, Ltd., Croydon, Surrey. Telephone : Thornton Heath 3211.

Big Christmas Number

# Practical Wireless

3!

Published by  
**GEORGE  
NEWNES  
LTD.**

Vol. 1—No. 12  
DECEMBER 10th, 1932  
*Registered at the G.P.O. as a Newspaper.*

## MAKE IT A RADIO XMAS



### SEE OUR 16 PAGE PHOTOTONE SUPPLEMENT

*Whether it's bought  
Or whether it's built,  
Earth your Receiver  
By fitting a FILT!*

**GRAHAM FARISH**  
**FILT**  
PERCOLATIVE CHEMICAL EARTH

If you cannot readily  
obtain a FILT from  
your radio dealer order  
direct, post free, from  
sole manufacturers:  
**GRAHAM FARISH  
LTD.,**  
201, Masons Hill,  
Bromley, Kent.

**PRICE**  
**2/6**  
**COMPLETE**



**Lewcos**  
REGD

## Radio Components

Fundamentally sound in every sense, Lewcos precision-made components owe their superiority to their creators' long experience as first-class wire manufacturers. All reputable dealers stock and confidently recommend

Lewcos components of every type.

*Descriptive Literature of the Components you need will be supplied on demand to Radio Publicity Dept. W.*



**THE LONDON ELECTRIC WIRE COMPANY AND SMITHS, LIMITED, CHURCH ROAD, LEYTON, LONDON, E.10**

# THIS PICK-UP DOES JUSTICE TO THE RECORD

A pick-up which gives the record its due and reproduces every subtle inflexion of harmony at its tone value. Such is the B.T.H. Pick-up, the choice of leading radiogram manufacturers and radio engineers; and the most widely used of any.

Your dealer will be pleased to demonstrate the various models in the B.T.H. range.



**B.T.H. SENIOR PICK-UP (1933 model).** This has been completely re-designed and gives an even better response curve than hitherto. Free coupling of the head to the tone arm reduces pressure on records and facilitates needle changing. Price £2.2.0. (Complete with volume control).



**B.T.H. MINOR PICK-UP** has been re-designed and improved and now includes a special volume control fitted in the base of the tone-arm pillar. This model is constructed in a one-piece moulding of B.T.H. "Fabrolite" and is recommended to those requiring a highly efficient but inexpensive pick-up. Price 25/-.

**B.T.H. SENIOR PICK-UP** complete with four adaptors to fit standard tone-arms. Price 27/6.



## PICK-UP and Tone Arm

EDISWAN RADIO=100% BRITISH

THE EDISON SWAN ELECTRIC CO. LTD.



155 CHARING CROSS RD., LONDON, W.C.2  
W.201

# "It's going to be a real radio Christmas now that I've got an R & A Challenger"



You cannot do better than scrap your present loud speaker and invest in the incomparable "Challenger," the instrument which will give you a thousand-fold return in reproduction of speech and music. Read the "Wireless World" Test Report on the "Challenger" and you will realise that the ideal has been well-nigh achieved.

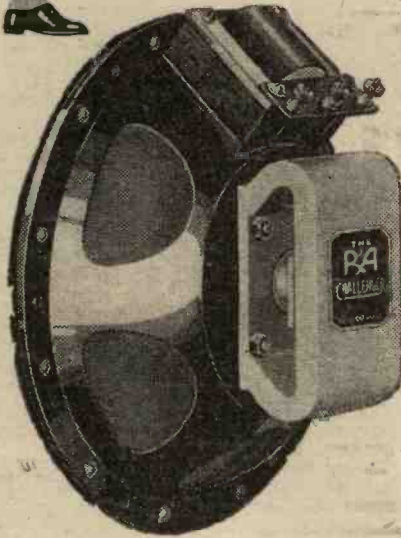

**35/-**

INCLUDING  
3-ratio  
Ferranti Transformer

**"WIRELESS WORLD" states:**

"The performance of this unit is such that it merits discussion from an absolute standpoint and without regard to the very reasonable price asked. . . . Overall sensitivity slightly better than the average . . . reproduction of bass below 100 cycles quite definitely above average . . . as a result of the well-maintained output down to 50 cycles a full-bodied bass is obtained without 'boom.' Reproduction of speech is natural and unforced, and the balance in music is exceptionally good."

Ask your dealer to demonstrate, and resolve to make yours a real Radio Xmas with an R & A "Challenger."

REPRODUCERS & AMPLIFIERS LTD., WOLVERHAMPTON.



Get **BRILLIANT**  
**RESPONSE** from your  
**GRAMOPHONE RECORDS**  
with a **HARLIE PICK-UP**

**2/6**  
**DOWN**



MODEL 36 Cash Price 27/6

Enjoy a new standard of reproduction of gramophone records by playing them through your wireless set with the wonderful Harlie Pick-Up. Simple fixing and connecting instructions supplied.

Modern in design, superb in performance, the new Harlie models are definitely "a season ahead" of any others. They produce a fidelity of tone which is really amazing, remarkable frequency response and range giving uniform tonal quality. Old or new, records are definitely improved when played through one of these superb Pick-Ups. Spring counter-balance ensures correct weight on record and ball-bearing base allows free swing, reducing wear to a minimum. Every Harlie Pick-Up is individually tested for tone accuracy, and has built-in Volume Control.

H.P. Terms—2/6 down, 2/6 in 7 days and 5 monthly payments of 5/-.

**HARLIE TONE SELECTOR**

A wonderful invention that definitely improves the results obtained with your speaker. It gives you the choice of different tones, normal, brilliant, bright, mellow, deep, also acts as a whistle filter, and when used with a Pick-up eliminates needle scratch.



Obtainable from 1/- down, 1/- in 7 days, and 2 monthly payments of 1/6. Cash price 4/6. There is a limited number of the De-Luxe model at 10/- each on 7 days' approval.

**FREE**

An interesting booklet which tells you how a pick-up works—how to play records with a superb realism through your radio and how to eliminate needle scratch. Post coupon below for your FREE copy now.

*Harlie*  
L.P.

Cambridge Arterial Rd.  
Enfield, Middlesex.

Please forward:— FREE BOOKLET  
TONE SELECTOR  
DE LUXE PICK-UP } Cross out items not  
wanted.

For which I enclose P.O value.....(no stamps).

Name .....

Address .....

Pr.W.I.



# PETO-SCOTT RADIO BY MAIL

## ORDER YOUR XMAS RADIO NOW!

**TELSEN JUPITER S.G.3.** Complete kit as advertised, less valves and Cabinet. Cash Price £3/17/0. Carriage Paid. Balance in 11 monthly payments of 7/- only. **Send 7/- only**

**SLEKTUN SCOUT S.G.3.** S.G., Detector and Power. Kit "A," less valves and cabinet. Cash or C.O.D., £3/19/6. Carriage Paid. Balance in 11 monthly payments of 7/3. **Send 7/3 only**

**LISSEN S.G.3 PENTODE BATTERY SET.** Send In walnut cabinet complete with speaker, valves and all necessary batteries. Wave-length calibrated. Cash Price, £8/17/6. only Carriage Paid. Balance in 14 monthly payments of 13/4. **Send 13/4 only**

**COSSOR MELODY MAKER MODEL 335.** Complete with valves, speaker and cabinet. Employs Cossor Variable-mu S.G., H.F. stage, Detector and Power Valves. Cash Price £7/17/6. Carriage Paid. Balance in 11 monthly payments of 14/10. **Send 10/- only**

**COSSOR MELODY MAKER MODEL 334.** Send With Metallised Variable-mu S.G. and Detector Valves, Power Valve and Cabinet. Cash Price, £6/7/6. Balance in 11 monthly payments of 11/10. **Send 10/- only**

**READY RADIO KENDALL-PRICE S.G.4.** S.G., Detector, L.F. and Power. Complete kit less valves and cabinet. Cash Price £4/6/6. Carriage Paid. Balance in 11 monthly payments of 8/-. **Send 8/- only**

**READY RADIO "METEOR" S.G.3.** Three-valve screened-grid receiver, with valves, cabinet and permanent-magnet moving-coil speaker. Covers short, medium and long waves without coil changing. Cash Price, £8/17/6. Carriage Paid. Balance in 11 monthly payments of 16/3. **Send 16/3 only**

**READY RADIO "METEOR" S.G.3.** Three-valve screened grid receiver. Covers short, medium and long waves without coil changing. Cash Price (less valves and cabinet), £3/15/3. Carriage Paid. Balance in 11 monthly payments of 7/-. **Send 7/- only**

**EPOCH "20 C" PERMANENT MAGNET MOVING-COIL SPEAKER.** (New Edition.) With 5-ratio input transformer. Cash Price £1/15/0. Carriage Paid. Balance in 5 monthly payments of 6/6. **Send 6/6 only**

**BLUE SPOT UNIT AND CHASSIS, Type 99 P.M.** Including matched transformer. Cash Price £2/19/6. Balance in 11 monthly payments of 5/6. **Send 5/6 only**

**R & A "VICTOR" PERMANENT MAGNET MOVING-COIL SPEAKER DE LUXE.** With 6-ratio input transformer and protecting grille. Cash Price £3/10/0. Carriage Paid. Balance in 11 monthly payments of 6/5. **Send 6/5 only**

**R & A "CHALLENGER" PERMANENT MAGNET MOVING-COIL SPEAKER.** With special Ferranti multi-ratio input transformer. Cash Price, £1/15/0. Carriage Paid, £1/15/0. Balance in 5 monthly payments of 6/6. **Send 6/6 only**

**W.B. PERMANENT MAGNET MOVING-COIL SPEAKER P.M.2.** With 3-ratio input transformer. Cash Price £4/5/0. Carriage Paid. Balance in 11 monthly payments of 7/10. **Send 7/10 only**

**CELESTION P.P.M. PERMANENT MAGNET MOVING COIL SPEAKER** with impregnated diaphragm and dual-impedance input transformer. Cash Price, Carriage Paid, £2/7/6. Balance in 11 monthly payments of 4/6. **Send 4/6 only**

**SONOCHORDE PERMANENT MAGNET MOVING-COIL SPEAKER,** with universal input transformer. Cash Price, £1/12/6. Balance in 5 monthly payments of 6/-. **Send 6/- only**

**BLUE SPOT 66R UNIT AND MAJOR CHASSIS.** Cash or C.O.D. £2/10/10. Carriage Paid. Balance in 11 monthly payments of 4/7. **Send 4/7 only**

**BLUESPOT SPEAKER UNIT AND CHASS S, Type 100 U.** Cash Price £1/12/6. Carriage Paid. Balance in 6 monthly payments of 5/2. **Send 5/2 only**

**EKCO H.T. ELIMINATOR A.C.25** for A.C. mains. Tapped S.G. variable, 50/80 volts and 120/150 volts max. at 25 m/A. Cash or C.O.D. Carriage Paid, £3/17/6. Balance in 11 monthly payments of 7/-. **Send 7/- only**

**ULTRA 1933 TIGER.** A.C. or D.C. mains. S.G., S.G. Detector and Pentode. Moving coil Speaker. Complete with Mazda Valves. Ready for use. Cash Price, Carriage Paid, £15/15/0. Balance in 17 monthly payments of 20/. **Send 20/- only**

**TELSEN MACNAMARA.** S.G., Detector, and Pentode. Complete, ready to play, with Moving-coil Speaker. In Walnut Cabinet. Cash Price, Carriage Paid, £15/15/0. Balance in 17 monthly payments of 20/-. **Send 20/- only**

**PYE "G."** 3 Valve with Band-Pass Tuning. Variable-Mu, Power-Grid and Pentode. Complete ready to play with Moving-Coil Speaker. Walnut Cabinet. Cash Price, Carriage Paid, £18/18/0. Balance in 17 monthly payments of 24/3. **Send 24/3 only**

**THIS YEAR'S WINNER**

**LISSEN "SKYSCRAPER"**

**COMPLETE WITH VALVES S.G.3 CHASSIS KIT CABINET KIT**

with (Lissen) S.G., Detector and Pentode Valves. Cash Price, Carriage Paid, £4/9/6. Delivered, carriage paid, on first payment of **8/3** Balance in 11 monthly payments of 8/3.

with (Lissen) Valves, Walnut Cabinet and special Balanced Armature Loud-speaker. Cash Price, Carriage Paid, £6/5/0. Delivered, carriage paid, on first payment of **11/6** Balance in 11 monthly payments of 11/6.

**ONLY FROM PETO-SCOTT ON GENEROUS EASY TERMS**

*Carriage paid to your door*

**BLUE SPOT PICK-UP.** With arm, rotating head and volume control. Cash Price, £3/3/0. Carriage Paid. Balance in 11 monthly payments of 5/9. **Send 5/9 only**

**MARGONIPHONE PICK-UP K.17.** With counter balanced arm and rotating head. Cash Price, £2/2/0. Carriage Paid. Balance in 7 monthly payments of 5/9. **Send 5/9 only**

**AERODYNE SCREENED GRID 3.** With Variable-Mu. Complete and ready to play with valves, batteries and accumulator with moving-coil speaker. Cash Price, £9/9/0. Carr. Paid. Balance in 14 monthly payments of 14/3. **Send 14/3 only**

**AERODYNE ALL-MAINS VARIABLE-MU S.G.3.** Complete and ready to play, with moving-coil speaker. Cash Price, £15/15/0. Carriage Paid. Balance in 17 monthly payments of 20/-. **Send 20/- only**

**IMPORTANT.** First with Radio on Easy Terms, we shall be pleased to quote you by return for all your Radio Requirements. We carry stocks of all leading manufacturers' Products advertised in this journal. Any parcel of components or accessories over £2 supplied on Easy Terms. Send for 1933 CATALOGUE

**PETO-SCOTT CO., Ltd., 77, City Road, London, E.C.1.**  
Telephone: Clerkenwell 9406/7.

West End Showrooms: 62, High Holborn, London, W.C.2. Telephone: Holborn 3248.

Dear Sirs, Please send me CASH/C.O.D./H.P. for which I enclose £..... d. CASH/H.P. Deposit. Also send you FREE 1933 Radio Catalogue.

NAME .....

ADDRESS .....

Pr.W. 10/12/32

**STRICT PRIVACY GUARANTEED — WE DEAL WITH YOU DIRECT**



**"FIVE POUNDS! Now I can build you a real quality set!"**

"I'd no idea that Bulgin made such an excellent kit of their components.

"This must be that attractive little set you remarked about when we fetched the accumulator last night. We'll go round to-night and hear it fully demonstrated."

Reader, have you heard it? It's the most amazing little set you can possibly make up. Only two valves, it's most economical of H.T. (average 10-12 mA.), but because its quality components are carefully matched it easily gives the results of a three-valve set. Primarily a local station set, it will also receive, on its own speaker, Radio Paris and many foreign stations, with splendid fidelity of tone.

Hear it to-night at your dealers, or write for descriptive folder 'N'



## 'SIMPLE TWO-THREE' (BATTERY DRIVEN) KIT

**A. F. BULGIN & CO., LTD.,** Abbey Road,  
BARKING, ESSEX.

Telephone: Grangewood 3266-3267.

London Showrooms: 9, 10, 11, Cursitor Street, Chancery Lane, E.C.4.

Telephone: Holborn 2072.

## THIS GUARANTEED KIT INCLUDES.,

- 1 BULGIN "TRANSCOUPLER"
- 1 BULGIN NEW SCREENED COIL
- 1 BULGIN D.P. ROTARY SWITCH
- 2 BULGIN VALVEHOLDERS
- 1 BULGIN DIFF. CONDENSER
- 1 BULGIN SCREENED H.F. CHOKE
- 1 BULGIN FUSE HOLDER & FUSE
- 1 BULGIN 3-POINT SWITCH

Bulgin Terminals, Battery Clip, Battery Cord, Grid Leak and Holder, Fixed Condenser, Brackets and Coils of "Quickwyre," ALSO Slow Drive Variable Condenser with Escutcheon Plate, Screws, Bolts, etc.

AND

POLISHED WALNUT CABINET with first-class Permanent Magnet MOVING COIL SPEAKER.

Full size Diagram and Layout.

Our complete Free technical service is yours to command, to ensure perfect results.

## EVERYTHING OF THE BEST!



**£5**

INCLUDES  
MOVING COIL  
SPEAKER and  
HANDSOME  
CABINET



Obtainable from ALL Dealers.  
In cases of difficulty write direct.

START COLLECTING OUR WEEKLY DATA SHEETS. SEE ANNOUNCEMENT BELOW!



**EDITOR:**  
Vol. 1. No. 12. || F. J. CAMM || Dec. 10th, 1932.

**Technical Staff:**  
H. J. Barton Chapple, Wh.Sch., B.Sc. (Hons.), A.M.I.E.E.  
Frank Preston, F.R.A., W. J. Delaney, W. B. Richardson.

## ROUND *the* WORLD of WIRELESS

### SPECIAL NOTICE!

#### OUR FREE WEEKLY DATA SHEETS

Starting with next week's issue we shall present FREE with every copy of PRACTICAL WIRELESS a Valuable Data Sheet, conveniently punched so that it may be filed for easy reference. One of these data sheets will be given every week until further notice, and each will deal with one special branch of wireless construction and operation. The first sheet, to be given next week, will deal with Accumulator Charging at Home, and it contains tables and illustrations covering both A.C. and D.C. charging. Other subjects to be covered are: Coils and Coil Winding, Mains Transformers, Resistances, Condensers, etc., etc. Each card is printed on a stout and serviceable manilla board, and will provide in At-a-Glance form all those elusive facts and figures which you are constantly needing when making or operating sets. This is the very first time that any paper has provided for its readers such a remarkable series of loose inset data sheets, and it is just one more index of the fact that this paper exists to serve its readers. You have nothing to do, for these data sheets are included loose in the issues. The enormous success of the paper, however, renders it doubly necessary for you to place a regular order with your news-agent.

#### Finland's Transmitters

FINLAND possesses eight broadcasting stations which are on the air daily, namely: Lahti (40 kW.), Helsinki (10 kW.), Viipuri (10 kW.), Oulu (1.2 kW.), Tampere (0.7 kW.), Turku, Pori and Jakobstad. Transmissions are made in both the Finnish and Swedish languages.

#### First Ultra Short-wave Station

ACCORDING to the *Osservatore Romano* (Rome), the Vatican station is being equipped with transmitting apparatus for broadcasts on a 60-centimetre wave, on the Marconi principle. It is the first station of its kind to be installed. A twin transmitter and receiver is also being erected at the Papal Palace

at Castelgandolfo for a regular telegraphic and telephonic service with the Italian capital.

#### New Stations in Hungary

WORK on the new 150-kilowatt Budapest (Hungary) transmitter has progressed so satisfactorily that it is fully expected to get it ready for operation by the spring of 1933. In the meantime, four relays of lower power are being opened at Magyarovar, Nyiregyhaza, Miskole and Pecs; they will work on 210 metres.

transmitter specially erected for the purpose, and re-broadcast through the entire National and Columbia Broadcasting Systems. As the transmission will also be taken by the W8XK and W3XAU group of stations on short waves they will be accessible to listeners in the British Isles.

#### The Witzleben Radio Tower

THE Berlin radio authorities are contemplating immediate alterations to the uppermost platform of the Witzleben aerial tower as recently a man, in order to test a new parachute, threw himself from that high point with fatal results. Similar attempts were made from the Eiffel Tower, Paris, some years ago.

#### European Concert

ON March 3rd next, Switzerland will broadcast an International Concert in which the Zurich, Berne, Basle, Geneva, Lausanne and Lugano studios will take part. The transmission will be relayed by land-line to the main European stations.

#### To Broadcast Without Permit

NOTWITHSTANDING emphatic protests lodged by local Municipalities, the French authorities refuse to sanction the opening of the new 60-kilowatt station built by Radio-Toulousc. On the other hand, it is now stated that, in accordance with the Ferrié plan for the reorganization of the French broadcasting system, a 120-kilowatt station is to be erected by the State in that district. In the meantime, Radio-Toulousc may be heard testing after midnight.

#### A Station with a Tragic Name

THE inhabitants of Sarajevo (Yugoslavia) have appealed to the government authorities to allow them to take over the military wireless transmitter in that city and to convert it to telephony. If this plan is carried out the station will act as relay to Belgrade, Ljubljana and Zagreb.

#### Too Much of a Good Thing

RUMANIA has protested against the power of the Leipzig broadcasts which, although on a channel 9 kilo-

The Editor  
and Staff Join  
in Wishing  
Every Reader  
a Very  
Happy Christmas

#### Some S.B.!

IN celebration of the fifteenth anniversary of the Soviet Republic in Russia, relays were carried out by the Moscow and Leningrad stations from every studio in the land, including broadcasts from the Island of Kolhujev; the most northern post at Severnaja Zemeja, and even greetings from Franz Josephsland. Many of these transmissions were carried out by wireless link.

#### Listen to Chicago

THE official opening of the forthcoming International Exhibition at Chicago (Ill.) will be relayed to a new short-wave

# ROUND *the* WORLD of WIRELESS (Continued)

cycles from the Bucharest wavelength, completely cover the latter's transmissions, even in the neighbourhood of the capital. A request has been lodged with the *Union Internationale de Radiodiffusion* at Geneva to obtain a channel less liable to interference.

## Back to the Army Again

**T**HROUGHOUT Germany listeners are signing petition lists to be sent to the Reichsfunk at Berlin, with a view to an alteration in the character of the radio programmes. Complaints are made that since the transfer of the studios to the State, the broadcasts are too subject to a military influence.

## A Multi-Lingual Broadcaster

**O**F all the European stations Moscow (Trades' Unions) is the one which transmits in the greatest number of languages. For the remainder of this month on both 1,304 and 50 metres talks will be given in French and English (8.0—9.0 p.m.); Swedish, Magyar and Spanish (9.0—10.0 p.m.); and earlier in the evening, between 7.0 and 8.0 p.m. G.M.T., in German, Dutch and Czech.

## Transatlantic Opera via Berlin

**D**URING the coming winter season relays of performances from the Metropolitan Opera House, New York, will be broadcast by a number of German stations. They will be picked up on short wavelengths at Beelitz, near Berlin, and from there fed to the transmitters through the usual landlines.

## More Power for Holland

**T**HE increased output of the Hilversum transmitter having proved its value to Dutch and foreign listeners steps are to be taken to reconstruct the Huizen broadcasting station in order to boost its power to 20 kilowatts. The station works daily on 1,875 metres.

## Where the Nuts Come From

**T**HE Anglo-Brazilian wireless telephone service has been extended to cover the State of Minas Geraes. The cost of a call from London is £6—for the first three minutes and a supplementary £2 for each subsequent minute. An effective cure for stammering!

## The Ultra-ultra Short Waves

**E**XPERIMENTS are being carried out by the Air Ministry with a micro-ray equipment in connection with the cross-channel air services. Tests are to be made on wavelengths in the neighbourhood of fifteen centimetres. Special apparatus for the purpose has been installed at Lympno airport to establish two-way communication with the St. Inglevert Aerodrome near Calais (France). In connection with these experiments teleprinters for the automatic transcription of messages will be brought into operation.

## Belgium and The Congo

**B**ETWEEN 10.0 and 11.0 a.m. daily an interchange of messages is carried out by the Ruyssedele (Belgium) radio station and Leopoldville (Congo) on 19.3 m.; at night towards 11.0 p.m. G.M.T. the wavelength is changed

## INTERESTING and TOPICAL PARAGRAPHS

over to 42.1 m. The tests are made in clear telephony.

## How They Work in the U.S.A.

**N**OW that so many transmissions are being heard on the medium waveband in the late hours of the night it may interest

you to know that the studios place their entertainments under two headings, namely, "Sustaining programmes" and "sponsored programmes." The first are those of which the station owners pay the cost, the latter the "time" sold to private concerns for publicity and advertising purposes. Most of the main stations are on the air eighteen hours a day.

## Hourly Weather Reports

**N**O motorist who has a wireless set need be fog-bound. Official Air Ministry weather reports are broadcast on a wavelength of 833 metres roughly at hourly intervals throughout the morning and the late afternoon from the A.A. radio station at Heston airport. It is the only station of its kind in the country, and the reports have proved invaluable to motorists, airmen and also to farmers, many of whom now regularly tune in. On a flight south from Newcastle during a recent spell of very bad weather an aeroplane was able to complete the journey in a few hours with the help of the weather reports, while a second machine was held up for 4½ days. The station, which is fitted with Exide batteries, has a range of 250 miles for broadcasting and considerably more for telegraphy—and thus covers almost the whole of England.

## Radio Receiver in a Royal Car

**T**HE PRINCE OF WALES has had one of his motor-cars specially equipped with a wireless set; it has been fitted under the footrest in the rear part of the saloon. The receiver contains an automatic volume control in order to maintain music and speech at an even strength as the car travels through streets screened by high buildings. The aerial is concealed in the roof. Two loud-speakers have been installed, one in the chauffeur's section to enable him to hear broadcasts whilst waiting for his Royal Master.

## Far North Radio Station Destroyed

**A** REPORT has reached Copenhagen from Greenland to the effect that the wireless station OXM, Scoresby Sund was burnt down at the beginning of last September. The news caused some anxiety in regard to the difficulty which might be experienced in keeping in touch with the British Arctic Air Route Expedition, but it is stated that communications from its members would be sent through Angmagssalik (OZL). These stations are solely used for wireless telegraphy and operate on 600 and 975 metres.

## Don't Shoot the Pianist!

**A**T the Bucarest studio, a special glass cage has been built for the conductor of the orchestra; it enables him, whilst in full view of the musicians, to hear through a loud-speaker how the concert reaches the ordinary listener.

## AIRWAY RADIO STATION



This is the U.S. Department of Commerce new aviation radio station on the high slopes of the San Gabriel Mountains at Glendale, California. From here hourly broadcasts of weather along California airways are sent out for benefit of aviators in the air.

## SOLVE THIS!

### Problem No. 12.

Rogerson owned a Portable set, and was not satisfied with the reception of foreign stations. He therefore decided to work the set with an outside aerial, and accordingly fitted a six-pin coil holder in the cabinet, and joined the frame aerial in series with the coil. When the outside aerial was attached he found he could not tune to any of the ordinary broadcasting stations, and in fact could only just hear Radio-Paris on the zero setting of the tuning dial. Why was this? Three books will be awarded for the first three correct solutions opened. Mark envelopes Problem No. 12, and send to the Editor, PRACTICAL WIRELESS, Geo. Newnes, Ltd., 8-11, Southampton Street, Strand, London, W.C.2, to reach us not later than December 12th.

### SOLUTION TO PROBLEM No. 11.

Jameson overlooked the fact that the secondary of the transformer required a centre-tap in order to apply grid bias to the output valves. The following three readers receive books in connection with Problem No. 10: Mr. John Owens, 9, Clayton Street, Dudley, Northumberland; Mr. Charles Myers, 7, Woodville Road, New Barnet, Hants.; Mr. R. Gill, Old Farm House, Grand Bouet, Guernsey, C.I.

## FREE NEXT WEEK!

NO. 1 OF OUR SERIES OF  
**DATA SHEETS**

SEE PAGE  
577.

# A QUICKLY-MADE GRAMOPHONE AMPLIFIER

FOR those who do not possess a radio-gramophone this little amplifier may be quickly made up for the Christmas holidays for providing dance music. It is assumed, of course, that the use of a pick-up with the ordinary wireless receiver is not possible for some reason or other, and that, therefore, a separate amplifier is

needed. No cabinet will be needed unless the amplifier is to be kept as a permanent piece of apparatus. Fig. 1 shows the circuit diagram, and Fig. 2 the wiring diagram. It will be seen that the very simplest layout is required, only two valve-holders and a transformer being used. Where it is thought necessary, a terminal strip can be attached to the back of the base-board and an on-off switch may also be fitted to the panel to provide a ready means of switching off the valves. The total cost of the components, therefore, will be under £1, to which must be added the two valves and batteries. The first valve should be of the L.F. type, and the second a small power valve. The transformer is a Lissen Hypernik, and this, with the two valves mentioned, will give a really good output. The pick-up should be fitted with a volume control, but if this is one of the types which is not provided with such a control, a potentiometer should be mounted on the panel as shown in dotted lines. The value of this component will depend upon the make of pick-up employed, and the maker's instructions should be followed in this instance. If an ordinary table model gramophone is being employed, a pick-up without carrier

arm should be obtained, and this may be plugged into the tone-arm in place of the present acoustic soundbox. Where a complete piece of apparatus is being constructed, however, obtain a pick-up with carrier arm complete, and it will be certain to be correctly tracked. H.T. 1 should be plugged into the 100-volt tapping and H.T. 2 into a voltage from 120 to 150 volts. Remember that the higher the voltage the louder the output can be without distortion. The value of the grid bias will depend upon the valve maker's instructions and care should be taken that these are adhered to. For normal entertainment purposes, such as songs, records of speech and such-like, this amplifier will give ample volume. For dancing, however, a much more powerful scheme must be employed, and in place of the power valve it would be advisable

to employ two valves in push-pull. The transformer in this case would have to be one of the special push-pull transformers, and a special push-pull output transformer would also be required. In addition, a further valve-holder would be required for the extra valve. The first valve in

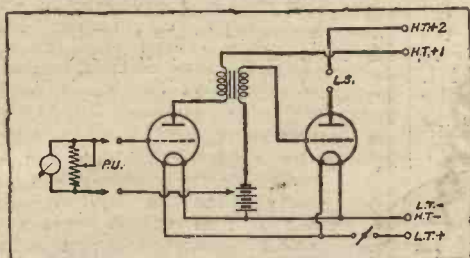

Fig. 1.—Theoretical circuit of the gramophone amplifier.

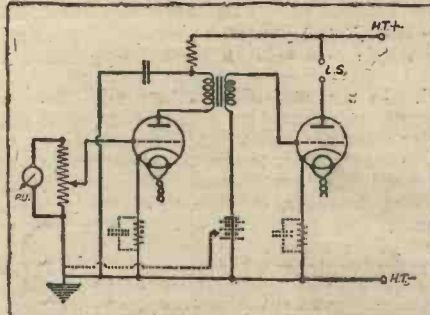

Fig. 3.—Theoretical circuit of the mains version.

needed. No cabinet will be needed unless the amplifier is to be kept as a permanent piece of apparatus. Fig. 1 shows the circuit diagram, and Fig. 2 the wiring diagram. It will be seen that the very simplest layout is required, only two valve-holders and a transformer being used. Where it is thought necessary, a terminal strip can be attached to the back of the base-board and an on-off switch may also be fitted to the panel to provide a ready means of switching off the valves. The total cost of the components, therefore, will be under £1, to which must be added the two valves and batteries. The first valve should be of the L.F. type, and the second a small power valve. The transformer is a Lissen Hypernik, and this, with the two valves mentioned, will give a really good output. The pick-up should be fitted with a volume control, but if this is one of the types which is not provided with such a control, a potentiometer should be mounted on the panel as shown in dotted lines. The value of this component will depend upon the make of pick-up employed, and the maker's instructions should be followed in this instance. If an ordinary table model gramophone is being employed, a pick-up without carrier

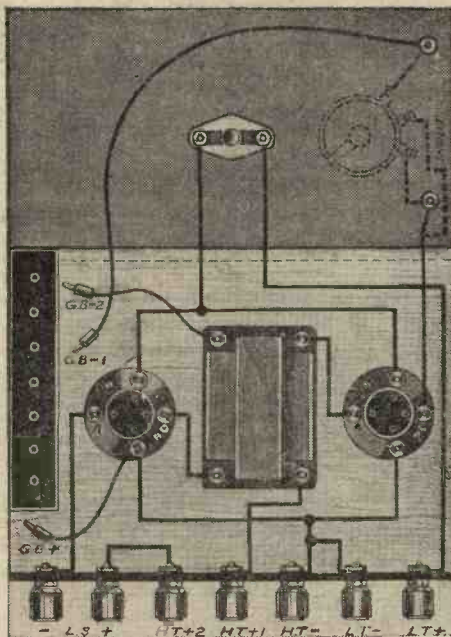

Fig. 2.—Wiring diagram of the two-valve gramophone amplifier.

this case could be one with a much higher amplification factor, and the H.T. could be increased.

This amplifier is intended primarily as a seasonable emergency and not for regular use, and therefore no actual measurements or other details are given.

Where it is desired to employ mains valves, the modifications necessary are simply in the fitting of 5-pin valve-holders and adjustment of grid bias. The extra pin is wired to earth (that is, H.T.—) and the grid bias may be provided as shown in the dotted lines. If automatic bias is required, the appropriate value of resistance, shunted by a 2 mfd. condenser, should be inserted in the cathode leads as shown. In this case remember that the output from the mains unit must be sufficient to supply anode voltage plus bias voltage. Only one H.T. tapping need be employed, a decoupling resistance being inserted in the first anode circuit to drop the voltage and to ensure stability.

See Photogravure Supplement in this issue for details of using a pick-up.

# Deriving Power from the Mains

An Article Giving Preliminary Notes on Working Sets from the Ordinary Electric-light Current

By GILBERT E. TWINING

ONE of the chief advantages of obtaining the high tension, and possibly the low tension, from the mains for operating the set, is the ability to have a non-varying constant supply always at

light mains. Eliminators may also be obtained, incorporating what is known as a trickle charger; this will maintain the L.T. accumulator of the set constantly charged ready for use. It is possible for the home constructor to build his own eliminator from components and materials purchased. Instructive articles are being published in this journal from time to time, dealing with this subject.

When changing over to mains operation with the existing set, it is advisable, if one is not already incorporated, to fit an output filter of some form or another, especially if the speaker is worked away from the set, for this will isolate the latter from the anode current and prevent a shock being received if the terminals on the set are accidentally touched; it will also help to stabilize the set and cut out any tendency to hum. This

### Changing to A.C. Valves

In changing to alternating current valves the supply from the mains has to be transformed down to the correct filament voltage, namely, 4 volts. If an eliminator is used for the H.T., which has no 4-volt tapping, it will be necessary to obtain a filament transformer of good manufacture, one side of which is connected to the mains, the other to the valve-holders. If a complete mains unit is being constructed, however, a transformer incorporating all the necessary windings, both H.T. and L.T., should be purchased, care being taken to select one of first-class manufacture by a well-known firm.

The valve-holders, of course, have to be changed to the 5-pin type, on account of the A.C. valves having an extra central pin, which pin is joined to the cathode. In Figs. 1 and 2 are shown the filament transformer connected to the valve-holder, also the extra terminal from the cathode is shown coupled to H.T. negative. Separate heater wires from the transformer, that is to say, filament leads, to the valve-holders, are recommended, and ordinary house lighting flex is quite suitable, in fact, it is preferable, for it reduces the possibility of mains hum, especially if the flex is taken beneath the screened baseboard and brought through holes drilled near to the valve-holders.

### Grid Bias

Most mains sets of to-day utilize part of the rectified H.T. supply for grid bias; this is obtained by the insertion of a resistance connected between the cathode and the centre tap of the filament winding in the trans-

former, which is connected to high-tension negative, see Fig. 3. It should be noted that the bias resistance is really across the high-tension supply, since one end goes to H.T. negative and the other end goes through the resistance of the valve to high-tension positive. The current flowing through the bias resistance will depend upon the current flowing in the anode circuit of the valve.

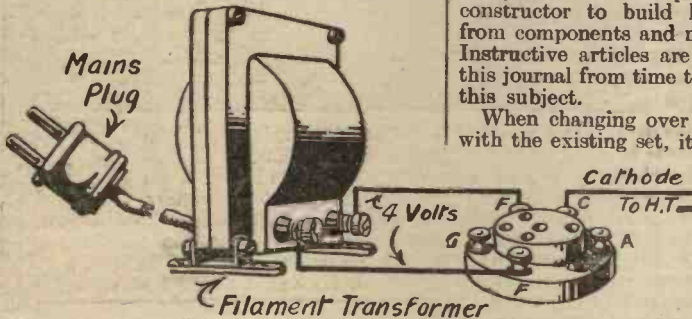

Fig. 1.—Pictorial diagram showing the transforming down of the mains supply to 4 volts for the indirectly-heated A.C. valve filaments.

hand. In the case of a battery set, low-tension accumulators have to be charged at regular intervals and, unless the owner has a spare accumulator to use, the set has to lie idle until it is returned. High-tension batteries, however, are the chief expense, for, periodically, they have to be renewed. One of the great disadvantages of using batteries is that immediately the set is switched on they commence discharging and running down, therefore, a good, constant current for an indefinite period is impossible. The owner who appreciates quality will never be quite satisfied that he is getting the best possible results from the set; he will always be juggling with grid bias and altering the wander plugs on the H.T. battery, endeavouring to improve the reception.

But with the all-mains set, where the anode current to the valves and the low-tension filament current are obtained from the mains which, as before stated, is constant, the owner knows that he has an indefinite period over which the set will give the same high quality of reproduction. It is a fact that an all-electric set is easy to maintain, and not only this, it is cheaper to run than the battery-operated set, for the cost of the electric current consumed is negligible, only running into a few shillings a year.

Alternating current is cheaper to operate from than D.C., i.e., direct current, the latter costing about twice as much when spread over a year; even then it is more economical than batteries.

If the expense of rebuilding the set, and turning it entirely into an all-mains receiver is considered too great, then the only thing to do is to instal an H.T. eliminator, retaining the L.T. and G.B. batteries and merely doing away with the high-tension.

### Eliminators for A.C. Supply.

Eliminators, as the name portrays, eliminate the H.T. battery, enabling the existing set to be connected to the electric

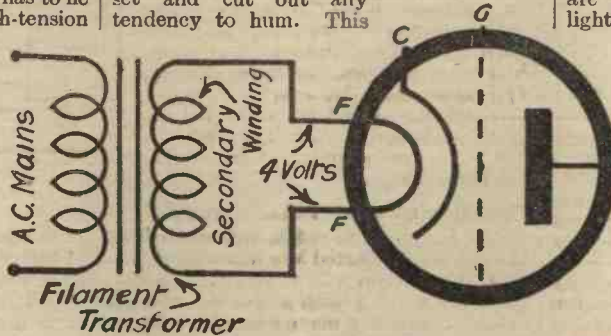

Fig. 2.—Theoretical form of Fig. 1.

system of installing an eliminator is beneficial in that the quality of the set will remain the same, and never fall off, and distortion commence as in the case with a set having an H.T. battery nearing the end of its life. It must be emphasized, though, that 4-volt A.C. valves are much more efficient than the battery type, due to their robust filaments. The great advantage of using the mains, together with mains valves, is that unlimited power without distortion is available. For this reason the complete all-mains driven receiver is greatly superior to a battery set, even if the battery set derives its H.T. from an eliminator.

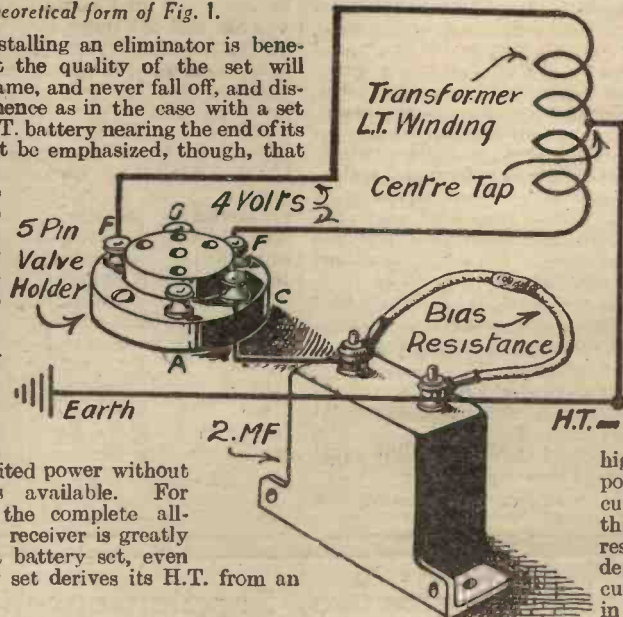

Fig. 3.—Utilising the rectified H.T. for automatic grid bias when operating from the mains.

# Loud-speakers Out of Focus

A Musician's View on  
Quality Reproduction

By RUDY STARITA

THAT listeners of the future will derive most of their musical education from the radio is certain. Young people of to-day are not learning to play the piano or violin as once was an almost routine accomplishment. Wireless and the gramophone are slowly displacing personal playing. And why attend performances of musical celebrities when they can be heard in our own homes? There is no answer, if radio brings to us a real replica of the original.

Unfortunately, between listening to an orchestra or soloist over the wireless, and hearing the same music in the concert room or studio, there is usually rather a wide difference which few radio experimenters seem able to probe. It is more disturbing to notice that some listeners appear to have settled down to inferior reproduction, and in many cases are unconscious of its unreality. Could you transport a symphony orchestra from the B.B.C. studio into your drawing-room, and manage to get them and all their instruments in, the volume of sound produced would be insufferable if they played as they do at Broadcasting House. It is evident that reproduction of an orchestra or band in your home must necessarily be at a considerably lower level of volume than would be heard by a person having a seat in the studio.

#### Elusive Lower Notes

Facsimile reproduction of an orchestra at its true volume is possible, of course, and is done in cinemas and dance halls. But in the home, anything approaching the actual volume would be decidedly uncomfortable, not only to you, but to your neighbours. At home we listen by radio to what may be termed a miniature of the music broadcast. It is like hearing an orchestra at a distance. But if you do that in actual fact, you will notice, as you go further away, and the general volume grows less, that the lower notes soon become fainter than the high notes. At a certain critical distance the orchestra becomes quite unbalanced, for the bass notes are now scarcely audible, whilst the higher ones still seem to carry well.

No matter how perfect may be the tonal balance of an orchestra as it plays in the studio, when it is reproduced in a listener's home at considerably reduced volume, the musical proportions are distorted—unless steps are taken to prevent it. This phenomenon is clearly observable when a band broadcast is being "faded-out." Listen, for instance, to the B.B.C. Dance Orchestra playing its signature tune at the end of a performance. At first you may hear the drums, piano and the other rhythmic ingredients. But just before it has faded away none of the bass can be heard at all. You can only distinguish the tenor saxophone, and the high staccato notes of the xylophone.

Another proof is to turn down the volume control of your set

when a band is playing. You will find infallibly that the lower notes disappear first. Now, as you are always listening to broadcast music at lower than actual volume, it is obvious that you are always hearing a somewhat unbalanced reproduction. Your set, so to speak, is permanently out of focus, although really our ears are to blame, for they are not by any means the perfect instruments we often assume them to be.

#### The "Straight-line" Characteristic

Radio set designers have, for many years, made strenuous efforts to confer upon receivers as a whole, and upon the principal components what is termed a "straight-line" characteristic. They are still trying to achieve an absolutely equal response from the loud-speaker all along the musical scale. But, except in large halls, cinemas and other circumstances in which life-like volume is possible, I am suggesting that this ideal is illusory and musically is definitely untenable. Sets should be designed so that the listener experiences the sensation of perfectly balanced music, as it is broadcast, and when the over-all volume is reduced, as invariably it is in an ordinary home, what the listener's ear interprets as proportionately weaker must be over-amplified so that a correct balance, as it appears to the ear, is retained. In practice this means that the usual home listener's set should not have a "straight-line" frequency response, but should definitely over-amplify the bass, when receiving music.

#### Tone-discriminating Volume Control

If it is desired to reduce volume further, this should be effected by a tone-discriminating volume control. I recently heard a set incorporating such a device, and was delighted with the manner in which perfect balance was maintained even when the volume was cut down to a whisper. The volume control proper consisted of a potentiometer controlling the screen-grid volts in the H.F. stage of the set, whilst the tone adjustment was a second potentiometer connected to one of the variable-tone L.F. transformers recently put on the market. The two resistances were ganged, mounted on the same shaft and controlled by one knob, so that as volume was reduced, the proportion of bass was automatically increased. Thus was the music kept in focus all the time.

Speech from the average loud-speaker is just as much out of focus, but in a different way. Even from a small set, reproduction of the radio announcer reading, say, the news bulletin is usually well above the actual level. If the announcer himself were standing in your room in place of the speaker he would not sound so loud. The receiver may amplify evenly all over the scale, theoretically, but when speech is reproduced above the natural level of loudness it appears to the ear very much stronger in the lower register. Again it is a trick of the ear, and it causes the announcer to talk from most loud-speakers in an unnaturally deep and gruff voice, which is not always quite clear.



Walk into the garden, and, although you can hear him through the open window, you cannot always make out what he is saying.

There are two easy remedies for this type of distortion. The best one is to reduce the volume level until the voice is of about the same intensity as an ordinary speaker in the room. But if greater volume is required, as is usually the case, then the low notes must be partially suppressed. A convenient way of doing this, if a choke and condenser output filter is used, is to arrange two condensers in parallel, one about the usual 2 mfd. and the other of .5 mfd., in place of the one condenser normally employed. When music is being received both condensers are in circuit, but for better reception of speech above natural volume the 2 mfd. condenser is shorted by a switch. It will then be found that a much bigger volume can be tolerated, and is quite comfortable, although at the same time, it is characterized by that crispness and brilliance of intonation which makes speech sound natural and understandable, even at considerable distances.

It seems possible to me that a tone-discriminating volume control for the reception of music and a special "speech switch" may become standard practice when it is more generally realized that radio music in the home is music in a cameo setting, and that we are reproducing the announcer or lecturer as through a megaphone. Then we shall have abandoned the illusion of being present in the studio, and struck out boldly for a new focussing of our loud-speakers, a change which, because it will make radio more real, will not only bring greater pleasure to us, but prove an invaluable aid in the musical education of the younger generation of listeners.

OUR FREE WEEKLY  
DATA SHEETS!

You Must Collect Them!

SEE SPECIAL ANNOUNCEMENT  
ON PAGE 577.

# MAKING A HIGH-FREQUENCY CHOKE

How to Make an Efficient Choke with Sectionalised Windings.

By A. W. THYNNE, A.M.I.R.E.

**H**IGH frequency chokes differ materially from the low-frequency type, inasmuch that they are wound on a core of non-magnetic material such as ebonite, paxolin or wood, whereas the latter possess a core of iron. By virtue of this, the construction of the former variety is rendered a comparatively simple matter. Although it is not intended to explain here the theory of the component, or to make any mathematical calculations, but to show how a typical example can be constructed, it is as well to mention that the high inductance necessary is obtained by employing a large number of turns of a fine gauge wire. Readers are no doubt familiar with their use and position in a circuit. First of all, then, a suitable former must be obtained, and made capable of carrying the large number of turns of wire necessary.

### Constructional Details

Take a round piece of ebonite or wood 3½ ins. long and ½ in. in diameter. With a scriber or other suitable tool mark off circles around the circumference of the bobbin at the distances apart shown in Fig. 1. The object in view is to cut out from the rod, grooves ½ in. long and ⅛ in. deep. See Fig. 2. If a lathe is available, this part of the job is not difficult. If not, as is probably the case with most constructors, proceed as follows.

Take an old file or any piece of metal which has at one end a face ½ in. wide, and bring it to a red heat in a fire, or on a gas-ring. With this tool the grooves can be burnt out quite satisfactorily. If wood is being used in the construction, however, it will be found that a sharp knife or chisel will do the job with less trouble. It is hardly necessary to mention that should the burning method be employed, it is advisable that it be performed near an open window to allow easy escape for any undesirable fumes. Having done this, take a hacksaw blade and make a diagonal cut ½ in. deep across each flange. See Fig. 2. This is to allow a free run for the wire when winding, to pass from one soldering groove to the next.

A suitable base is provided by cutting a piece of ebonite or wood 2½ ins. by 1 in. This should not be too thick, preferably 3/16 in. Drill a hole through the centre with a No. 26 drill, and countersink the underside. If ebonite is being used for the bobbin, drill a hole ½ in. deep with a No. 33 drill down the centre of the base end of the core. The base end as shown in Fig. 2 is the extremity with the ½ in. flange. Thread this hole with a 4BA tap. The base and former can now be screwed together with a ½ in. or 9/16 in. 4BA countersunk head brass bolt. In the case of wood the

base is screwed on with a countersunk head brass wood screw of the same length.

To fix the base terminal, drill (No. 33 drill) and tap (4BA) a hole in the bottom

tap a 4BA hole down the centre of the core in a similar manner to the base end. Screw into this a 4BA brass terminal, first inserting a soldering tag between the ebonite and metal. For the wooden arrangement, screw a 4BA soldering tag to the top centre of the core with a 4BA brass terminal having wood screw fixing. The wooden bobbin should now be shellac varnished, and the bottom of each groove lined with Empire cloth or very thin ebonite paper. To do this cut the material into lengths ½ in. by 1½ ins., and wind round the inside of the recess while the shellac is still in a sticky state.

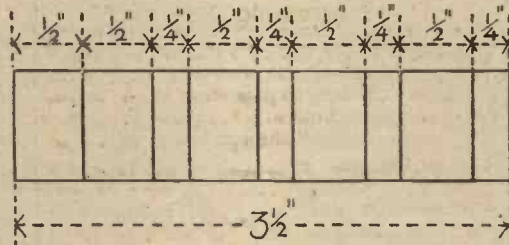

Fig. 1.—How to mark off the ebonite rod which forms the basis of the choke.

section of the choke former at the position shown in Fig. 3. Screw a 4BA brass terminal into the hole, first placing a 4BA soldering tag between the ebonite and brass. For

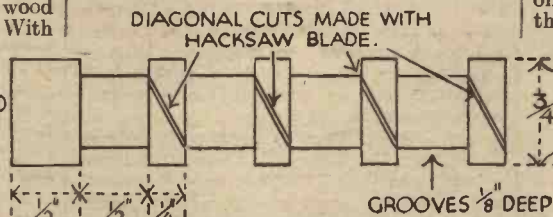

Fig. 2.—The finished ebonite former, ready for winding.

wood, screw a 4BA brass terminal with wood screw fixing into the flange, locating it in the same position as for the other material. Now turn attention to the other end, and, in the case of ebonite, drill and

### Winding the Bobbin

The bobbin is now ready for winding. Fig. 3 shows its general appearance at this stage. For the coil winding about half an ounce of No. 38 gauge double silk covered (D.S.C.) wire is required. Bare and tin one end, and solder it to the soldering tag on the top of the bobbin; slip the wire through the first hacksaw cut, and wind on 300 turns in the first groove. Neat and quick winding can be made if the end of the bobbin is fixed in the chuck-end of a geared hand drill, gripped horizontally in a vice. All that is then necessary is to turn the wheel with one hand and feed the turns on with the other.

If this method is employed, fix the bobbin in the chuck and make a mark on it with a piece of chalk or pencil, turn the wheel of the drill round one revolution and note the number of turns made by the ebonite. Divide this latter number into 300, and this will give the number of turns required on the hand wheel to ensure the requisite number of turns on the core. As an example, the writer found that for one revolution of the drill used four turns were made by the core, hence for every groove, seventy-five revolutions of the brace were necessary. Having wound on the first 300 turns, slip the wire through the next hacksaw cut into the second groove, and carry on winding in the same direction until another 300 turns are completed. Continue the process until all four recesses have 300 turns each. Bring the wire out through the last cut in the bottom flange, bare and tin the wire at the point and solder it to the soldering tag under the base terminal. The choke windings should now be shellac varnished. Baseboard fixing screw holes should be located at the discretion of the constructor to suit individual requirements.

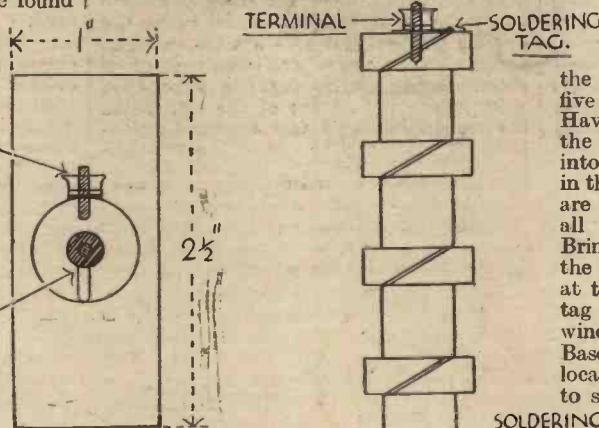

Fig. 3.—The method of mounting, and fitting the terminals.

FREE NEXT WEEK!

No. 1 of our

DATA SHEETS

SEE ANNOUNCEMENT ON PAGE 577.



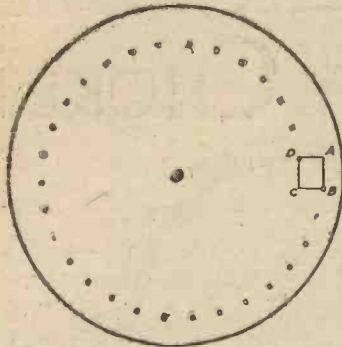

Fig. 1.—The disc used for scanning the image, showing the spiral arrangement of the holes.

# WHAT *is* TELEVISION?

## (PART 2)

### The Second Article of Mr. Barton Chapple's Interesting Series

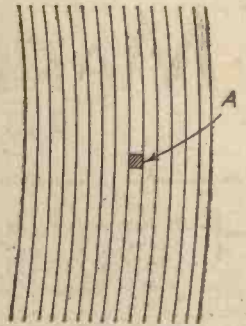

Fig. 2.—How the picture area becomes divided into a series of light sections.

SO much then for the introduction of television in its broadest sense, let us now get down more to details and deal step by step with the individual stages of transformation that take place in a television system. For studio or indoor scene working there are two types of machines which can be employed at the transmitting end, and these are known respectively as spot light disc and spot light mirror-drum transmitters. In the early English transmissions only the disc machine could be used, and although it was capable of producing exceedingly good results on close-up images (head and shoulders), it was not so adaptable to extended scenes (full length).

One of the main differences in the two machines is in the method of producing the resultant light spot movement. Dealing only briefly with the former (disc machine), since this is not employed so largely in the modern television studio, we have first of all a powerful source of light. In practice, this is either a specially designed metal filament lamp or an arc lamp. The light source is housed in a metal container provided with a truncated funnel at the front, while at the rear is a reflector to concentrate the rays down the funnel. As the resultant rectangular beam of light emerges from the funnel exit it plays upon a flat metal disc, purposely made heavy so that it acts as a flywheel and in this way tends to run at a constant speed.

#### The Disc Transmitter

The disc has a series of small square holes pierced through it near the outside edge and they are arranged in the form of a clockwise spiral as indicated in Fig. 1, where the rectangle ABCD is drawn to represent the light area thrown on to the disc face. The holes have equal angular displacements around the disc, the perforations being so arranged that the outer edge of one hole is on the same circumferential arc as the inner edge of the next hole, and so on all the way round. A correct positioning of the disc with reference to the rectangle of light playing on the disc surface

enables each hole to pass through the light as the disc revolves. A square beam is thereby "thrown" through every hole, and

light area on the back screen is dependent not only upon the distance between the lens and the screen, but also upon the difference between the distances of the first and last holes from the disc centre, and the distance between each hole in a circumferential direction. The diagram shown at Fig. 3 will convey to the reader a good impression of the scheme which has just been described, while one of the accompanying illustrations depicts a light spot disc transmitter used by Fernseh A.-G. in Germany.

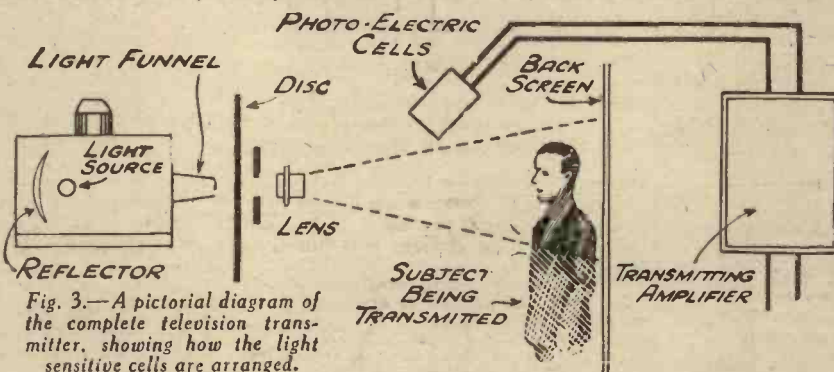

Fig. 3.—A pictorial diagram of the complete television transmitter, showing how the light sensitive cells are arranged.

if a screen is interposed in the path a definite shaped light area is built up somewhat as illustrated in Fig. 2.

#### The Mirror-drum Machine

So much then for the disc transmitter, let us now examine an up-to-date mirror-drum machine. In view of the present B.B.C. transmissions it is appropriate to describe the apparatus which has been made by the Baird Company and is installed in Studio BB of Broadcasting House for these transmissions.

This particular machine is shown in bare diagrammatic form in Fig. 4, while one or two photographs indicate it in good detail. First of all there is an arc light source which can be moved backwards and forwards on channelling in a metal casing by operating one of the levers seen in the photograph. Just in front of the arc lamp is a circular shield of metal with a small square hole cut in it, and this allows a square beam of light to pass through and be focused on an inclined mirror—see Fig. 4. The mirror reflects this beam on to a drum made of aluminium, purposely lightened by having sections cut away and having thirty mirrors positioned round its edge—see photographs. Each mirror seats itself in such a way that it is inclined at a slightly different angle to its immediate neighbour, with the result that as the drum revolves, the light projected on to each mirror is thrown as a spot on to any screen placed in its path, and this spot is made to move vertically from the bottom of the screen to the top. As each mirror takes charge of the spot of light it is made to create a strip of light, these individual strips joining together to produce a rectangular light area as indicated in Fig. 5. It will be seen that this area has parallel straight sides,

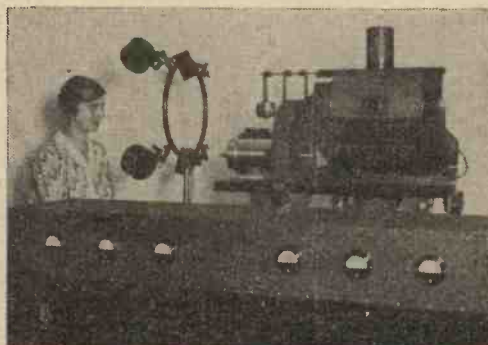

The photo-electric cells are held on the ring in front of the lady.

A suitable lens is included to enable the beam to be focused on the screen, and when the disc is stationary a clean cut square area of light is seen, such as A of Fig. 2. Naturally the actual size of the

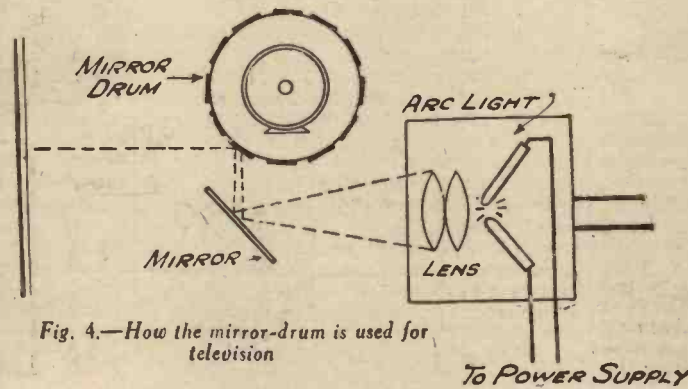

Fig. 4.—How the mirror-drum is used for television



Fig. 5.— The straightened picture are a resulting from a mirror-drum.

mechanism used in this connection is seen clearly in the photographs. Furthermore, it is possible to move the transmitter bodily on rails and also "swing it," and in this way to follow any movement of the artist being televised.

**The Baird System**

With the Baird system used by the B.B.C. the process of scanning (a point common to both types of transmitter) is carried out vertically, although on some parts of the Continent and the U.S.A. a preference is given to horizontal scanning. Referring once more to Figs. 2 and 5, it must be borne in mind that in the case of the English system the direction or rotation of the disc or mirror-drum and the positioning of the light source with reference to these rotating parts is such that the scanning operation starts in the bottom right-hand corner of the area. Each spot then moves from the bottom to the top of the light field as a strip and each strip is traced out on the left of its predecessor until one revolution is completed, when the process is repeated. This is an important point, for if not followed correctly confusion will arise later at the receiving end, so remember it in this form, *spot movement bottom to top and strip movement right to left.*

The spot or spots of light which create this effect carry out their work at a relatively rapid rate, namely, 750 revolutions in one minute, corresponding to twelve and a half complete explorations in one second. A small amount of flicker is noticed, but for all practical purposes one has the impression of a flood-lighted area when watching a television transmission take place.

So far, the schemes I have described are relatively simple, but I can picture the reader saying to himself that he fails to see any reason why a spot of light should be made to move over any scene or object rapidly, even if it does follow a pre-deter-

mined and definite geometrical path. Why make the spot move at all, or, alternatively, why not flood-light the scene and transmit it by television in its entirety just the same as you would take a photograph with the camera? Such conjectures are perfectly justified until one has made formal acquaintance with the conversion of light into electricity, one of the most important links which has to be forged in the television chain of events.

The first important discovery in connection with the conversion of light into electricity came about in rather a peculiar fashion. Many years ago a cable operator noticed that one of his instruments behaved in a very erratic manner every time a sun ray touched the resistances, which were made up from a metal called selenium. Investigations of the peculiar phenomenon were undertaken, and the fact that selenium was sensitive to light discovered. When the metal is connected up in a circuit and exposed to light an electrical current will flow in the circuit of which it forms a part, but on shielding the selenium from the light rays the current flow will cease.

**Discovery of the Photo-Electric Effect**

This discovery led scientists to believe that they had the solution of a means for

method of solving her television problem has formed the basis of many of the first television schemes. A clue to the solution of the problem is found in a close examination of the screen, which is called the retina. The surface of this is found to consist of a

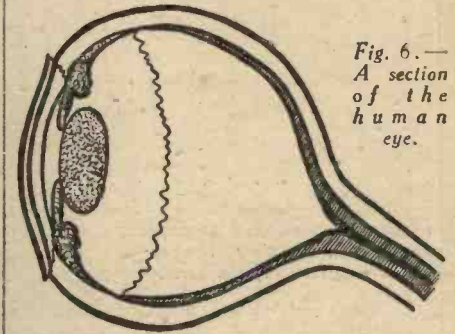
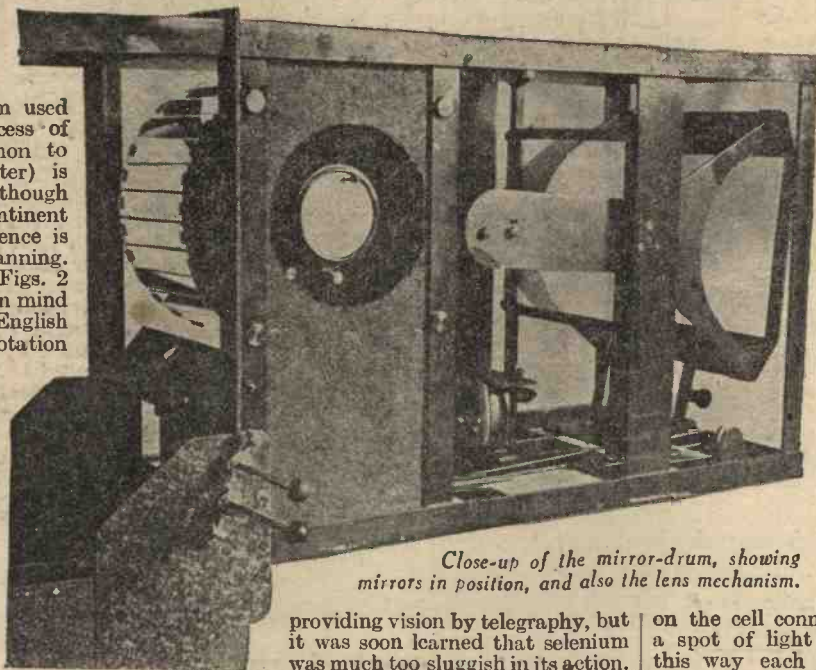

Fig. 6.— A section of the human eye.

mosaic made up of an enormous number of hexagonal cells, and each of these cells is directly connected to the brain by a number of nerve filaments along which travel impulses, which are dependent upon the intensity of the light falling on the hexagonal cell. Exactly how these impulses are generated is not at present fully understood, but they are almost certainly due to the presence of a light-sensitive substance named visual purple, which flows through the hexagonal cells. The images which we see are thus built up of an extremely fine mosaic of microscopic hexagons of varying degrees of light and shade. The number of these hexagonal cells is stupendous. In a normal human eye there are several millions.

The early inventors endeavoured to construct artificial eyes by substituting selenium for visual purple and building an artificial retina out of a mosaic of selenium cells, each of these cells being connected by wires to a shutter. This shutter opened when light fell



Close-up of the mirror-drum, showing mirrors in position, and also the lens mechanism.

providing vision by telegraphy, but it was soon learned that selenium was much too sluggish in its action. That is to say, the current responses to a change of light lagged behind, and high frequencies could not be handled. In 1888, however, the German, Hertz, discovered what is now known as the photo-electric effect, and constructed special cells working on this principle. These cells turn light into electricity, but another difficulty at once made its appearance. The cells, although they were fast enough, would not respond to the very small light available. Shadows could be sent, for with shadows the light from a powerful lamp can be directed straight on to the cell. But where television is concerned, only the light reflected from the scene is available, and this light is very small indeed. Inventors, therefore, endeavoured to simulate nature's television system as exemplified in the human eye, which is shown roughly in Fig. 6.

An image of the scene is cast by the lens on to the retina or screen. This image has to be conveyed to the brain, and nature's

on the cell connected with it and allowed a spot of light to fall on a screen. In this way each cell controlled a spot of light, the image being reproduced by a mosaic formed of these spots. Models on these lines were actually made by several inventors, but the thousands of cells, shutters and wires necessary made the practical adaptation of such schemes out of the question, and an endeavour was made to solve the problem in the manner I originally started to outline.

Coming back to our photo-electric cells, which have now been developed to a very advanced degree of perfection, it must be remembered that these cells turn light into electricity, and although only a minute current flows they are, for all practical purposes, instantaneous in action, a quality which television demands for its successful accomplishment, and the small current response is easily made good by suitable valve amplifiers.

A SPECIAL ANNOUNCEMENT OF INTEREST TO YOU APPEARS ON PAGE 577

To-day's greatest value in

de luxe **ALL-ELECTRIC RADIO**

**£17.17s**

**TWO VARIABLE-MU  
SCREENED GRID  
H. F. STAGES**



GRADED VOLUME CONTROL

MAINS ENERGISED MOVING COIL LOUD SPEAKER

ILLUMINATED TUNING DIAL CALIBRATED IN WAVE LENGTHS

ALTERNATIVE TONE SELECTOR

**ALL-ELECTRIC MODEL 533A**

Complete receiver as illustrated above, in handsomely finished cabinet with five Cossor A. C. Mains Valves, Types M.V.S.G. (2 Metallised) 41 M.H. (Metallised) 41 M.X.P. and Rectifier 442 B.U. and built-in Cossor Utah Moving Coil Loud Speaker. Pick-Up Plug and Jack.

PRICE **£17.17**

Hire Purchase Terms: 60/- deposit and 12 monthly payments of 28/-.  
For A.C. Mains only 200/250 volts (adjustable), 40/100 cycles.

**D**UE to its two Variable-Mu Screened Grid stages this Cossor All-Electric Receiver has exceptional range and selectivity. Its performance is outstanding — far superior to similar Receivers having only one S.G. stage. Superb reproduction is provided by its

Mains Energised Moving Coil Loud Speaker. Fitted with every up-to-date refinement to ensure efficiency and ease of operation, this handsome Cossor Model represents remarkable value for money at its modest price of £17.17s.

To A. C. Cossor Ltd., Melody Dept., Highbury Grove, London, N.5.

Please send me free of charge the 16-page catalogue of Cossor Receivers B 16.

Name .....

Address .....

Prac. 10/12/32.

**COSSOR**  
*All-Electric* RECEIVER

With Moving Coil Loud Speaker  
**Model 533A**

**COSSOR RECEIVER**

**MODEL 732** (Battery Operated)

For those who prefer a Battery operated Set this model will meet the most exacting requirements in performance. Four-Valve receiver incorporating Two Variable-Mu Screened Grid Stages complete with two Cossor 220 V.S.G., Cossor 210 H.L. and Cossor 220 P. Valves, in handsome oak cabinet with self-contained Loud Speaker, pick-up plug and socket.

PRICE **£12.15**

Hire Purchase Terms: 35/- deposit and 11 monthly payments of 22/-.

(Prices do not apply in I.F.S.)

A. C. Cossor Ltd., Highbury Grove, London, N.5. Depots at Birmingham, Bristol, Glasgow, Leeds, Liverpool, Manchester, Newcastle, Sheffield, Belfast and Dublin.



*Graham Farish says*

# YOU CAN'T BE MORE CRITICAL THAN I AM

I don't know what tests you make of the Components you buy, but I do know that every one I sell is tested far more stringently before it leaves my factory. It has to be not only capable of doing the job for which it is designed—but it has to bear electrical stresses greater than will ever be required in practice before I allow it to bear my name. That is why you can trust every Graham Farish product to the limit.

## Graham Farish **SNAP** H.F. CHOKES

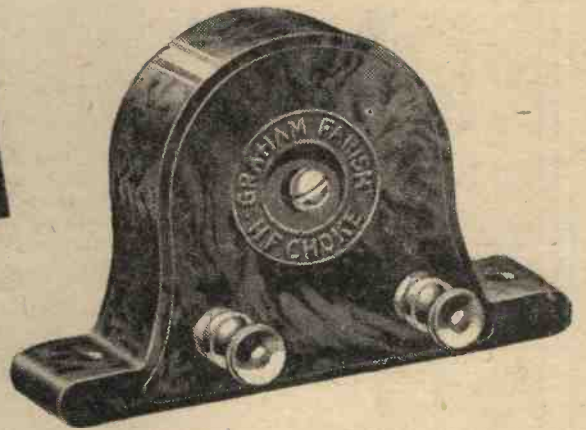

Of new design, wound to give high impedance on long and medium wave-bands. Has small self-capacity with large inductance. Totally enclosed in moulded case.

*Every Wireless Enthusiast should have a copy of the G.F. Component Book. Send a postcard request for your copy, free by return.*

**2/-**  
EACH

## Graham Farish **OHMITE** RESISTANCES

The popular and efficient resistances for all general purposes. All values 300 ohms to 5 megohms. 1/6d. each.



**BETTER THAN WIRE WOUND**

**1/6**  
EACH

To get the best from your Set—earth with **FILT.**

# GRAHAM FARISH COMPONENTS

GRAHAM FARISH LTD., MASONS HILL, BROMLEY, KENT.



**THE HALF-GUINEA PAGE**

# Radio Wrinkles FROM READERS

**A Useful Testing Device**

THIS little testing gadget which is simple to make, will be found very useful to wireless workers. Details of the

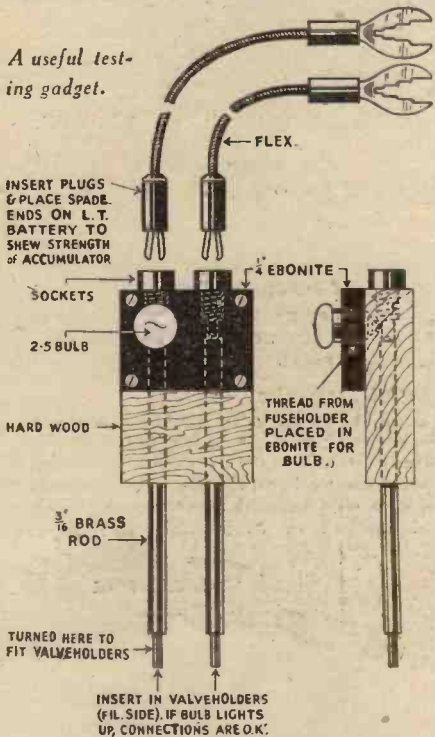

device will be clear from the accompanying sketch. The tester, if placed in a valveholder will denote when a new set has been wired up correctly, by switching on the filament current. The plugs and sockets at the other end, when connected together and placed on terminals of accumulator, will give an idea of the strength of battery. It is also useful for testing G.B. cells at valve holder ends. The holes in the wood block should be made so that the brass rods are a tight fit.—W. FRIEND (Shoreditch).

**A Cheap and Reliable Earth**

AN efficient earth plays an important part in the reception of a set, and many defects can be traced to a faulty earth. A very good and little-known earth can be made in a few minutes as follows: Procure a small syrup-tin, and pierce several small holes in the side and bottom. Fill with sal-ammoniac, make a hole in the lid through

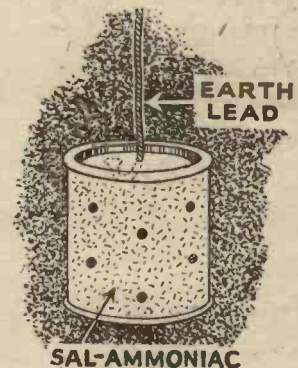

An efficient earth.

**THAT DODGE OF YOURS!**

Every reader of "PRACTICAL WIRELESS" must have originated some little dodge which would interest other readers. Why not pass it on to us? For every item published on this page we will pay half a guinea. The latest batch is published below. Turn that idea of yours to account by sending it in to us, addressed to the Editor, "PRACTICAL WIRELESS," George Newnes, Ltd., 8-11, Southampton Street, Strand, W.C.2. Put your name and address on every item. Please note that every notion sent in must be original. Mark envelopes "Radio Wrinkle."

which the earth wire is passed, and then solder on underneath. The whole is then buried about one foot in the ground. About two pennyworth of sal-ammoniac is sufficient.—A. PARTINGTON (Wigan).

**Protecting Metallized Valves**

MANY amateurs are probably taking the advice of the valve manufacturers and fitting new valves in their sets. Most of these valves are of the "metallised" type, and great care is, therefore, necessary when fitting, and subsequently "poking about" inside the set (probably left switched on) not to "blow" the whole set of valves via the filament circuit. A good "dodge" to lessen this risk as much as possible is as follows. An old bicycle inner tube is procured and after cutting to suitable length a piece is slipped over each valve, as shown in the sketch.—F. SYMONS (Newton Abbot).

**METALLISED VALVE**

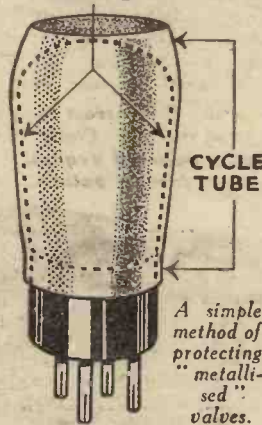

**A New Use for Spaghetti Resistances**

BEING short of cash and in need of a volume control, an idea occurred to me to use those handy resistances. All values can be made for a few pence. Take off the ends and carefully remove outer covering. The ends are held by nuts, the bolts are tapped into the ebonite. The wires which make the contact are short ends

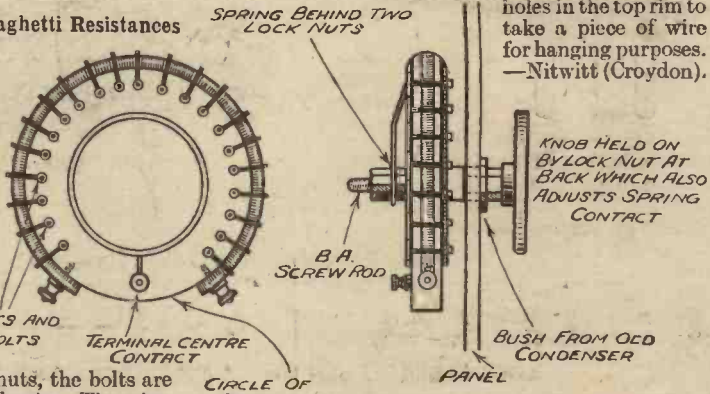

of Glazite with insulation removed, a loop being made in one end, and a bolt passed through the loop. Take wire over the resistance, twist round bolts and screw on nuts. You will find as the nut is tightened, it will pull into the element. Mine have pulled in and no damage was caused to the resistance. The action is smooth and will wear indefinitely. All the material can be found in the junk box.—W. E. SHARPEY (Maidstone).

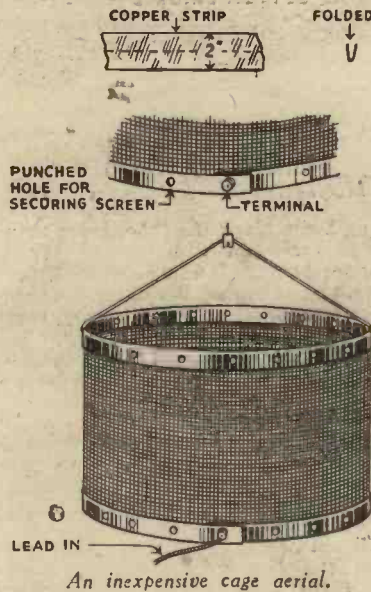

**A Cheap Cage Aerial**

AN efficient cage aerial can be made from the following materials: two pieces of ribbon copper 4ft. by 2ins. by 1/16in.; one piece of copper fly screen 4ft. by 9ins.; short piece of wire, terminal and an insulated hook. The pieces of ribbon copper are bent along their middle and folded over as shown. These folded strips are then bent over the edge of the fly screen and hammered down. Next, form the whole into a hoop, allowing the ends to overlap, and drill a hole for a terminal to which the lead-in is attached. Punch a number of holes in the doubled copper ribbon for securing the screen, and then drill two

holes in the top rim to take a piece of wire for hanging purposes.—Nitwitt (Croydon).

A volume control made from a spaghetti resistance.

**Low-loss Coil-formers**

QUITE a good substitute for low-loss ribbed formers, such as used for short-wave coils, may be made as follows. All that is required is a length of cardboard tube, and a few pieces of insulating sleeving.

As will be gathered from the diagram, about six or eight lengths of sleeving are cut to the same length as the tube, and

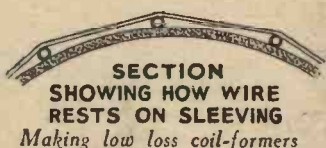
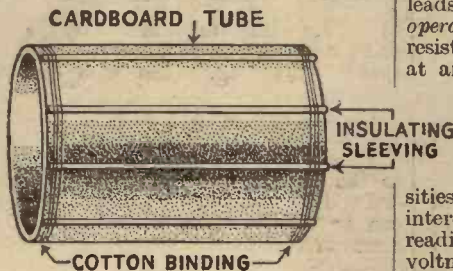

laid lengthwise along the tube, being then bound at each end with cotton. When the former is wound with bare wire, say 18 s.w.g. tinned copper, it will be seen that the wire rests upon the sleeving only, thus making quite a good low-loss former, with a low self capacity.—J. G. STOTT (Wednesbury).

**A Useful Adaptor**

THE parts required for making this handy adaptor are two valve holders and four valve pins with nuts. The valve holders are placed back to back and bolted together with the valve-pins inserted in the four sockets of the lower one. The nuts between the two valve-holders prevent the pins being pushed out of position. The filament and grid terminals are wired across as shown at A, and a piece of twin-flex is taken from the plate terminals to a milli-ammeter. Care must be taken that the pin in the plate socket does not touch the upper one, otherwise the meter will be shorted. I have found this a very useful

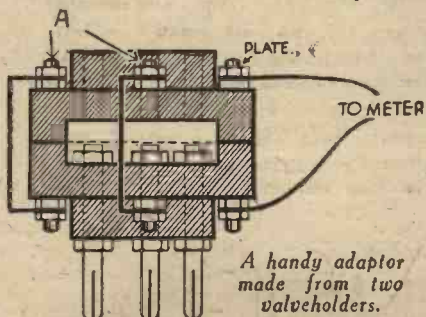

A handy adaptor made from two valveholders.

device for testing anode circuits, as it saves the bother of breaking connections, and once in position various other adjustments can be made.—W. H. FLEMING (Westcliff-on-Sea).

**Measuring A.C. Voltage**

THE measurement of the voltage of the raw A.C. current used for filament heater supply of all-mains valves presents a problem when an A.C. voltmeter is not available. The following simple method has been devised for this purpose. The

sketches illustrate the method used. Two 4-volt lamps of similar rating are mounted in lamp-holders on a small baseboard. One of these lamps is connected by means of flexible wires to the heater terminals of the set. The other lamp is connected through a variable resistance to a small battery of, say, 9 volts—a grid bias battery does very well—whilst a voltmeter is joined across the leads going to the lamp. The *modus operandi* consists in adjusting the variable resistance so that the two lamps are burning at an equal intensity. When this is the case, the voltage read on the voltmeter is the same as that of the A.C. supply. The two lamps can be partly screened in order to secure easier matching of the light intensities. As a final check, the lamps can be interchanged in their holders, a second reading taken, and the average of the two voltmeter readings noted. A change-over switch could, of course, perform the same operation in a quicker and neater manner.—R. J. MUNRO (Monkseaton).

**A Handy Bulb-holder Attachment**

THE sketch herewith shows a useful investigating lamp for a wireless set. The clips B and C are clipped straight on to

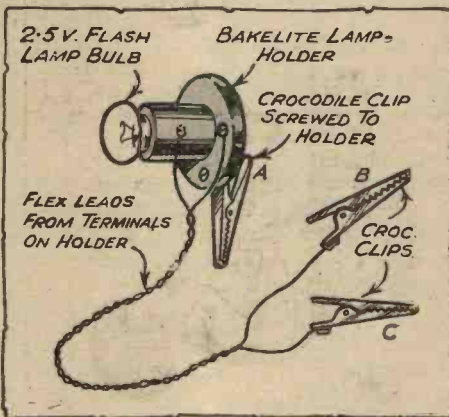

A simple inspection lamp.

the L.T. terminal stems (inside the set), to supply current to the bulb. The holder can be clipped on to any component or projecting point in the set without any fear of short-circuits, owing to the clip A being insulated by the bakelite holder.—J. Cross, Junr. (Reading).

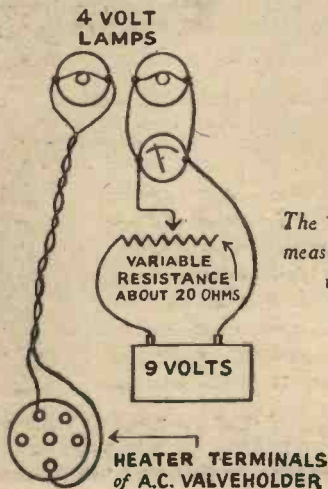

The method of measuring A.C. voltage.

**Metallising a Valve**

A SIMPLE but effective way to metallise a valve is to wrap it round with a piece of tinfoil obtained from a packet of cigarettes, as shown in the accompanying illustration. Around this wrapping bind a length of No. 36 copper wire, and



An easy way to metallize a valve.

earth it by soldering to one of the filament valve pins, or fastening to one of the filament terminals on the valve holder.—"Smiler" (North Ormesby).

**A Useful Earth-wire Clip**

SOME listeners may find difficulty in connecting their earth wires to the water pipes, as there is very little room between the wall and the pipe, which causes the wire to fray and bend upwards. A good method of overcoming this is to

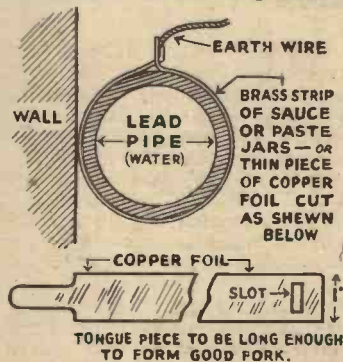

An easily-made earth-wire clip.

clean the lead pipe thoroughly and cut a small strip of copper foil as shown in sketch. Clean this strip thoroughly and slip it between the wall and pipe. It is easily fastened by the clip, which forms a good fork in which to slip the wire, where a spot of solder helps to eliminate any verdigris which may form.—G. Robertson (Fife).

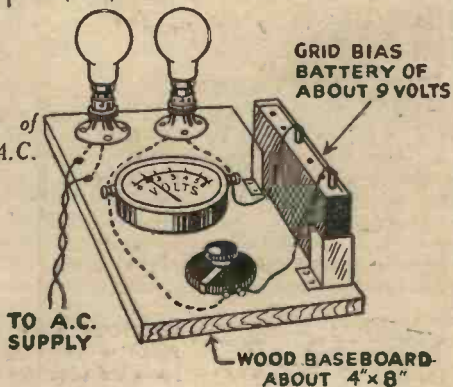

**TELSEN**

# DUAL-RANGE COILS



**TELSEN DUAL-RANGE AERIAL COIL** incorporates a variable selectivity device, making the coil suitable for widely varying reception conditions. This adjustment also acts as an excellent volume control, and is equally effective on long and short waves. The wave-band change is effected by means of a three-point switch and a reaction winding is included ... **7/6**



**TELSEN H.F. COIL** may be used for H.F. amplification with Screened-Grid Valve, either as an H.F. Transformer or, alternatively, as a tuned grid or tuned anode coil. It also makes a highly efficient Aerial Coil where the adjustable selectivity feature is not required **5/6**

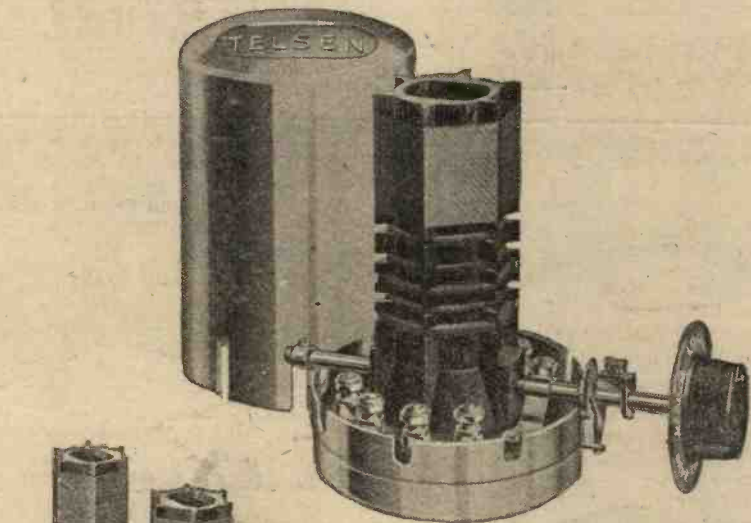

*Twin Matched Screened Coils*  
**17/-**

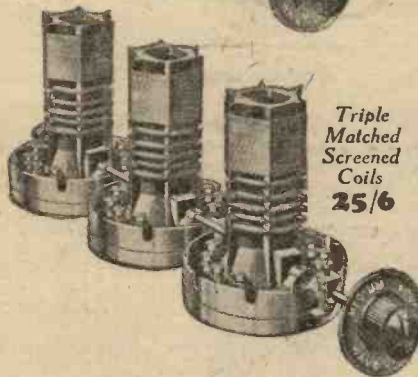
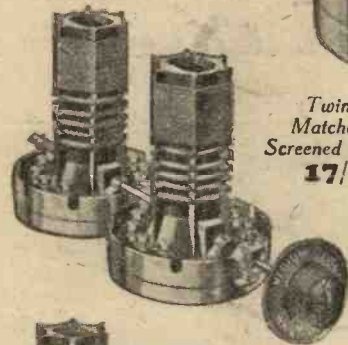

*Triple Matched Screened Coils*  
**25/6**

## TELSEN SCREENED COILS

The result of much research and experiment, these coils embody the ultimate efficiency attainable in a perfectly shielded inductance of moderate dimensions. Provided with separate coupling coils for medium and long waves, they are suitable for use as aerial coils or as anode coils following a screened-grid valve, giving selectivity comparable only with a well-designed band-pass filter. The coils are fitted with cam-operated rotary switches with definite contacts and click mechanism, and are supplied complete with aluminium screening cans, bakelite knob, and handsome "Wave Change" escutcheon plate, finished in oxidised silver **8/6**

*Full instructions are supplied with every Telsen Screened Tuning Coil, showing you the alternative methods of mounting the coils, either singly, or in twin-matched or triple-matched form as required.*

# TELSEN

**RADIO COMPONENTS**

**TELSEN RADIO COMPONENTS ARE 100% BRITISH**

ANNOUNCEMENT OF THE TELSEN ELECTRIC CO., LTD., ASTON, BIRMINGHAM



MICHAEL FARADAY



JOHN C. FULLER



GEORGE FULLER



LEONARD FULLER

**I** *t has happened*

**A PLATE-LESS  
ACCUMULATOR**

**R** *evolution at a stroke*



**TWICE THE LIFE  
PER CHARGE**

**PUT** away your existing accumulator. To-day the curtain is rung up on a new power-source, giving nearly twice as many hours' current for its price and size. It is the Block plate-less accumulator. Dreamt of by the famous Faraday's collaborator, John C. Fuller, to whom Britain's battery industry owes so much, pursued by his son and grandsons, after years of test it is here at last. Its secret is the elimination of those weak, heavy, space-wasting "grids" in which the present-day accumulator's paste is held. Besides double performance, it retains its full 2 volts even when inactive — no waste! Long-lasting, even if you drop it! A revolution! See your *The* dealer at once about this power-source of a new day. Booklet gratis.

**B L O C K  
A C C U M U L A T O R**

2 VOLT AMP : 7" CHOICE OF  
80 HOURS • 7" BEAUTIFUL  
CAPACITY HIGH COLOURS **11/6**



# Receivers and their Records

We shall be glad to advise readers regarding purchase of complete sets.

THE Telsen Electric Co. have been known in the past principally for their components, and it is only recently that they have turned their attention to complete receivers. A glance at the range of receivers which they are producing shows that they ought to be as popular as their components, if the finish is anything to go by. The cabinet work is certainly worthy of mention, and is finished in either a modern "de-luxe" style, or a simple French polished cabinet. The lines of the complete receiver are quite modern, and the speaker grille is certainly unique in design. There are only three controls, although four knobs can be seen on the front. The central knob attached to the

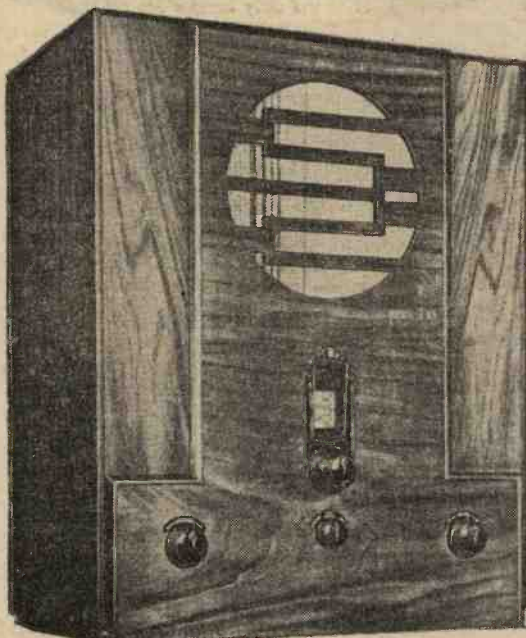

The Telsen "Golden Voice," Model No. 312.

escutcheon is the main tuning control (to which is fitted a concentric trimming control); the right-hand control varies the reaction; the left-hand control adjusts the selectivity, and the small knob in the centre is simply the wave-change switch. The mains on-off switch is conveniently placed at the rear of the receiver, a procedure to which no objection can be taken, as it enables the layout of the control panel to be kept on simple lines, and the switch is only required before and after listening-in.

#### The Circuit

The circuit arrangement is quite standard, and consists of the usual screen grid, detector and pentode valves (all of which are Mazda products), with a valve rectifier for the mains portion of the receiver. The detector valve is the new Mazda AC2HL, which has the enormous amplification factor of 72. This, coupled to the

### Telsen "Golden Voice," Model 312

pentode (an A.C. pen.), results in enormous amplification, and certainly justifies the use of the moving-coil loud-speaker which is fitted. The aerial is coupled to one of the screened coils through a special Telsen aerial series condenser which is provided with a shorting device which is automatically brought into action when in the maximum position. This enables it to be cut out of circuit when listening on the long waves.

H.F. transformer coupling is employed between the S.G. and Detector stages, and this also is a screened coil which is matched to the aerial coil, so permitting of accurate ganging. The tuning of these two circuits is carried out by means of the dial which has already been described in our pages, and employs the "shadow" trimming device on the scale which is calibrated in wavelengths. Tuning, therefore, could not be simpler. To couple the output valve a parallel fed L.F. transformer is employed, and a good step-up is provided here. The choice of the constants ensures good-quality reproduction. The arrangement of the various components of the circuit is very neat, and the metal chassis is employed to good purpose in efficiently screening and providing a neat appearance to the completed receiver. An interesting point here is the provision of mains fuses on the rear portion of the chassis. This part of the receiver also accommodates the on-off switch, sockets for an extra speaker, sockets for pick-up, a neat safety mains plug, and special hum-removing device for use where the mains are particularly noisy, together with a mains aerial socket.

#### Actual Results

The chassis is finished in a fine chromium plating and gives the receiver a really high-quality appearance. For the first test an outdoor aerial was employed, and the receiver was operated by a novice. No instructions at all were needed, as the listener turned up the programmes in the daily paper and saw that the London Regional programme was transmitted on a wavelength of roughly 356 metres. The central tuning knob was turned to this reading and naturally the programme came through fairly strongly. It seemed natural to this particular person to turn the concentric knob on this tuner, and this resulted in an increase of strength as it was rotated, but a decrease was noticeable as it was turned further. Consequently it was turned

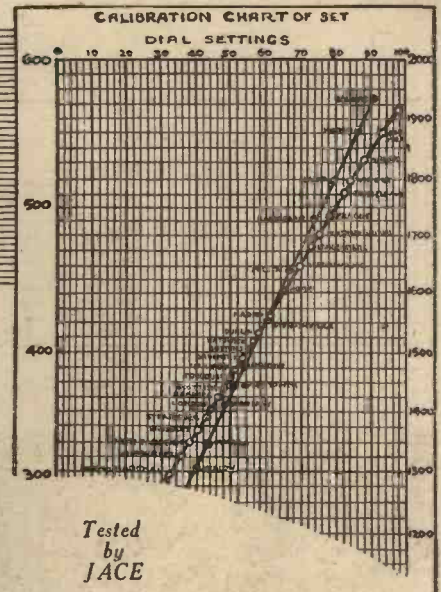

back to the maximum position. The left-hand knob was then adjusted and resulted in a further increase. Within three minutes, therefore, he was perfectly *au fait* with the method of operation, and immediately tried for other stations. The Midland Regional was suggested, and the tuning control only was adjusted to bring this station in at really fine strength, although in the heart of London in a badly-shielded position. A run round the dial produced over 20 stations without the slightest difficulty, and very little use was made of the reaction or selectivity controls. The quality on the powerful stations such as the B.B.C. stations, and the higher powered continentals was of a very high order indeed, and certainly merits the name which has been applied by the Telsen Company to these receivers, namely, "The Golden Voice." There were no undue resonances; no artificial bass or bass boom; no top note cut-off; no squeakiness; in fact, none of the troubles which one usually associates with a moderately-priced table model receiver. When the mains aerial was employed the actual range is, of course, reduced; but there are still plenty of stations to choose from. Over twenty stations were received at comfortable strength, although in the silent periods between programme items the hum was rather pronounced. Adjustment of the hum remover certainly reduced the strength of this interference, and although it did not completely remove it, it was so faint that it was not noticeable through speech or music.

At the price asked for this receiver, namely, 15 guineas in the de-luxe finish, this is certainly one of the best receivers which have been through our test room.

#### SPECIFICATION.

RECEIVER: "Golden Voice" All-Mains Three, Table Model.

MAKERS: Telsen Electric Co., Ltd.

SPECIFICATION: Three valves, Screen Grid, Detector and Pentode, Valve Rectifier, H.F. and L.F. transformer coupling, the latter parallel-fed. Moving-coil Loud Speaker with energised field winding. S.G. and Detector valves metallised. Ganged tuning with illuminated tuning scale, calibrated direct in wavelengths. Indicating control for the tuning trimmer. Three controls only.

PRICE: 15 guineas in de-luxe walnut cabinet; 12 guineas in plain cabinet.

# 70 Stations to choose from—

Grenoble (PTT)	Rabat	Brno	Bratislava	Lahf
Wlno	Dublin	Brussels No. 2	Helisberg	Radio Paris
Budapest	Katowice	Milan	Turin	Kouigs
Bundsvall	Radio Salsce	Poste Parisien	Lille	Wust'rhen
Riga	Midland Reg.	Goteborg	London	Darenty
Vienna	Bocharrest	Genoa	National	National
Brussels	Toulouse	Cardiff	Horby	Riffel Tower
Florence	Lwow	Bordeaux	Gleiwitz	Warsaw No. 1
Prague	Scottish Reg.	North National	Trieste	Mofana
North Regional	Alkiers	Tallinn	Belfast	Moscow
Langenberg	Stuttgart	Hilversum	Nurnberg	Kalundborg
Landessender	London Reg.	Bournemouth	Cork	Popoff
Rome	Graz	Newcastle	Fecamp	Oslo
Stockholm	Barcelona	Plymouth	Kaunas	Kiev
Moscow	Strasbourg	Swansea	Huizen	Leningrad

When you build a SKYSCRAPER THE ONLY SET YOU CAN BUILD YOURSELF EMPLOYING METALLISED S.G. VALVE, HIGH-MU DETECTOR AND ECONOMY POWER PENTODE

Here's a list of stations! Actually logged by a constructor at the first time of trying out a newly-assembled Skyscraper! What a record! What endless nights of entertainment! And everybody who builds the Skyscraper gets results like this—hundreds of appreciative letters prove it!

Never before was there such a set within the reach of the home constructor. Never before such power from any battery set. Never before so many stations as the Skyscraper brings in. It is the only set on the market that you can build yourself employing Metallised Screened-Grid, High-Mu Detector and Economy Power Pentode Valves. No factory—however well equipped—can build a better receiver. No manufacturer, however large, can produce a receiver whose results will surpass those you will get from the Lissen Skyscraper you build yourself. It is the only battery kit set that can deliver such power—yet the H.T. current consumption is far less than that of the average 3-valve set.

**GREATEST CHART EVER PUBLISHED!  
GREATEST SET EVER BUILT!**

Lissen have made the building of the Skyscraper extremely simple for you. Elaborate care has been taken to ensure your success by giving in the Skyscraper Constructional Chart such detailed instructions and such profuse illustrations that everybody, with no technical knowledge or skill at all, can build it quickly and with complete certainty of success.

You buy the Lissen Skyscraper Kit, complete with valves, a Lissen Metallised S.G., a High-Mu Detector, and a Lissen Economy Power Pentode Valve, and the price is only 89s. 6d. Or you can buy the Lissen Walnut Console Skyscraper Cabinet and Loudspeaker combined as illustrated. It holds all batteries, and accumulator and loudspeaker as well. It makes everything self-contained. A special Pentode Matched Balanced-armature Loudspeaker of great power is supplied with the cabinet, and the price of the Skyscraper Kit, complete with valves and this cabinet and loudspeaker, is only £6 5s.



COMPLETE WITH CABINET AND LOUDSPEAKER **£65** or 11/6 deposit and 12 monthly payments of 10/6.

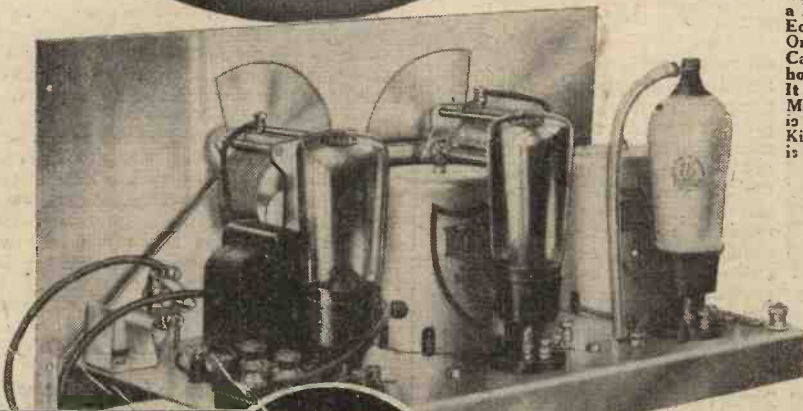

KIT COMPLETE WITH METALLISED S.G. HIGH MU DETECTOR & ECONOMY POWER PENTODE VALVES

**89/6**

Or 8/6 deposit and 12 monthly payments of 7/6.

**GREAT LISSEN CHART**

ASK YOUR DEALER OR **FREE** POST THIS COUPON



TO LISSEN LTD. Dept. P.W. 13, WORPLE ROAD, ISLEWORTH, MIDDLESEX.  
Please send me FREE copy of your 11- Skyscraper Chart.  
Name .....  
Address .....

**LISSEN SKYSCRAPER 3 KIT**

# "Practical Wireless"

# Christmas Supplement

## Contents

Christmas Fun with your Radio	ii
Wireless in Every Room	ib
Simple Home Broadcasting	b
A Seasonable Cartoon	vii
The Solo Knob Three	viii
If the Music Stops	xii
The Pick-up and the Party	xiii

To celebrate our first  
Christmas Number



# CHRISTMAS FUN



the tree. A microphone or speaker should be wired to the wireless set as described elsewhere in this issue, and father takes his place by the mike. The presents for the various kiddies must be wrapped in different coloured wrappings or in different ways so as to be easily distinguishable, and father must be provided with a list of these wrappings and the kiddies for whom they are intended. When the time for distribution arrives the youngsters gather round the tree, with, of course, strict admonitions not to touch anything—and father quietly disappears (into the other room, of course). Suddenly from the tree issues a deep voice bidding John or Mary to step forward. Upon the child mentioned approaching the tree the voice of the Tree request him or her to take the green parcel, or the blue box as the case may be. In this way the various presents may be distributed, and should there be a rather unruly child amongst the crowd a suitable "telling off" might be given with the present.



Without 'phones or speaker

### Receiving without Phones or Speaker.

Where the party consists of older people, say between the ages of twenty and thirty, a little experimenting would be quite a change from "Kiss-in-the-ring" or other similar games. The illustration above shows two people receiving the broadcast programme (or record if there is no broadcasting available) without the aid of headphones or loud-speaker.

For instance, a novel competition may be arranged, by bringing the single lead into the centre of the room, and baring the end. Ordinary single bell-wire is most suitable for this idea as it is fairly thick and stiff and is well insulated for the benefit of those who are inclined to be afraid of electricity. Switch on the receiver (with the loud-speaker wired in series with the

**W**ITH the festive season at hand there are a number of different ways in which the wireless set may be called into use to add to the enjoyment of the merry crowd which is bound to assemble on at least one day through the season. Elsewhere in this issue you will find how to use the loud-speaker as a dance band, or at least, how to produce your own dance music through the medium of the gramophone record, so we will not discuss this type of entertainment in this article, but will rather deal with what might be called "stunts," or rather unorthodox ways of using a wireless set.

### The Christmas Tree Speaks.

The first idea is related primarily to Christmas Eve, and is a novel version of Father Christmas. The children will have to have a Christmas tree, and it is natural that they should receive a present from the tree—a task which is usually performed by the head of the family—or rather, father. Instead of this manner of present distribution you will find this idea is much more modern, and the children will like it much more. Stand the tree in the corner, and behind it conceal a small loud-speaker. If desired the pot in which the tree stands could be made to accommodate the speaker. Leads from this are taken to another room, preferably one in which it is possible to see the tree, without being seen by the youngsters round

For this arrangement, two ordinary wires must be led from the loud-speaker terminals of the receiver, and the ends bared for a few inches. Now each person takes a bare end and holds hands with the free hand. Nothing will happen. If now a sheet of dry brown paper is placed between their two heads, and they incline their heads until the paper is sandwiched between their ears, the music or speech will be heard quite clearly. Remember, the paper must be perfectly dry and fairly stout. Different materials may be tried, and perhaps three or more may try out the idea.

### A "Wireless" Game.

When dealing with the Output Filter Circuit in our pages, we have repeatedly stated that only one lead is necessary for the loud-speaker; any earth connection completing the circuit. This fact permits a number of interesting things to be done with the one wire from the



The Christmas tree speaks—

# WITH YOUR RADIO

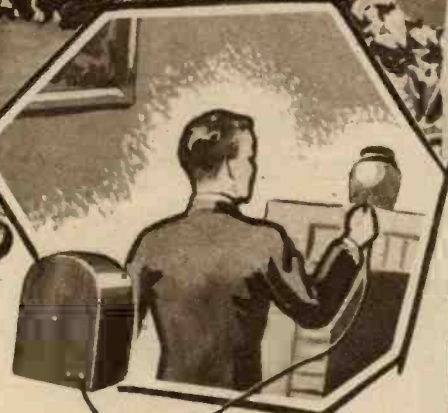

Completing the Circuit—  
a new game



The human aerial



—and the listener picks!

extension lead, of course) and then ask the members of the party to take the lead in turn and see who can find the music. By arranging this competition in a room where there are no good earth connections, and then concealing (before the party, of course) various earthed leads and joining them to different ornaments, chair backs, etc., a time limit could be imposed for each person, and much fun may be obtained by watching the endeavours of the "clever ones" to find a metal body. Remember, for this, that tin-foil, such as is found round chocolates, etc., will make a good connection, so fix pieces of this at different points and do not connect them all up. Of course it is understood that when the extension lead touches a point which is "earthed" the music will break through from the loud speaker.

### Europe Calling.

The same idea may be adapted to a table game. This may be called "Europe calling," or some similar title. If this one is used, obtain a large scale map of Europe (or draw one if you are gifted that way), and at the principal towns attach an ordinary paper fastener. (This should be of the type having two prongs about half-an-inch long and a head about 1/8 of an inch in diameter). At the back of the map attach another larger paper fastener, near one corner, and from the head of this (which is on the opposite side to the remainder) run thin leads to all of the other clips. The result of this is that on the right side of the map each town selected becomes represented by a large brass disc. The more towns you can employ the better the game. From the single large fastener run a lead to the loud-speaker, and from the earth lead run another wire to a metal plate or similar device under the table. (We assume, of course, that a filter is in use). From the metal plate a number of bare wires are then run, and these must

be long enough to reach to the centre of the table, via chairs placed round it. The members taking part in the game sit round the table, and each one is given the name of a town and one of the bare wires. When all are ready the set is switched on, and the M.C. calls out "London" or some other town. Immediately, the person who has been given this name has to put his bare wire on the brass stud representing his town and keep it there. The M.C. next calls another town, and he to whom it has been assigned places his wire on the town so named, which completes the circuit. By setting a time limit this may be given quite an interest for the younger members who are still at school.

### Musical Chairs.

If dance music is available, either from the broadcasting station or gramophone records, various devices to produce a sudden severing of the speaker lead may be thought of. As an example, the chairs may be set out in a row at one side of the room, and the participants stood at the opposite side of the room. Arrange a number of simple switches in a line—ordinary wire twisted together being good enough for the purpose. Have one or two of these wired up, the remainder being simply dummies. When the music is coming through, the participants commence untwisting the wires or pulling out the switches as the case may be, and as soon as one of those which is in circuit is opened, the music ceases, whereupon everyone dashes for the chairs. There is, naturally, one more member than the number of chairs, and one is unlucky. He, or she, falls out, and the circuit is remade, with an alteration in the switch or switches which are in circuit, and so the game continues until there is one left. That one is declared the winner.

### Wireless Charades

Arrange the microphone in one room, and the loud-speaker in another room. The party is divided into two groups, one remaining in the room with the loud-speaker, and the other going into the room with the mike. Before switching on, the microphone party decide on some song title. This should be of such a nature that it is capable of being translated, for the most part, into sounds. When decided upon, the circuit is completed. Then after a short interval to enable them to get ready the microphone party make the sound of rain falling. The party with the speaker have to guess the song title. When the title is discovered, the parties change round.

# WIRELESS IN EVERY ROOM

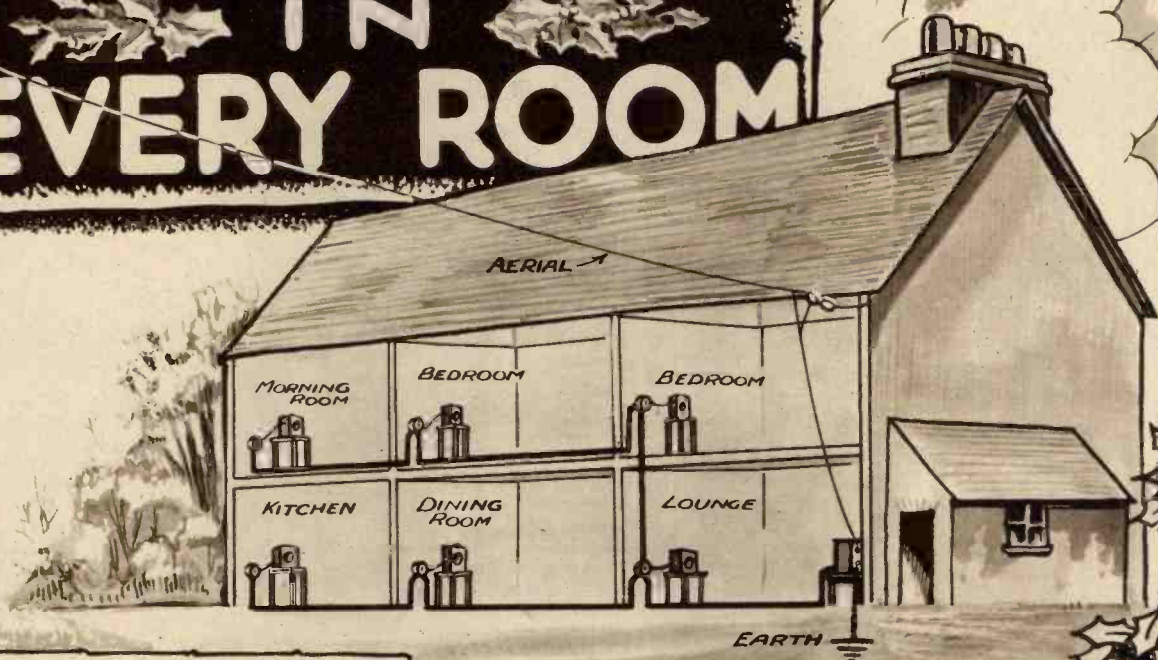

Fig. 1. Cut-away view of a house showing the various loud-speaker positions.

Fig. 3. Series and parallel wiring to a wall switch.

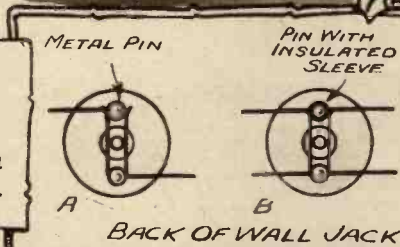

Fig. 2. Series and parallel wiring of loud speakers in diagrammatic form.

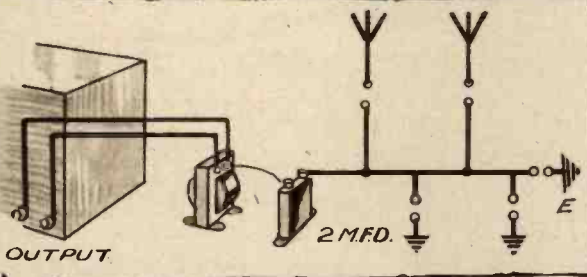
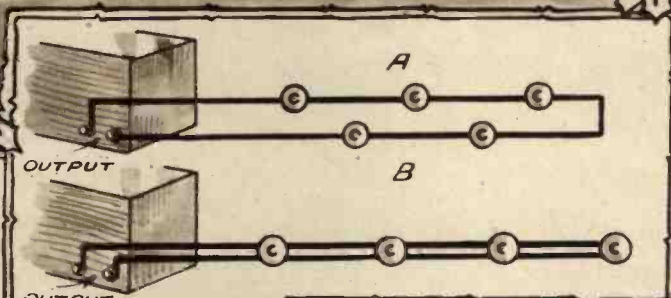

Fig. 5. The choke output filter circuit.

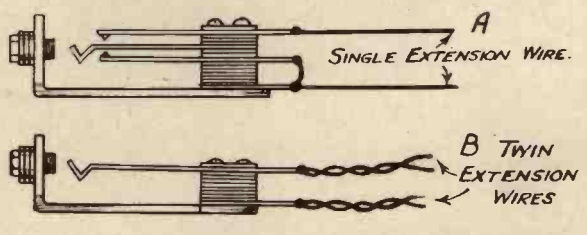

Fig. 4. Ordinary jacks wired for Series (A) or parallel (B) connection.



# Simple Home BROADCASTING

## BROADCASTING

RUN YOUR OWN BROADCASTING STUDIO THIS CHRISTMAS!

A GREAT deal of entertainment may be obtained from your wireless set with the simplest of apparatus that can be picked up second-hand for a few shillings. All that is required for the experiments to be described are a microphone, costing anything from five shillings upwards, and a telephone or microphone transformer that can be obtained from any dealer in second-hand electrical apparatus for about the same amount.

A glance at the accompanying illustration will show how simple the connections are. It is advisable to have the transformer and battery close to the microphone, and the extension leads can then be of any length from the secondary of the transformer to the pick-up terminals on the wireless set. If you have no pick-up terminals on the set, connect one wire to the grid of the detector, or first L.F. valve, and the other to L.T. negative or earth. To operate the microphone 1½ or 3 volts will be necessary, so that a small 3-volt torch battery may be used instead of a 9-volt grid-bias battery. An on-and-off switch can be inserted in the microphone circuit, so that the microphone can be switched on and off quickly.

**Simple Experiments.**

Now for one or two experiments that can be carried out with this simple hook-up. First of all let me warn you that if the microphone is at all sensitive, and the amplifier is at all powerful, it will not be possible to operate the microphone anywhere near the set or loud-speaker, as low-frequency oscillations will be set up that will result in a deep howl.

If the microphone is very sensitive you will then find that you will be able to hear low conversation that is going on in the room; or if the microphone is placed in the hedge in the garden you will hear snatches of conversation of people as they pass by. A motor-car will sound like the end of the world! and you will be able to hear the foot-

**Novel Entertainment.**

Having done this, arrange for some friends to come and listen to your special surprise item. With the audience in one room and you in the other with the microphone connected up, an evening's entertainment can easily be arranged.

Don't tell your friends that they are not listening to an ordinary broadcast item. While your friend has been performing, you slip in the room where the others are listening and note what they are doing. One might be smoking a pipe, or another eating. Just before the item is drawing to a close excuse yourself and slip out of the room into the next, and make an announcement such as the following: "Before going on to the next item will "So-and-So" (your friend's name) "please put out his pipe?" (Or stop eating sweets, etc.)

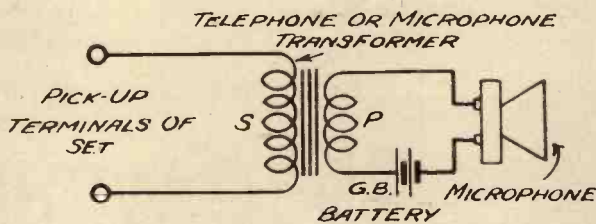

Connections for a microphone or microphone button

steps of pedestrians quite a long way off. However, this abnormal amplification of sounds becomes tiring in time, so then you can try the following experiments, using two valves—i.e. one stage of L.F. transformer coupled amplification. Suspend the microphone in a separate room at a convenient height to speak into, and then experiment with a friend and find out the right distance and the right tone in which to speak.



## Revolutionary development in Moving-Coil Speakers . . .

The new (patented) "Mansfield" Magnetic System lifts the whole subject of popular moving-coil speakers on to a higher plane. It makes possible a magnet 30% more efficient than the **best cobalt steel magnet of the same weight** and 10% more efficient than a **chrome steel magnet of three times the weight**. It enables a steel chassis to be used without magnetic loss. It eliminates the bug-bear of loss of magnetism.

There is nothing like it in the world. A magnet made on this principle comprises two steel alloys so arranged that the magnetic flux is concentrated in the small area where the work is done, instead of being distributed over the whole system. Thus, without extra

weight or cost, sensitivity is materially increased and the range of reproduction improved.

This secret, **now revealed**, accounts for the colossal demand for the new "Mansfield" permanent magnet moving-coil speakers (Senior and Junior) ever since we introduced them at Olympia. We have had to make repeated large extensions to our works and engage and train hundreds of additional workers—**and we can now meet demands for delivery**. Write for booklet then

**Ask your dealer for a demonstration: you will be AMAZED.**

"Mansfield" Senior (Improved P.M.4.) incorporates the new "Mansfield" system and gives astonishing results from any 2-, 3-, or multi-valve set. Complete with 3-ratio transformer 42/-

"Mansfield" Junior (P.M.5) also incorporates the above. Complete with 3-ratio transformer 27/6

The "Mansfield" Cabinet in well finished Oak. For models P.M.4 & 5 25/- extra.

Whiteley Electrical Radio Co., Ltd., Radio Works, Mansfield, Notts.

London Office: 109 Kingsway, London, W.C.2. Phone: Holborn 6714. Irish Free State Distributors: Kelly & Shiel, Ltd., 47 Fleet St., Dublin

## MATCHED TO WITHIN $\frac{1}{2}$ of 1%

### + HALF A MICRO-MICROFARAD

A rigid chassis that is all one piece — not merely a framework bolted together. A one-piece chassis so strong that there can never be the slightest distortion in use . . . this is the chassis of the J. B. NUGANG.

Trimmers to each stage inside the chassis are operated by external starwheels. Vanes wide spaced and of heavy gauge. Special rotor bearings ensure permanent accuracy and give remarkably free movement. Capacity .0005. Supplied semi-screened as illustrated or fully screened with lid.

Capacity without trimmers: Minimum 20 m.m.f. Maximum 520 m.m.f.  
Capacity of trimmers: 70 m.m.f.

Write for complete Catalogue.

#### NUGANG

	Semi-screened	Fully screened with lid
2-gang	14/-	2-gang 16/-
3-gang	21/-	3-gang 23/6
4-gang	28/-	4-gang 31/-



## PRECISION INSTRUMENTS

Advertisement of Jackson Bros. (London) Ltd., 72, St. Thomas' Street, London, S.E.1.

Telephone: Hop 1929.







# The Solo Knob

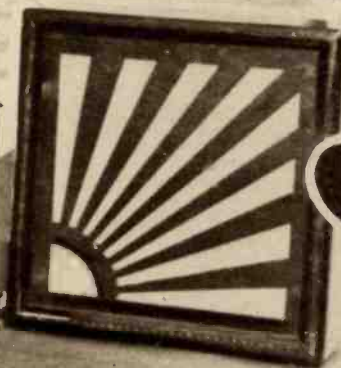

# 3

**A** THREE-VALVE receiver with only one knob on the panel, yet possessing all the usual controls—tuning control, reaction control, wave-change switch and on-off switch! On the face of it this appears to be rather a difficult, if not an impossible, problem. But it has been solved in the Solo-Knob Three. If you are without a radio set, there is ample time for you to make up this splendid little receiver which employs the time-honoured circuit in a novel way. The construction has been made possible by the ingenious Lissen component which forms the only panel mounting part of this receiver, and this incorporates two condensers, and the combined

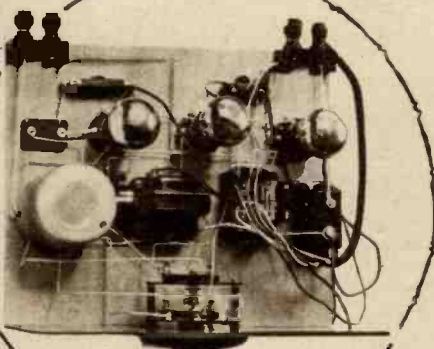

Top view  
of the Solo Knob

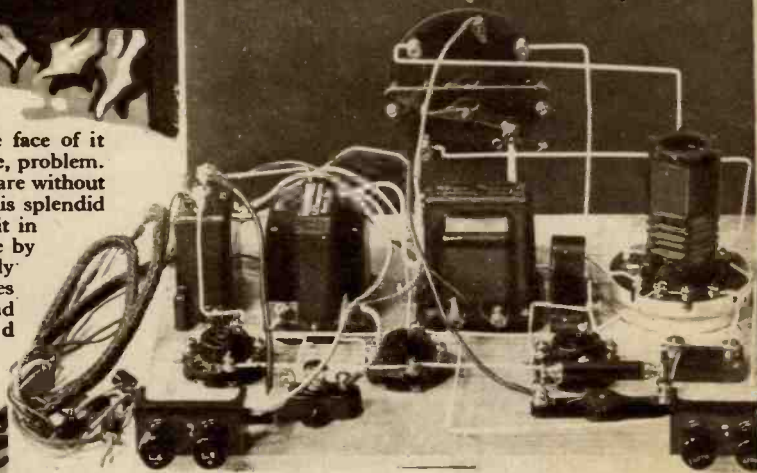

Rear view of the Solo Knob—with valves and screen removed to show wiring

switches which are needed. As will be seen from the illustrations, this forms a very neat and attractive panel mounting, and adds to the simplicity of layout and wiring.

#### The Circuit Explained.

The circuit, as will be seen from the circuit diagram, consists of the conventional Detector and two L.F. stages, transformers being used for the couplings. The coil is one of the modern shielded coils, and although only one coil is employed in this receiver it has been thought desirable to employ this form of coil in order to avoid direct pick-up in the locality of a powerful station. There are no other points of interest in this receiver, so we can pass on to the actual constructional details.

**A SPLENDID,  
CHEAP AND  
QUICKLY-MADE  
THREE-VALVER  
OF THE DET.  
& 2L.F. TYPE,  
WITH SINGLE  
KNOB  
CONTROL**

Rear view of the Solo Knob with valves and coil screen in place

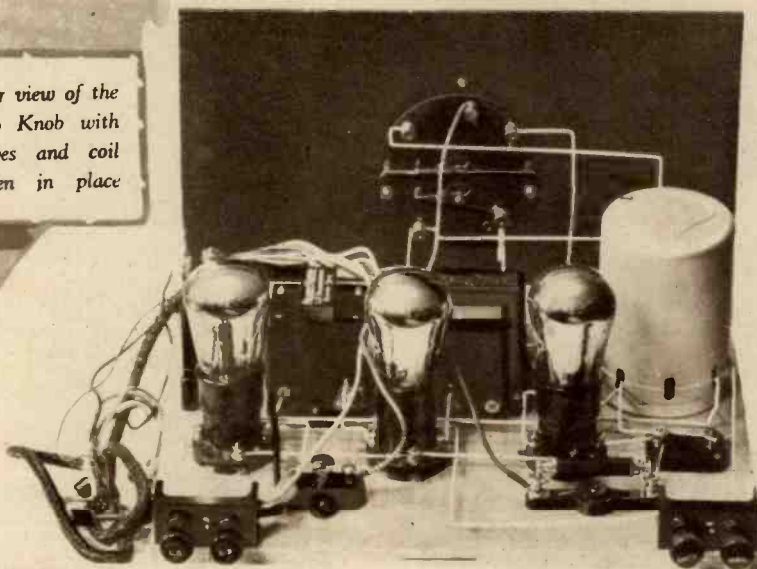

**LIST OF COMPONENTS**

- 1 Lissen Ganged Condenser Tuning Control Unit.
- 1 Telsen Matched Serviced Coil.
- 1 Ready Radio 3-1 Transformer.
- 1 Telsen Ace 5-1 Transformer.
- 1 T.C.C. .0002 Fixed Condenser, Type 8.
- 1 T.C.C. 2 mfd. Fixed Condenser, Type 50.
- 1 Graham Farish Horizontal Grid Leak Holder.
- 1 Graham Farish 2-megohm Grid Leak.
- 1 Bulgin Base-board Fuse Holder and Fuse.
- 1 Bulgin 10,000 ohms Spaghetti Resistance.
- 1 Graham Farish Snap H.F. Choke.
- 3 W.B. 4-pin Valveholders.
- 1 Ebonite Panel (Permeol), 12 in. by 7 in.
- 1 Coil Glazite Connecting Wire.
- 1 Cossor 210 Det. Valve.
- 1 Cossor 210 L.F. Valve.
- 1 Cossor 215P. Valve.
- 1 Belling Lee 5-way Battery Cord.
- 1 Ediswan 105 volt Super H.T. Battery.
- 1 Ediswan 9-volt Grid Battery.
- 1 Ediswan 2-volt 40 amp. Accumulator.
- 1 Ormond Loud-Speaker, Type 452.
- 1 Osborn Cabinet Type 178.
- Screws, Flcs., 3 Wander Plugs (G.B., G.B.1, and G.B.2).
- 1 Tin of Filt.
- 1 Wooden Baseboard, 12 in. by 10 in.

**Construction.**

The only point which calls for attention in the construction is the mounting of the combined condenser assembly. The makers' instructions should be followed when mounting this, but to make the matter perfectly clear the following notes will be found of interest.

The centre of the assembly is in the exact centre of the panel, so this should be marked first. The centre hole is not exactly critical, so that a series of small holes will be found the best way of drilling this. The holes should be practically touched, and then the piece knocked out. The fixing holes must be accurately drilled to ensure a firm fitting for the ebonite escutcheon. When the holes are drilled, take the condensers off and dismantle the assembly as described in the Lissen pamphlet, and assemble the whole on the panel. Note that the small screw must be removed from the upper knob to enable the two condensers to operate independently. Mount

the coil and other baseboard components, and wire up, using the wiring diagram as a guide. There are no difficulties to be encountered here, and this work will be found perfectly straightforward, provided the diagram is kept by your side whilst you are working. Where the glazite is joined to the coil terminals, take care not to bare too much wire or it will short-circuit on to the case.

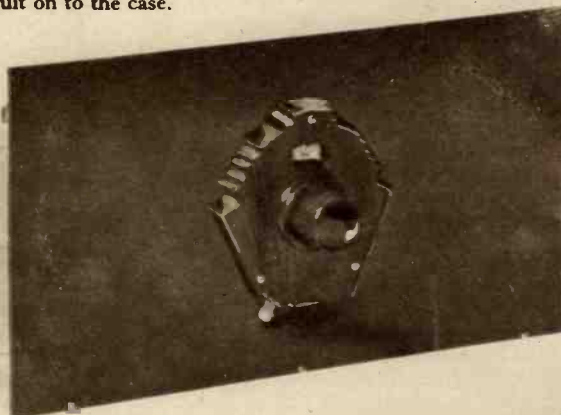

Three-quarter front view of the Solo Knob

**Operation.**

When completed, the receiver may be put into operation.

Plug a Cossor 210 Det. valve into the socket nearest the coil; a Cossor 215P. valve into the socket at the other end of the baseboard, and a Cossor 210 L.F. in the centre socket. H.T.+1 should be plugged into the 80-volt tapping, and the H.T.2 into the end tapping of the battery, namely 105 volts. The grid bias plugs should be inserted in the battery as follows: G.B. + into the positive end of the battery, G.B.1 into the 1.5 volt tapping, and the G.B.2 plug into the 7.5 volt tapping. The front knob on the tuning unit controls the station selection, and the rear portion of the knob controls the reaction condenser. The lever at the bottom controls the wave range and also brings the receiver into operation. The engravings on the ebonite escutcheon make this part of the scheme quite clear. In most localities this receiver will give a good selection of stations on the loud-speaker, and will provide an ideal home receiver, capable of being used by every member of the family.

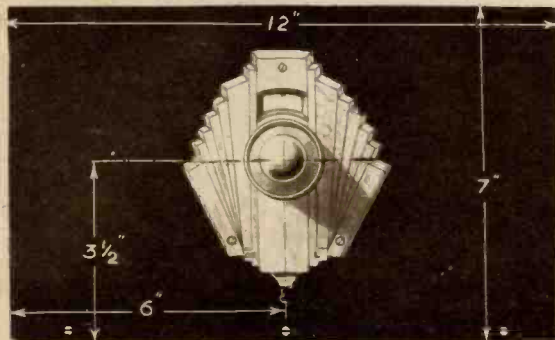

Front of Panel Diagram

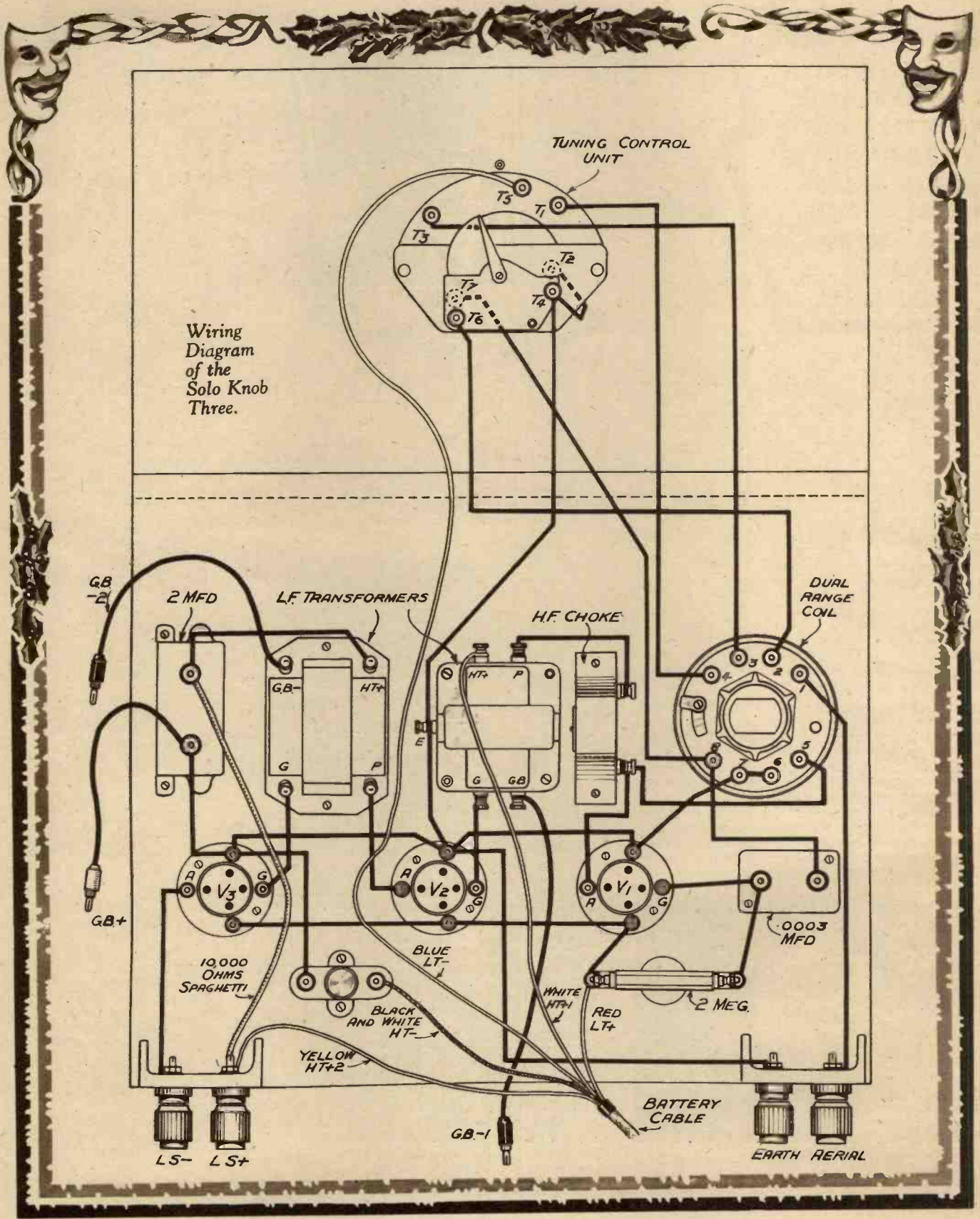

Wiring Diagram of the Solo Knob Three.

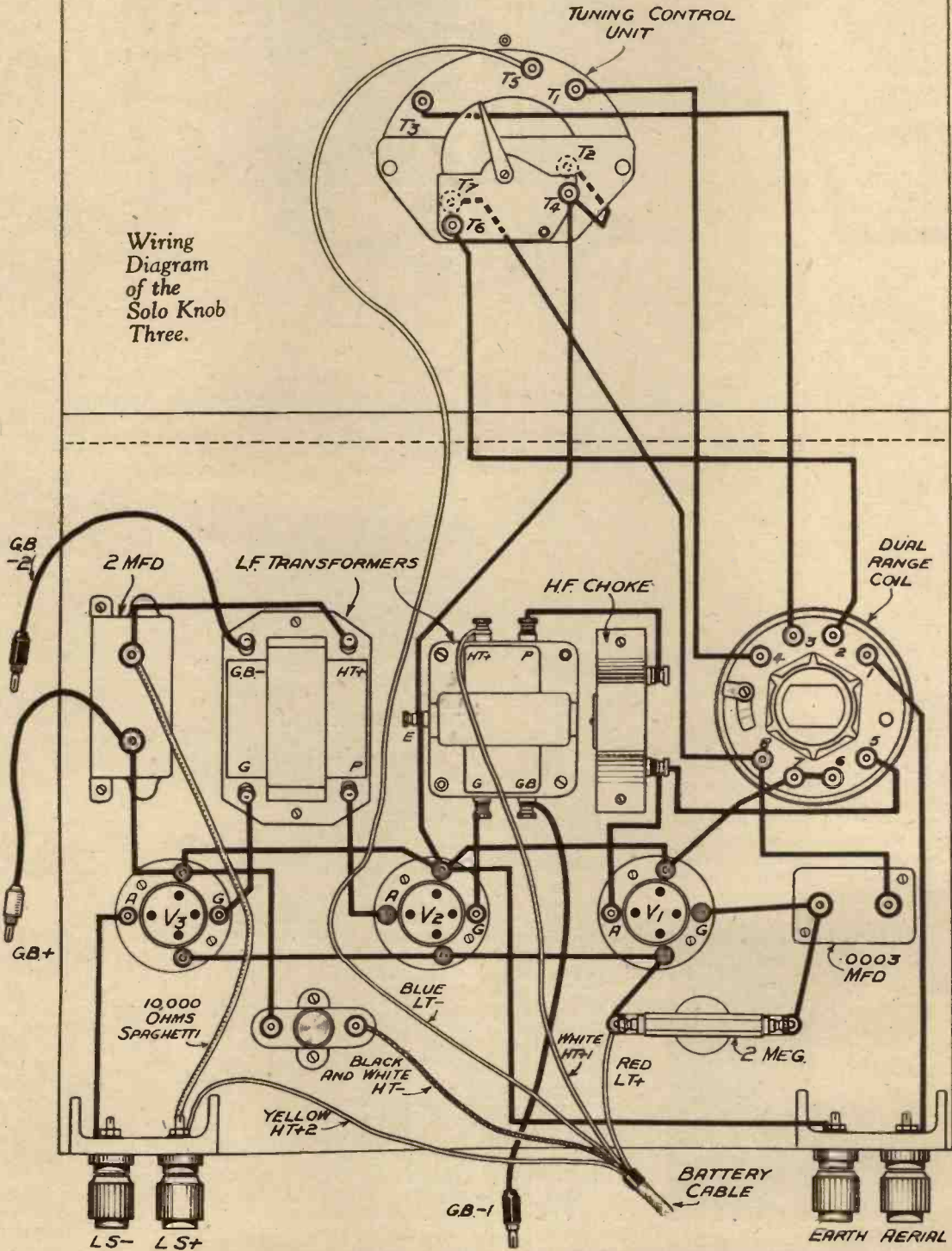

# Yours for Better Radio this Xmas

## Peto-Scott



### PILOT AUTHOR KIT SOLO-KNOB 3

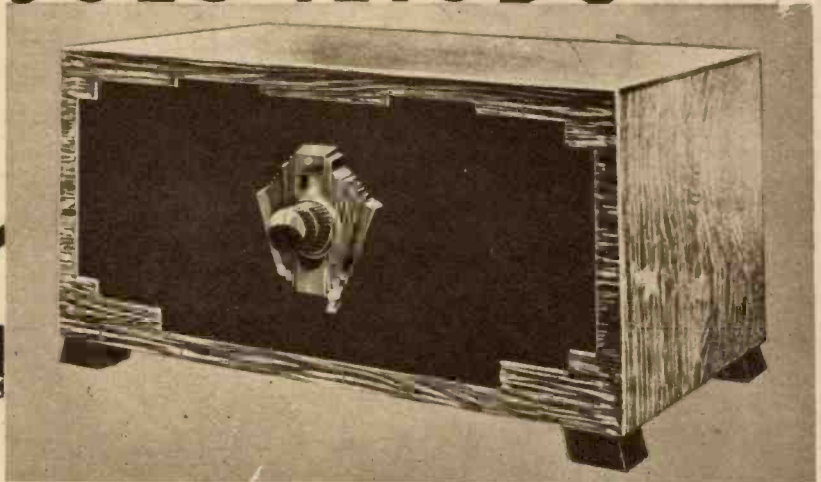

**GIVE YOUR SET  
THIS XMAS PRESENT**



**PETO-SCOTT WALNUT CONSOLE**  
Constructed in Walnut with contrasting inlaid Walnut Veneers.

Comes to you with vignette, ready to take any set. Transforms your Radio into a beautiful Console Instrument, presenting the professionally finished appearance of the most luxurious Radio Receiver money can buy.

Baffle Board Ready Drilled 3/6 extra.  
Carriage and Packing 2/6 extra England and Wales.

**62/-**

or 12 monthly payments of 5/8

**THESE ARE THE PARTS  
THE AUTHOR USED**

	s.	d.
RED TRIANGLE Ebonite Panel, 12" x 7" ready drilled	3	6
Laminated Baseboard, 12" x 10"	1	3
LISSEN Ganged Condenser Control Unit	14	6
TELSEN Matched Screen Coil	8	6
W.B. Valve Holders	1	6
GRAHAM-FARISH Snap H.F. Choke	2	0
READY RADIO 3-1 L.F. Transformer	8	6
TELSEN ACE 5-1 L.F. Transformer	5	6
T.C.G. .0002 Mfd. Fixed Condenser Type S	1	3
T.C.G. 2 Mfd. fixed Condenser Type No. 50	3	10
GRAHAM-FARISH Grid-Leak Holder	1	6
GRAHAM-FARISH 2 Meg. Ohmite Resistance	1	6
BULGIN 10,000 Ohms. Spaghetti Resistance	1	0
BULGIN F.5 Fuse and Holder	1	0
BELLING-LEE 5-way 30" Battery Cord	2	0
BELLING-LEE marked Terminals	10	
BELLING-LEE Terminal Blocks	1	4
Quantity of Insulated Connecting Wire, Fixing Screws and Flex with 2 Wander Plugs	1	6

**KIT "A" CASH OR C.O.D. £3 0 0**

**KIT "A"**

Author's Kit of specified parts including ready drilled panel, but less valves and cabinet.  
CASH or C.O.D. Carriage Paid.

**£3 - 0 - 0**

or 12 monthly payments of 5/6

**KIT "B"**

As Kit "A" but with Valves, less Cabinet, CASH or C.O.D.

Carriage Paid  
**£4-2-9**

or 12 monthly payments of 7/6.

3 Specified Valves £1-2-9 Cabinet 15/-

**KIT "C"**

As Kit "A" but with Valves and Table Cabinet as illustrated.

CASH or C.O.D. Carriage Paid  
**£4-17-9**

or 12 monthly payments of 9/-

**PILOT STRUCTAKIT**

Comprises: RED TRIANGLE Ready Drilled Ebonite Panel, 12" x 7"; RED TRIANGLE Drilled Terminal Strip; Non-Warping Laminated Ply Baseboard 12" x 10"; Insulated Connecting Wire, Fixing Screws and Flex.

**6/6**

**IMPORTANT**—Parts, Kits, Miscellaneous Components, Finished Receivers or Accessories for CASH, C.O.D. or H.P. on our own system of Easy Payments. Send us a list of your wants. We will quote you by return. C.O.D. orders value over 10/- sent carriage and post charges paid.

**PETO-SCOTT CO. LTD. 77, CITY RD. LONDON, E.C.1**

Tele.: Clerkenwell 9406-7 West End Showrooms: 62 High Holborn, London, W.C.1. Tele.: Holborn 3248

Dear Sirs, Please send me CASH C.O.D./H.P. for which I enclose £.....d. CASH/H.P. Deposit.

NAME .....

ADDRESS .....

PR. W. 10/12/32

# IF THE MUSIC STOPS!

Simple Emergencies which will keep the set in action

**T**HERE is always the possibility that the wireless set will go wrong at the critical moment—that is, when all the shops are shut, and your party is at its height. The following hints suggest some "stand-by" methods of overcoming the trouble, and it should be possible rapidly to effect a cure for the stoppage, even if the resultant signals are reduced in strength. If you are using 2-volt valves, the electric bell cell may be pressed into use to finish the programme out. It will not last long, of course, but it will give enough to enable you to hear how the Hero marries the Heroine.

Suppose that the H.T. battery suddenly starts to give up the ghost. Put it in the oven for a **SHORT** time. Don't leave it too long, or the wife will be after you to clean up the melted pitch. A little warmth will help it to give an increased output for a short while. In the event of the set suddenly going dead, remove the aerial and, if the set employs H.F. stages, put the lead-in on the grid end of the coil which is included in the Detector valve circuit. If it is on the H.F. side that the trouble originates, signals will

be obtainable by this change-over, but, of course, at a much reduced strength. If two L.F. stages are in use, the speaker may be joined in place of the primary of the first L.F. transformer. This cuts out the last stage. Either of these two methods may be adopted, and then the valves shuffled round, so that if a valve is the cause of the trouble it will be speedily found, and the first or last valve of the receiver cut out of circuit, with a valve in each of the remaining holders. Of course, where the incorrect valve is used

blown or otherwise broken, the H.T.—terminal may be joined to earth with a short length of wire. If your guy-rope should chance to break during a programme, remember that the aerial wire may be laid along the top of the garden fence and will give quite good results for the time being. A nail here and there will keep it in position until the rope or mast can be renewed. Ordinary thin wire may also be called into use as an indoor aerial, or a fixed condenser in series with the mains lead may be employed until the emergency period has passed.

Supposing that your receiver employs an R.C.C. stage, and you find that one of the resistances has broken down. A piece of stout paper, and a smearing of blacklead (obtained from the household cleaning box) such as is used for polishing the fire grates, will make quite a good temporary resistance. The value is varied, of course, by the amount of lead on the paper. Ordinary lead pencil may be used instead of the blacklead paste, but is not so good.

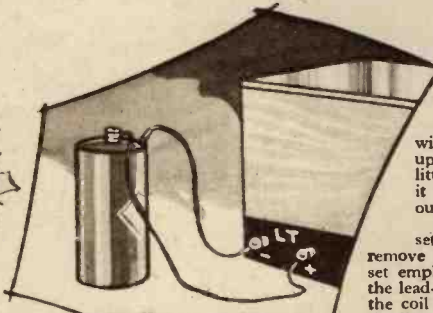

A 12-volt dry cell is a useful stand-by

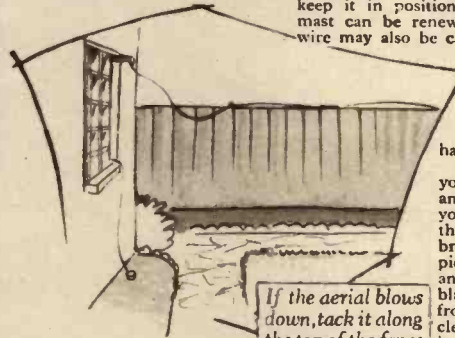

If the aerial blows down, tack it along the top of the fence

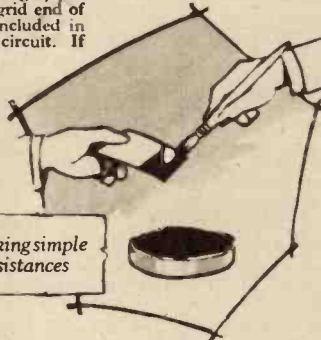

Making simple resistances

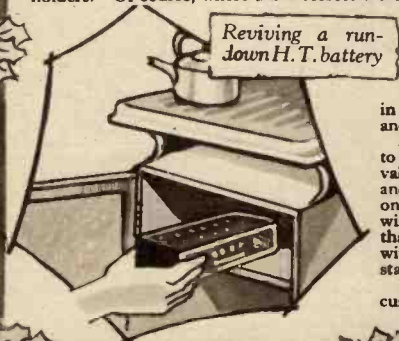

Reviving a run-down H.T. battery

in a certain stage it will be necessary to readjust the bias and probably the H.T.

Another simple method of cutting out one valve is to join together the grid sockets of two succeeding valves. Ordinary D.C.C. wire may be used for this, and the wire may be fixed either to the actual terminal on the valve holder, or from the components which are wired to that terminal. This method has the advantage that the Detector valve circuit may be transferred, without inserting a grid leak and condenser in an L.F. stage.

If you have a battery set, and it is fitted with the customary fuse in the H.T.—lead, and this should be



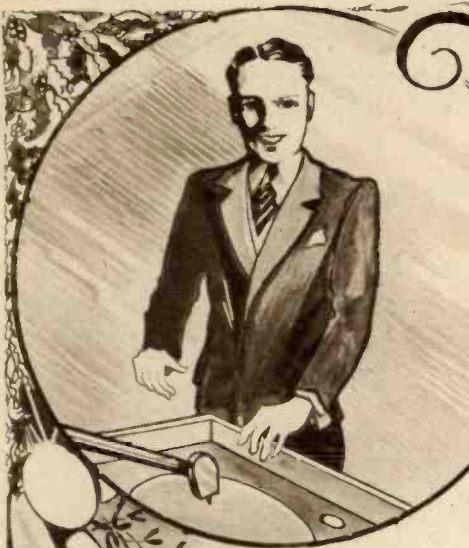

# The PICK-UP AND THE PARTY

By H. J. Barton Chapple,  
Wh.Sch., B.Sc.

pick-up together with full instructions for mounting. The difficulty, for the amateur, usually lies in the method of connecting the pick-up to the receiver.

Fig. 1 shows the layouts (but not the circuits) of a number of typical receivers and indicates at what points the pick-up connection should be introduced, together with alternatives.

**S**OME practical hints on the fitting, connection and operation of a gramophone pick-up may not come amiss at this time when many radio listeners are contemplating the purchase of this accessory, either as a normal extension to their existing equipment, or as a Christmas present for the family. For the party, when the band music via the radio is not available, the electrical pick-up can be pressed into service to provide the strains of melody to guide the witching feet.

To fit a pick-up all that is necessary is to remove the original sound box from the tone arm of the gramophone and substitute the pick-up. In many cases, however, it is found better to incorporate a special tone arm, this being supplied complete with the

Whatever the stage at which the pick-up connection is made, one rule universally applies. It is: **ONE LEAD FROM THE PICK-UP TO GRID BIAS NEGATIVE AND THE OTHER WIRE FROM THE PICK-UP TO THE GRID OF THE VALVE.** It is also desirable, but not always essential, that the "normal" connection to the grid of the valve should be broken when the pick-up is in use. In Fig. 2 A and B, diagrams are drawn to help make these clear. It shows the theoretical connections of a pick-up to a detector valve and to the first low frequency valve in a battery-operated receiver. In the case of A.C. mains sets where automatic grid bias is provided, the arrangement is slightly different, but we will discuss this later.

The very simplest method of making the connection and one which calls for no alteration of the wiring whatsoever, is by means of a piece of apparatus known as a "pick-up adaptor." This is a plug having four pins in the base corresponding to the four sockets of the detector valve and four sockets in the top to take the pins of the detector valve. Two terminals are provided at the side and to one of these,

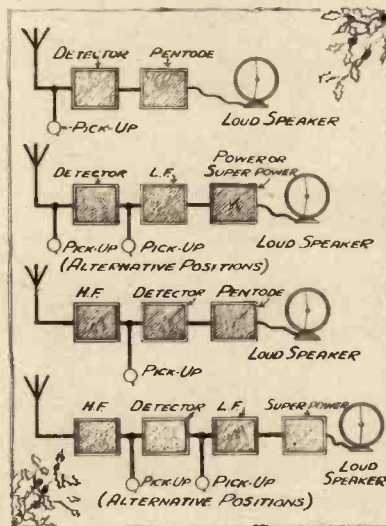

Fig. 1.—Diagrams showing various methods of connecting a pick-up

If a receiver employs two low frequency stages after the detector valve, both these stages should be used for the pick-up and the pick-up connection must be made to the grid circuit of the first low frequency valve. How this connection is made we shall see later.

Many modern receivers, especially those employing a pentode output valve, have but one low frequency stage. In such cases, the pick-up must be connected to the grid of the detector valve and provision made for applying negative grid bias to the detector valve so that it may operate satisfactorily as a low frequency amplifying stage while records are being played.

In receivers employing one or more high frequency valves, these valves will not be used.

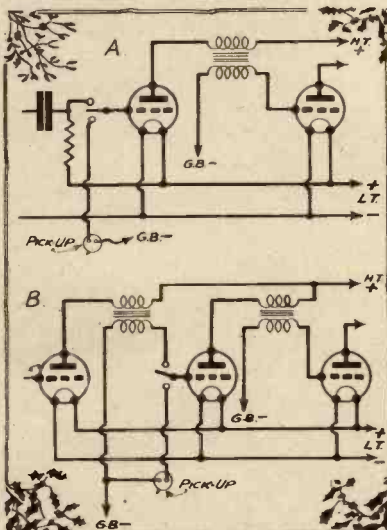

Fig. 2.—Two methods of fitting a pick-up switch



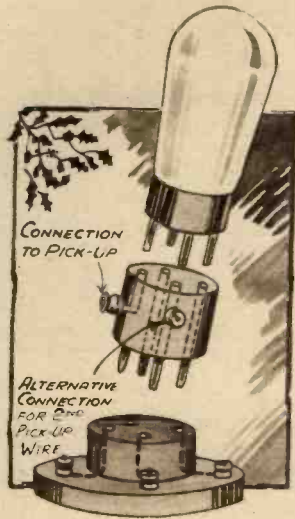

Fig. 3.—A simple plug-in pick-up adaptor

usually marked "pick-up" or "grid," one wire from the pick-up is connected. The other wire from the pick-up is joined either direct to the correct tapping on the grid bias battery, or in the case of certain detector valves which are operated at a low anode voltage and therefore require no grid bias when used as an amplifier, the second pick-up wire is connected to the second terminal of the adaptor.

To fit the adaptor all that is necessary is to pull out the detector valve, insert the adaptor with the pick-up connections made in the detector valve holder, and replace the detector valve in the top of the adaptor. Fig. 3 shows the adaptor with the appropriate connections for this purpose.

It is far better to have the pick-up leads connected permanently to a pair of terminals at the back of the receiver and to instal a switch somewhere in the set to make the changeover at any time without the inconvenience of making additional connections or groping inside the set. To those readers who contemplate the use of a pick-up for their Christmas festivities, it is preferable for them to make the slight alterations at the present time so that no delay will occur during the festive season when the pick-up may be required at very short notice. As a temporary measure one lead from the pick-up can be joined direct to the grid of the valve (detector or low frequency, whichever is being chosen as the first

stage of the gramo-amplifier) as indicated in Fig. 4.

**Pick-Up Terminals.**

If possible, a pair of terminals should be fitted to take the pick-up wires. One of the many neat terminal mounts designed to accommodate two terminals may be fitted to the baseboard at the back of the receiver.

**Pick-Up Switch.**

A good many listeners make a very neat job by fitting a small and compact changeover switch of the push-pull type on the terminal strip of their sets. Sometimes it is possible to cut a slot at the back of the receiver and insert a small plate of ebonite to carry both terminals and switch. Failing this, a switch may be mounted on a small sub-panel inside the set carried by brackets from the baseboard or from the side of the cabinet.

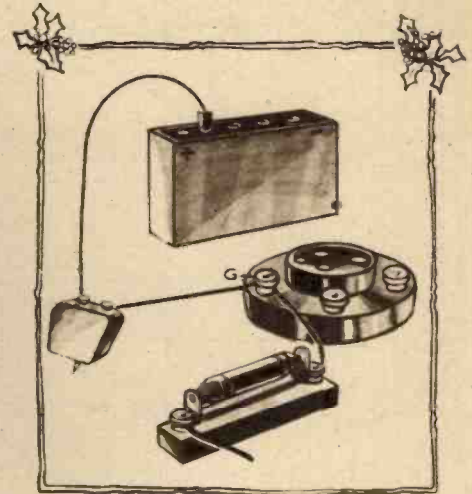

Fig. 4.—How bias is applied through the pick-up

This arrangement holds good for battery operated sets and also for A.C. mains receivers where battery bias is employed. If, however, it is desired to use automatic bias for the detector valve, the connections are rather different and are as indicated in Fig. 6.

The grid wires should pass to the switch in such a way that there is no risk of coupling between the grid wire and other parts of the circuit. This is of special importance in A.C. mains sets in which it is essential that the grid wires are well spaced from the low tension leads carrying the heating current, otherwise there is a considerable risk of mains hum being induced in the grid circuit and thus upsetting reproduction.

**Fitting a Volume Control.**

The method of control is to connect a potentiometer across the pick-up, the lead to the grid of the valve being taken from the slider as indicated in Fig. 7. The correct resistance for the potentiometer will be between 50,000 and 500,000 ohms. Fig. 8 is a scratch filter circuit.

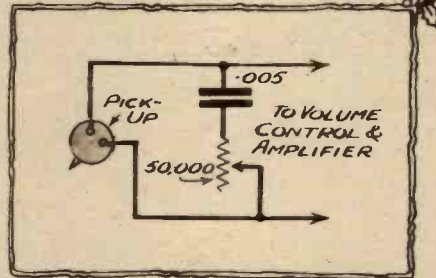

Fig. 8.—Circuit for scratch filter

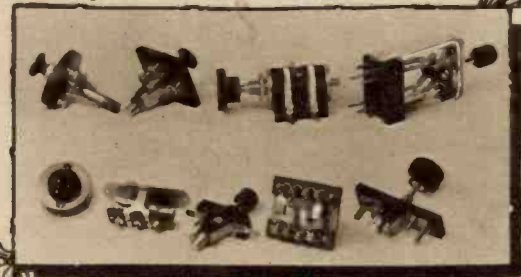

Fig. 9.—Representative group of suitable switches for pick-ups

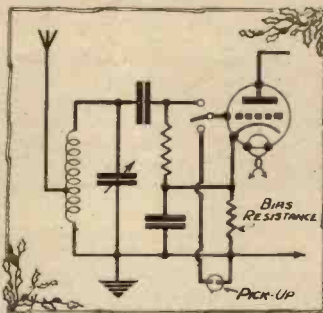

Fig. 6.—Biasing an indirectly-heated valve

**Types of Switch.**

Any form of single pole changeover switch (see group in photograph Fig. 9) is satisfactory, but the best is undoubtedly that of the "snap" variety. If the switch is to be mounted on a metal panel, see that the switch is of the "bushed" type.

As an alternative to a switch a plug and jack may be employed. This should be of the "two circuit" type.

**Switch Connections.**

Fig. 5 shows the theoretical connections for a switch to insert a pick-up in the detector grid circuit.

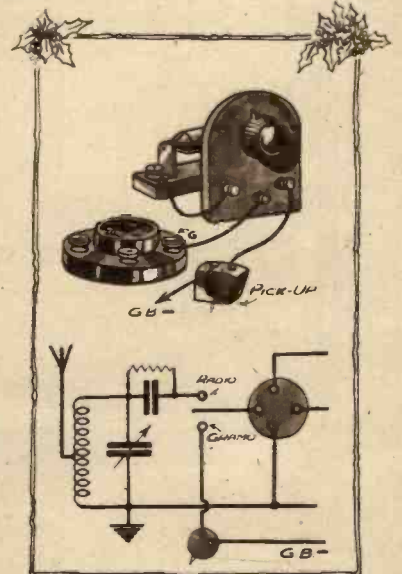

Fig. 5.—Connection of the switch and pick-up

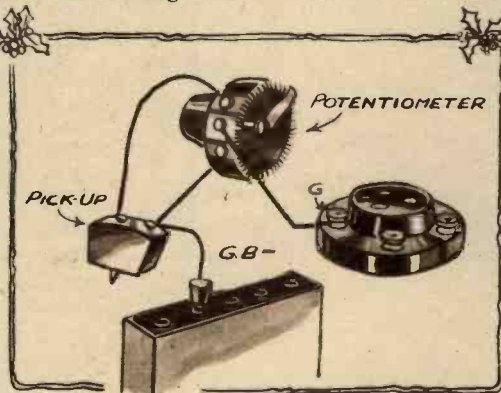

Fig. 7.—Connecting a volume control



# SPECIALLY RECOMMENDED FOR THE "SOLO-KNOB"



### PRICES

- 105 volt Super Capacity H.T. Battery **21/9**
- 9 volt Grid Bias Battery **1/-**
- Type E.L.S.5 "Extra-Life" L.T. Accumulator **11/-**

### Guarantee

The Edison Swan Electric Co. Ltd guarantees that Edison Swan Batteries are of full voltage and capacity. Should any Edison Battery fail to give satisfactory service, we undertake to deal with customers' complaint within 24 hours of receipt of the defective battery.

The designers of the "Solo-Knob" have recommended Edison Swan Batteries and Accumulators for these reasons: the new process by which Edison Swan H.T. Batteries are manufactured has raised such a high standard of long life and efficiency that it is possible to issue a positive Guarantee with every battery; while the new "balanced capacity" principle in the design of Edison Swan "Extra-Life" accumulators allows these cells to be charged more quickly and to give a longer life per charge. You can be sure then, that when you equip your "Solo-Knob" with Edison Swan, you are using the best and the most economical batteries.

From all good radio dealers.

# EDISWAN

ACCUMULATORS **EXTRA-LIFE** H.T. BATTERIES and



# NEW "SQUARE PEAK" SUPERHET—

You may use it in any room  
without external aerial

SELECTIVITY... day by day the need grows  
greater. Secure it in a Varley Superhet.

Knife-edge selectivity, fine quality and single  
knob control. Station after station **clearly**  
heard on the built-in moving-coil speakers.  
Radio in every room! For the local station  
just connect the set to any lighting socket  
and plug in the handy little "portable" aerial  
supplied.

Write for **FREE** art booklet and address of  
nearest dealer. He will gladly demonstrate  
Varley.

*For use with external aerial or with handy portable aerial  
supplied. Five valves and rectifier. VARIABLE MU H.F.  
AND INTERMEDIATE FREQUENCY STAGES. Six  
tuned circuits with SINGLE CONTROL TUNING (remain-  
ing knobs on front are Volume and Mains Switch). BAND-PASS  
INTERMEDIATE FREQUENCY COUPLING, giving great  
selectivity. ILLUMINATED SCALES marked with STATION  
NAMES as well as wave-lengths. SEPARATE SCALES for the two  
wave-bands. Operation of wave-change switch automatically discloses the  
correct scale (Long or Medium.) TONE-BALANCED L.F. Amplifier.  
Energised MOVING-COIL SPEAKER. Provision for using an external  
speaker in place of, or in addition to, the M.C. Speaker. SOCKETS  
FOR GRAMOPHONE PICK-UP. Beautifully finished BURR  
WALNUT CABINETS. For A.C. supplies only, 200/250 volts, 40/100  
cycles (25 cycle models 1 guinea extra). Available on H.P. TERMS.*



## CONSOLE TABLE MODEL

Chassis as Table Model,  
but with moving-coil  
speaker of even more  
powerful type. No exter-  
nal controls on front  
or sides.

Undistorted Output 2,250  
milliwatts. Current Con-  
sumption 60 watts. Dimen-  
sions 35" high x 15" deep x  
20" wide.  
Model AP.44. **35 Gns.**

*Easily carried by concealed  
handle which lies flush with  
top when not in use.*

Undistorted Output 1,600  
milliwatts. Current Con-  
sumption 60 watts. Dimen-  
sions 16½" high x 12" deep x  
13" wide.  
Model AP.38. **26 Gns.**

# Varley

PROP: OLIVER PELL CONTROL LTD.

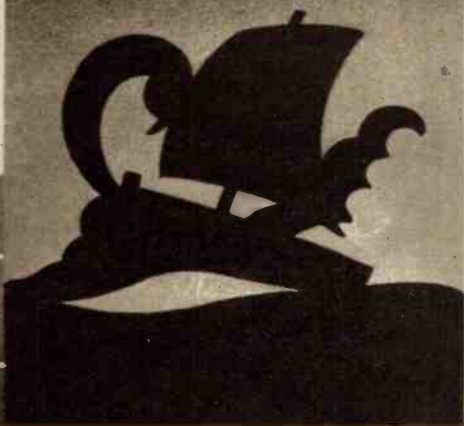

**. SELECTIVITY . SELECTIVITY . SELECTIVITY .**

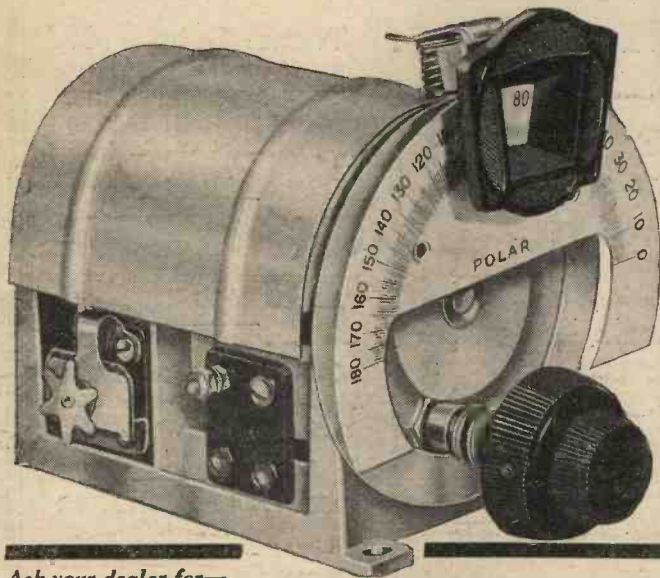

Ask your dealer for—

**POLAR STAR CONDENSERS**

WINGROVE & ROGERS LTD., 188-9, STRAND, LONDON, W.C.2.

No set is really up-to-date and able to meet modern conditions unless it incorporates Ganged Tuning. And no set can be of the highest efficiency unless this tuning is carried out with a Polar "Star" Ganged Condenser. Where a "UNIKNOB" is used, tuning is greatly simplified and, what is more important there is a marked increase in selectivity.

The "Uniknob" is matched to within  $\frac{1}{2}$  of 1% plus or minus 1 mmfd. and rigid die-cast construction maintains this accuracy under all conditions of use. A trimmer of 35 mmf. in parallel with the front section, is operated by a small knob situated concentrically with the tuning knob, allowing the finest adjustments to be easily made.

PRICE Including Cover

**19/6**  
2 x .0005

Write for Complete Polar Catalogue "N."

**POLAR "No. 2"**

The precise workmanship and amazingly low price has proved this to be the most outstanding condenser of its type. Fast and Slow motion, ball-bearing spindle, positive pigtail connection, one-hole fixing. Made in hard aluminium, with brass pillars for rigidity.

.0005 .00035 .0003

**6/6**



POLAR WORKS, LIVERPOOL.

**ONLY A PIX**



**WILL SEPARATE THEM!**

High power stations are cropping up everywhere. The overlapping problem is increasing daily. The interference of foreigners with home programmes has long baffled the best brains in Radio, until a young English engineer hit upon the brilliant idea of the PIX with the result that you can now increase the selectivity of your set and cut out all kinds of interference at the cost of only 2/-. With a PIX in your aerial you can also cut out your local station



and receive foreign concerts without interference. No wonder the PIX has swept the country—no wonder that more than 1,000,000 listeners are now getting better radio through PIX. Whatever your set: up-to-date, old-fashioned, battery or all mains, the PIX will "work wonders" for you as it already has done for countless others. Fix a PIX in your aerial to-day, and know what it is to get the best out of your set!

**THE BRITISH PIX CO., Ltd. (Dept. 302), 118/28, SOUTHWARK STREET, LONDON, S.E.1. Phone: Hop 1001-2.**

**LANCHESTER MOVING COIL PERM. MAG. "SUPER B"**

Immense Volume! Will accept 5 watts.

**HIGHEST SENSITIVITY**

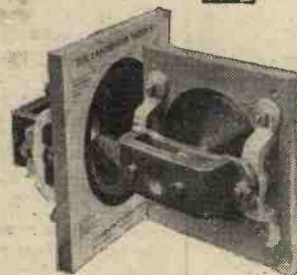

**PRICES:**

- SUPER B (as above) - £5 15 0
- SP. SENIOR - £3 3 0
- "Monitor" - £2 8 0
- "Junior" - £1 10 0
- "BoB" - £1 0 0

**SPECIAL MODELS FOR PORTABLES.**

- 4 Ratio O.P. Transformers (switch controlled).
- Mains Transformers and Eliminators.
- Battery Chargers, etc.

**Transformers and Cabinets extra.**

PUBLIC ADDRESS INSTALLATIONS.

**WRITE FOR FULL PARTICULARS AND ILLUSTRATED CATALOGUE.**

*Our Expert Advice is at your Service.*

**LANCHESTER'S LABORATORIES, LTD. SPRING ROAD, TYSELEY, BIRMINGHAM.**

# C. S. BARRETT,

4, UPPER JAMES ST., REGENT ST., W.1. 'Phone: Gerrard 1857

## XMAS GIFTS FOR YOUR FRIENDS

COSSOR MELODY MAKER S.C. THREE WITH VALVES £7 17 6  
17/6 Down. Balance of 11 monthly payments of 17/6.

EKCO A.C. 18-12 M/A ELIMINATOR £3 7 6

S.T. 400 KIT £4 17 6

K.B. PUP. COMPLETE WITH VALVES AND BATTERIES £4 10 0  
10/- Down. Balance of 11 monthly payments of 10/-

GRAHAM FARISH FILT 2/6

PIX SELECTOR 2/-

WATES VOLT METER 8/6

CHRISTMAS TREE LAMPS—22/6 set of 18. State voltage.

WATES DISTANCE SWITCH 9/6.

BLUE SPOT 59/6  
99 P.M. SPEAKER.

## SOLO KNOB THREE

COMPLETE KIT AS SPECIFIED

	s.	d.
1 Lissen Ganged Condenser Tuning Control Unit ..	14	6
1 Telsen Matched Screen Coil ..	8	6
3 W.B. Valve Holders ..	1	6
1 Graham Farish Snap H.F. Choke ..	2	0
1 Ready Radio 3-1 L.F. Transformer ..	8	6
1 Telsen 5-1 L.F. Transformer (Ace) ..	5	6
1 T.C.C. 0002 fixed condenser, Type S ..	1	3
1 T.C.C. 2 mfd. fixed Condensers, Type No. 50 ..	2	1
1 Graham Farish Horizontal Grid Leak Holder ..	6	6
1 Graham Farish 2 megohm Ohmite Resistance ..	10	0
1 Bulgin 10,000 ohms Spaghetti Resistance ..	1	0
1 Bulgin Base Board Fuse Holder and Fuse ..	1	0
1 Belling Lee 5 way Battery Cord ..	3	6
1 Coil of Glazite ..	6	6
Screws, flex, 2 wander plugs, etc. ..	1	0
2 Belling Lee Terminal Blocks ..	1	0
4 Belling Lee Terminals, A, E, L.S., L.S. ..	2	0
1 Ebonite Panel 12" x 7" Permco ..	3	0

Complete Kit Cash or C.O.D. Carriage paid £2 18 2

### ACCESSORIES

	£	s.	d.
1 Cossor 210 Det. Valve ..	7	0	0
1 Cossor 210 L.F. Valve ..	7	0	0
1 Cossor 215 P. Valve ..	8	9	0
1 Ediswan 105 v. Super Capacity H.T. Battery ..	1	1	0
1 Ediswan 2 v. 40 amp Accumulator ..	1	8	0
1 Ediswan 9 v. Grid Battery ..	1	0	0
1 Ormond Loudspeaker Type R. 452 with cabinet ..	1	9	6
1 Oak Cabinet ..	8	6	0

WRITE FOR 32 PAGE CATALOGUE OF 1933-4 RECEIVERS

LISSEN SKYSCRAPER KIT, COMPLETE WITH VALVES 70 STATIONS ON SPEAKER. 89/6.

KIT OF THREE VALVES. OSRAM, MULLARD, COSSOR or MAZDA. 1 H.F., 1 L.F., 1 Power. PACKED SPECIALLY. 22/9

K.B. 321 3 VALVE. A.C. ELECTRIC RECEIVER—100-250 VOLTS. £14 17 6. ULTRA SHORT-WAVE COIL, 6/6 EXTRA.

CELESTION P.M. SPEAKER 27/6.

ARGUS 3 KIT LESS VALVES AND CABINET £5 12 0.

ELECTRIC CLOCKS. FERRANTI. 30/-  
BULLE £3 3 0

# RESTORE lost voltage to your H.T. BATTERY

—and make it last at least 2 years —with the amazing REACTO Rejuvenator, which feeds your H.T. with L.T. current from a spare accumulator (which only needs charging once a year) until it returns to the original voltage. Also keeps your new H.T. at full capacity. Simple to connect. Produces clearer, louder tone. Eliminates parasitic noises. Your H.T. Battery gives constant voltage and lasts until it dries up. The—  
**MONEY-BACK GUARANTEE.**



Complete instructions in every box

# REACTO H.T. REJUVENATOR

Send P.O. for 3/6 to-day and start saving money right away. Obtainable only from the manufacturers:

REACTO APPLIANCES LTD. (Dept. XD), 28, Watling St., London, E.C.4



Scientific

**KNIFFY PIN**

**THIS XMAS.**

9 for 6d

Christmas Decorations, holly, mistletoe, those attractive, pleasing little coloured lights—

All these and many other things can be fixed in any position quickly and easily neatly, by simply pressing a Kniffy Pin into wood, wall or ceiling.

Ideal for hook-ups, temporary wiring to lamp standards, etc.

**KNIFFY PIN**

Kniveton Cable Works, Queensway, Ponders End - Middlesex

From your dealer, or send 7d. stamps to:

**Fix it with a 'KNIFFY'**

**LINK YOUR GRAMOPHONE TO YOUR SET WITH THE HANDCO PICK-UP**

Fits all Types

All the delights of a fifty-guinea radio-gram, for 1/- DOWN. Play your records through your loudspeaker. Volume to fill a Concert Hall. Booming bass instruments and high violin notes (impossible to gramophones) amplified with force, crystal clearness and absolute purity with Handco Electrical Pick-up. Guaranteed Cobalt Magnet. Nothing like it—amazing!

Terms: 1/- deposit, 2/- weekly (11/- in all), or 10/- with order.

P. W. HAND & Co., 284, High Holborn, London, W.C.1.

DESIGNS FOR APPARATUS FOR ANY RADIO PURPOSE, INCLUDING TRANSMISSION. OVERSEAS ENQUIRIES INVITED: ANY APPARATUS SUPPLIED. CONSTRUCTIONAL WORK UNDERTAKEN.

We undertake to solve your Problems, including obtaining Amateur Transmitting Licence. Whatever your difficulty, write us.

Charges: 3/- per query, four or more, 2/6 each, with diagrams. Radio Technical Agency (Dept. P.L.W.), 2, Westgate Chambers, Newport, Mon

**TRANSFORMERS.** Large quantity of genuine Ericsson Transformers. New and guaranteed. List price, 17/6 each. Ratios 2-1 and 4-1. Our price, 3/3 each.

**SPEAKERS.** Genuine "Six-Sixty" Speaker Units, brand new and guaranteed. Limited number only. Original cost, 6/6; to clear, 1/9 each.

**ETA.** General purpose valves. Type B Y 1814. List price, 5/6. Max. Fil. volt 2 Or., Fil cur. 0.12 amp. Mx. Anode vol. 150v., Ampl. factor 18, Imped. 14,000 ohms, Mut. cond. (slope) 1.3 m.a/v., Aver. anode current 3 m.a. (For 150v. anode current and -2.5 G.B. Limited number only for quick sale, each 2/6. Snap up these bargains whilst stocks last! Carriage paid U.K., cash with order.—Pioneer Radio Manufacturing Co., Ltd., Coptic Street, New Oxford Street, W.C. Museum 9607. Trade enquiries invited.

Everyone Recommends

**The SLEKTUN "COLT" L.F. TRANSFORMER**

The finest transformer ever made at such a low price. Specified for the latest sets. Ratios: 2:1, 3:1, 4:1, 5:1.

**4/9**

SLEKTUN PRODUCTS, LTD., 21, Douglas Street, Westminster, S.W.1

**CONSTRUCTORS' KITS.**

Mullard Radio for the Million A.C. 3 (SG., Det., Pentode), sealed carton, with valves. List, £6.10.0. at 72/6. Moving Coil Speakers, Rola (8) Type Midgets (U.S.A.), 8 1/2-inch cone, 90 volts D.C., 2,500 ohms, 40 m.a., with Multi Ratio Transformer, 17/-, 200/240 D.C., 4,000 ohms same price. Columbia (U.S.A.) Shon-soloid 8.G. 8 Radiogram chassis, valves (3 S.G., Det. L.F., push-pull rectifier) and speaker; guarantee 65 stations, 250-500, 1,000-2,000 metres, ready for incorporation in own cabinet, £15. Demonstrated if required. Carr. Paid. C.O.D., or call.—MAYFAIR RADIO, 31, George Street, Hanover Square, London, W.1.

# Charging Low-Tension Accumulators from D.C. Mains

*Practical Information by an Expert which will Enable any Amateur to Charge His Own Accumulators at a Minimum of Expense.*

By R. P. COLE

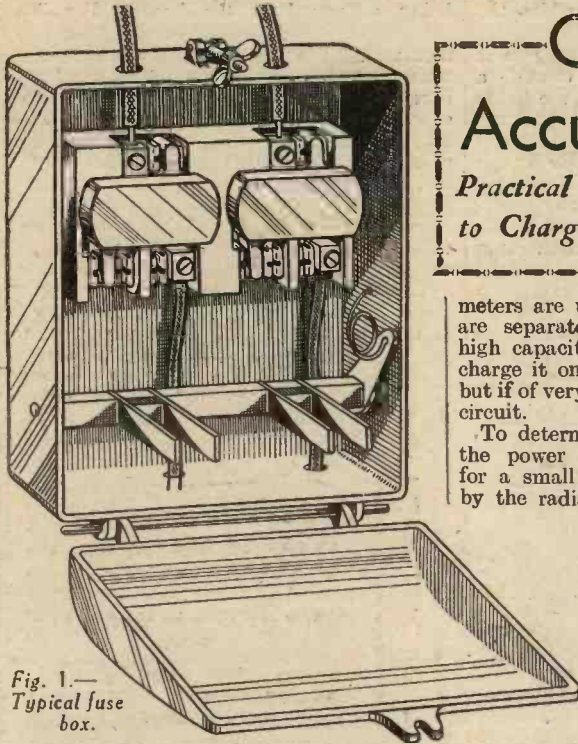

Fig. 1.—  
Typical fuse  
box.

**T**HERE are few listeners who have not experienced the annoyance of the L.T. accumulator running down during the reception of their favourite broadcast items, when the spare accumulator is at the charging station. A fully-charged accumulator always ready to hand would obviate this. In the upkeep of the set the charging of accumulators is a large item, and if this can be done without cost, it will appreciably cut down expenses. If your electricity mains are D.C. (Direct Current) you can charge your accumulator by passing through it the same electricity that lights your lamps or heats your electric radiators.

### Electricity Supply

It is quite a simple matter to ascertain whether your supply mains are D.C. or A.C. (Alternating Current) by inspecting the meter. There is usually a small plate on the meter giving this information, and also stating the voltage. In cases of difficulty, it is best to write to the supply company. Should the mains be A.C., you will not be able to use this method of charging. To charge the accumulator, the mains must be tapped at a suitable point. The point to be chosen depends on the current consumption of your lights and other appliances and also on the capacity of the accumulator or accumulators to be charged. The larger the accumulator, the higher is the rate at which it can be charged. The charging rate of an accumulator is printed on it, and it should be borne in mind that it is harmful to charge an accumulator at a higher rate than stated, but a lower rate will do no harm.

### Current Consumption

In order to find the current that is being used, a little calculation is necessary, unless you are fortunate enough to possess, or have access to, an ammeter. First of all, decide how many lamps or radiators are used at any one time. In some districts the lighting and heating mains are on the same circuit, but usually two different

meters are used, showing that the circuits are separate. If the accumulator is of high capacity, it will probably be best to charge it on the heating or power circuit, but if of very small capacity, on the lighting circuit.

To determine the current being used in the power circuit, inspect each radiator for a small plate giving the watts taken by the radiator. Add together the watts on all the radiators to be used at any one time, divide this total by the voltage of the mains, and you will then have the total current consumption of the radiators in use. If you use an ammeter, it is only necessary to put it in circuit with the radiators to read off the amperes direct. If this figure is higher than

the charging rate of your accumulator, it is unwise to charge the accumulator on the power circuit. In order to ascertain the current consumed by the lamps in the lighting circuit, the same principle is followed. Each lamp has stamped on it its rated consumption in watts. Add together the watts taken by all the lamps to be used at any one time, and divide the total by the mains voltage. This will give you the current consumption of the lighting circuit, which will probably be below the charging rate of the accumulator. Make certain that you will not be charging the accumulator at an excessive rate with all the lighting or heating apparatus on, according to which circuit is chosen. In order to charge the accumulator as quickly as possible, choose the circuit with the highest charging rate that is not above the charging rate of the accumulator.

### Connecting to the Mains

The next consideration is where to insert the accumulator. In order to make use of all the current being used the connection must be made in a wire that comes direct from the mains. Disconnect one wire from the main double-pole switch, after first switching this off on the side connected to the house wiring, not on the side connected to the electricity company's meter and sealed fuse (Fig. 1). It is not important which pole of the switch is disconnected, but it is safer to disconnect the side that is earthed. This can easily be

found by roughly connecting a piece of flex to one pole of the double-pole main switch. The other end of the flex is taken to a lamp holder. To the other connection on the lamp holder another length of flex is connected. After inserting a lamp in the holder, tap the loose end of the flex on the main water-pipe, taking care to hold only the

insulation. If the lamp does not light try the wire on the other pole of the switch. The earthed side of the mains is connected to the pole which does not light the lamp. Connect a piece of cable, about 1ft. long, similar to the wire removed from the switch, to the vacant connection. You should now have two wires showing, one connected to the switch and the other going to the lighting or power wiring system of the house.

### Polarity

Next, the polarity of the mains must be determined. The easiest way is with pole-testing paper. Full directions showing how to use this are given with the packet, which may be obtained very reasonably at most electricians. Failing this, place the end of the wires in a glass or china vessel containing water, at the same time taking care that the wires do not touch. Then, after switching on the main switch and any one of the lights or radiators in the house, as the case may be, bubbles will be observed coming from both wires, but the negative pole will bubble much more freely than the positive pole. Again switch off the main switch and carefully mark the wires. The positive pole by tying some red cotton round the wire, and the negative pole with black cotton.

You will now require a two-way single-pole switch, of the tumbler type, for preference (5 amp. switch for lighting circuit or 10 amp. switch for power circuit). Also purchase one switch block. Drill holes in the block to correspond with the switch connections, and thread each wire through the block before inserting them in the switch connections, as follows: Connect the negative wire to the common point and the positive wire to one of the other two connections, together with another length of wire long enough to reach to the position where the accumulator will stand while being charged (Fig. 2). This piece of wire must now be marked red for positive. Into the last connection a similar length of wire is inserted and marked black, being the negative pole. The switch block must now be fastened to the wall and the switch screwed securely to it.

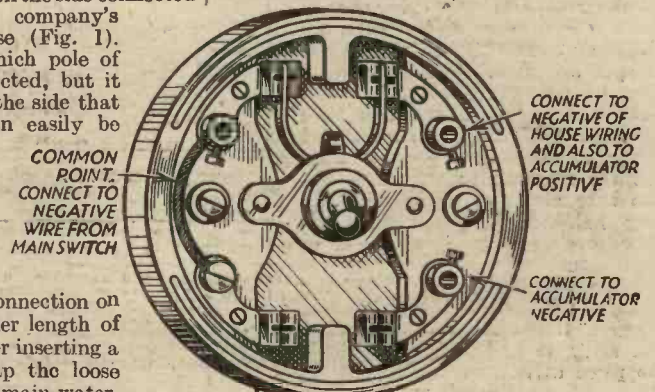

Fig. 2.—A two-way double-pole switch.

Connecting the Accumulator

After making certain that the loose wires are not touching, and are insulated from any damp walls or ground, switch on the main switch and also one of the lights or radiators. By switching the two-way switch up or down, it will be observed that the lamp lights with the switch in one direction only. Leave the two-way switch in the position in which the lamp lights and, after again switching off the main switch, connect the two wires securely to the accumulator to be charged. Positive wire to positive terminal and negative wire to negative terminal. Switch on the main switch, and switch over the two-way switch to the position in which the lamp previously went out. If all the connections have been correctly made, the lamp will now continue to burn, and the accumulator is being charged.

The accumulator should be stood on a sheet of glass to completely insulate it from earth. If the connecting wires are very long, they should be run through steel tube. After an accumulator has been charged, and if it is not desired to charge another immediately, the double-pole switch should be left in the position in which the lights continue to burn with the accumulator disconnected. The wires should be carefully fastened in a safe position, and not left hanging where they may cause an earth. It is also wise to insulate the exposed ends with insulating tape. The best plan to follow is to have two medium-sized accumulators of the same capacity

so that one may be charged while the other is in use.

If it is found that the charging rate is excessive even on the lighting circuit, a connection may be made using the lights on one floor or portion of the building only. In addition to the main fuse there are other fuses, connected usually in the supply to each floor of a house. It is easy to decide which fuse belongs to any particular part of a building by disconnecting one fuse and switching on all the lamps to find which do not light. A connection

being consumed in the house. For instance, it will take longer to charge in the summer than in the winter, as considerably more current is used during the dark evenings of the winter than on the long light evenings of the summer. The only satisfactory method of telling whether an accumulator is charged is by a hydrometer, and a reliable one can be purchased quite cheaply nowadays. Full directions are given with each. A slight overcharge will not damage the accumulator, but continuous undercharging will.

The level of the acid should be kept above the top of the plates, by the addition of distilled water only. Do not add acid unless some has been spilled, and then only diluted acid of the same specific gravity as that in the accumulator at the time. When

placing an accumulator on charge remove the vent to allow the gas to escape freely, and keep the terminals clean and covered with vaseline to prevent corrosion.

You will probably find that your accumulators will give you a much longer life, because some so-called charging stations are not so careful with your accumulator as you will be. Finally, a new accumulator should be given a long, slow and continuous charge, and for this reason the first charge should be given either by the makers or at a reliable charging station. Many accumulators, however, are now retailed already dry, charged and only need the addition of acid, when they are ready for use.

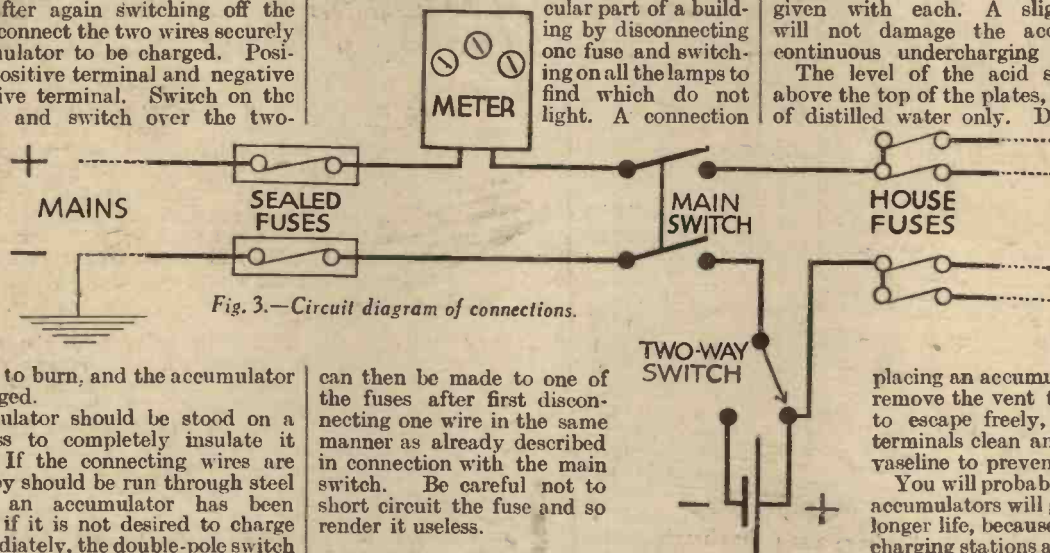

Fig. 3.—Circuit diagram of connections.

can then be made to one of the fuses after first disconnecting one wire in the same manner as already described in connection with the main switch. Be careful not to short circuit the fuse and so render it useless.

A Slow Charge

Owing to the fact that the accumulator is usually only being charged at a slow rate while the lights are burning, the charging process is slow. The time taken to charge an accumulator varies considerably and may be anything from a week to a month, depending on the size of the accumulator and the quantity of electricity

# A Simple Remote-Control Switch

By A. J. POTTS

BY means of this easily-made automatic switch a set can be conveniently switched off from another room. The materials used are not critical, and most constructors will probably have all that is required in the junk box, with the exception, perhaps, of the mercury, which should not cost more than three pence. First cut all the wood parts as indicated by E, G, F and D in the accompanying sketches. These will occasion no trouble if they are cut to proper size. The spindle hole and the chisel-shaped point of G should be carefully made, and the chisel edge must not be split or rough. The glass tube, C, is an ordinary flint tube, complete with cork. Insert this tube in a piece of cork, as shown, and then glue the cork to part G. Now put the mercury in tube and put two bare pieces of wire about 1 1/2 in. long half-inch into the tube on opposite sides, then insert cork to hold them in place. The end can be sealed with sealing-wax. Cut the piece of tin-plate from any old tin, shaping the claw end carefully, and screw it to the block F. Stick the piece of sponge rubber, B, on top of it. An old bell magnet, or a 2 in. length of a large nail wound

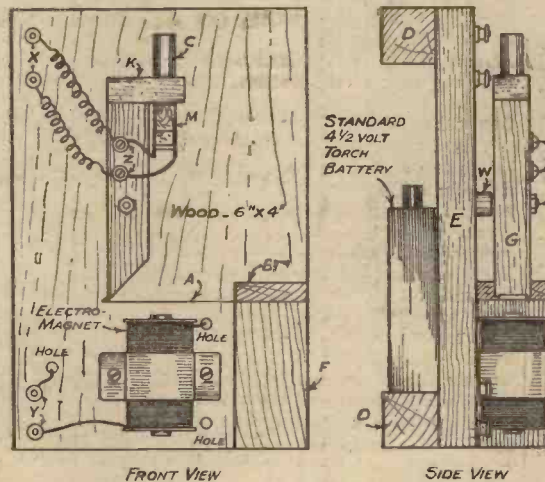

An easily-made remote-control switch.

with the necessary wire, will serve for the electro-magnet. This magnet is fixed by a strip of brass or copper as near to A as possible, but allowing sufficient movement for it to be pulled down in at the claw end. Now mount all the parts, terminals, etc., on the board E. The two terminals on G can be just screws and washers, and the spindle L a piece of threaded rod, with a collar at W. When this has been done, adjust so that the whole looks like the front view shown in the drawings. It should then be pulled down the part G will fall into a horizontal position. Then while G is down, connect the terminals X to Z, and leaving the leads slack. See that G falls easily. The remainder of the connections are as follows. One terminal Y to magnet, the other end of the magnet to one side of the 4 1/2-volt battery at the back, from the other battery strip to the other terminal Y.

That is all the connections for the relay. To connect up, undo the wire that goes from L.T.— on accumulator, and take a wire from each of these points to the terminals X. A bell-push is connected in the bedroom, to a double wire, and the other ends of this wire to the terminals Y. Place G in upright position and switch set on in the ordinary way.

What  
Better Gift  
than  
a  
**CELESTION  
SPEAKER**

For the music-lover there's no more acceptable Gift than a Celestion PPM Soundex Speaker. It is housed in a dignified figured walnut cabinet that will harmonize with any furniture scheme. Sensitivity and remarkable volume are its most outstanding features.

Those who insist upon true-to-life reproduction will appreciate the high standard of tonal quality. Price only 50s., including universal transformer.

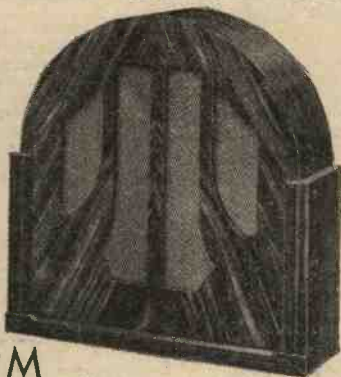

PPM  
SOUNDEX CABINET

Here is another very popular Celestion Speaker, the PPM 29 Chassis. It is the largest speaker in the Celestion range, and is without doubt an extremely efficient model. Tonal quality and sensitivity is greater than ever before obtained—gives tremendous volume. Price 77/6, including universal transformer.

Insist upon your local dealer demonstrating these two speakers.



PPM 29  
CHASSIS

Celestion Ltd.,  
London Road,  
Kingston-on-Thames.  
London Showrooms:  
106, Victoria St., S.W.1.



**IF YOU HAVE  
ELECTRIC LIGHT  
YOU NEED THIS BOOK**

**CONTENTS**

- RADIO POWER UNITS—and how to build them.
- NOTES ON A.C. POWER UNITS.
- OPERATING RECEIVERS ON D.C. MAINS.
- ABOUT T. C. C. ELECTROLYTIC CONDENSERS.
- ELIMINATION OF INTERFERENCE.
- FOUR T. C. C. POWER UNITS (A.C.) with full constructional details.
- ROTATING RESISTANCE CALCULATOR.

Only mains power can provide your set with that *constant* voltage essential to pure and powerful reproduction. Get a copy of this book and see how you can run your set off the electric light—how you can be *sure* of adequate power—always—how to dispense with costly and inefficient batteries. If you are on A.C. supply there are four power units described—one of which is suitable for your set. If you are on D.C. there is an informative chapter on D.C. apparatus. The book also includes a useful Rotating Resistance Calculator. Ask your dealer to-day or fill in and post this coupon.

**COUPON**

To The Publicity Dept., The Telegraph Condenser Co., Ltd., Walts Farm Rd., N. Acton, London, W.3.

Please send me a copy of your book "The Design and Construction of Radio Power Units," for which I enclose six penny stamps to cover cost and postage

Name.....

Address.....

Form 10/12/32

PLEASE WRITE IN BLOCK LETTERS

**T.C.C.**  
ALL-BRITISH  
**CONDENSERS**

# What we Found..

## COMMENTS ON COMPONENTS



### AERIAL SERIES CONDENSER

IT is a well-known fact that a small condenser, in series with the aerial, is a valuable aid to selectivity. Unfortunately, this slightly reduces volume, and is not always needed, either on normal or long waves. It is necessary, therefore, usually to fit two aerial terminals, one going direct to the coil, and the other to the condenser. The new Telsen condenser has been designed to overcome the necessity of the two condensers, and at the same time, to provide an adjustable condenser for selectivity purposes. The minimum capacity is .00006 mfd. The maximum is .0003, and the principal feature of this component is, that just after it reaches maximum capacity a small shorting switch is brought into operation, and so joins the aerial direct to the coil. This condenser may be attached to the panel by the usual one-hole fixing bush, and the price is 2s. 3d.

### THE BULGIN H.F. MAINS CHOKE

INTERFERENCE in its many forms, does not always get into the set via the aerial, but often through the medium of the mains unit. The special H.F. mains choke made by A. F. Bulgin and Co. is specially designed to stop H.F. currents arriving through the mains. The choke should be placed in one of the leads feeding the eliminator, with a condenser (about .01 mfd.) connected at either end, and the free terminals of the condensers connected to earth. The choke has an inductance of 40,000 microhenries, and a D.C. resistance of 120 ohms. There will thus be a drop of potential of only 1 volt for each 8 milliamperes carried. The instrument is housed in a green bakelite case, and has interlocked terminals. Its carrying capacity is 100 milliamperes. The cost is 7s. 6d.



The Bulgin Mains H.F. Choke.

### TAPPED OUTPUT FEED CHOKE

WHEN a pentode valve is employed in the last stage, it is often a difficulty to fit a really efficient output arrangement. Owing to the high impedance of the pentode valve the loud-speaker cannot obviously be included direct in the anode circuit, and, therefore, some sort of transformer or choke must be employed. Messrs. Lissen have developed a very interesting choke for this purpose, and this is provided with four terminals. Two are lettered L.S., and the remaining two bear the letters P and H.T. The internal wiring is simply that of a choke with a central tapping, this being taken to the L.S.—terminal, and one end of the choke is taken to the terminal marked P. The other end of the choke is joined to both of the remaining terminals. This ingenious arrangement permits of numerous different connections for the choke from a simple filter-fed pentode circuit, to a push-pull output choke. The inductance of this choke is 18 henries at 7 milliamperes, and only drops to 12 henries at 40 milliamperes, a really good characteristic. In view of the high current rating, there is no reason why the choke could not be employed also in eliminator or other smoothing circuits. The price is only 7s. 6d. and the usual Lissen bakelite case is fitted to the choke.

### BULGIN SCREENED SUPER-HET H.F. CHOKES

IT is not always realised that the H.F. choke has an important work to do, and the satisfactory functioning of a set is often marred because a poor choke, or an incorrect one, has been fitted. This is a super efficient instrument, each one being tested, and guaranteed to have the remarkably high inductance value

of 500,000 microhenries. It has no resonant points or "peaks" within frequencies corresponding to 100-2,500 metres, and gives a straight line curve within those limits—a performance really exceptional. The self capacity is but 1.5 micro-microfarads, it is fitted in universal mounting screening case, and costs but 6s. 6d.

### NEW CLIX SOCKET

WHEN a metal chassis is employed for a receiver there is very often a great deal of difficulty in fitting small plugs and sockets, owing to the arrangement of insulation in the small size in which such sockets are found useful. Lectro Linx Ltd., the makers of the well-known range of Clix components, have now produced for the home constructor an extremely neat and efficient plug and socket for this purpose, and it will be found to provide a most satisfactory solution to the problem. The socket is less than an inch long, and consists of a metal socket with the popular threaded and slotted end such as is employed in the Clix valve-holders. Around the upper portion of the socket is an ebonite casing, the upper quarter of an inch being just under half an inch in diameter, and the lower portion provided with a thread which requires a 1/16" hole in the chassis. This is a most convenient size of hole, and practically every home constructor possesses a 1/16" drill. The ebonite casing is finished in either red or black. The plug portion is on similar lines to the Wander Plugs, and makes a perfectly sound electrical joint, which will not give rise to noises if the set is subjected to undue vibration. The socket costs 2/6d., and the plug 1/6d. A full range of markings is obtainable.

### BRITISH GENERAL BAND-PASS UNIT

THE band-pass units produced by the British General Mfg. Co., Ltd., are of the non-screened type, as will be seen by the illustration. The two coils are mounted at right angles, the cylindrical formers carrying the short-wave windings only. Beneath the moulded base the long-wave windings are disposed on slotted disc formers, and for coupling purposes a .04 non-inductive condenser is required. This is not included in the unit. A very ingenious form of switching is fitted to the unit, and this consists of a moulded ebonite rod into which are fixed varying lengths of brass rod. Finger springs are arranged across the base, and rotation of the moulded rod interconnects the different sections of rod, and so provides the complete change of coil required for wave-changing. The separation of these coils is 4 kc/s., and the operating rod is provided for ganging. With each coil the makers supply a complete set of wiring circuits, in which is shown a receiver employing two of these units, one for the anode and one for the aerial. We have not yet had an opportunity of testing these coils, but as soon as we do so we shall give a full report of their performance. The price is 9s. 6d.

### THE CONCENTRIC AERIAL

IN the early days of broadcasting it was a generally-accepted axiom that every effort should be made to install at as great a height as possible, a nice long aerial; in fact the Postmaster-General authorised anything up to 100 feet in length! Later, with the advent of a larger number of stations and in particular, their increased power, the listener was recommended, if selectivity was desired, to cut down the length of the horizontal wave collector. Sensitivity, and especially selectivity, have been the aims of most designers of wireless sets and to-day, with the increasing number of super-power stations broadcasting in the ether, if good reception is to be assured, the aerial installation itself plays an

important factor. What is required is an aerial which shall be unidirectional or multi-directional and that it should be of a length which, although reaping full advantage of this quality, does not collect all signals and thus cause interference. Moreover, in many instances it is useful to be able to shorten the aerial. Experiments made with a vertical wire show that in most ways it is more efficient than the horizontal variety and may be made shorter, a good point in its favour. In the *Concentric Aerial*, under test, we found that these various points have been well covered; it is vertical throughout and has been reduced to the correct length for average requirements. Further, it can be shortened at will and so made still more selective. It consists of a multi-sectional tube, through which runs a rubber covered cable ending at the top with a specially wound spiral wire. The outer tube acts as a condenser and for this reason is insulated both from its window or wall support and from the internally carried cable. The capacity is controlled by shortening or lengthening the tube, as desired to suit the circuit of any individual receiver. This condenser action of the outer tube reduces the length of aerial wire found necessary in the past. With the sectional tube, a small base plate is supplied which must be screwed to any fixed wood or brick-work; if to the latter, it should first be attached to a suitable wooden support. To the base plate, two extending arms are bolted—all material is provided in the outfit—and the tube slipped through the arms and fixed with butterfly nuts. The tube sections may then be pulled out to the length desired, each section being held by a split pin. The aerial proper consisting of a continuous length of insulated cable is then brought direct to the receiver or to whatever aerial and earth switch you may possess. If, when the aerial is tried, insufficient selectivity is noticed, by simply removing a split pin and pushing one section of tube down into the next, you can shorten the aerial. For the purpose of a test the *Concentric Aerial* was installed in a congested area in the N.W. of London, a district in which most horizontal aeriels were badly screened. In this case, affixed outside an upper window frame it was well clear of both walls and roof. Tried in connection with various receivers, it proved itself, in every respect highly efficient and excellent results were obtained. Owing to its shape it can be erected anywhere, as it does not need the span required by a horizontal wire. In conjunction with a shortwave receiver, it was found of great value. The *Concentric Aerial* is supplied by the Radio Development Co., of 17, Crouch Hill, London, N.4. The complete outfit is sold at 21s. It can be unreservedly recommended.

**STARTING NEXT WEEK**  
EVERY ISSUE OF  
**"PRACTICAL WIRELESS"**  
will contain a  
**DATA SHEET**  
containing valuable information.  
**SEE PAGE 577.**

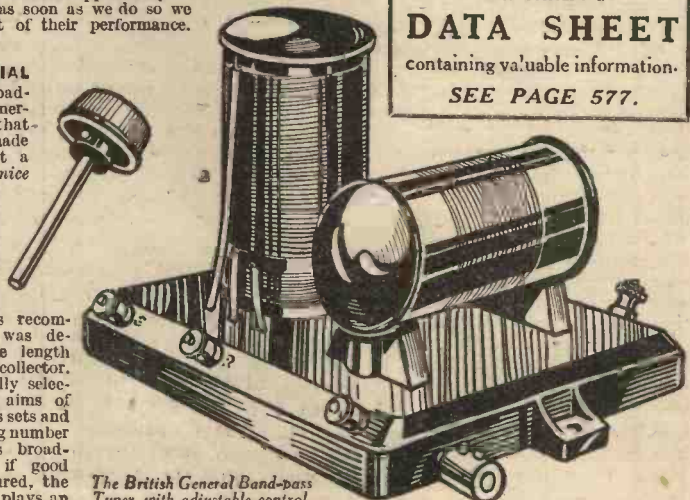

The British General Band-pass Tuner, with adjustable control.





### THE BEGINNER'S A B C OF WIRELESS TERMS

#### Anode

A term used to denote the positive pole in certain electrical apparatus, and more particularly to the positive electrodes of valves.

The anode, also called the *plate*, of a valve is a little metal case or sheath which you can see if you look through the glass of a fairly "clear" valve (see Fig. 1). Inside the anode are the other "business" parts of the valve—

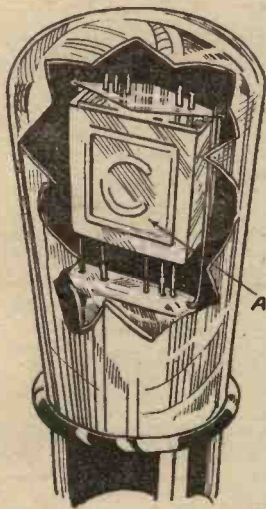

Fig. 1.—Valve cut away to show anode.

the filament and the grid or grids, but the anode is always the outside one. Although a sheet metal plate is the usual form of anode in a valve, other types have been tried from time to time. One particular make of valve which flourished some years ago had an anode which looked similar to the grid, that is

to say, it consisted of a spiral of wire like a spring. Another well-known valve used in mains sets has a cylindrical anode of metal gauze. This is found to dissipate the heat better than the plain type. Perhaps you may have noticed that, when your wireless set is working, the power valve, and also the rectifier valve, if you have a mains set, gets quite hot. This is not due to the heat from the filaments, which is really very slight, but is due to the anodes getting hot. No doubt you know that electrons (minute particles of negative electricity) fly off from the filament or heater which is placed inside the anode of a valve. Well, it is these electrons hitting the anode which make it get hot, and that is the reason why some anodes like the one just mentioned are specially designed.

Rectifier valves of the full-wave type, which are used in A.C. mains sets and in mains units, have *two* anodes. These are usually placed side by side. The reason for this is because the rectifier valve has to deal with alternating current which moves first in one direction and

then in the other. (See "Alternating Current.") One instant one plate acts as an anode, and the next instant, when the current has reversed, the other one becomes the anode; so that, although there are two anodes in the valve, they do not both function at the same instant of time.

#### Anode Bend Rectification

This term refers to a particular method of using a detector valve. The usual way

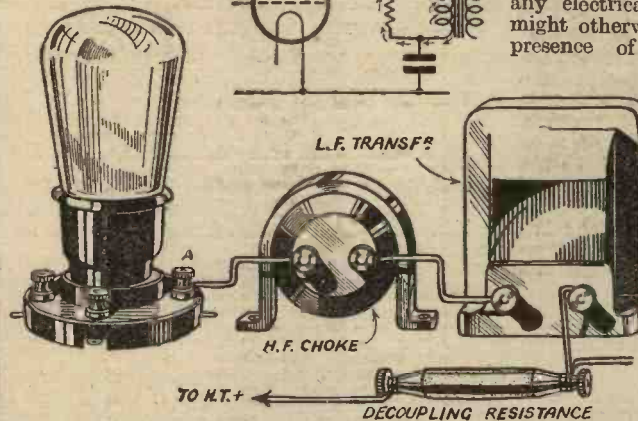

Fig. 2.—(Above), arrows show typical anode circuit. (Below), the same thing shown pictorially.

of connecting up the detector valve is to use a grid-leak and condenser. This is known as *grid rectification*, but with the less general method of *anode bend rectification* no grid leak is used, and the grid is usually negatively biased. This method of detection derives its name from the fact that the *bend* of the anode current-grid voltage curve is used.

#### Anode Circuit

That part of the circuit between the anode and the high-tension supply. Fig. 2 shows a typical anode circuit. The valve is a detector, and in the anode circuit are included an H.F. choke, the primary winding of the L.F. transformer, and a resistance for decoupling purposes.

#### Anode Converter

A small electric machine which combines the functions of an electric motor

and a dynamo. It is used to supply high-tension current from a low-tension source. In other words, it enables you to get H.T. current from an accumulator, and so does away with the need for an H.T. battery. The accumulator is connected to the anode converter, which then commences to run like an ordinary electric motor such as is used in electric fans and vacuum cleaners, etc. It has this difference, however. Instead of using the power developed to work a fan or sweep the carpets, it is converted into electric current at a high voltage suitable for supplying the anodes of your valves. The whole apparatus, including the starting resistance, the converter itself, and the necessary smoothing devices for the elimination of hum, is housed in a stout metal box. This forms an effective shield against any electrical disturbances which might otherwise be caused by the presence of an electric motor working near the receiving set.

#### Anode Current

The current flowing in the anode circuit of a valve that is in any part of the circuit between the anode and the high-tension supply. Although this is the accepted definition of the anode current,

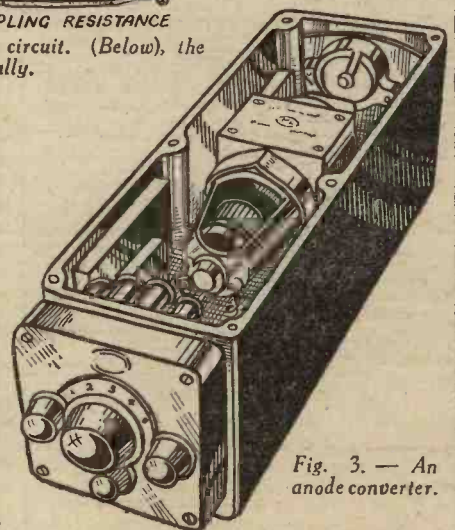

Fig. 3.—An anode converter.

it does not mean to say that when it leaves the anode circuit it vanishes. Actually it commences with the passage of electrons from the filament of the valve to the anode and continues through the anode circuit and the H.T. battery back to the filament. Thus it is flowing round and round the whole time the valve is working. Where the anode current comes from is the H.T. battery or mains unit. If you wish to measure the anode current of one valve only, the meter should be placed in the anode circuit of that particular valve. If on the other hand you wish to measure the total anode current of all the valves in your set, you must place the meter in the negative lead to the H.T. battery or mains unit, since the anode current of each valve has to pass through that way.

#### Antenna

Another name for the aerial.

#### Atmospherics

Natural electrical disturbances which cause interference with reception, usually in the form of "crackles" and "crashes" in the loud-speaker. These noises are due to electro-magnetic waves by flashes of lightning and similar phenomena. In some parts of the world, especially in the tropics, where the air is often highly charged with electricity, atmospherics are very persistent, but in this country they are usually only heard during thundery weather. One reason why atmospherics are so troublesome is because, unlike the waves from a broad-

casting station, they are not restricted to any particular waveband, and therefore it is impossible to tune them out.

A very good imitation of atmospherics is sometimes produced by the use of an old H.T. battery or a "burnt-out" transformer, and disturbances due to these causes are often blamed on to atmospherics. Atmospherics are also known as "Xs" and "strays."

#### Audio-frequency

This term, when applied to an electric current, means that it oscillates at the same frequency or speed as do sound waves. Such a current passed through a loud-speaker would produce audible sounds. If, however, the frequency were gradually increased, a rising note would be produced until it was of so high a pitch that it was inaudible to human ears. The frequency would then no longer be an audio-frequency, since it would be outside the range of audibility. Frequencies between 30 and 10,000 cycles per second are usually considered to constitute the range of audio-frequencies. The lowest note of the piano has a frequency of 26 cycles, or beats, per second, and the highest a frequency of 4,096.

#### Audio-frequency Transformer

Any transformer used in the audio-frequency, or, as it is more often called, low-frequency circuits of a set. L.F. interval transformers, output transformers and the transformers on some loud-speakers are all audio-frequency transformers. The particular require-

ments of an audio-frequency transformer are that it shall be capable of dealing with all frequencies between that represented by the lowest musical note and that of the highest note likely to be met with. Sometimes, however, a transformer is designed to over-emphasize some part of the musical scale when that

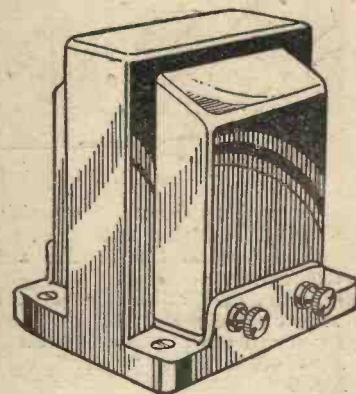

Fig. 4.—An audio frequency transformer.

part has not been previously magnified to the same extent as others.

Usually an audio-frequency transformer consists of two separate windings of very fine insulated wire wound round an iron alloy core. (See "L.F. Transformer.") Where only one winding is used it is known as an auto-transformer, the details of which are explained under that heading.

TO the layman it may appear rather strange that a wireless set has to be "tuned" to get a particular station. "Why" you ask is there this need for tuning, and what does all the talk about tuning coils, tuning condensers, and tuned circuits mean? "When I speak to anyone over the telephone I don't have to tune it in. Why should I tune in the wireless?" Well, the answer is that it is a question of selection. Of course, with the telephone the tuning-in is done by the operator when she puts the call through to you. Your bell rings, and you take up the receiver and speak. There is no need for you to tune-in, that is to say, there is no need to select the voice of the person desiring to speak to you out of hundreds of others, because his is the only transmitter connected with your receiver. However, were the operator to make a mistake and connect several other subscribers all to your receiver it would be quite different—there would be chaos!

#### A Means of Selection

Well, now this is the sort of thing that would happen in wireless if there were no tuning. You see wireless waves are literally "broadcast." They are sent out in every direction from hundreds of stations at the same time, and the only way to avoid receiving the whole lot at once when you switch on your set is by means of tuning. The transmitting stations are each carefully tuned, and so must your receiver be.

A tuned transmitting station may be likened to a tuning fork. You strike the fork and it vibrates at a certain speed, or frequency as it is called, and this gives out a certain musical note. It does not

## WHY YOU HAVE TO TUNE YOUR SET

By W. B. Richardson

vibrate at all frequencies, and so give out a medley of noises, but only at one particular frequency giving out one clear note.

In the same way the transmitting station gives out waves vibrating at one frequency only. Now, if another tuning fork of exactly the same characteristics is brought near the first, while it is still vibrating, the second one will commence to vibrate in sympathy. It has "tuned-in" to the first fork. The second fork may be likened to your receiver. If, however, a dissimilar fork, that is one made to vibrate at a different note, were brought near the first it would not respond in this manner. It would remain "dead."

#### A Question of Resonance.

In a similar way your receiver will not resonate in sympathy with the transmitter if it is not tuned to the same frequency. This is where the power of selection comes in. You cannot receive any station unless you tune in to it. Another example of resonance with which everyone is familiar, and which provides a further analogy to the tuning of wireless apparatus, is the instance of a pile of plates, or a cup and saucer on the sideboard which commences to vibrate or "buzz" when a lorry passes down the street. What happens here is that the vibration of the lorry chances to coincide exactly with the natural vibration period of the loosely-piled plates. As soon as

the lorry passes the plates "tune-in" to the particular vibration emitted.

The case of the radio transmitter and receiver is very similar although, of course, we are not dealing with sound waves, but with the much more rapidly vibrating electro-magnetic waves. If a receiving set is tuned until it has the same characteristics as the transmitter the latter will set up similar oscillations in the receiver, so that the two will be in resonance.

#### Coils and Condensers

Tuning coils and condensers are the practical apparatus necessary to limit the radiations from the transmitter to one particular frequency, or, to be quite correct, to one narrow band of frequencies, and unless the receiving set has similar coils and condensers to tune it to that same band of frequencies it will not pick up the signals sent out. This may sound a little complicated due, perhaps, to our use of the word "frequency." If you are more familiar with the term "wavelength" substitute that wherever you see "frequency" used, and you may grasp the meaning more easily. The two terms are not synonymous, but have a definite relationship so that in this case they can be interchanged. Actually "wavelength" means the distance between the crest of each transmitted wave, whereas "frequency" means how many pass a given point in a second.

All transmitters are not carefully tuned to transmit only over a narrow band of frequencies. Some, such as those employed by ships at sea, are often the reverse, and are what is known as "flatly" tuned. This means that you can tune them in easily since you can hear them over a wide range of your tuning dial.

**DARIO IS RADIO!**  
 Full range of Valves  
**2 VOLT,**  
**A.C. & D.C. MAINS**  
 Prices from  
**5/-**

**EFFICIENCY & ECONOMY**



Dario Valves are constructed with the most up-to-date technique in valve manufacture. Second to none in performance and sturdiness. In the exceptionally efficient range you will find types to suit every stage of your Receiver. If you want to obtain the best results and regain the original purity, crispness and volume of your Receiver at the MINIMUM EXPENSE, you must fit Dario Valves—then you are assured of the highest possible standard of reproduction. You can buy Dario Valves with every confidence because they are guaranteed non-microphonic.

Obtainable from all good Radio Dealers

**DARIO VALVES**

*Best way to all Stations*

**FREE**

We shall be pleased to send to "Practical Wireless" readers (on receipt of this coupon) the illustrated Dario Valve Booklet together with a free Valve Inquiry Form.

Name .....

Address .....

IMPEX ELECTRICAL, LTD., 338 High Road, Leytonstone, London, E.11.

**STUDY AT HOME**

**YOU CAN HAVE A COLLEGE TRAINING IN ALMOST ANY CAREER FOR A FEW SHILLINGS MONTHLY**

**IN YOUR SPARE TIME**

**LET ME BE YOUR FATHER**

Unless you are in touch with all branches of industry you cannot see the possibilities of employment, but with our gigantic organisation we are in touch with every sphere of activity, and we know that in many trades and professions there are more vacancies than there are trained men to fill them.



*J.B. Bennett*

**WE DO NOT PROFESS TO ACT AS AN EMPLOYMENT AGENCY, BUT WE CERTAINLY ARE IN A POSITION TO GIVE FATHERLY ADVICE ON ALL CAREERS AND THE POSSIBILITY OF EMPLOYMENT THEREIN.**

We teach by post all branches of the following vocations, and specialise in all examinations connected therewith. Our advice is always Free.

**THE MOST SUCCESSFUL AND MOST PROGRESSIVE CORRESPONDENCE COLLEGE IN THE WORLD**

- Accountancy Examinations
- Advertising and Sales Management
- A.M.I. Fire E. Examination
- Applied Mechanics
- Army Certificates
- Auctioneers and Estate Agents
- Aviation Engineering
- Banking
- Boilers
- Book-keeping, Accountancy and Modern Business Methods
- B.Sc. (Eng.)
- B.Sc. (Estate Management)
- Building, Architecture and Clerk of Works
- Chemistry
- Civil Engineering
- Civil Service
- All Commercial Subjects
- Commercial Art
- Concrete and Structural Engineering
- Draughtsmanship. All branches
- Engineering. All branches, subjects and examinations
- General Education
- Heating and Ventilating
- Insurance
- Mathematics
- Matriculation
- Metallurgy
- Mining. All subjects
- Mining, Electrical Engineering
- Motor Engineering
- Municipal and County Engineers
- Naval Architecture
- Pattern Making
- Police. Special Course
- Preceptors. College of Pumps and Pumping Machinery
- Radio Reception
- Road-making and Maintenance
- Salesmanship
- Sanitation
- Secretarial
- Shipbuilding
- Shorthand (Pitman's)
- Structural Engineering
- Surveying
- Teachers of Handicrafts
- Telephony and Telegraphy
- Transport
- Weights and Measures "Insp."
- Wireless Telegraphy and Telephony
- Works Managers

If you do not see your own requirements above, write to us on any subject

**DO NOT DELAY**  
 THERE MAY BE CHANCES FOR YOU TO-DAY FOR WHICH YOU MAY BE TOO LATE TO-MORROW. EVERY DAY COUNTS IN A MAN'S CAREER.

**IT COSTS NOTHING TO INQUIRE**

WE TEACH BY POST IN ALL PARTS OF THE WORLD  
 Also ask for our New Book—FREE OF CHARGE

**THE HUMAN MACHINE**  
 Secrets of Success.

Note Address Carefully:  
**THE BENNETT COLLEGE LTD.**  
 (Dept. 192)  
**SHEFFIELD**



(Dept. 192)

# OUR SHORT WAVE SECTION



IN the days before the B.B.C., it was a commonplace to recommend anyone newly interested in radio to learn the morse code; there was not much speech to be heard and, as they used to say, "knowledge of the morse code will increase the enjoyment you obtain from your apparatus a thousandfold." Nowadays, however, nobody ever proffers this advice, and not one listener in ten thousand knows anything about the code or feels any inclination to make its acquaintance. This is most definitely a loss for them, because the old saying still holds true, especially for the short-wave enthusiast, and the man who knows morse often finds the broadcast programmes very dull indeed compared with the entertainment and excitement he can derive from the elusive dots and dashes.

As anyone who has tried it will testify, short-wave reception is far the most exciting side of radio, and has the further recommendation that much may be accomplished with very little apparatus; but really to get the last ounce of satisfaction from it one must know the morse code, for this reason. Scattered over the world are something like 50,000 transmitting stations owned and operated by amateurs on the short waves, of whom probably 49,000 use the morse code exclusively; and because their transmissions are often most interesting, it is very well worth while to learn the code in order to be able to receive some of them. When you hear a broadcasting station, even if it is 10,000 miles away, you always have the feeling that, with 20 kilowatts or more input, it ought to get out anyway, but when an amateur in the middle of Australia or the West Coast of America comes in, and you know he is probably using no more than a thousandth part of this power, it all becomes very much more impressive. And then, when you go on to realize that he is very much like you, with the same difficulties in finding the shillings or dollars to pay for his apparatus, with his transmitter in one corner of the living-room, ticked off by his wife for his "messy wireless rubbish," even as you are, your heart warms to him as it can never do to the impersonal officialdom of a broadcasting company, be it never so courteous in acknowledging your reports of reception. In short, there is a "kick" to be had out of this amateur radio that nobody ever got from listening to a broadcasting station, but it is a "kick" that is known only to those who can read morse.

### Short-wavers' Activities

The purpose of this article, however, is not so much to dilate on the joys of amateur radio, or "ham" radio as its devotees call it, but to describe the conditions under which the transmitting amateur works, and the kind of things he does. The transmitting amateur is not so much known to listeners

### Amateur Short-Wave Transmission

By K. E. B. Jay.

now as he was a few years ago; once upon a time his transmissions of speech and music on 200 and 440 metres were a popular supplement to the meagre broadcast fare available, and when these wavelengths were closed to the amateur and he began to discover the potentialities of the hitherto despised short waves by working immense distances on very low power, he was a good source of "copy" to the daily press; but now that his accomplishments are less spectacular and there is plenty of broadcast music available, he is less in the public eye: in spite of this, however, the number of transmitting amateurs in the world increases daily.

The position of amateur radio in the wavelength spectrum was first internationally officially stated in the Washington Radio-Telegraphic Convention of 1927, when the following bands of wavelengths were allotted to be used by transmitting amateurs throughout the world:—

- 150.00 to 175.00 metres or 1,715 to 2,000 kilocycles;
- 75.00 to 85.70 metres or 3,500 to 4,000 kilocycles;
- 41.10 to 42.90 metres or 7,000 to 7,300 kilocycles;
- 20.83 to 21.43 metres or 14,000 to 14,400 kilocycles;

- 10.00 to 10.71 metres or 28,000 to 30,000 kilocycles;
- 5.00 to 5.36 metres or 56,000 to 60,000 kilocycles.

This is not to say that amateur radio did not exist before 1927; amateur transmissions had been made almost from the time of Marconi's first experiments and, in fact, the bands of wavelengths available before 1927 were much wider than the above. In 1927, however, the transmitting amateur was recognized internationally, and not merely by a few governments and ignored or prohibited by others. The provisions of the 1927 Convention, when they came into force in 1929, did cramp amateur work considerably, but the ingenuity for which amateurs are famous, combined with improved technique, has enabled more, rather than less, work to be done than ever before.

### U.S.A. and Canadian Experimenters

Although wavelengths were fixed internationally, however, other details were left to individual governments, with the result that some countries prohibit amateur operation altogether, and the encouragement given in others varies very greatly. In the United States the government gives the greatest liberty to its amateurs, who are permitted to use powers up to 1 kilowatt, and to transmit any kind of personal message for themselves or anyone else. In this country, on the other hand, power is limited to 10 watts unless special permission is obtained to use 50 or a 100 watts (for which privilege a considerable extra

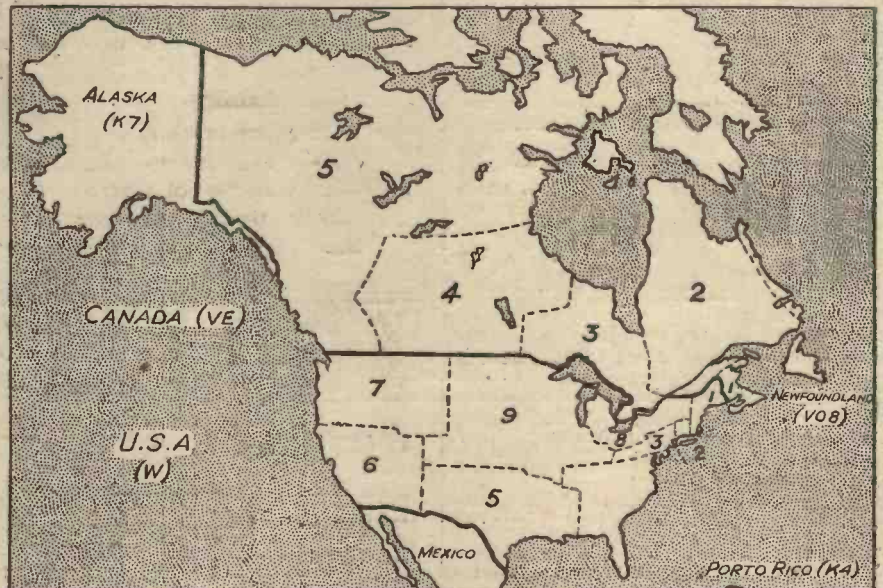

Fig. 1.—Radio map of Canada and U.S.A.

(fee is charged), and no messages may be handled for third parties, the intention being to make the amateur strictly an experimenter. Which brings me to another point. In Great Britain and most European countries the would-be transmitter must justify himself before the licensing authorities by showing that he wants his licence for experimental purposes, and submitting a programme of experiments; one might say that he is regarded as something of a scientist. In the U.S.A. and Canada, however, the only requirements made of the intending amateur are to pass a fairly simple examination in transmitting and operating procedure and show that he can read morse at ten words per minute (a similar test at twelve words per minute is imposed in England): the licensee is then encouraged to transmit and relay personal or business messages for anyone who cares to entrust him with them, without accepting payment for his service, of course; in short, he is regarded as a telegraph operator rather than a scientist. Needless to say, these divisions are by no means watertight; there are many European amateurs whose experiments, to say the least, are likely to be of little scientific value, and there are, likewise, many Americans whose major interest is in trying out various circuits or ideas of their own; but such is the basis of issuance of licences and shows the general aims of the amateur.

**Call Signs**

Now a word about call signs. The identifying call sign issued to any transmitting station by the licensing authorities is no mere haphazard collection of letters, but conveys definite information to the hearer about the nationality and class of station that owns it. Commercial stations have call signs consisting of three, four or five letters; three-letter calls are issued to fixed land stations, four-letter to mobile and ship stations, and five-letter to aircraft. The Washington Convention of 1927 allotted combinations of letters to its various signatory countries; thus, all calls beginning with G and M are British, while American stations may have calls beginning with K, N or W, German with D, French with F, and so on. Smaller countries may not be allotted a complete letter; Belgium, for example, has available only those combinations of letters between ONA and O'YZ, while Denmark has from OUA to OZZ. Amateur calls are distinguished from others by including a number as well as letters: the first letter or letters indicate the nationality, then comes the number, and then more letters, usually two or three, but sometimes only one. Thus it is possible, on hearing an amateur, immediately to identify his country, and in certain cases the province or part of the country in which the station is situated. In Great Britain the number in a call sign, which may be either 2, 5 or 6, is allotted arbitrarily, but other countries are often divided into districts, and the district indicated by a number. In Figure 1 is a map of Canada and the United States which shows the various districts into which these countries are divided: among other countries following this plan are Australia, New Zealand, Finland and Sweden. If, then, we hear a station with the call sign W6MMM we know at once that it is situated in one of the Western States of America, probably California; K6MMM, however, would be in Hawaii, since K in American amateur calls is reserved for stations in American possessions outside the U.S. itself. In a similar

(Continued on page 626.)



**Dubilier  
Condensers  
chosen by  
"CLARKE'S  
ATLAS"  
for  
dependability**

Mr. Clarke, of Messrs. H. Clarke & Co. Ltd., the famous manufacturers of ATLAS Radio Products, writes:—"In every case I have found your products to be most satisfactory."

Messrs. Clarke & Co. Ltd. have made certain of obtaining persistent results with their famous "Atlas Receivers" by incorporating Dubilier Condensers. With no other Condensers could they be so sure of getting the same absolute dependability.

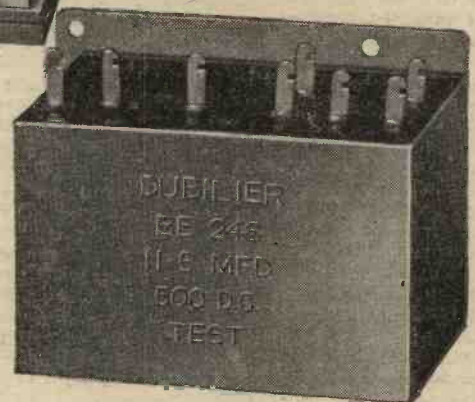

Constructors who have used them are equally enthusiastic about their performance. The number of returns is negligible, that is why Dubilier prices are always competitive. In the long run it will cost you far less to get satisfaction if you buy Dubilier Condensers.

# DUBILIER CONDENSERS

**DUBILIER CONDENSER CO. (1925) LTD.  
Ducon Works, Victoria Road, North Acton, London, W.3**

Distributing Agents for Irish Free State: KELLY & SHIEL LTD., 46/47 Fleet Street, Dublin, C.4



# Practical Letters

from

## Readers.

The Editor does not necessarily agree with opinions expressed by his correspondents

### Great Minds Think Alike!

SIR,—My attention has been drawn to page 437 of this week's issue of your journal on which a drawing is shown from a Mr. Houghton, of Preston, Lancs., regarding an "Earth" tube of special construction. I beg to inform you that the method of soldering an earth lead wire to the bottom of the tube in a block of solder or lead so as to obviate screwed terminals for attaching earth lead wires to, and thus prevent corrosion, is fully protected in my Master Patent, No. 337,866, granted to myself in 1929. In justice to myself, and to the Licenceses of my Patent, Messrs. The Garthbek Patent Aerial Co., Renshaw Street, Liverpool, I will be much obliged if you will make these facts known as early as possible. With congratulations on your interesting journal.—K. T. HARDMAN (Birkenhead).

### Points About Tuning

SIR,—I have been reading PRACTICAL WIRELESS now since No. 1 and I must say it is the best wireless magazine on the market for the amateur radio fan; keep up the good work, and more photographic supplements please. By the way, did you notice the mistake made by Mr. G. Twining in his article, "Points about Tuning," in PRACTICAL WIRELESS dated the 19th inst.? He states that wireless waves travel at the rate of 186,000 feet per sec., whereas this should have been 186,000 miles per sec.; perhaps it was only a printer's error.—E. NASH (Stoke Newington).

[Of course, it was a misprint.—ED.]

### Set With Old Type Plug-in Coils Wanted

SIR,—I note that you invite suggestions in PRACTICAL WIRELESS, so I venture to make one. Can you give us a good selective set using the old plug in coils, either a two or three valve set, that will bring in at loud-speaker strength some Continentals as well as English transmissions. There must be thousands of listeners (who have heaps of coils) and cannot afford to buy any of the new coils now on the market these bad times. I am sure it would be a great boon to them if you could do so, for there is not a wireless paper that caters for such amateurs, for in all the new sets published you have to spend £2 to £3 before you can start.—A. BEDDING (Clapham).

[We hope to publish something on these lines in the near future.—ED.]

### A Reader's Suggestions

SIR,—I have waited for your paper to get thoroughly into its stride before sending any criticism; and now—here goes.

First and foremost, you will be anxious to please the majority of your readers. The letters already published are some indication, but there are thousands who do not write, either through laziness, inability, or an idea that it would serve no purpose. This is my first letter to a wireless journal, and I know many fans who have not yet sent their first. Inquiries amongst these suggest that the majority have little technical knowledge; and your "Beginner's Supplement" and simple explanatory articles are what are required, above all. There is one drawback to these, however. They are necessarily somewhat disjointed. Might I suggest that much illumination would be shed by an article (or series) in which an imaginary expert visits a novice's home where an elementary "straight 3" is fitted; points out the defects of the set; helps the novice to re-build the set as S.G.—Det.—Pent.; and in doing so explains the function of each component lucidly. I think I am right in saying that there are very few readers with money for new components in these days. Consequently, a new set every month leaves them cold, unless it is possible to use existing parts. Further, in spite of what some of your recent correspondents say, battery sets predominate, much as their users may wish they had mains sets. Still another point. Most of us tinker with our sets for the love of tinkering, and because only a few tools are required. But when it comes to cabinet making we fight shy; for, after all, numerous tools plus a "bent" for the work are essential to success in this direction.

### CUT THIS OUT EACH WEEK

## DO YOU KNOW?

—THAT the flow of current is always from negative to positive, as the positive element is always short of electrons.

—THAT when resistances are joined in series the total resistance is the sum of the resistances.

—THAT when condensers are joined in series, the total capacity is not the sum of the condensers, but the reciprocal of the sum of the reciprocals.

—THAT an electrolytic condenser of given capacity is better for smoothing than an ordinary condenser of the same capacity.

—THAT there are, in process of perfection, entirely new methods of tuning, in which no variable condensers are employed.

—THAT ebonite has a dielectric strength four times as great as that of glass.

—THAT a pick-up may be joined to the grid circuit of an anode bend detector by including it in series with the biasing battery.

Wishing your paper a long life and a useful one.—W. B. BOTHAM (Ardwick).

### Entertainment Articles Wanted

SIR,—Might I join other readers on your correspondence page, and mention that I have gone over to your paper from another journal which, after many years, has forgotten how to be instructive and entertaining. Your journal gives more for the money; more practical parts, and more technical articles. At the same time, my only regret for my old love is that you give us so little news of studios and artists. The article "In the B.B.C. Studios" strikes the right note, and in my humble opinion you could do with more of this sort of matter. Wishing your journal every success.—E. BROWN (Leyton).

### An Appreciation from Bolton

SIR,—My club have asked me to convey their appreciation of such a splendid paper as PRACTICAL WIRELESS has turned out to be. We are sure if the paper continues to publish such valuable information in the future, as in the previous numbers, it is sure to be a huge success. We are beginning a season of set designing and lectures, and the latter will be conducted by prominent men in the Radio world. Any new members will be heartily welcomed. Again, let me thank you on behalf of the Bolton Y.M.C.A. Radio Club for filling a long felt want in Radio literature.—J. CLAYTON, Asst. Sec. (Bolton).

### More Articles on Small Sets Wanted

SIR,—I have followed with interest the issues of PRACTICAL WIRELESS, and the many letters of appreciation which have been published from week to week. The only thing which I would like to draw your attention to, is that I do not think enough time is given to the building of small sets. A lot of people would not think of having a "one-valve" set because they say that they are no good. This is not so. I have had a "one-valver" for the last year and it has given very good service indeed with four pairs of headphones. I have "logged" over 50 stations which can be received with very good results, and no doubt many more could be received if time were given to the job. The other point about a one-valve receiver is this. The cost is very low compared with the big three and four-valve sets of to-day. Why not start with a one-valve set and add the parts bit by bit so that the cost of a two or three-valve set is spread over a greater period? The costly sets are all very well for those who can afford them, but what about the working man who has not the ready cash at his disposal?—J. SHEPPARD (Taunton).

(Continued on page 623.)

# Autokoil

THE NEW ALL-WAVE TUNER that simplifies set building and increases selectivity and volume.



"AUTOKOIL" All-wave Tuner

Embodies variable reaction coil and five-way selector switch. Covers 200 to 2,000 metres. Engraved Escutcheon 1/- extra.

Price **12/6**

**READ THESE "TEST" REPORTS:**

"AMATEUR WIRELESS" said: "Six miles from Brookmans Park it was possible to separate the two stations."  
"The wave range covered was from below 200 to above 2,000."  
"POPULAR WIRELESS" said: "Gives fine results both in point of Power and Selectivity."

Simplifies Set Construction. Only 5 connections to make in as few minutes. Descriptive Leaflet "PR" and FREE Circuit on request.

BLUE PRINTS for "AUTOKOIL THREE" or "AUTOKOIL REINARTZ THREE" 1/- each. Kits for above, and for ALL "Practical Wireless" sets. Details and Prices on request.

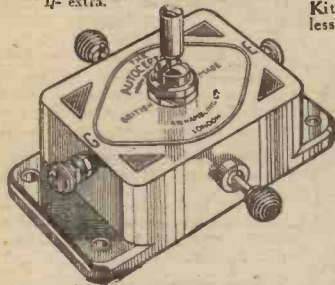

"AUTOCEPTOR" Programme Selector

British Made. Well constructed. Enclosed in dust-proof Green bakelite case. Price **6/-** Post paid

## THE "AUTOCEPTOR"

This wonderful programme Selector gives you at the touch of one switch, either of any two pre-arranged stations and yet does not interfere with normal tuning for any other stations at any time.

"Autoceptors" can be used in any set but method of wiring to circuit varies: full and simple instructions with each one. Only 2 connections to make. Write for Leaflet "AP."

HEADPHONES for "Practical Wireless" "EMPIRE SHORT-WAVE THREE." Sensitive, Light-weight, 4,000 ohms. With cords. Only a few left. PRICE **4/6** Post Paid.

**A. W. HAMBLING, LTD.,** 16, Alfred Place, TOTTENHAM COURT ROAD, LONDON, W.1 Telephone: MUSEUM 7651.

# SHAME!

PRICE 5/- Post Free.

Weight 2 lbs. 4 ozs. Size 13 x 2 x 9.

**GUARANTEED 2 YEARS.**

Special Terms for Sick Children.

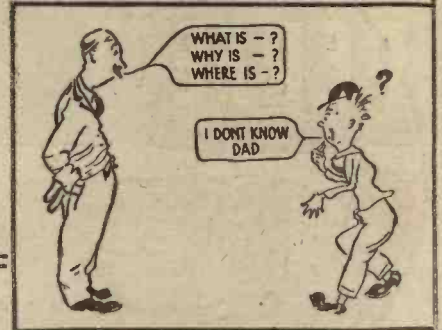

**A WONDERFUL "ELECTRIC" LOOSE LEAF BOOK** (A British Invention) Works from Pocket Lamp Battery.

Oswald gets a shock from the "Brains Department." The truth is, his dad bought him "Something Special" for his birthday, but it looks to us as if he is keeping it for himself.

### INSTRUCTIVE, ENTERTAINING, UNIQUE.

Although the instrument is complete in itself it is possible to specialise in any of the following subjects. WIRELESS, ELECTRICITY, GAMES, GERMAN, FRENCH, DUTCH, GENERAL OBSERVATION, etc. The pages have been arranged by experts and can be obtained in envelopes containing sufficient subject matter to cover 120 questions and answers. Each envelope costing only 6d. plus post.

**THE KINGSLEY ELECTRICAL CO.,** 8, WEST END LANE, LONDON, N.W.6.

## An Essential Book for The Wireless Amateur

THIS book is written for the amateur who desires a fuller knowledge of his subject. It will enable you to attempt research and experiments which before were far beyond your powers. The author has the gift of explaining abstruse subjects in a simple fashion. Fully illustrated.

The **MATHEMATICS of WIRELESS** By **RALPH STRANGER** **5/-**

Obtainable at all Newsagents and Bookstalls, or by post 5/3 from George Neumes, Ltd., 8-11, Southampton Street, Strand, London, W.C.2.

## Another fascinating TIT-BITS TEASER

THE GREAT **16** PUZZLE

When the "16" Puzzle was first introduced it created a tremendous furore throughout the country, and with one accord was acclaimed the most intriguing puzzle the world had ever known. It looked so easy—yet even Cabinet Ministers had to confess themselves baffled! That was 40 years ago, and now the present generation is given the opportunity of "trying its hand" at the Great "16" Puzzle.

Ask for Tit-Bits Teaser, No. 6 **SIXPENCE**

Obtainable at all Newsagents and Bookstalls, or post free 7/3d. from George Neumes, Ltd., 8-11, Southampton Street, Strand, London, W.C.2.

## SATISFIED CUSTOMERS SAY:—

"Your offer for my set was easily the best." "I must congratulate you on your service and speed." "I admire your business methods so much that I am writing to the Editor."

## NO OTHER PART EXCHANGE FIRM CAN OFFER ADVANTAGES LIKE THESE

Prices paid for second-hand apparatus are the **LARGEST PAID BY ANY WIRELESS PART EXCHANGE FIRM.** charge or obligation on DESCRIPTION OF APPARATUS ALONE. **SECOND-HAND APPARATUS TAKEN AS FIRST PAYMENT ON NEW GOODS.** The balance can be spread over six, nine or twelve months. A firm quotation given without any

WHAT WOULD YOU ALLOW ME FOR:—	I AM THINKING OF BUYING:—
ON CASH OR H.P. TERMS Cross out whichever does not apply	
NAME.....	
ADDRESS.....	
Post to-day to:—Co-Radio Ltd., Dept. C 3., 78, Neal Street, W.C.	
<b>THIS PUTS ME UNDER NO OBLIGATION</b>	

# CORADIO

78, Neal St., Shaftesbury Avenue, W.C.

# THE PERFECT PAIR

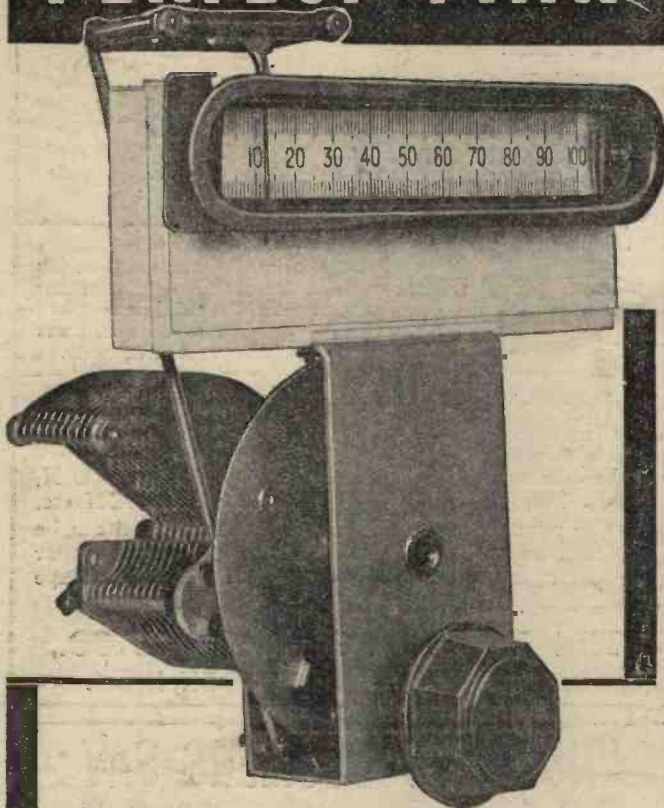

Now, at a price no higher than you would pay for an ordinary condenser you can buy a Utility .0005 condenser complete with the Utility Straight Line Dial.

The Utility condenser is the standby of every discerning expert and amateur and needs no explanation. The Straight Line Dial makes every other type of tuning obsolete. A moving pointer traversing a stationary scale which is always in full view is surely the best method of tuning; but you can only get it with the Utility Dial.

And look at the  
**PRICE**  
**9/6**  
complete as  
illustrated.

From your dealer or post free from the Makers.

**WILKINS & WRIGHT LTD.**  
UTILITY WORKS, HOLYHEAD RD., BIRMINGHAM

London Agents:  
E. R. Morton, Ltd., 22, Bartlett's Buildings, Holborn Circus, E.C.4.

*Utility*

Belmont

# REALISE the IMPORTANCE OF YOUR RESISTANCES PREVENT TROUBLE

## With **ERIE** GRID LEAKS & RESISTORS



Used exclusively by all leading Radio Manufacturers.

And now for the first time available to the amateur. Half the constructor's troubles are due to unstable grid leaks and resistances. Let ERIE carry the load. They are guaranteed in every respect. Safe, silent, stable and impervious to humidity fluctuations, they will solve one of your biggest problems as they have solved the similar problems of the leading Radio Manufacturers.

LOOK FOR **Mr. Ohms**  
The sign of Eric Resistors

All values, one, two, three and five watts, 50 ohms to 4 meg. ohms. Tag identified and Colour Coded. Write for leaflet with Colour Code.

**ERIE RESISTORS** carry an **UNQUALIFIED GUARANTEE** against **BREAKDOWN**

The Radio Resistor Co., 1, Golden Square, Piccadilly Circus, London, W.1

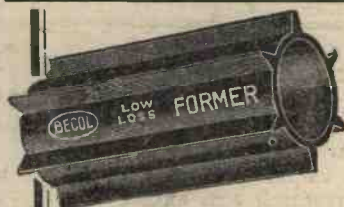

# QUALITY Produces EFFICIENCY

**TESTED BEFORE DESPATCH**  
The original BECOL ebonite low loss formers are thoroughly reliable. They are used in all parts of the world. Look for the BECOL trade mark. Ask your dealer. If unable to supply, write direct. Send now, enclosing 6d. (post free) for up-to-date handbook of tuning coils for DUAL RANGE, BANDPASS, and SUPER-HET. circuits. Fully illustrated with data. A very interesting handbook.

RODS, SHEET, TUBES, PANELS  
**The BRITISH EBONITE Co., Ltd.,**  
Hanwell, London, W.7

## A UNIQUE PERFORMANCE CURVE



is given by this H.F. Choke. Highly finished, non-corrodible moulded case, mechanically strong, and dust and damp proof. Inductance, 128,000 micro-henries; self-capacity, 4.5 micromicrofarads; D.C. resistance, 400 ohms.  
Price **5/6**

Apex H.F. Choke, extremely efficient 1/9

From all dealers or direct,  
**British General Manufacturing Co., Ltd.,** Brockley Works, London, S.E.4.

**BRITISH GENERAL H.F. CHOKE**



Specified for the  
**"EMPIRE SHORT-WAVE THREE"**  
 and for many other PRACTICAL WIRELESS Sets.



**CLIX "MASTER" PLUG.**  
 The Plug with positive METAL to METAL wiring. Widely variable and non-collapsible prongs give firm grip and full contact with ANY battery socket. Specially curved ends for easy insertion. **1d.**  
 Write for interesting Folder 'N.' giving details of over 28 different components for every form of contact.

**CLIX PANEL TERMINAL.**

The TYPE B is an improved and very robust component. It has completely insulated and non-removable head. Note the HEXAGON SHOULDER which allows it to be held with a spanner while the nut behind is made tight. Red or Black with full range of easily read markings. **4d.**

Type A, 2½d.



**CLIX**  
 CHEAPEST PERFECT CONTACT  
 ELECTRO LINX Ltd., 254, Vauxhall Bridge Road, S.W.1.

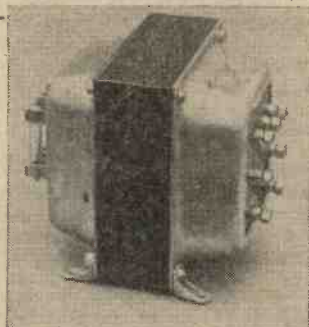

**A MERRY XMAS**  
 to the numerous satisfied users of our Products and all readers.  
**The SUPER SHIELDED 250/60 MAINS TRANSFORMERS**  
 Specified for the  
**"MAINS EXPRESS THREE"**

MAINS TRANSFORMERS AND NOW L.F. TRANSFORMERS which give you just that extra you wanted.  
 CHOKES

Our famous 100 per cent. British Products are repeatedly specified in the leading technical papers and used by the leading experts.

Write now for details and make sure of a Merry Xmas — RIGHT NOW!

Full Terms to the Trade.

**SOUND SALES LTD.**

Please send me illustrated catalogue of all Sound Sales Products. Cut out coupon and trouble, Post to-day.

Mr. \_\_\_\_\_  
 Address \_\_\_\_\_  
 N \_\_\_\_\_  
 Sound Sales Ltd., Tremlett Grove, Highgate, N.19

**Practical Letters from Readers**  
 (Continued from page 620.)  
**Home-made Components**

SIR,—Having taken in most wireless books and papers I naturally started with the first copy of PRACTICAL WIRELESS. Well! I have read all issues from cover to cover and up to the moment PRACTICAL WIRELESS appears to be the one I have been looking for all these years.

Septimus and A. E. Metcalfe I more than agree with and should like to add push-pull transformers, wire-wound resistances, in fact every component that can be made at home. Also in coil-winding data panels please give us the reaction windings or the way to work it out. This is never given unless it is a complete coil; as a rule it is size of former, number of turns for 200 to 600 metres (A.T.I.). R.A. Windings where? Why not a PRACTICAL WIRELESS SG3, with coils, chokes, etc., made at home and a competition for the best-made set and components? Awaiting next week's issue. —J. LEE (South Hackney).

**An Irish Reader's Appreciation**

SIR,—I am a little late in sending my vote of thanks to you for a really practical wireless paper. You are certainly taking and maintaining a step in the right direction. I am the proud possessor of your first nine issues and always look forward to the next one! The clear and up-to-date information written in a non-technical manner cannot fail to satisfy every wireless fan. Every article published was very interesting and instructive. I am on D.C. mains and enjoyed your article on the home construction of smoothing chokes and mains transformers and hope to see more articles on the construction of mains components. The article on the new type of mains valves was equally interesting and I am looking forward to the article on the construction of a three-valve set incorporating them. Wishing your new journal every success. —W. LYNES (Belfast).

**A Few More Suggestions**

SIR,—I take this opportunity to express my appreciation of your new magazine. I have only one "grouse" about it, and that is that you have wasted five or more years before producing it!! There has been a wide field for many years for a magazine of this type, and if it be maintained on its present lines, its popularity will increase. You welcome suggestions, therefore I would like to endorse most heartily the letters recently published asking for data to be given for home constructors. There are many people like myself who can do a great deal with the odd spares, bits and pieces one accumulates, but who simply cannot afford to buy new components every week or so, for any small alterations and improvements they may desire to make. Please give us details of coils, etc., when you publish sets and circuits. If you would give us the details asked for, very many of us can afford a few shillings occasionally for some wire, which one may not have on hand, or a former, or oddments of that kind, with the result that people in the trade would benefit accordingly. Please continue to live up to your name, *Practical WIRELESS*. If people are anxious to know whether the Third Deputy Assistant Announcer's Typist has an oak or mahogany table, they can buy other Weekly Papers, but those thousands who are interested in Radio as a hobby and a business will stick to PRACTICAL WIRELESS as long as you keep it *Practical*. —"KEENLY INTERESTED" (London).

**Watmel**  
**COMPONENTS**  
 GET THE BEST OUT OF ANY SET

When you buy a Watmel component you are certain to obtain a product that is absolutely up-to-date—reliable—flawless and made from only the best British materials. Next time you are in need of a wire-wound resistance try the

**WATMEL SQUARE-LAW TAPERED RESISTANCE**  
 This resistance is specially wound on a tapered former which gives a perfect square law reading. This is the first resistance of its kind.

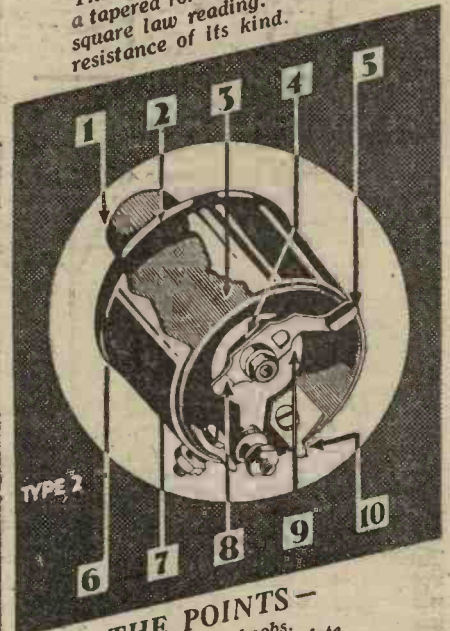

- NOTE THE POINTS —**
1. Polished pointer knobs.
  2. Engraved bakelite front plate.
  3. Wire wound former. N.B. The resistance is WIRE; NOT compound with wire contacts. It is specially wound on a tapered former.
  4. Insulating brush to insulate spindle from panel.
  5. Contact finger. Phosphor Bronze.
  6. One hole fixing — Brass bearing bush resulting in perfect bearing.
  7. Bakelite case — protects winding.
  8. Back self-cleaning contacts.
  9. Large contact plate.
  10. Stops at end of wiring.
- Ask your dealer for full particulars or write direct to us.

SEND FOR OUR CATALOGUE AND FREE CIRCUIT DIAGRAMS.  
**WATMEL WIRELESS CO., LTD.,**  
 Imperial Works, High St., Edgware.  
 Telephone: Edgware 0323. (M.C.63)

# RADIO RAMBLINGS

## Using a Pick-up with A.C. Receivers

A NUMBER of readers are in some difficulty regarding the best method of connecting a gramophone pick-up to R-G SWITCH

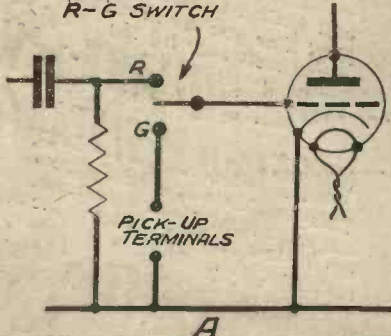

Fig. 1 (A).—The simplest method of joining a pick-up in the detector circuit.

all-A.C. receivers of the same type as our "Mains Express Three." The simplest way is to join one lead to the grid of the detector valve and the other to a convenient H.T. negative lead. Before making the connection, the wire joining the grid condenser to the grid of the valve-holder should be removed. When a pick-up is to be used fairly frequently, it is much better to fit a pair of terminals and a suitable radiogram switch as shown at (A) in Fig. 1. It is important that the switch should be mounted near to the valve-holder in order to avoid long connecting wires. The above method, although very simple, is only satisfactory when the pick-up is of a fairly insensitive pattern. With a sensitive instrument, distortion would occur due to the absence of grid bias on the detector valve (which is now acting as an L.F. amplifier). This latter difficulty can easily be overcome by altering the connections as shown in Fig. 1 (B). A bias resistance and shunt condenser are wired between the cathode terminal of the valve-holder and H.T.—whilst the grid leak is joined directly to the cathode terminal. The result is that the valve becomes negatively biased immediately the switch is turned to the "Gram." position, but the bias is moved on changing over to "Radio." Any resistance of from 300 to 500 ohms will provide a suitable bias voltage for the average type of indirectly-heated detector valve, whilst the by-pass condenser should have a capacity in the region of 1 microfarad.

## Safeguarding the H. T. Battery

WHEN using a reaction condenser of the air dielectric pattern, there is always a danger of the H.T. supply being

## JOTTINGS FROM MY NOTEBOOK. By "DETECTOR."

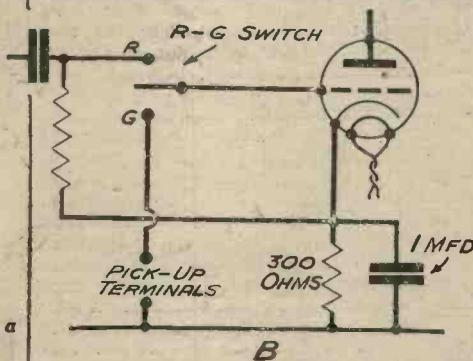

Fig. 1 (B).—How bias is applied to the valve when the pick-up is in circuit.

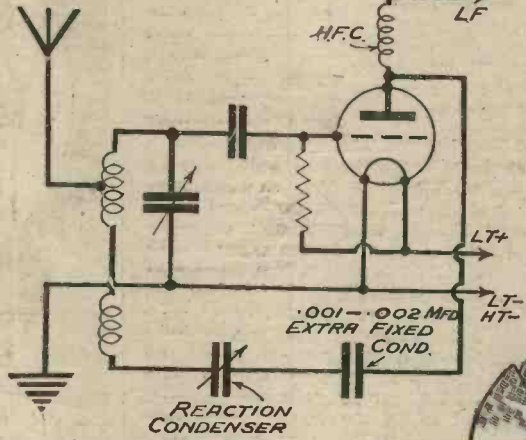

Fig. 2.—How to wire a fixed condenser in series with the reaction condenser to protect the H.T. battery.

short-circuited due to the vanes touching. This is, of course, on account of the fact that one set of vanes is joined to the anode of the detector valve, and the other is connected to earth and high tension negative. A short circuit at this point is indicated when a scratching can be heard as the reaction

condenser is adjusted. As the occurrence of this trouble will quickly ruin the H.T. battery, or cause more serious trouble in a mains set, it is well to guard against it by connecting a mica dielectric fixed condenser in series with the variable one. So long as the new condenser has a fairly large capacity in comparison with the reaction condenser it will not affect the signals at all. In most cases a capacity of from .001 mfd. to .002 mfd. is most convenient. The method of connecting the extra condenser is illustrated in the circuit of Fig. 2.

## Series Condensers

DO you know that the effective capacity of a condenser can be reduced by connecting another one in series with it? This is often useful when building up a short-wave set in which a tuning condenser of, say, .00025 mfd. is required and the only one on hand is a standard .0005 mfd. one. The formula for finding the effective capacity of two series connected condensers is  $C = \frac{1}{\frac{1}{c_1} + \frac{1}{c_2}}$  where  $c_1$  and  $c_2$  are the respective capacities of the two condensers.

For those readers who do not like mathematical formula it might be explained that the above equation shows that, when both condensers are of equal capacity, the resulting capacity is just half that of a single condenser. For example, if two .0005 mfd. condensers are connected in series as shown in Fig. 3 the effective capacity will be .00025 mfd. If each condenser were of .0003 mfd. the resulting capacity would be .00015 mfd.

## Parallel Condensers

WHEN two or more condensers are connected in parallel the effective capacity is equal to the sum of the capacities of individual condensers. For example, if three

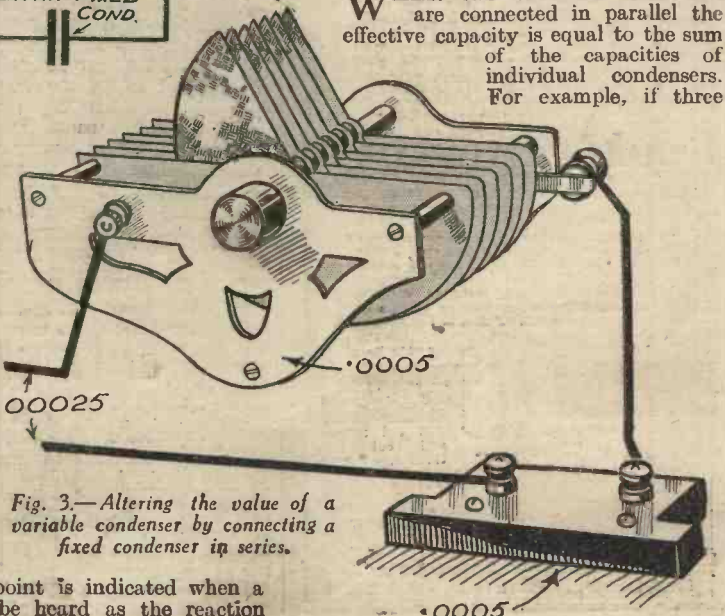

Fig. 3.—Altering the value of a variable condenser by connecting a fixed condenser in series.

condensers of .0001 mfd., .0003 mfd. and .0005 mfd. were connected in parallel, the effective capacity would be .0009 mfd.

**Local-distance Switch**

A NUMBER of commercial receivers are fitted with a "local-distance" switch to prevent overloading when listening to the local station. The action of the switch is in most cases to connect a fixed resistance in parallel with the aerial tuning coil, and the connections are as shown in the circuit of Fig. 4. If you are troubled with overloading by the local just try the idea. Should you wish to have some means of volume regulation the fixed resistance may be replaced by a variable one of 100,000 ohms or so.

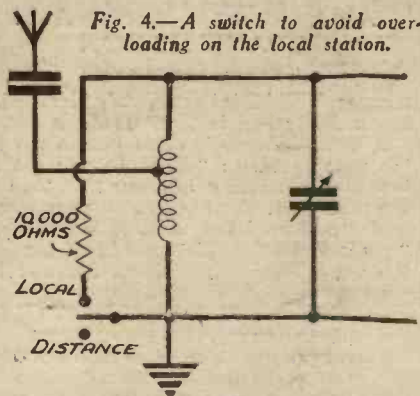

Fig. 4.—A switch to avoid overloading on the local station.

**Tone-control Transformers**

REFERENCE has frequently been made in these columns to the tone control transformers now on the market. No

been experimenting with a view to finding a method of using a transformer of the normal type in a tone-control circuit. I do not propose to give very complete details of my experiments, but merely to present sufficient information to enable you to conduct your own experiments on the same lines and to appreciate the very great advantages of tone control systems. Before going further I would ask you to examine the circuit of Fig. 5 which supplies the basic principles. You will see that an iron cored choke and variable resistance are connected in series across the primary winding of the L.F. transformer, which is wired up in the usual manner. There is an optimum value of inductance for the choke, so in my experiments I used one with a number of

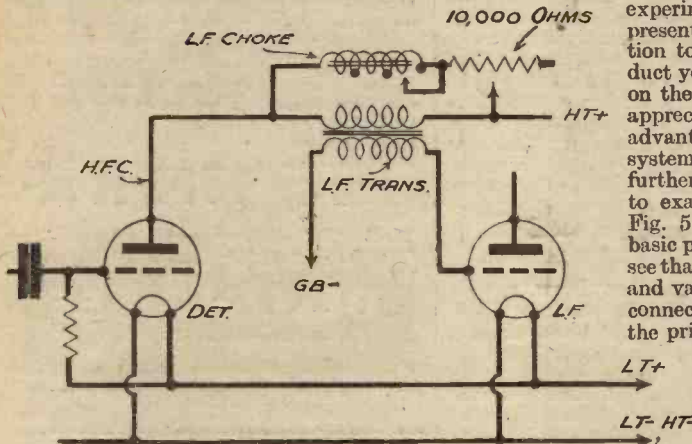

Fig. 5.—A very useful tone-control device consisting of a choke and resistance connected across the transformer primary.

doubt many readers would like to try a transformer of this type but, having one or more ordinary L.F. transformers on hand, do not wish to go to the expense of buying another new one. In an attempt to help people in this latter class I have

number of windings and made as shown in Fig. 6. A core of soft iron wires was tightly pressed into a small cardboard tube on which were fitted four 1-in. diameter cardboard discs. These latter were fixed in position with glue. The bobbin so formed was wound with 4,500 turns of 38 S.W.G. enamelled wire, putting 1,500 in each section. Tappings were taken after winding each section so that three different values of inductance were available. The different tapings were tried in conjunction with various settings of the 10,000 ohm resistance and very interesting results were obtained. It should be stated that the amplification obtained was not so great as with a well-known commercial tone control transformer, but the tests were most instructive and gave conclusive proof of the benefits of tone control.

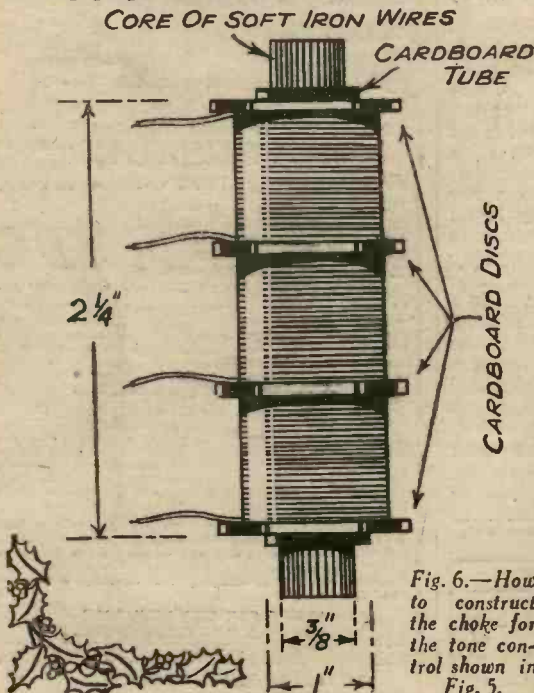
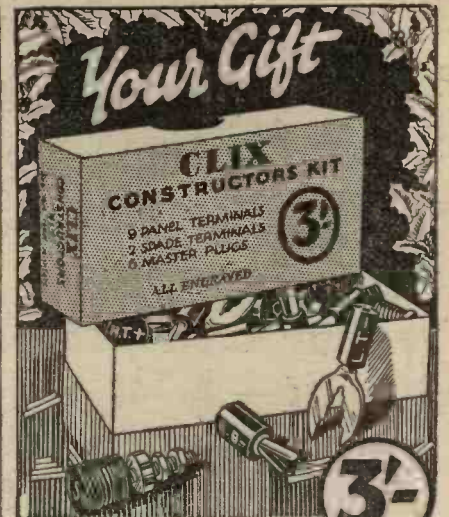

Fig. 6.—How to construct the choke for the tone control shown in Fig. 5.

**Our Free Weekly DATA SHEETS!**

No. 1 will be given with Every Copy of NEXT WEEK'S ISSUE. See special announcement on page 577.



Give yourself or your friend a **CLIX CONSTRUCTOR'S KIT** for Xmas. It contains 9 PANEL TERMINALS, 2 SPADE TERMINALS, 6 "MASTER" PLUGS. Write for all the components necessary to give perfect A., E., H.T., G.B., L.T., and Folder "N" L.S. contacts to any two- or three-valve receiver. Obtainable from all dealers. Free.

**CLIX**  
CHEAPEST PERFECT CONTACT  
LECTRO LINX Ltd., 254, Vauxhall Bridge Rd., S.W.1



Every Thursday **TEST YOUR SET**  
Makes all the difference to Enjoyment and Economy. No skill required with this instrument. "The Wireless World" describes it as "the most comprehensive." The ONLY popular priced instrument testing resistances, as well as voltage of H.T. and L.T. Batteries, valves, transformers, coils, condensers, short circuits, distortion, etc. FOUR readings on one dial (1) 0-150 v. for H.T. (2) 0-6 v. for L.T. (3) 0-30 milliamps (4) resistance test 0-2,000 ohms. Of all Wireless Dealers, Ironmongers, etc., including 4-page instruction leaflet.

**WATES 126 Universal Meter**  
BRITISH MADE BY EMICOL, LONDON  
3 in 1 POCKET METER, L.T. (0-6 v.) H.T. (0-150 v.) and 0-30 milliamps. 8/6  
Pocket case for same, 1/3.  
Explanatory Leaflets post free.  
**WATES RADIO Ltd.**  
184-8, Shaftesbury Avenue, London, W.C.2.



## BUILD your own Mains Unit

If you build your own Mains Unit, you are able to get just the exact output you require. You know your own unit, and can make any adjustments in the future if you alter your receiver. And—it's cheaper! Heayberd Assembled Mains Unit Kits are supplied with the components mounted on the metal base. YOU simply wire-up, following the simple blue-print and instructions provided. Here is a typical example, others are available if this is not suitable.

**HEAYBERD C.150 ASSEMBLED KIT**  
 Alternative Outputs: 25 m.a. at 120v. or 150v.  
 Tappings: 40/110v. Var. S.G., 60/130v. Var.  
 and 150v. fixed. Price **76/-**

Including: Heayberd Transformer, Choke, 16 mf. Condensers, Westinghouse Rectifier, Wire-wound Potentiometers, Resistances and Fuse. Complete in neat metal case—ready for wiring.



## Post Coupon

for Heayberd handbook on Mains Working

I enclose 3d stamps for New Handbook of Mains Equipment. Packed with Technical Tips, Service Hints and diagrams

Mr. \_\_\_\_\_  
 Address \_\_\_\_\_  
 P.R.A.

**F.C. HEAYBERD & Co.,**  
 10 FINSBURY STREET, LONDON, E.C.2  
 One minute from Moorgate Stn

## 10,000 GRAMO-MOTORS FROM STOCK

**BIG CASH DISCOUNT ALLOWED!**  
 Make a Gramophone or Radiogram.  
 Order loose kits or sets and assemble them at home. Get for 3d. our new 64-page Catalogue with scale drawings and instructions how to make them. We sell motors from 7/6, tone-arms, sound boxes, 1/8, pick-ups, big volume horns, loudspeakers, radio kits, complete receiving sets, gramophones, radiograms. Repairs done. Established 1903.



The REGENT FITTINGS Co., D.285, 120, Old Street, London, E.C.1

## INSIST ON PERMCOL

The only non-discolouring Ebonite  
 Specified again this week!  
 From all dealers or direct  
 The British Hard Rubber Co. Ltd., Ponders End

## AMATEUR SHORT-WAVE TRANSMISSION

(Continued from page 619.)

manner, VK2AG is immediately identifiable as an Australian in New South Wales.

A question that is often put to me by the uninitiated is: "How do you get in touch with another amateur?" This is the procedure. You switch on your transmitter and send out what is known as a "general call"; this consists of sending the word TEST three times, followed by your call sign, in this manner:—  
 TEST TEST TEST de G2EE G2EE G2EE the whole being repeated several times and ending with the letter K; this indicates that you wish to test with anyone who hears you. You then listen in on your receiver on the same band of wavelengths as that in which you have been transmitting, and if conditions are suitable will hear some other station replying by sending your call sign several times, followed by his own. When he stops transmitting you reply to him and contact is established. The standard general call for commercial stations, and also for foreign amateurs, is the letters CQ repeated, but this call is forbidden to British amateurs. Another method of making contact is to listen for someone calling either TEST or CQ and to answer that call; there is nearly always someone somewhere doing this!

### International Contacts

The next question that I am usually asked is: "Suppose you work a Finn. How do you manage about understanding one another?" International contacts between people who are unacquainted with one another's language are possible by the extensive use of certain abbreviations, of which there are two kinds, official and unofficial. For the simplifying of radiotelegraphic communication there has been prepared a list of three letter groups beginning with Q that cover almost all the questions and requests ordinarily made in the course of working between commercial stations, and though these are primarily meant for ship to shore work, many of them have been adopted, with slight alterations in meaning, by amateurs the world over. As an example, if I want to ask the Finnish station his address, I merely send the group "QRA?" and am perfectly understood. If he wants me to acknowledge the contact by sending a postcard, he sends "QSL" and I know what he wants. The other set of unofficial abbreviations consists of a large number of English (or American) words and phrases shortened into a few letters, which have become current in all countries. Most of them are obvious to English-speaking people, but presumably to those who do not know our language they are just groups of letters that have a significance in their own tongue, but without any apparent connection with the words they represent. Examples are "pse" for please, "tnx" for thanks, and "73" for best wishes, although this last is in a slightly different class, being a code group in the American morse code used on telegraph circuits in the U.S.; American morse code is not used by amateurs or ship operators and is very different from the Continental code in general use.

**START COLLECTING OUR FREE DATA SHEETS NEXT WEEK!**  
 SEE PAGE 577.

**THE FIRST CHOICE ALWAYS at either Price**

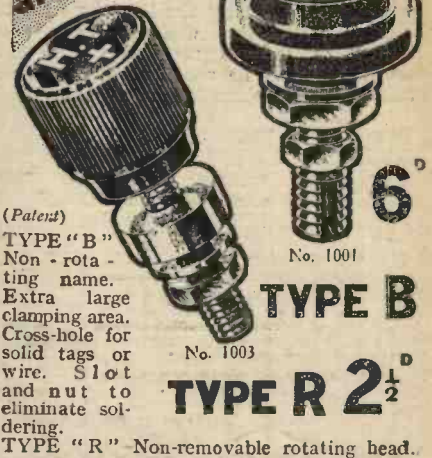

TYPE "B" Non-rotating name. Extra large clamping area. Cross-hole for solid tags or wire. Slot and nut to eliminate soldering.  
 TYPE "R" Non-removable rotating head.

Write for "Radio Connections" post free.  
**BELLING-LEE TERMINALS**  
 Advert of Belling & Lee, Ltd., Cambridge Arterial Road, Enfield, Mdx.

## Emas Bargains



No H.T. Batteries needed with a **SUPERSEDER**

even if you are NOT on the mains.  
 This Brown's device gives you three H.T. voltages D.C. from your filament battery and lasts indefinitely. A boon and a blessing to all H.T. users, and reduced from £3 15s. to **37/6** Only from us.

**VARIABLE CONDENSERS**  
 No. 1, 2-gang "Amro" dual Condensers, new .0005 mfd., a 25/- line at 12/8. Formo de Luxe, new, .0005 mfd. or .00035 mfd., 4/- line boxed.  
 Sale 2/- or 3/9 pair. No. 3. Tebade bakelite Series Aerial Tuning or Reaction Condensers. .0005 mfd., 1/3. Igranite Transformer or Reaction Condensers, 1/8. Preset .001 mfd., 10/4.  
**FIXED CONDENSERS**  
 For Mains Sets, 8 mfd. T.C.C., 450v., electrolytic, as illus., 5/8. Mansbridge 1 mfd., 220v., 10d. 2 mfd., 220v. 1/3. 2 mfd., 440v., T.C.C., 1/8. 10 mfd., 10/8. L.R., 500 mfd., 12v., 10/- .01 mfd., 1.000v., Dubiller, 1/8. 2 mfd., 4,600v., 6/-. Grid Cond., .0002, .0003, .0004, .0005, .0006 and .001, etc., 4d. For others to 50,000v., see List.

**TRANSFORMERS** We are able to offer from stock stampings for chokes and Transformers of 15 sizes and shapes. Write for special booklet, "Design and Construction of Transformers", 1/- Samples of any pair of stampings sent on receipt of envelope with 1/4d. stamp.

**WRITE FOR OUR NEW SALE LIST "P.R." 1,000 BARGAINS. ELECTRADIX RADIOS,**  
 218, UPPER THAMES STREET, E.C.4.

LET OUR TECHNICAL STAFF SOLVE YOUR PROBLEMS

REPLIES TO



If a postal reply is desired, a stamped addressed envelope must be enclosed. Every query and drawing which is sent must bear the name and address of the sender. Send your queries to The Editor, PRACTICAL WIRELESS, Geo. Newnes, Ltd., 8-11, Southampton St., Strand, London, W.C.2.

QUERIES and ENQUIRIES by Our Technical Staff

The coupon on this page must be attached to every query.

SPECIAL NOTE

We wish to draw the reader's attention to the fact that the Queries Service is intended only for the solution of problems or difficulties arising from the construction of receivers described in our pages, from articles appearing in our pages, or on general wireless matters. We regret that we cannot, for obvious reasons—

- (1) Supply circuit diagrams of complete multi-valve receivers.
- (2) Suggest alterations or modifications of receivers described in our contemporaries.
- (3) Suggest alterations or modifications to commercial receivers.
- (4) Answer queries over the telephone.

Please note also, that all sketches and drawings which are sent to us, should bear the name and address of the sender.

INTERFERENCE

"Can you offer a solution to the cracking and roaring which breaks out frequently on my set. It blots out all stations completely, while perfect reception goes on in between."—(H. U., E.17.)

The interference is no doubt due to some external apparatus which is being operated in your locality. Disconnect your aerial and if the noises stop, then the suggestion is correct. To find just what it is which is making the noise you will have to try and make a search of ask neighbours and so find the point of strongest interference. You should soon find out what it is, and the cure rests with the persons operating the machinery or whatever apparatus is the cause of the trouble. If they will not do anything, write to the B.B.C.

MOTOR-BOATING

"I have a straight three set, and instead of oscillating, it makes that terrible noise. I have tried a few methods that I have read about, but can you tell me what to get and what you suggest is the matter?"—(J. K., Ashton-under-Lyne.)

The terrible noise to which you refer may be motor-boating, or on the other hand, it may simply be excessive oscillation, due to the use of too much reaction. If the latter is the case you must use less reaction. You are probably trying to get too great a volume from very weak stations and to do so are forcing the reaction. If the noise is due to L.F. instability, that is, motor-boating, you must decouple the stages as previously pointed out in these pages. Remember to choose the value of the decoupling resistance so that there will not be an undue voltage drop.

REVERSED ACCUMULATOR

"When trying out a new circuit the other night I did not meet with much success, so reverted to my original arrangement. After listening for a little while I suddenly noticed that the accumulator was joined the wrong way round. I immediately switched off, and would like to know whether I have damaged anything. I shall not use the set again until I hear from you."—(R. P. O., Manchester.)

In an ordinary circuit the reversal of the accumulator connection would not do any damage, but would probably simply result in distortion.

THE ALL-POWER ELIMINATOR

"With regard to the eliminator recently described in your pages, I should be glad if you could answer the following points: (1) Would the voltage from a H.T.7 rectifier not be too much for ordinary battery valves, as the maximum plate voltage is generally 150 V.? (2) With regard to the mains transformer, is the primary winding of 36 S.W.G. meant to be copper or resistance wire? 36 S.W.G. copper seems to me rather delicate to withstand 230 V. mains."—(J. S., Edinburgh.)

(1) Provided that the total current consumption of the battery valves is not less than 28 milliamperes the voltage of the eliminator will not be appreciably greater than the maximum rated voltage for the valves

—namely, 150. If the consumption is less than the figure stated a suitable resistance should be inserted between tapping H.T.1 and the set. Alternatively, tapping H.T.2 could be employed to supply the highest voltage.

(2) The wire required for the primary of the mains transformer is 36's gauge enamelled copper wire; this wire will safely carry 180 milliamperes and the maximum current taken by the primary is not much more than 100 milliamperes.

DIAL LIGHT

"I am wanting to fit a small flash-lamp bulb behind my tuning scale in order to simplify the tuning settings and at the same time provide an indication that the set is on. I might add that I am doing this after reading one of your issues stating that it is worth while. I am not sure, however, whether this will run down my accumulator quicker, or whether special lamps are obtainable for the purpose. Are there any other points about this type of light which I should bear in mind?"—(H. G., Highgate.)

The lamp may be a flash-lamp bulb, but special low consumption bulbs are obtainable just as cheaply from any wireless dealer, or direct from Messrs. Bulgin. The voltage will depend upon the voltage of your valves. The leads for the lamp should be taken from the nearest valve-holder, and ordinary twin flex is suitable. The lamp, if you wire from a valve-holder, will only be switched on when the valves are switched on, and will be switched out with the valves.

DATA SHEET No. 12 TABLE OF DIELECTRIC STRENGTHS

Cut this out each week and paste it in a notebook.

Material	Rating
EBONITE .. .. .	30
EMPIRE CLOTH .. .. .	10
FIBRE .. .. .	2
GLASS .. .. .	8
MARBLE .. .. .	2
MICA .. .. .	40
PAPEP, WAXED .. .. .	30
PARAFFIN WAX .. .. .	12
PRESSPAHN .. .. .	5
PORCELAIN .. .. .	10

The above figures give the relative strengths of the materials named, and are an indication of the strength against breakdown. It will be seen from the table that mica is the strongest, and marble the weakest.

FITTING A FUSE

"I have a straight 3-valve set, employing 120 volts, and want to put in a fuse (flash-lamp bulb type), but I am not quite certain where to connect it. Would you please tell me where to fix it?"—(W. F., Rotherham.)

The fuse should be used to join the two battery negative terminals together. If you examine your receiver, you will find that there are two negative terminals, H.T.— and L.T.—. From one of these a lead goes to the filaments, and the two terminals are joined together. The fuse should be inserted in the wire which joins H.T.—, so that the H.T. runs through the fuse to the filaments.

INTERFERENCE

"I have built a three valve S.G. set, and owing to the fact that we have electric light in the house, I am running it off a D.C. eliminator. Of course, there is a two volt accumulator and 18 volt G.B. The eliminator is in perfect condition, yet I get a continuous loud crackling in the speaker; all connections are good. I have tried it on an outdoor and indoor aerial and also a short earth wire to water pipe, and an earth tube.

Having no better results, I decided to try it on a neighbour's aerial and earth. From this I had a perfect reception (this was from an H.T. battery). As I have mentioned before, we are on the mains, and the house has a number of electric wires running through it, whereas in the neighbour's house there was none, as they only have gas. We have the trolley buses running past our house, but I have fixed the aerial in opposition to the wires."—(W. T., No address.)

We think your last paragraph explains your trouble—that is, the trolley buses. If these run very close, the fitting of your aerial at right angles will reduce the interference, but not completely remove it. If it is the buses, then the only cure is the fitting of special apparatus to the buses, and this is, of course, a matter for the corporation. There is, however, the possibility that the interference is due to faulty switches on the house wiring system, and you will be able to find this by operating the switches in turn.

MAINS OUTPUT

"Having taken PRACTICAL WIRELESS from the beginning I must congratulate you on its lucid explanations and its value for money; not being filled with advertisements and no reading matter, as in most journals. I wish to take advantage of your service for answering problems and I should be greatly obliged for information as I am curious on several points.

I have an all mains commercial receiver which incorporates a rectifying valve. The type recommended by the makers gives an output of 60 milliamperes rectified current. I have also used a valve giving an output of 30 milliamperes and notice very little difference. Is it possible that this valve does not impose so much wear on my other valves and is it practical for me to use a rectifying valve giving 75 or 100 milliamperes and make my set more efficient and to give more volume? Also, the valves I use are full-wave. What is the meaning of this and the difference between it and half-wave?"—(S. L., Coventry.)

Use of a 30 m/a rectifying valve will not save your valves or prolong their life in any way. On the other hand, the use of a 75 m/a or 100 m/a rectifier will not improve the performance of your receiver. The valves take just what they want in the way of current, no more and no less. If there is not sufficient voltage available, the voltage is automatically dropped; this is what happens, no doubt, when the 30 m/a rectifier is used, resulting in slightly decreased volume. The 60 m/a rectifier supplies ample for the requirements of your set. You will not get any higher voltage by using a rectifying valve with a larger output still, because such is beyond the limits of your mains apparatus.

It will be your rectifying valve that is a full-wave, not the valves in your receiver. The meaning of full-wave rectification is that both positive and negative half-waves of A.C. current are rectified. The valve has two anodes, or plates, one connected to each end of a transformer winding; the negative connection is taken from a centre tapping of this winding. Now, every time one end of the secondary winding is negative, the other is positive, consequently there is always a flow of current from the filament to one of the anodes. The centre tapping, having a potential half-way between the two ends of the winding, is always negative in respect to the positive end.

DIAL LIGHT FROM A.C.

"I propose fixing a Dial Light behind condensers in an A.C. Super-Het and would light from valve heater terminals if that is in order. If so, must I use twin metallised flex and must I earth to copper foil on baseboard?"—(R. McF., Glasgow.)

It will be quite in order to work your pilot light from the valve heater terminals, but we would strongly advise you to run twin leads straight from these terminals to the pilot light, and not to try earthing the arrangement in any way. The leads should be twisted to avoid any possibility of mains hum; ordinary house lighting twin-flex will serve the purpose admirably.

FREE ADVICE BUREAU COUPON

This coupon is available until Dec. 17th, 1932, and must be attached to all letters containing queries.

PRACTICAL WIRELESS, 10/12/32.

# CATALOGUES RECEIVED

To save readers trouble, we undertake to send on catalogues of any of our advertisers. Merely state, on a postcard, the names of the firms from whom you require catalogues, and address it to "Catalogues," PRACTICAL WIRELESS, Geo. Newnes, Ltd., 8/11, Southampton St., Strand, London, W.C.2. Where advertisers make a charge, or require postage, this should be enclosed.

## BRITISH GENERAL COMPONENTS

A COMPREHENSIVE range of these high-class components is given in the latest list issued by British General Manufacturing Co., Ltd. The new B.G. band-pass filter coils comprise a range of three types. The first is a band-pass aerial coil, the second a band-pass H.F. coil, and the third a screened H.F. coil designed to match with either of the other two. Another new component listed is a dual-wave coil covering a range of 200 to 2,000 metres. These coils are screened, and are highly efficient, compact and well designed components. Among the other components shown in the list are a new condenser ganging device, output and L.F. transformers, and H.F. chokes. Particulars are also given of various full-size wiring layouts. The address is Brockley Works, Tyrwhitt Road, London, S.E.4.

## PIX VALVES

A NEW folder we have just received gives particulars of Pix valves, together with their characteristics and curves. These valves, which are remarkably low in price, have a triple-coated Neodymium filament which produces a strong controllable emission. Printed on the folder is a useful comparison table of Pix valves, with various other makes. A copy of the folder can be obtained from British Pix Co., Ltd., 118, Southwark Street, London, S.E.1, enclosing a stamp for postage.

## SOLE ELECTRIC SOLDERING IRON

MUCH of the trouble experienced by the home constructor when soldering wiring connections can be eliminated by the use of a good make of electric soldering iron. The Solon Electric Soldering Iron is particularly useful for radio work, as the heat is maintained continuously—no cooling-off in the middle of a job. This enables neat and uniform joints to be made in a simple, straightforward way, especially if Henley Resin Cored Solder is used in place of ordinary soft solder and a separate flux. These electric irons, which are priced at 7s. 6d., are made for various voltages, ranging from 100 to 250, and are provided with 6 ft. of twin circular flex and standard lampholder-adaptor. Further particulars are given in a booklet and also in a neat folder we have received from W. T.

Henley's Telegraph Works Co., Ltd., Holborn Viaduct London, E.C.1.

## Broadcast Query Corner

UNDER the above title, with the assistance of a recognized authority on foreign broadcasting matters and a regular contributor to wireless publications both at home and abroad, we are inaugurating a special Identification Service, which should prove of great assistance to our readers. When tuning in well-known stations it happens frequently that listeners pick up wireless transmissions of which they fail to recognize the origin. It is to solve these little problems that the Broadcast Query Service has been organized.

In order that a careful search may be made it is essential that certain data should be supplied to the best of the inquirer's ability and knowledge. When sending such queries to the Editor the following rules should be followed:—

1. Write legibly, in ink. Give your full name and address.
2. State type of receiver used, and whether transmission was heard on headphones or on loud-speaker.
3. State approximate wavelength or frequency to which receiver was tuned, or, alternatively, state between which two stations (of which you have the condenser readings) the transmission was picked up.
4. Give date and time when broadcast was heard. Do not forget to add whether a.m. or p.m.
5. Give details of programme received, and, if you can, some indication regarding the language, if heard.
6. State whether and what call was given and/or kind of interval signal (metronome, musical box, bells, etc.) between items.
7. To facilitate publication of replies, append a *nom-de-plume* to your inquiry.

Although the service is mainly applicable to broadcasting stations, wherever possible replies will be given in regard to morse transmitters (commercial stations, fog beacons, etc.) and short-wave broadcasts. For the identification, however, of stations operating on channels below 100 metres it will be evident to inquirers that a closer estimate of wavelength must be submitted than in the case of broadcasts on the medium or long waveband if successful identification is to be carried out.

All inquiries should be addressed to *The Editor, PRACTICAL WIRELESS, 8-11, Southampton Street, Strand, London, W.C.2,* and the envelope marked *Broadcast Query Service,* in top left-hand corner. Stamped addressed envelope should not be enclosed, as replies cannot be sent by post, but will be published in due course in each issue of PRACTICAL WIRELESS.

## Replies to Broadcast Queries

MAJESTY (Preston): Please number your queries. (1) Sundsvall relaying Stockholm, Sacred Service; (2) Bratislava relay of "radio film" from Moravská Ostrava; (3) Augsburg-Kaiserslautern on common wave relaying Munich. FOURD IP (Broadstairs): Scheveningen Haven (Holland) on 1,071 m. Commercial Transmitter only; broadcasts Stock Exchange quotations; no wireless entertainment. EARLY BRD (Parkhead): Some indication of wavelength should be given. If on "long" waves at that time either Leningrad or Moscow. ENTHUSIAST (Peterborough): Reykjavik, Iceland. D. X. FAN (Blackburn): (1) PTA, Ste. Assise (Paris) on 25.12 m.; (2) Possibly DGN, Nauen (Germany), on 31.08 m.; (3) Regret, cannot trace. ONE VALVE (Milverton): Nürnberg; Munich interval signal. LEAKY OUID (Norwich): Wavelength wrong; apparently KDKA, East Pittsburgh, on 300 m.; relay of Sacred Service from Shadyside Presbyterian Church.

Famous Maker's Offer! **£5 Radio-Gram CABINET for 65/-**  
SEVEN DAYS' FREE TRIAL  
(OR 10/- MONTHLY)  
Polished Oak and Piano built! The acoustic tone brings a fine thrill. Makers to Radio-Press L.B.C. 3,000 ditentele.  
Other Models 35/- to £15. Photographs and List FREE.  
**PICKETTS** Piano-Tone Cabinets.  
(P.R.) Albion B.I., Bexleyheath

## ENGINEERS

### SIT DOWN AND THINK THIS OVER

Can you allow any opportunity for a first-class job to pass by unheeded? "ENGINEERING OPPORTUNITIES" points the sure way to many such opportunities. You cannot afford to miss this book. It gives details of all recognised Examinations (A.M.Inst. C.E., A.M.I.Mech.E., I.E.E., S.P.O., etc.), outlines Modern Home-study Courses in all branches of Civil, Mech., Elec., Motor, Radio, Aero and "Talkie" Engineering, and explains the unique advantages of our Employment Dept. The book is FREE. Send a postcard for your copy NOW.

**BRITISH INSTITUTE OF ENGINEERING TECHNOLOGY.**  
390, Shakespeare House, 29/31, Oxford Street London, W.1.

## OSTAR-GANZ

### HIGH VOLTAGE MAINS VALVES

Incorporating the most recent development in valve design—full mains voltage indirectly heated filament. These valves work direct off either A.C. or D.C. supply. No mains transformers or breakdown resistances required. Considerably lower current consumption than any other mains valves. Remarkably free from mains hum. A520 (G.P.), W510 (E.C.), U520 (L.F.), 1716, L1925 (Power) B1-; Rectifying Valves: EG50 ma., 12/6. EG100, 12s. m.a., 18/6.

Descriptive leaflet on request.

EUGEN FORBAT (Sole Representative for Great Britain), c/o Nivalight Ltd., 1, Rosebery Av., London, E.C.1. Tel.: Clerkenwell 1829.

## UNIVERSAL RECEIVER AND AMPLIFIER KITS

With British components. All instructions. Complete ready for assembly. Highly efficient yet cheap because of the Ostar Universal High Voltage Valves. Work off either A.C. or D.C.

- 2-Valve Receiver with Rectifier 26.10.0
- 2-Valve Amplifier with Rectifier 24.4.0
- 3-Valve Receiver with Rectifier 29.9.0
- 3-Valve Amplifier with Rectifier 25.5.0
- Mains Energized Loud Speaker Kit with Ostar-Ganz Valves ... £2.5.0

## ADVERTISEMENT INDEX

Barrett, C. S. ... ..	Page 610	Lanchester's Laboratories, Ltd. ... ..	Page 609
Belling & Lee, Ltd. ... ..	626	Lectro Linx, Ltd. ... ..	623 and 625
Bennett College Ltd. ... ..	617	Lissen Ltd. ... ..	592
British Ebonite Co. Ltd. ... ..	622	London Electric Wire Co. and Smiths Ltd. <i>Inside Front Cover</i>	
British General Mfg. Co., Ltd. ... ..	622	Mayfair Radio, ... ..	610
British Hard Rubber Co., Ltd. ... ..	626	Newnes' Books ... ..	<i>Inside Back Cover and 621</i>
British Institute of Eng. Technology ... ..	628	Ostar-Ganz (Eugen Forbat) ... ..	628
British Pix Co., Ltd. ... ..	609	Peto-Scott Ltd. ... ..	575
Block Batteries, Ltd. ... ..	590	Picketts ... ..	628
Bulgin, A. F., Ltd. ... ..	576	Pioneer Radio Mfg. Co., Ltd. ... ..	610
Celestion, Ltd. ... ..	613	Radio Resistor Co. ... ..	622
Co-Radio, Ltd. ... ..	621	Radio Technical Agency ... ..	610
Cossor, A. C. Ltd. ... ..	585	Reacto Appliances, Ltd. ... ..	610
Dubilier Condenser Co., Ltd. ... ..	619	Regent Fittings, Co. ... ..	626
Edison Swan Electric Co. Ltd. ... ..	<i>Back Cover and 573</i>	Reproducers and Amplifiers, Ltd. ... ..	574
Electradix Radios ... ..	626	Slektun Products, Ltd. ... ..	610
Graham Farish Ltd. ... ..	<i>Front Strip and 586</i>	Sound Sales, Ltd. ... ..	623
Hambling, A. W., Ltd. ... ..	621	Telegraph Condenser Co., Ltd. ... ..	613
Hand, P. W. & Co. ... ..	610	Telsen Electric Co., Ltd. ... ..	589
Harlie, Ltd. ... ..	574	Watmel Wireless Co., Ltd. ... ..	623
Hayberd, F. C., and Co. ... ..	626	Wates Radio Ltd. ... ..	625
Impex Electrical, Ltd. ... ..	617	Wilkins & Wright Ltd. ... ..	622
Kingsley Electrical Co. ... ..	621	Wingrove and Rogers, Ltd. ... ..	609
Kniveton Cable Works, Ltd. ... ..	610		

# Christmas Gift Books

## GEORGE NEWNES, LTD.

### WIRELESS BOOKS

**THE OUTLINE OF WIRELESS** 8/6  
By RALPH STRANGER (Omnibus size) Post free 9/-

A comprehensive work on wireless that everybody can understand. Specially written for the "man in the street," it covers the whole subject of wireless reception from A to Z. *Third Edition.*

**THE MATHEMATICS OF WIRELESS** 5/-  
By RALPH STRANGER Post free 5/3

This book is essential for the wireless amateur who desires to gain a fuller knowledge of his subject. Written by one who has the gift of explaining abstruse subjects in a simple fashion. 256 pages, fully illustrated.

**WIRELESS, THE MODERN MAGIC CARPET** 3/6  
By RALPH STRANGER. (*Fourth Edition.*) Post free 3/9

Wireless simply explained at the beginning and seriously treated at the end.

**FINDING FOREIGN STATIONS** 3/6  
By R. W. HALLOWS. (Long Distance Wireless Secrets.)  
Post free 3/9

A book which will be eagerly welcomed by all wireless enthusiasts. It will solve their difficulties and enable them to obtain the best possible results of which their sets are capable.

**WIRELESS STEP BY STEP** 2/6  
By "DICTRON." (*Ninth Edition.*) Post free 2/9

A book which shows the wireless enthusiast how to obtain the maximum enjoyment from his wireless set.

**RADIO PLAYS** 2/6  
By L. DU GARDE PEACH. Post free 2/9

Millions of wireless listeners who have been thrilled by such plays as "The Path of Glory" and "The Mary Celeste" will now be able to read them in book form. Mr. du Garde Peach has written some of the most successful plays ever broadcast.

**The "WILLIAM" BOOKS** 2/6 each  
By Richmal Crompton Post free 2/9

For reading, anywhere, anytime, by anyone.  
Each volume contains a collection of "William's" side-splitting adventures.

WILLIAM—THE PIRATE  
WILLIAM'S CROWDED HOURS  
WILLIAM'S HAPPY DAYS  
WILLIAM THE BAD  
WILLIAM  
WILLIAM THE GOOD  
WILLIAM—THE OUTLAW  
WILLIAM—IN TROUBLE  
WILLIAM—THE CONQUEROR  
STILL WILLIAM  
WILLIAM—THE FOURTH  
WILLIAM AGAIN  
MORE WILLIAM  
JUST WILLIAM

### CHILDREN'S ANNUALS 1933

**THE CIRCUS & FUN FAIR ANNUAL** 2/6  
NEW THIS YEAR. Post free 2/9

All old friends are here in picture and story—the Ring-master, the Trick-rider, the Clowns, and a host of funny men and animals.

**PUNCH AND JUDY CHILDREN'S ANNUAL** 2/6  
Post free 2/9

Crammed from cover to cover with the adventures of Punch and Judy, to say nothing of the famous dog, Toby.

**TIM, TOOTS and TEENY ANNUAL** 2/6  
Post free 2/9

Tim the cat, Toots the pig, and Teeny the duck are a queerly assorted trio and their comic antics are a joy.

**HOBBIES' NEW ANNUAL** 3/6  
Post free 3/9

Contains practical descriptions of working models of every type. Fully illustrated and gives loose insets of parts for making workable models.

*Picture covers beautifully printed in colour. 128 pages. Profusely illustrated. Crown quarto. Quarter bound. Cloth spine.*

**"OMNIBUS BOOKS"** 8/6 each  
Post free 9/3

**THE OUTLINE OF ART**  
Edited by Sir WILLIAM ORPEN, K.B.E., R.A., R.I.

A clear and concise view of the work of the great masters, and the essentials of present-day art; 300 reproductions.

**THE OUTLINE OF LITERATURE**  
By JOHN DRINKWATER.

The history of literature from the earliest books to the work of the twentieth century writers. 80 pages of admirable reproductions.

**THE OUTLINE OF NATURAL HISTORY**  
By Professor Sir J. ARTHUR THOMSON, M.A., LL.D.

This comprehensive work is a mine of information and a reliable guide to the study of Living Creatures. Fully illustrated.

### MISCELLANEOUS

**THE BOOKLOVER'S DIARY**

Leather 2/6; Cloth 1/-  
Post free 2d. extra.

Published by *John o' London's Weekly*, in conjunction with Charles Letts & Co.

This delightful diary contains a wealth of information which will fascinate everyone whether interested in literature or not.

GEORGE NEWNES, LTD., 8-11, SOUTHAMPTON ST., STRAND, LONDON, W.C.2.

# "RADIO AS IT SHOULD BE"

means a good set and

an

## R.K.

Now that R.K.'s are available at such low prices, there is no longer any need to put up with second-rate reproduction. In the R.K. range of speakers at prices from £2.17.6 there are models to suit all purses and purposes. Each is designed to give in its particular sphere of operation, the characteristic R.K. balanced reproduction and fine sensitivity. All good radio dealers will be glad to demonstrate R.K.'s. A range of output transformers, specially designed for use with R.K.'s, is available.



**Senior A.C. Unit  
for  
mains operation  
Price - £7-15-0**



Minor R.K. Permanent Magnet Model

Prices:—

Fumed Oak "ARUNDEL" model £2.17.6

Walnut "ARUNDEL" model £3.3.0

Senior R.K. Permanent Magnet Model

Prices:—

"WARWICK" model in Oak £8.10.0

"WARWICK" model in Walnut £8.17.6

Senior R.K. Permanent Magnet Model

Price:—

"WINDSOR" model in Oak £8.10.0

The above mentioned speakers are supplied complete with multi-ratio transformer.



Specified by the B.B.C. for Broadcasting House.

**B.T.H.**

**MOVING COIL  
EDISWAN RADIO**



**REPRODUCERS  
100% BRITISH  
MODELS**

1933

The Edison Swan Electric Co. Ltd.



155 Charing Cross Rd. London. W.C.2

W.193



**FREE INSIDE! No. 1 OF OUR DATA SHEETS**

# Practical Wireless

**3<sup>D</sup>**

Published every Wednesday by  
**GEORGE  
NEWNES  
LTD.**

Vol. 1—No. 13  
DECEMBER 17th, 1932  
Registered at the G.P.O. as a Newspaper.

## *The* **MIDGET 2**

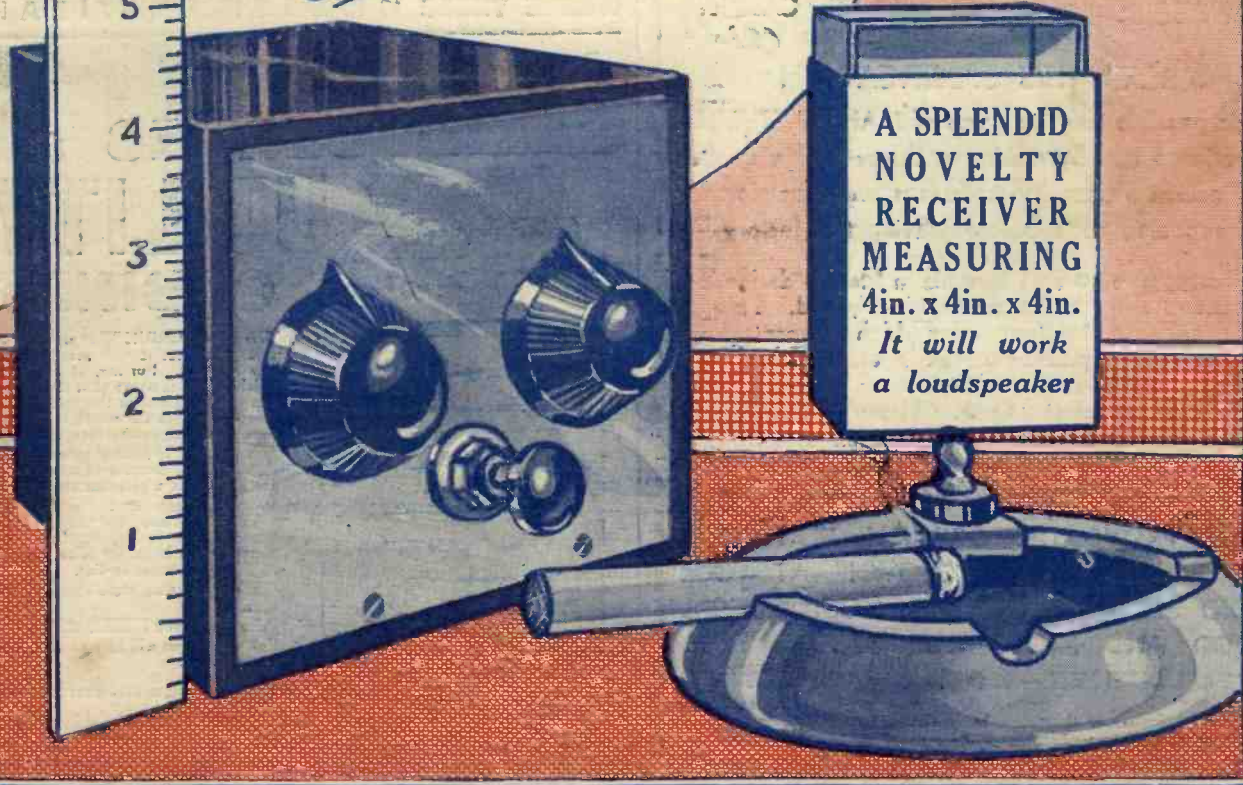

**A SPLENDID  
NOVELTY  
RECEIVER  
MEASURING  
4in. x 4in. x 4in.  
It will work  
a loudspeaker**

Build your "Practical Wireless" Set with a

# PILOT AUTHOR KIT

*It's Exact to Specification*

**THE MORE CRITICAL YOU ARE  
THE MORE CERTAIN YOU ARE  
TO CHOOSE THE  
"RENOWN"**

THE  
SPEAKER  
WITH  
THE  
PERFECT  
ACCENT



YOU CAN  
BUY IT FOR  
**27'6**  
(CHASSIS)

ALSO  
COMPLETE  
IN REAL  
WALNUT  
CABINET  
**42'-**

READ THIS SPECIFICATION

made possible only by years of MANUFACTURING experience and by making at the rate of a quarter of a million a year, by meticulous precision methods and repeated tests before leaving the factory.

Incorporating a new formula in Magnet design, concentrating the flux where it is required. This is achieved by employing high percentage Cobalt Pole pieces—the body of the Magnet being made from special metal. Specially treated "Veratone" Cone. Heavy gauge steel chassis. Overall diameter 8½". Complete with Multi-ratio Transformer for use with any output Valve. Highly finished glossy brown cellulose.

NOW PROVE THE OPINION YOU HAVE FORMED: HEAR THE "RENOWN" AT YOUR RADIO SHOP. BE IN YOUR MOST CRITICAL MOOD AND PROVE OUR WORDS TRUE.

**FULL SIZE—NOT A MIDGET.**

Full particulars of this and other proved models (including the famous "Dreadnought" at 39/6) sent post free on request.

**GOODMANS**

69, ST. JOHN STREET, LONDON, E.C.1.  
Clerkenwell 3838-9.

**LISTEN**  
WITH A  
**P/X**



CUT OUT POWERFUL  
AND LOCAL STATIONS  
AND BRING IN THOSE  
ELUSIVE FOREIGNERS



**FIX A P/X  
IN YOUR AERIAL**

Just undo the aerial wire from the aerial terminal on your set and fix it to one end of the PIX and join the other end with a small piece of wire to your aerial terminal. Close the PIX up, tune in the powerful or local station you are trying to cut out, as loud as possible, then open the PIX until this station disappears (a ½ in. is generally sufficient), then re-tune your set, bringing in those stations on either side which hitherto were being "swamped."

A PIX IMPROVES EVERY SET—and is better than a preset aerial condenser because it has a minimum capacity of .000004 (certified by Faraday House) lower than any form of condenser. It also has a greater range (40-1 maximum to minimum) and is out of action when closed. Fix a PIX in your aerial to-day and cut out local and powerful stations and enjoy foreign concerts.



**"IT IS A LITTLE MARVEL!"  
READ WHAT THIS USER SAYS**

"I thought you would be pleased to hear I have found the PIX most satisfactory. In fact it is a little marvel. My friends were astounded. The reception is much clearer and it is quite simple to cut out Stations that would otherwise swamp each other."—R.W.S., Croydon.

THE BRITISH PIX COMPANY, LTD.,  
(Dept. 303), 118/28, Southwark Street, LONDON, S.E.1  
Telephone: HOP 1001/2

WITH CLIP, 2/9.  
**WHERE THERE IS RADIO THERE MUST BE A PIX**

**A good set  
DESERVES a  
UTILITY  
CABINET**

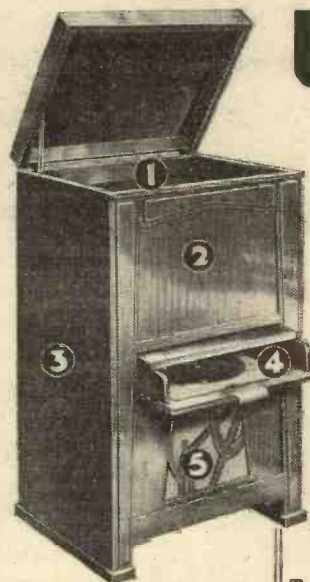

This unique CABINET is so designed and built that it will accommodate any size set. Further, it has been finished in such a way that should you not desire to utilise the gramophone compartment at the outset, it still presents outwardly a complete appearance. It is very solidly built of seasoned Oak (Walnut or Mahogany at slight extra cost), and has a pleasing appearance. Its dimensions are: Height, 3ft.; Width, 1ft. 9ins.; Depth, 1ft. 6ins. Panel space is 15½ins. by 10ins. Baseboard is 18ins. by 15ins. Depth of Turntable space is 4ins.

When ordering state size of Baffle opening.  
Price (delivered FREE), £3 10s.  
Full particulars will be sent on receipt of COUPON.

1. Gramophone section with automatic hinged lid.
2. Fret opening, size 15½ins. by 10ins.
3. Ample depth—18ins.
4. Sliding drawer for Records, with flap lid.
5. Speaker Fret of pleasing design.

**POST THIS COUPON**

To WOODWARE SUPPLIES, LTD.,  
Meeting Street, WEDNESBURY.

Name.....

Address.....

P.W. 1,32.

# PETO-SCOTT RADIO BY MAIL

## ORDER YOUR XMAS RADIO NOW!

**TELSEN JUPITER S.G.3.** Complete kit as advertised, less valves and Cabinet. Cash Price £3/17/0. Carriage Paid. Balance in 11 monthly payments of 7/-.

Send 7/- only.

**EPOCH "20 C" PERMANENT MAGNET MOVING-COIL SPEAKER.** (New Edition). With 5-ratio input transformer. Cash Price £1/15/0. Carriage Paid. Balance in 5 monthly payments of 6/6.

Send 6/6 only

**BLUE SPOT SPEAKER UNIT AND CHASSIS.** Type 100 U. Cash Price £1/12/6. Carriage Paid. Balance in 6 monthly payments of 5/2.

Send 5/2 only

**ROLA PERMANENT MAGNET MOVING-COIL SPEAKER F.6.** With universal tapped input transformer. Cash Price £2/9/6. Carriage Paid. Balance in 11 monthly payments of 4/6.

Send 4/6 only

**R & A "VICTOR" PERMANENT MAGNET MOVING-COIL SPEAKER DE LUXE.** With 6-ratio input transformer and protecting grille. Cash Price £3/10/0. Carriage Paid. Balance in 11 monthly payments of 6/5.

Send 6/5 only

**R & A "CHALLENGER" PERMANENT MAGNET MOVING-COIL SPEAKER.** With special Ferranti multi-ratio input transformer. Cash Price, Carriage Paid, £1/15/0. Balance in 5 monthly payments of 6/6.

Send 6/6 only

**W.B. PERMANENT MAGNET MOVING-COIL SPEAKER P.M.2.** With 3-ratio input transformer. Cash Price £4/5/0. Carriage Paid. Balance in 11 monthly payments of 7/10.

Send 7/10 only

**CELESTION P.P.M. PERMANENT MAGNET MOVING-COIL SPEAKER** with impregnated diaphragm and dual-impedance input transformer. Cash Price, Carriage Paid, £2/7/6. Balance in 11 monthly payments of 4/6.

Send 4/6 only

**SONOCHORDE PERMANENT MAGNET MOVING-COIL SPEAKER,** with universal input transformer. Cash Price, £1/12/6. Balance in 5 monthly payments of 6/-.

Send 6/- only

**BLUE SPOT 66R UNIT AND MAJOR CHASSIS.** Cash or C.O.D. £2/10/0. Carriage Paid. Balance in 11 monthly payments of 4/7.

Send 4/7 only

**EKCO H.T. ELIMINATOR A.C.25** for A.C. mains. Tapped S.G. variable, 50/80 volts and 120/150 volts max. at 25 m/A. Cash or C.O.D. Carriage Paid, £3/17/6. Balance in 11 monthly payments of 7/-.

Send 7/- only

### SOLO KNOB 3

as described in last week's issue.

### KIT "A" CASH or C.O.D. Carriage Paid.

Author's Kit of specified parts, including ready drilled panel, but less valves and cabinet.

# £3-0-0

or 12 monthly payments of 5/6.

#### KIT "B"

As Kit "A" but with valves, less cabinet, CASH or C.O.D. Carriage Paid.

# £4-2-9

or 12 monthly payments of 7/6.

#### KIT "C"

As Kit "A" but with valves and cabinet, CASH or C.O.D. Carriage Paid.

# £4-17-9

or 12 monthly payments of 9/-.

3 Specified Valves £1-2-9. Cabinet 15/-

**READY RADIO "METEOR" S.G.3.** Three-valve screened-grid receiver, with valves, cabinet and permanent-magnet moving-coil speaker. Covers short, medium and long waves without coil changing. Cash Price, £8/17/6. Carriage Paid. Balance in 11 monthly payments of 16/3.

Send 16/3 only

**READY RADIO "METEOR" S.G.3.** Three-valve screened grid receiver. Covers short, medium and long waves without coil changing. Cash Price (less valves and cabinet), £3/15/3. Carriage Paid. Balance in 11 monthly payments of 7/-.

Send 7/- only

**W.B. PERMANENT MAGNET MOVING-COIL SPEAKER, Type PM4.** Complete with transformer. Cash Price £2/2/0. Carriage Paid. Balance in 7 monthly payments of 5/9.

Send 5/9 only

**BLUE SPOT UNIT AND CHASSIS, Type 99 P.M.** Including matched transformer. Cash Price £2/19/6. Balance in 11 monthly payments of 5/6 only

Send 5/6 only

## THIS YEAR'S WINNER LISSEN "SKYSCRAPER"

### COMPLETE WITH VALVES S.G.3

#### CHASSIS KIT

with (Lissen) S.G., Detector and Pentode Valves. Cash Price, Carriage Paid, £4/9/6. Delivered, carriage paid, on first payment of Balance in 11 monthly payments of 8/3.

# 8/3

#### CABINET KIT

with (Lissen) Valves, Walnut Cabinet and special Balanced Armature Loud-speaker. Cash Price, Carriage Paid, £6/5/0. Delivered, carriage paid, on first payment of Balance in 11 monthly payments of 11/6.

# 11/6

## ONLY FROM PETO-SCOTT ON GENEROUS EASY TERMS Carriage paid to your door

**ATLAS ELIMINATOR, Type A.C.244.** Three tappings. S.G., Detector and Power. Output: 120 volts at 20 m/A. Cash Price £2/19/6. Carriage Paid. Balance in 11 monthly payments of 5/6.

Send 5/6 only

**HEAYBERD H.T. UNIT D.150.** Tapped variable 60/120 v., variable 0/150 fixed. Max., 25 m/A at 150 v., 20 m/A at 120 v. Cash Price, Carriage Paid, £4/6/0. Balance in 11 monthly payments of 8/10.

Send 8/10 only

**EKCO A.C.18 H.T. ELIMINATOR** for A.C. mains. Tapped S.G. 80 v. 120/150 v. at 12 m/A. Cash Price, Carriage Paid, £3/7/6. Balance in 11 monthly payments of 6/3.

Send 6/3 only

**GARRARD INDUCTION GRAMOPHONE MOTOR.** For A.C. mains. Model 202. Mounted on 12-inch nickel motor plate with fully automatic electric starting and stopping switch. Cash Price £2/10/0. Carriage Paid. Balance in 11 monthly payments of 4/7.

Send 4/7 only

**EPOCH "A2" PERMANENT MAGNET MOVING-COIL SPEAKER.** Cash or C.O.D. Carriage Paid £3/3/0. Balance in 11 monthly payments of 5/9.

Send 5/9 only

**REGENTONE W.I.F. H.T. ELIMINATOR** for A.C. mains. Tapped for S.G., Detector and Power. 120/150 volts max. at 12 m/A. Cash or C.O.D., Carriage Paid, £2/15/0. Balance in 11 monthly payments of 5/1.

Send 5/1 only

**PETO-SCOTT WALNUT ADAPTAGRAPH** Beautifully constructed of solid walnut with contrasting Walnut Veneers. Ready to take your set and gramophone motor. Cash or C.O.D. Carriage Paid, £3/3/0. Balance in 11 monthly payments of 5/9.

Send 5/9 only

### PETO-SCOTT S.G.3 RADIO

A great technical achievement. Self-contained in one Cabinet of beautifully-grained walnut. High-grade components on all-steel chassis. Slow-motion single-dial tuning. Screened grid, detector and power valves.



Designed to give reliable Radio Reception in every part of the British Isles of B.B.C. and Foreign Programmes—Complete, ready to play, with Exide and Drydex Batteries and Aerial Equipment. Fitted Mullard Valves.

**SEND NOW 12/-**  
No Extra for Easy Terms

This is an honest-to-goodness offer from a firm established in 1910—solely for the purpose of building Wireless Sets and bringing radio within the reach of all. Peto-Scott himself gives every purchaser of his Set a personal guarantee of satisfaction. We give you credit over sixteen months, making no extra charge for Easy Terms. Carriage Paid complete with Aerial Equipment, £9/12/0. You send us 12/- with order and 3/- per week (paid monthly) for 15 months. This means you own the best British Radio money can buy.

**BLUE SPOT PICK-UP.** With arm, rotating head and volume control. Cash Price, only £3/3/0. Carriage Paid. Balance in 11 monthly payments of 5/9.

Send 5/9

**MARCONIPHONE PICK-UP K.17.** With counter balanced arm and rotating head. Cash only Price, £2/2/0. Carriage Paid. Balance in 7 monthly payments of 5/9.

Send 5/9

**COSSOR MELODY MAKER MODEL 334** with Metallised Variable-mu S.G. and Detector Valves, Power Valve and Cabinet. Cash Price, £6/7/6. Balance in 11 monthly payments of 11/10.

Send 10/- only

**COSSOR MELODY MAKER, MODEL 335.** Complete with Valves, Speaker and Cabinet. Cash Price, £7 17s. 6d. Balance in 11 monthly payments of 14/10.

Send 10/- only

### IMPORTANT. PIONEERS OF RADIO ON EASY TERMS IN 1934. WE SHALL BE PLEASED TO QUOTE YOU BY RETURN FOR ALL YOUR RADIO REQUIREMENTS. WE CARRY STOCKS OF ALL LEADING MANUFACTURERS' PRODUCTS ADVERTISED IN THIS JOURNAL. ANY PARCEL OF COMPONENTS OR ACCESSORIES. OVER £2 SUPPLIED ON EASY TERMS. SEND FOR NEW CATALOGUE.

### PETO-SCOTT CO., Ltd., 77, City Road, London, E.C.1.

Telephone: Clerkenwell 9406/7.

West End Showrooms: 62, High Holborn, London. W.C.2. Telephone: Holborn 3218.

Dear Sirs, Please send me CASH/C.O.D./H.P. for which I enclose £.....d. CASH/H.P. Deposit.

NAME .....

ADDRESS .....

Pr.W, 17/12/32

## STRICT PRIVACY GUARANTEED — WE DEAL WITH YOU DIRECT

# Build with your own hands — this better set! — save pounds — success a certainty!

**GET YOUR  
FREE COPY  
OF MOST SUCCESSFUL  
CHART  
EVER PUBLISHED  
enabling you to build  
MOST SUCCESSFUL  
SET EVER  
BUILT!**

**YOU ARE TOLD EXACTLY WHAT  
TO DO WITH EVERY  
SINGLE NUT  
AND SCREW**



**THE ONLY  
KIT YOU CAN  
BUILD YOURSELF  
EMPLOYING  
METALLISED  
S.G. HIGH-MU  
DETECTOR &  
ECONOMY POWER  
PENTODE VALVES**



**COMPLETE IN CABINET £6.5<sup>s</sup> OR 11/6 DOWN AND  
WITH LOUDSPEAKER TWELVE MONTHLY  
PAYMENTS OF 10/6**

Lissen have published a 1/- Constructional Chart, giving the most detailed instructions ever printed for the building of a wireless set.

You can't go wrong—you are told what to do with every part, every wire, every terminal—everything is identified by photographs. Everybody, without any technical knowledge or skill, can safely and with COMPLETE CERTAINTY undertake to build this most modern of radio receivers from the instructions given and the parts Lissen have supplied.

This new Lissen SKYSCRAPER Kit set is the only one on the market that you can build yourself employing a Metallised Screened-grid Valve, High-Mu Detector and Economy Power Pentode. Around these three valves Lissen have designed a home constructor's kit the equal of which there has never been before. Why be satisfied with whispering foreign stations, when you CAN BUILD WITH YOUR OWN HANDS this LISSSEN SKYSCRAPER that will bring in loudly and clearly distant stations in a profusion that will add largely to your enjoyment of radio?



*You can get the Lissen Skyscraper Chart FREE from any radio dealer, or by posting the COUPON below direct to factory.*

**NOW YOURS FOR ONLY 8/6 DOWN**

To day you can buy the LISSSEN SKYSCRAPER KIT on Gradual Payment Terms. Skyscraper Chassis Kit, complete with Valves, CASH PRICE 89/6. Or 8/6 down and twelve monthly payments of 7/6. Skyscraper Kit complete with Walnut Cabinet and inbuilt Loudspeaker, as illustrated, £6 5s. CASH; or 11/6 down and 12 monthly payments of 10/6.

**KIT COMPLETE INCLUDING  
METALLISED S.G.  
HIGH MU DETECTOR  
& ECONOMY POWER  
PENTODE VALVES** **89/6**

# LISSSEN SKYSCRAPER 3 KIT

**COUPON**  
Insert this COUPON in unsealed envelope with only halfpenny stamp and address to:—  
**LISSSEN LIMITED, Dept. P.W.14, Worpole Road, Isleworth, Middlesex.** Please send me FREE copy of your 1/- Skyscraper Chart.

Name.....  
Address.....

ARE YOU COLLECTING OUR DATA SHEETS? See Page 640



**Practical Wireless**

EDITOR:  
Vol. 1. No. 13. F. J. CAMM Dec. 17th, 1932.  
Technical Staff:  
H. J. Barton Chapple, Wh. Sch., B.Sc. (Hons.), A.M.I.E.E.  
Frank Preston, F.R.A., W. J. Delaney, W. B. Richardson.

## ROUND *the* WORLD of WIRELESS

### A Few Interesting Statistics

ACCORDING to a report recently published by the *Union Internationale de Radiodiffusion* at Geneva, some 138 million persons listen to the world's broadcasting programmes daily. In 1920, there were only two broadcasting stations—namely, in the United States; in 1930, the number in that country had increased to 750. At the end of that year Europe alone possessed 238 of the 1,105 transmitters in the two hemispheres. To-day, in Great Britain and the Continent, there are 250 stations with a total output of 4,600 kilowatts or an average of roughly 18 kilowatts per transmitter, a power far in excess of that used in the United States, where the mean energy works out at 2.3 kilowatts for a total of 600 stations.

### An Altered Wavelength

AS for some time reception of the broadcasts from the Leningrad (U.S.S.R.) station have been spoilt by morse signals emanating from fog beacons, several channels are being tested. This 100 kilowatt transmitter is now working temporarily on 857.1 metres (351 kilocycles), which, however, may not be definitely adopted as a final position.

### Super Power Transmitters Cause Trouble

COMPLAINTS have been received by the U.I.R. (*Union Internationale de Radiodiffusion*) Geneva from both Romania and France in respect to the channels adopted by the new Leipzig and Breslau stations, inasmuch as owing to their high power they swamp respectively broadcasts from Bucarest and Poste Parisien. A readjustment of wavelengths is asked for. Romanian listeners suggest that Leipzig should exchange channels with Berlin (Witzleben) or revert to its former position in the broadcast band—namely, 259.3 m. It is hardly likely that the latter wavelength could be allotted to this giant German station in view of its proximity to London National.

### New 300 Kilowatt Valves

THE Bisamberg (Vienna) station now under construction will be the first European transmitter to use 300 kilowatt valves made by the Telefunken Company. Up to the present in Germany the largest incorporated in the new plants do not exceed 150 kilowatts. If they prove successful they will be adopted in the new stations to be built at Berlin and Hamburg in 1933.

### Improving on Nature

IN view of its association with Pathé films, the Paris Radio Vitus station broadcasts the crowing of a cockerel as an interval signal. It is reported that the imitation is so lifelike that on a recent

occasion the wife of the announcer, hearing the noise, scolded her husband for leaving the hen-coop open. "The old rooster," she said, "has come into the dining-room!"

### Alternative Programmes for Berlin

IN a similar manner to Daventry National, the Königswusterhausen high-power station was originally installed to relay the capital programmes for the benefit of listeners outside the Berlin area. In future, however, steps are to be taken to broadcast an alternative entertainment through that transmitter as many of the capital programmes are taken by the provincial stations.

### Bringing the Turks Up-to-Date

BY the orders of Mustapha Kemal Pasha, President of the Turkish Republic, microphones and amplifiers have been installed in the Mosque Hagia Sophia, one of the oldest houses of worship in Constantinople. They are destined to the re-broadcast of sacred services through the Istanbul transmitter. As the present generation does not read the Koran in arabic, a special translation has been made for this purpose into the Turkish language.

### How the French Choose Their Announcers

LOUISE BIGORRE, a twenty-year-old girl who took first prize in a local beauty competition, has been engaged as announcer at Radio Toulouse; her duty consists in the broadcast of news bulletins.

### Another New Jugoslavian Station

ONE of the smallest European broadcasting transmitters, Radio Zagreb, will shortly be rated as a 15 kilowatt. Work was started on the buildings some months ago, and it is hoped to get the plant erected by the summer of 1933. The site of the new station is at Otok.

### Licence Round-Up in Belgium

FOLLOWING a general campaign against radio pirates initiated by the Post Office authorities the Belgian police have confiscated over eight thousand wireless receivers from listeners who failed to take out broadcasting licences.

### Continental Service for Motorists

THE German stations have recently introduced a special service for motorists on the lines of the transmissions made by the B.B.C. in respect to the state of the roads, etc. In Sweden a similar feature is also found in the programmes.

## IMPORTANT!

Readers please note that Gift Stamp (No. 13) the last for their Presentation

## WIRELESS

## CONSTRUCTOR'S ENCYCLOPAEDIA

will appear in next week's "PRACTICAL WIRELESS" on sale

Wednesday, December 21st.

Will readers who are qualifying for this Presentation Encyclopaedia affix the last Gift Stamp to their Subscription Voucher, and forward the completed Voucher in accordance with the instructions thereon, at once?

## PLEASE DON'T DELAY

There will be an enormous number of volumes to handle, and it will take some little time to get them all out. All applications will be treated in strict rotation, but it will be impossible to dispatch before the Christmas holidays. If you do not receive your volume within 21 days of posting your application—notify by post card giving date sent.

NOTE: Carefully read instructions on your Subscription Voucher and make sure it is properly filled in before forwarding.

## YOUR LAST GIFT STAMP APPEARS NEXT WEEK

Complete and send in your Subscription Voucher immediately you have the last Gift Stamp.

"Practical Wireless"

Presentation Department,  
39, King Street, Covent Garden,  
London, W.C.2.

# ROUND *the* WORLD of WIRELESS (Continued)

## Lanchester Speakers

**M**ESSRS. Lanchester's Laboratories, Limited, of Spring Road, Tyseley, Birmingham, manufacturers of the well-known Lanchester Speakers, who have hitherto conducted a Mail Order business direct with the public, are now adopting the generally-accepted policy of marketing their speakers and radio products through the Trade, subject, of course, to the usual price maintenance agreement.

No alteration has been made in the company's list prices, but nevertheless the customary full trade discount is allowed. This has been rendered possible by the more advanced methods of production to meet an increased output in support of the company's new policy.

## A Multi-Lingual Aerial Postman

**I**MITATING the feature introduced some four years ago by the Katowice (Poland) broadcasting station, Radio Ljubljana (Jugo-Slavia) in its "Letter Box" hour, replies by microphone to its foreign listeners in the Slovene, French, and German languages. The station can be identified by its cuckoo interval signal.

## A New Switzerland-Japan Radio Link

**T**HE Prangins (Geneva) wireless station is not used solely by the League of Nations, but devotes most of its time to official telephony services with foreign countries. As a result of experiments recently carried out, a regular two-way wireless communication has been established between Prangins and Kemikawa (Japan), the former station working on 38.476 m., the latter on 38.07 m.

## Achtung! Hier der Rote Sender

**T**HE Berlin Police have been considerably mystified by broadcasts put over the ether and which apparently emanate from an unlicensed transmitter on 300 metres. During the recent Reichstag elections, transmissions were made daily, and the speakers gave considerable publicity to the Communist programme. The call is: *Hier der Rote Sender*. (This is the Red Transmitter.)

## Wired Wireless in Switzerland

**T**HE distribution of the Swiss broadcasting studio programmes has now been introduced in twenty-five different towns in that country, and over 5,000 subscribers have already been registered. The service is undertaken by the Swiss Telephone Administration. At present only one programme is available, but in future alternatives of a further Swiss and a foreign broadcast are to be given to listeners.

## Private Broadcasting Resources in Holland

**T**HE *Algemeene Vereeniging Radio Omroep* (A.V.R.O.), which at present organizes most of the transmissions broadcast through Hilversum, possesses 175,000 supporters. To ensure a regular income for defraying programme expenses, each member pledges himself to pay a sum equivalent to roughly ten shillings per annum.

## INTERESTING and TOPICAL PARAGRAPHS

### Take Your Radio With You

**U**P to the present travellers to the Continent have encountered difficulties with the Customs when taking portable wireless sets with them.

The *Office National du Tourisme* (France) has now induced the authorities to permit tourists to enter and leave the country with their wireless receivers. All that is needed is to declare the set on arrival at the

### AT THE RUGBY STATION

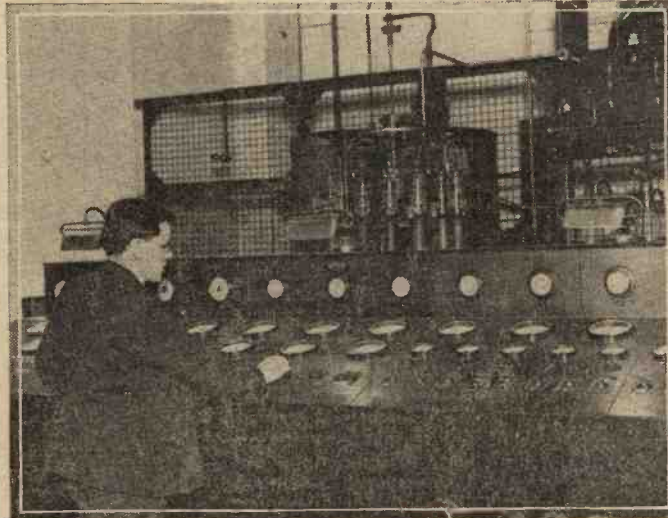

A view of the Control Table.

French port and a special certificate will be handed to the traveller.

In Italy, on payment of a fee amounting to one shilling and sixpence per month for a period not exceeding three months, British tourists are authorized to take portable sets

# SOLVE THIS!

### PROBLEM No. 13.

Jenkins had made a standard three-valve set, using the Detector and 2 L.F. arrangement. After using this for some time he developed a craze for Short Wave reception and accordingly bought a Short-Wave Converter. He connected this to his set, but it failed to work. The Converter and the set were both in working order. What was the reason? Three books will be awarded for the first three correct solutions opened. Mark envelopes Problem No. 13, and send to the Editor, PRACTICAL WIRELESS, Geo. Newnes, Ltd., 8-11, Southampton Street, Strand, London, W.C.2, to reach us not later than December 19th.

### SOLUTION TO PROBLEM No. 12.

The frame aerial of a Portable receiver is, of course, of such a size that it is employed instead of a tuning coil. By joining this in series with a further coil Rogerson used the whole of the frame (including the long wave winding), and so his minimum tuning point was over 1,000 metres.

The following three readers receive books in connection with Problem No. 11.

L. Witcombe, c/o 154, Conran Street, Starpurhey, Manchester; J. Jardine, 59, Loreburn Street, Dumfries; E. Keene, 10, Green Wrythe Lane, Carshalton, Surrey.

into the country. The usual formalities can be gone through at the customs, or the necessary form obtained in advance from any Italian Consulate, or Tourist Agency. It is expected that other European countries will follow this good example.

## The New Vienna High-Power Station

**A**LTHOUGH every effort has been made to hurry on the construction of the 100 kilowatt transmitter at Bisamberg, there appears little likelihood that it will be ready to carry out its initial tests before January, 1933. In the meantime in addition to the main broadcasts on 517 metres, the Vienna concerts may also be heard through the experimental station on 1,237 metres.

## Jerusalem-London via New York

**I**T is reported that the National Broadcasting Company of America has made all arrangements to relay a Sacred Service from the Franciscan Church at Bethlehem on Christmas Eve. The transmission will be rebroadcast in the United States. European listeners will be given the opportunity of picking up this broadcast through the Schenectady shortwavers (W2XAD, W2XAF) and other stations in the N.B.C. network (W3XAL, Boundbrook, etc.), or through German transmitters who intend to relay it.

## From Barracks to Broadcaster

**T**HE building used for housing the 2½-kilowatt transmitter now in course of construction at Treves (Germany) has, since its erection shortly before the War, been put to many uses. Originally intended as Cavalry barracks, it was taken over by the French during the occupation for their coloured troops, and later as a military hospital. The transmitting plant is now being installed in the stables. It is the plant previously in operation at the Leipzig station.

## New French Titan

**T**HE French State Posts and Telegraphs department has decided to erect a 60-kilowatt transmitter in the environs of Nice, to take over the functions up to the present privately carried out by the little Juan-les-Pins station. The reason given for the use of this high power is the facility which would thus be secured for the broadcast of special publicity talks likely to attract foreign visitors to the French Riviera.

## Another German Giant

**L**EIPZIG is testing on about 390 metres with a power of 120 kilowatts and is expected to be working a regular service by now. If it was this station I heard concluding a test transmission late the other night, I am afraid we shall be in for more trouble in the region of Midland Regional. With Athlone a few metres above and Leipzig a few below, some of the older sets will be incapable of receiving M. R. without interference.—JACE.

# A.C. VALVES and MAINS WORKING

An Article on Obtaining D.C. from A.C. Supply and How it Operates the Indirectly Heated Valve

By GILBERT E. TWINING

## A.C. Valves

INDIRECTLY heated A.C. valves, as most people are aware, work from the house lighting alternating current mains. But before this supply can be utilised it has to be rectified or changed into D.C.—direct current. The only part of the valve which takes raw A.C. is the filament (heater element), which is so constructed that it is possible to connect it direct to the mains transformer, which has an auxiliary winding, transforming the current down to 4 volts. A.C. changes

its polarity, that is to say, it rises and falls in one direction, and then rises again in another, some fifty times per second; this fluctuation of the current tends to cause continually a heating and cooling of the filament, and if this filament were used to emit electrons, as in the case of battery valves, a very bad hum would occur on account of these fluctuations. But the filament does not emit electrons, its action is to indirectly heat what is known as the cathode. This cathode

surrounds but does not touch the actual filament, and therefore, as the cathode obtains its heat by conduction, it is enabled to maintain a constant temperature, and thus emit a steady flow of electrons. The space of

time which the filament takes to heat the cathode is very noticeable when first switching on the set, for, although the set is tuned to a station which is broadcasting some little time elapses before the programme is heard; it is only when the cathode reaches its normal working temperature that the valve functions correctly, and the cathode is able to emit or throw off electrons.

## The Electrodes of an A.C. Valve

As may be seen in Fig. 1, there are four distinct parts in an indirectly heated valve, all isolated from each other; these parts are known as electrodes, the centre electrode is the filament or heater element, marked F in the illustration, surrounded by C, the cathode; this cathode is in the form of a tube, and encircling it is the grid, marked G, which is a spirally wound length of wire, surrounded in its turn by A, the anode. In Fig. 2, marked A.B.C.D., are shown these parts drawn independently of

each other, together with their respective sockets in the valve holder.

## The Cathode

The electrons, which are minute electrical negative charges, emitted by the cathode, pass through the grid to the anode. To attract these negative electrons to the anode from the cathode, the anode is kept positively charged, for in electricity a positive charge will attract a negative charge. Therefore, to positively charge the anode it is connected to H.T. positive. The grid, as before stated, is between

the cathode and the anode, and it is to this grid that the incoming signals are applied. These signals are alternatively negative and positive; this changing of polarity tends to control the electron flow from the cathode to the anode, for when the grid is positive it acts like a small anode and because it is nearer the cathode its attraction is much greater. The grid, however, is just as often negative, and has the effect of repelling electrons leaving the cathode, for like repels like.

As previously mentioned, the grid is the electrode to which the incoming wireless signals are applied. These signals

are made up of two frequencies, high frequency and low frequency. The action of the detector valve in a set is to demodulate, i.e., separate these, retaining the sound waves (low frequency) and dispersing the carrier waves (high frequency currents). The low frequency currents are the variations which, when amplified by the power valve, go to actuate the loudspeaker.

## The Anode Current

Before it is possible to derive the anode current for the valves from A.C. supply, it is first necessary to obtain a mains transformer having two windings, a primary, which is connected to the mains, and a secondary connected to the rectifier. The

transformer does not change the nature of the current with which it is supplied, it merely alters the voltage on its secondary winding; for instance, if there are less turns of wire on the secondary—as in the case of a 4-volt low-tension winding—then the voltage is lower, and in the same way if more turns are wound on the secondary, the voltage is raised. Thus it is possible to understand that the only change the transformer can make in the A.C. supply current is to alter the voltage to that required for the rectifier, etc. It must be remembered, however, that it is still fluctuating alternating current. Therefore, after the current is changed to the required voltage, it still has to be rectified from A.C. to D.C., i.e., direct current. This is the work of the rectifier, which is either a valve or metal rectifier. When the current has been made to flow in one direction only, it has to be smoothed, which means

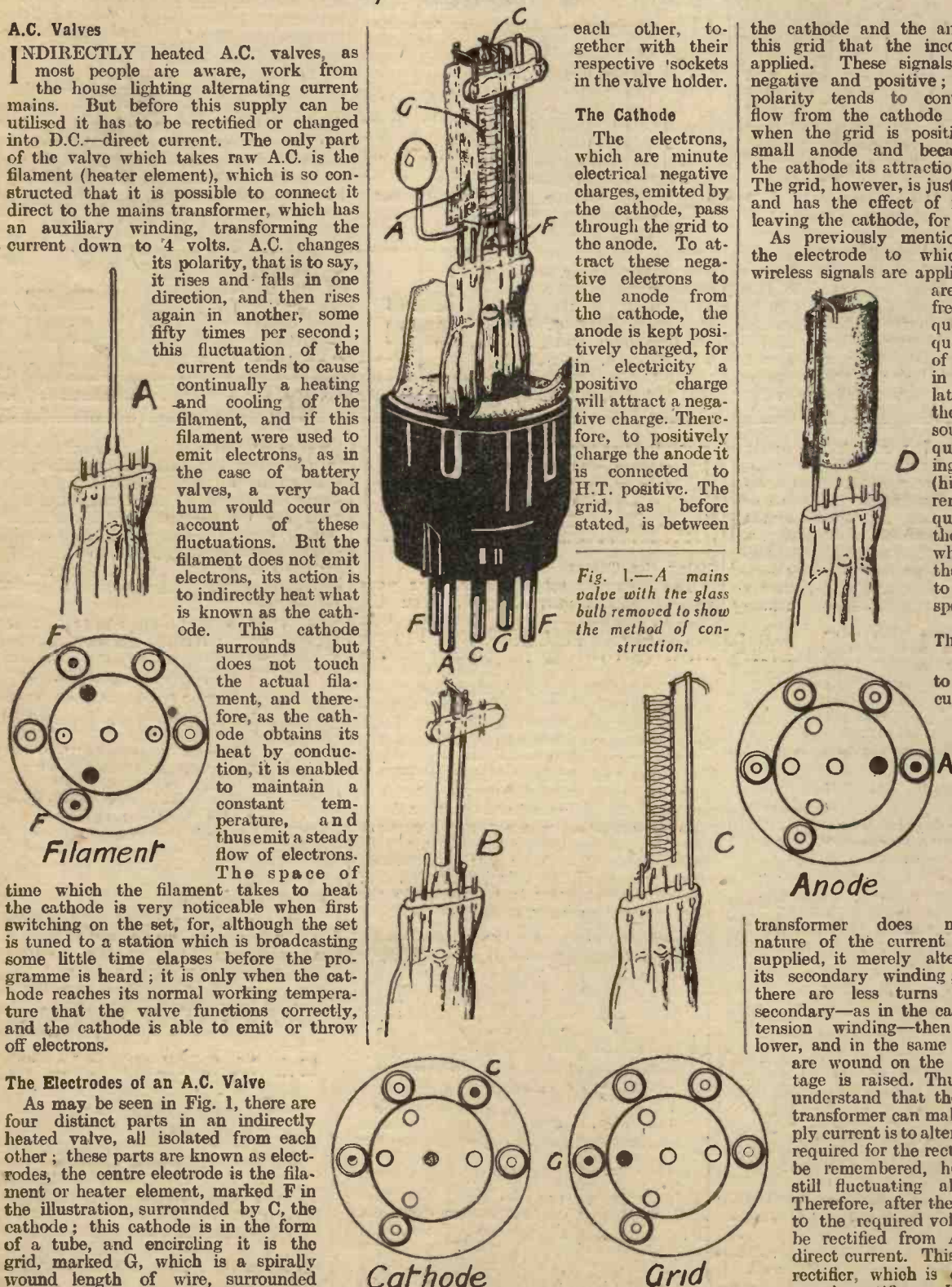

Fig. 1.—A mains valve with the glass bulb removed to show the method of construction.

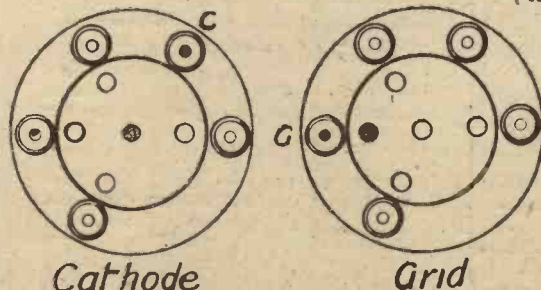

Fig. 2.—A, B, C & D—The separate component parts of a mains valve, showing the relative pins to which they are connected.

all traces of ripple and pulsation are obliterated. This is undertaken by two condensers and a choke. The latter tends to stop any changes in the current flowing, and the

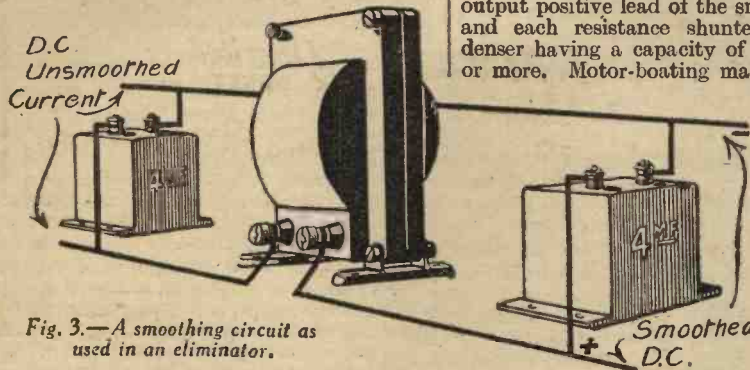

Fig. 3.—A smoothing circuit as used in an eliminator.

in a set do not take the maximum value of high tension. The best way to obtain the correct values is to drop the voltage down with resistances inserted in the output positive lead of the smoothing unit, and each resistance shunted by a condenser having a capacity of 2 microfarads or more. Motor-boating may occur if too low a value of resistance or capacity of condenser is used, and it might be found necessary to increase the condenser to 4 micro-

of anode current feeding the valves in their individual circuits are separately fed, that is to say, if they have their own filter circuits comprising a resistance for lowering the voltage and a by-pass condenser, then there will be less chance of interaction between the circuits; secondly, that the resistances are of the correct value, and thirdly, that the grid bias resistances are right for the anode voltages employed. The mains unit should be kept a little distance from the set for hum may be introduced by placing it too close. It should certainly be kept right away from the early stages of amplification, for hum may be introduced into the receiver circuit and amplified by the various stages following. It is also very advisable to enclose the complete unit in an earthed metal box.

condensers help to maintain the voltage when the current does change. The condensers are shunted across the H.T. leads, and the choke is in series with the H.T.-lead between the two condensers; this is plainly shown in Figs. 3 and 4. The resultant current is then ready to be supplied to the various anodes of the valves, except for the fact that all the valves

farads. A slight variation in the supply to the detector valve may be so magnified by the low-frequency part of the set that hum and noise will be heard. The chief points to note are, firstly, that the different values

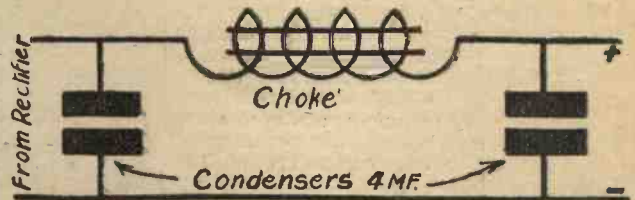

Fig. 4.—The arrangement of Fig. 3 shown in diagrammatic form.

IN the course of a search for foreign broadcasts it happens frequently that morse transmissions are heard. Although these signals may prove, at times, an annoyance, the listener may put them to a very useful purpose. Unfortunately, we are not all experts in reading this alphabet, although many of us may actually know the equivalents of letters and figures as used by the telegraph operator. In many

E	I	S	H	5	FULL STOP
A	R	U	F	V	4
W	P	Ü			3
J					2
I					1

Table No. 1.

instances it will be found that the stations when putting out their call-signs do so fairly slowly, and it is useful to log the transmissions by noting the condenser dial readings of the particular wavelength on which the signals are heard. If the call is identified it is always possible to ascertain this wavelength from published lists, and the information thus obtained will assist greatly in calibrating a wireless receiver. In particular, this will apply to users of instruments specially constructed for the reception of transmissions on wavelengths below the broadcast band. If the condenser readings of a known frequency are logged it is a simple matter to search for another station, of which the wavelength is also known, as the data previously collected will allow you to set the condensers at the start, approximately at the tuning point of the frequency desired.

### LOGGING MORSE CALLS

#### Using the Tables

The following tables placed near your receiver should prove helpful. You will notice that No. 1 table starts with a dot (.) and No. 2 with a dash (—). As you hear the first signal of the call you will immediately glance at either No. 1 or No. 2. Supposing, as an example, we take the call-sign: WML (.— — — . . .).

As it starts with a dot we look at the first line (table 1), then follows a dash (immediately underneath) and another dash, also underneath, in the vertical column. We read off the letter: W. Now, second letter begins with a dash (table 2), another dash (same horizontal line); we read off: M. The third letter is dealt with in the same manner, namely, initial dot (table 1),

T	M	O	ch	O	Fig
N	K	G	Q	Ö	9
D	X	Z			8
B					7
					6

Table No. 2.

a dash (underneath), a further dot (to the right of A in table) and a final dot slightly above, in the same direction. We read off: L. The written explanation may, at first sight, appear somewhat complicated, but if you study the table for a few seconds you will see that the method adopted is a simple one. In actual

practice but little difficulty is encountered in following the call on the tables providing the transmission is relatively slow. Moreover, if you do this a number of times your ear will become accustomed to the sounds, and in a very short space of time you will memorise the letters so thoroughly by their sound that the tables can be dispensed with. The system is an excellent one for the amateur or listener who is not a proficient reader of morse signals and obviates the alternative of writing down on paper from memory the letters identified and leaving blanks for those which cannot be immediately recognised.

Before proceeding with a call or transmission, test signals by stations are frequently made in order to adjust apparatus. These are the V (.— —) signals with which we have become so familiar. They must not be made by any transmitter for more than ten seconds at a time and are invariably followed by the call-letters of the sending station.

The letters CQ often heard at the beginning of a call mean that the message is intended for all who can hear, and means simply "All Stations."

**FREE NEXT WEEK!**  
**DATA SHEET No. 2,**  
**ENTITLED**  
**"COILS & COIL WINDING"**

If you are a **REGULAR** reader, turn to page 643.

The complete series of data sheets will provide you with a complete guide to the facts of Home Construction!



# Simple Experimental Makeshifts

Described by FRANK PRESTON, F.R.A.

Temporary Measures to Try Out Before Fitting New Components; and Other Useful Hints.

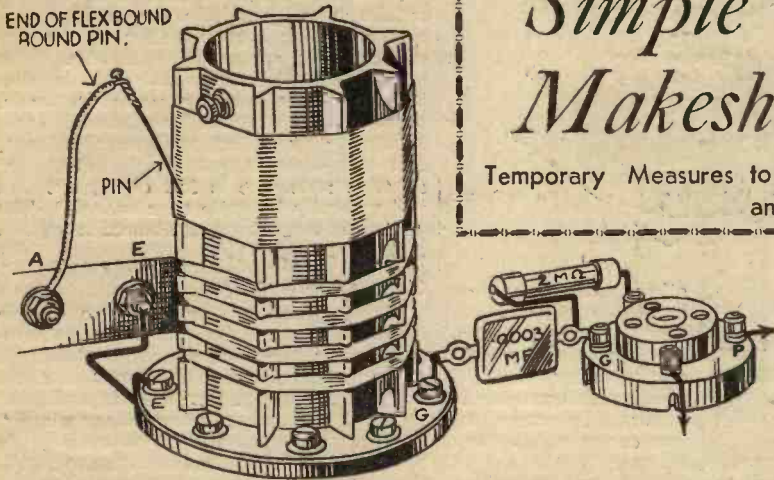

Fig. 2.—Finding the best position for an aerial tapping.

IN the course of his experiments and tests the constructor is often in need of some little component or gadget which he has not got on hand. In most cases the part is only required for a single trial and it would scarcely be worth while to buy a new one. But it is often possible by the exercise of a little ingenuity to devise a makeshift component that will serve the purpose. Below I propose to mention a few of the more useful makeshifts in the hope that some of them will be helpful to readers who are of an experimental turn of mind.

### Series Aerial Condenser

At some time or other we all wish to try the effect of increasing selectivity by connecting a small-capacity condenser in series with the aerial lead-in. Unless a condenser is available with a capacity less than about .0002 mfd. the change is not likely to give very much improvement. When the object of the series condenser is to reduce the aerial input and so prevent overloading by the local station a still lower capacity is required, and in many cases even a pre-set condenser cannot be adjusted to a sufficiently low value. The difficulty can be overcome, as shown in Fig. 1, by making use of a length of twin flex. One of the wires is joined to the aerial terminal on the set and the other to the lead-in. The two wires form a condenser, of which the capacity can be varied by altering the length of flex or by untwisting it at one end. If it is desired to make the "condenser" a permanent fitting the flex can be coiled up and accommodated in a corner of the set. The two wires must not touch each other or the condenser effect will be lost.

### Tapping the Aerial Coil

Another well-known way of increasing selectivity is to connect the aerial to a tapping on the aerial tuner. Before making a permanent tapping a certain amount of experiment is necessary to determine the best position for it. The simplest way to find the best tapping position is to remove the wire between the aerial terminal and the end of the coil, replacing it by a short length of flex to the end of which is attached

an ordinary pin. By pushing the pin between turns of the winding as shown in Fig. 2, contact can be made at different points. If the winding consists of enamelled wire the insulation must be scraped away by the pin point before proper contact can be made. When the winding is in silk or cotton-covered wire the pin can simply be pushed through the insulation.

The method just described can also be employed when

the set is used away from home it would be inconvenient to make connection to earth, although a temporary aerial could easily be fixed around the room. Quite a good "counterpoise" or "balanced" earth can be obtained in one of two ways. The better one is to take a second wire round the room parallel to the aerial and connect this to the earth terminal. The other way is to lay a coil of wire in the base of the cabinet and connect one end of this to the earth terminal. Both "earths" referred to will have a tendency to stabilise the set and simplify tuning.

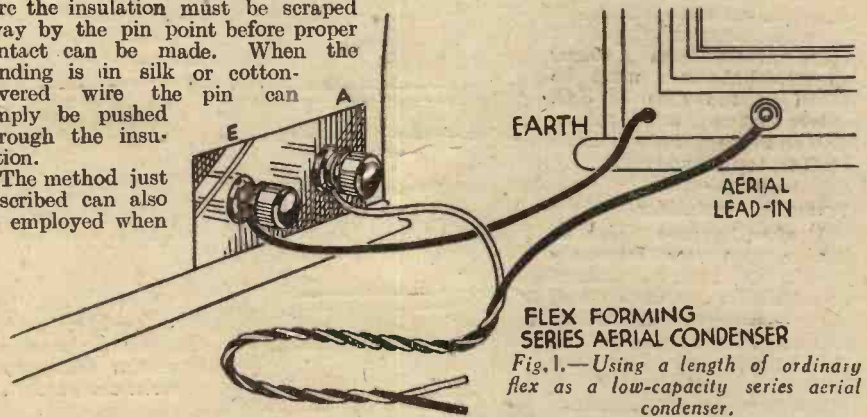

Fig. 1.—Using a length of ordinary flex as a low-capacity series aerial condenser.

the coil is a little too big to enable you to tune down to the lower wavelengths. In the latter case, however, all the wires should be removed from one end of the coil, connected together and attached to the flex, with pin contact.

### A "Balanced" Earth

When increased range is required from a portable set it is usual to connect aerial and earth wires. In many cases when

### Home-made Grid Leaks

In the event of a set making "hissing" and crackling sounds, suspicion is liable to fall on the grid leak. If a spare is not available for comparison you can make one quite easily as shown in Fig. 3. A heavy line about 1 in. long and a 1/4 in. wide is made on a strip of card with a soft pencil. Two pencil discs are drawn at each end of the line and terminals are fitted through the centres of these. A grid leak made in this way should not be kept in use permanently because its resistance will vary with the dampness of the atmosphere. If you find it so satisfactory that you wish to keep it in use, you can make it more permanent by giving it a good coat of shellac varnish so as to exclude all moisture.

### Metallising Your Valves

Having read of the advantages of metallised valves, perhaps you would like to try the effect of metallising your old ones. You can do so easily, and even if the process does not effect an improvement, it can certainly do no harm. The cheapest way is to put a thin coat of glue or gold size over the glass bulb and press a sheet of tinfoil on to it, working the foil to fit neatly over the glass. The screen must, of course, be connected to earth, and this is done by taking a wire from it to one filament pin—the correct one is indicated in Fig. 4. A length of bare copper wire, about 24's gauge, is bound round the foil, and its loose

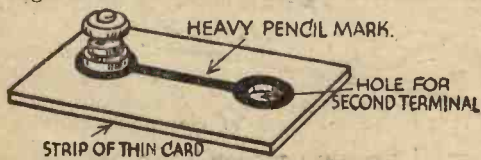

Fig. 3.—A makeshift grid leak.

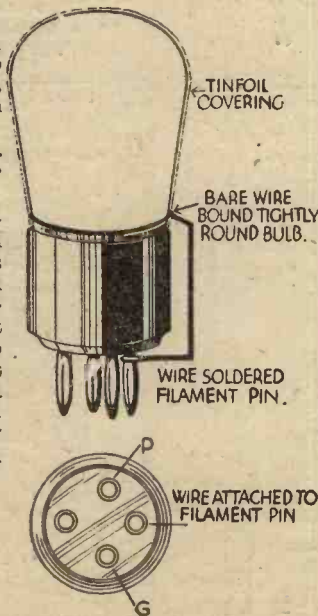

Fig. 4.—Metallising old valves.

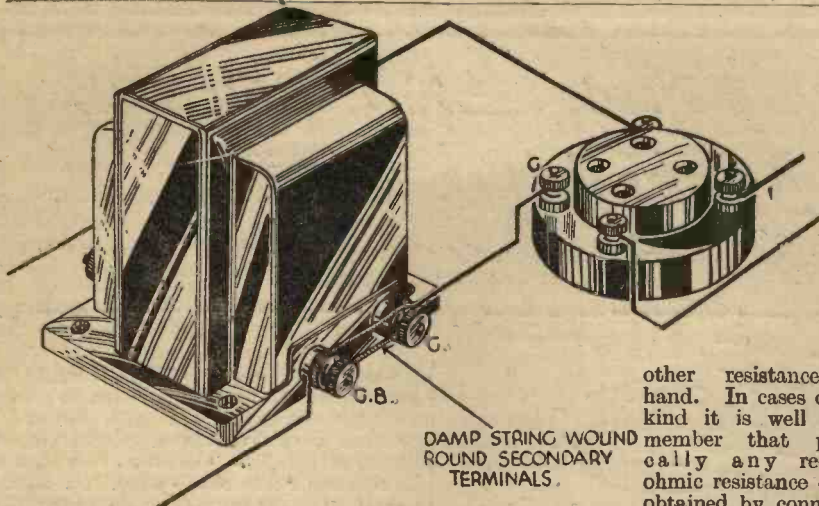

Fig. 5.—A piece of damp string used as a stabilising resistance.

end is twisted round, and soldered to, the filament pin on the cap. A neater job results if the valve is metallised by coating it with aluminium powder (obtainable from colour stores), but care must be taken in the case of S.G. valves that no powder finds its way on to the bakelite terminal bush on top of the bulb.

**Preventing Instability**

It often happens with a set having two low frequency stages that a certain amount of instability (in the form of L.F. howling and distortion) occurs. This might be due to a number of things, not least of which is bad design, but a remedy can often be applied in the form of a quarter megohm grid leak connected across the secondary terminals of one or other of the L.F. transformers. When a suitable grid leak is not available a test can be made by winding a length of damp string around the terminals in indicated in Fig. 5. This remedy will only be a temporary one, but it will enable you to tell whether or not it would be worth while to buy a proper grid leak for the purpose.

**Burnt-out Resistances**

The same idea is useful when it is suspected that a decoupling resistance is burnt out; the string should be wound round the resistance terminals to form a temporary resistance. Should it be found that the resistance is at fault, the set can be kept in operation for the whole evening by occasionally dropping a little water on to the string.

**Awkward Values of Resistance**

I have no doubt that you have often wanted a resistance of a value you hadn't got, although you had several

DAMP STRING WOUND ROUND SECONDARY TERMINALS.

other resistances on hand. In cases of this kind it is well to remember that practically any required ohmic resistance can be obtained by connecting two or more resistances in series or parallel. When resistances are put in series (end to end) the combined resistance is equal to the sum of individual ones. For instance, if resistances of 500 ohms, 1,500 ohms and 2,000 ohms were connected in series they would offer a total resistance of 4,000 ohms (see Fig. 6 (a)). When resistances are wired in parallel the effective

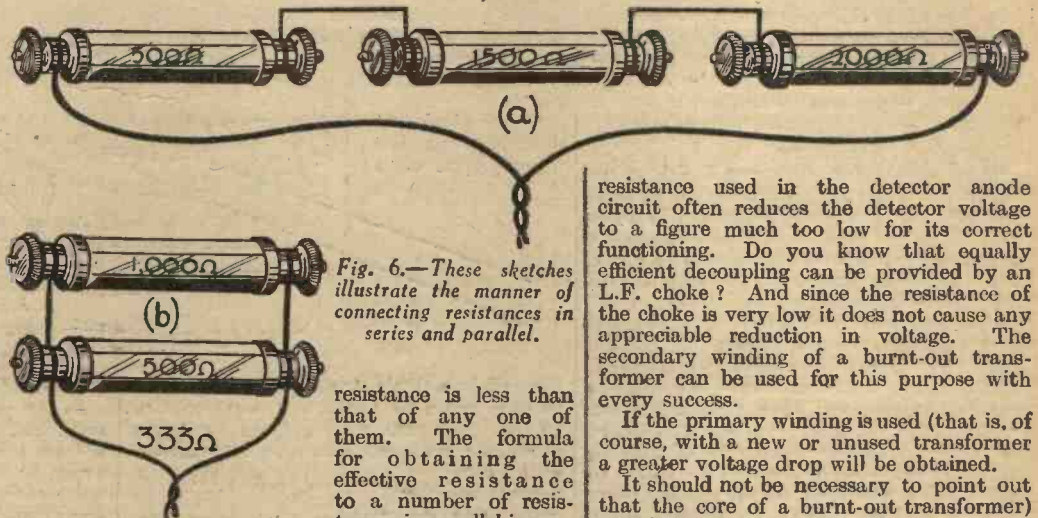

Fig. 6.—These sketches illustrate the manner of connecting resistances in series and parallel.

resistance is less than that of any one of them. The formula for obtaining the effective resistance to a number of resistances in parallel is:—

$$\text{Effective resistance} = \frac{1}{1/r_1 + 1/r_2 + 1/r_3 + \text{etc.}}$$

where  $r_1, r_2, r_3$ , etc., are the resistances of the separate components.

It is very useful to be able to connect resistance in parallel when a low non-standard value is required for the purpose of providing automatic grid bias. For example, a resistance of 300 ohms is often required; this is not a standard size in most makes, but can be obtained fairly accurately by putting resistances of 1,000 and 500 ohms in parallel. (The actual effective resistance is 333 ohms, but this will generally be quite near enough.) The method of connecting resistances in parallel is shown in Fig. 6 (b).

**Choke-capacity Output**

Stability and general performance can often be improved by connecting the loud-speaker on the choke-capacity principle. If your output valve does not consume more than three or four milliamps of H.T. current you can use the secondary winding of a burnt-out transformer as a choke by connecting it in the manner shown in Fig. 7. Choke-capacity loud-speaker coupling has many advantages which have been dealt with in past issues of PRACTICAL WIRELESS.

**Decoupling with L.F. Choke**

When the high-tension battery has a voltage of less than 80 or so, the decoupling

resistance used in the detector anode circuit often reduces the detector voltage to a figure much too low for its correct functioning. Do you know that equally efficient decoupling can be provided by an L.F. choke? And since the resistance of the choke is very low it does not cause any appreciable reduction in voltage. The secondary winding of a burnt-out transformer can be used for this purpose with every success.

If the primary winding is used (that is, of course, with a new or unused transformer a greater voltage drop will be obtained.

It should not be necessary to point out that the core of a burnt-out transformer) may be used as the basis of a new home-made choke, with a winding to meet any special requirements.

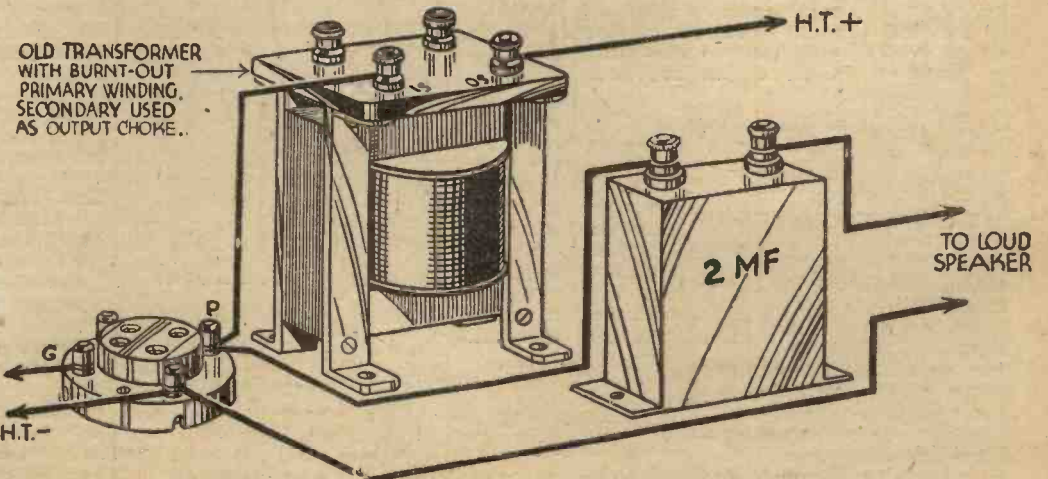

Fig. 7.—Using the secondary winding of an old transformer as output choke.

# Thinking in Terms of Frequency

(PART 1)

By

H. J. BARTON CHAPPLE,  
Wh.Sch., B.Sc. (Hons.), A.C.G.I.,  
D.I.C., A.M.I.E.E.

IN scientific parlance, if any phenomenon varies or repeats itself at regular intervals of time, it is said to be "periodic." There are many such periodic effects in Nature—the swinging of a pendulum, the ebb and flow of the tides, the air vibrations we call "sound" and the electro-magnetic disturbances known as light, heat and—radio waves. One complete change of vibration is called a "period" or "cycle" and the time taken for one cycle is the "periodic time," while the number of complete periods or cycles occurring in one second is known as the "frequency."

All this sounds very nice and learned; but let us try to translate it into somewhat simpler terms for the benefit of newcomers to radio. The drawing reproduced in Fig. 1 represents an apparatus in which a pen arm "P" is caused by some mechanism to move across a paper strip, the limit of its travel on either side of the centripetal position A being indicated by the lines BB and CC. Mechanism is also employed to wind the paper from the drum "X" on to the drum "Y," the speed of the paper being, say, ten inches per second. It will be clear that because the paper is moving forward and the arm is moving from side to side, the pen will trace out a wavy line or curve as indicated on the drawing. The complete cycle will be from the original position A over to the line BB, back to A, over to the line CC, and back to A again.

As suggested, we will assume that the mechanism operating the pen arm is adjusted so that one complete cycle occupies one-tenth of a second. It will be evident, then, that while the paper is travelling 10in. (in one second), one complete cyclewave will be traced every tenth of a second, and that ten complete "waves" will be formed in that second, each wave occupying a space of 1in.

It will thus be seen that the frequency in this case is ten cycles per second, and that the "wavelength" is 1in. This gives us at once the fundamental relationship between frequency, wavelength and periodic time, namely:—

(1) Frequency equals one second divided by the periodic time in seconds.

(2) Frequency multiplied by wavelength equals speed of wave. This second equation can be restated in the following useful forms:—

(3) Frequency equals speed of travel divided by wavelength.

(4) Wavelength equals speed of travel divided by frequency. We shall see later how these formulæ can be of considerable

service, but a reference to Fig. 2 will make the matter clear.

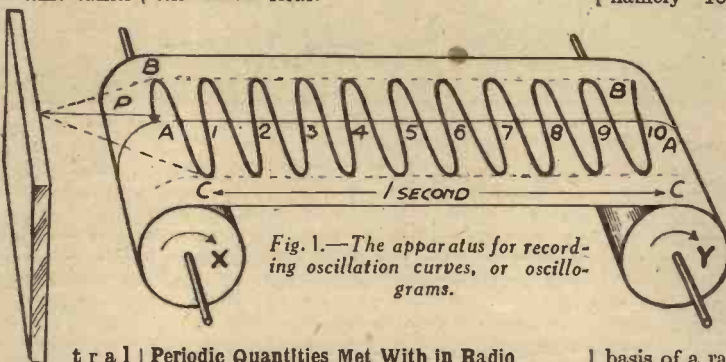

Fig. 1.—The apparatus for recording oscillation curves, or oscillograms.

### Periodic Quantities Met With in Radio

The periodic quantities which have to be dealt with in radio practice are first,

produced by the movement of the instrument (voice or mechanical) creating the sound. Sound vibrations range in frequency between a few dozen to many thousands of cycles per second.

Radio waves are electromagnetic disturbances in the ether of space, and partake of the same nature as heat, light, X-rays and other forms of radiant energy. The speed of all these waves is the same, namely 186,000 miles per second, or 300,000,000 metres per second; and the only difference between the various types of wave lies in their frequencies and the effects they produce.

Thus, light-waves stimulate the eye, giving rise to the sensation of sight; heat is perceived by the nerves, and produces the chemical effect known as burning. Radio waves, however, do not appeal directly to any of our senses, although they can be detected by the special type of apparatus which forms the basis of a radio set. The difference of frequency between the various forms of wave is, however, very great. The "radio" frequencies, used for ordinary broadcasting, range from about 150,000 cycles per second up to about one and a half million cycles per second. The so-called "short" waves have frequencies which range up to over twenty million cycles, while experimental work has recently been carried out on exceedingly short waves corresponding to frequencies up to one thousand million cycles.

The heat rays have frequencies very much in excess of these figures; light rays are still more rapid vibrations, the frequency of yellow light being of the order of five hundred million million cycles per second, while it is almost impossible for the mind to grasp the enormous frequency of the lesser-known radiations beyond the light and X-rays, the wavelengths of which are measured in ten millionths of a millimetre.

What are "High" and "Low" Frequencies

### What are "High" and "Low" Frequencies

For our purpose, however, we must confine ourselves to the more easily comprehensible frequencies of radio waves and sound vibrations. Unfortunately much confusion has been caused by the loose use of the terms "high" and "low" as applied to frequencies. Many engineers and writers apply the term "high frequency" exclusively to radio waves, and "low frequency" to sound. This is a very unfortunate and unwise use of the words, for "high" and "low" are purely relative terms and relative terms should never be applied to specific quantities. It must be kept in mind that both radio waves and

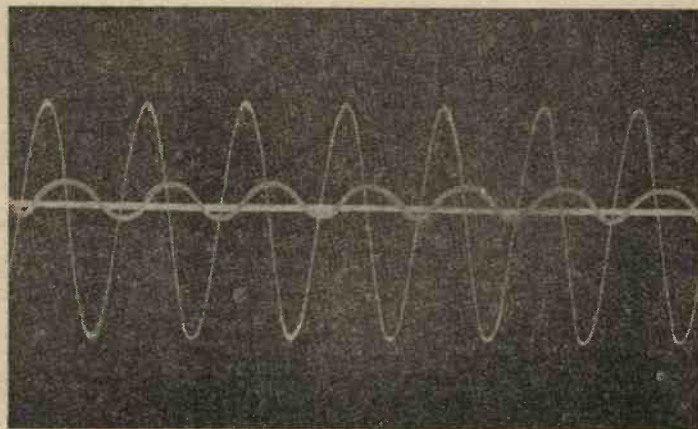

Fig. 3.—Plate current and oscillating circuit current when coupling is tight.

sound waves; second, radio waves; and third, electric currents varying at the same frequencies as sound and radio waves.

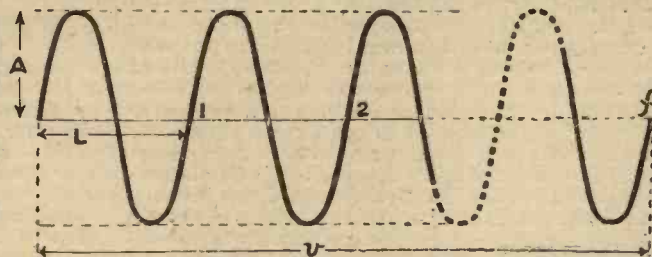

Fig. 2.—A="Amplitude" or "Peak" value. l=Wavelength. V=Distance travelled in one second (speed or velocity). F=Number of cycles in one second (frequency).

Before considering the importance and significance of the term "frequency" in connection with these effects, it will be of advantage to set down the nature of the waves themselves. Sound is merely a succession of vibrations of air pressure,

and unwise use of the words, for "high" and "low" are purely relative terms and relative terms should never be applied to specific quantities. It must be kept in mind that both radio waves and

sound waves cover wide ranges or "bands" of frequencies, and it is, of course, impracticable and clumsy to speak of the "high high-frequency" and the "low high-frequency" waves, or of the "high low-frequency" or the "low low-frequency" waves and so forth. In this article, therefore, the frequencies used for radio transmission will always be referred to as the "radio frequencies" and the band of sound frequencies as "audio frequencies."

#### Radio Frequency

Because the radio frequencies cover such a wide band, it is necessary to sub-divide them in order to study their particular properties, and it is convenient to separate them into four groups. The most widely used band is that commonly called the "broadcast" band, which ranges in frequency between half a million up to one and a half million cycles per second, or from five hundred to one thousand five hundred kilocycles, one kilocycle being one thousand cycles. These frequencies correspond to wavelengths between 600 and 200 metres. Generally referred to as the "medium" waveband, it may, if considered on a frequency basis, be also termed the "medium frequency" band.

A very large proportion of broadcasting stations operate on this band, which is most convenient and efficient for transmissions of moderate to large power intended mainly for reception within a range of a hundred miles or so. Of course, transmissions on the medium band can be received over very much longer distances, provided adequate power is radiated and the receiving apparatus is sufficiently sensitive, but for really reliable results the practical range is limited to a few hundred miles, as these medium waves are very prone to the effect known as "fading," the true nature of which is not yet known.

A considerable number of broadcasting

stations of the high power type employ frequencies lower than half a million, the present extent of this band being down to 155,000, corresponding to wavelengths between 600 metres and about 2,000 metres. These wavelengths are usually termed the "upper broadcast waveband," and may therefore be considered as the "lower broadcast frequency band." Daventry 5XX

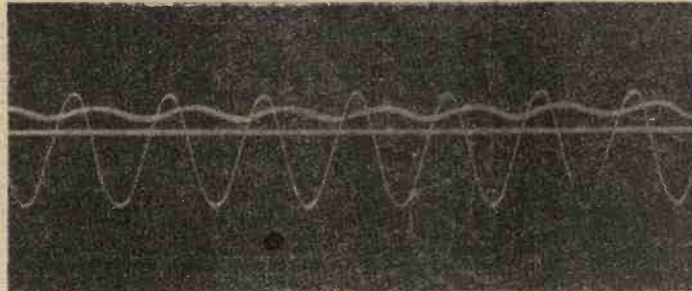

Fig. 4.—Plate current and oscillation circuit current when valve is just oscillating.

(193,000 cycles); Radio-Paris (174,000 cycles) and Hilversum (160,000 cycles) are well-known stations on this band. These lower frequencies have, apparently, greater range than the medium broadcasting band, and are almost free from the risk of fading.

We now come to another important frequency band, but one which has not yet been exploited to the full, so far as broadcasting is concerned, at any rate in this country, although the latest lists give the names of nearly one hundred stations in Europe and abroad operating on this band. This is the so-called "short-wave" band, or, as we must call it, the "high-frequency" band, extending from a frequency of a few millions up to about twenty million cycles per second, that is to wavelengths down to about 15 metres. These very rapid waves are essentially long-distance waves, and are also singularly free from fading. They possess another very useful property, namely, that they appear to travel as well during the day as by night,

or even better, whereas the normal broadcast bands lose a considerable amount of their power during the day.

The "high" radio frequency band, therefore, is being developed mainly for long-distance Empire and international services, both broadcast and commercial. For the latter application, the fact that the waves can, to a certain extent, be "focused" or concentrated into a comparatively narrow beam, results in economy of power, longer range, and a useful degree of secrecy.

The "ultra-short" wave or "ultra high-frequency" radio waveband using frequencies of the enormous value of hundreds or even thousands of millions of cycles per second, are as yet only in the experimental stage. As frequency is increased, up to a point, the properties of these waves seem to be an extension of those of the ordinary high-

frequency band. Still more rapid (shorter) waves, however, exhibit different properties. Some are less "penetrating"—that is to say they have a more limited range, but they appear to approach nearer the nature of heat or light waves, for they can be more accurately focused, directed and reflected. Very little information has been published concerning these waves, but recent experiments indicate that they may eventually form the basis of very efficient, short-distance, secret communication.

The two photographs which accompany this article are particularly interesting as they are actual photographic records of oscillations taken with the aid of an oscillograph. They indicate how currents oscillate in a valve (a subject about which I shall have more to say at a later date), but I have had them included at this juncture so that the reader can see for himself how a frequency record can be made. Next week I shall deal with audio frequencies and that controversial subject known as "sidebands."

Moving coil, cone, and dynamic loud-speakers consist of two major parts: the chassis or unit and the baffle. It is a habit with most people to look upon the unit as the complete loud-speaker. This is not so. You can easily prove for yourself by listening to any unit without a baffle, and noticing the complete absence of all low frequencies. This indicates the importance of correctly installing the loud-speaker unit. As a cone diaphragm vibrates it produces alternate compression and decompression of the air, both in front of and in back of the diaphragm; but at any given moment air pressure conditions in front are exactly opposite to those at the back of the cone. On the higher frequencies the area of the cone itself is sufficient to prevent the air from rushing around the edges to equalize the pressure, and thus neutralize sound production; but on low tones, with their slower rate of vibration, the air has time to do exactly that, thus damping out the low-frequency sound vibration. The problem of obtaining good reproduction from a radio set does not end with the purchase of good components, for their proper utilization is just as essential. When a loud-speaker is producing sound the cone attached to the moving coil moves backwards and forwards. If the current flowing in the speech coil has a frequency of

#### WHY THE BAFFLE?

fifty cycles, then every second the cone moves forward fifty times and fifty times backwards. Now every time the cone moves forward it compresses the air in front, and at the same time the air at the back is decompressed, because the cone has moved forward and there is more space at the back for the air to fill. These differences in pressure tend immediately to equalize each other, and the extra air in front begins to run around the edge of the cone to the rear, where there is not sufficient air. Sounds, however, are produced due to the differences in air pressure, and if these pressures succeed in equalizing each other exactly, no sound will be produced. If only partially, there will be only a very little sound. In order to combat this fault it is necessary to provide something which will prevent the air from getting from the front to the back of the cone. This is the reason why a baffle is used. It gives us the opportunity of making the air distance from the front to the back of the cone very much longer. Experiments on these lines, after making calculations of

air pressure and the speed of sound-wave travel, have proved the following sizes of baffle board to be correct. They are calculated from the front edge of the cone to back edge.

Lowest frequency desired.	Length of air path.
30 cycles	9ft.
60 "	4½ft.
100 "	2½ft.
200 "	1½ft.
1000 "	3¼ins.

It should be noticed as an important point in this table that the required length of air path is decreased as the frequency increases. At 1,000 cycles the air path is only 3¼ins., and since the average distance from the centre of the front to the centre of the back of a 10in.-diameter cone is something like 6ins., the cone itself is an effective baffle at high frequencies. No matter what type of baffle is used, or the kind of material of which it is composed, it should be understood that it has only one purpose, and that is to prevent two air pressures from equalizing each other. The baffle material should be such that it will not vibrate under the influence of the movements of the diaphragm, as this would seriously affect the quality of reproduction.

# THE MODERNISATION OF OLD RECEIVERS

By P. E. BARNES, B.Sc. (Hons.).

In this Article the Writer Explains how Out-of-date Receivers can be Improved by the Adoption of a Few Simple Devices

MANY of the readers of this journal must at some time or other, have been asked "just to glance over" an old wireless receiver, usually after the owners have heard a modern efficient set with a high-class moving coil speaker. Some of the earlier sets, which might have represented the last word in radio construction when they were built, are now too out of date to benefit by anything less than complete reconstruction. In some cases, however, in particular with fairly simple two and three-valve loud-speaker sets, which were initially constructed with good quality components, considerable improvements can be effected with very little expenditure of either time or money. Indeed, if much of either were to hand, the construction or purchase of a new set with a good quality loud-speaker would be the more obvious course to pursue.

It is the purpose of this article to show how an old set, fundamentally well designed, may be improved, sometimes out of all recognition, by the adoption of a few simple devices. Most, if not all, of these have been adopted before in various guises, and are occasionally referred to in odd corners of wireless magazines, but the writer cannot call to mind any article published recently which has attempted to collect the important points together, along with the principles on which they are based.

obvious, but it is often advisable to include some decoupling device in the anode lead to the detector valve. It is not generally realised how much distortion can be produced by feed-back effects with modern valves, before "howling," "motor-boating" or other audible indication of the trouble is given. Five or six years ago, all troubles of this nature were attributed to "interaction," and many of the local experts who

duction. This device is, of course, adopted frequently in various forms. It is, however, not so generally realised that a choke coil has exactly the opposite effect to a condenser. The current which passes through a choke coil (if we neglect its resistance, which is low), is proportional to

$$\frac{1}{\text{Inductance} \times \text{Frequency}}$$

Thus, as the frequency gets lower the current which is passed is increased. Both condensers and chokes are seldom variable, in the cases which we are likely to encounter, but a similar effect to a variable condenser or choke can be obtained by connecting a variable high resistance in series. When the resistance is at its least value, which may be short-circuited, then the choke or condenser acts as if it were alone, and its effect can be reduced to any required degree by increasing the resistance.

In a number of cases, neither simple tone raising nor lowering will give the required quality because in the case of the majority of old loud-speakers, the best response was to the middle frequencies, and it was the lack of sufficient real bass (as distinct from spurious resonances), and the reduction of the upper harmonics which made the reproduction sound so flat and uninteresting. Now it is possible to obtain a circuit using both condensers and chokes which will

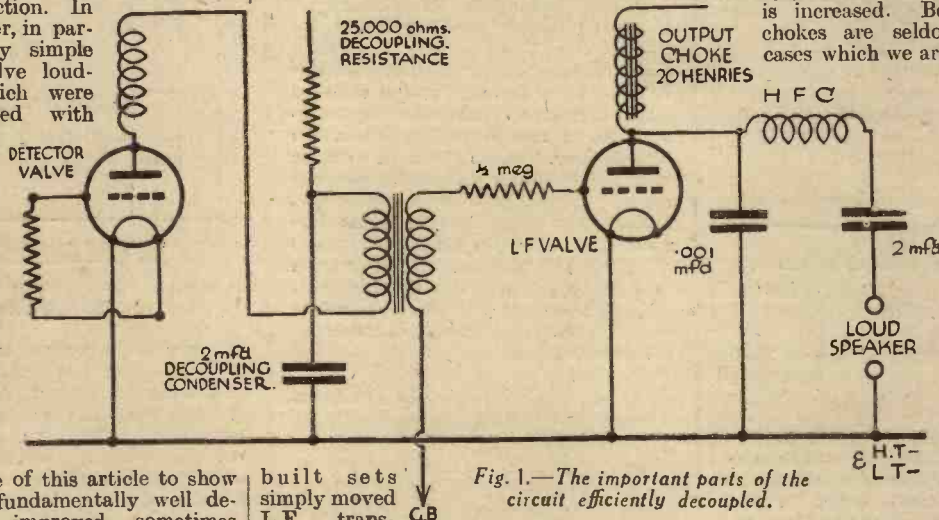

Fig. 1.—The important parts of the circuit efficiently decoupled.

built sets simply moved L.F. transformers away from one another, put in large by-pass condensers wherever possible, and earthed all sorts of things until the noises subsided, and then blamed the transformers for the resultant distortion, not realising the evil effects of battery coupling.

The use of a choke output filter is in itself a very efficient means of decoupling, while the use of an ordinary H.F. choke in the output circuit, with a small condenser from the anode of the output valve to earth, will often have a very beneficial effect on otherwise intractable cases of feed-back.

The use of a small condenser of about .0001 mfd. from the anode to the detector valve to earth is a very common practice, but it is not always realised how the effectiveness of such a device can be increased by the use of a 1/2 megohm grid-leak in the lead to the grid of the first L.F. valve. Usually, after these devices have been tried and if necessary, incorporated, it is required to do something or other to improve the response of a rather indifferent loud speaker, and much more may be done here than is commonly realised.

### Low Frequency Components

First of all let us consider the effect of certain components in the low frequency circuit. A condenser will pass an alternating current which is proportional to the frequency multiplied by the capacity of the condenser. Thus, shunting the output terminals with a condenser will cut down the intensity of the higher frequencies, and give a more mellow tone to the repro-

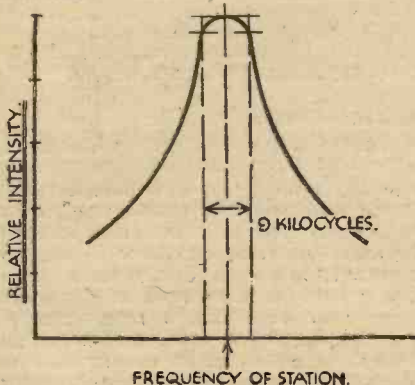

Fig. 2.—Correct tuning—only slight sideband cutting.

### Decoupling Devices

Many old receivers, owned by listeners with no technical knowledge, have been fitted with new valves without the necessary alterations having been made to the grid bias, anode voltage, or other working conditions. The course to adopt here is

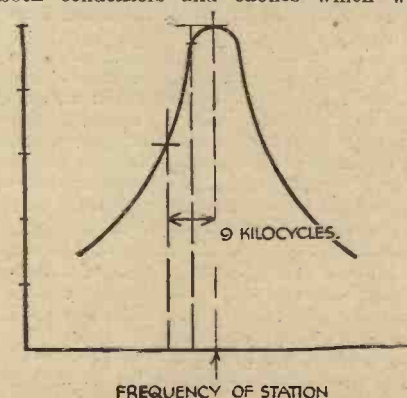

Fig. 3.—Slight detuning—one sideband reduced to half of correct intensity.

duce the middle frequencies, while leaving the upper and lower ones at little less than their former intensity. If a choke and a condenser are placed in series, then the higher frequencies, which can pass the condenser easily, are almost entirely cut off by the

# ANOTHER GREAT FREE GIFT SCHEME

choke, and the frequencies which are passed most easily by the choke, will not pass the condenser in sufficient quantity to affect the result. The middle frequencies of the audible range, however, will not be too drastically reduced by either component, and so they will pass the filter more readily. This gives us then a means of reducing the excessive output of the average old type of speaker (and of some of the newer ones in the middle register). By the use of com-

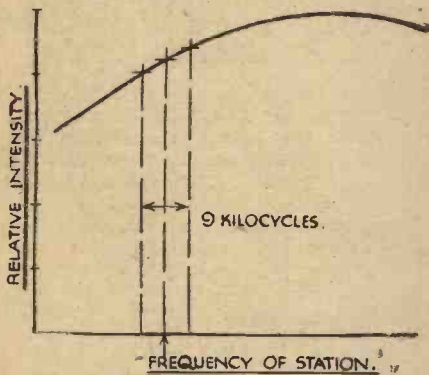

Fig. 4.—Flat tuning circuit gives least distortion on detuning.

ponents of the correct values it is possible to reduce excessive resonance in any part of the musical scale.

## Using a Transformer Winding as a Choke

In order to put these suggestions into practice it is by no means necessary to purchase a special tapped choke. A very satisfactory choke can be made from one winding of a transformer of which the other has been burnt out, or even a very cheap new L.F. transformer can be purchased if it has a winding divided into sections. It is not a very difficult task to take out tapping points from such a transformer, one from each section of the winding. Remember, however, in doing this that the inductance of a choke is proportional to the square of the number of turns, i.e., a centre tapping gives one quarter of the inductance and so on.

It may be objected that all the devices which have been mentioned above are those which tend to reduce the volume output of the set. This is, however, not such a serious matter as it might appear.

The majority of sets to which the above method of treatment is applicable were designed to give reasonable loud-speaker reception from one or two B.B.C. stations. With the far greater efficiency of modern valves, and the higher power of transmitting stations there should be a considerable margin of power in hand, in fact, cases often occur of distortion caused by badly overloaded loud-speakers or output valves, and it should be possible to obtain vastly improved quality and clarity, while still giving signals at least as loud as formerly.

## Volume Controls

In considering the question of volume controls, the use of the variable-mu valve can be neglected, as the majority of earlier receivers would require more than "simple

## The "Practical Wireless" DATA SHEETS A NEW READER SERVICE START COLLECTING NOW!

Again "Practical Wireless" is to the fore! Continuing its practical policy of providing its readers with the latest and most up-to-date information, we this week present to every reader the first of our splendid series of wireless data sheets. This first sheet contains in at-a-glance form all of the essential data necessary to enable the home constructor to charge and maintain his accumulator. It is printed on a serviceable manilla board, specially made to stand up to constant use. Other data sheets will be given free each week until further notice. Each sheet will deal with some special branch of wireless construction or operation, such as coils and coil winding, resistances, mains transformers, chokes, condensers, etc. etc.

## KNOWLEDGE IN A NUTSHELL

This remarkably complete series of data sheets is just what the home constructor has wanted, for they provide a rapid means of surveying the field of wireless construction, operation and adjustment. When you have collected the series you will be able, by a mere flick of the finger, to consult that fact, figure, or formula which formerly you have not easily been able to find. We have been to great trouble to collect the facts and to present them in an easily-consulted form.

## DESIGNED FOR EASY REFERENCE

You will notice that we have had the data sheets specially punched, so that you can file them weekly. If you are a regular reader, you may take advantage of the special offer made on page 643, and obtain the serviceable and attractive binder (cloth bound, stiff boards) in which to keep them.

It is a remarkably generous offer to all who take "Practical Wireless" regularly.

## NO COUPONS TO COLLECT

Make a note of the fact that you have nothing to do to obtain this fine series of data sheets. There are no coupons to collect. The data sheets are included in every issue—one a week until further notice.

## NEXT WEEK'S SHEET

Next week's data sheet will deal with Coils and Coil Winding. See that you collect this valuable series by placing a regular order with your newsagent!

modification" to incorporate them. The practice, once very common amongst non-technical listeners, of detuning in order to reduce the volume of loud signals, may be the cause of quite bad distortion. For perfect reception it is necessary to pick up at the same intensity, signals covering a band of about 9 kilocycles. A receiver which has a very loose aperiodic aerial coupling, a common method of giving selectivity to single tuned sets, will always

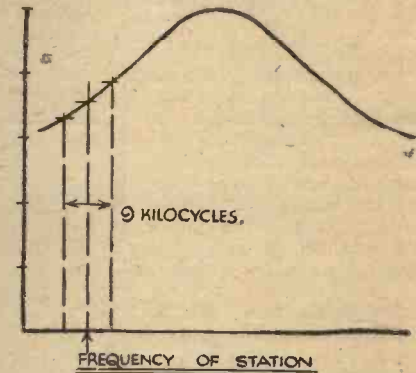

Fig. 5.—Considerable detuning gives less distortion than Fig. 3.

lose a certain proportion of the sidebands, with a resultant reduction in the loudness of the higher musical notes. This in itself is often too slight to be detected without very careful listening. If, however, the receiver is slightly detuned by, say, four-and-a-half kilocycles, then we shall be receiving one sideband very well, the carrier wave not so well, while the other sideband produces very little response, and so "harmonic distortion" will be produced in the receiver. If the de-tuning be carried still further, this effect will become less noticeable, and the quality will improve.

If the set concerned has an H.F. valve, then a measure of volume control may be obtained by means of a rheostat to reduce its filament temperature, while the use of a high resistance potentiometer connected between the aerial and earth terminals, with the moving arm connected to the grid end of the aerial tuning coil, is a simple device applicable to most receivers.

## Resistance Coupled Amplifier

Another form of distortion which is of very common occurrence, but does not seem to be very generally recognised, is the poor reproduction of sudden noises, such as cymbals and pistol shots, not because they are loud, but because the rapid changes in current necessary cannot take place quickly enough. The resistance coupled amplifier is an excellent reproducer of such "transient" sounds, because owing to the absence of inductive circuits, such as chokes, there is little opposition to very rapid rises of current. The effectiveness of the resistance coupled amplifier is, however, largely dependent on the use of a high value for the coupling condenser, and it will be well worth while experimenting with different values of this component, using the largest values which can be incorporated without introducing trouble due to "grid blocking" of the following valve.

# AN ELECTROLYTIC CHARGER FOR A.C.

By ALBERT E. OAKLEY

A FEW weeks ago some short particulars of an electrolytic rectifier appeared in PRACTICAL WIRELESS. So many readers have written asking for more details, that we make no apology for presenting in this article complete particulars of the construction and use of a rectifier of this type.

### Cheap and Easy to Make

It has this great advantage: it is cheap to make, for no transformer or factory-made rectifier is needed, and all the materials can be purchased for a very few shillings. Nor is it costly to run, for the lamp used as resistance can, with the arrangement to be described, still be effectively used for lighting.

We shall require about six feet of planed deal, 6in. wide by  $\frac{1}{2}$ in. thick, and three glass cells  $2\frac{1}{2}$ in. by  $2\frac{1}{2}$ in. high. Rectangular cells of this type are obtainable at most electrical stores. It may not be possible to locate cells of exactly the size given, but that is not very material, and will merely involve a little variation in the dimensions of the case, and possibly the plates. There is nothing very critical about the size of the latter, but the area given should not be greatly varied. At a pinch the homely pickle pot or jam jar may be utilised, but these are less compact, and do not permit so tidy a job. It is worth while, therefore, to take a little trouble to get the rectangular cells. A sheet of lead 6in. square will cut the plates, and leave enough scrap for the connecting strips. Ordinary roofing lead is used, obtainable at any builders' ironmongers.

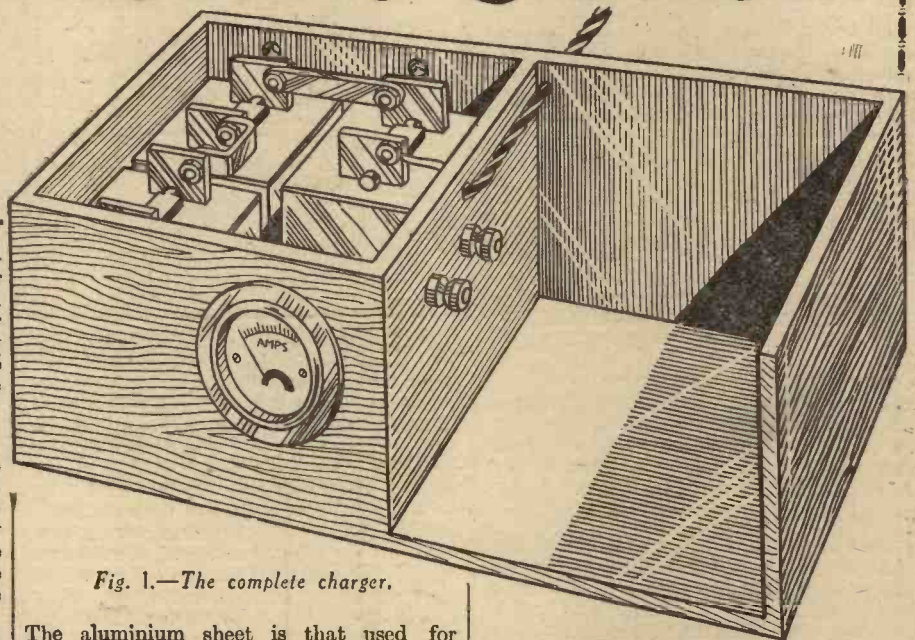

Fig. 1.—The complete charger.

The aluminium sheet is that used for screens, chassis, etc., and may be of No. 20 gauge.

First cut out the plates, as in Fig. 2. Both the lead and aluminium ones are exactly similar in detail. Two  $\frac{3}{16}$ in. holes are drilled on a centre line to receive the spacers, and a  $\frac{1}{2}$ in. hole at the top for the connecting screws. Three covers are needed (Fig. 3), which may be of stout cardboard dipped in hot paraffin wax, but are better cut out of  $\frac{1}{2}$ in. sheet ebonite. There is generally some scrap lying about which will do for small jobs of this sort. The covers are finished  $\frac{1}{8}$ th larger than the tops of the cells, giving  $\frac{1}{16}$ in. overlap. They are slotted for the upper ends of the plates to pass through. This is easily done by first marking out the slot, and then drilling a series of holes, finally cleaning out with a warding file. A  $\frac{1}{2}$ in. hole for ventilation is also drilled. Six spacers are now cut from  $\frac{3}{16}$ in. sheet ebonite (Fig. 2). The ends are shouldered to pass through the holes in the plates.

by the dotted lines, so as to easily slip into the hole in the second plate. It is better to suspend the plates in this manner than to allow them to rest on the bottom of the cell, for both mechanical and electrical reasons. It will be noticed, too, that the plates are not pressed flat against the sides of the cells, but are about  $\frac{1}{4}$ in. away, in order to permit free circulation of the electrolyte.

The cells may now be assembled, as shown in Fig. 3, leaving the connecting strips till last. The containing case will be dimensioned according to the size of the glass cells actually used. It is desirable to allow for  $\frac{3}{16}$ in. slips of wood between cells and sides of box, and  $\frac{1}{4}$ in. slips between the cells themselves, so that air may circulate around them. The base and back are extended to form a compartment in which the accumulators will stand while on charge; this arrangement being much cleaner, tidier and safer than having them standing loose among tools and other gear. The pieces of wood should be screwed together with  $\frac{1}{4}$ in. No. 6 countersunk wood screws. The case is then sandpapered and given two coats of stove or other japan black inside and out. Four  $\frac{1}{2}$ in. holes should be drilled through the back for ventilation, two near the top, and two near the bottom of the box.

An ammeter has been included; this is not entirely necessary, but it is always more satisfactory to have ocular proof that the cells are charging than to merely hope for the best. As the current passing

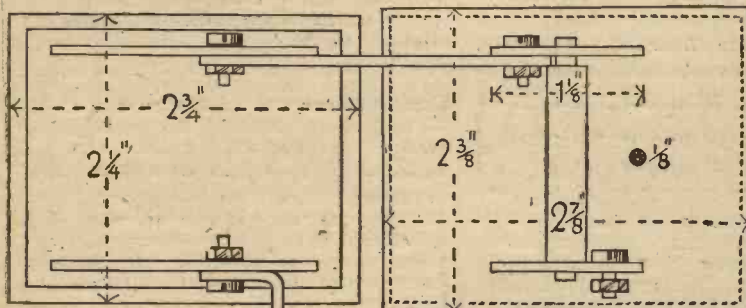

Fig. 3.—The cell assembly.

The bottom spacer holds the plates apart the required distance, and should fit the holes tightly, while the top ones slip in above the cover and serve to suspend the plates. These three will require one shoulder to be cut farther back as shown

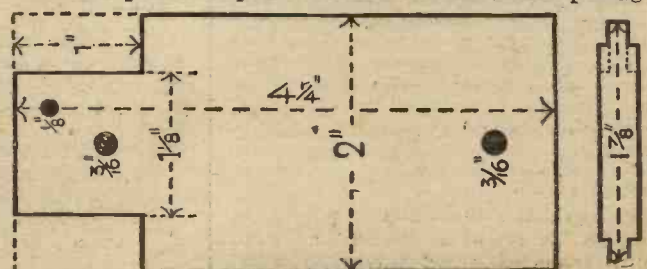

Fig. 2.—Diagram of the plates and ebonite spacers for the plates.

in a trickle-charger is small, the scale of the instrument should be such as will read

convenient and economical to use an existing light point which can still

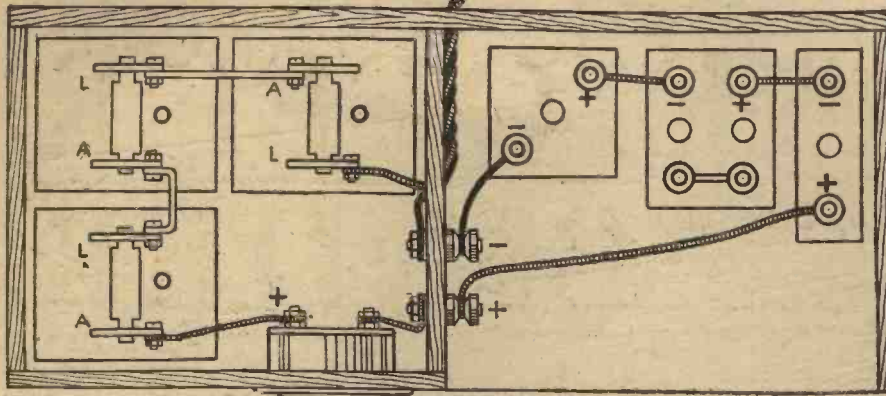

Fig. 4.—Plan view of the assembly.

clearly about .2 of an ampere; so that an ammeter with a full scale reading of about half an ampere will be suitable. It should be of the flush mounting type, with back terminals. A suitable one is made by A. F. Bulgin & Co., list No. D.M.4.

**The Electrolyte**

This consists of commercial ammonium phosphate dissolved in water, and about two ounces per cell is needed. It is best mixed in a separate vessel, and poured into the cells when all the crystals have been dissolved. It is obtainable from any country chemist, but is not stocked by all the London ones (being used agriculturally as a fertiliser), but any chemist will procure it for you. Having filled the cells, the elements complete with covers can be dropped in and connected up as shown in Figs. 3 and 4. Six small brass screws and nuts,  $\frac{1}{16}$  in. long by No. 4 B.A., will serve to attach the lead connectors. Two strong terminals for the charging connections, and a sufficient length of strong braided flex to reach your supply point will complete the apparatus.

**About the Circuit**

Now let us consider the circuit. The diagram Fig. 5 shows the essentials. Current from the mains flows through a resistance lamp to the rectifier, thence to the cells being charged, and back to the other main. The resistance lamp has not been included in the apparatus here described, for the reason that it is more

give a useful light. So the current is taken from one of the house switches either by means of a socket inserted in one of the switch leads as at Fig. 6, or by replacing the switch with

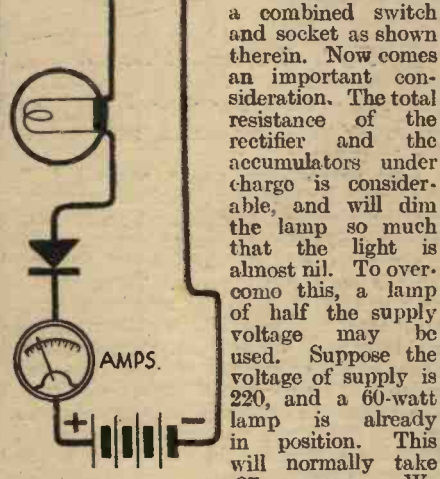

Fig. 5.—Circuit diagram.

a combined switch and socket as shown therein. Now comes an important consideration. The total resistance of the rectifier and the accumulators under charge is considerable, and will dim the lamp so much that the light is almost nil. To overcome this, a lamp of half the supply voltage may be used. Suppose the voltage of supply is 220, and a 60-watt lamp is already in position. This will normally take .27 ampere. We switch on, with the complete charging circuit and accumulators connected; the lamp lights at about half strength. Clearly it is passing no more than half its normal

current, and as we are using virtually half-wave rectification we find on test that the effective D.C. current in the charging circuit is barely .1 amp. This is too little. We can put in a 220 volt 100 watt lamp which will bring the current up to about that required, but our light will still be dim. So we put in a 110 volt 40 watt lamp, which we find is properly illuminated, and gives us the normal charging current of one-fifth to one-quarter of an ampere. As a useful guide, it may be remembered that the effective D.C. current will be about two-thirds of the current actually passing through the lamp. A 60 watt lamp may be used if at any time it is desired to hurry up the charging, but it should be remembered that the rectifying cells warm up slowly in use, and this effect will be increased with the larger current.

**Anticipating Questions**

I will now try to anticipate a few of the questions likely to be asked.

Three rectifying cells give the best results on about 200 volts. Fewer or more cells will reduce the D.C. component.

On 110 volts three cells are still effective, but two only may be used in order to have more voltage available for charging. A

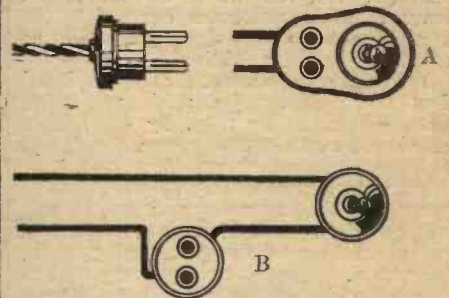

Fig. 6.—Two methods of connecting to the mains.

lamp as low as 32 or 25 volts may be desirable on 110 volt mains if a number of accumulators are to be charged.

It should be remembered that the lower voltage lamp passes more current for the same wattage.

The charging current should not be increased much over the figures given above unless larger cells and plates are used.

**Overloading**

THIS reminds me of another common fallacy. Because the speaker tends to "rattle" when the set is adjusted to give full volume, the owner explains that the speaker "won't stand it," meaning that it is overloaded. In nine cases out of ten it is not the speaker that is overloaded, but the last valve. The simplest way to put things right is to employ a larger high tension voltage and to increase grid bias. It is just like trying to put a quart into a pint pot to expect a large volume of good reproduction from a power valve fed with only, say, 80 volts high tension—it can't be done. If the valve is still overloaded after increasing H.T. to maximum, the power valve must be replaced by a larger one.

**Germany's Licence Figures**

A REPORT just issued by the German broadcasting authorities shows a drop in licence figures over the past three

**Round the World of Wireless**

(Continued from page 632)

months. This is the first time that the figures for the quarter ending in October have been smaller than those for the summer quarter. We hope this does not portend a decline in popularity of German broadcast programmes.

**D.C. to A.C. Conversion**

A FEW weeks ago we mentioned in these notes that when changing from D.C. to A.C. electric supply companies were obliged to bear the cost of conversion of electrical machinery (including radio receivers). Apparently the Fleetwood Council do not agree with this for, despite the protests of 3,000 of its listeners, they contend that they are not legally compelled to bear the cost of altering sets for the new supply. On the other hand the Electricity

Commissioners uphold the view that the Council are responsible. To settle the dispute a "shilling fund" is being organised by the listeners to fight the case in Court.

**Screening H.F. Chokes**

IF your set requires two or more H.F. chokes it is best to choose different types so as to minimise unwanted reaction effects. But it also helps still more if at least one choke is screened by enclosing it in an aluminium or copper can. When this is done care should be taken to ensure that the windings do not come within half an inch or so of the screen at any point because if they do the inductance of the choke will be considerably reduced, and that will result in the choke becoming much less effective. Remember also that the screen must be earth connected if it is going to serve any useful purpose. The screen will, in any case, cause a certain reduction in the choke's inductance and so should only be applied to a choke which is of a high inductance pattern.



# FOR REGULAR READERS ONLY

# SPECIAL OFFER

---

## "PRACTICAL WIRELESS" DATA SHEETS

# BINDER

---

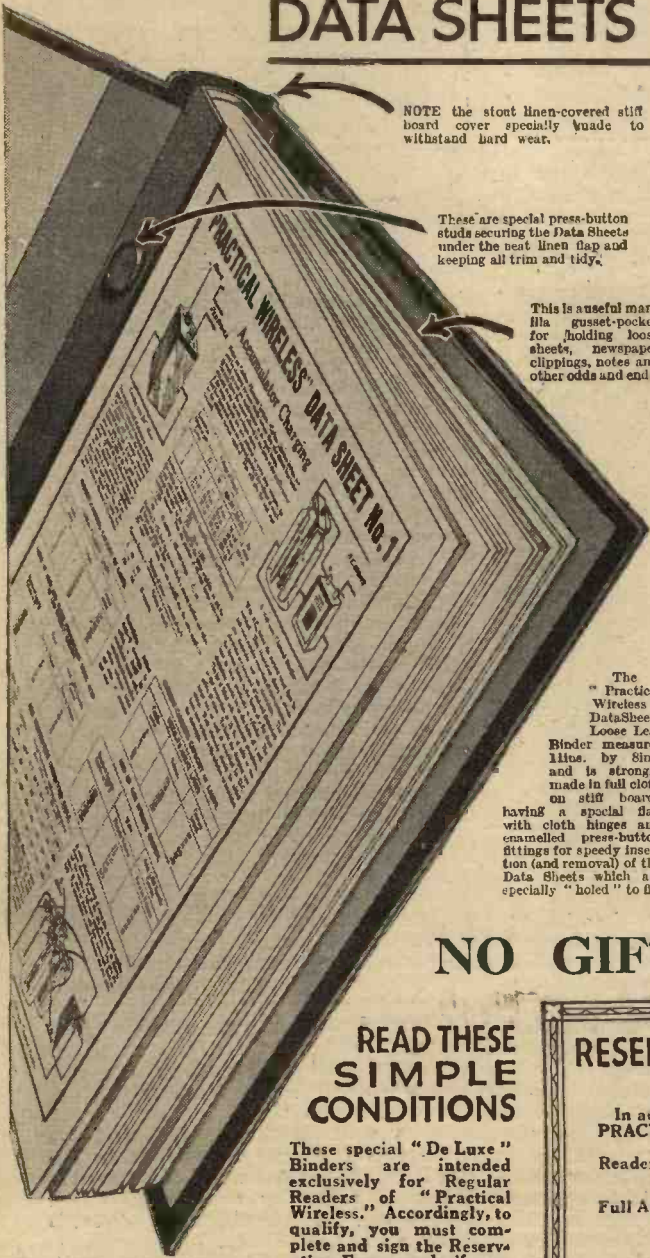

NOTE the stout linen-covered stiff board cover specially made to withstand hard wear.

These are special press-button studs securing the Data Sheets under the neat linen flap and keeping all trim and tidy.

This is a useful manilla gusset-pocket for holding loose sheets, newspaper clippings, notes and other odds and ends.

The "Practical Wireless" Data Sheets Loose Leaf Binder measures 11ins. by 8ins. and is strongly made in full cloth on stiff boards having a special flap with cloth hinges and enamelled press-button fittings for speedy insertion (and removal) of the Data Sheets which are specially "holed" to fit.

Handsome—Handy—Serviceable—  
Permanent, yet always up-to-date.

EVERY reader of "Practical Wireless" will welcome this opportunity to obtain one of these most useful "De Luxe" Binders for preserving the Data Sheets which are being given every week. These Binders are being expressly made for the purpose and will undoubtedly prove most acceptable and helpful to Radio constructors.

The only way to secure your "Practical Wireless" Data Sheets Binder is to fill in and post the Reservation Form at once. As you will see from the conditions below, there are no Gift Stamps to collect. If you are a Regular Reader of "Practical Wireless" you are eligible for a Binder provided, of course, you comply with the simple conditions. Your Reservation Form must reach us not later than December 31st—better fill it in and post to-day.

**N.B.** The date on which the Binders will be ready for despatch will be notified in "Practical Wireless" early in the New Year.

## NO GIFT STAMPS TO COLLECT

### READ THESE SIMPLE CONDITIONS

These special "De Luxe" Binders are intended exclusively for Regular Readers of "Practical Wireless." Accordingly, to qualify, you must complete and sign the Reservation Form, and, if you have not already done so, give your Newsagent an order to deliver (or reserve) a copy every week. Address coupon (i.d. stamp if unsealed) to PRACTICAL WIRELESS Presentation Dept., 39, King St., Covent Garden, London, W.C.2. When your Reservation Form is received, and directly supplies of Binders are available, readers will be notified by an announcement in "Practical Wireless," and each applicant will then be required to forward a postal order for 1/6 to include registration, postage, packing, insurance, etc. Immediately on receipt of this, your Binder will be despatched.

### RESERVATION FORM for P.W. DATA SHEETS BINDER

*No acknowledgment of this form will be sent*

In accordance with the conditions of your special offer, please reserve for me one PRACTICAL WIRELESS, Data Sheet Binder.

Reader's Name .....

Full Address .....

The Newsagent who supplies me weekly with PRACTICAL WIRELESS is:—

Name .....

Address .....

Leave blank

Reader's Signature' ..... No.

Post to PRACTICAL WIRELESS, Presentation Department, 39, King Street, Covent Garden, London, W.C.2, in unsealed envelope (i.d. stamp only).

# Receivers and their Records

We shall be glad to advise readers regarding purchase of complete sets.

REALIZING that in the British Isles there are thousands of listeners who, deprived of the possibility of using an all-mains electric receiver, are desirous of acquiring something better than the average set, H.M.V., in their first battery model, have placed on the market a super-het portable of an advanced design. It might be termed revolutionary, inasmuch as their engineers have produced a complete six-valve superheterodyne receiver, with batteries, frame aeri-als, and loud-speaker all contained in a compact walnut cabinet no larger than the average type of portable or semi-portable set, and yet with an H.T. current consumption not exceeding 11 milliamps! It is this latter point in particular which must be stressed, for up to the present the feed required by a six-valve receiver has usually proved a heavy drain on H.T. batteries and, consequently, condemned them as expensive luxuries to maintain. Moreover, in the model under review, no grid-bias battery is needed, the passage of the high-tension current through suitable resistances giving the necessary bias for the various valves.

In the low-tension current, the circuit is also economical, as the accumulator is only called upon to supply 0.65 ampere.

Starting with the cabinet, of simple but effective design carried out in walnut, we may stamp it as of the usual H.M.V. standard of craftsmanship. Although strongly built, the entire receiver, ready for use, weighs only 34lbs., and it can be carried easily from room to room by means of a "pakawa" handle let into the top of the cabinet.

The entire unit may be slid out of the back simply by the turning of four fixing screws; it is not necessary to remove the control-knobs. In this way, all components are readily accessible on the chassis; the

## H.M.V. Superhet Portable Six

valves are supported in a single row at the back of the receiver, thus making it a simple job to replace them in case of emergency.

Two frame aeri-als are used; they are of

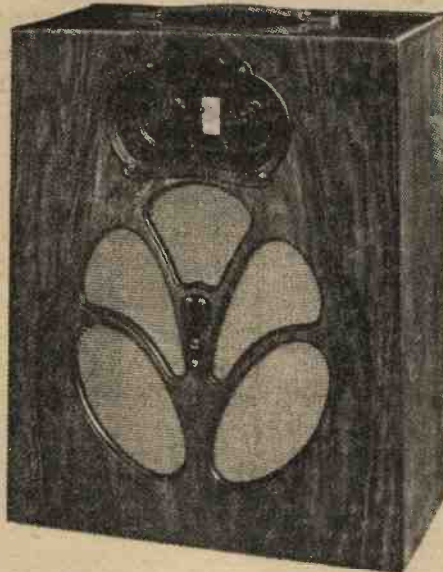

The attractive lines of the H.M.V. Super-Het Portable.

somewhat smaller dimensions than habitually adopted, and are wound on separate formers, the one around the lower portion (loud-speaker frame) of the cabinet being for medium waves, the other wound around the lower half of the hinged back of the cabinet and connected in series, being brought into action for "long" wave operation. The two separate frames, together with the tuned anode circuit coils associated with the first high-frequency valve and the oscillator coils, are tuned by a three-gang condenser. To ensure that the oscillator circuit, driven by a metallized HL2 valve, shall be everywhere tuned to 125 kilocycles above the frequency of the other two circuits, the capacity of each gang, in each receiver, is accurately checked. The frame aerial is tuned by one section of this condenser, and fine tuning, to bring it into exact resonance with the other

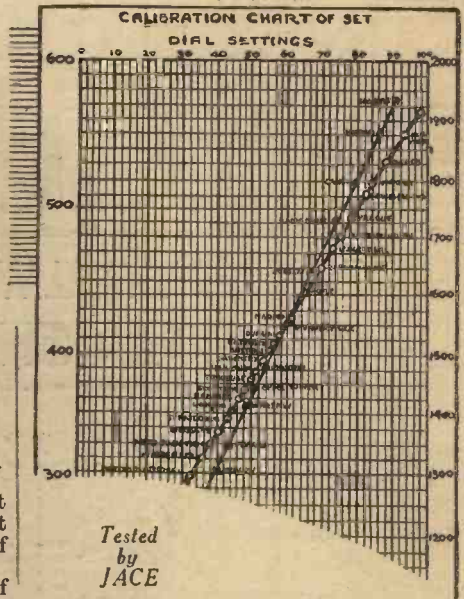

Tested by JACE

circuits, is obtained by means of an adjustable trimmer incorporated in the main tuning-ring.

The first stage of high-frequency is a Marconi metallized (S21) screened-grid valve, the output of which is brought together with that of the oscillator (HL2 metallized) to the grid circuit of the first detector, another S21 valve. Again, the output is applied via an accurately-tuned band-pass unit to the intermediate frequency amplifier (S21), the anode of which is coupled, via a third resonant circuit, to the second detector, a metallized HL2 working on the leaky-grid principle. This detector is transformer-coupled (7/1 step up ratio) to the output pentode valve (PT2) in the anode circuit in which the loud-speaker is connected. Tone correction has been obtained by means of a parallel condenser. Volume control has been secured by employing a potentiometer common to the grid circuits of both the first H.F. and first detector valves, its function being to vary the bias in both cases.

Although primarily built for use with a 120-volt dry battery, the instrument is completely decoupled; if a mains unit is adopted to supply the H.T. current, the receiver will be free from hum and perfectly stable. In the case of battery feed, the automatic biasing arrangement incorporated in the circuit provides semi-automatic compensation for any drop of voltage. The high-tension current to all valves is taken through a single connection from the battery, the bias being obtained across definite portions of the potentiometer in the circuit. By this means, as the battery loses its potential through age, and the anode voltage to the valves falls, so the bias is automatically lowered in proportion and quality remains constant, although volume may be reduced, throughout the useful life of the battery.

In this receiver, tuning has been simplified to the utmost degree. There are only two main controls on the front of the cabinet. The one on the left consists of a knob operating the "on" and "off" and wave-change switch, surrounded by an outer ring by which signals can be increased in volume to the extent desired. Its "opposite number" on the right controls the gang-condenser, connected to a clearly-marked dial calibrated in wave-

(Continued on page 656.)

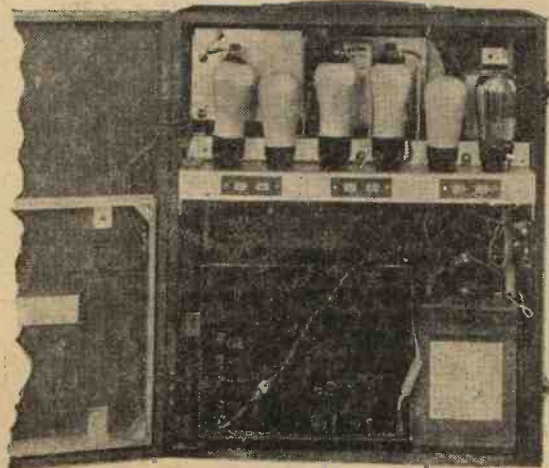

The neat arrangement of the internal parts of the H.M.V. Portable.



**"The set seemed to jump to life"**

FROM all over the country we are receiving letters like the one here reproduced—sure proof that Cossor Screened Grid Valves definitely give improved performance. Why put up with indifferent radio? Why continue to deprive yourself of the full capabilities of your Receiver? Widen your choice of programmes—bring in those stations which, now, are merely whispers—equip your Set with Cossor, Britain's most efficient Screened Grid Valves.



—user's striking tribute to the efficiency of Cossor S.G. Valves

Liverpool

Dear Sirs,

Three weeks ago at a very interesting part of a broadcast, my screened grid valve went out of action. I went to a wireless shop for the same make I had been using (foreign) but they had none in stock. They advised me to try Cossor so I purchased one. I put in the metalised S.G. valve and when I switched on I got a surprise.

The set seemed to jump to life. I heard instruments that I had never heard before and the artists sounded as if they were in the next room. Even the loud speaker sounds 100% better and foreign stations come in much clearer.

All my friends agree that the Cossor S.G. valve has improved my reception. In conclusion I might say that I intend replacing all the valves with Cossor.

Yours faithfully,

Sgd. \_\_\_\_\_

# COSSOR SCREENED GRID VALVES

Send for a free copy of the 40-page Cossor Valve and Wireless Book which contains a wealth of interesting and useful information including Radio Definitions—Useful Circuits—List of Stations, etc., etc. Please use the Coupon.

To A. C. COSSOR LTD., Melody Department, Highbury Grove, London, N.5.  
Please send me, free of charge, a copy of the 40-page Cossor Valve and Wireless Book B.17.

Name \_\_\_\_\_

Address \_\_\_\_\_

My usual Retailer is \_\_\_\_\_

Address \_\_\_\_\_

The original of the testimonial above reproduced may be inspected at our Head Office, Cossor House, Highbury Grove, London, N.5.

A. C. COSSOR LTD., Highbury Grove, London, N.5. Depots at Birmingham, Bristol, Glasgow, Leeds, Liverpool, Manchester, Newcastle, Sheffield, Belfast, Cardiff and Dublin.

2087

**THE HALF-GUINEA PAGE**

# Radio Wrinkles FROM READERS

**To Finish Coil Windings**

THE following method of securing the ends of the windings of single-layer coils will make a neat job, and will effectively prevent the end turns from slipping off the former. Before starting to wind the coil, cut a piece of narrow adhesive plaster about 1in. longer than the coil-former. Lay this on the former, sticky side upwards, leaving  $\frac{1}{2}$ in. projecting over each end of the former. Wind the first few turns over the plaster, and then turn the loose end over the top

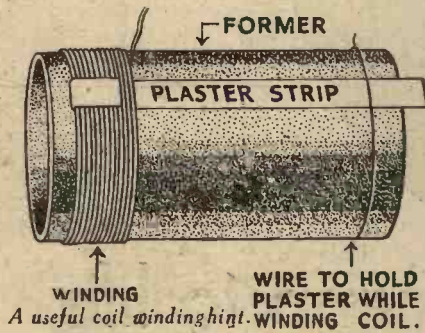

of them, thus binding them securely together. When you come to the end of the winding, stick the other end of the plaster over the final turns in the same way. If the winding is a long one, the free end of the plaster will tend to come away from the former and impede you as you wind. To prevent this, twist a piece of wire round the former temporarily, to keep the plaster in place, removing it when you get near the end of the winding.—A. V. D. H. (Wembley).

**Fixing Control Knobs**

ONE of the minor annoyances of radio is the knack that the knobs of the volume control and reaction condensers, etc., have of working loose. The accompanying sketches show how I overcame this trouble on my set. Remove the knob, and file a small flat on the spindle in the place where the grub screw of the knob makes contact, taking care to file only enough away that will allow the screw an extra turn or two. Having done this satisfactorily, refit the knob and tighten up the screw. Then melt a little cobbler's heelball into the screw hole of the knob and force it well down on to the head of the screw. When this is set you will find it is impossible to make the knob slip, even if you purposely try to force it. Should you at any time want to remove the knob again, heat an old screwdriver, and press it into the screwhole, turning it slowly until it drops into the head of the screw.—HERBERT E. KUSSELBEE (London, S.W.).

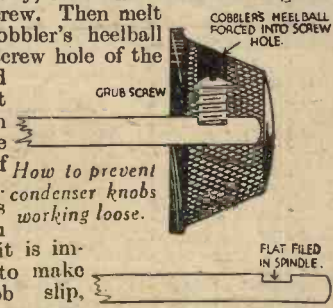

**THAT DODGE OF YOURS!**

Every reader of "PRACTICAL WIRELESS" must have originated some little dodge which would interest other readers. Why not pass it on to us? For every item published on this page we will pay half a guinea. The latest batch is published below. Turn that idea of yours to account by sending it in to us, addressed to the Editor, "PRACTICAL WIRELESS," George Newnes, Ltd., 8-11, Southampton Street, Strand, W.C.2. Put your name and address on every item. Please note that every notion sent in must be original. Mark envelopes "Radio Wrinkles."

**Switching a Reaction Condenser**

THE following is a simple dodge which I have used with success, to obtain adequate reaction on the long-wave section of a dual-range coil. When the wave-change switch plunger is pushed in, it is arranged to switch a .0003 fixed condenser in parallel with the reaction condenser, as shown in the sketch. When the switch knob is pulled out, the two brass strips are arranged to spring apart, about  $\frac{1}{8}$ in., thus cutting out the fixed condenser.—F. GREEN (Bramley).

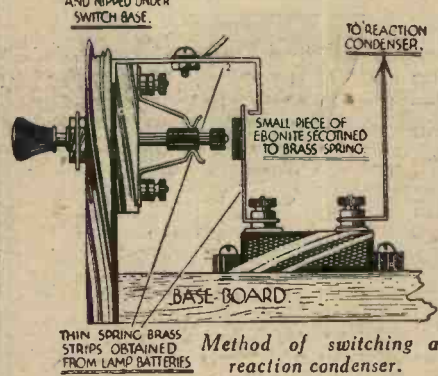

**A Useful Panel Cutter**

THIS tool is of an adjustable type, and is made from a piece of  $\frac{1}{4}$ in. diameter steel, as shown in sketch. It is drilled up the shank to take a  $\frac{1}{4}$ in. diameter grub screw, which acts as both a "pilot" for the cutter, and a lock for the adjustable cutter, which runs at right-angles to the shank. The cutter is made from a short piece of  $\frac{1}{4}$ in. diameter silver steel, bent over at right-angles, and ground to a cutting edge, the latter being tempered. A flat filed on the underside of the cutter prevents it from turning when in use. The main use for this tool is cutting odd-sized holes in ebonite panels.—C. CROWLEY (Birmingham).

**Energising Moving-coil Loud-speaker Fields**  
A CHEAP method of energising high resistance moving-coil loud-speaker fields from A.C. mains is as follows. The scheme is applicable in the cases of moving-coil loud-speakers having field coils of

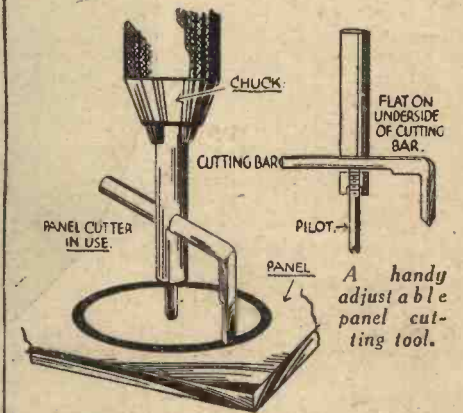

resistances of the order of 6,000/7,000 ohms, and is suitable where A.C. mains of 200/250 volts are available. It consists of using an old 6-volt power valve, or super power valve (one which has been discarded for its normal purpose) as a single-wave rectifier supplied with H.T. direct from the mains. Its filament is heated by a cheap bell transformer, which can be obtained for three or four shillings. A 4 mfd. condenser is the only other component required—besides, of course, a valve-holder. The grid and plate terminals of the valve-holder are connected together to form the anode terminal of the rectifier, which is joined to one side of the mains. The positive terminal of the rectifier is, of course, either of the filament terminals of the valve, and is connected to one side of the field winding, the other side of which is connected to the remaining mains terminal. The 4 mfd. condenser is connected across the field winding, and the primary of the bell transformer is connected across the mains. The connections are shown diagrammatically in the accompanying sketch. The writer has had a unit of this kind in use for the past year for supplying a moving-coil speaker, and it has proved very satisfactory. The field winding is receiving about 30 m.a. at 185 volts from 200-volt mains. The valve is a very old Marconi D.E.5a, the filament of which is connected to the 5-volt winding of the bell transformer.—H. N. GLEDHILL (Leeds)

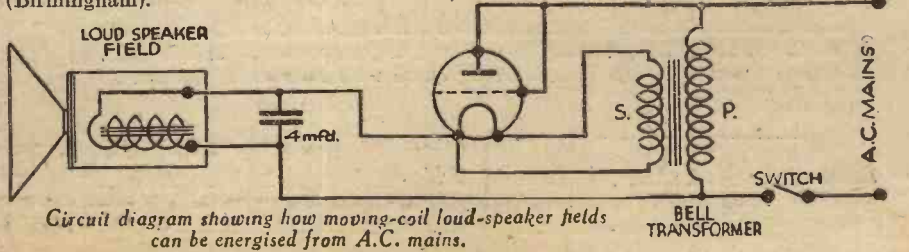

# TELSEN L.F. TRANSFORMERS COUPLING UNITS and OUTPUT CHOKES

## TELSEN "ACE" L.F. TRANSFORMER

The Telsen "Ace" is eminently suitable for Receivers where highest efficiency is required at low cost and where space is limited. Its characteristic curve bears comparison with that of the most costly transformers  
Ratio 3-1 **5/6**  
Ratio 5-1

## TELSEN "RADIOGRAND" (Ratio 1.75-1) TRANSFORMER

For use in high-class receivers employing two stages of L.F. amplification. When used following an L.F. stage employing choke or resistance coupling, it gives ample volume with remarkable reproduction. **10/6**

## TELSEN "RADIOGRAND" (Ratio 7-1) TRANSFORMER

Gives extra high amplification on receivers employing only one stage of L.F. amplification. Not recommended for use with two L.F. stages, as overloading is likely to occur. **10/6**

## TELSEN 1-1 INTERVALVE COUPLING UNIT

A modern development of the R.C. unit, incorporating a low pass filter feed in its anode circuit, thus preventing instability due to common couplings in eliminator and battery circuits. Used with an H.L. type valve it gives an amplification of about 20 and a perfect frequency response on a negligible consumption of H.T. current. Its remarkable "straight line" characteristic curve places it in the forefront of all components of its type. **7/6**

## TELSEN INTERVALVE L.F. COUPLING CHOKES

Primarily designed for use as coupling chokes but may be used in any circuit carrying not more than the stipulated maximum current. The 100H type is for H. or H.L. type valves and the 40H for L. types.  
Normal Max.  
Rating Current Current  
40H—5 m.a. 10 m.a. **5/-**  
100H—3 m.a. 8 m.a.

## TELSEN TAPPED PENTODE OUTPUT CHOKO

For mains and battery operated pentodes taking an anode current of up to 20 m.a. The single tapping provides (by reversing) ratios of 1-1, 1.6-1, 2.5-1, ensuring perfect matching under widely varying conditions. Also suitable for matching a low impedance speaker with an ordinary power valve, a 1 mfd. coupling condenser being recommended for this purpose. **7/6**

## TELSEN OUTPUT CHOKO

Designed for use with power or super-power valves taking an anode current of up to 40 m.a., this output filter provides an ideal response curve under all conditions. For use with a condenser of not less than 1 mfd. capacity. **7/-**

## TELSEN POWER PENTODE OUTPUT CHOKO

For mains operated pentodes taking an anode current of up to 40 m.a. Serves both to prevent direct current passing through the speaker and to match the speaker to the pentode valve, with the choice of three ratios—1-1, 1.3-1, 1.7-1. Used with a 1 mfd. condenser it gives a great increase both in quality and volume. **10/6**

## TELSEN MULTI-RATIO OUTPUT TRANSFORMER

For use with moving-coil speakers, having a low impedance speech coil winding, and suitable for anode currents of up to 40 m.a. Three ratios—9-1, 15-1, 22.5-1—allow for correct matching of speakers of widely varying characteristics. **10/6**

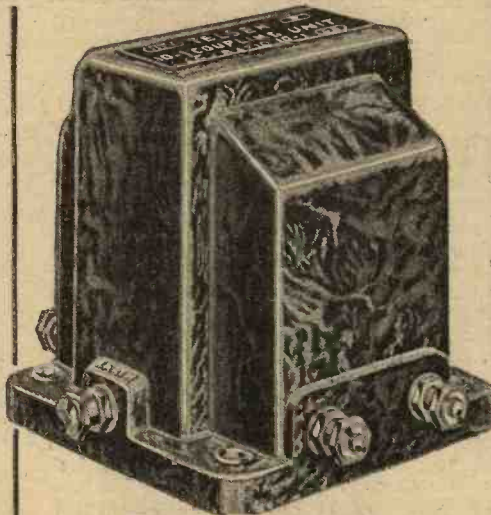

## TELSEN RADIOGRAND (Ratio 5-1) L.F. TRANSFORMER

Telsen Radiogrand Transformers have signified to expert designer and enthusiastic constructor alike all that is finest in British Radio craftsmanship. They are designed in accordance with recent research, constructed on the soundest engineering principles and tested rigorously under broadcast conditions for immaculate performance and enduring efficiency. The excellence of the characteristic curve is only the logical result of this insistence on perfection, revealing the fact that they give a performance equal to that of the highest priced transformers: Ratio 3-1 Ratio 5-1 **7/6**

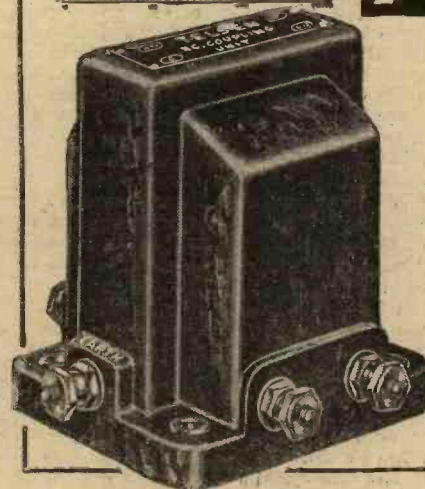
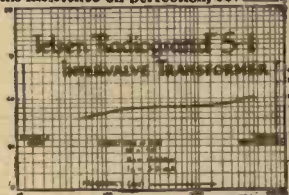

## TELSEN OUTPUT TRANSFORMER (Ratio 1-1)

For connecting the speaker to the output stage, using a triode valve. Avoids saturation by isolating the D.C. from the speaker windings. Also keeps H.T. voltage from the speaker and its lead, which is specially important where a D.C. eliminator is being used. Suitable for anode currents of up to 40 m.a. **10/6**

TELSEN 10-1 INTERVALVE COUPLING UNIT  
A filter-fed transformer using a high permeability nickel alloy core, securing a 10-1 voltage step-up while preserving an exceptionally good frequency characteristic. The response is compensated in the higher frequencies for use with a pentode valve giving an amplification greater than anything previously achieved, equal to two ordinary L.F. stages but with better quality of reproduction. **12/6**

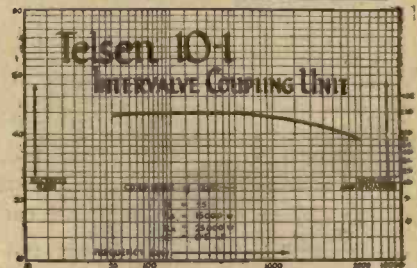

## TELSEN R.C. COUPLING UNIT.

A complete assembly in a compact and convenient form for effecting Resistance Capacity Coupling in the L.F. stages of a receiver, conforming in design to the Telsen L.F. Transformers and Chokes. The Unit incorporates a 50,000 ohms wire wound anode feed resistance and a .01 mfd. coupling condenser. For best results it should be preceded by an H.L. type of valve having an impedance of approximately between 10,000 and 30,000 ohms, and be connected to an H.T. supply of not less than 80 volts. **4/-**

# TELSEN

RADIO COMPONENTS

**TELSEN RADIO COMPONENTS ARE 100% BRITISH**  
ANNOUNCEMENT OF THE TELSEN ELECTRIC CO., LTD., ASTON, BIRMINGHAM

**Radio Wrinkles**

(Continued from page 645.)

**Selectivity Unit and Stand-by Crystal Set**

THE enclosed idea may appeal to those readers interested in experimenting with regard to selectivity. The circuit is self-explanatory. Briefly, it is made up as follows: A small ebonite panel is used to which is fixed one switch arm, five contact studs, one .0005 mfd. variable condenser, and one crystal detector. To a small base-board, fix one .0003 mfd. fixed condenser, one pre-set or semi-variable condenser,

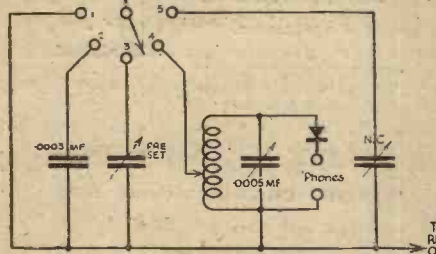

Circuit diagram of a useful selectivity unit.

one neutralizing type condenser, and a coil suitable for covering the lower broadcast wave-band. A telephone jack can be mounted on the panel or terminals on the baseboard, and two sockets, one on either side of the panel, complete the construction. In use, the unit can be placed between the aerial and an existing receiver, and by using the studs a varying degree of selectivity may be obtained. Stud 4 brings a wave-trap into circuit, and by removing the connection from the unit, from the "A" terminal of the receiver to the "E" terminal, and inserting a pair of 'phones into the circuit, a stand-by crystal set is brought in. Stud No. 5 will be found very useful when it is desired to eliminate dead spots, when tuning a short-wave receiver. This idea has been used by the writer for some time, when experimenting with various types of receivers of doubtful selectivity.—E. CHOLOT (Hounslow).

**Earth Wire Attachment**

I HAVE used the gadget, shown in the accompanying sketch, for about two years, and it makes a very efficient earthing system. The clip consists of a strip of copper fins, by  $\frac{1}{16}$  in. by  $\frac{1}{8}$  in. thick, one end being bent round the water pipe and clamped with a nut and bolt, after the pipe was cleaned with emery paper and smeared with vaseline. The end of the earth wire is threaded through holes in the other end of the copper strip, and soldered at different points, as shown in the sketch.—W. GREGORY (Ac-crington).

An efficient earth-wire attachment.

**Charging Wireless Accumulator from a Car Battery**

MANY readers will have their cars and motor-cycles laid up for the winter months, and are wondering what to do with their lighting batteries. They should either be laid up according to the makers' instructions, or made to "work." Readers with 2-volt wireless cells can "work" their lighting batteries by trickle-charging their radio 2-volt cells. The gear required is an ammeter and a regulating resistance (6-12 ohms, preferably) which should be wound on porcelain or other fireproof material—as the resistance heats up. Connect the batteries as shown in the sketch, and vary the resistance until about .25 amp. is registered. Give the ammeter a periodical inspection and, if the current charge has dropped below its former value, get the lighting battery charged up again. Those readers who are continuing motoring are more fortunate, for they can charge their radio cell for nothing. This is handy for readers who live in the country and have some distance to go to a charging station. Most car batteries suffer from over charging, since the advent of the motor-car dynamo. Therefore, a little extra work won't do any damage. It would be very convenient to have two terminals outside the battery, so that you could charge your cell up with the lighting battery in situ. Connect as shown.—N. W. GRIFFITHS (Durham).

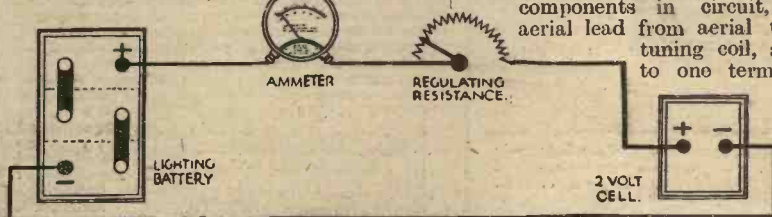

Charging a wireless accumulator from a car battery.

**Locking Device for Cabinet**

BEING the possessor of a popular type of radio cabinet (with lifting lid), and also a small son whose one delight seems to be dropping bits of wire, etc., "into the works" of my set, I was forced to find some means to foil the youngster in his tricks. The result is a very fool-proof lock. The metal strip is made of stout tinplate, or an annealed hacksaw blade (with teeth filed off), and bent to shape. This is attached to right-hand side of cabinet a short distance below the lifting edge of the lid, as shown in sketch. A round-head screw is screwed into the underside of lid in such a way that when the lid is closed, it pushes the spring to one side, and the spring slips over the screw head on to the flat of the screw and automatically locks. To unlock, it is only necessary to have a short piece of stiff wire. The end is pushed into the key-hole, so that the hook engages with the spring. Upon giving this a tug the spring disengages and the lid may be lifted.—J. E. HUGHES (Gronant).

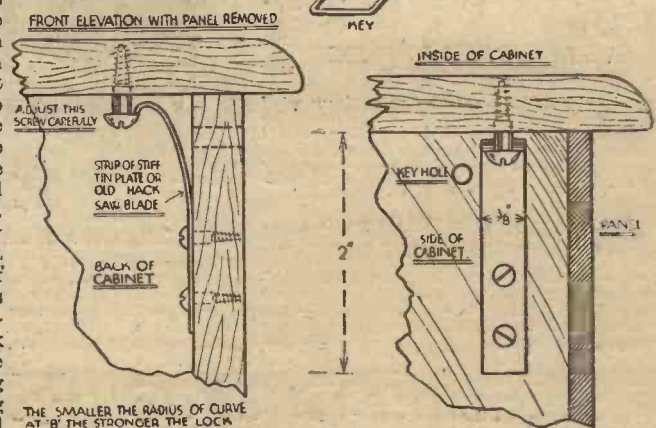

A concealed locking device for a radio cabinet.

**Increasing Signal Strength**

THE accompanying sketch shows a good method for bringing in weak signals on the long-wave band to good speaker strength. I myself use it on a band-pass set, and am greatly pleased

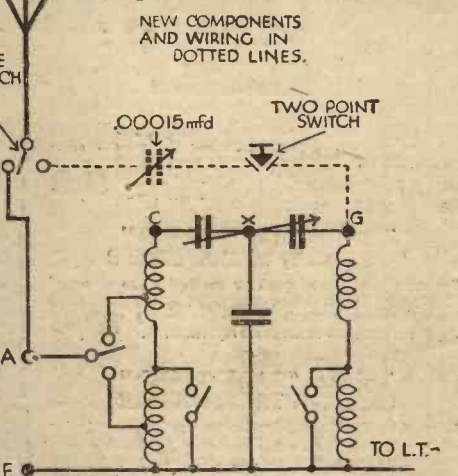

A simple method of increasing signal strength.

with the result. The components required are as follows: one change-over switch, one two-point switch, and one variable condenser (.00015 mfd.). To connect the components in circuit, disconnect aerial lead from aerial terminal on tuning coil, and connect to one terminal on the change-over switch (the terminal which is shorted to switch plunger). Next, connect a lead from terminal (one which makes a circuit when switch plunger is pushed in) to aerial terminal on tuning coil, and from the remaining terminal of change-over switch take a lead to the moving vanes terminal of the .00015 condenser. From the fixed vanes terminal of condenser take a lead to one terminal of two-point switch, and from the remaining terminal of two-point switch connect a lead to grid terminal of tuning coil.—G. H. LEECH (North Ormesby).

# A NEW SET FOR XMAS

—for a few shillings

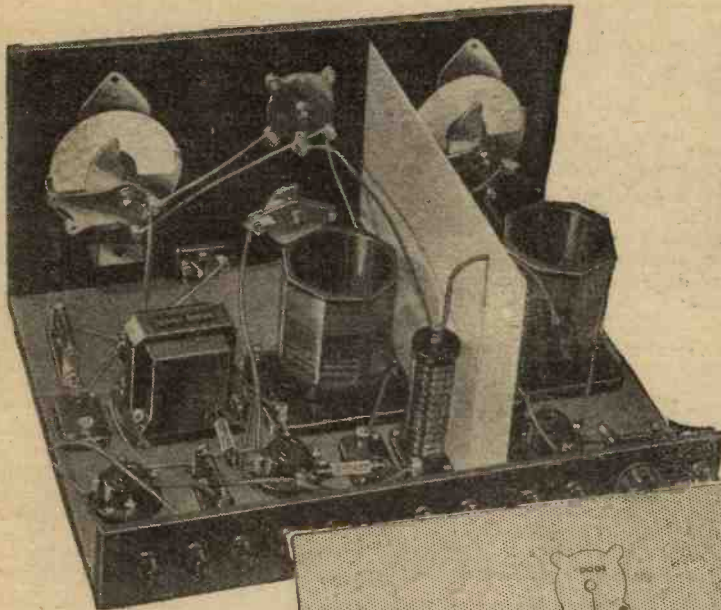

10 sets to choose from

Full instructions are contained in the Kendall-Price Book which tells you how you can easily convert your existing set and contains all necessary details should you wish to build any of the ten famous modern sets described.

The Kendall-Price S.G.4, illustrated here, a new highly efficient circuit which will give you a wide range of home and Continental Stations at great volume as well as Short Wave Stations from all parts of the World. If your set is a 3 or 4-valver the conversion will cost you only a few shillings.

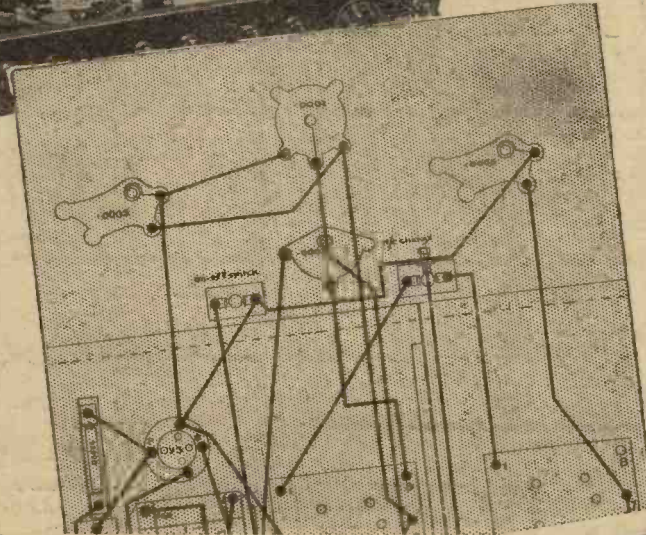

## FREE

Ask your radio dealer or post coupon now and we will send you the Kendall-Price 36-page 1s. Book FREE. It contains complete instructions, photographs and diagrams of ten modern circuits, both battery and mains operated and is invaluable to every constructor.

Other sets described are:—

- Kendall-Price 2
- Kendall-Price 3
- Kendall-Price All-Wave 3
- Kendall-Price S.G.3
- Kendall-Price A.C., S.G.3
- Kendall-Price Short Wave 2
- Kendall-Price Short Wave Adaptor
- Kendall-Price A.C. Power Unit
- Kendall-Price D.C. Power Unit

# READY RADIO



To: **READY RADIO LTD.** (Book Dept.), Eastnor House, Blackheath, S.E.3  
 Please send me the 1s. Kendall-Price Book of ten circuits —FREE. I enclose 1½d. stamp for postage.

Name .....

Address .....

If you also require the ten full-size blueprints enclose 1s. in stamps with this coupon. [Frac. W. 11.]

## FULL SIZE BLUEPRINTS

Full-size dimensioned blueprints for the ten Prize Circuits are also available at the exceptionally low price of 1s. for the set of ten. If you require these blueprints enclose 1s. in stamps with coupon.

# THE MIDGET TWO

An Amazing Complete Two-valve Set which Measures only 4 in. cube. Operated by Dry Cells. A Real Ec-

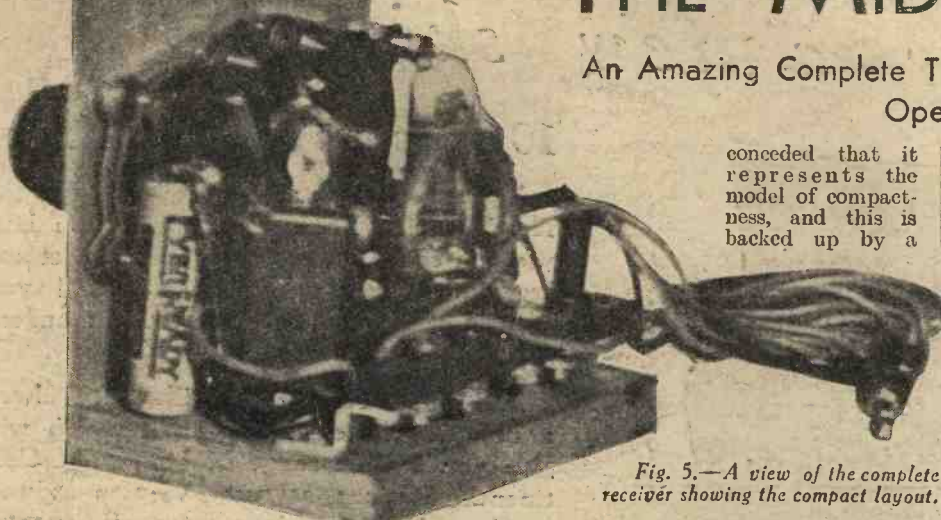

Fig. 5.—A view of the complete receiver showing the compact layout.

THERE are many different ways in which a wireless receiver can appeal to the individual, but when we consider the point of view of either the newcomer to radio or the youthful mind (both these are one and the same in very many cases) the question of novelty is quite important. Now, some time ago a midget one-valve set was designed and constructed, and this was accommodated in a cabinet no larger than a 4in. cube. The remarkable results which were obtained when this receiver was put to the test led us to experiment still further in this direction, and to try if possible, to employ more than one valve in a similar manner. Still keeping uppermost in mind the novelty appeal associated by a receiver of small size, an effort was made to produce a two-valver which could be housed in the same space and yet lose nothing in efficiency.

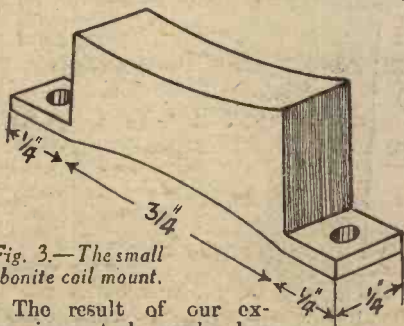

Fig. 3.—The small ebonite coil mount.

The result of our experimental work has proved most satisfactory, and the resultant Midget Two will appeal to those readers who feel that a model using one valve is not quite sufficient to give them the range and volume desired. No matter at what angle you regard this new set, it must be

conceded that it represents the model of compactness, and this is backed up by a

the detector valve, through the conventional .0003 mfd. mica condenser with a 2 megohm grid-leak in parallel.

Coupling to the second valve is by resistance capacity, and for this purpose a 75,000 ohm resistance is included in the plate circuit, while a .01 mfd. mica condenser joins the plate of V1 to the grid of V2. A .5 megohm grid-leak completes this side of the set, it being noted that there is a grid-bias cell of 1 1/2 volts included in series with the grid leak before connection is taken to the filament return.

Capacity reaction is provided through the medium of a sixty-turn hank-wound coil magnetically coupled to the tuned aerial coil. One end of this coil passes to the plate of the detector valve and the other end goes to the fixed plates of the .0001 mfd. variable condenser, which controls the magnitude of the reaction feed-back. The moving plates of this condenser pass to the earth terminal in the usual fashion.

### Valves in Series

It will be noticed that the filaments of the two valves, which, by the way, are of the Weeco type, exactly as used in the original set, are wired in series. In this way a two-volt accumulator can be employed to feed the L.T. supply. Owing to the fairly low filament consumption of these valves, namely, .25 amp., this is a very economical method, and quite a low-capacity accumulator will last for a long period. A filament switch in the positive L.T. lead completes the circuit of the set, and its very simplicity is perhaps its highest recommendation.

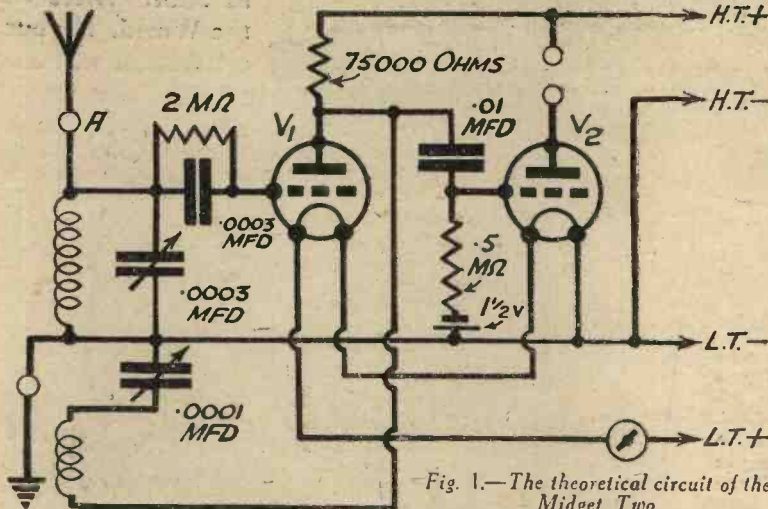

Fig. 1.—The theoretical circuit of the Midget Two.

performance which seems almost incompatible with size.

### Theoretical Circuit

First of all, a word about the theoretical circuit, shown in Fig. 1. On the aerial side we have a home-made hank coil of forty turns tuned by a .0003 mfd. variable condenser. This is coupled to the grid of the first valve,

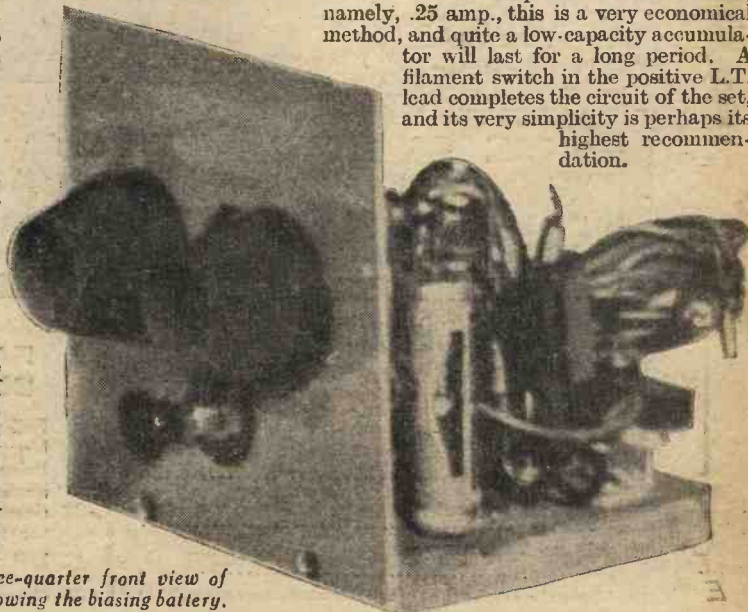

Fig. 7.—A three-quarter front view of the receiver showing the biasing battery.



**A NOVELTY SPECIALLY DESIGNED  
BY OUR TECHNICAL STAFF**

4 ins. x 4 ins. x 4 ins. The Valves are Economy Receiver, and a Novelty.

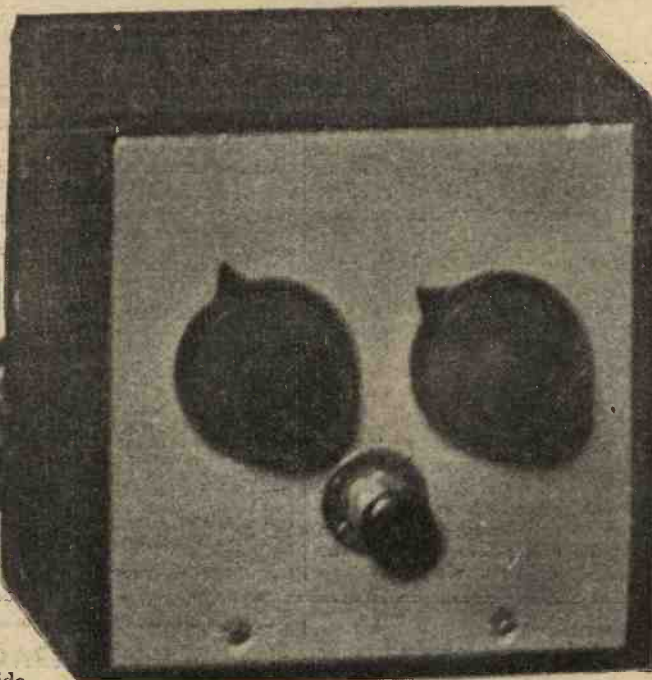

Fig. 6.—A photo of the complete receiver. This is two-thirds of the actual size.

Lay the panel on one side and turn to the baseboard. Position the valve-holders exactly as shown, noting that the filament tags do not come out at the side according to standard practice but are adjacent instead of opposite.

If you follow the wiring plan, separate filament tags on the two holders will come opposite to one another, with the plate terminal of the detector valve facing the back of the set and the plate terminal of the output valve facing the panel.

**The Coils**

Before doing anything else it is advisable to screw the panel to the baseboard and wire up the filament circuit according to plan. Then proceed to make up the coils.

The aerial coil consists of forty turns of 30 gauge D.S.C. wire wound on a cylindrical former having a diameter of 1 1/2 in. This coil is wound in hank formation, the two ends being brought out and twisted once or twice round the coil to keep it from unwinding. Do the same for the reaction coil, except that the turns number sixty in this case.

Now put the two coils together and bind them round with Empire tape, having first-marked the coil ends to ensure that you do not get them mixed. Mount the coils on the small ebonite stand shown

in the sketch, Fig. 3, so that they are held vertically by either Empire or black adhesive tape. The coils and mount can now

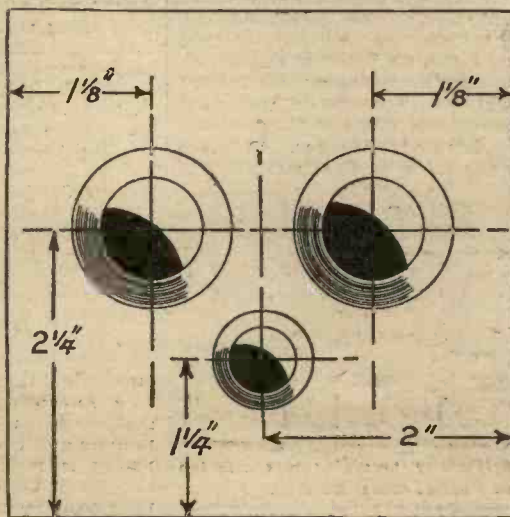

**PANEL DRILLING DIAGRAM**

Fig. 2.—The dimensions of the panel.

be screwed to the baseboard, the coil ends being left free for the moment.

**The Socket Mount**

Next make up the socket mount. This is merely a strip of ebonite, 3 1/2 in. long, 1/2 in. wide and 1/4 in. thick. Drill holes to accommodate the sockets in this strip, the hole centres being 1/2 in. apart, and two countersunk screw holes at each end to take a short bolt and nut. The bottom of the strip is raised to 1/4 in. from the baseboard by small aluminium brackets, as shown in the photographs and diagrams, the bolts (6 BA) passing through the holes provided in the strip ends, a pair of nuts

We now come to the list of components (see page 652) actually employed in the set itself. The manufacturers' names are given, and these items were chosen with great care, as it is essential to make quite sure they can be accommodated in the small space available.

First of all drill the aluminium panel according to the dimensions given in the accompanying diagram, Fig. 2, after having made sure that the panel is filed up square. Mount the two condensers directly in place, the tuning condenser being on the left facing front and the reaction condenser on the right. The spindles can make contact with the panel, since both the moving plates are made common.

The filament switch specified is insulated from the shaft and hence the panel, and if an alternative should happen to be chosen, then it may be necessary to include ebonite washers, for it will be seen that the switch is in the positive lead and hence not earthed.

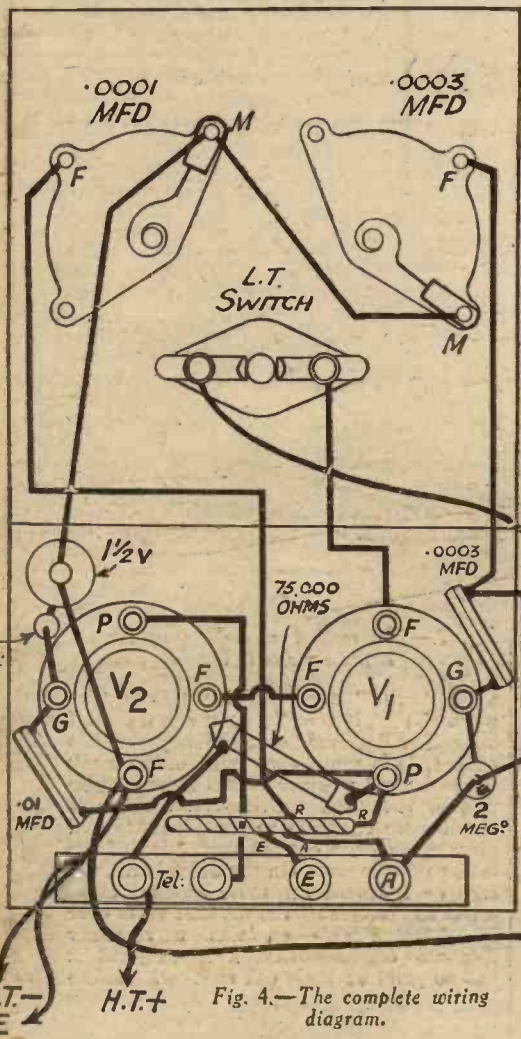

Fig. 4.—The complete wiring diagram.

holding the strip rigidly to the aluminium brackets, which, in turn, screws into the baseboard. Do not, however, screw down the brackets until the wiring is complete.

Now mount the remainder of the components in place and finish off the wiring (see Fig. 4). Note carefully that the components are held direct in position by the short lengths of wire employed, short lengths of narrow systoflex sleeving being slipped over to prevent any wires touching and causing a short circuit.

Looking at the set from the back, note that the sockets reading from left to right are as follows: phones, phones, earth and aerial. The positive and negative high-tension leads are taken off as separate leads terminating in plugs, while the 1½-volt grid-bias cell is held vertically by the rigidity of the wiring.

Although the leads look somewhat bunched, if the constructor exercises reasonable care, no difficulty will be experienced. Having finished this, and screwed the socket strip brackets to the baseboard, all is in readiness for the aerial test to prove the working efficiency of the whole set.

### Improving Reaction Control

It is often rather annoying when operating a not-too-powerful receiver to find that if the set is to be kept in its most sensitive condition the reaction knob must be used practically simultaneously with the tuning condenser. This state of affairs generally points to a badly-arranged reaction circuit—wrong size or position of windings, unsuitable capacity in reaction condenser, etc., but in most cases a cure can be effected very easily. All that one need do is to connect a resistance in series with the reaction winding. The resistance must be non-inductive, of course (a metallised one is most convenient), and its value will lie between 100 and 500 ohms. The best value will depend upon the characteristics

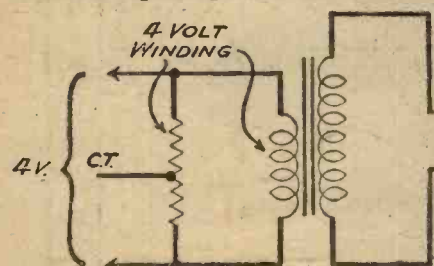

Fig. 1.—Artificially providing a centre-tap on a mains heater winding.

of the receiver and must be found by trial. When a resistance in excess of about 250 ohms is used it might be necessary to employ a reaction condenser of higher capacity than before.

### A Mains Transformer Tip

A NON-TECHNICAL friend of mine was in difficulties the other day because he wished to build the "Mains Express Three" from certain components which he had. Most of these were perfectly suitable, but he was very perturbed to find that the 4-volt winding of his mains transformer was not centre tapped. He was considering the possibilities of dismantling and re-winding it when I chanced to meet him. In the words of one of our advertisers I consoled him with "Don't worry." I explained to him that exactly the same effect as a centre tapping could be obtained by connecting a potentiometer or centre-

### Testing Out the Set

Insert the pair of valves in their holders (both are the same type) and join the L.T. leads to a two-volt accumulator and use about 80 to 100 volts for the H.T. Join the aerial and earth plugs to their appropriate sockets having first of all inserted externally, in the aerial lead, a .0001 mfd.

### LIST OF COMPONENTS

One .0003 mfd. variable condenser, compact type. (Ready Radio Ltd.)  
 One .0001 mfd. variable condenser, compact type. (Ready Radio, Ltd.)  
 Two coils—home-made (see text).  
 One 2 megohm grid leak. (Lissen, Ltd.)  
 One .0003 mfd. fixed condenser. (Graham Farish, Ltd.)  
 One 75,000 ohm resistance, 1 watt type. (Dubilier Condenser Co. (1925), Ltd.)  
 One .01 mfd. mica condenser, type M (T.C.C., Ltd.)  
 One .5 megohm grid leak. (Lissen, Ltd.)  
 One push-pull filament switch. (Whiteley Electrical Radio Co., Ltd.)  
 One 1½-volt G.B. cell, type R1010. (Ever Ready.)  
 Four plugs and sockets. (J. J. Eastick & Sons, Ltd.)  
 Two Weeco valves—type G.125, complete with bases. (Electradix Radios)  
 One aluminium panel, 4in. by 4in. by 1-16in.  
 One baseboard, 4in. by 3in. by ½in.  
 One cabinet for above. (Clarion)  
 Length of red and black flex and single rubber-covered flex.  
 One pair of headphones. (A. W. Hambling, Ltd.)

### PRACTICAL PARAGRAPHS

tapped resistance across the 4-volt terminals as shown diagrammatically in Fig. 1. In the end I made a centre-tapped resistance for him from a strip of fibre and 3 yds. of 26's gauge Eureka resistance wire. As the wire was bare it was wound on the fibre along with a length of thread to insulate the turns one from the other. A tapping was taken after winding on half the wire by making a small loop. The resistance was 8 ohms and so only consumed the negligible current of half an ampere. The constructional details are given in Fig. 2.

### Tuning Condensers

THE best capacity for aerial tuning condensers depends to a certain extent on the wave length range required from any one coil, but it should be

emphasised that the ratio of maximum to minimum capacity is more important than the maximum capacity alone. For instance, a .0001 mfd. (maximum) condenser with a very low minimum in the region of, say, 2 micro-microfarads, will cover a wider wavelength range than a .00015 mfd. condenser with a high minimum capacity. The former condenser will also prove to be much more efficient than the latter, because efficiency is always highest on any wavelength when the tuning circuit

fixed condenser to ensure a smooth reaction control.

Place the two telephone plugs in their sockets and proceed to tune in signals in the usual way. That is to say, bring in the carrier wave with the set oscillating, and then quickly reduce the reaction control and make any slight adjustment of tuning to give comfortable strength for listening to the signals.

If it should happen that the set fails to oscillate, just reverse the connections to the reaction coil and all will be well. Furthermore, try the effect of different H.T. voltages so as to ascertain that which gives the best results. Time spent in this way will repay the constructor, for nothing is more objectionable than a "floppy" reaction control.

If you have a very small loud-speaker, the set can be made to operate it, but with Weeco valves it is very easy to overload them and thus cause distortion. The best results are achieved with headphones, and even with a short length of wire round the picture rail you will be surprised at the number of stations that can be brought in with comfortable strength.

is made up of the greatest possible inductance and the least amount of capacity. It is therefore always advisable when buying a variable condenser for short-wave work to choose it, not only by its maximum capacity, but also by its minimum. The latter figure is not stated by makers of poor quality components, but these should be avoided at all costs for they are definitely not worth while.

### When a M.C. Speaker is an Advantage

MOST radio amateurs are under the impression that the reproduction from their sets is bound to be improved by using a moving-coil speaker in place of one of the

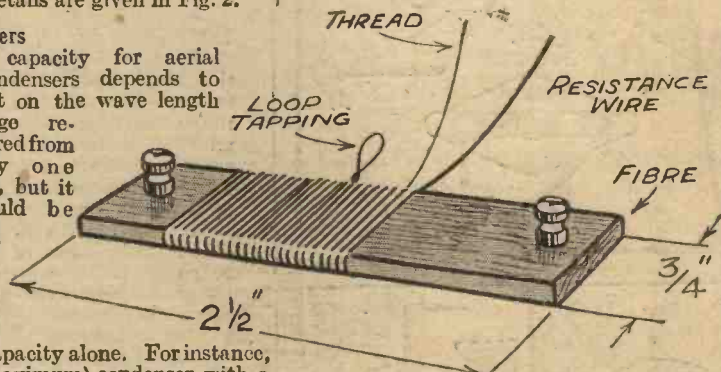

Fig. 2.—The method of making up the resistance shown in Fig. 1.

older "cone" type. Whilst this is true when the set is a really good one designed on modern lines and having a fairly generous output, it is often very wide of the mark where an old receiver is still in use. The fact is that the moving-coil speaker is much more sensitive to certain notes and gives a far more correct impression of the set's performance. On the other hand, the core or balanced armature speaker often tends to "correct" the set and gloss over its defects. This explains why many listeners consider that a moving-coil is not so good as their old speaker. Before buying a moving-coil for an oldish set it is therefore advisable to try it on the set to make sure that the latter can do justice to it.—R.P.

If you are collecting our weekly Data Sheets you should read the announcement on pages 640 and 643

**N**O doubt many readers are familiar with the popular combination adaptor now being fitted to mains wireless sets and domestic electrical appliances. It consists generally of a double attachment fitted to the end of the mains lead, having both a "bayonet" and wall-plug attachment, fitting together so that the set can be connected into either a lamp-holder fitting or a 5 amp. wall-plug socket, whichever happens to be handy for the set. The bayonet plug forms the bottom section, but the two-pin plug becomes available by withdrawing it from the bayonet plug at the top, the two pins normally fitting into a pair of sockets forming an integral part of the bayonet plug, and enabling electrical contact to be maintained when the two are together. To prevent the bayonet section from being lost when not in use a short length of retaining cord is included.

This idea is quite satisfactory when originally included with the set or domestic apparatus, but it happens often that either a bayonet plug or a two-pin plug terminates the mains lead, and it may be desirable to use the apparatus in several different positions where either a lamp socket or a two-pin wall plug is situated, but not both. Cases like this often arise when testing sets in different rooms or different houses, and to save a good deal of trouble in constantly-changing the plug, I have made up a special and very useful combination adaptor of my own. It is very simple, and I am therefore passing on the hint to readers, as they may like to duplicate the arrangement.

### A USEFUL MAINS ADAPTOR

#### Adapting the Fittings.

The scheme is shown in the accompanying photograph. First of all obtain an ordinary moulded bakelite combination adaptor having two cheese-headed screws to hold the two-pin plug in the moulded cover. Next buy a moulded bakelite batten lamp holder. Remove the moulded

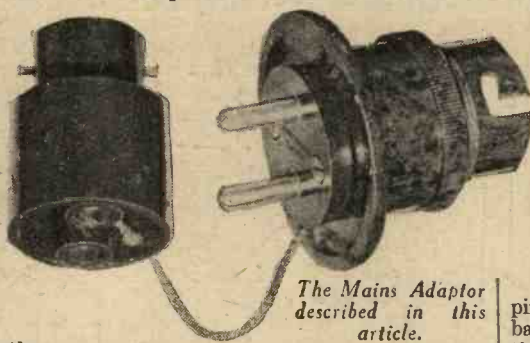

The Mains Adaptor described in this article.

bakelite cover from the two-pin plug and take out the two pairs of screws from both the batten lamp-holder and the two-pin plug, the screws in question being those used for holding in place the ends of the wires of the twin mains lead. The two-pin section will now be found to just fit against the back of the batten lamp-holder, the short metal pillars previously

holding the screws passing into the recess of the back of the batten fitting. Using the two-pin plug as a template, drill two 6 BA tapping holes into the batten fitting and either tap them with a 6 BA tap, or make a thread with an ordinary brass screw. Now link together the brass connecting pillars of the bayonet lamp-holder and the two-pin plug with a short length of flex soldered to each so that the two split pins are electrically in contact with the two brass plungers. Tuck the leads away and then screw the two-pin plug to the batten holder with two cheese-headed brass screws 1/2 in. long. The free end of the retaining cord can now be attached to the flange of the batten lamp-holder and the job is complete.

When in use if, say, a two-pin plug from the mains lead is required to make connection with the lamp-holder, separate the home-made combination adaptor, insert the lamp-holder end into position, and the two-pin plug can be pushed home into the pair of sockets. Similarly, if the mains lead terminates in a lamp-holder and only a two-pin plug position is handy, place the two pins of the adaptor into the plug and the bayonet socket is then ready to house the mains lead lamp-holder plug.—C.

#### DATA SHEET No. 2,

to be given FREE Next Week is Entitled

#### "COILS AND COIL WINDING"

THE IDEAL XMAS GIFT

Give a Wearite Heterodyne Filter to your radio friends — help them to "mush free" radio at Christmas — and after! Made in two patterns "A" to cut off at 3,000 cycles for normal use and "B" for the super music-critic to cut off at 5,000 cycles. Can be fitted to any 10/6 set.

The above graph shows the characteristics of the two types of Wearite Heterodyne Filters.

## HEAR THE CHRISTMAS PROGRAMMES — free from MUSH WHISTLES & INTERFERENCE

THERE is a host of good fare for Christmas listening—Don't let "mush," whistles, etc., distort it. Use a Wearite Heterodyne Filter, it provides a sure barrier to this form of interference. Designed to cut off those frequencies which cause heterodyne whistles, etc., the programmes alone can reach your speaker. Ask your dealer for full details—or write us direct. Special leaflet available.

### —use the new WEARITE HETERODYNE FILTER

If you are building a set for Xmas there is still time to get the Wearite Book of Components No. GN. It will help you in the choice of your parts—send now.

# WEARITE

WRIGHT & WEAIRE Ltd.,  
740, HIGH ROAD, TOTTENHAM, N.17.

Tel.: Tottenham 3847/819.

1937

# WHAT *is* TELEVISION? (3)

The Third Article of this Interesting Series by Mr. Barton Chapple, describing the Principles and Practice of Modern Television

FROM the introductory notes on the photo-electric cell, which appeared in the last instalment, the reader will have gathered that this piece of apparatus is a most important part of the television transmitting equipment. Indeed, to the unscientific mind its properties almost border on the miraculous, but its function is not a *solus* one. For example, it is not possible for one or more of these cells to convert an *entire* scene into an equivalent and electrically intelligent current variation in one fell swoop, just as, say, a photographic plate reproduces almost instantaneously the scene to which it is exposed.

There are far too many differing light values spread over any area when it is illuminated, and as the photo-electric cell gives a proportional current response for every light area to which it is exposed, a large area would only produce one average light value which, naturally, is useless for the purpose under discussion. In consequence, it becomes necessary to analyse or split up the subject or scene into a large number of elemental areas by means of an apparatus similar to that shown diagrammatically in Fig. 1. Here D is the rotating disc, L the focusing lens, C the photo-electric cells, and A the amplifier.

Each one of these tiny areas will possess a definite reflected light value when illuminated by the travelling spot of light, and the photo-electric cell is capable of responding to each of these small varying light values in turn without any time lag. We are thus able to appreciate the reason for installing the light spot transmitter. By imposing a definite geometric and predetermined path for the spot it sweeps over the area or scene to be televised, and at every instant some minute area is illuminated.

With the cells positioned according to the subject transmitted (for example, notice the cells mounted in a case on a movable stand in the accompanying illustration (Fig. 2) of a cartoonist being televised) their active surface is made to absorb, pick up, or respond to the light which is reflected from the light spot playing on the subject. A corresponding current variation is produced in the cell circuit which, as will be seen later, can be re-translated into a similar form at the receiving end.

The process is continued spot by spot and strip by strip until the whole of the subject has been verily disembodied into values of light and shade, and converted to corresponding current variations until one complete picture conversion takes place; that is, corresponding to one disc or drum revolution. The whole scanning

or exploring operation is completed without a break several times per second—twelve and a half is the number used by the B.B.C. working on the Baird process—and the signal resulting from the fact that anything white reflects more light than anything

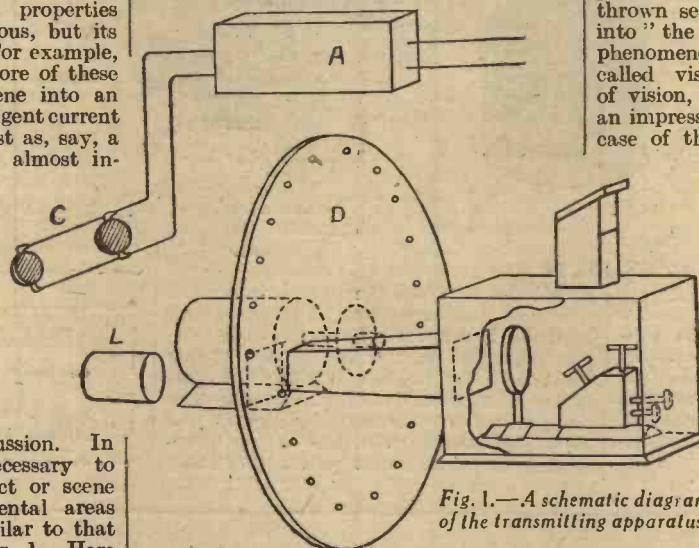

Fig. 1.—A schematic diagram of the transmitting apparatus.

black, and so on for intermediate values, is passed on to the amplifier.

### Reducing Tendency to Flicker

It is well to pause here for a moment, for I can imagine the intelligent reader saying to himself that the breaking-up process is now clear, but how is the scheme affected when artist movement is taking place before the transmitter? This is a perfectly reasonable question to ask,

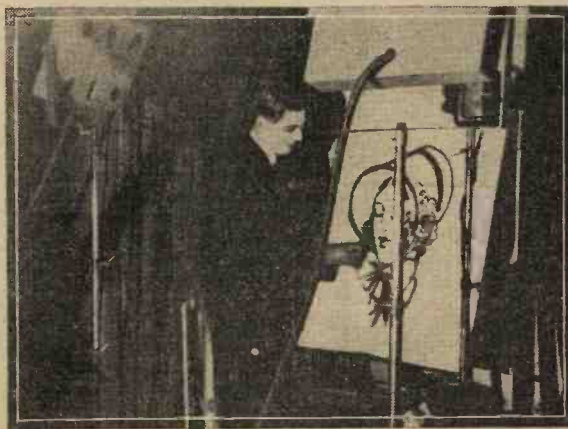

Fig. 2.—The cartoonist making his mark during the course of a television transmission similar to that which takes place from Broadcasting House.

and it has a very simple answer. It is accounted for by arranging the number of complete explorations to be ten or more (preferably more, so as to reduce the tendency to flicker) per second.

I wonder how many readers realize that, when they go to a cinema and watch the screen, the presumed movement noticed is only an optical illusion? The strip of film is passed so rapidly through the projector that each still picture which is thrown separately on the screen is "run into" the next one, and, owing to a natural phenomenon possessed by the human eye, called visual persistence or persistence of vision, there is conveyed to the brain an impression of continued action. It is a case of the quickness of the action (not hand) which deceives the eye, and we may roughly compare our disc with holes or drum with mirrors with this cinematic process.

By means of the exploring mechanism it can, in theory, be arranged to have as many complete scanning operations as desired, and the movement of the artist is thus catered for. Before leaving this side of our intriguing subject—quite a simple one, really, when shorn of its complicated technicalities and refinements, which do not have a real bearing on the principles—let us consider for a moment what are the limitations now

existing which prevent television from being on a level, as far as detail is concerned, with, say, the home cinema. This development of the art is bound up with laws of broadcasting which, in Europe, prevent a greater sideband width than 9 kilocycles to be used for any station operating on the medium waveband.

Obviously, the more strips into which a transmitted scene can be dissected, and the higher the rate with which the operation is repeated, the greater will be the amount of detail transmitted, and flicker will vanish. For this to happen, however, a wide sideband is required, so on the medium waveband a compromise is arrived at between the shape of the picture, the number of scanning lines, and the number of complete explorations carried out in one second. For example, with the regular television programmes emanating from Broadcasting House, we have a picture in the shape of a rectangle bearing the ratio of seven vertical to three horizontal, thirty scanning strips and 750 pictures per minute. With this, however, remarkably good programmes can be transmitted; in fact, due partly to the situation that most of the characters are undergoing continual movement during the course of their turn before the television transmitter, and this coupled with the self-accommodating character of the human eye and its tolerance, impart to the observer quite a lot of detail which a rigid theory would prove impossible.

If you look at any scene yourself, you

# DIRECT RADIO LTD

**BUY DIRECT—DELIVERY GUARANTEED FOR CHRISTMAS**

## THE "SOLO-KNOB" THREE

£ s. d.		£ s. d.	
1	Lissen Ganged Condenser Tuning Control Unit .. 14 6	1	10,000 ohm spa- shell resistance .. 1 0
1	Telsen Screened coil .. 8 6	1	Baseboard fuse holder and fuse .. 1 0
3	W.B. Valve Holders .. 1 6	1	Belling Lee 5-way battery cord .. 2 6
1	Ready Radio H.F. Choke .. 2 6	3	Valves to specification .. 12 9
1	Ready Radio 5-1 L.F. Transformer .. 9 6	1	" 150 " Walnut Cabinet .. 17 6
1	Telsen Acc 3-1 L.F. Transformer .. 5 6	1	Ebonite panel 12in. by 7in. Permcol. Ready drilled .. 4 0
1	T.C.C. 2 mid. fixed condenser type No. 50 .. 3 10		Levros connecting wire, screws, hex, 2 wander plugs, etc. .. 2 0
1	T.C.C. 0002 mid. fixed condenser type "8" .. 1 3	2	Belling Lee terminal blocks .. 1 4
1	Grid Leak holder .. 6	4	Belling Lee terminal blocks A.B. L.S. + L.S. .. 10
1	Gramm Pariah 2 megohm Ohmite Resistance .. 1 6		
			<b>£5 0 0</b>

## "ARGUS" THREE

- Kit No. 1 £5 2 6**  
(less valves and cabinet) or 12 monthly instalments of 9/6.
- Kit No. 2 £7 13 0**  
(with valves less cabinet) or 12 monthly instalments of 14/-.
- Kit No. 3 £8 13 0**  
(with valves and cabinet) or 12 monthly instalments of 16/-.

- Kit No. 4 £11 5 0**  
or 12 monthly instalments of 21/-.
- Complete with Valves, handsome "150" Walnut Console Cabinet and Epoch Twentieth Century Moving-Coil Speaker with input transformer.

## "SONOTONE" FOUR

- |  |   |  |
|--|---|--|
| <b>Kit - £5 12 6</b><br>Model 1 (less valves and cabinet) or 12 monthly payments of 10 6 | <b>Kit - £7 11 6</b><br>Model 2 (with valves less cabinet) or 12 monthly payments of 14 0 | <b>Kit - £8 10 0</b><br>Model 3 (with valves and cabinet) or 12 monthly payments of 15 6 |
|--|---|--|

## "EMPIRE SHORT WAVE III"

- KIT Model No. 1** (Less Valves and Cabinet) **£5 0 0**  
or ten monthly payments of £0 : 11 : 0
- KIT Model No. 2** (with Valves less Cabinet) **£6 2 9**  
or ten monthly payments of £0 : 14 : 0
- KIT Model No. 3** (with Valves and Cabinet) **£7 2 9**  
or ten monthly payments of £0 : 16 : 0
- KIT Model No. 4** (Complete kit, including Valves, special Console Cabinet, Blue-spot 100U Inductor Dynamic chassis, Aerial, Earb and Battery equipment) **£11 11 0**  
or 12 monthly payments of £1 : 1 : 0

## READY RADIO

**THE "303" Model A** (with valves, cabinet and moving coil speaker). Price **£8 : 17 : 6.** 12 monthly payments of 16/-.

**METEOR S.G.3 Model A** (with valves, cabinet and moving coil speaker). Price **£8 : 17 : 6.** 12 monthly payments of 17/-.

**Model B** (complete kit with valves only). Price **£5 : 7 : 6.** 10 monthly payments of 12/6.

**EVEN IF THE ITEM YOU WANT IS NOT LISTED WE HAVE IT !!!**

**WRITE, 'PHONE OR TELEGRAPH YOUR ORDER.**

'Phone: Hop 3000. 'Grams: "Dirrad, Sedist, London."

## "S.T. 400"

**READY RADIO S.T. 400**

**Complete Kit, £4 : 17 : 6**

Or deposit of 9/6 and 11 monthly payments of 9/9

**MODEL A**

Complete Kit, with four specified valves and beautiful walnut cabinet fitted with moving coil speaker. **£10 : 10 : 0**

Or deposit of 20/- and 11 monthly payments of 21/-.

**MODEL B**

Complete Kit, with four specified valves. **£6 : 16 : 9**

Or deposit of 12/6 and 11 monthly payments of 13/9.

**ACCESSORIES**

SPEAKERS	£ s. d.
Epoch Twentieth Century Moving Coil	1 15 0
Epoch Super Junior	1 7 6
Epoch A.2 Dance Orchestra	3 3 0
or 10 monthly payments of	7 0 0
W.B. P.M.	4 5 0
or 12 monthly payments of	9 0 0
W.B. P.M.A.	2 2 0
Super permanent magnet moving coil chassis	
R. & A. Victor permanent magnet moving coil chassis	8 10 0
or 10 monthly payments of	7 9 0
R. & A. Challenger Moving coil chassis	1 15 0
R. & A. Bantam Moving coil chassis	1 7 6
Bluespot 100U Inductor chassis	1 12 6
Bluespot 60R Unit and Major Chassis	2 10 0
Bluespot 44R. Oak Cabinet Speaker	2 13 6
R. & A. Type 30 Unit and Cone.	15 0

BATTERIES AND ELIMINATORS	£ s. d.
Siemens 120 Volt Standard	13 6
Siemens 120 Volt Power VS	1 4 0
Siemens 9 Volt G.B.	1 0
Siemens 16½ Volt G.B.	1 9
Oldham 9.50 2 volt Accumulator	12 6
Oldham 0.75 2 volt Accumulator	12 6
Oldham 120 volt Wet H.T. Accumulator, 5500 mahour capacity	4 1 0
or 12 monthly payments of	7 6
Block 2 volt L.T. accumulator 80 amp. hours	11 6
Atlas A.2 H.T. Eliminator	2 19 6
or 10 monthly payments of	6 0
Atlas A.C.244 H.T. Eliminator	2 19 6
or 10 monthly payments of	6 6
Atlas A.K.200 H.T. Eliminator, with Trickle charger	4 10 0
or 12 monthly payments of	8 6
Atlas A.C.300 H.T. Eliminator, with G.B. and Trickle Charger	6 10 0
or 12 monthly payments of	12 0
Atlas DC 15/25 H.T. Eliminator for D.C. Mains	1 19 6

PICK-UPS	£ s. d.
Daptacon	10 6
A.E.D. Mark III	1 10 0
BTH. Minor with Volume Control	1 5 0

**DIRECT RADIO S.T. 400 DE LUXE MODEL KIT No. 1**

(Less valves and cabinet) **£5 : 15 : 0**  
or twelve equal monthly payments of 10/9

**KIT No. 2**  
(with valves less cabinet) **£7 : 17 : 0**  
or twelve equal monthly payments of 14/6

**KIT No. 3**  
(with valves and cabinet) **£9 : 2 : 0**  
or twelve equal monthly payments of 16/6

**KIT No. 4**  
(with valves and special "150" S.T. 400 De Luxe Console Cabinet and Epoch A2 Dance Orchestra Speaker.) **£12 : 15 : 0**  
or twelve equal monthly payments of £1 : 4 : 0

**EXTRA SPECIAL XMAS GIFT SUGGESTIONS**

	£ s. d.
PIFCO De Luxe Set Tester	2 2 0
HENLEY Electric Soldering Iron, very handy and reliable	7 6
SELECTANET Aerial	2 6
SELECTANET Earth	1 6
GRAMM PARIAS & PHIT Earth	2 6
COF Lightning Arrester and lead-in tube	2 6
CLIX Constructor Kit of Terminals, etc.	3 0
Wireless Calibrator Station Finder	1 0
LESSEN Sky-scoper Kit	4 9 6
12 monthly payments of	8 6
STATONMASTER 111. Battery Kit A with Cabinet	6 11 0
or 12 monthly payments of	10 6
STATONMASTER R 111. A.C. Chassis Model	10 10 0
or 12 monthly payments of	19 0
ELECTRON Aerial (75 feet)	2 6
COSSOR 338. All-electric Kit with Valves (but without cabinet) or 12 monthly payments of	8 15 0
or 12 monthly payments of	16 6

*New Set of Mullard Valves for any set; ask for our expert advice, and prices.*

**DIRECT RADIO ALL WAVE III**

**Kit with 3 Mullard valves and full instructions for construction and use. £2 7 6 only**

**Guaranteed Results, Ultra Short, Medium and Long Waves. Limited stock.**

**Special Cash offer. Order now before supplies are exhausted.**

Collaro Double Spring Motor with Automatic Stop	1 13 0
Collaro A.C. Induction Motor	2 10 0
Collaro A.C. Playing Unit with Pick-up in one assembly	4 0 0
A.C. Motor tunable and volume control in one assembly or 12 monthly payments of	7 6

**CASH, C.O.D. AND EASY PAYMENT ORDER FORM.**

To: Direct Radio Ltd., 159, Borough High Street, London Bridge, S.E.1.

Please despatch to me at once the following goods .....

for which (a) I enclose (Cross out line) (b) I will pay on delivery {not applicable} (c) I enclose first deposit of

NAME .....

ADDRESS .....

FOR XMAS DELIVERY ..... Fr. W. 17-12-32

### WHAT IS TELEVISION?

(Continued from page 654.)

unconsciously scan it by allowing your eye to wander over it in much the same way as the television scanning spot. Before there has been an opportunity of absorbing all the detail of a televised subject or person in one position, it has moved to another, and thus unconsciously the amount of noticeable detail is less than would be the case for stationary objects.

#### Objects with Sharply-defined Outlines

When any attempt is made to transmit objects having sharply-defined outlines, the resultant image seen in the receiving apparatus has a rather softened effect. In any case, it is just as foolish to attempt to watch a television image with the eye close to the apparatus as it is to get up close to an artist's painting and criticize the work because you can see the daubs of paint or water-colour. Just stand or sit three or four feet away, and the observer will have the effect of the light and shade, building up the image being distributed over the surface somewhat in the form of a wash drawing. These points have been purposely

emphasized so that the reader, when he comes to consider the receiving end, will view the matter with the correct attitude of mind.

Once the signal impulses emanating from

"sound currents" from a studio microphone. They are then broadcast into space, but before we migrate to the receiving end just study carefully the last photographic illustration (Fig. 3) so as to impress the transmitting process as a whole on your mind.



Fig. 3.—Portraying the complete transmitting side when using a portable mirror drum transmitter, with photo-electric cells, back screen and artist in position.

the travelling light spot's reflections being translated into terms of current have been amplified, they are made to modulate the high-frequency carrier wave of the wireless broadcasting station in a manner similar to

full reception of television—that is, sound plus vision—two separate receivers are required; one connected to the vision apparatus, and the other to the sound apparatus.

(To be continued)

### RECEIVERS AND THEIR RECORDS

(Continued from page 644.)

lengths. The inner knob, concentric with the ring, operates as an aerial trimmer, which provides a final adjustment when necessary.

Although the volume-control applied to the grid-bias on the first high-frequency stage works very effectively, in the case of reception of a powerful local transmission another means has been found to tone down the strength of the signals. At the back of the cabinet, a local distance-switch has been incorporated; when brought into action it imposes a 2,000 ohm. load in the grid circuit of the second detector, and thus reduces the efficiency of the preceding stages. In this way, all risk of the second detector valve being overloaded is obviated. Under test, the receiver put up a constant superhet performance on both wavebands; it was highly efficient both as regards sensitivity and selectivity. The advantage of a frame aerial, and its inherent directional properties, was amply proved when dealing with "difficult" transmissions, with unpleasantly close and powerful neighbouring broadcasts, and such stations as Mühlacker, Breslau, Poste Parisien, Strasbourg, Brno, Brussels, and Milan were received without interference. With care it was possible to tune in Radio-Normandie and Cork clear of each other, by a slight alteration in the direction of the frame aerial, and the same applied to North National and Bordeaux-Lafayette.

On the bottom of the medium waveband, several low-powered broadcasts were logged, and throughout the scale the qualities of a well-designed superhet were noticeable,

inasmuch as the turning of the tuning-ring and judicious adjustment of the trimmer brought in one transmission after another at good readable strength. In the case of transmitters rated at high-power, in each instance it was imperative to reduce volume. On the longer waves, Königs Wusterhausen was quite clear of Daventry and Radio-Paris.

The instrument is provided with aerial and earth terminals, and where reception conditions are unfavourable for certain transmissions, this may be found of considerable help, but it must be borne in mind that the connection of an outside aerial much reduces the directional properties of the frame. In addition, the receiver may be also used for the electrical reproduction of gramophone records, as provision has been made for this facility, and also, where required, it is possible to connect an extra external loud-speaker. Finally, the quality of tone, in both speech and music, given out by the moving iron loud-speaker is satisfactory for a portable receiver, but care should be taken not to push up the volume to the extent of overloading the valves when dealing with strong signals. The all-round efficiency of this superhet receiver redounds to the credit of the H.M.V. engineers, and for a receiver of this kind, the price of £17 17 0 is a reasonable one. *The H.M.V. Six-Valve Portable* can be recommended to any listener who wishes to hear transmissions from a large number of European stations at any time during the day; with it there is no difficulty in tuning in some twenty or more programmes nightly, at good loud-speaker strength.

### ODDS AND ENDS

#### American Heterodyning

HETERODYNE interference has been so bad in the U.S.A., due to stations "wandering" from their official wavelengths, that all stations are having to fit a frequency monitor, and to keep their frequency within 50 cycles of that officially assigned to them. It is calculated that the modifications will cost something like the equivalent of £150,000. The order was passed by the Federal Radio Commission last June, and stations were given a maximum period of twelve months in which to carry out the necessary alterations.

#### Frequency Records

BY the way, do you know that you can test the frequency response of your set, if provided with pick-up terminals, by the use of constant frequency records? These are made by two or three of the larger gramophone companies, and will be found ideal for the purpose in question. They contain a series of pure notes covering a wide band of frequencies, and the frequency at several points on the scale is announced, so that you can make rapid comparisons. Another series of records giving "samples" of music by some thirty different orchestral instruments is also available, and will prove invaluable to those experimenters who are "all out" for quality in reproduction.



# The BEGINNER'S SUPPLEMENT

Conducted by  
F. J. CAMM

### Beam Wireless

A SYSTEM of communication employing extremely short wireless waves. These have somewhat similar properties to light and heat and such-like rays in that they can be focused into a beam. Advantage is taken of this property to use an aerial system employing a network of wires forming a huge reflector.

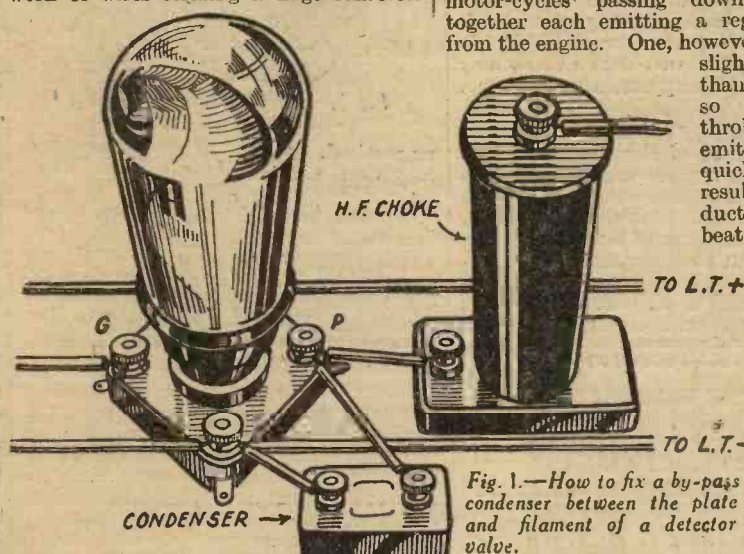

### THE BEGINNER'S A B C OF WIRELESS TERMS

stance, it is also to be found in sound waves. You may have noticed two motor-cycles passing down the road together each emitting a regular throb from the engine. One, however, is geared slightly higher than the other so that the throbs are not emitted quite so quickly. The result is the production of a beat note or throbbing which in frequency is slower than the note from either of the two engines alone. The notes seem to blend in such a way that they produce a peculiar rhythmic rise and fall in the

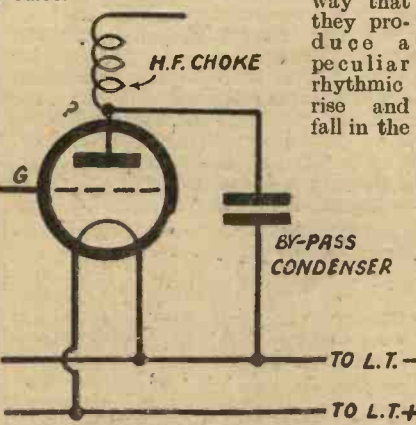

In such a way the waves can be focused in the direction of the receiving station and will not cause interference with receivers outside the beam. This in itself is a great advantage for commercial work but perhaps a still greater one is the saving of power. Instead of radiating in all directions, as with a broadcasting station, the whole power of the transmitter is concentrated in the one direction only.

### Beats

If two alternating currents, each oscillating at a different frequency, are superimposed, they will combine to form a current oscillating at a frequency different from either of the two. They will produce a "beat note." The frequency of this beat note will be equal to the difference in the two original frequencies. Thus, for example, if one of the two original currents is pulsating at the rate of 30,000 and the other at 25,000 cycles per second, the resulting current would oscillate at 30,000 - 25,000 cycles—namely 5,000 cycles. If you are not familiar with the terms "alternating current," "frequency" and "cycles" see "Alternating Current." However, the beat principle is not confined to electrical currents. For in-

volume of sound emitted as the machines pass. Incidentally the super-heterodyne type of receiver works on the beat principle. It is a fact that it is easier to amplify low frequencies than high frequencies; therefore in the superhet the high-frequency oscillations received on the aerial have superimposed on them another

set of oscillations generated by the receiver itself. This produces a beat frequency which is considerably lower than either of the two component frequencies from which it is derived. It is this beat frequency which is then amplified and rectified in the usual way.

### Beverage Aerial

An aerial the length of which is a multiple of the length of the waves to be received. This means that it is usually very long. For instance, if it is only twice as long (it may even be three or four times) it would have to be 600 metres in length for receiving a transmission from a station broadcasting on a wavelength of 300 metres. A Beverage aerial is erected only a foot or two above the ground and the free end is sometimes earthed. Its special characteristics are that it is strongly directional and is less sensitive to atmospherics than the more orthodox types.

### Binding Post

Another name for a terminal.

### By-Pass Condenser

In a wireless receiver it often happens that currents of different frequencies are flowing in the same path. In the anode circuit of a detector valve, for instance, there are both high- and low-frequency currents present. Now, for certain reasons it is often necessary that some particular band of frequencies should be excluded from a circuit. This is where the by-pass condenser comes in. Its function is to provide an alternative path for the unwanted frequencies—that is to say it "by-passes" them in much the same way as a by-pass road diverts certain traffic from the main thoroughfare.

Fig. 1 shows how a small fixed condenser of about .0002 mfd. or .0003 mfd. is sometimes connected between the plate (anode) of the detector valve and its filament in order to by-pass

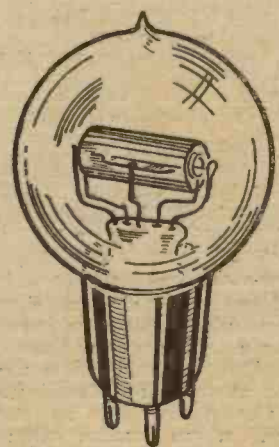

Fig. 3.—A bright emitter valve.

some of the high-frequency currents which might otherwise pass through the anode circuit and cause instability or distortion.

**Blocking Condenser.**

A fixed condenser placed in a circuit so as to stop the passage of direct current but of such a capacity as to offer a ready path for certain alternating currents.

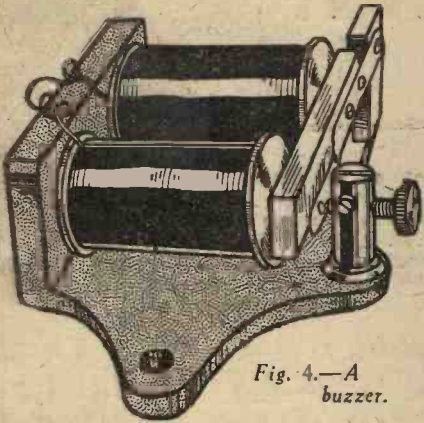

Fig. 4.—A buzzer.

**Bornite**

A natural mineral composed of iron and copper sulphides. Used in conjunction with zincite (another mineral) it acts as a detector for wireless. A bornite-zincite crystal detector is usually made by mounting each of the two minerals in separate metal cups. The two cups face one another so that the crystals touch. The pressure between the two can be varied by means of an adjustable spring.

**Bright-Emitter Valve**

A valve in which the filament is heated to a very high temperature so that it glows like the filament of an electric lamp. All early types of valves were bright emitters. Modern valves, on the other hand, are dull emitters, their filaments being of a special nature so that they will give a full emission of electrons when heated only to a dull red. This, of course, effects a considerable saving in current. Many bright emitter valves took as much as .75 amp at 4 volts to heat the filaments; in other words, they required a power of 3 watts (.75 amp x 4 volts) whereas their modern counterparts need only about .1 amp and 2 volts—that is .2 watt or only one fifteenth of the power.

The life of a bright emitter usually depended on how long the filament remained intact. It must be remembered that owing to the excessive heat used there was considerable strain due to expansion and contraction when the set was switched on and off. Also the filament tended to become thin owing to the throwing off of minute particles of the metal in the same way as metal is expelled from the filament of an electric lamp, causing the well-known blackening of the bulb which appears after long use.

**Buzzer**

A simple piece of electrical apparatus which vibrates rapidly when a current is passed through it thus causing a buzzing noise. From this it derives its name. The commonest form of buzzer is similar in construction to the operating mechanism of an electric bell—in fact, an old bell is often used as a buzzer by removing the hammer and bell. Fig. 4 shows what

a buzzer looks like, while Fig. 5 is a diagram of the circuit. The current from a battery or other source flows through the two coils L causing the iron core B to become magnetised and attract the piece of iron, or armature A. This goes “click” on to the magnet and, in doing so, breaks the circuit at the contact C. The current immediately stops, and the armature flies back to its original position by the aid of a spring. Once more the circuit is completed, and the flow of current again causes the core to become

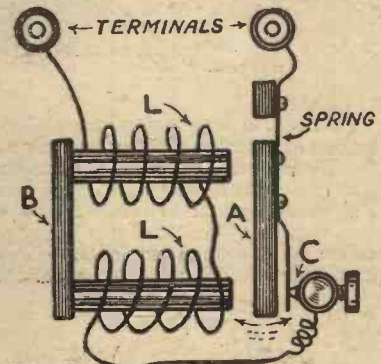

Fig. 5.—Diagram showing how the buzzer works.

magnetised. Again the armature jumps towards the magnet, breaks the circuit, springs back again, and so on. The use of buzzers in radio is dependent on the fact that they radiate electro-magnetic waves from the contact breaker. By means of a suitable tuned circuit a buzzer can be fitted up as a miniature transmitting station or as a wave meter.

**I**NTERVALVE coupling by transformer on the L.F. side has now become so general that few receiving sets are constructed without one such stage. The graphs published showing the relation of gain to frequency are such as to justify the accepted practice in this respect; and these graphs when put forward by a firm of repute or properly certified by an independent authority (within the usual plus or minus ten per cent. for a commercial product) may be considered quite reliable. Without the use of resonance it is admitted on all hands that there would be a very substantial loss of amplification (or gain) in the upper acoustical frequencies, but by the use of resonance this is avoided and, in fact, a distinct “hump” is achieved in the response curve in the region of 3,000 to 4,000 cycles, and after that a rapidly falling characteristic, all of which is very pretty and very desirable. In a poorly-designed intervalve transformer the hump may be in the wrong place or may be a very decided “peak,” but we exclude such from discussion; we assume that the design is such as to produce the best possible form of graph for the service required.

**Resonance**

Now in any resonant circuit the full amplitude of oscillation is only acquired after a certain lapse of time. The initial amplitude of swing when the first of a train of waves is received is just the same as though there were no resonance, and then during successive pulses the amplitude increases progressively, gradually approaching a maximum (see diagram);

**FROM THE FLASHLAMP (2)  
INTERVALVE COUPLING  
By PHOTON**

there is nothing new in this. It is this maximum value that is recorded as due to resonance in the published transformer characteristics, the graphs referred to above. And in the rendering of musical tones the results are fairly represented by the graph, including the resonance factor. The period of growth in the amplitude of a tone after its first onset to its attaining full strength is not usually noticeable; it is comparable to the “building up” of

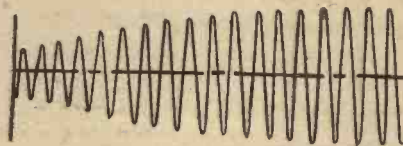

Showing how oscillation gradually attains maximum amplitude.

an organ tone, and for the same reason. When the wind is first admitted, the air in an organ pipe is not at once set into vibration, but takes many cycles to attain its full amplitude; the result is that softening of attack which is one of the characteristics (and some think a defect) in the ordinary (pipe) organ.

**Reproduction of Transients**

Although this “softening of attack” may pass unnoticed in the reception of a musical programme—and, indeed, it takes an exceptionally keen and trained ear to notice it—it is not so with speech. The consonants in speech, more particularly those containing what are termed *transients*, depend for their perfect enunciation implicitly on the *attack*; that is to say, if any given frequency is involved in the initial phase of a sound of explosive character such as a “p” or a “t,” it is the initial amplitude that counts, and not the amplitude reinforced by resonance. Consequently, the graph which includes the effect of resonance is invalid, and cannot be regarded as applying to the reproduction of transients or sounds of explosive character.

There can be no doubt that the “crispness” of music of an intimate character, as, for example, the string quartet, must suffer in lesser degree. Realism in the precision of the attack of the bow on the string is to some extent lost, but probably no more so than might be due to distance, as when the listener is at the back of a concert hall.

**IF YOU ARE A REGULAR  
READER—  
THE ANNOUNCEMENT ON  
PAGE 643 IS MEANT FOR  
YOU!**



# BALANCED CAPACITY

GIVES LONGER LIFE

AND HIGHER AMPERE HOUR

EFFICIENCY



- Type E.L.9. 80 a/h capacity    **12/3**  
Price - - - - -
- Type E.L.M.4. 45 a/h capacity    **8/-**  
Price - - - - -
- Type E.L.S.7. 60 a/h capacity    **12/6**  
Price - - - - -

● That's the secret, "balanced capacity," the newest principle in modern accumulator making.

The scientific design of the positive and negative plates which preserves exact electrical "balance" allows this accumulator to be charged more quickly, and to give a longer life per charge. Twenty-five years experience in battery building has gone to produce the Ediswan "Extra Life" cell. Here are some of the additional refinements incorporated: screwed vents, non-interchangeable and non-corrodible connectors, British made containers of clear glass and metal carriers which fit neatly round the containers.

# EDISWAN ACCUMULATORS

*EXTRA LIFE*



THE EDISON SWAN ELECTRIC CO. LTD.  
155 CHARING CROSS ROAD, LONDON, W.C.2

B.204

"A definite advance..."



says Mr. H.J. Barton Chapple *Wh. Sch. B.Sc. (Hons) D.I.C. A.M.I.E.E.*

*This well-known radio and television authority pays striking tribute to the new W.B. "Mansfield" Speaker Magnetic System.*

"... The ultimate result is a really astonishingly high flux density for the size of the magnet used... fidelity of tone of outstanding merit... sensitivity very noteworthy, comparable in many respects with externally energised types without the necessity for mains or batteries. The Speaker will handle an input more than sufficient for quite a large room and yet can be worked satisfactorily from a small two-valve set.

"My conclusions... this new P.M.4 speaker is a definite advance in the permanent magnet class."

Write for copy of Mr. Barton Chapple's full report. The "Mansfield" (patent) Magnetic System is a revolutionary development. It makes possible a magnet 30% more efficient than a good cobalt steel magnet of same weight and 10% more efficient than a chrome steel magnet of three times the weight. It enables a steel chassis to be used without magnetic loss. It eliminates the bugbear of loss of magnetism. Ask your dealer for a demonstration; you will be AMAZED.

The revolutionary "MANSFIELD" Moving-Coil Speakers



- "Mansfield" Senior (Improved P.M.4) complete with 3-ratio transformer    **42/-**
- "Mansfield" Junior (P.M.5) complete with 3-ratio transformer    **27/6**
- "Mansfield" Cabinet in well-finished Oak (for P.M.4 or 5)    **25/- extra.**

Whiteley Electrical Radio Co., Ltd., Dept. E, Radio Works, Mansfield, Notts. London Office: 109 Kingsway, London, W.C.2. Phone: Holborn 6714. Irish Free State Distributors: Kelly & Shiel, Ltd., 47 Fleet Street, Dublin.



PUBLISHED BY  
TELEGRAPH CONDENSER CO

**This Book will save you money**

WITH electric light in the house—with ample power at your elbow, why use costly and inefficient batteries? From the moment you connect your batteries the power starts to decline—reproduction suffers, and soon—replacement! Get a copy of this book—it will tell you how—if you are on A.C. supply—to cut out battery costs and get better and more powerful radio. There is also an interesting and informative chapter on D.C. apparatus. If you have electric light you need this book.

**CONTENTS**

- RADIO POWER UNITS—and how to build them.
- NOTES ON A.C. POWER UNITS.
- OPERATING RECEIVERS ON D.C. MAINS.
- ABOUT T.C.C. ELECTROLYTIC CONDENSERS.
- ELIMINATION OF INTERFERENCE.
- FOUR T.C.C. POWER UNITS with full constructional Details.
- ROTATING RESISTANCE CALCULATOR.

**T.C.C.**  
ALL-BRITISH  
**CONDENSERS**

© 1976.

**COSTS ONLY**  
**9'6**

**FOR ALL MAINS OR BATTERY SETS**

Consists of Automatic Relay completely enclosed in Bakelite case, size 4 x 2½ x 2¼ ins. Simple to instal.

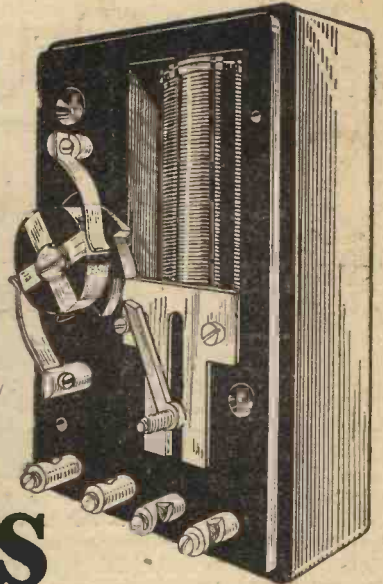

**WATES Distance Switch**

Operating power merely a flash lamp battery controlled by any number of ordinary 'bell pushes.' Foolproof: no danger to set or person. Adds tremendously to the value of any set.

**GIVES YOU RADIO ALL OVER THE HOME**

**EXTRA SPEAKERS WHEREVER YOU LIKE**

**SET SWITCHED ON OR OFF FROM ANY ROOM**

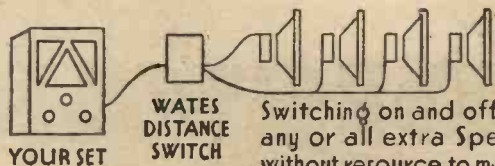
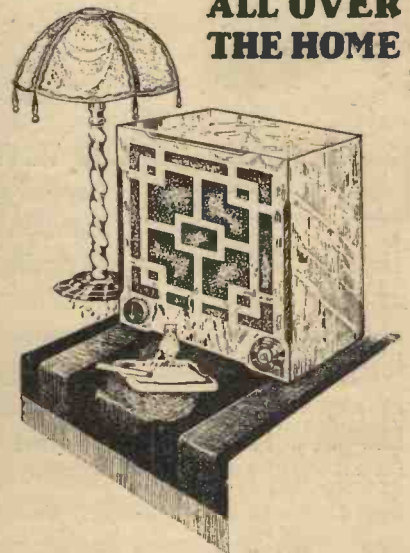

YOUR SET  
WATES DISTANCE SWITCH  
Switching on and off from any or all extra Speakers without resource to main Set

Of Radio Dealers, Ironmongers, etc., with Simple Instructions  
Send Postcard Now for folder "Radio & Comfort"

**WATES RADIO LTD**  
184-188 SHAFTESBURY AVENUE LONDON W.C.2

**Ask your Dealer**

If you have any difficulty in obtaining a copy of this book, fill in the coupon and post to us with six penny stamps. We will send you a copy by return.

**COUPON**

To Publicity Dept., The Telegraph Condenser Co., Ltd., Wales Farm Ed., N. Acton, London, W.3.  
Please send me a copy of your book, "The Design and Construction of Radio Power Units," for which I enclose six penny stamps to cover cost and postage.

NAME :-

.....  
.....

ADDRESS :-

.....  
.....

Form 1779/32

PLEASE WRITE IN BLOCK LETTERS

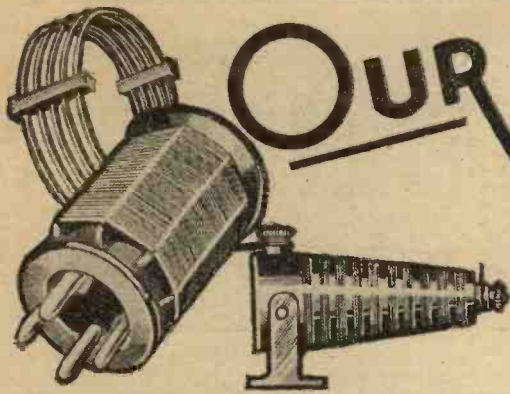

# OUR SHORT-WAVE SECTION



**E**FFICIENT short-wave chokes of the high-frequency type can be made at home quite easily, and the cost need not exceed a few pence apiece. In fact, many wireless enthusiasts probably have sufficient odds and ends already in their possession to provide the materials required for the construction of simple chokes such as that shown in the accompanying illustration.

The materials needed are: 2 in. of ebonite tubing about 1 in. in external diameter, strip of ebonite 3 in. by 1 in. by 3-16 in. thick, 2 4BA screws (counter-sunk type), 3/4 in. long, 2 4BA screws, say 1/2 in. long, fitted with nuts and terminal heads; 2 washers, and an ounce or so of fine-gauge enamelled or silk-covered copper wire. The external diameter of the ebonite tubing should not exceed 1 in., but it may be a little less; the thickness of the "wall" of the tube may be about 3/16 in., but here again the measurement is not very critical; and the wire used for winding the chokes may be of any gauge not heavier than 32 and not finer than, say, 38 or 40 S.W.G. As such considerable latitude is allowable in the dimensions of the parts, it will be realized that the

## Making Efficient Short-wave Chokes

By "Radioman"

### Details of Construction

First the ebonite tubing is clamped in a vice (with some soft material over the jaws of the latter to protect the surface of

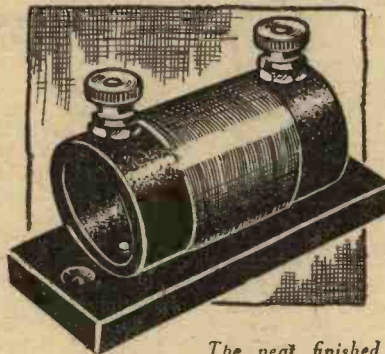

The neat finished choke described in this article.

of these holes are indicated at "B" in Fig. 1.

Next, the ebonite base is drilled as shown at "C," Fig. 2, the inner pair of holes being 4BA clearance size, and counter-sunk on the *under side* of the ebonite; the outer pair, which should be counter-sunk on the *upper surface* of the ebonite base, are to be of a suitable diameter to take the fixing screws that will ultimately secure the finished choke to the baseboard or chassis of the set.

### Winding the Coil

A single-layer winding of the fine-gauge insulated wire is then put on the tube. This winding may be of the plain type shown in the illustration to this article, or it may be sectionalized. The number of turns depends to some extent on the waveband over which the choke is required to be effective. Between the terminals on the choke-former there is space for a winding about 1 1/2 in. long; the maximum number of turns that can be accommodated depends on the exact gauge of wire used and on whether the winding is plain or sectionalized. For general purposes, however, about 75 to 100 turns of wire will probably be found satisfactory. The wire should preferably be put on under moderate tension.

On completing the winding, mount the terminals in the holes drilled to receive them, bare the ends of the wire by scraping off the insulation very gently, and connect them to the terminals.

To complete the job, mount the tube on the ebonite base by running the pair of 4BA screws through the holes in the base into the tapped holes prepared for them in the tube; but first slip a pair of washers (marked "Y" in Fig. 3) on to the screws to keep the winding clear of the ebonite base.

DRILL 4 B. A. CLEARANCE

DRILL AND TAP 4 B. A.

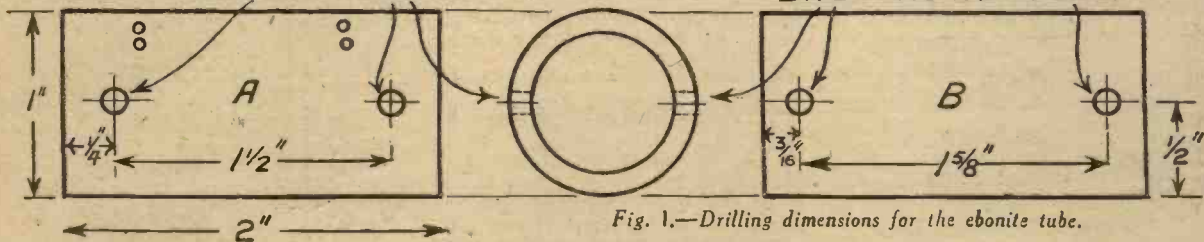

Fig. 1.—Drilling dimensions for the ebonite tube.

construction of these chokes affords a good opportunity for using up old "junk." The ebonite, etc., used should, however, be of good quality.

the ebonite) and drilled as shown in Fig. 1. Two 4BA clearance holes for the terminals are drilled as shown at "A," and at points where the ends of the winding will come a pair of very small holes are drilled to enable the ends of the wire to be secured in the usual way by threading the wire in and out of the holes. Diametrically opposite to the terminal holes, two more holes, this time 4BA tapping

size, are drilled and tapped to take the pair of 4BA screws which secure the tube to the small ebonite base. The positions

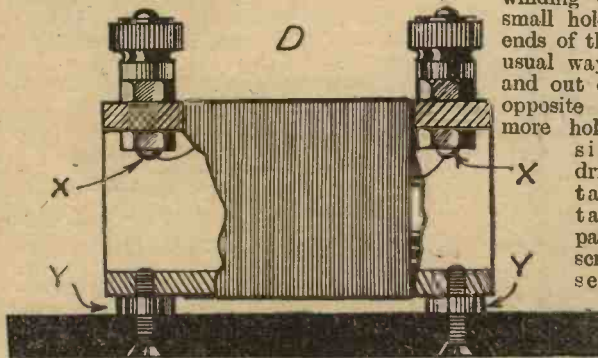

Fig. 3.—Sectioned view of the choke showing method of connection and spacing from the base.

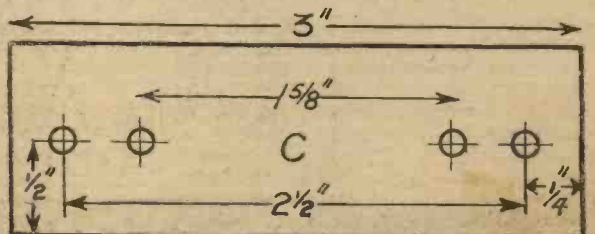

Fig. 2.—Drilling dimensions for the ebonite base.

# RADIO RAMBLINGS

## Seventy Stations

LAST week I referred to my tests with a new three-valve set, shortly to be described in PRACTICAL WIRELESS. Since writing those notes I have been giving the set a very complete test in the North of England. On an outside aerial, situated about twenty-five miles from the North Region transmitters, some seventy-two stations have been logged. Of course, these were not all heard in any one test, but the list was compiled in three or four "sittings." I know that it is considered somewhat old-fashioned to be keen on receiving signals from all over the globe, but I must say that it does fascinate me to hear strange voices and strange languages, even if I cannot understand them. And, despite all that is said to the contrary, the

## JOTTINGS FROM MY NOTEBOOK.

By "DETECTOR."

usual tests were applied, and it was eventually discovered that the detector valve was receiving a plate voltage of about 300, and the output valve, 320 volts.

### Rectifier Output

THE owner of the set was perfectly certain that my voltmeter was wrong, because he was using mains equipment which, he said, could not possibly supply the high voltages that were recorded. (Incidentally, I knew the meter to be perfectly accurate.)

As a matter of fact, the mains transformer was rated to give 200 volts at 100 milliamps, and was used in conjunction with a metal rectifier (voltage doubler circuit), of which the output was 250 volts at 60 milliamps. It was, therefore, calculated that the maximum available H.T. voltage would be in the region of 200, since there would be a certain amount of voltage drop across the smoothing choke and also across the bias resistance. This would have been the case if the current consumption had amounted to 60 milliamps, but actually it was only about 30 milliamps. In consequence, the voltage rose a good deal above the anticipated figure. To make this point clear, I drew out a typical "voltage regulation" curve like that shown in the accompanying drawing, Fig. 1. The curve shows the voltage available from a rectifier under varying conditions of load. The curve given refers in particular to a metal rectifier with a maximum rated output of 250 volts at 60 milliamps, but very similar curves could be drawn to apply to any type of rectifier, either metal or valve.

expense of a new rectifier, or the trouble of re-winding the transformer?" I explained that it could, by connecting a suitable resistance in series with the positive H.T. lead, or, better still, by putting a resistance in parallel with the supply. The latter method is far more satisfactory, since it actually reduces the voltage across the output terminals of the rectifier, whilst the other only cuts down the voltage passed on to the valves, and so leaves the rectifier to supply a larger voltage than that for which it was designed.

The proper method of fitting the resistance is shown in Fig. 2. As it is required to consume 30 milliamps at 250 volts, its value can be found by applying our old friend, Ohm's Law, thus,  $R = E/C$  or  $250 \div .03$  amps, which is equivalent to about 8,000 ohms. The resistance will have to deal with  $250 \times .03$  amps, or  $7\frac{1}{2}$  watts, so it must be one of the 10 watt power type.

### L.S. Power Handling Capacity

WHEN choosing a loud-speaker for use with a powerful receiver, do not forget it will have to handle the full output of the last valve. It is advisable to obtain a speaker having a power handling capacity equal to about one and a half times the "undistorted output" rating of the last valve in order that there shall be no overloading under any circumstances. As the "undistorted output" of a mains super-power valve, such as the Cosor 41 MXP, is 2,000 milliwatts, a speaker for use with it should be capable of dealing with something like 3,000 milliwatts, or 3 watts, if you prefer it that way. Some speaker manufacturers do not publish definite figures regarding their products, but they will always supply them on request.

### Earth Connections

WE have previously stressed in the pages of PRACTICAL WIRELESS the great importance of a really good earth lead, but I continue to run up against cases of unsatisfactory earth connections. If you are in any doubt as to whether your earth is functioning properly you can test it in two seconds by touching the earth terminal, or the earthed bush of a variable condenser on the front of the panel, with a moistened finger. If this causes any change in the loud-speaker volume you can rest assured that the earth is definitely at fault.

(Continued on page 664.)

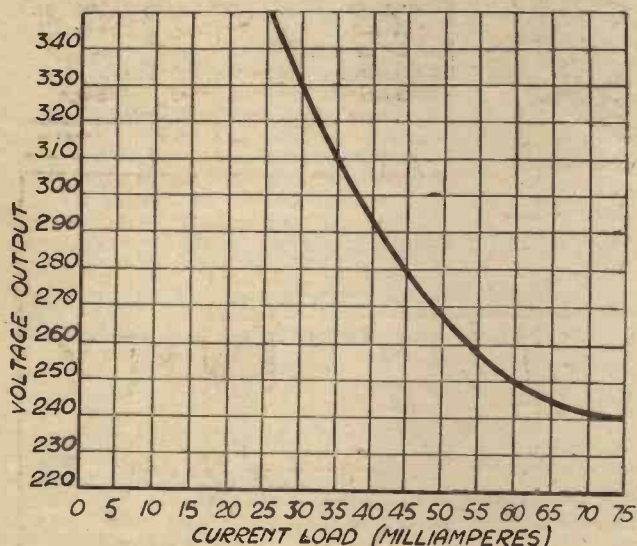

Fig. 1.—A voltage regulation curve of a mains rectifier.

number of stations that can be received at good strength and quality is a definite criterion of a set's performance.

### Too Much High-Tension

I SEEM to be spending all my leisure (?) time these days tracing faults in A.C. receivers. Only the other day I was asked to look at a home-made Detector-L.F. all-A.C. set which, for some reason or other, was dreadfully unstable. Reaction control was fierce, so that oscillation started with a loud "plop" as the condenser was rotated. There was also a considerable amount of overlap in the reaction control, with a result that after reaching the point of oscillation, the reaction knob had to be turned back through several degrees before oscillation could be checked. But even when the set was tuned in there was a constant "whine" in the speaker, which suggested that things were not as they should be. Of course, the

### Reducing the Voltage

AFTER convincing the set owner that the H.T. voltage was definitely too high, the next question that arose was "Could it be reduced without going to the

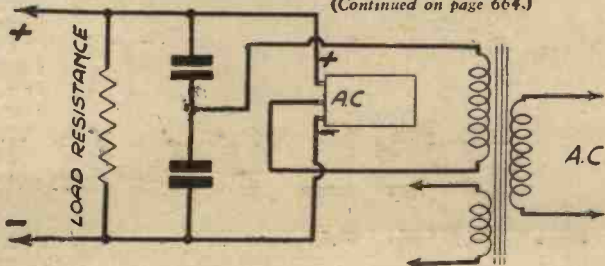

Fig. 2.—Reducing the output of an eliminator.



**NOTE THE PRICE...**

The famous 'Triumph' Transformer suitable for 1st or 2nd stage of L.F. amplification ratio 3½-1. Price 5/-

7-1 model. Price 10/6

Victory Transformer, 3½-1 ratio. Price 7/6

From all dealers or direct

**BRITISH GENERAL**

Manufacturing Co., Ltd.,  
Brockley Works,  
London, S.E.4.

*An Essential Book for*

*The Wireless Amateur*

THIS book is written for the amateur who desires a fuller knowledge of his subject. It will enable you to attempt research and experiments which before were far beyond your powers. The author has the gift of explaining abstruse subjects in a simple fashion. Fully illustrated.

**The MATHEMATICS of WIRELESS**

By **RALPH STRANGER** 5/-

Obtainable at all Newsagents and Bookstalls, or by post 5/3 from George Newnes, Ltd., 8-11, Southampton Street, Strand, London, W.C.2.

*a Gift Suggestion*  
**Amazing Selectivity**  
**— ALL stations clearly**  
**and without overlapping**

**AND NO ATMOSPHERICS**

Improve your radio beyond all recognition for Christmas! Hear all stations—even those you have never heard before—clearly and distinctly... with whatever degree of volume you please... without distortion of any kind... without annoying static noise. You can with a Cop. It is

**7 ACCESSORIES IN ONE**

—all combined in a well-made, super efficient aerial lead-in and automatic cut-out which—even during the worst of storms—will enable you and yours to listen in safety (backed by a £100 F.B.E. Insurance Policy against damage by lightning). What gift would be more appreciated by your radio friends. A Cop is just the thing you need, too! Get one TO-DAY—from your local Radio Dealer, or post free, direct from the makers:

**PRESSLAND**

**AERIAL CONTROL**

CLIFFORD R. PRESSLAND (SALES) LTD.,

84, Eden Street,

KINGSTON-ON-THAMES.

PRICE **2/6**

**COP**

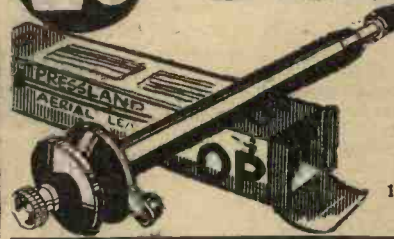

Prices:  
6 in. 2/6  
9 in. 3/-  
12 in. 3/6

**£100**  
**FREE**  
**INSURANCE**  
**AGAINST**  
**LIGHTNING**

Scientific

*Give yourself*

**SUPER SELECTIVITY**  
*this Christmas*

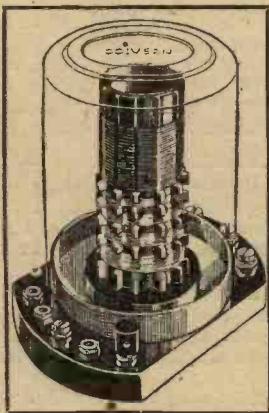

**COLVERN**  
T.D. COIL - - 8/6

Super selectivity is vitally necessary under present-day broadcasting conditions. Give yourself a Colvern T.D. Coil for Christmas and bring in those foreigners separately. The Colvern T.D. Coil is completely screened and incorporates tapped aerial coupling and reaction. Four alternative aerial tappings are arranged as sockets with a wander plug.

The first two tappings give aerial couplings similar to those normally employed but with greatly increased selectivity. Numbers 4 and 5 give a high degree of selectivity with weak aerial coupling suitable for use in a swamp area. There is no break through on the long wave-band from B.B.C. stations. Suitable for detector L.F. type of screen grid receivers.

• *with a*

**COLVERN T.D. COIL**

**COLVERN LIMITED**

**MAWNEYS RD.,**

**ROMFORD,**

**ESSEX.**



## MAINS UNIT KITS

Build your own Mains Unit, and be sure of getting the exact output to suit your receiver. This can be done quite easily with the Heayberd Assembled Kit. All components are assembled and mounted on the base. YOU simply do the wiring, following the blue-print and instructional booklet provided. It's an interesting job; you get to know your own Unit thoroughly, and it is cheaper.

**MODEL C. 150 ASSEMBLED KIT.**  
Alternative Outputs: 25 ma. at 120v.  
or 150v.

Tappings: 40/110v. Var. S.G. 76/-  
60/130v. Var. and 150v. fixed.

Including: Heayberd Transformer, Choke, 16 ml. Condensers, Westinghouse Rectifier, Wire-wound Potentiometers, Resistances and Fuse. Complete in neat Metal Case—ready for wiring.

# HEAYBERD

MONARCH OF THE MAINS.



## Post Coupon

for Heayberd handbook on Mains Working

I enclose 3d. stamps for New Handbook of Mains Equipment. Packed with Technical Tips, Service Hints and diagrams

Mr. \_\_\_\_\_  
Address \_\_\_\_\_

P.R.A.

**F.C. HEAYBERD & Co.**

10 FINSBURY STREET, LONDON, E.C.2  
One minute from Moorgate Stn

## MAKE YOUR OWN ELIMINATOR WITH A GUARANTEED "VARSITY" H.T. UNIT KIT.

Please state Mains Voltage when ordering.

KIT "A," for the average 2 or 3 valve set 35/-  
KIT "B," for small 4 or 5 valve sets ... 45/-  
KIT "C," as specified Oct. 22nd, Page 221 ... 65/-  
TRICKLE CHARGER (see Nov. 19th issue) ... 17/6  
KIT "D," 2, 4 or 6 volts. 25 amp. ... 21/-  
KIT "E," do. 5 amp. ... 21/-  
KIT "F," do. 1 amp. ... 25/-

All above for A.C. Mains. 100-250 volts. 40-60 cycles. Westinghouse, T.O.G. and Dutilier parts included, and each KIT is guaranteed to give successful operation. BLUE PRINT and FULL INSTRUCTIONS with every KIT.

**TRANSFORMER and Smoothing CHOKES.**

KIT "G," as specified Oct. 22nd, TRANSFORMER PARTS 10/-  
KIT "H," as specified Oct. 22nd, CHOKES 6/-

We cater for the man who makes his own. Impossible to list everything we stock: Foil, Empire Tape, Sleeving, etc.

ORDER DIRECT. CASH, C.O.D. (pay postman) or H.P. FROST RADIO COMPANY, 21, RED LION ST., LONDON, E.C.1

**LOUD SPEAKERS REPAIRED. 4/-**  
(Blue Spot a Speciality, 5/-)

Transformers 4/-. All repairs magnetised free. Eliminator Repairs quoted for. 24 Hours Service. Discount for Trade. Clerkenwell 9069.  
E. C. MASON, 44, EAST ROAD, LONDON, N.1.

## Radio Ramblings.

(Continued from page 662.)

### No Aerial

**S**PEAKING of earth connections reminds me of another point. With a reasonably sensitive receiver it is possible to obtain quite good results from the local stations by dispensing with the aerial entirely and transferring the earth lead to the aerial terminal. You might find this tip very useful if at any time you wish to take the set into another room some distance away from the aerial lead-in. Try it, anyway.

### Raindrop "Atmospherics"

**A** NEWLY-FLEDGED wireless enthusiast of my acquaintance came round to my house the other evening and begged me to have a look at his set, which was making "a most peculiar noise." I went along in the rain and found the noise was rather like what one would expect to hear if a shower of pins was dropped on to a bass drum. I recognised the sound right away (I had heard it before) as being caused by rain falling on the aerial wire, and proved this

TINFOIL PACKED  
BETWEEN WINDING  
AND BAKELITE  
MOULDING

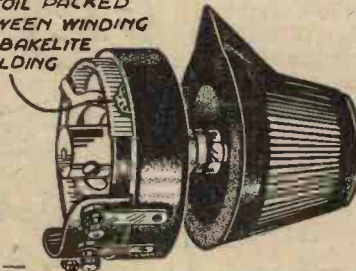

Fig. 3.—

A simple method of repairing a potentiometer.

by disconnecting the lead-in. Perhaps you have experienced the same thing yourself. As a rule the noise is heard only when thunder is hanging about, and is due to the raindrops being charged with a minute amount of positive electricity acquired from the upper atmosphere. The charge leaks away to earth via the set, and so causes the peculiar noise to be heard. I don't quite know why it should be so, but this form of interference appears to be much more noticeable with some aerials than others. I remember that it was very troublesome with an aerial I had at a house where I lived a few years ago. There was apparently no cure, but things were improved very considerably by changing the bare aerial wire for a length of insulated cable.

### Sparks across A.-E. Switch

**B**Y the way, it is surprising what a hefty charge can be built up on the aerial if it is not earthed. I remember one late summer afternoon returning home in a thunderstorm and rushing to switch my aerial over to "earth." On closing the contacts (it was an open D.P.D.T. switch screwed on to the window frame) I was surprised to see, and hear, two or three sparks jump between the blades and springs of the switch. Out of curiosity I opened and closed the switch four or five times, and obtained no less than three distinct spark discharges.

### Buzzing Transformers

**W**HEN using an A.C. receiver or eliminator it often happens that a buzz is heard which cannot be traced to ordinary hum. It is caused by the vibration of the core laminations in the mains transformer or smoothing choke. The correct way of curing it is to tighten up the core clamps,

but this is not always possible in a commercial mass-produced instrument, because the clamps are attached by rivets instead of the more customary bolts and nuts. When the clamps are riveted the simplest and best cure is to pour a small amount of shellac varnish over edges of the core. This will slowly soak in and set hard, leaving the core quite solid.

### A Potentiometer Repair

**I** HAVE a three-valve mains set with a volume control in the form of a potentiometer which serves to regulate the voltage to the screening grid of the S.G. valve. The set has been in use for nearly two years, but I found to-day that if the potentiometer knob was turned past a certain point the set became dead. Obviously the potentiometer was wrong, but I could see no break in the very fine windings. There wasn't another suitable potentiometer on hand, so I could see I should have to repair the old one somehow or other. So I turned the knob slowly until the break was reached, made a small pencil mark on the winding track and removed the potentiometer from the set. It was only a matter of minutes before it was completely repaired by packing a piece of tinfoil from a cigarette packet over the place where the break had been located. By chance the idea may be of use to you, so I give a sketch (Fig. 3) to show how the repair was effected.

### Compensated M.C. Speakers

**S**OME time ago I mentioned in these columns that pairs of compensated moving-coil speakers were now being made almost as cheaply as the single instruments. Last week I was able to test a pair of balanced speakers made by the "Rola" concern, and selling at £2 12s. 6d. The results were fine, and I should think these speakers represent one of the finest value-for-money examples in the radio market.

### A Moving Coil "Baby"

**A** NOTHER example of excellent value is the Celestion "Soundex" permanent magnet moving-coil unit which retails at 27s. 6d. The cone is only about 5ins. in diameter, but when mounted on a suitable baffle it gives any amount of volume—certainly ample for most domestic requirements. Surely no amateur can now say he cannot afford a moving coil!

### Alterations at Toulouse

**I**F you are a burner of the midnight oil you will probably have heard the test transmissions of Radio Toulouse on a power of 60 kilowatts. The tests are being carried out after midnight on the same wavelength as the regular 8 kilowatt transmissions (385 metres) and are being well received in the North of England. I have heard the test transmissions on two occasions, and they came in at great strength. At the same time, I should never have guessed that the power had been increased nearly eightfold, as there is still a noticeable amount of fading. Requests for reports are made in three or four languages, including English.

### More Stations for Germany

**I** HEAR that two new German stations, each using a power of 60 kilowatts, are to come "on the air" before long. The new transmitters are situated in Munich and Berlin, respectively. So far as I can gather, no official wavelengths have yet been allotted.

(Continued on page 668.)



COMMENTS ON COMPONENTS

LAMPHOLDER PLUG

QUITE a number of modern mains instruments are fitted, at the end of the flex, with an ordinary lamp-holder adaptor. This is intended for insertion in an ordinary electric-light fitting in place of a bulb, and is quite suitable where the consumption of the apparatus is small. In this category is found such wireless apparatus as trickle chargers, small eliminators, etc. Unfortunately, the nearest lamp-holder is not always conveniently situated with respect to the wireless set, and, therefore, it becomes necessary to

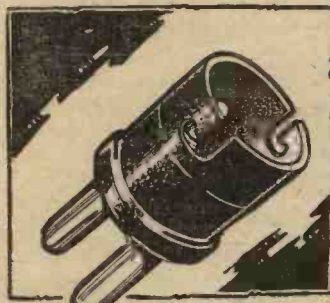

The lampholder plug.

use a long trailing length of flex, or buy a two-pin adaptor to insert in the nearest power point, which is invariably on the skirting. The new Ward & Goldstone lamp-holder plug, which is illustrated, is designed to overcome this trouble. It consists of a bakelite moulding fitted at one end with standard 5-amp. type pins, whilst the other end is finished off as a lamp-holder. It may, therefore, be plugged into any 5-amp. power point, and the usual bayonet socket inserted in its end. As this little article only costs 7d. it will be found invaluable for providing interchangeability in the home.

NEW 2-VOLT MULTI-MU VALVE

THE Mullard Wireless Service Company first announced brief details of the P.M. 12V Battery Multi-mu Valve at Radiolympia, but the first supplies were rapidly absorbed by set-manufacturers, thus delaying the general release of this valve. Supplies are, however, now available to the public. The published characteristics of the valve are as hereunder:—

Filament Voltage	2.0V
Filament Current	0.15A
Max. Anode Voltage	150V
Max. Screen Voltage	90V
Mutual Conductance at Anode Volts, 150;	
Screen Volts, 90: Grid Volts, Zero:	0.75 mA/V

Smooth control of sensitivity can be obtained by varying the negative grid bias up to a maximum of 15 volts. This can conveniently be done by means of a potentiometer of 20,000 to 50,000 ohms, connected across the 15-volt battery, which also supplies grid bias to the low-frequency portion of the receiver.

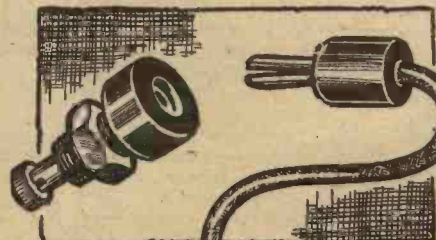

The Cliz socket which was described on this page last week. The neat proportions may be seen from this illustration, which is nearly twice the actual size

deck," if preferred. Its inductance value is 198,000 microhenries, and it will give a smooth choking effect, without peaks from 100 to 1,750 metres. Price is 2s.

HARLIE PICK-UP

THE Model 36 Pick-up, manufactured by Harlie, Ltd., is an extremely interesting instrument. It is of the complete volume control-tone arm type—that is to say, the assembly is complete and only requires to be mounted on the motor-board of a gramophone to be ready for use. The whole assembly is finished in brown bakelite, no metal being anywhere visible. The pick-up head is fitted with a swivel movement, permitting it to be rotated for needle insertion. The tone-arm is fitted with a splendid ball-bearing movement so that perfectly smooth movement is imparted to it. An ingenious twin-spring, weight-relieving movement is fitted at the rear of the tone-arm support and an adjusting screw is fitted to this so that any degree of weight may be imparted to the pick-up head. The very minimum of wear is therefore given to the record by suitably adjusting the weight so that it keeps to the grooves on all normal records. The magnet of the pick-up is of cobalt-steel, with pole pieces of high permeability alloy. The needle movement is exceptionally free, and an adjustable damping device is fitted. On test, the reproduction was of a very high order. Bass notes were reproduced in very fine proportion, showing that the characteristics of the pick-up have been designed to compensate for the lack of bass in the recording processes. There was no screechiness on the top notes, and with every make of record tested the response could be described as straight-line. The sensitivity seemed above the average, and the volume control, which is fitted on the rear tone-arm support, had to be frequently employed to avoid overloading the input valve. At the modest price of 27s. 6d. this is truly a "de luxe" instrument.

10-1 COUPLING UNIT

A HIGH stage gain is often very useful, and the highest transformer is usually of a ratio of 7 or 8 to 1. Messrs. Telsen have produced a special 10 to 1 unit which consists of a transformer plus a resistance and condenser. The anode resistance has a value of 25,000 ohms, whilst the coupling condenser is of .5 mfd. The transformer itself is of the high permeability nickel alloy type with a primary inductance of 40 henries. The characteristics of this component are ideal for modern receivers, having a rising curve at the bass end of the scale to bring out the low notes, and a falling curve at the higher end of the musical scale to cut down heterodyne whistles, needle scratch, etc. Obviously one stage of L.F. amplification employing this coupling will be almost as good as two ordinary stages, and at the same time will give a splendid response. The price is only 12s. 6d.

FUSED MAINS PLUGS

WITH the increased use of all-mains sets, there is a demand for some form of "safety" plug. J. A. Crabtree & Co., Ltd., have produced some very novel and useful plugs with china base and bakelite upper portion. The pins are of standard size and are obtainable for 5 or 15 amp. wiring sockets. When using, for instance, a wireless set on a 15 amp. circuit, the fuse in that circuit is much too large for the receiver and does not, therefore, provide a safety device for it. These fused plugs are designed to overcome this drawback, and are equipped with a fuse in each pole. In the 5 amp. size the fuse is rated at 2 amps., and in the 15 amp. size, 5 amp. fuses are fitted. The fuse is laid in asbestos cord, and the centre of the plug is hollowed and contains a reel of spare fuse wire. The result of this is that small domestic appliances such as toasters, irons, wireless eliminators, etc., may be plugged into the power socket of the room, and in the event of short circuits in the apparatus or leads, only the fuse in the plug will blow, leaving the mains fuses intact. This point is of inestimable use to residents in out-of-the-way districts, or even the town dweller, on a Sunday, when no new mains fuse wire is obtainable.

# What we Found..

BULGIN SCREENED "MIDGET" H.F. CHOKE

BUILT on the lines of the Bulgin standard screened chokes, this model is specially designed for space economy. Somewhat squat in shape, it is conveniently mounted on the underside of the chassis with terminals projecting through, or it can be mounted "on

GOODMAN M.C. SPEAKERS

THE illustration shows one of the new Goodman speakers which are now being produced for the public direct. The "Deadnought" is a high class permanent speaker designed on de-luxe lines, and selling at 30s. 6d.



The Goodman "Deadnought" moving-coil speaker.

The magnet is of cobalt-steel with a very high flux density, giving a high degree of sensitivity and so enabling it to be used with small receivers. The cone is made of a special treated material known as "Veratone," giving a very fine response curve. A multi-ratio output transformer is included with this model and the entire instrument is finished in glossy cellulose.

MULLARD VALVE GUIDE

THE latest valve guide issued by the Mullard Company consists of a 96-page book. Sixty pages are devoted to the various valve types, on which, in addition to the curves, all working data is given. This data is extremely complete, giving, in the case of output valves, the Optimum load, a very valuable feature. A novel feature of these pages is the provision of a clear space headed "Notes," upon which the

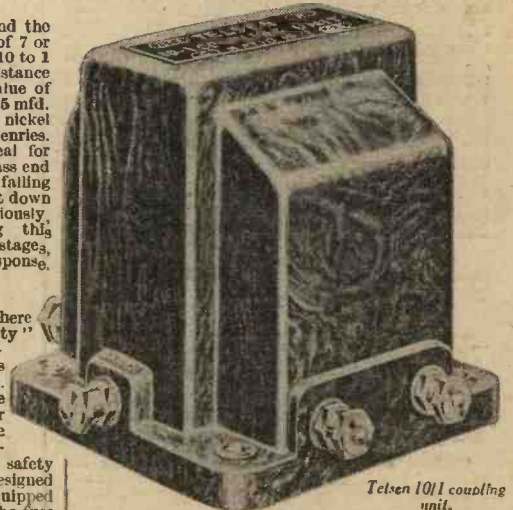

Telsen 10:1 coupling unit.

reader may enter any suitable information relating to the valve. Seven pages are devoted to a "Technical Appendix," in which are copious notes on Automatic Grid Bias, The Multi-mu Valve, Anode Decoupling, Choosing Resistances, Choosing an Output Transformer, Choosing Fixed Condensers, Operating Pentodes, etc. Lists of the principal commercial receivers are given, showing the appropriate Mullard valves, and four clear pages are supplied for notes. This is a handbook which every listener should obtain. There is no charge for it, and a postcard to the Mullard Company will bring one by return.

Tune in  
on  
this



## NEW WIRELESS INSTRUCTION

The I.C.S. Wireless Courses cover every phase of wireless work, from the requirements of the youth who wishes to make wireless engineering his career to the man who wants to construct a broadcasting set for his home, and, at the same time, to know how and why it operates and how to locate any faults that may develop.

No branch of industry has ever progressed as rapidly as wireless and the rate of progress is increasing. Only by knowing thoroughly the basic principles can pace be kept with it. Our Instruction includes American broadcasting as well as British wireless practice. It is a modern education, covering every department of the industry.

### OUR COURSES

Included in the I.C.S. range are Courses dealing with the Installing of radio sets and, in particular, with their **Serviceing**, which to-day intimately concerns every wireless dealer and his employees. The Operating Course is vital to mastery of operating and transmitting.

There is also a Course for the wireless salesman. This, in addition to inculcating the art of salesmanship, provides that knowledge which enables the salesman to hold his own with the most technical of his clients.

We will be pleased to send you details of any or all of these subjects. Just fill in and post the coupon, or write in any other way, stating which branch of Wireless interests you—the information you require will be forwarded at once.

—YOU MAY USE THIS COUPON—

International Correspondence Schools, Ltd.,  
Dept. 94, International Buildings,  
Kingsway, London, W.C.2.

Without cost, or obligation, please send me full information about the Courses I have marked x

- THE I.C.S. WIRELESS COURSES
- THE I.C.S. RADIO COURSES

Name .....

Age .....

Address .....

# Radio Christmas Gifts

Practical Hints on Choosing Practical Presents.

By "RADIOMAN"

BY no means the least of the many blessings that wireless has conferred upon mankind lies in providing what is, perhaps, the world's best solution to the perennial problem of choosing suitable Christmas gifts for one's friends and relatives! In these days when nearly everybody seems to be a wireless enthusiast, radio gifts are almost universally acceptable, provided that they are sufficiently well-chosen to enable the recipient to exclaim: "Just what I wanted!" with veracity as well as politeness.

The whole art of choosing thoroughly acceptable wireless gifts lies in finding out beforehand exactly what set, components, accessories or tools are really wanted, and are therefore likely to be of practical use to the person for whom the present is intended. A surreptitious but careful inspection of your friends' or

relatives' receiving outfits is the essential preliminary to successful Christmas shopping at the radio store! Have a look when they are not looking, and see what is lacking, or what parts of the installation could with real advantage be replaced by more efficient up-to-date components or accessories.

### Gifts to Suit Every Purse

One of the greatest advantages of radio gifts, from the donor's point of view, is that thoroughly useful wireless gadgets can be bought at any price from a few pence up to many pounds, so it is literally true to say that one can find a wireless Christmas present to suit every purse that contains any money! In this article I propose to offer a few practical suggestions which will help you to choose gifts from

(Continued on page 667.)





### RADIO CHRISTMAS GIFTS

(Continued from page 666.)

the somewhat bewildering assortment of innumerable devices of all kinds on sale at every radio shop.

Let us take the least expensive items first. Fuses, for instance. It is surprising how many receivers are devoid of any fuse for the protection of the valve filaments and batteries in the event of accidental short-circuits, etc. Different kinds of fuses, suitable for mains or battery sets as the case may be, and rated to "blow" at various currents from 50 or 60 milliamps upwards, can be purchased (complete with suitable holders) for a shilling or two. The fuses themselves, for replacement, cost only a few pence. Such an inexpensive gift as this may be worth pounds to the recipient if it is instrumental (as it easily may be) in saving valuable valves and batteries from destruction.

Some of the newer types of switches on the market are marvels of efficiency compared with many of the older ones. If any of your friends' loud-speakers give forth fearsome crackling or grating noises whenever the switches on the set are operated, the gift of one or two up-to-date switches of suitable types should be greatly appreciated—not only by the owner of the set but also by everyone who is in the habit of listening to it! When a set is used much by non-technical members of the household, indicator switches, with clear lettering showing the "on" and "off," or "long-wave" and "short-wave," or "gramo" and "radio" positions, are preferable to the plain types. Even the best switches are now relatively cheap, and for a shilling or two one can get a really excellent, quick-make-and-break switch of the simple "on-off" kind.

#### Cone-Adaptors and Dual-Range Coils

Anyone who has a cone-type loud-speaker that is inclined to rattle or "chatter" on loud passages of music, etc., would be pleased with the gift of one of the special cone adaptors that can be bought for a shilling or so. Passing on to rather more expensive presents, a dual-range coil of an efficient and reliable make is a gift that might be heartily welcomed by anyone who is at present using interchangeable plug-in coils. Very efficient screened tuners can now be obtained quite cheaply.

There are still many listeners who have not yet explored the short waves below 100 metres and investigated the possibilities of this fascinating branch of reception. If any such listeners are numbered among your friends, why not make them a present of a set of short-wave coils, if their receivers are of the kind that can be adapted easily for short-wave reception by the simple expedient of changing coils? Or, better still, give them a complete short-wave adapter or converter—bearing in mind, of course, that the superheterodyne type is suitable only for use with sets which contain one or more stages of H.F. amplification.

#### New Valves and Batteries

New valves often give a new lease of life to a set. Some of the modern types represent an enormous advance in efficiency on those of a few years back; and, in any case, valve filaments lose their emission after a time, so that every listener needs suitable replacements occasionally. If, therefore, you have a friend or relative whose set is hampered by worn-out or

(Continued on page 668.)



**Dubilier**  
**Condensers**  
 chosen by  
**KOLSTER-**  
**BRANDES**  
 for  
**dependability**

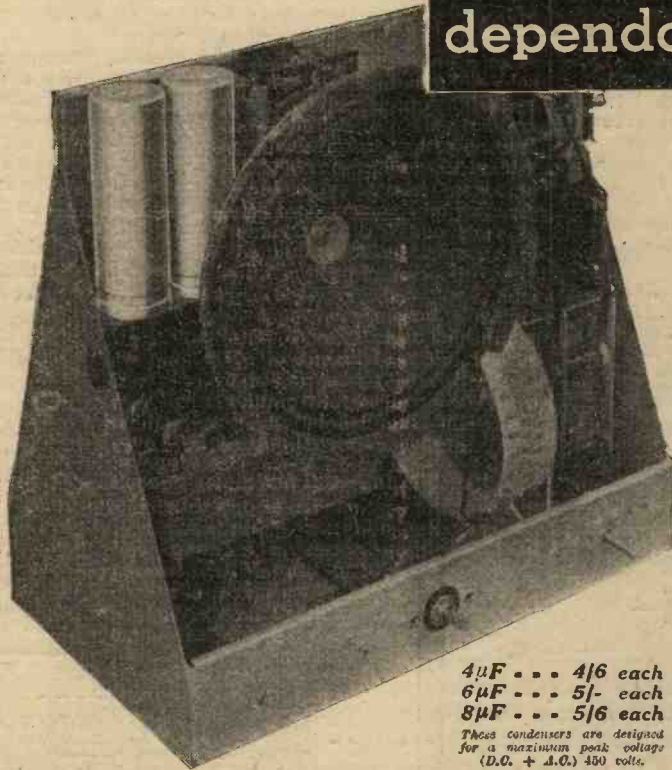

4 $\mu$ F . . . 4/6 each  
 6 $\mu$ F . . . 5/- each  
 8 $\mu$ F . . . 5/6 each

These condensers are designed for a maximum peak voltage (D.C. + A.C.) 450 volts.



The well known firm of Kolster-Brandes exercise great care in the selection of the Condensers used in their receivers. The fact that they are using Dubilier Condensers in ever-increasing quantities is sufficient proof of their dependability and consistent performance. Whatever type of Condenser you require, you will find it in the Dubilier range. The Dubilier Dry Electrolytic Condenser illustrated above is specially designed for use as a smoothing condenser in mains radio apparatus.

# DUBILIER

## CONDENSERS

E19

DUBILIER CONDENSER CO. (1925) LTD.  
 Ducon Works, Victoria Road, North Acton, London, W.3

Distributing Agents for Irish Free State: KELLY & SHIEL LTD., 46/47 Fleet Street, Dublin, C.4

**Realise the Importance  
OF YOUR RESISTANCES**

**ERIE**  
GRID-LEAKS and  
**RESISTORS**



As half the construct-  
or's troubles are due to unstable  
grid leaks and resistances,  
let ERIE carry the load. They  
are guaranteed in every res-  
pect. Safe, silent, stable, and  
impervious to humidity  
fluctuations, they will  
solve one of your biggest  
problems as they have  
solved the similar prob-  
lems of the leading Radio  
Manufacturers.

All values, one, two,  
three and five watts.  
50 ohms to 4 megohms

**1** PER WATT  
in all values  
50 Ohms to  
5 Meg.

**Mr. Ohms**  
The sign of Eerie Resistors

Eerie Resistors carry an unqualified  
GUARANTEE against breakdown.

Write for leaflet

The Radio Resistor Co., 1 Golden Square,  
London, W.1.

**MOUNT YOUR  
TERMINALS NEATLY  
ANYWHERE—**

With the Belling-Lee  
Bakelite Terminal  
Mount, terminals may  
be mounted anywhere,  
anyhow—vertically or  
horizontally. On the  
baseboard or screening  
box, the window ledge,  
wall or skirting board, etc.

An exceptionally neat bakelite  
moulding designed to take  
two terminals of any make,  
particularly suitable for our  
"B" Type Terminal.

No. 1039 8<sup>D</sup>.

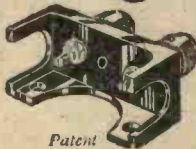
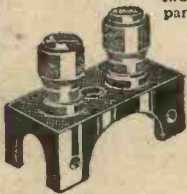

Write for complete list  
of Radio Connections.

Patent

**BELLING-LEE**  
FOR EVERY RADIO CONNECTION

Advt. of Belling & Lee, Ltd., Cambridge Arterial Road,  
Enfield, Middlesex.

**RADIO CHRISTMAS GIFTS**

(Continued from page 667.)

inefficient valves, you may be sure that new ones will form a welcome gift, provided, of course, that they are chosen to suit the set and its power supply. In the case of a battery-driven set, it is especially important to choose valves whose voltage and current ratings are within the capabilities of the batteries. For instance, anyone who is in the habit of using standard-capacity H.T. batteries may not thank you very fervently for a super-power valve that fairly feasts on milliamps!

The new tone-control transformers now on the market afford a means of greatly improving the performance of many existing sets and amplifiers. These transformers can be fitted quite easily, as a rule, in place of an ordinary transformer or R.C.C. unit, so they form widely-acceptable gifts. The transformer itself and a variable resistance or potentiometer suitable for controlling the tone of reproduction can be bought for about a guinea. A gramophone pick-up makes an excellent present for any listener who has an ordinary gramophone and a valve set with loud-speaker. Most sets which contain one or more stages of L.F. amplification can be adapted quite easily for gramo-radio work. One can give anything from a pound up to several guineas for the necessary equipment.

For those who own battery-driven receivers, new H.T., L.T., and G.B. batteries

provide a good solution to the Christmas-present problem. Anyone, for instance, with an old accumulator that is failing to hold its charges properly will welcome one of the latest types of accumulator replete with up-to-date improvements. Even the best makes are fairly inexpensive nowadays, ranging in price from a few shillings upwards according to type and capacity.

**Loud-speakers and Tool Kits**

A new and better loud-speaker is a gift that is sure of a hearty welcome. The model chosen should, of course, be of a type suited to the output from the set with which it is to be used. A small set, for instance, may not supply a sufficiently powerful signal to operate, say, a moving-coil speaker to the best advantage. Anyone who has a self-contained receiver or radiogram with built-in loud-speaker would almost certainly be glad of an additional loud-speaker to be used on the end of extension leads to rooms other than that in which the set is installed. Most sets with built-in loud-speakers can be adapted quite easily for the addition of an external speaker. Suitable materials for fitting-up loud-speaker extensions to different parts of a house form a useful gift. The necessary wiring, wall-jacks, loud-speaker plug, etc., can be bought for a few shillings, while a little extra outlay will cover the cost of a remote-control arrangement for switching the set on and off from a distance.

**RADIO RAMBLINGS**

(Continued from page 664.)

**Ordinary Transformers for P.P.**

THE push-pull system of amplification has frequently been advocated in these columns, and probably many readers would give it a trial were it not for the fact that new and special transformers had to be bought. As a matter of fact, however, it is possible to build a push-pull amplifier making use of ordinary L.F. transformers and a centre tapped output choke. The connections are shown in Fig. 4. Any ordinary L.F. transformers having a ratio of about 4.1 can be used, provided the

reasons for the great increase in power of Leipzig is that it is hoped to make possible reception from the Fatherland by Germans living outside their own country. Judging by the strength at which the station is being received in this country, it would appear that the results are highly satisfactory.

**Wavelength Check**

THE Brussels checking station of the International Broadcasting Union has recently issued another of its monthly graphs which are drawn out to show how closely the European stations have adhered

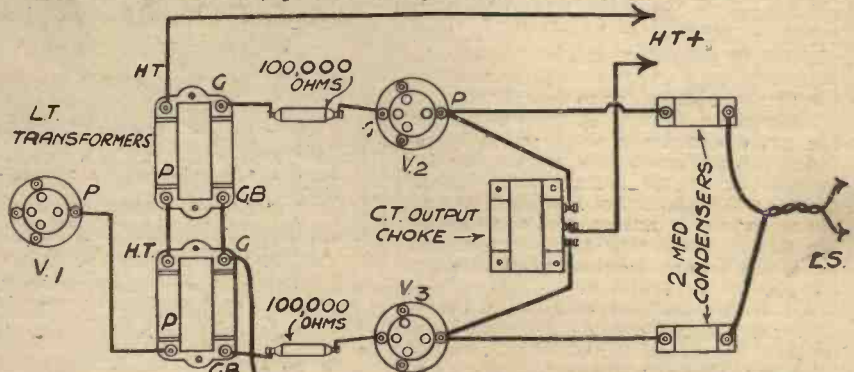

Fig. 4.—The method of making up a push-pull stage from ordinary components.

anode current consumption of V1 does not exceed 3 or 4 milliamperes. Valves V.2 and V.3 should be small power-valves of the 220 P class. If a centre-tapped output choke is not available, two ordinary L.F. chokes can be used in series. The loud-speaker should be either a high-resistance balanced armature one or a moving coil with medium ratio transformer.

**Leipzig—High Power**

CONTRARY to previous denials by the German broadcasting authorities, it is now understood that one of the principal

to their allotted wavelengths. The latest one, which refers to the month of October, shows what may be regarded as a fairly satisfactory state of affairs. Apparently the worst offender, as regards "wave wandering," was Bremen, which somehow managed to slip from its own frequency of 1,121 kilocycles right down to Bari's frequency of 1,112 kilocycles and back again no fewer than six times during the month. Barcelona also wandered a good deal, but fortunately did not cause any interference.



# Practical Letters

from

## Readers.

The Editor does not necessarily agree with opinions expressed by his correspondents

### Article on a Cheap Portable Set Wanted

SIR,—I would like to add my plea to that of "Portability," of Felixstowe, in last week's PRACTICAL WIRELESS. I have not yet seen a good portable set described in any journal, and I am sure there are many others who would wish to see in your paper instructions for constructing a cheap and efficient portable set. May I add my congratulations to the many others already published?—JOHN B. GIBSON (East Preston).

### Entertainment Side of Wireless

SIR,—Permit me to disagree with your Northwood reader, who in a recent issue praises you for not having articles about radio stars and studios. It takes all sorts to make a world, and a paper should cater for all readers. In buying your paper, I praise your size, I applaud your value, and the technical side is good. But, personally, I should like to see more space given to the entertainment side of broadcasting—since there are times when I want to read your paper, but do not want to fiddle with my set. I feel sure you will appreciate this criticism. Your paper gives value, but as yet it does not give the best value, because it does not cater for all tastes.—WILL EVANS (Paddington).

### A Satisfied Reader's Suggestions

SIR,—First, please allow me to congratulate you for your publishing PRACTICAL WIRELESS. I have been reading wireless papers this last ten years. I have over 1,000 books in my den, but I feel you have struck a different style altogether, in fact, a style that there is room for. Practical, clear, and interesting. May I suggest a contents index on your front page so that one can find special articles by glancing at the covers? I would also suggest more mains work in plain talk. Wishing you every success.—J. AUCKLAND (Leeds).

### The Crystal Set Is Not Dead?

SIR,—If your journal keeps to the gadgets and wrinkle idea with, of course, something in the way of a good set now and then, it will be just what is wanted. There must be dozens of small extra attachments to sets: viz., volume controls, both for speaker and set; extra H.F. units, also L.F. units; and the crystal set is not dead yet, although the various journals seem to think so. I do not think myself that it has been given a chance to show its best yet, and there must be thousands in use. If

they could only be made to give more volume by better arrangements of coil and wiring, what a jump there would be in their use. I am writing this, not because I am tied down to the crystal, for I have an 8-valve super-het., but because there are a great many people that cannot go to the expense of valves and batteries. Well, I hope you will take this in the spirit it is written, and that your paper goes on in the way it has begun, and so pave the path to prosperity.—JOHN H. WEBLE (Leeds).

### A Satisfied Reader's Suggestion

SIR,—Knowing that you have been overwhelmed with congratulations, I hesitate to add mine, but the stuff you continue to give us is so good that you will have all your readers wanting, "two Wednesdays in each week." I am one of your thoroughly satisfied readers, and yet—why have you discontinued your "wireless shorthand" panel? I bought a special book and started pasting in my collection, and then, full stop! Again, I am one of the many thousands who still cling to the det., 2 L.F. type, which, though perhaps not up to modern standard, gives good

CUT THIS OUT EACH WEEK

## DO YOU KNOW?

—That one kilowatt is equivalent to 1.34 Horse Power.

—That one metre is equivalent to just over three and a quarter feet.

—That the valves used for transmitting get so hot that a special reservoir is used at the station to supply water for cooling purposes.

—That speech is the best subject for testing the high note response of a receiver and speaker.

—That all mains receivers should be well ventilated as the mains valves get very hot and some components are wax-filled and may be damaged by the excessive heat which is generated.

—That sal-ammoniac, soda, etc., will improve the earth connection if a quantity is buried beneath the wire.

—That variable condensers used for short-wave work should have a pig-tail connection for the moving plates.

—That accumulators may be damaged by over—or under—charging.

### NOTICE

The Editor will be pleased to consider articles of a practical nature suitable for publication in PRACTICAL WIRELESS. Such articles should be written on one side of the paper only, and should contain the name and address of the sender. Whilst the Editor does not hold himself responsible for manuscripts, every effort will be made to return them if a stamped and addressed envelope is enclosed. All correspondence intended to the Editor should be addressed: The Editor, PRACTICAL WIRELESS, Geo. Neville, Ltd., 8-11, Southampton Street, W.C.2.

Owing to the rapid progress in the design of wireless apparatus and to our efforts to keep our readers in touch with the latest developments, we give no warranty that apparatus described in our columns is not the subject of letters patent.

results and we stick to it because conversions and scrapping is too expensive, and no journal so far has given us a true conversion without scrapping, which could be achieved with a modest outlay. Now, Mr. Editor, could you not continue leading the way by obliging with a good H.F. conversion (not S.G.)?—J. WOODLEY (Llanfairfechan).

### More Congratulations

SIR,—I am writing these few lines in appreciation of your journal, which I have taken since the first issue. I think it is the best wireless weekly we have yet had, and I have been a reader and constructor for the past eight years, and I must say that your paper is the best threepenny worth I have had; it keeps more to the practical side of wireless, which is easier for the amateur to understand. That is what we want, instead of too much theory which the ordinary listener cannot grasp at first. Give us more practical illustrations with simple explanations, and then your paper will have an increasing circulation. I pass all my issues on to friends to spread the good news, and everyone speaks well of it.—CHARLES HUDSON (Shildon).

### Another Satisfied Reader

SIR,—I have just purchased my first copy of PRACTICAL WIRELESS, and have already put into practice one of your conversion schemes, namely "Band Pass Conversion," on page 398. I have a Cossor Melody Maker No. 234, and bought a Formo pre-set condenser. I screwed this on the outside of cabinet just below aerial and earth terminals, and bored two holes through the side of cabinet, wiring up condenser to set, according to your diagram. The result is astonishing, the selectivity has been increased greatly, and the loud-speaker is greatly improved, the only difference being that tuning has to be done slowly and finely. Thanks for your hint and splendid paper. You can put me down as a regular reader.—STANLEY NORRIS (Dundee).

### A. C. Valves: "Hymn of Praise."

SIR,—I must thank you for your reply re running last valve off raw A.C. I have tried this out, and it is very satisfactory. My 2nd question concerned converting my present set from battery valves to A.C. valves, but I hardly think now it justifies the expense and possible trouble, as the amplification of the two valves is not comparable. Now for the Hymn of Praise. I must congratulate you on your paper, which improves as it goes along, and gets down to "brass tacks" without the need of a technician to explain matters.—H. MILLER (Barnsley).



## CROWDED OUT

These holly leaves were intended for the Direct Radio Christmas advertisement. The page however is so crowded with Christmas Gift suggestions for your friends and yourself, that no space is available. Read all about these exceptional bargains—

**TURN TO PAGE 655**

### Practical Letters from Readers

(Continued from page 669.)

#### The Croydon Radio Society

SIR,—I would like to make a plea that you devote some space in PRACTICAL WIRELESS to Radio Societies' activities. You see, with such a young and enterprising paper, it must inevitably reach many a wireless enthusiast who would want to discuss the interesting points raised in its pages, and he would find his local radio society ideal for this.

We feel that your journal could be a great friend to we amateurs struggling for the common cause, and this Society would be pleased to furnish you weekly with, say, 100-word reports of our meetings.

Doubtless, other Societies would be also, and so I look forward to hearing from you that we may have a small corner of your paper devoted to our efforts.—E. L. CUMBERS (Hon. Sec.).

#### Conversion Circuits

SIR,—I may be rather late in writing to tell you how I enjoy reading my PRACTICAL WIRELESS every week, and I can assure you that there is a standing order for it to be delivered every week. Candidly it's the first radio journal ever published both for the expert and novice. May I make a suggestion? Can you spare a valuable page on wirings, circuits for the home constructor, to allow him to convert his set into a Radio-gram? Then, say, following week hints on same, etc.; or weekly details of how to make a cabinet for a radio-gram. May I wish everything good and a long life to the PRACTICAL WIRELESS.—H. H. PUGH (Salford).

## A SIMPLE DEVICE—

## MAKE YOUR H.T. BATTERIES

last at least **2 YEARS**



Send to-day for an everlasting REACTO Rejuvenator, the amazing new device for restoring H.T. Batteries to their original voltage by feeding them with L.T. from only a spare accumulator, which needs no recharging once a year, also keeps your new H.T. at full capacity. Batteries with REACTO last at least two years! Giving louder, clearer tone. No corrosion. No H.T. crackle. Simple instructions. Money refunded, if after 14 days Reacto does not do what we claim. A British invention, British Made. Patent applied for.

POST FREE

**3/6**

## REACTO H.T. REJUVENATOR

Send P.O. for 3/6 only to-day. Obtainable only from the manufacturers:

**REACTO APPLIANCES LTD.**  
(Dept. X.2.), 28, Watling St., London, E.C.4

## TO SAVE YOU POUNDS

Scientific

## STAGGERING OFFER TO HOME RADIO CONSTRUCTORS

AMAZING 84/- SET for **3**

THE FAMOUS **SLEKTUN SCOUT S.G.3** "50 Stations" KIT

At a GREAT REDUCTION for Xmas



The famous "Slektun" Scout Screened Grid 5-valve Kit Receiver, already built by thousands of enthusiastic constructors all over the country and formerly sold at 84/- is now offered to YOU for 23.

The Cabaret Electric Co., Ltd., to commemorate the opening of a magnificent new branch at Vauxhall Bridge Road, are able to make you this amazing offer for a limited period only, having purchased a huge quantity. Earliest application for one of these splendid kits is strongly advised.

Every kit includes the exact components originally specified by the designer, and is supplied complete with baseboard and ebonite panel out to size and ready drilled, together with all necessary terminals, wire and flex, full-size blue-print and illustrated construction guide.

### COMPLETE KIT

includes the famous Slektun Super Transformer, Slektun Dual Range Coils, Oylton Ganged Condenser with Sector Vision Escutcheon, T.O.O. Fixed Condensers, W.B. Valve Holders and Switches. Ready Drilled Panel and Terminal Strip of "Permal" non-discolourable Ebonite. Baseboard Assembly covered with "Kondutite" metallic screening material. All necessary screws, terminals, connecting wire, wander plugs and flex.

This is a wonderful chance to secure this fine set in time for Christmas as a lasting gift to yourself and your family.

**CABARET ELECTRIC COMPANY, LTD.**  
182, VAUXHALL BRIDGE ROAD, LONDON, S.W.1  
and 238, High Road, Lewisham, S.E.13

★ Write for Leaflet To-day.

## WECO VALVES

Specified for the

"MIDGET TWO"

Valve and Base Complete. Each 5/6

**ELECTRADIX 80 PAGE ILLUSTRATED CATALOGUE**

1933 Edition NOW READY

Copy sent Post Free for 4d. stamps.

**ELECTRADIX RADIOS,**  
218, Upper Thames St., E.C.4.

### The SLEKTUN "SCOUT S.G.3."

Simpler than ever to build

**FREE** Blueprint and Illustrated Construction Guide combined. Very practical instructions for building this great set—the complete kit of which costs only 84/-. Write for a Free copy of the New Blueprint Guide, sending 3d. in stamps for postage.

Slektun Products Ltd., 21, Douglas St., Westminster, S.W.1

## HEADPHONES

as specified for the "MIDGET TWO"

Lightweight. Sensitive. **4/6** per pair with cords. 4,000 ohms. post paid. Quotations for KITS on request.

**A. W. HANBLING LTD.,** 46, Alfred Place, London, W.1

LET OUR TECHNICAL STAFF SOLVE YOUR PROBLEMS

REPLIES TO



If a postal reply is desired, a stamped addressed envelope must be enclosed. Every query and drawing which is sent must bear the name and address of the sender. Send your queries to The Editor, PRACTICAL WIRELESS, Geo. Newnes, Ltd., 8-11, Southampton St., Strand, London, W.C.2

QUERIES and ENQUIRIES by Our Technical Staff

The coupon on this page must be attached to every query.

SPECIAL NOTE

We wish to draw the reader's attention to the fact that the Queries Service is intended only for the solution of problems or difficulties arising from the construction of receivers described in our pages, from articles appearing in our pages, or on general wireless matters. We regret that we cannot, for obvious reasons—

- (1) Supply circuit diagrams of complete multi-valve receivers.
- (2) Suggest alterations or modifications of receivers described in our contemporaries.
- (3) Suggest alterations or modifications to commercial receivers.
- (4) Answer queries over the telephone.

Please note also, that all sketches and drawings which are sent to us, should bear the name and address of the sender.

THE NEIGHBOUR AGAIN

"I see from your columns that you help listeners in their difficulties, so I would like you to help me in mine. It is not exactly a technical query so much as a legal one. I have lived in my flat for several years now, and the flat below has just been re-let to an individual with a five-valve set. The result is that he has put up an aerial from his window to the tree at the bottom of the garden, and it is just below mine the whole way down the garden. Result—he takes all the music, and I get nothing on my two-valve set. Can I compel him to move his aerial? I do not want to cause trouble, but it seems unfair that he comes in last, and with a more powerful set takes my enjoyment away. I should be glad of your advice, which I am sure will be helpful."—(A. K. T., Woolwich.)

You are certainly unlucky, but there is a solution, and it should not be necessary to resort to the Courts. You say he has put his aerial on to the tree and run it parallel with yours. That is the cause of the trouble—the two aeriels being parallel. The fact that he has five valves and you only two, does not enter into it. Your remedy, therefore, is to run the aeriels so that they are not parallel. As you both seem to prefer the tree to the expenditure of cash on a pole, it would appear that you must put up with the interference, but if you see your neighbour and explain the position he may be willing, as the last to arrive, to buy a pole. If not, explain to him that the time may come when you will go in for a more powerful set, and spend one evening searching for foreigners, with the result that his enjoyment may be spoilt by your tuning activities. He may see the other side of the question then, and buy a pole. At any rate, that is your only solution—to run the aeriels as nearly at right angles as possible.

VOLUME CONTROL REQUIRED

"A short time ago I built up a well-known make of kit set employing S.G. Detector and Pentode stages, but from the first instance of building up the set I have been troubled with distortion in a very bad form. I have written to the makers on various occasions, but they do not seem at all helpful over the matter except after a lot of correspondence they agreed to test the kit at a charge which I thought was very unreasonable after them claiming the set to be without distortion in their press adverts. The whole of the trouble appears to be on the pentode valve, for when using an ordinary low-power valve everything is O.K. (I have also tried a new Pentode). I pointed this out to the makers and their reply was to the effect that the Pentode would give a louder signal for a given input than the power and that I was probably trying to get too much from the valve. Does this mean that I ought to fit a Volume Control. I shall be grateful for any help you can give me."—(J. R. M., Margate).

We feel that as the makers state you are overloading your pentode valve, the inclusion of a volume control will assist considerably in enabling you to obtain good quality reproduction. We advise you to look at two articles which appeared in PRACTICAL WIRELESS, Number 1. One will be found on page 7

and is "Controlling Volume." This will show you where to fix a volume control and what value to use. The other article is on page 41 and is entitled "Do you understand your Loud-speaker," which points out to you the difficulties very often met with when using a pentode valve in the last stage and also explains several forms of tone control whereby the difficulties in matching speaker to pentode can be overcome.

AMERICAN NOMENCLATURE

"I have had an American Radio set and it puzzles me very much just how to set it up. There are six valves and the wiring reads in this fashion: (Red) A—, (White) 90—, (Black) A— C—, (Brown) 135 B—, (Yellow) 45—, (Green) C—. The reading here is different and I have asked a few who are like myself at a loss, hoping someone of your staff can solve the problem for me. Also what kind of accumulator would be best, as I think myself that a 2-volt would be of no use."—(G. D. Catrine, Scotland).

In America the following letters indicate the type of battery.

DATA SHEET No. 13

Cut this out each week and paste it in a notebook.

LITZENDRAHT WIRE

This wire consists of stranded high frequency cable, plaited together in sets of three. That is to say, 0/40 Litz. would be made up of three plaited lengths of gauge 40 wire (each length insulated), and two other similar sets of three, the complete three cables then plaited so forming one cable of nine separate wires. The first figure in the gauge gives the total number of separate wires, and is consequently always a multiple of three, and the second figure is the gauge of the individual wires.

Litz No.	Equivalent S.W.G.	Equivalent sectional area.
9/36	23	.024 in.
27/36	19	.040 "
81/36	16	.064 "
9/35	26	.018 "
27/35	21	.032 "
9/40	23	.0148 "
27/40	23	.024 "
9/42	30	.0124 "
27/42	25	.020 "
81/42	20	.036 "

- A.—L.T. accumulator.
- B.—H.T. Battery.
- C.—Grid bias battery.

You must find out the voltage of your valves to know the type of accumulator to use. As you do not give us the type numbers we cannot help you here. We feel sure you will find it quite easy to connect this set up now you know that batteries the leads should be taken.

SPEAKERS IN EVERY ROOM

"I wish to submit to your advice bureau the following query. I am contemplating using a loud-speaker in various rooms in my house, e.g., plugs being permanently wired up in each room and a loud-speaker being 'plugged in' when required. I am quite aware that I have to use an output filter, but is it advisable to simply connect up the plugs in series, so that they will be 'alive' so to speak when the set is switched on? I wondered if the above arrangement of having each one 'alive' all the time would be detrimental."—(M. E., Beamster).

You must not connect your loud-speaker plugs in series, because if you do you will have to have a shorting switch across each plug. They should be joined in parallel. This will not incur any loss when only one of the plugs is used at a time.

L.F. INSTABILITY

"I have recently built a three-valve receiver employing two L.F. stages, and the reproduction is very distorted. The output valve is a super-power valve with 150 volt on the anode and maximum grid bias, as recommended by the makers. There is, however, something wrong in the quality of reproduction. After reading your pages since No. 1, I have come to the conclusion, by careful testing, that the L.F. stages are to blame somewhere—but where, I cannot tell. I have a voltmeter and a milliammeter, so should be glad if you could tell me how to set about locating the nuisance."—(P. W. W., Hounslow.)

No doubt you have an unstable L.F. stage, and there are several ways of locating this. The simplest is to join the milliammeter in series with each anode in turn, and touch the grid terminals of the valveholders. If one of the valves is oscillating (as we expect) the anode current will show a sudden change. To cure it, you must include a high resistance in the grid lead, or otherwise decouple the grid, by inserting a resistance in the grid bias lead, with a condenser (2 mfd.) from the transformer to earth.

EXTERNAL INTERFERENCE

"I live on the front here, and we have a lot of fancy lighting along the front, and it seems remarkable that although my set, a 3 Screened-Grid Ferranti, is perfect all day long, immediately they set on the lights in the evening we can scarcely hear our signals for what sounds like atmospheric. Every day we are clear, and every night we get this terrific nuisance. Can you please tell me what to do for relief?"—(E. J. M., Eastbourne.)

It seems certain that the interference which you experience is due to the lighting cables along the front, coupled in some measure with "genuine" atmospheric, which are always worse after dark. If your aerial running parallel to the cables? If it is, you can cut out much of the interference by placing it at right angles to them. If it is a fairly big outdoor aerial, cutting down its length to some extent might also help; so might a small fixed condenser (about .0003) in series with your aerial (i.e., between the aerial and your set). Have you ever tried connecting your aerial terminal to earth, and the earth terminal to your aerial? Such an arrangement has been known to work in a case of interference from overhead cables for trolley buses, although it may have been in the nature of a freak in this particular instance.

A KICK-METER

"I should like your advice on the following point: I do not understand much about milliamps, millihenries, etc., but I do understand quality. On my set, which is a powerful one, I get a very loud output, but on the local station I get terrible distortion. I believe, from what I have read in your valuable book, that this is due to overloading of the last valve. I should like to install something to tell me when this (or whether this) is so. Please don't talk about amps and things, as I am afraid I do not understand them."—(R. D., Eastbourne.)

There is no need to understand any technical details to give you the assistance you need. Buy a milliammeter giving a reading of 20 milliamps. Don't worry what this means, simply buy one from the nearest wireless shop. The meter should then be joined between your output component and the anode of the last valve—that is, disconnect the wire in your set which is joined to the P terminal of the last valveholder and join that terminal to the negative terminal of the meter, and the wire which you have disconnected you should join to the positive terminal of the meter. Now when you switch on the set the needle of the meter will take up a certain position on the scale, and when listening you should adjust the volume so that the needle remains steady the whole time. Any kicking will indicate distortion due to overloading.

FREE ADVICE BUREAU COUPON

This coupon is available until Dec. 24th, 1932, and must be attached to all letters containing queries.

PRACTICAL WIRELESS, 17/12/32.

# CATALOGUES RECEIVED

To save readers trouble, we undertake to send on catalogues of any of our advertisers. Merely state in a postcard, the names of the firms from whom you require catalogues, and address it to "Catalogue," PRACTICAL WIRELESS, Geo. Neunes, Ltd., 8/11, Southampton St., Strand, London, W.C.2. Where advertisers make a charge, or require postage, this should be enclosed.

## "WEARITE" HETERODYNE FILTERS

RECEPTION of long distance and sometimes local stations is occasionally spoiled by heterodyne whistles, particularly when using a powerful receiver. One of the best remedies for this sort of interference is to use a filter for cutting out frequencies above a certain value. An efficient filter for this purpose is the "Wearite" filter, which is made in two patterns, type "A" to cut off at 3,500 cycles per sec., approximately, and type "B" to cut off at about 5,000 cycles. The filters are housed in neat moulded boxes, with terminals on top clearly marked. An additional use for the "Wearite" filter is the elimination of needle scratch and background hiss in radio-grams. The price for either type of filter is 10s. 6d., and further particulars are given in a leaflet we have just received from Wright and Weaire Ltd., 740, High Road, Tottenham, N.17.

## GOODMANS' LOUDSPEAKERS

A USEFUL range of permanent magnet moving coil speakers is given in an attractive folder issued by Messrs. Goodmans. Heading the range is the "Dreadnought" P.M. Moving Coil Speaker, housed in a polished walnut cabinet of modern design. A cobalt steel magnet of special design gives an intense flux density, and a specially treated "Veratone" cone is employed which ensures maximum sensitivity. The price of this speaker, including a universal output transformer, is 59s. 6d. The chassis alone, with transformer, is priced at 30s. 6d., complete with auxiliary baffle. The "Renown," another permanent magnet M.C. speaker, constructed on similar lines, is priced at 27s. 6d. as a chassis model, or 42s. 0d. housed in an attractive cabinet. Also included in the list is the "Sandringham" Cone Speaker, fitted with Goodmans' 4-pole balanced armature unit. This model, housed in a well finished, polished oak cabinet, sells at the very moderate price of 25s. 0d.

## Broadcast Query Corner

UNDER the above title, with the assistance of a recognized authority on foreign broadcasting matters and a regular contributor to wireless publications both at home and abroad, we are inaugurating a special Identification Service, which should prove of great assistance to our readers. When tuning in well-

known stations it happens frequently that listeners pick up wireless transmissions of which they fail to recognize the origin. It is to solve these little problems that the Broadcast Query Service has been organized.

In order that a careful search may be made it is essential that certain data should be supplied to the best of the inquirer's ability and knowledge. When sending such queries to the Editor the following rules should be followed:—

1. Write legibly, in ink. Give your full name and address.
2. State type of receiver used, and whether transmission was heard on headphones or on loud-speaker.
3. State approximate wavelength or frequency to which receiver was tuned, or, alternatively, state between which two stations (of which you have the condenser readings) the transmission was picked up.
4. Give date and time when broadcast was heard. Do not forget to add whether a.m. or p.m.
5. Give details of programme received, and, if you can, some indication regarding the language, if heard.
6. State whether and what call was given and/or kind of interval signal (metronome, musical box, bells, etc.) between items.
7. To facilitate publication of replies, append a *nom-de-plume* to your inquiry.

Although the service is mainly applicable to broadcasting stations, wherever possible replies will be given in regard to Morse transmitters (commercial stations, fog beacons, etc.) and short-wave broadcasts. For the identification, however, of stations operating on channels below 100 metres it will be evident to inquirers that a closer estimate of wavelength must be submitted than in the case of broadcasts on the medium or long waveband if successful identification is to be carried out.

All enquiries should be addressed to *The Editor, PRACTICAL WIRELESS, 8-11, Southampton Street, Strand, London, W.C.2,* and the envelope marked *Broadcast Query Service,* in top left-hand corner. Stamped addressed envelope should not be enclosed, as replies cannot be sent by post, but will be published in due course in each issue of PRACTICAL WIRELESS.

## Replies to Broadcast Queries

R. H. HUMPHRIES (Liverpool): If call sign is correct you appear to have picked up an experimental transmission by G8CX, Mr. H. W. Stacey, 42a, Hampstead Road, Fairfield, Liverpool. DAH-DE-DAH (Port Glasgow): MMM, May Island Lighthouse, MNG, North Ronaldshay Lighthouse, both on 1,000 m.; MMN, Regret, cannot trace. NEW LISTENER (Glasgow): No doubt, an American broadcast direct, but we cannot possibly identify wavelength, and consequently transmitter, from your condenser reading alone. O-v-2 (Ilford): Apparently amateur transmitter, but call sign is not in published list. Would advise you to write to Radio Society of Great Britain, 53, Victoria Street, S.W.1. CAM (W.C.1.): 200, 220 and 250 metres. L. G. KIRBY (Birmingham): SUC, Abu Zabal (Cairo) on 25.18 m., relayed to Sydney, N.S.W. MONTI (Southampton): Leningrad now on 857.1 m. (351 kc/s).

# DRY BATTERIES SUPERSEDED

INTERESTING FREE BOOKLET TELLS HOW TO SAVE MONEY WITH THE BATTERY THAT LASTS FOR YEARS . . . . .

It costs nothing to know how to get better results with

# STANDARD

## Leclanché Self-Charging PERMANENT H.T. BATTERY

We provide personal attention and show even bigger savings on your battery expense. Install the Standard which lasts for years, because it re-charges itself when the set is shut down. This PERMANENT saving is enjoyed by thousands of enthusiasts. Ample level current brings in difficult stations without background. Eventual replacements merely a matter of changing cartridges at a few pence each. Such great promise deserves your investigation. DO IT NOW.

STANDARD BOOKLET POST FREE  
Popular Type Battery for Ordinary Sets

Any voltage, Any capacity. Model H5. No. 3 size. 12,500 milliamp capacity. 126 volts, 84 cells. Price complete. **5/-** Down without trays. Tray containers extra if required.

Other capacities 2,000 to 25,000 milliamps.  
**STANDARD BATTERY CO., Dept. N.W.**  
184-188, Shaftesbury Avenue, London, W.C.2.

DESIGNS FOR APPARATUS FOR ANY RADIO PURPOSE, INCLUDING TRANSMISSION. OVERSEAS ENQUIRIES INVITED: ANY APPARATUS SUPPLIED. CONSTRUCTIONAL WORK UNDERTAKEN.

We undertake to solve your problems, including obtaining Amateur Transmitting Licence. Wastever your difficulty, write us.  
Charges: 3/- per query, four or more, 2/6 each, with diagrams.  
Radio Technical Agency (Dept. P.L.W.), 2, Westgate Chambers, Newport, Mon

# "NEW RADIOS FOR OLD"—FOR CHRISTMAS

**WE BUY YOUR OLD SET & SUPPLY YOU WITH A NEW SEASON'S MODEL**

Liberal Allowances and Balance Payable by Cash or Hire Purchase

HUNDREDS OF TESTIMONIALS FROM SATISFIED CLIENTS

**EVERY MAKE OF SET, KIT OR RADIOGRAM SUPPLIED**

Complete Transactions Executed by Mail.

It will pay you to write for particulars of our amazing exchange offer, enclosing 1½d. stamp, naming your old set and the new model you fancy. A FREE QUOTATION WILL FOLLOW.

**FREE** Wireless Set to introduce the Radialaddin Club.

Please forward this INQUIRY FORM (without obligation)

Please quote me free your allowance for the new set:

Make \_\_\_\_\_ Model and List Price \_\_\_\_\_

My present set is: Make \_\_\_\_\_ Batteries or Mains \_\_\_\_\_

Date of Purchase \_\_\_\_\_ Original Cost of Set \_\_\_\_\_

Balance of purchase price would be payable by me as follows:

Plan A. Whole of balance in cash.

Plan B. Whole of balance over six, nine, twelve months.

† Delete unwanted words.

NAME (in full) \_\_\_\_\_

(Block letters)

ADDRESS \_\_\_\_\_

Visit Our Showrooms

**RADIALADDIN, LTD.**  
THE LARGEST RADIO EXCHANGE IN THE UNITED KINGDOM,  
(Dept. P.R.W.) 46, Brewer Street, London, W.1. Phone Gerrard 4055.

## ADVERTISEMENT INDEX

Belling & Lee, Ltd.	.. 668
British General Mfg. Co. Ltd.	663
British Pix, Ltd.	
<i>Inside Front Cover</i>	
Cabaret Electric Co.	.. 670
Colvern, Ltd.	.. 663
Cossor, A. C., Ltd.	.. 645
Direct Radio ..	.. 655 and 670
Dubilier Condenser Co., Ltd.	667
Edison Swan Electric Co., Ltd.	.. 659
<i>Back Cover and</i>	

Electradix Radios ..	.. 670
Frost Radio, Co. ..	.. 664
<i>Inside Front Cover</i>	
Goodmans	
Hambling, A. W., Ltd.	.. 670
Heayberd, F. C. ..	.. 664
International Correspondence Schools, Ltd.	.. 666
Lissen Ltd. ..	.. 630
Mason, E. C. ..	.. 664

Newnes' Wireless Books	
<i>Inside Back Cover</i>	
Newnes' Presentation Binder	643
Peto-Scott Ltd.	
<i>Front Strip and</i>	
Pressland Clifford (Sales) Ltd.	663
Radialaddin, Ltd. ..	.. 672
Radio Resistor Co. ..	.. 668
Radio Technical Agency ..	.. 672
Reacto Appliances, Ltd. ..	.. 670

Ready Radio, Ltd. ..	.. 649
Slekton Products Ltd.	.. 670
Standard Battery, Co. ..	.. 672
Telegraph Condenser Co., Ltd.	.. 660
Telsen Electric Co. ..	.. 647
Wates Radio, Ltd. ..	.. 660
Whiteley Electrical Co., Ltd.	659
Wright & Weaire, Ltd. ..	.. 653
Woodware Supplies, Ltd.	
<i>Inside Front Cover</i>	

# MAKE YOUR FRIEND HAPPY THIS XMAS GIVE HIM A NEWNES WIRELESS BOOK

*The Wireless "Omnibus" Book*

## THE OUTLINE OF WIRELESS

by RALPH STRANGER

*Third Edition.*

THIS book has been prepared for the non-technical listener. Written in simple language it explains everything about wireless from A to Z as it has never been explained before. After reading "The Outline of Wireless," your set, which a few days ago was a sealed book to you, will now be yours to do with as you will. 840 pages. Fully Illustrated.

8/6, post free 9/-

*Some Press Opinions:*

"Mr. Stranger . . . gives a simple, yet authentic, introduction to all the 'mysteries,' and explains them away in an exceedingly interesting and readable way. . . . A book which should go on every listener's bookshelf."—*The Star*.

"A good book simply written."—*The Daily Mirror*.

" . . . It will be surprising if such an ably-written book as this does not find a wide sale."—*Daily News*.

" . . . Mr. Stranger has succeeded in doing one thing that will eudear him to all students interested in electricity. He has succeeded in making static electricity fascinating. . . . The book should prove of great value to all those who have a set or contemplate the construction of one."—*World-Radio*.

" . . . The subject, in both theoretical and practical aspects, is dealt with in a lucid manner guaranteed to inculcate knowledge without pains."—*Amateur Wireless*.

## RALPH STRANGER'S WIRELESS LIBRARY

for the

### MAN IN THE STREET

MATTER AND ENERGY

ELECTRONIC CURRENTS

ELECTRIFIED MATTER

MAGNETISM AND ELECTRO-MAGNETISM

SEEING BY WIRELESS (TELEVISION)

MODERN VALVES

WIRELESS COMMUNICATION AND BROADCASTING

WIRELESS WAVES

HOW TO UNDERSTAND WIRELESS DIAGRAMS

SELECTION OF WIRELESS SIGNALS

DETECTION OF WIRELESS SIGNALS

AMPLIFICATION OF WIRELESS SIGNALS

REPRODUCTION OF WIRELESS SIGNALS

WIRELESS RECEIVING CIRCUITS

WIRELESS MEASURING INSTRUMENTS

THE BY-PRODUCTS OF WIRELESS

1/- each, post free 1/2

## THE MATHEMATICS OF WIRELESS

by RALPH STRANGER

A book specially written to sweep away the greatest obstacle to the understanding of wireless—the mathematics of the subject. Original and lucid explanations of all branches of mathematics as applied to radio. Indispensable to all who would understand technical books and articles. Differential and Integral Calculus are explained at some length and the use of Logarithms and the Slide Rule clearly shown. 256 pages. Fully Illustrated.

5/-, post free 5/3

## WIRELESS THE MODERN MAGIC CARPET

by RALPH STRANGER

*Fourth Edition.*

If you know nothing about wireless this book will show you how to provide yourself with an interesting and absorbing hobby. If you are a listener, but rather weak on the technical side, it will save you much unnecessary worry and expense. If you wish to experiment, this volume will provide you with valuable experimental data. If you are an expert and have to lecture, it will give you some useful lecture material.

3/6, post free 3/9

## WIRELESS STEP BY STEP

by "DICTRON" (9th Edition)

A book which shows the wireless enthusiast how to obtain the maximum enjoyment from his wireless set. A practical book, expert in range, yet clear and concise in presentation. It explains in simple language the principles of radio communication. Its delightful simplicity and thoroughness will interest all, whether beginners or experts.

2/6, post free 2/9

## RADIO PLAYS

by L. du GARDE PEACH

Millions of wireless listeners who have been thrilled by such wireless plays as "The Path of Glory" and "The Marie Celeste" can now have these and other plays in book form. An indispensable guide for all who would write plays for the microphone. No library is complete without these thrilling plays.

2/6, post free 2/9

## FINDING FOREIGN STATIONS

by R. W. HALLOWS

This book will be welcomed by all wireless enthusiasts. The number of people who possess wireless sets of requisite power and who fail to get foreign stations satisfactorily, is legion. This book will enable you to obtain the best possible results of which your set is capable.

3/6, post free 3/9

Obtainable from all Newsagents, Booksellers and Bookstalls, or at post free rates from

GEORGE NEWNES LTD., 8-11, SOUTHAMPTON STREET, STRAND, LONDON, W.C.2

# "PRACTICAL WIRELESS" DATA SHEET No. 1

## Accumulator Charging

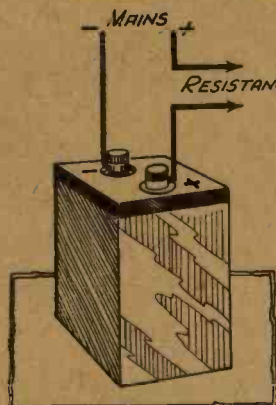

Charging from D.C. Mains.

The simple method of joining an accumulator to D.C. mains for charging purposes. The positive lead from the mains must be broken, and a suitable resistance inserted in this lead. A carbon or metal-filament lamp forms a very good resistance, and the table at the side shows the current passed by the different values of lamp. Of course, any form of resistance may be employed provided it regulates the current to a suitable value. An ammeter may be used to adjust this, and the charging rate should not exceed that which is given on the label of the accumulator.

**Notes on Carbon Filament Lamps.**—Carbon filament lamps are used for charging purposes chiefly because they take almost four times as much current per candle-power as do metal lamps. The table shows the current allowed by one lamp of the candle-power indicated on the various voltages shown. If the lamps available are only stamped in watts they consume, to find how many such lamps are required multiply the voltage of supply by the charging current required. This will give the total watts required.

Current in Amperes per Lamp.	Voltage of Supply.			At 4 watts per c.p.
	25	50	100-200	
1/4	—	—	8 c.p.	16 c.p.
1/2	—	8 c.p.	16 c.p.	32 c.p.
1	6 c.p.	16 c.p.	32 c.p.	60 c.p.
2	12 c.p.	32 c.p.	60 c.p.	100 c.p.

**EXAMPLE 1.**—Suppose the battery has to be charged at 10 amperes and the voltage of supply = 250.  
Total watts required =  $250 \times 10 = 2,500$ .  
Divide this value by the wattage of the lamps available to get the number required. Thus the number of 60-watt lamps required  
 $= \frac{2,500}{60} = 42$  approx.; 100-watt lamps = 25, etc.

**EXAMPLE 2.**—To find the current which a certain number and value of lamps will allow to flow.  
Four lamps of 60 watts each are available and the town supply is 250 volts.

$$\text{Current flowing} = \frac{\text{Number of lamps} \times \text{wattage of each.}}{\text{Voltage of supply.}}$$

$$= \frac{4 \times 60}{250} = \frac{240}{250} = .96 \text{ amperes.}$$

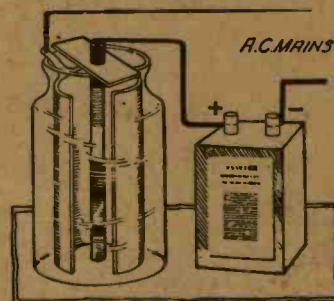

A Half-wave Chemical Rectifier.

With A.C. mains the current must first be rectified. This illustration shows a simple half-wave rectifier consisting of a jar containing two electrodes and an electrolyte. The electrodes are composed of lead and aluminium the former being in the form of a flat sheet bent to form practically a cylinder. The aluminium should be in the form of a rod. The jar is filled with ammonium phosphate, in the proportion of 2 1/2 lb. of salts to one gallon of water. To limit the charging rate lamps may be used as described for D.C. mains. Weak ammonia should be added from time to time to the solution to neutralise the electrolyte.

### CURRENT-CARRYING CAPACITY OF LAMPS.

CARBON-FILAMENT LAMPS.		
Candle-power.	Voltage.	Current passed.
8	110	.254
16	110	.509
32	110	1.018
8	220	.127
16	220	.253
32	220	.509

**Neutralising Spilled Acid.**—If electrolyte is spilled, it should be immediately treated with a neutralising solution such as sodium carbonate (soda) and water, or ammonia and water.

### CURRENT-CARRYING CAPACITY OF LAMPS.

METAL-FILAMENT LAMPS		
Candle-power.	Voltage.	Current passed.
8	110	.09
16	110	.18
32	110	.36
8	220	.049
16	220	.09
32	220	.18

### TABLE OF ACID AND WATER PROPORTIONS USING ACID OF 1.840 SPECIFIC GRAVITY.

Required Specific Gravity at 70° F.	Acid, 1.840 Specific Gravity.	
	Water, Parts by Volume.	Parts by Volume.
1.400	14	10
1.350	18	10
1.300	21	10
1.250	27	10
1.225	29	10

### ACID OF 1.400 SPECIFIC GRAVITY.

Required Specific Gravity at 70° F.	Acid, 1.400 Specific Gravity.	
	Water, Parts by Volume.	Parts by Volume.
1.300	4.5	10
1.280	5.5	10
1.275	6.25	10
1.265	6.4	10
1.255	6.65	10
1.250	6.75	10

### ACID TEMPERATURE CORRECTION TABLE.

Condition of Cells.	Actual Hydrometer readings at temperatures shown below to give 1.280 at 60° F.						
	40° F.	50° F.	60° F.	70° F.	80° F.	90° F.	100° F.
Fully charged	1.288	1.284	1.280	1.276	1.272	1.268	1.264
Half discharged	1.207	1.204	1.200	1.196	1.193	1.189	1.186
Fully discharged	1.115	1.113	1.110	1.107	1.104	1.101	1.098

Another method of rectifying A.C. current is to employ a metal rectifier. This form of rectification is used principally for trickle charging. A small transformer is joined to the mains giving a step down suitable for the rectifier. The output may then be adjusted by suitable resistances to suit the accumulator, either 2, 4, or 6 volt.

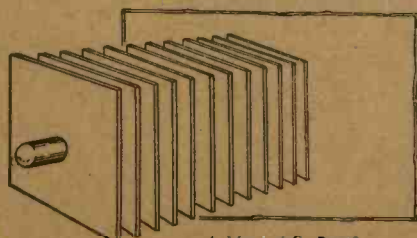

A Metal A.C. Rectifier.

**The Charging Rate.**—The maximum safe charging rate of an accumulator is approximately one-tenth of its actual capacity. For instance, the charging rate of a 60 ampere-hour cell would be 6 amps. Any excess would cause heating and disintegration of the plates.

Use glass, china, earthenware, or lead-lined vessels.

Pour the acid carefully into the water—not the water into the acid, as this may cause spluttering and possible personal injury.

A more efficient method of using the chemical rectifier shown above. Four of the jars are joined as shown, and this results in full-wave rectification. The jars are joined in pairs in series, and then connected back to back. The accumulator is joined between the two pairs.

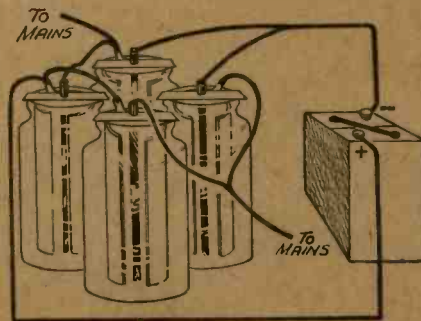

A Full-wave Chemical Rectifier.





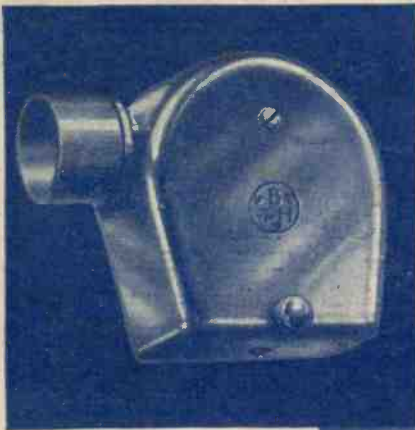

**B.T.H. MINOR PICK-UP** has been re-designed and improved and now includes a special volume control fitted in the base of the tone-arm pillar. This model is constructed in a one-piece moulding of B.T.H. "Fabrilit" and is recommended to those requiring a highly efficient but inexpensive pick-up. Price 25/-.

**B.T.H. SENIOR PICK-UP** (1933 model). This has been completely re-designed and gives an even better response curve than hitherto. Free coupling of the head to the tone-arm reduces pressure on records and facilitates needle changing, and a ball-bearing universal joint on the tone-arm support ensures easy tracking. And independent and specially designed volume control of correct value is supplied with this connoisseurs' model. Price £2.2.0 complete with volume control.

**B.T.H. SENIOR PICK-UP** complete with four adaptors to fit standard tone-arms. Price 27/6

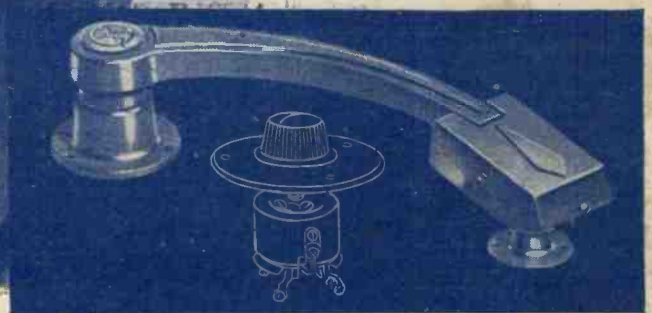

**THIS  
PICK-UP  
MINDS  
ITS OWN  
BUSINESS**



## **PICK-UP and Tone Arm**

**EDISWAN RADIO**  
100% BRITISH

It's a pick-up that doesn't take liberties with the record—it plays all there is on the record—no less, no more. That is why leading radiogram manufacturers use it; why radio engineers choose and recommend it—for its even, accurate and sensitive response over a wide range of frequencies.

**All good radio dealers stock B.T.H. pick-ups and will be pleased to demonstrate them.**

THE EDISON SWAN ELECTRIC CO. LTD.



155 CHARING CROSS RD., LONDON, W.C.2  
W194

**P.W. Gift Stamp No. 12**

Printed by NEWNES & PEARSON PRINTING CO., LTD., Exmoor Street, Ladbroke Grove, W.10, and published by GEORGE NEWNES, LTD., 6-11, Southampton Street, Strand, W.C.2. Sole Agents for Australia and New Zealand: GORDON & GOTCH, LTD., South Africa: CENTRAL NEWS AGENCY, LTD. *Practical Wireless* can be sent to any part of the world, post free, for 17/4 per annum; six months, 8/8. Registered at the General Post Office for Transmission by Canadian Magazine Post.

FREE INSIDE! "COILS AND COIL WINDING" DATA SHEET

# Practical Wireless

3<sup>D</sup>

Published every Wednesday by  
**GEORGE NEWNES LTD.**  
DECEMBER 24th, 1932  
Vol. 1 — No. 14  
*Registered at the G.P.O. as a Newspaper.*

COLLECT OUR

## DATA SHEETS

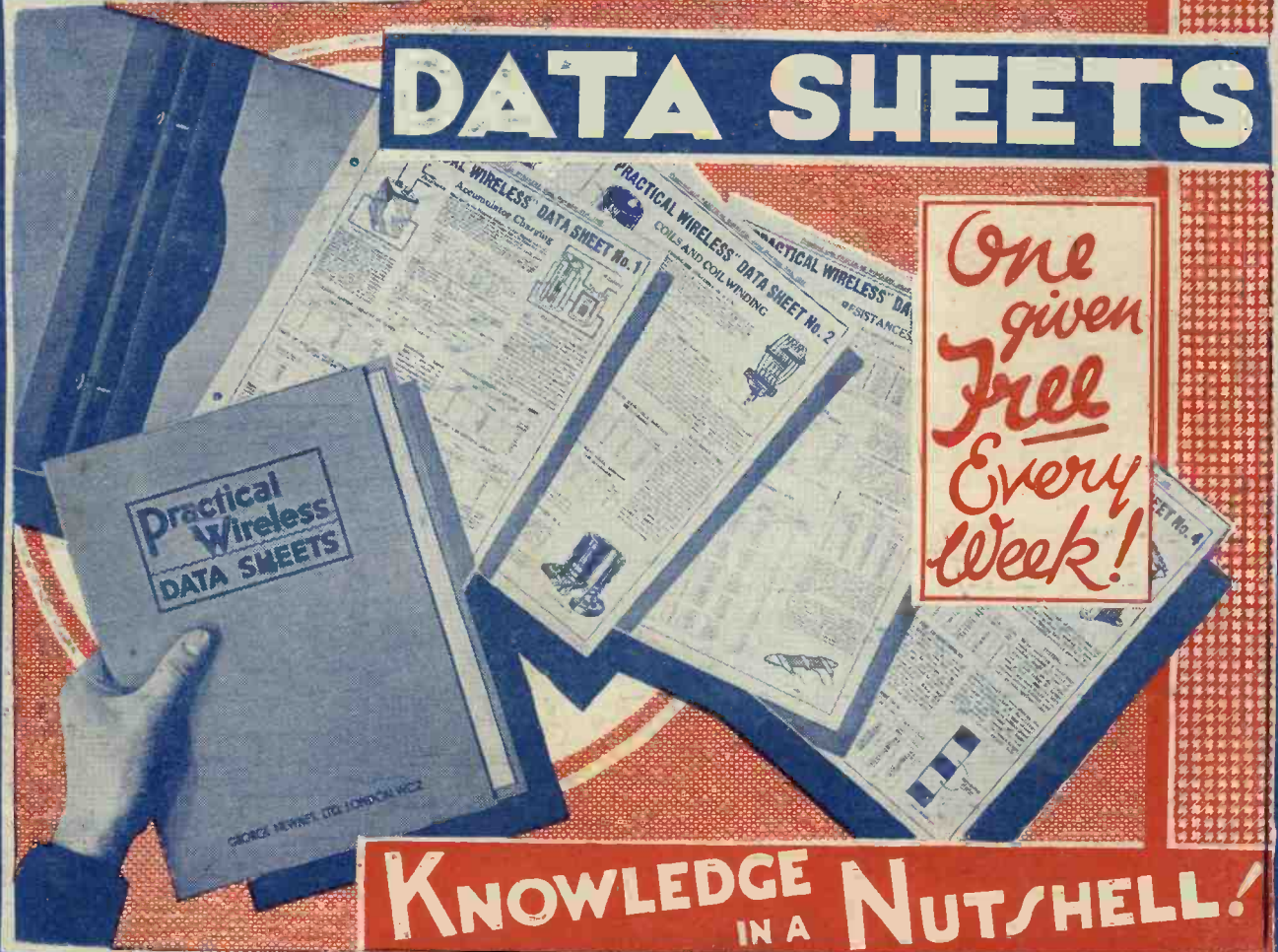

*One given Free Every Week!*

### KNOWLEDGE IN A NUTSHELL!

— how to bring in more stations  
*fit* **COSSOR S.G. VALVES**

# FREE!

## 6 BRILLIANT CIRCUITS for the HOME CONSTRUCTOR

Designed by experts, these circuits are for amateur constructors requiring a really modern selective set which can easily be made at home.

The Lewcos Components recommended for use in the circuits assure an unparalleled degree of success in both reception and reproduction.

If not obtainable from your dealer, write to-day for your FREE copy to Radio Publicity, Section W.

# Lewcos

REGD

### MANUFACTURERS OF MODERN RADIO COMPONENTS



**LEWCOS RADIO PRODUCTS FOR BETTER RECEPTION**  
THE LONDON ELECTRIC WIRE COMPANY AND SMITHS LIMITED, CHURCH ROAD, LEYTON, LONDON, E.10



# QUALITY Produces EFFICIENCY

**TESTED BEFORE DESPATCH**

The original BECOL ebonite low loss formers are thoroughly reliable. They are used in all parts of the world. Look for the BECOL trade mark. Ask your dealer. If unable to supply, write direct. Send now, enclosing 6d. (post free) for up-to-date handbook of tuning coils for DUAL RANGE, BANDPASS, and SUPER-HET. circuits. Fully illustrated with data. A very interesting handbook.

**RODS. SHEET. TUBES. PANELS**  
**The BRITISH EBONITE Co., Ltd.,**  
Hanwell, London, W.7

THE *famous*

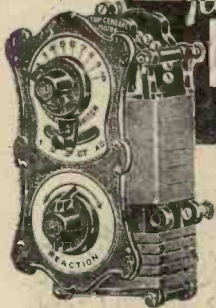

## BRITISH GENERAL TUNING UNIT

**NOW REDUCED TO 10/6**  
Increased demand, enlarged turn-over enables us to offer this popular tuning unit at this remarkable price. Cuts out coils. Covers all wave-lengths from 200 to 2,000 metres. Easy fixing; simple tuning. Free wiring diagrams supplied.

From all dealers or direct:  
**BRITISH GENERAL MANUFACTURING CO. LTD.,**  
Brockley Works, London, S.E.4.

## Autokoil



"AUTOKOIL"  
All-wave Tuner

Embodies variable re-  
action coil and five-way  
selector switch. Covers  
200 to 2,000 metres.  
Engraved Escutcheon  
1/- extra.

Price  
**12/6**

**THE NEW ALL-WAVE TUNER**  
that simplifies set building and  
increases selectivity and volume.  
**READ THESE "TEST" REPORTS:**

"AMATEUR WIRELESS" said:  
"Six miles from Brookmans Park it was  
possible to separate the two stations"  
"The wave range covered was  
from below 200 to above 2,000."  
"POPULAR WIRELESS" said:  
"Gives fine results both in point of  
Power and Selectivity."

Simplifies Set Construction. Only  
5 connections to make in as few minutes.  
Descriptive Leaflet "PR" and FREE Circuit  
on request.

BLUE PRINTS for "AUTOKOIL THREE" or  
"AUTOKOIL REINARTZ THREE." 1/- each.  
Kits for above, and for ALL "Practical Wireless"  
sets. Details and Prices on request.

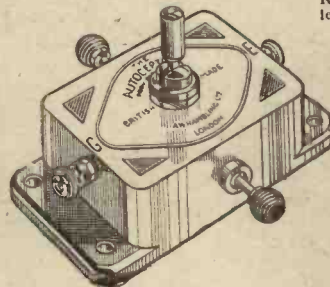

"AUTOCEPTOR"  
Programme Selector

British Made. Well  
constructed. Enclosed  
in dust-proof Green  
bakelite case.

Price  
**6/-**  
Post Paid.

## THE "AUTOCEPTOR"

This wonderful programme Selector  
gives you at the touch of one Switch,  
either of any two pre-arranged  
stations and yet does not interfere  
with normal tuning for any other  
stations at any time.

"Autoceptors" can be used in any set  
but method of wiring to circuit varies;  
full and simple instructions with each one.  
Only 2 connections to make. Write for  
Leaflet "A.P."

HEADPHONES for "Practical Wireless"  
"EMPIRE SHORT-WAVE THREE." Sensitive,  
Light-weight, 4,000 ohms. With cords. Only a  
few left. PRICE 4/6 Post Paid.

**A. W. HAMBLING, LTD.,** 16, Alfred Place, TOTTENHAM  
COURT ROAD, LONDON, W.1  
Telephone: MUSEUM 7651.

# A TRIUMPH OF PRECISION

● Gives extremely fine tuning. Similar in construction to the J. B. "NUGANG" Condensers, but the trimmer of front section is operated independently from the receiver panel by means of a second knob concentric with the main tuning knob. Rigid one piece chassis, very robust construction. Trimmer to each stage. Heavy gauge wide spaced aluminium vanes. Special bearings to rotor ensure permanent accuracy. Capacity .0005.

Matched to within  $\frac{1}{2}$  mmfd. plus  $\frac{1}{2}$  per cent.  
Complete with disc drive and bakelite escutcheon plate,  
2 gang - 8/6      3 gang - 27/-

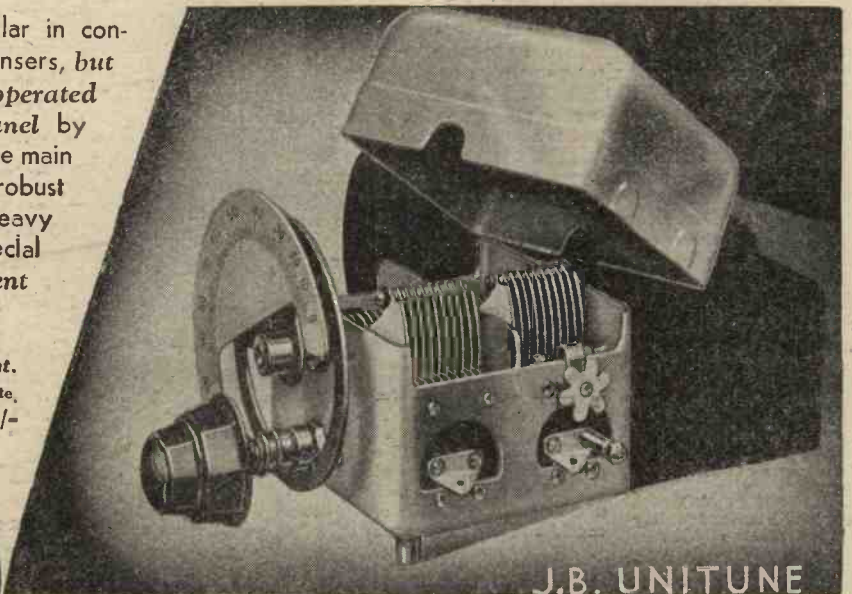

J.B. UNITUNE

## PRECISION INSTRUMENTS

Write for Complete Catalogue.

Advertisement of Jackson Bros. (London) Ltd., 72, St. Thomas' Street, London, S.E.1  
Telephone: Hop 1837.

# Build with your own hands — this better set — save pounds — success a certainty!

**GET YOUR  
FREE COPY  
OF MOST SUCCESSFUL  
CHART  
EVER PUBLISHED  
enabling you to build  
MOST SUCCESSFUL  
SET EVER  
BUILT!**

**YOU ARE TOLD EXACTLY WHAT  
TO DO WITH EVERY  
SINGLE NUT  
AND SCREW**



**THE ONLY  
KIT YOU CAN  
BUILD YOURSELF  
EMPLOYING  
METALLISED  
S.G. HIGH-MU  
DETECTOR &  
ECONOMY POWER  
PENTODE VALVES**



**COMPLETE IN CABINET £6.5s OR 11/6 DOWN AND  
WITH LOUDSPEAKER TWELVE MONTHLY  
PAYMENTS OF 10%**

Lissen have published a 1/- Constructional Chart, giving the most detailed instructions ever printed for the building of a wireless set.

You can't go wrong—you are told what to do with every part, every wire, every terminal—everything is identified by photographs. Everybody, without any technical knowledge or skill, can safely and with COMPLETE CERTAINTY undertake to build this most modern of radio receivers from the instructions given and the parts Lissen have supplied.

This new Lissen SKYSCRAPER Kit set is the only one on the market that you can build yourself employing a Metallised Screened-grid Valve, High-Mu Detector and Economy Power Pentode. Around these three valves Lissen have designed a home constructor's kit the equal of which there has never been before. Why be satisfied with whispering foreign stations, when you CAN BUILD WITH YOUR OWN HANDS this LISSEN SKYSCRAPER that will bring in loudly and clearly distant stations in a profusion that will add largely to your enjoyment of radio?

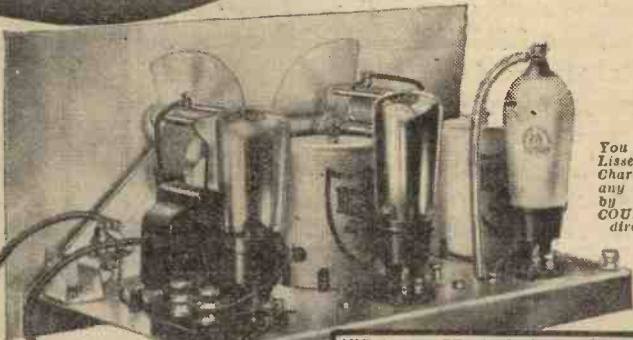

You can get the Lissen Skyscraper Chart FREE from any radio dealer, or by posting this COUPON direct to factory.

**NOW YOURS FOR ONLY 8/6 DOWN**

To-day you can buy the LISSEN SKYSCRAPER KIT on Gradual Payment Terms. Skyscraper Chassis Kit, complete with Valves, CASH PRICE 89/6. Or 8/6 down and twelve monthly payments of 7/6. Skyscraper Kit complete with Walnut Cabinet and inbuilt Loudspeaker, as illustrated, £6 5s. CASH; or 11/6 down and 12 monthly payments of 10/6.

**KIT COMPLETE INCLUDING  
METALLISED S.G.  
HIGH MU DETECTOR  
& ECONOMY POWER  
PENTODE VALVES.** **89/6**

# LISSEN SKYSCRAPER 3 KIT

**COUPON**  
Insert this COUPON in unsealed envelope with only halfpenny stamp and address to:—  
**LISSEN LIMITED, Dept. PR. 15, Worples Road, Isleworth, Middlesex.** Please send me FREE copy of your 1/- Skyscraper Chart.

Name: .....  
Address: .....

Are You Collecting Our DATA SHEETS? See pages 692 & 693



**Practical Wireless**

EDITOR:  
Vol. 1. No. 14, F. J. CAMM Dec. 24th, 1932.

Technical Staff:  
H. J. Barton Chapple, Wh. Sch., B.Sc. (Hons.), A.M.I.E.E.  
Frank Preston, F.R.A., W. J. Delaney, W. B. Richardson.

## ROUND *the* WORLD of WIRELESS

### Listen to New York at Lunch Time

WITH even a modest short-wave receiver it is now possible to hear at 1.0 p.m. daily W3XAL, Bound Brook, N.J., on 16.878 m. (17,780 kc/s), as this station comes on the air at 8.0 a.m. Eastern Standard Time. With a cheery "Good morning, ladies and gentlemen," the announcer takes you over to the New York studios for light music or short sketches. At the end of each broadcast, the call of the National Broadcasting Company of America is given, preceded by three notes (on oscillating valves) generally adopted as an interval signal.

### International Christmas Peace Programme

THE UNION INTERNATIONALE DE RADIODIFFUSION at Geneva is endeavouring to arrange a special international broadcast during the Christmas Holidays. Steps are to be taken to induce all European stations to transmit this Christmas Peace programme.

### Austria Broadcasts on Short Waves

UOR2, the Vienna experimental transmitter on 49.4 metres (6,072 kilocycles) may now be heard working every Tuesday and Thursday from 1.30-6.0 p.m. and again from 7.0-9.0 p.m. G.M.T. when it relays the Vienna programmes.

### The B.B.C. Nigger Minstrels

BROADCASTING HOUSE proposes to revive the Nigger Minstrel entertainment by organising a troupe of its own, the Kentucky Minstrels, and the first transmission will be heard by Regional listeners on January 6th. Such a combination will form a good background for the introduction of popular negro spiritual songs and short sketches. The company will include the traditional Bones, Cornermen, Stump Orators, etc.

### A Batch of Plays

AMONGST a number of works to be broadcast during December and January the B.B.C. has selected *The Forest* (John Galsworthy); *The Green Goddess* (William Archer); Flecker's *Hassan* and Sheridan's *The School for Scandal*. A new microphone version of Charlotte Brontë's best-known work, *Jane Eyre*, will be given on January 2nd.

### IMPORTANT!

Readers please note that the Gift Stamp (No. 13) the last for their Presentation

## WIRELESS CONSTRUCTOR'S ENCYCLOPAEDIA

appears on the back cover of this week's

### "PRACTICAL WIRELESS"

Will readers who are qualifying for this Presentation Encyclopaedia affix the last Gift Stamp to their Subscription Voucher, and forward the completed Voucher in accordance with the instructions thereon TODAY?

### PLEASE DON'T DELAY.

As announced last week there will be an enormous number of volumes to despatch, and it will necessarily take some little time to get them all out. All applications will be treated in strict rotation. If you do not receive your volume within 21 days of the despatch of your application—notify by post card giving date application was made.

*It will be impossible to despatch any volumes until after the Christmas Holidays*

NOTE: Carefully read instructions on your Subscription Voucher and make sure it is properly filled in, in every detail, before forwarding.

### YOUR LAST GIFT STAMP APPEARS THIS WEEK

Don't forget to complete and send in your Subscription Voucher immediately.

"Practical Wireless"

Presentation Department,  
39, King Street, Covent Garden,  
London, W.C.2.

### Have You Heard Porto Rico?

IN addition to a number of American transmissions heard after midnight, listeners now report good reception of WKAQ, San Juan, Porto Rico, on 236.1 m. (1,270 kilocycles) between 2.0 and 3.0 a.m. G.M.T. All announcements are made in English and Spanish.

### New Hungarian Relay Station

ACCORDING to a report the Nyirehaza 6-kilowatt relay station has started its tests on 261 metres; in common with Magyarovar (210 m.) it re-broadcasts the Budapest programmes.

### To Facilitate the Identification of Stations

COMPLAINTS have been received by the U.I.R. at Geneva, that European transmitters do not give out their calls sufficiently often, and a request has been made to the studios to broadcast the name of the station at the beginning and at the end of all transmissions, and whenever opportunity occurs in the course of the programme. The method adopted by the U.S.A. stations of calling at regular intervals is a good one.

### The Result of the Madrid Conference

ALTHOUGH the International Conference at Madrid is almost at an end, it is expected that the broadcasting world will reap but little advantage from the decisions taken by the delegates. At the utmost some six or seven channels may be added to the band allocated to telephony transmitters. No alterations are likely to take place before the next meeting of the International Union of Broadcasters at Prague in 1933.

### Held Over

OWING to great pressure on space, we have been compelled to hold over the continuation of Mr. Barton Chapple's second article on "Thinking in Terms of Frequency."

NEXT WEEK'S DATA SHEET  
*will be entitled*  
**"RESISTANCES"**

# ROUND *the* WORLD of WIRELESS (Continued)

## The Christmas Radio Pantomime

THE most suitable period of the evening, 8 o'clock, has been chosen for the broadcast of Ernest Longstaffe's pantomime, *Jack and the Beanstalk*, on December 26th (National) and December 27th (Regional). The cast includes Leonard Henry who, we are told, will not impersonate the beanstalk!

## A Play Without Words

**WORKING DAY** is the title of one of the shortest plays on record; it will run for less than fifteen minutes, and will consist of sound effects only. The novel programme has been specially written for the microphone by Dallas Bower, the well-known film personality. Without words he will endeavour to give an impression of the passing hours.

## Call of the North Italian Stations

WHEN a simultaneous broadcast is carried out by Milan, Turin, Trieste, and Genoa, you will not necessarily hear any of these names mentioned. The interval signal used will be that of Turin, the trill of the nightingale, and the call put out by the woman announcer: *Eh Yah* (E.I.A.R.) *Radio All'Italia* (Upper Italy).

## The Father of 5,000 Children

PAPA STEFANE is the pet-name given to the director of the Katowice (Poland) station, Dr. Tyminiecki, who some four years ago founded the International Radio Club, calling itself the Katowicards. Every Wednesday and Friday, from 10.0 p.m. G.M.T., Papa Stefane replies to letters received from his unseen children, some five thousand members of this vast association. The languages used in these broadcasts are French, English, Italian, German, and any other which may be found necessary.

## These Tri-lingual Difficulties

SIMILARLY to Switzerland, Belgium in its population has subjects using three different languages—namely, French, Flemish and, since the Great War, German. For this reason the two Velthem Louvain transmitters which broadcast the Brussels programmes respectively transmit in French and Flemish. To cover the country efficiently, however, and to satisfy all classes of the community, it is now proposed to erect a smaller station in the east of Belgium to broadcast German entertainments.

## More Than the Usual Excerpt

FOR the first time in the history of British broadcasting listeners are to hear, on December 24th, the relay of an entire Gilbert and Sullivan opera, namely *The Yeomen of the Guard*, as performed at the Savoy Theatre. It will be transmitted by the National stations.

## INTERESTING and TOPICAL PARAGRAPHS

### A Genuine Russian Cabaret

**LA CHAUVE SOURIS** (The Bat Theatre of Moscow), consisting of

### TELEPHONE TALKS TO AEROPLANE



Two-way communication, both by telephone and telegraph wireless, during tests at the BALDONNELL AERODROME, was established with perfect results.

twelve artists, is back in London from a world tour. Arrangements have been concluded to broadcast a performance through the Regional wavelength on December 24th. The entertainment in-

## SOLVE THIS!

### Problem No. 14

Johnson's wireless set was installed in the dining-room, as this faced the garden and permitted of easy connection to the aerial. However, for the Christmas holidays he decided that the set would be more convenient in the drawing-room in the front of the house, and accordingly carried out the following arrangement. The set was taken into the new room and a length of ordinary twin flex was run round the picture rail from one room to the other. The aerial and earth leads were joined to the ends of the flex in the dining-room and the opposite ends were joined to the receiver. Johnson could not get any signals from this arrangement. Why? Three books will be awarded for the first three correct solutions opened. Mark envelopes Problem No. 14, and send to the Editor, PRACTICAL WIRELESS, Geo. Newnes, Ltd., 8-11, Southampton Street, Strand, London, W.C.2, to reach us not later than December 26.

### SOLUTION TO PROBLEM No. 13

A short-wave converter will only work with a receiver employing H.F. stages, as it converts the existing receiver into a super-heterodyne set. Jenkins' receiver did not employ H.F. stages, and he should therefore have obtained an adaptor instead of a converter.

The following three readers received books in connection with Problem No. 13:—

Mr. F. Speight, 1000, Manchester Road, Bradford, Yorks; Mr. G. W. Darby, 12, Wood Lane, Hemel Hempstead, Herts; Mr. M. A. Price, 37, Malmesbury Road, Morden, Surrey.

cludes Russian and Tzigane folk songs as well as a number of original sketches.

### Clearing Up a Puzzle

WIRELESS listeners have been somewhat mystified by the result of a prosecution in which a fine was imposed by a magistrate on a man who was using two radio receivers at the same address. As stated by the daily Press the facts of the case were not made perfectly clear to the public, as the wireless sets in the house were owned by two different people, and one licence only had been taken out. The listening licence issued by the Postmaster-General covers the installation of a receiving station, i.e., the operation of a wireless receiver. Such a licence permits the use, if desired, of a separate set for the domestic staff, and the holder of the licence may also possess a portable set. The use of the receivers is also granted to members of the licensee's family. In the case, of course, of an apartment house or of a house sub-let into flats, a separate licence is required by each tenant.

### The Danish Interval Signal BETWEEN items in the Copenhagen programme.

you may hear a special musical signal which consists of a phrase taken from a Danish folk song dating back to the early fourteenth century. It is reproduced by an instrument resembling an electrical musical box, and has been adopted as the Copenhagen signature tune.

### German Night Listeners

GERMANY is the country for statistics, and during the past year considerable investigation has been carried out by the authorities in matters relating to the broadcasting stations. According to a recent census, ninety per cent. of German listeners use their wireless receivers between 7.30 and 11.30 p.m., and fifty per cent. are still searching the ether for programmes at 2.0 a.m.; one hour later some twenty per cent. are still up. The early morning broadcasts of physical exercises at 5.15 and 5.45 a.m., and the concert which follows them are enjoyed by sixty-five per cent. of the total number of licence-holders!

### Tired of Politics

FOR some few weeks as a special feature the Madrid (EAJ7) studio relayed, for the benefit of its listeners, debates at the Cortes or Spanish Parliament; later, speeches from the sittings of the Municipal Council were also transmitted. Following a series of noisy meetings, in which the speeches of Cabinet Ministers were shouted down, the Government has withdrawn from the studio the permission to broadcast the Cortes at work—much to the satisfaction of listeners who are asking for less exciting and more peaceful musical entertainments.—JACE.



# Simple Points Concerning Detection and Amplification

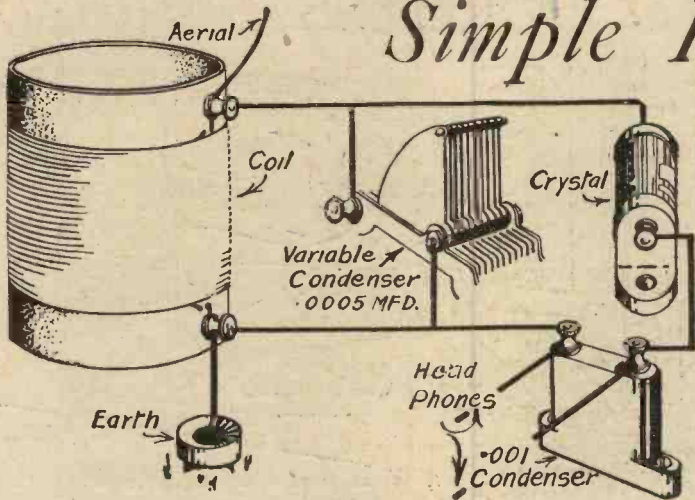

Fig. 1.—Simple crystal set in pictorial form.

An Interesting Article on Simple Points Concerning Crystal Detectors Compared with Valve Detectors. Amplification Before and After Detection, etc.

By GILBERT E. TWINING

**W**IRELESS waves which are transmitted from a broadcasting station radiate in all directions at the speed of light, that is to say 186,000 miles per second. They are made up of the carrier wave, high-frequency currents of some 1,000,000 cycles per second, and microphone currents, low-frequency of speech and music; these lower frequencies are modulated or mixed into the carrier wave at the transmitting station.

**Detection**

The detector's work in a set is to separate the low-frequencies of sound from the high-frequencies of the carrier wave. Now a wireless wave keeps changing its direction, becoming alternately positive and negative. The effect of every surge of current in one direction is instantly obliterated by the following surge in the opposite direction; therefore, before the current can be utilised it must be rectified, which means that one half of the oscillating current, together with the high-frequency current of the carrier wave, must be eliminated, and this is rendered possible by either a valve or a crystal detector.

**The Crystal Set**

The crystal, in the case of crystal receivers, does the work of getting rid of the unwanted half of the modulated carrier wave and leaves a series of high-frequency pulsations varying in amplitude. The crystal does not eliminate the high-frequency currents, however, as does the valve detector, but passes them on to the headphones, which have a very high resistance caused by the great number of turns of fine wire with which the electromagnet coils are wound, for this is done to obtain as much inductance as possible. As the high inductance of the 'phones offers a considerable impedance, the high-frequency rectified current is caused to be by-passed, that is to say, an easier course is offered through either a small fixed condenser of .001 capacity or the leads of the headphones are utilised, if they have sufficient capacity, to by-pass the high-frequency current to earth. In Fig. 2 is shown a diagram for a simple crystal set, and in Fig. 1 the same circuit in pictorial form. The great disadvantage of the crystal is that it cannot amplify. It will not hand out more power than it receives from the aerial; it is for this

reason that the valve is so popular, for not only is it far more sensitive to the incoming signals than a crystal detector, but its magnifying powers are simply enormous, deriving its extra power or energy, as is well known, from batteries.

**The Valve as Detector**

The detector valve, as mentioned before, has the ability to demodulate the incoming wireless waves, which means that it separates the high frequency carrier waves from the low-frequency waves,

the plate circuit into the grid circuit again, and this has the effect of greatly increasing sensitivity. The nearer the reaction coil is brought to the aerial inductance, or alternatively, the more turns of wire there are on the coil the more energy will be fed back and therefore stronger will be the results. There is, however, a limit to the amount that can be fed back, for if too many turns are made the set will be in continual oscillation and not working at its best, besides interfering with other receiving sets in the neighbourhood. If more amplification is needed, then the only way is to add another valve.

**Amplification**

The wireless waves picked up by an aerial are not strong enough after deduction alone to actuate a loud-speaker, therefore, amplification has to be undertaken. Two methods of amplifying are resorted to at the present time; these are high-frequency before detection and low-frequency which comes after detection.

**Amplification Before Detection**

It has been explained at the commencement that the signals which are tuned in by the aerial system are high-frequency oscillations, being the carrier wave with its waves of speech and music modulated into it. Now this can be amplified—made stronger—by the H.F. side of the set before detection, that is to say a valve can be incorporated to amplify the signals, but not change them in any way whatsoever before the detector has demodulated them. This will mean another tuned circuit for improving the selectivity of the set and, as most people are aware, in a modern three-valve set this is the section taken up

(Continued at foot of page 678.)

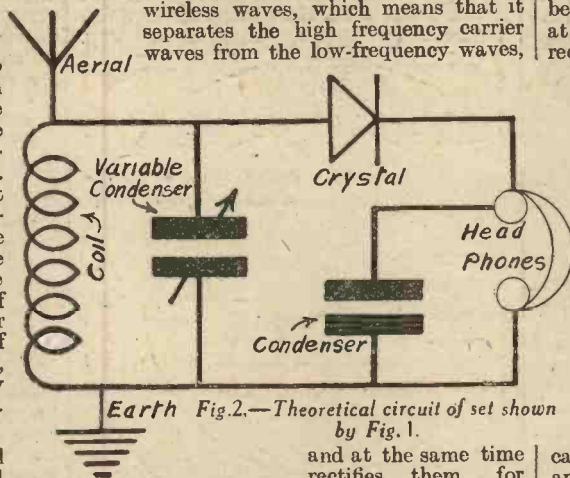

Fig. 2.—Theoretical circuit of set shown by Fig. 1.

and at the same time rectifies them, for the valve only allows current to flow through it in one direction. The valve will give much stronger signals than the crystal detector on account of the batteries employed, but by altering the circuit slightly it is possible to get a still further increase in signal strength.

**Reaction**

Reaction is the means whereby the incoming signals may be strengthened, and stations received which would otherwise be unheard. The reaction takes the form of a coil coupled to the aerial winding, enabling it to feed back some of the energy of

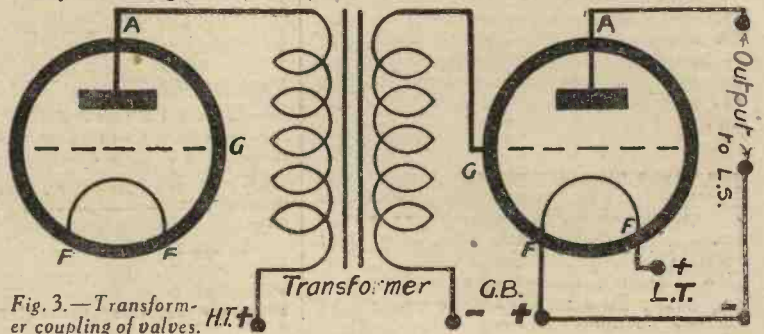

Fig. 3.—Transformer coupling of valves.

# Simple Experimental Makeshifts—2

Described by  
FRANK PRESTON,  
F.R.A.

Temporary Measures to Try Out Before Fitting  
New Components ; and Other Useful Hints.

## Station Calibration

A good number of commercial sets on the market have their tuning dials marked off to show the names of stations instead of degrees of revolution. The station-calibrated set is very convenient for family use, and an ordinary receiver can be converted quite easily by gluing a paper scale on top of the ordinary condenser dial. If the condensers are of the type with a revolving dial, an annular piece of paper should be cut to the shape shown in Fig. 1 (a) and glued to the edge of the dial. With a condenser having a celluloid disc dial, a circular piece of paper can be glued over the figured scale. In either case the set is calibrated by tuning in the various stations and marking them on the new scale as shown in Fig. 1 (a). If the names are put on in small letters there might be sufficient space to add a few details in regard to the times of transmissions, etc., of some of the foreign stations.

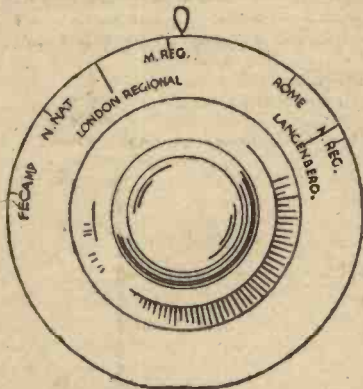

Fig. 1 (a) and (b).—Making a scale in order to log the names of the stations which can be received.

## Home-made Wander Plugs

It sometimes happens that a few extra wander plugs are required when trying out a new set, or it might even be found that standard plugs do not make proper contact

with the sockets of a particular high-tension battery. In either case quite good and useful plugs can be made from split pins of the kind used for locking nuts, etc. If the bared end of the flex is bound tightly round the loop and the contact covered with insulation tape, quite a good job will result.

through the necessary components to a power-valve which is the low-frequency amplification side of the set actuating the loud-speaker.

## SIMPLE POINTS CONCERNING DETECTION AND AMPLIFICATION

(Continued from page 677.)

by the screened-grid valve. To explain it as simply as possible, the reason for amplification before detection is accounted for by the fact that the voltages picked up by the aerial, and fed to the detector, are too weak to actuate the valve efficiently.

## L.F. Amplification After Detection

When the Detector Valve has dispersed the carrier waves, all that should be left are the necessary waves of sound which originate from the broadcasting studio of the station to which the set is tuned. These are passed on as complete signals

The output from the detector valve is not connected directly to the input of the L.F. valve, for the simple reason that the anode current of the detector circuit through the valve would be applied to the grid of the amplifying valve, which obviously would be wrong. It is necessary to connect between the two circuits a L.F. transformer, see Fig. 3. This will only allow the low-frequency signals to flow from the detector through the primary windings to the secondary windings of

In any case, try going to higher voltages up to about 100. If you cannot feel anything at a 100 volts, try wetting the fingers a little more or go through the same process with the little fingers. If you get too much of a "kick" at full voltages, try the test with the fingers dry. You will soon be able to recognise the presence of a voltage, and this will be found very useful in ascertaining whether the H.T. supply is reaching the speaker, valve holders, etc. The method is to hold one finger on the H.T. negative terminal, and with the other touch the anode terminal of the valve holder or the loud-speaker terminal. Any normal person can apply these tests with perfect safety so long as the high tension voltage does not exceed 100 or so—most people can go to much higher voltages if the fingers are kept dry.

## Screened Wire

In a set where most of the components are screened it is often advantageous to screen some of the wires; in particular, that from the anode terminal of the S.G. valve and the one connecting the anode of the detector valve to the reaction condenser. Screened wire can be obtained, but only in comparatively long lengths, so as only a small amount is required it might not be considered worth while to buy a quantity. Ordinary insulated connecting wire, or even flex, can be screened very efficiently by winding a length of copper wire, about 26's gauge, round it in the manner shown in Fig. 2. Of course, the wire used for screening must be connected to earth or H.T.—; this can generally be done most conveniently by joining it to a nearby screen.

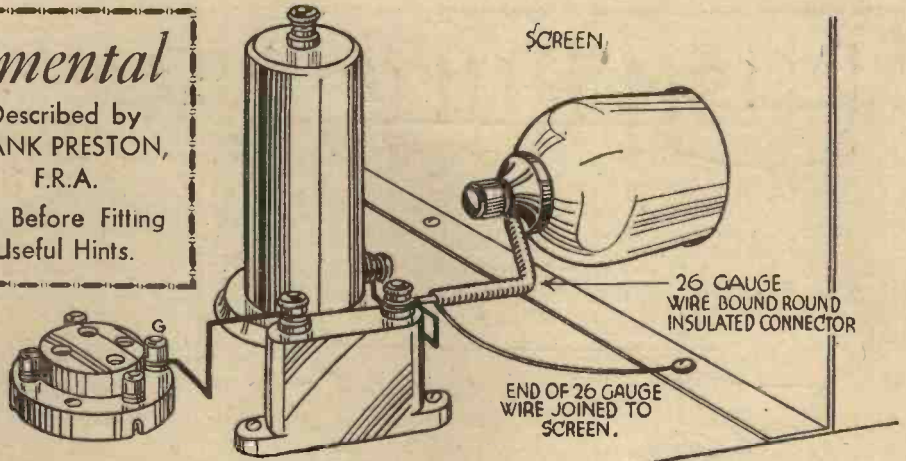

Fig. 2.—Screening the lead joined to the anode of a screen grid valve.

the transformer. The transformer not only separates the anode current from the preceding valve, dividing the circuits, but it also amplifies the low-frequency signals which are applied to its primary windings. When the secondary windings on a transformer have more turns of wire than the primary, an increase in the signal voltage at the output or secondary windings is obtained. It will be understood that by altering the number of turns on the secondary in relation to the primary, the voltage, or rather the ratio of the transformer, is altered. The makers quote these ratios on the cases in terms of 3 to 1 or 5 to 1, etc., as the case may be.

# PUSH-PULL AMPLIFICATION

What this Form of Amplification does, and some of its Advantages—Explained by  
E. G. ROWE, B.Sc. (Eng.), A.C.G.I.

**P**USH-PULL is generally considered as a luxury, and as only practicable when a very large output is required, but this idea is wrong because it is often requires double the input signal voltage to operate it.

similar the anode currents will be equal but opposite in phase, and must be recombined by means of an output transformer.

The output of two valves in parallel might, at first sight, appear to be the same as that of two valves in push-pull, but this is not so, because the limiting factor with ordinary valves, second harmonic distortion, is practically cancelled out in push-pull stages. One can expect on this account something like a 20 per cent. gain in undistorted output, but this is by no means the most important advantage in push-pull. Because of the cancelled second harmonics a better quality can be expected. Again,

you will notice that the alternating currents in the two valves are opposite in phase. Therefore they balance out in the H.T. supply leads, and thus, with little or no A.C. ripple there is little feedback and decoupling may be much reduced on this account.

Hum is similarly lessened because any fluctuations in the A.C. supply affect both valves equally and as the supply to each valve is opposite in phase to the other they balance out. This makes push-pull particularly useful to those having A.C.

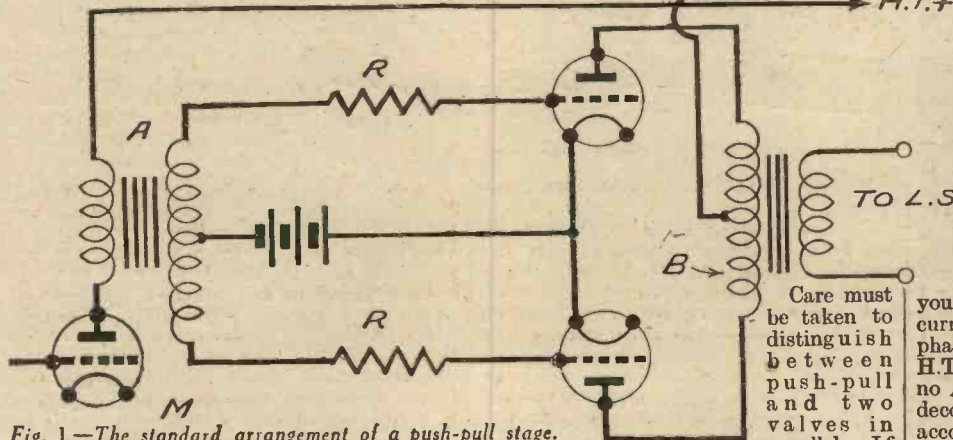

Fig. 1.—The standard arrangement of a push-pull stage.

very true economy to use it. The input required to obtain lifelike reproduction from the modern loud-speaker is large and, to get this from the last stage of their equipment, experimenters used to employ high anode voltages in order to handle the large grid swings on the input side of this stage. This necessitated special and larger valves of the LS5 type.

Now push-pull amplification will handle the same grid swing using ordinary voltages and ordinary super-power valves. This is one of its advantages—it is possible to operate the loud-speaker on half the H.T. volts required when not using this system, or, to put it more technically, the push-pull amplifier doubles the permissible grid swing in the output stage, for a given H.T. voltage.

### When To Use Push-pull

Push-pull is only capable of giving greater volume when one output valve of similar size is overloaded; that is, there must be sufficient amplification in the stages before the push-pull stage to cause a grid swing too great for one output valve to handle without distortion. This is so because push-pull by its arrangement

two valves are in parallel their filament connections are in common, and the grids and plates respectively of the two valves are joined together. Thus the A.C. resistance is halved and the plate current consumption is doubled, but the amplification

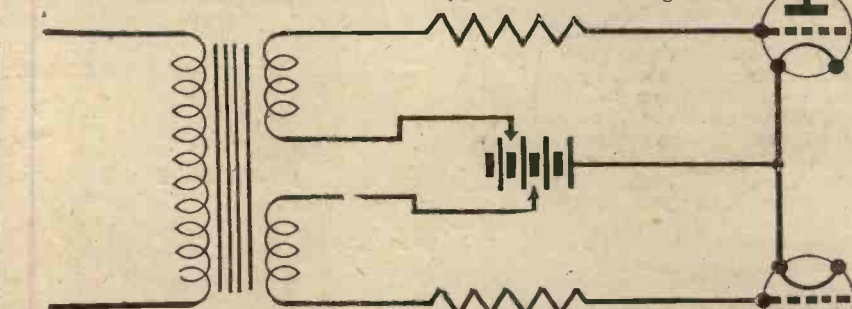

Fig. 2.—How to keep the two valves balanced by applying separate grid bias.

and grid swing remain unaltered. Thus the parallel connection only means the sharing of the grid swing between two valves.

### Principle of Push-pull and Its Differences

Fig. 1 shows the usual push-pull arrangement.

A is an intervalve transformer with a centre-tapped secondary; B is an output transformer with a centre-tapped primary. One half of the total voltage from the valve M goes to the grid of each push-pull valve, but they are 180° out of phase; that is, when a signal causes the grid of one valve to swing positive the grid of the other swings negative by an equal amount. Thus, if the valves are

mains receivers, and trouble from ensuing hum. The one drawback to this system is a tendency to parasitic oscillations, which can be overcome, if necessary, by putting resistances of the value of 10,000 to 100,000 ohms in the grid leads to the valves, as shown in Fig. 1. Matched valves are generally used in push-pull, and these can be kept matched indefinitely by supplying them independently with grid bias. Fig. 2 illustrates this method.

In the place of the tapped transformers it is possible to use two transformers in series. A tapped choke may also be used and may be connected as in Fig. 3. Thus, in conclusion, we may summarise the advantages of push-pull as—the better handling of power output with improved quality, the reduction of harmonic distortion, reduced hum and feedback with consequent simplified decoupling arrangements, and, finally, we may describe it as an excellent means of handling a big grid swing with a modest anode voltage.

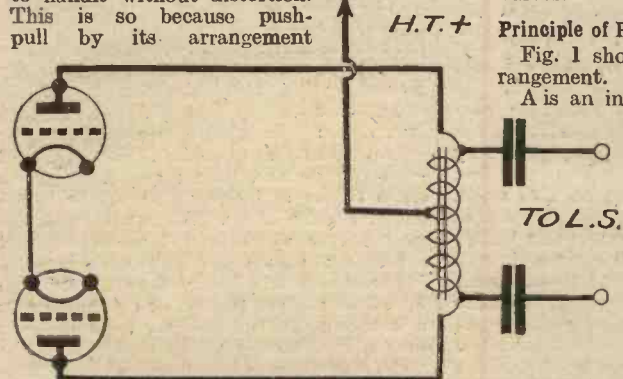

Fig. 3.—Employing a centre-tapped output choke in place of the normal output transformer.

# Simplifying Soldering

Some Hints on the Correct Method of Soldering, and Instructions for Making a Useful Soldering Stand.

By H. BEAT HEAVYCHURCH.

**W**ONDER why it is that such a very large percentage of wireless amateurs and home constructors fight shy of that very simple job of soldering. How often we see a set boomed, and one of its advantages set out in bold type—"No Soldering Required." Frankly, I find it difficult to understand the attitude of a man who will point proudly to work he has undertaken with infinite care and patience and yet refuses to try his hand at the simple task of soldering. When properly carried out, the joints in a set, in my opinion, are far better when soldered than when attempting to hold two or more pieces of wire under a terminal screw. All commercial sets are soldered, and this is carried out, in the main by *girls*, so come along, you menfolk, take a little lesson in the art, commit to memory the one or two rules that ensure a satisfactory job, and never look on the task with horror again.

The remarks which follow are general in character and apply to other soldering work besides wiring up the set. Soft soldering, or sweating, as it is sometimes termed, is probably one of the commonest known methods of uniting separate metal parts. It has no equal for simplicity and is entirely satisfactory for small work. The solder used usually is an alloy of tin, lead and bismuth, all of which have a low melting point and will run freely when brought in contact with the heated copper bit or soldering iron. It is very economical when considered from the heat point of view.

Hard soldering or brazing is a method very similar in actual practice except that the medium used is usually spelter, silver solder or brass wire. These require a greater heat to run them and, therefore, a good blow-lamp or gas blow-pipe, with foot bellows, would have to be used. It would also be necessary to build a brazing pan. This is usually a shallow iron pan in which coke or broken brick is heaped or banked up, so that the work to be operated on will not lose the heat.

## Fluxes Used

In both methods a flux has to be employed. The purpose of this is twofold—to prevent oxidation, and to keep the work clean. For hard soldering, the only flux required is borax. This may be used dry, but a more convenient form is to mix with water to form a milky fluid. This will penetrate into joins or seams, providing a clean surface to the metal, and ensuring a free flow of the spelter or whatever other medium is employed.

An excellent flux for soft soldering may be prepared by mixing the following:—

Spirits of salts (killed)	..	1 part
Vaseline	..	½ part
Resin	..	2 parts

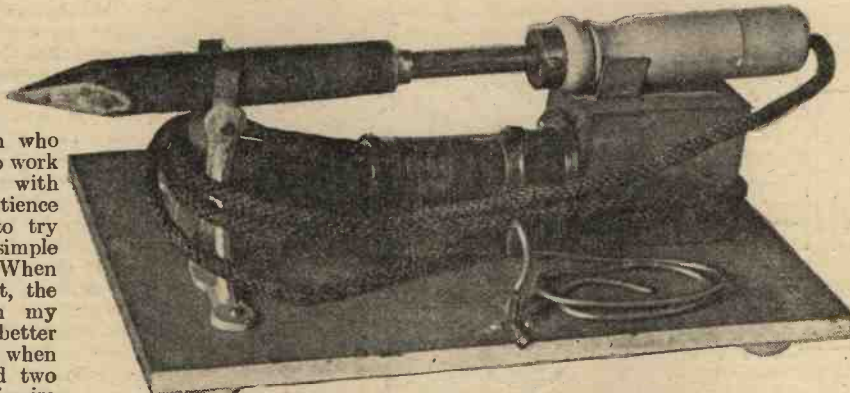

Fig. 1.—The complete soldering stand described in this article.

Killed spirits of salts may be prepared by first obtaining an earthenware bowl or jar into which a quantity of spirits should be poured. Next add clean cuttings of sheet zinc. This will immediately cause the spirit to "live" or effervesce. The operation should be done in the open air, as the fumes given off are objectionable.

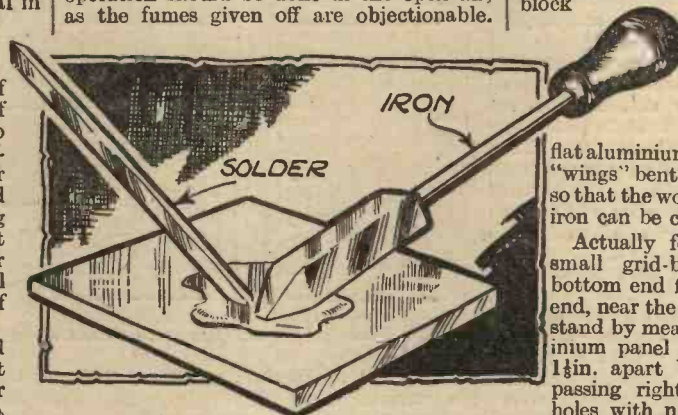

Fig. 2.—The correct method of tinning a soldering iron.

Continue to add zinc cuttings until the effervescence ceases; the spirit is now killed and should be strained off and bottled. The flux paste mixed in the proportions given will be found suitable for general purposes, but if a flux is required specially for wiring purposes, use only resin and vaseline. This is non-corrosive, an essential feature in that class of work. It will be necessary to melt the resin in order to mix with the vaseline, so first of all crush to a powder, then place in a tin and melt slowly, taking care not to overheat. It should then be poured into the vaseline and stirred. An iron suitable for small soldering work may be purchased for a few pence, and it will probably need tinning, that is, coating with solder, a very simple process.

## Heating the Iron

Heat the iron until it assumes a dull red shade, *not red hot*, then quickly file over each of the tapering faces towards the tip. Follow this operation by working the iron over a piece of brass or copper which has previously been prepared with a liberal smearing of flux, at the same time bringing the stick of solder in contact with the iron (See Fig. 2). Care should be taken not to overheat the iron, as this tends to amalgamate the lead and copper, producing a very hard skin which must be filed away. Re-tinning is then necessary before using again.

## Electric Soldering Iron

Personally I discarded the gas iron or ordinary copper bit a long time ago for one of the more modern electric soldering irons. These have very many advantages, amongst which can be mentioned the maintenance of a steady heat without the rapid cooling associated with the ordinary iron, cleanliness, saving of time when several soldered joints have to be made and the extra convenience. The accompanying illustration (Fig. 1) shows the simple stand I made up for everyday use, and in case other readers may care to follow a similar plan, let me briefly describe it. The iron shown is a standard one marketed by most good electrical stores, and it has proved a very good servant.

First of all cut out a wooden base about 12in. by 7in. by ¾in. and fix on the centre line about 1in. from one end a wooden block 3in. by 2in. by 2½in. high as shown. This can be held in place by a pair of wood screws passing through the baseboard from the underside into the block. Screw to the top of this a piece of

flat aluminium about ½in. wide having two "wings" bent at right angles near one end so that the wooden handle of the soldering iron can be clipped into this and not fall.

Actually for this purpose I used a small grid-bias battery clip with the bottom end flattened out. At the other end, near the hot copper bit, make a little stand by means of a pair of stout aluminium panel brackets. These are held 1½in. apart by a 6 B.A. brass screw passing right through the top screw holes with nuts on either side of each bracket to hold the screw rigid. Incidentally include two strips of brass—1in. by ¾in. by 1-32in.—held by the nuts against the bracket sides—as these will allow the bit to remain on the screw without any fear of it rolling off and burning the table.

Last of all, if your electric soldering iron lead does not terminate in a dual adaptor—two pin and lamp holder fitting combined—fit one on and then purchase a batten lamp holder and screw this to the inside of the wooden block. When not in use the lead can be wound round the block and brackets, as shown, and the adaptor inserted in the batten lamp holder to ensure that the lead does not get twisted or damaged. As a further addition I hold my stick of solder on the baseboard by a small clip. This is very convenient when "running" a little bead of solder on to the heated iron before

(Continued at foot of page 688.)

# Make Your Own Smoothing Chokes

In this Article all the Data Necessary for Construction of Three Different Chokes is given

By FRANK PRESTON, F.R.A.

SINCE the recent publication of two articles dealing with the construction of mains transformers I have been extremely pleased to find that a large number of readers are interested in the making of their own mains equipment. This is indeed a welcome sign, showing as it does that the readers of PRACTICAL WIRELESS are really practical people who wish to make the very best of their hobby by getting out of the common rut so amply filled by those whose idea of wireless does not go beyond the mere mechanical assembly of component parts. After all there is no better way of learning than by doing, and I sincerely hope that all readers will cultivate that pioneering spirit which has made radio what it is to-day. But I am digressing from my point; what I ought to say is that, in view of the popularity of the two articles referred to, I feel that I can offer some details required for the construction of smoothing chokes without any apology being necessary.

### Simple Construction

The construction of a smoothing choke is even simpler than that of a transformer, for, although it follows the same general lines, the choke only requires a single winding.

### Inductance and Current

Before making a smoothing choke we must decide just what kind of an instrument is required. The first consideration is the inductance needed, and in nearly every case a choke of about 30 henries will give all the smoothing that is necessary. Next in order of importance is the current that the choke must carry; this depends entirely on the output of the rectifier and high-tension current consumption of the set. The larger this current, the larger must the choke be to cope with it, because, as you are probably aware, if a heavy current is passed through a small choke the inductance of the latter is reduced and there is a danger of its core becoming saturated. In addition, heavier gauge windings are required to carry a larger amount of current.

### D.C. Resistance

Lastly we must take into account the permissible voltage drop across the choke windings. For example, if the output from the rectifier (or the voltage from the D.C. supply) is only 230 volts and the voltage required by the set is 200, only 30 volts can be spared. If the choke had a high D.C. resistance it would "drop" considerably more than 30 volts, and in consequence the voltage actually applied to the set would be less than it should be.

### Practical Data

The calculations employed in finding the volume of iron core, number of turns, and gauge of

below the maximum, but, even though an ample factor of safety has been allowed, the current should never be allowed to exceed the figure stated.

From what has been said it will be clear that the choice of chokes 1, 2 or 3 will now depend not only upon the current-carrying capacity but also upon the permissible resistance. For example, suppose a choke were required for an eliminator working from 220 volts D.C. mains and that the set consumed 30 milliamps at 200 volts. So far as current is concerned, choke 1 would be satisfactory, but by applying Ohm's Law (voltage drop equals current multiplied by resistance) we find that this choke will drop  $30/1,000 \times 1,100$ , or just over 30 volts, and so the voltage applied to the set would be only 190. In most cases the 10 volts deficiency would be of no account, but if it was it would be necessary to choose choke 2, which would cause a smaller voltage drop due to its lower D.C. resistance.

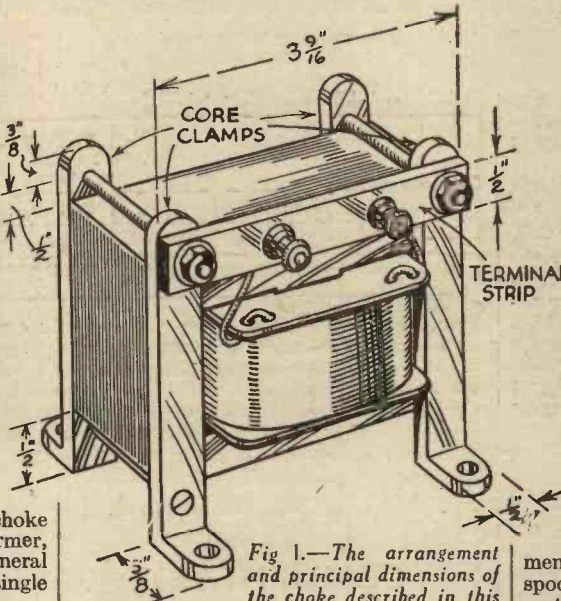

Fig. 1.—The arrangement and principal dimensions of the choke described in this article.

wire required to produce a choke of given inductance when carrying a specified current are somewhat involved, and thus instead of presenting the numerous formulæ I have prepared the table given on next page in the hope that this will be much more useful.

The table gives all the necessary data for the construction of three different smoothing chokes, each of which is suitable for a particular value of high-tension current. It should be explained that each choke has an inductance of approximately 30 henries when carrying the maximum current specified. The inductance in every case would be correspondingly higher if the current were reduced below the maximum figure, and any choke can be used with complete satisfaction on currents

### Making the Choke

Having decided on the choke required, the construction can be commenced. First we must make a winding spool like that shown in Fig. 2. No matter which of the three chokes is to be made the fibre end cheeks will be the same size, because each core has a cross section of 15-16in. by 1 1/8in. The length of the spool, however, will vary with the core size, so the appropriate lengths are given in the table. The method of making the spool was described on page 229 of PRACTICAL WIRELESS No. 5, so there is no need to repeat that information here. In this case only two fibre end cheeks are required, and they should be of the size shown in Fig. 2. See that the cheeks are a good fit on the square tube, and that the whole spool is quite rigid.

### The Winding

Next obtain the necessary wire, of which the gauge and weight are given in the table. Solder a 12in. length of flex to the end of the wire, and cover the joint with a small strip of insulation tape. Anchor the end of the flex by passing it through the two holes in the end cheek, leaving about 2ins. projecting from the spool for making subsequent terminal connections. Take the flex round the spool, and then continue to wind on the thinner wire. There is no need to count the turns, because the exact number is not critical, and if you use the weight of wire stated no difficulty can occur. Keep the turns as even as possible, and after putting on half the total number cover with empire tape or oiled silk. Let this come well up against the end cheeks, so that there will be no danger of subsequent turns slipping past it. When the total number of

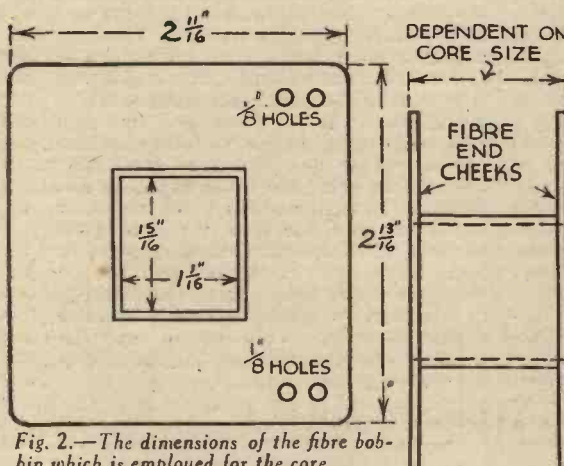

Fig. 2.—The dimensions of the fibre bobbin which is employed for the core.

turns have been wound solder another 12in. length of flex to the end of the winding. Take this once round the spool and anchor it by passing it through the other pair of holes in the end cheek. Finally, cover the whole winding with empire tape and apply a coat of varnish shellac.

### The Core

The next part of the work is to assemble the core stampings. They are inserted into the spool from alternate sides, putting in a "T" and a "U" from one side and then a "T" and "U" from the opposite side. So that each stamping is insulated from its neighbours the insulated (white) sides of all stampings should face in the same direction. The specified number of stampings will just fit into the spool, and to make them quite tight the last few might have to be lightly tapped into position.

### Core Clamps

The core must now be fitted with four mild steel clamps like those shown in the sketch of Fig. 1. These are made from lengths of  $\frac{1}{2}$ in. by  $\frac{1}{2}$ in. metal, and are attached by means of four 3-16in. by  $\frac{1}{2}$ in. bolts. The actual lengths of the clamps will depend upon the choke being made, but those dimensions given in Fig. 1 will enable you to determine the lengths applicable to your own case.

A terminal strip of ebonite is fitted

underneath the heads of the two top clamping bolts, as shown, and the two flexible leads are finally soldered to the terminals.

### The Cost

As some readers will wish to have an idea of the price of the materials used the following figures are given:—

	s.	d.
6 doz. No. 30A Stalloy stampings ..	2	11
6 doz. No. 30 Stalloy stampings ..	3	0
6 doz. No. 4A Stalloy stampings ..	3	6
8ozs. 38 s.w.g. Enamelled Wire ..	1	10
12ozs. 36 s.w.g. Enamelled Wire ..	2	6
1lb. 2ozs. 34 s.w.g. Enamelled Wire ..	3	3

The cost of the iron clamps, bolts, terminal

	Size of Core Stampings	Length of Spool	No. of turns.	Gauge of Enamelled Wire.	Weight of Wire.	Approx. Inductance.	Max. Current.	Approx. D.C. Resistance.
1	30A	13-16in.	8,000	38 s.w.g.	8ozs.	30 henries	30 m.a.	1,100 ohms
2	30	1 1/2in.	8,000	36 s.w.g.	12ozs.	30 henries	50 m.a.	720 ohms
3	4A	1 1/2in.	8,000	34 s.w.g.	1lb. 2ozs.	30 henries	100 m.a.	500 ohms

strip, terminals and sundries will depend upon facilities available for their purchase, but in any case one and sixpence will easily cover them. From this it will be seen that the prices of the chokes will vary from about six shillings for the smallest to about eight shillings for the largest.

### Using Ready-made Parts

If there are any readers who do not possess the few tools required for making the chokes described, or who cannot spare very much time, they will be pleased to know that suitable winding spools, core clamps and terminal strips can be obtained ready-made. These are supplied by the Lumen Electricity Company, 9, Scarisbrick Avenue, Litherland, Liverpool, who also specialise in Stalloy stampings and instrument wires. The spools are made in bakelite, and one Size No. 4 spool just fits the size 30A stampings. Two size No. 30 spools will be required for size 30 stampings and two size No. 4 spools for the size 4A stampings. When two spools are used, half the required amount of wire should be put in each and the two windings

connected in series, taking care that the turns in each case go in the same direction. As the spools will only take five dozen pairs of stampings, the numbers of turns (and hence weights of wire) given in the table should be increased by about 20 per cent. to maintain the same inductance.

### Christmas is Here !

HERE we are with Christmas on the top of us and, no doubt, like myself, you are wondering what good things Christmas will bring forth. If you are seriously interested in radio, don't feel yourself too old for the stocking trick, try a pillow-case: the former will not hold a new set or component of reasonable size, though I have known many big enough for a loud-speaker. It is time for you to put on your thinking-cap and make out that list of "what I want." Have a good look round the radio stores, and I am sure you will find something which will improve your installation and give delight, not only to yourself, but to the rest of the household if it is chosen with a view of improving reception. The other contains many good things at all hours of the day, and if you are not taking advantage of them—well, you are not getting full value out of that licence fee.

### Speakerless Speech Mystery

What is quite a common experience is to hear music and speech emanating from a wireless set even when the loud-speaker is not connected to the output terminals. It is a phenomenon which has troubled many of those who have observed it in their receivers. The worry is to know whether it is a defect in the receiver, and if so, how can it be corrected. It may be taken for granted the general cause of the noise, for it is a noise, even though the music or speech is distinguishable, can be found almost immediately. There is sure to be something loose in the receiver, which vibrates when the receiver is in operation in just the same way as the diaphragm moves in some types of loud-speakers. There are two forces which may cause the trouble, namely, magnetic and electric. Magnetic forces are the most common. Very often the loose part is the iron covering of a low-frequency transformer, or even the power transformer when A.C.

## A RADIO COMMENTARY

By "Grid Leak"

mains are used for the power drive, being situated within the leakage field of a low-frequency transformer. The magnetic lines of force act on the transformer case and set up a vibration. Sometimes it may be traced to a part of the lamina, or core of the transformer. It will always be noticed that the vibrations are louder when the loose member is iron or other magnetic material. It must not be thought, however, that loose iron members are alone subject to vibration. Any loose metal when subjected to strong electric alternating or varying forces, vibrates, and it is found more severe the higher the varying voltage may be. So, as a loose piece of iron may be subject to the influence of both magnetic and electric forces, the loose member vibrates in the same way as the diaphragm of a speaker. The hum which is often heard from an eliminator is due to the same trouble, but in this case it is usually the power transformer which is the cause. It has often been traced to a loose casing, which vibrates because of the leakage flux from the transformer itself. This being the cause of speech and music heard from a set to which a speaker is not attached, the remedy will be quite obvious. The loose and vibrating member must be traced. Sometimes this can be accomplished by tightening up the clamping of the core, or spreading over it a little rubber solution. The easiest way to trace the offender is by pressing the vibrating part with the finger.

### Inaudible Frequencies

Some time ago, a correspondent told me of a converter which he had invented, and per-

mitted of his speaking into a microphone to send commands to a dog several miles away. These sound waves were converted by means of the instrument into high-frequency currents, inaudible to the human ear, but heard and acted upon by the dog. It is well known that many animals can hear sounds which are inaudible to the human ear, just as others can see that which is invisible to most. That letter whetted the appetite of my brain in its search for knowledge. I took a long journey to a good address in Cornwall, and you can imagine my surprise on arrival finding the correspondent was an inmate of a mental home.

### The Leak Leaks

Another case was a lady, much perturbed during the period of spring cleaning. She was dusting the radio receiver and noticed the accumulator, used for filament heating, was only half full of acid. A few days previously she had read one of my articles on the importance of keeping the acid level  $\frac{1}{2}$ in. above the plates. She appealed for advice, asking what might be wrong with the set, seeing she had examined the wiring and interior of the set very carefully, and had been unable to find any trace of water or dampness inside the cabinet. She feared the grid leak was not leaking correctly. Evidently, like most women not being technically minded, she was under the impression the acid flowed through the wiring of the set to and from the battery, with the grid leak as a kind of safety valve. Yes! I understand your smiles, but do you realize if she had not asked the question, and received the subsequent explanation, she would still have been in ignorance. That is where I come to my point: if you are in doubt do not be afraid of asking, and do not be disturbed if your question raises a supercilious smile from the one whose knowledge on radio matters you had considered worthy of inquiry, but may be little better than your own.

**THE HALF-GUINEA PAGE**

# Radio Wrinkles FROM READERS

**A Handy Spring Socket Connector**  
 IN the hunt for selectivity, it is quite usual to connect a "pre-set" or other small variable condenser temporarily in circuit with the aerial. Often, however,

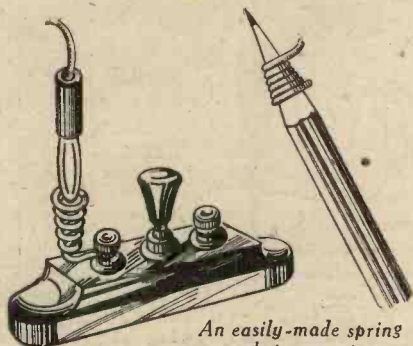

An easily-made spring socket connector.

the aerial connection is of the plug and socket type, and, of course, the terminals on the additional condenser are not suitable for the plug. By winding a little coil of No. 20 copper wire on the taper of a lead pencil, a handy spring socket can be made, as shown in the sketch. When this is fitted to the condenser terminal, the aerial can be easily plugged in where required. Similar spring sockets of a smaller type are useful for telephone or other temporary connections.—H. A. STEWART (Glasgow).

**Power Valves in Parallel**

HERE is a simple method of connecting two power valves in parallel when there is not enough space on the baseboard for the extra valve-holder. As shown in the accompanying drawing, the two valve-holders are mounted on a piece of ply-wood with their corresponding terminals connected together, and then fixed to an old valve base (by a screw through the centre). Thin rubber covered flex soldered to the pins is then connected to the terminals of the valve-holders. The valve base I used was rather long, but

VALVE-HOLDERS WIRED IN PARALLEL

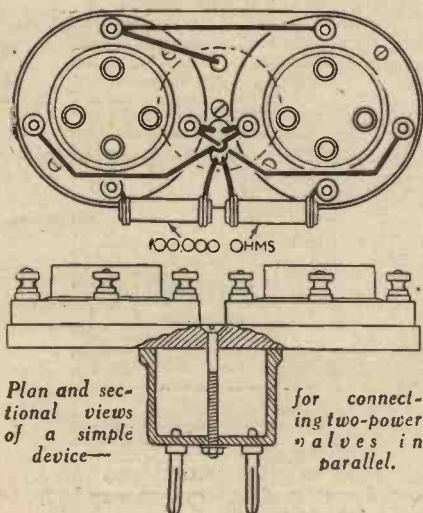

Plan and sectional views of a simple device for connecting two-power valves in parallel.

**THAT DODGE OF YOURS!**

Every reader of "PRACTICAL WIRELESS" must have originated some little dodge which would interest other readers. Why not pass it on to us? For every item published on this page we will pay half a guinea. The latest batch is published below. Turn that idea of yours to account by sending it in to us, addressed to the Editor, "PRACTICAL WIRELESS," George Newnes, Ltd., 8-11, Southampton Street, Strand, W.C.2. Put your name and address on every item. Please note that every notion sent in must be original. Mark envelopes "Radio Wrinkles."

I cut this shorter so as the whole thing should not be too high when plugged into the valve-holder of the set. I afterwards de-coupled them by connecting a 100,000 ohms resistance in each grid lead, and found it a great improvement.—W. J. PALMER (Southsea).

**Morse Code Practice Set.**

THIS hook-up will enable anyone to master the code quickly, with a few minutes' practice daily. The signals

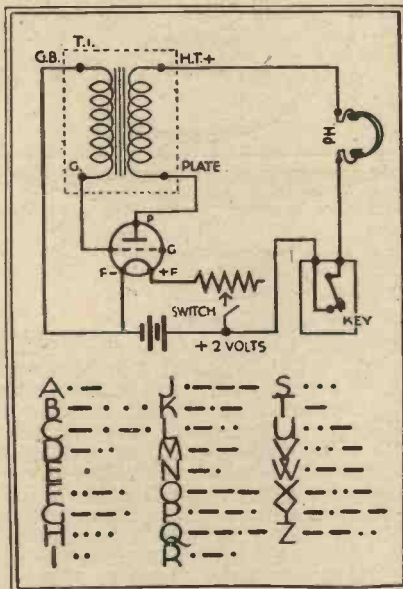

A simple method of practising the morse code.

sound exactly like those heard in ordinary radio transmissions, the 60-ohm rheostat R. 1 regulating their tune. The accompanying diagram shows how the various components are connected up. Almost any valve will do. If the set does not work at first, after checking over the diagram, reverse the leads to G and Plate on the

transformer. Any L.F. transformer with a ratio of 3½ to 1 will answer the purpose, while the tapping key is a standard pattern.—R. MCKINNON (Glasgow).

**Bending Strips for Sheet Metal**

NO home wireless workshop can be complete (particularly with the modern chassis constructions) without a pair of bending strips. These strips are quite easily made from two pieces of bright drawn mild steel strip, 1ft. 6in. long, 2in. wide and

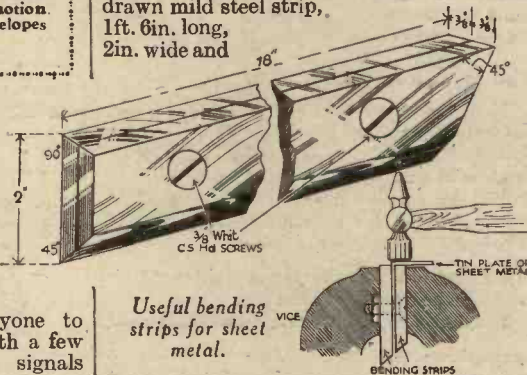

Useful bending strips for sheet metal.

½in. thick. One edge, and also one end, should be drawfiled perfectly level and square. The opposite edge should be filed to an angle of 45 degrees, and the opposite end to 45 degrees; and the two strips fixed together with two ½in. Whitworth C.S. head screws, about one inch long. The strips are then complete, as shown in illustration. The metal to be bent is screwed firmly between the strips, and the whole held between the jaws of a vice, as shown. After bending the metal over with the hands, it is finished off with a light hammer. The result is a first-class sharp edged bend.—C. CROWLEY (Birmingham).

**A Turntable for Portable Sets**

MANY portables, especially those of the attache case type, are not fitted with a turntable, and it is no light task to keep turning one round for best aerial direction. To make the turntable shown in the accompanying sketch, all you require is a 10in. or 12in. gramophone turntable, the spindle from same, and a wooden baseboard about 12ins. square and ½in. thick. The spindle is cut down to about 3in., and if possible a BA screw thread put on one end. At the baseboard centre, drill a hole (but not right through) and screw spindle into it. It can be secured with lock-nuts. The turntable is put on the spindle, which,

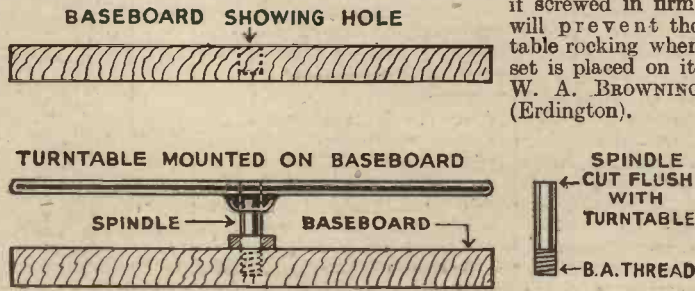

A strong turntable for a portable receiver.

if screwed in firm, will prevent the table rocking when set is placed on it. W. A. BROWNING (Erdington).

**Tightening Nuts in Awkward Corners**

WHEN wiring a set, trouble is often experienced when screwing up the nuts of the components. In awkward corners space will not permit the use of a pair of pliers, and to get over this difficulty the following idea will prove very useful. Get a fairly long screw-driver, or something to serve the purpose, about  $\frac{1}{4}$  in. wide at the blade, and file it as shown in the diagram.

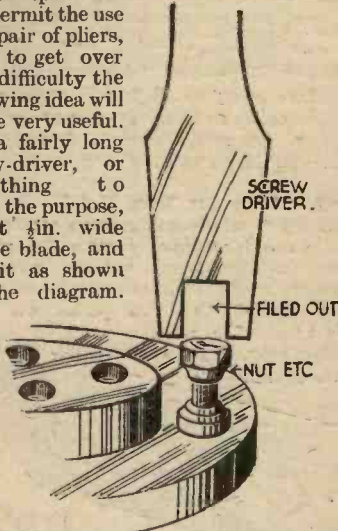

A useful dodge for tightening nuts in awkward places.

It is then an easy matter to tighten up the nuts, using the tool as you would an ordinary screwdriver.—E. G. WHITE (Southampton).

**Adjustable Grid-leak Holder**

ALL you require to make this holder is a small strip of ebonite and two telephone terminals. First bore a hole near one end of the ebonite strip and cut a slot in the other end as shown in the accompanying diagram. Slip the terminals

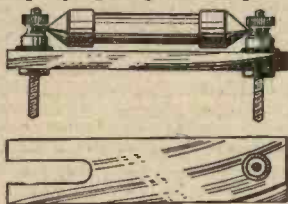

A novel adjustable grid-leak holder.

in place and the holder is finished. The slot in one end allows the holder to be adjusted to fit any grid leak.—FRANK TURNER (Everton).

**Economising in H.T. Current**

A GOOD way to reduce the H.T. current in battery sets is to put a three-pole double-throw switch on the panel to enable one to use a power or super-

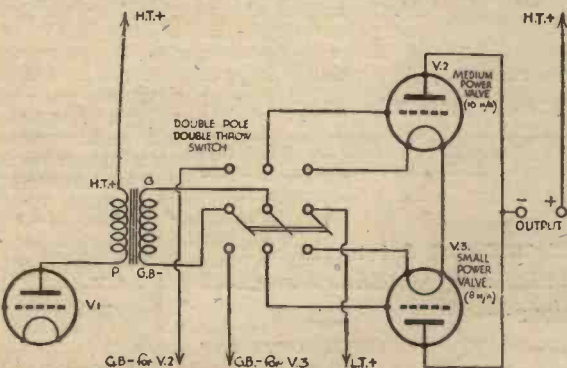

A switching arrangement for power valves.

power valve at will. I use the power valve when listening to a talk, or the News Bulletin. Also, when listening to foreign stations which require much reaction, or suffer from fading. Dance music sounds much more natural and has more body to it when the last valve is using 2 2/5 watts instead of 1 1/5 watts, as would be the case when using a small power valve.

Judging from the few friends of mine whose hobby is radio-set building, etc., a number of readers may already have a small power valve by them which is not in use.—STANLEY CARTER (Lepton).

**Locating Stations**

A USEFUL dial indicating device can be made as follows:—Remove dial and cut slot  $\frac{1}{4}$  in. by  $\frac{1}{4}$  in. and taper back as shown. Cut a white paper disc the same diameter as the dial and paste same on panel before replacing the dial. Once the station is found and marked in the slot of dial, there is no need to trouble about the wavelength or degrees on the dial.—GEO. S. ROME (Shandon).

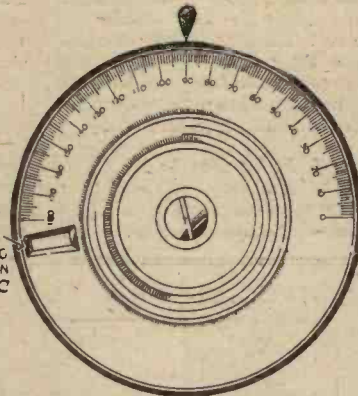

Adapting a dial for indicating stations.

**An Auto-coupling Unit**

IT is well known that the characteristics of the low-frequency transformer are much improved if the anode current is prevented from flowing through the primary winding. One way of doing this is to employ the new well-known method of filter-feed. Another way is the auto-coupling method, which is really a development of the above system. It is, therefore, thought that the auto-coupling unit, shown in the accompanying sketches, will be of interest. The unit is made up from an old L.F. transformer, a fixed condenser and a 30,000 ohm resistance. A small wooden base should be made for these components, because it is then much easier to put them into the set. The base is provided with terminal strips, as shown, and when all is in place, connect up as follows:—

Transformer, P to G.B.; H.T. to G.B. on terminal strips, and G to G on strip. A wire is also taken from transformer P to fixed condenser. One side of resistance is connected to terminal strip

H.T.+, and the other side to P. and one side of condenser. The connections to the set are the same as in the case of an L.F. transformer.—A. S. RICHARDS (Bargoed).

**Protecting a Metallised Valve**

WHERE a metallised S.G. mains valve is mounted through a screen, there is danger of the valve coming in contact with the screen, thus short-circuiting the bias resistance, and causing the valve to be run

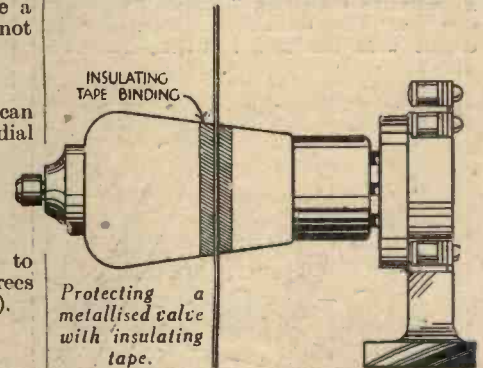

Protecting a metallised valve with insulating tape.

without bias. This can be obviated by binding the portion of the valve likely to touch the screen with insulating tape, as shown in the sketch.—R. SHARMAN (Wickford.)

**That 12-volt Dry Cell!**

In our Dec. 10th issue, on page XII of the Christmas Supplement, an inscription to one of the diagrams reads: "A 12-volt dry cell is a useful stand-by." "A single 2-volt cell was, of course, intended, as was shown in the diagram. The slip, which of course was obvious, is really too bad, but we do try!"

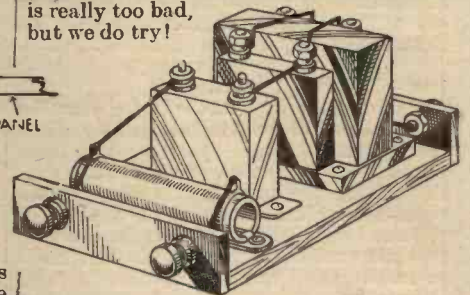

Perspective view of the complete auto-coupling unit.

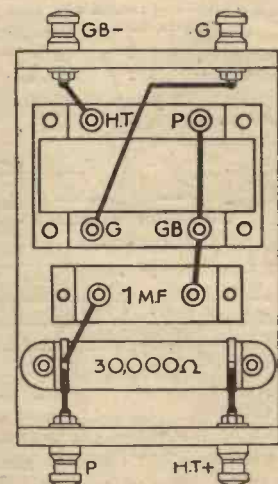

Plan view of the auto-coupling unit.



# Another Experimental Baseboard

FOR the constructor who delights in carrying out tests of various circuits, one cannot do better than to use an experimental baseboard, such as the one here described.

With its aid numerous circuits can be wired up and tried out with such rapidity as to enable him to explore fully into the fields of this fascinating

hobby. Taking a glance at Fig. 1, it will be seen that this consists of a wooden tray into which a number of square blocks fit, producing a baseboard divided up into equal squares. The number of blocks can be such as will cover the constructor's requirements, but for general utility the writer has found that a board 27in. by 12ins. by  $\frac{1}{4}$ in. thick, having thirty-six blocks, 3ins. square, is large enough to cover a wide range of circuits ranging from one to four valves. Actually several more blocks are needed, on which to mount other components that may be on hand. The construction of this board is simplicity itself, the illustrations being self-explanatory.

### Details of Construction

First of all take the bottom board and

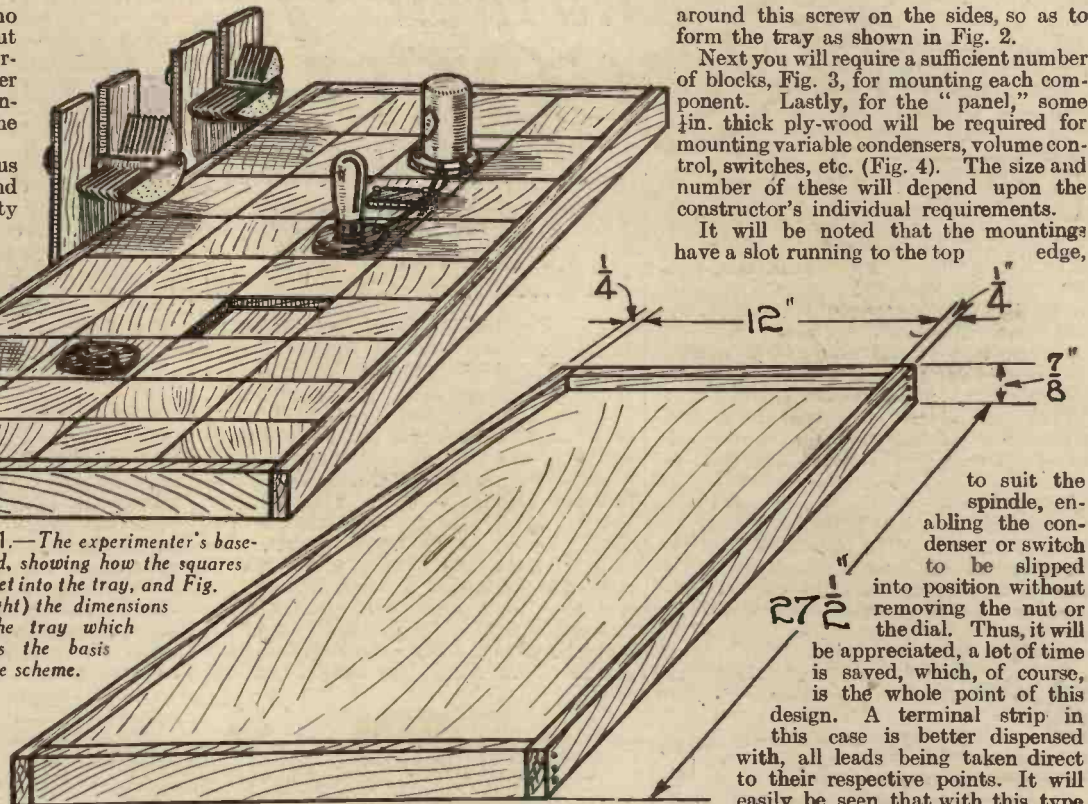

Fig. 1.—The experimenter's baseboard, showing how the squares are let into the tray, and Fig. 2 (right) the dimensions of the tray which forms the basis of the scheme.

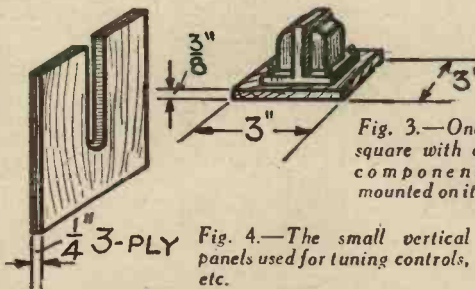

Fig. 3.—One square with a component mounted on it.

Fig. 4.—The small vertical panels used for tuning controls, etc.

around this screw on the sides, so as to form the tray as shown in Fig. 2.

Next you will require a sufficient number of blocks, Fig. 3, for mounting each component. Lastly, for the "panel," some  $\frac{1}{4}$ in. thick ply-wood will be required for mounting variable condensers, volume control, switches, etc. (Fig. 4). The size and number of these will depend upon the constructor's individual requirements.

It will be noted that the mountings have a slot running to the top edge,

of experimental board rapid replacement and disposition of components is conveniently effected by disconnecting their leads and lifting out the components complete with their mounting blocks. Also, in the case of a circuit using two L.F. transformer stages, one of the transformers can be turned round so as to bring the windings into opposition. Finally, each component can be extracted or replaced without interfering in any way with the wiring of the remainder of the circuit.

THE evil effects of dust evidence themselves in a variety of ways.

Poor signal strength, fading, crackling noises, etc., so often attributed to causes outside the control of the user of the wireless receiver will, in many cases, be found to emanate from an accumulation of dust which has perhaps been lying hidden for some time. With the old-fashioned types of sets using horizontal panels, on which were mounted nearly all the components, the effects of dust were most marked, but since the dust was plainly visible to the eye, generally it was removed before making itself very troublesome. The modern type of set, frequently all enclosed, is just as susceptible to the evils of dust, however, and it is surprising how particles have an uncanny knack of getting inside the cabinet. The spaces between the variable and fixed condenser plates are cleaned easily with a feather or pipe-cleaner, but for thoroughly

## AWAY WITH THAT DUST!

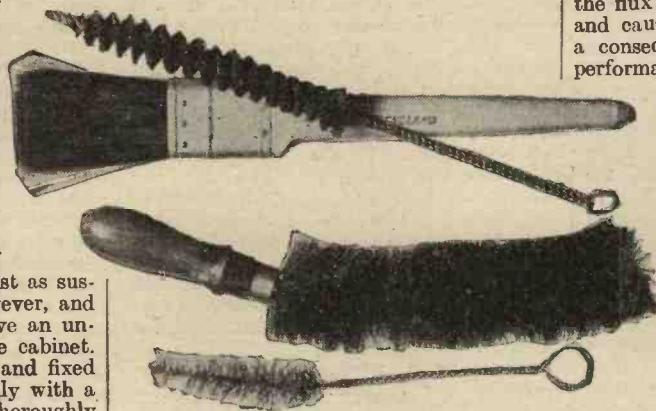

cleaning the set interior generally, special types of brushes are desirable. When soldering, the flux should be used sparingly, and any superfluous flux wiped away as soon as the electrical joint is made. If not, the flux will collect dust particles readily, and cause a leakage between joints, with a consequent upsetting of the receiver's performance.

### Some Useful Brushes

To carry out the "spring cleaning" one requires a good camel hair brush about 1in. wide across the end. Then, in addition, there is marketed a very good soft brush, appropriately designated a "wireless brush." The hairs are held in a spiral of wire, and thus give a cylindrical formation about  $\frac{1}{4}$ in. to  $\frac{1}{2}$ in. in diameter. The hairs close up to a very narrow thickness, however, and this enables one to get into awkward places.

# Receivers and their Records

We shall be glad to advise readers regarding purchase of complete sets

IN reality, this powerful short-wave receiver comes to you as a kit of components, but it is so easy to build that it is possible to construct it in the course of an evening or so. For the purpose of the test, a ready assembled receiver was sent to us, but from a study of the circuit, and the clear instructions and blue print given with it, there is no doubt that even a beginner can put it together without difficulty, and make it work efficiently.

The "Kilodyne" is a well-thought-out four-valver specially made for the reception of all wavelengths between 12.5 and 85 metres, but also possesses the advantage of being adaptable by the use of extra coils for tuning in stations in any waveband up to 1,800 metres. The construction of the receiver has been greatly simplified by the use of a perfectly straight circuit. The aperiodic aerial stage consists of a high-frequency choke between the grid of the screen-grid valve and earth; this valve is coupled to the detector by means of a high-frequency transformer, of which only the secondary is tuned with a .00016 low-loss variable condenser. (It is thus possible to adopt an untuned aerial circuit with success, and to reduce the tuning controls to a bare minimum of one.) With such an efficient form of coupling, selectivity is very good, as there is only a light damping due to the load of the secondary winding on the detector valve. To obtain reaction, a winding is fed from the detector plate to the high-frequency transformer by the Reinartz method. Leaky grid detection has been employed. The metallized detector is followed by one low-frequency (resistance-coupled) stage, using a valve of high amplification type and a Ferranti AF8 transformer feeding a pentode output valve. From this description you will see that the "Eddystone Kilodyne Four" represents a powerful receiver, capable in many instances of giving loud-speaker reception of the most important short-wave broadcasts.

## Maximum Efficiency

The set has been designed for maximum efficiency around the valves which are specified by the makers, and it is important to adhere to their choice; in particular, it was found that for the satisfactory operation of the circuit the use of a Mazda HL210 metallized in the detector stage was highly important. There are four special Eddystone 6-pin coils supplied with the kit, and each one is marked with a different colour spot to facilitate recognition; they cover 12.5 to 28 m.; 24 to 50 m.; 40 to 85 m., and 260 to 550 metres, thus allowing

## EDDYSTONE KILODYNE FOUR

the user to tune in transmissions on the broadcast band. Although, in the last case, the coil may be found useful, selectivity, in the neighbourhood of a powerful station is not of a high order, and very careful tuning is necessary if the local broadcast is to be cut out. The "Kilodyne" is essentially a receiver for short waves, and under test proved its great value in this particular sphere. In appearance the receiver is simplicity itself; open metal chassis, with sloping front, its single tuning-control flanked on each side by the reaction knob, and the "on" and "off" switch looks business-like. The dial behind the esutchon is clearly marked in degrees; the control knob is of generous proportions

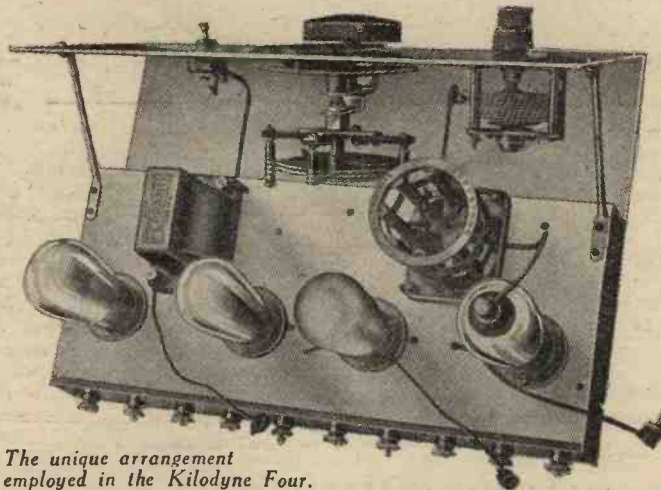

The unique arrangement employed in the Kilodyne Four.

and, as it works on a friction drive tuning is an easy matter. For the capture of broadcasts on short waves, slow motion is a necessity; it is so easy to pass over a carrier wave, and it is essential that tuning should be direct and precise, also that reaction should be smooth. In these matters the "Kilodyne Four" excelled and, moreover, the set did not suffer from body capacity effects. It was found possible to capture a signal, and to hold it for long periods, without any further adjustment of the controls. The "Kilodyne Four" has been essentially designed for high-tension battery feed; notwithstanding its four valves, its H.T. consumption did not exceed 15 milliamperes; low-tension current taken from a 2-volt accumulator was 0.6 amp.

If good results are to be obtained, it is a *sine qua non* condition that the valves should get their right amount of H.T.

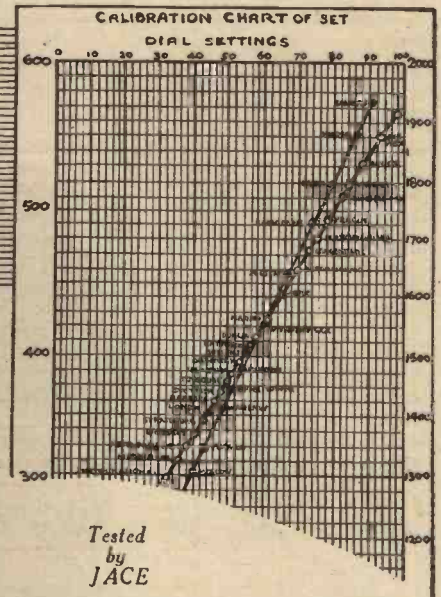

Tested  
by  
JACE

current, and reliable high-tension batteries should be used. If loud-speaker reproduction is desired at good strength, up to 150 volts (with a grid bias of 15 volts) may be fed to the pentode valve, and 110 or 120 volts to the first L.F. stage. Experiments proved that, where stations were weak and distant, a low voltage was preferable to the screen-grid valve; the makers recommend 70-80 volts, but under test more broadcasts were logged when voltage, in this stage, was reduced to 30-40 volts. This is a question of experiment; the main object is to choose voltages on the screen-grid and detector valves which will secure perfectly smooth reaction, and which will allow you to use reaction easily just under oscillation point, and thus keep the receiver stable. In the long run, it is more economical to use double- or triple-capacity high-tension batteries; for these tests both Drydex and Pertrix ultra capacity units gave excellent results.

There is a knack in tuning a short-wave receiver which the beginner must first acquire. If signals are to be heard the set must not be allowed to oscillate; it must be kept just below that point. Start by putting the reaction control at its lowest point, then, whilst tuning slowly, gradually increase by turning the vernier knob very slowly clockwise. At a certain setting the receiver will begin to oscillate; you will notice this by hearing a peculiar "rushing" noise. Continue to turn the tuning dial slowly, increasing the reaction gently keep the set in this condition. If you come to a carrier wave, you will hear a slight "squeal" or "cheep." Possibly it may only be a Morse transmission, but this will give you the necessary intimation. A broadcast telephony carrier-wave provides the same kind of noise, but before you can hear telephony the dial must be gently turned until, as it were, you get into the trough of the wave. Ease off reaction, and again re-adjust dial, when the speech or music should be audible. It simplifies the operation to keep it in a condition of oscillation, but bear in mind that telephony

(Continued on page 710.)



## "The set seemed to jump to life"

FROM all over the country we are receiving letters like the one here reproduced—sure proof that **Cossor Screened Grid Valves** definitely give improved performance. Why put up with indifferent radio? Why continue to deprive yourself of the full capabilities of your Receiver? Widen your choice of programmes—bring in those stations which, now, are merely whispers—equip your Set with **Cossor**, Britain's most efficient **Screened Grid Valves**.



—user's striking tribute to the efficiency of **Cossor S.G. Valves**

Liverpool

Dear Sirs,

Three weeks ago at a very interesting part of a broadcast, my screened grid valve went out of action. I went to a wireless shop for the same make I had been using (foreign) but they had none in stock. They advised me to try **Cossor** so I purchased one. I put in the metallised S.G. valve and when I switched on I got a surprise.

The set seemed to jump to life. I heard instruments that I had never heard before and the artistes sounded as if they were in the next room. Even the loud speaker sounds 100% better and foreign stations come in much clearer.

All my friends agree that the **Cossor S.G.** valve has improved my reception. In conclusion I might say that I intend replacing all the valves with **Cossor**.

Yours faithfully,

Sgd. \_\_\_\_\_

# COSSOR

## SCREENED GRID VALVES

Send for a free copy of the 40-page **Cossor Valve and Wireless Book** which contains a wealth of interesting and useful information including **Radio Definitions—Useful Circuits—List of Stations, etc., etc.** Please use the Coupon.

To **A. C. COSSOR LTD.**, Melody Department, Highbury Grove, London, N.5.  
Please send me, free of charge, a copy of the 40-page **Cossor Valve and Wireless Book B.17.**

Name \_\_\_\_\_

Address \_\_\_\_\_

My usual Retailer is \_\_\_\_\_

Address \_\_\_\_\_

The original of the testimonial above reproduced may be inspected at our Head Office, **Cossor House, Highbury Grove, London, N.5.**

**A. C. COSSOR LTD.**, Highbury Grove, London, N.5. Depots at Birmingham, Bristol, Glasgow, Leeds, Liverpool, Manchester, Newcastle, Sheffield, Belfast, Cardiff and Dublin. 2087

# A SIMPLE GALVANOMETER FOR TESTING

By  
A. E. OAKLEY

ONE of the handiest testing instruments is the galvanometer. The best form is, of course, the standard "linesman's galvo," which is in regular use by telephone linesmen, mains engineers, etc. A perfectly good and practical galvanometer can be made, however, on the simple plan here explained, and it is quite certain that, once made, it will be in continual requisition.

The basis of the instrument is a cheap compass. Many readers will have one of

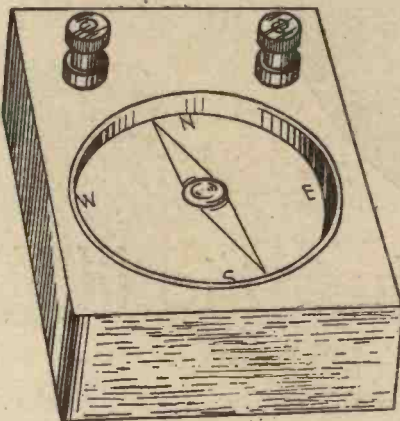

The complete Galvanometer.

these on hand; if not, one may be purchased at electrical stores, toy shops or junk stalls. The diameter may be from 1 in. to 1½ in. Assuming we have located one of, say 1½ in. diameter, we shall require, for the base, a square of hardwood 2½ in. by sufficient thickness to accommodate the compass, coil and magnet as shown in the illustrations. The compass should be a push fit. The coil is wound on a strip of fibre (or cardboard dipped in wax) ½ in. wide. The most useful all-round winding will be to fill the strip with about eight or nine layers of No. 40 swg. silk covered. Actually, any wire from 36 gauge upwards will make a delicate instrument, but a high resistance is a great advantage, for it enables the galvanometer to be used universally on L.T. or H.T. circuits. So if you have wire available from an old transformer or choke (usually about 47 gauge), by all means use

it. 40 swg. will give a resistance of 150 ohms or more; 47 swg., 800 to 1,000 ohms. Dip the coil in wax after winding. The base is notched out at the back to receive the coil (which is a little longer than the compass diameter) and also the magnet, which is put in last at right angles to the coil. This latter is made from any odd steel strip, such as a piece of clock spring, two or three pieces of watch spring, or a piece of the round silver steel used for drills. If the latter is used, it may be of ⅜ in. diameter, with a flat filed on opposite sides so that it does not occupy too much depth in the base. After filing it should be hardened by heating to bright red and quenching in water. Clock spring or similar material is already "dead hard." The steel is magnetised by drawing one pole of any permanent magnet along its length several times, or by placing it inside a coil through which a current is passing. Tapping the steel occasionally while being magnetised assists the operation.

The coil ends are connected to two terminals, and the under side of base covered by pinning or gluing on a piece of cardboard. The latter may be faced with a piece of cloth to give a suitable finish. A touch of varnish or french polish completes the job.

## Using the Galvo

When using any electrical instrument, its resistance and current-carrying capacity must always be considered, for to connect a low-resistance winding to, say, a 150 volt accumulator may result in damage not only to the instrument itself, but to other apparatus in the circuit. The present instrument, if wound to the fairly high resistance suggested, may be used pretty freely. It will never, of course, be permanently connected to the current, but a momentary contact made. It is not a precise measuring instrument, but has this advantage over flash lamps, 'phones, etc. It is exceedingly delicate, responding to a very small voltage or current; and yet

robust, for it may be "flicked" on the H.T. without damage, and will not hurt one's eardrums as 'phones often do when testing. Its principal use is for continuity tests, and it can be placed in filament or anode circuits to check that a current is flowing, and its direction. Used with an accumulator or flash lamp battery, transformers, chokes, etc., may be tested for continuity, and, using a higher voltage, suspected condensers or other components for insulation breakdown or "shorts."

## A Polarity Indicator

The compass needle is normally held at zero by the magnet, and the terminals are mounted on the base in such a position that the needle points midway between



Section showing positions of compass, coil and magnet.

them. When a voltage is applied to the terminals the needle will, therefore move left or right according to the direction of the current. It is most convenient to arrange the coil so that the needle will always point towards the positive terminal. This is determined before fixing the base cover by connecting an accumulator. If

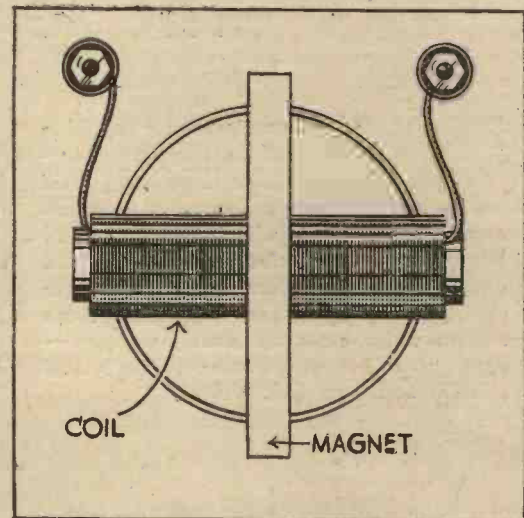

The underside of base, showing connections to terminals.

the needle moves in the wrong direction, simply reverse either the coil or the connections to the terminals.

## Simplifying Soldering

(Continued from page 680.)

actually soldering the joint, and furthermore saves the solder from getting lost. A little extra refinement, but one well worth while, is the addition of four small soft rubber feet on the underside of the baseboard—one at each corner.

For the actual work of soldering the joint only a few words are necessary. Say it is part of the wiring on your set. First of all "tin" the iron as described earlier and then tin the soldering tag or tags

where the wire has to be connected. This is done by smearing a little flux on the tag and touching it with the heated copper bit until the solder "runs" on the tag end. Now add a little flux to the end of the wire, place it on the tag and then hold the heated copper bit on the two until the solder runs round the wire and tag. Remove the iron, and when the solder has cooled (this is quite a rapid process), the wire will be found to be held rigidly in place. Now clean away any superfluous flux and the job is done. Actually it takes longer to describe than to carry out.

The golden rules for soldering may be summed up quite simply. First of all use a non-corrosive flux and be very sparing in its use at the joints (its function was described earlier in this article). Secondly, do not overheat the iron, or constant tinning will be necessary, and thirdly, see that the surfaces to be soldered are scrupulously clean—rub up with a file or glasspaper if necessary. Having studied these few hints go straight away and try your hand at soldering and you will be surprised how simple it is and how workman-like your finished work becomes.

# A SHORT-WAVE SUPERHETERODYNE CONVERTER

FRANK PRESTON, F.R.A., Here Gives Complete Details of a Simple Instrument with which You Can Convert Your Set for Use on the Short Waves.

IN a previous article published in these pages I explained that there are two ways of using a normal broadcast receiver for the reception of short-wave stations. One of these is to replace the detector and tuning circuits by a single-valve short-wave set made in the form of a plug-in adaptor. The other is to employ a combined detector-oscillator valve in conjunction with the complete set. This latter, generally referred to as a converter, makes the receiver into a short-wave superheterodyne. The "converter" method provides the more sensitive arrangement and is ideal when the set has one or more S.G. stages. It also gives easier control, because the reaction condenser does not require to be operated in conjunction with the tuning condenser, as is the case with most kinds of S.W. receivers. As a matter of fact, it is just as easy for any member of the household to operate the complete short-wave superheterodyne as to tune in broadcasting programmes on the higher wavelengths.

Realizing that more and more listeners desire to make use of the short waves, and yet do not wish to go to the expense of a completely new set, I have designed the simple, and extremely efficient, short-wave superheterodyne converter, illustrated on this page. In addition to its normal function, the unit can, if desired, be employed as a self-contained single valve short-wave receiver. It can be used with any S.G. receiver which is operated by batteries or an H.T. eliminator, and it can also be modified to work in conjunction with an all-A.C. set when necessary.

I do not propose to describe the theory of the converter, for that was dealt with on page 299 of PRACTICAL WIRELESS,

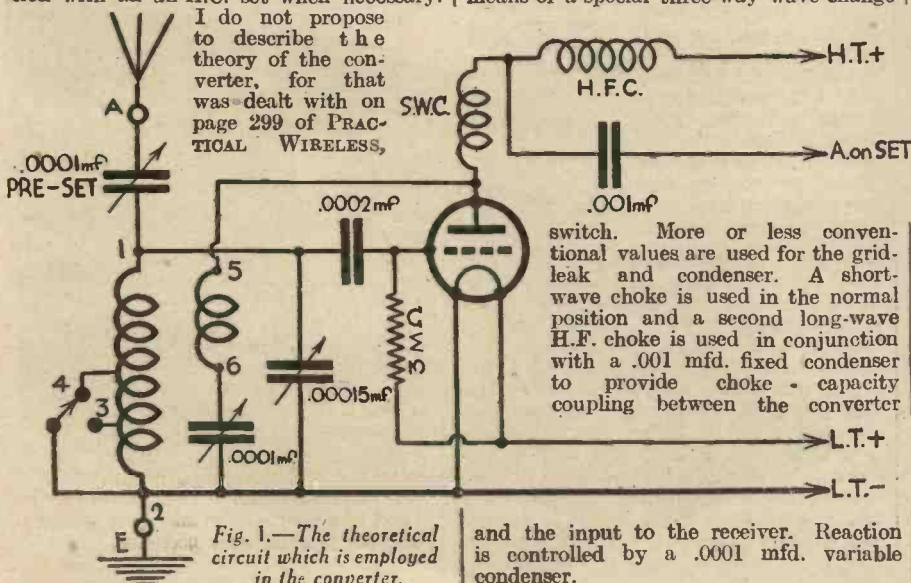

Fig. 1.—The theoretical circuit which is employed in the converter.

No. 6; if you are in any doubt regarding this point please refer back to the latter article.

### The Circuit

Before passing on to the constructional details, let us just glance over the circuit diagram of Fig. 1. We note that the aerial is connected to the "top" end of a three-range tuner through a .0001 mfd. pre-set condenser. The tuner, being tapped in two places, provides a total tuning range of from about 15 to 80 metres when tuned by the .00015 mfd. variable condenser. This range is divided up into three of 15-25, 25-45, and 45-80 metres respectively, the different ranges being obtained by means of a special three-way wave-change

switch. More or less conventional values are used for the grid-leak and condenser. A short-wave choke is used in the normal position and a second long-wave H.F. choke is used in conjunction with a .001 mfd. fixed condenser to provide choke-capacity coupling between the converter

and the input to the receiver. Reaction is controlled by a .0001 mfd. variable condenser.

Fig. 3.—The neat and compact layout may be seen from this photograph.

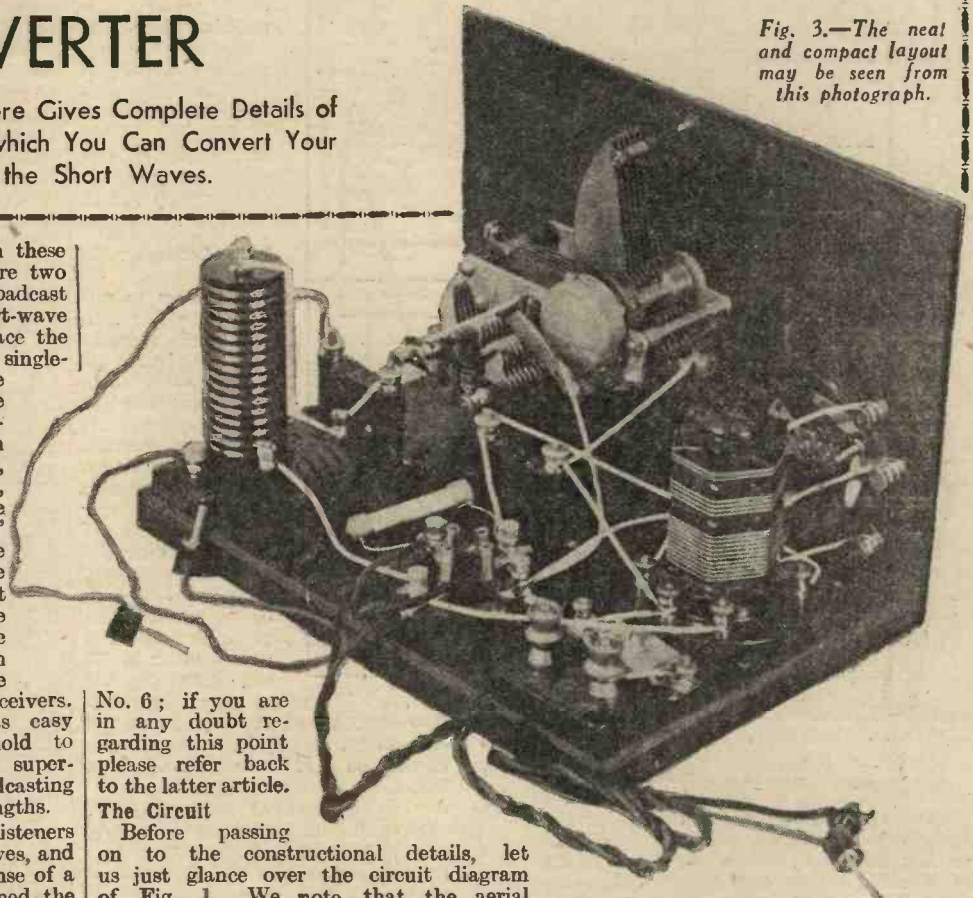

### Choice of Components

A list of components required is given elsewhere. It is absolutely essential to keep to the parts specified, but in case you have a few parts on hand I will point out where alternatives are permissible. Obviously the tuning coil and associated wave-change switch could not be replaced without spoiling the whole design, but alternative makes could be used for most of the other components, provided that they have similar characteristics and are of equal quality. But if you are going to buy new parts, insist on being supplied with those specified because they have been carefully chosen to work together. At the same time their prices are in most cases lower than those of other components of equal quality.

### Construction

This is extremely simple and straightforward, as you will gather by examining the wiring plan of Fig. 2 and the photograph, Fig. 3. The conventional arrangement of panel and baseboard has been followed because this is the best and simplest for a small unit of the kind we are dealing with. First of all prepare the panel and baseboard, drilling the former in the positions indicated in Fig. 2, to take the bushes of the two condensers and the spindle of the wave-change switch. The switch is attached to the panel by two long bolts, with nuts, and the correct positions of the holes for these are best found by using the bakelite flange as a template. You will

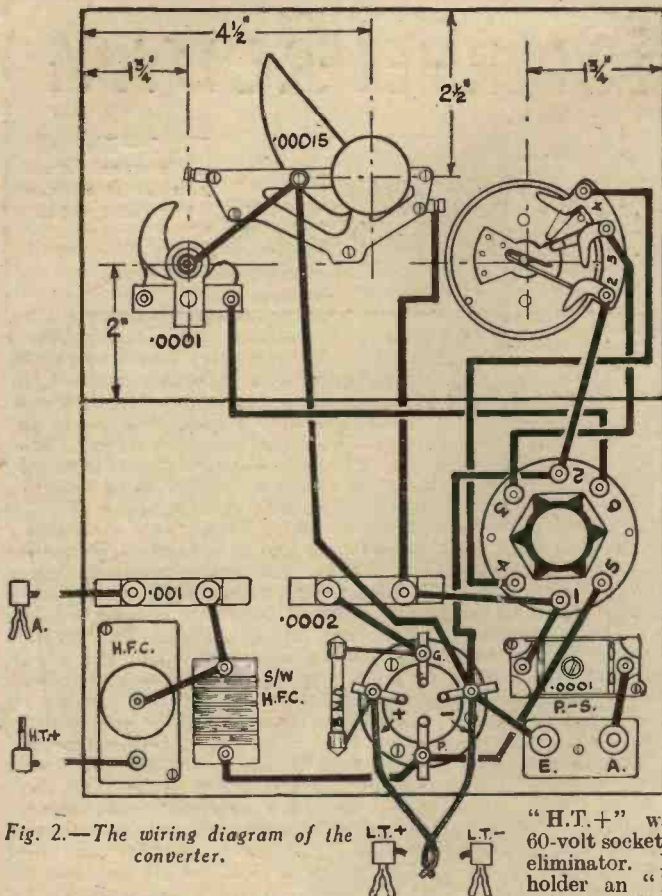

Fig. 2.—The wiring diagram of the converter.

wish to stain and polish the panel, so this should be done before screwing it to the baseboard. Next, lay all the components on the baseboard in the positions shown in Fig. 2; make sure they all fit comfortably in their places before finally screwing them down.

#### Wiring

It will be found easiest to adopt a system in wiring and to work from the right (looking at the back) towards the left. It should be mentioned in passing that the grid-leak is attached to the valve-holder

#### LIST OF COMPONENTS.

- 1 Plywood Panel, 9in. by 6in.
  - 1 Baseboard, 9in. by 6in. by 1/2in.
  - 1 .00015 mfd. tuning condenser, with slow-motion dial (Jackson Bros.).
  - 1 Dial pointer (Bulgin).
  - 1 .0001 mfd. reaction condenser (Jackson Bros.).
  - 1 Triple-range S.W. tuner (Lissen).
  - 1 Triple-range wavechange switch (Lissen).
  - 1 .0001 mfd. pre-set condenser (Colvern).
  - 1 .001 mfd. fixed condenser (T.C.C.).
  - 1 .0002 mfd. fixed condenser (T.C.C.).
  - 1 3 megohm grid-leak, with wire ends (Dubilier).
  - 1 S.W. valve-holder (Eddystone).
  - 1 S.W.H.F. choke (Bulgin).
  - 1 H.F. choke (Lewcos).
  - 1 Terminal block; marked "A" and "E" (Lissen).
  - 1 Wander plug; marked "H.T.+" (Belling Lee).
  - 3 Spade terminals; marked "L.T.+", "L.T.-" and "A" (Belling Lee).
  - 1 length "Glazite" connecting wire, 2ft. twin flex, screws.
- Approximate cost, 37s.  
Also, if required, 1 type 210 H.F. or 210 H.L. metallized valve (Cossor).

terminals by means of its own connecting wires. In attaching the two L.F. leads and spade terminals, notice carefully the negative-positive terminals on the valve-holder (clearly shown in Fig. 2). Keep all flexible leads as short as possible or efficiency will be impaired.

#### The Converter in Use

And now to put the converter into use. First transfer the aerial and earth leads from the set to the appropriate terminals on the converter. Connect the "aerial" wander plug of the latter to the aerial terminal of set, leaving the earth terminal free. Join the two L.T. leads to the filament terminals of a valve-holder in the set. Then put the

"H.T.+" wander plug into the 60-volt socket of the H.T. battery or eliminator. Plug into the valve-holder an "H" or "H.L." type valve, and everything is ready. Due to the method of connecting the L.T. leads, the on-off switch in the set will also be operative on the converter.

Set the receiver to the very bottom of the long waveband, and proceed to tune-in on the converter. Turn the reaction condenser to its midway position, and rotate the tuning condenser as slowly as possible by means of the slow-motion knob only. A whistle will not be heard when a station is being tuned in unless the set itself is in the oscillating condition. After tuning in the first station, try the effect of adjusting the reaction condenser on the converter; unless this is set to the position of oscillation nothing will be heard at all. Having found the best position, adjust the reaction condenser on the set. This latter will act in exactly the same way as on broadcast reception, and can thus be employed as a volume-control.

Lastly, try the effect of tuning the set to a different wavelength. This might make it necessary to alter slightly the tuning of the converter. When the best tuning position for the set has been found it can be left entirely alone whilst tuning is carried out on the converter itself. Although it has been said that the reaction condenser on the converter does not require to be operated at the same time as the tuning condenser, it is sometimes possible to increase the strength of a signal by making a careful adjustment to the reaction condenser. As the valve in the converter must be kept in a state of oscillation a higher reaction setting will be required when receiving on the longer wavelengths. No mention has yet been made of the functioning of the wave-change switch. The knob has a rotary motion, and when turned to the furthest anti-clockwise position it gives the highest wavelength range. When turned through a small angle in a clockwise direction it "clicks" into the secondary position, and then, by turning it a little further, it "clicks" again as it comes into position for the lowest wavelength range.

#### The Aerial Condenser

The optimum setting for the pre-set aerial condenser depends on the aerial in use. If longer than 60ft., the condenser should be screwed back to its "minimum" position, but when a shorter aerial is employed, better results will be obtained by increasing the capacity. It should be remembered that, if the capacity is too great, the valve will probably be prevented from oscillating, and, in consequence, nothing will be heard.

#### The Converter as a Single-valve Receiver

It was mentioned towards the beginning of this article that the converter could, if desired, be used as a complete receiver. As it is capable of bringing in scores of stations at headphone strength, no doubt some of my readers will wish to try it in that way. To do so, all you have to do is to connect a pair of phones between the H.F. choke and the H.T. positive lead. Besides connecting the L.T. leads to the accumulator a wire must be taken from the negative accumulator terminal to the negative socket of the high-tension battery.

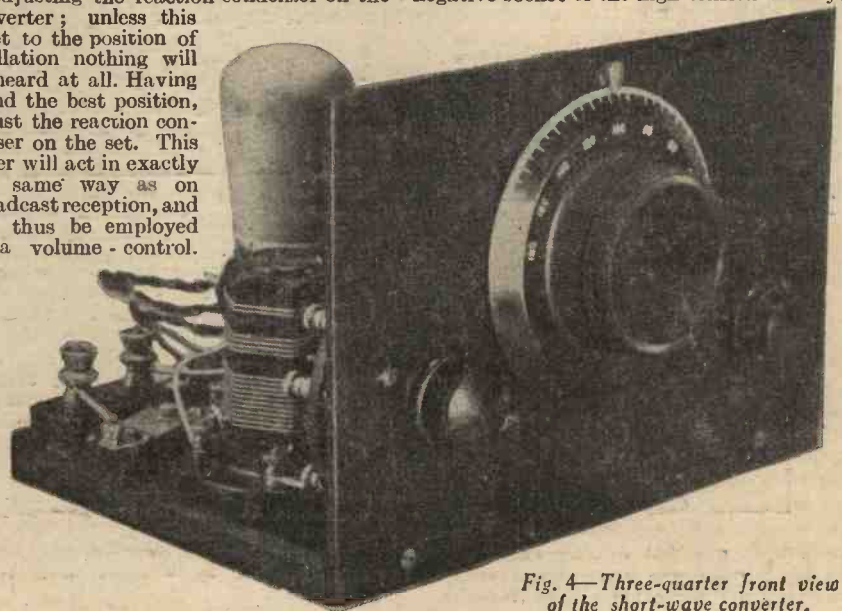

Fig. 4—Three-quarter front view of the short-wave converter.

# WIRELESS IN EVERY ROOM

**T**O have wireless on tap in every room of the house is a phase of wireless enjoyment, the benefits of which are open to all, but realized only by a comparative few. The reason for this is inexplicable, although it may be attributed to the fact that many people think the only way in which it is possible to have wireless reception in every room of the home is to use a portable or transportable set which can be carried about at will. While this very definitely offers one solution, it only

A More Detailed Description of the Arrangements Shown in the Phototone Supplement Presented with the issue dated December 10th

By  
**H. J. BARTON CHAPPLE,**  
 Wh.Sch., B.Sc. (Hons.), A.C.G.I.,  
 D.I.C., A.M.I.E.E.

the next extension position, and so on. This process in effect means taking a loop of wire between the pair of output terminals, and breaking it at the individual loud-speaker extension positions and inserting the chosen connecting device.

### Series Connections

With the series method of working it will be noticed that if any one loud-speaker is removed, the remainder are rendered inoperative, so it is necessary to make an arrangement for short-circuiting each position when the loud-speaker is not in use. A short length of wire or a strap of brass will suffice in the case of a pair of terminals, but with some wall jacks a short-circuiting device is already incorporated. For example, a Bulgin wall jack, resembling externally an ordinary electric light tumbler switch with the knob removed, has a double spring making connection with a metal pillar electrically in contact with the outer cover (see Fig. 3 A). The insertion of a loud-speaker plug opens the prongs of the spring and establishes contact with the plug, thus placing the speaker in circuit. A withdrawal of the plug reverses the process. If ordinary jacks are preferred to the slightly more expensive wall jacks designed specifically for the purpose, then, in the case of a series-extension scheme, use a single-circuit closed jack as indicated in Fig. 4 A. Loop together the long shank and short leaf contact and join the wire at points (a) and (b) as illustrated. An insertion of the plug will then break the circuit as before and re-establish the short on withdrawal. Messrs. A. F. Bulgin supply a complete range of components for the purpose.

The series method of working, while saving wire, is really only suitable for use in conjunction with speakers of similar resistance, and the output valve should have a fairly high impedance for matching purposes—say one of the pentode type. A more popular scheme is the parallel method of wiring shown in Fig. 2 B. Here a pair of wires is taken from the two output terminals of the set to each extension position and linked to the terminals or jack provided. In effect, all the positions are placed in "parallel" electrically, and all the loud-speakers can be in use at the same time if desired, without affecting each other individually. With, say, a Bulgin wall jack, then the metal pin previously referred to is sheathed with an insulating tube so that the double spring is not short-circuited at one end on withdrawal of the plug. If a short circuit does take place, then all the speakers will be out of action.

### Parallel-wiring System

Fig. 4 B shows how the parallel-wiring system can be carried out with ordinary jacks, using in this case the single-circuit open type. In either of these wiring schemes it is necessary when using loud-speakers

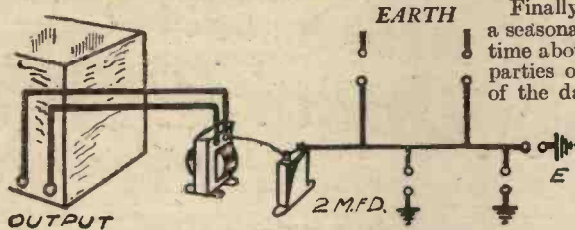

Fig. 1.—An output filter for providing loud-speaker extensions.

allows the programme received to be enjoyed in the particular room in which the set happens to be located at the time. Of course, those outside the room may hear the items if the set is running "all out"; but matters are then unpleasant for those seated in the room, as the volume of sound is too excessive to be pleasant, while coupled with this is the temptation to overload the speaker or output valve (or both), with consequent distortion. These latter remarks apply with equal emphasis to receivers other than portables, so the solution to our problem of being able to listen to wireless reception in every room still remains to be explained.

### Many Benefits Obtainable

Before embarking on this, however, let me suggest a few of the benefits that come to my mind in this connection. First of all, it may be inconvenient to feel that one must be confined mainly to a particular room of the house just because the wireless set is there. As a general rule it is better to locate the set itself in very close proximity to the points where the aerial lead-in and earth wires enter the room. This may be the dining-room, drawing-room, lounge, or even the kitchen; but how nice it would be after enjoying the evening meal to the strains of a delightful orchestra or the voice of a well-known singer, to be able, metaphorically speaking, to transport this to the drawing-room or study, as the case may be! Again, think of a person lying on a bed of sickness, and realize how the long hours of convalescence can be whiled away by a suitable choice of a wireless programme which can be heard in the room itself. The children become a little out of hand in the nursery where they are compelled to play owing to the inclemency of the weather. Why not give them some additional amusement by having a loud-speaker in their room so that they can listen to an appropriate programme? Perhaps it has never occurred to you that the servant problem would be a little less prominent, if it could be pointed out that wireless was available in the kitchen for leisure hours, or when carrying out normal domestic duties.

Finally, to bring the whole matter to a reasonable conclusion, since Christmas-time abounds with the festive spirit and parties or family re-unions are the order of the day, the host has an opportunity of adding still further to his popularity by providing his guests with wireless reception in all those extra rooms which have to be used owing to the increase in family numbers. This time of the year is a most appropriate one to realize how easy it is to confer these benefits on the whole household, at quite a reasonable cost, the actual figure in pounds, shillings and pence varying with individual taste.

### How to Arrange the Wiring

It is just as easy for anyone to have their loud-speakers in every room as it is

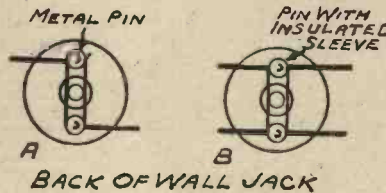

Fig. 3.—The wiring to Bulgin wall jacks.

to have electric light or heat, and the necessary wiring involved can be carried out without damage to the decorations. If it is inconvenient or awkward to run the cable or leads under the floor boards, what better than the top of the skirting or the picture rail? In the Christmas number was shown the interior of a house with the loud-speaker positions indicated, including one for use when weather permits wireless in the garden. First of all let us consider the two simplest methods which can be adopted for loud-speaker extensions, namely, series and parallel wiring (see Fig. 2, A and B). In the series method, Fig 2 A, one wire from an output terminal on the set passes to a connection on a wall jack or one of a pair of terminals mounted on a bracket or ebonite strip. A wire then links the second point on this wall jack or the remaining terminal on the bracket to the first terminal or jack point on

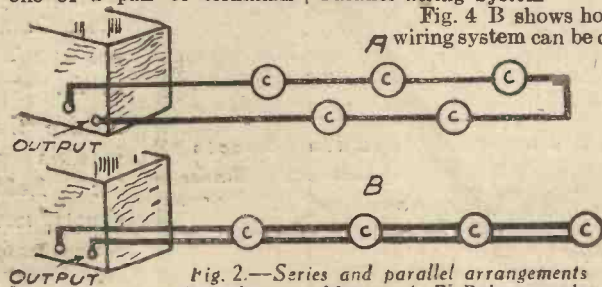

Fig. 2.—Series and parallel arrangements for additional loud-speakers. Messrs. A. F. Bulgin supply every type of plug, switch and jack for this purpose.

(Continued on page 694)

# The Practical Wireless SELF-

## NO GIFT STAMPS TO COLLECT

*Regular Readers  
must not miss this  
Great Opportunity*

These most useful Loose-Leaf Binders, for preserving the Data Sheets which are being given every week, are being expressly made for the purpose and will prove most acceptable and helpful to Radio constructors.

The only way to secure your "Practical Wireless" Data Sheets Binder is to fill in and post the Reservation Form at once. As you will see from the conditions there are no Gift Stamps to collect. If you are a Regular Reader of "Practical Wireless" you are eligible for a Binder, provided of course, you comply with the simple conditions. Your Reservation Form must reach us not later than December 31st, 1932.

N.B.—The date on which the Binders will be ready for despatch will be notified in "Practical Wireless" early in the New Year.

The "Practical Wireless" Data Sheets Loose-Leaf Binder, as illustrated here, has a stout linen covered stiff board cover, specially made to stand hard wear, having a special flap with cloth hinges and enamelled press-button fitting for speedy insertion (and removal) of the Data Sheets which are specially "holed" to fit.

Notice the invaluable manilla gusset-pocket for holding loose sheets, newspaper clippings, notes, and other odds and ends.

The  
**PRACTICAL  
WIRELESS**  
Data Sheets  
Loose-Leaf Binder  
measures 11" x 8"

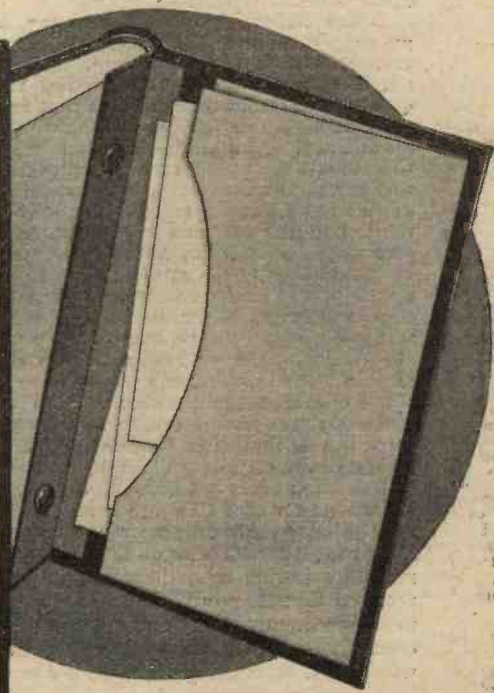
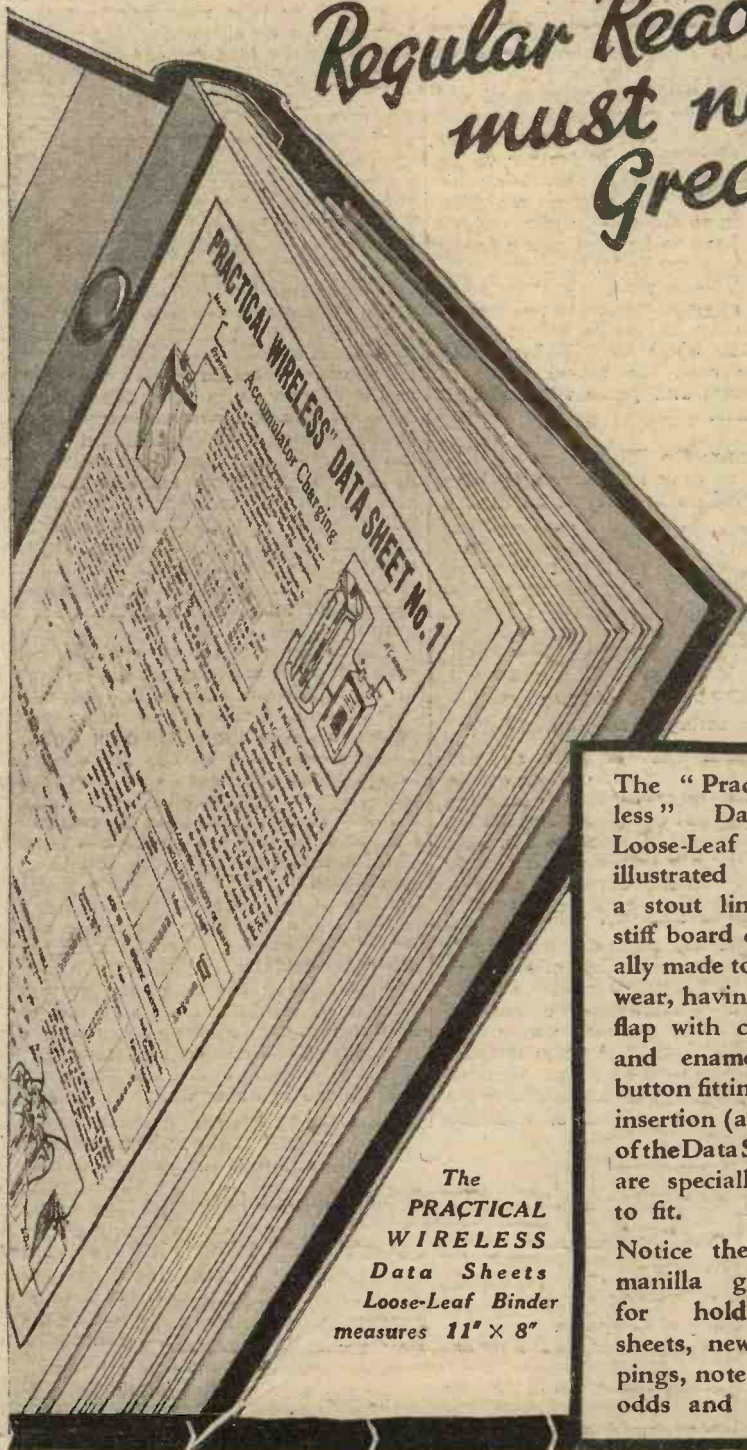



# BINDER *for* DATA SHEETS

These complete and comprehensive Data Sheets have been specially prepared by F. J. Camm (Editor of PRACTICAL WIRELESS) to fill a gap in the literature of wireless construction. They have been designed with the needs of the amateur well in mind; they are printed on a special brand of hard-wearing manilla board to stand up to constant use; they are already punched so that they may easily be slipped into the stout and attractive loose binder which is featured on these two pages and also on the cover of this week's issue. The series, when complete, will provide the home constructor with a means of rapidly surveying the field of wireless construction, operation and adjustment, and enable you by a mere flick of the finger to consult that fact, figure or formula which formerly you have not easily been able to find. The compiler has been to great trouble to collect the facts and to present them in an easily consulted form.

The Sheets give further evidence of the fact that PRACTICAL WIRELESS, with its new policy of catering specially for the needs of the home constructor, exists primarily to serve its readers. The facts are arranged in At-a-glance form. The Data Sheets themselves may be summed up in the phrase—**KNOWLEDGE IN A NUTSHELL.**

The next seven Data Sheets will deal with the following subjects:

- No. 3.—Resistances.
- No. 4.—Mains Transformers.
- No. 5.—Wire and Wire Gauges.
- No. 6.—High- and Low-Frequency Chokes
- No. 7.—Condensers and Condenser Values.
- No. 8.—Battery Eliminators.
- No. 9.—Screws and Screw-threads.

Other titles will be announced in due course.

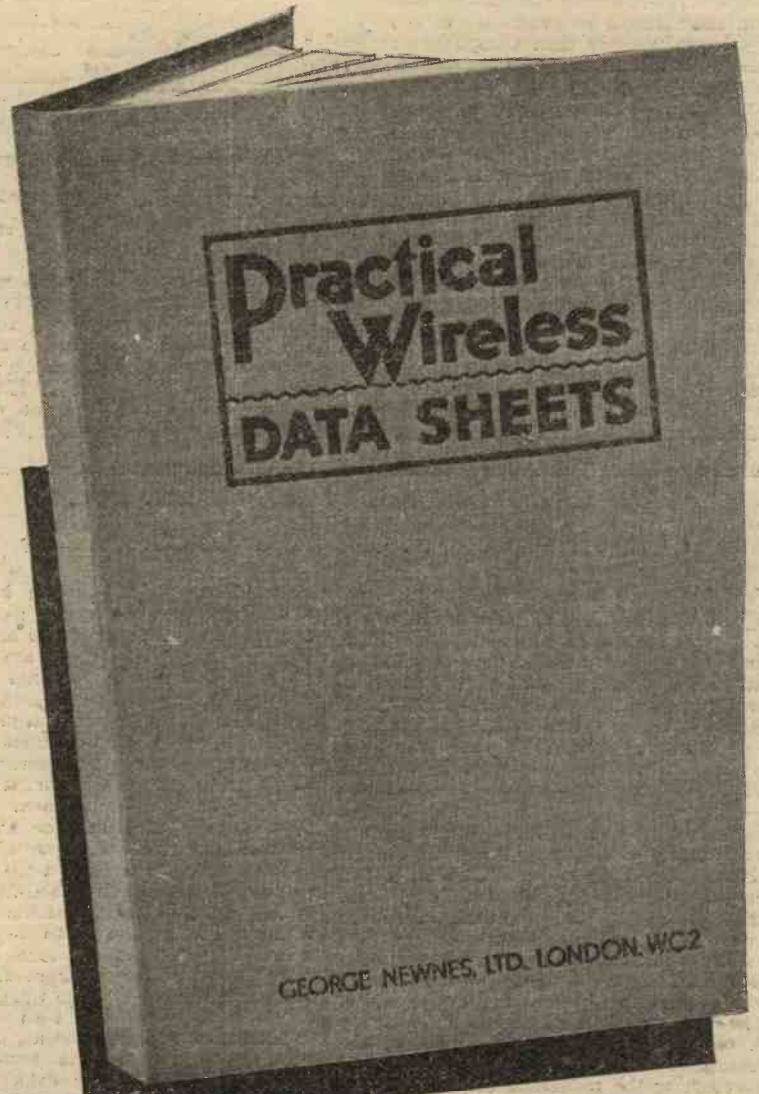

## READ THESE SIMPLE CONDITIONS

*There are no Gift Stamps to collect*

To qualify for your Data Sheets Binder you must complete and sign the Reservation Form on this page, and if you have not already done so, give your Newsagent an order to deliver (or reserve) a copy of "Practical Wireless" every week. Send your Reservation Form to "Practical Wireless," Presentation Department, 39, King Street, Covent Garden, London, W.C.2.

When your Reservation Form is received, and directly supplies of Binders are available (readers will be notified by an announcement in "Practical Wireless"), each applicant will be required to forward a postal order for 1s. 6d. to include registration, postage, packing, insurance, etc. Immediately on receipt of this, your Binder will be despatched.



**COMPLETE AND POST TO-DAY RESERVATION FORM**

### RESERVATION FORM *for* P.W. DATA SHEETS BINDER

*No acknowledgment of this form will be sent.*  
In accordance with the conditions of your special offer, please reserve for me one "Practical Wireless" DATA SHEETS BINDER.

Reader's Name.....

Full Address.....

The Newsagent who supplies me weekly with PRACTICAL WIRELESS is:—

Name.....

Address.....

Leave blank

Reader's Signature..... No.

Post by Dec. 31st, 1932, to PRACTICAL WIRELESS, Presentation Department, 39, King Street, Covent Garden, London, W.C.2, in unsealed envelope (1d. stamp only).

### WIRELESS IN EVERY ROOM

(Continued from page 691.)

with marked polarity to see that corresponding positive positions are linked together with the parallel working, and similarly for the negative leads; while for series working the lead should be such that positive of one point goes to negative of another all the way through. The current through the windings of the loud-speakers will then always be in the same direction.

In my opinion, the best method of all is to use the choke-output filter circuit when contemplating simple loud-speaker extensions. The use of long leads from the output terminals of the wireless set often causes instability, and produces a whistling or howling in the loud-speaker owing to capacity and interaction effects. Furthermore, a proper matching up between the impedance of the valve and the impedance in the anode circuit is really essential if the valve is to work at its maximum efficiency, and the constant addition and removal of a loud-speaker at the extension positions produces a varying load and makes this impossible without the choke. When-

ever possible use an output choke and a 2 mfd. coupling condenser as shown in Fig. 1. Then if it is convenient to make an "earth" connection at each extension position only one wire need be run. The wire is joined to one terminal of the loud-speaker at each listening position, while the second terminal of each loud-speaker is

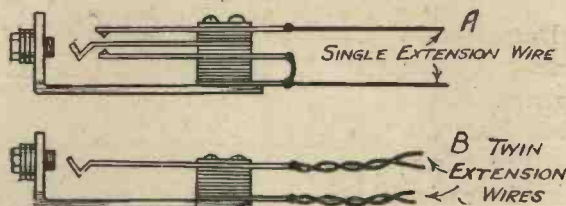

Fig. 4.—The wiring to Bulgin jacks for series or parallel connections.

joined to earth. The earth really forms the return medium to the set in every case, since at the receiver itself the negative H.T. is earthed. Be sure to see that the common point of the coupling condenser and L.F. output choke is joined to the valve plate output, or, of course, the scheme will not work. If it is inconvenient

or impossible to have an earth connection at each listening point, then it will be necessary to link up all these "earth" connections to a return wire passing to H.T.—. When it is desired to have the speaker connected permanently and not have a plug and jack for insertion and withdrawal, it is necessary to include a tumbler or snap switch to put the loud-speaker in and out of circuit. Naturally, this is placed in series with the speaker lead.

The simple schemes just enunciated work admirably, confer a great boon on wireless in the home, and render good service. It may be found that certain wiring runs bring about a trace of hum or noises owing to induction from the house electric mains; but if this happens, just choose a different route for the wire. Alternatively, use lead or any metal-sheathed single or twin cable and earth the outer covering. Obviously, the insulation of any type of extension lead must be above suspicion or a breakdown may occur, and time and pleasure will be sacrificed in locating the fault.

## SOME PRACTICAL PARAGRAPHS

### Cold Light

PERIODICALLY in electro-technical circles the subject of cold light crops up, and there has been such a revival of interest during the past few weeks. Several papers and lectures have been given on the subject, and consideration has been given to the range of gases that glow when current is passed through them. The best known of these gases is neon—the neon sign tubes and lamps being a familiar sight in our streets—but there are very many others which possess similar characteristics to neon. None of them, however, possesses the virtue of cold light. Indeed, most of them are inclined to the infra-red end of the chromatic scale, with a resultant tendency to give off more warmth than light, and a consequent great reduction in efficiency in terms of lighting capacity. The ordinary electric bulb has an efficiency of only about 10 per cent., most of the remainder being taken up in heating and overcoming the resistance of the filament. In our receiving valves the efficiency is not, of course, measured in terms of lighting capacity, although one would have been excused for so thinking in the days of bright emitters. We are only concerned with the electron flow at a given temperature, and the advent of the dull filament was a great stride. Numerous experimenters are continually going on endeavouring to find filaments that will give sufficient emission at even lower temperatures and consequently lower current consumption. At the same time, it must be remembered that current consumption does not assume the same importance nowadays, with the greater use of the supply mains, as it did when the carting about of hefty accumulators was the order of the day. Still, who can say what our valve manufacturers, the most progressive in the world, will be offering us next?

### Metal Filament versus Carbon Filament

CONTINUING the subject of cold light, it is generally accepted that the fire-fly and the glow-worm share the honours of giving the most efficient light of this

class. Their light is given by chemical reactions, and is of such a nature that it can all be seen by the range of the human eye, meaning that there are practically no rays toward the infra-red end of the scale which are more felt than seen. The metal-filament lamp is much more efficient than the old carbon-filament prototype, and there is also a rather interesting distinction concerning the two lamps that might be of interest to radio men. The metal filament increases in resistance as the temperature increases, whereas the reverse is the case with a carbon filament. The result of this is that the metal-filament lamp is less affected by variations in voltage, whereas the carbon lamp is very much affected. When the voltage in a metal filament rises the temperature does so accordingly. At the same time, the resistance also rises, which in turn prevents any considerable rise in current, so that the balance of current and temperature is maintained at a fairly even level. The resistance of a carbon lamp is halved when the filament is incandescent.

### "Micro-ray" Transmissions

AN interesting installation is shortly to be erected at Lympe for cross-channel communication with the French air authorities, and even those of you who are used to working on short waves will be surprised at the small wavelengths used, while at the same time you will be able to appreciate the difficulties involved. The apparatus is known as the "Micro-ray," and communication will be carried out on a wavelength of 15 cm. or 0.15 metres. The transmitting and receiving aerials will be less than one inch in length, and the "micro-rays" which are generated in a "micro-radion" tube have a frequency of more than 2,000,000,000 per second. The rays are fed from the tube to the transmitting aerial, and concentrated by a series of mirrors into a fine pencil of rays, which are finally thrown into space by a circular reflector of about 10 feet in diameter. A similar station equipped with identical apparatus will be installed at the French Air Ministry's aerodrome at St. Inglevert. The cross-channel service will be used to announce the departure and arrival of aircraft not fitted with wireless, and the stations will be working in the New Year. We don't suppose you will hear them!

### 'Ware Mirrors

THE use of mirrors to deflect wireless waves would thus seem to be full of possibilities, but have you noticed that very poor results with portable receivers can often be traced to the effect of mirrors in the room? This was brought to our notice some time ago where a portable set was being used on a sideboard which had a large centre mirror. When the set was placed in front of this mirror the results were poor indeed, an improvement being noticeable as soon as the set was moved away from it. The portable, of course, had a frame aerial in the lid, and this was parallel to the mirror, which was acting as a large metal screen. No wonder the results were poor!

Get the  
Best Diary  
The  
BOOKLOVER'S  
DIARY  
Leather 2/6 Cloth 1/-

Easily the best diary for everyone whether interested in literature or not.

Obtainable at all Newsagents and Bookstalls, or by post 2d. extra from George Newnes, Ltd., 8-11, Southampton Street, Strand, London, W.C.2.



**Buzzer Wavemeter**

**A** WAVEMETER, that is an instrument for determining wavelengths, which employs a buzzer in order to produce the necessary radiations. The wavemeter acts as a miniature transmitting station and can be set to radiate on known wavelengths.

Suppose, for instance, you have a receiving set and you wish to know to what position you must set the tuning dial to get a station which is supposed to be transmitting on, say, 400 metres. What you do is to set the buzzer wavemeter to radiate on 400 metres and place it near your set. You then tune your set until you can hear in the speaker or 'phones the buzzing note given out by the wavemeter. The position of the tuning dial which gives the loudest signal is the setting desired. At that point your set is tuned to 400 metres and the exact position of the dial can be noted and marked. In the same way other wavelengths may be arrived at and, if necessary, your set can be completely calibrated by setting the wavemeter to radiate on a series of different wavelengths. (See also "Buzzer" and "Wavemeter.")

**"C" Battery**

A term used in America and some other countries to denote the grid bias battery. Under this system the low-tension battery, or accumulator, is called the "A" battery and the high-tension (H.T.) battery is designated the "B" battery.

**Capacity**

(of an accumulator or storage battery) is the amount of electricity it will deliver when fully charged. This is measured in

**THE BEGINNER'S ABC OF WIRELESS TERMS**

ampere-hours. (See "Ampere-Hour.") For instance, if the capacity of an accumulator is said to be 20 ampere hours (amp. hrs.) it means that, theoretically, it will deliver current at the rate of one amp. for twenty hours—or its equivalent, say, half an amp. for forty hours or two amps. for ten hours. In practice, however, it will be found that the capacity of an accumulator depends to some extent on how quickly it is discharged. The quicker the current is taken from it the less time it will actually last. This means that an accumulator which would give, perhaps, half an amp. for forty hours, would most likely not last for ten hours if discharged at the rate of two amps. all the time.

Sometimes the capacity of an accumulator is stated as an *intermittent* rate. This is rather mis-

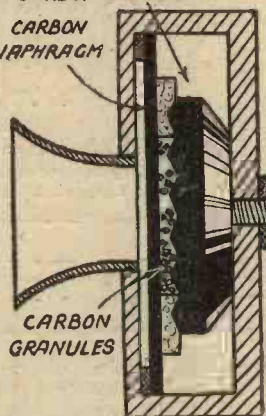

Fig. 2.—A carbon microphone—showing the arrangement of carbon granules and block.

leading to the uninitiated, but means that the *actual* capacity is half of this figure. Thus, if you see "20 amp. hrs. intermittent" or "20 amp. hrs. int." printed on an accumulator, you will know that the accumulator will actually give only 10 ampere-hours of electricity.

**Capacity**

(of a condenser)—is its ability to store up electricity. It is measured by the amount of electricity which will cause a difference of potential of one volt between the plates of the condenser. A condenser which required one *coulomb* of electricity put into it to cause a difference of one volt in the po-

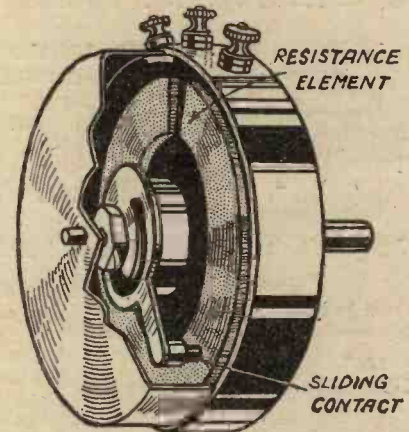

Fig. 3.—One type of potentiometer or variable resistance.

tential of the plates would be said to have a capacity of one *farad*. This unit is too large for practical purposes, so we more often speak of *microfarads* (*mfd.*). A microfarad is a millionth part of a farad.

**Carbon**

The form of carbon that is met with in electrical and wireless apparatus is known as *gas carbon*, and is a by-product of the gas industry. It is a hard, black substance, and although non-metallic is a comparatively good conductor of electricity. A small stick of carbon about two inches long is used as the positive element in each of the cells of dry batteries as used for high tension and grid bias purposes. (See Fig. 1.)

Carbon is also used in the construction of the carbon microphone (See *Microphone*). This usually consists of a thin carbon disc or diaphragm and a carbon plate. These are separated by a small gap which is loosely filled with small pieces or *granules* of carbon. (See Fig. 2.)

Another form of carbon is *graphite*, and sometimes compounds of graphite are used as resistance elements in both fixed and variable resistances. Fig. 3 shows one form of variable resistance in which the element is in the shape of a circular disc. A revolving arm makes a rubbing contact with the element.

**Carrier Wave**

The wireless waves or high-frequency oscillations given out by a telephony transmitter such as a broadcasting station. The oscillations are not of uniform intensity, but vary according to the speech or music that is being transmitted.

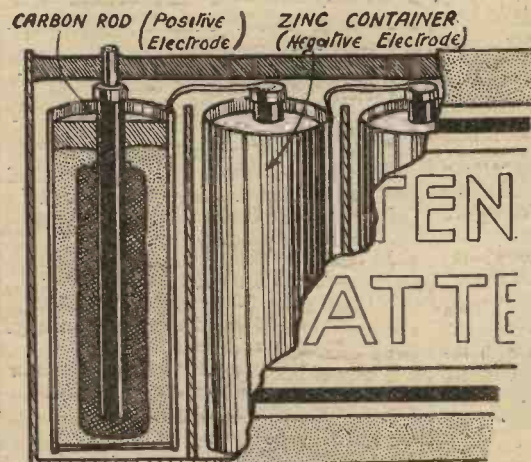

Fig. 1.—The internal construction of a dry battery of the high-tension type.

The idea behind the term "carrier wave" is that the speech, etc., is "carried" by these oscillations from the transmitter to the receiver.

**Cascade**

Wireless and electrical apparatus such as valves, amplifiers, etc., are said to be connected in cascade when the output of the first is joined to the input of the second, the output of the second to the input of the third, and so on.

**Cathode**

A term used to denote the negative pole of a piece of apparatus. It is more particularly used in reference to the negative electrode of valves, X-ray tubes, vapour lamps, etc. It is the element

current. This is why it is used in mains valves. If a battery type of valve were used in a mains set the rise and fall in the alternating current used to heat the filament would cause a corresponding rise and fall in its temperature, and thus cause fluctuations in the emission of the electrons, resulting in violent mains hum. The indirectly-heated cathode, by reason of its insensitiveness to rapid changes of temperature, gives out a constant stream of electrons and thus overcomes this difficulty. Fig. 5 is a sectioned view of a mains valve showing the indirectly-heated cathode.

**Cat's Whisker**

The fine wire used in some crystal detectors to make contact with the crystal. It is usually made in a spiral form like a small spring as in Fig. 6. The point of the cat's whisker is moved over the

surface of the crystal until a sensitive spot is discovered. Best results are usually obtained when the point rests on the crystal with the very lightest pressure. Various metals have been used for cat's whiskers, including gold and silver, but very little advantage seems to accrue from the use of precious metals. A piece of fine copper wire gives quite satisfactory results.

**Cell**

A single unit in a battery is called a cell. In the case of ordinary batteries which cannot be re-charged it is called a primary cell, whereas a single 2-volt accumulator or storage battery is known as a secondary cell. The term "battery" is often misapplied to a cell. A battery is a collection of cells and a single 2-volt accumulator is a cell and not a battery. A car battery, on the other hand, really is a battery, as it contains several secondary cells joined together, so also is an H.T. battery, since it is made up of a number of primary cells.

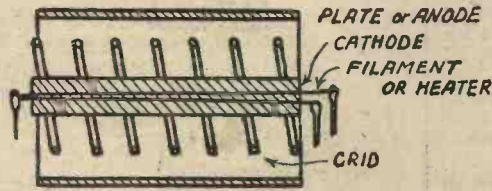

Fig. 5.—The cathode of an indirectly-heated valve.

from which the negative particles of electricity or electrons are given off.

In a battery-heated valve the filament is the cathode, as it is from this that the electrons emanate. (See Fig. 4.)

In a mains valve, that is one made for use in an all-mains set, the filament is not the cathode, but is merely used to heat an element which surrounds it. This element is called an indirectly-heated cathode, and it is from this that the electrons are given off. Being of greater mass than the filament it has the advantage that it remains at an even temperature in spite of fluctuations in the filament

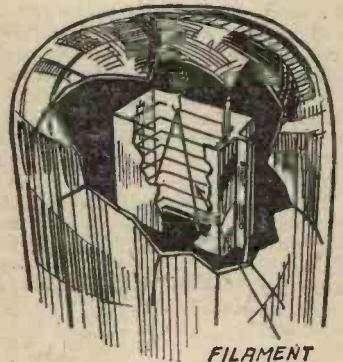

Fig. 4.—The filament (or cathode) of an ordinary battery-heated valve.

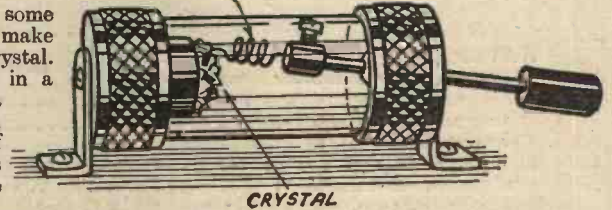

Fig. 6.—A standard form of crystal detector.

usually consists of two conducting elements, such as two dissimilar metals or a metal and a stick of carbon. These are separated by a fluid or paste. When the two elements are joined by a wire chemical action takes place in the cell and causes an electric current to flow along the wire. A section of a typical cell is shown in Fig. 1.

A cell whether primary or secondary usually consists of two conducting elements, such as two dissimilar metals or a metal and a stick of carbon. These are separated by a fluid or paste. When the two elements are joined by a wire chemical action takes place in the cell and causes an electric current to flow along the wire. A section of a typical cell is shown in Fig. 1.

**THE SOLO KNOB THREE**

Owing to pressure on our space in the Christmas number (December 10th issue) it was not found possible to publish the circuit of the Solo Knob Three. This is now given for the benefit of those readers who prefer to wire up a receiver

from a theoretical diagram. It should also be noted that two Belling Lee terminal mounts, and four Belling Lee terminals, type B, marked Aerial, Earth, L.S.— and L.S.+, are required in addition to the list of components given

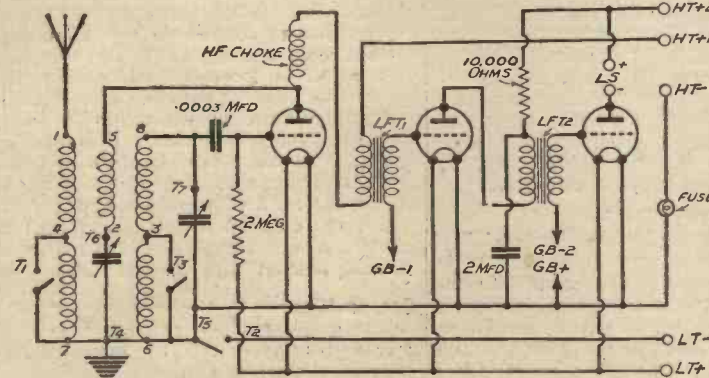

The circuit of the Solo Knob. The construction of this receiver was fully described in the Christmas number, dated December 10th.

in the Christmas number. For the benefit of those who are constructing this receiver the complete list of components is repeated.

- 1 Lissen Ganged Condenser Tuning Control Unit.
- 1 Telsen Matched Screened Coil.
- 1 Ready Radio 3-1 Transformer.
- 1 Telsen Acc 5-1 Transformer.
- 1 T.C.C. .0002 mfd. Fixed Condenser, Type S.
- 1 T.C.C. 2 mfd. Fixed Condenser, Type 50.
- 1 Graham Farish Horizontal Grid Leak Holder.
- 1 Graham Farish 2 megohm Grid Leak.
- 1 Bulgin Baseboard Fuse Holder and Fuse.
- 1 Bulgin 10,000 ohms Spaghetti Resistance.
- 1 Graham Farish Snap H.F. Choke.
- 3 W.B. 4-pin Valveholders.
- 1 Ebonite Panel (Permcot), 12in. by 7in.
- 2 Belling Lee Terminal Mounts.
- 4 Belling Lee Terminals, Type B, marked Earth, Aerial, L.S.— and L.S.+.
- 1 Coil Glazite Connecting Wire.
- 1 Cossor 210 Det. Valve.
- 1 Cossor 210 L.F. Valve.
- 1 Cossor 215 P. Valve.
- 1 Belling Lee 5-way Battery Cord.
- 1 Ediswan 105-volt Super H.T. Battery.
- 1 Ediswan 9-volt Grid Battery.
- 1 Ediswan 2-volt 40 amp. Accumulator
- 1 Ormond Loud-Speaker, Type 452.
- 1 Osborn Cabinet, Type 178.
- 1 Tin of Filt.
- 1 Wooden Baseboard, 12in. by 10in.
- Screws, Flex, 3 Wander Plugs marked G.B.+, G.B.1 and G.B.2.

# OUR ARTIST SUCCUMBS TO AMERICAN RADIO INFLUENCE

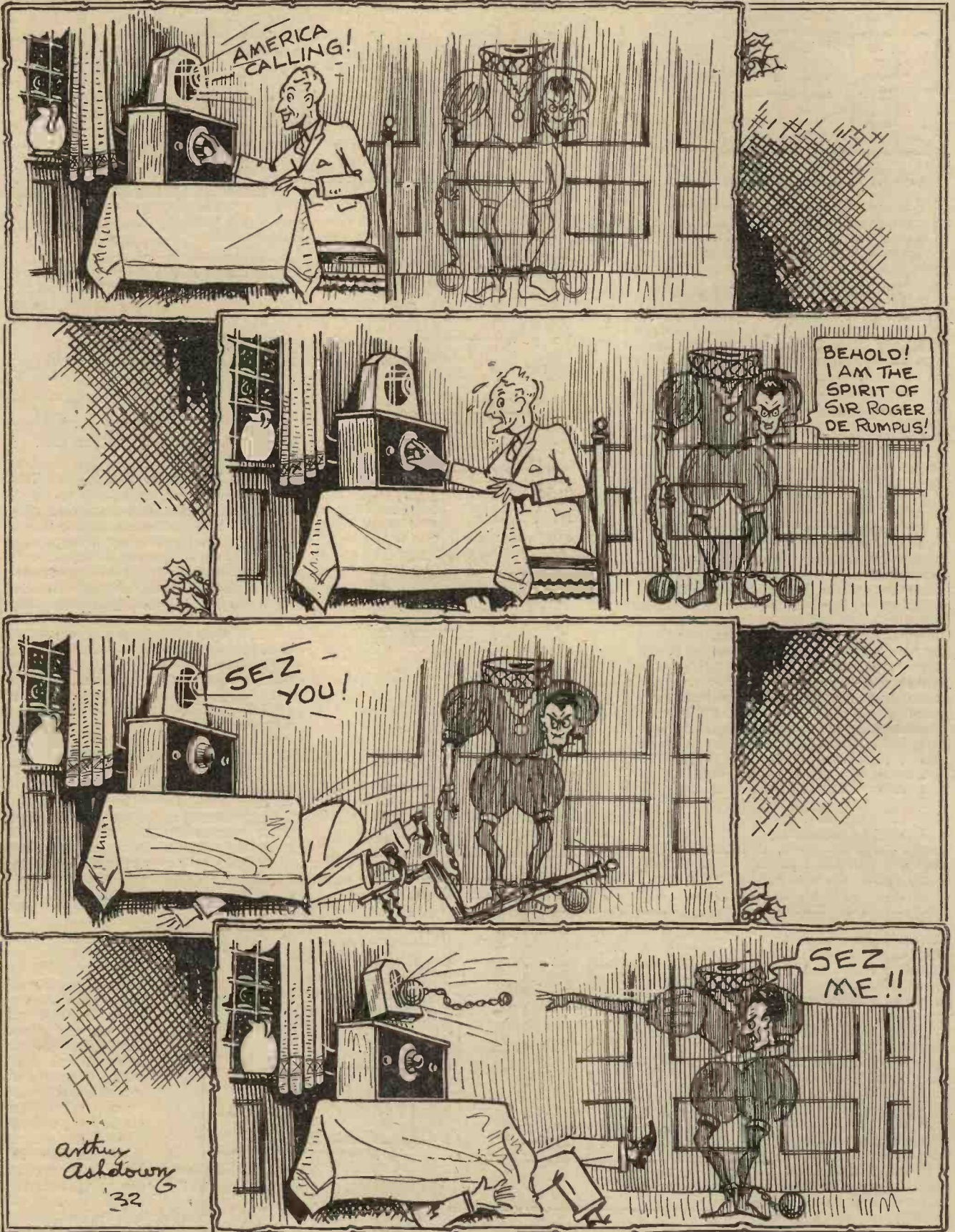

# ALL ABOUT GRID BIAS

Valuable and Complete Information about an Important Subject

By G. V. COLLE

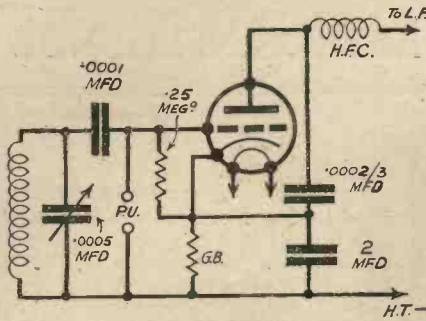

Fig. 2.—Typical detector arrangement.

It is inevitable when one is engaged for many years in the technical branch of an industry such as radio, to acquire a first-hand practical knowledge of constructional "snags." It is equally certain one also discovers where theory and practice differ, particularly after building no less than one thousand sets of various designs ranging from crystal to multi-stage super-hets. Such is the writer's experience, and should anyone consider this savours of unnecessary pride, it can only be excused on the ground that it lends support to the recommendations made hereunder on grid-bias schemes.

During the past two years in particular, immense strides have been made by manufacturers of fixed condensers and resistances to produce components suitable for the indirectly-heated mains valves, and whereas formerly these parts were universal, large in bulk, and expensive, they can now be purchased in specialized forms. Take, for instance, the fixed condenser connected across the grid-biasing resistance in the cathode lead of an indirectly-heated mains valve, in which it acts as a reservoir capacity. Until of late, this condenser was of quite small capacity, ranging, say, from .5 to 2 mfd., tested to 200 volts or so working voltage. An examination of a valve list will show such valves rarely, if ever, require more than 40 volts negative grid bias, and consequently one had to pay for a condenser literally too good for the purpose. Nowadays, dry electrolytic condensers of lower working voltage rating are procurable at cheaper or equal prices and with capacities ranging from 10 to 100 mfd.

### Grid-biasing Resistance

The extra smoothing afforded by the larger capacity (and, incidentally, considerably smaller bulk of the condenser) is apparent in the lower residual "hum" level normally achieved, due to the larger reservoir action. Turning to the grid-biasing resistance itself, this was formerly quite a clumsy affair, consisting of a round rheostat winding arrangement, or a clumsy former wound with many turns of wire, out of proportion to the current to be carried.

Here again rapid strides have been made in reducing the bulk of the component, and classifying the current dissipation in watts or milliamperes. Among the types procurable there are synthetic graphite resistances in vacuum, compressed

solid graphite or leaky compounds and wire-wound asbestos cord elements wound around small grooved porcelain or heat-resisting formers. Each of these resis-

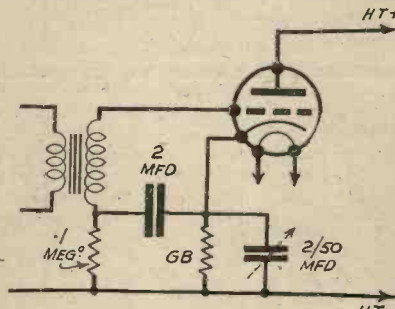

Fig. 3.—Intermediate L.F. stage.

tances is a specialized component, inasmuch as the maker suggests it be used for certain purposes and fills "gaps" with other types.

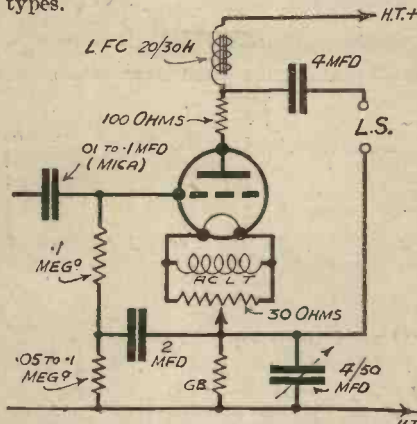

Fig. 4.—Modern arrangement of the output stage, employing directly-heated mains valves.

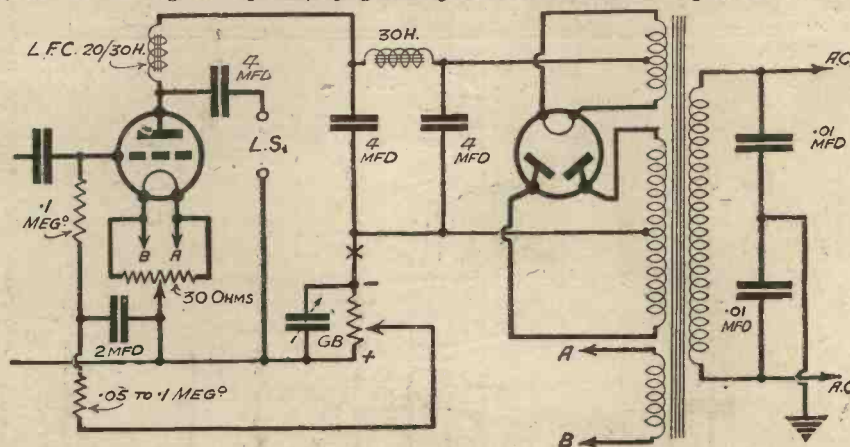

Fig. 5.—Arrangement where the G.B. resistance for the last valve acts as a H.T. voltage dropper.

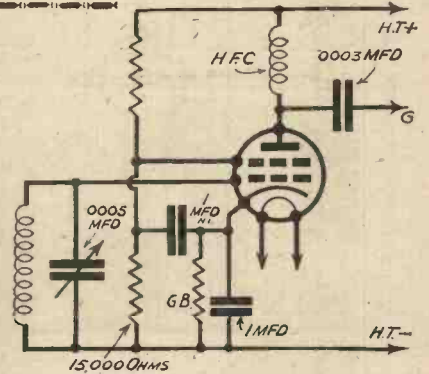

Fig. 1.—Simple arrangement for variable grid bias.

Taking practical examples, a wire-wound affair would undoubtedly be recommended for the voltage-dropping resistance in the cathode lead of an L.F. or power valve, where the anode current (and consequently the current in the cathode lead) is considerable. For a mains H.F. S.G. valve of standard type a resistance other than a wire-wound affair would be suitable, always provided it is rated to carry the current consumed by the valve, plus a safety margin of, say, 25 per cent.

### Grid-bias Voltage for Variable-mu Valves

The variable-mu screen-grid valve, which is of modern design, necessitates quite a different kind of resistance for the grid bias, since it operates by changes of grid-bias voltage, and consequently calls for a variable resistance. This latter component is, of course, as old as radio itself, but owing to the high values of anode current produced at low grid-bias voltage the resistance element must of necessity be wire-wound, and, furthermore, of a substantial gauge of "Nichrome" wire. To produce equal volume changes for equal movements of the control knob, and especially with 1932-3 variable-mu valves, the wire resistance track must have practically a logarithmic action, achieved by tapering the resistance element.

It is necessary to qualify the latter statement by adding that the taper element is only necessary where the grid-bias voltage alone is varied (see Fig. 1). Certain other volume-control schemes include a reduction of aerial input with an increase of grid-bias voltage as in Fig. 7, and here the resistance should be of equal value for equal movements of the knob; in other

words, the resistance element can be of a standard type, subject to current-carrying conditions. Referring more fully to the circuits reproduced here, Fig. 2 is a typical detector arrangement for "pick-up" or radio reproduction. An external volume control is a necessity with the "pick-up," otherwise overloading will occur. The G.B. reservoir condenser can be of low voltage type, rated according to the valve-maker's suggestion, and of a moderate capacity as marked, or up to 10 mfd.

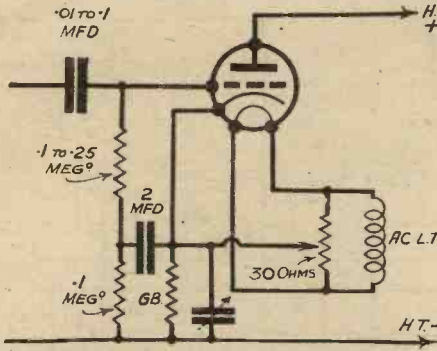

Fig. 6.—Useful arrangement employing five-socket valve holder, enabling direct or indirect heated A.C. valves to be used without wiring modification.

**Decoupling**

Fig. 3 illustrates an intermediate L.F. stage (or a low-powered, indirectly-heated output valve). Particularly is the attention of the reader directed to the decoupling device in the grid circuit, it having been assumed there are other L.F. circuits, or considerable H.F. amplification before this stage. Strange as it may seem, set designers pay little or no attention to devices of this nature, as, in the writer's experience, a little arrangement of this nature often cures a tendency to "motor-boating." Increases in the H.T. decoupling arrangement are usually tried, at increased cost and often at the expense of H.T. voltage, which is reduced, due to the inclusion of a higher value resistance in the H.T. positive lead. For one L.F. stage, grid decoupling is usually redundant.

An example of a modern output L.F. stage, employing a directly-heated slow heating mains valve, is given in Fig. 4, and full use is made of an electrolytic G.B. condenser. Since these condensers have polarity owing to their internal construction, it is very important their outer metal cases (negative) are joined to the common H.T. negative lead. On a metal chassis the round canister type are inverted and fixed through a hole in the metal and locked with a single nut. The circuit is applicable to those modern and

highly-efficient valves, the Mazda PP5-400 and Marconi and Osram PX25.

**An Unusual Circuit**

A somewhat unusual circuit is shown in Fig. 5, the G.B. resistance for the last valve also acting as a voltage-dropping H.T. resistance, it being assumed the H.T. voltage output is in excess of what is required by the set. The value of the device lies in the fact that constructors can make use of A.C. transformers or H.T. supplies of high power with small sets. If the output of the H.T. unit is some 100 to 150 volts in excess of requirements, it is possible to include the field winding of a M.E. loud-speaker at the point X and use a series resistance

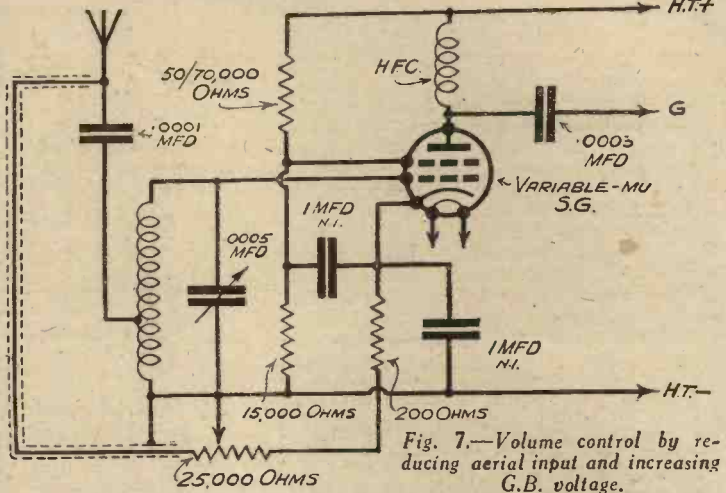

Fig. 7.—Volume control by reducing aerial input and increasing G.B. voltage.

holder to utilize either a direct or indirectly-heated A.C. valve without wiring modifications. Of course, the G.B. resistance must be replaceable if the requirements of the valves used are different.

Fig. 7 has already been discussed, and Fig. 8 is an elaboration of the former, two variable-mu S.G. stages being employed.

The volume control should be a resistance with a logarithmic winding as mentioned previously.

**Precautions When**

Using a Pick-up  
For super-het. enthusiasts and users of sets having two S.G. stages, the circuits Figs. 9 and 9A will prove of interest, being detector (2nd detector for super-hets.) circuits utilizing S.G. standard valves. Both arrangements are practical ones, having been thoroughly tested. Provision is made for "pick-up" with external volume control. In Fig. 9A, and using the pick-up, and

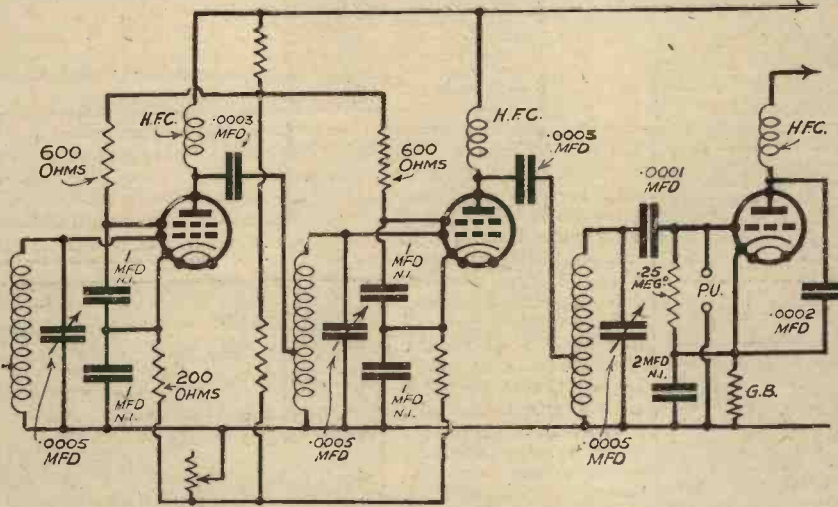
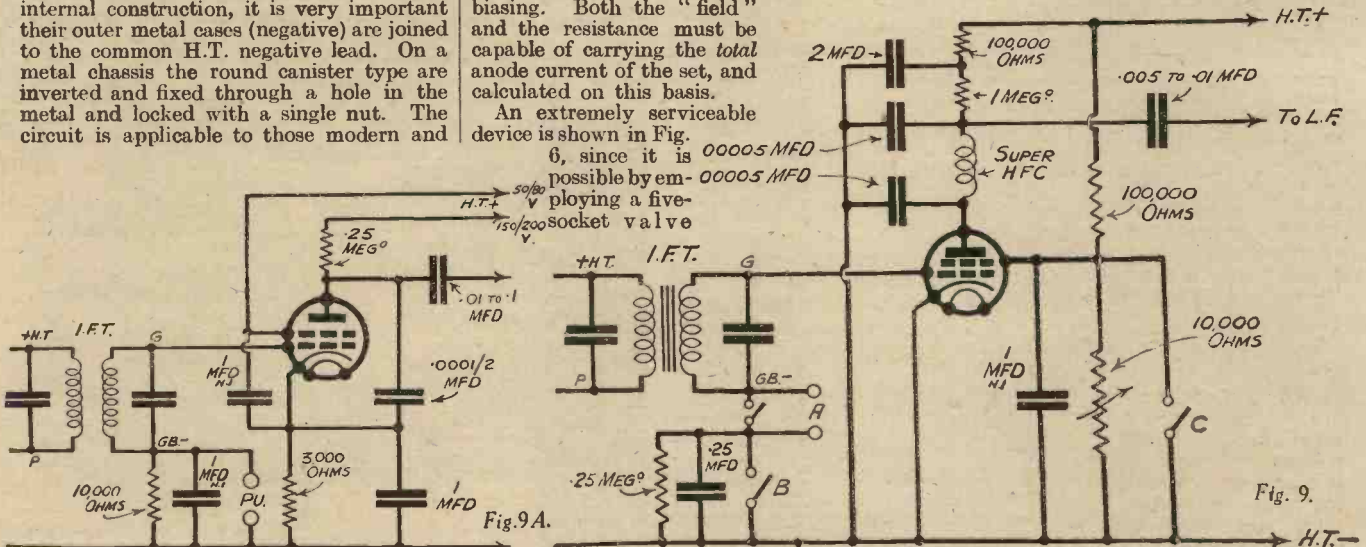

Fig. 8.—An elaboration of Fig. 7, employing two variable-mu stages.

for G.B. strictly to the value for correct biasing. Both the "field" and the resistance must be capable of carrying the total anode current of the set, and calculated on this basis.

An extremely serviceable device is shown in Fig. 6, since it is possible by employing a five-socket valve



Figs. 9 and 9A.—Arrangement for super-hets. and sets employing two S.G. stages.

"C" open. The reverse order is the case for radio reception. With certain valves switch "C" can be omitted, but in any case it is important that all radio controls are "de-sensitized" when using the "pick-up."

To avoid misunderstandings, it can be explained at this stage Figs. 1, 2, 3, 7, 8, 9 and 9A are applicable to D.C. indirectly-heated valves as well as A.C., although in Figs. 2, 8, 9 and 9A precautions are necessary in order to guard against shocks with the "pick-up," as sometimes the negative mains lead is above earth potential to the full extent of the mains voltage. In such instances the use of a "pick-up" transformer, ratio 1 to 1, or fixed condensers in each lead is called for. On A.C. supplies precautions of this nature are unnecessary.

Automatic grid bias is only beginning to be realized as a practical possibility on portable battery sets, and Fig. 10 is a typical example of one possible arrangement. The basic circuit is one of four valves as shown, and grid bias is derived from a voltage drop depending on the total anode current in the H.T. negative lead. A useful table accompanies the circuit, and should prove of value to prospective constructors.

This table will enable resistances to be chosen for practically any type of portable receiver, and covers the complete range of voltages required.

The actual components may be of any type, provided they are chosen to carry the current without heating, and are at the same time small and light in weight.

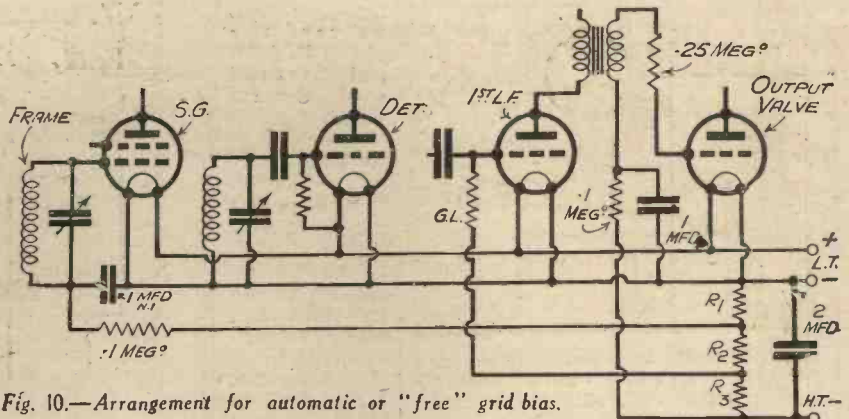

Fig. 10.—Arrangement for automatic or "free" grid bias.

G.B. RESISTANCES FOR PORTABLE BATTERY SET.

Total Anode Current M/A	Total Approx. R1+R2+R3	R.1. G.B. H.F. Valve		R2 (+R1) G.B. 1st L.F.			R3 (+R1+R2) G.B. 2nd L.F.			
		.9v.	1.5v.	1.5v.	3v.	4.5v.	6v.	7.5v.	9v.	12v.
* 7	1,800	130 (150)	215 (200)	215 (200)	430 (400)	643 (600)	857 (750)	1,070 (1,000)	1,290 (1,000)	1,714 (1,500)
* 8	1,125	112 (100)	188 (200)	188 (200)	375 (400)	562 (500)	750 (750)	937 (1,000)	1,125 (1,000)	1,500 (1,500)
* 9	1,000	100 (100)	166 (150)	166 (150)	333 (300)	500 (500)	666 (600)	833 (750)	1,000 (1,000)	1,333 (1,000)
* 10	900	90 (100)	150 (150)	150 (150)	300 (300)	450 (400)	600 (600)	750 (750)	900 (1,000)	1,200 (1,000)

\* Nearest commercial resistance values. Intermediate values obtainable by parallel or series connections of two or more resistances. Note.—The value of R2 can be found by deducting the value of R1 chosen previously. R3 is then chosen and the values of R1 plus the final value of R2 (R2—R1) deducted.

TAMING THE ETHER GIANTS

By A. J. WOOD

THE gradual increase in the number of broadcasting stations adopting high power, whilst satisfactory in some respects, presents for many listeners a problem that is not easy of solution. They find these stations butting in when they are not wanted, and no amount of dial adjustment will altogether eliminate them. It is particularly disconcerting when the interference upsets the local programme you are listening to, as is often the case. If these listeners are using an outdoor aerial and their sets are not very selective, they stand very little chance of improving matters short of a radical alteration of their sets, and this is not always practicable, often for reasons of economy. Nevertheless, if they are willing to compromise in the cause of comfortable listening, they have a remedy at hand which is both easy and economical to apply. Let them try the simple expedient of a short indoor aerial, not one that goes somewhere upstairs, or all round a picture rail, but simply a short length of insulated stranded wire (about 8 feet or so will do) suspended from a hook on the picture rail, and just long enough to reach down to the aerial terminal of the set.

Speaking from my own experience, I was much surprised when I first tried it out as an experiment, and found what could be done by such simple means. I really tried it in the first instance to cut down the great strength (using an outside aerial) of the Moorside Edge transmitters. Even on so short an aerial as this they are still very strong, and need no reaction. Much to my surprise, however, I soon found out that its use was not confined to receiving

the local in comfort, but, with the aid of reaction, was eminently satisfactory in also bringing in a number of the more powerful foreigners at quite good strength, clear of interference. Leipzig, Stuttgart, Strasbourg, Poste Parisien, Breslau, Heilsberg, and Trieste were all received at good loud-speaker strength without pushing reaction to the limit on a simple three-valve set (o-v-2), so that a set using a stage of H.F. ought to do very well indeed on such a short aerial as above described. I may add that other stations were also heard, but I have only mentioned those that were really good enough for loud-speaker reception.

As more foreign stations will shortly be increasing their strength, and still further complicate matters, this short indoor aerial should greatly assist those whose sets are a bit too powerful for a decent measure of station separation on strong signals. Actually the position is this: If foreign stations will not reduce their power, then those listeners who are troubled by them can easily adjust themselves to the new conditions by taking steps to minimise their interference by the simple means suggested. This

will give just that necessary degree of "selectivity" to suit the circumstances. The outdoor aerial can be left for special occasions, if desired.

MUSIC FOR ARCTIC EXPLORERS.



The expedition which recently left U.S.A. to explore the Arctic regions under Lieut.-Commander Richard Byrd, will be kept entertained by music received on the powerful wireless equipment they carry



*a Gift Suggestion*  
**Amazing Selectivity**  
**— ALL stations clearly**  
**and without overlapping**

**AND NO  
 ATMOSPHERICS**



Improve your radio beyond all recognition! Hear all stations—even those you have never heard before—clearly and distinctly... with whatever degree of volume you please... without distortion of any kind... without annoying static noises. You can with a Cop. It is

**7 ACCESSORIES IN ONE**  
 —all combined in a well-made, super efficient aerial lead-in and automatic cut-out which—even during the worst of storms—will enable you and yours to listen in safety (backed by a £100 FREE Insurance Policy against damage by lightning). What gift would be more appreciated by your radio friends. A Cop is just the thing you need, too! Get one TO-DAY—from your local Radio Dealer, or post free, direct from the makers:

**PRESSLAND  
 AERIAL CONTROL**

CLIFFORD R. PRESSLAND  
 (SALES) LTD.,  
 84, Eden Street,  
 KINGSTON-ON-THAMES.

PRICE  
**2/6**

**COP**

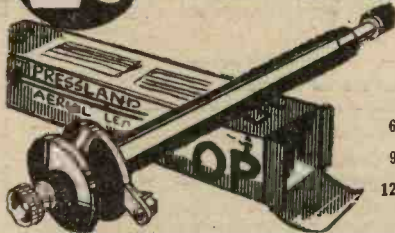

Prices:  
 6 in. 2/6  
 9 in. 3/-  
 12 in. 3/6

**£100  
 FREE  
 INSURANCE  
 AGAINST  
 LIGHTNING**

*Scientific*

**PIX INVISIBLE AERIAL**

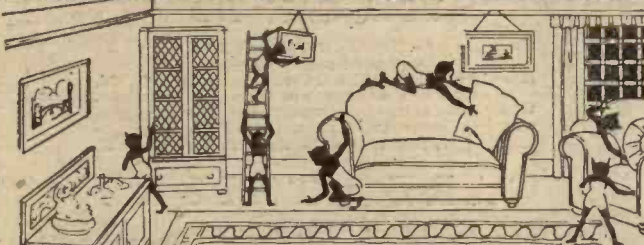

**AS GOOD AS AN  
 OUTSIDE AERIAL—  
 YET INVISIBLE!**

Just imagine listening in on an Aerial actually in the room, yet you cannot see it! Like Radio itself—invisible. Getting the same reception as on an outside Aerial, without unsightly poles, lead-in tubes, insulators, loose wires. Every modern set needs an Invisible Aerial.

**NO WIRES.** No danger from lightning, reduces Static interferences and increases selectivity! **WHAT AN AERIAL!** Just a 30ft. roll of narrow adhesive tape which you press around the room below the picture rail, wainscoting, carpet, or up the staircase—in fact, anywhere. Pull the end and it's down and leaves no mark.

**DEAL FOR USE IN FLATS.**

Being in the form of a narrow self-adhesive strip 30ft. in length, can be fixed anywhere in a moment without tools.

THE BRITISH PIX  
 COMPANY, LTD.  
 (Dept. 316),  
 118-28, Southwark Street,  
 London, S.E.1.

**EVEN  
 THE  
 PIXIES  
 CANT  
 FIND IT**  
**2/-**  
 POST FREE  
 Or from your Dealer.  
 Double Length, 3/6



**P/X INVISIBLE AERIAL**  
**AS GOOD AS AN OUTSIDE AERIAL!**

Higher ampere-hour efficiency means  
**QUICKER CHARGING**  
**SLOWER DISCHARGING**  
**LONGER LIFE**



Type E.L.S.7. 60 a/h capacity. Price **12/6**



Type E.L.M.4. 45 a/h capacity. Price **8/-**



Type E.L.9. 80 a/h capacity. Price **12/3**

“Balanced Capacity,” the new principle utilised in Ediswan Extra-life Accumulators, means higher ampere-hour efficiency. The special design of the positive and negative plates ensures complete electrical “balance” and reduces the possibility of “shedding” to an absolute minimum. In addition to their high electrical efficiency, these accumulators embody many mechanical refinements—British-made clear glass containers, moulded ebonite lids, screwed vents, non-corrodible and non-interchangeable connectors and metal carrier which fits neatly round the container.

**EDISWAN**  
**EXTRA-LIFE**  
**ACCUMULATORS**



THE EDISON SWAN ELECTRIC CO. LTD.  
 155 CHARING CROSS ROAD, LONDON, W.C.2

B.208

LET YOUR SET  
GAIN—

**RENOWN**  
The **SPEAKER** with  
the **PERFECT ACCENT**

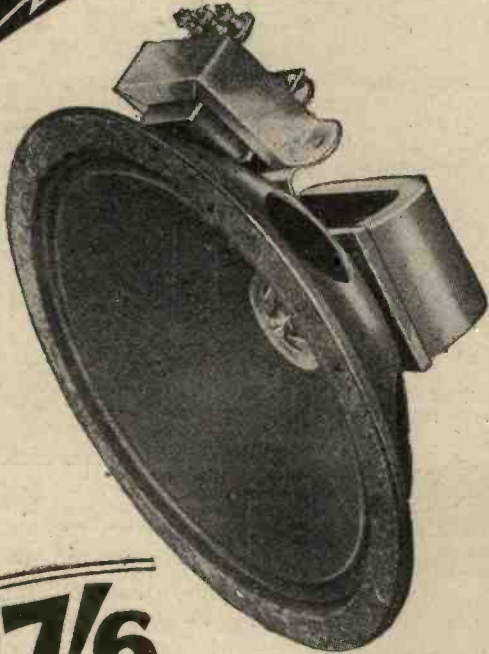

**27/6**  
**CHASSIS**

Also Complete in Real  
WALNUT CABINET 42/-

**READ THIS  
SPECIFICATION:**

Incorporating a new formula in Magnet design, concentrating the flux where it is required. This is achieved by employing high percentage Cobalt Pole pieces—the body of the Magnet being made from special metal. Specially treated "Veratone" Cone. Heavy gauge steel chassis. Overall diameter 8½ in. Complete with Multi-ratio Transformer for use with any Output Valve. Highly finished glossy brown cellulose. Here you have the product of MANUFACTURERS who have SPECIALISED for years on Loud Speakers.

Never-ending research and the facilities to produce Loud Speakers of outstanding merit in all types have now resulted in something to give you such QUALITY in workmanship and performance as to amaze you. Ask to hear the "RENOWN" at your Dealer's.

**A FULL-SIZE SPEAKER—NOT A MIDGET**

Fully illustrated List of all models (including the now famous "Dreadnought" at 39/6) sent post free on request.

**GOODMANS**

69, St. JOHN ST., LONDON, E.C.1. Clerkenwell 3838-9.

**NEW**

**GAMES AND  
TRICKS FOR  
CHRISTMAS!**

New games are always enjoyed. New tricks are always appreciated. Here are a few books explaining many really new games and tricks with which you can give your friends a merry Christmas.

**CARD GAMES**

And How to Play Them.

By PETER ALSTON.

Stiff boards. Price 2s. net, post free 2s. 3d.

A Guide to all the popular games played to-day. Whist—Solo, Auction and Progressive—Bridge, including Royal Auction and Contract—Baccarat—Bezique—Cribbage—"Nap"—Poker—Piquet—Vingt-et-Un—Patience Games, etc., etc.

**BROADCAST  
CONJURING TRICKS**

By CYRIL SHIELDS,

The well-known wireless magician.

Price 2s, post free 2s. 4d.

Mr. Shields dedicates his books to his many friends and the hundreds of children who wrote to him when he was giving lessons in Simple Conjuring Tricks during the children's hour.

**100 MORE TRICKS  
YOU CAN DO**

By HOWARD THURSTON,

America's Leading Conjuror.

Bound in Cloth, Price 2s. net, post free 2s. 3d.

Any trick is easy when you know how it's done. With the aid of this book you can mystify your friends with Card Tricks, Coin Tricks, Match Tricks, Handkerchief Tricks, etc., as easily as a professional conjurer.

**CARD TRICKS**

By L. WIDDOP.

Stiff Boards. Price 2s. net, post free 2s. 3d.

A Volume which will give the Amateur or Semi-Professional, who does not wish to spend a great deal of time in practice, material for entertaining performances. Card Tricks presented in new forms and with up-to-date patter.

**THE BEST TRICKS  
AND HOW TO DO THEM**

By DAVID DEVANT,

The Well-known Conjuror.

Price 2s. net, post free 2s. 4d.

The contents include Coin Tricks, Tricks with Balls; Card Tricks, Feats of Memory, etc., etc.

**MATCH STICK MAGIC**

By WILL BLYTH, M.I.M.C.

With a Foreword by David Devant.

Illustrated by 160 Diagrams.

Stiff Boards. Price 2s. net, post free 2s. 3d.

Being a Collection of Entertaining, Amusing and Instructive Puzzles, Games, Scientific and Constructional Experiments, Conjuring Tricks, etc., to perform which only a few matchsticks are required.

May be had of all booksellers or for Post Free prices direct from the Book Publisher, PEARSON'S Book Dept., 18, Henrietta Street, London, W.C.2. Full list on application.

# RADIO RAMBLINGS

## Cutting Out the S.G. Valve

FOR reception of the local stations an S.G. valve is often a disadvantage because it tends to cause both detector and low frequency valves to become overloaded. There are various ways of cutting out the S.G. stage for local reception and a number of these have previously been described in PRACTICAL WIRELESS. In general the methods consist of transferring the aerial from the aerial coil to the second tuned circuit. This is very simple of accomplishment and is sometimes fairly satisfactory, but has the serious disadvantage of causing a tremendous drop in selectivity due to the elimination of one tuned circuit. It is possible, however, to cut out the S.G. valve without any loss of selectivity whatever. By connecting a .0001 mfd. pre-set condenser between the anode of the S.G. valve and the "top" of the aerial coil the two coils form a band-pass filter. An "On-Off" switch is connected in the filament lead so that an economy can be effected by cutting off the L.T. supply to the first valve. The .0001 mfd. pre-set condenser must first be adjusted to the position which gives the desired degree of selectivity, but afterwards it can be left entirely alone. This condenser could be brought into circuit by means of a switch, but the capacity of the latter would probably have a bad effect and so it is better to leave one terminal connected to the coil and connect the other to the anode of the S.G. valve, by means of a short length of flex, each time the valve is to be cut out.

## Pick-Up Improvement

MANY listeners are disappointed when first trying a pick-up on their set because they find reproduction far from satisfactory. Generally the reason can be traced to a fault in the amplifier (even though it works well enough on radio), but much can be done to improve results by connecting different condensers and resistances across the pick-up terminals. Sometimes a resistance or condenser by itself will do the trick but quite often best results are obtained by combining resistances and condensers as shown in Fig. 1. If a 10,000 ohm variable resistance is available this should be tried first; afterwards try a .001 mfd. pre-set condenser and then combine the two. A

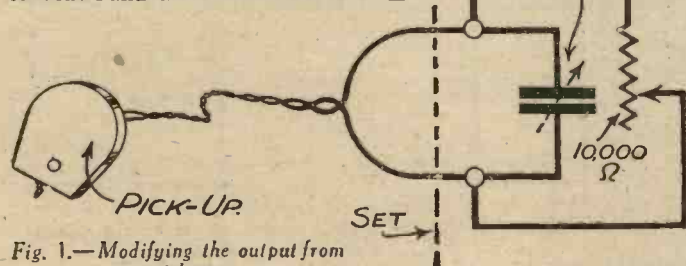

Fig. 1.—Modifying the output from a pick-up.

## JOTTINGS FROM MY NOTEBOOK.

By "DETECTOR."

little experiment on these lines will enable you to get just the tone required, and, if suitable valves are chosen, needle scratch can be greatly reduced.

## Sun-Spots

RECEPTION conditions are remarkably good this winter; in fact, in my opinion, they are quite as good as they were in 1925. The reason is attributed to presence of sun spots, which are known to have a great effect on the propagation of wireless waves. Sun-spot cycles occur about every seven or eight years, and during the sun-spot periods conditions are abnormally good. I remember that during the winter of 1924-25 I was successful in bringing in quite a number of American and Canadian medium-wave stations on a single valve set. Of course, I used phones, but by adding a "2L.F." amplifier decent loud-speaker reception was possible. At that time I did not consider it any great feat to tune in all the British and Continental broadcasting stations then in existence on a single valve set, and stations like Madrid, Ecole Supérieure, and Radio Belgique were very popular. When one considers that most of these stations then worked on a power of 1½ kilowatts or less the results appear all the more remarkable.

## Distant Reception.

BUT to return to the present season; we find loud stations all round the dials and the greatest difficulty is to eliminate the unwanted ones. Selectivity is all-important, but even if your set is not selective you need not be deprived of American reception because the number of stations working after midnight are comparatively few. I have stayed up until 2 a.m. a few nights recently and have been rewarded by the good reception of quite a number of stations from the other side of

the Atlantic. The most consistent stations have been WGY, WGZ, WBG and KDKA, but others have been picked up at intervals.

## Nearer Stations

IN regard to nearer stations I have found the Italians best of all. Trieste on 247.7 metres, not usually a very powerful station, is coming through with tremendous "punch" and with only faint fading. Rome is the same old steady signal, always reliable and always worth listening to. Turin, Genoa, Milan and Florence are not quite so loud but can be brought in with

## MEDIUM WAVE SCALE

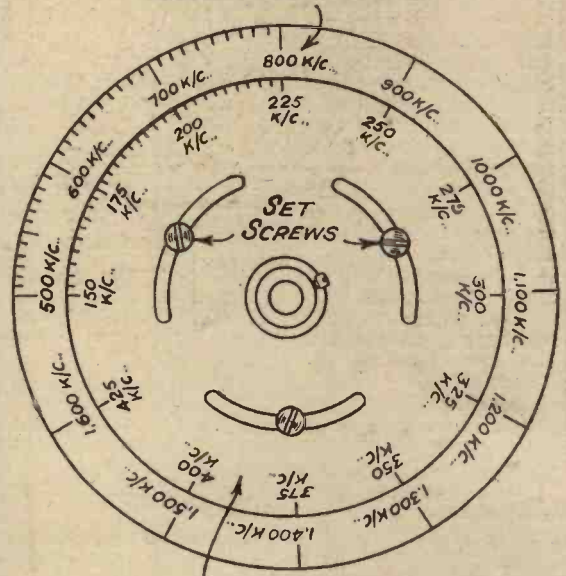

## LONG WAVE SCALE (ADJUSTABLE.)

Fig. 2.—An adjustable logging scale.

ease at any time after six o'clock or so. The Germans—Leipzig, Heilsburg, Langenberg and Koenigswusterhausen—seem to be louder than ever, but I find Mühlacker rather a difficult station because almost every time I have tried for him he has been badly heterodyned. The French stations are fairly reliable, and Poste Parisien is regularly good when clear of Hamburg. Radio Normandie is very loud but subject to rapid and violent fading; at one moment he has to be toned down and at the next, is only just audible. On the long waves Warsaw is the star turn at present. This station rolls in at good strength at any time of day, and very often blots out Eiffel Tower almost completely. His strength is very similar to that of Radio Paris, and he puts out some first rate programmes of light music. Of course, the many Russians are easily received, but they rarely give any programmes worth listening to.

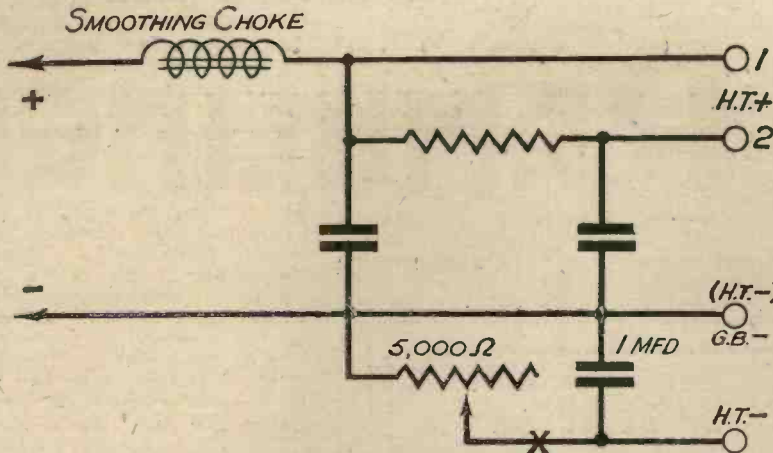

Fig. 3 (a).—One method of obtaining grid bias from an eliminator.

apply equally well to either a D.C. or A.C. instrument. The first method is to connect a variable resistance between the H.T. negative terminal of the eliminator and the corresponding terminal of the set. The previous H.T.— terminal will now supply the negative bias voltage. A 1 mfd. condenser should be connected across the resistance to provide a by-pass for alternating currents. All connections are shown in the diagram of Fig. 3 (a). By adjusting the 5,000 ohm variable resistance any G.B. voltage from 0 to 30 or so can be obtained ; in all cases the resistance should be set to the highest value consistent with good reproduction. A disadvantage of the above method is that the grid-bias voltage is taken away from the total high-tension supply, and thus, as the G.B. voltage is varied, a corresponding variation (in the opposite direction) will occur in the H.T. voltage. The latter difficulty can be overcome in the manner illustrated by Fig. 3 (b). Here the voltage drop across the smoothing choke is employed to provide negative bias. So that a variable voltage may be obtained, the choke is shunted

**Station Calibration**

It seems rather peculiar to me that so many manufacturers should be making sets with station-calibrated dials. I suppose these are all very well for people who require only comparatively few stations and who wish to obtain them in the simplest possible manner. But what will happen when stations change their wavelengths, as they are bound to do from time to time ? In my opinion the best form of calibration for a family set is that in which the tuning dial is marked off in wavelengths or frequencies. It is then only necessary to have a list of stations to make it a perfectly straightforward matter to set the dial for any one of them. This system cannot become obsolete whatever changes take place in the matter of wave-length allocation.

type of directly heated battery valves, a grid-bias battery is necessary. This is obviously a disadvantage, and I want to explain two ways of obtaining grid-bias from an ordinary H.T. eliminator ; both

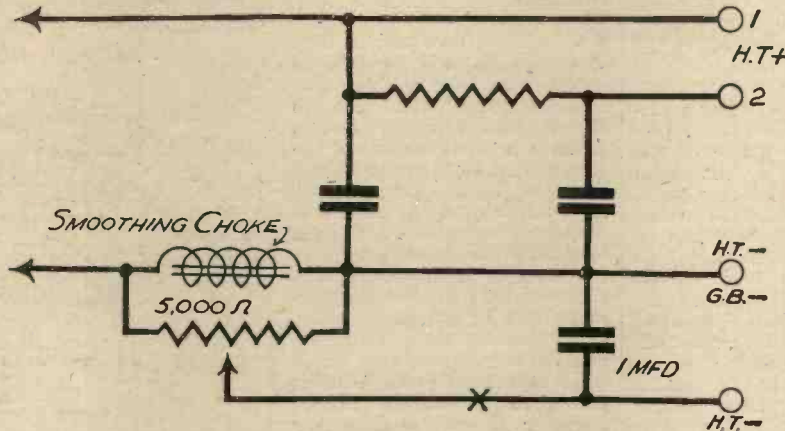

Fig. 3 (b).—Another method of adjustable grid bias.

by a 50,000 ohm potentiometer from the slider of which the negative G.B. voltage is taken. If the smoothing choke is at present wired in the positive supply lead it will have to be transferred to the negative ; it will be just as effective for smoothing purposes when put in the latter position. When using either of the arrangements described in conjunction with a sensitive receiver it might be advisable to connect a 100,000 ohm de-coupling resistance in the G.B. lead at the point marked with a cross.

**Calibrated Tuning Condensers**

This brings up another point. Why do not our manufacturers supply tuning condensers with a frequency calibrated dial ? I am sure it would be very much appreciated, and it would be easy enough to make in accurate form for use with S.L.F. condensers. Of course, the setting of the dial would depend upon the coil with which the condenser was used, but that would not offer any difficulty if the dial were made circular and marked off all round its circumference. All that would be required would be to tune in a station of known frequency, turn the dial to the appropriate setting and lock it in position. The condenser would then be calibrated for the complete wavelength range. Admittedly a second scale would be required for long and medium waves, but I do not see why the two could not be arranged for by mounting two concentric celluloid scales on a metal disc. The outer scale would be fixed to the disc but the inner one would be made so that it could be adjusted independently. I give a sketch of my idea in Fig. 2 ; by chance some reader might care to experiment with it.

**Tone Compensation**

It is well known that a pentode gives extra

emphasis to the higher notes, and for that reason it is usual to fit some kind of filter to reduce high-note response. Whilst this might be desirable in most cases, it is not necessary in a set having ultra selective tuning circuits, for the latter tend to "cut" the high notes to an appreci-

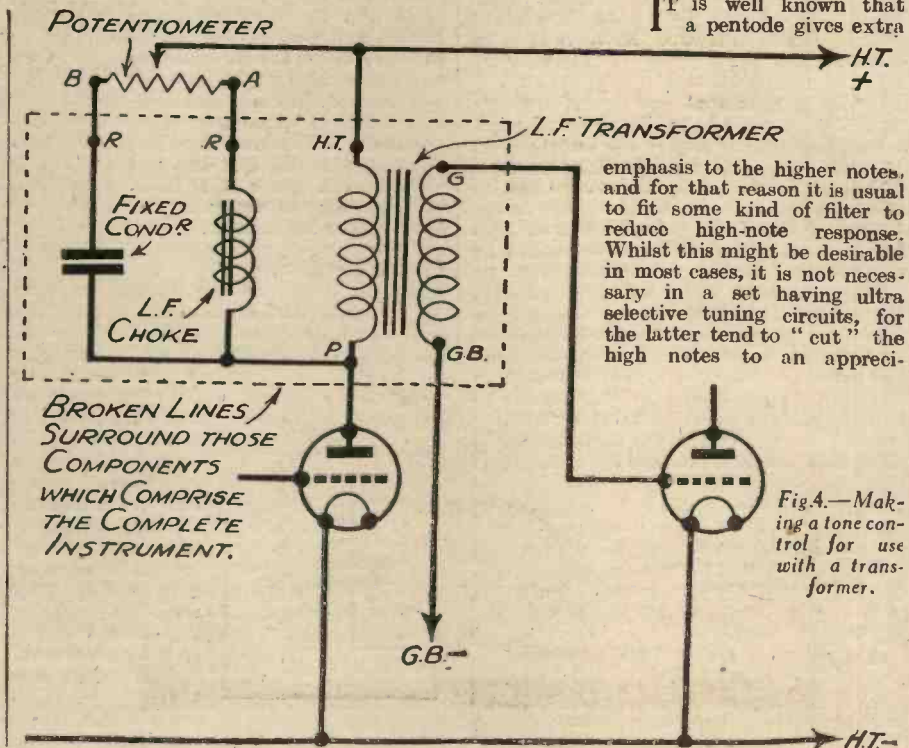

Fig. 4.—Making a tone control for use with a transformer.

**G.B. from an H.T. Eliminator**

Most high-tension eliminators have no provision for grid bias supply, and so, when used with a set having the usual

able extent. Thus, instead of using tone compensation with the pentode, the valve itself gives a fair amount of compensation to the rest of the circuit. This is worth knowing when building a simple set using one of the new highly selective tuners such as the Colvern "T.D." coil.

**Sensitivity and Power**

**J**UDGING by the wording of many of the queries received, it would appear that there is a large number of readers who imagine that the words "sensitive" and "powerful," as applied to a wireless receiver, have the same meaning. This is not so; the word sensitive is applied to the high-frequency and detector end of the set, whilst the word power is used in reference to the low-frequency portion. The distinction will more readily be understood if it is pointed out that a 2 S.G.-Det. receiver would be sensitive since it would have a big range, and would respond to very feeble signals. But having no L.F. amplifying stages, the set could not be considered powerful, because it would probably be incapable of operating a loud-speaker at all. On the other hand, a Det.-2 L.F. receiver might be so designed that it would receive only the local station, but it would probably bring in that station at full strength on the loud-speaker. For that reason the set would be considered powerful.

The "How" and "Why" of Tone Control I HAVE been asked a few times lately to explain how a tone control transformer functions. Before giving a direct answer, I must make it clear that the tone-control transformer really consists of three components housed together in the same container; these are (1) an ordinary L.F.

transformer, (2) a small L.F. choke, and (3) a fixed condenser. The way in which they are wired up is shown in Fig. 4, and it will be seen that one side of both the choke and the condenser is connected to the plate end of the transformer primary. An external potentiometer (generally .25 megohm or so) is joined between the other end of these components, and the slider is connected to H.T. positive. When the potentiometer slider is moved to the end marked "A" the L.F. choke is put in parallel with the transformer primary, but when moved to position "B," the fixed condenser is in parallel with the primary. By moving the potentiometer slider between ends "A" and "B," the choke and condenser are made to have varying effects on the primary winding. Now the effect of the choke is to reduce the inductance of the plate circuit, and as the inductance is reduced the lower frequencies are able to leak away through the plate circuit, and so escape amplification. The condenser acts in reverse fashion by providing a leakage path for the higher musical frequencies. It will thus be clear that either high or low notes can be suppressed (or reduced in intensity) by adjusting the potentiometer.

Some T.C. transformers are intended only for reducing low-note amplification, and they have no effect whatever on high notes. These have an L.F. choke, and series variable resistance connected across the transformer primary. Adjustment of the resistance varies the effect of the choke on the plate circuit.

**Pentode Corrector**

**B**Y the way, you might be interested to know that Messrs. Telsen have recently introduced a "Pentode Tone-Compensator." It consists only of a 25,000-ohm resistance, and .01 mfd. condenser joined in series and housed in a bakelite case, but it makes a very convenient component. The corrector is merely connected by its two terminals to the speaker terminals of the set. As it costs only 3s. 6d., it should prove a popular line.

**Suppression of Electrical Interference**

**I** AM pleased to learn that the French authorities are now introducing legislation with a view to eliminating all forms of electrical interference which at present tend to mar radio reception. It is a bold step, but I understand that it will make illegal the sale and installation of any electrical machinery which is not completely "silenced" in the electrical sense. It seems rather a pity that similar regulations cannot be made in this country, for apparently, however severe interference might be, neither the Post Office nor the B.B.C. has any real control over it. The P.O. officials can suggest remedies, and can supply cheaply the necessary apparatus for silencing, but beyond that they are powerless.

**SPECIAL NOTICE!**  
**WIRELESS CONSTRUCTOR'S**  
**ENCYCLOPEDIA.**

Readers who are qualifying for the above volume should read the special announcement on page 675 of this week's issue.

**HAVE YOU ELECTRIC LIGHT?**  
*-then why not run your set - any set - from it?*

**T.C.C.**  
**ALL-BRITISH**  
**CONDENSERS**

Ask your Dealer  
If you have any difficulty in obtaining a copy of this book, fill in the coupon and post to us with six penny stamps. We will send you a copy by return.

**CONTENTS**

- RADIO POWER UNITS — and how to build them
- NOTES ON A.C. POWER UNITS
- OPERATING RECEIVERS ON D.C. MAINS
- ELIMINATION OF INTERFERENCE
- ABOUT T.C.C. ELECTROLYTIC CONDENSERS
- FOUR T.C.C. POWER UNITS (A.C.) with full constructional Details
- ROTATING RESISTANCE CALCULATOR

**COUPON**

To Publicity Dept., The Telegraph Condenser Co., Ltd., Wales Farm Road, N. Acton, London, W.3.

Please send me a copy of your book "The Design and Construction of Radio Power Units" for which I enclose six penny stamps to cover cost and postage.

NAME.....  
ADDRESS.....  
PRAC. 34/12/32.....



## COMMENTS ON COMPONENTS

# What we Found..

### CLIX "DUAL" WANDER PLUG

THE need for an extra tapping or branch from a flexible lead is continually arising. Frequently two leads are wanted from the same point on the G.B., H.T. battery or eliminator; branch leads to another loud-speaker; an aerial extension to another set, or a quick change of connection to the other side of an aerial condenser. For all of these, and many other purposes, the new CLIX "Dual" wander plug does the job neatly and efficiently. It is really a wander-plug and socket combined, with the pin at right angles to the socket, thus forming a branch, or three-way connector. It is made in the usual Clix style, with a pin which will always make firm contact, doesn't lose its "set." Supplied in red or



The Clix "Dual" wander-plug, showing how two leads may be taken from one socket.

black. Full range of markings, at the popular price of 2d. each; a half-dozen of these should be included in everybody's kit. Lectro Linx Ltd., 254, Vauxhall Bridge Road, London, S.W.1.

### THE BROWN H.T. BATTERY SUPERSEDER

THE provision of High Tension current for a small set is met very satisfactorily by this instrument, which operates solely from a 2-volt accumulator. It thus obviates the need for H.T. batteries, and gives always a current of even voltage. The principle is that of an A.C.—D.C. vibratory converter, combined with a transformer which steps up the pressure to about 100 volts. The transformer output is rectified by means of a Westinghouse metal rectifier, and smoothed by means of chokes and large-capacity condensers. A potential divider is tapped and connected to four sockets for H.T. negative, and positive 35, 55, and 40 volts. A switch is also incorporated. The entire apparatus, mounted on bakelite base with screening cover, occupies less space than the usual 60-volt dry battery, its size being only 7in. by 4 1/2in. by 3 1/2in. It is sold only by Electradix Radios, 218, Upper Thames Street, London, E.C.4, and is a remarkable bargain at the price of 37s. 6d.

### BULGIN REMOTE CONTROL UNIT

FOR those who require a really luxurious arrangement, a Bulgin remote control is the thing. The mere insertion of the loud-speaker plug into its jack operates the unit, and the set is automatically switched on. Removing the plug when finished causes it to switch off again. The unit comprises a simple relay, which is operated by a small current from the L.T. battery. A ruby glass indicator shows when the set is "on" or "off." The current consumption need hardly be considered, for it is a mere .06 ampere. The Remote Control Unit is made by A. F. Bulgin & Co., Abbey Road, Barking, London, E., and costs 10s. 6d.

### CLARION RADIO FURNITURE

A CABINET for the new set. Does this matter always get the consideration it deserves? We think not. And yet, what is the sense of constructing a receiver which performs excellently, and then fitting it into a box of crude design and worse finish, stamping it indelibly as an amateur production? And yet this is so often done.

The "1933" catalogue of Clarion Radio Furniture will open your eyes as to the possibilities of the home-constructed set, listing, as it does, a variety of cabinets to suit all tastes and pockets. There is the "Classic"—

included. Many constructors will be interested in the "chassis," on which the set can be built. It incorporates the baffle board for loud-speaker, and fits various Clarion cabinets, or can be used for the adaptation of one's own furniture. So, before settling about your new cabinet, send for the catalogue to Clarion Radio Furniture, 28-30, Mansford Street, London, E.2.

### THE BULGIN H.F. MAINS CHOKE

INTERFERENCE, in its many forms, does not always get into the set *via* the aerial, but often through the medium of the mains unit. The special H.F. mains choke made by A. F. Bulgin & Co., is specially designed to stop H.F. currents arriving through the mains. The choke should be placed in one of the leads feeding the eliminator, with a condenser (about .01 mfd.) connected at either end, and the free terminals of the condensers connected to earth. The choke has an inductance of 40,000 micro-henries, and a D.C. resistance of 120 ohms. There will thus be a drop of potential of only 1 volt for each 8 milliamps carried. The instrument is housed in a green bakelite case, and has interlocked terminals. Its carrying capacity is 100 milliamps. The cost is 7s. 6d.

The H.F. Dual Mains Choke is specially suitable for D.C. valves, and is connected to both poles of the mains. With a D.C. resistance of 64 ohms, it will drop 16 volts at .25 amp., and has an inductance of the order of 60,000 microhenries. It is housed in a universal mounting, aluminium finished screening case, and is moderately priced at 10/-.

### BRITISH GENERAL H.F. CHOKE

A GOOD H.F. Choke is a component which can be put to many uses, and this particular choke is certainly a high-class article. The windings are protected by a nicely finished, non-corroding, moulded case, which keeps out damp and dust. The actual windings have a resistance of only 400 ohms, yet the inductance is of the order of 128,000 microhenries. The method of winding gives the low self-capacity of 4.5 micro-microfarads, so that the choke would be quite efficient for H.F. coupling purposes, even in the anode circuit of a screen-grid valve. The price is 6s. 6d., which, of course, is very reasonable for a component of this nature.

### PLATELESS ACCUMULATOR

IN our issue dated 3rd December, we described under this heading a new type of extremely efficient plateless storage battery. We attributed this product to the firm of Fuller, owing to the association of that



name with the block type of battery. We understand, however, that this is not the case. The Block Batteries referred to are the sole property of Block Batteries, Ltd., and not the Fuller Accumulator Co., and we hasten to correct this inaccuracy. Mr. L. Fuller, the inventor of the original Fuller Block battery, has severed his connection with the Fuller Accumulator Co., and is now a director of Block Batteries, Ltd., and it was due to the association of his name that the misunderstanding occurred. There is no connection between the two firms.

### HELLESENS CONDENSERS

THE firm of Hellekens are well-known as manufacturers of various types of battery, as well as condensers. We have received a very interesting range of condensers from this firm, the most interesting of which are the electrolytic condensers in dry form. These are shaped in the same manner as the well-known 2 mfd. condensers, and are cased with waxed cardboard. The connections are brought out as long flex leads, the two coverings being red and black for identification purposes. The anode of these condensers consists of pure aluminium foil, on which is formed, electrochemically, a very thin film for dielectric purposes. The cathode is also of aluminium in a paste electrolyte. The condenser may be mounted in any position, and although no mounting lugs or other devices are fitted, it will not be found difficult to secure it in a receiver. These condensers are also available as blocks, having two or more positive leads and one common negative lead, and will be found very convenient for use in the construction of mains units.

### HEYBERD TRICKLE CHARGER

THERE is a great deal of disappointment when the accumulator suddenly ceases to function in the middle of an interesting item. In addition, there is a certain amount of inconvenience in carrying an accumulator to the charging station, especially if the accumulator chances to be one of the larger 6-volt types and the station is situated some distance away. The Trickle Charger does away with all worries attending the charging question, and in addition keeps the battery in good condition by permitting regular and constant charging. The charger illustrated is the new Heyberd Model A.O.2, which delivers .5 amp. The method of building up this charger is very unique, the base consisting of a standard Heyberd Mains Transformer, upon which is bolted a Westinghouse Metal Rectifier. A terminal strip at one end of the instrument enables the charger to be connected to mains of any voltage from 200 to 250, and at the opposite end of the instrument a terminal strip is provided with four terminals—a common negative, and positive terminals for 2, 4 or 6 volt accumulators. There is therefore absolutely nothing to understand in using this type of instrument, and the metal box shown on the left of the illustration goes over the rectifier and completely screens it. The holes enable ample ventilation to be obtained and keeps the rectifier cool. On test the current was found to be a full 1/2 amp., and at the price of 35s. this is a most valuable accessory. A larger model giving 1 amp. at 6 or 12 volts is also obtainable at 42s. 6d.



The Heyberd A.O.2 half-amp. charger, with cover removed.



# Practical Letters from Readers.

The Editor does not necessarily agree with opinions expressed by his correspondents

### That Heterodyne

SIR,—First of all, let me thank you for PRACTICAL WIRELESS. I have been connected with radio since 1915, from which date I served as a sea-going operator until 1925. Since then I have found considerable interest in the construction of many receivers. I am also a keen short-wave listener, my knowledge of morse making this waveband extremely interesting. Your publication is indeed practical, and I commend it to anyone wishing for a more comprehensive knowledge of wireless. For the benefit, possibly, of other readers, will you please qualify the following statements in your issue of 5th ult., Vol. 1, No. 7.

On page 322, under the heading, "Frequency Separation," you deal with the difficulty some stations experience in keeping to the 9 kc/s separation, and the consequent interference experienced by listeners due to heterodyning. The last sentence reads: "In such cases interference is inevitable, and we listeners can do nothing to overcome it."

Turning to page 352 of the same issue you describe a heterodyne stopper. You here explain how the heterodyne whistle can be removed, either by tone control or "stopper," in the anode circuit of the detector-valve. Again turning to page 358, in reply to W. H. G. (Paddington) you refer to the heterodyning of London Regional by a German station, and then state, "this cannot be cured from the receiver end."

Have I "slipped up" somewhere, or are these contradictions? The theoretical explaining of how the "stopper" works is sound, but why conflicting statements on pages 322 and 358?

I again thank you for an extremely interesting publication, and wish you all success. While you keep to your present policy of not dealing with programme criticism and continue to publish circuits which are more likely to suit we people of small bank balances, I guess you'll go right ahead.—A. W. MANN (Petworth).

P.S.—I was glad to read how W. B. Richardson puts your correspondent, Maxwell Smith, of Thornton Heath, wisc. Surely a strip of hot air. Very cute that last sentence.

### A Club Member's Thanks

SIR,—I have read with great interest the varied articles in PRACTICAL WIRELESS. As a member of a local club, with a membership of over eighty, your weekly talks dealing with the functions of the various

components of a receiver appeals to me immensely. How many constructors know the actual working of their sets? Your weekly article solves the problem, and should be read out to members each week. There is one point I miss in nearly all wireless journals, i.e., coil construction. This is what we want badly, and I would be pleased to see a series of articles on how to make tuning coils in your splendid radio journal.—V. HARVEY (Cardiff).

[We have in hand one or two articles on coil-making which will be published shortly.—Ed.]

### A Bouquet

SIR,—I feel that it would be rather churlish of me to withhold my thanks to you for your remarkably good journal, PRACTICAL WIRELESS. I have just finished reading through No. 7, and I find it even richer, if possible, in really useful information than its predecessors. Indeed, for the past six weeks, those issues have provided me with the most interesting and instructive evenings I can remember to have had for the past twenty years, and that is saying something.

Fellows like myself, who regard wireless

CUT THIS OUT EACH WEEK

## DO YOU KNOW?

—THAT an air-spaced coil is more efficient than one wound with the wire in contact with the coil former.

—THAT an S.G. potentiometer and a gramophone volume control may be ganged together to reduce the controls on the panel.

—THAT an earth screen between the windings of a mains transformer reduces the tendency to hum interference.

—THAT special test records bearing all the instruments of the orchestra are obtainable for test purposes.

—THAT a milliammeter in the anode circuit of the detector valve provides a certain method of showing the correct tuning point.

—THAT the glass of a window may be used as the dielectric of a coupling condenser for series aerial tuning.

—THAT records which have warped may be straightened by placing between glass sheets in a warm place.

### NOTICE

The Editor will be pleased to consider articles of a practical nature suitable for publication in PRACTICAL WIRELESS. Such articles should be written on one side of the paper only, and should contain the name and address of the sender. Whilst the Editor does not hold himself responsible for manuscripts, every effort will be made to return them if a stamped and addressed envelope is enclosed. All correspondence intended for the Editor should be addressed: The Editor, PRACTICAL WIRELESS, Geo. Newnes, Ltd., 8-11, Southampton Street, Strand, W.C.2.

Owing to the rapid progress in the design of wireless apparatus and to our efforts to keep our readers in touch with the latest developments, we give no warranty that apparatus described in our columns is not the subject of letters patent.

as the finest hobby of the age, and who take it rather seriously, are indeed fortunate to have at our elbow such a valuable guide.

I like the clarity, and the smooth, intimate style of your writers, and the knowledge contained is very easily assimilated. You have, indeed, a fine set of contributors. Might I ask for something?

1. That your journal will never alter its style.

2. That it may go a little deeper into technicalities, and the mathematics of wireless.

3. That you give us some more "How to make" articles.

I should also like to have explained such matters as "side bands, side band cut-off," and why, as it is said, band-pass tuning results in side-band cut-off. And could you, some day, give us a clear exposition of the paths of the current through, say, a three-valve set? I am also subscribing to the *Newnes Complete Wireless* which I find to be of the same high standard as PRACTICAL WIRELESS. Again, thank you for your very fine journal.—H. E. BURROWS (Warrington).

### More Congratulations

SIR,—I have much pleasure in offering my congratulations on your production of an excellent wireless paper. I have read each of the first eight numbers, and have obtained as much technical reading material from each as from a monthly journal priced at 1s. I have given a permanent order for your paper, and wish you every success for the future.—H. PARKINSON, B.Sc. (Wigan).

### A Wireless Traders' Appreciation

SIR,—As a wireless trader I think I ought to know a little respecting radio, both theoretical and practical. I have taken wireless journals since the early days of radio, but until your first publication I cannot recollect a periodical which so ably assists the wireless amateur, and in addition refreshes the minds of one or two of the old hands. Wishing your journal every success.—F. W. T. BAKER (Wolverhampton).

### A Plea for Portables

SIR,—May I suggest that your experts design a simple four-valve portable, for whilst there are plenty of circuits published that deal with ordinary sets the portable receives little and inadequate treatment. I have searched for some time for a really good circuit that will meet the requirements of the intelligent amateur, and I have been baffled. I have made up the portables designed by other experts from time to time and either they have had insufficient power or they are hopelessly unstable.—V. BENYON-HARRIS (Matlock).

# HOME CHARGING



Why not charge your accumulators in your own kitchen? Simply connect one side of the Heayberd Battery Charger to the Mains—the other to your accumulator. You will save money, time and trouble this way. And... your L.T. Batteries will last much longer.

Model A.O.2. Charging 2, 4 or 6 volts at 1 amp. ... 35/-  
Model A.O.3. Charging 2, 6 or 12 volts at 1 amp. ... 42/6

Both models incorporate Heayberd Transformer and Westinghouse Rectifier. Complete in neat steel case—no external resistances required.



## Post Coupon

for Heayberd handbook on Mains Working

I enclose 3d stamps for New Handbook of Mains Equipment. Packed with Technical Tips, Service Hints and diagrams!

Mr. \_\_\_\_\_  
Address \_\_\_\_\_

PRA.

**F.C. HEYBERD & Co.,**  
10 FINSBURY STREET, LONDON, E.C.2  
One minute from Moorgate Stn

DESIGNS FOR APPARATUS FOR ANY RADIO PURPOSE, INCLUDING TRANSMISSION. OVERSEAS ENQUIRIES INVITED: ANY APPARATUS SUPPLIED. CONSTRUCTIONAL WORK UNDERTAKEN.

We undertake to solve your Problems, including obtaining Amateur Transmitting Licence. Whatever your difficulty, write us.

Charges: 3/- per query, four or more, 2/6 each, with diagrams. Radio Technical Agency (Dept. P.L.W.), 2, Westgate Chambers, Newport, Mon.

**LOUD SPEAKERS REPAIRED, 4/**  
(Blue Spot a Speciality, 5/-)  
Transformers 4/-, all repairs magnetised free. Eliminator Repairs quoted for. 24 Hours Service. Discount for Trade. Clerkwell 9069.  
**E O' MASON, 44, EAST ROAD, LONDON, N.1.**

**TRANSFORMERS.** Large quantity of genuine Ericsson Transformers. New and guaranteed. List price, 17/6 each. Ratios 2-1 and 4-1. Our price, 3/3 each. E.T.A. General purpose valves, Type B Y 1814. List price, 5/6. Max. Fil. volt 2.0v. Fil. cur. 0.12 amp. Mx. Anode vol. 150v., Ampl. factor 18, Imped. 14,000 ohms, Mut. cond. (slope) 1.3 m.a./v., Aver. anode current 3 m.a. (For 150v. anode current and -2.5 G.B.) Limited number only for quick sale, each 2/6. Snap up these bargains whilst stocks last! Carriage paid U.K., cash with order.—Pioneer Radio Manufacturing Co., Ltd., Goptio Street, New Oxford Street, W.C. Museum 9607. Trade enquiries invited.

## Practical Letters from Readers

(Continued from page 707.)

### Fuses

SIR,—Thanks for a very sensible paper. PRACTICAL WIRELESS is on order, and I hope it will always be. It is very helpful and clear, and the sketches are well desired. I have been asked to write to you by several for a whole page on an important subject—Fuses—their working, position, rating, etc. Such an article would no doubt help to save pounds. No journal has yet given a comprehensive article on fuses, so please! Also an article on all types of switches, and their uses, would be appreciated. Thanks again.—R. C. (Liverpool).  
[An article is in hand for early publication.—Ed.]

### Moving-Coil Loud-Speakers: A Correction

SIR,—I note with satisfaction that you have published my article re switching of alternative loud-speakers, in your current issue under "Practical Pars." I would point out, however, a slight error in the text which may cause some confusion in the minds of your readers.

In the third para. from the end "two moving-coil type of loud-speakers" should read "two moving-iron type of loud-speakers."—FRANCIS S. J. COOPER (Brixton).

### Testing Polarity of Mains

SIR,—I do not consider by any means that the coupling of a receiver or eliminator, as stated in your Nov. 12th issue, is as dangerous as the pole-finding test described in PRACTICAL WIRELESS a week or two ago. The reasons for this are obvious, coupling

any electrical appliance to the mains, amateur or professional alike with sense, rather than work with live wires, takes off the power. In the pole-finding test described he is handling live leads. I admit the fuse may blow in case of a short circuit, but even that takes time, the experimenter may not trouble to note size of fuse, even electricians are sometimes careless. It is quite possible for anyone not used to this sort of thing to short the leads, resulting, perhaps, in a shock or burnt fingers. Why this risk when the remedy is so simple? I suggest a 60-watt lamp or other suitable resistance in circuit with one lead, then, of course, the most serious thing one can do is, light the lamp, and the danger in handling the wires is considerably reduced.

I find that after fifteen years' practical experience it is much better to be sure than sorry. I may add I am not really a nervous fellow myself. I hope in the interest of readers and PRACTICAL WIRELESS you will give this space and I heartily wish your paper every success.—V. P. BROWN (Hollinwood).

[We can only reiterate what we have already said on this subject.—Ed.]

### A Gold Mine

SIR,—I am a very interested reader of your paper, PRACTICAL WIRELESS, and would like to add my congratulations and thanks, to others, for such an abundantly interesting book.

I think that many readers, like myself, are not always experimenting, but very much wish to improve their general knowledge of electricity, etc., as applied to wireless, and this paper supplies the means.

(Continued on page 709.)

# STAGGERING OFFER TO HOME RADIO CONSTRUCTORS

## AMAZING 84/- SET for 3

### THE FAMOUS SLEKTUN SCOUT S.G.3 "50 Stations" KIT

At a GREAT REDUCTION for Xmas!

The famous "Slektun" Scout Screened Grid 3-valve Kit Receiver, already built by thousands of enthusiastic constructors all over the country and formerly sold at 84/- is now offered to YOU for £3.

The Cabaret Electric Co., Ltd., to commemorate the opening of a magnificent new branch at 122, Vauxhall Bridge Road, are able to make you this amazing offer for a limited period only, having purchased a huge quantity. Earliest application for one of these splendid kits is strongly advised.

Every kit includes the exact components originally specified by the designer, and is supplied complete with baseboard and ebonite panel cut to size and ready drilled, together with all necessary terminals, wire and flex, full-size blue-print and illustrated construction guide.



### COMPLETE KIT

includes the famous Slektun Super Transformer, Slektun Dual Range Coils, Gridiron Ganged Condenser with Sector Vision Escutcheon, T.C.C. Fixed Condensers, W.B. Valve Holders and Switches, Ready Drilled Panel and Terminal Strip of "Permal" non-discolourable Ebonite. Baseboard Assembly covered with "Konductite" metallic screening material. All necessary screws, terminals, connecting wire, wander plugs and flex.

This is a wonderful chance to secure this fine set in time for Christmas as a lasting gift to yourself and your family.

**CABARET ELECTRIC COMPANY, LTD.**  
182, VAUXHALL BRIDGE ROAD, LONDON, S.W.1  
and 238, High Road, Lewisham, S.E.3

★ Write for Leaflet To-day.



**Practical Letters from Readers**

(Continued from page 708.)

I hope there is enough material left to keep it up to standard of interest for a long time to come.

The Encyclopædia will be a gold-mine to many.—S. LAURIE (Seven Kings).

**A Home Constructor's Thanks**

SIR,—It usually requires a great effort for me to sit down and write a letter, but this time it seems somewhat of a pleasure. From the crystal-set days I have been interested in wireless, and have derived a lot of pleasure in making and using same. When it came to valve-sets, I was stumped. I now look forward to Wednesday, because of your paper, which gives me more satisfaction than any other weekly paper I have ever picked up. I am looking very eagerly forward to the time when I get the "Wireless Constructor's Encyclopædia." It has occurred to me that a set might be designed that could be converted to varying requirements, such as a S.G.4. By pulling out a knob on the front panel, it could be converted into a S.G.3, and by pulling out another knob, a straight-two set; then again, by pushing in the first knob, it is converted into a straight-three. To those using batteries, it would be a saving in H.T. and L.T. current, as the local station is tuned in the most, and two valves will do that on the loud-speaker. Wishing PRACTICAL WIRELESS the greatest success.—H. PALETHORPE (Bromley).

**The S.G. Amplifier**

SIR,—Your correspondent, Mr. Harold Stripe, in his letter on the above subject in the issue of PRACTICAL WIRELESS, in endeavouring to correct L. F. Thomas, does not himself present a true solution of the problem.

It is required to determine the voltage applied to the screening-grid of a valve, through a fixed potentiometer consisting of upper and lower arms, made up of resistances of 30,000 ohms and 50,000 ohms respectively. Although your correspondent reaches the conclusion that the upper and lower arms of the potentiometer do not pass the same current, yet his first step, when ascertaining the voltage applied to the screening-grid, is "Find the total current passed by the potentiometer by dividing its resistance into the battery voltage."

Suppose the current taken by the screening-grid to be 0.6 milliamps, and that passed by the potentiometer to be p milliamps; then the total current passed by the upper arm will be (0.6 + p) milliamps, and the voltage drop across the resistance (30,000 ohms) will be  $\frac{(0.6 + p)}{1,000} \times 30,000 = (18 + 30 p)$  volts. The total current passed by the lower arm of the potentiometer is p milliamps, and the voltage drop across the resistance (50,000 ohms) will be  $\frac{p}{1,000} \times 50,000 = 50 p$  volts. Clearly, the sum of these two voltages must be equal to the battery voltage, which is assumed to be 150 volts, so that we have  $(18 + 30 p) + 50 p = 150$ , from which it follows that  $p = 1.65$  milliamps. This is the total current passed by the lower arm of the potentiometer, and the voltage drop across the resistance (50,000 ohms) will be  $\frac{1.65}{1,000} \times 50,000 = 82.5$  volts.

This is the voltage applied to the screening-grid. The total current passed by the

upper arm of the potentiometer will be  $0.6 + 1.65 = 2.25$  milliamps, and the voltage drop across the resistance (30,000

ohms) will be  $\frac{2.25}{1,000} \times 30,000 = 67.5$  volts-

—IAN D. WALKER, B.Sc. (Eng.) (Broad stairs).

**Band-Pass Three Valver Wanted**

SIR,—Having decided to change over to your paper and become a regular reader, may I suggest that at some early date you publish details of an inexpensive S.G.-Det.-Power receiver incorporating band-pass tuning, as I feel sure a set of this type would meet the requirements of many home constructors, or, alternatively, perhaps you could give articles explaining how to convert ordinary sets to band-pass tuning? May I also be allowed to make another suggestion? This is, that in your description of new sets could you not give, in addition to the name of the components used in the actual set, suitable alternatives, as a number of constructors probably have several components lying idle which could be utilized without having any adverse effect on the efficient operation of the receiver? Wishing your paper every success.—E. R. STROUD (West Norwood).

**An Appreciation from the West Indies**

SIR,—I have received the first issue of your publication, PRACTICAL WIRELESS, and I must say that it is a useful contribution to wireless literature. Keep up the standard, and I think you will obtain many more readers. As far as Malaya is concerned, we can get nothing above the 200 metres band, the best is below 100 metres, and in the way of kit sets we are badly off. Now why not have a special weekly page devoted to short-wave work in general, and give us a Kit Set to build composed of the latest and best components, say, once a year, and in this respect I give you the government ruling, which is strictly enforced here, this is that no receiver can be licensed unless the "first stage is high-frequency with a screening-grid valve." Thus you will realise that the majority of the so-called "all wavers" are useless as far as this country is concerned.—W. M. EDWARDS (Penang, S.S.).

**RADIO TERMS ILLUSTRATED**



Selectivity  
Courtesy of Elex Products

To ensure perfect contact, Clix were SPECIFIED for the SUPERHETERODYNE CONVERTOR

Clix supplies the finest range of Contact components in existence. Write now for Folder "N," giving details of over 28 components necessary for efficient contact. Free on request.

Lectro Linx Ltd., 254, Vauxhall Bridge Rd., S.W. 1

**EASY TERMS PROMPT DELIVERY**

Any Blue Spot, Rola, Epoch, Sonochorde, W.B., R. & A., or Celestion Moving Coil Speaker supplied promptly.

Send 5/- only

and pay the balance by monthly instalments. No references. Entirely private and confidential. Write for Catalogue and details to:—

TURNADGE & PARTNERS, LTD. Ludgate House, Fleet St., London, E.C.4 Telephone: Central 1903

RECEIVERS AND THEIR RECORDS

(Continued from page 686.)

cannot be received whilst the set is actually oscillating. If these instructions are carried out, even the mere beginner will log stations with the "Kilodyne," and, especially, with the coil-tuning wavelengths around 40 metres, as on this band almost every evening British and Continental amateur experimental transmitters are working until a late hour.

The "Kilodyne Four" was tested over a period of several days, and during that time a large number of broadcasts were heard on the loud-speaker, both during daylight and the darker hours of the evening. It was a matter of satisfaction to find that regularly at 1.0 p.m., G.M.T., W3XAL, Boundbrook, N.J. (16.878 m.), was heard as it came on the air, and the transmission

was held steadily until dusk. On the same coil, W2XAD, Schenectady (19.72 m.), and DJB, Zeesen (19.737 m.), also provided good signals. Clear telephony was picked up from IAC, Coltano (Italy), and from Berlin. The harmonic of Moscow (T.U.) was also found, as well as G5SW, Chelmsford. The coil comprising the 24-50 metre wave-band gave even better results, and permitted the logging of telephony from Rugby, Cairo, and Rocky Point. Broadcast transmissions were captured from KDKA, East Pittsburgh (25.27 m.), 2RO, Rome, G5SW, DJA, Zeesen, W3XAL, Boundbrook, N.J., UOR2, Vienna, Moscow and HVJ, Vatican, as well as tests from the new Empire Broadcasters GSC and GSA, for the benefit of the African Zone. It was in this waveband that some twenty British, French, Spanish, and German Amateur

broadcasts were heard during one evening. The 40-85 m. coil also proves useful, inasmuch as it includes many high-power stations, such as WEM, New York (40.54 m.) used for the relay of broadcasts from Geneva, etc., W8XK, East Pittsburgh, again the Empire Broadcaster, Eindhoven (Holland), HVJ, Vatican, and the usual batch of Amateur experimenters to which reference has already been made. It will be noticed that the coils "overlap" and, consequently, on many occasions, where on the lower coil it may be difficult to tune in a station, it frequently happens that louder signals are obtained when using the higher one. As a matter of fact, the three coils cover all the wavelengths of real value to the listener. The medium-wave coil (250-500 metres) can be considered useful as a standby, inasmuch as it will permit the reception of a number of British and Continental broadcasts. Although, owing to the aperiodic aerial circuit it is not highly selective, it was not a difficult matter to separate the National from the Regional stations in the heart of London, and broadcasts were heard from some of the more powerful European transmitters. In general, the output from the pentode valve was sufficient for loud-speaker work even with distant signals. The "Eddystone Kilodyne Four," as a kit of component parts but without valves, accumulator, batteries, or loud-speaker, costs £7 17s. 6d., it is supplied by Stratton and Co., Ltd., Eddystone Works, Birmingham. Other models, such as the "Kilodyne All-Electric Four," working from A.C. mains, and two- and three-valve battery short-wave receivers, are also supplied by these makers. The "Eddystone Kilodyne Four" is a sound proposition, and can be strongly recommended to the radio enthusiast who wishes to explore the ether for programmes other than those put out by the Home or Continental studios.

**Just plug in!**

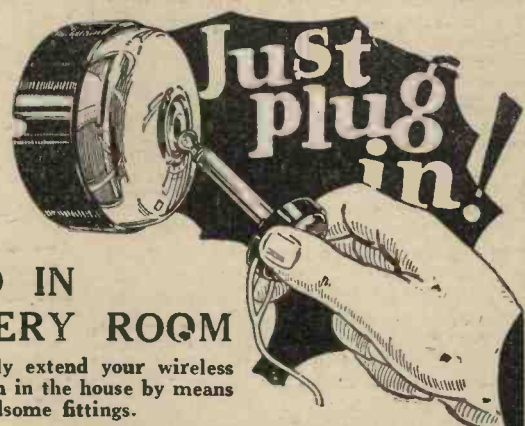

**RADIO IN EVERY ROOM**

You can easily extend your wireless to every room in the house by means of these handsome fittings. They cannot be confused with your heating or lighting points.

**BULGIN MIDGET WALL JACKS**, all insulated. Walnut or Mahogany bakelite finish. **1/6 PER POINT.**





**BULGIN JUNIOR WALL JACKS** in black or brown bakelite with nickel plated cover. **2/- PER POINT.**

STANDARD TYPE JACK PLUGS, AS ABOVE, **1/6**

THEY COST **1/6 PER POINT.**

OBTAINABLE FROM ALL DEALERS.

Full instructions for wiring given in our 80 p. Catalogue "N." Send for your copy now. Enclose 2d. postage.

 DINING ROOM
 SITTING ROOM
 BED ROOM
 KITCHEN

PATENTED No. 294765.



**A.F. BULGIN & CO., LTD.,** RADIO MANUFACTURERS, TELEPHONE: GRANGEWOOD 3266/7.



**ABBEY ROAD, BARKING, ESSEX.**

H.M.V. Super-het Ten

In view of the interest shown in the special model of the "His Master's Voice Super-het Ten Auditorium" in glass which was exhibited at Olympia, and at other radio exhibitions elsewhere, The Gramophone Co., Ltd., is manufacturing a few of these, which will be retailed at £225. The cost of the special model shown at Olympia was £300, but the experience gained with the production of the first model has enabled further instruments to be made at a lower cost. Warning is given as to the need of delicate handling of one of these sets.

**SELECTIVITY IS SIMPLE**

WITH A **FORMO** BAND-PASS TUNING ASSEMBLY



FORMO Matched Coil and Condenser Assemblies solve the problem of making your set selective. You have a complete and accurate tuning unit giving the finest possible band-pass tuning. Perfectly matched coils and condensers give accurate selectivity and much finer quality. A FORMO Matched Unit provides the home constructor with something new in performance and in straightforward set construction. Ask your dealer. Write for Catalogue in case of difficulty. **FORMO, 23, Golden Square, Piccadilly Circus, London, W.1.** Head Office & Works: Crown Works, Regents Park, Southampton.

DUAL GANG Cat. No. 72c **33/6**

TRIPLE GANG Cat. No. 69c **46/6**

**BAND-PASS ADAPTER** to bring your set up to date

A simple way to obtain adequate selectivity is with this Formo Band-Pass Filter designed by a leading wireless journal. Write for free illustrated construction details.

LET OUR TECHNICAL STAFF SOLVE YOUR PROBLEMS

REPLIES TO



QUERIES and ENQUIRIES by Our Technical Staff

The coupon on this page must be attached to every query.

If a postal reply is desired, a stamped addressed envelope must be enclosed. Every query and drawing, which is sent must bear the name and address of the sender. Send your queries to The Editor, PRACTICAL WIRELESS, Geo. Newnes, Ltd., 8-11, Southampton Street, Strand, London, W.C.2

this is obtainable from the shops or whether it can be made at home. I should be glad if you could tell me how to make it."—(R. T. G., Balham.)

The jelly electrolyte is made by dissolving sodium silicate in the ordinary acid solution. The crystals should be added slowly until jellification takes place.

SPECIAL NOTE

We wish to draw the reader's attention to the fact that the Queries Service is intended only for the solution of problems or difficulties arising from the construction of receivers described in our pages, from articles appearing in our pages, or on general wireless matters. We regret that we cannot, for obvious reasons—

- (1) Supply circuit diagrams of complete multi-valve receivers.
- (2) Suggest alterations or modifications of receivers described in our contemporaries.
- (3) Suggest alterations or modifications to commercial receivers.
- (4) Answer queries over the telephone.

probably the best of the week. I am surely not imagining things, but I do not see how the set can alter its reproduction on different nights. Perhaps one of your technical staff can offer some solution?"—(J. G., Kensington).

There is a perfectly logical explanation of the fault you are experiencing. The voltage from the mains supply should be constant, but in some localities there is a heavier load imposed on the power station on nights when all the shops are working late with their large electric displays and other lighting. This results, if the power station has a bad regulation, in a drop in the voltage supplied, and your receiver is then working with a voltage which is below that required for good quality reproduction. We think if you can measure the voltage output from your eliminator section, you will find that this is the explanation.

EXTERNAL TONE CONTROL

"I have got a commercial receiver which is built on the all-metal principle, and is a most excellent receiver in all respects. I have recently bought a new loud-speaker, and this does not satisfy me on all types of music and speech. On some things it is beautiful, but on others it is appalling. I should like to introduce some form

FOR MAINS ELIMINATORS

"I noted recently that you stated that one could use ordinary valves for full rectification in an eliminator. I am not aware how this can be done, but I should appreciate it if you could give me some instructions regarding the employment of valves in this manner."—(H. T., Harrow.)

Two ordinary valves may be employed for full-wave rectification by ignoring the grid of the valve, and employing each valve for half-wave rectification. The filaments should be wired in parallel, and the anode of each valve should be joined to the ends of the secondary, as with an ordinary full-wave rectifying valve. The filament winding must, of course, supply sufficient current for the two valves, and the centre tapings of both filament and H.T. windings are employed in the usual manner for H.T. negative and positive leads.

BAND-PASS TUNING

"I wish to try out the band-pass tuning about which so much is said in these days. Unfortunately I have got a good set, but very little spare money, so I wondered if I could, by any conceivable means, improvise such tuning with my existing apparatus. I use two tuning condensers with an H.F. stage, and, therefore, have two tuning coils. I would not mind sacrificing one tuned circuit, and would use an aperiodic H. F. stage if the band-pass tuning really improved selectivity as it is supposed to do. Perhaps you can suggest an improvisation or, at least, put my mind at rest about trying out the scheme."—(S. D., Bromley.)

You can certainly rig up a band-pass tuner, but you will have to bear in mind that the arrangement is only temporary, and should not be kept in use permanently. The two coils which you are using should be arranged so that no interaction can take place (unless they are screened), and the two coils should be joined together at one end, and that end earthed. The tuning condensers are joined across each coil in the usual manner. At the "top" end of the coils, that is, the end which is joined to Aerial and grid condenser, some form of coupling unit should be employed. This may be a small variable condenser, a variable resistance, or a fixed resistance. A value of 100,000 ohms would be suitable for a try-out. If you find that the arrangement gives you what you require, you should purchase a pair of accurately matched coils; if possible, those specially designed for band-pass circuits.

OBSOLETE COMMERCIAL SETS

"I have got the opportunity of buying a well-known commercial receiver which was very popular two or three years ago. Would it be worth while buying this and using the component parts for making an up-to-date circuit. Would I save much by doing this?"—(Y. U. J., Cardiff.)

We do not think it would be at all worth your while spending money on the obsolete set. Some of the components are, no doubt, quite good, but wireless has made such strides in the last two or three years, that much more efficient components are now available for less than you would probably be paying for the parts in the set in question. We do not, therefore, advise you to carry out your idea.

ERRATIC REACTION

"Lately, I have converted my Det. L.F. receiver from a plug-in coil to a Dual Range coil tuning. Now I find, while reaction is smooth and even throughout the medium waves, it is only obtainable up to 10 degrees on the high waves. Do you think it is the fault of the receiver, or the new coil? The reaction condenser is the one matched with the coil."—(M. F. B., Taunton.)

As the condenser you are using is the one intended for the coil, it is obviously of the right value. The fact that it does not work on the long waves would tend to show that the anode load is not of the correct value, and this may give rise to a rather high voltage drop. You should, therefore, vary the value of the high-tension applied to this valve, and we think you will soon cure your trouble.

THE EARTH CONNECTION

"I have been reading your article on Earths. As I live in the front of the house and the nearest earth is about 25 feet away, do you think that would be too much for my set, as I have only got a gas-pipe earth nearest my set. If I tried the garden, it would be about 30 feet away. When I get a foreign station it is loud, and then it will go quiet and then loud again and so on. Do you think you could solve this for me?"—(A., King's Cross.)

The earth which you are now using (the gas-pipe) may be a better one than the long lead to the garden, but the only way to satisfy yourself on this point is to try out both of them. The gas-pipe may be nearer, but may also be less efficient, whilst on the other hand, although a long lead will be required to the garden, the ultimate connection may prove more effective. The variation in strength to which you refer is probably only caused by fading, and this cannot be cured by anything you can do. It can be minimized by fitting a more powerful receiver, but then the signal will still vary in strength, although you may provide sufficient amplification to enable the weakest signal to provide sufficient loud-speaker strength.

THE A.C.—D.C. UNIT.

"Having constructed your A.C.—D.C. Eliminator, as described last week, could you tell me the approximate output in milliamps when working same from 150 volts D.C.?"—(A. O., Leyton.)

The Output on terminal No. 3 will be about 100 volts at 9 m.a. If you take more current, the voltage will drop; if less, then the voltage will rise. If you require a higher voltage, use a 2,500 ohms (or less) resistance in place of the 5,000 ohms resistance which was recommended. Make sure, however, that it is rated for the current to be used.

MAINS VARIATION

"I have a fairly good all-mains receiver, which takes a rather large current. I have noticed repeatedly that on some occasions the quality is not up to the standard usually given by this set. The principal time when reception is marred is on Saturday nights. On Sunday nights the reception seems very good, in fact,

of tone adjustment, but I must emphasize that I do not wish to interfere with the inside of the receiver. I wonder whether you can tell me in a few words how to introduce this form of control."—(H. Y. T., Bognor.)

The simplest method for your case is to include across the output terminals a variable resistance and a fixed condenser. The value of the condenser is .01, and the resistance should have a value of 10,000 ohms. The actual values may, of course, be modified to suit your speaker and output arrangements. The two components should be joined in series, that is, one terminal of the resistance joined to one terminal of the output; the other terminal of the resistance then joined to one side of the condenser; the other terminal of the condenser is then joined to the remaining output terminal. The speaker is joined in the usual way. Adjustment of the resistance will vary the tone to suit your requirements.

JELLY ELECTROLYTE

"I have made up a portable receiver, and in order to complete the design I wish to instal a small accumulator of the unspillable type. I have an ordinary accumulator by me, which is quite all right for size, but it is not of the unspillable type. I should like to fill it with the jelly acid, but am doubtful whether

DATA SHEET No. 14

Cut this out each week and paste it in a notebook.

ACID DILUTION FOR ACCUMULATORS

Specific Gravity Required.	Acid of 1.400 S.G.		Acid of 1.840 S.G.		Water.	
	Parts by Volume.	Parts by Volume.	Parts by Volume.	Parts by Volume.	Parts by Volume.	Parts by Volume.
1.225	—	10	—	29	—	—
1.250	—	10	—	27	—	—
1.256	10	—	—	6.75	—	—
1.265	10	—	—	6.65	—	—
1.275	10	—	—	6.4	—	—
1.280	10	—	—	6.25	—	—
1.300	10	—	—	5.5	—	—
1.350	10	—	—	4.5	—	—
1.400	—	10	—	21	—	—
	—	10	—	18	—	—
	—	10	—	14	—	—

FREE ADVICE BUREAU COUPON

This coupon is available until Dec. 31st, 1932, and must be attached to all letters containing queries.

PRACTICAL WIRELESS, 24/12/32.

# CATALOGUES RECEIVED

To save readers trouble, we undertake to send on catalogues of any of our advertisers. Merely state, on a postcard, the names of the firms from whom you require catalogues, and address it to "Catalogue," PRACTICAL WIRELESS, Geo. Neunce, Ltd., 8-11, Southampton St., Strand, London, W.C.2. Where advertisers make a charge, or require postage, this should be enclosed.

**FERRANTI WIRE-WOUND RESISTANCES**  
 We are informed by Messrs. Ferranti, Ltd., that they are now manufacturing their standard Cartridge Type Wire-Wound Resistance, "W" pattern, as well as the new Fixed Type "F," in the 750 ohm size. The price of the Interchangeable Type with holder is 3s. 9d., or without holder, 2s. 9d.; and the price of the corresponding fixed type is 3s. 3d. These, as well as their other wire-wound types, are suitable for a dissipation of up to 24 watts, the resistance element being wound on a sectionalised moulded bobbin with silk insulated wire. Their accuracy is within 5 per cent. of the rated value. Details of other resistances and a full range of other Ferranti components are given in their list K1. The address is Hollinwood, Lancashire.

**CLARION RADIO CABINETS**  
 A WIDE range of Receiver, Radiogram and Loud-speaker Cabinets is given in a well printed brochure just issued by Clarion Radio Furniture Co., 28-38, Mansford Street, London, E.2. There are Table Grand Models, Consolette Cabinets, and a new type of "All Square" cabinets of very attractive design. Another innovation is a new Radiogram Cabinet of futurist design. Made in oak, French-polished, and with black feet, it will accommodate any modern chassis set, and make a handsome piece of furniture. Many other patterns of cabinets to suit all requirements are included in the brochure, a copy of which can be obtained on application to above address.

**EEXLEX PRODUCTS**  
 TO home constructors the Eelex system of Standardised Plugs and Sockets is a boon. Particularly useful is the Eelex Treble Duty Terminal which can be used as a pillar or 'phone terminal, and which also takes eye, pin, and spade adaptor ends. The head of the terminal is non-detachable, and is fitted with a replaceable indicating ring. Many other types of well-finished plugs, sockets, adaptor ends, and connectors are listed in a well-illustrated booklet we have received from J. J. Eastick and Sons, the

manufacturers of these handy fittings. Also included in the booklet are a range of Eelex knife switches, one-hole fixing panel switches of very compact design, and miniature tumbler switches. Full particulars are also given of the Eelex Short-Wave Adaptor, an efficient unit working on the super-het. principle, and priced at £3. Every home constructor should have a copy of this useful booklet to hand. The address is Eelex House, 118, Bunhill Row, London, E.C.

**EPOCH LOUD-SPEAKERS.**  
 A FINE range of moving-coil speakers is given in the latest catalogue issued by Epoch Radio Manufacturing Co., Ltd. Amongst the various instruments listed is model 99k, a permanent magnet speaker with a sensitivity of a very high order. This speaker is fitted with an interchangeable diaphragm. There are also model E8, a powerful D.C. speaker designed for incorporating in modern A.C. sets where the field coil can be used as a smoothing choke; and model D2s, a powerful unit for heavy work, and capable of handling 10 watts undistorted input. Interchangeable diaphragms in three tonal characteristics are available for this speaker, and a useful impedance matching chart printed in the catalogue shows at a glance the diaphragm suitable for the required transformer ratio and valve impedance. The address is Exmouth House, Exmouth Street, London, E.C.1.

## Broadcast Query Corner

UNDER the above title, with the assistance of a recognized authority on foreign broadcasting matters and a regular contributor to wireless publications both at home and abroad, we are inaugurating a special Identification Service, which should prove of great assistance to our readers. When tuning in well-known stations it happens frequently that listeners pick up wireless transmissions of which they fail to recognize the origin. It is to solve these little problems that the *Broadcast Query Service* has been organized.

Although the service is mainly applicable to broadcasting stations, wherever possible replies will be given in regard to morse transmitters (commercial stations, fog beacons, etc.) and short-wave broadcasts. For the identification, however, of stations operating on channels below 100 metres it will be evident to inquirers that a closer estimate of wavelength must be submitted than in the case of broadcasts on the medium or long waveband if successful identification is to be carried out.  
 All inquiries should be addressed to *The Editor*,

PRACTICAL WIRELESS, 8-11, Southampton Street, Strand, London, W.C.2, and the envelope marked *Broadcast Query Service*, in top left-hand corner. Stamped addressed envelope should *not* be enclosed, as replies cannot be sent by post, but will be published in due course, in each issue of PRACTICAL WIRELESS.

## Replies to Broadcast Queries

ZIPANTI (Edinburgh): Geneva (760 m.); although only 1½ kilowatt, it is sometimes well heard. B. McCauley (St. Johnston): Cannot trace transmitter for lack of detail, but ship-shore telephony (on about 220 m.). NELSON (Stepney): (4) WTAM, Cleveland (Ohio) National Broadcasting Company network on 280.2 m.; (5) LR6, Radio Nacion, Buenos Aires on 345 m.; (6) WCAU, Philadelphia (Pa) Columbia Broadcasting System network (256.3 m.); (7) WTIC, Hartford (Conn) N.B.C. (282.8 m.); (8) No. LES (Liverpool): (1) (a) WCAU, Philadelphia (Pa.), on 256.3 m.; (b) WABC, New York, on 348.6 m.; (c) WJZ, Boundbrook, on 394.5 m.; (d) WJSV, Alexandria (U.S.A.), on 205.4 m. (2) (1) WBZ, Boston (Mass.), on 302.8 m.; (2) WTAM, Cleveland, (Ohio), on 280.2 m.; (3) WPG, Atlantic City (N.J.), on 272.6 m.; (4) WOR, Newark (N.J.), on 422.3 m. W. R. CLARKE (Cornwall): (1) WBZ, Boston (302.8 m.), and WIAZ on 31.35 m.; KUKU is the call sign of a mythical station adopted by the "Cuckoo" Club for a series of sketches broadcast through the National Broadcasting Company Network; (2) WABC, New York, on 348.6 m.; (3) WTAM, Cleveland (Ohio), on 280.2 m.; (4) WCAU, Philadelphia (Pa.), on 256.3 m. (5) WJZ, Boundbrook (N.Y.), on 394.5 m.; the "z" is pronounced "zee," hence your misunderstanding it for "v." ETHER SCRAPER (Poole): Warsaw. The call was: Radio Polskie Warszawa (phon: Vars-chavva), on 1,411 m. CURIOS (Nottingham): KDKA, East Pittsburgh (Pa.), and WBZ, Boston (Mass.), direct. SUPERHET (Bala): Details submitted are too vague to permit identification of transmitter but ship or shore-ship telephony (trawlers, etc.).

**The SLEKTUN "SCOUT S.G.3."**  
*Simpler than ever to build*  
**FREE** Blueprint and Illustrated Construction Guide combined. Very practical instructions for building this great set—the complete kit of which costs only 84s.—. Write for a free copy of the New Blueprint Guide, sending 3d. in stamps for postage.  
 Slektun Products Ltd., 21, Douglas St, Westminster, S.W.1



**1922-1932**  
**A DECADE DEVOTED TO BETTER RADIO CONNECTIONS**  
 Advt. of BELLING & LEE, Ltd., Cambridge Arterial Road, Enfield, Mdx.

## ADVERTISEMENT INDEX

	Page		Page
Belling & Lee Ltd.	712	Lisßen Ltd.	674
British Ebonite Co. Ltd.	673	Lectro Linx, Ltd.	709
British General Mfg. Co., Ltd.	673	London Electric Wire Co. and Smiths Ltd.	<i>Inside Front Cover</i>
British Pix Co., Ltd.	701	Mason, E. C.	708
Bulgin, A. F. & Co., Ltd.	709 and 710	Newnes' "Last Minute Gift Books"	<i>Inside Back Cover</i>
Cabaret Electric Co., Ltd.	708	Newnes' Presentation Binder	692
Cossor, A. C., Ltd.	<i>Bottom Strip and</i> 687	Pearson's Books	702
Edison Swan Electric Co., Ltd.	<i>Back Cover and</i> 701	Pioneer Radio Mfg. Co., Ltd.	708
Goodmans	702	Pressland, Clifford R. (Sales) Ltd.	701
Formo Co., Ltd.	710	Radio Technical Agency	708
Hambling, A. W., Ltd.	673	Slektun Products Ltd.	712
Heayberd, F. C. and Co.	708	Telegraph Condenser Co., Ltd.	705
Jackson Bros., Ltd.	673	Turnadge & Partners, Ltd.	709

# FOR THAT LAST-MINUTE GIFT GIVE A PRACTICAL WIRELESS BOOK

*The Wireless "Omnibus" Book*

## THE OUTLINE OF WIRELESS

by RALPH STRANGER

*Third Edition.*

**T**HIS book has been prepared for the non-technical listener. Written in simple language it explains everything about wireless from A to Z as it has never been explained before. After reading "The Outline of Wireless," your set, which a few days ago was a sealed book to you, will now be yours to do with as you will. 840 pages. Fully Illustrated.

**8/6, post free 9/-**

*Some Press Opinions:*

"Mr. Stranger . . . gives a simple, yet authentic, introduction to all the 'mysteries,' and explains them away in an exceedingly interesting and readable way. . . . A book which should go on every listener's bookshelf."—*The Star*.

"A good book simply written."—*The Daily Mirror*.

" . . . It will be surprising if such an ably-written book as this does not find a wide sale."—*Daily News*.

" . . . Mr. Stranger has succeeded in doing one thing that will endear him to all students interested in electricity. He has succeeded in making static electricity fascinating. . . . The book should prove of great value to all those who have a set or contemplate the construction of one."—*World-Radio*.

" . . . The subject, in both theoretical and practical aspects, is dealt with in a lucid manner guaranteed to inebriate knowledge without pains."—*Amateur Wireless*.

## RALPH STRANGER'S WIRELESS LIBRARY

for the

### MAN IN THE STREET

- MATTER AND ENERGY
- ELECTRONIC CURRENTS
- ELECTRIFIED MATTER
- MAGNETISM AND ELECTRO-MAGNETISM
- SEEING BY WIRELESS (TELEVISION)
- MODERN VALVES
- WIRELESS COMMUNICATION AND BROADCASTING
- WIRELESS WAVES
- HOW TO UNDERSTAND WIRELESS DIAGRAMS
- SELECTION OF WIRELESS SIGNALS
- DETECTION OF WIRELESS SIGNALS
- AMPLIFICATION OF WIRELESS SIGNALS
- REPRODUCTION OF WIRELESS SIGNALS
- WIRELESS RECEIVING CIRCUITS
- WIRELESS MEASURING INSTRUMENTS
- THE BY-PRODUCTS OF WIRELESS

**1/- each, post free 1/2**

## THE MATHEMATICS OF WIRELESS

by RALPH STRANGER

A book specially written to sweep away the greatest obstacle to the understanding of wireless—the mathematics of the subject. Original and lucid explanations of all branches of mathematics as applied to radio. Indispensable to all who would understand technical books and articles. Differential and Integral Calculus are explained at some length and the use of Logarithms and the Slide Rule clearly shown. 256 pages. Fully Illustrated.

**5/-, post free 5/3**

## WIRELESS THE MODERN MAGIC CARPET

by RALPH STRANGER

*Fourth Edition.*

If you know nothing about wireless this book will show you how to provide yourself with an interesting and absorbing hobby. If you are a listener, but rather weak on the technical side, it will save you much unnecessary worry and expense. If you wish to experiment, this volume will provide you with valuable experimental data. If you are an expert and have to lecture, it will give you some useful lecture material.

**3/6, post free 3/9**

## WIRELESS STEP BY STEP

by "DICTRON" (9th Edition)

A book which shows the wireless enthusiast how to obtain the maximum enjoyment from his wireless set. A practical book, expert in range, yet clear and concise in presentation. It explains in simple language the principles of radio communication. Its delightful simplicity and thoroughness will interest all, whether beginners or experts.

**2/6, post free 2/9**

## RADIO PLAYS

by L. du GARDE PEACH

Millions of wireless listeners who have been thrilled by such wireless plays as "The Path of Glory" and "The Marie Celeste" can now have these and other plays in book form. An indispensable guide for all who would write plays for the microphone. No library is complete without these thrilling plays.

**2/6, post free 2/9**

## FINDING FOREIGN STATIONS

by R. W. HALLOWS

This book will be welcomed by all wireless enthusiasts. The number of people who possess wireless sets of requisite power and who fail to get foreign stations satisfactorily, is legion. This book will enable you to obtain the best possible results of which your set is capable.

**3/6, post free 3/9**

Obtainable from all Newsagents, Booksellers and Bookstalls, or at post free rates from

**GEORGE NEWNES LTD., 8-11, SOUTHAMPTON STREET, STRAND, LONDON, W.C.2**

# "PRACTICAL WIRELESS" DATA SHEET No. 2

## COILS AND COIL WINDING

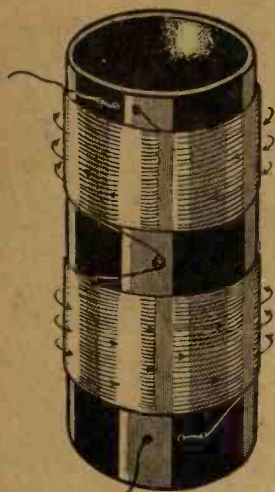

An Astatic Coil

An Astatic Coil is a coil wound in two sections, with each section in opposition. This method of winding is known as "Astatic," and the purpose of it is to reduce the size of the external field. The fields of each section neutralise each other and so it is possible to arrange two of these coils in fairly close proximity with employing metal screens. A small screw or other stud is inserted in the coil former at the central point, and when one half of the coil has been wound the wire is taken round the stud and the remainder of the winding concluded in the opposite direction.

### FINDING THE INDUCTANCE OF A COIL.

Tuning coils are stated to have a certain Inductance. The Unit of Inductance is the "Henry," and 1 Henry is the value of inductance which will cause a change of current of 1 amp. in 1 second upon the application of 1 volt. In wireless practice the tuning coils never have a value approaching a Henry and therefore a smaller value is chosen and this is one-millionth part of a Henry, or, in other words, a "microhenry." The formula for finding the inductance of a tuning coil (which has no metallic core) is:—

$$\text{Inductance} = \frac{4 \pi A N^2}{l} \times 10^9 \text{ henries}$$

where A = sectional area of the coil in sq. cms.

N = number of turns.

l = length of the coil in cms.

### ASTATIC COILS.

An Astatic Coil is a coil wound in two sections, with each section in opposition. This method of winding is known as "Astatic," and the purpose of it is to reduce the size of the external field. The fields of each section neutralise each other and so it is possible to arrange two of these

### SHORT-WAVE COILS.

Coils for the short wavelengths need the minimum of dielectric and therefore it is usual to use air-spaced coils for this purpose.

The coil illustrated is a good example of a short wave coil, in which the wire is of bare copper having a large cross-section (16 or 18 S.W.G.). This wire should be wound round a former slightly smaller in diameter than is required in the finished coil and the turns should be wound side by side. When the required number of turns has been laid on the wire is cut and released. It will spring out to the necessary size and the turns will automatically space themselves. Small strips of ebonite may be screwed or tied to keep the turns from shifting. The mounts for these coils should also be designed with a minimum of dielectric material.

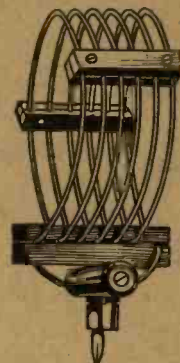

A Typical Short-Wave Coil

### URNS PER INCH

S.W.G.	Enamel.	Turns per inch.				S.W.G.
		S.S.C.	D.S.C.	S.S.C.	D.S.C.	
16	15	14	14	14	13	16
17	17	16	16	15	14	17
18	20	20	19	18	17	18
19	23	23	23	21	20	19
20	26	26	25	23	21	20
21	29	29	28	26	23	21
22	33	33	31	29	26	22
23	38	38	36	33	29	23
24	42	42	40	35	31	24
25	46	46	43	38	33	25
26	50	50	47	41	35	26
27	55	55	51	44	37	27
28	61	60	56	48	40	28
29	66	65	60	51	42	29
30	73	72	67	54	44	30
31	77	76	70	56	46	31
32	83	81	75	58	48	32
33	88	87	80	60	50	33
34	98	93	85	70	52	34
35	106	101	91	80	61	35
36	116	110	102	86	64	36
37	128	120	110	92	67	37
38	143	133	121	100	71	38
39	168	149	134	109	75	39
40	180	159	142	114	78	40

### MEDIUM WAVE COILS.—Inductance 200 microhenries.

Gauge of Wire.	No. of turns.	Diameter of former.	Length of winding
30 D.S.C.	102	1.25"	1.52"
30 D.S.C.	82	1.5"	1.22"
30 D.S.C.	68	1.75"	1.01"
30 D.S.C.	59	2.0"	0.88"
28 D.S.C.	57	2.25"	1.01"
28 D.S.C.	51	2.5"	0.91"
26 D.S.C.	45	3.0"	0.95"

### LONG WAVE COILS.—Inductance 2,100 microhenries.

Gauge of Wire.	Diameter of former.	No. of slots.	Turns per slot
36 enam.	1.0"	5	80
36 enam.	1.5"	3	81
36 D.S.C.	2.0"	3	65

### DUAL-RANGE COILS.

A modern coil wound to cover two wave-bands, and known as a "Dual-Range coil." The coil for the normal, or medium wave-band is wound in solenoid form on the upper part of the former, whilst the wire for the long wave winding is arranged in slots in the lower portion. The wire in the slots is simply piled up anyhow, as many as 90 turns sometimes being included in each slot. In the commonest form of dual-range coil the long-wave winding is short-circuited by a simple switch when using the normal winding. Tappings may be included for the aerial circuit, but these necessitate complicated switching devices.

### SOLENOID COILS

The simplest type of coil, known as the "Solenoid" is shown below. This consists of a cylindrical former with the wire wound on in the form of cotton or a cotton-reel. The most efficient winding has a diameter greater than the length. The principal defect of this type of coil is its large external field which necessitates a large baseboard in order that no metallic bodies or other coil windings may be brought within the field.

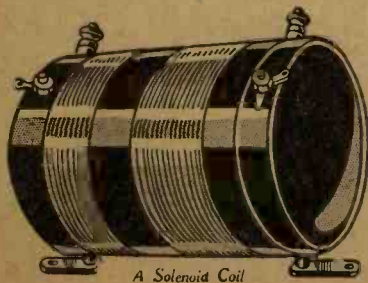

A Solenoid Coil

### FINDING THE WAVELENGTH COVERED BY A COIL.

The wavelengths to which a given coil will tune are determined by its inductance and the tuning condenser used with it. The minimum wavelength will be that of the coil alone (roughly) and the maximum wavelength will be that of the complete closed circuit, that is, the coil with the maximum capacity of the condenser in parallel. The formula for finding the wavelength of a closed circuit is:—

$$1.885 \sqrt{(\text{Capacity} \times \text{Inductance})}$$

where the capacity is in micro-microfarads and the inductance in microhenries. If the capacity is expressed in microfarads, then the first figure in the above formula becomes simply 1.885. It must be borne in mind that the addition of an aerial and earth to a coil affects its range.

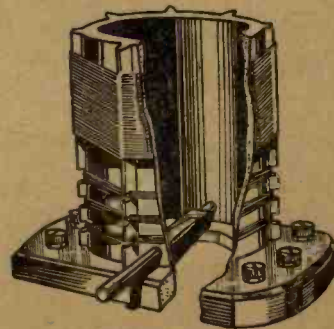

A Dual-Range Coil



# THIS PICK-UP DOES JUSTICE TO THE RECORD

A pick-up which gives the record its due and reproduces every subtle inflexion of harmony at its tone value. Such is the B.T.H. Pick-up, the choice of leading radiogram manufacturers and radio engineers; and the most widely used of any.

Your dealer will be pleased to demonstrate the various models in the B.T.H. range.

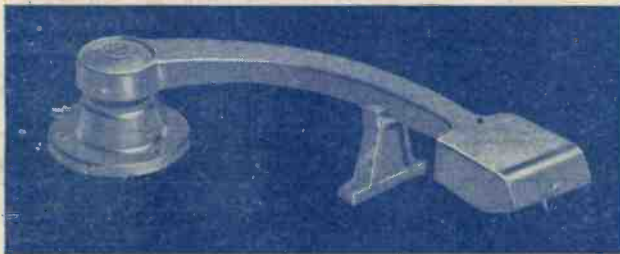

**B.T.H. MINOR PICK-UP** has been re-designed and improved and now includes a special volume control fitted in the base of the tone-arm pillar. This model is constructed in a one-piece moulding of B.T.H. "Fabrolite" and is recommended to those requiring a highly efficient but inexpensive pick-up. Price 25/-.

**B.T.H. SENIOR PICK-UP** complete with four adaptors to fit standard tone arms. Price 27/6.



**B.T.H. SENIOR PICK-UP (1933 model).** This has been completely re-designed and gives an even better response curve than hitherto. Free coupling of the head to the tone arm reduces pressure on records and facilitates needle changing. Price £2.2.0. (Complete with volume control).



## PICK-UP and Tone Arm

EDISWAN RADIO-100% BRITISH

THE EDISON SWAN ELECTRIC CO. LTD.



155 CHARING CROSS RD., LONDON, W.C.2  
W.201



**FREE INSIDE! DATA SHEET No. 3. RESISTANCES**

# Practical Wireless

**3<sup>D</sup>**

Published every Wednesday by  
**GEORGE NEWNES LTD.**

Vol. 1—No. 15  
DECEMBER 31st, 1932.

Registered at the G.P.O. as a Newspaper.

*Making A*  
**SUPER-HET  
CONVERTER**

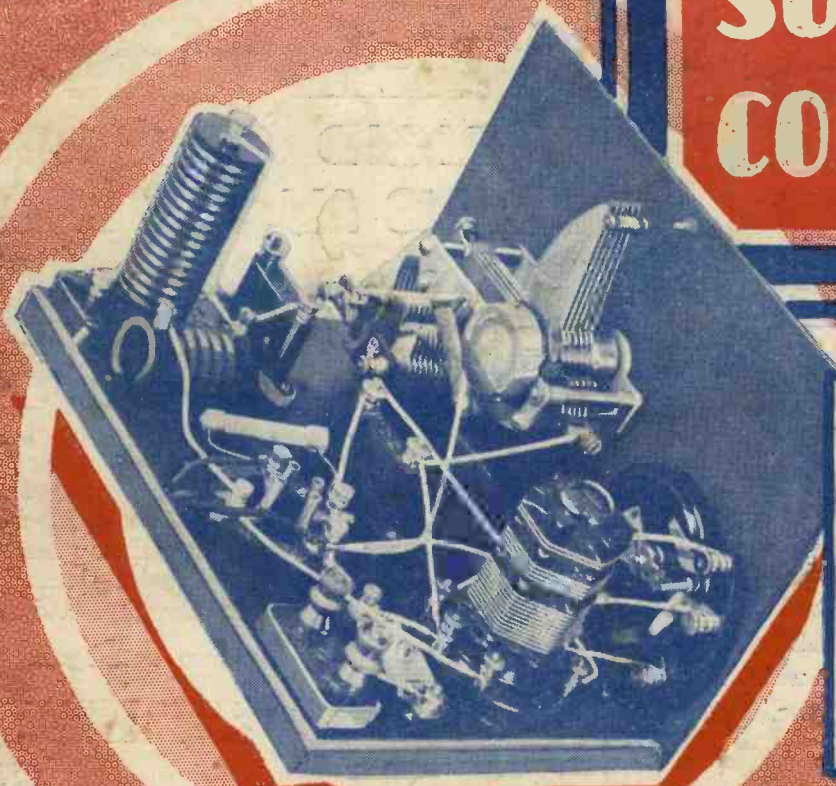

**SEND US YOUR  
WRINKLE  
AND  
WIN HALF-A-  
GUINEA**

*Whether it's bought  
Or whether it's built,  
Earth your Receiver  
By fitting a FILT!*

**GRAHAM FARISH FILT**  
**PERCOLATIVE CHEMICAL EARTH**

If you cannot readily obtain a FILT from your radio dealer order direct, post free, from sole manufacturers: **GRAHAM FARISH LTD.,** 201, Mason's Hill, Bromley, Kent.

**PRICE**  
**2/6**  
**COMPLETE**

Higher ampere-hour efficiency means  
**QUICKER CHARGING**  
**SLOWER DISCHARGING**  
**LONGER LIFE**



Type E.L.S.7. 60 a/h capacity. Price **12/6**



Type E.L.M.4. 45 a/h capacity. Price **8/-**



Type E.L.9. 80 a/h capacity. Price **12/3**

"Balanced Capacity," the new principle utilised in Ediswan Extra-life Accumulators, means higher ampere-hour efficiency. The special design of the positive and negative plates ensures complete electrical "balance" and reduces the possibility of "shedding" to an absolute minimum. In addition to their high electrical efficiency, these accumulators embody many mechanical refinements—British-made clear glass containers, moulded ebonite lids, screwed vents, non-corrodible and non-interchangeable connectors and metal carrier which fits neatly round the container.

# EDISWAN

**EXTRA-LIFE**

# ACCUMULATORS



THE EDISON SWAN ELECTRIC CO. LTD.  
 155 CHARING CROSS ROAD, LONDON, W.C.2 B.208

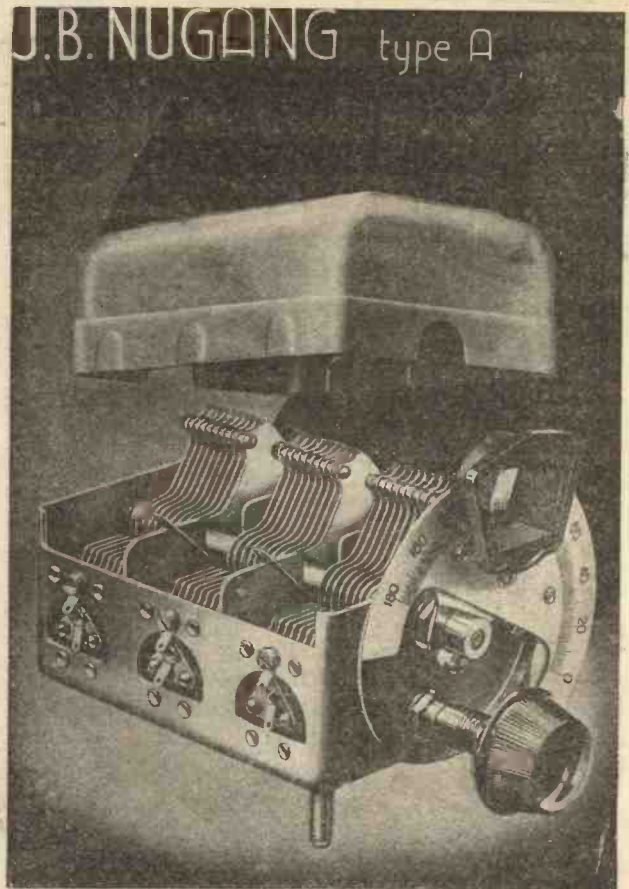

## A RIGID CHASSIS THAT IS ALL ONE PIECE

*Matched to within 1/2 of 1 per cent. + half a mmfd.*

So strong that there can never be the slightest distortion in use. NUGANG TYPE "A" is similar to the standard Nugang Model, but with the addition of a powerful Disc Drive. Easily fitted—only round holes to cut in receiver panel.

Trimmers to each stage operated by external starwheels. Vanes wide spaced and of heavy gauge. Special rotor bearings ensure *permanent accuracy* and give remarkably free movement. Capacity, .0005 mfd.

*Write for new catalogue.*



NUGANG TYPE "A"  
 Complete with Disc Drive.

Fully screened.	Semi-screened (without lid.)	
18/6	2-gang	16/6
27/-	3-gang	24/6
34/6	4-gang	31/6

## PRECISION INSTRUMENTS

Advt. of Jackson Brothers (London), Ltd., 72, St. Thomas' Street, London, S.E.1. Telephone: Hob 1837.

*a Gift Suggestion*  
**Amazing Selectivity**  
**— ALL stations clearly**  
**and without overlapping**



**AND NO  
 ATMOSPHERICS**

Improve your radio beyond all recognition! Hear all stations—even those you have never heard before—clearly and distinctly . . . with whatever degree of volume you please . . . without distortion of any kind and without annoying static noises. You can with a Cop. It is

**7 ACCESSORIES IN ONE**  
 —all combined in a well-made, super efficient aerial lead-in and automatic cut-out which—even during the worst of storms—will enable you and yours to listen in safety (backed by a £100 FREE insurance Policy against damage by lightning). What gift would be more appreciated by your radio friends. A Cop is just the thing you need, too! Get one TO-DAY—from your local Radio Dealer or post free, direct from the makers.

**PRESSLAND  
 AERIAL CONTROL**

CLIFFORD R. PRESSLAND  
 (SALES) LTD.,  
 84, Eden Street,  
 KINGSTON-ON-THAMES.

PRICE  
**2/6**

**COP**

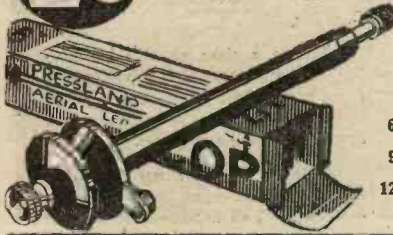

Prices:  
 6 in. 2/6  
 9 in. 3/-  
 12 in. 3/6

**£100  
 FREE  
 INSURANCE  
 AGAINST  
 LIGHTNING**

*Scientific*

**MORE STATIONS  
 LESS INTERFERENCE**

**WITH A PIX**

Because a PIX fixed in your aerial lead-in cuts out local and powerful stations and brings in loud and clear scores of foreign stations previously swamped or heterodyned. The PIX is the only gadget that will separate stations.



A PIX works equally well on a crystal, battery or all-mains set. Fix a PIX in your aerial and enjoy foreign concerts to-night.

No alteration to set. The PIX clip holds the PIX in position.

Send postal order or from your local dealer.  
**BRITISH PIX CO., LTD.,**  
 Department 360

113/28, SOUTHWARK ST., LONDON, S.E.1

**OVER 1,000,000 IN USE**

**2/-  
 2/9  
 with clip**

**COSTS ONLY**

**9/6**

**FOR ALL MAINS  
 OR BATTERY SETS**

Consists of Automatic Relay completely enclosed in Bakelite case, size 4 x 2½ x 2¼ ins. Simple to instal.

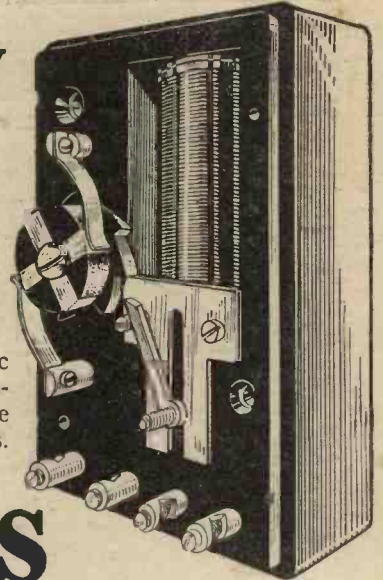

**WATES  
 Distance Switch**

Operating power merely a flash lamp battery controlled by any number of ordinary 'bell pushes.' Foolproof: no danger to set or person. Adds tremendously to the value of any set.

**GIVES  
 YOU  
 RADIO  
 ALL OVER  
 THE HOME**

**EXTRA  
 SPEAKERS  
 WHEREVER  
 YOU LIKE**

**SET  
 SWITCHED ON  
 OR OFF FROM  
 ANY ROOM**

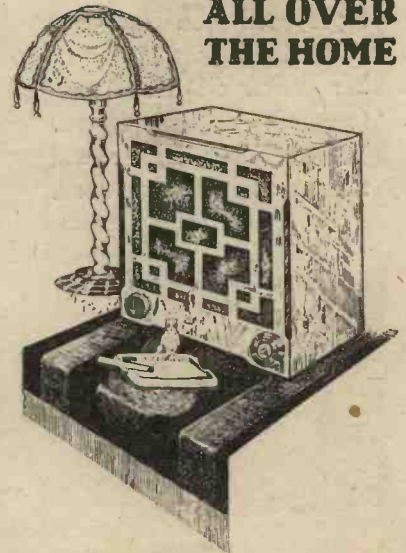

WATES  
 DISTANCE  
 SWITCH

Switching on and off from any or all extra Speakers without resource to main Set

Of Radio Dealers, Ironmongers, etc., with Simple Instructions  
 Send Postcard Now for folder "Radio & Comfort"

**WATES RADIO LTD**  
 184-188 SHAFTESBURY AVENUE LONDON W.C.2

".....now I have a set which gives **Selectivity,**  
**Volume** without distortion and **Tonal**  
**Qualities unsurpassed"**

Why be satisfied with indifferent wireless? Perhaps, unknown to you, yours is one of the thousands of Receivers that is being throttled by obsolete or worn-out valves. Like the writer of the letter here reproduced you can give your Set a new lease of life—better all-round performance—by fitting Cossor Valves. Your Dealer will tell you the types you need.

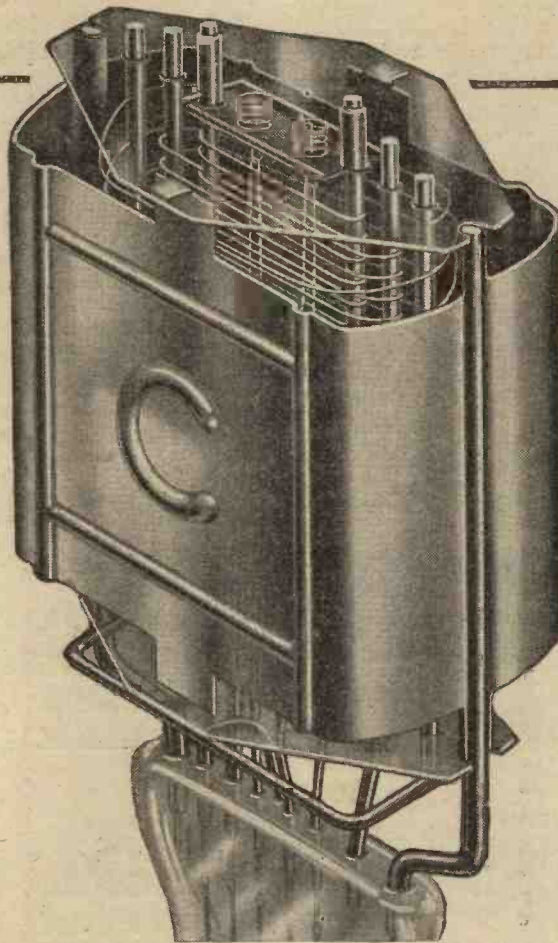

Chesterfield.

Dear Sirs,

I have a three years' old 3-valve Receiver (not a super set by any means) and, I can say, without fear of contradiction, that I never had such astounding results as when I fitted Cossor Valves.

I tried one of your Power Valves and the volume and rich, mellow reproduction were great. This improvement made me decide to replace the other two with Cossor and now I have a set which gives selectivity, volume without distortion, and tonal qualities unsurpassed.

Yours faithfully,

Sgd. \_\_\_\_\_

The original of the testimonial above reproduced may be inspected at our Head Office, Cossor House, Highbury Grove, London, N.2.

Send for a free copy of the Cossor Valve and Wireless Book—40 pages of interesting information including Radio Definitions—Useful Circuits—List of Stations, etc., etc. Use the Coupon.

# COSSOR VALVES

A. C. Cossor Ltd., Highbury Grove, London, N.2. Depots at Birmingham, Bristol, Glasgow, Leeds, Liverpool, Manchester, Newcastle, Sheffield, Belfast, Cardiff and Dublin.

To A. C. COSSOR LTD., Melody Department, Highbury Grove, London, N.2 Please send me, free of charge, a copy of the 40-page Cossor Valve and Wireless Book B.37.	Name _____	My usual Retailer is _____ Address _____
	Address _____	
	PRAC. 31, 12/32.	

**ANOTHER FREE DATA SHEET NEXT WEEK!**



# ROUND *the* WORLD of WIRELESS

**She Shall Have Music Wherever She Goes**  
**T**HE 1.20 p.m. L.N.E.R. express from King's Cross to Edinburgh, and the 2.5 p.m. express returning from Scotland to Town have both been equipped with radio-gramophones for the benefit of passengers during the run. Special records with descriptions of points of interest on the route are broadcast at the appropriate time, and during the intervals of the gramophone musical entertainments.

**To Further Increase Ether Congestion**  
**A**S the broadcasts of the new Prague transmitter are poorly received in certain parts of Czechoslovakia it is proposed to erect a relay station at Pilsen.

**A Radio Hotel de Luxe**  
**M**OST of the rooms of the Waldorf Astoria Hotel, New York, possess a small panel furnished with six knobs, five of which on being pressed will supply the occupier with different radio programmes from the main American studios. The sixth will be used for the reception of television broadcasts.

**Too Many High-power Stations**  
**S**INCE the 17 kW. Frankfurt-am-Main transmitter has been brought into operation on 259.3 m., listeners in that city complain that interference exists both with Hörby (Sweden) and London National. The latter programme creeps through and spoils the reception of the local entertainments. There is a possibility that Frankfurt may exchange its channel with Berlin.

**Seeing on the Low Waves**  
**B**.B.C. experimental television broadcasts are now being carried out on Wednesdays and Fridays between 3 and 5 p.m.; the exact wavelength is 7.3 m. The transmissions are made from Broadcasting House.

**Fighting the Radio Pirate**  
**I**N Canada dealers in receiving sets or components may not effect any sales unless the purchaser can show his or her listening licence. Heavy fines are inflicted if this law is not enforced.

**Only Small Fry—But Well Heard**  
**A** GROUP of radio amateurs have installed a 250 watt station at Chatellaneu, near Charleroy (Belgium). It operates

every evening on 215.3 metres, and reception of its broadcasts has been reported from Great Britain and Central Europe.

**The Land of Depressions**  
**U**TVARP Reykjavik is the call you may pick up, on 1,200 metres, on some favourable nights. It is that of Iceland's broadcasting station. The announcer, Sigrid Oegmunds, a young woman nineteen years old, speaks German, French, and English, in addition to the Scandinavian languages. Icelandic local time is one hour behind that indicated by our clocks. On Saturday nights the studio may be heard closing down at 1 a.m. G.M.T. with an old Icelandic hymn.

8 a.m. G.M.T. on 31.28 metres; its power is 12 kW. As an interval and concluding signal, the song of the Lyre Bird (Kookaburra) has been adopted: for this special purpose it was recorded on sound-film in Sherwood Forest, near Melbourne.

**Radio Developments in Norway**  
**N**OTWITHSTANDING the power of the Oslo station, Norway has not been covered by its broadcasts. The authorities propose to spend during 1933-4 a million kronen (about £50,000) on the installation of 2 kilowatt transmitters at Stavanger, Tromsø, Arendal, Kristiansund, Haugesund, and Kirken. Bergen, whose 1 kW. station has been in operation for several years, will be endowed with a 20 kW. transmitter.

**Super Power Station for Berlin**  
**W**ORK has already been started on the buildings at the Tegel Military Shooting Ranges near the German capital to house the 60 kW. station destined to replace the Witzleben transmitter. It is expected that the new station will be ready by the early summer of 1933.

**A Note for D.X. Fans**  
**B**BROADCASTS from WKAQ, San Juan, the new 1 kW. transmitter operated by the Radio Corporation of Porto Rico, have been heard on several occasions during the past fortnight. The station works on 241.8 metres (1,240 kilocycles), and its concerts are best tuned in between midnight and 2 a.m. G.M.T. The station is already on the air at 6 p.m. G.M.T.

**A Radio Fanatic**  
**I**T is reported that Harry Frank Wilcox, a citizen of New York (U.S.A.) inserted in his will a clause to the effect that his pet eight "toob" radio was to be buried with him in the family vault: a sum of money was left to defray the expenses of keeping it in working order.

**Sending Announcers to School**  
**T**HE Italian broadcasting authorities have installed a special school at Florence for the training of pupils destined to become studio announcers. At this institute they are taught to speak perfect Italian and also receive tuition in foreign languages.

### The Cost of Radio Advertising

**A**LTHOUGH permission to work the new 200 kilowatt Radio Luxembourg has not yet been obtained, the owners are canvassing the Continent with a view to concluding contracts for publicity over the ether. According to a report received from Holland, the station may be released at the cost of some nine thousand French francs per hour—roughly, at to-day's rate of exchange, £110. In addition, in the case of sponsored concerts, the fees of the artists contributing to the programme must also be paid.

**Listening to Down Under**  
**R**EGULAR transmissions may be heard from VK2ME, Sydney (N.S.W.), every Sunday morning between 6 and

\*\*\*\*\*  
 HAVE YOU YET  
 RESERVED YOUR  
 SELF-BINDER  
 for our  
 DATA SHEETS?  
 SEE PAGE 727  
 \*\*\*\*\*

# ROUND *the* WORLD of WIRELESS (Continued)

## Will the Eiffel Tower Close Down ?

FROM Paris comes the news that negotiations have been opened between the Posts and Telegraphs administration and the *Compagnie Française de Radiophonie* with a view to the former taking over the new Radio-Paris transmitter. Should the scheme mature, the broadcasts from the Eiffel Tower would be suspended, and its wavelength would be used by the 200 kilowatt station now ready to operate at Luxembourg. The latter station, in this event, would start up without delay and would take over the sponsored concerts hitherto transmitted through Radio-Paris. For some time the authorities have realized that the Eiffel Tower is not suited to the broadcast of wireless entertainments, and it would thus be permitted to revert to its official duties.

## Similar Interval Signals

WILNO (Poland), Ljubljana (Jugoslavia), and Lisbon (Portugal) have each in turn adopted a cuckoo call as interval signal between programme items. Fortunately, they broadcast on totally different channels of the wave-band.

## Cape Town Calling !

THE Marconi Company will shortly erect at Milher-ton, near Cape Town, a 10 kilowatt transmitter for the African Broadcasting Company, to replace the smaller station now supplying the wireless entertainments; the wavelength of 370 metres which is at present being used having proved favourable will remain unaltered.

## What the U.S.A. Stations are Doing

IN 1931 the National Broadcasting Company of America relayed 147 programmes from foreign studios for the benefit of its listeners, and during the past year this number has been exceeded. In addition regular transmissions from Europe have been taken at regular intervals by the Columbia network.

## Another Wavelength Conference

AS a result of the decisions taken at Madrid last month the International Union of Broadcasting Stations (U.I.R.) will probably meet at Berne (Switzerland) during June, 1933, to discuss a further plan for the allotment of wavelengths. From the point of view of European listeners the Madrid Conference appears to have been a complete failure.

## K. Raymond Again

ONE of the earliest firms in the radio industry, Messrs. K. Raymond are again entering the field. A new department has been formed which supplies any up-to-date set, and is willing to take an old set in part exchange, making a very liberal allowance for it. This will enable all listeners with old sets to become really up to date at small expense. We are glad to see this name once again, and are pleased to bring this notice to the attention of our readers.

## INTERESTING and TOPICAL PARAGRAPHS

### The New Leeds Studio

I WAS looking over the new B.B.C. headquarters in Leeds the other day and was very favourably impressed by their appearance. The architectural design is excellent and the whole place has a most palatial appearance. There is a very large studio, measuring about 50ft. by 40ft. and nearly 30ft. high, or about the same size as that at the new Manchester H.Q. It is appreciably larger than any of those in the old Savoy Hill buildings. I was informed that the Leeds buildings will be

## Nottingham

IT is understood that the Nottingham studio, which closed down when the North Regional came into being, is shortly to be renovated and reopened. This will be good news for Nottingham and district listeners, who will expect to hear more of their local talent.

## S.-W. Programme to be Relayed

READERS will be pleased to know that the Christmas Day short-wave transmissions to the Colonies will also be relayed through the longer wave B.B.C. stations. Excellent programmes have been arranged and, although definite arrangements have not yet been made, it is hoped that H.M. the King will broadcast Christmas greetings.

## Seventeen and a Half Hours Transmissions

AS mentioned in these columns before, the S.-W. Colonial broadcasting station will definitely commence operations early this month. The transmissions will start at 9.30 a.m., with a two-hour programme to Australasia, and then, after an interval of three hours, the Indian programme will run from 2.30 to 4.30 p.m. At 6 p.m. another two-hour period will be devoted to Africa; from 8.30 to 10.30 p.m. the West African transmission will be sent out, and, lastly, the Canadian programme will run from 1 a.m. to 3 a.m. (Tuesday morning). All times are G.M.T., of course.

## Breslau in France

I HEAR that French listeners are complaining of interference with their popular *Poste Parisien* transmissions on 328.2 metres by the new 60-kilowatt German broadcaster at Breslau, which works on 325 metres. Apparently the latter station is received at greater strength in France than are most of the French stations.

## Poste Parisien

SINCE the recent increase of power to 60 kW. *Poste Parisien* has been coming in at wonderful strength. I listened to the running commentary of the first Australian Test Match broadcast from this station from 6.30 to 8.30 on the morning of December 2nd, and it was surprisingly good. Despite the fact that the Australian commentator's remarks were sent over miles of telephone lines and thousands of miles of "ether," they were as clear as if he had been in the studio. Up to 7.30 a.m. the transmission was perfectly steady, but as daylight approached a certain amount of fading became noticeable, although signal strength generally was practically unchanged.

## Another European Station

A NEW station is shortly to take the air. This time it is in Greece, and it will be called *Radio-Thessalonik*. The wavelength will be about the 270-metre mark, but there are as yet no details available regarding its power.—JACE.

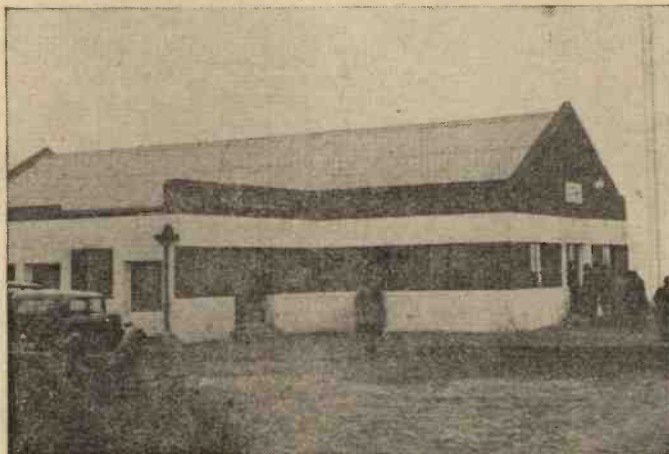

INSPECTION OF NEW EMPIRE TRANSMITTING STATION AT DAVENTRY.

The new Empire Transmitting Station which has been built at Daventry, for the purpose of transmitting programmes to all parts of the Empire.

ready for use by the New Year, and it is hoped to make full use of the recognized Yorkshire talent.

## SOLVE THIS!

### Problem No. 15

Having a rather good Moving Coil Speaker of the low resistance type, Jones decided he would like to try Push-Pull and see if it was an improvement on his present arrangement. He therefore obtained two matched valves and a centre tapped output choke. The anodes were joined to the ends of the choke, with the tapping to H.T. positive. The two anodes were also joined to the ends of the speech coil of the speaker. Results were terrible, signals being practically inaudible. What was the reason? Three books will be awarded for the first three correct solutions opened. Mark envelopes Problem No. 15, and send to the Editor, PRACTICAL WIRELESS, Geo. Newnes, Ltd., 8-11, Southampton Street, Strand, London, W.C.2, to reach us not later than 2nd Jan., 1933.

### SOLUTION TO PROBLEM No. 14

By twisting the Aerial and Earth lead together (by adopting lighting flex) Johnson was by-passing all his signals to earth through the capacity formed by the twisted wire.

The following three readers receive books in connection with Problem No. 15:—  
J. H. Davies, Esq., Bodaros, Halkyn Road, Flint, N. Wales; N. Snewin, Esq., 10, Sinclair Road, London, W.14; N. Clayton, Esq., 53, Senhouse Street, Maryport, Cumb.

# SAFEGUARDING *the* SET

Some Practical Points on Fitting Fuses for Protecting Certain Parts of a Receiver.

By GILBERT E. TWINING

ACCIDENTS happen in the best regulated sets, and they should be definitely guarded against. Serious damage may be done costing several pounds by inadvertently making wrong connections, or by working inside the set when it is switched on. If any metal tool, such as a screwdriver, is dropped into the interior of the set it may cause a short-circuit and bridge across the high-tension current to the low-tension circuit and thus burn out the filaments of the valves and harm some other component.

The ordinary house lighting supply is divided into several circuits, each circuit being protected by a fuse so that the current cannot exceed the safety point without the fuse blowing or melting. When a short does occur or for any other reason the fuse burns out, it is a simple matter to replace it with another length of 5 ampere fuse wire. From this it can be understood that the different circuits and components in the wireless set should be protected in exactly the same way. Wireless currents are so very minute, however, that any normal type of fuse would be useless, for in house lighting the current is calculated in amperes, whilst in wireless practice it is calculated in milliamperes, which is one-thousandth part of an ampere; because of this, fuses are required which will blow at a very much lower value.

The filament of a 2-volt valve is so constructed that the current from a 2-volt battery heats it to the correct temperature. If the voltage of the current is excessive the filament will get so hot that it will actually melt, and the valve will then, of course, be useless. To prevent this excessive overheating a fuse is inserted, and the most

common position for it is from the high-tension negative terminal across to the low-tension negative terminal; this will stop any high-tension current from overloading the valve filament through a short-circuit. The fuse is shown in position in Fig. 1.

### The Function of a Fuse

A fuse is a device which; when the normal current that it passes is exceeded, breaks down and in so doing prevents the components in the set from burning out.

There are several very good inexpensive fuses on the market at the present time and types very similar to flash-lamp bulbs have been developed and operate on as little as 60 milliamperes; these blow at about 100 milliamps. They can be obtained up to values in the neighbour-

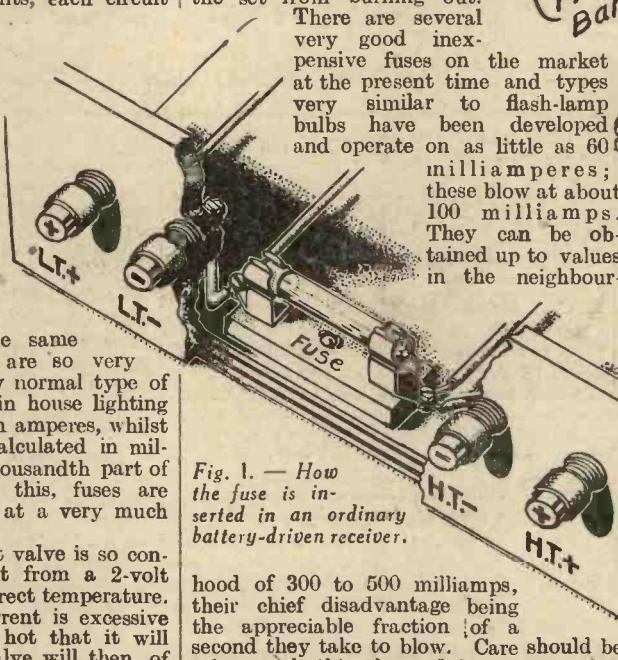

Fig. 1. — How the fuse is inserted in an ordinary battery-driven receiver.

hood of 300 to 500 milliamps, their chief disadvantage being the appreciable fraction of a second they take to blow. Care should be taken with this class of fuse to see that when replacements are made they are of the correct value. Another very good fuse is the gold film fuse, which is a very thin layer of gold mounted on a thin strip of glass. At normal currents it has excellent conductivity and when it does break down its action is very quick.

Sometimes a fuse will glow or even burn out when the set is first switched on and this is accounted for by the fact that the set has probably several 1 or 2 microfarad condensers in its make-up and the action of switching causes a momentarily larger current to flow which charges these condensers sufficiently high to exceed the rating of the fuse. In this case a fuse of a little greater capacity should be fitted of, say, 100 milliamps. These fuses, which have to carry very small currents, have an appreciable resistance

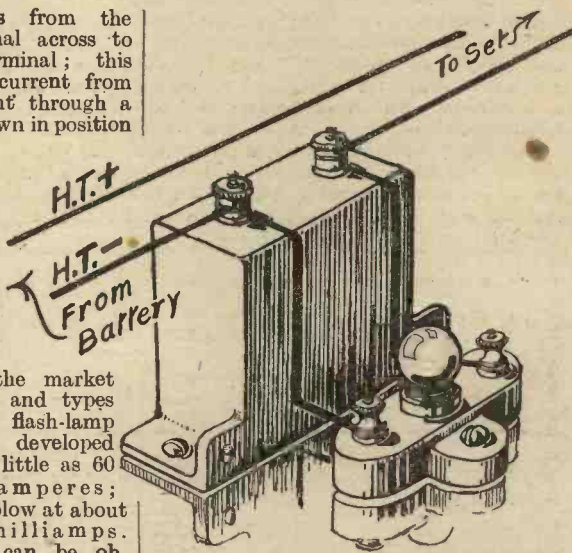

Fig. 3. — A pictorial representation of the arrangement shown in Fig. 2.

and when such fuse is connected in the common negative lead, battery coupling may be introduced; this can be overcome by shunting the fuse with a 1 microfarad condenser as shown in Figs. 2 and 3.

When deriving high-tension from the mains it is advisable to insert a fuse in each lead from the supply to the input side of the mains transformer of the set; these fuses, however, must be capable of carrying a larger current than the ordinary battery fuse, it is not sufficient to fit fuses rated to carry the normal current and blowing at twice this amount, for the reason that at the time of switching on the surge of current rises to, perhaps, three or four times this value, therefore the fuses must be obtained to stand up to this extra surge and to blow at three to four times the normal current.

In fitting fuses in a mains radiogram, where the turntable is operated also from

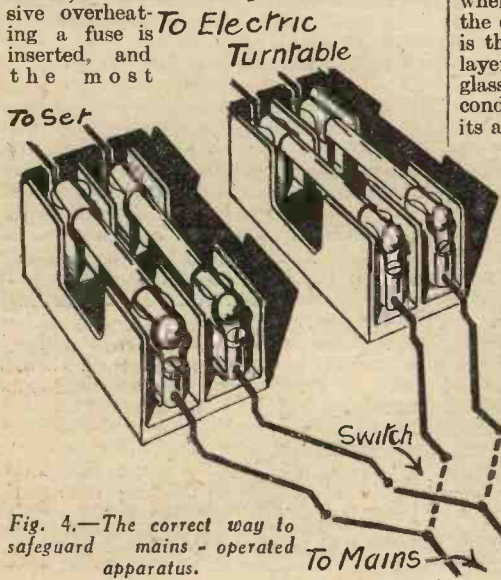

Fig. 4. — The correct way to safeguard mains-operated apparatus.

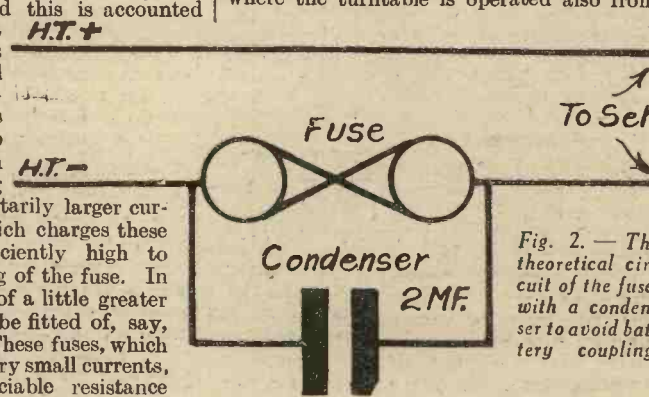

Fig. 2. — The theoretical circuit of the fuse, with a condenser to avoid battery coupling.

the mains, it is advisable to incorporate two sets of fuses after the mains switch, that is to say, one in each lead going to the set and one in each lead going to the motor, see Fig. 4, care being taken to keep the motor leads right away from the low-frequency side of the set, otherwise induction will probably take place and produce a very bad mains hum when the gramophone part of the set is being used. When a fuse does blow it is very necessary to locate the fault before inserting a new one; look for frayed flex, loose or broken connections, or even short pieces of connecting wire left inside when the set was being built, for these may have moved and so be causing a short-circuit. If the baseboard of the set is covered with aluminium foil, or sheet, it is advisable to slip under the valve holders a disc of cardboard slightly larger than the

diameter of the holder; this will prevent any chance of the valve pins projecting through the holder and touching the foil, or if the foil is very thin it will also prevent



it from buckling up under the holder and touching the screws which hold the sockets into which the valve pins fit. Care should be taken when not using the soldering tags on components, the terminals of which are placed close to the metal foil, that the tags do not become bent downwards so that they make contact with the foil, thus earthing the connection. Such a tag is shown in Fig. 5. It is better to remove them, if possible, before building up or cut them off short with an old pair of scissors, if no cutting pliers are handy. The writer had a similar experience of this kind when called in to test a set some time ago; every conceivable test had been made until it was noticed that a soldering tag which was almost out of sight was earthing on to the metal base. When this was corrected the set worked perfectly.

## WIRELESS IS KILLING BOREDOM

By Colonel Sir Arthur Holbrook, K.B.E.

MIRACLES cease to be miracles by the process of repetition. And every miracle finds critics just as soon as its magic is forgotten. To this rule radio is no exception. The first programmes, imperfect but now endowed with all the glamour with which the present endows the past, were hailed with unconcealed delight and little or no criticism. They were accounted wonderful by the fact of their very existence. This phase passed.

Radio has now arrived at the stage where its critics, in public, at any rate, are more vociferous than its defenders. But is it not time that we took a calmer, a more reasoned view, of the whole situation; time that we recognized how wireless, with all its imperfections, has killed boredom—the monster which threatened to make life a sour and tasteless thing until it was banished by radio? The specialist in any particular sphere, whether it be music, drama, talks, vaudeville, or sport, can, no doubt, find much at which he is righteously indignant in the way his own pet subject is treated by those in authority at Broadcasting House. And in letters to the Press, supported by every other means at his command, he airs his grievances with little or no difficulty, for most newspapers, apart from those specifically devoted to radio, are ever ready to give prominence to any snack at broadcasting as at present constituted. Judging by most of the printed comments of this nature, a traveller from another planet might be excused the thought that there is nothing right about the fare which emanates nightly from millions of loudspeakers.

It is easy to criticize radio, particularly if you have a bee in your bonnet, but devilishly hard to be constructive where the tastes of millions of listeners are concerned. Which probably explains why there are so many self-appointed radio critics. At the other end of the scale, equally misguided, are those fanatics who make grandiloquent and unprovable assertions as to what radio is doing for this, or that, or the other; the people who plead that radio is assuring the future peace of the world, as though a few unintelligible words of German or Italian or French heard through a loud-speaker

make any appreciable difference in the fundamental outlook of the majority of listeners; the people who would have us believe that a few years of radio will be equivalent, as far as turning us all into highbrows is concerned, to a course at one of the older universities; and so on!

### Radio's Great Achievement

All these specialist critics and extravagant claimants only confuse the issue, and blind us to the real significance of radio—the fact that it is slowly but surely killing boredom. This is an achievement which excuses its minor sins a thousand times over. Do you seriously doubt that radio is doing this thing? If so, consider for a moment the way family life was drifting just before its advent. The optimist would portray the various members of the average family as spending their leisure mainly outside the home. He might draw your attention to the fact that father and mother were ardent theatre-goers, Johnny a movie fan, Bill a young man devoted to sport, and Milly a confirmed cyclist. He might try to convince you that most of their leisure time was spent doing these various things; that they were rarely at home. Do not believe him. The fact is, of course, that for financial and other reasons, but mainly because they could not afford to do anything else, father and mother, Johnny, Bill, and Milly were forced to spend a great deal of their time sitting at home. The excursions were the "high spots"; sitting at home the everyday necessity.

On the whole they were bored with each other, sometimes more than others, but on the whole, bored. They each wanted to do different things, which resulted in their getting into each other's way, and they had little to say to each other beyond commonplaces, simply because they were all at different stages of development and lacked a unifying influence. They had the gramophone, of course, but here again expense limited the scope of this instrument. They were friendly to each other, amiable enough, but fundamentally they were bored.

In those days boredom stalked within the four walls of the average suburban home. Then as they say in the film cap-

tions, "Came the wireless." And very steadily—so steadily that some of us have hardly noticed—wireless has banished that boredom to a place whence it cannot return unless civilization perished in some world cataclysm, and with it radio. Father and mother, Johnny, Bill, and Milly have been provided with a sociable pursuit in which they can all participate. Wireless has given them a common interest, a sociable home pastime which they can share together, at the same time.

### An Ever-Recurring Pastime

Please note this very carefully. Novel reading is a pastime in which all the members of a family can join, but it is a solitary business. Two people cannot, or very seldom do, read the same book at the same time. When you are in the middle of a marvellous novel your one aim is to get someone else to read it and share your pleasure, but by the time you have finished and they are half-way through, most of your first enthusiasm has evaporated. Wireless is the one ever-recurring, inexpensive pastime which the whole family can enjoy as a single unit.

Family boredom dies when two or more members of the family share a common pursuit, even if they do not agree about its worth. It gives them ready-made topics for conversation, widens their horizon, quickens their imagination, rouses their interest, sets them arguing with each other. The result is that in the intervals between the business of getting a living and the occasions on which they take their pleasures outside the home as separate individuals, they are not bored—but, on the contrary, stimulated.

Wireless is killing boredom, and this is an achievement besides which all its little sins of omission or commission are as naught. And if it is an achievement to have banished boredom where the members of families are concerned, what praise is high enough for it in the case of the solitary listeners in their bed-sitting rooms, the invalids cut off from the outside world, the blind? For such as these it has banished not boredom, but something very like Hell itself.



# DISTANT CONTROL OF WIRELESS RECEIVERS

IN a previous article which appeared in PRACTICAL WIRELESS dated December 24th, 1932, I dealt at length with the many advantages associated with the wiring of different rooms in the home so that the loud-speaker could be used although remote from the set. No doubt many readers have already taken advantage of the suggestions made, but, as I have stated once before in these columns, it is a law of Nature that we never have an advantage without an accompanying disadvantage. Fortunately, in this case the disadvantage (a dual one) does not outweigh the advantages attached to loud-speaker extensions, and, furthermore, it is possible to counter one of the disadvantages in one or two simple ways. As far as the actual tuning of the set is concerned, this cannot yet be



rest lightly on the contact wheel. Around the plunger, which is mounted vertically, is a spool of wire or solenoid with a central opening into which the plunger can pass without undue friction. When a current of electricity is passed through the spool of wire the plunger is drawn up and the pawl engages with one tooth of the contact wheel,

**H. J. BARTON CHAPPLE,**  
Wh. Sch., B.Sc. (Hons.), A.C.G.I.,  
D.I.C., A.M.I.E.E.

your loud-speaker extension scheme a method whereby the set can be "remote controlled," as far as switching on and off is concerned.

### A New Distance Switch

Fortunately there are several simple ways of doing this, but I shall content myself with describing one or two. The first involves the use of a new and ingenious switch which has just been placed on the market by Wates Radio Ltd. Its very simplicity is its greatest recommendation, and I can well imagine readers saying, "Why hasn't it been thought of before?" It is called a distance switch, and is shown in an accompanying illustration and also diagrammatically in Fig. 1. As will be seen, it has only three moving parts, consisting of a toothed contact wheel having four contacts and four insulated sections, a pawl or lever, and a soft iron plunger to which the pawl is attached. Two spring contact arms

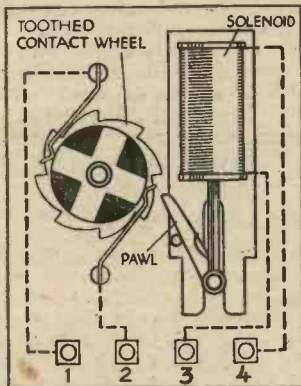

Fig. 1.—Diagram showing the elements of the Wates Remote Control.

carried out at a distance without very elaborate apparatus; but as a general rule this does not cause inconvenience. In the average home the set is often left tuned to one station for hours at a stretch, or, alternatively, altered only once or twice in the course of an evening. With an extension point within handy reach of the set, therefore, this does not involve much trouble.

What is objected to is the necessity for having to actually handle the set in order to switch it on or off at the beginning or end of the programme listened to. Often cases arise when wireless reception is desired in the bedroom, and it is a chilly job coming downstairs to switch off at this time of the year. Of course, the loud-speaker can be disconnected; but this is not only wasteful from the point of view of H.T. and L.T. consumption, but, if the speaker is connected direct in the anode circuit of the output valve, it is damaging to the valve to break the filament circuit and yet retain the grid bias on, and in the case of the pentode valve, leave the screen volts on as well. It is therefore advisable to include with

causing it to move through  $\frac{1}{4}$ th of a turn. When the circuit is broken and the current ceases, the plunger falls back by gravity, and is ready to turn the wheel through another  $\frac{1}{4}$ th turn on the next upward movement. Only a momentary current is required, as the action of the switch is very rapid. Thus, if the coil is connected to a bell-push

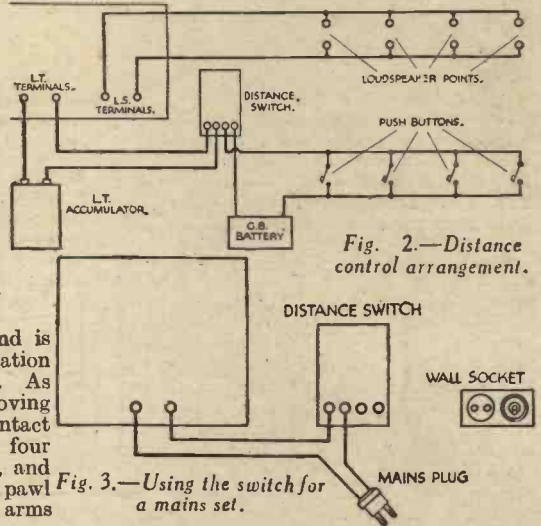

Fig. 2.—Distance control arrangement.

Fig. 3.—Using the switch for a mains set.

and battery, one pressure on the push turns the wheel  $\frac{1}{4}$ th turn, making a contact between the two springs, and the next pressure turns the wheel through another  $\frac{1}{4}$ th turn, thereby bringing the insulated sections under the springs and breaking the contact. The springs and wheel are thoroughly insulated from the rest of the mechanism, and may be safely connected in the electric-light mains lead to a wireless set.

In the diagram of Fig. 1 the terminals marked 1 and 2 should be taken to control the L.T. or mains power supply to the set, while 3 and 4 go to the bell-push and battery. Now for the method of fitting up the distance control arrangements—Fig. 2. Mount the switch vertically either inside the set cabinet or close to it, and, assuming for the moment that the set derives its L.T. and H.T. from accumulators and batteries, join terminals 3 and 4 in series with one of the leads between the set and the accumulator—the makers of the switch recommend the negative lead. Take a lead from terminal 4 to one pole of a flash-lamp battery (if the run of wiring to the distant point or points is more than twenty yards it may be necessary to use



The ingenious Wates Remote Control.

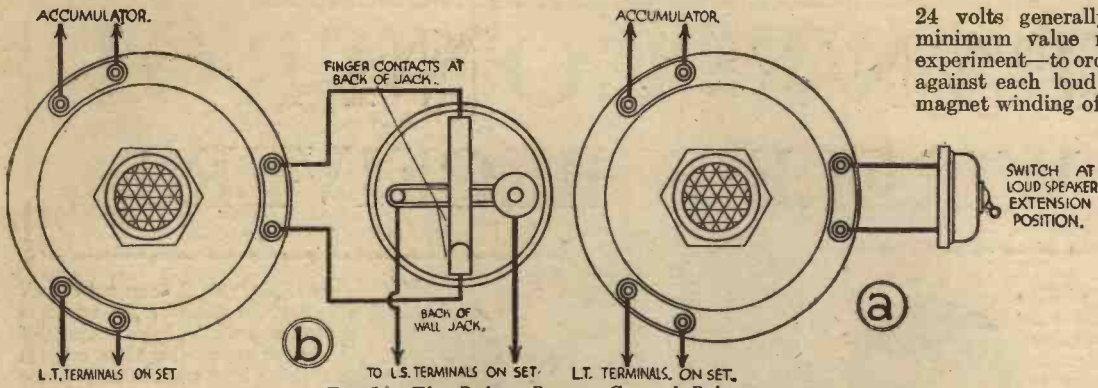

Fig. 5.—The Bulgin Remote Control Relay.

two flash-lamp batteries in series, or alternatively use a 9 volt G.B. battery). Finally, take a twin lead, join one end of one wire to terminal 3 and the other wire to the remaining pole of the flash-lamp battery. Run this lead to a convenient point in every room where distance control is desired—shown theoretically in Fig. 2. Join a push-button switch across the twin lead at each point and, assuming that a parallel extension of loud-speakers has already been effected, the arrangement shown in Fig. 2 will result.

**How the Switching Arrangement Works**

Obviously, one dual bell-push and speaker position will be adjacent to the set and the other points in rooms as desired. The switch on the set must be left on, and, if we imagine the distance switch is in the "break" position, a depression of any of the push-button switches will switch on the set. If by chance any one else should now push their switch button the set will be rendered inoperative, and the button has to be pushed again to energize the set.

When the family—assumed situated in different rooms of the house—is retiring for the night the following order of things will take place. Room A wants to finish, so depresses the push button in the room, but leaves the loud-speaker connected. A moment or two afterwards the loud-speaker comes to life again, indicating that those people in the other rooms are still listening in and have operated their own push button to switch on. The original party in room A must therefore disconnect their speaker if they do not want to listen. This process is followed by each room in turn until the last party switches off. If silence is maintained, they know that no one else is listening to the programme, and they can retire without touching their own loud-speaker, secure in the knowledge that the set has been safely switched off.

The scheme is a very simple one, and can be thoroughly recommended. For a mains-driven set the same distance switch will do, it being inserted in series with one mains lead, as shown in Fig. 3. For sets worked from an eliminator and L.T. battery a special switch—model B—must be used, as this particular one will control the two circuits simultaneously; that is, both mains and L.T. In the illustration a small board has been fitted up complete with switch, bell-push, flash-lamp battery and mains feed to illustrate the working of the switch, all the wiring having been carried out behind the board.

**Relay Switching**

Another form of distant control apparatus is that marketed by A. F. Bulgin and

Co., Ltd. This consists of a relay located near the wireless set, and on closing a switch situated at any loud-speaker position the relay closes, and this in turn switches on the filaments. This is indicated in Fig. 5A, and if the house is already wired up for loud-speaker extensions as described in my previous article, then it is only necessary to run a pair of leads to each switch position and add the relay. When the set is in operation a warning glow is reflected by the ruby indicator on the relay, and this not only shows that it is operative, but limits the current flow necessary to operate the device.

Another way of carrying out the same operation is to include what is called a Bulgin remote control wall jack at each loud-speaker position. This jack, in addition to the parallel type contacts employed for the loud-speaker extension, has

24 volts generally is suitable, but the minimum value must be found out by experiment—to ordinary bell pushes located against each loud-speaker position. The magnet winding of a relay, preferably one of the sensitive high-resistance type, such as a Siemens or Weston, is now joined between the H.T.—terminal of the battery and the L.T.—terminal of the accumulator. Then the movable contact arm is taken to the usual negative filament connection on the set, the positive lead from the accumulator going direct to the set.

When it is desired to listen to the broadcast programme, connect the loud-speaker, depress the bell-push and maintain contact. Current will flow immediately through the relay coils, and the movable "tongue" closes on its contact. The closing of the tongue now establishes the filament circuit, the valves are rendered operative and current at once flows through the output terminals via the loud-speaker, H.T. battery and relay. Once this current has been established the bell-push can be released, for the relay tongue will be held in contact with its stud. When any of the positions wish to finish listening in, the loud-speaker is disconnected, and when the last person has done this the anode current circuit is broken and the relay "opens," switching off immediately the filaments of the set at the same time.

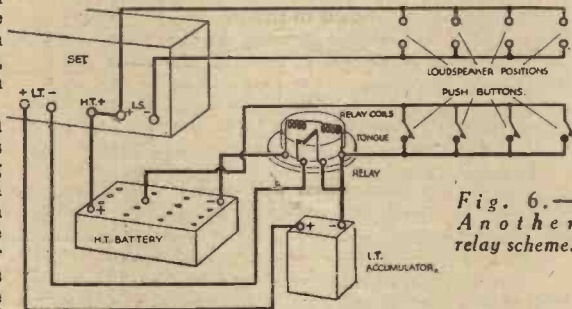

Fig. 6.—Another relay scheme.

**Another Relay Controlled Switching Device**

In conclusion, one other scheme will be described. This is shown in Fig. 7. At each loud-speaker position is installed a single filament control jack, while a four-core cable makes connection as indicated. A relay is wired up as drawn in the diagram, and on inserting a loud-speaker plug in any one position, current will flow from the L.T. accumulator through the relay coil. This attracts the relay tongue or contact, and the L.T. supply to the set is at once established.

It does not matter how many speakers are working on the circuit, but it will be noticed that the last loud-speaker plug to be withdrawn breaks the relay coil circuit.

A commercial form of this scheme is marketed as the Lotus Remote Control, and in some tests I carried out with the apparatus I found that the relay current consumption was only 20 milliamperes with a 2-volt accumulator.

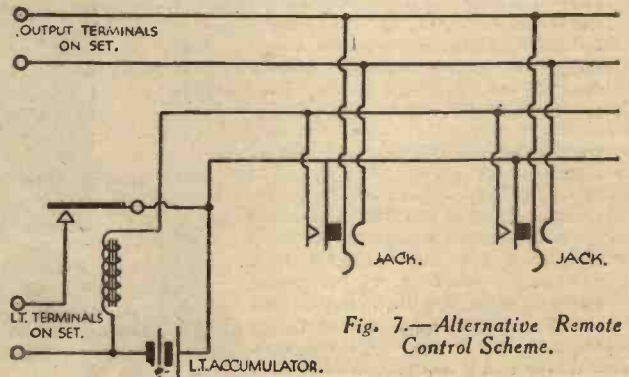

Fig. 7.—Alternative Remote Control Scheme.

a second finger contact which is closed by the pressure of the plug tip when inserted into the jack socket. The underside of the finger is insulated so that there is no electrical contact with the plug tip, only mechanical. The arrangement for this is shown in Fig. 5B, while an accompanying illustration depicts the special combined relay and indicating control, together with samples of the type of jack just described. Speaking of relays reminds me of another method which has been used to advantage by some people who have installed remote or distance control. It is illustrated in pictorial fashion in Fig. 6. First of all, it will be assumed that the loud-speaker points are ready wired up for parallel working as shown. Another pair of wires is run from the L.T.—terminal of the accumulator and a positive tapping on the H.T. battery—somewhere in the neighbourhood of

# A SHORT-WAVE SUPER-HETERODYNE CONVERTER

Some Further Details Concerning the Converter which was Described on page 689 of last week's issue.

IT was pointed out last week that the tuning control of the normal receiver, with which this Converter is employed, must be set to a tuning point on the long wave-band. This latter point is very important, and the actual construction of the receiver will govern the best wavelength to which it must be tuned. Generally speaking, a wavelength between 1,000 and 2,000 metres will be found suitable, and a certain amount of time should be spent in trying the different

## LIST OF COMPONENTS:

- 1 Plywood Panel, 9in. by 6in.
  - 1 Baseboard, 9in. by 6in. by  $\frac{1}{8}$ in.
  - 1 .00015 mfd. tuning condenser, with slow-motion dial (Jackson Bros.).
  - 1 Dial pointer (Bulgin).
  - 1 .0001 mfd. reaction condenser (Jackson Bros.).
  - 1 Triple-range S.W. tuner (Lissen).
  - 1 Triple-range wavechange switch (Lissen).
  - 1 .0001 mfd. pre-set condenser (Colvern).
  - 1 .001 mfd. fixed condenser (T.C.C.).
  - 1 .0002 mfd. fixed condenser (T.C.C.).
  - 1 3 megohm grid-leak, with wire ends (Dubilier).
  - 1 S.W. valve-holder (Eddystone).
  - 1 S.W.H.F. choke (Bulgin).
  - 1 H.F. choke (Lewcos).
  - 1 Terminal block; marked "A" and "E" (Lissen).
  - 1 Wander plug; marked "H.T.+" (Belling Lee).
  - 3 Spade terminals: marked "L.T.+", "L.T.-" and "A" (Belling Lee).
  - 1 length "Glazite" connecting wire, 2ft. twin flex, screws.
- Approximate cost, 37s.  
Also, if required, 1 type 210 H.F. or 210 H.L. metallized valve (Coscor).

dial settings between these two extremes. Bear in mind that the tuning control of the Converter will also require adjustment as the receiver control is varied. This control is one of the most important, so that, for best results, too much time cannot be spent in finding the best setting.

### The Aerial

The aerial which is employed with the Converter will affect the setting of the small pre-set condenser in the aerial lead of this apparatus, and it may be found desirable to experiment with several different types of aerial. A short length of stiff wire, standing straight up from the aerial terminal, and about 12in. long, will be found to give remarkable results under some circumstances, and a similar wire, running from a

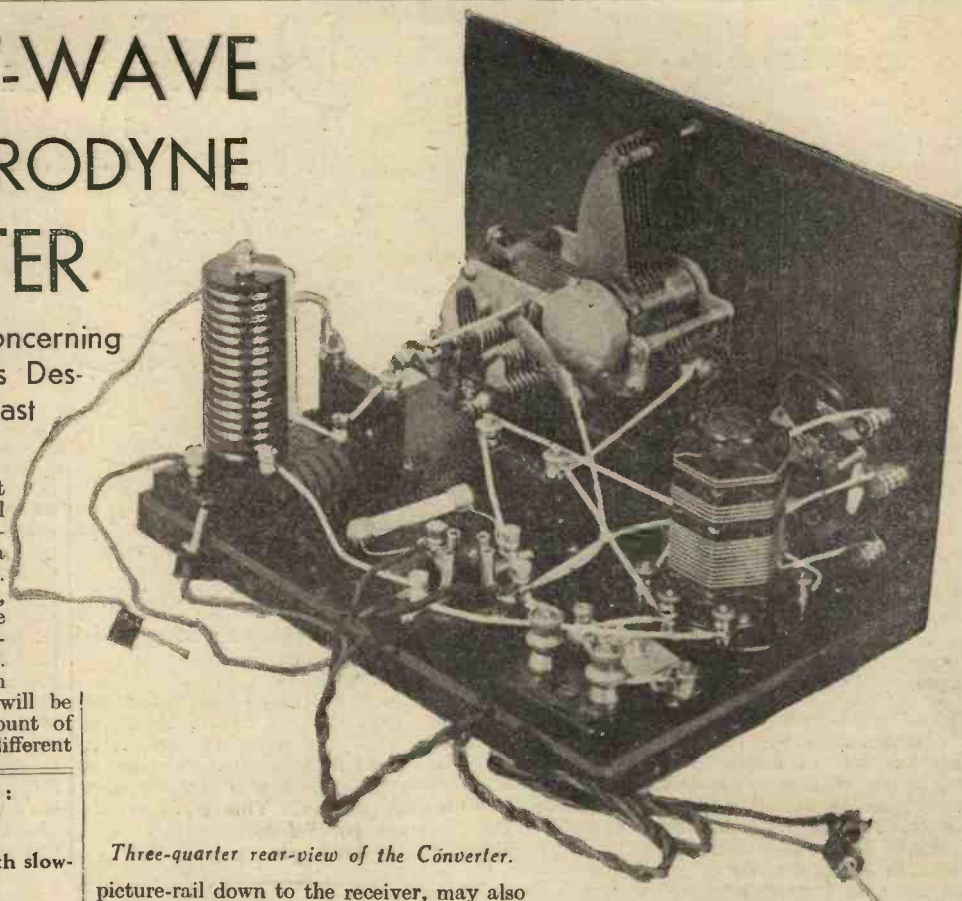

Three-quarter rear-view of the Converter.

picture-rail down to the receiver, may also be found advantageous. As the Converter covers three wave-bands, it will probably be found that it is not easy to find a setting of the pre-set condenser which will enable the maximum results to be obtained over the three wave-bands, and the alternative aerials should therefore be tried out so as to find one which will enable the three wave-bands to be efficiently explored. The great point to bear in mind is that the valve in the Converter must be kept oscillating the whole time, and if this is not so the Converter will not function properly.

### Tuning-in

When tuning-in a station, set the reaction condenser on the Converter so that the rushing noise is heard, and also set the reaction control of the receiver so that a fair amount of reaction is being employed in that part of the circuit. Now slowly rotate the tuning dial of the Converter until you hear a squeal. This will denote that a station carrier is being heterodyned, and you must proceed to resolve it into intelligible signals. Reduce slightly the reaction control of the receiver, and then slacken off the reaction condenser of the Converter. The silent point between the squeals will give the exact tuning position, and it will be found quite a simple matter to resolve the signal, although on all short-wave receivers tuning is exceptionally sharp. The tuning condenser is fitted with a very efficient slow-motion dial, but even so, it will be found that the slightest touch will tune past a station. Some of the best short-wave stations suffer rather badly from fading, so do not worry if you find that as soon as a station has been received it disappears. If you leave the controls alone you will find that it will return after a short while, and you will soon get used to the effect of this fading trouble. It is very

annoying to get a station, and, just as an announcement is about to be made, to lose the station and start adjusting the controls in an endeavour to bring it back, only to find that you have lost the spot altogether.

### The Earth

The earth connection will be found to be even more important than in ordinary broadcast reception, and we can only reiterate our previous remarks regarding this part of the installation. Remember that the earth must be in a moist condition if the resistance is to be kept low, and therefore you should use some preparation to ensure that this is effected. We cannot give a list of the stations that are likely to be received on this arrangement, as reception on the short waves varies in different parts of the country, and a station that is heard clearly in Devonshire may be inaudible, even on a more powerful receiver, in Yorkshire. This is due, of course, to the skip distance effect, and for this reason also it is not worth while trying to receive the Empire broadcasts from Chelmsford in this country. They may be received in some parts, but it is much more certain to try for one of the European or American stations which broadcasts on high power, especially when first exploring the short waves.

One final word should be given, and that is that the Converter will not work with receivers which have no high-frequency stages. The valve in the Converter acts as a combined first detector and oscillator, and the high-frequency stages in the broadcast receiver carry out the amplification of the signal at the new frequency. The detector valve in the receiver then again detects the signal and passes it on to the L.F. stages.

*A Few Core Wires Making Contact With Brass Strap*

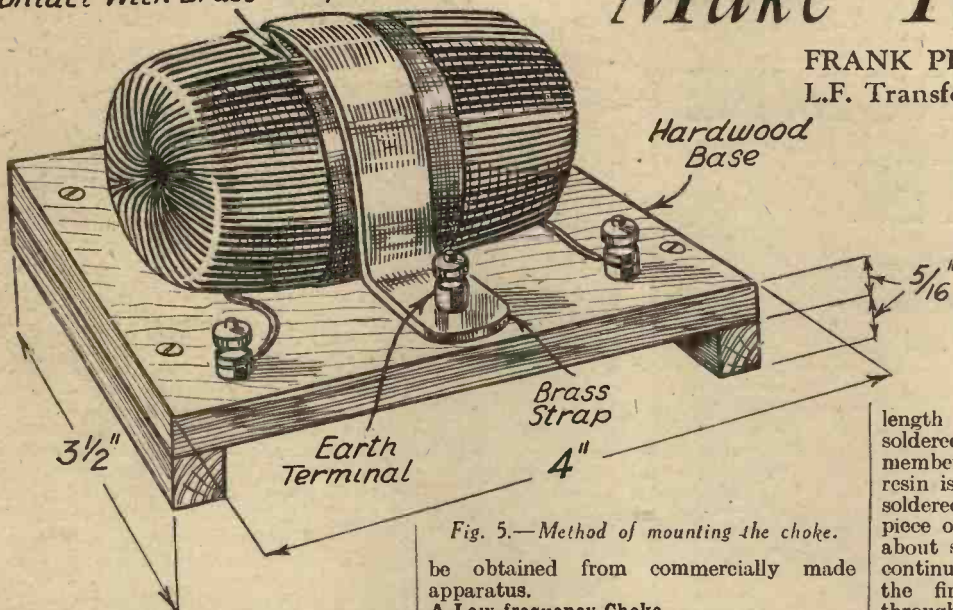

Fig. 5.—Method of mounting the choke.

It is perfectly clear by now that readers of PRACTICAL WIRELESS are, on the whole, distinctly practical people who are not content merely to buy a kit of parts, mount them on a chassis and connect from point to point by following a foolproof chart. Although they do appreciate a good receiver design and are prepared to follow it when building a new set, they also wish to keep an experimental set with which they can "tinker about" and learn exactly how each part functions. And, as those readers are aware, there is no better way of understanding how a component works than by making it. Now I would not suggest that every part of a receiver should be home-made, because in many cases the cost of the necessary tool equipment would be too great, but I will say that quite half of the components required can be made up at home by anyone with some mechanical inclination and having a fair amount of spare time.

I propose in this article to explain as simply as possible how a number of components can be made by using only those tools possessed by the average amateur. In each case, I shall assume the use of only the commoner woodworking tools, pliers, screwdriver, and soldering equipment, although some of the work could be simplified if a lathe were available. Furthermore, I shall only describe such parts as can be made economically and which will give results at least comparable with those to

be obtained from commercially made apparatus.

**A Low-frequency Choke**

Perhaps one of the easiest and most useful components which can be made at home is a low-frequency choke. A choke of this kind can be used for coupling L.F. valves on the choke-capacity principle, and for providing a choke output filter for the loud-speaker.

**Hedgehog Chokes**

In a previous article I described the construction of chokes requiring special Stalloy core stampings, so now I shall deal with a simpler and less costly type called, due to the shape, a hedgehog choke. This consists of a winding of copper wire placed on a bobbin through which is passed a bundle of soft iron wires. A sketch of the finished choke is given in Fig. 5, whilst the various stages of construction are shown in Figs. 1 to 4.

**The Winding Bobbin**

First, we must make a bobbin to accommodate the windings, and for this we shall require a strip of cartridge paper measuring 16in. by 3in., a 6in. length of 1/4in. dowel rod, some glue, a small piece of plywood, and some stiff cardboard or fibre. As a preliminary we must form a rigid tube from the cartridge paper by winding it tightly round the dowel rod; thin glue should be applied to the paper as it is being wound on. The next step is to make two plywood and two cardboard discs 1 1/2in. in diameter, and having a hole in the centre large enough to allow them to fit tightly on to the paper tube. A small notch should be cut in each of the cardboard discs, as shown in Fig. 2. All four discs should then be fitted to the tube, in the positions indicated in Fig. 2, with strong glue. Next, remove the bobbin from the rod.

# Make Your Own

FRANK PRESTON, F.R.A., Tells You  
L.F. Transformers, H.F. Chokes, Fixed

and put on one side until thoroughly dry and firm.

**Winding**

It can then be replaced on the rod in readiness for winding. The winding consists of 12,000 turns, or almost exactly 6 oz., of 38 gauge enamelled wire. The job of putting on the wire can be carried out much more easily if the reel is fitted on a small stand similar to that shown in Fig. 6.

Preparatory to winding, a 12in. length of rubber-covered flex must be soldered to the end of the fine wire; remember that a non-corrosive flux such as resin is best for this purpose. Cover the soldered joint with insulation tape or a piece of stamp edging, and wind the flex about six times round the bobbin. Then continue to wind on the thin wire until the first section is nearly full. Pass through the slot in the cardboard separator, and wind the second section, afterwards passing on to the third. Keep the turns as even as possible and take care that all three sections are wound in the same direction. When the whole 6 oz. of wire has been wound on, solder another 12in. length of flex to the end, and let this form the last three or four turns. Now cover all the wind-

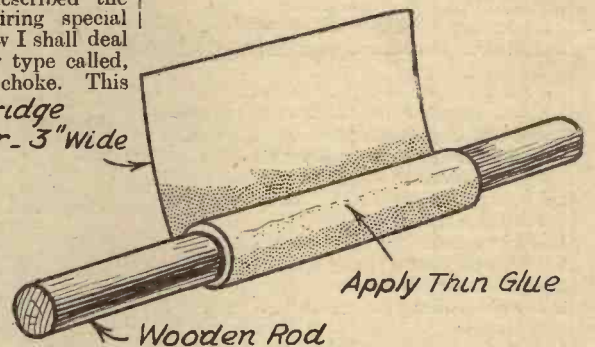

Fig. 1.—Making the tube.

ings with empire tape or ordinary insulation tape, taking care that no wire is exposed anywhere.

**The Core**

The core comes next, and is made from a bundle of soft iron wires 8in. long. It might be helpful to know that these can be obtained for a few coppers from most ironmongers or florists. The wire can usually be bought ready cut to lengths of 8 or 9in., and is sold by weight. It is essential that the wire should be really soft, and if you are in any doubt about yours, put it in a low fire on going to bed, and leave it overnight; that will certainly do the trick.

When the core is ready it should be pushed through the bobbin so that it projects by the same amount at each end. Make sure that it is a perfectly tight fit, and then bend the ends over the bobbin until they overlap in the middle. Of course, the two flexible leads must be brought through the core wires. Lastly, secure the core wires by binding with

*Core Wires Bent Over & Bound With Empire Tape*

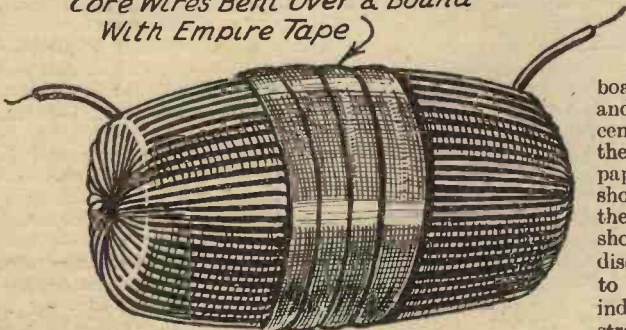

Fig. 4.—The finished choke ready for mounting.

# Components

## How to Make L.F. Chokes, and Variable Resistances, etc.

empire tape, dip the whole choke in a jar of shellac varnish, and allow to dry.

### Mounting the Choke

The choke can be mounted directly on the baseboard by means of a brass strap, or it can be made up in more finished form, as shown in Fig. 5. A small piece of well-seasoned hardwood is used for the base and terminals are attached to this. Ebonite could be used instead of wood, if preferred, but the latter has amply good insulation properties if thoroughly seasoned and dried. It will be noticed from Fig. 5 that a terminal is employed to secure the brass strap, and this can be used to earth the core if a few of the iron wires are pulled from under the empire tape and allowed to make contact with the brass.

### Characteristics

The choke described will give an inductance of some 80 henries when passing a D.C. current of up to 4 milliamps, and will, therefore, be ideal for choke-capacity coupling after either a detector or an L.F. valve. Its inductance when passing up to 20 milliamps D.C. will approximate to 35 henries, which is suitable for a choke-capacity loud-speaker filter after either a large or small power valve. The choke's D.C. resistance will be just under 900 ohms, and its maximum safe current-carrying capacity, 50 milliamps.

### A Pentode Output Choke

The inductance of the latter choke will be rather too low for efficient working as an output choke in the anode circuit of a pentode valve, but an excellent component for this purpose can be made by using a winding of 9 oz. 38 gauge enamelled wire on a larger bobbin or by putting 6 oz. of 40 gauge wire on the bobbin previously described. In either case, the actual construction will be exactly the same as that explained above. As 40 gauge wire is very thin and more difficult to handle, most constructors will prefer to use the

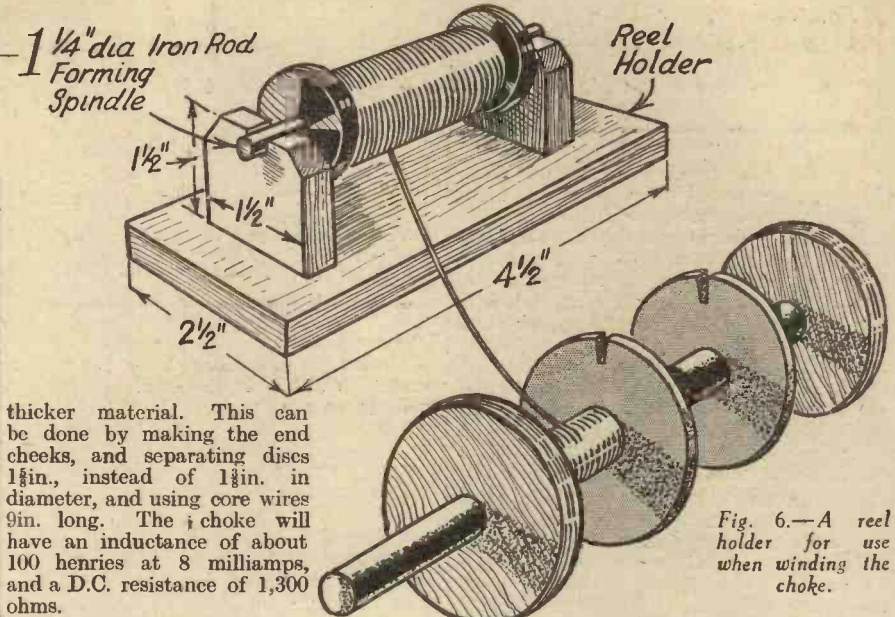

Fig. 6.—A reel holder for use when winding the choke.

thicker material. This can be done by making the end cheeks, and separating discs 1 1/2 in., instead of 1 1/4 in. in diameter, and using core wires 9 in. long. The choke will have an inductance of about 100 henries at 8 milliamps, and a D.C. resistance of 1,300 ohms.

### A Tapped Choke

When the choke is required for an output filter after either a three-electrode or pentode valve it is always useful to have

It is well to mark each tapping (by sticking on a strip of paper) for future identification.

### Smoothing Choke

A smoothing choke for use in an eliminator or mains set can be made in exactly the same way as the choke previously dealt with by using a larger bobbin and core. For a 30 henry choke capable of carrying up to 60 milliamps the core should be 1 in. diameter and 10 in. long. The bobbin should be 3 in. long, as before but the end cheeks and separators will need to be 2 in. diameter.

(To be continued.)

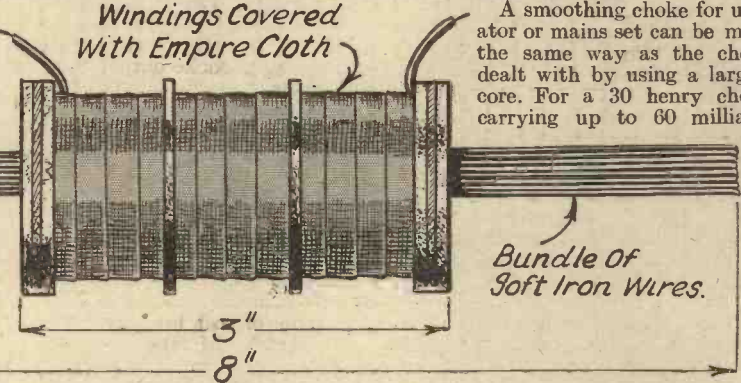

Fig. 3.—Wound bobbin with core wires inserted.

a few tappings so that the loud-speaker can be matched to the output valve. When a tapped choke is required, it will be best to make it like the larger one described, so that it can be used for almost any purpose. Tappings should be taken after winding one half, two-thirds and three-quarters of the wire. It will then give ratios of 1 : 1, 2 : 1, 3 : 1, and 4 : 1 when connected as shown in Figure 7.

The easiest way to make the tappings will be illustrated next week. The fine wire is bared of insulation for a distance of about an inch by carefully scraping with a sharp knife. A loop is made in the bared portion and a 12 in. length of flex soldered on. The joint is then covered with insulation tape or paper to prevent a possible short circuit with other turns. By winding the flex a few times round the bobbin and securing it with insulation tape the danger of damaging the fine windings by tension on the tapping is entirely removed.

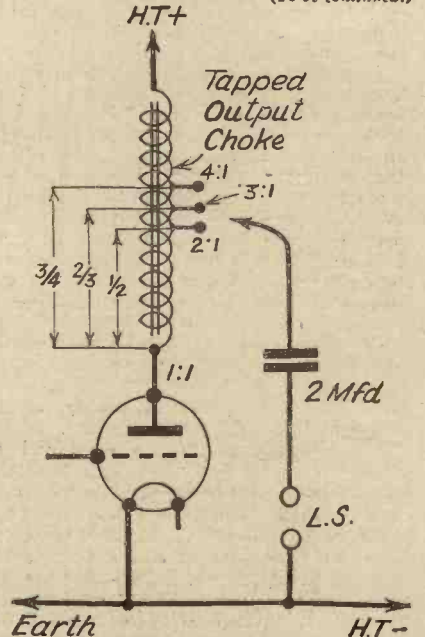

Fig. 7.—This diagram shows how different ratios can be obtained with a tapped output choke.

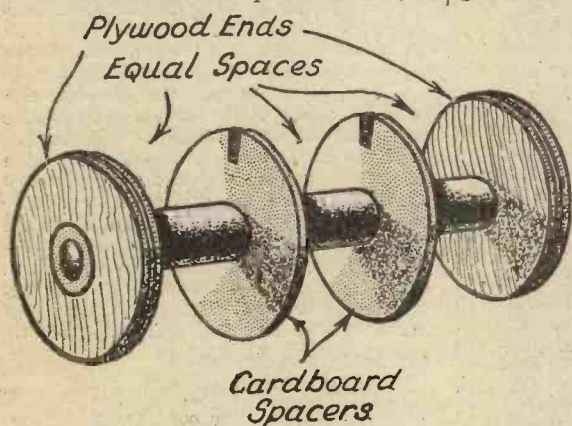

Fig. 2.—The complete bobbin.

# Thinking in Terms of Frequency

(PART 2)

The First Article Appeared on  
Page 637 of our Issue Dated  
December 17th.

It must be clearly understood that, although sound is a form of wave energy, it is transmitted through quite a different medium from that employed in radio. Radio waves are electro-magnetic in nature, and occur in the ether of space. Sound waves are purely mechanical, and the medium is the air. It will appear later how sound-frequency signals can be transmitted through the ether, but for the moment we must confine ourselves to the various sound frequencies themselves as they occur in Nature.

## Audio Frequencies

For all practical purposes the useful band of sound frequencies lies between about 16 vibrations per second up to about 12,000, but a receiver capable of reproducing with fidelity all frequencies between 50 and 8,000, or even 6,000, would be considered quite an efficient apparatus. The frequency indicates the "pitch" of the note or sound, the lower frequencies giving the lower, or bass, notes and the higher frequencies the upper, or treble, notes. It is useful to know that "middle C" on the piano corresponds to a frequency of 256 per second, and that for every octave above, the frequency is doubled, while for every octave below, the frequency is halved. Very few instruments give out a pure note of one single frequency. What they do give out is a main frequency, called the "fundamental," and a whole host of other frequencies, all bearing some simple mathematical relation to the fundamental. These are known as "harmonics" and "overtones," and the number and relative strength of them gives to each instrument its characteristic "timbre" or tone.

## Alternating or Periodic Electric Currents

Radio transmission depends upon the fact that it is possible to produce electric currents which vary either at radio frequency or at audio frequency. This is done at the broadcasting station. Special apparatus which cannot be described here is used to produce radio-frequency currents, while the microphone, of course, is the source of audio-frequency currents.

These two currents are combined to produce what is termed a "modulated" radio-frequency current—that is to say, a current which vibrates at radio frequency, while its amplitude varies in accordance with the variations in a sound-frequency current. This process is indicated graphically above. When the "modulated" current is applied to the transmitting aerial, a modulated radio wave is projected into space. When intercepted by your aerial, the energy of the wave is reconverted

into a modulated radio-frequency current, which is the raw material upon which your set has to work. In the detector stage the radio-frequency portion is filtered out, leaving the audio-frequency component to be further amplified before it is powerful enough to operate the speaker, in which the original sound is re-created.

## The So-called Side Bands

Because the receiving aerial picks up energy from a large number of stations, it is necessary to "tune" the receiver—that is, to make it particularly sensitive to the frequency employed by the station it is required to hear and comparatively

the quality of the reproduction is, under these conditions, very bad indeed.

The reason is that a modulated radio-frequency wave behaves in exactly the same way as if it were composed of a combination of an unmodulated wave with a number of other waves of slightly different frequency, some higher and some lower. The highest of these "side waves" has a frequency equal to that of the carrier plus the highest musical frequency in the modulation, while the lowest side wave has a frequency equal to the carrier frequency minus the highest musical frequency in the modulation. The side waves, therefore, are spread over a band of frequencies on either side of the carrier frequency, and are known as "side bands."

Mathematical analysis indicates that the existence of side bands is a reasonable working theory; it is proved by experience that the effects of side bands are manifest; but it is impossible to prove their existence, and very difficult even to obtain a clear mental impression of them.

There are, as a result, two schools of thought on the side-band question, one maintaining that there are side bands and one denying that they can exist. Probably it is all a matter of how one thinks of these things. To most of us "amplitude modulation"—that is to say, a varying height of wave, produced by the audio-frequency modulation—is the easier to imagine; others, however, may be able to obtain a better mental picture of a band of frequencies grouped round the carrier frequency.

However one looks at it, the practical fact remains that unless the receiver is sufficiently flatly tuned to pass a certain band of frequencies on each side of the carrier wave, distortion will occur. It is not an easy matter so to arrange the tuning that, while accepting a sufficiently wide band to ensure good quality, the side bands of interfering stations are excluded. The many variants of the "band-pass filter" system of tuning achieve a very good measure of success in accepting a sufficiently wide band of frequencies

to maintain a high standard of performance and at the same time ensure selectivity.

An alternative scheme, which has been proposed and actually used in one or two wireless receivers, achieves a high degree of selectivity by using very sharply-tuned radio-frequency circuits, thus at the same time severely clipping the side bands. Then, to replace the lost quality, a certain amount of amplitude distortion is deliberately introduced in later stages of the receiver.

## Supersonic Frequencies

There is one more "trick" with frequencies which should receive passing

(Continued on page 746.)

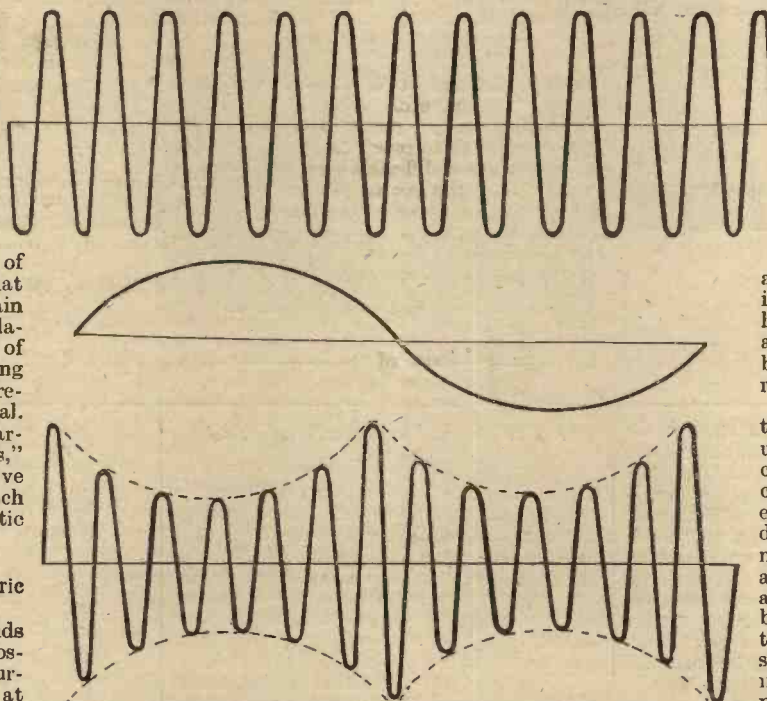

Diagram showing (top) carrier wave of uniform amplitude; (centre), Low frequency wave, and (bottom), modulated carrier wave.

insensitive to all other frequencies. The broadcasting systems of Europe are so organized that certain standard frequencies are allotted to different stations, these frequencies being spaced over the available broadcasting band at intervals of nine kilocycles. Now it is quite possible to design a receiver in which the tuning is so "sharp" that the set only responds to frequencies differing only slightly from the official frequency of the "wanted" station. Such "razor-edge" tuning, it may be thought, would be ideal, for it avoids all risk of interference from other stations. Avoid interference it does, but, nevertheless, it is far from satisfactory. It is found that

THE HALF-GUINEA PAGE

# Radio Wrinkles FROM READERS

**Switching Arrangement for Loud-speakers**  
THE accompanying diagram, below, shows the connections for switching two loud-speakers, using a double-pole, double-throw switch. The advantages of this type of switch are its good contact and its quick action in switching from one speaker to the other. For making good connection to the speakers, plug-in coil holders are very handy. Two holders can be screwed to the cabinet or on to the wall,

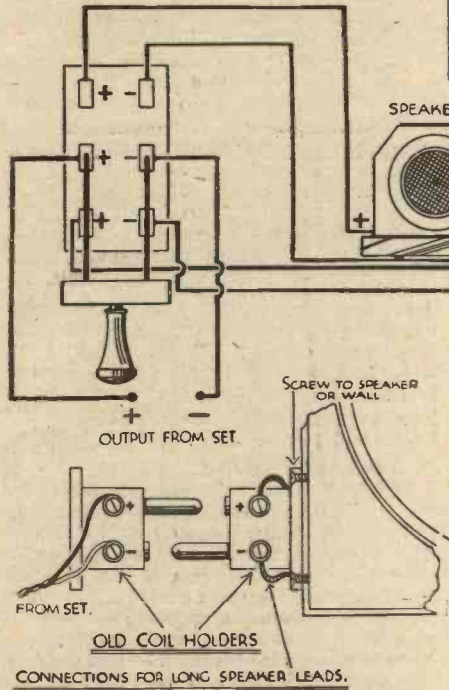

CONNECTIONS FOR LONG SPEAKER LEADS.  
A switching arrangement for loud-speakers.

the other two being attached to the leads from set, thereby permitting a quick removal of either speaker without having to disturb the whole length of flex, which can conveniently be run round the picture rail down to the speakers.—WILLIAM WILSON (Greasbrough).



How to make your own screened lead for connecting to the top of an S.G. valve.

## THAT DODGE OF YOURS!

Every reader of "PRACTICAL WIRELESS" must have originated some little dodge which would interest other readers. Why not pass it on to us? For every item published on this page we will pay half a guinea. The latest batch is published below. Turn that idea of yours to account by sending it in to us, addressed to the Editor, "PRACTICAL WIRELESS," George Newnes, Ltd., 8-11, Southampton Street, Strand, W.C.2. Put your name and address on every item. Please note that every notion sent in must be original. Mark envelopes "Radio Wrinkles."

**Screening S.G. Leads**  
HERE is an idea which will no doubt prove useful to readers who wish to make their own screened

leads for connection to the top of the S.G. valve, Pick-up, etc. Procure a piece of expanding curtain runner and cut to the length required to cover the lead. A length of rubber-covered flexible wire will pass very easily down the centre of the "runner," the ends of which should be bound up with insulation tape to prevent the earthed covering slipping down on to the bare end of the rubber-covered wire, resulting in a short circuit of the H.T. supply. If the last coil of the "runner" is bent into the form of a loop, at right-angles to the wire, it may be screwed down to the base-board as shown in the accompanying sketch, and the springiness of the runner will keep it in an upright position when the lead is disconnected

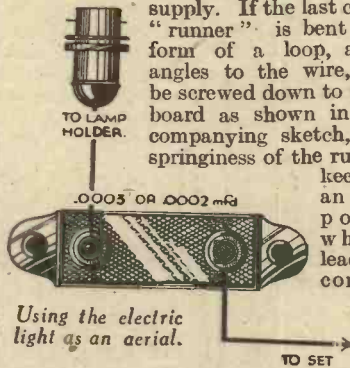

from the top of the valve.—CHARLES E. CURTIS (Waterloo, Lancs.).

**Using Electric Light System as an Aerial**  
HERE is a little dodge which enables the electric light system to be used as an efficient indoor aerial. A length of wire is connected to one of the metal contacts of a lamp holder adapter, and the free end of the wire to the terminal of a .0003 mfd. or .0002 mfd. mica condenser (preferably one tested to 500v. A.C.). Another wire is attached to the other terminal of the condenser, the free end of this wire being connected to the aerial of the set, as indicated in the

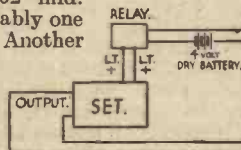

accompanying sketch.—ERIC EVERSFIELD (Ulverston).

## Short Earth Lead

AN efficient and short earthing device can be arranged in the following manner:—Every house is provided with air ventilators under the floorboards, and all that has to be done is to find the ventilator which is near the

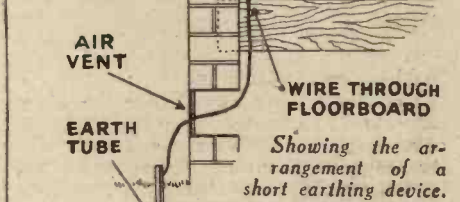

ground. Take the measurement from the nearest ground-floor window, and from the inside drill an 1/8 in. hole in the floor-board directly over the air vent, close to the skirting-board. Pass the earth wire through this hole, and, with a piece of wire bent to form a hook, pull the earth wire through the ventilator and fix it to the earth tube.—J. T. HOWARD (Grove Park).

## A Cheap Remote-Control System

I HAVE this small remote-control layout working very satisfactory. It is very simple to make, and each room is in full control of the set. The relay is a Polar, picked up cheaply, and works for months on a four-volt dry battery. The set must have an output filter unit. The wiring and the switches are clearly shown in the accompanying illustration. This arrangement does away with the trouble of going from room to room to switch the set on and off, and is well worth the time taken wiring up.—W. J. WILLIAMS (Leamington Spa).

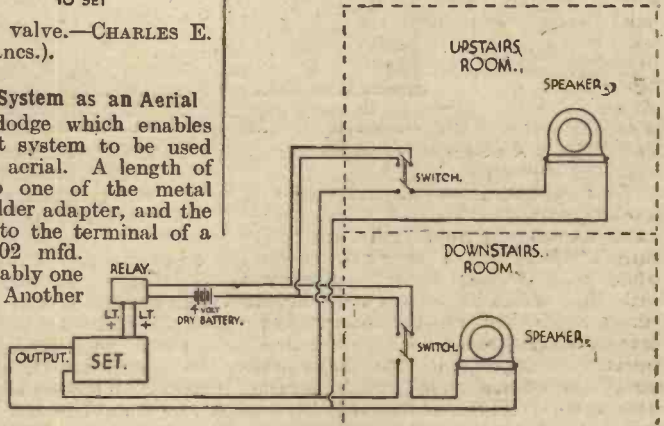

A remote-control system for room-to-room working.

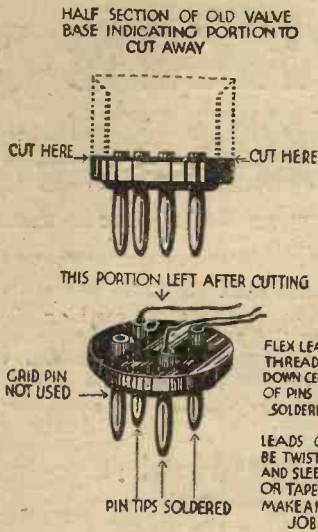

An improvised coil adapter.

**Short-Wave Adapter Plug**

THE illustration shows a half section of an old valve base, and a pictorial sketch of a useful plug for a short-wave adapter. By simply cutting away the side of valve base the plug part is left. After making the plug thread a flex lead down three of the valve pins (anode pin and the two filament pins). The flex leads should be soldered at the pin tips. This is quite easy, as most valve pins are soldered by the manufacturers. To make a neat finish to the plug the flex leads can be sleeved or taped.—G. H. LEECH (North Ormesby).

**A Use for old H.T. Batteries**

WHEN the voltage of an H.T. battery drops to half of its original value, we consider its useful life is at an end, and so discard it. There is generally some odd corner about the house in which a little light would be handy. Such a light

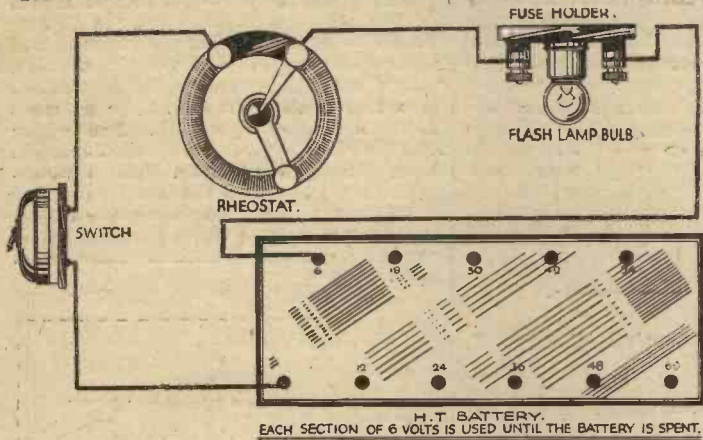

A use for old H.T. batteries.

can be rigged up from old parts you may have lying about. Those required are:— 1 small tumbler switch; 1 fuse holder (flash lamp type); a partly used H.T. battery; 2 wander plugs; some twin flex. Most H.T. batteries are tapped every 6-volts, but even an old battery may show more kick than a 3.5 bulb can stand. Therefore, a safety refinement is the addition of the once popular 7 ohm rheostat. I have used this idea in an out of the way cupboard with an automatic switch, similar to that described in PRACTICAL WIRELESS

dated November 5th, under the heading "Switch for a Portable Set," except that the button was not used. Quite long service has been given by batteries which were no good for radio purposes. When the battery is tapped every 12 volts it is necessary to break open the pitch and use crocodile clips for the connections. The accompanying diagram shows the connections.—G. S. GRAHAM (Edinburgh).

**Simple Remote Control**

AN easy method of enjoying radio in bed, and not having to walk to the set to switch it off, is as follows: Obtain a length of 4-core flex to requirements; one double-pole double-throw switch, and one single-pole double-throw switch; a piece of wood, 6in. by 3in.; an old filament resistance, and two terminals. The switches are fixed behind the set, while the block with its two terminals and rheostat mounted upon it is fitted up by the bedside. The diagram shows the connections. Having done this, the operation is carried out in this manner. When the switch handles are pointing down, this works the set with its speaker in the ordinary way. When

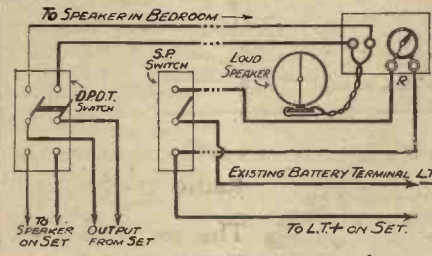

Another form of remote control.

the switch handles are up, the loud-speaker in the bedroom will be fed. The rheostat acts as a volume control and also a switch. When the knob is turned to the extreme left the speaker is silent and the L.T. positive lead is broken, thus switching off the set. If one speaker has to serve the two rooms the switches can be dispensed with and the connections made direct, to suit either case.—J. H. ATKINSON (Fishergate).

**Three Point Location for Speech Coil**

DURING a series of experiments with a moving-coil speaker, I required a simple means of locating the speech coil, to enable the latter to be readily examined and adjusted during these experiments. The device can be made as follows:—Firstly, procure two brass rings of as large a diameter as can be accommodated on the magnet pot. Drill three clearance holes for a four B.A. screwed rod, equidistant round the edges. Using these holes as centres, glue three pieces of thin leather,

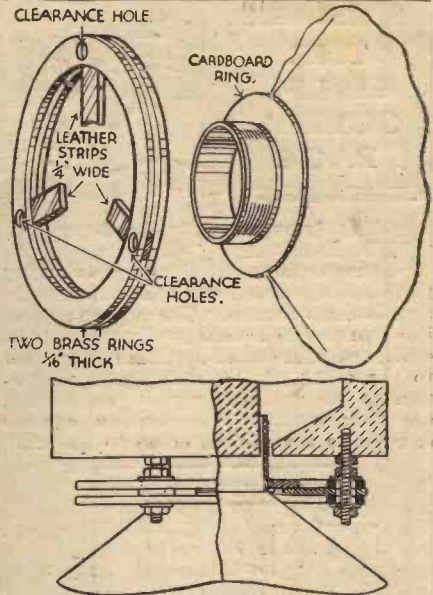

A simple method of adjusting and speech winding.

about 1/4in. wide (AB and C) between the rings. In turn, these pieces of leather are glued to the cardboard ring which has been fixed upon the speech coil, again at points A, B and C. The whole assembly is then set upon three 4 B.A. screwed rods which are set into the magnet pot. By means of nuts, the coil can be adjusted either inwards, or outwards; also, due to a clearance being in the holes in the rings, a lateral adjustment is obtained.—C. CROWLEY (Birmingham).

**Push-Pull Amplification**

HERE is a method which gives all the advantages of push-pull working without the rather heavy cost of centre tapped transformers. Most of the parts required, which are given below, will be found in your original receiver if it incorporates an output filter circuit: One 4-1 or 3.5-1 transformer; Two 20 Hy. at 40 m/A. chokes; Two 2 mf. 500 v. test (or higher, if necessary) condensers; One 50,000 variable potentiometer. The circuit is shown in the accompanying diagram. In order to be sure that each valve is getting its full share of current, a milliammeter should be joined in series with the plate of each valve in turn, and the potentiometer adjusted until the reading from each valve is equal. The valves used will, of course, depend on the H.T. supply available; for battery sets two small power valves give excellent results, such as Osram L.P.2S or Mullard PM2S. Where the H.T. supply is adequate such as with a suitable mains unit, two such valves as the Marconi PX4 will give a greater output.—E. NEASON (Coventry).

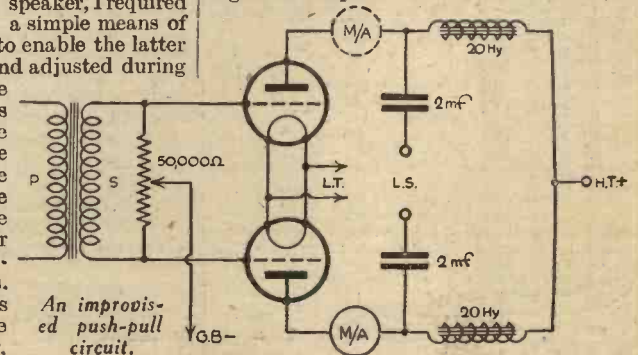

An improvised push-pull circuit.



FOR REGULAR READERS ONLY

# SPECIAL OFFER

## "PRACTICAL WIRELESS" DATA SHEETS

# BINDER



NOTE the stout linen-covered stiff board cover specially made to withstand hard wear.

These are special press-button studs securing the Data Sheets under the neat linen flap and keeping all trim and tidy.

This is a useful manilla gusset-pocket for holding loose sheets, newspaper clippings, notes and other odds and ends.

The "Practical Wireless" Data Sheets Loose Leaf Binder measures 11ins. by 5ins. and is strongly made in full cloth on stiff boards having a special flap with cloth hinges and enamelled press-button fittings for speedy insertion (and removal) of the Data Sheets which are specially "holed" to fit.

## This is Your LAST OPPORTUNITY!

**R**EGULAR readers of "Practical Wireless" who have not already reserved their Data Sheets **BINDER** should do so now. These Binders are being expressly made to contain the "Practical Wireless" Data Sheets for permanent reference, and will undoubtedly prove most valuable to all Radio constructors.

The only way to secure your "Practical Wireless" Data Sheets Binder is to fill in and post the Reservation Form *at once*. As you will see from the conditions below, there are no Gift Stamps to collect. If you are a Regular Reader of "Practical Wireless" you are eligible for a Binder provided, of course, you comply with the simple conditions. Your Reservation Form must reach us during the next few days—better fill it in and post to-day.

The date on which the Binders will be ready for despatch will be notified in "Practical Wireless" early in the New Year.

## NO GIFT STAMPS TO COLLECT

### READ THESE SIMPLE CONDITIONS

*There are no Gift Stamps to collect*

To qualify for your Data Sheets Binder you must complete and sign the Reservation Form on this page, and if you have not already done so, give your Newsagent an order to deliver (or reserve) a copy of "Practical Wireless" every week. Send your Reservation Form to "Practical Wireless" Presentation Department, 39, King Street, Covent Garden, London, W.C.2.

When your Reservation Form is received, and directly supplies of Binders are available (readers will be notified by an announcement in "Practical Wireless"), each applicant will be required to forward a postal order for 1s. 6d. to include registration, postage, packing, insurance, etc. Immediately on receipt of this, your Binder will be despatched.

**SEND YOUR RESERVATION FORM TO-DAY!**

### RESERVATION FORM for P.W. DATA SHEETS BINDER

*No acknowledgment of this form will be sent*

In accordance with the conditions of your special offer, please reserve for me one PRACTICAL WIRELESS, Data Sheets Binder.

Reader's Name.....

Full Address .....

The Newsagent who supplies me weekly with PRACTICAL WIRELESS is:—

Name .....

Address .....

Reader's Signature.....

Leave blank

No.

Post to PRACTICAL WIRELESS, Presentation Department, 39, King Street, Covent Garden, London, W.C.2, in unsealed envelope (3d. stamp only).

# A TALK ABOUT "—ANCE," "—IVITY" AND "—OR"

By "CYNIC"

THE beginnings of the twin sciences of Magnetism and Electricity date back more than two thousand years, and developments continued through the centuries, at first slowly, then more quickly, and, in recent years, at an extremely rapid pace. It is one of the penalties which we must pay for this long period of growth, extended over times of very varied methods of thought and carried on by men of many different nations, that the terminology of the science has become somewhat confused. An ideal nomenclature would be one in which all terms referring to the same phenomenon would have the same stem or root word, and all terms referring to the same aspect of different phenomena would have the same ending.

To a certain degree this system is followed in modern technical terminology. Thus, we have *resistance*, *resistor*, *resistivity*, all referring to different aspects of the opposition offered to the flow of electric current by various bodies. Similarly, we have *conductance*, *resistance*, *inductance*, *capacitance* and so forth, as names applied to similar aspects of different properties of an electric circuit.

As we shall see, however, electrical and radio terminology is not perfectly consistent. For example, we have *resistance*, and *resistor*, and we have *impedance*, but not *impedor*. The piece of apparatus which, if we were really consistent, we should call an *impedor*, we have to call a "choke." Other examples of inconsistency will be mentioned later on. In many cases, one word is made to serve for several meanings; in other instances, several words have identical or almost identical significance. But although our present system of technical terminology is far from ideal, there is no need to make matters worse by applying such terms as exist in a loose or incorrect manner.

The following notes will, it is hoped, explain the strict and correct significance of a number of commonly-used electrical radio terms, and may help to clarify our ideas as to the principle according to which they should be applied.

## "Resistance"

Let us begin with the familiar word "resistance." One of the earliest facts observed after the discovery of the flow of electric current was that the strength or intensity of the current depended upon the length of the circuit. Further investigation revealed that different bodies offered different degrees of opposition or "resistance" to the flow of current. It was discovered that the resistance of a long wire was greater than that of a short wire; that of the thick wire less than that of a thin wire; and that wires of equal length and thickness but made of different materials showed different powers of resistance.

The title of the property which causes this opposition is "resistance," and here it may be stated that, in general, all terms ending in "ance" are the names of properties. The term "resistance," how-

ever, is also used quantitatively and in conjunction with a suitable unit is employed to denote the amount of opposition offered by a given piece of apparatus. Thus, we may say that a certain circuit has a resistance of 20 ohms, the ohm being the unit of resistance in the same way that a pound is the unit of weight.

When a piece of apparatus having a definite value of resistance is included in a circuit primarily in order to make use of its resistance or of some effect caused by its resistance, it is called a "resistor." For example, we may desire to reduce the voltage applied to the anode of a valve, and we can do this by inserting a suitable resistor in the high tension circuit. Unfortunately, a good many of us, including leading technicians who ought to know better, have contracted the habit of calling a resistor a "resistance." Strictly speaking this is definitely wrong. It is as incorrect to go into a radio shop and ask for a "10,000 resistance" as it is to ask your grocer for a weight of two pounds. What you require in the first case is a resistor having a resistance of 10,000 ohms, and in the second a piece of, say, cheese, having a weight of 2 lbs.

## "Resistivity"

There is one more term in connection with resistance which requires explanation, namely the word "resistivity." All terms ending in "ivity" refer to the amount of a given property possessed by a given body under specified conditions. In the case of resistivity, the term is employed to indicate the way in which the resistance depends upon the material of which the resistor is made. This was at one time known as the "specific resistance" of the material, but is now called the "resistivity," or more correctly the "mass resistivity" of the material. The mass resistivity is the actual resistance of a cube of the material under discussion, the side of the cube being exactly one centimetre, and the resistance being measured between opposite faces. When the mass resistivity of any material is known, it is a simple matter to calculate the actual resistance of a wire of any length or diameter made of that substance.

We will now leave resistance and examine other properties of an electric circuit and see how the various terms connected therewith are related to each other. Because the opposition to electric current is termed resistance, we will expect that the ease with which current is allowed to flow will be called "conductance," and that a piece of material which allows current to pass through it will be called a conductor. Conductance being the opposite of resistance, we find that it is measured by the reciprocal of the resistance, the unit being the "mho" (ohm spelt backwards). A wire having a resistance of 10 ohms has a conductance of one-tenth of a mho. The specific degree of conductance possessed by any material is expressed as its conductivity. Thus, a metal such as copper which has a low resistivity has,

therefore, a high conductivity, and the material such as "eureka" having a high resistivity, has a low conductivity. Materials which have very high resistivity and thus poor conductivity, are called insulators.

## "Impedance"

Now another term, analogous to resistance, namely, "impedance." This property, sometimes called the "apparent resistance," is the opposition to an alternating current. It is measured by the same unit as resistance—the ohm, but differs from resistance in that its value depends upon the frequency of the alternating current.

## Inductance

We now come to the question of inductance. Inductance is the property possessed by a circuit or piece of apparatus by virtue of which an electromotive force can be produced in the circuit due to changes in the magnetism of the circuit. The change of magnetism can be caused by a varying current in another circuit, when the inductance is termed "mutual inductance," or by a varying current in the circuit itself, when the effect is called "self inductance."

Here again, we have not "inductivity" to indicate the degree to which inductance is possessed by a piece of apparatus, but the inductance (sometimes called the "coefficient of induction") is measured in terms of a unit called the "henry," a coil of one henry inductance being one in which an electromotive force of one volt is generated when the current is changing at the rate of one ampere per second. There is a term "inductive" which is used to indicate that a circuit or piece of apparatus is so designed that its self inductance is, for the conditions under which it will be used, appreciably greater than its resistance. Frequently used almost in the same breath with inductance is the term "capacity" or, as it should properly be termed, "capacitance." This is the property possessed by a piece of apparatus usually called a condenser, but which some engineers now call a "capacitor."

## "Capacitor"

A condenser, or "capacitor" consists of two conducting plates or sets of plates, separated by an insulating material. Naturally, such an arrangement will not pass a direct current, but, if a steady voltage is applied between the plates, there is a momentary rush of current, and a certain quantity of electricity flows into the condenser, and is stored in the form of electrical stress in the insulating medium between the plates. When the electromotive force is removed, the charge remains stored, that is to say, there will still be a difference of electric pressure between the two plates, so that if they are connected together a rush of current will occur as the accumulated charge is dissipated. Numerically the capacitance of a condenser is measured in farads or in microfarads, a condenser of one farad capacitance being one requiring a current of one ampere flowing for one second to charge it to a pressure of one volt.

# THE AUTOKOIL PENTODE TWO

A Powerful Duet of Valves—A Unique Tuner and a CHEAP Set Combined

**T**HIS is a new two-valve receiver in which construction has been reduced to the minimum, and in which the principal parts of the circuit, especially on the aerial side, are all contained in one unit. We refer, of course, to the Autokoil, which has been designed and manufactured by A. W. Hambling. This is a complete all-wave tuner employing a coil wound on an air-spaced former with a tapped selectivity device and reaction control. This is built up on an ebonite plate provided with the three essential controls, and for those readers who require it a special escutcheon is provided at an additional cost of 1s. The complete receiver employs this unit as the main panel mounting fixture, the remaining panel parts consisting of a tuning condenser and on-off switch.

A perusal of the list of components will show that a 7 to 1 transformer is employed for coupling a detector valve to a pentode, in the anode circuit of which is a tone compensator. Ample decoupling is provided, and the receiver will be found perfectly stable in use. A fuse is incorporated to safeguard the valves against damage occasioned by short circuits. The remainder of the circuit details are quite straightforward and are standard.

### Construction

As with any receiver, the first part of the work to receive attention is the panel. This should be marked out, using the Autokoil for the accurate placing of the three holes required for this unit. The central hole is a 3/8ths clearance hole and the two outside holes are required for the one-hole fixing bushes which retain the unit in position. The switch and variable condenser may be attached in any position, and there is no need to give any measurements for these, provided they align with the other knobs. Before mounting these components, mark out and drill the terminal strip. The components which are to be mounted on the base-board should now be placed

### WIRING DIAGRAM OF THE AUTOKOIL PENTODE TWO

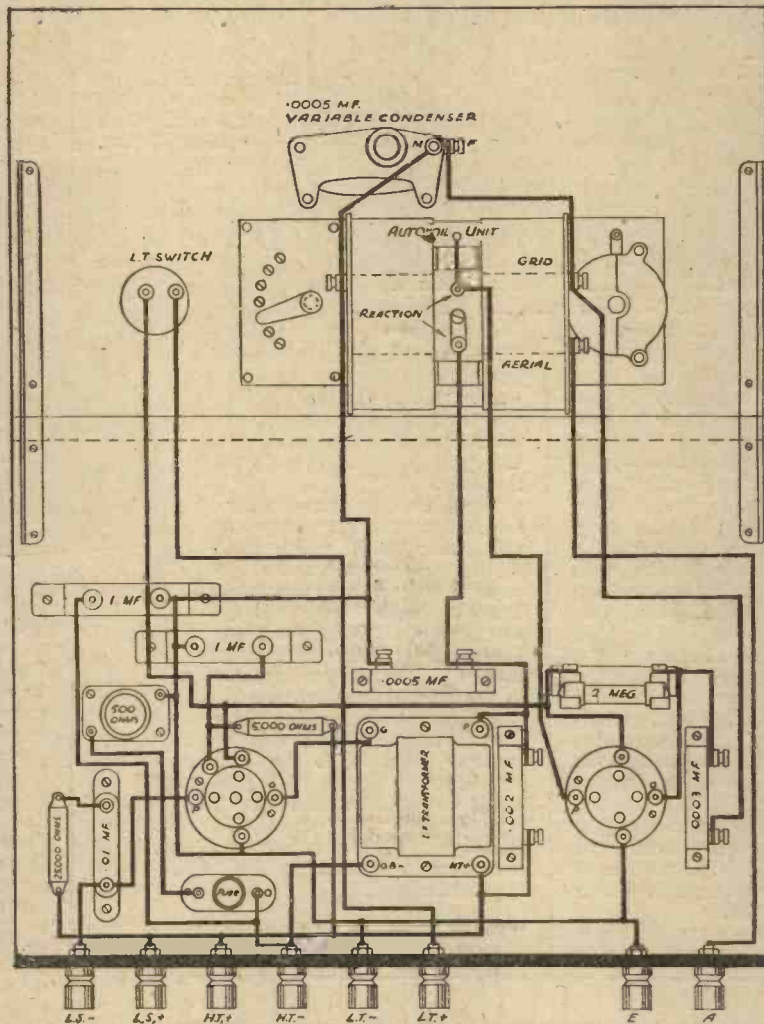

in their relative positions and when perfectly sure that sufficient clearance is given in all places drive home the necessary screws. Mount the Autokoil unit, and, if desired, one of the special escutcheons should be obtained for this. It consists of a thin ebonite plate on which the degrees for the selectivity control and other useful guides are marked, and it costs 1s. extra. It not only adds to the appearance of the finished receiver, but greatly simplifies the adjustments required for the various stations which may be received. Wiring may now be carried out, and this will present no difficulty if the wiring diagram is kept beside the work. There are very few wires required, owing to the employment of the tuning unit, and the whole job should not take more than an hour.

### Testing Out

Into the first valve-holder (that is, the four-pin socket) plug a Cossor 210 H.F. or a 210 det. The former will be found most suitable in outlying districts, or for those listeners who live some distance from a main station, whilst the 210 Det. will be better for those who have trouble due to the close proximity of a powerful transmitter. The pentode is plugged into the remaining socket, and the batteries may then be connected up.

It will be noticed that there is only one positive terminal for the high-tension supply, all the voltages required in the circuit being obtained either direct or through resistances. Join the loud-speaker, making sure that the leads are attached to the correct terminals, and the receiver is ready for testing. Turn the right-hand knob of the unit as far as it will go to the right, the left-hand knob about half-way round, and the centre knob also to a midway position. Pull out the switch, and if the receiver oscillates at once rotate the centre knob until reaction ceases. The direction will not matter, as a full 360 deg. rotation is obtainable on this control. Simply, therefore,

(Continued on page 746.)

### LIST OF COMPONENTS FOR THE AUTOKOIL PENTODE TWO

- 1 Autokoil All-Wave Tuner (A. W. Hambling).
- 1 .0005mfd. Polar No. 2 Variable Condenser.
- 1 .0003mfd. T.C.C. fixed condenser, Type S.
- 1 .002 " " " " Type S.
- 1 .0005 " " " " Type S.
- 1 .01 " " " " Type 40.
- 2 1.0 " " " " Type 50.
- 1 2 Meg Grid Leak (Lissen).
- 1 Watmel 500 Ohm. Bias Resistance.
- 1 Varley 5,000 Ohm Resistance.
- 1 Varley 25,000 Ohm Resistance.
- 1 W.B. 4-pin valveholder.
- 1 W.B. 5-pin Valveholder.
- 2 Valves—210 H.F. (or 210 Det.—see text) and 230 H.P.T. (Cossor).
- 1 Telsen 7-1 L.F. Transformer.
- 8 Clix Terminals marked L.S.+, L.S.—, H.T.+, H.T.—, L.T.+, L.T.—, Aerial and Earth.
- 1 Fuse and Holder Type, F.5 (Bulgin).
- 1 Terminal Strip 12in. by 1 1/2in.
- 1 Pair Bulgin Panel Brackets.
- 1 Bulgin Type S. 85 On-off Switch.
- 1 Lissen 120 volt H.T. Battery.
- 1 Lissen 2 volt Accumulator.



A family group looking in at a "televisor" to watch the television programme.

# WHAT is TEL

A Continuation of the Series of Articles Explaining the Principles of Television.

THE last three articles in this series have dealt mainly with the transmitting side, for I felt that in presenting to readers the general outline of a new science, it was necessary to learn something of how the television signals are produced before we take up what many regard as the more interesting part, namely, the receiving end. This has now been done, and we can picture our television signals as being the electrical and optical disembodiment of the scene in the television studio flashed piecemeal into space. Our attention must, therefore, now be focused on simple ways and means of reassembling these signals so that they become an intelligent image to be watched by one or more people at the receiving end. Obviously, a wireless receiver is necessary, but at the moment this need not concern us very largely. One to tune in the London National station on 261 metres is necessary, if the normal nightly programmes are to be watched, but an ultra-short-wave receiver will be required if advantage is to be taken of an interesting fact which has just been made public.

It is to the effect that transmissions of television by the Baird process are now

These transmissions are entirely experimental, the subjects transmitted being, for the most part, the artists rehearsing in the television studio in preparation for the regular television transmissions.

The ultra-short-waves offer the advantage of a very large available wave-band, which enables pictures with much more detail, and no flicker, to be transmitted. Images with 90 lines, and up to as many as 240 lines, in place of the present 30 line pictures, have been transmitted experimentally in the Baird laboratories, and when ultra-short-wave broadcasting becomes established, the result of this research will become available to the public. In the meantime, amateurs with ultra-short-wave receivers will be able to take advantage of the test transmissions from the B.B.C. aerial, but before so doing, it is necessary to learn something of the vision apparatus itself.

### "Re-integrating" Apparatus

A little thought should make it clear

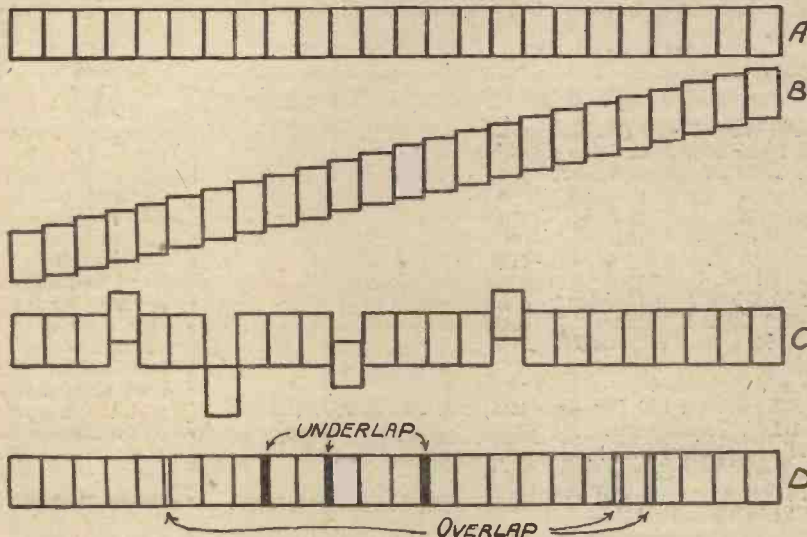
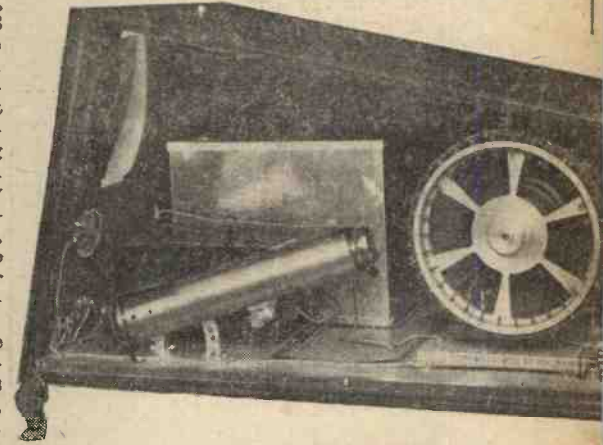

Fig. 2.—This diagram illustrates the effects of holes which do not accurately align. It will be seen that the picture will be broken in various ways. The top line shows how the holes should join up.

being sent out on Wednesday and Friday of each week, from 3 p.m. to 5 p.m., on the 7.3 metre B.B.C. transmitter at Broadcasting House.

to the reader that in the "re-integrating" apparatus, we must have material which resembles somewhat the "disintegrating" apparatus, except that the process is to



An experimental form of mirror drum television receiver which projects the image on to a front screen.

be reversed. Scanning at the transmitting end was carried out at the rate of 12½ pictures per second, that is, 750 revolutions per minute, and in consequence, we shall require a motor to effect this in the receiving apparatus. The power of this motor will depend upon whether a disc or a mirror drum is being employed for scanning, both these types of apparatus being shown in accompanying illustrations. In either case, the motor may derive its power from the D.C. or A.C. house mains, or accumulators, and be capable of running at a speed of 750 revolutions per minute for long periods at a stretch. Furthermore, the motor should be capable of easy speed control, so that the "looker" (this, by the way, is the word suggested by the B.B.C. to be equivalent to the "listener" of ordinary sound programmes) can make any adjustments rapidly, if his motor speed does tend to change.

Next, we shall require a mirror drum or a disc, and on the score of cheapness and simplicity, the latter is the obvious choice and will, at least, be adhered to for the purposes of explanation. In practice, this disc is made from fairly thin sheet aluminium—No. 32 S.W.G. is very satisfactory—and to still further lighten it, large sectors are removed, giving the finished product the appearance of a five or six-spoked wheel, as shown in an illustration of one form of receiver. The resultant "flimsy" character of the disc is valuable, inasmuch as it will allow it to whip out flat when mounted on the motor shaft and run up to speed. It then functions as a solid disc without the object of weight.

### Apparatus for Home Use

For a simple machine to use in the home,

# TELEVISION? (4)

By H. J. BARTON CHAPPLE,  
Wh.Sch., B.Sc. (Hons.), A.C.G.I., D.I.C., A.M.I.E.E.

a diameter of 20in. is satisfactory, and around the edges of this disc must be punched a single turn spiral of thirty holes, spaced apart twelve degrees radially. To receive the B.B.C. transmissions, this spiral of holes must turn towards the centre in a clockwise direction. Then, when the disc is rotated in its correct direction, namely, anti-clockwise, the scanning operation will be in order, that is, hole movement from bottom to top and strip direction from right to left.

Unless the holes are accurately positioned, both in a radio and circumferential direction, a mechanically distorted image will result. For a correctly marked out receiving disc, the bottom edge of each hole will be exactly on a radius, each radius being separated from its neighbour by an angle of 12 degrees. Then, in a direction concentric with the

errors are present, that is, an exact 12 degree radial spacing has not been made, then no matter how perfectly the holes are punched, distortion will be present. It can be recognized best when any article which has a straight edge is transmitted—say the top of a table. With an accurate disc it will appear as (A) of Fig. 2, but with a continuous and progressive angular error, the table-top will appear inclined or lop-sided, as in (B). If three or four holes have incorrect angular spacing, then the edge will be jagged, as in (C), or if a face was being shown, perhaps the eyebrow or the lip would be "lifted" out of place, and with a very bad disc quite a grotesque effect is noticed.

### Underlapping

Bad radial spacing, that is in the direction of the radii when the inside and the outside edges of succeeding holes are not in line, is evidenced by the presence of continuous black or white lines which appear vertically when the disc is run up to its correct speed, irrespective of whether any signal is being applied to the light source. This particular fault is known as underlapping or overlapping and is indicated in (D) of Fig. 2. When two successive holes overlap, the track made by the inner edge of the first hole is inside the track made by the outer edge of the next hole and thus a white line appears. On the other hand, when the track made by the inner

edge of a hole does not reach the track made by the outer edge of its following hole, it produces the condition known as underlapping. The result is an unpleasant black line running from the top to the bottom of the picture, the width of the line depending upon the magnitude of the underlap existing between these two consecutive disc holes. Skilful blocking and refiling will erase these faults when the errors are small, otherwise nothing short of a new disc will remedy matters.

### Source of Illumination

Comes now the third item. In order to be visible our image must be built up from some form of light source. This

Fig. 1 (below).—The method in which the holes in the disc should align themselves to obtain a clean picture.

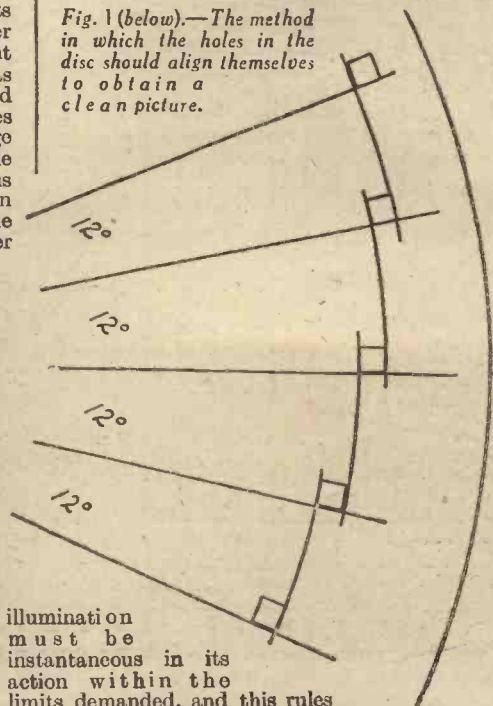

illumination must be instantaneous in its action within the limits demanded, and this rules out many forms for the same  
(Continued on page 746.)

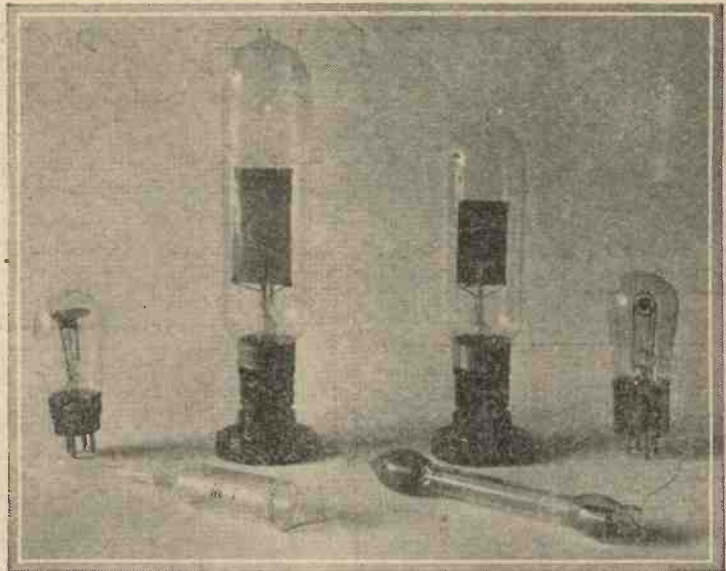

A group of neon lamps all of which have some particular purpose for television reception.

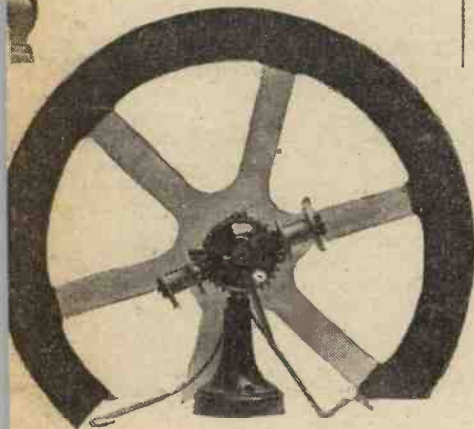

Illustrating the "fimsy" character of an ordinary television screening disc used at the receiving end.

circumference, or outside edge of the disc, the inside edge of one hole will be on the same arc as the outside edge of the following hole, as shown in the rough diagram of Fig. 1. Each hole is square-shaped and very small, but we need not worry about how the hole size is calculated; that can be deferred until a later date. Unless the apertures conform to this standard, a faulty disc will result, and this can be most disconcerting and, furthermore, many people fail to recognize that the distorted image is brought about by this mechanical trouble. For example, if angular

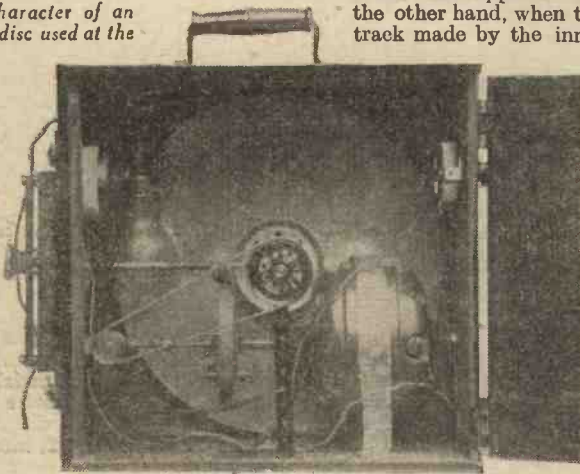

An amateur effort in television receiving apparatus showing the disc and neon lamp together with the motor driving the disc through a belt and gearing.

# Receivers and their Records

We shall be glad to advise readers regarding purchase of complete sets

If you glance at a list of mains-fed wireless receivers you will notice at once how few are made for D.C. as against A.C. mains; yet, although in a number of districts the generating stations have changed over, there still exist many towns, and areas, to which direct current alone is supplied. It is to meet such requirements that many makers have realised that in their range a D.C. mains receiver must be included, and for this reason special valves and components have been designed to render the construction of such sets a practical proposition. To-day, in some respects, the D.C. man is almost as well catered for as his A.C. colleague. The Gecophone "Nomad" four-valve receiver has been put on the market to fill a long-felt want, namely, a safe and competitive instrument of sound design at a reasonable price. With the new Osram indirectly heated valves, a high standard of efficiency has been obtained, and results are to-day comparable to those secured with receivers fed by A.C. mains. In addition, running costs are very small; the consumption current has been kept down to the neighbourhood of 70 watts, which represents roughly a fifteen hours working at a cost of one unit of electricity. The *Nomad* receiver takes the form of a four-valve

## GECOPHONE NOMAD FOUR-VALVE RECEIVER (D.C. MODEL)

table model with built-in moving coil loud-speaker; the cabinet is of polished inlaid walnut—a well-made piece of furniture—with all controls situated in front. To ensure good selectivity there are three tuned circuits employing two high-frequency stages feeding a screen-grid detector. The aerial is loosely coupled to the first grid circuit, and transformer coupling has been adopted throughout. The screen-grid detector in its turn is resistance-capacity transformer coupled to the DPT pentode output valve, which feeds a new model G.E.C. moving coil loud-speaker. Thoroughly efficient means have been taken to make the receiver perfectly safe, even in the hands of the raw beginner; there is no risk of an electric shock. The entire chassis on which the components have been built up is adequately earthed, and, in order to reduce mains hum to a minimum, the detector stage is separately screened, within the outer general screen, and thus also brought to earth potential.

The voltage range is 200-260 volts, the terminal board being arranged for three tapings to meet individual requirements, namely, 200-220; 220-240 and 240-260 volts. It is, therefore, only necessary to change one lead on this board to suit your mains.

The valves employed are Osram DSB screen grid in the second H.F. detector and first L.F. stages, a D.S. screen grid in the second H.F. stage, and an Osram DPT power pentode for output to the speaker. All valves except the last one are of the latest metallised

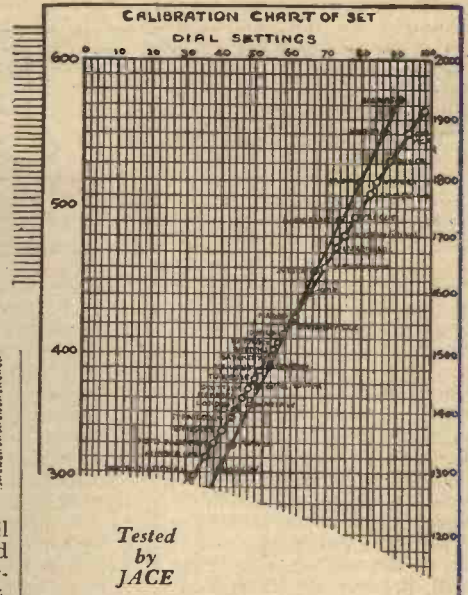

Tested  
by  
JACE

pattern. They are run in series (being indirectly heated with 16 volt heaters) and a 210 volt 75 watt pearl gas filled lamp is used to drop the supply voltage by the required amount. One ampere protective fuses are incorporated in the set, and the connection to the mains is carried out by means of a specially safe two-pin plug.

As may be seen from the illustration, all the controls are on the front panel. The central knob acts as tuner, and operates a triple gang condenser. The dial aperture immediately above is illuminated by the voltage dropping lamp, and, in consequence, shows at once whether the receiver is switched on or not. The right-hand knob combines the functions of "on" and "off" mains switch and volume control. It is of a novel pattern, inasmuch as it works a series aerial and reaction condenser. It works very smoothly and greatly assists in the tuning-in of distant transmissions. The left-hand knob serves a triple purpose as, according to its position, it enables the receiver to work on medium or long waves, and in addition puts the set right for the electrical reproduction of gramophone records. The two wavelength ranges are 230-550 metres and 1,000-2,000 metres, and the illuminated dial is very accurately calibrated in this manner.

Beneath the central knob is a local-distant switch, of which the use is advised for the reception of powerful local transmissions. By this means the overloading of valves is avoided; strength of signal is considerably reduced, yet may be increased as desired, by bringing the volume control into action. Three aerial connections are provided at the back of the cabinet. Where the receiver is installed within a few miles of the local station, in most instances reception on the plate aerial alone will give sufficient volume. This device, of course, detracts considerably from the efficiency of the circuit, but may be found useful in certain circumstances. Where an outdoor aerial is used, socket 1 is the normal and more sensitive position for the capture of distant transmissions, whilst aerial socket 2, incorporating a very small series condenser, enhances selectivity, and will assist in separating broadcasts on neighbouring channels. Generally speaking, owing to the high sensitivity of the *Nomad* circuit, it is advisable to adopt a reasonably short aerial if selectivity



The splendid finish and design of the Gecophone *Nomad* 4-valve D.C. model is apparent from this illustration.

is desired. On the other hand where a long aerial has been erected, in most instances socket 2 will be a necessity. Provision has been made at the back of the receiver for the use of a pick-up, but as the volume control is ineffective, in this case, an external potentiometer is recommended, and with the combined switch set to "gramophone," radio interference is automatically eliminated. When not in use the pick-up may remain connected to the set without causing any inconvenience.

On test, the *Nomad* showed a remarkable degree of sensitivity, and in this respect gave superior results to any previous four-valve set made by these makers. The receiver was very quiet in operation; the decoupling of the circuit and smoothing were found to be adequate, as the method adopted prevents any perceptible mains hum. Both for radio and for gramophone records the reproduction from the speaker was thoroughly satisfactory. It is an entirely new production in which the input transformer is fitted in the loud-speaker chassis itself, the field winding being run in series with the heaters of the valves. Although

covering a good tonal range, the bass is free from any boom, and speech is natural, providing volume has not been pushed to an extreme limit. In the anode circuit of the pentode valve a well-designed heterodyne filter eliminates the objectionable 9,000-cycle whistle without affecting the quality of the tone. The undistorted output is ample for all ordinary requirements; it reaches almost 1 watt, and consequently volume is such that on most transmissions signals will fill a large-sized room. Using a 35-40ft. aerial in a north-western district of London, the *Nomad* proved its efficiency by capturing transmissions from a number of European stations on the medium waveband during daylight hours. Broadcasts from the B.B.C. National and Regional stations, and from Fécamp, Poste Parisien, Leipzig, Langenberg, Brussels, Munich, were well heard; on the long waves, Huizen, Radio-Paris, and Warsaw were also logged. During the evening a larger number of transmitters was logged. These included more distant stations such as Lahti and Reykjavik (when Radio-Paris had closed

down); also Motala, Kalundborg, Oslo and Leningrad (on its own wavelength). With some patient manipulation of the controls it was found possible to separate Königs Wusterhausen from Daventry and Eiffel Tower from Warsaw; but no difficulty was experienced in getting Brussels clear of Florence, and in securing good reception of Rome, Stockholm, Sottens, Midland Regional, and, at times, Mühlacker. On the lower waveband some of the smaller stations gave sufficiently loud signals to be of entertainment value. For the reception of the London Regional and National broadcasts use of the plate aerial was indicated, to prevent valve overload, and with volume reduced there was no sign of distortion. The test showed that the *Nomad* is capable of giving its owner a variety of alternative entertainments, and its over-all performance reflects great credit on its designer. Its outstanding qualities are ease of control, high selectivity, good reproduction, economy of upkeep, and notable absence of mains hum.

I HAVE just completed a test of the new *Six-Sixty* type 3-32 chassis set. This is a receiver of the console type, mounted in a handsome walnut cabinet, the fret of which is of a striking conventional pattern. On the front of the panel there is an oxidized metal dial of a unique design in which a plaque is fitted, dividing the short and long-wave stations. The outer section of this dial gives the names of fifty-two European stations, and the inner section thirteen stations, the former being short-wave and the latter long. In addition to the usual 100 degree dial reading, the wavelength and kilocycle of each station is

A NEW RECEIVER

mentioned. The interesting part of this system of tuning is, when the set is switched on to either long wave or short wave the dial is lighted by a beam of light from behind pointing on the chosen station. It is one of the best systems of tuning for the person who has no time for knob-twiddling that I have as yet come across. Its simplicity is simply amazing. The circuit comprises "Pre-Selector," band-

pass tuning, screened grid, detector, and pentode output. Automatic grid bias is provided, and also regulating resistances. The tuning is knife-edged, and the reproduction is what we expect when a Celestion permanent-magnet moving coil is used. This year the majority of manufacturers have paid more attention to mains-driven receivers to the detriment of those battery-operated, and it is quite delightful to handle a battery set such as this which will be assured of a welcome by those people who are looking for a new set, and are unable to take advantage of the electric mains.

JACE.

*This* WEARITE HETERODYNE FILTER UNIT means MUSH-FREE PROGRAMMES

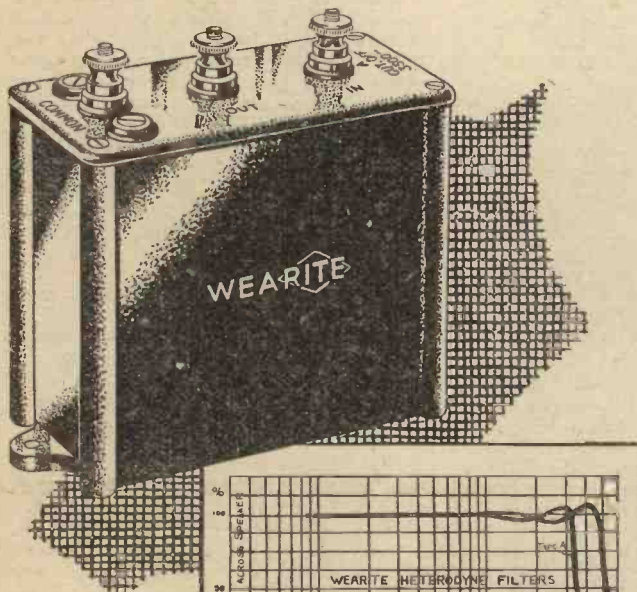

THE more sensitive your receiver the more prone is it to heterodyne whistle interference—and the greater the need for this Wearite Whistle Filter. With a host of really good programmes always available, there is now no need to have distant reception marred by this interference. This Wearite Unit is made in two types. 'A' to cut off at 3,500 cycles for normal use, and 'B' calling off at 5,000 cycles for the music critic. With it only the programmes reach your speaker—the Wearite Filter is a barrier to heterodyne whistle. **10/6** Will fit any Set. Write for special leaflet. **BOTH TYPES**

The graph shows the characteristics of the two types of Wearite Heterodyne Filters.

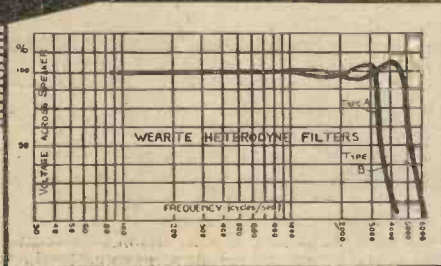

**WEARITE**

**WRIGHT & WEARE Ltd.,**  
740. HIGH ROAD, TOTTENHAM N.17.  
Tel.: Tottenham 384718/9

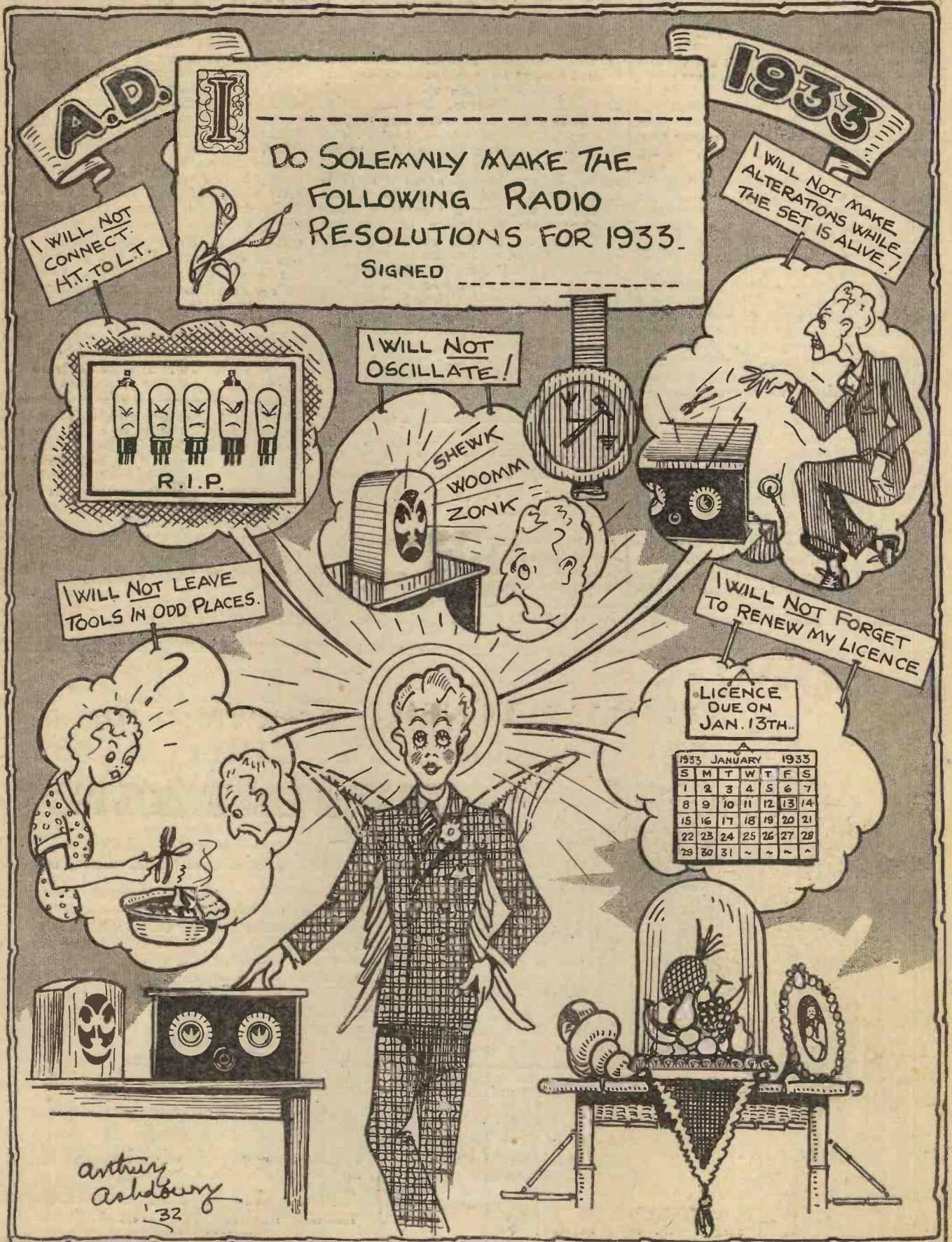



# STAGGERING OFFER TO HOME RADIO CONSTRUCTORS

**AMAZING 84/- SET for 3**

## THE FAMOUS SLEKTUN SCOUT S.G.3 "50 Stations" KIT

At a GREAT REDUCTION for Xmas

The famous "Slektun" Scout Screened Grid 3-valve Kit Receiver, already built by thousands of enthusiastic constructors all over the country and formerly sold at 84/- is now offered to YOU for 23.

The Cabaret Electric Co., Ltd., to commemorate the opening of a magnificent new branch at 182, Vauxhall Bridge Road, are able to make you this amazing offer for a limited period only, having purchased a huge quantity. Earliest application for one of these splendid kits is strongly advised.

Every kit includes the exact components originally specified by the designer, and is supplied complete with baseboard and ebonite panel cut to size and ready drilled, together with all necessary terminals, wire and flex, full-size blue-print and illustrated construction guide.



### COMPLETE KIT

Includes the famous Slektun Super Transformer, Slektun Dual Range Coils, Cyldon Ganged Condenser with Sector Vision Escutcheon, T.C.C. Fixed Condensers, W.B. Valve Holders and Switches, Ready Drilled Panel and Terminal Strip of "Permol" non-discolorable Ebonite, Baseboard Assembly covered with "Konductite" metallic screening material. All necessary screws, terminals, connecting wire, wander plugs and flex.

Don't miss this wonderful opportunity of securing the finest kit set of the year at a price which cannot be repeated after our present stocks are exhausted.

**CABARET ELECTRIC COMPANY, LTD.**  
182, VAUXHALL BRIDGE ROAD, LONDON, S.W.1  
and 238, High Road, Lewisham, S.E.13

★ Write for fully descriptive folder.

# CLIX FOR PERFECT CONTACT

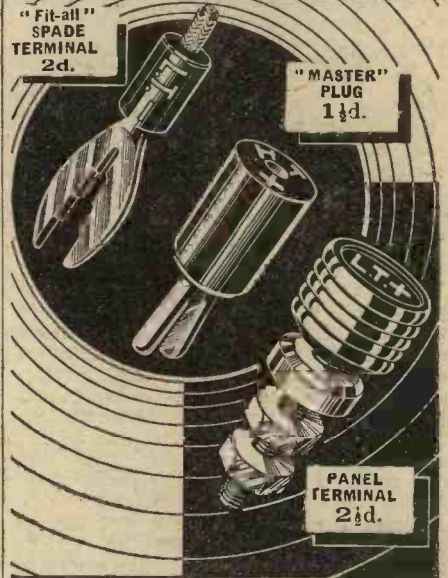

### To ensure perfect contact, Clix were SPECIFIED for the SUPERHETERODYNE CONVERTOR

Clix supplies the finest range of Contact components in existence. Write now for Folder "N," giving details of over 23 components necessary for efficient contact. Free on request. Lectro Linx Ltd., 254, Vauxhall Bridge Rd., S.W.1

# AUTOKOIL

## ALL-WAVE TUNER—Specified for the

"Autokoil"

# PENTODE TWO

An inexpensive yet selective, powerful and highly efficient receiver with an exceptionally wide range of tuning.

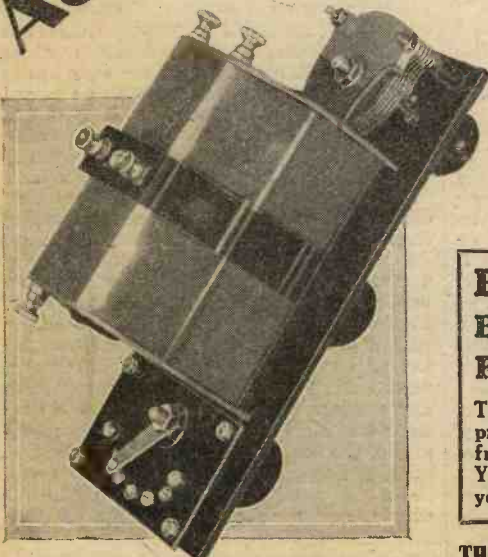

Illustration shows "Autokoil" all-wave tuner with variable reaction coil, compensating condenser and five-way selector switch, complete.

Price 12/6 complete.

Descriptive Leaflet "P.W." and Circuit Free.

Telephone: **A. W. HAMBLING & CO., LTD.,**  
Museum 7651. 16, ALFRED PLACE, LONDON, W.C.1

### FULL SIZE BLUEPRINT FREE with every KIT

This full size 1/- Blueprint is only obtainable from A. W. HAMBLING. You can get a copy sent you post free for 9d. only.

**THERE IS NO SUBSTITUTE FOR THE "AUTOKOIL" TUNER.** Covers 200 to 2,000 metres.

### GUARANTEED KIT OF PARTS.

1	Autokoil All-wave Tuner (Hambling)	12 6
1	.0005 Variable Condenser (Polar No. 2)	6 6
1	.0003 Fixed Condenser (T.C.C.)	1 3
1	.002 " " (T.C.C.)	1 6
1	.0005 " " (T.C.C.)	1 3
1	.01 " " (T.C.C.)	3 0
2	1 " " (T.C.C.) @ 2/10 ea.	5 8
1	2 Meg Leak	10
1	Bias Resistance 500 Ohms (Wattmel)	1 0
1	Resistance 5,000 Ohms (Varley)	1 6
1	" " 25,000 " (Varley)	1 6
2	Valve Holders 1-4 pin, 1-5 pin (W.B.)	1 8
1	L.F. Transformer 7-1 (R.I.)	10 6
1	Fuse and Holder (Bulgin)	1 6
8	Terminals (Clix)	1 8
1	Terminal Strip, 12in. x 1 1/2in.	1 6
1	Pair Panel Brackets (Bulgin)	1 3
1	Switch (Bulgin S 35)	1 0
1	"Autokoil" Escutcheon plate (Hambling)	1 0

CASH PRICE £217 4

KIT Terms—Carriage Paid on all retail orders. C.O.D. charges paid on orders over £1. Easy payment terms arranged, if desired.

Accessories extra.

1 Cabinet 16/6 (Clarion). 1 Det. Valve 7/- (Cossor).  
1 Pentode Valve 17/6. (Cossor). 1 I.T. Battery, 120v., 16/9. 1 L.T. Accumulator, 2v., 4/6.



# OUR SHORT-WAVE SECTION



**M**ODERN circuit development has led to the production of short-wave receivers which are greatly improved, and which give results far ahead of those obtained with less efficient apparatus a few years ago. The home constructor now chooses the circuit best suited to his requirements, purchases a kit of parts as specified by the designer, assembles and wires them up as laid down in the constructional article, and finds, when all is coupled up and the set switched on, that the performance leaves nothing to be desired. There are, however, a number of home constructors unable or unwilling to face the expense necessary in order to purchase a complete author's kit of components, or who desire to use others of different make which they already have to hand. There is a certain element of risk in the adoption of this form of procedure, but in some cases it is unavoidable, owing to circumstances which allow no choice other than doing without a short-wave receiver altogether.

The experienced constructor goes straight ahead and finds that when the receiver is given an aerial test everything is satisfactory. If some obscure trouble is experienced, he knows how to trace it, and, when cured, settles down to search around the short-wave bands. The beginner, under similar circumstances, is a little bewildered, and after a frantic endeavour to overcome the trouble, calls to his aid a more experienced fellow enthusiast, who soon puts things right.

There are, however, many enthusiasts who carry on alone owing to being unacquainted with others sharing the common interest. It is safe to say that the troubles met with under the foregoing circumstances may be listed under the following headings: Body capacity effects; threshold howl; dead spots. The reader who is troubled by any one of these will not wish to read a detailed description of each and all. Probably, owing to experience, and information obtained from other sources, he is fully acquainted with them and knows exactly the kind of trouble he is up against. Under the circumstances, the information he will appreciate is, how to overcome and get rid of the trouble. In order to assist him, I give the following list of experiments which may be tried individually until one is found which definitely overcomes the particular trouble experienced.

#### Body Capacity Effects

A metal panel or sub-panel earthed from a number of different points of its surface owing to the difference of potential at various parts of the screen.

A screen of aluminium, or copper, either sheet or foil under the baseboard to which all leads to earth are taken direct by means of small bolts placed at the nearest point

### SHORT-WAVE RECEIVER TROUBLES AND HOW TO OVERCOME THEM

By ALF. W. MANN

to the component from which the lead to earth is taken. This shortens the wiring, thus increasing the efficiency of the circuit.

Place a 50 turn choke of 30 d.c.c. wire, wound on a lin. former in each 'phone lead. If this has no effect, place a small fixed condenser across 'phone terminals. Slacken the coupling between the aerial and grid coil. If the coupling between these coils is too tight, instability, hand capacity, and, in some cases, threshold howl will result. If a variable capacity condenser is used in series with the aerial as a coupling condenser, reduce the capacity by adjusting same so that moving plates are full out.

#### Interaction

Test for interaction due to magnetic fields between coils, choke, or screens by holding a piece of copper or aluminium sheet between the suspected components. This in effect will by-pass stray H.F. currents to earth, and gives an idea as to where interaction is taking place. The receiver should be tuned to a powerful signal, preferably on the broadcast band, in order to carry out this useful experiment.

#### Dead Spots

A .0001 mfd. fixed condenser placed in series with the aerial will often remove the dead spot to another part of the tuning range. Before trying this, slacken the coupling between grid and aerial coil, or aerial coupling condenser. This trouble is due to the natural wavelength of the aerial falling within the tuning range of the receiver. Providing the most suitable length of aerial can be found by experiment, this trouble can be completely obliterated.

#### Threshold or Fringe Howl

If transformer coupling is used in the L.F. stages, remove each in turn, and substitute with another make. Place an H.F. choke in series with the grid of L.F. valves and transformer secondary.

Decouple H.T. battery by means of a 2 mfd. fixed condenser, and a wire-wound resistance of 25,000-30,000 ohms; a resistance of less than 20,000 ohms should not be used.

If two transformers are used for L.F. amplification, replace one with an R.C.C. unit. Immediately this will assist stability.

and freedom from background noises, mush, etc.

Reverse leads of L.F. transformers. Another method, which is, however, a little expensive, is to place a 600-ohm resistance (spaghetti) in series with each H.T. lead, also L.T. and G.B. leads. A 2 mfd. fixed condenser is then connected to the receiver end of each resistance, and the remaining terminal of the 2 mfd. condensers to earth.

### MAKING SHORT-WAVE COILS

**V**ERY good short-wave coils can be made with the aid of a bottle.

Obtain a length of the brown adhesive paper which is now used by the shops for sealing parcels. This should have a width of 1½ ins. or 2 ins. Cut off a strip which will just go round a bottle having a diameter of about 3 ins. Wrap this round the bottle, with the sticky side outwards, and stick down the end. Allow it to dry thoroughly. Now obtain some thick D.C.C. wire, say No. 18 or 20 gauge. Thoroughly moisten the paper, and wind the wire on tightly. It is best to make a set of these coils, having 2, 4, 6, 8, 10 turns, and so on. Leave a space between adjacent turns equal to the thickness of the wire. When the coil is finished it should be held in position while the cotton covering of the wire firmly sticks to the paper. The ends of the coil may be anchored by smaller strips of the same paper. It should be possible to slide the completed coil off the bottle, when it will be found to remain quite solid and firm. If, however, through some fault or other it will not slide off, instead of undoing the coil the bottle may be broken carefully, leaving the coil intact. In America there is a brand of pickles sold in an eight-sided bottle, and this makes a splendid former. It may be possible to obtain something similar in different parts of this country, so the particular shape is worth bearing in mind. The finished coil may be mounted in any manner to suit the taste of the constructor. The following table gives a rough idea of the tuning range of these short-wave coils, although it is possible that they will be slightly modified by the particular wiring, and type of components in each individual set.

2 turns with .0003 tuning condenser, from 20-30 metres
4 " " .0003 " " " 30-50 "
6 " " .0003 " " " 45-60 "
8 " " .0003 " " " 60-80 "
10 " " .0003 " " " 70-100 "

KEEP YOUR DATA SHEETS IN OUR SELF-BINDER. See page 727.



# The BEGINNER'S SUPPLEMENT

Conducted by  
F. J. CAMM

**T**HERE is no doubt that for economy and reliability there is nothing to approach the humble crystal set, and for those who are tackling home construction for the first time it is the ideal type of receiver to build. Of course, you cannot expect to work a loud-speaker unless you employ some form of amplifier, but if you are content with headphones you will find a crystal set will provide exceedingly clear reception for a very modest outlay and will entail no running expenses beyond the annual licence fee. The receiver illustrated here is particularly easy to construct, but at the same

## THE BEGINNER'S CRYSTAL SET

Anyone can make this efficient little set in an hour or two. Although specially designed with a view to easy construction it is not a toy. It has a means for varying the selectivity and will separate Regional and National programmes.

Designed by W. B. RICHARDSON.

two small holes. Through these two holes thread the end of the wire. This is to secure it in position. Leave a few inches of wire over for making connections. It is better to have this come through the inside of the tube as it will make a neater job when it comes to making the connections to the terminals. Having secured the wire, commence to wind the coil, keeping the turns as close and even as possible. When you have wound on 15 turns pierce two more holes close to the last turn you put on and making the wire into a loop about four or five inches long, pass it through the holes, as you did the single wire at the beginning, and pull it tight. You should pass it first through one hole to the inside of the tube, then to the outside through the other little hole, and finally back to the inside

### Making the Coil

It is perhaps best to start by making the coil. By this we mean the medium-wave coil which is shown with the three terminals on top. For the benefit of those whose most powerful station is the National on the long-waves, provision is made for a long-wave coil as well. This one, however, is not home-made, but is of the plug-in type.

The coil you have to construct is wound on a paxolin or treated cardboard former, and contains 65 turns of No. 22 gauge double cotton-covered wire. The former is 3in. in diameter and 4in. long. Start about 1/2in. or 1in. from one end, and pierce

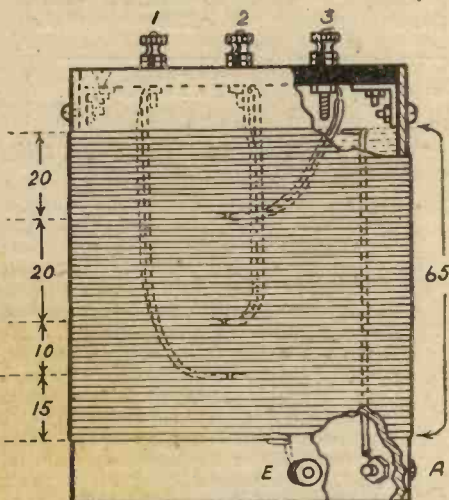

USE 22 GAUGE D.C.C. WIRE

Fig. 1.—Details of the Tuning Coil.

time is very efficient. It is designed to meet varying conditions so that it will work well on different aerials, and in various parts of the country. This is achieved with the aid of the special coil. It has three tappings and by means of two flexible leads different settings can be tried, and so the best position as regards selectivity and signal strength may soon be found.

### No Soldering

If you examine the illustrations you will see the general lay-out of the set. It is perfectly straightforward, there being no awkward wiring and no soldered connections are necessary. The components are mounted on the usual panel and baseboard. The former may be of ebonite or wood, and measures 6in. by 6in., whereas the latter is of 3/4in. ply wood 7in. by 6in. Panel and baseboard may be joined together with small screws, as shown or panel brackets can be employed.

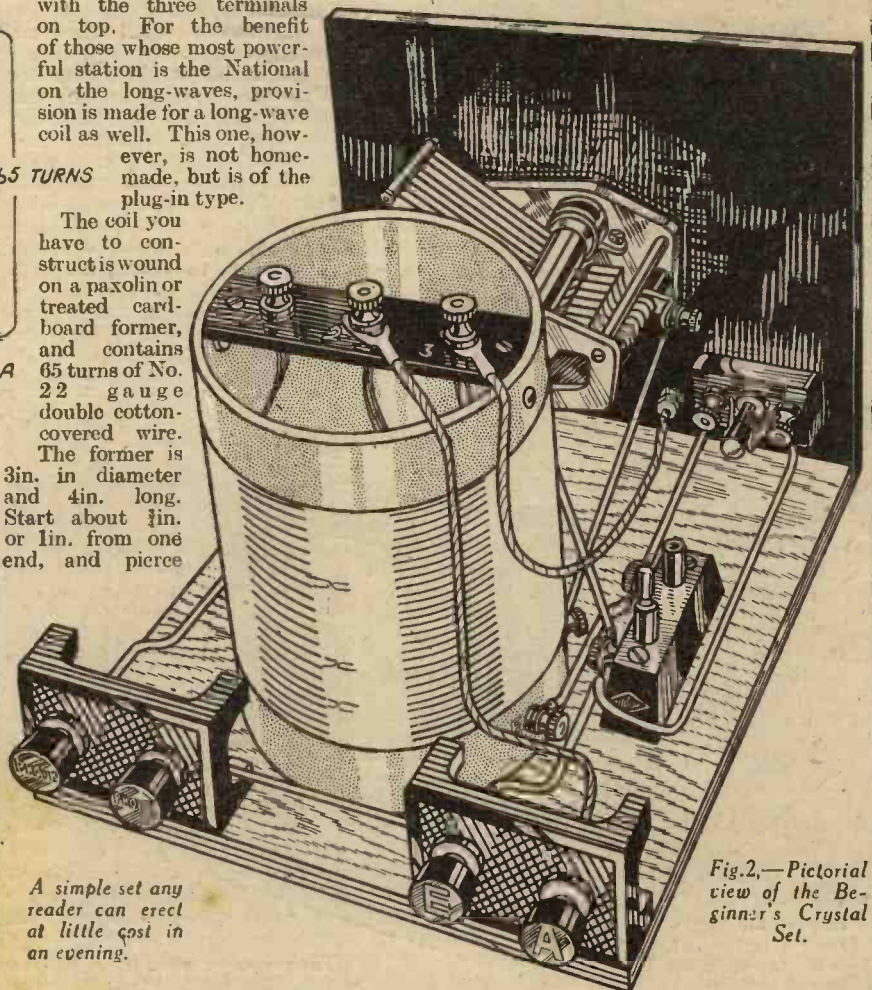

Fig. 2.—Pictorial view of the Beginner's Crystal Set.

A simple set any reader can erect at little cost in an evening.

through the first hole. This should leave you with a loop of wire coming through to the inside about four or five inches long. This loop will form one of the windings, and will finally be fixed to terminal No. 1 on the top of the coil. (See Fig. 1.) Do not do anything with it for the moment, however, but continue with the winding. Put on another 10 turns, winding in the same direction as the first 15 turns, and make another loop like the first one. Now wind on 20 turns, and make the third and final loop. This also is brought through to the inside. The last lap in the winding consists of another 20 turns, when you should finish off by cutting off the end of the wire with just enough to spare to thread through two holes, and leave a short length for connections. The coil will thus consist of a total of 65 turns.

The next job is to mount the terminals on the coil. To fix the two lower ones, marked A and E on Fig. 1, you simply drill two holes in the tube itself. Before tightening them up they must be connected to the two ends of the coil. The cotton covering is scraped from the connecting wire at the lower end of the coil, and secured under the fixing nut of terminal E while the upper end of the coil is connected in the same way to terminal A. To support the top three terminals, a small strip of ebonite is used as shown. It is wedged in the top of the coil and held in place with two small "Trix" or "Meccano" brackets. The three loops of wire from the inside of the coil are each cut at the end, scraped bare, and secured under the three terminals as in Fig. 1.

**Mounting the Parts**

The coil is now complete, and it should be mounted on the baseboard with the coil holder and terminal mounts. Figs. 2 and 3 will show their positions. It should be noted that the coil should be well to the back of the baseboard so as not to foul the variable condenser which is mounted

on the panel. An easy way to fix it to the baseboard is to glue a strip of wood inside the lower end like the ebonite terminal strip at the top and to screw this to the baseboard.

**Wiring Up**

On the panel you have to mount the variable condenser, the crystal detector, and the wave-change switch. If you drill the hole for the spindle of the condenser a little above the exact centre of the panel there will be room for the detector below it, as shown. The type of detector illustrated is preferred by the writer to any other. It contains one of the galena type of crystals such as "Hertzite" and contact is made with a cat's whisker. Provided a little care is taken to find a good spot on the crystal, and the whisker is adjusted to rest on it with the right pressure results are excellent. Of course, there is no reason why you should not use one of the semi-permanent types if you prefer, but although less tricky to handle they are not usually so sensitive.

The receiver is completed by screwing the panel and baseboard together, and wiring up. Actually it is easier to fix some of the wires before the panel is fixed as it gives you a little more room to work. With the exception of the two flexible leads all the connections are made with insulated connecting wire such as Glazite. The two flexible leads are made of ordinary lighting flex with spade terminal tags

clipped on one end to facilitate connection to the coil terminals. Fig. 3 will make the wiring quite clear.

**The Cabinet**

No doubt when you have made the receiver you will want a case for it. If you are at all handy with tools you will be able to make the one shown. As you see, it provides room for the set itself and also an additional compartment for the 'phones. This makes a very compact affair of the whole thing. There is nothing difficult about the construction. It is made of 3/4 in. mahogany or oak. Or again deal stained to represent either of these woods can be used. The bottom is finished off with a base moulding made by Hobbies, Ltd. It can be obtained in oak or hazel pine (Reference No. 41). It should be mitred together at the corners like a picture frame.

**Operating Hints**

Now for the try out! Connect up the 'phones (4,000 ohms for preference). Join on the aerial and earth, and pull out the wave-change switch. Before adjusting the crystal connect the two flexible leads to the terminals on top of the coil. Try first of all with the one from the crystal detector joined to No. 3, and the one from the aerial to No. 2. Then listen in by turning the tuning knob slowly

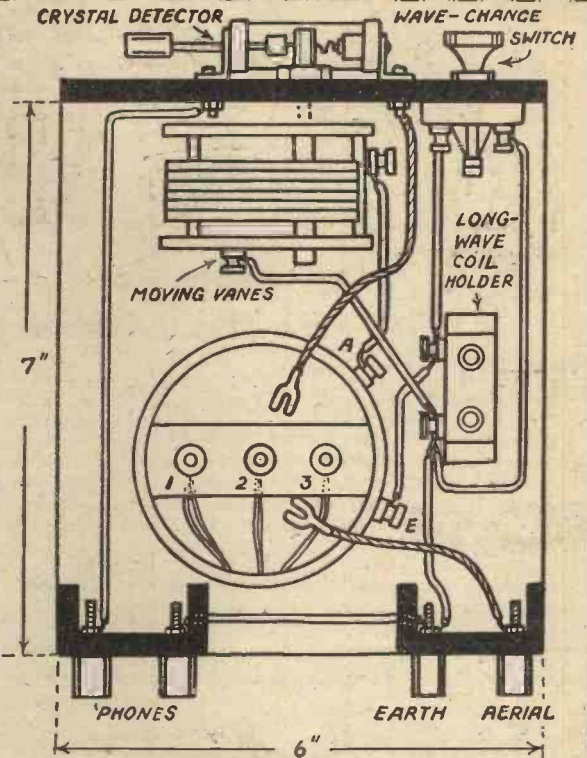

Fig. 3.—Wiring diagram of the Beginner's Crystal Set.

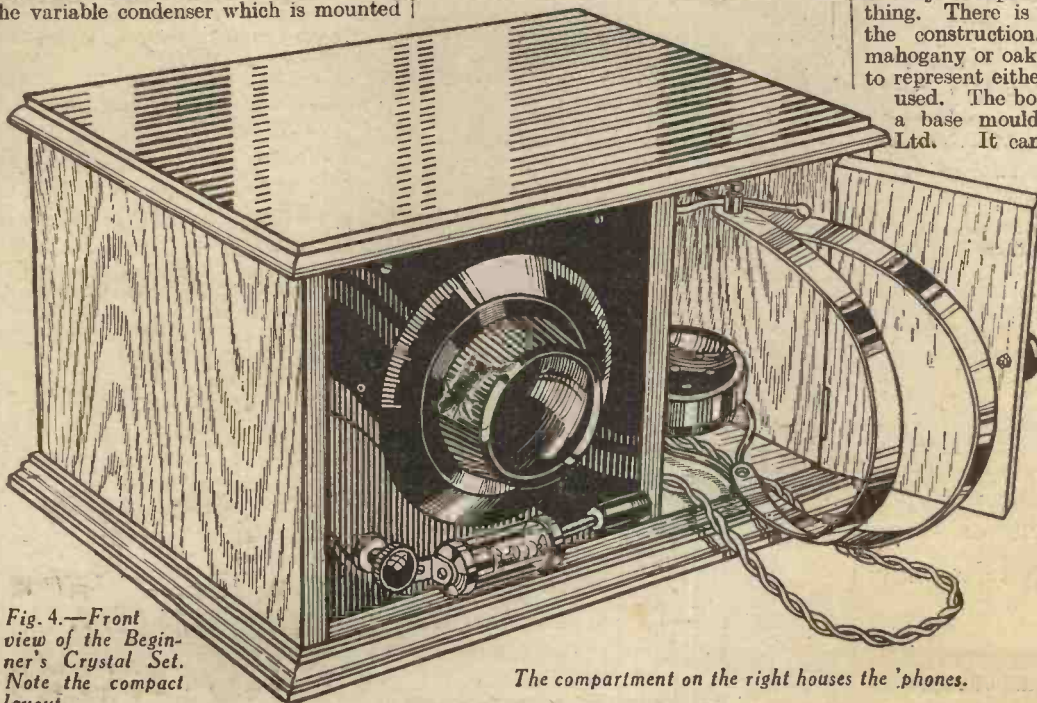

Fig. 4.—Front view of the Beginner's Crystal Set. Note the compact layout.

The compartment on the right houses the 'phones.

**Just plug in!**

**RADIO IN EVERY ROOM**

You can easily extend your wireless to every room in the house by means of these handsome fittings. They cannot be confused with your heating or lighting points.

**BULGIN MIDGET WALL JACKS**, all insulated. Walnut or Mahogany bakelite finish.

**BULGIN JUNIOR WALL JACKS** in black or brown bakelite with nickel plated cover.

STANDARD TYPE JACK PLUGS, AS ABOVE, 1/6

THEY COST 1/6 PER POINT.

2/- PER POINT.

OBTAINABLE FROM ALL DEALERS.

Full instructions for wiring given in our 80 p. Catalogue "N." Send for your copy now. Enclose 2d. postage.

**BULGIN**  
*The Choice of Critics*

A. F. BULGIN & CO., LTD.,  
RADIO MANUFACTURERS,  
TELEPHONE: GRANGWOOD 3266/7.

ABBAY ROAD,  
BARKING, ESSEX.

**THE FIRST CHOICE ALWAYS at either Price**

**AERIAL**

(Patent)

**TYPE B**  
No. 1001

**TYPE R** 2 1/2  
No. 1003

(Patent) TYPE "B" Non-rotating name. Extra large clamping area. Cross-hole for solid tags or wire. Slot and nut to eliminate soldering.

TYPE "R" Non-removable rotating head.

Write for "Radio Connections" post free.

**BELLING-LEE TERMINALS**

Advert. of Belling & Lee, Ltd., Cambridge Arterial Road, Enfield, Mdx.

**GET THIS NEW BOOK**

**IT TELLS YOU ALL ABOUT**

**RADIO POWER UNITS**—and how to build them..

**NOTES ON A.C. POWER UNITS.**

**OPERATING RECEIVERS ON D.C. MAINS.**

**ABOUT T.C.C. ELECTROLYTIC CONDENSERS.**

**ELIMINATION OF INTERFERENCE.**

**FOUR T.C.C. POWER UNITS** with full constructional Details.

**ROTATING RESISTANCE CALCULATOR.**

**THE DESIGN AND CONSTRUCTION OF RADIO POWER UNITS**  
T.C.C.

PACKED full of real useful information and data, this T.C.C. Booklet shows you how to run your set off the electric light (A.C. Supply)—It shows you how, once and for all, to cut the cost of expensive batteries, and to get better radio. With a chapter on D.C. mains apparatus, this book should be in every electric light users hands. Get your copy now!

**COUPON**

To Publicity Dept., The Telegraph Condenser Co., Ltd., Wales Farm Road, N. Acton, London, W.3.

Please send me a copy of your book "The Design and Construction of Radio Power Units," for which I enclose six penny stamps to cover cost and postage.

Name.....

Address.....

1 Dec. 31/12/32

Please write in Block Letters

**Ask your Dealer**

If you have any difficulty in obtaining a copy of this book. Fill in the coupon and post to us with six penny stamps. We will send you a copy by return.

**T.C.C.**  
**ALL-BRITISH**  
**CONDENSERS**

2102

round and trying various settings of the crystal. Having discovered a sensitive point on the crystal, leave it alone, and concentrate on the tuning. If it is not sharp enough, and you can hear two stations at once take the aerial tapping to No. 1 terminal instead of No. 2. If, on the other hand, there is no appreciable overlap, try both aerial and crystal lead on terminal No. 3. This will make the signals somewhat louder, but not so sharp as regards tuning. Still another arrangement is to leave the lead from the detector joined to No. 3, and to connect the aerial lead to terminal "A" on the bottom of the coil. Usually, this position gives the loudest signals, and the flattest tuning. Don't forget that each time you alter the connection of the aerial lead you alter the setting on the tuning condenser so that you will have to readjust that as well. For instance, if a station tunes in at 50 deg. on the dial with the aerial on No. 2 terminal you will find that on moving the aerial to No. 3 you will have to tune lower for the same station, probably about 30 deg.

The best thing is to experiment until you get the most suitable combination

#### LIST OF COMPONENTS.

- One J.B. popular variable condenser, .0005 mfd.
  - One Becol ebonite panel, 6in. by 6in.
  - One baseboard, 7in. by 6in.
  - One Paxolin or card former, 3in. diam., and 4in. long.
  - Half oz. 22 s.w.g. D.C.C. wire.
  - One small strip of ebonite 3in. by 1in. by 1/4in.
  - Two small Clix brackets.
  - Four small nuts and bolts, screws, etc.
  - Five small terminals.
  - One crystal detector with Shaws "Hertzite" crystal.
  - One Bulgin coil-holder.
  - Two Belling-Lee terminal mounts.
  - Four Belling-Lee terminals—"Aerial," "Earth," "Phones."
  - One Ready Radio on-off switch.
  - One Hank Glazite connecting wire.
- ACCESSORIES.
- One pair Browns Featherweight Headphones.

for your particular aerial, and locality, and to leave it at that. You will find that the setting of the flex from the crystal will not have much effect on the tuning, but that one particular connection will give the loudest signals. This will probably be No. 3 terminal or terminal "A"—it depends on the resistance of the crystal and 'phones.

So far, no mention has been made of wave-changing. Well, to tune in to the long waves you plug in a Tunewell or Lewcos 175 or 200 coil. For listeners situated near London the National long-wave station is not usually as loud as either the London National or London Regional, and under these circumstances a long-wave coil is hardly necessary, since the National programme is always relayed by either London National or London Regional. However, for others the long-wave station is often the loudest, and it is these listeners who will profit most by buying a long-wave coil. After it is plugged-in, the switch does the rest. Just push it in for the long waves and pull it out for the short, there being no need to remove the coil each time.

## TESTING BY SHOCK

By  
A. E. OAKLEY

A QUICK way of testing L.F. transformers, chokes, and similar highly inductive apparatus which I have used for many years, is the "shock" method. It does not appear in the text-books, but is one of those little dodges which one develops in a varied electrical engineering experience, and I have often found it useful to check, for example, the right and wrong way round of dynamo field connections. For testing a transformer a few volts only are necessary. A flash lamp battery or 4-volt accumulator will answer, or a small section of the H.T. battery may be used.

Connect one terminal of the battery to a terminal of the winding, moisten two fingers of the left hand, and place one finger on each terminal. Now, with the right hand, flick the free battery lead on and off the free terminal quickly. A slight but quite definite shock

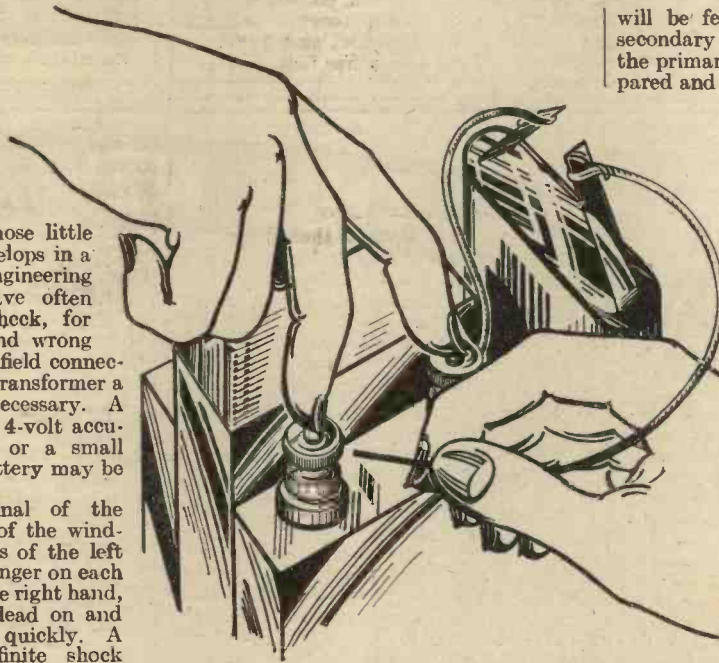

will be felt if the winding is O.K. The secondary will give a stronger shock than the primary, so the windings may be compared and identified if unknown. Suppose it is desired to use a transformer as L.F. choke, with the windings connected in series. How is one to know which terminals to connect together, seeing that the winding direction is unknown? Just connect one terminal of each winding together, and test the free terminals for shock. If the shock is appreciable, and greater than either winding gave alone, the connection is correct. If, on the other hand, the shock is nil or almost so, one end of the connection only must be changed over, because the windings are connected in opposition. Many applications of this method will suggest themselves to the ingenious experimenter.

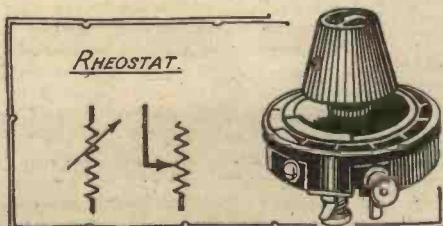

#### WIRELESS SHORTHAND No. 4

If you are a beginner, you should collect our Data Sheets. YOUR Self Binder for them awaits you.

See page 727.

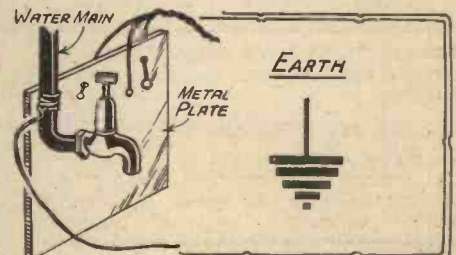

# RADIO RAMBLINGS

## Etherwave Organ Transmissions from Paris

**H**AVE you heard the electric organ of Poste Parisien during the test transmissions of this instrument? Broadcasts of this will now form a regular feature of the programmes from this station, since it was officially inaugurated on October 26th. The organ makes use of wireless waves for the production of music, and the effect is in many ways similar to the ever-popular cinema organ. Many have been the devices used on these organs for the production of different "effects," but, in my opinion, the ordinary pipe organ is still vastly superior in every way. Unfortunately, this instrument is a difficult one to broadcast, and the control engineer is always kept busy during a transmission of this nature. The large range of frequencies and the great volume range to be obtained from an organ mean constant control if the best results are to be obtained. The mighty volume of the diapasons needs curbing if listeners' speakers are not to "blast," and as often as not, in organ music, a mighty rush of sound is immediately followed by the sibilant whispering of the swell, which is missed completely by the listener unless the engineer handling the "knobs" is very alert. Microphone improvements have, however, much improved the transmission of the king of instruments, and reception is much better than used to be the case.

## U.S.A. and Sponsored Programmes

**A**MERICAN listeners are now getting heartily tired of sponsored programmes, especially those which comprise more talk by the sponsors than by actual music programme. An outcry against the length of time taken up by the advertisers' "sales talk" is sweeping the whole of the States, and it is beginning to be believed that the sponsor who simply announces his name and product will find the best results from so doing. Also from U.S.A. comes the demand for "one-man" sets, which would seem to be going back to crystal-set days. It is complained that rarely are two people sufficiently alike or psychologically in tune to be able to enjoy the same wireless programme. This may be so, but I don't think we on this side would care to go back to the days of headphones, bringing either headaches or sleepiness in their wake. It is a strange thing, too, that, no matter what invention comes along to bring brightness to human lives, there are sure to be some people to grumble at some of the aspects it presents.

## What We Owe to Bakelite

**A** NEW super-factory has been just opened by Messrs. E. K. Cole and Co., Ltd., the famous Southend makers of "Ekco" products. The way this firm has progressed in seven years, from a small room with a handful of workers to a gigantic factory employing some 3,000 hands, is

## JOTTINGS FROM MY NOTEBOOK. By "DETECTOR."

yet another of the miracles of radio. The history of this firm has, to a large extent, been the history of the development of the substance known as bakelite, and the new "Ekco" works is being devoted solely to the production of bakelite articles. What we radio amateurs owe to bakelite is not fully realized, for, in the old days, knobs and dials used to be carved from ebonite. Later, a method of moulding this substance commercially became known, but when the principles underlying the manufacture of bakelite were fully understood, and a technique regarding the special moulds necessary for the production of bakelite articles evolved, ebonite quickly took a back seat. Now, complete cabinets are moulded from bakelite, and hardly a component in our sets is free from bakelite in some form; it is safe to say that the use and development of bakelite has been one of the greatest factors in bringing radio within the means of the masses during a period of great depression.

## Music from Oscillating Valves

**Y**OU may have noticed that I have a weakness for telling you things about our cousins across the "herring pond," and I came across an interesting account of an invention from Philadelphia. This time, however, it is an invention of a Russian physicist who has developed another of those weird electrical instruments which produce sounds by means of oscillating valves or similar methods. This new instrument has sufficient novelties about it to warrant my mentioning it, the chief of which is that it is played by an ordinary keyboard somewhat like that of a piano. Almost endless possibilities are held out to the performers, however, for the volume is controlled by the extent the keys are depressed. A heavy-handed performer, therefore, would be guaranteed to raise the roof, or at the very least to so "blast" the loud-speaker, from which the sounds emit, as to seriously cause trouble with the neighbours. The inventor, however, had something of this in mind when he arranged a means of "silent practice" for learners of his instrument, for by a simple device the volume can be reduced and fed through headphones so that only the performers themselves are able to hear the result of their endeavours.

## "Soft" Valves

**I** CAME across a very rare thing the other day—a "blue-glowing" valve. It is not often that these are found nowadays because "blue-glowing" invariably implies

a state of "softness" in the valve. As you may know a hard valve is one that has a high degree of vacuum inside its glass bulb, and in the early days of valve manufacture the special pumps used for exhausting the air from the bulbs were not as efficient as those used to-day. Furthermore, modern valves are mostly covered inside the bulb with a silvery substance known as "gettering," which is the residue left over from an electro-chemical process which removes the last vestige of air remaining after the bulbs come from the exhausting pumps. By the way, this silvering is a necessary evil, and does not serve the purpose of hiding the "works" from inquisitive eyes as some people think. Well, as I was saying, in the early days of wireless the pumps were not so efficient and valves imperfectly exhausted were termed "soft," and in use often a blue glow could be seen around the cathodes. Some of you may remember the old Dutch bright-emitter which very noticeably "blue-glowed" and made such good detectors, and which led to the almost standard practice of keeping any blue-glowing valve for the detector stage. Nowadays, such a valve is rare indeed, which is a very good thing, for its use in a modern circuit with modern components will only give rise to distortion and poor results generally. You might try such a valve in the detector socket, but I am afraid you will find it falls very far behind the special detector valves now available, especially as a "blue-glowing" valve generally works best with an unusually low H.T. voltage, some of the Dutch valves I referred to giving the best results with about 25 to 30 volts on the plate.

## Gift Tokens

**I** SEE that a novel scheme has been launched by an association of booksellers to make easy the way of present-donors who are uncertain of the recipient's wants. A token of any value can be purchased and given as a present, this being taken to any book-shop, and a volume or volumes of appropriate value chosen. It ensures that the person who receives the gift obtains exactly what he wants, and the giver is relieved of a lot of responsibility. Could not some such scheme be evolved in the radio trade? How convenient for a rich uncle, when his nephew's birthday comes along, to give him a token for, say, ten pounds, and how great for the radio-minded nephew to be able to rush off and buy the parts for the very latest PRACTICAL WIRELESS set! At Christmas, too, it would be a boon, for, to anyone keen on wireless, a radio token would completely fill the bill as an ideal gift, for what radio man could enter a radio shop with a token to the value of ten shillings without being able to find something he had been wanting for a long time?

(Continued on page 742.)

## HOME CHARGING



Why not charge your accumulators in your own kitchen? Simply connect one side of the Heyberd Battery Charger to the Mains—the other to your accumulator. You will save money, time and trouble this way. And... your L.T. Batteries will last much longer.

Model A.O.2. Charging 2, 4 or 6 volts at 4 amp. ... 35/-  
Model A.O.3. Charging 2, 6 or 12 volts at 1 amp. ... 42/6

Both models incorporate Heyberd Transformer and Westinghouse Rectifier. Complete in neat steel case—no external resistances required.

**HEYBERD**  
MONARCH OF THE MAINS.



**Post Coupon**

for Heyberd handbook on Mains Working

I enclose 3d. stamps for New Handbook of Mains Equipment. Packed with Technical Tips, Service Hints and diagrams

Mr. \_\_\_\_\_  
Address \_\_\_\_\_ P.R.A.

**F.C. HEYBERD & Co.,**

10 FINSBURY STREET, LONDON, E.C.2  
One minute from Moorgate Stn

## Engineers' Guide

CONTAINING the WIDEST CHOICE OF ENGINEERING COURSES in the WORLD Study at home with the T.I.G.B. for a well-paid post. Become an A.M.I.C.E., A.M.I.Mech.E., A.M.I.E.E., etc. Training until Successful is Guaranteed for the one fee. WRITE NOW for Free Guide, stating branch, post or qualification that interests you to

THE TECHNOLOGICAL INSTITUTE OF GREAT BRITAIN, 252, Temple Bar House, London, E.C.4

(Founded 1917. 18,000 successes.)



**To Success**

## Radio Ramblings

(Continued from page 741.)

### Testing with 'Phones and Battery

WHEN testing parts by the 'phone and battery method, it is as well to insert a resistance of about 10,000 to 30,000 ohms in series with one test lead, when making contacts with circuits carrying really high voltages, both to protect the 'phones and your ears. This method of testing is crude, perhaps, but it has the advantage of being always ready to hand and calls for no expensive instruments. It gives a certain indication when a fault is present in a component, but it gives no indication of the degree of the fault. The testing of fixed condensers that are suspected of having broken-down always presents difficulties to the beginner, as a click will almost always be heard when first touching the two terminals of such components. If the circuit is broken, and again touched, the click should be very much diminished or else not be heard at all if the fixed condenser is in good order, as by this time the condenser has become charged to the potential of the battery being used in the test. If the condenser has broken down it will not hold this charge, and the current will drain away, allowing a click to be heard every time the 'phones are connected across the terminals. Sometimes, a suspected primary of an L.F. transformer will give a loud click, even though it is broken down at some point. This is because a fixed condenser of small value is sometimes incorporated inside the case across the primary windings, but only if a click is heard when breaking circuit is the transformer in good order. That is, when the test leads are removed from the primary terminals, a click almost as loud as that in the beginning, when first connected, should be heard. Coils can be tested in the same manner, but if the coil has been wound with wire of fairly high resistance, the clicks will not be very loud, but to hear a click at all is almost all that matters. After a little practice, the state of a H.T. battery can be estimated by the volume of the click, when 'phones are connected across, but to prevent too great a drain being taken from the battery, it is as well to insert the resistance in series as mentioned above to keep the sound within the capacity of your ear-drums.

### Wireless Precautions for the Festive Season

BY the time you are reading this, your minds will be full of the good things that are associated with festivities and the New Year. It is the season of parties, and wireless will play a large part in making the festivities go well. Numerous tricks and dodges can be played with the amplifying section of your wireless set, and by obtaining a microphone and connecting it in your pick-up circuit, a new avenue of amusement is opened. The numbers of stunts you can arrange are endless, and it forms no part of my duty to enumerate them to you. You will have read of many of them elsewhere, and still more will you discover by your own ingenuity. I feel, however, I should like to say a few words on behalf of your wireless set, as there is a danger that with the very high spirits that usually prevail at most parties, it may possibly be subjected to rather rougher handling than is usual. Try and see that the set is not used in a way which makes it necessary for everybody

to handle the dials. This may sound a wet-blanket attitude, but it is a fact that much harm can be done to your tuning-condensers, if wrenched or forced by revellers not used to working them. If possible, keep your set in another room, away from the main body of guests, and instal a loud-speaker on a long lead in the room where dancing or games are being arranged. In this way, the danger of the set being knocked down, or in any other way coming to an untimely end, is obviated. If you use a battery set, do make sure that your H.T. is up to the big drain shortly to be taken from it, and the same also applies to the accumulators. See to these at least a week before, because the radio dealers may be closed when it eventually runs out and there is sure to be a rush on the charging stations during the holidays. In the same way, if you have been promising yourself a new valve or two for some time, buy it now, because you will need every ounce of volume your set is capable of if dancing to the wireless or gramophone is anticipated. It is surprising what a large volume of sound is needed for dancing, and it is hardly fair to yourself or your set to give your guests a weak, distorted output, due either to poor batteries or worn-out valves. Finally, take care that no likely sources of danger to your visitors are carelessly left open. Keep all trailing leads away from places where people are likely to trip over them, this particularly applying to "live" leads carrying mains current, and do not put loud-speakers, valves, or components where harm is likely to befall them. When carrying out stunts with the set, or manipulating the switches, take care that at no time a pentode-output receiver is allowed to function without a loud-speaker being connected to the appropriate terminals. I have told you before of the dangers of voltage rise with these valves, when on open circuit. Well, I hope you have the very best programmes it is possible for you to have, and that your sets will excel themselves, and also that the New Year will be one of more prosperity and happiness in wireless, and even excel the one now terminating.

### Many Uses of the Photo-electric Cell

STILL further uses are being made of the ubiquitous selenium cell, sometimes termed (in error) a photo-electric cell, and more popularly "invisible ray." You may have read about a well-known hotel or roadside hostelry which is floodlit every time the headlights of an approaching car shone on a carefully placed selenium cell arrangement, and now the presence of smoke passing through a ray of light can be made to give the alarm in the case of fire. Garage doors can be opened and shut, burglar alarms can be set into motion, and articles in course of production can be counted by means of this modern wonder, but don't lose sight of the use for which it was primarily intended—that of television.

### Long Pick-up Leads

I WAS talking a week or so ago of the use of output transformers when using a loud-speaker at some distance from the set. Now a correspondent inquires about long pick-up leads, and it struck me that there must be cases where these are inevitable. For instance, if the owner of a quite elaborate and costly cabinet gramophone invests in a wireless set, it might be quite inconvenient for him to move his set to the gramophone or vice versa when he wants to hear some records via the speaker. We are



always cautioned against long grid wiring, and the addition of the capacity due to several feet of pick-up wiring cannot be anything but detrimental to results generally. In this case it is possible to obtain from most transformer makers a suitable transformer to fit to your pick-up which will allow of a gramophone operating an amplifier at any distance from the pick-up. As there is perforce a very limited demand for transformers of this kind, I do not believe they are generally advertised, but they can be had if you approach transformer makers; the only details necessary are those concerning the make of your pick-up, as the resistances of these vary considerably.

**About Grid-Leaks**

DO you remember the days when we invariably used a variable grid-leak in our sets? The principle was sound in theory, but mechanically more was lost than gained by their use—I say mechanically because it was the problem of the design of such a leak that proved insurmountable, considering the limitations regarding cost and space. At the same time, it is realised that a mean value of grid-leak is not always best, and sometimes a satisfactory compromise is often difficult to achieve. In these cases it is best to place your grid-leak in a place where it can be easily reached, or at least to keep it free from overhead wiring as much as possible, so that leaks of different value can be slipped in without the need for wrecking the set. While leaks of 5 megohms are best for long-distance work, the best quality is obtained from the local station with leaks of quite low value, and it pays to experiment in this direction, the above remarks only applying where leaky grid detection is used.

**Using 'Phones for Long-distance Work**

MOST of us nowadays tune in on the loud-speaker as a matter of course, but for really long-distance work, especially on the very short waves, headphones cannot be beaten when knife-edge tuning is employed. Moreover, when two or more tuning controls are used, the circuits can be kept in resonance much more easily if the soft sibilant hissing noise indicating this state of affairs can be easily heard without the distraction of outside noises. The snag comes when a station suddenly comes through with a strength sufficient to shatter your eardrums, and it is not pleasant nor desirable that you should allow your ears to suffer this discomfort. When listening with headphones I often insert a spaghetti resistance in series, which makes listening comfortable, and which at the same time removes much of the fearful clatter with which the ether is full nowadays. A megohm is the maximum value that should be used.

**New Year Greetings**

I SHOULD like to add my voice in wishing you all a VERY HAPPY NEW YEAR, and hope that you will have your fair share of enjoyment and interest from the pursuit of your hobby of wireless—one of the finest hobbies it is possible to have. At the end of each year we look back over the events that have occurred, and I for one always wonder what will have happened by the end of the new one.

**A Year of Progress**

WHAT do you consider to be the most outstanding development during 1932? There has been nothing that can be called revolutionary as regards wireless, but it cannot be disputed that steady pro-

gress has been made in many directions. Cabinets have assumed a slightly more modern note, and the popularity of the arrangement whereby the set and the speaker are housed under one roof, as it were, has been noteworthy. Ganging has once more come to the fore—and I say once more because some years ago it had a minor vogue, which quickly petered out, due to the excessive "trimming" required at both ends of the scale—and the screened-grid valve and the pentode have dug themselves in until they have become standard. None of these things may be termed peculiar to 1932, however, although we might consider metallized valves and the variable- $\mu$ 's to be newcomers of distinction. Television has not progressed as much as we might have expected, and I am afraid we will not see the 1933 Boat Race and Derby—a dream that seems to have peculiarly captured the imagination of the more rabid radio-seeing enthusiasts. The Empire broadcasts have given a fillip to the ultra-short waves, and I make bold to say that I expect still further developments to take place as regards the work on the very high frequencies. Anyway, I am going to give you my views as to the two most important happenings of 1932, as judged from the standpoint of the serious amateur who requires the very best from his radio. They are, firstly, the advent and extreme popularity of the cheap permanent magnet moving coil and, lastly, but not "leastly," the introduction and firm establishment of PRACTICAL WIRELESS. If it were not for modesty, I should say the last was the most important; but perhaps I should leave that to you.

**Test Match Broadcasts**

IF you habitually listen on the ultra-short waves in the early hours of the morning you will be interested to learn that every Test Match of the present series will be broadcast by Amalgamated Wireless (Australasia), Ltd., from their station, VK3ME on a wavelength of 31.55 metres. Descriptions of the play will be sent out at intervals from 3 a.m. to 8 a.m. G.M.T., and, if you have time on your hands at these early hours, why not tune in?



# STOP BUYING DRY BATTERIES

HERE'S A CHEAPER WAY TO GET BETTER H.T. ONCE AND FOR ALL

Free Booklet Tells You All About the

## STANDARD

Leclanché Self-Charging PERMANENT H.T. BATTERY

Thirty per cent. reduction. And we sell direct to give personal advice and attention. The STANDARD battery recharges itself when the set is shut down, and so gives ample level current, month after month, year after year. Dead silent background. Brings in difficult stations at their best. These advantages are enjoyed by thousands PERMANENTLY, because the eventual replacement is merely a matter of changing cartridges at a few pence each. Send for the free book NOW.

Popular Type Battery for Ordinary Sets

Any voltage, Any capacity, Model H5, No. 3 size, 12,500 milliamp capacity, 126 volts, 84 cells. Price, complete 5/- Down without trays, Tray containers extra if required. 37/8

Other capacities 2,000 to 25,000 milliamps  
STANDARD BATTERY CO., Dept. N.W.  
184-188, Shaftesbury Avenue, London, W.C.2

Famous Maker's Offer! £5 Radio-Gram CABINET for 65/- SEVEN DAYS' FREE TRIAL (OR 10/- MONTHLY)  
Polished Oak and Piano built! The acoustic Tone brings a fine thrill. Makers to Radio-Press B.B.C., 3,000 clientele.  
Other Models 35/- to £15. Photographs and List FREE.  
PICKETTS Piano-Tone Cabinets. (P.B.) Albion Rd., Bexleyheath

The SLEKTUN "SCOUT S.G.3." Simpler than ever to build  
FREE Blueprint and Illustrated Construction Guide combined. Very practical instructions for building this great set—the complete kit of which costs only 84/-. Write for a Free copy of the New Blueprint Guide, sending 3d. in stamps for postage.  
Slektun Products Ltd., 21, Douglas St. Westminster, S.W.1

LOUD SPEAKERS REPAIRED. 4/- (Blue Spot a Speciality, 5/-)  
Transformers 4/-, all repairs magnetised free. Eliminator Repairs quoted for. 24 Hours Service. Discount for Trade. Clerkenwell 9069.  
E. C. MASON, 44, EAST ROAD, LONDON, N.1.

LOUD SPEAKER REPAIRS  
Any make Unit, Transformers, etc., from 3/-; Blue Spots, 5/-; Moving Coils, Eliminators, etc., from 5/-. Repairs guaranteed laboratory tested and returned C.O.D. post. Special trade terms or by contract.  
WEEDON POWER LINK RADIO CO., 185, Earlham Grove, London, E.7. (Phone: Maryland 4344).



## COMMENTS ON COMPONENTS

### IGRANIC PICK-UP

THE Pick-up manufactured by the Igranic Company, and illustrated below, is a very efficient instrument of rather original design. The entire apparatus is finished in brown, with the base and pick-up head moulded in bakelite. The base is of square shape and so provides a very solid fixing point for the arm, thus reducing the risk of vibration chatter due to an insecure support. The arm is held in a gimbal fitting; a counter-balance weight at the rear of the tone-arm completely avoids pressure wear on the record; and these features, combined with an almost frictionless swivel action on the support, will enable the records to be used practically indefinitely with very little trace of record wear. The magnet system is made up from cobalt steel and the needle holder is rubber damped, with the armature arranged so that the frequency response is practically uniform when used with modern records. The pick-up may be rotated for easy needle changing. The price of the complete Pick-up with Tone Arm is 35s., and the pick-up only may be had for 20s.



The Igranovox pick-up, showing the solid foot and gimbal mounting.

### PREH VARIABLE POTENTIOMETERS

SAMPLES of the two types of potentiometer now manufactured in this country by the Preh Manufacturing Co., Ltd., have been sent to us for review, and these are extremely neat and small. One variety bears the name "Multiohm" and the other the "Multiohm-Luxus," the latter being of the friction disc type, whilst the former is of the slider type. The rating of each model is 2 watts, and both types are wire wound, and made in values from 2,000 to 25,000 ohms. The winding is protected by a metal case, and the value of the component is boldly marked on this casing so that the actual resistance is at all times observable. Too many components of this class have the value printed in some out-of-the-way position in microscopic figures. The workmanship of these resistances is quite good, and the action is very smooth. On test the values were found to be reasonably accurate, both values being slightly above the actual rating. The error, however, was under 10 per cent. The current rating was extremely conservative, and the full 2 watts could be dissipated with only the slightest rise in temperature. At 3s. for the ordinary model, and 5s. for the *de-luxe* model, these are components which can thoroughly be recommended.

### NEW G.E.C. D.C. MAINS SET

THE "Gala" is a 3-valve "All-In" D.C. table model, of the H.F., detector and pentode type, incorporating the standard G.E.C. features adopted this season, i.e., moving coil loud-speaker, single knob tuning and a heterodyne filter. These are in addition to the automatic station index—which permits tuning in directly to stations by name on a full vision horizontal scale. This is the neatest and simplest arrangement of its kind. The set has a wave-length range covering 200-550 metres on the medium band, and 900-2,000 metres on the long band, and is suitable for use on mains of from 200 to 260 volts, the terminal board being arranged for three tappings, viz., 200-220, 220-240, and 240-260. The instrument incorporates two tuned circuits with a single H.F. valve feeding a screen-grid detector. The aerial is loosely

coupled to the first circuit, and transformer coupling is adopted in the anode of the H.F. valve. The screen-grid detector is resistance-capacity transformer coupled to the pentode output valve, which feeds the moving coil speaker. This speaker is similar to that incorporated in the "Nomad" receiver, previously referred to. Its field winding is run in series with the heaters of the valves, and the reproduction is a marked improvement over existing D.C. sets.

Adequate power is available. Except in areas remote from high power transmitters, it will be found advisable to adopt a reasonably short aerial for the best compromise between sensitivity and selectivity, while for the reception of high-power local stations a small internal aerial which has been incorporated will in most cases be found sufficient. The set has three controls. On the left hand is the volume control and "on-off" switch; in the centre the tuning control, and on the right hand is the wave change switch which simultaneously operates the automatic station index. Two sockets are provided at the back of the neatly-finished walnut cabinet for the connection of a gramophone pick-up. The valves employed in this set are of the Osram indirectly-heated type, with 16-volt heaters. The consumption of the set is approximately 65 watts at 200 volts, increasing to 75 watts at 260 volts, and the undistorted output is of the order of 1-1½ watts A.C., according to the voltage of the supply.

### BULGIN WALL JACKS

WHY not a loud-speaker in every room? Occasions continually arise when it would be pleasant and convenient to have radio in a bedroom, nursery

or kitchen. A system of wall jacks is easily fitted, and such an arrangement will please every member of the household. But isn't it an expensive matter? you ask. Not at all. Wire is cheap enough, and the Bulgin Midget Wall Jacks cost but 1s. 6d. each. They are arranged for series or parallel wiring, and are finished in walnut or mahogany bakelite. The plugs also cost 1s. 6d. each, one only of these being required for each loud-speaker.

### NUGANG CONDENSER

THE condenser illustrated is one of the Nugang series, manufactured by Jackson Bros., and is a very soundly constructed component. This is of the fully screened type, having, in addition to the clipped on, separate small metal screens which may be clipped on to the plates separating each section of the condenser, and thereby completely screening each section when the cover is on. Each section is provided with a separate trimmer, having a large star-wheel adjustment. Soldering tags are fitted on each side so that connection may be taken from the stators to the coils on one side and to the valve on the other. This greatly simplifies the layout and enables the length of leads to be reduced to a minimum. The end plates of each rotor are split and the sections are accurately matched to within ¼ mmf. plus ½%. The entire assembly is very robust and will be found fully up to the standard of Jackson pro-

# What we Found..

ducts. The condenser is available in 2, 3 or 4 gang types, with a capacity of .0005 mfd., and the price is 10s., 23s. 6d. and 31s., respectively.

### CLIX CHASSIS MOUNTING VALVE-HOLDERS

THE capable home constructor of to-day is following closely on the heels of the set manufacturer, and is generally using the "chassis" method of construction. This permits a clean lay-out, with most of the wiring "below deck." The newest "Clix" valve-holder, here shown, is an ideal component for

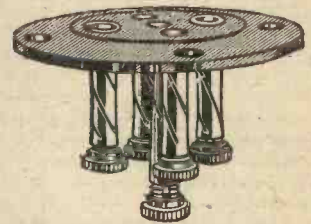

The Clix chassis mounting valve-holder.

this method, whether used on raised wooden base or metal chassis. In appearance a "skeleton," it is yet exceedingly strong and thoroughly sound mechanically. Who has not experienced the holder into which the valve has to be forced, or, on the other hand, the feeling that some of the pins are not contacting, because the valve seems to "fall in." The Clix sockets are able to move laterally, and so align themselves to the pins, while their spiral form gives resilience and ensures maximum surface contact without fear of collapse. The valve is inserted with perfect ease, and comforting assurance. The cost is only 8d. each for the four-pin, and 9d. for the five pin models. They are, of course, sold at most radio dealers.

### SCREENED STANDARD H.F. CHOKE

FOR all ordinary sets this choke is ideal. Built on the same lines as the super-hot model, it is slightly smaller, with an inductance value of 250,000 microhenries. It covers a wave-band of from 100 to 1,800 metres without resonant points or blind spots, and has an approximate self capacity of 2.5 mmf. Screened, as is very necessary in modern sets, its cost is 3s. 6d. The makers are A. F. Bulgin and Co., Ltd., Abbey Road, Barking.

### HEYBERD TRICKLE CHARGER

IN our issue dated December 24th, page 706, we illustrated the Heyberd Trickle Charger. Through a mistake in the information supplied this is shown as their model A.02. but should read A.03.

Have you Reserved YOUR Self-Binder for our Free Data Sheets?  
(See page 727)

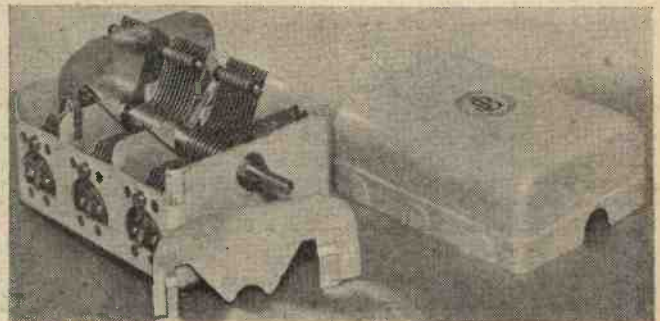

The "Nugang" fully-screened variable condenser, with one of the detachable screens removed to show the method of fixing.



# Practical Letters

from

## Readers.

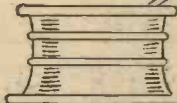

The Editor does not necessarily agree with opinions expressed by his correspondents

### Det. 2 L.F. Set with Bandpass Tuning

#### Wanted

SIR,—Lest the Technical Department should run dry of material for those most practical articles which have made your publication what it is—the most practical wireless weekly—I suggest that they should come out with a really up-to-date Det. 2 L.F. set with bandpass tuning. I know I risk being laughed at for my old-fashioned idea by the high lights of the art, who say a set without a S.G. stage cannot be up to date. The 3 and 4-valvers so far published by you undoubtedly take front rank in their line, but I for one have no use for any new set to run after the foreigners with until I get a guarantee against fading, and when you choose to come out with a really hot circuit with a number of variable-mu valves and automatic volume control, I will build it for long distance work, and still keep a Det. 2 L.F. set for household use. There must be tens of thousands of old hands like myself sticking to their first love. I have built and rebuilt my sets time after time when new (or hashed-up old) circuits, coils and tuners came out, and sometimes got a little more selectivity and a little quality, or *vice-versa*. No doubt Mr. A. J. Wood's loose-coupling idea on page 343 of November 5th issue, and Mr. Preston's Bandpass Adaptor on page 537 in December 3rd issue, would go a long way towards solving the selectivity trouble with old sets, but most old hands would sooner work on a complete circuit than on an additional box of tricks. By Det. 2 L.F. bandpass tuning, I do not mean expensive and bulky gangs of condensers with matched and screened coils, but a circuit with 2 separate variables, and everything else adjustable on the panel. No variable condensers to get at, or not inside the set, please. Most components for such a circuit would be found in our old sets or the wireless treasure box, apart from perhaps two new coils. I hope you can see eye to eye with me, and that you will publish a set incorporating these features in the near future.

Wishing PRACTICAL WIRELESS the continued success it deserves.—F. M. B. (London, W.C.).

### A Plea for Plug-In Coils

SIR,—The letter of A. Bedding (Clapham) in issue No. 12 has voiced my wishes regarding a good selective circuit for plug-in coils, and I am pleased to read that you have something on these lines for us in the near future. May I make a suggestion, which would remove that bugbear of

plug-in coils, viz., coil changing? Can you give us a circuit in which high and medium waveband coils are on the same base board and some simple switch device to cut out the waveband not required? I much prefer plug-in coils, but I have a dual wave coil in my set in deference to the female side of family, to whom coil changing is anathema. I hope, if this is a feasible proposition, to see it in your columns in the near future.—W. OSBORN (Chatham).

### Topping Accumulators

SIR,—Referring to the method of topping up accumulators, suggested by a correspondent in your issue for December 3rd, I should like to draw attention to the fact, well known to most persons habitually handling sulphuric acid, that water should *never* be added to the acid, the contrary obtains, the acid should be added to the water. If water be added to acid, great heat is generated, which undoubtedly will shorten the life of the accumulator, and if the container be of glass, the heat may cause it to crack, with danger to the user by acid burns. I know that the method suggested is adopted by some careless operators at charging stations (so called) with a beautiful disregard of their customers' property. May I be allowed to offer my method, which is safe, and involves little expense or trouble. Have handy a small spouted milk jug, put in sufficient distilled water for topping up, that is, to cover the plates well (easily estimated), then by means of a glass syringe (rubber bulb on a glass tube), an arrangement similar to that used on hydrometers for testing the s.g. of acid, withdraw a fair quantity of acid from the accumulator, release into the water in the jug, and pour back into

the accumulator. Scarcely any heat will be developed, and a rinse in water renders the apparatus used harmless. Anyone who handles acid should have handy a bottle containing a strong soda solution, some of which should be applied to anything brought into contact with the acid, which is then quickly neutralized, and thus prevents injury.—W. BURCHELL (Westcliff).

### Constructional Article on Dual Range Tuner

#### Wanted

SIR,—Being a regular reader of PRACTICAL WIRELESS, I wish to ask a favour of your technical staff. Will they give in an early issue the constructional details for a good tuner for medium and long wavebands. I may say that ever since your paper came out I have watched eagerly for such an article, but have not seen one. I take a great interest in building up sets and I find that dual-range coils at 17s. are too much for we poorer radio fans, and from my past experience I know what a saving it is to construct coils, etc., for oneself. I may say that up to now I have found PRACTICAL WIRELESS the best threepennyworth we have had for a good many years. Before I close I want to ask you just one thing more, and that is—please cater a little more for those who cannot afford expensive components.—R. TOASE (Darlington).

### Five-Valve Portable Wanted

SIR,—I thought it would be of interest to the technical staff of PRACTICAL WIRELESS to know the demand there is among the home constructors for diagrams and all necessary information with regard to the components and their values for the construction of a five-valve portable set. I am in a position to know what is required as I am secretary of a wireless circle which has a membership of over one hundred. I have been a wireless amateur for a good many years and I think your journal is the best yet. Hoping you can publish the required information in the near future.—W. T. GOODISON (Westerham).

### Congratulations—Still They Come

SIR,—Allow me to congratulate you on your most interesting journal, PRACTICAL WIRELESS. It is by far the most interesting periodical of its kind I have seen. It puts everything in such a clear and straightforward way for those who, I think, should be studied a little more than they have been in the past, viz., the amateur constructors. At the same time your paper is quite as interesting for the more advanced amateurs. The circuits described are suitable for everyone. Altogether, I consider it a splendid paper and wish it every success.—S. BURNARD (Boscastle.)

CUT THIS OUT EACH WEEK

## DO YOU KNOW?

- THAT the automatic bias circuit of an output valve should always be decoupled.
- THAT selenium, the well-known light sensitive substance, is insoluble.
- THAT sal ammoniac is one of the best substances to use for tinning a soldering iron.
- THAT all switches which carry a fairly large current should be of the quick make-and-break type to avoid arcing.
- THAT an electro-magnet may be roughly improvised by winding a quantity of wire round an ordinary nail.
- THAT television images are broadcast with a frequency of 12½ pictures per second, each divided into 30 strips.
- THAT a loud-speaker horn to reproduce faithfully a note of 64 cycles would have to be over 6ft. long.
- THAT only one P.O. licence is necessary for a home receiver and a portable.

## The Autokoil Pentode Two

(Continued from page 729.)

turn this knob until the reaction stops. Now upon adjusting the variable condenser the nearest B.B.C. station should soon be picked up and the left and right-hand controls may then be employed to ascertain the optimum positions. With this ingenious unit it will be found very simple to obtain any degree of selectivity or signal strength, and this will be found most valuable when it is desired to listen to a station which is situated some distance away and is working on a wavelength close to a near-by station. By suitably adjusting the three knobs it will be found possible to obtain quite a good programme which would otherwise be impossible without much more elaborate apparatus. The tone from this receiver is very good indeed, owing to the choice of the constants

of the tone compensating circuit in the anode lead of the pentode valve, and providing these are not altered, and the valve

## NEXT WEEK'S FREE GIFT DATA SHEET is entitled "MAINS TRANSFORMERS"

which is specified is used, the response will be found extremely good.

No list of stations which can be received has been given, as conditions will vary with individual listeners. For instance, a listener living at Barnet, which is on top of the Brookmans transmitters, will have to employ a much higher degree of selectivity to enable him to hear the Midland Regional, for instance, and consequently there will be a slight loss of signal strength on that station. A listener, on the other hand, who is situated at Margate would not require the same degree of selectivity and would therefore be able, no doubt, to bring in the Midland at greater strength. However, that is a point which depends upon local conditions. For those who require it, a full-size blue-print is obtainable for 1s., and a complete set of parts for the receiver is obtainable from Messrs. A. W. Hambling, Ltd.

## Thinking in Terms of Frequency

(Continued from page 724.)

notice. If two violin strings which are slightly out of tune with each other (that is, they vibrate at slightly different frequencies) are sounded together, the volume of sound will wax and wane rhythmically, the frequency of the "beat" depending upon the extent to which the strings are out of tune. This effect, of course, is due to the fact that, the sound waves being of slightly different frequencies, they will, at a given moment, be "in step," when their energies will be added together; and a little while after they will be exactly opposite in phase, so that they will almost cancel each other out.

A similar effect can be obtained with radio waves. Two signals of almost identical frequency will combine to produce

a beat frequency which may be of audio frequency, in which case it will be heard in the speaker as a high-pitched whistle, commonly known as a "heterodyne" whistle. In the present congested state of the ether it is impossible to provide any real remedy for heterodyne whistle. However, an effective method of cutting it out, with some sacrifice of quality, is by including in the audio-frequency portion of the receiver circuit a filter which cuts off all musical frequencies above, say, 8,000 cycles, including, of course, the heterodyne whistle. A certain lack of brilliance in tone results, but this can be compensated for in some degree by the use of a pentode output valve, which has a particularly good high note response.

Although heterodynes are a great nuisance when due to outside causes, the

principle is usefully employed in the "super-heterodyne" receiver. In this type of set the incoming radio-frequency signal is "mixed" with another radio frequency differing slightly from it and produced by a local valve oscillator. The frequency of the impressed local oscillation is so adjusted that the best frequency is above audio frequency but below normal radio frequency. This "supersonic" or "above-sound-frequency" wave or current carries, of course, the same modulation as the original signal, and is further amplified before detection. The advantage of this system is that supersonic frequencies can be amplified much more efficiently than radio frequencies, because smaller circuit losses are incurred. A reasonably high degree of selectivity, combined with great sensitivity, is thus secured.

## What is Television?

(Continued from page 731.)

reason as we ruled out selenium at the transmitting end. If you think for a moment you will realize that there are several thousands of minute light variations at the transmitting end during the course of a complete exploration carried out by the scanning spot. Our light source at the receiving end has to respond just as rapidly and faithfully, glowing darkly or brightly with intermediate shades as necessary.

There is more than one way of carrying this effect into practice. For example, a beam of light from a projection lamp can be modulated by what is known as a "light valve," but the simplest method for using in conjunction with our perforated scanning

disc is to employ a neon lamp. A few forms of this lamp are shown in the accompanying illustration, but in the most elementary of sets it is possible to use the beehive or spiral pattern neon lamp so useful for domestic purposes, especially as night lights. Or again, the shaped letter pattern normally employed for advertisement signs can be pressed into service. In the centre of the lamp group will be noticed what are termed flat plate neons. These are the best (and of course the most expensive) for television reception, as the metal plate glows uniformly over the whole flat surface, and this in turn is scanned by the perforated disc. Each of the lamps mentioned is filled with a gas called neon at a very low pressure, and the characteristic reddish orange glow is brought about by the neon atoms becoming heated through atomic

bombardment. Unfortunately, the intensity of this form of illumination is fairly low, but in a well-built piece of vision apparatus having the neon lamp properly modulated by the incoming signal, the images are bright enough to be watched in comfort in a dimly lit room. The family group shown looking in at a "Televisor" in the illustration will indicate what I mean in this connection.

Since the image built up from the spiral of holes round the edge of, say, a 20in. disc, seldom exceeds lin. in width, it is necessary to place a lens or combination of lenses in front of the rotating disc and light source in order to enlarge the image. This, of course, is quite a simple matter and a single convex lens, together with a double convex lens, gives a magnification quite sufficient for ordinary purposes.

## CLUBS and SOCIETIES

We shall be pleased to publish brief Club reports. Such should not exceed 150 words in length, and should reach us by Friday of each week.

### VISIT TO A BIRMINGHAM BROADCASTING STUDIO

The Smethwick Wireless Society paid an interesting visit to the studio of Messrs. Wm. Bayliss, Ltd., Sheepcote Street, Birmingham, on the evening of Friday, November 25th. The large number of members and friends who took this opportunity of seeing an actual broadcasting studio were cordially welcomed by Mr. Gould, who proceeded to demonstrate the reproduction of gramophone records by means of an experimental split-frequency amplifier. By means of channel balancing a perfect reproduction was obtained in which all frequencies were adequately represented.

Particulars of membership of this Society can be

obtained from the Hon. Sec., Mr. E. Fisher, M.A., 33, Freeth Street, Oldbury, nr. Birmingham.

### A RADIO LEAGUE OF NATIONS

The Anglo-American Radio and Television Society and the associated society, The International Radio Society, aim to promote goodwill and fellowship between nations. The societies have members in thirty-five dominions, territories, and foreign countries, and members of the society may communicate with fellow members in any part of the world. No charge for membership to the society is made and for this reason a stamped addressed envelope should be enclosed with all communications. Anyone desiring may join. All they have to do is to send their name and address to the Headquarters, 11, Hawthorn Drive, Willowbank, Uxbridge, England. No charge is made and members are under no obligation to the societies.

The societies aim to aid radio and television enthusiasts by supplying them with radio data, etc. The societies have also organised branches throughout the world. The most advanced is at Huddersfield, Yorkshire. This branch has its own club room, S.W. receiver, orchestra, dramatic society, and Morse classes. Joining a branch (2s. 6d. per annum) is

optional; membership of society is free. The President is Leslie W. Orton.

A bulletin called *Radio* is presented free to members.

### LOUD-SPEAKER TEST

The members of the Bradford Radio Society spent a very interesting time at a recent meeting when a loud-speaker demonstration was staged. A 12-watt amplifier was used for record reproduction, and a number of loud-speakers were placed on the platform behind a screen. The same record and the same portion was used for each test, a particularly good one having plenty of both top and bottom. The speakers were taken in heats of three, the winners of the heats taking part in the eliminating round to find out which speaker, by popular vote, was the best.

Not a single member in the audience knew which speaker was actually being used at the different stages, and it was not until the conclusion that the audience was enlightened as to the makes and names of the speakers, which ranged from models at just over £1 to others costing £8. It is distinctly gratifying to local industry to find that it was local product which secured both first and second places.

LET OUR TECHNICAL STAFF SOLVE  
YOUR PROBLEMS

REPLIES TO



If a postal reply is desired, a stamped addressed envelope must be enclosed. Every query and drawing which is sent must bear the name and address of the sender. Please your queries to The Editor, PRACTICAL WIRELESS, Geo. Neumes, Ltd., 8-11, Southampton St., Strand, London, W.C.2.

QUERIES and ENQUIRIES  
by Our Technical Staff

The coupon on this page must be attached to every query.

SPECIAL NOTE.

We wish to draw the reader's attention to the fact that the Queries Service is intended only for the solution of problems or difficulties arising from the construction of receivers described in our pages, from articles appearing in our pages, or on general wireless matters. We regret that we cannot, for obvious reasons—

- (1) supply circuit diagrams of complete multi-valve receivers.
- (2) Suggest alterations or modifications of receivers described in our contemporaries.
- (3) Suggest alterations or modifications to commercial receivers.
- (4) Answer queries over the telephone.

Please note also, that all sketches and drawings which are sent to us, should bear the name and address of the sender.

BAND-PASS TROUBLE

"I have an All-Mains A.C. set, and it is of the band-pass tuning type. I cannot cut out Daventry National when I have Radio-Paris on, and yet I can get any other station as clear as I want it and no background. Can you please tell me how I can cut out this station when listening to Radio-Paris? The circuit is screen-grid, with a pentode output."—(A. S. T., Northampton.)

If the receiver employs commercially-made band-pass coils, the separation should be quite sufficient to enable you to hear Radio-Paris with no background from Daventry. As you cannot do this it would appear that you have not got the two circuits accurately matched, or have used the wrong value of coupling unit. If you are employing ganged condensers, you should pay attention to the trimming adjustment, and also make sure that you are using non-inductive coupling condensers or resistances, according to the requirements of the particular coils.

TESTING CONDENSERS

"I have some large fixed condensers in my set, and I wish to test them for leakage (if any), especially the two condensers in the R.C. transformer-coupled stages. I understand that any slight leakage in these condensers may result in bad distortion, through placing positive bias on the L.F. valves, thereby cancelling any negative bias from grid-bias battery, resulting in incorrect milliamper reading. Both Det. and L.F. stages are decoupled, also, I have a filter output, the choke being of first-class make, its specifications being D.C.C. resistance, 260 ohms, inductance, 14/28 henries."—(R. W. F. J., Northumberland.)

The simplest test is to connect the condenser across a fairly high value voltage supply, and leave it joined there for some time. Then disconnect it and avoid touching the terminals. At the end of an hour, short the terminals with a metal object, and if you can obtain a fairly good spark, the leakage from the condenser is negligible. The size of the spark will depend, of course, on the value of the condenser. In a dry atmosphere, the condenser will hold its charge for a longer period. To carry out a more efficient test, connect a high voltage, say, 200, to a voltmeter through a 25 megohm grid-leak, and note the reading, if any. Then connect the condenser to be tested in place of the leak. If the reading is less, then its resistance is proportionately more than the leak.

NOISES AND THE PORTABLE

"I have got a powerful portable five-valve receiver, but am troubled by terrible scratching and grating noises. I have read in your pages how to disconnect the aerial and earth to see if the noises are due to external influences, but with a portable I do not see how this can be done. Is it necessary to disconnect the end of the frame aerial? I might mention that the long-wave section of the aerial is wound with very thin wire, and I have heard that the acid fumes from the accumulator cause the wire to rot when it is thin-

and I am suspicious that this may be my trouble. Perhaps you can tell me how to find out without interfering too much with the set, in case I have to return it to the makers."—(P. M., Hounslow.)

The receiver, having its own aerial, must be tested in a different way. First of all, make quite certain that there is no variation in strength of the disturbances as the set is rotated through 360°. If, of course, there is the slightest falling off in strength of the noises in one position, it will tend to show that it is external interference. If, however, there is absolutely no alteration in strength, it points to the fact that it is the set which is at fault, and the following procedure will confirm this. Take the set into the bathroom (provided the bath is made of iron) and lower the set into the bath, or stand it on the bottom of the bath, although it will be better to hold the set in a mid-way position. If no noises are heard when the set is screened by the metal bath, then it is external influences which are the cause of your trouble. If, however, the noises can still be heard, it is obviously the set which is at fault. Of course, you will not be able to hear any stations when the set is so screened.

DATA SHEET No. 15

Cut this out each week and paste it in a notebook.

EUREKA RESISTANCE WIRE

S.W.G.	Resistance per yard	Yards per lb.	Current capacity
18	.37	48	3.5
20	.66	86	2.5
22	1.10	140	1.5
24	1.77	227	1.0
26	2.65	340	.5
28	3.91	502	.25
30	5.58	714	.2
32	7.35	943	.15
34	10.13	1,300	.1
36	14.84	1,905	.5

NOISY TRANSFORMER

"When I get near to my set I can hear music and speech coming from the transformer. Is this due to the action of the transformer, or is it some fault either in design or construction? If it is a fault, can I remedy it?"—(R. T., Blackpool.)

The noise is due to looseness, of either the laminations or the windings of your transformer. If the transformer is not enclosed in a case, you can press a finger on the ends of the laminations and see if this stops the sounds. If no amount of pressure will cure it, then it is the windings which are loose, and the result of the continued vibrations will be a breakdown. If only the core is loose, this may be tightened by adjusting the clamping nuts. If these are already tightened right up, pour some molten wax over the laminations and so keep them in position.

DOUBLE BAND-PASS

"I have been experimenting with band-pass circuits, and have found that it certainly does give a wonderful degree of selectivity. After making up a number of different coils and couplings, I have come to the conclusion that a number of such circuits incorporated in a multi-valve receiver, would surely give results as good as a super-het. Is it possible to use, say, two separate band-pass circuits—that is, four coils—in a S.G. detector and power circuit without any ill-effects. I should like your advice on this suggestion of mine."—(F. D. E., Maldenhead.)

The use of a number of band-pass circuits is, of course, well-known, and is employed in one very well-known eight-valve super-heterodyne. In a receiver of the type you mention, namely, S.G., Detector, and Power circuit, the use of a double band-pass arrangement will give a very high degree of selectivity, but in view of the matching difficulty, we would recommend you to use two sets of two-gang condensers, and not a four-gang arrangement. By employing this method you can use a complete band-pass circuit at each end of the panel, and wiring would be much simplified.

SCREEN-GRID VOLUME CONTROL

"I am building a S.G. receiver, and am rather at a loss to know which form of volume control to employ. As far as I can see, there are three methods in common use, the dimming of the filament, the adjustment of the S.G. potential, and the variable-mu valve. As I have not yet decided upon the H.F. stage, I should be glad to know the respective merits of these forms of control."—(O. J. K., Tring.)

The dimming of the filament is now rather out-of-date, although in some special circuits it is to be preferred. The control of the screening-grid potential is quite all right if carried out by a potentiometer adjustment, and not by a series resistance. The variable-mu is, of course, the latest development of the screen-grid valve, and has many advantages to recommend it. On the whole, as you are building an entirely new receiver, we should not hesitate to recommend that you employ this later type of valve, and you will find that it will be simpler to construct and will give you the best type of volume control.

TOPE CONTROL

"I have a rather antique four-valve set, employing two L.F. stages. The results are truly amazing, and I must say that although it employs a neutralized H.F. stage it gives me more stations than many of my friends' modern S.G. sets. The only point which I can criticize is the quality of the reproduction, and although I have tried modern L.F. transformers, I cannot always get the type of reproduction which I like. I want, therefore, to fit a tone adjuster of some kind, so that I can vary the reproduction of different instruments. Can I fit something to my present transformers instead of buying a new one, or do you not recommend this course?"—(A. W. M., Surbiton.)

You may vary the reproduction from your present transformer by connecting a tone-control circuit, but as the component is not an up-to-date one you may find that it will not be easy to decide upon the correct values. You may introduce troubles from various resonant points, etc., and we would therefore only advise you to buy a modern tone-control transformer. This can be substituted for your present component, and will enable you to carry out the adjustments which interest you without affecting the remainder of the circuit.

MAINS SET TROUBLES

"A few days ago I bought an A.C. two-valve set which is giving me a little trouble. The aerial stays are copper wire, which, I think, takes some of the power away from the aerial itself. Now for the main trouble: when tuning in to foreign stations the moment I touch the reaction I get a loud beat, then the station required comes in, and after that oscillation."—(E.2., Glasgow.)

We suggest that you effectively decouple your L.F. stage, using 25,000 ohms series resistance and 2 mfd. condenser. Also connect a .0002 fixed condenser from plate terminal of detector valve to earth. Provided aerial is well insulated at its free end, wire stays may be used.

FREE ADVICE BUREAU  
COUPON

This coupon is available until Jan. 7th, 1933, and must be attached to all letters containing queries.

PRACTICAL WIRELESS 31/12/32.

# CATALOGUES RECEIVED

To save readers trouble, we undertake to send on catalogues of any of our advertisers. Merely state, on a postcard, the names of the firms from whom you require catalogues, and address it to "Catalogue," PRACTICAL WIRELESS, Geo. Newnes, Ltd., 8/11, Southampton St., Strand, London, W.C.2. Where advertisers make a charge, or require postage, this should be enclosed.

### BULGIN KNOBS

SOME time ago we commented in our pages on the fact that the home constructor was often in a difficulty owing to the multifarious knobs which were fitted to components of different makes. This often leads to a very untidy-looking panel, and we suggested that perhaps manufacturers could standardise their controls. Messrs. Bulgin point out that this difficulty may be overcome, as they stock a very comprehensive range of control knobs, in either black or brown bakelite finish. These are illustrated on page 52 of the very complete catalogue which may be obtained by readers by sending 3d. in stamps to A. F. Bulgin and Co., Ltd., Abbey Road, Barking, Essex. In addition to these knobs, the whole range of Bulgin components is illustrated, and the catalogue is completed with a twenty-eight page manual which is packed with information which is of interest to every home constructor.

### FERRANTI POWER AMPLIFIERS

THE name of Ferranti is associated with high-quality receivers and amplifiers, and the home constructor will find the new pamphlet issued by this firm of great value. Seven amplifiers and receivers are described in this pamphlet, which gives the list of parts required; wiring diagram and layout; circuit diagram, and, what is most important of all, a response curve for each individual set. In the front of the pamphlet there are eight pages of notes on operation, and other relative notes. The sets dealt with are:

- (1) Three-stage amplifier for battery or eliminator operation.
- (2) S.G.4 Rand Pass Receiver for battery or eliminator operation.
- (3) D.C. Mains three-stage amplifier.
- (4) A.C. Mains two-stage amplifier.

(5) A.C. S.G.4 receiver.  
 (6) A.C. Mains two-stage amplifier.  
 (7) A.C. Mains S.G.4 receiver.  
 Each of these employs a push-pull output stage, and the undistorted output is given for each one. The pamphlet may be obtained by readers from Messrs. Ferranti, Ltd., Hollinwood, Lancs., on receipt of 6d. in stamps.

### BLUE SPOT LOUD-SPEAKERS

NO difficulty should be experienced in choosing a loud-speaker after reading through the lists issued by the Blue Spot Company. From the small loud-speaker unit selling at 15s. up to the complete cabinet Moving Coil at 87s. 6d., there is a most comprehensive range for selection. A Wave-trap at 10s. 6d.; Mains Disturbance Eliminator at 10s. 6d.; Pick-up at 63s., and Receivers up to 22 guineas show that this firm is now catering for every type of listener, and all readers who require information on these products should write to the company at Blue Spot House, 94-96, Rosoman Street, Rosebery Avenue, London, E.C.1.

### Broadcast Query Corner

UNDER the above title, with the assistance of a recognized authority on foreign broadcasting matters and a regular contributor to wireless publications both at home and abroad, we are inaugurating a special Identification Service, which should prove of great assistance to our readers. When tuning in well-known stations it happens frequently that listeners pick up wireless transmissions of which they fail to recognize the origin. It is to solve these little problems that the *Broadcast Query Service* has been organized.

In order that a careful search may be made it is essential that certain data should be supplied to the best of the inquirer's ability and knowledge. When sending such queries to the Editor the following rules should be followed:—

1. Write legibly, in ink. Give your full name and address.
2. State type of receiver used, and whether transmission was heard on headphones or on loud-speaker.
3. State approximate wavelength or frequency to which receiver was tuned, or, alternatively, state

between which two stations (of which you have the condenser readings) the transmission was picked up.

4. Give date and time when broadcast was heard. Do not forget to add whether a.m. or p.m.
5. Give details of programme received, and, if you can, some indication regarding the language, if heard.
6. State whether and what call was given and/or kind of interval signal (metronome, musical box, bells, etc.) between items.
7. To facilitate publication of replies, append a *non-de-plume* to your inquiry.

Although the service is mainly applicable to broadcasting stations, wherever possible replies will be given in regard to Morse transmitters (commercial stations, fog beacons, etc.) and short-wave broadcasts. For the identification, however, of stations operating on channels below 100 metres it will be evident to inquirers that a closer estimate of wavelength must be submitted than in the case of broadcasts on the medium or long waveband if successful identification is to be carried out.

All inquiries should be addressed to *The Editor, PRACTICAL WIRELESS, 8-11, Southampton Street, Strand, London, W.C.2.*, and the envelope marked *Broadcast Query Service*, in top left-hand corner. Stamped addressed envelope should not be enclosed, as replies cannot be sent by post, but will be published in due course in each issue of PRACTICAL WIRELESS.

### Replies to Broadcast Queries

FARCO (Reading): (1) With the exception of Berlin, Heilsberg, and Hamburg, all German stations on that night relayed dance music from London; the broadcast was also taken by Vienna; as you give no estimate of the wavelength we cannot say through which transmitter you heard it. (2) Radio Normandie, Fécamp. (3) Poste Parisien, Paris (France). BOTOLPH (Boston): (a) WKJ, Rocky Point, N.Y. (207 m.); (b) WAJ, Rocky Point, N.Y. (21.62 m.); (c) WKJ, Rocky Point, N.Y. (31.21 m.) and WEL and WEM, Rocky Point (33.52 m.). NIP (Romey): Grenoble PTT (France) on 571.2 m. CRESCENT (Kilbirnie): (1) Nurnberg relaying Munich; (2) Heterodyne; (3) Because, apparently, your set to receive Belfast was already on the point of oscillation. SURPRISED (Gloucester): New Leipzig high-power transmitter testing. D.X. FAX (Bedale): (1) WPG, Atlantic City (N.J.); (2) It is presumed that you do not mean metres but dial reading 33 degrees; Valencia (Spain) on 267.6 m.

## SELECTIVITY IS SIMPLE

WITH A **FORMO** BAND-PASS TUNING ASSEMBLY



**FORMO** Matched Coil and Condenser Assemblies solve the problem of making your set selective. You have a complete and accurate tuning unit giving the finest possible band-pass tuning. Perfectly matched coils and condensers give accurate selectivity and much finer quality.

A **FORMO** Matched Unit provides the home constructor with something new in performance and in straightforward set construction.

Ask your dealer. Write for Catalogue in case of difficulty.

**FORMO**, 23, Golden Square, Piccadilly Circus, London, W.1.  
 Head Office & Works: Crown Works, Regents Park, Southampton



**BAND-PASS ADAPTER**  
to bring your set up to date

A simple way to obtain adequate selectivity is with this Formo Band-Pass Filter designed by a leading wireless journal.

Write for free illustrated construction details.

**DUAL GANG** Cat. No. 72c **33/6**

**TRIPLE GANG** Cat. No. 69c **46/6**

## ADVERTISEMENT INDEX

	Page		Page
Belling & Lee, Ltd. ... ..	739	Mason, E. C. ... ..	743
British Pix Co., Ltd. ... ..	713	Newnes' Presentation Binder ... ..	727
Bulgin, A. F. & Co., Ltd. ... ..	739	Newnes' "Strand Magazine" ... ..	<i>Inside Back Cover</i>
Cabaret Electric Co., Ltd. ... ..	735	Picketts ... ..	743
Cossor, A. C., Ltd. ... ..	714	Pressland, Clifford, R. (Sales), Ltd. ... ..	713
Edison Swan Electric Co., Ltd. ... ..	<i>Inside Front Cover</i>	Slektun Products, Ltd. ... ..	743
Formo Co., Ltd. ... ..	748	Standard Battery Co. ... ..	743
Graham Farish, Ltd. ... ..	<i>Front Strip</i>	Technological Institute of Gt. Britain ... ..	742
Hambling, A. W., Ltd. ... ..	735	Telegraph Condenser Co., Ltd. ... ..	739
Hayberd, F. C. & Co. ... ..	742	Wates Radio Ltd. ... ..	713
Jackson Bros., Ltd. ... ..	<i>Inside Front Cover</i>	Wright & Weaire, Ltd. ... ..	733
Lectro Linx, Ltd. ... ..	735	Weedon Power Link Radio Co. ... ..	743
London Electric Wire Co. & Smiths, Ltd. ... ..	<i>Back Cover</i>		

A Gloriously Humorous Story by  
**P. G. WODEHOUSE**  
**“The Nodder”**

“Was your distant connexion Wilmot a midget?”

“No. He was a Nodder.”

“A what?”

Mr. Mulliner smiled.

“It is not easy to explain to the lay mind the extremely intricate ramifications of the personnel of a Hollywood motion picture organisation. Putting it as briefly as possible, a Nodder is something like a Yes-man, only lower in the social scale. A Yes-man's duty is to attend conferences and say ‘Yes.’ A Nodder's, as the name implies, is to nod. The chief executive throws out some statement of opinion, and looks about him expectantly. This is the cue for the senior Yes-man to say Yes. He is followed, in order of precedence, by the second Yes-man—or Vice-Yesser, as he is sometimes called—and the junior Yes-man. Only when

all the Yes-men have yessed do the Nodders begin to function. They nod.”

A Pint of Half-and-Half said it didn't sound much of a job.

“Not very exalted,” agreed Mr. Mulliner. “It is a position which you might say, roughly, lies socially somewhere in between that of the man who works the wind machine and that of a writer of additional dialogue. There is also a class of Untouchables who are known as Nodders' Assistants, but this is a technicality with which I need not trouble you. At the time when my story begins, my distant connexion Wilmot was a full Nodder. Yet, even so, there is no doubt that he was aiming a little high when he ventured to aspire to the hand of Mabel Potter, the private secretary of Mr. Schnellenhamer, the head of the Perfecto-Zizzbaum Corporation.”

Read this delightful story in the January

# STRAND

## MAGAZINE

Now on Sale

One Shilling

Obtainable at all Newsagents and Bookstalls, or post free 1/3 from George Newnes, Ltd., 8-11, Southampton Street, Strand, London, W.C.2.

# "PRACTICAL WIRELESS" DATA SHEET No. 3

## RESISTANCES

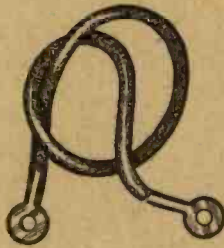

A Spaghetti Resistance

A resistance of the flexible type, known popularly as a "Spaghetti" resistance. This consists of a core of asbestos string, round which is wound the resistance wire. The ends of this winding are clamped, soldered or welded to the connecting lugs, and the winding covered with insulated sleeving. When joining these in circuit care must be taken that the connecting lugs are not pulled away from the resistance wire.

### FINDING RESISTANCE VALUES.

Resistance in Ohms =  $\frac{\text{Voltage}}{\text{Current in Amps.}}$   
 Where the current is in milliamperes, this should be expressed as the decimal fraction of an amp.  
 Example:—Resistance required to drop 50 volts at 5 mA.  
 $\frac{50}{.005} = 10,000 \text{ Ohms.}$

### GRID BIAS RESISTANCES.

For automatically biasing the grid of L.F. valves the resistance must be capable of carrying the total anode current of the valve which is biased. The value of the resistance can be found from the formula given on this sheet. The current will be the anode current of the valve, and the voltage will be the value of the grid bias required.  
 Example:—L.F. valve with 150 Volts H.T. requires Grid Bias of 10 volts, at which value the normal Anode Current is 5 milliamperes.  
 $\frac{10}{.005} = 2,000 \text{ Ohms.}$

### COUPLING RESISTANCES.

Resistances employed for Resistance Capacity Coupling must be capable of carrying the anode current of the valve and should be roughly three times the value of the impedance of the valve. The resistance employed as the grid leak of the R.C.C. stage should also be chosen in conjunction with the anode resistance and the coupling condenser. The table on this sheet gives the complete data for a number of different R.C.C. Units.

A resistance of the cartridge type. This consists of resistance wire wound on a glass, porcelain, ebonite or asbestos former, and the ends soldered to metal caps. In some cases the wire is left uncovered, and in others the whole resistance is enclosed in a casing. Some forms of resistance are now composed of a moulded material and are consequently non-inductive. This type of resistance, however, will not have the same current carrying capacity as the wire wound resistance.

When handling this type of resistance care should be taken not to drop it or otherwise subject it to severe blows, as in some types of resistance the manufacturing process leaves a brittle component which is fairly easily broken. Precautions should also be taken not to expose them to undue heat as the values may be altered with no visual indication of the alteration.

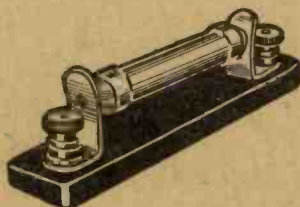

A cartridge resistance.

### DECOUPLING RESISTANCE AND CONDENSER VALUES.

Anode Current m.A.	VOLTS DROP.									
	20		40		60		100		200	
	Res.	Cond.	Res.	Cond.	Res.	Cond.	Res.	Cond.	Res.	Cond.
1	20,000	2	40,000	1	60,000	1	100,000	1	200,000	1
2	10,000	4	20,000	2	30,000	2	50,000	1	100,000	2
3			15,000	3	20,000	2	30,000	2	70,000	1
4			10,000	4	15,000	3	25,000	2	50,000	1
5					12,000	3	20,000	2	40,000	1
6					10,000	4	15,000	3	35,000	1
8							12,000	3	25,000	2
10							10,000	4	20,000	2

Correct to nearest values obtainable. The resistances used must be capable of standing the current flowing. Condensers must be capable of standing the voltage.

### R.C.C. DATA (Resistance Capacity Coupling).

Anode Resistance.	Grid Leak.	Condenser
Ohms.	Meg.	Mfd.
250,000	1	0.006
200,000	1	0.006
100,000	0.5	0.01
75,000	0.5	0.01
50,000	0.25	0.02
30,000	0.2	0.03
25,000	0.1	0.05
20,000	0.1	0.05
15,000	0.05	0.1
10,000	0.05	0.1

Values Correct to Nearest Values Listed by Makers.

When employing Resistance Capacity Coupling it is essential to incorporate a High frequency filter in the anode circuit of the Detector valve in order to ensure that no frequencies of this order pass to the grid of the following valve. This demands that the condenser must be of the mica variety, and it is also advisable to incorporate a resistance in the grid circuit of the L.F. or following valve to prevent this H.F. component from affecting the frequency response. The value of this resistance should not be greater than 100,000 ohms. An H.F. choke may be used, if desired, in place of this resistance.

### RESISTANCE WIRE.

Size.		Eureka Resistance Wire.	
S.W.G.	Inch.	Resistance per 1,000 yds. at 15.6° C. (60° F.)	Carrying Capacity for rise in Temp. of 100° C. (212° F)
		Ohms.	Amps.
16	0.064	209.4	6.0
18	0.048	371.8	4.3
19	0.040	535.6	3.7
20	0.036	661.3	3.0
21	0.032	837.2	2.8
22	0.028	1,093.0	2.2
23	0.024	1,487.0	1.8
24	0.022	1,770.0	1.5
25	0.020	2,142.0	1.25
26	0.018	2,645.0	1.0
27	0.0164	3,186.0	0.9
28	0.0148	3,914.0	0.76
29	0.0136	4,634.0	0.68
30	0.0124	5,575.0	0.59
31	0.0116	6,370.0	0.52
32	0.0108	7,350.0	0.47
33	0.010	8,571.0	0.42
34	0.0092	10,128.0	0.37
35	0.0084	12,149.0	0.33
36	0.0076	14,840.0	0.28
37	0.0068	18,536.0	0.26
38	0.006	23,808.0	0.19
39	0.0052	31,696.0	0.16
40	0.0048	37,184.0	0.15
41	0.0044	44,268.0	0.14
42	0.004	53,564.0	0.13
43	0.0036	66,136.0	0.11
44	0.0032	83,664.0	0.10
45	0.0028	108,648.0	0.08
46	0.0024	148,764.0	0.07
47	0.002	214,284.0	0.05

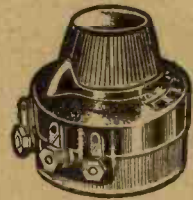

Variable resistances.

The most popular form of variable resistance. This is almost invariably provided with three terminals so that it may also be used as a potentiometer. The modern forms of this component are now made in a tapered or "logarithmic" form so that for some purposes a straight line variation of voltage is obtained.

A circular form of resistance where the wire is wound round a flat strip and the strip then bent to form practically a circle. The resistances wound in this form are made adjustable by having a rotating arm rubbing against the edge of the strip. By joining the two ends to two terminals, and the moving arm to a further terminal, a potentiometer is obtained.

### DECOUPLING RESISTANCES.

Resistances used for decoupling purposes should be chosen so that an excessive voltage is not wasted. In addition the decoupling condenser must be chosen in conjunction with the value of the resistance. The undermentioned table gives the value of decoupling resistance and condenser for different anode currents, according to the amount of voltage which may be spared.

### RESISTANCE VALUES.

Current in mA	Approximate value of resistance in Ohms.		
	To drop 25 volts.	To drop 50 volts.	To drop 100 volts.
1	25,000	50,000	100,000
2	12,500	25,000	50,000
3	8,000	16,000	30,000
4	6,000	12,000	25,000
5	5,000	10,000	20,000
10	2,500	5,000	10,000
20	1,250	2,500	5,000
25	1,000	2,000	4,000
30	800	1,500	3,500
40	600	1,200	2,500
50	500	1,000	2,000

A strip resistance. This consists of the same arrangement as shown above, with the exception that the former upon which the wire is wound is much thicker and is left in a flat condition. The ends of the wire are attached to metal lugs which are usually drilled to facilitate mounting or soldering connections. To enable adjustments of value to be obtained a small clip may be fastened round the wire with a connection taken from the clamping nut.

This type of resistance will carry much heavier currents than the other types illustrated on this sheet, owing to the large surface exposed to the air. Consequently, it is most suitable for use in mains receivers or in other places where heavy currents have to be carried. Where very fine wire is employed care should be taken that the wire is not broken, due to a knock from a screw-driver or other instrument which is employed in constructing the receiver.

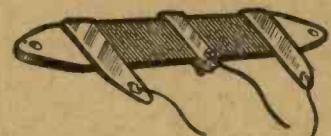

A strip resistance.





# FREE! 6 BRILLIANT CIRCUITS for the HOME CONSTRUCTOR

Designed by experts, these circuits are for amateur constructors requiring a really modern selective set which can easily be made at home.

The Lewcos Components recommended for use in the circuits assure an unparalleled degree of success in both reception and reproduction.

If not obtainable from your dealer, write to-day for your FREE copy to Radio Publicity, Section W.

Published by

# Lewcos

REGD

MANUFACTURERS OF  
MODERN RADIO COMPONENTS



**LEWCOS RADIO PRODUCTS FOR BETTER RECEPTION**

THE LONDON ELECTRIC WIRE COMPANY AND SMITHS LIMITED, CHURCH ROAD, LEYTON, LONDON, E.10

**P.W. Gift Stamp No. 14**

Printed by NEWNES & PEARSON PRINTING Co., LTD., Exmoor Street, Ladbroke Grove, W.10, and published by GEORGE NEWNES, LTD., 8-11, Southampton Street, Strand, W.C.2. Sole Agents for Australia and New Zealand: GORDON & GORCH, LTD. South Africa: CENTRAL NEWS AGENCY, LTD. *Practical Wireless* can be sent to any part of the world, post free, for 17/4 per annum; six months, 8/8. Registered at the General Post Office for Transmission by Canadian Magazine Post.