



COSSOR

MODEL 535

ALL-ELECTRIC
SUPERHET

with

**NEON
VISUAL
TUNING**

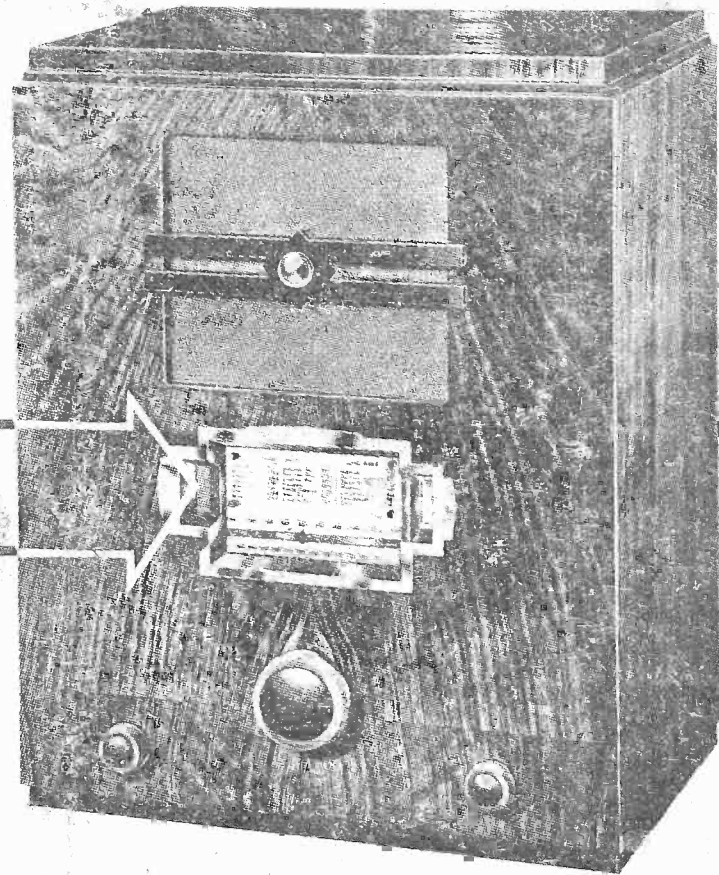

A special compensated circuit is used to eliminate fading from all worth while stations, and is combined with a Cossor Visual Neon Tuning Tube to facilitate accurate tuning and avoid distortion.

ANTI-FADING

The many other advanced features of this remarkable Superhet are fully described in Folder L.120 — send the coupon for your copy.

ABRIDGED SPECIFICATION

All-Electric Superhet Model 535 is equipped with Five Cossor Valves (inc. Rect.). Illuminated Full Vision Scale—Single Knob Tuning—Volume Control with special scale. Tone Control, 8" Energised Moving Coil Loudspeaker. Magnificently finished cabinet, 20" high, 16" wide, 10 3/4" deep. For A.C. Mains only. 200/250 volts (adjustable), 40/100 cycles.

Prices do not apply in I.F.S.

Hire Purchase Terms: 40/- deposit and 12 monthly payments of 20/-

**12
GNS.**

To A. C. COSSOR LTD., Melody Dept.,
Highbury Grove, London, N.5

Please send me free of charge, literature giving full particulars of Cossor All-Electric Superhet Model 535

Name

Address

PRAC. 5/1/35.

THIS COUPON BRINGS FULL DETAILS

L.120

6196.

THE LEADING JOURNAL FOR ALL ENGLISH-SPEAKING COUNTRIES!



Practical Wireless

EDITOR:
Vol. V. No. 120 || F. J. CAMM || Jan. 5th, 1935.

Technical Staff:
W. J. Deane,
H. J. Barton Chappie, Wh.Sch., B.Sc. (Hons.), A.M.I.E.E.
Frank Preston, F.R.A.

ROUND *the* WORLD of WIRELESS

Midland Chamber Concerts

THE first of a new series of Midland Chamber Concerts is to be given on January 11th by the Alfred Cave Quartet. It will be devoted to works by Dr. Vaughan Williams, who was born in Gloucestershire.

"The Babes in the Wood"

ON January 12th some scenes from the Fred Clements pantomime "The Babes in the Wood" will be relayed from the Theatre Royal, Nottingham. Fred Clements has been producing pantomime for twenty-eight years, and also running the Arcadia Follies at Skegness, which broadcast in the summer. In the cast of his Nottingham pantomime are Eva Bolton and Mitzi Gerald, Muriel Cronshaw, Charles Harrison and Arnold Rooke.

Concert from Torquay

MARGARET TANN WILLIAMS (contralto) will be the vocalist in the concert by the Torquay Municipal Orchestra relayed from the Pavilion, Torquay, for West Regional listeners on January 8th. Margaret Tann Williams will also sing in a concert by the Treorchy Royal Welsh Male Choir, conducted by Gwylim T. Jones, on January 10th.

"Sea Log"

THE story of a long and arduous voyage round Cape Horn will be told by Thomas J. McTear in the first talk in the series "Sea Log" from Belfast on January 5th. These talks are to be given fortnightly, and in them speakers who have followed the sea for pleasure or profit will tell of their experiences and adventures.

"The Cab"

THIS is the title of a one-act dialect play by John Taylor, which will be broadcast from Manchester to North Regional listeners on January 7th. The plot centres round the predicament in which a Northern working-class family find themselves when a rich relative decides to pay them a surprise visit, and the money cannot be found to pay his cab fare. The play is being presented by the "Chorlmores," a small dramatic society, so named because one of the two original members lived in Chorlton-cum-

Hardy, Manchester, and the other in Morecambe. The Chorlmores won third prize with "The Cab" at this year's Blackpool Drama Festival. Those taking part in the broadcast version all live in Morecambe.

"Problems of Amateur Drama"

THE North Regional talk which L. du Garde Peach is to contribute to the "Problems of Amateur Drama" series on January 8th should be of special interest, for he is to speak on "Writing a Play," and it is as a dramatist rather than a producer that Peach is known throughout the country.

SOME OF THE CONTENTS OF THE JANUARY ISSUE OF

Practical Mechanics

Gd. from all Newsagents.

Marvels of the Cinema Organ—Guiding Aircraft by Wireless—Principles of Electric Motors—Aerial Gunfire Camera—Building a 15 c.c. Petrol Engine—How Maps are Made—Pearl Diving—Home-made Burglar Alarms—Experiments in Photo Electrics—Model Making—Novelties, New Tools, Etc., Etc.

"Microphone Tour"

NORTH SHIELDS will be the scene of the next North Regional "Microphone Tour" on January 11th, when one of the biggest ship-repair yards in the world is to be visited. Microphones installed at various points of vantage will enable listeners to hear the great compressors working the sluices which fill the docks with water, and the sound of the men at work. Workmen, some of whom have seen forty years' service in the yard, will be interviewed in front of the microphone, and Mr. James Patten, the General Manager, will recall some of his earlier experiences.

Military Band Concert

THE Military Band of the Queen's Own Yorkshire Dragoons (Territorial Army) will broadcast a concert from Leeds on January 11th. The conductor is Lieutenant H. F. Fulford.

A Novel Musical Show

A MUSICAL show of novel character is being devised and got together for January 17th by Mr. Austen Croom-Johnson, who is also arranging the music. The show will be something like a news reel of the shows playing in town—a rapid-moving musical half-hour composed of musical medleys of the film and stage hits of the moment.

Literary Criticism Talk

THE third talk in the series Literary Criticism for Welsh listeners will be given by Iorwerth C. Peate on January 7th. Mr. Peate is well-known to listeners for his Welsh talks. He is Assistant Keeper in Charge of the Sub-Department of Folk Culture and Industries at the National Museum of Wales.

The Robert Burnett Choir

THIS popular choir, which will be heard on January 10th, needs no introduction to listeners. This choir, though only formed in 1931, has already made a place for itself in British musical circles, and many of the finest Scottish airs are included in its repertoire, some of these arranged by Mr. Burnett himself.

"St. Simeon Stylites"

ON January 6th, for the first time on Midland Regional, a short play is being given. The innovation is likely to be popular with many listeners, but the plays will, of course, have to be chosen carefully. For this broadcast, the play is to be "St. Simeon Stylites," by F. Sladen-Smith of the Unnamed Society, Manchester, who is the author of a number of successful plays. The scene is St. Simeon's tower, and there the saint, in interviews with various mortals and the devil himself, expresses his views on the state of the world. The players are from the Malvern Repertory Company, and the relay is from The Festival Theatre, Malvern.

ROUND the WORLD of WIRELESS (Continued)

Cornish Conversations

ON January 5th the West Regional will broadcast an Old Christmas Eve programme in which we shall hear Cornish conversations. The proceedings are interrupted by carol singers and by the Madron Guise Dancers. Madron is a little village near Penzance, where Guise Dancing still survives. In the old days the Guise Dancers went their rounds for the twelve days of Christmas, bursting into the houses of all and sundry, performing their version of the old St. George Play, and demanding refreshments and money.

Talk for Western Farmers

IN the feature "For Western Farmers in Particular" on January 3rd, for West Regional listeners, A. W. Ling, Agricultural Officer and Chief Advisory Chemist for the University of Bristol, who has taken part in many of the discussions, will give a talk on some topical subject of interest to farmers.

County School Choir

THE Hawarden County School Choir, conducted by Fred Roberts, will be heard in a concert relayed from the County School, Hawarden, Chester, for West Regional listeners on January 4th. This choir gave its first broadcast shortly after winning the first place in the National Eisteddfod at Wrexham.

"Gypsy Call"

FOR the Children's Hour, on January 5th, which goes to all Regionals, Midland is putting on a Romany srenade, "Gypsy Call." The author, Norman Timmis, has had over one hundred plays and sketches broadcast.

"The Empire at Work"

AN interesting series of talks commenced with the New Year entitled "The Empire at Work." These will be broadcast on Sundays at 6.45 p.m. once a month. It has been found that listeners take great interest in hearing of the everyday work of their listening neighbours, whether near or far away, a tendency that leads to a greater understanding of the daily trials of life. This neighbourly insight into other people's work is being extended to a wider sphere. It is proposed to obtain broadcasts by people working in various parts of the Empire, eventually all countries and districts of the Empire being covered. A listener hearing all these talks will obtain a wider view of Imperial conditions, countries, habits and customs. For instance, there may be a talk on "Daily Life in the Sudan" or "Steps on the Way to India," the latter giving a view of what the worker in the Indian Empire sees on his way out to his job.

Details of the work in tea gardens, coffee plantations, rubber plantations, the Malay Straits, on the veldt in Africa, and so on, in fact, all over our far-flung Empire, are to be included. As it is one of the missions of broadcasting to shorten the distance between the Dominions and Colonies and the Homeland, so it becomes the broadcast medium to bring the lives of Imperial workers into closer relation. Hence this series of talks: "The Empire at Work."

INTERESTING and TOPICAL PARAGRAPHS

Variety Programme

ON January 10th, listeners will hear a programme given by six versatile variety artists: the Radio Three (girls) and Jack Lorrimer, Ronald Hill and Clive Errard (three men). The Radio Three appeared in "Wonder Bar" and "The Show Goes Over," and the men have

appeared in various variety productions. The peculiarity of this Sextet is that they each do all kinds of parlour tricks; not only singing and giving monologues, but three are solo pianists, others play various instruments and sing in all kinds of ways which modern radio demands. They will give a programme of sextet arrangements, solo comedy songs and various rhythm pianoforte arrangements for one, two and three pianos. The show will be compered and strung together, and a bright radio entertainment is aimed at.

A NOVEL XYLOPHONE.



Over 500 people, including Mr. and Mrs. Percy Edgars (Midland Regional Director of the B.B.C.), attended the Exide Dance held on December 5th at Tony's Major Ballroom, Birmingham. One of the attractions in the Cabaret was 14-year old Stanley Raulins, who played, among other instruments, a xylophone made from Exide wireless battery boxes.

SOLVE THIS!

PROBLEM No. 120.

Greenbank built an A.C. receiver to a published design using a power pentode in the output stage. When new the set functioned satisfactorily, although it was observed, on taking measurements, that the anode current taken by the pentode was higher than the average figure given by the makers. After the set had been in use for about a week, however, there was a sudden falling-off in signal strength as well as a deterioration of quality, whilst it was observed that there was a blue glow inside the pentode valve. Upon replacing the pentode by another of similar type there was a repetition of the previous experience. What was wrong? Three books will be awarded for the first three correct solutions opened. Mark your envelopes Problem No. 120 and address them to: The Editor, PRACTICAL WIRELESS, Geo. Newnes, Ltd., 8-11, Southampton Street, Strand, London, W.C.2. Entries must be received not later than first post on Monday, January 7th.

Solution to Problem No. 119.

Robertson had overlooked the fact that, although the chassis was metallised on both sides, the two surfaces were not electrically connected together.

No correct solutions of Problem No. 118 have been received, and consequently no books have been awarded.

A Ghost Story

A GHOST story specially written for the microphone by Lord Dunsany will be broadcast on the Regional wavelength on January 4th. This is the season of the year for ghost stories, and one by such an eminent author, so well-known to the radio audiences, is doubly welcome. This latest creation of Lord Dunsany is called "The Return."

"Soft Lights and Sweet Music"

THIS is the title of a programme of memories of the previous broadcasts under this title, which will be given on January 3rd. Austen Croom-Johnson, who is presenting the entertainment, says that he is trying to use each composer who has contributed to the series and include his most representative writings. The twenty minutes' programme will be filled with melody and rhythm, and as its title proclaims, will be easy to listen to. The cast will be: Austen Croom-Johnson, John Burnaby, Eric Siday, Reginald Leopold, Bill Shakespeare, Albert Harris and Elizabeth Welch.

"Goody Two-Shoes"

ON January 9 an excerpt from the pantomime "Goody Two-Shoes" will be broadcast from the Scottish Regional.

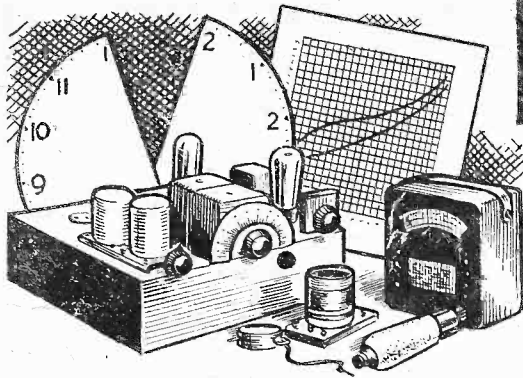

HALF-HOUR EXPERIMENTS

By FRANK PRESTON

It is always a good plan for the experimenter to cultivate the habit of taking as many readings as possible of voltages, currents, resistances, capacities, and so on. Having made a note of some of these readings, any faults which may develop can nearly always be traced and corrected in a minimum of time. In addition to this advantage, however, the taking of measurements often gives an insight into the functioning of components that might otherwise never correctly be understood.

The value of voltage and current measurements will be more fully appreciated when it is pointed out that many of the largest firms of receiver manufacturers issue to their service engineers charts showing the readings that should be obtained between various points in the receiver. Having this data before him, the engineer can rapidly narrow down his search for faults, should they occur, and he is able to effect a remedy in a very short time.

Necessary Instruments

It might be considered that an array of expensive instruments would be required to take the necessary measurements, but this is not the case, although it is certainly worth while to buy a good combination instrument, such as the Pifco "Rotameter," the "Dix-onometer," or the "Avo-minor," when funds permit. Nevertheless, a considerable amount of interesting work can be carried out with nothing more complicated or expensive than a moving-coil milliammeter which gives a full-scale deflection on 5 milliamps. A reliable meter of this type will cost about 30s., but it is better to spend this amount on one good meter than on two or three moving-iron instruments of only moderate accuracy.

The first readings which should be taken are those of the anode current to each of the valves, the milliammeter being included between H.T. positive and the anode-circuit coupling components; the positions of the meter in a typical three-valve variable-mu-det.-P. circuit are indicated on the circuit diagram in Fig. 1. If these readings are taken when the set is new, or when it is known to be operating efficiently, they may be taken as "standards" so that comparisons can be made later when the receiver is not operating as it should. Quite apart from this, however, the readings are useful because they can be compared with the anode-current figures given by the valve-makers, or shown on the characteristic curves.

Current Indications

Let us briefly consider the readings which should be obtained in the case of a set of the type represented by Fig. 1. When the milliammeter is included in series with

The Experiments this Week Concern the Taking of Current and Voltage Readings at Various Points Throughout the Receiver.

the anode circuit of the variable-mu valve in the position marked A, the current should

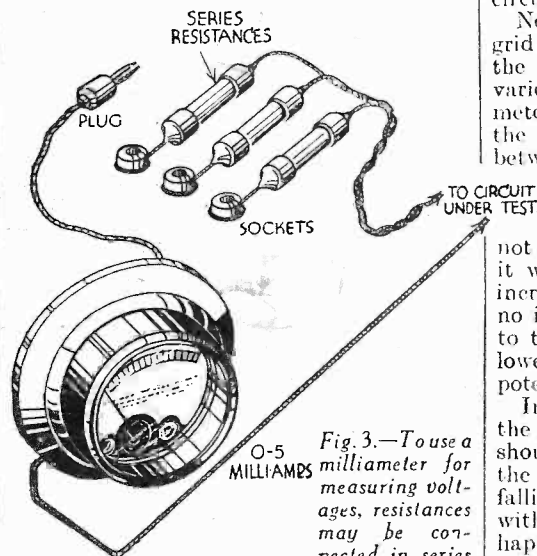

Fig. 3.—To use a milliammeter for measuring voltages, resistances may be connected in series as shown here. The arrangement illustrated shows a method of obtaining various voltage readings by employing alternative resistances. vary from about 1 milliamp. up to 5 or 6 milliamps, as the volume-control potentiometer is adjusted. If the current remains

the same regardless of the position of the potentiometer slider, it will be evident that either the G.B. circuit is broken or it is short-circuited—perhaps due to a fault in the by-pass condenser connected between the "bottom" of the grid coil and earth. In the case of a main set the same result would be observed if the by-pass condenser across the bias resistance in the cathode circuit were short-circuiting.

Next insert the meter in the screening grid lead, as shown at B, and again note the readings as the grid-bias voltage is varied. It is important to ensure that the meter should be on the "H.T.+" side of the by-pass condenser, because if it is between the condenser and the screening grid a false reading would probably be obtained, and the set might become unstable. The current will not generally exceed 1 to 2 milliamps, and it will fall to almost zero as the bias is increased. If it were found that there was no indication of current, this would point to the fact that the by-pass condenser or lower half of the fixed screening-grid potentiometer was short-circuiting.

In the case of a receiver having A.V.C., the readings in both cases mentioned should vary according to the strength of the signals being received, the current falling off as the set is brought into tune with a signal. If the A.V.C. system happened to be at fault, the current would remain steady.

The Detector Circuit

With the meter in the position marked C the anode current of the detector valve can be measured. The value of this current

(Continued overleaf)

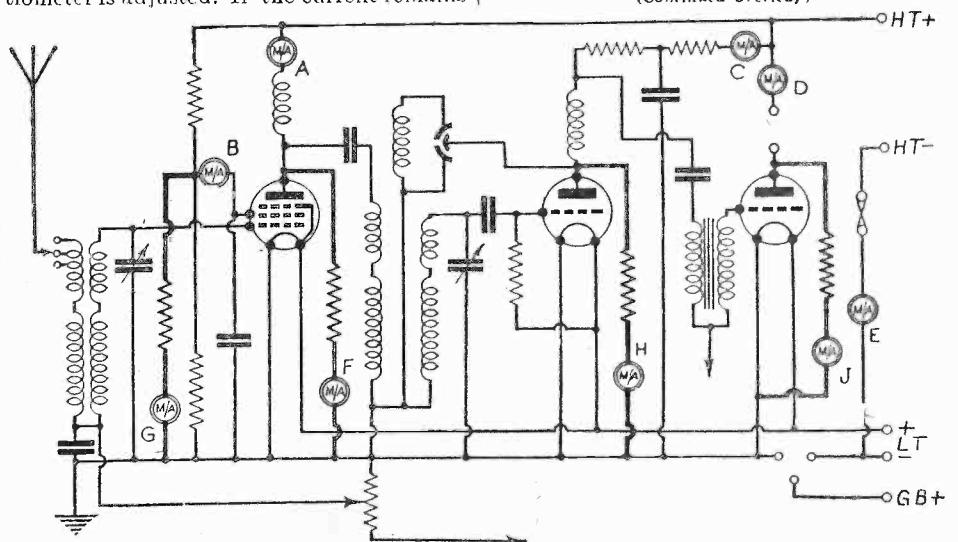

Fig. 1.—This is a typical three-valve circuit on which are shown (in heavy lines) the positions of the milliammeter and series resistance when taking the various measurements described in the text.

(Continued from previous page)

will depend very largely upon the ohmic resistance of the decoupling resistor and the type of valve. Generally, in the case of a normal type of detector valve, the reading should approximate to 1 milliamp. in a battery set, and 2 to 3 milliamps. in a mains set. The needle should remain almost stationary, regardless of the signal tuned in, but (assuming that leaky-grid detection is employed) a slight drop in current will occur when the set is tuned to a very strong signal; the change will, however, be so slight as not to be recorded unless the meter is of a very sensitive type having a low maximum reading. Another point that might be watched with the meter in this position is the change in current as the set is brought into oscillation; the needle will probably move slowly down the scale as reaction is increased, and then give a sudden and slight downward "kick" as the oscillation point is reached. The same idea, incidentally, applies to the H.F. and L.F. valves, which should not, of course, fall into oscillation at any time. If oscillation is suspected, the grid terminal should be touched with the finger, the needle of the meter being watched meanwhile. If the current rises as the grid terminal is touched, this will be a sign that the valve was oscillating.

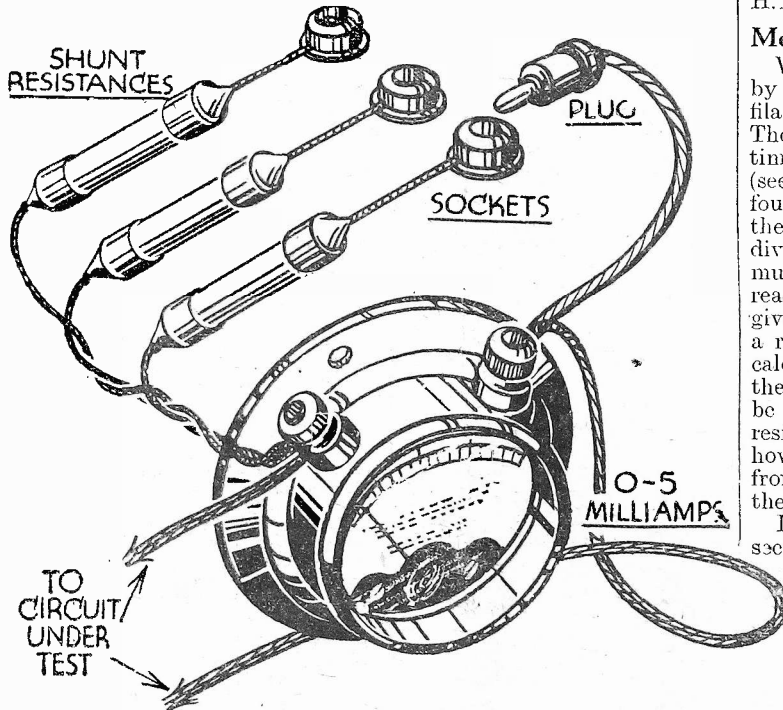

Fig. 2.—This drawing shows how different resistances may be connected in parallel with the milliammeter to enable heavier currents to be measured.

An Indication of Overloading

The reading with the meter inserted in the anode lead to the power valve will show whether or not the bias voltage has been adjusted properly, and will indicate—if the current is too high—if the bias resistance or G.B. battery is short-circuited. When a transmitter is tuned in, the current reading should be reasonably steady, although the needle is almost sure to flicker slightly as the intensity of sound from the speaker varies. If the needle gives a violent upward "kick" when a loud passage is reached or a loud note

The maximum current in this case will probably be so high as 35 milliamps., and for this reason the meter must be modified to deal with such high currents. The modification consists of connecting a fixed resistor in parallel with the meter terminals (see Fig. 2). The value of resistor required depends upon the internal resistance of the meter, and the full-scale reading may be doubled by connecting in parallel a resistor having the same value as the meter—this value is usually marked on a good instrument. In the same manner, the readings can be trebled by using a resistance equal

to half the value of the meter, quadrupled by using a resistance of one-third the value, and so on. The required resistance can easily be made as described in PRACTICAL WIRELESS dated December 29th, 1934.

After measuring the H.T. current taken by the individual valves, the total anode current should be measured by inserting the meter in series with the H.T. negative lead, as shown at E in Fig. 1. The reading should now be equal to the sum of all those taken before, plus the current passed by the fixed screening-grid potentiometer. Should the current now appear to be greater than before, it will be evident that there is a short-circuit at some point in the H.T. supply:

Measuring Voltages

Voltage reading can next be taken, starting by measuring the voltage applied to the filament terminals of the valve-holders. The milliammeter can again be used, this time by joining resistors in series with it (see Fig. 3). The value of the resistor is found by applying Ohm's Law, which gives the value as being equal to the voltage divided by the current in milliamps. and multiplied by 1,000. Thus, if the meter reads up to 10 milliamps., it can be made to give a maximum reading of 4 volts by using a resistor of 4,000/10, or 400 ohms. This calculation does not take into consideration the resistance of the meter, but that can be ignored in many instances. Should the resistance be more than about 40 ohms, however, this figure should be subtracted from the calculated value before winding the series resistor.

It is always a rather difficult matter to secure an accurate measurement of anode voltages in working conditions, because the meter must be connected in parallel with the various valves. When this is done the current consumption is increased and the apparent voltage is less than the true figure. The readings will be sufficiently accurate for most purposes, however, if a meter of the type considered above is used

in conjunction with a series resistance. For example, if the full-scale deflection is to be altered from 10 milliamps to 150 volts, the series resistance should be 15,000 ohms, and this will not alter the voltage very much. In any case a sufficiently accurate reading can always be obtained by taking the average of two readings, one taken with the valve in its holder and the other when it is removed. Voltage readings can be taken for the anodes and screening grid of the valves by connecting the meter in the positions marked F, G, H, and J in Fig. 1.

Musical and Dramatic Programme

ON January 7th, there is a musical and dramatic programme given by young Midland artists for Midland Regional listeners. The soloists are Hurst Burton (baritone), who sang Laporello in the Midland Institute performance of "Don Giovanni" in May last; Eric Hope (pianoforte), who won the Federation of British Music Industries Challenge Cup two years ago when he was seventeen; and Audrey Thompson, a local violinist of distinction. The Harold Brighouse comedy "The Oak Settle," is to be acted by the Shakespeare and Dramatic Society of the Midland Institute, Birmingham, and produced by Stuart Vinden, at whose classes at the Midland Institute the players have been trained. This Dramatic Society is one

Programme Notes

of the oldest in the Midlands. In its present form it dates from 1899. Two of its original members were in the Pilgrim Players, who were the forerunners of the Birmingham Repertory Company.

"Sights and Seers"

A NEW series of four talks by Edmund Vale will be given under the general title of "Sights and Seers." This series for West Regional listeners will deal with man's reactions, adequate or inadequate, to natural beauty and the first talk will be given on January 11th. Before going to

the University Mr. Vale studied engineering and did two years' practical work in the shops.

Sports Talks

THESE talks, which are to be given during January, February and March, 1935, have an interesting change of angle. Since all games give employment as well as amusement, the talks next spring will be divided between the actual player and those who look after his needs. Besides the usual talks by rowing men, golfers and football players, there will be talks by a billiards marker, by a race-horse trainer, a pit manager of a team of racing cars, and the trainer of a First Division football team. In addition, there will be a collection of eye-witness accounts of the chief matches in the third round of the Cup-ties.

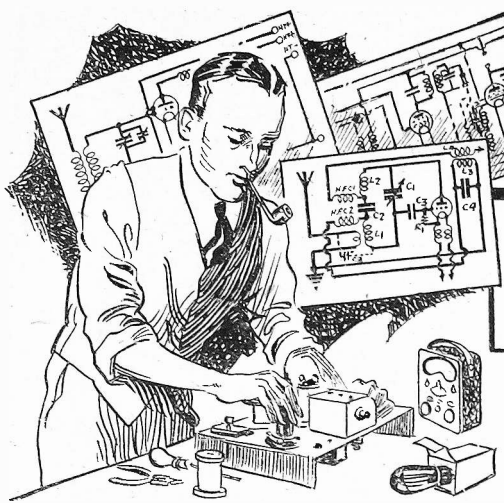

CIRCUITS AND SETS FOR ALL

A Popular Three-valve Arrangement is Dealt with this Week, the Receiver Being Designed for Use with Plug-in Coils of Standard Type.
By BERNARD DUNN.

THE receivers dealt with in the first two articles of this series have been of types which require for their construction modern components of fairly critical values. By way of a change, and in response to numerous requests, it is therefore proposed this week to take rather a different line in describing a simple three-valver using plug-in coils, of which several readers have a number on hand. This does not mean that the set will be of an old-fashioned pattern, or that it will be unselective and thus inadequate for modern requirements; the circuit has been designed to overcome any possible difficulties of this sort.

A Popular Valve Combination

The arrangement of valves comprises the ever-popular detector and two low-frequency combination, the first L.F. valve being coupled to the detector on the resistance-capacity system, and an L.F. transformer being used between the first and second stages. Contrary to general practice, the detector is connected to function on the anode-bend principle in order to secure the greatest possible degree of selectivity whilst retaining three-electrode valves. The complete circuit to be described is reproduced on this page, and the simplicity need not be emphasised, for it can be seen that the necessary connections are few in number, and all the components are of well-tried and popular type.

The aerial is coupled through a .0003-mfd. pre-set condenser to one terminal of a two-pole change-over switch, which serves to bring into circuit a long- or medium-wave coil as required. This removes the necessity for coil-changing, excepting when a wavelength range outside of that employed by the majority of broadcasting stations is required. Both of the tuned-aerial coils are of the centre-tapped type and, therefore, give reasonably good selectivity. In the interest of simplicity a single reaction coil is used, this being a size 75, although a slightly different coil might in some in-

necessary to include an H.F. choke in the detector-anode circuit, but to avoid the possibility of H.F. currents getting through into the L.F. amplifier a .0002-mfd. fixed condenser is joined between the detector anode and earth.

A comparatively modern refinement is to be found in the provision of decoupling in the detector circuit, a 10,000-ohm resistance and 1-mfd. fixed condenser being included for this purpose. The L.F. valve is not of the power type, because the input to it is not great, so that fairly high amplification is of greater importance than signal-handling capacity. In order to ensure really good reproduction it is essential that the transformer (L.F.T.) between the second and third valves should be of a good pattern, having a primary winding of high inductance and reasonable current-carrying capacity; it is for these reasons that a rather expensive—but extremely

The aerial is coupled through a .0003-mfd. pre-set condenser to one terminal of a two-pole change-over switch, which serves to bring into circuit a long- or medium-wave coil as required. This removes the necessity for coil-changing, excepting when a wavelength range outside of that employed by the majority of broadcasting stations is required. Both of the tuned-aerial coils are of the centre-tapped type and, therefore, give reasonably good selectivity. In the interest of simplicity a single reaction coil is used, this being a size 75, although a slightly different coil might in some in-

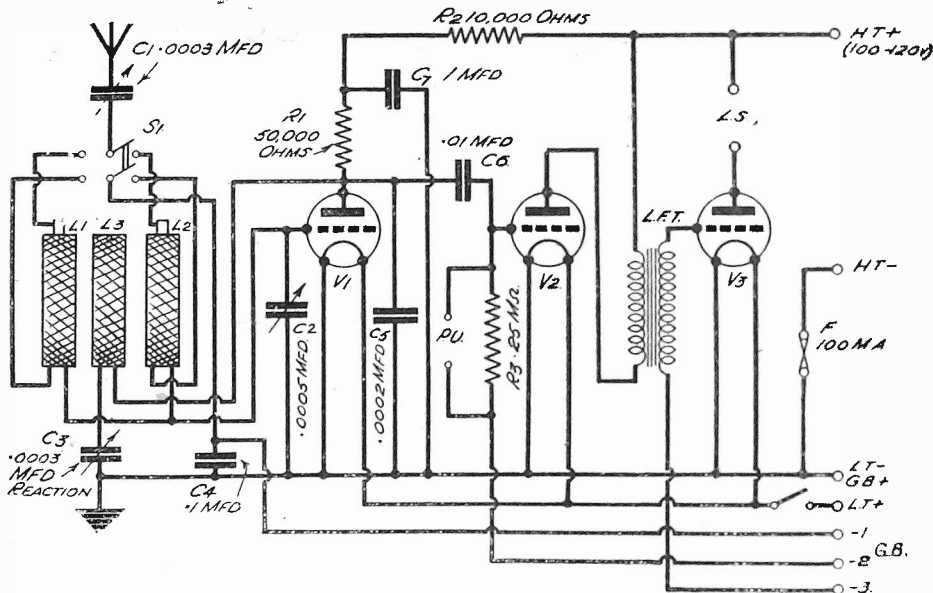

This is the three-valve circuit, for use with plug-in coils, that is described on this page.

LIST OF COMPONENTS.

- One Metaplex Chassis, 12in. by 10in., with 3in. runners (Peto-Scott).
- One Ebonite or Plywood Panel, 12in. by 8in. (Peto-Scott).
- Three Fixed Coil Holders (any good make).
- Three Plug-in Coils; sizes 60X, 75 and 200X (L1, L2 and L3) (any good make).
- One D.P.D.T. Toggle Switch (S1) (Bulgin, Type S.89).
- One S. Pole Toggle Switch (S2) (Bulgin, Type S.102).
- One .0003 mfd. pre-set Condenser (C1) (Formo).
- One .0003 mfd. Reaction Condenser (C3) (Graham Farish).
- One .0005 mfd. Tuning Condenser with Dial (C2) (Ormond).
- One .1 mfd. Tubular Condenser (C4) (T.M.C.).
- Three 4-pin Valve-holders (Clix).
- One .0002 mfd. Tubular Condenser (C5) (T.M.C.).
- One .01 mfd. Tubular Condenser (C6) (T.M.C.).
- One 1 mfd. Fixed Condenser (C7) (T.M.C., Type 25).
- One 50,000 ohm Fixed Resistance (R1) (Ferranti, 1/2 watt).
- One 10,000 ohm Fixed Resistance (R2) (Ferranti, 1/2 watt).
- One .25 megohm Fixed Resistance (R3) (Ferranti, 1/2 watt).
- One 100 m.a. Fuse and Holder (F) (Microfuse)
- One Low-frequency Transformer (L.F.T.) (Ferranti, A.F.3).
- Terminals, connecting wire, wander plugs, etc.
- One 210 L.F. Valve (V1) (Cossor).
- One 215 P. Valve (V2) (Cossor).
- One 220 P. Valve (V3) (Cossor).

stances be desirable, especially if the detector valve is not of the type specified.

Capacity Reaction

Tuning is carried out by the .0005-mfd. variable condenser marked C₂, and reaction is controlled by C₃, which has a capacity of .0003 mfd. Since anode-bend detection is used the usual grid condenser and leak are not required; instead, a lead is taken from the "earth" ends of the tuning coils to a tapping on the G.B. battery, a .1-mfd. by-pass condenser completing the high-frequency circuit. Resistance-capacity coupling being used between the detector and first L.F. valves, it will be found

reliable—component is specified for this position. Do not attempt to save a shilling or two by using a second-hand transformer which has entirely different characteristics, and which is probably intended to be resistance-fed.

The loud-speaker terminals are included directly in the anode circuit of the third valve, since the set is intended to operate a sensitive moving-coil speaker; an older, moving-iron speaker could be used, but this would not prove nearly so satisfactory for good reproduction of the nearer transmitters. As a safety measure a 100-m.a. fuse is inserted in the H.T. negative lead, but this is, of course, quite optional.

(Continued overleaf)

(Continued from previous page)

Arranging the Components

It is scarcely necessary to give a lengthy description regarding the most suitable disposition of the parts, since those who are in possession of plug-in coils are probably by no means new to home construction. A metallised chassis is, however, recommended, and the three coils may be mounted in fixed coil holders near the left-hand end of this. The holders should be so placed that the coils are about $\frac{1}{2}$ in. apart when inserted, and the two-pole wavechange switch should be placed on the panel as near as possible to the coils. The valve-holders might well be placed in a line near the back of the chassis, the transformer and coupling components being placed on the under side near to the valve holders to which they are connected. A symmetrical panel

layout will be obtained by placing the tuning condenser in the centre and towards the top of the panel, with the reaction condenser immediately below it. The on-off switch can then be situated to the right of the panel to match up with the wave-change switch.

Altering the G.B. Voltage

The holders for the two tuning coils (L1 and L2) should be placed so that both pins and sockets are to the back and front respectively of the chassis; if this is not done it will be found that reaction is inoperative on one waveband.

After wiring up, the battery leads should be connected to tappings on the batteries which give the voltages shown in the diagram and the set switched on. Should it be found that the detector valve refuses to oscillate the connections to the reaction-coil

holder should be reversed. Once this has been attended to it should be possible to receive a number of transmissions at good strength, but it will be well to try the effect of reversing the connections to the accumulator. The object of this is slightly to vary the G.B. voltage applied to the detector, since it is impossible to vary this in smaller steps than $1\frac{1}{2}$ volts by any other means.

The degree of selectivity can be varied over a wide range by altering the capacity of the pre-set aerial condenser, and an adjustment should be found that permits of good reception and the required selectivity on both wavebands.

It will be seen from the circuit that provision is made for connecting a pick-up in the grid circuit of the first L.F. valve, these connections providing an ample amount of amplification to ensure that the last valve is fully loaded.

WIRELESS IN AFRICA

Details of the Wireless Equipment Recently Fitted to Junkers Aircraft

THE Marconi Company have installed special radio equipment in the Junkers aircraft recently delivered to South African Airways. Three of the larger aircraft are fitted with transmitting

Ranges between the machines in flight were up to 130 miles by telephony and 200 miles by telegraphy. "Homing" was also successfully used on most stages of the flight.

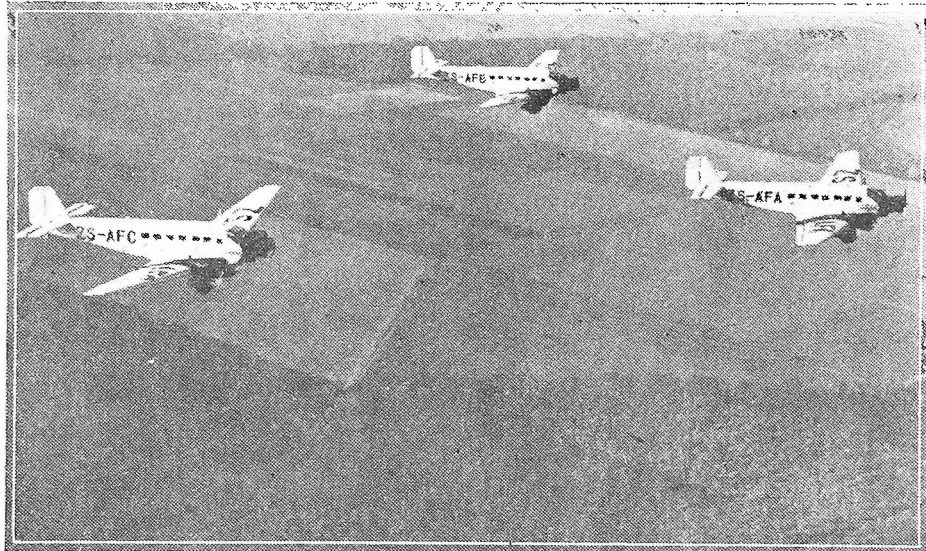

Junkers aircraft for South African Airways photographed in flight. The photograph below shows the medium- and short-wave transmitting and receiving equipment.

and receiving equipment Type A.D.37/38, suitable for telephony and telegraphy on both medium and short wavelengths, and will link up with the present London-Cape Town air route, while a number of smaller aircraft, operating internal routes, are fitted with the new Marconi medium wave sets Type A.D.41/42. All are to carry Marconi directional receivers as an aid to navigation. The Marconi Company provided an experienced engineer and two expert operators to accompany the aircraft on their delivery flight from Europe to South Africa, during which excellent wireless working was attained on all machines.

On the medium waves, they gave a practically uniform performance of two-way communication over 600 miles on continuous wave telegraphy, while on short waves (with the A.D.37/38 equipments), good telegraph working was carried out with Victoria West over 1,200 miles and two-way telephony over 1,000 miles.

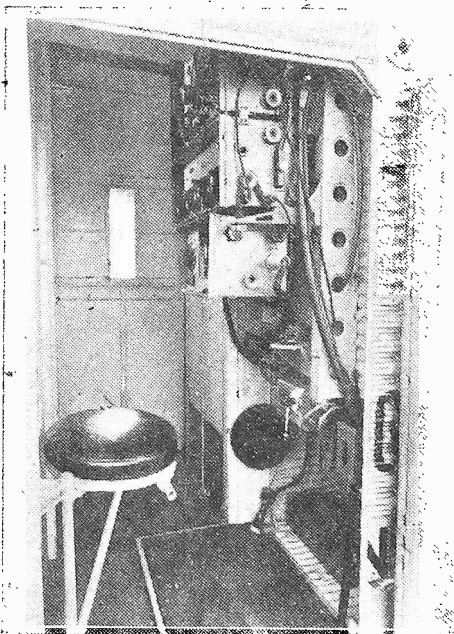

REMARKABLE LONG-RANGE WIRELESS

INTERESTING reports have been received from time to time of long-range wireless reception between British air-liners and ground stations, and also between aircraft in flight.

For instance, quite recently an amateur operator residing at Victoria West, Cape Province, South Africa, picked up messages sent out by the air-liner "Astræa," of Imperial Airways, when that machine was flying between Alor Star and Singapore, in Malaya. The distance between the aircraft in flight and the station picking up the message was approximately 5,200 miles.

Radio Messages from Air-liners

The signals from the air-liner, which were routine messages on a short wavelength transmitted while the machine was making a night flight, were received so well by the amateur at Victoria West that they came through at loud-speaker strength. Such long-distance reception is all the more remarkable when the fact is taken into consideration that the air-liner's power output is only 60 watts. Not long ago, while one of the aircraft on the Africa air mail was flying near Mpika, its operator got into wireless touch with another aircraft on the same route which, at the time, was flying at a point 2,000 miles distant, communication being maintained for several minutes without fading or interference. On another occasion, while an Imperial Airways machine was making an aerodrome survey along the route from England to Australia, its operator established communication with the Sydney wireless station at a time when the aircraft was in flight at a point over 5,000 miles from that city.

Over the Nile

On another flight, during tests with an improved type of short-range wireless apparatus, a machine while flying above the White Nile, between Juba and Kampala, managed to establish communication over a distance of 4,000 miles with a station in England. During the same trials one of the operators, while over Central Africa, picked up and could hear quite plainly a news broadcast from a station at Miami, Florida. Long-range contacts were also established with stations in Germany and Italy; while Cairo received short-wave messages, without any fading, from a machine more than 1,000 miles away, flying southward towards Cape Town.

SECRETS OF THE VALVE GRID!



Lengths of grid for Mullard valves, as they come from the grid-making machine.

SOME irreverent journalist once described an electric lamp as a "hair-pin in a bottle." If he had seen one of the original radio valves used in the early days of broadcasting he would probably have called it a hair-pin and a thimble in a bottle. He would not have been far wrong except that he would have omitted another and most important part of the make-up of a valve. For between the hair-pin or "filament"—to give it its correct name—and the thimble which the technical man calls the "anode," is a third metallic object consisting of a spiral of thin wire and dignified with the name of "grid."

The above brief description is intended to convey the impression of a pear-shaped glass bulb in the interior of which projects a glass stem carrying a number of stout horn-shaped wires. Across the tips of some of these horns zigzags a thin wire—the filament. Surrounding this, and supported by other horns is a flattened spiral of wire—the grid; and surrounding all is the anode, which in some valves is cylindrical, but in the Mullard battery valve illustrated is a flat metal box with open ends. This, of course, is held in position by more wire horns.

It should be explained that in the final stages of manufacture all the air is removed from the bulb.

Filament, anode, and particularly the grid, play an important part in the amplification and detection of radio signals, but although the secrets of the grid are wrapped in mystery to many people, the process is, in fact, surprisingly simple.

The Filament

The filament, which is nothing more than a small electric lamp lighted by the low-tension battery of the set, is made of a specially-prepared wire which, when heated, possesses the property of throwing off immense clouds of tiny negative electrical charges called "electrons." These electrons are strongly attracted by the anode which, in the receiver, is connected to the positive side of the high-tension battery, and the stream of electrons proceeding from the filament to the anode within the valve and through the external circuit constitutes an electric current.

If the valve possessed no grid this anode current would be of a perfectly steady value—in capable of operating a loud-speaker; and it is entirely due to the presence of the grid that the modern receiving valve can assist in interpreting the radio programmes.

To the grid is led the incoming signal which consists of rapid fluctuations of electric pressure corresponding exactly with

the sound-waves produced in the broadcasting studio before the microphone. This varying pressure applied to the grid has the effect of impressing corresponding variations in the flow of electrons, that is to say in the strength of the anode current. Since the valve is so designed that comparatively small changes in signal strength produce comparatively large changes in the anode current, the valve serves as an amplifier.

According to the way in which the receiver circuit is designed, the valve may be used to amplify the signal just as it is received by the aerial; to "detect" it, which means changing it to a form which can operate a telephone instrument or speaker; or to amplify it further after detection in order to increase the volume of sound.

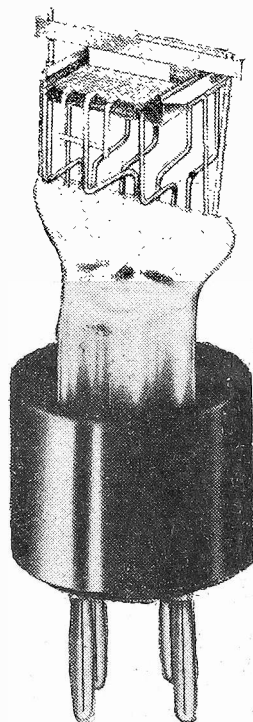

Mullard battery valve with top half of anode removed to show filament and grid.

The simple valve with a single grid just described is used in a large number of sets as a detector or as a final amplifier, but there are many other classes of valve having more than one grid.

Multi-grid Valves

The well-known "screen-grid" valve has two grids, and was introduced some years ago as a more efficient type of high-frequency amplifier for magnifying the signals as picked up by the aerial. Pentode valves have three grids and were first introduced by the Mullard Company in 1928 as final amplifiers or loud-speaker valves. They give a much greater degree

And the Important Part it Takes in a Modern Valve

of amplification and bigger volume than the ordinary three-electrode valve. More recently a modified form of pentode, known as the screened pentode, has been introduced for high-frequency amplification and gives a greater degree of magnification than any screened grid valve.

The very latest development is the Mullard Octode which has no fewer than six grids, one within the other. This is used in what is known as the "frequency-changing" stage of modern super-het. receivers, its function being to change the original radio-frequency signal to a lower frequency at which it can be still more efficiently amplified, usually by a screened pentode.

The accuracy with which valves of this type are assembled can be gauged from one of the accompanying illustrations, which shows the interior of a Mullard Octode in which the six concentric grids, each accurately spaced and isolated from the others, occupy a space considerably less than $\frac{1}{4}$ in. in diameter.

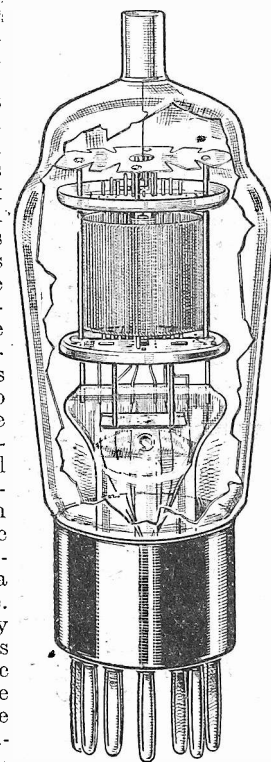

A Mullard Octode which has six grids.

The Peto-Scott S.G. Three

ON page 454 of PRACTICAL WIRELESS dated December 8th we described an excellent three-valve battery receiver lately introduced by Messrs. Peto-Scott and called the S.G. Three.

Our description, however, gave the impression that this receiver was supplied in kit form. Actually, this instrument is sold only as a complete ready-assembled receiver, the price being £6 6s. cash. It can be obtained on easy-payment terms for 5s. down and 18 monthly payments of 7s. 9d.

**PRACTICAL MECHANICS
6^D EVERY MONTH.**

A DEVICE FOR "SEEING" SOUND!

This Simple Instrument Enables One to See, on a Translucent Screen, the Strange Effects of Sound Waves, and the Endless Variety of Patterns, Many of Them Curiously Beautiful, that are Produced by the Incoming Music and Speech in a Wireless Receiver.

WITH the interesting instrument described here a new field is opened for the amateur wireless experimenter. The Voxometer is made by placing a small loud-speaker unit in a tin container, as illustrated in the sketches. A half-pint paint tin, or round cocoa tin, will answer the purpose admirably. Two tin brackets are soldered to the can to secure it to the baseboard. Molten paraffin wax is poured into the space between the tin can and the loud-speaker unit, in order to produce a dead sound chamber between the loud-speaker unit and the rubber diaphragm.

The Diaphragm

To obtain the best results the diaphragm must consist of very thin rubber. In the original Voxometer, rubber from a toy rubber balloon was used, strong rubber bands being used to bind it over the top of the can.

The degree of tautness of the rubber diaphragm will depend somewhat upon the power of the loud-speaker, and the current fed into it, but a little perseverance will produce the desired results.

Owing to the fact that a small pool of mercury is placed on the rubber diaphragm, it will be necessary to make a slight depression in the centre. This can be done by fixing a small iron weight in the centre.

The Cabinet

This is constructed of plywood with a three-quarter inch soft-wood base. The

window in the front is cut out with a fret-saw and provided with ground glass.

The images of the sound waves are

or a small light projector may easily be constructed by the experimenter. The more powerful the source of light the better.

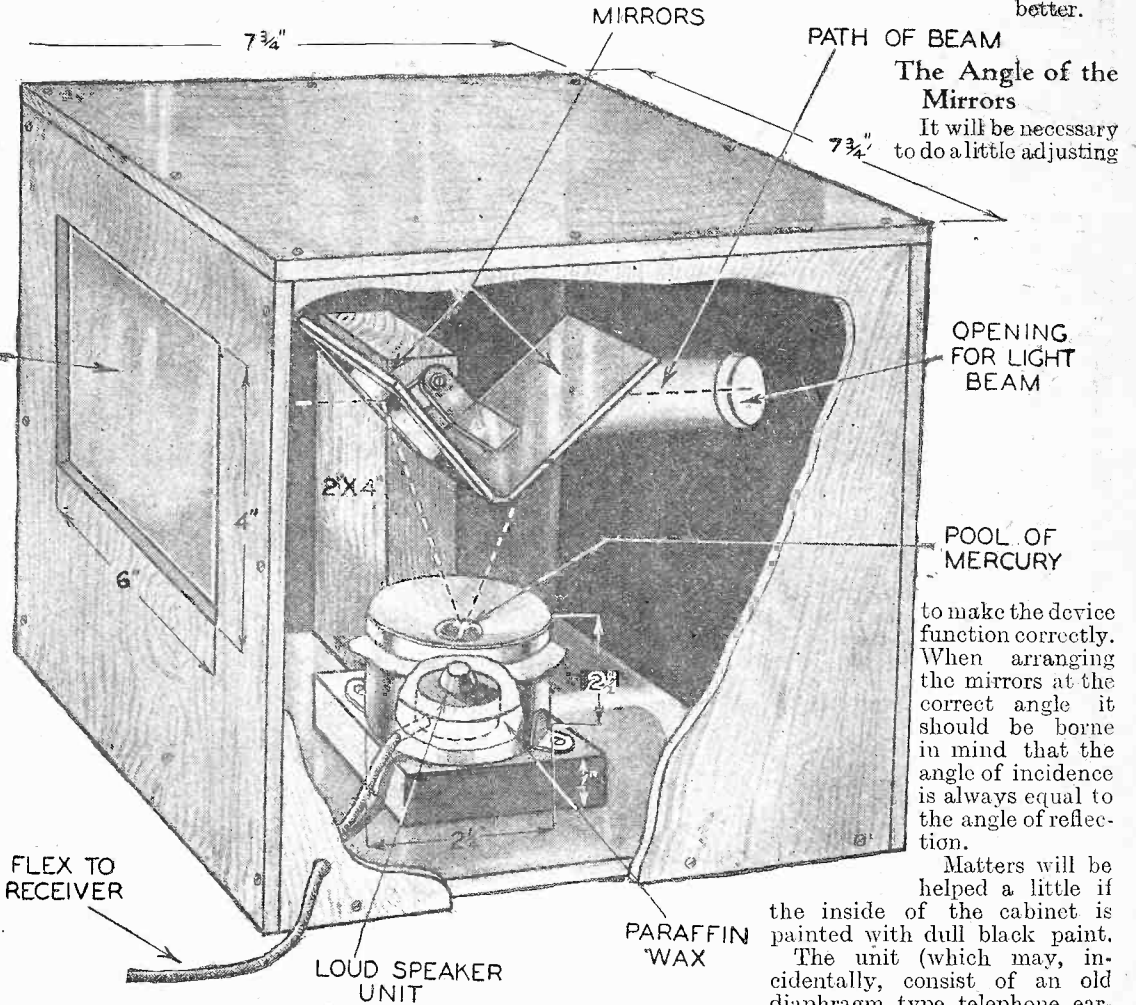

Fig. 1.—A cut-away view of the complete apparatus with all the necessary dimensions.

created by the light reflected by a series of mirrors, the mercury itself acting in the capacity of a mirror. These mirrors have tin backs of the size and shape illustrated, and are attached to the post with small angle brackets.

The beam of light may come from a small magic lantern,

the inside of the cabinet is painted with dull black paint. The unit (which may, incidentally, consist of an old diaphragm type telephone ear-

piece, should be connected to the output terminals of the receiver in the normal manner, when the Voxometer can be used

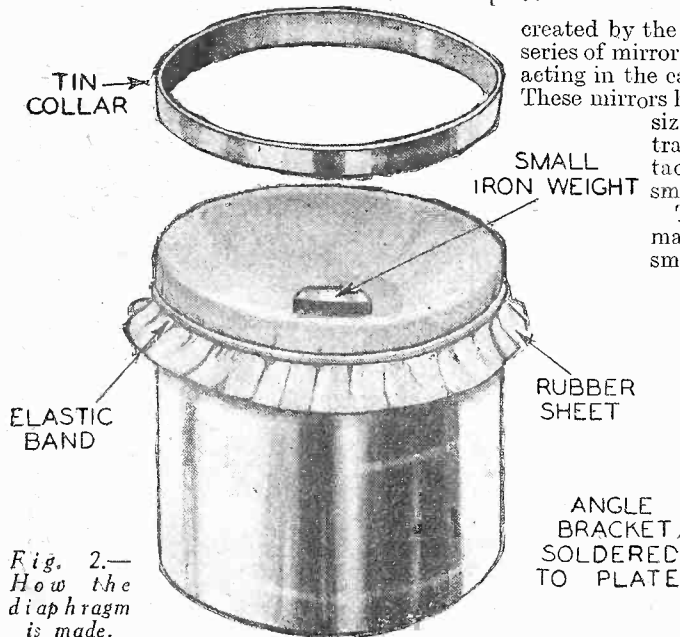

Fig. 2.—How the diaphragm is made.

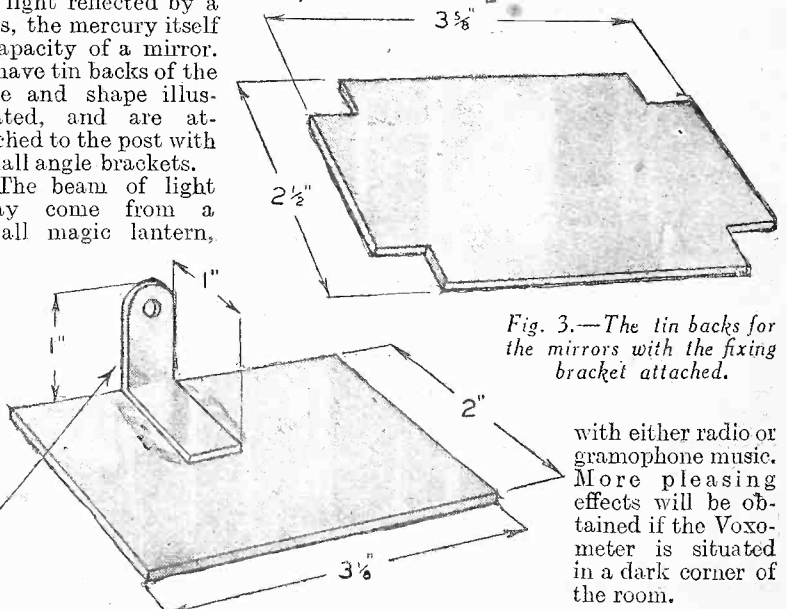
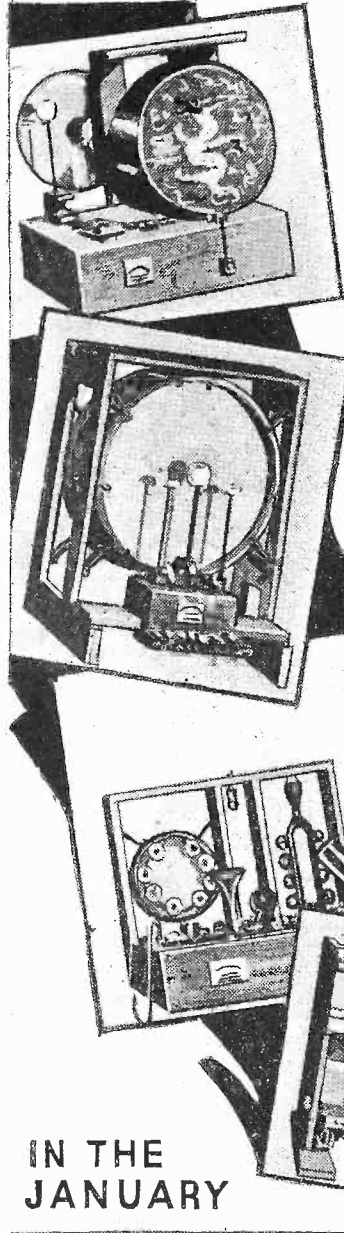

Fig. 3.—The tin backs for the mirrors with the fixing bracket attached.

with either radio or gramophone music. More pleasing effects will be obtained if the Voxometer is situated in a dark corner of the room.

MARVELS of the CINEMA ORGAN



YOU may often have wondered how the modern cinema organ is able to reproduce such a wide variety of instrumental effects—the drums, saxophones, violin, pipes, flute, and so on. This important article explains by means of valuable and hitherto unpublished diagrams, as well as lucid text, the principles of this modern adjunct to the talkies.

Other interesting features include: Guiding Aircraft by Wireless, How Maps are Made, Pearl Diving, Building a Model Petrol Engine, How to Bind Periodicals at Home, the Machine-gun Camera, a Garden Railway, etc.

IN THE JANUARY

PRACTICAL MECHANICS

ON SALE AT ALL NEWSAGENTS AND BOOKSTALLS,

6^d

or by post 7½d. from George Newnes, Ltd., 8-11, Southampton St., Strand, London, W.C.2.

Geo. Newnes, Ltd.

'PRACTICAL WIRELESS' THREE-VALVE SUPERHETS

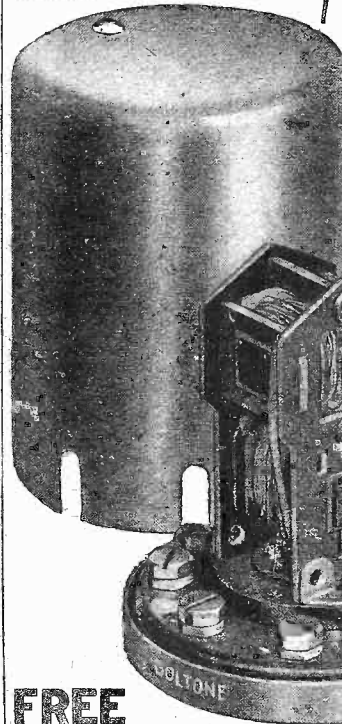

'GOLTONE' IRON-CORED COILS SPECIFIED BY DESIGNER

The outstanding technical merit of these "Goltone" Iron-Cored Coils has prompted the designer of the "Universal Three-Valve Superhet" to specially select them for use in this up-to-date receiver.

A high degree of selectivity, accuracy of matching and large voltage amplification are pre-eminent features.

R11 / 336 — 3-Coil Switch Chassis with G.I.C. 5, 6, and 7 Coils. Price . . . 36/6

Suitable for the range of 3-valve Superhets—Battery, A.C. and Universal versions. See December 15th issue, page 487 and December 22nd, for details and diagrams.

Full technical data and details of the six types available are given in a special folder. Free on request.

Circuit diagrams supplied with Single coils. "Goltone" Radio components are obtainable from first-class Radio Stores. Refuse substitutes—if any difficulty write direct.

FREE ON REQUEST 1935 60-page CATALOGUE, which includes details of many other suitable components for the "Universal Three-Valve Superhet."



PERFECTLY MATCHED for MATCHLESS TUNING

For a Happy New Radio Year employ

the COLPAK

The finest resolution you can make is to fit the finest tuning unit of all in your Set—the Colpak. The fact that it has been specified time and again by all the leading experts is ample proof of the Colpak's superiority.

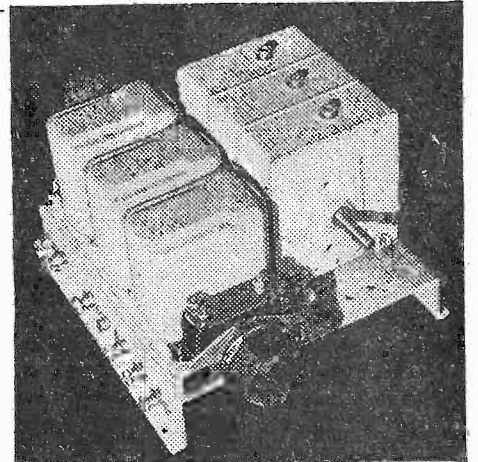

Made under licence from patentee, Hans Vogt.

COLVERN

Price complete 57/6 COLVERN LTD., ROMFORD, ESSEX.

FREE BLUEPRINTS OF SPLENDID SETS

To COLVERN, Ltd., Romford, Essex. Please send me full details and Blueprint of the **COLPAK CLASS B / A.C. MAINS SET***

*Strike out name of Blueprint not required. Stamps value 3d. to cover postage are enclosed.

NAME

ADDRESS

A6.....

If you would like a copy of our Ferrocart Booklet, please put a X here.....

VALVE TYPES AND USES-2

The Choice of a Detector Valve is Explained in Simple Language in this Second Article of the Series

It has been stated time after time that the detector valve is the most important in the whole receiver, since it is upon this valve that the duty of changing high-frequency signals into sound frequencies is imposed. The process of rectification is very involved and by no means well understood, but it is unnecessary in an article of this nature to give a complete explanation. The process can sufficiently well be explained by stating that the alternating voltages applied to the grid of the detector valve consist of a mixture of high-frequency impulses (corresponding to the carrier wave of the transmission) and low- or audio-frequency fluctuations which comprise the sound frequencies.

De-Modulation

These two sets of frequencies have to be combined at the transmitting station to enable the sound frequencies to be broadcast, and it is the object of the detector to separate the two sets of alternating voltages, passing those corresponding to the broadcast sounds to the L.F. amplifier and loud-speaker, and "discarding" the others. It is a fact that the terms detection and rectification are really misnomers as applied to the function being considered, and a far better name for the "detector" valve would be the "de-modulator" valve, since it "separates" the modulations from the carrier wave.

Most readers are doubtless aware that there are at least four different systems of detection (or de-modulation), the most popular of which is that known as leaky-grid. The other systems are known as power-grid, anode-bend, and diode. Anode-bend detection is, however, scarcely ever used to-day and, for most purposes, has no advantages over other systems; power-grid detection is popular for use in powerful sets in which there is a considerable amount of H.F. amplification; diode rectification calls for the use of a special valve, which will form the subject of a later article.

Three Main Characteristics

For the reasons set out above we need consider only leaky-grid and power-grid detection, and, as in the previous article, we may examine a series of valves which are suitable for use in one of these circuits. There are actually five Cossor battery valves which are suitable for use in the detector circuit, and the principal characteristics of these are set out in the panels on this page. Although all of the five valves detailed have 2-volt, .1-amp. filaments, it is evident from the specifications that they have otherwise widely differing characteristics. For example, the 210 R.C. valve has an impedance of 50,000 ohms and an amplification factor of 40, with a mutual conductance figure of .8 milliamps per volt; turning to the other end of the range, the 210 L.F. has corresponding figures of 10,000 ohms, 14, and 1.4 milliamps per volt.

The three characteristics just mentioned are those which are most important in making a choice of a valve for any particular circuit arrangement, so that we can consider all five valves in the light of these essentials.

TECHNICAL DATA COSSOR 210 R.C.

Filament Voltage	2
Filament Current (amps.)..	.1
Impedance (ohms)	50,000
Amplification Factor	40
Mutual Conductance8 m.a./v
Maximum Anode Voltage ..	150
Grid Bias for 150 Anode Volts	1.5 v.
Anode Current for 150 Anode Volts with 1.5 volt Grid Bias (average)85 m.a.
Normal Anode Working Voltage (approx.)	120

COSSOR 210 H.F.

Filament Voltage	2
Filament Current (amps.)..	.1
Impedance (ohms)	15,800
Amplification Factor	24
Mutual Conductance	1.5 m.a./v.
Maximum Anode Voltage..	150
Grid Bias for 150 Anode Volts	3 v.
Anode Current for 150 Anode Volts with 3 volts Grid Bias (average)	1.6 m.a.
Normal Anode Working Voltage (approx.)	50-120

COSSOR 210 H.L.

Filament Voltage	2
Filament Current (amps.)..	.1
Impedance (ohms)	22,000
Amplification Factor	24
Mutual Conductance	1.1 m.a./v.
Maximum Anode Voltage	150
Grid Bias for 150 Anode Volts	3 v.
Anode Current for 150 Anode Volts with 3 volts Grid Bias (average)	1.6 m.a.
Normal Working Anode Voltage (approx.)	50-120

COSSOR 210 L.F.

Filament Voltage	2
Filament Current (amps.)..	.1
Impedance (ohms)	10,000
Amplification Factor	14
Mutual Conductance	1.4 m.a./v.
Maximum Anode Voltage ..	150
Grid Bias for 150 Anode Volts	4½ v.
Anode Current for 150 Anode Volts with 4½ volts Grid Bias (average)	4.8 m.a.
Normal Anode Working Voltage (approx.)	100-120

COSSOR 210 DET.

Filament Voltage	2
Filament Current (amps.)..	.1
Impedance (ohms)	13,000
Amplification Factor	15
Mutual Conductance	1.15 m.a./v.
Maximum Anode Voltage..	150
Normal Anode Working Voltage (approx.):	
Grid Leak Rectification	50-90
Anode Bend Rectifica- tion	120-150

It was stated in the previous article, dealing with power valves, that in order to obtain

This illustration shows the electrode assembly of a modern battery valve.

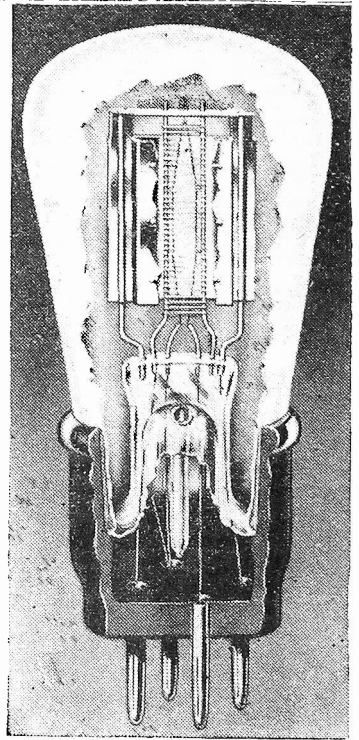

the maximum output from a valve the load, or impedance, connected in its anode circuit should be of some fairly critical value. In the case of power valves the optimum load is usually stated, but for other three-electrode valves whose impedance is greater than about 7,000 ohms such a figure is not generally given and the value of the load is not quite so critical. Nevertheless, the anode-circuit impedance is important and should not be less than twice the impedance of the valve. This means that the 210 R.C. valve, for instance, should have an anode load of 100,000 ohms or more, whilst the 210 L.F. requires a load of only 20,000 ohms.

Difficulties of High Impedance

To obtain an impedance of 100,000 ohms it is practically essential to employ a fixed resistance, since it is a very difficult and expensive matter to construct an L.F. transformer with a primary inductance sufficiently high to present so great an impedance. The use of such a high resistance presents another difficulty, though, because it causes a considerable drop in voltage; taking the average anode current with a voltage of 75 between the anode and filament as being .5 milliamp, the resistance causes a voltage drop of 50. This means that, in order to get 75 volts on the anode, a battery voltage of at least 150 (allowing 25 volts drop across the decoupling resistance) must be employed. Even with such a voltage available the actual amplification factor could not be expected to be more than about two-thirds of the maximum. Summing up, it can be stated that a valve such as the 210 R.C. is most suitable only in a receiver which has an ample supply of H.T. voltage, where the input voltage to the detector is low (not more than one preceding H.F. valve), and where resistance coupling is used between the detector and the following valve.

Turning again to the other end of the range, it will be seen that the 210 L.F. is best for use in a receiver having an appreciable amount of H.F. amplification and employing transformer coupling. This

Continued on page 568.



READERS' WRINKLES

THE HALF-GUINEA PAGE

Another Useful Switch

HERE is a type of aerial earthing switch which I have made and found very satisfactory. Most of the parts required can be found in the junk box. First scribe a circle from the centre of the ebonite and mark off the three spaces at the top and bottom of the circle to take the six studs which are sunk flush in the ebonite. Four more studs are required, which are fitted into the ends of the brass strips which are bolted to the small square piece of ebonite, a hole being drilled in the centre of this piece to take the spindle, which is locked each side with nuts, after which a knob can be screwed on. The hole in the centre of the base piece is drilled large enough to take the bush from an old variable condenser, which makes a good fit for the spindle; it is then pushed through, and a small spring put over the end and locked with double nuts. The switch is shown in the "on" position, the dotted lines indicating the "off" position, in which the set is completely isolated from the aerial and earth. The connections at back of the baseboard are made with strip copper or brass. Two stops are also fitted, as indicated in the drawing, so that the switch cannot go beyond the "on" and "off" position. Although there are six contact studs only five are used.—B. KNAPP (Newport, I.O.W.)

A Resistance Box

THE accompanying diagram explains fairly well how this useful gadget is made. It consists of three (or more) resistances fastened to sockets in a small piece of wood supported on battens. The connections on underside of base shown thus:

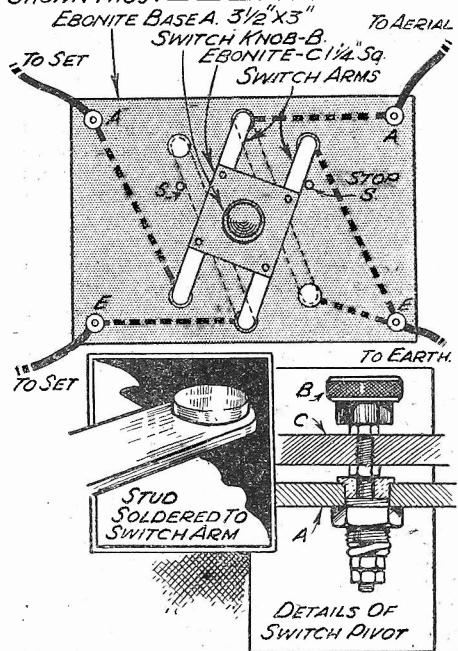

An efficient aerial-earthing switch.

THAT DODGE OF YOURS!

Every Reader of "PRACTICAL WIRELESS" must have originated some little dodge which would interest other readers. Why not pass it on to us? We pay £1-10-0 for the best wrinkle submitted, and for every other item published on this page we will pay half-a-guinea. Turn that idea of yours to account by sending it in to us addressed to the Editor, "PRACTICAL WIRELESS," George Newnes, Ltd., 8-11, Southampton Street, Strand, W.C.2. Put your name and address on every item. Please note that every notion sent in must be original. Mark envelopes "Radio Wrinkles." Do NOT enclose Queries with your Wrinkle.

sockets taken from a discarded H.T. battery serve very well. A maximum of six links, consisting of short lengths of flex with a plug at each end, serve to connect up the resistances in any one of fourteen ways, each giving a different value, as tabled below. Three resistances have been chosen for simplicity: four resistances can be connected to give no less than forty-eight different values. There are numerous applications for this resistance box in decoupling, shunting meters, R.C. couplings, etc. Suggested values of a, b, and c are: a=40,000Ω, b=10,000Ω, and c=20,000Ω.

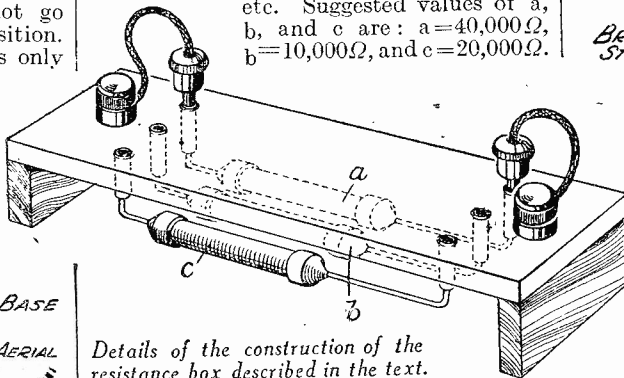

Details of the construction of the resistance box described in the text.

Con- nection.	Resist- ance in Ω.	Con- nection.	Resist- ance in Ω.
a b c	5,720	b+c	30,000
b c	6,670	a	40,000
a b	8,000	(b c)+a	46,670
b	10,000	a+b	50,000
a c	13,330	a+c	60,000
-c	20,000	a+b+c	70,000
(a c)+b.	23,330		
(a b)+c	28,000		

The vertical parallel lines in the above table signify in parallel, and the + sign indicates in series, e.g. (a||b)+c=a and b in parallel and c in series.—B. BURGESS (Sheffield).

A Pocket Station Log

TO make this handy log obtain an old watch and remove all the works, take off the glass, and paste a piece of paper inside, as shown in the sketch. Now take the empty case and drill two 3/16 in. holes at the right hand side, 3/16 in. apart. A short strip of brass is drilled with two holes to correspond. Two 2 1/2 in. wire nails are now taken and the heads reduced till they form an easy fit inside the case. Slip the piece

of brass on to the nails, push the points of nails through the holes at side of the case and fix the brass strip in position with a touch of solder; cut off the points of the nails and solder a terminal head to the end of each. A strip of paper is now taken and marked from 1 to 100, and ruled as shown.

PAPER STUCK INSIDE GLASS

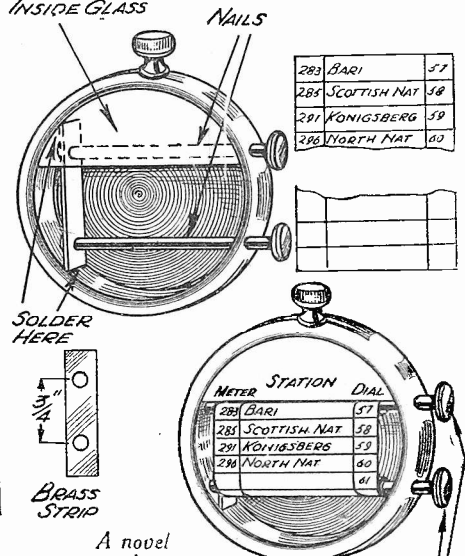

A novel pocket station log.

If the reader already has a station log he can now fill in the stations in their respective places, or they can be filled up later on.—ALEX. J. MASSON (Aberdeen).

An Aerial-Pulley Substitute

A GREAT drawback to the usual wheel pulley for an aerial is that the aerial wire is apt to come off the wheel and get wedged. A more efficient arrangement is to obtain a bent piece of steel tubing (a piece of old cycle handle-bar will do, and fix this to the mast, as shown in the sketch. The halliard can then be threaded through the tube and the aerial can then be pulled up or down without any fear of getting wedged, as in the case of a wheel pulley.—WALLACE HOOLE (Bearwood).

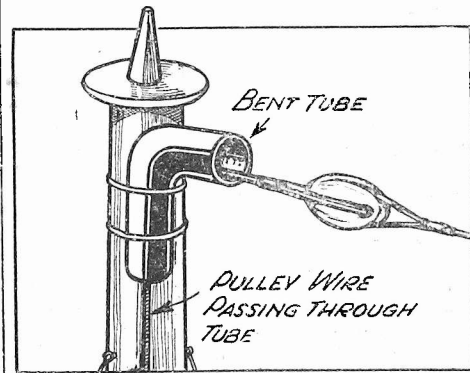

A handy substitute for an aerial pulley.

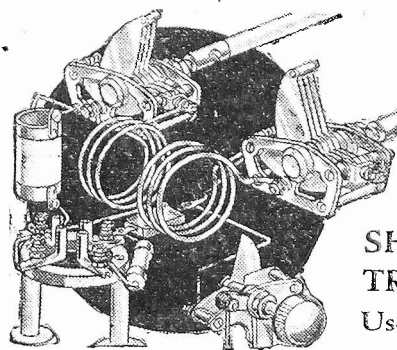

Short Wave Section

SHIPS, EXPEDITIONS AND DX TRANSMISSIONS By A. W. MANN

Useful Information for Beginners taking up Short-wave Work.

SHORT-WAVE broadcast transmitters nowadays operate on various wavelengths, using different call signs according to the time of day and night. Whilst searching for them the beginner will no doubt tune in transmissions of quite a different nature which are apt to leave him guessing.

Ships, expeditions, and experimental and commercial telephony transmissions are frequently heard working to schedule or otherwise, and a working knowledge of some of them will undoubtedly increase the beginner's interest and provide additional scope for his activities.

Ship-to-shore Stations

First I propose to comment upon ship-to-shore stations, and others which operate at intervals to no definite or published schedules.

The wavelengths assigned to ships and the shore stations with whom they work are as follows: 73.17 metres, 67.87 metres, 36.58 metres, 24.3 metres, 22.59 metres, 33.93 metres, and 16.85 metres. The chief interest in listening to ships is the tests which are carried out during which the position of the ship is sometimes given by the operator. Plot this position on your map, listen for her the following day and plot the new position, and then measure the distance between the two.

Searching around the wavelengths mentioned above you may hear a number of ships under various call signs. The following list will assist you to identify them:—

VQJP—"Queen of Bermuda."
VQJM—"Monarch of Bermuda."
GDLJ—"Homerie."
GFVV—"Majestic."
GMBJ—"Empress of Britain."
GMJQ—"Belgianland."
GBZW—"Berengaria."
GLSQ—"Olympic."

Amongst the Italian ships you may hear are:—

IBLI—"Conte De Savoia."
ICEJ—"Rex"; and the Germans.
DOAL—"Europa."
DOAH—"Bremen."
DOBX—"Columbus."
DHRL—"New York."

The following shore stations work with British, Italian and German ships:—

CGA-5—Drummondville, Canada, 61.15 metres.
GBC—Rugby, England, 60.26 metres.
CGA-3—Montreal, 22.58 metres.
GRC—Rugby, England, 23.47 metres.
DAF—Germany, 24.20 metres and 35.42 metres.

One of the pioneer shore stations in the ship 'phone service is WOO, which works with ships of various nationalities on the following wavelengths: 17.52 metres, 23.36 metres, 35.02 metres, 63.13 metres.

The official Italian shore station is located at Coltano, Tuscany, Italy, and may often

be heard calling the "Rex" and "Conte Rosa," using the call sign IAC on 16.89 metres, 35.80 metres, 45.10 metres.

German ships work regularly with their shore station DAF. The latter using wavelengths of 17.37 metres, 24.20 metres, 35.42 metres.

When listening to ships, make a note of the call signs heard, also the station they are working. A quick search over the assigned wavelengths often results in picking up the other transmission.

Another ship is the four-masted schooner "Seth Parker," behind which lays an interesting story. Phillip H. Lord, the American radio star, is the owner and is realising his boyhood ambition by sailing around the world.

The schooner is fitted with radiophone apparatus and has a coverage of 17.54 metres to 54.55 metres. Listen for the call sign KNRA on 14 metres, 17 metres, 24.30 metres, 25.36 metres, 23 metres, 19.63 metres, 48.70 metres, and 31.22 metres. KFZ, one of the Byrd Expedition stations, may be heard direct on these wavelengths also. The above is real DX and well worth tuning for, as the "Seth Parker" will be more or less constantly on the move. One kw is the power used.

Africa

A commercial telephone is operating at Cape Town S.C., using the call sign ZSB. The writer heard this station operating on 33 metres some time ago.

America

The beginner usually wishes to hear one or more American station. If you are able to listen during the afternoons, W3XAL, on 16.87 metres, between 3 p.m. and 4 p.m. daily, is worth trying for and almost sure to be received. The writer has listened to this station daily during November at R7-QSA5, also later in the evenings on the o-v-2 receiver. If you hear this station, make a note of the various items and address your reports to W3XAL, 30, Rockefeller Plaza, New York, N.Y., U.S.A. Enclose an International Postage Reply coupon with every report you send to stations abroad, and thus make sure of receiving verification. I do not propose to comment upon the better-known transmitters whose schedules are available, such as W8XK, W2XAD, etc.

W2XL is a most interesting American transmitter, and the most powerful, so far as reception over here is concerned, that the writer has ever heard with absolutely no fading.

W2XL does not appear to work to a definite schedule. If, however, you read in the daily press of a disaster to American aircraft, ship or the like, tune around 46.69 metres and you will probably hear W2XL contacting with various portable transmitters right on the spot.

Much confusion is caused by jumping to conclusions concerning the reception of various Rocky Point transmitters. Most lists show about a fraction of the transmitters located at this place. There are, it is reported, between seventy and eighty transmitters, and experimental transmissions are nearly always on the air using various wavelengths. WEB (43.29 metres), WET (31.68 metres), WQW (28.20 metres) are just a few heard to date. You may hear them working at intervals on position B. Position A is, of course, scrambled or inverted speech.

It is common nowadays for American broadcast short-wave stations, also commercials, to contact with Europeans and Asiatic stations during the early mornings from about 2.30 a.m. to 11 a.m., arranging relay schedules, so keep an ear open for such chance transmissions, which are often very interesting.

Japan

The Japanese language is rather difficult to recognise, and it is probable that amongst the stations you have logged as unidentified are a few of Japanese origin. The writer has received a number of Japanese transmissions during which announcements were made in English. One of them is JVH, 20.55 metres, which has been heard at 1.40 p.m. working with PHL, Holland. JVH is located at Kemikawoa Choo Chiba Ken, and it is possible to receive these transmissions at good headphone strength on an average two-valve receiver between 9.30 p.m. and 1.30 a.m.

Other Japanese stations are JVM (27.93 metres), between 6.30 a.m. and 12 noon, sometimes later; JVT (19.03 metres), JVE (19.15 metres), JVQ (40.16 metres), JVN (28.14 metres). There are, of course, a number of others working experimentally on various wavelengths.

Canada

The Canadian Marconi Company appear to have a number of experimental transmitters working, so do not be surprised to hear Montreal calling one of the Rugby group on position B. Station CGA3, on 23 metres, working GMBJ, "Empress of Britain," and other ships, is one of them, and may be heard during the afternoons. CGA, on 16.50 metres, is, of course, an old friend with a stentorian-voiced operator. Others, however, are springing up at intervals, and you should look out for—or, rather, listen for—CGA2 (21.83 metres), GGA4 (32.14 metres), and CGA7 (43.60 metres).

One of the Canadian S.W. broadcasters is VE9GW (49.22 metres), and is heard in this country after 11 p.m., according to reports. CJRO (48.85 metres) is another one. The transmissions of VE9DR are at present suspended.

Details and schedules of VK2ME and VK3ME appear in current lists. A new one, however, is VK3LR, located at Lyndhurst, and transmitting on 31.31 metres between 8 a.m. to 1 p.m.

In conclusion, do not overlook the 20, 40, and 75 metres amateur bands, as there is quite a lot of interesting telephony tests to be heard on these wavebands.

**A STANDARD WORK!
NEWNES ENCYCLOPEDIA
OF POPULAR MECHANICS**

By F. J. CAMM

5/- or 5/6 by post from

Geo. Newnes, Ltd., 8-11 Southampton Street,
Strand, London, W.C.2.



THE EASY ROAD TO RADIO. THE BEGINNER'S SUPPLEMENT

THE CORRECT USE OF ELIMINATORS

Many Users Fail to Obtain the Full Advantage of their Eliminators. This Article Stresses Many Points which Should be Watched.

OWNERS of battery-operated sets who live in houses wired for electric light can avoid all the troubles and much of the expense attaching to the use of high-tension batteries by employing a high-tension battery eliminator, or "mains unit." The price of a factory-made eliminator is, of course, greater than that of a high-tension battery—but the eliminator has years of life, while the battery must be renewed at fairly frequent intervals. If, however, first cost is an obstacle, it is a simple matter to make your own eliminator, and suitable designs are published in PRACTICAL WIRELESS from time to time.

device which differs from a high-tension battery in this respect, that whereas the battery is usually "tapped" at various points so that different lower voltages can be obtained for different valves, the diagrams show output terminals giving one H.T. voltage only. However, most commercial units are provided with some form of voltage divider which enables intermediate values to be obtained, and it is a simple matter when constructing one's own unit to provide either fixed or variable "tappings" by means of voltage-dropping resistances or potentiometers.

Proper Rating

Now for the question of how best to operate an eliminator. Of course, it is quite possible to connect it up in place of the original high-tension battery and let it go at that. Reception will certainly be satisfactory, and probably better than when the battery was used. But a little thought and arrangement will ensure infinitely better results.

In the first place, examine the number plate attached to your eliminator, or the description of the unit if it is made to a published circuit. Somewhere it will be stated what output the unit is rated to give. This will be so many milliamperes

at so many volts—for example, 25 milliamps at 150v. is a very common rating.

Despite this, if a greater current than 25 milliamps is drawn, the voltage will fall a little below 150 volts, and, conversely, if the full 25 milliamps are not drawn, the voltage will rise above 150 volts.

The next thing to do is to find out exactly what high-tension current your receiver takes when connected to 150 volts H.T. This information can be computed from the valve-maker's data, but as the exact figures depend very much upon the actual working conditions in the set, it will be better to measure the total high-tension drain with a

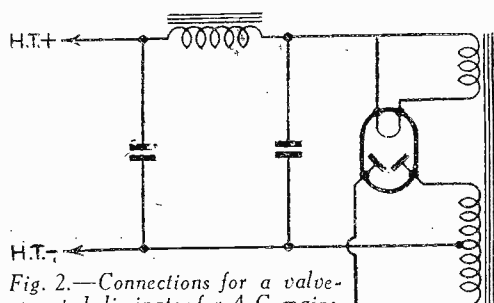

Fig. 2.—Connections for a valve-operated eliminator for A.C. mains.

Two Designs

For the benefit of newcomers to radio, it must be explained that there are two kinds of eliminator—one suitable for use on direct-current mains and the other for A.C. mains. The direct-current eliminator is the simpler and consists merely of what is called a "smoothing circuit," which is an arrangement of chokes and condensers, which removes the inequalities or "ripples" which exist in the mains voltage and thus renders the supply sufficiently steady for high-tension purposes.

If your district has alternating-current mains, however, the unit must be of the other type, which includes some form of "rectifier" for converting the alternating current to direct current before it is passed to the smoothing circuit. The rectifier may be either of the metal-oxide or valve type.

It is not intended to delve into the design of eliminators in this article, but to indicate the way in which the listener, having provided himself with a suitable unit, can utilise it to the best possible advantage. Before doing so, however, attention is drawn to the two diagrams given in Figs. 1 and 2, which show the internal connections of a D.C. and an A.C. mains unit respectively. It will be observed that these connections give a

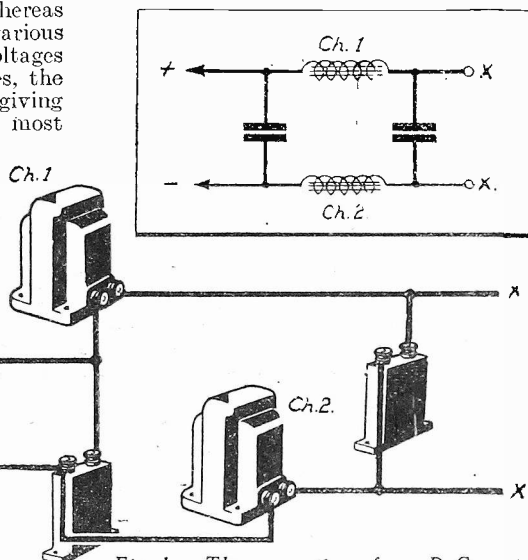

Fig. 1.—The connections for a D.C. mains unit. The choke in the negative lead is optional but often desirable, while the condensers may be 4 mfd. capacity but 8 mfd. electrolytic are better.

milliammeter, which should be connected in the common high-tension circuit, preferably between the H.T. — terminal of the set and the negative terminal of the high-tension supply. The method of taking this measurement is explained in the article in this issue entitled "Half-hour Experiments."

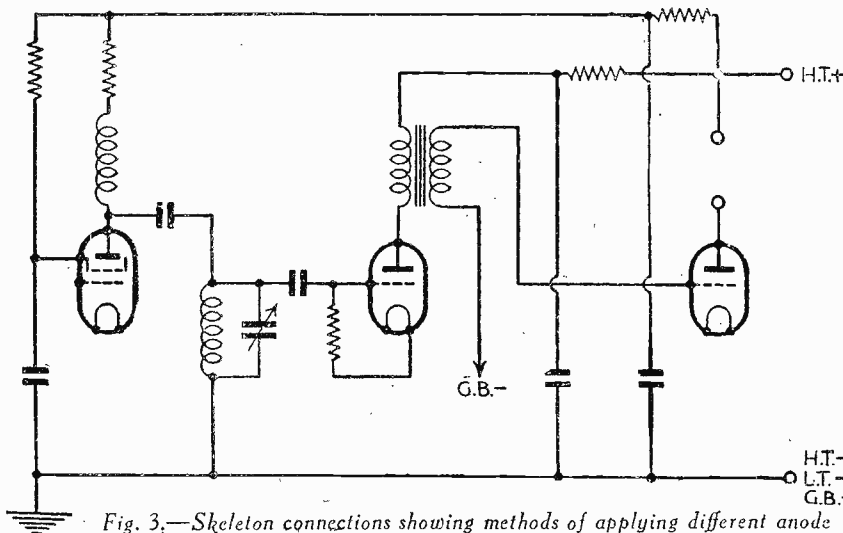

Fig. 3.—Skeleton connections showing methods of applying different anode voltages and decoupling circuits.

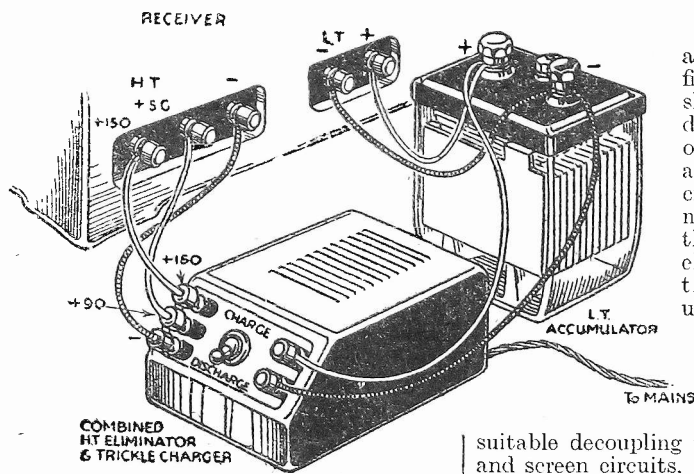

Fig. 5.—This illustration shows the simple connections for an H.T. eliminator of the type fitted with an L.T. trickle charger.

If, as is most likely, the total high-tension current of your set is well under the rated current of the eliminator, you can be sure of obtaining the full rated high-tension voltage and a little over. It is not likely that the voltage rise will be serious enough to harm the valves, for modern valves are always rated to operate on 150 volts at the anode, and the various components connected in the anode circuits of the valves always account for a certain voltage drop.

Using the Full Output

However, assuming that you have ample current to spare—say your set takes only 10 milliamps and your eliminator can go up to 25—it is worth considering whether you might not make use of the full rated output. One way of doing this, with excellent results in improved performance, is to substitute a good super-power output valve in place of the small power type fitted in so many sets.

The modern set with one or more high-frequency stages or their equivalent in intermediate-frequency amplification, is usually well able to load up a super-power valve, and a valve of this type is not generally fitted to sets merely because it requires approximately 10 to 15 milliamps of H.T. compared with the 5 or 6 taken by a smaller valve.

A Critical Voltage

The next stage in adjusting your set to work at maximum efficiency with a battery eliminator is to switch on the set and to take measurements of the high-tension voltage at the anode of each valve, and at the screens of each screen-grid or screened pentode valve. Provided the anode voltage in each case does not exceed 150 volts by more than a few volts, all will be well, except in the case of the detector valve. This has perhaps been running at 60 volts or even less, and the increased voltage obtained from the eliminator will have the result of rendering the reaction fierce if such a control is fitted. If an adjustable tapping is provided on your eliminator, this should be adjusted until reaction control is smooth. At the same time, it may be necessary to adjust screen voltages to the maker's recommended values, and lastly, grid-bias voltages to all valves should be checked up against the corresponding anode voltages, and adjusted if necessary.

As already stated, if a variable tapping is fitted to the unit, this should be used for the detector, which is the only valve in the average set requiring critical anode adjustment. But in view of the fact that an eliminator, and particularly an A.C. mains unit, has a rather higher resistance than a good high-tension battery, it is very important to provide

suitable decoupling in the various anode and screen circuits. It is for this reason that it is preferable to make an eliminator with only one H.T. positive terminal, and to supply the various valves with high-tension through separate voltage-dropping resistances, which also serve as decoupling

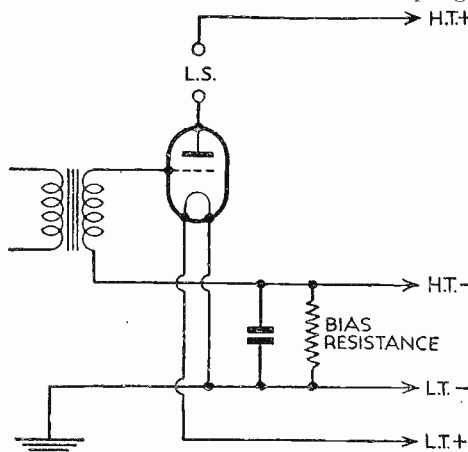

Fig. 4.—Applying automatic bias to a battery-operated output valve.

units. To do this, a suitable resistance must be connected in series with each circuit, and a condenser connected from the "valve" side of each resistance to earth, as shown in Fig. 3. The method of deciding what resistance to use is simplicity in itself. First determine what amount of voltage you want to "drop." For example, if your eliminator gives 150 volts and you want to run a certain valve at 120 volts, you require to drop 30 volts.

Multiply this by 1,000 and divide the number of milliamps taken by the circuit, and the answer is the required resistance in ohms. For example, to drop 30 volts in a circuit taking 2 milliamps would

require a resistance of 30, multiplied by 1,000 and divided by 2, which is, of course, 15,000 ohms.

A Final Point

As already mentioned, you will probably have a few volts to spare, so why not utilise them for automatic bias? The method is quite simple. Fig. 4 gives the connections for automatic bias to the output valve only, and it will be seen that all that is required is a fixed resistance connected between the negative terminal of the H.T. supply and the negative terminal of the L.T. terminal. A condenser of, say, 1 or 2 microfarads may be connected in parallel with the biasing resistance if required, but is not always necessary. The value of the bias resistance is calculated exactly as for a voltage-dropping resistance, except that in this case the current value to be used must be the total high-tension current for the receiver.

Subject to these adjustments, the set will really give of its best. Improvement will be due to several causes; the various valves being fed with their full high-tension voltage will give maximum amplification. The output valve will give its full rated output and distortion will be reduced. Moreover, performance will be consistently good, because there will not be the continuous deterioration of H.T. supply which always occurs with a battery.

A Standard Work
THE WIRELESS CONSTRUCTOR'S ENCYCLOPEDIA

3rd EDITION

By F. J. CAMM

(Editor of "Practical Wireless")

5'- net.

Wireless Terms and Definitions stated and explained in concise, clear language.

From all Booksellers, or by post 5/6 from Geo. Newnes Ltd., Southampton St., Strand, W.C.2.

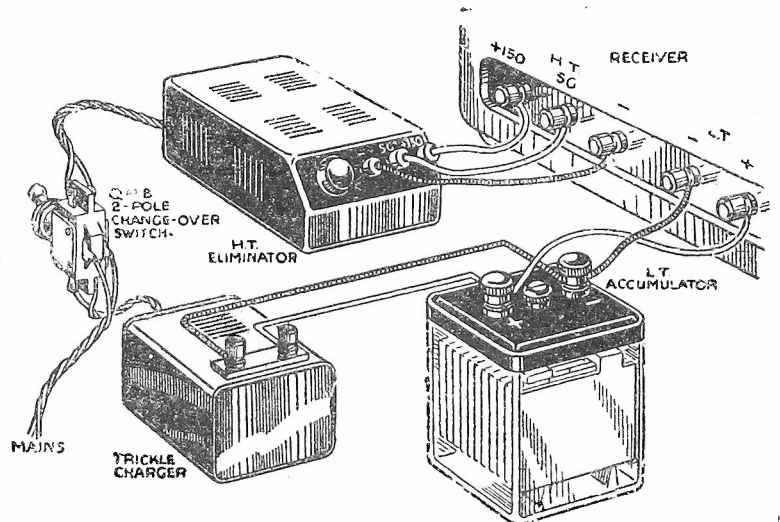

Fig. 6.—When a separate H.T. eliminator and trickle charger are employed the units should be wired up as shown above.

SUPPLEMENT TO "PRACTICAL WIRELESS"

AMATEUR TELEVISION

A CONTINENTAL SCANNING SUGGESTION

By H. J. BARTON CHAPPLE, B.Sc., A.M.I.E.E.

ARMED with the idea that ultimately the public will be initiated into the reception of television images possessing definition detail in excess of the present thirty-line B.B.C. service, many workers in the science have turned their attention to the development of methods which can give the increased number of scanning lines with reasonably straightforward adaptation of existing mechanical devices. Little success seems to have rewarded the efforts so far, but there is one idea emanating from the continent which appears to possess a germ of possibility.

The arrangement first came to light when an inventor wished to use sixty-line scanning with a mirror drum receiver, and yet avoid the necessarily large bulk and high cost of a sixty mirrored-drum because of its extremely accurate mirror positioning. It was therefore decided to use a ten-mirrored drum in conjunction with a system of six fixed mirrors, and the proposed method is shown in simple schematic form in Fig. 1. The optical analyser, as it is called, is stated to be capable of giving images of even higher definition, but this seems questionable at the moment.

First of all, the modulated beam of light from a crater-type neon lamp, or a commercial form of Kerr cell, is focused by one or more lenses on to the revolving drum with its individual mirrors set round the periphery at the correct angles one to the other. The ray or beam of light reflected from, say, mirror *a* is not thrown direct to the translucent viewing screen but meets the first mirror of a series of six fixed ones as indicated.

light beam from the modulated source, it performs an identical operation to mirror *a* and a further six lines are scanned on the screen. At the end of one revolution of the ten-mirrored drum, sixty lines have been traced, and the process then repeats itself again, continuing this at a rate depending entirely on the speed with which the drum is revolved by its coupled motor.

Objections

One very prime difficulty which seems to

ROTATING MIRROR DRUM

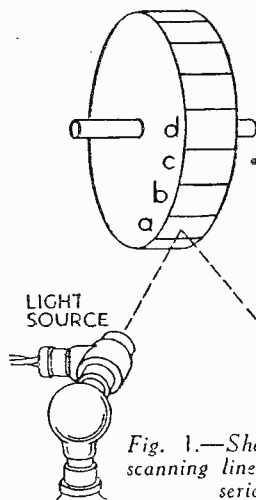

SCREEN

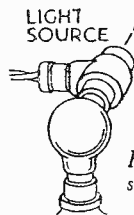
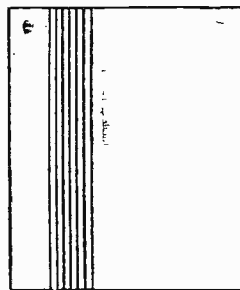

FIXED MIRRORS

Fig. 1.—Showing how the number of scanning lines can be increased with a series of fixed mirrors.

suggest itself is that the ultimate picture ratio of the received image traced out in this way is very prone to be quite different from that which is intended. Then, again, the optical focusing is more complicated, due to the additional mirrors required, while the fact that additional light reflections are introduced in the receiving ap-

paratus entails a loss of light which is sure to affect seriously the brilliance of the received image.

Although the work and cost of making the mirrored drum is simplified, there is the extra complication of the set of six fixed mirrors, the individual setting of which is not an easy matter. Finally, if the optical path of any one of the double reflected rays is traced out it will be found that if it is in focus at the centre of its path across the screen, it will be very much out of focus at the extremities. The result of this is the production of a scanning field which is misshapen, and certainly not rectangular, as should be the case if undistorted images are to be secured.

The idea, however, is not one which can be wholly discarded, and it is conceivable that mirrors with reflecting surfaces of definite curvature may in some measure assist in overcoming some of the objections which have been cited.

ANOTHER MOTOR SPEED CORRECTING DEVICE

AN absence or a reduction of "hunting" or "floating" in the received television image is the aim of all television enthusiasts, and in the columns of this journal many ideas have been put forward to render assistance in this connection. The number which have been tried from time to time, however, is in no way exhausted, and the arrangement shown in Fig. 2 is yet another suggestion which might appeal to those who care to experiment with their apparatus. Many automatic devices which depend on the utilisation of the synchronising signal, which is included in the radiated television image signal, function in rather an erratic manner when beyond the normal service range of the London National transmitter. This is because of the signal fading, and even when some form of automatic volume control is included in the radio set, at least in so far as the modulation fed to the synchronising device is concerned, continual re-framing and re-phasing becomes necessary.

With the present B.B.C. transmissions, new mains installation arrangements have been made to ensure constancy of speed with the scanning mirror drum, and it is therefore necessary to devise some means whereby fluctuations which occur in the mains feeding the receiver motor are compensated.

Method of Operation

During the course of the travel of the drum mirror *a* the beam moves across this first fixed mirror and so describes a horizontal or vertical (depending upon whether the transmitter exploration analysis is carried out horizontally or vertically) line on an adjacent screen from the ray reflected from this mirror.

With the modulated beam still impinging on mirror *a* the ray next meets the second mirror, which is inclined slightly with reference to the first mirror, and hence brings about a small re-alignment of the beam so as to describe a second scanning line adjacent to the first. This light beam traversal is so arranged that it impinges on each of the separately inclined six mirrors during the whole of the time that the modulated ray is in "contact" with mirror *a* on the drum. Thus for the partial revolution of a ten-mirrored drum (actually an angular rotation of 36 degrees) six separate and distinct scanning lines, side by side, have been described on the translucent screen.

When mirror *b* now takes charge of the

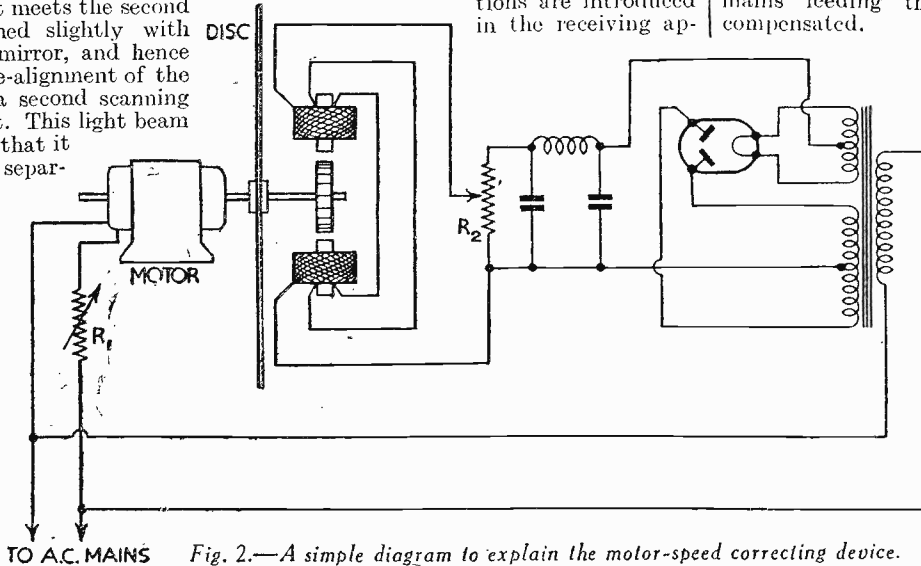

Fig. 2.—A simple diagram to explain the motor-speed correcting device.

The Device Explained

Reverting to Fig. 2, an ordinary scanning disc is shown, this being driven by a universal type motor, which can be supplied from the A.C. mains, and be speed controlled with the aid of a variable resistance R_1 . If preferred, this resistance can be made up from a coarse and fine resistance control, but that is a detail which the constructor can settle for himself. On the motor shaft that is integral with

(Continued overleaf)

GOVT. Surplus TELESCOPES

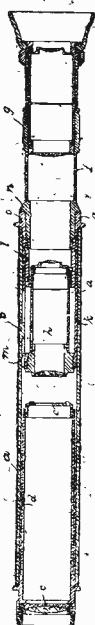

High-grade Instruments to rigid Admiralty Specification. Cost £25 each. Telescopes were for long-range naval and army guns. Focus draw-outs avoided by internal adjustment operated by milled band *g* on rapid thread screw. A fitting is provided for the use of a pea lamp for night sighting. Telescopes are slightly soiled but otherwise perfect, and each is in hardwood carrying case. They are a **WONDERFUL BARGAIN** at 17/6.

Best Value Ever Offered in MICROPHONES. 5,000 new Western Electric type Transmitters, speech and sound, etc., complete and perfect, 1/- each. Microphone Transformers, 3s, 6d. each.

HOME RADIO MIKES
5/6 and 15/- Illustrated List Free.

EDISON STEEL CELLS. We have some of these high capacity discharge cells cheap up to 400 a.h.

COIL TURN COUNTERS, for checking the number of turns up to 9,999 on dial. Soiled only, 1/3 each.



METERS. We carry large stocks of Meters, all ranges. Special Charging CZ 3-0-3 amps. 5/-. Pole Testers, 2/6, 0-20 volts, 5/-, 0-50 volts, 5/-, 0-100 volts, 5/6, 0-200 volts, 6/-; all A.C. or D.C.

MOTORS. Special line of A.C. fractional H.P., 100 volt, 15/-; 220 volt, 17/6. Large stock of all sizes for Cine work. State volts and supply.

Lesdix Microphones



reproduce your voice amplified from your radio set to loud speaker.

MICROPHONE BUTTONS for all purposes. As supplied to G.P.O. Our price has always been 1/-. We have supplied thousands. Leadlet free.

SEND FOR JANUARY BARGAIN LIST "N."

ELECTRADIX RADIOS,
218, UPPER THAMES ST., LONDON, E.C.4

FREE ENGINEERS

HERE'S YOUR OPPORTUNITY AND OUR GUARANTEE!

We are prepared to coach you for recognised Examinations such as A.M.I.Mech. E., A.M.I.E.E., A.M.I.A.E., G.P.O., etc., under our definite Guarantee of "NO PASS—NO FEE." This is your opportunity to get out of the "hammer and file brigade" and to commence earning real money. Full particulars will be found in the 1935 edition of "ENGINEERING OPPORTUNITIES." This book gives details of all Engineering Examinations and outlines Home-Study Courses in all branches of Civil, Mech., Elec., Motor, Aero, and Radio Engineering, Building, etc. Send for your copy of the book to-day—FREE.

BRITISH INSTITUTE OF ENGINEERING TECHNOLOGY,
399, SHAKESPEARE HOUSE, 29/31, OXFORD ST., LONDON
South African enquiries: P.O. Box 4701 Johannesburg.
Australasian enquiries: P.O. Box 3391 Sydney.

Add 50/- WEEKLY to your earnings

by charging accumulators in your spare time.
Complete plant for A.C. mains incorporating Westinghouse Rectifiers to charge 105 L.P. cells weekly. Trade price £4 4s. or 8/- monthly. Send for descriptive Booklet.

M.P.R. Ltd ROMFORD, ESSEX.

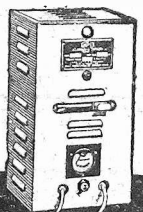

ANOTHER MOTOR SPEED CORRECTING DEVICE

(Continued from previous page)

the disc drive is mounted a toothed wheel or rotor which can really have any even number of teeth from six upwards. On trial, eight has been found quite a satisfactory number.

This wheel rotates between a pair of magnets mounted diametrically opposite to one another. The windings of these electro magnets are fed from an eliminator, which derives its A.C. feed from the same mains to which the motor is connected. The eliminator is quite standard in character, the rectifying valve being of the D.W.2 type, rated to give 60 milliamps at 250 volts. Across the smoothed rectifier feed is a high resistance potentiometer R_2 , capable of carrying the full load current without overheating, and across one end of the potentiometer and the variable tap is joined the pair of magnets, the coil windings of these magnets being connected in series to give north and south polarity. See that the air gap between the rotor teeth and pole piece facets is the minimum possible, while the wheel itself can be quite small, say 2ins. in diameter and 1/4in. thick. If the field coils are home made, then a satisfactory number of turns for each will be 5,000, using No. 37 S.W.G. enamelled wire.

A Simple Action

To operate this device, the motor speed should be adjusted by means of the resistance R_1 , so that it is slightly above the correct value of 750 revolutions per minute. Then alter the potentiometer R_2 when actually observing images on the television receiver so that there is just sufficient current passing through the electro magnets to produce a magnetic braking action on the toothed rotor to reduce the motor speed to the correct value.

If, now, a fluctuation in the mains voltage brings about a slight reduction in voltage, the motor speed will tend to drop. The extent of the magnetic braking action reduces at the same time, however, owing to the rectifier feed falling, and the two effects will counter-balance when the adjustments have been made correctly. Similarly, if the voltage of the mains rises, then the tendency for motor speed to increase will be nullified by the increased magnetic braking action. A few trials will no doubt have to be made to ascertain just the right balance of settings between R_1 and R_2 , but once this has been settled the device will function satisfactorily provided the transmitter motor maintains a correct speed.

BOOK REVIEWED

Radio Year Book for 1935

SO attractively is the subject-matter presented that one might be the veriest novice in the realm of radio and yet be fascinated by the 188 pages of the Radio Year Book for 1935.

The brief introductory chapter traces the history of the B.B.C. from its formation to its present position—enlightened to no small degree by the very omnipotence of the B.B.C. itself. There follow numerous chapters which include "A Day at Broadcasting House," "Television: its Present and Future," and "B.B.C. Artistes on the Ether." An up-to-the-minute wavelength chart is also set out within its pages, as are also a vast number of varied items of interest to the listener. It is published by George Newnes, Ltd., and is on sale everywhere at the modest price of one shilling.

VALVE TYPES

(Continued from page 562)

valve is also very suitable when power-grid detection is employed, since a comparatively high voltage can be applied to its anode without the use of a battery of unduly high voltage, and its grid-voltage handling capacity is high.

Between the two extremes just considered there are three other valves: the 210 H.L., 210 Det., and 210 H.F. The first of these is similar in many ways to the R.C. type, but its impedance is not high. It can be used with either R.C.C. or transformer coupling, but the transformer must be a good one having a high primary inductance. This valve is very suitable for use as detector in a set not provided with an H.F. stage and when the greatest possible degree of efficiency is required.

The H.F. valve has a still lower impedance and can therefore be used quite satisfactorily with L.F. transformer coupling. It may well follow a single-stage high-frequency amplifier, since it will not overload very readily and gives a useful degree of amplification. Perhaps it should be mentioned at this point that although it is not usual to consider a detector valve from the point of view of amplification factor it is important that this characteristic should be taken into consideration. The reason for this is that, in nearly every instance, the detector performs the double duties of de-modulation and H.F. amplification. This is because the use of reaction causes a certain amount of the H.F. currents appearing in the anode circuit of the valve to be passed back to the grid circuit.

The "Special" Detector

There remains one more valve in the series to consider—this is the 210 Det. As the name implies, this valve has been specially developed as what might be called a "super" detector. Its characteristics are such that extremely smooth reaction control is possible and, although the amplification factor is not very high, a fairly high stage gain can be obtained, due to the fact that a transformer of fairly high ratio (up to about 1:6) can satisfactorily be employed. The 210 Det. will handle satisfactorily a fairly large grid input, and may therefore be used after one or two efficient H.F. stages without there being any danger of overloading. It is also suitable for use as second detector in a superheterodyne which has not more than one intermediate-frequency amplifying stage; when there are two or more such stages, it is generally better to use the 210 L.F., which should, for preference, be connected on the power-grid principle.

Power-Grid

Before concluding this second article of the series it might be well to write a few notes concerning power-grid detection, concerning which a certain amount of misunderstanding frequently exists. It will be fairly evident from what has been written above that power-grid does not give increased amplification, and therefore cannot be productive of greater volume unless a correspondingly increased signal voltage is applied to its grid. As regards the connections for power-grid, it is generally known that these are the same as for leaky-grid, but that the values of the grid condenser and leak are lower (.0001 mfd. and .25 megohm are the usual ones). But a point that is often overlooked is that the high-tension voltage applied to the anode of the valve must be a good deal higher than normal; a minimum voltage of 100 is necessary.

THE AMPLION RADIOLUX SUPERHET

A Five-Valve All-Electric Superhet Table Model

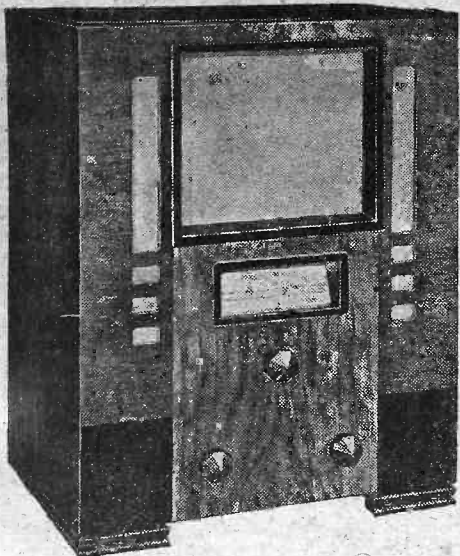

A three-quarter front view of the Amplion receiver, showing the simple knob layout and the attractive appearance of the cabinet.

ONE of many interesting features of the Amplion A.C. Radiolux Superhet Receiver is the neon tuning device fitted above the tuning scale. This indicates faithfully when a station is correctly tuned in, by the fact that the length of the glow in the neon lamp is then fully extended. The set incorporates every modern device, the latest valves, knife-edge selectivity, and a minimum number of controls. A comprehensive specification is included in the panel printed on this page. Definitely an ideal set for even the most exacting wireless enthusiast, it is nevertheless very moderately priced.

The wave-change switch knob is situated on the right-hand side of the receiver, and the wave bands covered are from 200 to 550 metres on the "medium" waves, and from 900 to 2,000 metres on the "long" waves. The on-off switch and the volume control are operated by a knob on the left-hand side of the set. The set having previously been connected to the mains, is switched on by slightly turning the knob just referred to in a clockwise direction, thirty seconds after which, the set in the meantime having become sensitive, further

movement of the knob controls the volume.

The Circuit

The circuit is of an entirely new design comprising eight tuned stages. The new H.F. pentode is coupled to an octode frequency-changer, which is, in turn, I.F. transformer coupled to the second H.F. pentode detector, this being R.C. coupled to the pentode output stage. The H.F. variable-mu pentode controls signals of all strengths without the slightest trace of distortion, and makes the receiver par-

ticularly suitable for use in districts surrounding high-power stations, such as Droitwich. The latest type of octode frequency-changer has been employed in the second stage, being coupled to the second detector by a high-efficiency I.F. transformer. The second detector circuit

The Set Tested

which has been usually found difficult to balance has been specially designed, and the unique method employed ensures a pure signal being delivered to the output stage. A recent development in pentode-valve design is incorporated in the output stage and allows for an undistorted output of three watts. Volume control is effected by controlling the first stage gain by use of a potentiometer which incorporates the mains on-off switch.

Constructional Details

On test, a considerable number of stations was heard on both long and medium waves at good loud-speaker strength. Selectivity was exceedingly high, and second-channel whistles were entirely absent. On rotating the tuning knob it was found that background noises were very loud between stations, thus showing the high amplification of which the set is capable, but immediately a signal was tuned in the background disappeared, leaving the signals clear and interference-free.

The set is enclosed in a well-made walnut cabinet of the conventional table type which has been designed to prevent "boom" and box-resonance. The Amplion speaker is fitted above the receiver. The intermediate transformer is fitted with a small pre-set condenser, to enable it to be carefully tuned to give optimum load and thus obtain maximum efficiency. An aerial trimming knob is situated at the rear of the receiver chassis, and is used for accurate adjustment of the aerial in use. The set is fitted with pick-up terminals and provision is made for connecting an extra loud-speaker. The internal speaker may be easily disconnected if so desired, thus enabling the speakers to be worked separately.

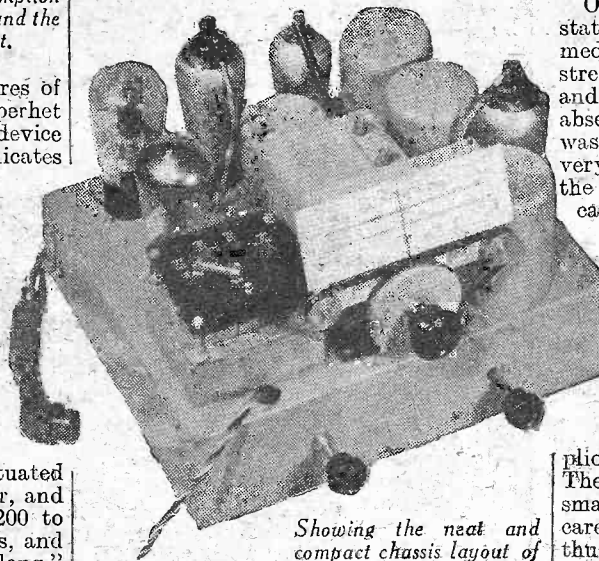

Showing the neat and compact chassis layout of the Amplion superhet.

ticularly suitable for use in districts surrounding high-power stations, such as Droitwich. The latest type of octode frequency-changer has been employed in the second stage, being coupled to the second detector by a high-efficiency I.F. transformer. The second detector circuit

SPECIFICATION IN BRIEF

RECEIVER: Amplion Radiolux 5-valve superhet. A.C. table model.

MAKERS: Amplion (1932) Ltd.

SPECIFICATION: Five valves. Variable-mu high frequency pentode, octode frequency changer, intermediate amplifier, high frequency pentode detector, with power pentode output, and an indirectly heated full-wave rectifying valve. Energised moving coil speaker. Automatic volume control. Cellulosed steel chassis. Illuminated full vision scale. Neon light visual tuning. Attractive walnut cabinet, 19 x 15 x 12-in deep.

PRICE: 12 guineas. A.C. mains 110 or 190/265 volts, 40/100 cycles.

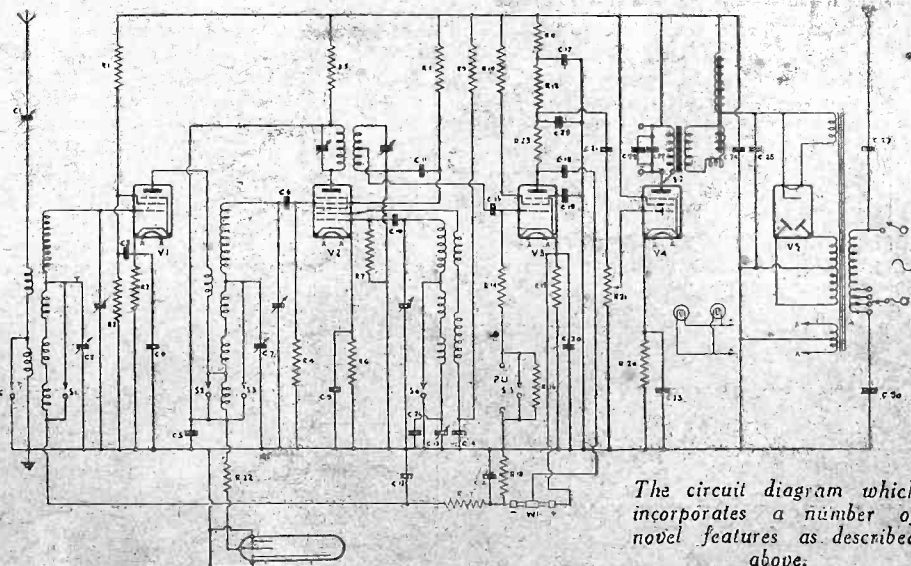

The circuit diagram which incorporates a number of novel features as described above.

Let Us Send You This 28-Page Booklet—Free



It gives all particulars of various Courses that cover every phase of Radio work. The Radio industry is progressing with amazing rapidity. Only by knowing thoroughly the basic principles can pace be kept with it. I.C.S. Instruction includes American broadcasting as well as British wireless practice. It is a modern education, covering every department of the industry.

OUR COURSES

Included in the I.C.S. range are Courses dealing with the Installing of radio sets and, in particular, with their Servicing, which to-day intimately concerns every wireless dealer and his employees. The Operating Course is vital to mastery of operating and transmitting.

There is also a Course for the Wireless Salesman. This, in addition to inculcating the art of salesmanship, provides that knowledge which enables the salesman to hold his own with the most technical of his customers.

Then there are the Preparatory Courses for the City and Guilds and I.W.T. Exams.

We will be pleased to send you details and free advice on any or all of these subjects. Just fill in, and post the coupon, or write in any other way.

International Correspondence Schools, Ltd.,
Dept. 94, International Buildings,
Kingsway, London, W.C.2.

Without cost, or obligation, please send me your "Radio" booklet of information about the Courses I have marked X

- COMPLETE RADIO
- RADIO SERVICING
- RADIO EQUIPMENT
- RADIO SERVICING AND SALESMANSHIP
- WIRELESS ENGINEERING
- WIRELESS OPERATORS
- EXAMINATION (state which)

Name..... Age.....

Address

IMPRESSIONS ON THE WAX

REVIEWS of the LATEST RECORDS
By T. ONEARM

TWO brilliant little novelties from the Orchestre Raymonde appear in the Columbia list this month. "Glow Worm" is familiar to most, and here it is the lighthearted treatment and innumerable instrumental touches that stamp it as a refreshingly different interpretation. "Indian Mail" is an impression of an Indian mail train, and here again the orchestra excels in instrumental effects, the bustle of Oriental life mingling with the sounds associated with the great roaring locomotive being cleverly done. This record is *Columbia DB1467*, and you should certainly hear this disc.

Turner Layton (of Layton and Johnstone) is one of the most accomplished artists in variety. As pianist and baritone in the famous duo he is, of course, well known, but he is equally at home singing in several languages, notably French. He sings in this language on *Columbia DB1470* "There's No More You Can Say" (Parle moi d'autre chose). On the other side of this disc he sings the new big hit song composed by Jerome Kern, "Smoke Gets In Your Eyes."

Malcolm McEachern, who is known more widely as "Mr. Jetsam," of Flotsam and Jetsam fame, sings two fine songs this month on *Columbia DB1465*. They are the "Cobbler's Song" from "Chu Chin Chow," and Mendelssohn's "I'm a Roamer." In the first we have the well-known philosophic song of the cobbler who estimates the world by its tread, while the other is a very difficult song to render. These titles constitute a fresh triumph for the redoubtable "Mr. Jetsam." I can specially recommend this record to readers.

Regal Zonophone Records

An exceptionally fine record appears in the above Company's list for this month, on which readers will have the pleasure of hearing twenty-four selections from this Company's star records of 1934. The artists appearing on this record, which is *Regal MR1512*, include: The Commodore Orchestra; Singing Mountaineers; Billy Cotton and his Band; Robert Rolo; Totem Lodge Orchestra; Joe Loss and his Band; Hill Billies; Cavan O'Connor; Scott Wood and his Orchestra; Shaw's Hawaiians; Humber and his Orchestra; Anona Winn; and the Broadway Bandits. This fine array of artists introduce such popular tunes as: "In Town To-night," "Home on the Range," "Play to Me, Gipsy," "Dreamy Serenade," "Over My Shoulder," "Wagon Wheels," "Little Man, You've Had a Busy Day," "Nasty Man," "Isle of Capri," "Love in Bloom," "Ole Faithful," "My Song for You," "Carioca," "Little Valley in the Mountains," "Oh! Muki, Muki Oh!" "Swaller Tail Coat," "Love Thy Neighbour," "Mama Don't Want No Peas, No Rice," "The Very Thought of You," "On a Steamer Coming Over," "Over on the Sunny Side," "Keep Young and Beautiful," "Did You Ever See a Dream Walking?" and "My Song For You." Hear this record without fail.

FULL of INTEREST



Fully illustrated with constructional details for building: Battery and Mains S.W. Receivers—6v. S.W. Super-het with A.V.C.—All-Wave Wavemeter—5-metre Receiver—Simple 5-metre Transmitter—Crossfeeder Aerial System—Battery and Mains S.W. Converters—Amateur Bands Receiver—100 watt Transmitter—Eliminators, etc. COMPILED BY THE LEADING SHORT WAVE SPECIALISTS. Obtainable from your radio dealer, W. H. Smith, or in case of difficulty, direct from STRATTON & CO., LTD. (Dept. 21), Bromsgrove Street, Birmingham. London Service Depot—Webb's Radio, 14, Soho St., Oxford St., W.1. Glasgow Service: J. R. Hunter, 138, West Nile St. PRICE 1/6

1935 EDDYSTONE SHORT WAVE MANUAL



FITS ANY BATTERY SOCKET

No need to close the prongs with pliers, no need to open them with a penknife.

Clix are the only "Master" plugs which are non-collapsible and make perfect and permanent contact with any battery socket. No amount of vibration will move Clix plugs. Change over to Clix now and forget faulty contacts.

Clix "Master" Plugs for H.T. and C.B. are supplied in Red and Black engraved, or 8 assorted colours. 1 1/2d. each.



There is a "Master Plug" available for every radio and electrical purpose.

LECTRO LINX LTD.,
79a, Rochester Row, London, S.W.1.

PRACTICAL TELEVISION

6d. EVERY MONTH

Published by GEO. NEWNES, Ltd.,
8-11, Southampton Street, Strand, W.C.2.

CATALOGUES RECEIVED

To save readers trouble, we undertake to send on catalogue of any of our advertisers. Merely state, on a postcard, the names of the firms from whom you require catalogues, and address it to: "Catalogues," PRACTICAL WIRELESS, Geo. Newman, Ltd., 8-11, Southampton St., Strand, London, W.C.2. Where advertisers make a charge, or require postage, this should be enclosed with applications for catalogues. No other correspondence whatsoever should be enclosed.

EDDYSTONE SUPREMACY

"PROOF of Eddystone Supremacy" is the title of an interesting collection of testimonials—interesting not only because of the variety of features most praised, but also because of the world-wide sources from which the various letters sprang, showing that however far afield a man may roam he may still enjoy efficient radio. "My wife and I," says one writer, "owe you the biggest thrill dwellers in these remote wilds can experience—the boom of Big Ben!" A glance down the list of place-names would disturb even the most complacent Fellow of the Royal Geographical Society. Check by jowl with Masid-i-Suleiman we find Jubbulpore; Umboghtwini looks haughtily across at Lome; yet nowhere do we detect a dissenting note in that chorus of praise—praise that would strike conviction in the heart of the solitary Esquimaux, whose country is apparently the only one not so far represented!

"SUNBEAM RADIO"

AN attractive two-colour leaflet just to hand gives specification details and illustrates, attractively, the new Sunbeam receiver, type "57." Described as a luxury radio at moderate cost, it has been designed primarily to give perfect reproduction. Some idea of its standard of luxury may be judged from a brief consideration of its specification. This eight-stage, five-valve, universal-mains, all-electric, superheterodyne receiver has band-pass input, and 9 Kc. selectivity. Mullard valves are standard. Other features are as follows: Octode detector-oscillator, H.F. pentode intermediate-frequency amplifier, double-diode detector. The first I.F. stage is reflexed from the I.F. valve. Suitable for 200 to 250 volts A.C., 40 to 100 cycles, or for D.C., this receiver has full automatic volume control, and an undistorted output of 2½ watts.

SUPPRESSING INTERFERENCE

THE Research Department of Belling and Lee, Ltd., have obviously devoted much care and preparation in the production of their sixpenny illustrated booklet entitled "Cutting the Crackle out of Radio," now in its fourth edition. Briefly, it is a description of the methods evolved by the Post Office and by engineers throughout the world for the tracing and suppression of electrical interference with broadcast reception, and includes the results of research work by the firm in question. The subject is developed from first principles, as the title of the first sub-heading shows. This reads, "What is 'Electrical Interference'?" and a clear and concise description follows. Step by step the reader is guided forward towards a clear understanding of everything that it is necessary for him to know—he being perhaps no great mathematician—about interference. No one who takes more than a passing interest in wireless can fail to be immensely interested in the straight-forward explanations set out, and yet, indeed, there can be few experts who will fail to be interested in the new points of view brought to his attention.

RADIO CLUBS AND SOCIETIES

Club Reports should not exceed 200 words in length and should be received First Post each Monday morning for publication in the following week's issue.

SLADE RADIO

THE fourth Annual Dinner of the Slade Radio Society was held at the Imperial Hotel, Temple Street, Birmingham, on the 6th December, 1934. In spite of the very wet evening there was a large muster. Unfortunately, Dr. Harcourt, Founder and Life President, was unable to attend, and at very short notice Mr. Wilson occupied the position of chairman. The dinner was open to members and friends, and the Trade and Press were well represented.

After a number of speeches, most of which were of rather a humorous nature, the cup was presented to Mr. G. T. Peck, who also received a replica. The latter was in connection with the direction-finding contest held during the past year. Mr. S. Phillips also received a replica, and a further one would have been presented to Mr. Walley, but he was unfortunately ill in hospital.

Mr. Chivers, who is one of the founder-members, and who acted as secretary from 1929-1934, was presented with an electric clock, and it was announced that he had now been made a life member of the Society. His wife, Mrs. Chivers, also received a bouquet of pink carnations. The evening concluded with a short musical entertainment which was under the direction of Mr. Teddie Walter.

WILLS'S CAPSTAN CIGARETTES

Flat Fifty Cardboard Box

2/5

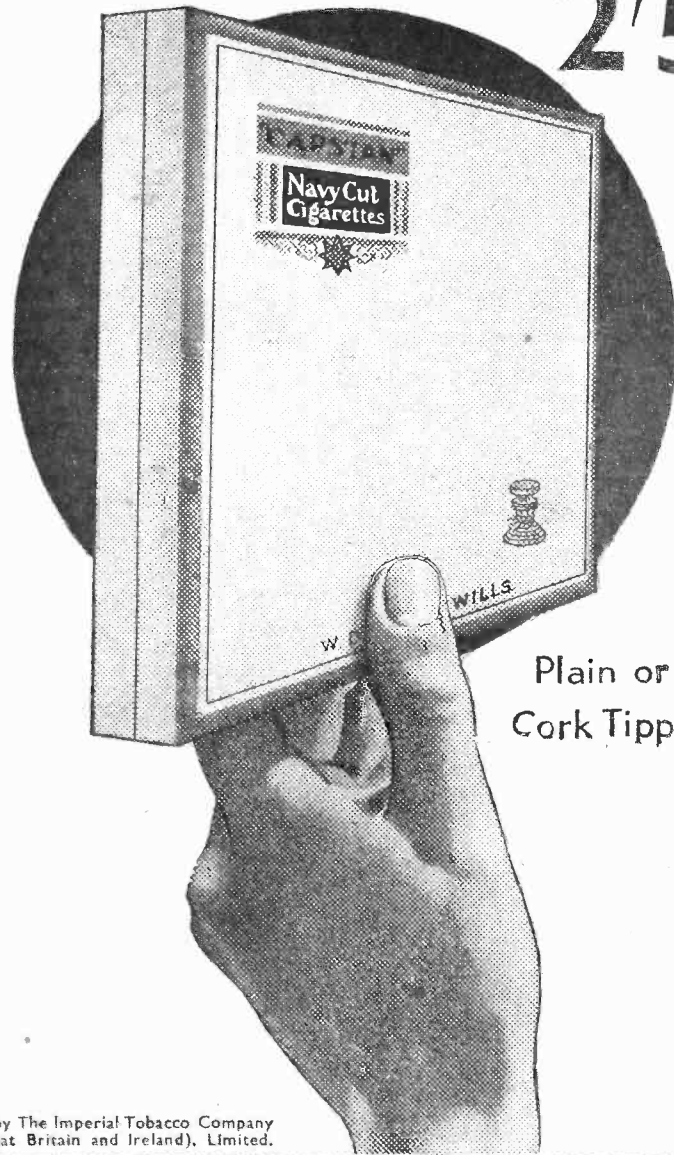

Plain or
Cork Tipped

Issued by The Imperial Tobacco Company
(of Great Britain and Ireland), Limited.

CC.460

FACTS & FIGURES

Components tested in our Laboratories

A Synchronous Turntable.

THE Simpson's synchronous electric turntable has already been most favourably commented upon in our columns. Our readers should make a note that British Radiogram are now the sole concessionaires for this product. It is fitted by means of a one-hole fixing device, and if a clockwork machine is already possessed this may be removed and the new motor easily fitted in its place, using the existing clearance hole for the spindle. It may, of course, only be used on A.C. mains. The synchronous motor is very compact, therefore taking up remarkably little space beneath the motor-board. The price has been fixed at two guineas in either 10in. or 12in. sizes, being suitable in both cases for either 200 to 250-volt mains or 100 to 150-volt mains of 50 cycles. The appropriate voltage should be specified when ordering. In operation, the turntable maintains the

increase of weight, due to the fact that no part has been cut away is unnoticeable. The whole of the surface of the disc facing the operator is finished in "camera black." The holes are cleanly cut, and a brass bush of the single-screw locking type is firmly attached to the centre. To support the motor, two sheet-steel supports are employed, and as these are finished in blue, there is no amateurish rough-assembly appearance, and it is not essential to employ a cabinet. Full instructions are enclosed to enable the amateur to put the parts together, including hints on adjusting the apparatus to obtain best results.

The neon lamp is of unusual construction, having a flat metal plate with fine wire mesh backing it, a metal frame intervening. Thus it is possible to use either type according to individual requirements. The current required for each single electrode is 30 milliamperes, but when both are

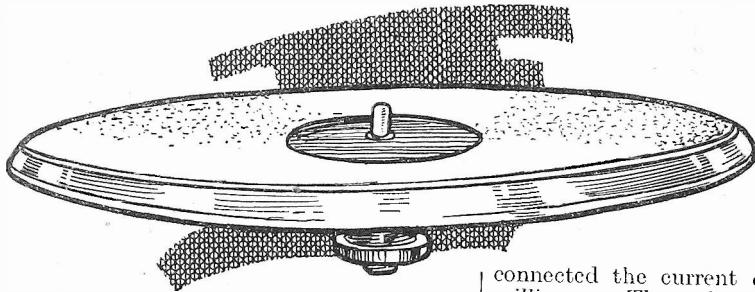

An A.C. synchronous electric turntable which is sturdily built, and is perfectly noiseless when running.

correct and constant speed of 78 r.p.m., current consumption being 5 watts. Sturdy and workmanlike in every detail of construction, it is perfectly noiseless when running. Beyond very occasional oiling of the centre bush no maintenance is required. A means of adjustment for wear is provided. This thoroughly-to-be-recommended turntable may be obtained on hire-purchase terms, if desired, from the well-known firm of Peto-Scott.

Sixty-shilling Television Kit

CONSTRUCTION has been reduced to simplest terms in the Mervyn sixty-shilling kit, the makers having gone so far as to drill the fixing holes in the wooden base, which is furthermore of skeleton construction, thus avoiding the necessity for cutting the long slot through which the disc projects. A Mervyn series-wound motor, a 15½in. scanning disc, a motor control and series resistance, a pair of motor supports, a "Nu-glo" lamp and holder, and two pairs of terminals, mounts, screws, connecting wire, etc., are all provided. The motor is of sound construction, with capped bearings, and runs smoothly without shake or tremble. The commutator is nicely finished and should give no trouble. Adjustable carbon brushes are provided.

The disc is of sheet-aluminium, giving no trouble from whip or wobble, and the slight

connected the current consumption is 55 milliamps. The makers are Mervyn Sound and Vision Co., Ltd., 4, Holborn Place, London, W.C.1.

Valve-test Adapters

ILLUSTRATED on this page is the latest Pifco product, distribution of

which has already commenced in large quantities, so that by the time this brief description appears in print supplies will no doubt be already available to the public through any good-class radio dealer. Taking the form of a set of five-to-five, to-seven, and to-nine socket adapters for

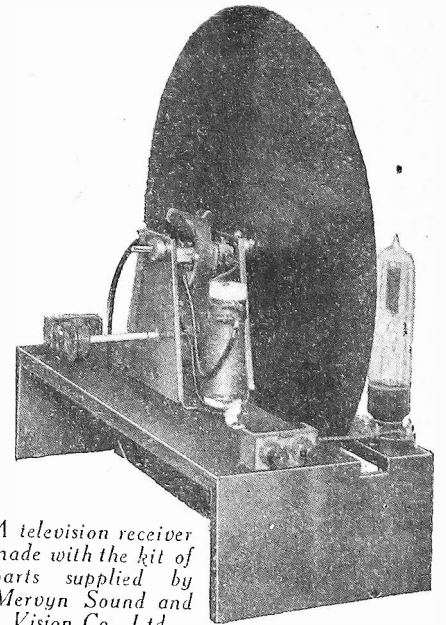

A television receiver made with the kit of parts supplied by Mervyn Sound and Vision Co. Ltd.

use in testing all five, seven, and nine-pin valves in conjunction with the well-known Pifco range of patented radio-testing instruments, this new product will be found a most useful addition to the experimenter's existing testing equipment. The illustration shows one of these sets made in black bakelite, suitably mounted with nickel-plated fittings, and supplied in a velvet-lined box. The purpose of these adapters is to test quickly the grid and anode circuits of various types of valve in conjunction with either the Pifco Rotameter-de-Luxe, the Pifco Standard Rotameter, or the Pifco Radiometer. Serious experimenters and also service men will find them particularly useful. The price has been fixed, we understand, at 15s. for the complete set as described above.

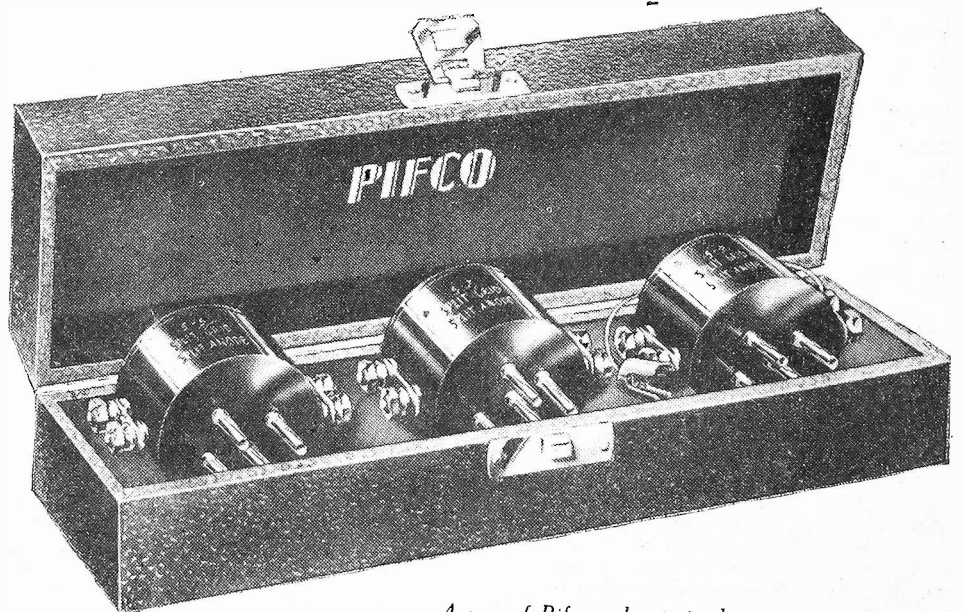

A case of Pifco valve-test adapters.

PRACTICAL LETTERS FROM READERS

The Editor does not necessarily agree with opinions expressed by his correspondents. All letters must be accompanied by the name and address of the sender (not necessarily for publication).

The £5 Superhet with Class B

SIR,—I write to let you know that I am still just as delighted as ever with the "£5 Superhet" which I constructed to your design (battery set). Desiring to use the set for gramophone records, however, and having a class B stage available, I am now using class B as the output stage of both radio and gramophone, getting an output of some 3 watts with the Mazda PD220A. You may be very interested, if not surprised, to hear that no decoupling of any kind beyond that shown in your wiring diagram—almost nothing—has been found necessary with class B—even at full volume—on radio.

The set was, and is, exactly what I required in every way, and, as I have previously stated, I have never yet seen in any periodical anywhere such a neat and efficient and up-to-date-in-every-way little set, and I congratulate you on the evolution of its design.

In conclusion I would say I am now a regular reader, and find your paper of absorbing interest, and would take this opportunity of thanking you.—A. E. HOLDAWAY (Clapham, S.W.4).

[Readers will already have noticed that a class B unit specially designed for use with the £5 Superhet was described in last week's issue.—ED.]

A High-class Receiver Wanted

SIR,—In PRACTICAL WIRELESS dated December 8th you asked if any other reader was interested in a receiver having two H.F. stages, A.V.C., push-pull output, band-pass tuning, tuning indicator, and an output of from 4 to 6 watts. It is the type of circuit I should very much like to see described in PRACTICAL WIRELESS.—G. BOXALL (Petworth).

Modifying the "Fury Four"

SIR,—We notice in your issue of December 15th, on page 502, regarding the "Fury Four" receiver that a printer's error has crept in. You actually recommend Colvern G1, 2 and 3 coils for this circuit, whereas G10, 14 and 13 should have been mentioned, vide your specification on page 905 of your issue of January 27th last.—E. S. LANCASTER, for COLVERN, LTD.

[These coils, of course, should be as stated in the specification in the issue referred to.—ED.]

Wet H.T. Batteries

SIR,—On page 498 of issue of December 15th, and under the heading "Facts and Figures," you write (in connection with wet H.T. batteries): "their messiness and the constant attention which is required in order to keep them 'topped up.'"

Well, my practical experience of these cells does not agree with that verdict.

My wet battery was installed on July 18th, 1932, and remained absolutely untouched until December 19th, 1933; it had given over 1,500 hours' service to that date, and the effective voltage per cell was still over

one volt (1.05 v.), the outside of each cell was dry and clean with no signs of "creeping salts," and if there had been any evaporation at all it was not noticeable.

The battery was re-made on December 19th, and from that day to this has not been interfered with in any way. The cells, as before, are perfectly dry and clean, and the level of the liquid is practically unaltered.

A L.T. battery installed on October 27th this year is giving every satisfaction.—C. W. BERNARD (Ballycastle, Co. Antrim).

"An Excellent Work"

SIR,—I received my copy of the "Television and Short-wave Handbook" about a week ago, but have only just found time to examine it. I have much pleasure in voting it a very excellent work indeed. Like its predecessors, it is just what every amateur has been wanting for a very long time. Again, thank you!—JAMES D. MENZIES (S.W.19).

A Short-wave Superhet.

SIR,—As a pioneer reader of PRACTICAL WIRELESS I also would like to see published a design for a short-wave superhet., or H.F. "straight" set. My occupation is that of a radio engineer, and has been for the last twelve years, and ever since the first popular short-wave boom the inquiries I have received have outnumbered the attempts to give the public a good and efficient short-wave receiver.—GEO. BLANEY (Manchester).

CUT THIS OUT EACH WEEK

Do you know

—THAT an aperiodic H.F. stage forms the simplest method of increasing the range of a short-wave receiver.

—THAT a good H.F. choke or a resistance (non-inductive) may be used in the aerial circuit of the above scheme.

—THAT when two L.F. stages are employed, the poorest form of coupling should be in the last stage.

—THAT the above arrangement avoids the amplification of signals which are not of good quality.

—THAT a good earth connection is essential in the case of mains receivers, especially those employing H.F. amplification.

—THAT a local-station "quality" receiver, with fixed tuning and remote control, is a good arrangement to adopt for household purposes, and leaves facilities for experiment on separate apparatus.

—THAT headphones should always be isolated when used with a mains receiver.

The Editor will be pleased to consider articles of a practical nature suitable for publication in PRACTICAL WIRELESS. Such articles should be written on one side of the paper only, and should contain the name and address of the sender. Whilst the Editor does not hold himself responsible for manuscripts, every effort will be made to return them if a stamped and addressed envelope is enclosed. All correspondence intended for the Editor should be addressed: The Editor, PRACTICAL WIRELESS, Geo. Newnes, Ltd., 8-11, Southampton Street, Strand, W.C.2.

Owing to the rapid progress in the design of wireless apparatus and to our efforts to keep our readers in touch with the latest developments, we give no warranty that apparatus described in our columns is not the subject of letters patent.

PETO-SCOTT AFTER XMAS BARGAINS

STENTORIAN SENIOR

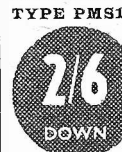

TYPE PMS1. For Power, Pentode and Class "B." Send only 2/6; balance in 11 monthly payments of 2/- Cash or C.O.D. Carriage Paid, £2/2/0.

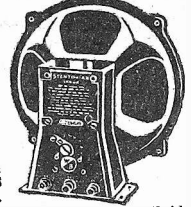

W.B. Stentorian Standard Model, Cash or C.O.D. Carriage Paid, £1/12/6, or 2/6 deposit and 11 monthly payments of 3/-.

W.B. Stentorian Baby Model, Cash or C.O.D. Carriage Paid, £1/2/6, or 2/6 deposit and 9 monthly payments of 2/6.

SIMPSON'S
ELECTRIC TURNTABLE
THE PERFECT GRAMOPHONE MOTOR AT LAST!
A more efficient or less troublesome unit is not obtainable... synchronous motor, no sparks, no brushes, electrical interference or wear, no complicated mechanisms, nothing to understand and nothing to go wrong. Low consumption, constant speed, 1-hole fixing, Darwin's Magnets, Brown-felt covered Turntable. All metal parts bronze finished. A.C. Mains only, 100/150 or 200/250 volts, 50 cycles. 12in. 42/- Cash or C.O.D. Carriage Paid.

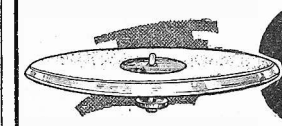

2/6 and 11 monthly payments of 4/- DOWN

B.T.S. INDIRECT DRIVE DISC TELEVISION KIT

Comprises B.T.S. Universal Ball-bearing Television Motor for Mains or Battery operation; resistances; laminated and ready assembled chassis with all component fixing holes marked. 16in. Scanning disc and stand; lens and holder; improved type TELELUX NEON Lamp and holder, full-size Blueprint, wiring and assembly instructions

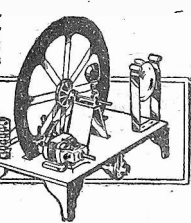

TYPE K12 for A.C. (40-60 cycles) and D.C. Mains. Cash or C.O.D., Carriage Paid, 84/-, or 10/- deposit and 11 monthly payments of 7/6.

TYPE K13 for 6-volt Battery. Cash or C.O.D. Carriage Paid, 78/- or 10/- deposit and 11 monthly payments of 6/9.

MAKE YOUR SET an ALL WAVE SET! B.T.S. 1935 SHORT-ADAPTOR WAVE



Simply plugs into your present battery or A.C. Mains set and gives world-wide reception. The only adaptor at the price incorporating 100-1 ratio aerial tuning and slow-motion reaction; for use either as Plug-in or Superhet Short-Wave metres. Extra coils, 46-96 Adaptor; Air Dielectric Condensers; and 99-260 metres, 4/6 each. Walnut Grained Bakelite Panel; YOURS 7/6 10 monthly payments of 5/-, for fully descriptive leaflet.

52/6 With 2 plug-in coils, or Superhet Short-Wave metres, 13-26 and 24-52 Adaptor; Air Dielectric Condensers; and 99-260 metres, 4/6 each. Walnut Grained Bakelite Panel; YOURS 7/6 10 monthly payments of 5/-, for fully descriptive leaflet.

ATLAS ELIMINATOR

Model T10/30. For Class B and Q.P.P. A.C. 200/250 volts, 40/120 cycles. Three tappings: 10, 20 or 30 m.a. at 120/150 volts. Trickle charger incorporated, 2 volts .5 amp. Send only 5/-; balance in 12 monthly payments of 6/- Cash or C.O.D. Carriage Paid, £3/9/6.

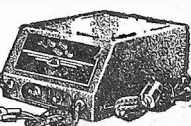

PETO-SCOTT CO., LTD. 77, PR.W.4, CITY ROAD, LONDON, E.C.1. West End Showrooms: 62, High Holborn, London, W.C.1. EST. 1919

FACTS & FIGURES

Components tested in our Laboratories

A Synchronous Turntable.

THE Simpson's synchronous electric turntable has already been most favourably commented upon in our columns. Our readers should make a note that British Radiogram are now the sole concessionaires for this product. It is fitted by means of a one-hole fixing device, and if a clockwork machine is already possessed this may be removed and the new motor easily fitted in its place, using the existing clearance hole for the spindle. It may, of course, only be used on A.C. mains. The synchronous motor is very compact, therefore taking up remarkably little space beneath the motor-board. The price has been fixed at two guineas in either 10in. or 12in. sizes, being suitable in both cases for either 200 to 250-volt mains or 100 to 150-volt mains of 50 cycles. The appropriate voltage should be specified when ordering. In operation, the turntable maintains the

increase of weight, due to the fact that no part has been cut away is unnoticeable. The whole of the surface of the disc facing the operator is finished in "camera black." The holes are cleanly cut, and a brass bush of the single-screw locking type is firmly attached to the centre. To support the motor, two sheet-steel supports are employed, and as these are finished in blue, there is no amateurish rough-assembly appearance, and it is not essential to employ a cabinet. Full instructions are enclosed to enable the amateur to put the parts together, including hints on adjusting the apparatus to obtain best results.

The neon lamp is of unusual construction, having a flat metal plate with fine wire mesh backing it, a metal frame intervening. Thus it is possible to use either type according to individual requirements. The current required for each single electrode is 30 milliamperes, but when both are

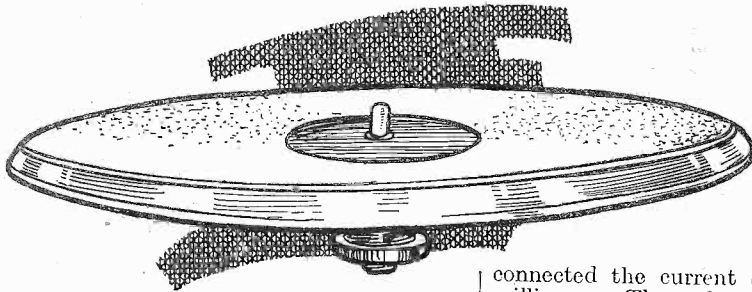

An A.C. synchronous electric turntable which is sturdily built, and is perfectly noiseless when running.

correct and constant speed of 78 r.p.m., current consumption being 5 watts. Sturdy and workmanlike in every detail of construction, it is perfectly noiseless when running. Beyond very occasional oiling of the centre bush no maintenance is required. A means of adjustment for wear is provided. This thoroughly-to-be-recommended turntable may be obtained on hire-purchase terms, if desired, from the well-known firm of Peto-Scott.

Sixty-shilling Television Kit

CONSTRUCTION has been reduced to simplest terms in the Mervyn sixty-shilling kit, the makers having gone so far as to drill the fixing holes in the wooden base, which is furthermore of skeleton construction, thus avoiding the necessity for cutting the long slot through which the disc projects. A Mervyn series-wound motor, a 15 $\frac{1}{2}$ in. scanning disc, a motor control and series resistance, a pair of motor supports, a "Nu-glo" lamp and holder, and two pairs of terminals, mounts, screws, connecting wire, etc., are all provided. The motor is of sound construction, with capped bearings, and runs smoothly without shake or tremble. The commutator is nicely finished and should give no trouble. Adjustable carbon brushes are provided.

The disc is of sheet-aluminium, giving no trouble from whip or wobble, and the slight

which has already commenced in large quantities, so that by the time this brief description appears in print supplies will no doubt be already available to the public through any good-class radio dealer. Taking the form of a set of five-to-five, to-seven, and to-nine socket adapters for

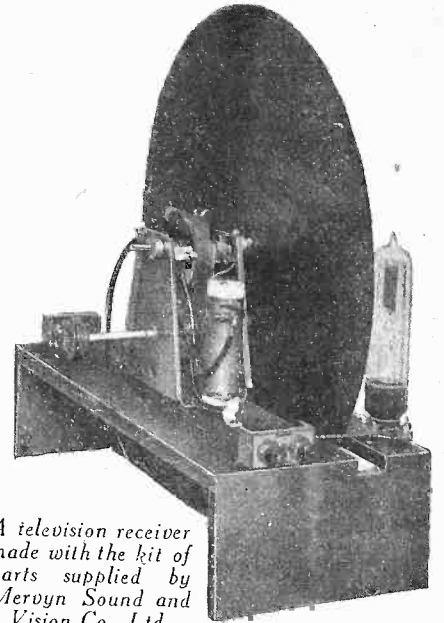

A television receiver made with the kit of parts supplied by Mervyn Sound and Vision Co. Ltd.

use in testing all five, seven, and nine-pin valves in conjunction with the well-known Pifco range of patented radio-testing instruments, this new product will be found a most useful addition to the experimenter's existing testing equipment. The illustration shows one of these sets made in black bakelite, suitably mounted with nickel-plated fittings, and supplied in a velvet-lined box. The purpose of these adapters is to test quickly the grid and anode circuits of various types of valve in conjunction with either the Pifco Rotameter-de-Luxe, the Pifco Standard Rotameter, or the Pifco Radiometer. Serious experimenters and also service men will find them particularly useful. The price has been fixed, we understand, at 15s. for the complete set as described above.

connected the current consumption is 55 milliamps. The makers are Mervyn Sound and Vision Co., Ltd., 4, Holborn Place, London, W.C.1.

Valve-test Adapters

ILLUSTRATED on this page is the latest Pifco product, distribution of

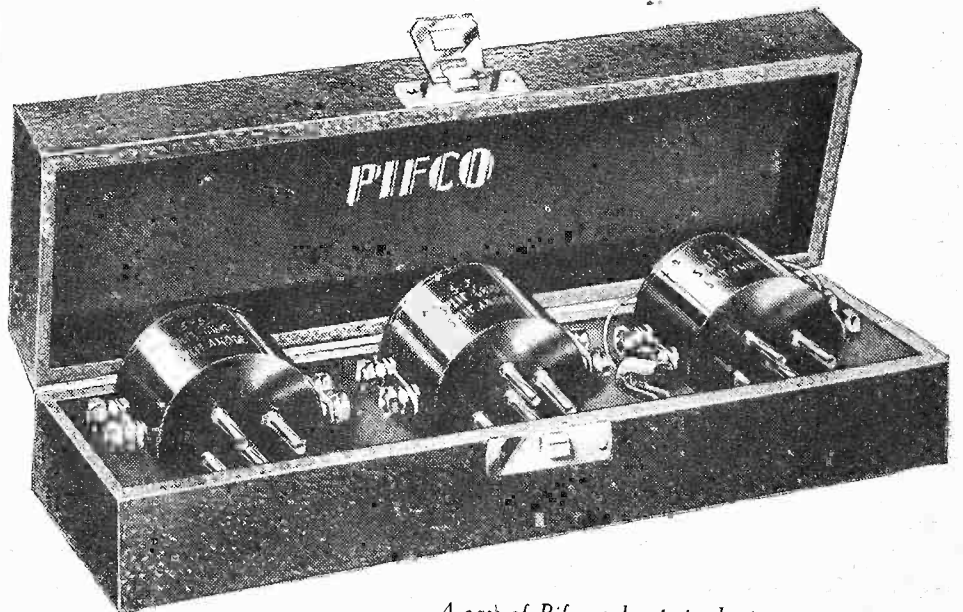

A case of Pifco valve-test adapters.

PRACTICAL LETTERS FROM READERS

The Editor does not necessarily agree with opinions expressed by his correspondents. All letters must be accompanied by the name and address of the sender (not necessarily for publication).

The £5 Superhet with Class B

SIR,—I write to let you know that I am still just as delighted as ever with the "£5 Superhet" which I constructed to your design (battery set). Desiring to use the set for gramophone records, however, and having a class B stage available, I am now using class B as the output stage of both radio and gramophone, getting an output of some 3 watts with the Mazda PD220A. You may be very interested, if not surprised, to hear that no decoupling of any kind beyond that shown in your wiring diagram—almost nothing—has been found necessary with class B—even at full volume—on radio.

The set was, and is, exactly what I required in every way, and, as I have previously stated, I have never yet seen in any periodical anywhere such a neat and efficient and up-to-date-in-every-way little set, and I congratulate you on the evolution of its design.

In conclusion I would say I am now a regular reader, and find your paper of absorbing interest, and would take this opportunity of thanking you.—A. E. HOLDAWAY (Clapham, S.W.4).

[Readers will already have noticed that a class B unit specially designed for use with the £5 Superhet was described in last week's issue.—ED.]

A High-class Receiver Wanted

SIR,—In PRACTICAL WIRELESS dated December 8th you asked if any other reader was interested in a receiver having two H.F. stages, A.V.C., push-pull output, band-pass tuning, tuning indicator, and an output of from 4 to 6 watts. It is the type of circuit I should very much like to see described in PRACTICAL WIRELESS.—G. BOXALL (Petworth).

Modifying the "Fury Four"

SIR,—We notice in your issue of December 15th, on page 502, regarding the "Fury Four" receiver that a printer's error has crept in. You actually recommend Colvern G1, 2 and 3 coils for this circuit, whereas G10, 14 and 13 should have been mentioned, vide your specification on page 905 of your issue of January 27th last.—E. S. LANCASTER, for COLVERN, LTD.

[These coils, of course, should be as stated in the specification in the issue referred to.—ED.]

Wet H.T. Batteries

SIR,—On page 498 of issue of December 15th, and under the heading "Facts and Figures," you write (in connection with wet H.T. batteries): "their messiness and the constant attention which is required in order to keep them 'topped up.'"

Well, my practical experience of these cells does not agree with that verdict.

My wet battery was installed on July 18th, 1932, and remained absolutely untouched until December 19th, 1933; it had given over 1,500 hours' service to that date, and the effective voltage per cell was still over

one volt (1.05 v.), the outside of each cell was dry and clean with no signs of "creeping salts," and if there had been any evaporation at all it was not noticeable.

The battery was re-made on December 19th, and from that day to this has not been interfered with in any way. The cells, as before, are perfectly dry and clean, and the level of the liquid is practically unaltered.

A L.T. battery installed on October 27th this year is giving every satisfaction.—C. W. BERNARD (Ballycastle, Co. Antrim).

"An Excellent Work"

SIR,—I received my copy of the "Television and Short-wave Handbook" about a week ago, but have only just found time to examine it. I have much pleasure in voting it a very excellent work indeed. Like its predecessors, it is just what every amateur has been wanting for a very long time. Again, thank you!—JAMES D. MENZIES (S.W.19).

A Short-wave Superhet.

SIR,—As a pioneer reader of PRACTICAL WIRELESS I also would like to see published a design for a short-wave superhet., or H.F. "straight" set. My occupation is that of a radio engineer, and has been for the last twelve years, and ever since the first popular short-wave boom the inquiries I have received have outnumbered the attempts to give the public a good and efficient short-wave receiver.—GEO. BLANEY (Manchester).

CUT THIS OUT EACH WEEK

Do you know

—THAT an aperiodic H.F. stage forms the simplest method of increasing the range of a short-wave receiver.

—THAT a good H.F. choke or a resistance (non-inductive) may be used in the aerial circuit of the above scheme.

—THAT when two L.F. stages are employed, the poorest form of coupling should be in the last stage.

—THAT the above arrangement avoids the amplification of signals which are not of good quality.

—THAT a good earth connection is essential in the case of mains receivers, especially those employing H.F. amplification.

—THAT a local-station "quality" receiver, with fixed tuning and remote control, is a good arrangement to adopt for household purposes, and leaves facilities for experiment on separate apparatus.

—THAT headphones should always be isolated when used with a mains receiver.

The Editor will be pleased to consider articles of a practical nature suitable for publication in PRACTICAL WIRELESS. Such articles should be written on one side of the paper only, and should contain the name and address of the sender. Whilst the Editor does not hold himself responsible for manuscripts, every effort will be made to return them if a stamped and addressed envelope is enclosed. All correspondence intended for the Editor should be addressed: The Editor, PRACTICAL WIRELESS, Geo. Newnes, Ltd., 8-11, Southampton Street, Strand, W.C.2.

Owing to the rapid progress in the design of wireless apparatus and to our efforts to keep our readers in touch with the latest developments, we give no warranty that apparatus described in our columns is not the subject of letters patent.

PETO-SCOTT AFTER XMAS BARGAINS

STENTORIAN SENIOR

TYPE PMS1. For Power, Pentode and Class "B." Send only 2/6; balance in 11 monthly payments of 2/- Cash or C.O.D. Carriage Paid, £2/2/0.

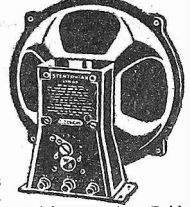

W.B. Stentorian Standard Model. Cash or C.O.D. Carriage Paid, £1/12/6, or 2/6 deposit and 11 monthly payments of 3/-. W.B. Stentorian Baby Model. Cash or C.O.D. Carriage Paid, £1/2/6, or 2/6 deposit and 9 monthly payments of 2/6.

SIMPSON'S ELECTRIC TURNTABLE

THE PERFECT GRAMOPHONE MOTOR AT LAST! A more efficient or less troublesome unit is not obtainable... synchronous motor, no sparks, no brushes, electrical interference or wear, no complicated mechanisms nothing to understand and nothing to go wrong! Low consumption, constant speed, 1-hole fixing, Darwin's Magnets, Brown-felt covered Turntable. All metal parts bronze finished. A.C. Mains only. 100/150 or 200/250 volts, 50 cycles. 12in. Cash or C.O.D. Carriage Paid, 42/-

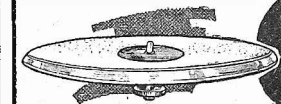

2/6 and 11 monthly payments of 4/- DOWN

B.T.S. INDIRECT DRIVE DISC TELEVISION KIT

Comprises B.T.S. Universal Ball-bearing Television Motor for Mains or Battery operation; resistances; laminated and ready assembled chassis with all component fixing holes marked. 16in. Scanning disc and stand; lens and bolder; improved type TELELUX

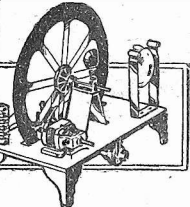

NEON Lamp and holder, full-size Blueprint, wiring and assembly instructions TYPE K12 for A.C. (40-60 cycles) and D.C. Mains. Cash or C.O.D., Carriage Paid, 84/-, or 10/- deposit and 11 monthly payments of 7/6.

TYPE K13 for 6-volt Battery. Cash or C.O.D. Carriage Paid, 78/- or 10/- deposit and 11 monthly payments of 6/9.

MAKE YOUR SET an ALL WAVE SET!

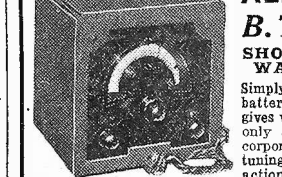

B.T.S. 1935 SHORT-ADAPTOR WAVE

Simply plugs into your present battery or A.C. Mains set and gives world-wide reception. The only adaptor at the price incorporating 100-1 ratio aerial tuning and slow-motion reaction; for use either as Plug-in or Superhet. Short-Wave metres. Extra coils, 46-96 action and Tuning Condensers; and 99-260 metres, 4/6 each. Walnut Grained Bakelite Panel; YOURS 7/6 payments of 5/- for fully descriptive leaflet.

52/6 With 2 plug-in coils, or Superhet. Short-Wave metres. 13-26 and 24-52 Adaptor; Air Dielectric Resonators. Extra coils, 46-96 action and Tuning Condensers; and 99-260 metres, 4/6 each. Walnut Grained Bakelite Panel; YOURS 7/6 payments of 5/- for fully descriptive leaflet.

ATLAS ELIMINATOR

Model T10/30. For Class B and Q.P.P. A.C. 200/250 volts, 40/120 cycles. Three tapings: 10, 20 or 30 m.a. at 120/150 volts. Trickle charger incorporated, 2 volts .5 amp. Send only 5/-; balance in 12 monthly payments of 6/- Cash or C.O.D. Carriage Paid, £3/9/6.



PETO-SCOTT CO., LTD. 77, F.R.W.4, CITY ROAD, LONDON, E.C.1. West End Showrooms: 62, High Holborn, London, W.C.1. EST. 1919

REPLIES TO

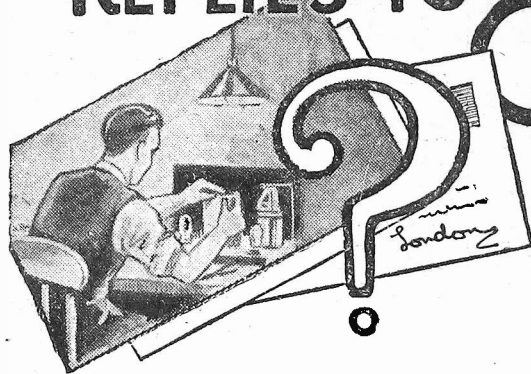
LET OUR TECHNICAL STAFF SOLVE
YOUR PROBLEMS

QUERIES and ENQUIRIES

The coupon on Cover
iii must be attached
to every query.

by Our Technical Staff

If a postal reply is desired, a stamped addressed envelope must be enclosed. Every query and drawing which is sent must bear the name and address of the sender. Send your queries to the Editor, PRACTICAL WIRELESS, Geo. Newnes, Ltd., 8-11, Southampton St., Strand, London, W.C.2.

SPECIAL NOTE

We wish to draw the reader's attention to the fact that the Queries Service is intended only for the solution of problems or difficulties arising from the construction of receivers described in our pages, from articles appearing in our pages, or on general wireless matters. We regret that we cannot, for obvious reasons—

- (1) Supply circuit diagrams of complete multi-valve receivers.
- (2) Suggest alterations or modifications of receivers described in our contemporaries.
- (3) Suggest alterations or modifications to commercial receivers.
- (4) Answer queries over the telephone.

Please note also that all sketches and drawings which are sent to us should bear the name and address of the sender.

Adding A.V.C.

"I have a ten-valve commercial radiogram of well-known make which functions very satisfactorily, but gives me a certain amount of fading on a few of the distant stations. Would you advise me to fit an A.V.C. device to this receiver, and, if so, could you please tell me how to proceed?"—W. R. S. (Leeds).

Although it might be worth while to modify your receiver to include A.V.C., we do not consider that the (rather major) alterations necessitated in your case would be justified. Further, we do not recommend readers at any time to modify commercial receivers, since there is always difficulty in following the wiring, excepting by the engineers of the firm of manufacturers. Another point is that the makers' guarantee would be invalidated by making alterations.

Difficulty with "Leader Three"

"Some time ago I built the 'Leader Three', but regret to say that results have not proved to be as good as anticipated. Reception on the long-wave band is good, but I am only able to receive about two stations on the medium waves. The components do not seem to be defective, and I would, therefore, value any assistance you can give me. I should add that I am using an eliminator which gives 120 volts for the last valve."—E. L. (Southend-on-Sea).

In the first place we wonder if the eliminator is functioning satisfactorily; if you have not already done so, we would suggest that you observe the effect of replacing this with a high-tension battery for purposes of comparison.

If the high-tension supply does not appear to be at the root of the trouble you might try the effect of transferring the aerial lead from terminal four on the first coil to terminals six and seven respectively. Should there still be no improvement, it

would probably be wise to return the coils to the makers, with a request that they should be tested.

A Long-range Receiver Wanted

"I have a fairly large cabinet of which I enclose a dimensioned sketch, and which was previously used to house a rather old-fashioned eight-valve receiver. As you will see, the depth of the cabinet from front to back is only 7½ in. I now wish to build a modern receiver, capable of good long-distance reception, and would be pleased if you could refer me to any of your designs for a suitable instrument. Also, would you please let me have a circuit and a list of parts required, advising me regarding the price of the corresponding blue print?"—H. V. (London, N.W.2).

We regret to advise you that we have not described any receiver of the type you require that could be fitted into your cabinet. In consequence of this, it will be necessary either to design and make a set of your own, or to modify the cabinet, increasing the depth. As you will see from the Special Note printed on this page, we cannot undertake to supply constructional details for receivers which have not been described in PRACTICAL WIRELESS, and we are, therefore, unable to accede to your request. We would add, however, that if you are prepared to alter the cabinet the "£5 Superhet" described in a number of recent issues would be well suited to your requirements. This receiver has been described in four forms, for battery, A.C., D.C., and universal-mains operation.

A Three-valve Receiver

"Will you please advise me of the most suitable three-valve receiver for operating a moving-coil loud-speaker, and suitable for use with either dry H.T. batteries or an eliminator?"—C. H. C. (Hillingdon).

Unfortunately, your request is very vague, since we could recommend numerous three-valve sets all of which would fit the requirements stated. If, however, you desire to have a really high-class instrument, the "£5 Superhet" described in the issues of PRACTICAL WIRELESS dated October 27th, November 3rd and 17th would be most suitable. On the other hand, if price is an important consideration, the "Hall-Mark Three" can strongly be recommended. This receiver was dealt with in the issues of PRACTICAL WIRELESS dated December 8th and 15th.

A Good A.C. Set

"Would you please advise me if the 'A.C. Leader Three' is capable of giving good reception of a fair number of stations

and of operating a Blue Spot moving-coil loud-speaker?"—D. V. (Oxford).

The receiver you mention will certainly do all that you require of it, presuming that the speaker is provided with a transformer for matching a mains power valve. As you do not state the exact type of speaker, we are unable to be more definite on this point.

Radiogram Superhet

"Would you please advise me as to a good six-valve battery radiogram, of up-to-date design and including such features as 'A.V.C.'?"—M. McL. (Glasgow).

We have not described a receiver of the type you mention and therefore regret that we are unable to give the particulars that you desire. At the same time we would point out that the "£5 Superhet Three" described in the issues of PRACTICAL WIRELESS dated October 27th, November 3rd and 17th with the addition of the class B unit described in the issue dated December 29th would be quite ideal for your purpose. This combination instrument will give extremely powerful reception of a large number of stations, besides giving ample volume on record reproduction. Automatic volume control can be added to the set by following the instructions given in the issue dated November 17th.

Coil Connections

"I recently bought a pair of dual-range coils and understood that a diagram of connections was given in the box. On opening the latter, however, I found that the diagram had been omitted. There is a name, presumably of the makers, on the box and the address: Deemark, London, S.E.4. Can you please advise me of the full address of the makers, so that I may write to them?"—B. K. (Newport, I.O.W.).

We regret to advise you that we are unable to trace the makers of the coils from the details you give, and would, therefore, suggest that you inquire of the supplier.

A G.B. Difficulty

"Enclosed is the circuit of an H.F. unit which I have recently made for use in conjunction with my three-valve receiver. You will see that grid bias is applied to the screen-grid valve from a small G.B. cell. The trouble is that after the set has been in use for a short time the G.B. cell is very warm and shows no voltage reading. Can you please tell me what is wrong?"—A. G. (Sheffield).

Your trouble is due to the G.B. cell being wrongly connected, and it is being short-circuited through the tuning coil. The lead you show going from terminal 6 to earth should be "broken" and a 0.1-mfd. fixed condenser inserted.

BIRMINGHAM RADIOMART

S ELECTION brand new perfect components; quality goods, speedy delivery, guaranteed satisfaction.

R ADIOMART. British Radiophone, 110 k.c. IF Transformers 2/6; Westinghouse skeleton HT10 manufacturers' surplus 9/9.

R ADIOMART. Lissen 2-gang coil unit for screened grid circuit, switches, makers' unopened boxes, complete circuits (list 17/6), 5/11.

R ADIOMART. Utility super 2-gang air-spaced ball-bearing, fully screened, with trimmers, 5/11; with disc dial 6/11.

R ADIOMART. Utility straight line dials, wave-length, light moves with pointer 3/6; Utility bakelite, 0.0001, 0.0002, 6d.

R ADIOMART. TCC 500v., 4 x 4 x 1 mfd., 2/11; 4 x 4 x 2 x 1 x 1 mfd., 4/6; Dubilier 4mfd 200v. electrolytics, 1/3.

R ADIOMART. Lissen 12/6 chokes 25hy., 70ma, 4/6; 32hy. output, 4/6; 3-1 Pentode output transformer, 4/6.

R ADIOMART. Special offer; dozen assorted wire-ended resistances, Dubilier NSF, etc., all different, our selection 2/6.

R ADIOMART. TCC, bias electrolytics, 50mfd, 12v. 25mfd. 25v., 1/3; 6mfd 50v. 1/-; 15mfd. 100v. 1/6.

R ADIOMART. Mains Transformers, 300-350v. 120 ma, 4v. 6 amps, 4v. 2 1/2 amps, 4v. 2 amps screened primary, super quality, made Western Electric, Sv. Crownwell superhet, 12/6; postage 1/-.

R ADIOMART. Edgewise visual tuning meter 6 ma illuminated 2 1/2 x 5 1/2 in. only, similar RGD; 5/9.

R ADIOMART. Radiophone logarithmic potentiometer, 10,000 ohms, wire wound, with mains switch 2/-.

R ADIOMART. Clarion 10/6 full vision dials, wavelenght scales moving spotlight, oxydised escutcheon 2/9.

R ADIOMART. Airspaced variable condensers; 0.0005, 1/9; 0.0003, 1/3; real quality job.

R ADIOMART. Screened iron-core dual-range coils, with reaction circuit, 2/11; Igranite short-wave iron-core dual range 3/3.

R ADIOMART. Ekco brand new D.C. 25ma eliminators 18/6; Telsen 25ma A.C. with charger, 42/-.

R ADIOMART. Latest type Telsen components, disc drives 1/9; slow motion dials 1/6.

R ADIOMART. Telsen 7/6 Radiogrand transformers 3-1 or 5-1, 3/9; tapped Pentode chokes 3/6.

R ADIOMART. Telsen 1,500v. tubular condensers, 6d.; cartridge, 6d. Telsen 1 watt wire-ended resistors 6d.

R ADIOMART. Telsen Differentials, 0.0001, 0.00015, bakelite variable, 0.0001, 0.00015, 10d.; 0.0003 1/-; 0.0005, 1/3.

R ADIOMART. Brand new condensers, eminent maker, 500v. working 4 mfd. 3/6; 2 mfd. 1/10, 1 mfd. 1/6.

R ADIOMART. 350v. working 4 mfd, 2/9; 2 mfd, 1/8; 1 mfd. 1/4; 250v. working 4 mfd. 2/3; 1 mfd. 1/2; .5 mfd. 9d.; .1 + .1, 9d.

R ADIOMART. Pushback, the only wire used by the setmakers, ready tinned and sleeved, 6yds. 9d.

R ADIOMART. 1934 Corsor Melody Maker kits, brand new, complete speaker, cabinet, valves, model 340 (list £5/7/6), 72/6.

R ADIOMART. Bulgin 1, 1 1/2, 3amp. fuses 2d.; Belling Lee plain bakelite terminals, 1d.

R ADIOMART. Magnavox "Class B" P.M. speakers 16/6; Igranite Driver transformers 1/11.

R ADIOMART. Non-inductive tubulars, wire-ended 1,500v. 0.1, 0.01, 0.02, 0.04, 0.05mfd, 6d.; Philips 0.0001, 0.001 2d.

R ADIOMART. Transformers: Igranite 8/6, Parvo 3 1/2-1 1/11; Ericsson 15/-, 1/3; Igranite Driver, 1/11.

R ADIOMART. Sonochorde 29/6, moving coil 2,500, tapped power, pentode, makers' boxes, 10/6.

R ADIOMART. Shortwave specialists' reliable gear at commonsense price, direct supervision. 6.5N1.

R ADIOMART. Isotex aerial transposition blocks for interference elimination, 8d.; set 10, 6/6.

R ADIOMART. Brass ball-bearing 100mfd. short-wave pigtail, noiseless, 1/6; brass bandsread or neutralising microvariables 1/-; extension brackets 3d.

R ADIOMART. Pye Loloss short-wave valve-holders 4-pin baseboard, 4d.; 1 1/2" Coil Forms, 4-pin 1/3, 6-pin 1/6.

R ADIOMART. Western Electric 21/- microphones, 2/9; transformer 2/6; Beehive standoff insulators 8d.

R ADIOMART. Millammeters, flush nickel 2 1/2 in., 5/9; super Radiomart, 2 1/2 in. 6/9; read AC or DC; all ranges.

R ADIOMART. Purchases over-produced stock leading Continental valve maker, super valves; sensational prices.

R ADIOMART. AC types at 4/6; HFPen, MH, MHL, VMSG, PT4, SGLA, SGHA.

R ADIOMART. American types at 4/6; UX250, UX245, UX210, UY35, UY224, UY27, 46, 2A7, 6A7, 80, 81, 56.

R ADIOMART. November list gives characteristics and hundreds of quality bargains; note please, stamp must accompany enquiries.

R ADIOMART. Orders over 6/- post free. 19, John Bright Street, Birmingham.

THE SQUARE DEALERS

**START 1935
WELL AND INSTALL A
HEAYBERD
MAINS UNIT!!**

150 VOLTS AT 15-50 MA.

Voltage regulation practically constant throughout the whole range of current. Suitable for any set from a one-valve to a seven-valve super-het, and specially suitable for Class 'B' working. **ABSOLUTELY FREE FROM ALL HUM AND BACKGROUND.**



**88/6
Model 15/50**

Send coupon together with 3d. in stamps for our latest 1935 Handbook, **MAINS POWER FOR YOUR RADIO.**

Mr. PRA

F. C. HEAYBERD & Co., 10, FINSBURY ST., LONDON, E.C.2.

SAVINGS BANK



*There was a young fellow named Sid
Always practical in all that he did;
His hobby was Wireless—
At it he was tireless—
And using FLUXITE—saved many a quid!*

See that **FLUXITE** is always by you—in the house—garage—workshop—anywhere where simple speedy soldering is needed. Used for 30 years in Government works and by the leading Engineers and Manufacturers. **OF ALL IRONMONGERS—IN TINS 4d., 8d., 1/4, and 2/8d.**

Ask to see the **FLUXITE SMALL-SPACE SOLDERING SET**—compact but substantial—complete with full instructions—7/6. Ask also for Leaflet on **CASE HARDENING STEEL** and **TEMPERING TOOLS** with Fluxite.

THE FLUXITE GUN

(Registered)

is a handy and economical tool that enables you to put the Fluxite where you want it on the soldering job and is clean and simple to use. Nothing to remove—no mess—no trouble. **Always READY FOR USE.**

Also used to project grease into grease cups, bearings, etc. Just fill the nozzle portion—half fill the cup—put together and press, as required. Price 1/6d.

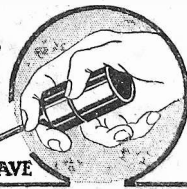

ALL MECHANICS WILL HAVE

FLUXITE

IT SIMPLIFIES ALL SOLDERING

FLUXITE LTD. (Dept. W.P.), DRAGON WORKS, BIRMINGHAM STREET, S.E.1.

RADIO CLEARANCE, 280, HIGH HOLBORN, W.C.1, offers the following stupendous bargains limited quantities only. To orders over 5/- post free. Phone: Holborn 4631.

7 VALVE Superhet Plessey Chassis made for proprietary iron whose name we are not allowed to mention; 7 tuned stages; delayed A.V.C.; local distance switch; 7 kc/s separation; Mullard valves; A.C. 200-250 volts. Demonstrations daily. Chassis complete with valves, brand new, less speaker and cabinet, £7/10/0.

RADIO CLEARANCE offers Dorchester 3 Valve Screen Grid Detector, Power, or Pentode Battery Chassis, including all first-class Components, brand new, completely wired, at 35/-, less Valves.

RADIO CLEARANCE makes special offer of a limited quantity S.T. 600 Dorchester Kits to designer's specification, including Colvern Coils, Polar Condensers, T.C.C. Fixed Condensers, R.I. Hypermite Transformer, Metallised Baseboard, Ready drilled Panel and Terminal Strip, list price, £5/17/0; our price, £3/10/0.

RADIO CLEARANCE offers 1 Watt Resistances, well-known make, all sizes, 6d. each.

RADIO CLEARANCE offers Wego 2 mfd. Condensers, canned type, 1s. each.

RADIO CLEARANCE offers 8 mfd. Dry Electrolytic 500 volt working, well-known make, 2/6 each.

RADIO CLEARANCE offers White Sleeving, 1 1/2 m.m., 9d. doz. lengths.

RADIO CLEARANCE offers Telsen 0001-00015 Reaction Condensers and 0003 Tuning Condensers 7d. each.

RADIO CLEARANCE offers British Radiophone 3-gang Condensers with 3 0005 sections, complete with Dial, Escutcheon, and Pilot Holder, 7/6 each.

RADIO CLEARANCE offers 1/25 H.P. Motors (Gilbert) 100-115 volts A.C. for Television, suitable for 200-250 Volts for use with 700 Ohm Resistances or 30 Watt Lamps, price 10/6.

RADIO CLEARANCE offers Variable Power Resistances by well-known maker, 0-100 Ohms; price 3/- each, exceptional value.

RADIO CLEARANCE offers British Radiophone Triple Gang Condensers, 2XO 0005 and 110 kc/s oscillator section complete with knob, drive, escutcheon; 7/6 post free.

RADIO CLEARANCE offers British Radiophone 110 kc/s Intermediate Frequency Transformers, 3/2.

RADIO CLEARANCE offers 8,000 Ohm Volume Controls, Log. type, with Q.M.B. switch, by G.E.C., 2/6.

RADIO CLEARANCE offers Set of Band-Pass Coils, manufacturer's type; with circuit diagram suitable for tuned grid or tuned anode; set of 3 coils, 4/6.

RADIO CLEARANCE offers Mains Transformers, unshrouded, manufacturer's type, primary 200-250, secondary 320-0-320v. at 70 m.a., 2-0-2v. at 3 amps, 6/6 post free.

RADIO CLEARANCE offers Mains Transformers, shrouded, with terminals, primary 200-250v., secondaries 320-0-320 at 70 m.a., 2-0-2 at 2 1/2a., 2-0-2 at 4 1/2a., 9/6 post free.

RADIO CLEARANCE offers I.F. Transformers, 3 : 1 and 5 : 1, manufacturer's type, 1/6 each.

RADIO CLEARANCE offers I.F. Transformers, shrouded, 3 : 1 and 5 : 1, price 1/9 each.

RADIO CLEARANCE offers Steel Chassis, cadmium plated, drilled ready for use, 3 Valve, 1/-; 4 Valve type, 1/6.

RADIO CLEARANCE offers Metal Chassis, 2-, 3- and fitted with Valve Holders and Terminal Strip, 2/-.

RADIO CLEARANCE offers "Centralab" Potentiometers, 50,000 ohms, price 1/6 each.

RADIO CLEARANCE offers T.C.C. Condensers, 0.5 mfd. 800 volt D.C. working, 1/- each; T.C.C. Condensers, 1 mfd. 450 volt D.C. working, 1/3 each; T.C.C. Condensers, 1 mfd. 800 volt D.C. working, 1/6 each; T.C.C. Condensers, 2 mfd. 405 volt working, 1/6 each; T.C.C. Condensers, 6 mfd. 250 volt D.C. working, 2/- each; T.C.C. Condensers, 6 mfd., 350 volt D.C. working, 2/6 each; T.C.C. Condensers, 4 mfd., block, 0.5, 0.5, 0.5, 0.5, 0.5, 0.5, and 1 mfd. 250 volt A.C. working, 2/6 each.

RADIO CLEARANCE, 280, High Holborn, W.C.1. Phone: Holborn 4631.

F. J. CAMM'S HALL MARK III. Send for a "Swift" Guaranteed Kit. Complete kit of parts, 30/-, postage paid (comprising B.T.S. Specified Coils, Lotus, Wavemaster and Wego Condensers, etc.). These kits do not contain any surplus or second-hand components. B.T.S. Hall-Mark III Coils, 7/6 per pair. 1 set H1VAG Valves, £1 0s. 9d. 1 ROLA F5B-PM 288 I/S, £1 5s. 0d. Immediate Delivery. Cash or C.O.D. All standard components and accessories can be supplied.—The Swift Service and Supply Co. (Dept. HM2), 3, Featherstone Buildings, High Holborn, London, W.C.1. Telephone: Holborn 1836.

HALLMARK THREE, Superhet Three, ST600 Guaranteed First Specified Kits—Lowest Prices—Easiest Terms—Lists Free.—Melfo-rad, Queen's Place, Hove. (Trade Supplied.)

MAINS Transformers, chokes, etc., to specification, repairs promptly executed. Guaranteed satisfaction. Prices on request. Henry Peace, Ltd., Wednesbury, Staffs.

Vol 5 no 112

Present your Set with a NEW BLUE SPOT SPEAKER

If your set could speak it would be effusive in its thanks for the gift of a Blue Spot Speaker. A Blue Spot Speaker enables it to give you infinitely greater enjoyment of the wireless programmes. You will be amazed at the difference in the quality of

reproduction, the astonishing sensitiveness, the delightful flexibility. Get a Blue Spot Speaker now and enjoy your Christmas Radio. Christmas is a good time to instal extension speakers and have music throughout your home. Ask your dealer.

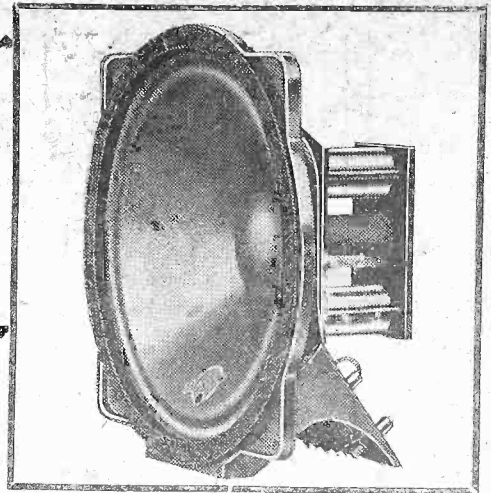

BLUE SPOT "STAR" JUNIOR

This is an exceptionally fine speaker at a very attractive price. The "Star" Junior gives a greatly extended response and the reproduction is amazingly natural and vivid in every detail of speech, song or instrumental music.

FEATURES. New Magnet design. Die cast chassis. Transformer with 12 points matching to suit all usual output stages or for use as an extension speaker.

PRICE 35/-

Cabinet model in oak and chromium 48/6.

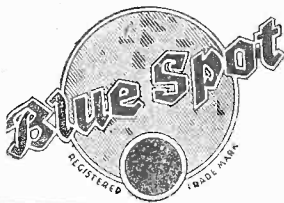

BLUE SPOT PICK-UP

This model presents many attractive features. Tracking error is reduced to the minimum. The head lifts back for needle changing, eliminating risk of damage to records. Perfect reproduction of all frequencies without overloading. Screened leads. An earth connection provided. Special Volume Control giving silent and distortionless adjustment.

Price £1.7.6, or without Volume Control £1.1.6.

Send to-day for interesting pamphlet (P.R.2), about Loudspeakers.

THE BRITISH BLUE SPOT COMPANY LTD

BLUE SPOT HOUSE · 94/96 ROSOMAN STREET · ROSEBERY AVENUE · LONDON · E.C.1
TELEPHONE: CLERKENWELL 3570. Distributors for Northern England, Scotland, and North Wales: H. C. RAWSON (Sheffield and London), Ltd., SHEFFIELD, 22, St. Mary's Parsonage, Manchester; 177, Westgate Rd., Newcastle-on-Tyne; 37, 38-39, Clyde Place, Glasgow; 45, Springbank, Hull.

Note this EDGE-ON ANODE

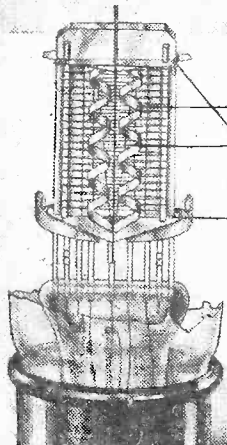

BATTERY
SG2
7/6

"Edge-on" anodes, minimising interelectrode capacity. Uniquely sprung long life filament of unusually sturdy construction. All parts completely interlocked, eliminating microphony.

It means
exceptional

PERFORMANCE

RESISTORS

50 ohms TO
100,000

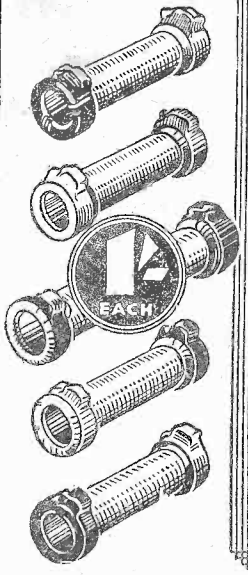

A DEFECTIVE Resistance can completely ruin the enjoyment of radio—and frequently does. Moreover, it is often difficult to trace the fault as none but the most expensive testing equipment can definitely locate it.

When building your next set, or overhauling your present equipment, change over to Amplion resistors.

They are colour coded, compact and sturdy, and all values are *wire-wound*, this method of construction giving the most reliable and constant form of resistance.

Obtainable from all Dealers.

PRICE EACH 1/- ALL VALUES



THE patent design of the anode of the 362 Battery SG2 provides exceptionally small interelectrode capacity owing to their "edge-on" construction. This valve has an unusually long straight portion to its characteristic, and can therefore be particularly recommended for a last S.G. stage. ALL 362 VALVES ARE GUARANTEED FOR 6 MONTHS. IF NOT STOCKED BY LOCAL DEALER SEND P.O. DIRECT TO US. "362" PRICES: BATTERY VALVES—H, HL & L 3/6, Power 4/-. Super Power 4/6, SG & VS 7/6, Pentode Type 10/-. BA & BX 9/-. "362" A.C. MAINS—ACH14 7/6, ACPX4 9/-. ACSV4 & ACVS4 12/6, ACME & ACHM 13/-. RB41 7/6, RB42 10/-

362
VALVES

THE 362 RADIO VALVE Co. L^{td}
STONEHAM RD., LONDON, E.S.

AMPLION (1932) LTD, 82-84, ROSOMAN STREET, LONDON, E.C.1