

TELEVISION

SERVICING · CONSTRUCTION · COLOUR · DEVELOPMENTS

25p

APRIL
1975

**VARICAP RF
MODULATOR**

CCTV CAMERA: VIDEO RECORDER: TV GAMES

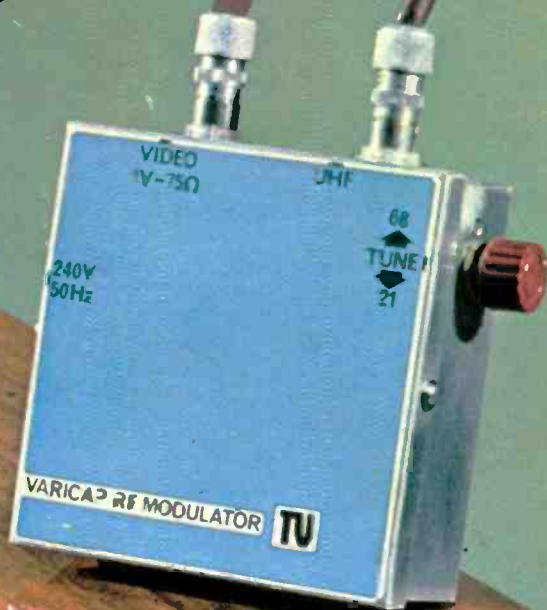

**Also
inside:-**

**COLOUR SERVICING: THORN 3000/3500 CHASSIS,
PYE HYBRID MODELS**

TV ICs: THE TBA120 AND TBA120S

FAULT-FINDING: LUMINANCE CIRCUITS

T.V. TRANSFORMER SUPPLIES

SPECIAL SPARES WHOLESALERS TO THE TV SERVICE ENGINEER

3 Green Parade, Whitton Road, Hounslow, Middx. TW3 2EN

Telephone 01-898 4083/0210

TRANSISTORS each

R2008B	£2.50
R2010B	2.50
BDX 32	2.75
SCR957	95p
BRC4443	95p
AU 113	2.00
BD 116	1.00
BC183LB	16p
E 1222	55p
Y 969	35p

DROPPERS each

BRC 1500	48p
BRC 3500	32p
BRC 8000	44p
BRC 8500	48p
PHILIPS 210	68p (pr)
BUSH colour s/s 56 ohm 68ohm	40p
PHILIPS G8	31p
GEC 2000	36p
GEC 2028	36p
BUSH 161 ser	34p

SMOOTHING CAPACITORS each

100+300+100+16	£1.10
150+100+100	1.10
150+100+50+100+100	1.80
175+100+100	1.80
1000 uf 75V	50p
140 uf 75V	35p
100 uf 64V	15p
2amp THERMAL CUT-OUTS	65p

POST PAID

WE HAVE MANY MORE LINES IN STOCK.
TRANSISTORS, EHT TRAYS COLOUR AND MONO. THORN BOARD REPAIR SERVICE
FOR BRC 2000, 3000, 3500, 8000, 8500.

LOPTS, VALVES, CAPACITORS, I.C.s,
PERSONAL CALLERS WELCOME.

ASK FOR FREE CATALOGUE

STOCK ITEMS SAME DAY DISPATCH

LINE IT UP WITH A B-P-P MARK-2 CROSS-HATCH GENERATOR

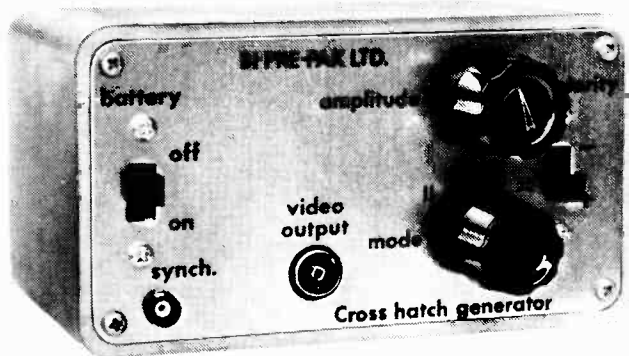

in kit form or ready-built

Based on the design originally published in "TELEVISION" this unit is invaluable to industrial and home users alike. Improved circuitry assures reliability and still better accuracy. Very compact; self-contained. Robustly built. Widely used by TV rental and other engineers. With strong metal case, instructions, but less batteries. INDISPENSABLE FOR COLOUR.

In Kit form **£7.93**

Ready built and tested **£9.93**

add 8% for V.A.T. to total value of order and inc. 15p postage and packing (in U.K.)

★TV Signal Strength Meter as described in this journal. Complete kit as specified **£19.50+40p. postage & packing+£1.59 VAT.**

- ★ 4-PATTERN SELECTOR SWITCH
- ★ SIZE 3" × 5¼" × 3" (76 × 133 × 76mm)
- ★ OPERATES FROM 3 SELF-CONTAINED U.2 TYPE BATTERIES
- ★ FUNCTIONS TO PROFESSIONAL STANDARDS

This is one of the many attractive items sold by Bi-Pre-Pak. For catalogue of these and audio modules, semi-conductor bargains, books, etc., send large S.A.E. envelope with 6p stamp.



BI-PRE-PAK LTD

(Reg. No. 820919)

Dept. X, 222-224, WEST ROAD
WESTCLIFF-ON-SEA, ESSEX SS0 9DF

Telephone: Southend (0702) 46344

BI-PRE-PAK LTD, 222 West Rd., Westcliff, Essex SS0 9DF

Please send X-Hatch Generator Kit Built

TV Signal Strength Meter

for which I enclose, £.....inc. V.A.T. & post & packing.

NAME

ADDRESS

TRANSISTORS, ETC.

Type	Price (£)	Type	Price (£)	Type	Price (£)
AC107	0.35	BC177	0.20	MPSU56	1.26
AC117	0.24	BC178	0.22	2N3133	0.54
AC126	0.25	BC178B	0.22	2N3134	0.60
AC127	0.25	BC179	0.20	2N3232	1.32
AC128	0.25	BC179B	0.21	2N3235	1.02
AC141	0.26	BC182L	0.11	2N3254	1.10
AC141K	0.27	BC183	0.11	2N3254A	0.28
AC142	0.20	BC183K	0.12	2N3391	0.23
AC142K	0.19	BC183L	0.11	2N3391A	0.23
AC151	0.24	BC184L	0.13	2N3391A	0.23
AC152	0.25	BC186	0.25	2N3391A	0.23
AC153K	0.28	BC187	0.27	2N3391A	0.23
AC154	0.20	BC208	0.12	2N3391A	0.23
AC176	0.25	BC212L	0.12	2N3391A	0.23
AC178	0.27	BC213L	0.12	2N3391A	0.23
AC187	0.25	BC214L	0.15	2N3391A	0.23
AC187K	0.25	BC238	0.10	2N3391A	0.23
AC188	0.25	BC261A	0.28	2N3391A	0.23
AC188K	0.26	BC262A	0.18	2N3391A	0.23
AC193K	0.30	BC263B	0.25	2N3391A	0.23
AC194K	0.32	BC267	0.16	2N3391A	0.23
ACY28	0.25	BC268C	0.14	2N3391A	0.23
AD140	0.68	BC294	0.37	2N3391A	0.23
AD142	0.52	BC301	0.35	2N3391A	0.23
AD143	0.51	BC303	0.60	2N3391A	0.23
AD149	0.50	BC307B	0.12	2N3391A	0.23
AD161	0.48	BC308A	0.10	2N3391A	0.23
AD162	0.48	BC309	0.15	2N3391A	0.23
AF114	0.25	BC323	0.68	2N3391A	0.23
AF115	0.25	BC377	0.22	2N3391A	0.23
AF116	0.25	BC441	1.10	2N3391A	0.23
AF117	0.20	BC461	1.58	2N3391A	0.23
AF118	0.50	BCY33	0.36	2N3391A	0.23
AF121	0.32	BCY42	0.16	2N3391A	0.23
AF124	0.25	BCY71	0.22	2N3391A	0.23
AF125	0.20	BCY88	2.42	2N3391A	0.23
AF126	0.20	BD115	0.65	2N3391A	0.23
AF127	0.20	BD123	0.98	2N3391A	0.23
AF139	0.35	BD124	0.80	2N3391A	0.23
AF147	0.35	BD130Y	1.42	2N3391A	0.23
AF149	0.45	BD131	0.45	2N3391A	0.23
AF178	0.55	BD132	0.50	2N3391A	0.23
AF179	0.60	BD135	0.40	2N3391A	0.23
AF180	0.55	BD136	0.46	2N3391A	0.23
AF181	0.50	BD137	0.48	2N3391A	0.23
AF186	0.40	BD138	0.50	2N3391A	0.23
AF239	0.40	BD139	0.55	2N3391A	0.23
AF279	0.84	BD140	0.62	2N3391A	0.23
AL100	1.10	BD144	2.19	2N3391A	0.23
AL102	1.10	BD145	0.75	2N3391A	0.23
AL103	1.10	BD163	0.67	2N3391A	0.23
AL113	0.95	BD183	0.56	2N3391A	0.23
AU103	2.10	BD410	1.65	2N3391A	0.23
AU110	1.90	2N1164	3.40	2N3391A	0.23
AU113	2.40	BD234	0.75	2N3391A	0.23
BC107	0.12	BD519	0.76	2N3391A	0.23
BC107A	0.13	BD520	0.76	2N3391A	0.23
BC107B	0.14	BDX18	1.45	2N3391A	0.23
BC108	0.12	BDX32	2.55	2N3391A	0.23
BC108B	0.13	BDY16A	0.38	2N3391A	0.23
BC109	0.13	BDY18	1.78	2N3391A	0.23
BC109C	0.14	BDY20	0.99	2N3391A	0.23
BC113	0.13	BF115	0.20	2N3391A	0.23
BC114	0.20	BF117	0.45	2N3391A	0.23
BC115	0.20	BF120	0.55	2N3391A	0.23
BC116	0.20	BF121	0.25	2N3391A	0.23
BC117	0.20	BF123	0.28	2N3391A	0.23
BC119	0.29	BF125	0.25	2N3391A	0.23
BC125	0.22	BF127	0.30	2N3391A	0.23
BC126	0.20	BF158	0.25	2N3391A	0.23
BC132	0.15	BF159	0.27	2N3391A	0.23
BC134	0.20	BF160	0.22	2N3391A	0.23
BC135	0.19	BF161	0.45	2N3391A	0.23
BC136	0.20	BF162	0.45	2N3391A	0.23
BC137	0.20	BF163	0.45	2N3391A	0.23
BC138	0.20	BF167	0.25	2N3391A	0.23
BC142	0.30	BF173	0.25	2N3391A	0.23
BC143	0.35	BF177	0.30	2N3391A	0.23
BC147	0.13	BF178	0.33	2N3391A	0.23
BC148	0.12	BF179	0.33	2N3391A	0.23
BC149	0.14	BF180	0.35	2N3391A	0.23
BC152	0.25	BF181	0.33	2N3391A	0.23
BC153	0.20	BF182	0.44	2N3391A	0.23
BC154	0.20	BF183	0.44	2N3391A	0.23
BC157	0.15	BF184	0.26	2N3391A	0.23
BC158	0.13	BF185	0.26	2N3391A	0.23
BC159	0.15	BF194	0.15	2N3391A	0.23
BC161	0.48	BF195	0.15	2N3391A	0.23
BC167B	0.15	BF196	0.15	2N3391A	0.23
BC168B	0.13	BF197	0.17	2N3391A	0.23
BC169C	0.13	BF198	0.20	2N3391A	0.23
BC170	0.15	BF199	0.25	2N3391A	0.23
BC171	0.15	BF200	0.35	2N3391A	0.23
BC172	0.14	BF218	0.35	2N3391A	0.23
BC173	0.20	BF222	1.08	2N3391A	0.23
BC174	0.26	BF224J	0.15	2N3391A	0.23
BC176	0.22	BF240	0.20	2N3391A	0.23

Tel: Stoke Climsland (05797) 439

Telex: 45457 (A/B Mercury Calgton)

DIODES

Type	Price (£)
AA113	0.15
AA119	0.09
AA129	0.20
AA143	0.30
AAZ13	0.30
AAZ17	0.12
BA100	0.15
BA102	0.25
BA110U	0.30
BA115	0.12
BA141	0.17
BA145	0.17
BA155	0.13
BA156	0.16
BA157	0.15
BAX13	0.06
BAX16	0.07
BB104	0.52
BB105B	0.52
BB105G	0.45
BR100	0.50
BY100	0.15
BY103	0.22
BY126	0.16
BY127	0.17
BY133	0.23
BY140	1.40
BY164	0.55
BY176	1.68
BY179	0.70
BY206	0.31
BYX10	0.15
BYZ12	0.30
FSY11A	0.45
FSY41A	0.40
OA10	0.20
OA47	0.07
OA81	0.12
OA90	0.08
OA91	0.07
OA95	0.07
OA200	0.10
OA202	0.10
OA210	0.29
OA237	0.28
SZM1	0.22
TV20	1.85
IN914	0.07
IN914E	0.06
IN916	0.10
IN1184	0.92
IN1185	1.10
IN4001	0.05
IN4002	0.06
IN4003	0.07
IN4004	0.08
IN4005	0.09
IN4006	0.11
IN4007	0.14
IN4148	0.05
IN4448	0.10
IN5400	0.15
IN5401	0.17
IN5402	0.20
IN5403	0.22
IN5404	0.25
IN5405	0.27
IN5406	0.30
IN5407	0.34
IS44	0.07
IS310	0.45
IS920	0.07
IS923	0.12

Diodes can be supplied balanced at a supplement of 5p per device —e.g. four balanced OA91 would be £0.48 per set. Variable capacitance diodes can be supplied matched at a supplement of 3p per device.

LINEAR INTEGRATED CIRCUITS

Type	Price (£)
MC1304	0.76
MC1305	0.76
MC1307P	1.19
MC1310P	2.94
MC1322P	1.01
MC1352P	0.82
MC1496L	0.87
MC1505P	0.58
MC1506P	0.43
MC1507P	0.43
MC1508P	0.43
MC1509P	0.43
MC1510P	0.43
MC1511P	0.43
MC1512P	0.43
MC1513P	0.43
MC1514P	0.43
MC1515P	0.43
MC1516P	0.43
MC1517P	0.43
MC1518P	0.43
MC1519P	0.43
MC1520P	0.43
MC1521P	0.43
MC1522P	0.43
MC1523P	0.43
MC1524P	0.43
MC1525P	0.43
MC1526P	0.43
MC1527P	0.43
MC1528P	0.43
MC1529P	0.43
MC1530P	0.43
MC1531P	0.43
MC1532P	0.43
MC1533P	0.43
MC1534P	0.43
MC1535P	0.43
MC1536P	0.43
MC1537P	0.43
MC1538P	0.43
MC1539P	0.43
MC1540P	0.43
MC1541P	0.43
MC1542P	0.43
MC1543P	0.43
MC1544P	0.43
MC1545P	0.43
MC1546P	0.43
MC1547P	0.43
MC1548P	0.43
MC1549P	0.43
MC1550P	0.43
MC1551P	0.43
MC1552P	0.43
MC1553P	0.43
MC1554P	0.43
MC1555P	0.43
MC1556P	0.43
MC1557P	0.43
MC1558P	0.43
MC1559P	0.43
MC1560P	0.43
MC1561P	0.43
MC1562P	0.43
MC1563P	0.43
MC1564P	0.43
MC1565P	0.43
MC1566P	0.43
MC1567P	0.43
MC1568P	0.43
MC1569P	0.43
MC1570P	0.43
MC1571P	0.43
MC1572P	0.43
MC1573P	0.43
MC1574P	0.43
MC1575P	0.43
MC1576P	0.43
MC1577P	0.43
MC1578P	0.43
MC1579P	0.43
MC1580P	0.43
MC1581P	0.43
MC1582P	0.43
MC1583P	0.43
MC1584P	0.43
MC1585P	0.43
MC1586P	0.43
MC1587P	0.43
MC1588P	0.43
MC1589P	0.43
MC1590P	0.43
MC1591P	0.43
MC1592P	0.43
MC1593P	0.43
MC1594P	0.43
MC1595P	0.43
MC1596P	0.43
MC1597P	0.43
MC1598P	0.43
MC1599P	0.43
MC1600P	0.43

DIGITAL INTEGRATED CIRCUITS

Type	Price (£)
7400	0.20
7401	0.20
7402	0.20
7403	0.20
7404	0.20
7405	0.20
7406	0.20
7407	0.20
7408	0.20
7409	0.20
7410	0.20
7411	0.20
7412	0.20
7413	0.20
7414	0.20
7415	0.20
7416	0.20
7417	0.20
7418	0.20
7419	0.20
7420	0.20
7421	0.20
7422	0.20
7423	0.20
7424	0.20
7425	0.20
7426	0.20
7427	0.20
7428	0.20
7429	0.20
7430	0.20
7431	0.20
7432	0.20
7433	0.20
7434	0.20
7435	0.20
7436	0.20
7437	0.20
7438	0.20
7439	0.20
7440	0.20
7441	0.20
7442	0.20
7443	0.20
7444	0.20
7445	0.20
7446	0.20
7447	0.20
7448	0.20
7449	0.20
7450	0.20
7451	0.20
7452	0.20
7453	0.20
7454	0.20
7455	0.20
7456	0.20
7457	0.20

The Sinclair DM2 Multimeter.

Comprehensive. Accurate. Portable. And really rugged.

Yet only £59. (PLUS VAT)



State-of-the-art circuit design, incorporating high-quality components, has resulted in a professional, $3\frac{1}{2}$ digit instrument of outstanding performance and reliability at a realistic price.

A custom-designed MOS LSI digital processing IC controls the auto-polarity dual-slope-integration A to D converter. The circuit built around this IC uses a MOSFET op-amp input buffer with 0.1% metal-film resistors. The result is excellent accuracy and stability with a very high basic input impedance.

The instrument reads to ± 1999 and has a basic accuracy on the 1 V DC range of $0.3\% \pm 1$ digit. Four 8 mm LED displays provide excellent legibility and angle of view. Battery operation allows complete independence of mains supply.

The Sinclair DM2 has all the capability you need. Just take a look at its features and compare them with higher-priced multimeters. You'll find the DM2 is their equal in virtually everything – except price!

Features of the Sinclair DM2

5 functions giving 22 ranges

DC volts – 1 mV to 1000 V
AC volts – 1 mV to 500 V
DC current – 0.1 μ A to 1 A
AC current – 1 μ A to 1 A
Resistance – 1 Ω to 20 M Ω

Easy to use

Automatic polarity, bush-button selection for all ranges and modes from a single input terminal pair.

Easy to read

Big, bright 8 mm LED display gives a quick, clear reading.

$3\frac{1}{2}$ digit display

Display reads from 000 to 1999. Overload indicator.

Protected

Separate fuses for current and resistance circuits.

Accurate

Dual slope integration. High stability.

Rugged construction

Tough metal casing takes the roughest treatment – try standing on it!

Two power sources

Supplied with a 9 V battery, giving 60-hour typical life. Mains adaptor also available.

Portable

Weights only $2\frac{1}{2}$ lb approx, including battery.

Measures only 2 in x 9 in x 6 in approx.

Optional extras

Mains adaptor – £3.19 inc VAT. Carrying case – £5.40 inc VAT.

12-month no-quibble guarantee

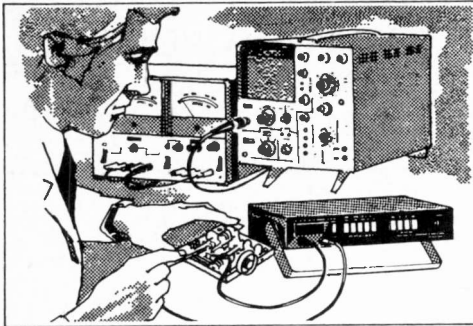

Use it in your laboratory. The DM2 sits rigidly on its combined carrying handle/stand.

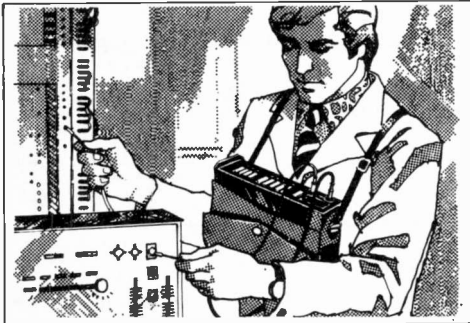

Use it on the move. Keep the DM2 in its carrying case – it's always ready for use.

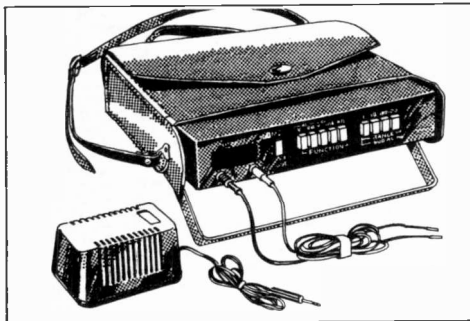

All you need to use the DM2... anywhere. Mains adaptor... carrying case... multimeter... you're ready for quick, efficient metering – whatever the situation.

Take advantage of this money-back, no-risk offer today

Test the Sinclair DM2 for yourself. Simply send us a cheque, your Access/Barclaycard number, or an official company order, with the coupon below. And in the unlikely event you find it's not what you need, return it to us within 10 days and we'll refund your money in full.

Interested in a quantity discount? Use the coupon to arrange a demonstration and get details of prices on 5 or more instruments.

Sinclair Radionics Ltd,
London Road, St Ives, Huntingdon,
Cams., PE17 4HJ.

Tel: St Ives (0480) 64646.
VAT Registration No: 213 8170 88.

The Sinclair DM2 Multimeter: full technical story

DC Volts Range	Accuracy	Input Impedance	Resolution
1 V	0.3% ± 1 Digit	> 100 MΩ	1 mV
10 V	0.5% ± 1 "	10 MΩ	10 mV
100 V	0.5% ± 1 "	10 MΩ	100 mV
1000 V	0.5% ± 1 "	10 MΩ	1 V

Maximum overload – 350 V on 1 V range
1000 V on all other ranges.

AC Volts Range	Accuracy	Input Impedance	Frequency Range
1 V	1.0% ± 2 Digits	10 MΩ/40 pF	20 Hz–3 KHz
10 V	1.0% ± 2 "	10 MΩ/40 pF	20 Hz–3 KHz
100 V	2.0% ± 2 "	10 MΩ/40 pF	20 Hz–3 KHz
1000 V	2.0% ± 2 "	10 MΩ/40 pF	20 Hz–1 KHz

Maximum overload – 300 V on 1 V range
500 V on all other ranges.

DC Current Range	Accuracy	Input Impedance	Resolution
100 μA	2.0% ± 1 Digit	10 KΩ	100 nA
1 mA	0.8% ± 1 "	1 KΩ	1 μA
10 mA	0.8% ± 1 "	100 Ω	10 μA
100 mA	0.8% ± 1 "	10 Ω	100 μA
1000 mA	2.0% ± 1 "	1 Ω	1 mA

Maximum overload – 1A (fused).

AC Current Range	Accuracy	Frequency Range
1 mA	1.5% ± 2 Digits	20 Hz–1 KHz
10 mA	1.5% ± 2 "	20 Hz–1 KHz
100 mA	1.5% ± 2 "	20 Hz–1 KHz
1000 mA	2.0% ± 2 "	20 Hz–1 KHz

Maximum overload – 1A (fused).

Resistance Range	Accuracy	Measuring Current
1 KΩ	1.0% ± 1 Digit	1 mA
10 KΩ	1.0% ± 1 "	100 μA
100 KΩ	1.0% ± 1 "	10 μA
1000 KΩ	1.0% ± 1 "	1 μA
10 MΩ	2.0% ± 1 "	100 nA

Overload protection – 50 mA (fused).

Readers outside the UK, please write for details of your local distributor to:

Sinclair Equipment International Ltd,
33 Beauchamp Place, London SW1 1NU.

To: Sinclair Radionics Ltd, FREEPOST, St Ives, Huntingdon, Cams., PE17 4BR.

Please send me:
..... Multimeters @ £63.72 inc VAT.
..... Mains adaptors @ £3.19 inc VAT.
..... Carrying cases @ £5.40 inc VAT.

*I enclose a cheque for £

*My Access/Barclaycard number:

I am interested in 5 or more multimeters.

..... Please arrange a demonstration.
..... Please send details of quantity discounts.

*I enclose an official company order – signed and dated.

*Please complete or delete as applicable.

Name

Address

Please print

FREEPOST – no stamp needed with address above.

T/3/75

sinclair

when you
want spares
yesterday...



YOU NEED
A FRIEND!

same-day despatch
is as near as
your telephone
- try it!

Stockists of genuine manufacturers spares for Rank Bush Murphy . . .
CES . . . Pye . . . Philips . . . Invicta . . . Pam . . . Ekco . . . Ferranti
BRC . . . Ferguson . . . Ultra . . . Marconi . . . HMV . . . Stockists of
TELEPART SPARES for Decca . . . KB . . . GEC . . . Sobell . . .
Masteradio . . . RGD etc. Line output transformers . . . EHT rectifier trays
Scan coil assemblies . . . Frame and sound outputs . . . Dropper sections
Entertainment valves . . . Transistors and integrated circuits . . .
Components . . . Cathode ray tubes . . . Meters . . . Test equipment . . .

willow vale
ELECTRONICS LTD

The specialist wholesaler for Service Engineers

4-5 THE BROADWAY - HANWELL LONDON W7 01-567 5400
74 MAXWELTON RD - PAISLEY RENFREW 041-887 4949
42 WEST END - STREET SOMERSET 045-84 2597

Ask for your free copy of our 68-page catalogue.

COLOUR, UHF AND TELEVISION SPARES

"TELEVISION" CONSTRUCTOR'S SIGNAL STRENGTH METER, PHILIPS G8 SURPLUS VISION SELECTIVITY PANEL 25p, VISION GAIN PANEL 25p, MULLARD ELC1043 NEW VARICAP TUNER £4.50, pp 25p (OTHER PARTS ALSO AVAILABLE). DEMONSTRATION METER WORKING AT WEST END LANE.

"TELEVISION" CONSTRUCTOR'S COLOUR SET PROJECT. NEW MARK II DEMONSTRATION MODEL WITH LATEST IMPROVEMENTS. TWO SETS WORKING AND ON VIEW AT 172 WEST END LANE, N.W.6. TREMENDOUS RELIABILITY SUCCESS OVER A YEAR. CALL, PHONE OR WRITE FOR UP-TO-DATE COLOUR LISTS.

SPECIAL OFFER I.F. Panel, leading British maker, similar design to "Television" panel. Now in use as alternative incl. circuit, and connection data, checked and tested on colour £13.80 p.p. 50p. Also DECODER panel checked and tested on colour, full details. £15.00 p.p. 55p.

CROSS HATCH unit kit, new design £3.85 p.p. 15p.
MAINS TRANSFORMER 280W, for 'Television' Colour Set. In successful use for over a year in completed sets £10.00 p.p. 90p.

PRINTED CIRCUIT BOARDS. Convergence 3 for £2.75 p.p. 45p. Decoder I.F. amp. Time Base £1.25, Power £1.50 p.p. 40p. R.G.B. Varicap, C.R.T. Base 75p p.p. 25p. Audio 60p p.p. 15p.

PACKS (incl. p.p.), No. 2 £4.90, No. 5 £1.05, No. 9 45p, No. 12 31p, No. 13 35p, No. 14 £10.85, No. 15 £2.48, No. 16 £10.95, No. 17 £2.95, No. 19 £2.50, No. 21 £10.40, No. 22 £2.20, C.R.T. Shields £2.25 p.p. 75p, Pack No. 23 £2.95, Pack No. 24 £1.25. ELC1043 £4.50, p.p. 25p. AE Isolpanel 30p, TAA550 54p p.p. 10p.

PACK No. 18, Components £8.50 p.p. 35p, also "add-on" Stabiliser Unit Kit for either 40V or 20V £3.00 p.p. 25p.

Field & Line Blanking Mod. Kit 30p, Beam Limiter Mod. Kit £1.30, CABLE 7 x 0.2 mm Screened 10 yds for 70p. Colours, 15p p.p. 10p. Line Osc. Coil 50p, 500 ohm Contrast 25p, 100 ohm W.W. 25p, 250 ohm 25W 30p, A1 Slide Switches (Break before make) 3 for 48p.

Ident Coil 50p, p.p. 12p. 100+200+200uF 350V £1.00 p.p. 25p. G.E.C. 2040 decoder panels suitable for "Television" decoder parts incl. DL20, crystal, ident coil etc., £3.50 p.p. 45p.

CRT HEATER TRANSFORMERS 6-3V/1A £1.35 p.p. 25p.
PYE 697 Line T.B. for "Television" set parts £1.50 p.p. 45p.

GEC 2040 Field/Line T.B. panels for "Television" parts £1 p.p. 45p.
MULLARD AT1023/05 convergence yoke. New £2.50 p.p. 45p.

MULLARD DLIE delay line. New £1.25 p.p. 25p.

PHILIPS G6 single standard convergence panel, incl. 16 controls, switches etc., and circuits £3.75 p.p. 45p, or incl. Yoke £5.00.

PHILIPS G8 decoder panel part complete £2.50.
Field and Line Osc. Panels for spares 75p p.p. 40p.

KB CVCI convergence control panels. New, complete £2.75 p.p. 45p.
VARICAP/VARACTOR ELC 1043 UHF tuner £4.50 p.p. 25p.

Varicap tuners salvaged, VHF or UHF £1.50 p.p. 25p. Control units. 3PSN £1.25, 4PSN £1.80, 5PSN £2.30 p.p. 20p.

UHF/625 Tuners, many different types in stock. Lists available. UHF tuners transistd. £2.85, incl. s/m drive, indicator £3.85; 6 position, or 4 position pushbutton £4.50 p.p. 40p.

MURPHY 600/700 series UHF conversion kits in cabinet plinth assembly, can be used as separate UHF receiver £5.50 p.p. 75p.

PHILIPS 625 I.F. panel incl. cct 50p, p.p. 35p.

FIREBALL TUNERS FERG, HMV, Marconi. New £1.25 p.p. 25p.

TURRET TUNERS. KB "Featherlight" VC11, Philips 170 series, GEC 2010 £2.50. AB Dual Stand, suitable Ferguson, Baird, KB, etc. 75p. Pye 110/510-Pam, Invicta, Miniature, increm. £1.00, p.p. 45p.

MULLARD TBA series I.C.S. now in stock also R.B.M.

LINE OUTPUT TRANSFORMERS. Popular types available, brand new replacements, fully guar. A selection which can be supplied p.p. 45p, C.O.D. 28p.

BUSH TV92, 93, 105 to 186SS £5.40

DECCA DR95, 101/606, DRI £5.40

2, 3, 121/123, 20/24, 2000 £5.40

EKCO, FERR. 418, 1093 series £5.40

FERG, HMV, MARCONI, £5.40

PHILCO, ULTRA, THORN £5.40

850, 900, 950, 1400, 1500 series £4.90

GEC 302 to 456, 2000 series £5.40

KB VC2/9, 51, 52, 53, 100, 200 £5.40

MURPHY 849, 939, 153 2417S £5.40

P/SCOTT 960, COSSOR 1964 £4.70

PHILIPS 19TG121 to 19TG156 £5.40

PHILIPS 19TG170, 210, 300 £5.40

PYE 110/510, 700, 830 series £4.40

11U, 20, 30, 40, 67, 368 series £5.40

PYE 169, 569, 769 series £4.90

PAM, INVICTA, EKCO, £5.40

FERRANTI, equivalents £5.40

SOBELL 1000 series £5.40

STELLA 1043/2149 £5.40

THORN 850 Time Base Panel, Dual Standard 50p. p.p. 45p.

MULLARD Scan Coils Type AT1030 for all standard mono 110° models, Philips, Stella, Pye, Ekco, Ferranti, Invicta £2.00 p.p. 45p.

CALLERS WELCOME AT SHOP PREMISES

MANOR SUPPLIES

172 WEST END LANE, LONDON, N.W.6

(Near W. Hampstead tube stn: 28, 59, 159 Bus Routes) 01-794 8751

Mail Order: 64 GOLDERS MANOR DRIVE, LONDON, N.W.11

TELEVISION

SERVICING · CONSTRUCTION · COLOUR · DEVELOPMENTS

VOL 25 No 6
ISSUE 294

APRIL 1975

ONE MAN'S SAVING . . .

The trade test transmissions on BBC-2 have been cut by some 5½ hours a day, the BBC having decided to prune its test card transmissions in the interests of its financial situation and the need to economise on the use of fuel. This action was taken without consultation with dealers' representatives and is causing the trade a great deal of trouble. Certainly the BBC will save money, but did it take into consideration the effect of the cuts on the average dealer? From the overall view it seems more than likely that the BBC's saving will be considerably less than the extra expenses incurred by the trade.

There are two problems for the trade, the loss of the test card for receiver setting up and performance appraisal, and the loss of the transmission as a marker for installation purposes. To deal with receiver setting up first, during schools transmissions both BBC-1 and ITV often carry monochrome transmissions at the same time so that without BBC-2 there is no colour available off-air. A locally generated colour-bar signal is not really the answer, first because it is difficult to judge colour performance from a row of saturated colours, while secondly the discerning customer will not be convinced that his receiver is being properly set up. The test card picture with its flesh tones has become so familiar that an experienced engineer can tell at a glance whether a set is performing correctly. Even if a colour programme is available, some of the material transmitted during the day is of doubtful quality colour-wise. Thus the absence of the test card must in the long run lead to a reduction in the standard of TV receiver performance in the home. Nevertheless if this was the only factor involved the cuts could probably be justified.

The absence of any radiation on the BBC-2 channel is a different matter however. Any installation done outside transmission hours—and this includes receivers being returned after workshop service of course—will necessitate receiver tuning by the customer, a job at which the average viewer is notoriously bad. Thus a recall when a transmission is available will frequently be necessary. Pretuning before delivery is often not practical as many dealers cover an area served by as many as four transmitters—East Sussex for example. In addition aerial erection will become a somewhat hit and miss affair.

It has been estimated (not by ourselves) that the extra work all this involves will result in additional petrol consumption of over two million gallons a year,

and on top of this a need for already hard-pressed technicians to work considerable overtime in order to cope. As most readers of TELEVISION will be all too aware, the service engineer has enough problems without the frustration of one key channel being shut down for the greater part of the working day.

The BBC's saving is resulting in an overall loss, not only financially but of the standards for which the BBC has traditionally had a proper regard: we urge them to reconsider this move.

L. E. HOWES—*Editor*.

THIS MONTH

Teletopics	246
Varicap RF Modulator	<i>by E. Trundle</i> 251
Video Circuits and Faults, Part 3—Luminance and Colour-Difference Channels	<i>by S. George</i> 256
The TBA120 and TBA120S Intercarrier Sound Channel ICs	<i>by Phosphor</i> 260
Thorn 3000/3500 Chassis: Common Faults	<i>by Paul E. Soanes</i> 263
Closed Circuit Television, Part 13	<i>by Peter Graves</i> 268
Servicing Television Receivers—Hybrid Pye Colour Sets	<i>by L. Lawry-Johns</i> 272
Long-Distance Television	<i>by Roger Bunney</i> 276
Your Problems Solved	279
Test Case 148	281

THE NEXT ISSUE DATED MAY
WILL BE PUBLISHED ON APRIL 21

TELETOPICS



TV SET DEVELOPMENTS

Despite the severe recession in the domestic TV industry and the reluctance of setmakers to tool up for and bring out new chassis there is nevertheless a great deal of development and change going on in the design of TV receivers. The main areas in which changes are taking place are in power supply circuits, colour tube designs, the introduction of more new integrated circuits specifically intended for use in TV receivers, and tuner units.

Most readers will by now be aware of stabilised power supplies using the switch-mode principle of operation. Switched thyristor rectifiers operating at mains frequency are common enough, and by now the chopper supply used in the Thorn 3000 and 3500 chassis, first introduced in 1969, is familiar. In this arrangement the series regulating element, the chopper transistor that is, is switched on and off at line frequency by the output from a monostable multivibrator. Stabilisation is achieved by altering the mark-space ratio of the multivibrator's output waveform so that the chopper is on for a longer or shorter period of time as required. The use of a monostable multivibrator to control the stabilising action has now turned up in a couple of other arrangements.

First, a particularly cunning system which is used in the ITT FT110 chassis. In this the monostable multivibrator actually forms part of the line timebase, being interposed between the line oscillator and line driver stages and operating as a pulse width modulator. Since the line oscillator output waveform in a solid-state line timebase is an approximately squarewave switching pulse which switches the line output trans-

sistor on and off, if the mark-space ratio of this pulse waveform can be varied the line timebase can be stabilised as well as any supplies obtained from the timebase by scan waveform or flyback pulse rectification. The monostable is used to provide this variable mark-space ratio drive waveform, the time-constant of its non-stable state being determined by feedback from one of the supplies obtained from the timebase. These supplies are not obtained from the line output stage itself but from a "converter" stage which is interposed between the line driver stage and the line output stage. Combining the power supply and line timebase in this way is logical enough, but whether the use of a five-stage timebase circuit with two complex transformers in addition to the driver transformer effects any particular savings is open to doubt. Anyway, the system works, it's around right now and sooner or later you're likely to come face to face with it on the workbench!

The gents at ITT are obviously convinced that this approach makes sense and have now come up with a way to apply the basic principle to thyristor line output stages. Fig. 1 shows the idea in block diagram form. First a word about the basic operation of this type of line output stage. The scan thyristor and diode pair (Th2, D2) conduct alternately during the active line period, the flyback pair (Th1, D1) taking over when the scan pair cut off during the flyback period. Energy is stored in the input coil during the flyback and then transferred to the scan circuit. The energy fed into the circuit can be controlled therefore by varying the conduction period of an additional regulating thyristor (Th3) connected between the input coil and the rest of the circuit. And to control the regulating thyristor we get back to the use of a monostable multivibrator

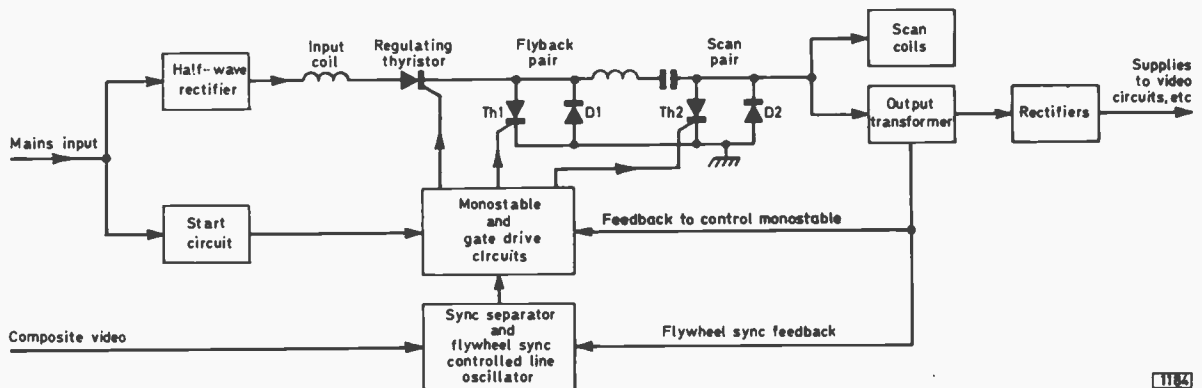

1164

Fig. 1: Combined stabilised thyristor line output stage and power supply system using a regulating thyristor driven via a variable mark-space ratio monostable circuit. System devised by ITT.

circuit. ITT have also introduced an integrated circuit, type MIC74124, which incorporates the monostable circuits required to provide correctly timed pulses to control all three thyristors. ITT say that this system is self-protecting against flashovers and other overloads, avoiding the need for a cut-out or crowbar in the power supply circuit.

A totally different approach to power supply stabilisation is adopted in the 110° Tandberg chassis. In this, a blocking oscillator is interposed between the rectified mains input and most of the supply lines in the set. A feedback loop around the blocking oscillator, which operates at a frequency well above that of the line timebase, adjusts its on-off time and thus the energy fed into the blocking oscillator transformer. Extra windings on this feed the various supply rectifiers.

The use of unusual power supply circuits is not confined to colour sets however. The latest GEC monochrome portable employs a transistor pump power supply circuit which is something entirely different again. Here the series regulating transistor is switched by pulses from the line output transformer.

On the colour tube side the self-converging PI tube (type number A51-162X) has now made its first appearance, in the latest set introduced by Korting. This is an in-line gun tube with slotted shadowmask, vertical stripe screen and permanently attached toroidal deflection coil assembly. A number of new colour tubes from Toshiba are also now making their appearance in various sets, including the Bush Model BC6100. This range of tubes covers a wide variety of permutations, about the only common factor being the use of in-line guns. Some are 90° tubes, others 110° while others are simply described as "wide-angle"; some feature vertical phosphor stripes and a slotted shadowmask while others have conventional phosphor dot screens and shadowmask, and there are black stripe versions. The Grundig Model 1510GB 14in. portable colour set is fitted with the Toshiba 370BDB22, one of the 90°/vertical stripe tubes, while the 18in. Sharp Model C1831H is fitted with the Toshiba 470EFB22P wide-angle/vertical striped screen tube with rectangular cone flare. Toshiba's own latest models, the 14in. C400B and 18in C800B, are fitted with black stripe versions of these tubes, types 370AUB22PC and 470ETB22C respectively.

There is startling news on the tuner unit front. National Semiconductor and Plessey are collaborating over the production of a digital tuner for use in TV sets. The tuners are to be sold in the UK under the Plessey name and are expected to sell to setmakers in bulk quantities for less than £13. The price is not cheap but the tuners offer a number of advantages and we could well find them in due course in luxury models. Plessey Process III bipolar i.c.s are used for frequency division, other devices used including National m.o.s. i.c.s. The tuner employs frequency synthesis techniques and incorporates a total of five i.c.s. The new approach is understood to provide a high degree of stability and sensitivity while making possible arrangements such as digital frequency readout and preprogramming.

Mention of the new Korting set also brings up another "first appearance": the chassis is the first we know in production to use the new SGS-ATES TDA440 i.c. which provides most of the vision i.f. gain, vision detection and the a.g.c. system. Another new i.c. on the i.f. panel in this set is the TCA890 which provides a.f.c.

ITT Semiconductors (Foots Cray) have introduced

a range of i.c.s specifically designed for use in TV receiver remote control systems where the control data is transmitted ultrasonically from the control unit to the set. There are 15- and 30-command devices, the range being as follows: SAA1000, a c.m.o.s. (complementary metal-oxide-semiconductor field effect transistor) i.c. for transmitting 15 control instructions at 15 different ultrasonic frequencies; the SAA1010, a silicon-gate m.o.s. i.c. for use as a 15 control channel receiver in conjunction with the SAA1000; and the SAA1024 and SAA1025 30-channel versions. To eliminate drift problems the receiver and transmitter circuits are locked to crystals (4.43MHz chrominance subcarrier frequency crystals are suggested). Thus no frequency adjustment is required at either the transmitter or receiver. The 15-channel system enables up to eight TV channels to be selected while controlling three analogue functions such as volume, colour saturation and brightness. Each analogue function has two control channels, one for positive movement, e.g. volume up, and the other for negative movement, e.g. volume down. Physical control at either the transmitter or the set is by means of touch contacts. The 30-channel system enables sixteen TV channels to be selected plus three analogue functions and set on-off, sound mute, standardise ("Granny" button) and five additional instructions such as channel indication on the screen. The circuits feature built-in immunity to spurious signals and multipath reflections, and a memory which stores the value of the analogue levels while the set is switched off so that the same conditions are present when the set is switched on again.

All of which means that there is a lot on the way to keep up with and eventually deal with.

NO MORE INVICTA SETS

One more well known TV set brand name has now disappeared. The name Invicta has been used for over forty years and for many years has been the brand name used by the Pye group for sets distributed through the wholesale trade. In future the group's Ekco brand name will be used for sets distributed through wholesalers. The Pye group, which had previously dropped the use of the names Ferranti and Pam, will now have just three brand names, Pye, Ekco and Dynatron. Whilst it is sad to see the departure of a familiar name and the traditions associated with it there nevertheless seems to be a sound case for tidying up the mass of brands and trading policies used by the radio industry. Many names have gone in recent times—Kolster Brandes, Sobell, McMichael, Philco, Cossor, Stella and Masteradio to mention just a few—and others will doubtless follow. The UK consumer industry has in the past been bedevilled by an obsession with "badge engineering", a phenomenon that is little known elsewhere. You never hear of Sony or National Panasonic sets being known as anything else for example, though Hitachi monochrome chassis are inclined to turn up under UK brand names from time to time—Pye and ITT for example. In the modern world of the multinational company it is desirable that organisations establish a single identity and reputation recognised the world over.

TANDBERG SET UP UK PLANT

Another foreign setmaker is to set up a colour receiver production plant in the UK. The Norwegian

NEXT MONTH IN

TELEVISION

AUTOMATIC TRANSISTOR TESTER

Most simple static transistor testers suffer from various disadvantages. If the collector current for a particular base current is measured to obtain a gain reading for example, the fact that a transistor's gain varies appreciably according to its collector current is not taken into account. Also, with this technique the calibration will not hold as the battery ages. It is much more satisfactory to measure the base current required to produce a fixed collector current. In most designs using this principle however the base current has to be manually set by means of a potentiometer, a critical adjustment and one that has to be done for each transistor tested. In the design to be featured next month the base current automatically adjusts to provide 1mA collector current. Both npn and pnp devices can be tested for gain, shorts and open-circuit; diodes can also be tested.

FOREIGN SET FAULTS

Dewi James reports on faults encountered in some well known imported TV sets, both colour and monochrome.

MOSFET BAND I PREAMP

Because of their excellent cross-modulation performance field effect transistors are ideal for use in preamplifiers in locations where strong local signals are present. A dual-gate m.o.s.f.e.t. is used in this design, its low feedback capacitance making neutralisation unnecessary. Another advantage is the incorporation of gate protection diodes. Trimmers are used for tuning, so that the bandwidth can be narrowed for maximum gain or widened by stagger tuning for high-definition or colour reception.

PLUS ALL THE REGULAR FEATURES

ORDER YOUR COPY ON THE FORM BELOW

TO.....
(Name of Newsagent)

Please reserve/deliver the MAY issue of TELEVISION (25p), on sale April 21st, and continue every month until further notice.

NAME

ADDRESS.....

firm Tandberg has announced that it will have a factory in operation at Haddington near Edinburgh by the summer. Initially production of 100 sets a day is aimed for. It seems that with a limited home market Tandberg have been looking for a suitable overseas location for further expansion.

MULLARD QUICK-VISION CRTs

Two quick-vision colour c.r.t.s have been introduced by Mullard. These employ a new heater-cathode assembly design as a result of which the picture appears almost immediately after switching on. Both are 110° tubes. The A56-410X is a 22in. type and the A66-410X a 26in. version. They can be used as replacements for the standard A56-140X and A66-140X tubes, enabling service departments to offer their customers "something extra". Usually all that is needed to do this is to add a shunt resistor (the new tubes have a lower heater current consumption).

TRANSMITTER OPENINGS

The following relay transmitters are now in operation. **Balgownie** (North Aberdeen): ITV (Grampian Television programmes) channel 43. Receiving aerial group B.

Henley-on-Thames: BBC-1 channel 48, BBC-2 channel 64, ITV (Thames Television and London Weekend Television programmes) channel 67. Receiving aerial group C/D.

Trawden (Lancashire): BBC-1 channel 57, ITV (Granada programmes) channel 60, BBC-2 channel 63. Receiving aerial group C/D.

Treharris (South Wales): ITV (HTV Wales programmes) channel 52. Receiving aerial group C/D.

All these transmissions are vertically polarised.

NEW WOLSEY INTRODUCTIONS

Wolsey Electronics have introduced a new range, designated the QR range, of u.h.f. aerials. These have been developed from their present ten and eighteen element designs and incorporate the existing bowtie type dipole, but with a new angled reflector assembly that gives a considerable improvement in performance. The excellent results given by the Orbit preamplifier have been mentioned before by Roger Bunney in his *Long-Distance Television* column and another unit providing similar performance but at a lower price is now available. This has a typical gain figure of 22dB and a typical noise figure of 3.5dB maximum, and differs from the Orbit only in physical screening and local signal handling capability (it is housed in a plastic case). The new preamplifier is called the Supa-Nova and wideband u.h.f. (460-860MHz) or v.h.f. (mainly for export use) versions are available. The output level is 34dBmV r.m.s. with a cross-modulation ratio of 46dB for four TV channels. The Supa-Nova costs about half the Orbit's price. There is also a new amplifier based on the Mercury design with either four or eight padded outputs so that several sets can be fed. The unit covers Band I through to Band V inclusive. To overcome cable losses a small overall gain is allowed for each output and it is felt that the simplicity of the unit will enable even the DIY enthusiast to install it successfully at any convenient point indoors. For further information write to Wolsey Electronics, Cymmer Road, Porth, Rhondda, Glamorgan.

T.V.'s & SPARES TO THE TRADE

BBC2 TVs from £2.50 each
(BRC, KB, Baird, Pye, Philips, Bush)

GEC 2000, BRC 950 (Mk II & III), Bush 141,
Philips Style 70, Baird (600 & 700 Series)
All at £7.00 each

Thorn 1400, Bush 170 Series, Philips 210,
Pye Ecko Series, Baird 673 Push Button
All at £12.50 each

PLEASE NOTE:

- ALL TUBES GUARANTEED
- ALL SETS GUARANTEED COMPLETE INSIDE AND OUT
- ALL CABINETS VERY GOOD
- ALL SETS "WALK AND TALK"
- ALL SPARES GUARANTEED FREE

COLOUR TVs—19" and 25"

Rank-Bush, Murphy, GEC, Decca, Philips, Baird, BRC
All sets with guaranteed tubes and guaranteed
complete from £65.00

Alberice 10p Slot Meters—£1.50 each

PLEASE NOTE:

1. WE STAND BY OUR GUARANTEES
2. WE DO NOT SELL RUBBISH
3. WE DELIVER ANYWHERE
4. ALL ORDERS WITH 1/3rd DEPOSIT PLEASE
5. ANY QUANTITY SUPPLIED
6. ALL PRICES SUBJECT TO V.A.T. and DELIVERY
7. NO CONNECTION WITH ANY OTHER COMPANY

WE SINCERELY AIM TO PLEASE

MAIL ORDER SERVICE

TELEVISIONS

<i>Working</i>	<i>Untested but guaranteed complete</i>
19" —£9.50	19" —£4.00
23" —£12.50	23" —£5.00

All plus p. & p., V.A.T.—£2.50
All tubes guaranteed

TUBES

19" —£3.00	} Postage and packing, V.A.T. £2.00
20" —£4.50	
23" —£4.00	
24" —£5.50	

LOPTs £2.50; VHF Tuners £2.00;
UHF Tuners—Rotary £2.50, Push Button £4.50,
plus £1.00 p. & p.
Complete Panels, I.F., etc.

**Spares available for GEC, Philips, Baird,
BRC, Bush, Baird, Pye, etc.**
Valves 12p each plus 5p p. & p. (no p. & p. on
10 valves or more)

COLOUR SPARES

Including Tubes, Panels, Tuners, LOPTs,
Cabinets, etc., etc.
Available for GEC, Baird, Philips, Decca, Bush, BRC,
prices on request.

Colour Tubes 19"—£15.00, 25"—£18.00 plus £3.50
postage and packing

ALL SPARES EX-EQUIPMENT

Speakers 6"x4", 5" Round, 8"x2" 30p each
plus 20p postage and packing

COLOUR & MONOCHROME CABINETS

available—prices on request

"VEGA" BRAND NEW TRANSISTOR RADIOS

- (in makers' cartons—fully guaranteed—less batteries)
 - Model No. 206 6SW Bands MW-LW **£15.80**
 - Model No. 201 Meridian LW-MW, S2W
 Bands **£12.70**
 - Model No. 302 LW-MW-VHF **£9.62**
 - Sapphire LW-MW-SW1 SW2 **£8.50**
 - Jade Alarm Radio LW-MW **£6.60**
 - Vega Selga 404 LW-MW **£4.70**
- All radios plus £1.00 postage and packing

CAR RADIOS—STEREOS ETC.

- Crown 200 LW/MW Manual Tune **£19.72** plus £1.00
post and packing
- Crown 300 LW/MW Push Button **£26.64** plus £1.00
post and packing
- Pye 2064 Major LW/MW Push Button **£30.00** plus
£1.00 post and packing
- Pye 2254 LW/MW Radio/Stereo Cassette excluding
speakers **£59.00** plus £1.00 post and packing
- Citizen Type LW/MW Radio/Stereo Cartridge including
speakers **£39.00** plus post and packing £1.00
- Shiboya 8 Track Stereo inc. speaker **£17.00** plus £1.00
post and packing
- Pye 2252 Cassette Stereo £32.96 plus £1.00 post and
packing

LOW PRICE CAR RADIOS

- Astor LW/MW Manual Tune **£9.50** plus £1.00 post
and packing
- Astor LW/MW Push Button **£14.50** plus £1.00 post
and packing

CAR AERIALS

Link NT4AD Fully retracting **£2.95** plus 75p post and
packing

EXTRAS

- Suppressors 1mf **65p**
- General Purpose Fitting Kits to suit crown 200, 300,
and Pye Major **£6.50** plus £1.00 post and packing
- Speaker to suit Pye 2254, 2252 **£6.90** plus £1.00 post
and packing (pair)

12 months guarantee on all items

Hoovermatic Washers and Hoover Cleaners

All items are fully stove-enamelled and rebuilt from
scratch—coming complete with a **free** formica
working top (value **£4.00**).

Guaranteed for 12 months

- Heated models **£59.00** plus £5.00 post and packing
- Unheated models **£54.00** plus £5.00 post and packing
- Vacuum Cleaners (foot-switch) **£19.00** plus £2.00
post and packing

TRADE ENQUIRIES WELCOME

ALL ORDERS WITH FULL CASH PLEASE

(Stamped addressed envelope for enquiries please)

TRADE DISTRIBUTORS (I.M.O.S.)

5 COMMERCIAL STREET · HARROGATE · YORKSHIRE Tel. No. (STD 0423) 3498

COLOUR 25 KV TRIPLERS

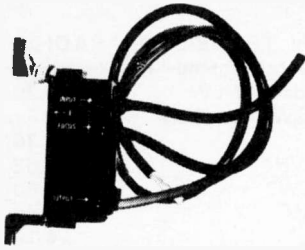

£1.70+13p V.A.T.

REPLACEMENT TRIPLERS

TS25, 11TAZ	£3.00+24p V.A.T.
G8 TRIPLERS	£3.00+24p V.A.T.
COLOUR SCAN COIL	£3.00+24p V.A.T.
I.C. SN76544N	£1.00+8p V.A.T.
BU105 Transistors	50p+4p V.A.T.

DECCA CS1730	£1.00+8p V.A.T.
--------------	-----------------

E.H.T. RECTIFIER STICKS X80/150D	10p+1p V.A.T.
-------------------------------------	---------------

PYE TRANSISTOR TUNER UNITS VHF, UHF. No push button assembly	£1.50+12p V.A.T.
---	------------------

PHILIPS UHF UNIT	£1.50+12p V.A.T.
------------------	------------------

6 OR 4 PUSH-BUTTON UHF TUNER UNIT PYE	£3.00+24p V.A.T.
--	------------------

UHF AERIAL ISOLATING CO-AX SOCKETS & LEAD	30p+2p V.A.T.
--	---------------

22 MFD, 315V/W Condensers	
25 MFD, 300V/W, 470MFD 35 V/W	
10 MFD, 250 V/W	

1000 PF 8Kv	10p+1p V.A.T.
120 PF 8Kv	10p+1p V.A.T.

200+100 MFD, 325 V/W	30p+2p V.A.T.
200+200+100, 325 V/W	40p+3p V.A.T.
200+100+50+100	40p+3p V.A.T.

300+200+100 MFD, 350 V/W	50p+4p V.A.T.
200+200+100 MFD, 350 V/W	50p+4p V.A.T.

100 W/W Resistor	£1.00+8p V.A.T.
300 Mixed Condensers	£1.00+8p V.A.T.
350 Mixed Resistors	£1.00+8p V.A.T.
40 Mixed Pots	£1.00+8p V.A.T.
5 Slider Pots	55p+4p V.A.T.

COLOUR T/V COMPONENTS

MANUFACTURERS DISCARDED MATERIALS

VHF or UHF Varicap Tuners	£1.20+9p V.A.T.
Line o.p. Panels	£1.20+9p V.A.T.
Decoder Panels	£1.00+8p V.A.T.
G8 Type Yoke	50p+4p V.A.T.
Frame Panels	75p+6p V.A.T.
IF Panels	£1.20+9p V.A.T.

Money returned if not completely satisfied

SENDZ COMPONENTS

2 WOODGRANGE CLOSE
THORPE BAY, ESSEX

5% P.P. ON ALL ORDERS

Reg Office Only—No Personal Callers Please

The Theory and Practice of PAL Colour Television in three important Sound Colour Films

- Part 1. The Colour Signal
Running time 30 mins.
- Part 2. The Receiver Decoder
Running time 25 mins.
- Part 3. Receiver Installation
Running time 25 mins.

For purchase or hire in 16mm. and Philips VCR.

Send SAE for Precis details.

ZAAR COLOUR VIDEO LTD.

339, CLIFTON DRIVE SOUTH,
ST. ANNES-ON-SEA, LANCS. FY8 1LP
TELE. (0253) 721053

Film-to-Video tape transfers specialists

ENGINEERS

FREE

YOURSELF FOR A BETTER JOB WITH MORE PAY!

Do you want promotion, a better job, higher pay? "New Opportunities" shows you how to get them through a low-cost home study course. There are no books to buy and you can pay-as-you-learn.

This helpful guide to success should be read by every ambitious engineer. Send for this helpful 76 page FREE book now. No obligation and nobody will call on you. It could be the best thing you ever did.



CUT OUT THIS COUPON

CHOOSE A BRAND NEW FUTURE HERE!

Tick or state subject of interest. Post to the address below.

Electrical Engineering	<input type="checkbox"/>	Radio Servicing, Maintenance and Repairs	<input type="checkbox"/>
Electrical Installations and wiring	<input type="checkbox"/>	Transistor Technology	<input type="checkbox"/>
Electrical Draughtsmanship	<input type="checkbox"/>	CITY AND GUILDS Installations and Wiring	<input type="checkbox"/>
Electrical Mathematics	<input type="checkbox"/>	CITY AND GUILDS Electrical Technicians	<input type="checkbox"/>
Electronic Engineering	<input type="checkbox"/>	CITY AND GUILDS Telecommunications	<input type="checkbox"/>
Computer Electronics	<input type="checkbox"/>	Radio Amateurs' Exam. etc. etc.	<input type="checkbox"/>
Computer Programming	<input type="checkbox"/>		
General Radio and TV Engineering	<input type="checkbox"/>		

To ALDERMASTON COLLEGE Dept ETV04 Reading RG7 4PE

NAME (Block Capitals Please) _____

ADDRESS _____ POST CODE _____

Other subjects _____ Age _____

Accredited by C.A.C.C. Member of A.B.C.C.

HOME OF BRITISH INSTITUTE OF ENGINEERING TECHNOLOGY

VARICAP RF MODULATOR

E. TRUNDLE

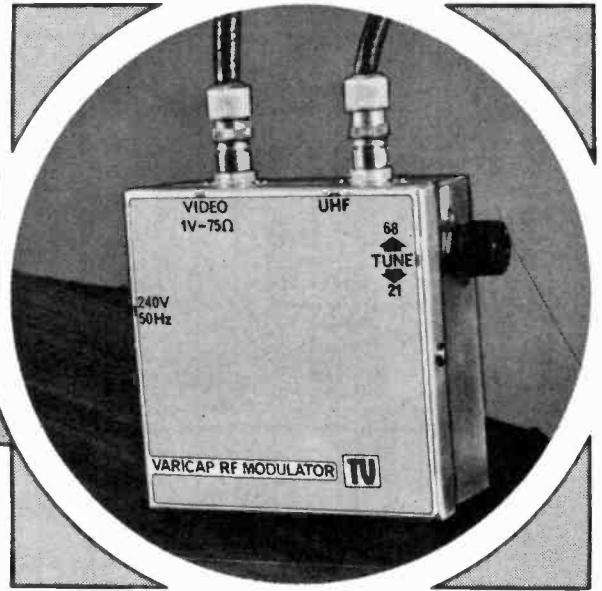

THE professional video monitor, such as is used as the display in CCTV systems, is an expensive precision device with a performance far superior to that of the mass-produced domestic TV receiver. The increasing use of video, as inexpensive vidicon cameras become available and as video recorders and electronic games become popular, has produced a demand for a cheaper, less sophisticated display.

The obvious answer is to adapt a TV receiver. Modern single-standard sets usually have gated or sync-tip a.g.c. systems plus black-level clamping or d.c. coupled video circuits, and with careful adjustment good geometry can be achieved. The only problem remaining is how the external video signal is to be introduced.

Direct connection at v.f. means that the receiver must be modified, not only to provide the input connection point but also to obtain mains isolation. The required transformer is bulky and expensive and generates an embarrassingly strong magnetic field. Its siting is therefore critical if the picture is not to be adversely affected.

The more elegant solution is to modulate the video on to a u.h.f. carrier and feed this into the receiver's aerial socket. No modifications to the set are then required and, in the event of a breakdown, any standard receiver can be quickly substituted. What is required then is a good quality modulator operating in the u.h.f. TV spectrum.

Having tried various modulators, the author became convinced that something better was needed. The usual one-transistor type has several shortcomings among which are microphony, fussy setting-up adjustments, harmonic outputs, tuning drift and so on. If the modulation process is carried out on the u.h.f. oscillator transistor, incidental frequency modulation often occurs with a consequent loss of definition.

It was felt that if the output of a u.h.f. oscillator could be applied to a tuned amplifier whose gain is varied by the video signal better results could be achieved. Alignment and tracking present great problems if the unit is built from scratch, but salvation is at hand in the form of the varicap tuner. Here we have a unit containing both a u.h.f. oscillator and a controlled gain amplifier. All that is basically necessary is to reverse their interconnections and apply the video signal to the a.g.c. input.

The ELC1043 has a convenient a.g.c. voltage/gain curve, as illustrated in Fig. 1. The standard positive-going 1V video signal provides negative modulation of the u.h.f. carrier, which is the standard form of signal for 625-line transmissions in the UK.

It was hoped to simulate exactly a u.h.f. transmission by partial suppression of the lower sideband. While this can be arranged in a set up for use on one fixed frequency, the difficulties of tracking a rejector throughout the u.h.f. band (and setting it up without specialised test gear!) led to the abandonment of this feature. Admittedly, double-sideband operation leads to an incorrect energy distribution at the vision detector, but a properly aligned i.f. strip should reject most of the lower sideband anyway and subjectively the results are quite acceptable.

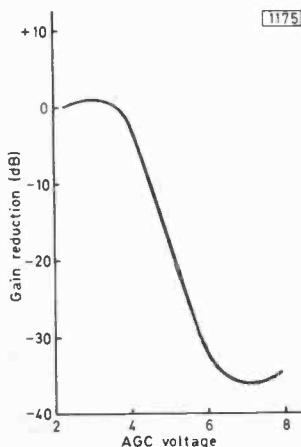

Fig. 1: Typical a.g.c. characteristic of the ELC1043 varicap tuner.

Tuner Identification

Prototypes were made using the ELC1043 and the ELC1043/05. There is a later version of the varicap tuner which looks similar externally and is interchangeable in television receivers. It has printed lecher lines, however, and is not suitable for this project. The ELC1043/05 can be identified by the horizontally

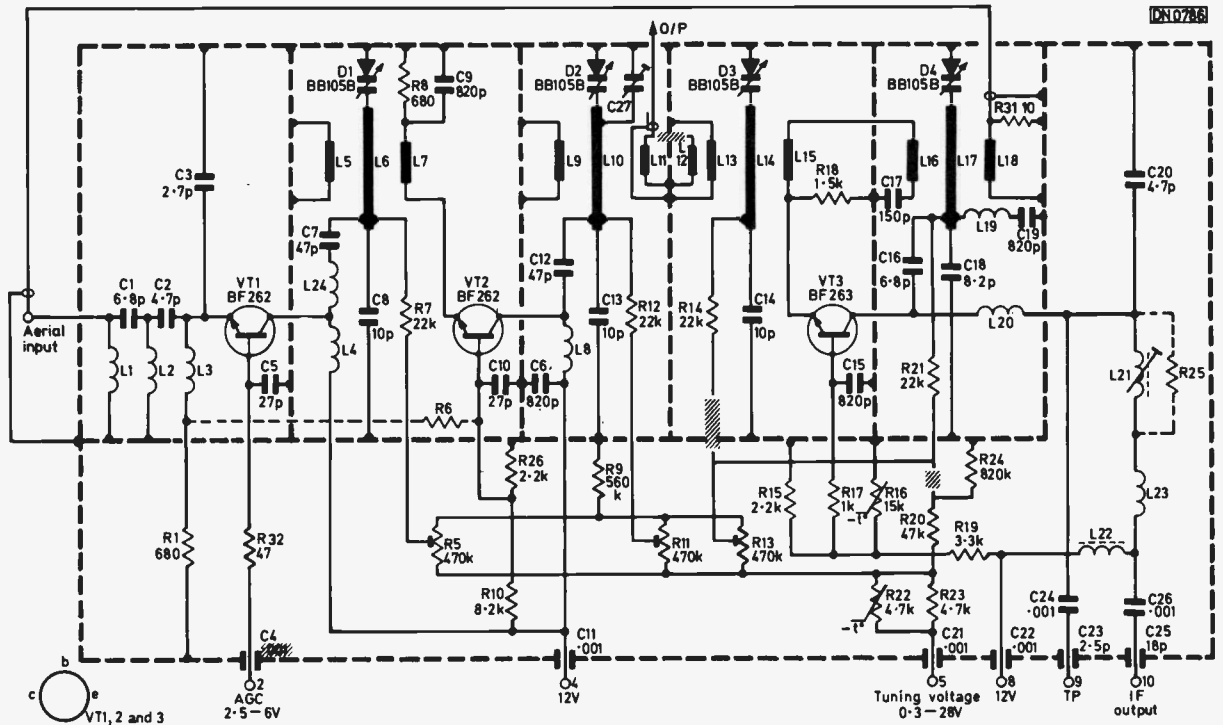

Fig. 2: Circuit of the ELC1043 after modification. The ELC1043/05 is similar apart from transistor types. The shaded areas indicate breaks in the p.c. tracks. R31 is added in series with L18 to provide the oscillator output tapping point.

mounted varicap diodes, and is the one illustrated on the front cover of the May, 1973 issue. The ELC 1043, while having the same general layout and pinning, has a totally different print pattern on the circuit board.

Modifying the Tuner

The circuit of the ELC1043 is shown in Fig. 2. The first step is to increase the bandwidth of the a.g.c. input line so that it will not attenuate the higher video frequencies. The ceramic feedthrough C4 is removed and replaced by one of a lower capacity. In the prototypes a ferrite bead was used, with the wire kinked to hold the bead in place. The 470 Ω resistor R2 must be replaced by one of 47 Ω (R32). The position of this component in the tuner depends on the type—see Fig. 3.

The output of the r.f. section is next isolated by severing the link between L11 and L12, and fitting an

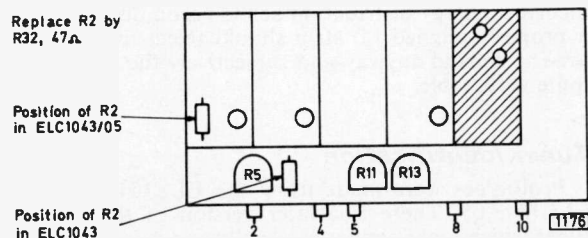

Fig. 3: Location of R2 and the three tuning presets, R5, R11 and R13.

earth bridge across the gap as in Fig. 4. The end of L11 forms the r.f. output point, and a thin screened lead is taken from here to the coaxial output socket. The vacant hole adjacent to C22 should be enlarged with a reamer or similar tool (use of a drill is likely to damage the printed circuit board) and a grommet fitted to accept the r.f. output lead.

One end of L18 is next isolated from earth and a 10 Ω non-inductive resistor, R31, fitted across the break. From the same point a screened lead is led off to the tuner's input at L1. The aerial input tag is removed altogether.

The final modification involves diverting the control potential from R13 so that it acts on D4 instead of D3. The lower end of R21 is disconnected from the junction of R20/R24 and linked to R13 slider, which must be isolated from R14.

All these alterations to the print in the tuner must be done with great care and without disturbing the physical positions of the lecher lines. The best way to remove printed tracks is to cut across the ends with a sharp single-edged razor, then scrape away the unwanted print with the back edge of a hot soldering iron. Beware of solder blobs and odd metallic slivers! In the prototypes VR1, R30 and D11 were fitted inside the tuner as well, the miniature components used presenting no problem.

Power Supplies

The power supply circuit diagram is shown in Fig. 5. A conventional full-wave rectifier and filter circuit are used to supply the 14mA or so at 12V required by the three transistors. Stabilisation is achieved by a 12V

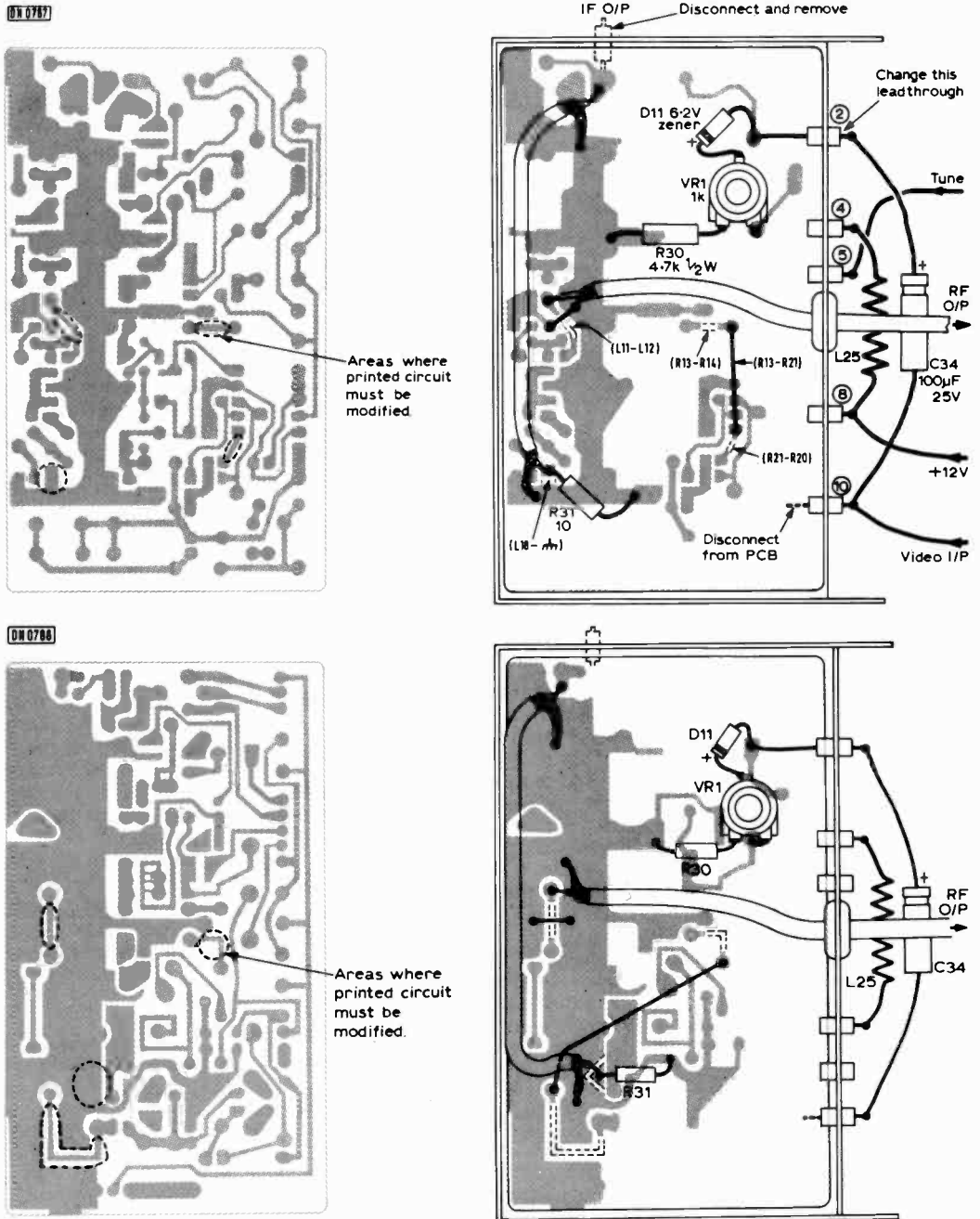

Fig. 4: Layout of the printed boards and modification details for the ELC1043/05 (top) and ELC1043 (bottom). In each case the left-hand drawing shows the print pattern before modification. The right-hand drawing shows track and components to be removed in broken line, links and components to be added in full line. Links should be made in 16 or 18 swg tinned copper wire, formed to stand clear of the board. External connections are identical for both versions.

400mW zener diode. The 30V line is derived from one half of the transformer secondary via a voltage tripler, and stabilised with a TAA550 i.c. The open-circuit voltage across C32 is 51V and for optimum stability the TAA550 bleed current is about 2.5mA. VR2 is provided to take up tolerances in individual tuners.

To achieve a satisfactorily low level of hum on the reproduced picture, filtering of the supply lines must be very good. With the component values specified the peak-to-peak ripple voltage is held down to 10mV on the 30V line and 40mV on the 12V line. L25 consists merely of a few turns of plastic insulated wire between pins 4 and 8 of the tuner.

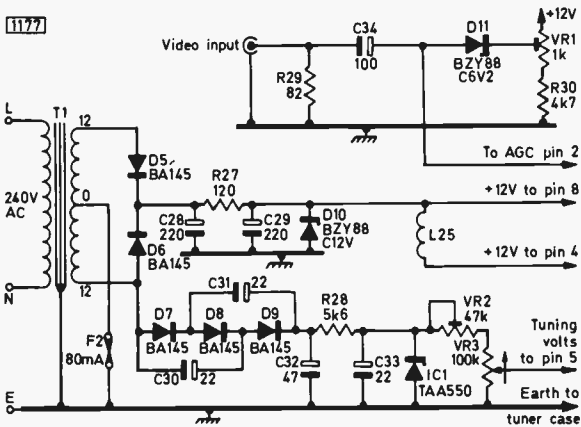

Fig. 5: Power supply and input bias circuits. Note that the fuse should be labelled F1.

Construction

The unit can be built into a TV camera if there is room. The prototype was built in an aluminium box 102×102×38mm (4×4×1½in.), made by Norman Rose Ltd., and available through component shops. A suggested layout for this version is given in Fig. 6.

The mains transformer is about 25mm (1in.) cube, and the output fuse must not be omitted. If the mains plug is fused, the lowest available rating should be fitted. The tuner was sandwiched between 12mm (½in.) layers of plastic foam glued to the top and bottom of the case. The group panel containing the power supply components was held in place, with a cardboard insulator fitted underneath, by two 4BA self-tapping screws, which bite nicely into the paxolin. Again, if the small version is to be built, the capacitors in the voltage tripler and filters should be small modern types with sleeved bodies.

The i.f. output pin was cut inside the tuner and used as an external anchor point for the video coupling capacitor C34. A cardboard insulator was fitted under the tin lid on the component side of the tuner to avoid inductance changes in the tuned circuits when the lid is pressed down during assembly.

Alignment

If the tuner is pre-aligned the settings of R5 and R11 need not be disturbed. The two r.f. amplifiers will track correctly throughout Bands IV and V and the oscillator frequency, which is normally above the incoming r.f., is reduced until it comes into line with the r.f. amplifier.

To do this, adjust the tuner to about 720MHz by means of the Tune potentiometer, VR3. This corresponds to about 13V at pin 5. Set VR1 at mid-point then apply a video signal to the input socket and monitor the output, via an attenuator, on a TV set or field strength meter. Adjust R13 for minimum snow on the TV screen or maximum field strength. As the circuits come into line, more attenuation may be required to keep the output within bounds. Next turn VR3 almost fully up and adjust VR2 so that the output is on Channel 68.

The final adjustment is to VR1. At one extreme, peak whites will be crushed, giving a limiting effect similar

to the action of a white spot limiter on an early TV receiver. At the other extreme, sync compression will take place, with line pulling and frame roll. Adjust VR1 for freedom from both these effects. It is important for this adjustment that the video input does not exceed 1.2V peak-to-peak, and that sufficient attenuation is provided in the r.f. output line to avoid overloading the monitor receiver.

Slight trimming of R5 and R11 might be required if the output drops significantly at any part of the u.h.f. band, but this was found necessary on only one of the three prototypes built. Once adjusted, all presets can be sealed as they will not need to be touched again.

Performance and Use

The zener D11 helps to maintain the d.c. level, and black level performance was found to be satisfactory. The unit was tested with several cameras and with the video output of a Philips PM5509 pattern generator. PAL-encoded colour signals were handled most satisfactorily.

The almost complete absence of spurious and harmonic outputs enabled the r.f. signal to be piped around a workshop distribution system without interfering with the normal broadcast transmission signals. This means that for security or baby-watch purposes the output from the modulator can be dplexed into the aerial feed of the domestic TV, and a fourth button tuned to the unit's output.

The r.f. output level is usually of the order of several millivolts and, depending upon the receiver, a fixed attenuator may need to be fitted at the output. If it is desired to feed several sets, sufficient output is available for a passive splitter, in the form of a star network, to distribute the signal to up to three or four receivers.

★ Components list

Resistors: (all ±5%, ¼W.)

R27	120 Ω	R30	4.7k Ω
R28	5.6k Ω	R31	10 Ω (must be non-inductive)
R29	82 Ω	R32	47 Ω (replaces R2, 470 Ω)

Potentiometers:

VR1	1k Ω	VR2	47k Ω min. carbon presets
VR3	100k Ω carbon linear		

Capacitors: (all electrolytic)

C28, C29	220µF, 25V	C33	22µF, 63V
C30, C31	22µF, 35V	C34	100µF, 25V
C32	47µF, 63V		

Semiconductors:

IC1	TAA550	D10	BZY88 C12V
D5-D9	BA145, BA148	D11	BZY88 C6V2
	or BY206		

Miscellaneous:

T1 12-0-12V 50mA subminiature mains transformer.
 F1 80mA 20mm A/s fuse and holder. L25—see text.
 2 surface mounting coaxial sockets. Aluminium box
 102×102×38mm (4×4×1½in.). Varicap tuner
 ELC1043 or ELC1043/05.

It should be verified that the monitor receiver is connected so that the chassis is at mains neutral potential, because the earthed r.f. output lead from the modulator can cause an alarming "tingle" via the TV's aerial isolation components. Overload usually occurs at about 1.3V peak-to-peak input with consequent signal compression, so the video source must be correctly adjusted to give 1V when terminated in 75 Ω . While the unit is compatible with any 1V source of composite video, it cannot be used with the cross-hatch generator design in the September, 1972 issue because this requires the receiver to be synchronised by an off-air transmission.

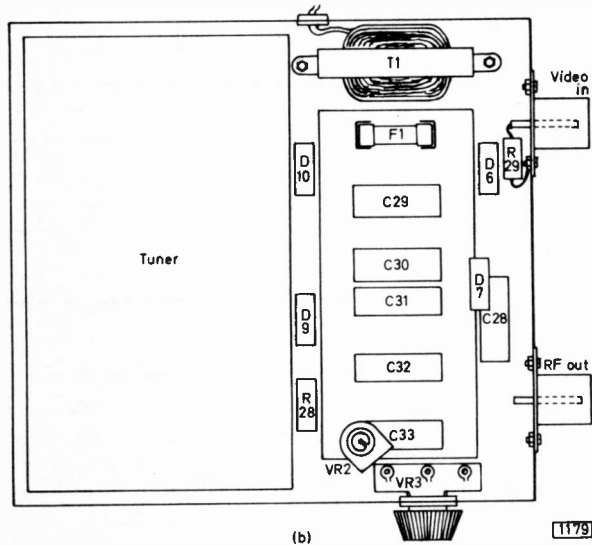
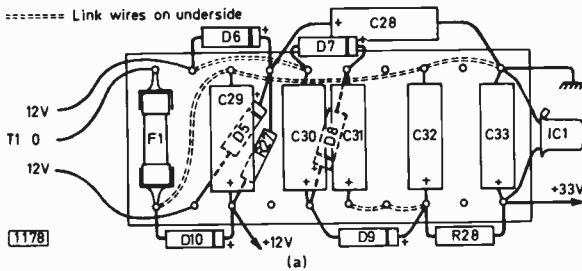

Fig. 6: (a) Layout of the power supply on a small tagboard. (b) Arrangement of the prototype modulator unit.

There is no reason why a conventional TV type tuning switch/potentiometer bank cannot be used in place of VR3. Another useful addition would be the channel meter by Alan Reekie in the November, 1974 issue. Incorporation of either of these features would probably require a larger case however.

Finally a word about earthing. If the camera and modulator are independently earthed, hum loops can be set up causing horizontal bars on the picture. Some experiment with the earthing point may be necessary to eliminate this effect.

THORN 3000/3500 CHASSIS

continued from page 267

here is worth noting. The 7.8kHz ident signal is squared and used to operate the PAL switch, the switch's earth return current being smoothed to provide the chrominance turn-on voltage. The tuning of the ident coil (L303) is critical: it should be adjusted for maximum output at the collector of the ident amplifier VT306, using an oscilloscope to monitor the 7.8kHz signal. If it is impossible to get adequate output from VT306 check the decoupling electrolytic C321 (0.22 μ F) in its emitter circuit. If the coil is not correctly tuned there will be colour streaks on the right-hand side of the screen. The coil also tends to move on its former with the result that there is a vertical stripe of incorrect colour on the left- or right-hand side of the screen depending on whether the coil has moved downwards or upwards. It should be 0.45in. from the top of the former.

No colour is often caused by the pulse polarity splitter transistor VT308 going open-circuit. This drives the burst blanking diodes and also provides the burst gating pulse. If C337 (0.47 μ F) which feeds pulses from the collector of VT308 to the burst blanking circuit is leaky the picture will be tinted blue (becomes more marked as the colour control is advanced). If the diodes which clip the pulse waveform fed to the base of VT308 are faulty the chrominance can disappear from the right-hand edge of the picture.

To over-ride the colour killer connect an 82k Ω resistor from the junction of the ident coil tuning capacitors C323, C324 to chassis.

It must not be overlooked that the line hold control setting is critical for good colour reception.

Convergence Panels

As with most convergence units, noisy potentiometers are a common fault. If the blue line tilt and amplitude controls have insufficient range check the 10 μ F electrolytic C704 (3000 chassis).

The pincushion distortion correction transductor T751 going short-circuit is a problem on the 3500 chassis. The result is smoke, damage to the associated resistors and fuse blowing. There is also a tendency on this unit for R773 (120 Ω) which feeds line frequency pulses to the transductor to burn up. Replacing it with a wirewound type stops this trouble.

CORRECTION

In *Workshop Hints*, December 1974 it was stated that "many plastics are thermosetting which means that they will melt if subjected to excessive heat". The word thermoplastic should have been used, not thermosetting. Thermosetting materials are made soft and plastic when initially heated, but after moulding to shape and the application of further heat they set hard as a result of chemical change and will not soften afterwards on being reheated. Thermoplastic materials will soften whenever sufficient heat is applied to them.

VIDEO CIRCUITS AND FAULTS

PART 3: LUMINANCE AND COLOUR-DIFFERENCE CHANNELS

S. GEORGE

WHEN we come to colour sets it is necessary to distinguish between those using colour-difference tube drive and those using RGB tube drive. In the former the luminance signal, which corresponds with the video signal in a monochrome receiver, drives the cathodes of the c.r.t. while the colour-difference signals are applied to the c.r.t. grids. Thus the c.r.t. itself acts as the matrix which recovers the RGB primary-colour signals. In the latter the luminance and colour-difference signals are matrixed to produce the RGB signals prior to application to the c.r.t., which is generally cathode driven by these signals. In the present article we will deal with the circuitry used in sets with colour-difference c.r.t. drive, leaving RGB drive circuitry to the concluding part next month.

Luminance Channel

The luminance channel in a set using colour-difference tube drive extends from the video/luminance detector to the c.r.t. cathodes and is rather more complex than the circuitry used in monochrome receivers. The main differences and additions can be summarised as follows:

- (1) One or more transistor stages are used between the detector and the luminance output stage, which in sets with colour-difference c.r.t. drive generally consists of a PL802 output pentode. The transistor preamplifier stages are required mainly to provide suitable points to feed the a.g.c. circuit, the sync separator and the chrominance channel.
- (2) A delay line—the average delay is $0.6\mu\text{s}$ —is required in the luminance channel. This is necessary since whilst the luminance channel has virtually the full video bandwidth the chrominance circuits have a much narrower bandwidth ($\pm 1\text{MHz}$): signals pass more quickly through wideband circuits than narrow-band circuits and without the compensating delay line in the luminance channel the two signals would not register on the c.r.t. screen.
- (3) The luminance drive to the three shadowmask tube cathodes must be adjustable in order to compensate for the differing red, green and blue phosphor light output efficiencies and the gun characteristics.
- (4) A trap tuned to the chrominance subcarrier frequency (4.43MHz) must be included to prevent this signal causing excessive dot patterning on high saturation colours.
- (5) The brightness control circuit must be arranged to produce balanced beam currents and prevent picture tinting as the control is varied. This means that it must set the level of the drive applied to the c.r.t.
- (6) Beam limiting is required in order to prevent too great a drop in the e.h.t. voltage if the c.r.t. current rises to an excessive level. This is often undertaken in the luminance channel.

(7) Flyback blanking is usually carried out in the luminance channel.

Two well known UK made chassis using colour-difference tube drive are the Philips G6 and the chassis used in the GEC 2040 series. The former uses a single transistor stage between the detector and the PFL200 luminance output pentode while the latter uses two transistor stages. In both chassis the signal is a.c. coupled to the control grid of the output pentode and d.c. restoration or clamping is thus required at this point. There are a fair number of components in the output pentode circuit, many of the resistors passing substantial currents. It is in this area therefore that faults causing impaired picture quality or restricting the brightness level are most likely to occur.

Representative Circuits

The circuit used in the GEC 2040 series is based on the PL802 output pentode and is typical of the circuits used in a number of other setmakers' chassis (see Fig. 1). The input coupling capacitor is C405 with D401 the d.c. restorer diode. Instead of being connected to chassis the anode of this diode is returned to the brightness control which thus sets the operating point of the stage. The beam limiter arrangement also affects the PL802's working bias, by altering the potential applied to the brightness control circuit should the c.r.t. beam current be excessive. Thus both the brightness control and the beam limiter determine the PL802's bias and in consequence its anode voltage, and since the coupling between the PL802 and the c.r.t. cathodes is d.c. they also control the beam current.

The cathode circuit consists of the chrominance subcarrier trap L403/C411, the partially decoupled (C412) resistor R411 (cathode compensation) and the blanking transistor Tr434. During picture information this transistor is biased into saturation by R414 and thus has negligible effect on the circuit. Negative-going line and field flyback pulses are applied to its base however, cutting it off during the flyback periods. This action also cuts off the pentode's anode current of course, its anode voltage rising to the h.t. rail voltage to black out the c.r.t. screen. D402 across the base-emitter junction of the transistor limits the negative pulse excursions to about 0.6V , protecting the transistor from excessive base-emitter voltage.

The anode load circuit consists of the shunt peaking coil L401, the load resistors R408 and R407 and at low frequencies R409 since at these frequencies C408 no longer effectively decouples R409. Series peaking is provided by L402 and the output is applied to the c.r.t. cathodes via a drive adjustment system which in this chassis consists of a plug and socket arrangement.

The luminance output pentode circuit used in the

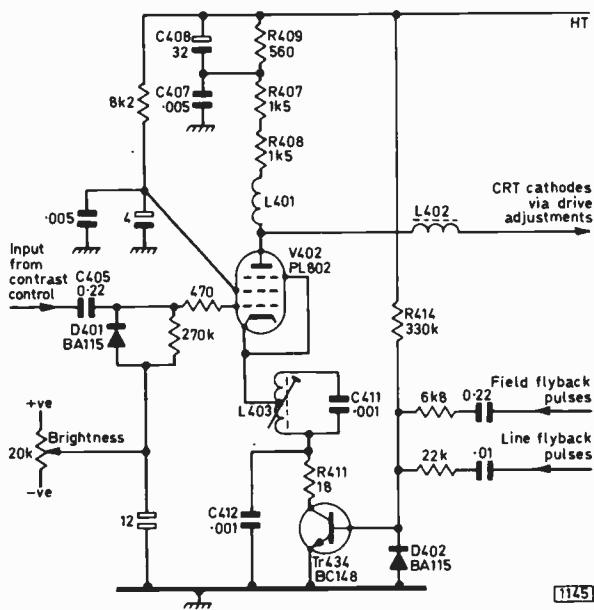

Fig. 1: Luminance output stage used in the GEC C2040 series of single-standard models.

single-standard version of the Philips G6 chassis is shown in Fig. 2. Once again the low frequencies are accentuated, R2137 and R2138 becoming part of the total load when the reactance of the shunt 50µF capacitor C2057 rises to a high level. In this chassis the chrominance subcarrier trap is included in the coupling between the transistor luminance preamplifier stage and the PFL200 luminance output pentode while the flyback blanking is carried out in the c.r.t. first anode circuit. There are three peaking coils, L2701 (shunt) and L2681 and L1521 (series).

The output is d.c. coupled to the red cathode via R1086 and to the green and blue cathodes via the

drive presets R1077 and R1080; C1034, C1031 and C1032 maintain the h.f. response. The circuit is based on the same principle as the d.c. contrast control circuit described in Part 2: the voltage at the junction R1081/R1082 is the same as the pentode's anode voltage at black level. In this way R1077 and R1080 can adjust the green and blue highlight drives with respect to the red drive without affecting the d.c. conditions of the circuit.

Instead of a simple diode d.c. restorer a transistor clamp circuit is used to restore the d.c. level following capacitive coupling to the pentode's control grid. The pentode's grid leak resistor R2110 and the emitter of the clamp transistor T2146 are returned to the slider of the brightness control which is connected across a negative supply. T2146 is without fixed forward bias and conducts only when a positive-going line sync pulse is applied to its base via C2002, C2043 and X2152. The coupling capacitor C2045 is then charged to the potential on C2001, establishing a fixed d.c. level on which the luminance signal applied to the control grid of the pentode stands. Thus irrespective of the luminance content during a line the signal at the beginning of the next line always starts off at the level set by the brightness control.

Fault Conditions

Since the transistor preamplifier stage or stages are a.c. coupled to the pentode output stage any defect in the preamplifiers causing complete signal loss will still leave a normally controllable white raster. Straight-forward voltage and resistance tests in such stages should quickly locate any defective component. Individual circuits vary quite widely however, so it could save a lot of time taking a look at the circuit diagram before making tests.

In the case of the GEC 2040 series for example the luminance delay line driver stage feeds the luminance emitter-follower and a.g.c. circuit from its collector and the decoder from its emitter. Thus complete loss

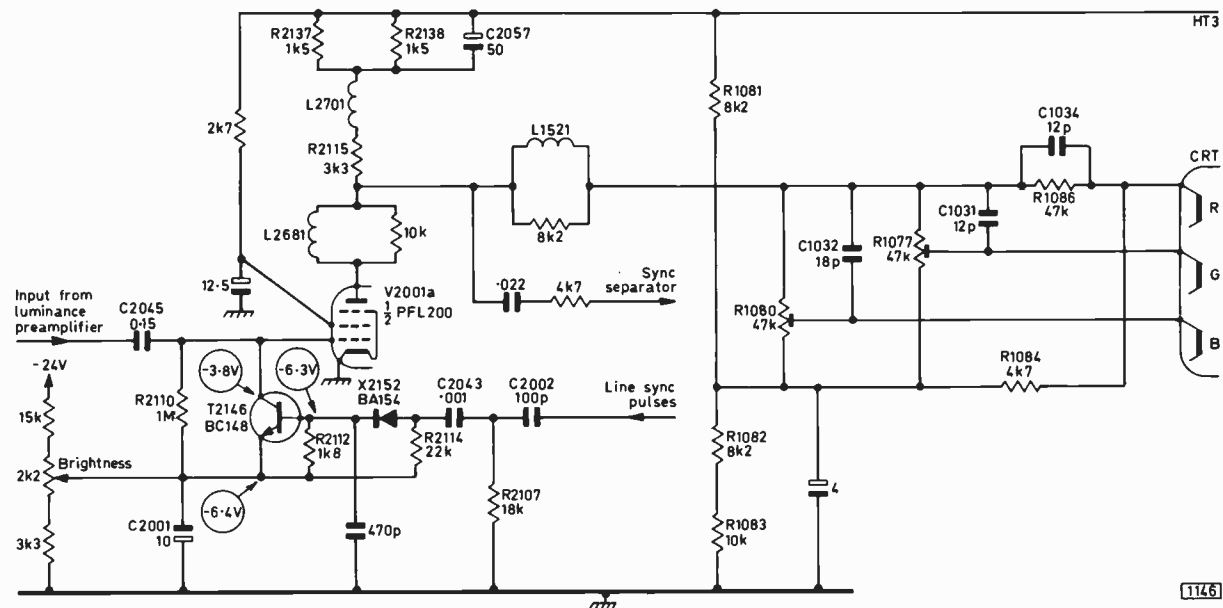

Fig. 2: Luminance output circuit used in the Philips G6 single-standard chassis.

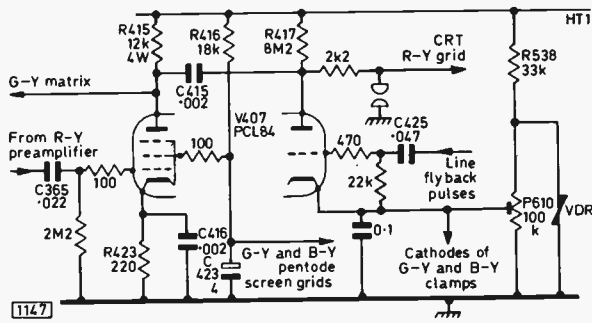

Fig. 3: R-Y colour-difference output stage, GEC C2040 series of receivers.

of luminance signal but colour-difference information remaining on the screen indicates that the delay line driver stage itself is still operative, which can be confirmed by tuning through a strong signal and noting the voltage change produced at the collector of the a.g.c. amplifier. This would confine the fault to the luminance emitter-follower stage therefore (no current in the output pentode would black out the screen).

Complete breakdown of a transistor luminance pre-amplifier stage is not common while cases of impaired definition etc. due to faulty preamplifier stages are rarer still. This is because the resistors rarely change value while the few capacitors involved are—except for the electrolytics necessary if a.c. coupling is used between stages—all of small size. When impaired h.f. response does develop it is most likely to be due to a misadjusted subcarrier trap or sound take-off coil, or more rarely to a dry-jointed or open-circuit decoupling capacitor. Impaired l.f. response would almost certainly be due to a dried up electrolytic coupling capacitor. One fairly common fault in this area however is a dry-joint on one of the luminance delay line connections: this causes a ringing effect on luminance signal outlines. Most luminance faults develop in the pentode output stage however, so let's concentrate on this.

As with a monochrome receiver poor h.f. response can be caused by an increase in the value of one or more of the anode load resistors since this will increase the loading effect of the stray shunt capacitance present. A reduction in the value of the anode load resistors, particularly where both shunt and series peaking coils are used, can also degrade the resolution however since the "lift" introduced by the coils will be altered. A misadjusted subcarrier trap in the cathode circuit can seriously affect the picture quality at the h.f. end, as can an open-circuit paper type cathode or screen grid decoupler, even if it is shunted by an electrolytic—such capacitors are in fact often connected across electrolytics because the self-inductance of these greatly detracts from their efficiency at h.f.

Variations in picture brightness level are commonly caused by a cathode blanking transistor not being on completely during the picture information. Lack of brightness can be caused by the pentode itself or by incorrect output pentode screen grid voltage—sometimes due to the decoupling electrolytic being leaky. A fault in the beam limiter circuit can also cause brightness faults.

Another fault that can be caused by the blanking circuit is striations on the left-hand side of the picture (but check the damping resistor across the line linearity

coil first). The transistor and diode are the usual faulty components in the case of blanking circuit faults.

Colour-difference Output Stage

With colour-difference drive we also need video circuits to feed the c.r.t. grids with the three colour-difference signals. Transistor preamplifier stages are required to raise the outputs from the synchronous detectors to levels suitable to drive the output pentode stages generally used. A typical circuit, returning to the chassis used in the GEC 2040 series receivers again, is shown in Fig. 3 (R-Y channel). The preamplifier is a.c. coupled to the control grid of the pentode which is in turn a.c. coupled to the c.r.t. grid. This means that the output to the c.r.t. must be clamped, and the triode section of the PCL84 is used for this purpose. It conducts when the line flyback pulses appear at its grid, setting the voltage on C415 at the beginning of each line to the potential set by P610. Since the bandwidth is less (1MHz) than that of the luminance output stage the circuit is much simpler. Some h.f. boost is provided by the partially decoupled (C416) cathode resistor R423.

The most common fault in this type of circuit is when R417 or its equivalent in one of the other channels changes value. This produces colour drifting. R415 or its equivalent in one of the other channels can also change value, or go open-circuit, resulting in incorrect colours. For both these faults the c.r.t. first anode circuits should also be checked. Brightness level change can be produced by incorrect clamp action due to a fault in the potential divider network which feeds the cathodes of the three clamp triodes, or by incorrect output pentode screen grid voltages since these are generally fed via a common resistor (R416 in Fig. 3 for example).

Solid-state Luminance Circuits

So much then for the hybrid video circuitry found in UK produced sets using colour-difference tube drive. To find a completely solid-state luminance channel in a set using colour-difference tube drive one has to look to imported models. For our final example, Fig. 4 shows the circuit used in the Sanyo Model CTP430. There are four stages, the first three being a.c. coupled, with additional transistors used to provide beam limiting and flyback blanking.

The first stage Q101 is an emitter-follower which drives the second stage Q303 and also, via a noise cancelling stage, the sync separator and decoder. The contrast control VR905 determines the amount of negative feedback in the emitter circuit of the second stage and is connected in the brightness control network. The signal is then fed via the impedance matching coil L302, the luminance delay line and the electrolytic coupler C306 to the driver stage Q304. Since the signal is d.c. coupled thereafter it must be clamped at the base of Q304. This action is performed by the back-to-back diodes D301 and D302 which are driven into conduction by positive-going line frequency pulses, thus returning C306 to the brightness control network so that at the beginning of each line it is charged to the potential across C307. Slight current drain through D301 and R316 maintains this level with negligible sag during the succeeding line period. The potential to which the base of Q304 is clamped is set by the two brightness controls—it is also affected by the contrast

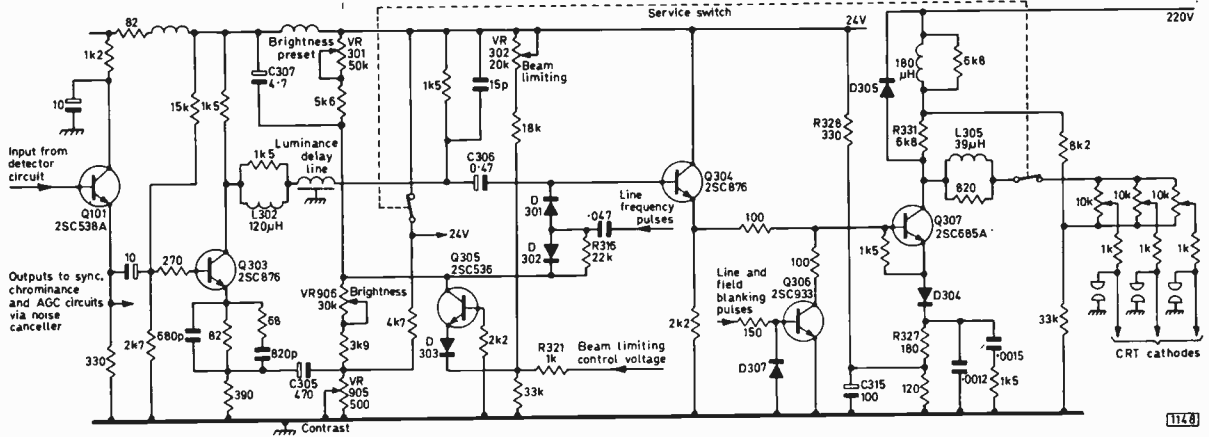

Fig. 4: Solid-state luminance channel used in the Sanyo Model CTP430.

control setting—and by the beam limiter. VR302 sets the level at which the beam limiting action occurs. If the beam current is excessive the negative potential applied via R321 and D303 to the emitter of Q305 results in this transistor conducting. In consequence its collector voltage falls, reducing the potential to which the base of Q304 is clamped. Since Q304 is an emitter-follower the drive to the luminance output transistor Q307 is also reduced, raising its collector voltage and thus driving the c.r.t. towards cut-off. This method of providing beam limiting action via the brightness control network is widely used in sets which employ colour-difference tube drive. In this chassis the sensing point from which the beam limiter control potential is obtained is at the earthy end of the e.h.t. winding on the line output transformer.

As in the case of solid-state monochrome video circuits the driver transistor is an emitter-follower providing a low-impedance input to the luminance output stage. Its emitter load resistor also develops the potential to forward bias the output transistor (Q307). Although Q307's collector is fed from the 220V rail, failure of the 24V rail or of the driver stage will result in the output transistor being cut off, blanking out the screen. Q307's collector load consists of R331 and the 180µH shunt peaking coil. D305 is included to protect the transistor against the effects of flashovers in the c.r.t. It is normally non-conductive since its cathode is returned to the h.t. rail: any positive surge as a result of a flashover from the c.r.t. cathode to the final anode will result in D305 conducting, limiting the flashover peak to the h.t. rail voltage.

D304 in the emitter circuit protects the output transistor's base-emitter junction against excessive reverse voltages: in the event of excessive reverse bias being applied to Q307 D304 will also be reverse biased and since its reverse resistance is much greater than that of the transistor's base-emitter junction most of the surge will be developed across the diode instead of the transistor junction, thus protecting the transistor. This is of importance in this particular circuit since flyback blanking is effected by Q306 which is connected across the input to Q307. Positive-going line and field flyback pulses drive Q306 into conduction, removing Q307's forward bias and blanking out the screen. Without protection however this action could result in excessive reverse bias across Q307's base-emitter junction, since the stabilising bleed current via

R328 will hold the voltage at the cathode of D304 at about 6V. Carrying out flyback blanking in this way has the advantage that the output transistor's dissipation is reduced.

Frequency response compensation is introduced since R327 is only partially decoupled.

Faults in Solid-state Circuits

L.F. attenuation in this circuit could be caused by loss of capacitance in any of the electrolytics. This would also reduce the gain and, in the case of C305, restrict the range of the contrast control.

Impaired definition (h.f. response) could be caused by an open-circuit delay line impedance matching coil (L302), an open-circuit output stage peaking coil or an open-circuit emitter decoupler in the emitter circuits of Q303 or Q307.

On rare occasions in receivers of various makes it has been known for the output transistor to become defective, causing reduced bandwidth as a result of reduced cut-off frequency or a shading effect as a result of charge storage phenomena.

With the possible exception of open-circuit or shorted-turn peaking coils however poor definition in all colour sets is usually the result of either poor focus, tuner or i.f. circuit drift, mismatch between them following replacement of one or the other without adjusting the coupling, a poor aerial or the use of an aerial of the wrong type.

The more common faults associated with all types of solid-state luminance circuit are: (1) Complete signal loss due to an open-circuit resistor, a printed board disconnection or a faulty transistor. (2) Weak results, especially at l.f., due to a reduced value electrolytic coupling capacitor. (3) Signal cramping at one extreme or the other due to a resistor value change or leaky electrolytic coupler increasing or decreasing the normal forward bias applied to a stage. (4) Restricted brightness control range, often making it impossible either to fully black out the picture or obtain peak white.

Paralleling an equivalent across an electrolytic capacitor suspected of being of reduced value is the easiest way to check it. It is most important however, especially in the case of base coupling or emitter decoupling electrolytics, to lightly solder the equivalent in place with the set switched off and not to stab it across the suspect with the set still working.

the

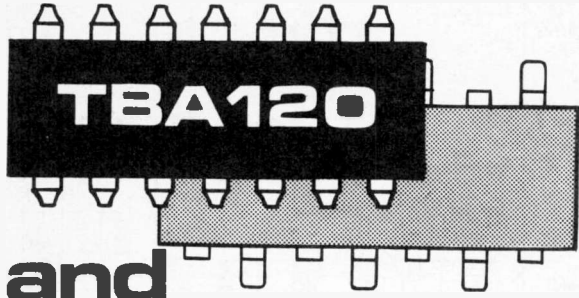

and

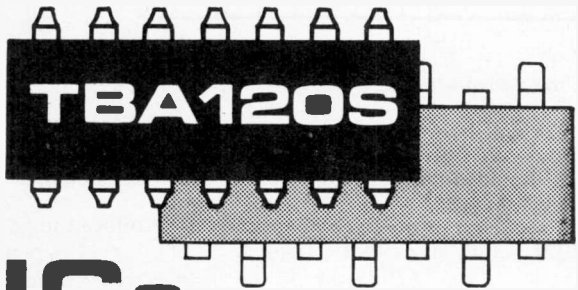

ICs

Phosphor

THE ITT TBA120 and TBA120S are now widely used as the 6MHz intercarrier sound section of television receivers, both monochrome and colour. The later TBA120S is pin compatible with the TBA120 but not necessarily interchangeable, as we shall see. Both have a d.c. volume control facility but the method of control differs.

The i.f. amplifier/limiter section consists of a series of differential amplifiers. There are six in the TBA120, while in the TBA120S there are eight with constant-current source emitter coupling. The differential amplifier configuration is ideally suited to use in integrated circuits because of the close matching which integration makes possible between the two halves of the pair. Other names for this basic circuit are current mirror and long-tailed pair, which may evoke memories of wartime radar sets.

The discriminator arrangement used in integrated circuits consists of a coincidence detector. These particular i.c.s use a symmetrical version requiring a balanced tank circuit—generally referred to as the quadrature coil—to establish the necessary phase relationships. Once again the basic building block consists of the differential pair, but used twice over in an inverted family tree pattern as shown in simplified form in Fig. 1.

Tr1 and Tr2 behave as current sources for Tr3/Tr4 and Tr5/Tr6 respectively. They themselves are fed from the constant-current source in their common emitter circuit. One point may need clarifying here: the current passed by these sources is constant with respect to the load or voltage presented to them (within limits of course) but can be made to vary with time, as is the case for Tr1–Tr6. It is possible therefore to talk of a constant a.c. source without this being a contradiction in terms—after all the domestic supply is a source of

a constant alternating voltage which varies with time but not the load, and this terminology is accepted.

The sum of the collector currents of Tr1 and Tr2 is made constant with respect to time as well as voltage by the source which feeds their emitters. Thus if Tr1 is switched fully on it takes all the current and Tr2 takes none: V_{signal} is limited to a value such that this happens, Tr1 and Tr2 being switched on and off alternately at instants determined by the instantaneous frequency of the i.f. signal.

The reference voltage is also derived from the limited i.f. signal, but a tuned circuit is interposed so that $V_{\text{reference}}$ is more like a constant-size sinewave, though still bearing f.m. since the Q of the tuned circuit is not high enough to eliminate the f.m. sidebands. The tuned circuit is energised from the limiter circuits via two small capacitors which have considerable reactance compared to the dynamic resistance of the tank circuit. Thus at resonance the voltage across the tuned circuit will be 90° out of phase with the driving voltage—this state of affairs gives rise to the term quadrature coil. We will first examine the behaviour of the circuit at resonance and then go on to see what happens when the frequency varies.

The quadrature circuit is tuned—by adjusting the coil's core—so that there is a 90° phase shift at the unmodulated i.f. centre frequency—6MHz in the case of television sound, 10.7MHz in the case of v.h.f./f.m. radio sound. Idealised waveforms are shown in Fig. 2 in full lines. Currents I_1 and I_2 (the collector currents of Tr1 and Tr2) switch on and off alternately at the instantaneous i.f. $V_{\text{reference}}$ is in quadrature with this. Thus I_3 (Tr3 collector current) can flow only when Tr1 is on and $V_{\text{reference}}$ is positive. The currents flowing in Tr4, Tr5 and Tr6 are determined in the same way—with the convention we have adopted $V_{\text{reference}}$ must be negative-going in order to turn on Tr4 and Tr5. As a result of all this V_{out} will be high when neither I_3 nor I_5 flows and low if either of these currents flows. Thus at resonance the output voltage waveform will approximate to a 50:50 squarewave at twice the carrier

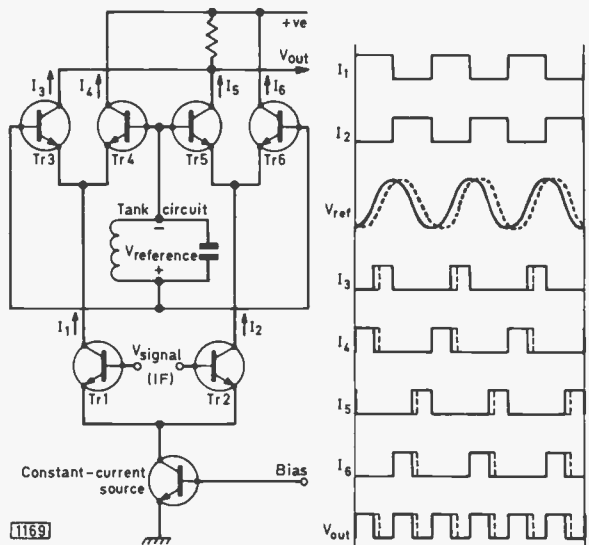

Fig. 1 (left): Basic symmetrical coincidence detector circuit.

Fig. 2 (right): Waveforms for circuit shown in Fig. 1.

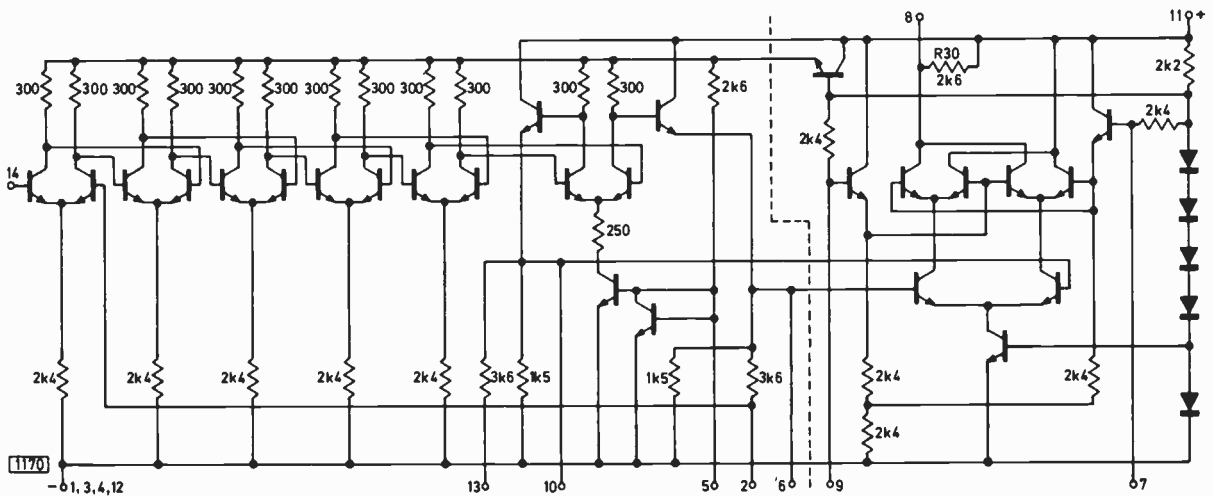

Fig. 3: Internal circuit of the TBA120.

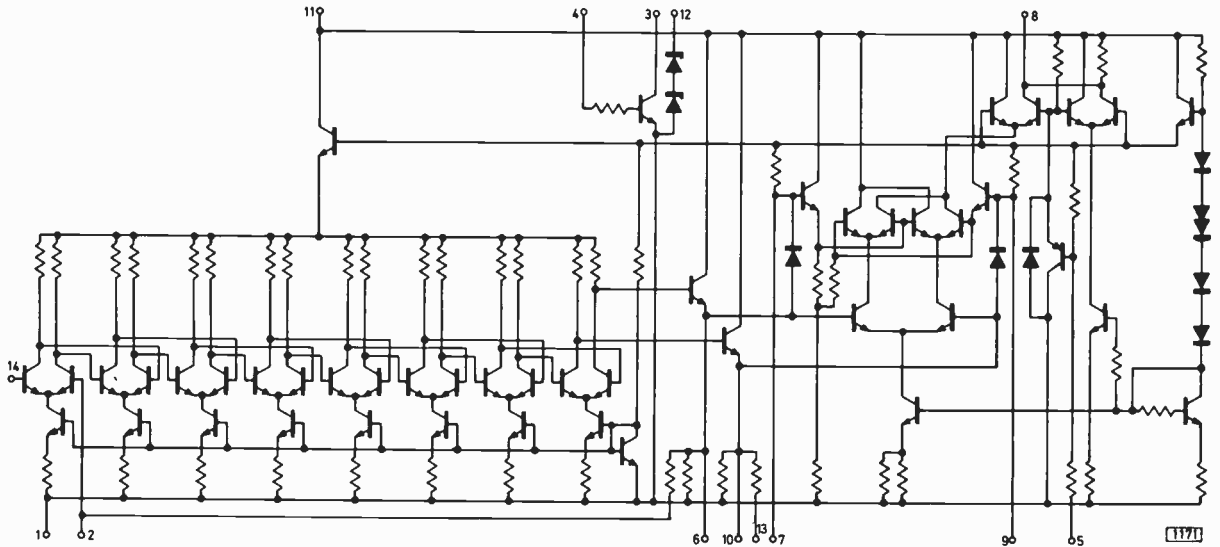

Fig. 4: Internal circuit of the TBA120S.

frequency.

When the i.f. deviates from the resonant frequency of the tank circuit the latter will no longer look resistive: it will have capacitive reactance above resonance and inductive reactance below. Accordingly, the phase shift will be less or more than 90° . A shift to rather more than 90° is shown by the dotted waveform in Fig. 2: by following through the waveforms down to V_{out} we can see that in this case the output stays high for a longer period than it stays low. When the phase shift is to less than 90° the converse situation occurs.

By filtering the output the component at twice the carrier frequency is smoothed out, leaving just the variations due to the modulation. With perfect symmetry there will be no carrier frequency component at all, easing the maintenance of stability around the i.c. despite the 60dB gain at i.f. prior to the discriminator section.

For accurate demodulation the phase shift must be proportional to frequency over the deviation range. Both the LC ratio and the Q of the quadrature coil are

critical. For TV sound both the TBA120 and TBA120S are designed to operate with a loaded Q of 45. For f.m. radio a lower Q (and therefore output) can be used. For really low distortion a coupled-pair quadrature circuit is recommended, but this makes alignment difficult. In any event, since the deviation is small compared to the centre frequency only a volt or so of output is obtainable.

In the absence of a signal the value of V_{out} is equal to the mean when the i.c. is being fed with a signal at the resonant frequency of the tank circuit. This can be used as an alignment aid, by tuning the coil until the same voltage is obtained as when there is no carrier input. This is easy in the case of television where the carrier frequency is accurately defined (6MHz is the difference between the sound and vision carriers) but rather more difficult in the case of f.m. radio since 10.7MHz is only a nominal figure. Also the correct tuning point in the case of television coincides with minimum vision-on-sound (caption buzz) and maximum audio.

Differences

There is only one difference between the discriminator circuits used in the two i.c.s, but this may prevent interchangeability without modification. In the TBA120S two internal reverse-biased diodes are used as the tank circuit feed capacitors—the external 56pF feed capacitors shown in Fig. 5 between pins 6 and 7 and 9 and 10 are not required.

Volume control in the case of the TBA120 is achieved by reducing the current flowing in the final differential amplifier pair, which is used as a limiter and unlike the preceding five stages (see Fig. 3) has a constant emitter current source. Variation of the current alters the amplitude of the limited signal fed to the coincidence detector and hence the audio output. At low levels the switching action of the coincidence detector becomes rather blurred and it behaves more like a four-quadrant analogue multiplier, resulting in some loss of linearity. Also, since the gain control precedes the discriminator any noise generated in the discriminator circuit will not

be attenuated as the gain control setting is reduced. Noise will thus become noticeable at low levels.

The circuit used in the TBA120S (see Fig. 4) is entirely different. The output from the discriminator is taken to the emitters of yet another differential pair which operate in the cascode mode. The d.c. volume control varies the current flowing in the output side of the pair (the top half of the cascode). As a result of the current mirroring property the rejected current at low volume settings flows through the other half of the pair. An amount of d.c. corresponding to the d.c. component of the audio signal is passed through the output side load in order to retain the alignment facility previously mentioned, or the a.f.c. ability, whatever the volume control setting. This arrangement gives a better gain/volume control rotation characteristic in addition to the sought after reduction in distortion and noise at low volume.

The TBA120S is graded into four categories according to the value of d.c. volume control resistance required to give a gain reduction of 30dB. In category I a 1.9–2.2kΩ volume control is required from pin 5 to chassis, in category II a 2.1–2.5kΩ control, in category III a 2.4–2.9kΩ control and in category IV a 2.8–3.3kΩ control.

The TBA120S also incorporates an extra npn transistor and a 12V zener diode whose anode is connected to the emitter of the transistor. The makers suggest using the transistor for a d.c. tone control and the zener for stabilising the supply to this and any further circuits (within its limit of 15mA).

Use

Fig. 5 shows the peripheral circuit suggested by the makers for use with the TBA120. The value of Cs depends on the amount of supply voltage smoothing required. The de-emphasis time-constant is determined by the value of the capacitor between output pin 8 and pin 11 along with the resistor between these pins within the i.c. Miniature 7×7mm Neosid filters are suggested for the coil assemblies, with 12 turns of 0.1mm diameter enamelled copper wire for L1 (core F10B) and 4 turns for L2 (core F2). Alternatively a standard 6MHz ceramic filter can be used for the input as shown in Fig. 6. The peripheral circuit suggested by the makers for the TBA120S is shown in Fig. 7.

The TBA120 and TBA120S are not the latest in i.f. amplifier/limiter/discriminator/d.c. volume control i.c.s, but have been around long enough to have proved themselves to be reliable components. There are now some second sources, e.g. the Texas SN76660 which can be used in place of the TBA120. Versions with an A suffix have dual-in-line pins, those with a B suffix quad-in-line pins.

With a coupled-pair quadrature circuit the TBA120S will give adequate linearity for hi-fi mono f.m. receiver constructors, with the onset of limiting at a maximum of 60μV input. With an f.e.t. preamplifier and a ceramic 6MHz filter this i.c. can form the basis of a high-quality TV sound pick-off adaptor, but in common with all i.c.s for i.f. amplification and limiting there is an upper and lower limit to the input for satisfactory a.m. rejection. In the case of the TBA120 100mV should not be exceeded while for the TBA120S with its greater i.f. gain no more than 20mV should be applied to the input or caption buzz will be noticed.

Finally, for minimum external component count the TBA120S is hard to beat.

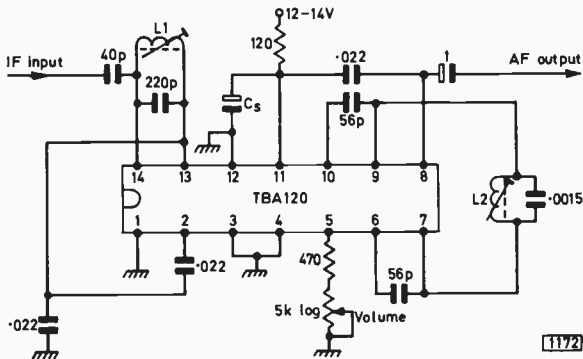

1172

Fig. 5: Peripheral circuit suggested by the makers for use with the TBA120.

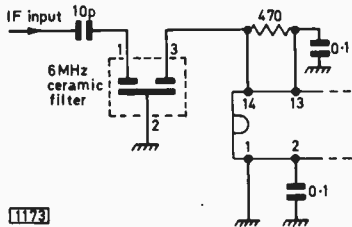
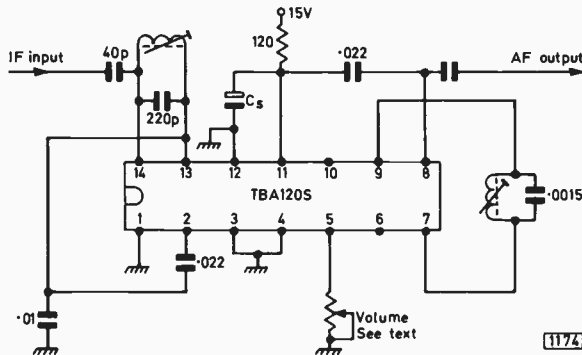

Fig. 6: Method of using a standard 6MHz ceramic filter for the input.

1173



1174

Fig. 7: Peripheral circuit suggested by the makers for use with the TBA120S.

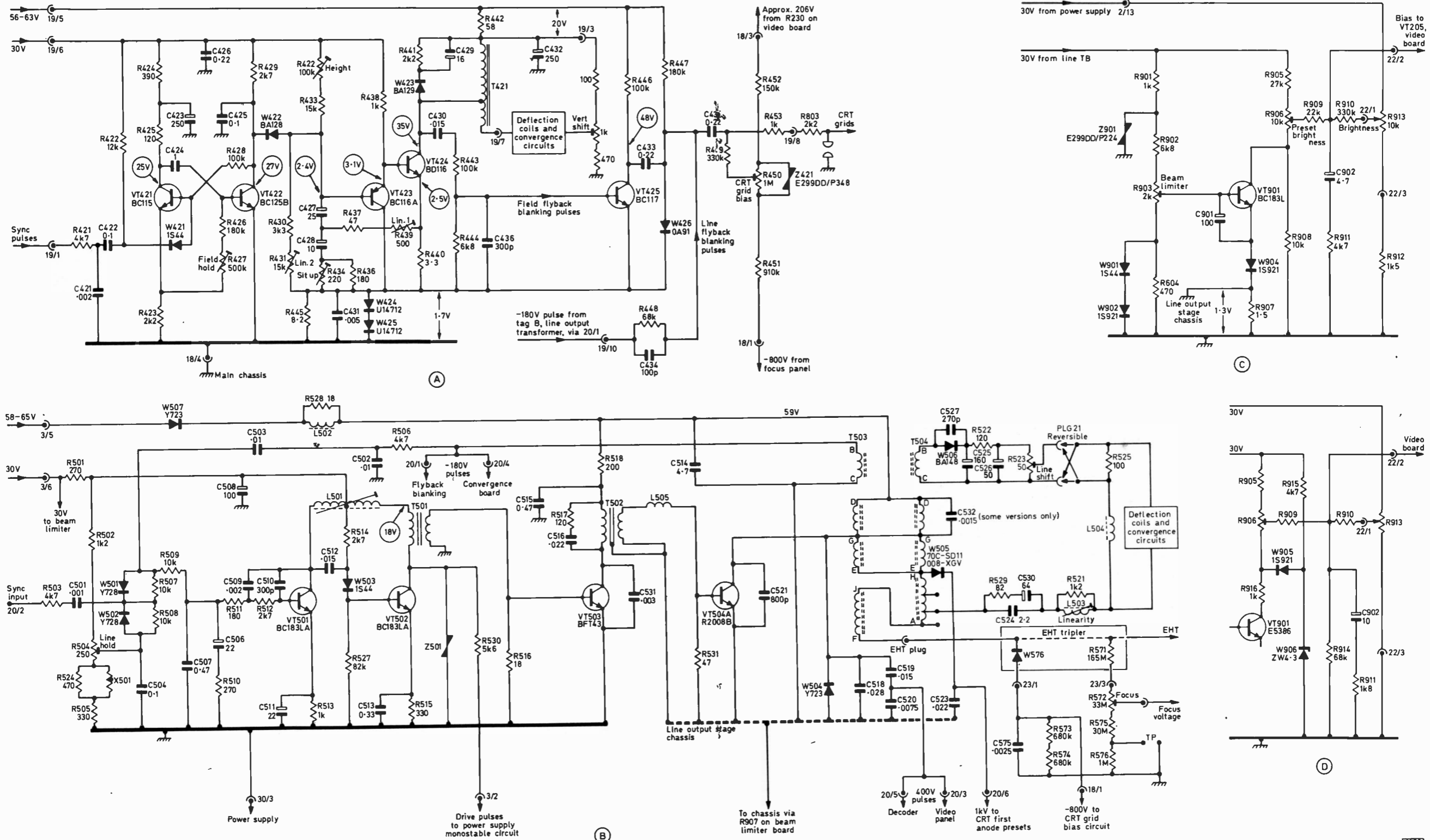

Fig. 1: Timebase, beam limiter and c.r.t. blanking and grid bias circuits. (a) The field timebase. In earlier production R434 is 200Ω with R435 (10Ω) connected from the junction of R434/R436 to the junction R445/C431, C430 is 0.022μF and X421 (VA1034) is connected across R440. Note that the voltage shown at VT424 collector applies at 60V h.t. (b) Line timebase circuit. In earlier production C506 and C511 are 25μF, R510, 120Ω, VT503 type E1222 and L505/R531 are omitted. In the 3000 chassis R572 and R573 are 25MΩ and the e.h.t. is 24kV instead of 25.5kV: in consequence the wiring between T503 and T504 is slightly different, J of T503 being linked to tags E instead of to tag A of T504. In later production 3500 chassis J of T503 is connected to tag H of T504 instead. The transformers are coded to indicate the correct connections. (c) Beam limiter circuit. (d) Modifications to the beam limiter.

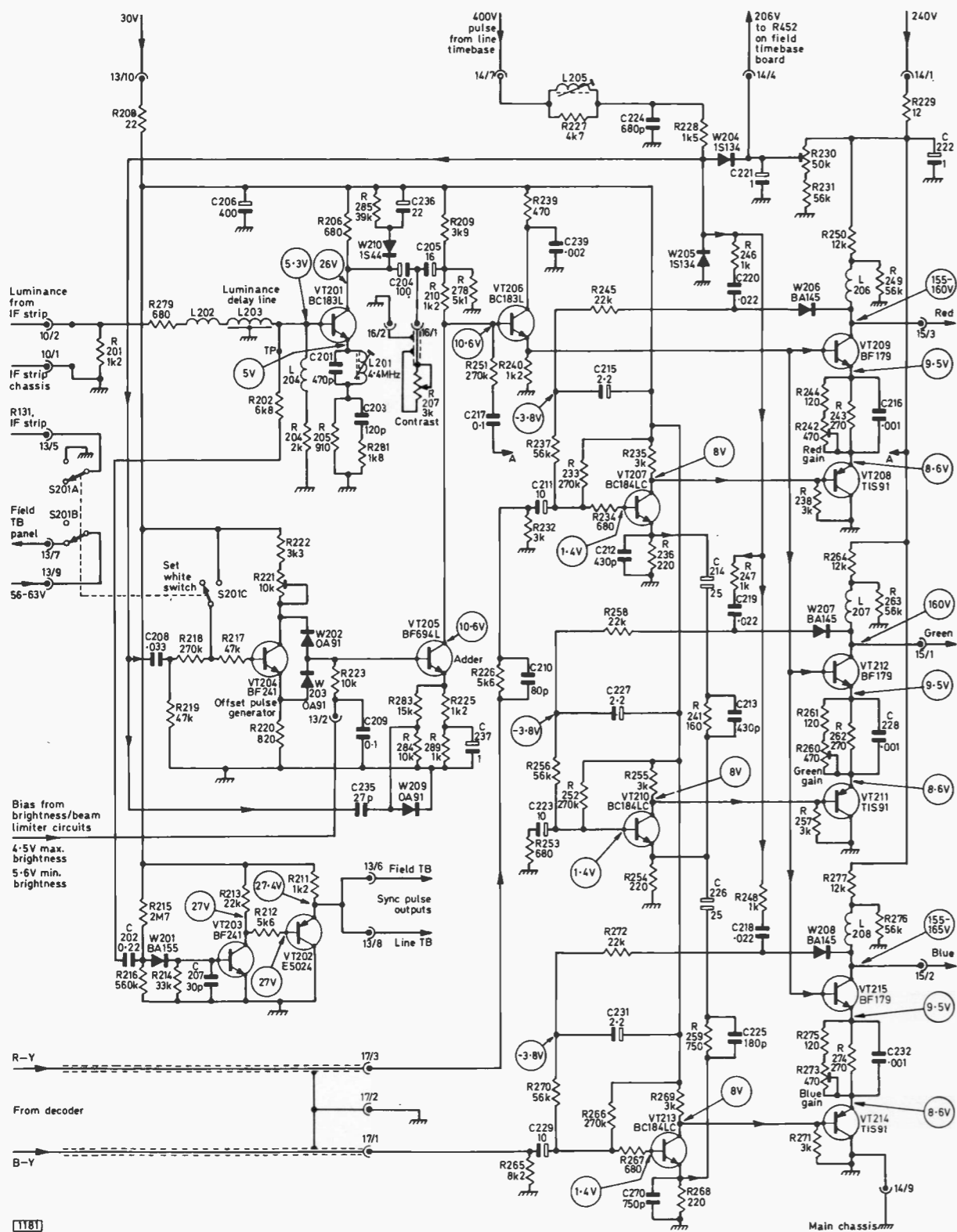

Fig. 2: Circuit of the video board. In earlier production R288 (1k Ω) is connected across L201, C239 omitted, VT203 and VT204 are type BF224 and VT205 type BF224L. C235 is 18pF, R242/R260/R273 500 Ω , C215/C227/C231 2 μ F.

THORN 3000/3500 CHASSIS

common faults

PAUL E. SOANES

THE Thorn 3000 single-standard colour chassis was introduced in 1969 and is probably the most frequently encountered chassis in colour receivers. It is used in sets in the Ferguson, Ultra, Marconiphone, HMV, DER, Baird, Alba and other ranges. The subsequent 3500 chassis, which differs mainly in its convergence circuitry and the addition of pincushion distortion correction, is used in 26in. and some 22in. models. The unique chopper stabilised power supply was covered in the September 1974 issue, with additional comments in the Letters page in the November 1974 issue. In this article we shall deal with faults we have come across on the other boards.

Line Timebase Panel

Apart from the power supply module, the line timebase (Fig. 1b) is the most troublesome part of the set. Some of the faults here will blow the h.t. fuse F603 on the power supply panel. Early models used a two-transistor (VT504 and VT505) line output stage while later models use a single-transistor (VT504A) line output stage. If the line output transistor(s) go short-circuit the fuse will blow and frequently R907 (1.5 Ω) which forms the line output stage earth return and is mounted on the beam limiter board will go open-circuit. Other components which will blow the fuse are C514 (4.7 μ F) which decouples the supply to the line output stage going short-circuit, C523 (0.022 μ F) which is the c.r.t. first anode supply reservoir capacitor going short-circuit, the efficiency diode W504 going short-circuit, or either the driver transistor VT503 or the capacitor (C531) across it shorting. If the e.h.t. transformer (T503) is defective the fuse will sometimes blow. Common causes of no e.h.t. are the driver or output transistors, the efficiency diode, R907 and C514.

No picture but e.h.t. present will be the symptom when C523 is short-circuit. Inevitably the first anode supply rectifier W505 will also be damaged and this will emit an unpleasant smell.

Lack of Width

R528 (18 Ω) will be damaged if L502 goes open-circuit and the result will be lack of width: it will also be damaged if C514 shorts resulting in no e.h.t. Note that C514 is a special type. Disturbances when the set has warmed up can be caused by C514. R528 can be badly discoloured and sometimes open-circuit without any other fault being present.

Lack of width can also be caused by the core falling out of the line shift circuit a.c. blocking coil L504. This is easily overlooked if you are not familiar with the chassis.

Poor Focus

Poor focus with the control at its limit is generally caused by the e.h.t. tripler—the internal 165M Ω resistor which feeds the focus circuit goes high-resistance. The tray can be damaged if C575 (2,500pF) on the focus panel is leaky or the tray's earth return lead is not making proper contact.

Line Hold Troubles

Drift or weak line hold is a fairly common fault, generally due to one or other of the two electrolytics C506 (25 μ F) in the flywheel filter circuit or C511 (also 25 μ F) which decouples the emitter of the reactance transistor VT501. As with most line generator circuits the flywheel sync discriminator diodes (W501, W502) should not be overlooked. R524 can also cause these faults and in one case we found that the thermistor X501 was defective, causing line drift and the need to frequently adjust the line hold control. In stubborn cases of line drift try adding a 220 Ω resistor in series with X501, also check VT503.

To adjust the line hold control from cold connect the positive lead of a meter switched to its 10V d.c. range to the slider of R504 and the negative lead to chassis, short the flywheel test point (just below the field output transformer) to chassis, adjust R504 for a reading of 6.2V and then adjust L501 for a stationary picture. Finally remove the short-circuit. Note that the reading 6.2V applies only when the receiver has just been switched on from cold.

If the verticals are bent it is worth checking the two electrolytics C525 (160 μ F) and C526 (50 μ F) in the line shift circuit.

Jitter on the line can be caused by the line driver transistor VT503 or by dry-joints on or around the driver transformer T502.

In the two-transistor line output stage the usual flyback pulse equalising network is connected across the transistors. If the lower transistor is faulty the resistor (R526, 47 Ω) connected from the two transistors to the equalising capacitors will be damaged.

No Colour, Excessive Brightness

When C520 (7,500pF) goes short-circuit there will be no 400V pulse feed to the video and decoder boards. The symptoms are no colour and excessive brightness.

Field Timebase

A multivibrator consisting of VT421 and VT422 comprises the field oscillator. C423 (250 μ F) which

decouples the supply to VT421 has a habit of being intermittent with the result that lock is lost and no amount of hold control adjustment will restore it.

A number of faults are common in the field driver stage. Failure of the driver transistor VT423 will give no scan of course. Diode W422 can give satisfactory readings but nevertheless be the cause of false field lock and lack of height. The sit-up control R434 usually has a rough spot somewhere after a period of use and the effect is that the bottom of the picture rises and falls while horizontal lines may appear across the screen. The control must be replaced. Poor linearity is usually due to one or other of the field charging capacitors C427 (25 μ F) or C428 (10 μ F) being leaky, or alternatively the output transistor VT424.

If C432 (250 μ F) which decouples the supply to the output stage goes short-circuit the field will collapse and the associated dropper resistor R422 will probably be damaged and need replacement. The output transistor itself is reliable, though it can cause poor linearity. Cramping or foldover at the top can be caused by W423 or C429. Bottom cramping can be produced by C705 (400 μ F) on the convergence panel.

Blanking Circuit

We have experienced both the transistor (VT425) and diode (W426) in the blanking circuit go open-circuit and short-circuit. If the c.r.t. grid bias preset R450 requires adjustment this should be done as follows: turn the beam switches off and operate the set-white switch, connect a meter switched to the 100V range between one of the c.r.t. grids (pin 3, 7 or 12) and chassis (positive to chassis, negative to the grid) and adjust R450 for a reading of $-20V$.

Audio Stages

The audio circuits are d.c. coupled, the only unusual aspect being the loudspeaker impedance which is 80 Ω . Low output can be caused by the output coupling capacitor C409 (100 μ F) or C407 (32 μ F) which decouples the emitter of the first stage being faulty. C405 (250 μ F) which decouples the supply to the audio circuits can go short-circuit so that there is no sound. C401 (4.7 μ F) which decouples the bias applied to the base of the first stage can leak, producing distorted sound and overheating in the upper output transistor VT403. In the event of intermittent sound check for dry-joints or broken connections around the output transistors. Distorted sound can often be due to the loudspeaker.

IF Panel

The i.f. panel gives little trouble. Probably the most common faults are due to C179 (10 μ F) which decouples the a.g.c. line. When it goes open-circuit the symptom present is lines across the screen, similar to severe sound-on-vision. This trouble is most frequently experienced on earlier models. When C179 goes short-circuit there is no vision and weak or no sound. Note that when the raster is not synchronised foldover will be seen at the bottom. C177 (30 μ F) which decouples the supply to the first i.f. stage can be responsible for intermittent vision.

Low and distorted sound are often due to one or other of C158 and C159 (both 180 μ F) which tune the

secondary of the ratio detector transformer. They usually go open-circuit, but sometimes intermittent. The 4.7 μ F electrolytic (C163) in the ratio detector circuit will produce distortion when open-circuit.

No colour can be due to the first chrominance transistor (VT110) which is on the i.f. board being defective, also to its output coupling capacitor C175 (0.01 μ F).

Video Panel

Faults on the video panel (see Fig. 2) are frequently due to defective electrolytics.

Favourites are the 2.2 μ F capacitors C215, C227 and C231 which are in the clamp circuits, developing the bias applied to the colour-difference amplifiers. They either go leaky or short-circuit and the result is the predominance of the colour produced by the channel of which they form part—for example when C215 is leaky there is excessive red. The same fault can be caused by the clamp diodes (W206, W207 or W208) going short-circuit. When C223 (10 μ F) which decouples the base of the green colour-difference amplifier goes open-circuit the picture is shaded purple and green—at first glance the effect can be mistaken for a purity error.

The clamp pulse amplitude control R230 should be set for 160V at the c.r.t. green cathode. If it is not possible to obtain this reading it is likely that C221 (1 μ F) is open-circuit.

The set porch bias control R221 sets the bias on the luminance driver transistor VT206: correct setting is when there is 10.7V at the base of VT206—a convenient point to take this reading is on a jumper lead behind VT202. When making this adjustment operate the set white switch and turn the beam switches off. If the correct reading cannot be obtained the two diodes W202 and W203 should be checked, also VT204 and VT205. Brightness troubles can also be caused by C519 and C520 from which the clamping and luminance offset pulses are derived in the line output stage, C902 (beam limiter board) which decouples the brightness and preset brightness controls, and lack of c.r.t. first anode voltage. If R221 is defective the symptom can be no luminance.

If C205 is leaky the base voltage of the luminance emitter-follower will fall: there will still be luminance but no colour due to the action of the clamps being affected.

If there is no luminance and the contrast control does not operate check C204 which can go open-circuit. Failure of the RGB output transistors VT209, VT212 and VT215 is often due to a flashover in the c.r.t. The colour-difference emitter-followers (VT208, VT211 and VT214) may also be damaged by the flashover. The thick-film load resistor arrangement is quite reliable, which is just as well since it would be rather an expensive way of replacing one resistor.

Decoder

As with the i.f. strip, the decoder is very reliable. The diodes around the burst channel fail however. A couple of electrolytics can give the no colour symptom, C330 (4.7 μ F) which is the reservoir for the chrominance turn-on bias and C325 (1 μ F) which decouples the supply to the ident amplifier. The arrangement used

CCTV

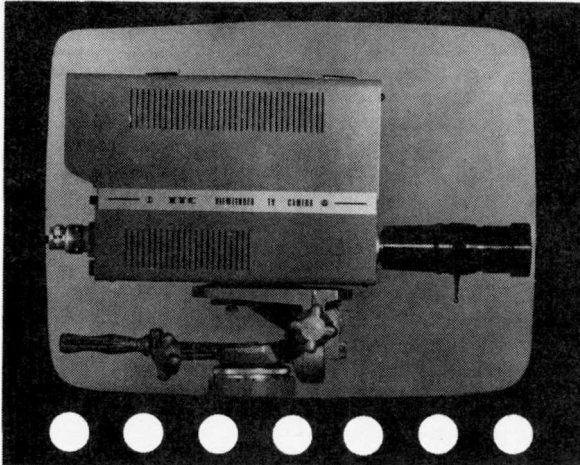

PART 13

Peter Graves

We have referred so far to resolution as the ability to discern fine detail. No attempt has been made to provide a quantitative measurement that would enable comparisons to be made between different equipments, or the performance of a single equipment to be measured at different stages of its setting up or during its life. Generally we are interested in the maximum resolution, which is determined by assessing the finest structure of alternate black and white lines that can be discerned. To be more specific, there are two resolution measurements associated with CCTV cameras (the same considerations also apply to monitors and domestic receivers), horizontal and vertical resolution.

Horizontal resolution is the amount of detail that can be seen across the picture. If we consider only one line, horizontal resolution is basically the maximum number of alternate black and white dots that the camera can make out. Vertical resolution is the amount of detail that can be seen looking up and down the picture—the maximum number of horizontal lines that can be resolved. Vertical resolution (for a normal, horizontally scanned camera) is normally less than the horizontal resolution.

Measurement Systems

Both the film and TV industry measure resolution in terms of lines although the units used differ. For film use resolution (in either direction) is measured in lines per millimetre, but only a black line and not the inter-

mediate white space is counted as a line. In TV practice resolution is measured in lines per active picture height (that is we take into account only the part of the picture that conveys information, ignoring the lines lost during the blanking interval), and both the black line and the intermediate white space count as lines. It follows that for this purpose the black line and white space are the same width.

To clarify this, consider a camera focused on a test card mounted at a suitable distance from the lens, so that the card just fills the monitor's picture area. If we talk of the camera having a resolution of 500 lines (ignoring the direction for the time being) we mean that the maximum resolution in the direction specified is 500 lines per active picture height. That is, 500 horizontal lines (black plus white) would just fit into the height of the picture. Lines of a finer structure (say 550 lines) would not be resolved, appearing as a grey blur instead of as separate lines. In practice the terms maximum resolution and per picture height are dropped, the resolution being referred to as just so many lines. It follows of course that coarser structures (say 450 or 100 lines) will be seen as separate lines.

Horizontal Resolution

The maximum horizontal resolution (i.e. along a line) depends on the rate at which the various signal currents and voltages throughout the camera and (if the resolution is being measured by eye from a monitor image) the system to which it is connected can change. Thus the maximum horizontal resolution is determined by the highest frequency that can be passed by the system or, in other words, by the bandwidth of the system. The vidicon's output may include finer detail but unless the amplifier and vidicon are matched together and the rest of the system possesses an adequate bandwidth the final picture will not contain this information. For this reason test monitors (and for that matter oscilloscopes) should be of superior quality to the camera(s) under test.

The relationship between the fineness of the line structure that can be seen and the bandwidth is indicated by the gratings on the familiar broadcast test chart. These specify the maximum resolution of the overall system (studio, transmitter, transmitting path and receiver) not in lines per picture height but in MHz of bandwidth. Strictly the resolution of the eye should

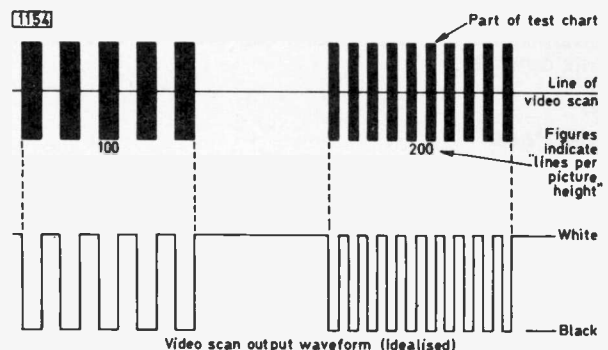

Fig. 1: Part of a test chart showing blocks of resolution bars and the idealised output waveform from a camera scanning them.

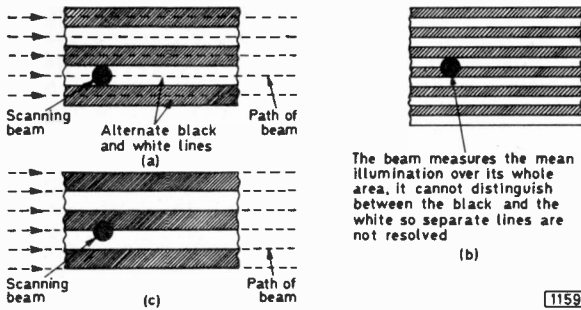

Fig. 2: Scanning a horizontal line structure—

- (a) Scanning beam exactly aligned with the white lines
- (b) A finer line structure cannot be resolved
- (c) The line structure of (a) cannot be resolved if the beam is not aligned with the white lines.

also be taken into account, but except in cases of very defective sight the eye far out-performs the TV channel! In a 625-line system there are approximately 75–80 lines for every megahertz of bandwidth. Thus a CCTV camera with a bandwidth of 6MHz is theoretically capable of a maximum resolution (in the horizontal direction) of about 500 lines.

Vertical Resolution

Vertical resolution—the amount of detail that can be seen in the vertical direction—is measured by determining the maximum number of horizontal lines that can be resolved. However, unlike horizontal resolution, its value is inherently limited by the number of active lines in the picture.

Let's consider a scanning system with a scanning beam of finite size, the camera being focused on a horizontal line structure so that the beam traverses successive lines as shown in Fig. 2(a). This is the maximum vertical resolution situation. Suppose, to clarify this, that the width of the lines is less than the diameter of the scanning beam (Fig. 2(b)). When the pattern is scanned the beam will always be part on, part off any given line. The scanning beam can only respond to the mean illumination of the area on which it lands, it cannot discern detail existing in that area. Thus, the beam interprets the line junctions it lands on as being some shade of grey and the separate line structure will not be seen.

Returning now to Fig 2(a), it has been shown that this represents the maximum resolution case, leading us to believe that the maximum vertical resolution of a TV camera is equal to the number of active lines in the picture. For a standard 625-line system about 40 lines are lost during the vertical blanking periods leaving about 585 active lines, implying a maximum vertical resolution of 585 lines per active picture height.

Practical Limitations

In practice, it is found that the vertical resolution is always less than this. First because to achieve the theoretical maximum value the scanning beam must fall exactly onto the lines being scanned, as in Fig. 2(a). Any displacement, however slight, due to inaccurate scans or poor setting up will result in loss of resolution.

Take an extreme case, where the lines are displaced by half a line width (Fig. 2(c)). Although the number of lines per active picture height remains constant the scanning beam can no longer resolve them as the beam is always half on, half off each line giving a uniform, mid-grey, output signal with no trace of the original line structure.

Secondly, it has been assumed that there is no gap existing between successive scans. In practice this is not so in order to prevent the sideways leakage of electric charge between the differently illuminated portions of the target layer during the operation of the camera tube.

Kell Factor

Practical measurements show that the usable maximum resolution is generally about 70% of the theoretical value, that is:

$$\text{Actual value} = 0.7 \times \text{theoretical value.}$$

The factor of 0.7 (this is a typical value in common use, it can vary in some applications from about 0.4 to about 0.9) is known as the approximation of utilisation or simply as the Kell factor (named after an early TV experimenter). For a given scanning system this enables us to determine the maximum vertical resolution that we can expect. It must be stressed that it is an experimental value and is known casually as a fiddle factor!

To show its use let's look at our 625-line system with its 585 active lines. We want to know how much vertical resolution the system is capable of providing. Maximum resolution = theoretical resolution (number of active lines) \times Kell factor = 585×0.7 or about 410 lines per active picture height. Compare this figure with a typical maximum horizontal resolution of 600 lines—limited by the amplifier bandwidth, not the number of lines. If we wanted more vertical resolution while retaining the same horizontal resolution, it would be necessary to increase the number of active lines in the picture. For instance, the French 819-line system with about 737 active lines will have a maximum practical resolution of about 737×0.7 or about 516 lines.

If for a specific application the vertical resolution is more important than the horizontal resolution, the camera and its monitor can be turned on their sides, thereby taking advantage of the greater horizontal resolution by using it in the vertical direction.

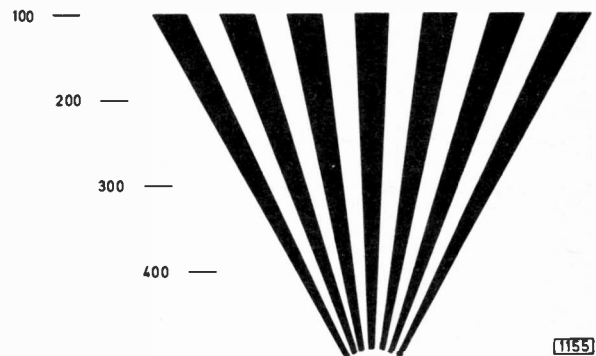

Fig. 3: A resolution wedge. Most test charts have both vertical and horizontal wedges at the centre and the corners—the maximum resolution obtainable drops off away from the centre.

We are generally more interested in the horizontal resolution figure as a guide to a camera's performance. Test charts contain blocks of various numbers of lines (as shown for example in Fig. 1, together with the waveform of one line through them) and these are generally marked with the equivalent number of lines per picture height, usually in steps of 100 lines.

The maximum resolution of the camera is assessed visually from the monitor picture (assuming that the monitor's performance is superior to that of the camera under test) by seeing which is the finest line structure that can be seen. This is accurate to only the nearest 100 lines of course but is usually sufficient. Assessment can be carried out more accurately by using the wedges featured on many charts (see Fig. 3) in one or both directions. The technique is to look along the wedge from the widest end to the narrowest end to see where the lines merge into a grey mass, then to read off the number opposite. This is not as simple as it sounds as the line of demarcation is not clearly defined.

Oscilloscope Tests

For a more accurate measurement—one that is independent of the monitor's performance—an oscilloscope fitted with a delayed timebase facility can be used. Such a 'scope has two independently adjustable timebase circuits and by the use of suitable triggering a single line of video information can be selected from the video waveform.

Fig. 4 shows the basic principle. A simple (non-delay timebase) 'scope has the X sweep fired once every line (when the timebase frequency is suitably set) so that all the lines (1–625) are displayed superimposed. The delay timebase enables the main timebase to be fired for the duration of one line once every two fields (i.e. on the odd field every time or on the even field). The display will consist of say the 234th line only. The main timebase can be set to fire for more than one line if desired. A multiturn potentiometer allows different lines to be selected so that lines from different parts of the frame may be displayed for analysis.

Provision is made for identification of the lines being displayed by a "set" position on a selector switch

(different 'scopes differ in detail). Typically when the timebase frequencies are suitably set a complete field or the whole frame may be displayed. The portion to be displayed in the "delay" position (i.e. when the 'scope is functioning as in Fig. 4) will appear as a brightened up portion that can be shifted along the frame waveform to the point of interest and widened or narrowed by adjusting the timebase controls. Switching to the delay position will then display just this portion. The line or lines that are displayed are said to have been strobed out of the main waveform.

Picture and Waveform Monitor

A sophisticated version of this is found in broadcast standard and more advanced CCTV studios and is known as a picture and waveform monitor—PWM for short. As its name suggests, it consists of a monitor and 'scope mounted in a common chassis, the 'scope displaying the video waveform—line or field selected by a switch. The same switch is also used to bring in a delayed timebase in the manner described above. A pulse starting at the same instant as the strobed-out line and lasting for the same time is taken from the timebase, and is of polarity and amplitude such that when mixed with the video waveform the monitor is driven to peak white for its duration. It is possible therefore to see directly from the monitor which line is being strobed out and it is a simple matter to select a line from any area of the picture for close analysis. To measure the horizontal resolution we want to be able to look at lines which run through the centre (approximately) of the blocks of resolution bars.

With the dual timebase 'scope it is not quite so easy to locate the blocks. Their position on the video waveform can be determined by inspection or by running a screwdriver blade down the edge of the test chart being viewed by the camera until it is at the position of the blocks. The black "blip" that this causes can be seen running along the frame waveform with the 'scope in the "set" position. The strobed-out portion is then set to this point and adjusted to be of one line duration.

Bandwidth

We have already seen what the waveform of a single line looks like under these conditions (Fig. 1). In practice some of the finer bars will be unresolved. If not a test chart containing blocks of a finer structure should be used. Optimise the electronic and optical focusing and read off the maximum resolution from the 'scope by tying up the bars with the numbers printed on the test chart. The 'scope must have a greater bandwidth than the camera and the camera should be properly terminated. This measurement is independent of a monitor of course. The bandwidth (which as we have seen is directly related to resolution) of a typical CCTV camera should be flat from d.c. to about 8MHz—no mean achievement. For this reason any controls that affect the bandwidth should not be touched unless the manufacturer specifically recommends it.

Hi-Peaker

There are one or two bandwidth controls which are user optimised during camera setting up however.

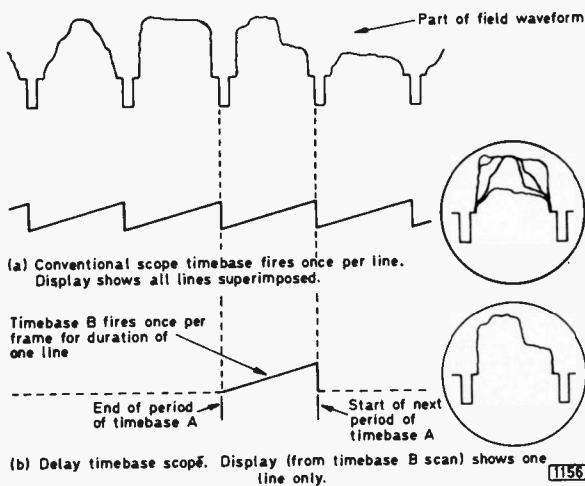

Fig. 4: Comparison of the operation of conventional and delay-timebase oscilloscopes.

Most common is that in the hi-peaker stage. This stage compensates for the fall off in the vidicon's high-frequency output (and consequent loss of fine detail) due to the input capacitance of the first video amplifier and the stray capacitance arising from the interconnecting wiring which together shunt the very high vidicon output impedance. The shunt capacitance present introduces both an amplitude fall-off and a phase shift at the higher frequencies, resulting in smearing and a loss of resolution. Suppose a camera is looking at a black/white/black block: if smearing is present there will be a "tail" of black into the middle white block and a "tail" of white into the right-hand black block—as if they had been chalked in and someone had smeared them across with a duster.

A common type of hi-peaker stage is shown in Fig. 5. As the frequency of the input signal increases, the reactance of the peaking capacitor (200–800pF) will decrease, reducing the effective emitter impedance and thus raising the stage gain. In consequence the higher frequencies will be amplified more than the lower frequencies. The capacitor is generally made variable to enable optimum correction (maximum resolution with minimum smearing) to be obtained. By suitable choice of components the phase characteristics of the circuit can be made equal and opposite to those of the input, so that they cancel out.

Cable Correction

Cameras having a separate head unit often have a similar stage near the input to the main amplifier to correct for losses and phase shifts in the cable. It is important for the capacitor to be variable in this case since cable lengths will vary from application to application. When used for this purpose the control is known as cable correction, not as a hi-peaker.

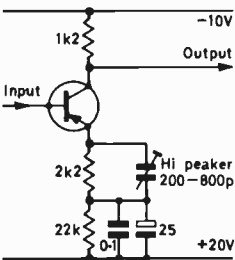

Fig. 5 (left): Circuit of a common type of hi-peaker stage.

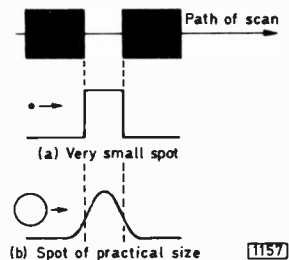

Fig. 6 (right): The mechanism of aperture distortion.

Aperture Distortion

A second type of loss, common to all TV cameras, is aperture distortion. This arises because the scanning beam has a finite size instead of being the point that is assumed for simplicity in general descriptions. Consider a very small scanning spot traversing a black/white/black block—see Fig. 6(a). The spot, having negligible width, can make a transition in virtually zero time so that the output waveform is in this ideal case a square wave. A spot of more practical size however, see Fig. 6(b), takes time to make the transition. When

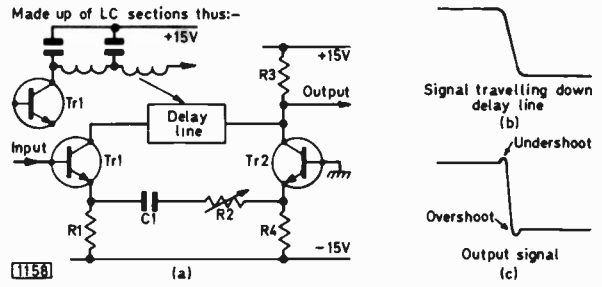

Fig. 7: A typical aperture correction circuit.

it is halfway across the transition the spot will be half on black and half on white and the camera will "see" only the mean value of the illumination at that point—a mid-grey. This results in the output waveform shown in Fig. 6(b) and limits the fineness of the line structure that can be seen.

This type of distortion can be electronically compensated in the video processing circuits. The effect, after correction, is as if an aperture—reducing the size of the electron beam—had been inserted into the camera tube: hence the term aperture correction. This type of distortion causes a fall off in the high-frequency response but in general no phase shift is introduced. Compensation for this calls for special circuit techniques—the circuits used for hi-peaking and cable correction, with their inherent phase shifts, are unsuitable.

Delay Line

Aperture-correction circuits commonly use delay lines and a typical circuit (simplified) is shown in Fig. 7(a). The incoming signal is applied to the base of Tr1 which acts as a splitter, passing signals of opposite polarity down the two signal paths, one directly from its emitter through C1 and R2 and the other via the delay line to the collector of Tr2. Looked at another way, since the undelayed signal gets to Tr2 first it can be said to anticipate the delayed signal. If a negative-going transition travels down the delay line—see Fig. 7(b)—a positive-going transition will appear at the collector of Tr2 slightly before it; the signals add, and the net effect is to cause the output signal to undershoot, or preshoot as it is also called. The direct signal also travels back from the collector of Tr2 up the delay line, and is reflected from the far end because of the comparatively high impedance of Tr1 collector. It returns as a reverse-polarity signal at the collector of Tr2 so that the output overshoots at the end of the transition. The overall effect is to sharpen the transition edges without introducing a phase shift. R2 is made variable to adjust the amount of undelayed signal reaching Tr2 and hence the amount of correction applied.

Aperture correction is normally set up on a single, strobed out line on a 'scope by adjusting for maximum resolution. Care must be taken not to over-correct as this can lead to the introduction of noise or oscillation (recognisable on the 'scope by the appearance of a sort of shimmering grass display in the finer resolution blocks).

Similar circuits are sometimes encountered mounted in a separate unit for processing the video signals from the camera. The process is then referred to as edge enhancement or crispening.

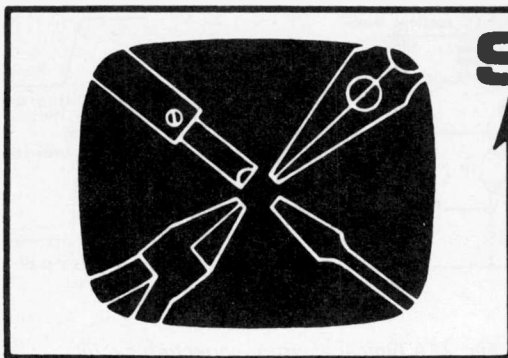

SERVICING television receivers

L. LAWRY-JOHN'S

HYBRID PYE COLOUR CHASSIS

FROM the original Pye 691 dual-standard chassis which was marketed under several brand names including Invicta, Ekco, Dynatron and Ferranti, there has evolved a series of improved designs culminating in the last of the Pye group's hybrid colour chassis designated the 697. This uses a vertical printed board in place of the large metal screened box which contained the line output stage valves and transformer in the earlier versions. Between the first and last basic designs there was an intermediate version which dispensed with the GY501 e.h.t. rectifier and PD500 e.h.t. stabiliser triode used in the earlier models, employing an e.h.t. multiplier tray instead but retaining the large screened line output section with its wired components.

Only the earliest models (Pye CT70, Ekco CT102 etc.) were of the dual-standard variety, all others being for u.h.f. reception only and thus presenting a far less complicated tuner, i.f. strip and convergence set up. This certainly makes life a lot easier, but there is one disadvantage. It is quite often the case that some of the convergence controls and associated components give trouble. The duplicate set for 405-line operation were very rarely used and can be brought into operation by disconnecting the system switch and leaving the convergence section in the 405-line position, thus obtaining a nice new set of controls etc. except of course for those common to both systems (well you can't have it all can you?). Apart from faulty controls the items to check in the event of stubborn convergence problems include the AC128 clamp transistors and the reversible electrolytics on the panel.

Before going further we had better warn that there were quite a number of changes during the long production run of these chassis and one consequence of this is that many of the component reference numbers used in the various versions differ. This is particularly the case in the line timebase. The component reference numbers used in this article relate to the original dual-standard chassis unless otherwise indicated.

Sync Faults

A common fault with these sets is weak sync. The BC107 sync separator transistor VT6 sits on the i.f. panel and is operated from an h.t. rail obtained via a resistor (R389) on the luminance/colour-difference amplifier panel. Its base is biased by a potential divider and it is the upper resistor here, R33 4.7M Ω , that is nearly always responsible for this trouble. We got caught once when the resistor was all right and the transistor seemed to read correctly, but it turned out to be the BC107 in the end. The fault has also been

traced to the BC107's base-emitter junction protection diode D3 (OA47) being defective. This is connected in series with the emitter of the BC107.

Loss of sync along with loss of colour occurs when the 3.9k Ω wirewound resistor R389 on the right side of the luminance/colour-difference panel goes open-circuit. This resistor feeds the screen grids of the three PCL84 colour-difference output valves and as we have seen also provides the h.t. for the sync separator circuit. In later models fitted with a varicap tuner it was changed to 3.3k Ω and can spring open for no apparent cause, thereby causing loss of signals since the tuning voltage is derived from this line.

No EHT

There is a tendency for insulation deterioration to occur in older models, both under the line output section and at the top front. Cut away the affected section and rewire as necessary: this does not call for description and in any case the condition will vary from set to set.

A common cause of no e.h.t. is an open-circuit line output valve screen grid feed resistor (R232, 2.7k Ω). You may find that this component is intact electrically but that it has parted company with the panel to which it should be wired. As switching is no longer necessary it can be wired directly from L43 to the PL509 base, leaving the associated decoupling capacitor C231 in its original position.

In later versions which use an e.h.t. multiplier tray failure of this component is a common cause of no e.h.t.—or lack of width. If it is necessary to replace the tray C226 should also be checked. This is the first capacitor of the multiplier chain but is mounted externally. If defective it could have caused the failure of the original tray and will mean that the new one has a short life.

The line output stage can be killed or less seriously overloaded if C229 which smooths the feed from the boost rail to the c.r.t. first anode potentiometers is defective. If this is found to be the case the associated resistor R228 should also be checked.

A clean-up job is often necessary at the base of the GY501 e.h.t. rectifier and the top cap of the PD500 shunt stabiliser—it's a good idea to replace both these valves at the same time to avoid almost certain recall later. This also holds good for the PL509 line output valve and the PY500 efficiency diode—they also seem to affect each other. Another lesson we have learnt is to look at the top caps of these valves before refitting: a goodly number are not properly soldered.

When the customer complains of smoke it is a fairly

Fig. 1: Circuit of the line timebase used in earlier (dual-standard) models.

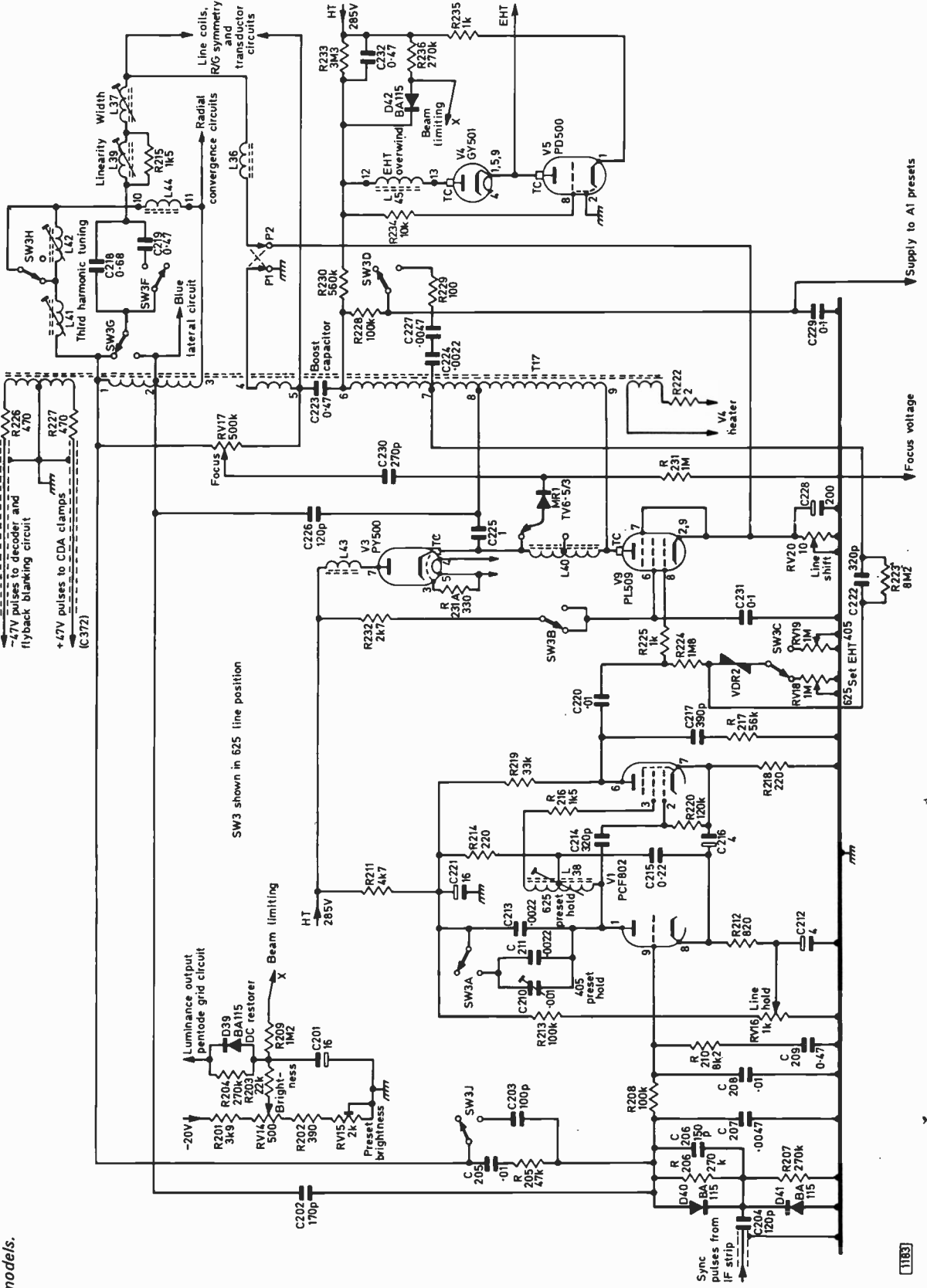

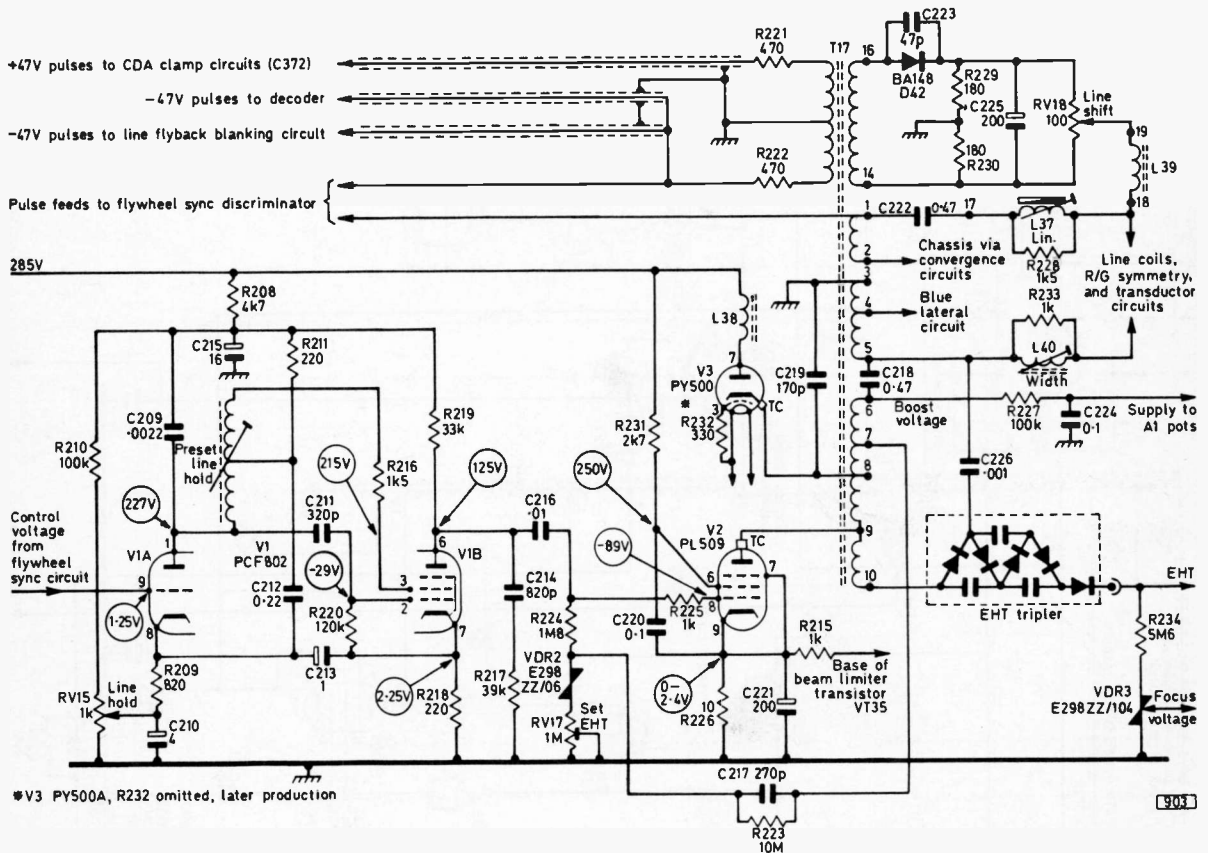

Fig. 2: Line oscillator and output stages used in single-standard chassis. In later production C219 is 180pF and is connected between tags 8 and 1 of T17; RV18 is centre-tapped and R229, R230 are omitted.

safe bet that the line output transformer will be found in some state of distress and in need of replacement. The design of the transformer has been changed through the different versions however and it is now more reliable. In those single-standard chassis which retain the metal housing we have in several cases found the transformer all right but the transformer tuning disc ceramic capacitor (C219, 170pF pulse) completely blackened and split in two. Removal of the rear plate leaves the capacitor in view at the top left side of the transformer where it is easily replaced.

In other cases the lead feeding the e.h.t. tray is connected to the transformer solder blob at an angle, resulting in discharge to the windings. The consequent damage may make it necessary to replace the transformer. This is not always the case however: sometimes the insulation can be repaired and the cable presented directly to the soldering blob (not at an angle) thus saving the cost of a new transformer. This particular point applies mainly to later sets with the printed panel. The complaint of smoke from these later sets need not indicate component failure at all: we have often gone along well armed with a replacement transformer and the usual items only to find that the trouble is due to conduction across the panel at the top, adjacent to the input fuse. The action required here is to scrape away the tracks affected and fit wire connections in place of them.

When a new line output transformer has been fitted there can be some odd side effects which arise as a

result of removing and replacing the right side unit, particularly when this is of the later type with edge connectors along the top and down the left side. One can take great care to dismantle the various bits and pieces, fit the new transformer and put everything back in the right order but still be faced with all sorts of troubles when the set is switched on. These may range from loss of signals to the strangest looking convergence you've ever seen. The thing is not to panic (just run for your life!). Edge connectors are all very well provided they connect. Then again the connectors may well connect but the wires inside may not have been soldered in the first place. They just sit there working happily until they are disturbed, after which they look innocent enough but following removal and replacement of the panel just do not connect. Check each one: it saves a lot of time in the end.

Lack of Width

When the complaint is lack of width, perhaps coupled with a long wait for the picture to appear, the first items to check are the PL509 and PY500 valves. In most cases this will clear up the trouble and probably make the picture better than it has been for some time (that's what the customer usually says). There are times however when valve replacement is not the answer. It then pays to check the high-value resistor R223 (8.2M Ω or 10M Ω , or it may be two resistors totalling roughly this value) which provides a d.c. path between the boost

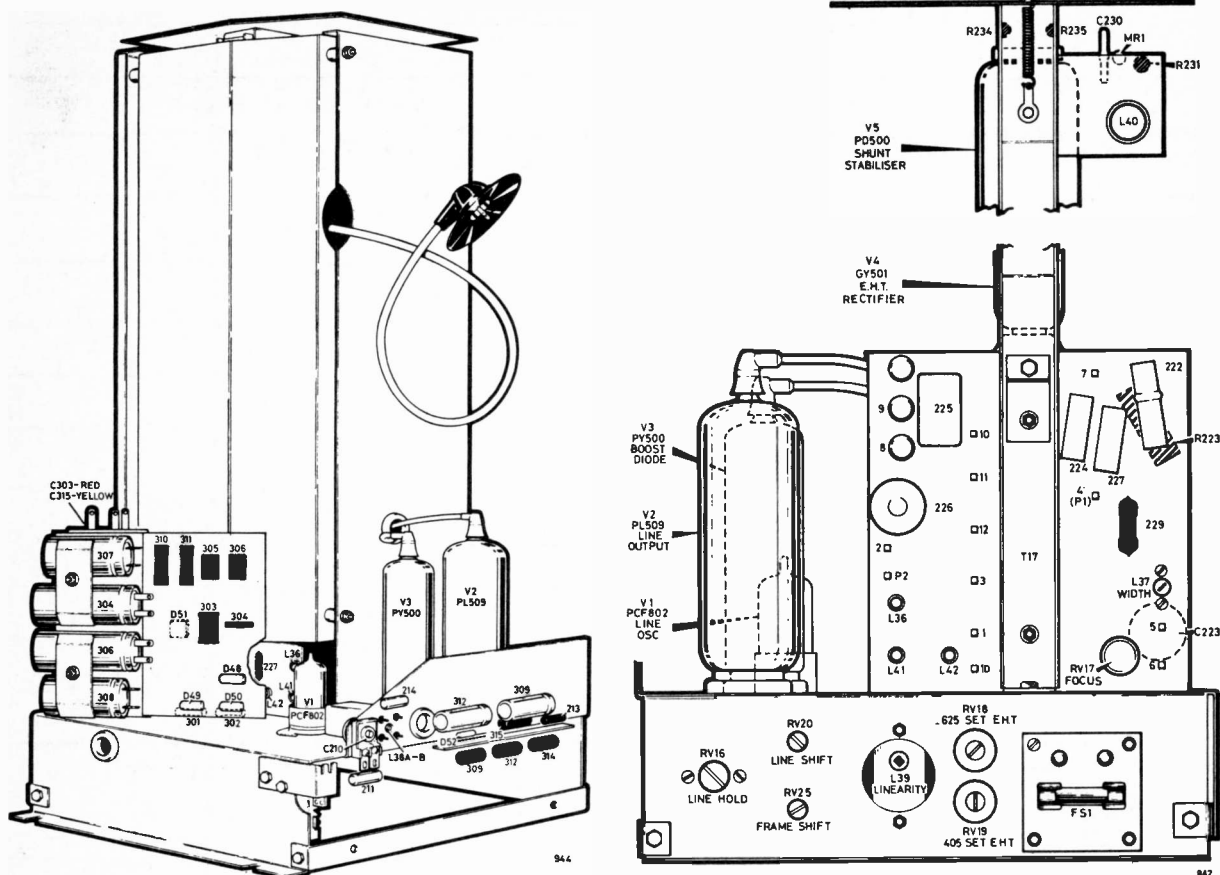

Fig. 3: The line output assembly used in dual-standard sets.

line and these h.t. controls. This can go high-resistance. The associated pulse feedback capacitor C222 can also play games, and either component can be responsible for fluctuating width. The voltage-dependent resistor (VDR2) rarely gives trouble. The set e.h.t. control(s) can suffer from poor contact however, and it is vitally important not to have any hanky-panky here. Replace the control concerned and probably save the cost of a new line output transformer.

Boost Capacitor

It should be noted that one end of the boost reservoir capacitor C223 (0.47 μ F) is from the d.c. point of view returned to chassis. When it goes short-circuit therefore an intolerable load is presented to the PY500. No mystery here.

Striations

There is also no mystery about the appearance of striations (vertical rulings) down the left-hand side. R215 (1.5k Ω) wired across the line linearity control tends to go high-resistance thus removing the damping from the coil.

In single-standard models a variable control RV41 is connected across the parallel-connected pincushion distortion correction transducer windings to provide N/S amplitude adjustment. This quite often burns out

to give the symptom of light horizontal striations across the top of the screen.

Line Oscillator

Line oscillator troubles can usually be sorted out by replacing the PCF802 or making a general check on the associated capacitors including the feedback coupling capacitor C214 which is a less obvious suspect than the cathode coupling electrolytic C216. When C216 is defective it can produce a fault condition whose cause is not so obvious, a bright vertical band down the centre of the screen. Other components which can give trouble in this area are the 16 μ F h.t. smoothing electrolytic C221 which can cause line hold variations, and the associated 4.7k Ω h.t. feed resistor R211 which when it goes open-circuit kills the line oscillator and results in an overheated PL509 and PY500.

Focus Troubles

Focus troubles in the dual-standard chassis should direct attention to the control (RV17), C230 which is connected to its slider and the focus rectifier MR1 which can be damaged if C230 is leaky.

If in later versions the focus is far out but the raster is of full width the v.d.r. focus unit is likely to be suffering from poor slider contact, a broken spring or cracked rod element—the rod tends to fracture at the centre.

CONTINUED NEXT MONTH

LONG-DISTANCE TELEVISION

ROGER BUNNEY

WITH the start of the New Year this is the time to look back over 1974's reception and forwards in anticipation and the hope of even better things. The past year was a good one, at least for Sporadic E reception. We didn't have the intense and frequent openings experienced during the same period in the previous sunspot cycle but the season was noteworthy for the predominance of really long-hop signals. We had reception—more than once!—from Ghana, Lebanon and the Russian Yerevan, and numerous sightings of 525-line system M signals, certainly Crete ch. A2, the Canaries, Jordan and possibly Egypt.

Meteor-shower reception increased in interest. Several enthusiasts are now active in Band III and had notable successes—Finland (YLE), Poland (TVP), USSR (TSS), Switzerland, Austria and Italy—in fact most countries within the short- to medium-hop range of SpE. Some Auroral activity was noted, including successful sighting of YLE chs. E2 and E3.

The disappointment of the year was the lack of tropospheric towards the end—indeed the really good activity for this mode occurred last January, with quite remarkable reception in all parts of the UK from West and East Germany, Scandinavia, Switzerland and Austria. The first over 1,000 mile Swedish u.h.f. tropospheric signal was noted in East Anglia during this period.

My hope for 1975 is that conditions will be better for all distances via SpE. This would certainly be an encouragement for the many newcomers to DX-TV. Next month we plan to cover SpE theory again, including Band III SpE which does occur at times.

For the present we have to lament on the poor conditions prevailing this January. I don't expect conditions to pick up until mid-March when we should start to see increasing numbers of short SpE openings—the first three months of the year always tend to be no-go periods!

Monthly Report

My log for the period consists of mainly MS reception—particularly during the Quadrantids on the 3rd. All loggings are MS unless otherwise indicated.

- 1/1/75 TVE (Spain) chs. E2, 3, 4.
- 2/1/75 DFF (East Germany) E4; CST (Czechoslovakia) R1; WG (West Germany) E2.
- 3/1/75 TVE E2, 4; SR (Sweden) E2, 4; ORF (Austria) E4; NRK (Norway) E4; DFF E4; CST R1 (Quadrantids MS).
- 4/1/75 RAI (Italy) IB.
- 6/1/75 WG E2.
- 7/1/75 DFF E4; WG E3; SR E2.
- 8/1/75 DFF E4; WG E2; TVP (Poland) R1.
- 9/1/75 DFF E4; improvement also in tropo, mainly France at u.h.f.
- 10/1/75 WG E2; improved tropo as on the 9th.
- 12/1/75 WG E4; TVE E4 (SpE); unidentified MS E4 signal—see later.
- 14/1/75 SR E2.
- 16/1/75 WG E2; TVE E2, 4; TVP R1.

- 17/1/75 DR (Denmark) E3.
- 18/1/75 NRK E4; RAI IB.
- 19/1/75 WG E2.
- 20/1/75 WG E2, 4.
- 21/1/75 WG E4.
- 22/1/75 WG E4; TVE E2.
- 24/1/75 WG E4.
- 25/1/75 RAI IB; ORF E2a.
- 26/1/75 WG E3, 4.

Along with the changes in the organisation of the French television services have come alterations in the various patterns used. For a few days in early January the Lille second chain outlet on ch. E21 deleted the "ORTF" identification, being radiated plain. On the 16th I noted a new identification on the 5544 card: in the top panel "TDF" and in the lower panel "Antenne 2". Ian Beckett has provided information on the identification captions used by the various networks. The first chain now carries the identification "tf1" (Television Francaise 1), the second chain "antenne 2" and the third chain "FR3" (France Region 3). As soon as photographs are available we will show them.

An interesting reception occurred on the 12th at 0829 on ch. E4 via MS, consisting of a slide showing a flag with the pole to the left-hand side of the screen and writing across. This would seem to be the opening sequence for a network. Has anyone else seen it?

I logged a fair tropospheric opening on December 31st, mainly into France. This gave me three new stations including a new Le Mans third chain transmitter on ch. E21. A small SpE opening occurred on the 29th, unfortunately entirely programme material. All channels in Band I were affected. Another SpE opening occurred on Christmas Eve. I missed this but Hugh Cocks noted TVP, YLE and SR at midday while a second opening in the evening brought MT (Hungary). Hugh also noted TVE in Band III again—ch. E11—via tropo on December 31st.

Improved tropo on January 4th included an unusual if not unique Fubk test card carrying the identification "PTT TEST". This was from a Swiss outlet. Chs. E31 and E34 were also noted. TVE chs. E9 and E11 were logged at weak to fair on the 6th, 7th, 9th and 10th. In another letter Hugh Cocks detailed SpE reception between 1600-1730 during the period December 26th-29th, including RAI, JRT (Yugoslavia), NRK, SR and TSS.

New EBU Listings

West Germany: Boppard ch. E28 reduced from 250kW to 160kW, ch. E41 increased from 120kW to 230kW.

Austria: Wien 1 ch. E24 increased from 400kW to 1,000kW.

Finland: Koli ch. E51 600kW horizontal, YLE 2.

France: Gex 3rd chain ch. E24 100/200kW (200kW to NW); Niort 3rd ch. E25 200kW; Meziers 3rd ch. E26 500kW; Rouen 3rd ch. E26 500/200 kW; Caen 3rd ch. E28 1,000kW; Mende 2nd ch. E31 80kW (South France); Reims 3rd ch. E40 1,000kW; Le Havre 3rd ch. E40 100kW; Neufchatel 2nd ch. E48 80kW (west of Paris); Montpellier 3rd ch. E53

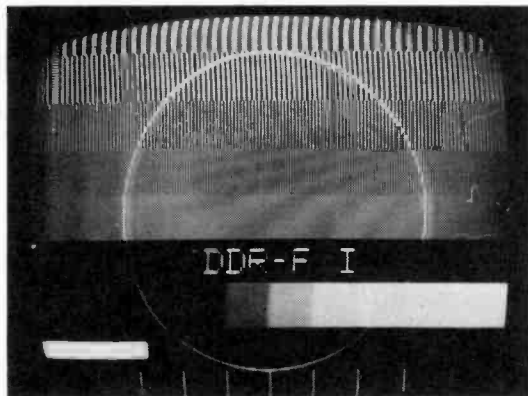

DDF-1 test pattern—East Germany, GDR (courtesy Ralf Erler).

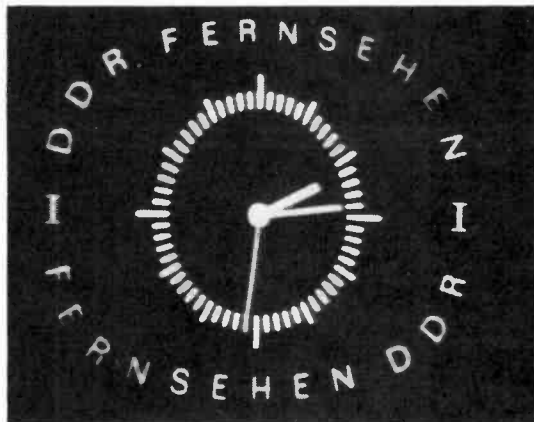

DDF-1 clock (courtesy Dieter Scheiba).

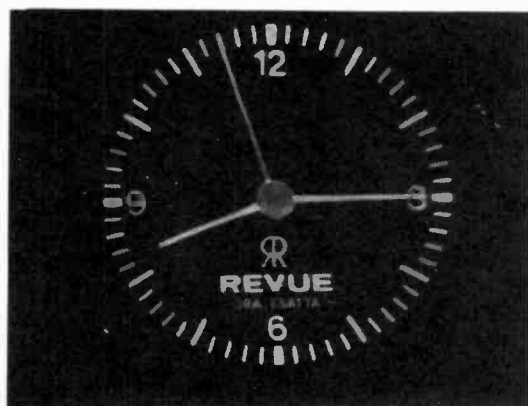

Tele Capodistria clock, Yugoslavia—Italian language programmes (courtesy Michele Dolci).



EBU pattern as used by MT-1, Hungary (courtesy Hetesi Laszlo).

1,000kW (south of France); Laval 2nd ch. E57 100kW and Mantes 2nd ch. E58 80kW (both south of Rouen); Bayonne 3rd ch. E61 300kW (adjacent TVE border—west); Mantes 3rd ch. E61 80kW; Dijon 3rd ch. E65 1,000kW. All with horizontal polarisation.

Switzerland: Les Ordonns ch. E31 (German), ch. E34 (Italian), 14kW each with horizontal polarisation (NW Switzerland).

News Items

Zaire: French television technicians have been installing near Bandundu an experimental relay transmitter powered by solar cells.

Egypt: Egypt is planning to convert its three-channel TV system to colour by mid 1975—three channels in Cairo, two in Alexandria and one elsewhere. Marconi is to supply much of the colour equipment and train the technical staff on site. Some mystery surrounds the transmission system to be used and the colour standard (PAL or SECAM).

Bahamas: *Wireless World* recently published information on an airborne TV transmission system using a balloon. Further information has now come from the WTFDA. The unit has an e.r.p. of 5kW which is directed by a Yagi array towards Nassau on New Providence Island. Transmission hours are 1200-2400 Wednesday-Sunday inclusive. The programme sources are by off-air pick-up from WPTV ch. A5 West Palm Beach Florida and WTVJ ch. A4 Miami,

and from videotape at the High Rock, Grand Bahama Island control centre. The balloon is moored over the High Rock centre and apparently a QSL card is issued detailing ZFHQ-6 on ch. 11.

Spain: Following reports of area identifications on the TVE test card we now have details of TVE regional programming. The regional programmes are transmitted from 1400 to 1415 CET and originate from studio centres at Santiago de Compostela (called Panorama de Galicia); Oviedo (Panorama Regional); Barcelona (Panorama Regional); Madrid (Desde la Bola del Mundo); Sevilla (Telsur); Valencia (Aitana). Thanks to Keith Hamer for this information.

1975 Meteor Shower Dates

Quadrantids: January 1st-6th, peaking on the 4th at 0400 GMT.

April Lyrids: April 19th-24th, peaking on the 22nd at 1300.

May Aquarids: May 1st-8th, peaking on the 5th.

June Lyrids: June 10th-21st, peaking on the 16th at 1400.

Capricornids: July 10th-August 15th, peaking July 25th-26th.

Aquarids: July 15th-August 15th, peaking July 17th-28th.

Perseids: July 25th-August 18th, peaking on August 13th.

Cygnids: August 19th-22nd, peaking 20th-21st.

Orionids: October 16th-26th, peaking on October 21st.

Taurids: October 20th-November 30th, peaking on November 8th.

Leonids: November 15th-19th, peaking on the 18th at 0100.
 Geminids: December 7th-15th, peaking on the 14th at 2100.
 Ursids: December 17th-24th, peaking on December 22nd.

In addition there are four showers which will be visible in Australasia, as follows:

Corona Australids: March 14th-18th, peaking on the 16th.

Ophiuchids: June 17th-26th, peaking on June 20th.

Pisces Australids: July 15th-August 25th, peaking on July 31st.

Phoenicids: December 4th-5th, peaking on the 4th-5th.

Our thanks to Keith Hamer for obtaining this information from the BAA.

Letters

Due to the amount of information this month we are holding over comments from readers' letters till next month.

Moonbounce: Go or No-go?

We received a letter recently from Bryan Jones of Iver Heath, Bucks in which he expressed his thoughts on the possibilities of receiving moon-bounced signals of a domestic television nature from the USA. I feel that new possibilities should always be considered and that Bryan's thoughts should be given an airing. We would be delighted to hear from anyone with views on or experiences in this field.

Bryan comments that the results achieved so far have been by amateurs using relatively low powers (compared with television transmitters) and very narrow bandwidths (3kHz or under compared with the bandwidth of about 1MHz required to resolve a recognisable vision image). We would have to wait until the early hours when the local transmitters are off and the moon is high in the sky. Consequently the USA networks would be on evening programming and aerials would have to be pointed upwards.

It appears that some form of signal focusing occurs in the Troposphere on such a space travelling signal and this is going to help. At u.h.f. the path loss for a moon-bounced signal at 432MHz is 261dB: thus with a 1kW transmitter at one end and an aerial with 30dB gain at the other the result will be a signal of the order of 0.03 μ V.

The best path is when the moon is high, as the transmitting and receiving sites will both be looking through comparable electron densities. A 2dB saving in path loss has been noted from experiments when the moon is at perigee (closest to the earth). Avoid times near to full moon when the sun is in close proximity (thus avoiding solar noise). Signals tend to be stronger in the autumn and winter and weaker in the summer, the signals being best at night. Aerial height is of little importance when using the moon at a high elevation—there must of course be a clear take-off. Some method of rotating the aerial system as the earth rotates needs to be devised. The July 1974 QST gives a check list which we have altered slightly to cover TV-DXing needs:

- Can both sites observe the moon at almost similar angles?
- Can the other site see the moon at this time?
- Is the distant transmitter in operation at this time?
- Is the moon at perigee but not too close to the sun?
- Is the moon in the correct declination and elevation?
- Is the moon in the right galactic plane, i.e. sited so as to avoid high galactic noise sources such as Orion and Gemini in northern declinations, Scorpio and Sagittarius in southern declinations.

Amateur stations which have been successful in these activities have used quite low powers and sometimes reasonably small aerial arrays. WA6GUY used 100W and a forty-



The Neiderhorn transmitting mast (Switzerland), 1947 metres a.s.l. Chs. E12, E27. Photo courtesy K. Hamer.

element array, K3PGP 500W and a 96-element array, WOLER 1kW and a stacked ten-element array, K6QEH 1kW and a single sixteen-element array. W4WNH/8 in listening to these experiments achieved good results using a single thirteen-element array. The results were reported by Stanford University during a specific test period. The University itself used a 150ft. dish! The tests were conducted on the 2 metre band (144MHz).

It can be seen then that moon-bounced signal reception is a technique that works. Whether it can be exploited as another means of obtaining DX-TV remains to be seen. If anyone meets with success we hope they will let us know at once.

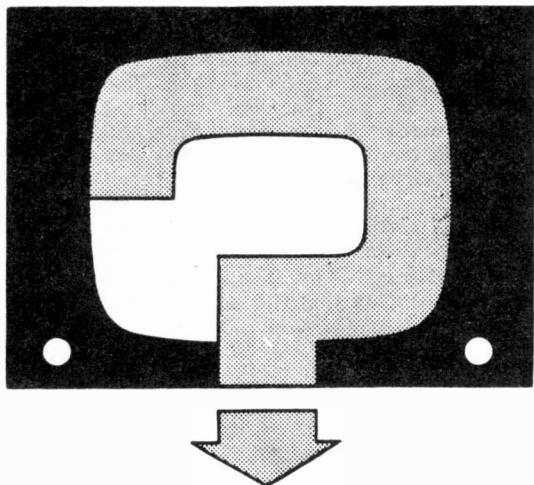

YOUR PROBLEMS SOLVED

★ Requests for advice in dealing with servicing problems must be accompanied by an 11p postal order (made out to IPC Magazines Ltd.), the query coupon from page 281 and a stamped addressed envelope. We can deal with only one query at a time. We regret that we cannot supply service sheets or answer queries over the telephone. We cannot provide modifications to circuits published nor comment on alternative ways of using them.

EKCO CT252

The problem appears to be in the luminance delay line circuit since the chrominance image overlaps the luminance on the right-hand side by about 3/16in. The luminance delay line circuit has been checked for short-circuits, unsoldered connections, earth disconnections etc. but everything seems to be in order.—G. Owen (Litchfield).

You may have a luminance delay line which is a bit short, in which case another 100 turns of 42 s.w.g. wire wound on either end would help. Check also the decoder tuning—it may be peaked too much and in need of broadening to increase the chrominance bandwidth. To do this screw in the core of the first chrominance transformer T8 until it is two turns into the former and unscrew the core of the coil (L29) in the base circuit of the second chrominance amplifier until it is two turns out. This is not a critical adjustment and can be carried out with the set cold. (Pye group 697 chassis.)

HMV 2802

The fault with this set is loss of line hold. The trouble appears to be in the flywheel sync d.c. amplifier circuit since this transistor's collector voltage jumps up to about 80V instead of 44V. A new transistor was fitted and hold obtained at mid-travel but after about a quarter of an hour the collector voltage again went up to 80V and hold was lost.—R. Dodson (Canterbury).

The d.c. amplifier transistor could be at fault but we would have thought a drop in its base voltage to be a far more likely cause of the trouble. Check the electrolytic (C51) in the flywheel sync filter circuit, the discriminator diodes (W3, W4) and if necessary the other components in this area. (Thorn 1500 chassis.)

BUSH CTV194

For a short period immediately after switch-on, before sound or vision appear, there is a brushing type of electrical noise. The receiver otherwise operates satisfactorily.—J. Goodley (Bromsgrove).

The noise you can hear is probably the degaussing coils being energised when the set is switched on, then dying down as the current through them falls. If the noise is loud we suggest you examine the coils in case there is insulation breakdown.

GEC 2047

There is a line sync fault on this set, the display consisting of two pictures side by side. All relevant valves have been replaced.—T. Orvin (Colchester).

We assume that the setting of the preset line hold control P205, which is roughly in the centre of the printed circuit board, has been checked. If so we suggest you check the components in the screen grid circuit of the sync separator section of the PFL200 valve—the potential divider R141 (47k Ω) and R142 (27k Ω) and the decoupler C134 (0.047 μ F).

ULTRA 6649

The problem we have with this set is that the width control keeps burning up, hot-spotting on its carbon track. It seems that the component is overloaded for some reason.—B. Richards (Gloucester).

The width control is connected in series with a 330k Ω resistor (R143) across the boost h.t. rail. If R143 changes value—as it sometimes does—excess current will flow through the width potentiometer. It is more likely however that the pulse feedback capacitor to the width circuit (C113, 100pF) is leaky. Replace this (note that it is a 2kV pulse type) and also check the width circuit v.d.r. (Z4) since this can be damaged if C113 breaks down. (Thorn 1400 chassis.)

EKCO CT121

This set seems to have very poor line linearity—the left-hand side of the picture is much wider than the right-hand side. The line linearity control affects only the left-hand side of the picture.—G. Pounder (Tamworth).

It is quite normal for the line linearity control to affect only the left-hand side of the picture, but in doing so it should be possible to achieve reasonable overall linearity. If not, we suggest you check the value of the 1.5k Ω damping resistor R228 which is wired across the linearity coil. This is the most common cause of non-linearity in these models. (Pye group 693 chassis.)

ALBA TC1717

When the set is switched on the raster first appears with horizontal, yellowish lines across it. Then after about three minutes the screen is filled with lines as though both the field and line hold have been lost. After a further minute the picture suddenly appears and is generally satisfactory for as long as the set is left on.—M. Stapleton (Pontefract).

If both the line and field hold are lost, suspect the tantalum electrolytic gremlin C196 (3.3 μ F) on the signal board. This capacitor provides coupling between the first video amplifier and the sync buffer amplifier. If only the line hold is affected suspect the BA154 flywheel line sync discriminator diodes W405 and W406. These diodes are often proved faulty through substitution even when ohmmeter checks suggest that they are o.k. After replacing them the line oscillator coil L405 (line hold control) should be adjusted as follows: link the two pins adjacent to the coil's screening can and adjust the core for a floating but resolved picture; line lock should then be obtained on removing the link. (Thorn 8000 chassis.)

DECCA MS2000

We are having difficulty curing a case of horizontal cramping at the centre of the screen on one of these sets. Adjusting the linearity sleeve has no effect on the fault while the scan correction capacitor and the components between the line oscillator and line output valve have been tested and found to be o.k.—F. Raison (Darlington).

This fault can be caused by changed value resistors in the grid circuit of the section of the cross-coupled line multivibrator valve that conducts during the scan. This grid is biased from a potential divider (R139 and R140) between the h.t. line and chassis, the junction of these two resistors being linked to pin 2 of the ECC82 by a third resistor R130 (680k Ω). R130 is likely to have increased in value but the values of the other two resistors (330k Ω and 56k Ω respectively) should also be checked.

PHILIPS 19TG122A

The e.h.t. went suddenly. The valves in the line output stage have been replaced with no luck. All valves light up except the DY86 e.h.t. rectifier, and the sound is still present.—J. Hartman (Blaina).

To the left of the screened line output section is a large capacitor—the boost reservoir capacitor C405, 0.1 μ F 1kV—and a 2.2k Ω resistor (R410) which feeds the line output valve screen grid. Nearby is the ECL80 line oscillator. If the PL36 line output valve is quite cool check the resistor (reverse side of panel) which could be open-circuit. If the resistor is o.k. and the valve is fairly hot suspect the capacitor. If the PL36 is overheated to a marked extent suspect the ECL80.

PYE 171

The trouble with this set is field collapse—there is just a horizontal bright line across the screen. The PCL85 field timebase valve has been checked by substitution.—G. Hutton (Hounslow).

The most likely cause of the fault is transistor VT6 (BC147) which forms one half of the field oscillator stage. Check also the connections to the field scan coils. (Pye 169 chassis.)

BUSH TV141

The picture on 625 lines is o.k. until a dark scene appears. The whole picture then pulsates—from black towards white—and stays like that until the scene becomes lighter after which it is o.k. again. While the fault lasts the sound is intermittent in time with the pulsation. The contrast control has to be set fully anticlockwise (low level) to get a reasonable picture. The line hold control is almost fully clockwise. On 405 lines there is no line lock at all and a vertical black band down the left-hand side of the screen.—R. Judd (Rainham).

We feel fairly sure that the trouble on 625 lines is due to the anti-lockout circuit. Check the time-constant capacitor 2C58 (0.47 μ F) and the diode (2MR5). The hold troubles suggest that the line hold system switch section 3S2a is faulty or that 3R11 which is in series between the h.t. rail and the hold control track has changed value.

GEC 2015

The problem with this set is reduced height and bottom cramping. Both field linearity controls are at maximum and a new PCL805 field timebase valve has been fitted.—J. Mallinson (Leeds).

Check the PCL805 pentode cathode decoupling electrolytic C154 (250 μ F), also its cathode resistor R107—replace if discoloured. Check also C185 (50 μ F) which smooths the supply (HT4) to the field output stage. Check the supply to the height control—if less than 100V replace the feed resistor R101 (2.7M Ω) which often increases in value.

BUSH TV178

Due to low boost voltage there is lack of width, poor line linearity, excessive height and a poor quality picture. The boost line is down from 780V to approximately 500V. The h.t. voltages are correct and the line timebase valves have been replaced, also the boost capacitor. The line output valve screen grid voltage is correct. The line output transformer and the scan coils appear to be in order.—G. Hume (Bristol).

We suspect that the line output transformer is defective but before ordering a new one suggest you carefully check the components in the width circuit. To prove that this circuit is in order try connecting a 1M Ω resistor from the control grid of the PL504 to chassis. (Later TV161 series.)

GEC 2047

The contrast varies wildly depending on the black and white content of the picture. This in turn causes poor field sync and intermittent field roll due to the field sync pulse (WF1 on the circuit) varying in amplitude and shape. A new PFL200 video/sync valve has been fitted—the anode and screen grid voltages of the video section are too high however. The receiver gain seems to be o.k. since there is no noise on the picture.—F. Devlin (Honiton).

There seems to be something wrong with the drive to the video amplifier section of the PFL200. We suggest you carefully adjust the secondary (L106) of the final i.f. transformer, preferably on a test card. We also suspect the video detector diode D103, and suggest you check the emitter voltage of the a.g.c. amplifier transistor (TR105)—this should be 1.5V. (GEC series One chassis.)

KB VC4 CHASSIS

It is difficult to obtain line sync on this set. A picture is occasionally obtained with the line hold control turned fully clockwise, i.e. the picture just happens to lock in. The PCF802 line oscillator valve, R125 (820k Ω) in series with the line hold control and C109 which decouples its slider have all been replaced. As a temporary measure the value of R125 has been reduced to 680k Ω . This brings the line lock position back at the top end of the line hold control range, giving quite a good picture.—S. Mawson (Wellingborough).

The cathode of the triode section of the PCF802 is held at 7V by means of a potential divider network between the line oscillator h.t. line and chassis. The item we suspect is the upper resistor in this network, R131 (47k Ω). Change it to a 2W type.

PHILIPS G20T306

There is persistent line tearing on this set unless the brightness control is advanced far more than necessary. This is so even without a signal. The slightest touch on the brightness control one way or the other can start or stop the tearing. The field lock is normal and all relevant valves have been replaced. When checking

around the line output valve it was discovered that the fault cleared when the meter was connected across the control grid circuit. A temporary cure was achieved by reducing the value of the resistor (R2172) in the drive waveform shaping circuit from 82k Ω to 68k Ω and then 47k Ω , but the fault eventually returns. Now at normal brightness a well-locked picture can be obtained but alternate fields are out of register horizontally by some four inches while at high brightness levels a normally locked picture is obtained.—G. Smith (Hemel Hempstead).

Check the line output valve's screen grid decoupling capacitor C2063 (2.5 μ F)—this could be open-circuit. Also check R2168 (1.8M Ω) which returns the PL504 control grid to the width circuit. (Philips 300 chassis.)

QUERIES COUPON

This coupon is available until April 21 1975 and must accompany all Queries sent in accordance with the notice on page 279. Don't forget the 11p (inc. VAT) postal order!

TELEVISION APRIL 1975

TEST CASE

148

Each month we provide an interesting case of television servicing to exercise your ingenuity. These are not trick questions but are based on actual practical faults.

? Even with the brightness control fully advanced the picture on a KB portable set fitted with the VC11 chassis was insufficiently bright, especially under the relatively high ambient light conditions in which portables are often used. The picture tube could have been faulty of course, or the e.h.t. voltage low, but neither of these possibilities appeared likely since the picture when viewed under low ambient lighting conditions was well defined and in good focus.

Measurement with a high-resistance voltmeter revealed that the tube grid-to-cathode bias was too high even with the brightness control fully turned up. The control increased the bias as it was turned down, which is perfectly correct of course. To be on the safe side the tube first anode potential was also measured, but this was found to be well up

Attention was directed therefore to the tube cathode coupling from the video stage and to the control grid

feed circuit. The cause of inadequate bias swing as the brightness control is adjusted can be either incorrect cathode voltage (usually implying that the conductance of the video amplifier is low) or incorrect grid voltage. Data was not to hand on the voltages that should have been present, but one or two measurements in and around the circuits concerned gave the impression that the cathode voltage was fairly normal (the d.c. voltage that is) but that the grid voltage was low. The top of the brightness control is fed from the boost h.t. line via a 4.7M Ω resistor and the technician was so sure that this had gone high in value (typical of high-resistance components connected in a high-voltage line) that he was shaken to find the fault still present after replacing it.

What had the technician overlooked? See next month's TELEVISION for the solution and a further item in the Test Case series.

SOLUTION TO TEST CASE 147

Page 233 (last month)

The technician dealing with the set fitted with a Philips G8 chassis soon became aware that all was not right with the operation of the TBA550Q (in some chassis a TAA700 is used instead) i.e. Quite correctly he made careful checks of the voltages on the various pins before contemplating the tedious job of testing by substitution. This paid off since it was soon found that the supply on pin 5 was well below the specified 12V.

This supply is stabilised by a 12V zener diode (D2166) and after replacing the zener both symptoms cleared and it was possible to wind the line oscillator core back to its original setting.

TELEVISION CLASSIFIED ADVERTISEMENTS

The pre-paid rate for classified advertisements is 8p a word (minimum 12 words), box number 30p extra. Semi-display setting £4.50 per single column inch. All cheques, postal orders, etc., to be made payable to TELEVISION and crossed "Lloyds Bank Ltd." Treasury notes should always be sent *registered post*. Advertisements, together with remittance, should be sent to the Classified Advertisement Manager, TELEVISION IPC Magazines Ltd., Fleetway House, Farringdon Street, London, EC4A 4AD, for insertion in the next available issue.

SETS & COMPONENTS

250—New Resistors well assorted ½—2 watts. Carbon—Hi-Stab Oxide etc. £1.00 Post Free. Whitsam Electrical, 33 Drayton Green Road, London W.13.

BRC 2000, 3000, 3500, 8000, 8500

Panel Repairs—Singles or Bulk

All Details:

MODULAR ELECTRONICS

160 Brabazon Road, Hounslow TW5 9LP
Tel. 01-897 0976

TURN YOUR SURPLUS capacitors, transistors, etc., into cash. Contact Coles-Harding & Co., P.O. Box 5, Frome, Somerset. Immediate cash settlement.

EX RENTAL TV's BARGAIN

23" & 19" 3 Channel with U.H.F. Tuner £3.50
19" & 25" Colour from £50.00
19" & 23" tubes guaranteed from £2

All sets complete.

EDWARDS & SONS

103 Goldhawk Road, London W.12
Telephone 743-6996

CALLERS ONLY

MULLARD CAPACITORS

Polyester (280) 250V/W—.01, .022, .047, 3p (25p), .1, .15, 4p (36p), .22, .33, .47, 7p (55p), .68, 2.2, 12p (£1.00). Electrolytic—U.F. 1/63v, 10/25v, 40/10v, 80/25v, 100/6.4v, 220/10v, 400/25v, 400/4v, 470/10v, 8p (60p)—220/63v, 220/40v, 470/40v, 680/25v, 1000/25v, 11p (90p)
Prices in brackets for ten, price includes VAT, P & P 10p.

ELECTRONIC MAILORDER LTD.

62 Bridge Street, Ramsbottom, Bury, Lancs.

MAKE 1975 A BETTER VIEWING YEAR

Improve your colour and monochrome T.V. reception with a U.H.F. pre-amplifier of the type supplied to the trade. We manufacture amplifiers of the following types:

Group	Channel	Typical Gain
A	21-34	18dB
B	39-51	16dB
C/D	49-68	14dB
Wide Band	21-68	10dB

All the above units are supplied complete with an attractive mains power unit at the competitive price of £8.40 (U.K. only), VAT, post and packing inc. Trade enquiries welcome. For details of aerials and aerial accessories send S.A.E. Order direct from:

IMPACT ELECTRONICS,
Unit 16, Stortforth Lane Trading Estate,
Chesterfield, Derbyshire S41 0QQ

VALVES, TRANSISTORS, STYLI. Valves 1930 to 1975. 1500 types. Many obsolete. List 15p. Transistors list 15p. Diamond Styli list 10p. SAE for quotation. Cox Radio (Sussex) Ltd., The Parade, East Wittering, Sussex, West Wittering 2023.

Top 20 Plus Electronically Tested TV Valves

PL504	18p	30FL1/2	15p
PCF801	15p	PCL84	10p
DY86/7	15p	PCL82	10p
PL36	15p	PD500/A	50p
PC88	15p	ECC82	10p
PC86	15p	EH90	10p
PC97	15p	EY86	15p
PCL805/85	15p		

Colour Valves Fully Tested
PL509 40p PY500/A 30p
PL508 30p GY501 50p
PL802 40p PCF802 15p

Many others available including Mazda Types.

P. & P. 4p per valve, over 12 2½p per valve, orders over £4 post free. Prompt service. S.A.E. for New free list

Mail order only.

L. & D. COMPONENTS LTD.

71 Westbury Ave., London N22 6SA.
Tel. 01-888 2701.

MAINS DROPPERS.

37-31-97-26-168 Ω 50p.
25-35-97-59-30 Ω 50p.
14-26-97-160 Ω 50p.
14-26-97-173 Ω 50p.
15-19-20-70-63-28-63 Ω 50p.
Post free. C.W.O.

Durham Supplies, 367 Kensington Street, Bradford, 8, Yorkshire.

VALVE LIST

ALL VALVES FULLY TESTED

One valve postage 4p. Over 5 valves postage paid.

DY86/7	15p	PC900	8p	PCL85	20p
DY802	20p	PC904	8p	PFL200	25p
EB91	12p	PC909	8p	PL36	25p
ECC82	10p	PC9189	8p	PL504	25p
ECL80	8p	PC9803	15p	PV81/800	15p
EP90	8p	PC985	20p	PY801	20p
EP183	10p	PCF80	8p	U191	18p
EP184	10p	PCF86	13p	6P23	15p
EH90	10p	PCF805	20p	6/30L2	15p
EY86/87	13p	PCL82	13p	30F5	10p
PC86	15p	PCL83	13p	30FL1	20p
PC88	15p	PCL84	13p	30PL1	20p

AND MANY MORE AVAILABLE

S. W. ELECTRONICS

114 Burnley Road, Rawtenstall
Rossendale, Lancs.

FOR SALE

PROJECTION T.V.—Rare Decca 1000, complete receiver, optical system gives 4ft. x 3ft. picture. A collectors item in working order. Ring Orpington 59268 for details.

TELEVISION Colour Project, complete set of parts, panels built, I.F. TELEVISION aligned, latest mains transformer, new 26" tube, appropriate TELEVISION issues, must sell, any reasonable offer. Box No. 123.

BOOKS & PUBLICATIONS

YOU NEED

COMPREHENSIVE TV REPAIR MANUALS

by J. McCourt.

- COLOUR TV VOL 1. British models to end 1973, except IIT/KB.
- COLOUR TV VOL 2. IIT/KB to 1973 plus Foreign: includes Sony, Nordmende, etc.
- COLOUR TV VOL 3. Expansion of Vol 1 plus British models to end 1974.
- COLOUR TV VOL 4. Expansion of Vol 1 plus remaining British models to end 1974.
- MONO TV VOL 1. British sets to end 1973, covering from Alba to Ultra.
- MONO TV VOL 2. All Philips, Pye, Ekco and RBM models to end 1973.
- MONO TV VOL 3. Main British and Foreign portables used in UK.
- MONO TV VOL 4. British models released during 1973/74.

Full money back assurance. Thousands of faults—hundreds of models. All written in a practical, easy to follow symptom, cause and cure style. Invaluable to amateurs and students as well as practising engineers. Written for minimum use of Instrumentation. £3.00 each (p. & p. 35p under 4 copies).

BELL'S TELEVISION SERVICES

106, KING'S ROAD, HARROGATE, YORKSHIRE. Telephone: 8423-5888

WANTED

NEW VALVES (pref BVA) of popular types, PCL805, PFL200, PL504 etc. Cash waiting. Bearman, 6 Potters Road, New Barnet, Herts. Tel: 449/1934-5.

TOP PRICES PAID for NEW VALVES and TRANSISTORS

popular T.V. and Radio types
KENSINGTON SUPPLIES (A)
367 Kensington Street, Bradford 8,
Yorkshire.

"RADIO & TV SERVICING" Books wanted from 1961 onwards. Any quantity. £2.00 paid per copy by return of post—Bell's Television Services, 190 Kings Road, Harrogate, Yorks. Tel. (0423) 55885.

SERVICE SHEETS

**BELL'S
TELEVISION
SERVICES**

SERVICE SHEETS • MANUALS • BOOKS

SERVICE SHEETS 50p plus S.A.E. ★ SERVICE SHEET CATALOGUE 25p
OVER 12,000 SERVICE SHEETS & MANUALS IN STOCK ON COLOUR/MONO TELEVISIONS
RADIOS, RADIOGRAMS, T/RECORDERS, R/PLAYERS, ETC. S.A.E. WITH ENQUIRIES

Send large S.A.E. for FREE booklists.

NEW BOOKS & PUBLICATIONS post paid UK only

TV FAULT FINDING BOOK by Data Publications Ltd. 5th Edn. £1.04
RECEIVING PAL COLOUR TELEVISION by A.G.Priestley £5.25
COLOUR TV With Particular Reference to the PAL System by G.N.Patchett. 3rd Edn. £5.15
MAZDA BOOK OF PAL RECEIVER SERVICING by D.J.Seal £5.10
COLOUR TELEVISION PICTURE FAULTS by K.J.Bohlman £2.70
COLOUR TELEVISION THEORY by G.H.Hutson £4.40
COLOUR TELEVISION SERVICING by G.J.King. 2nd Edn. £4.70
NEWNES COLOUR TV SERVICING MANUAL. VOLUME ONE by G.J.King £5.25
NEWNES COLOUR TV SERVICING MANUAL. VOLUME TWO by G.J.King £5.25
TELEVISION SERVICING HANDBOOK 3rd Edn. by G.J.King £4.10
SERVICING WITH THE OSCILLOSCOPE by G.J.King £2.05
BEGINNER'S GUIDE TO COLOUR TELEVISION 2nd Edn. by G.J.King £2.10
BEGINNER'S GUIDE TO TELEVISION 5th Edn. by G.J.King £1.75
BEGINNER'S GUIDE TO ELECTRONICS by Squires & Deason. 3rd Edn. £2.07
TRANSISTOR AUDIO & RADIO CIRCUITS by Mullard Ltd. 2nd Edn. £2.05
TV TECHNICIANS BENCH MANUAL by G.R.Wilding £2.75
RADIO TECHNICIANS BENCH MANUAL by H.W.Hollyer £3.20
AUDIO TECHNICIANS BENCH MANUAL by John Earl £3.20
Mechanics Course in Radio TV & Electronics 222 (433) by B.Fozard & G.N.Patchett
PRINCIPLES & CALCULATIONS (FIRST YEAR) B.Fozard £0.65
PRINCIPLES & CALCULATIONS (SECOND & THIRD YEARS) B.Fozard £1.35
ELECTRONIC SYSTEMS (PART 1. FIRST YEAR) G.N.Patchett £1.05
ELECTRONIC SYSTEMS (PART 2. SECOND YEAR) G.N.Patchett £1.15
ELECTRONIC SYSTEMS (PART 2. THIRD YEAR) G.N.Patchett £2.25
TELEVISION (COLOUR & MONOCHROME PART 3.) G.N.Patchett £2.70

"RADIO & TELEVISION SERVICING" books bought and sold, from Volume 1 up to 1973-1974 edition.
Back issues of PW. PE. EE. TV. E-Today & Constructor available, cover price plus 7p postage per copy.
OPEN UNTIL 6pm DAILY & 8pm SATURDAY. CALLERS WELCOME TO COME AND BROWSE.

B.T.S (Mail Order Dept.) 190, KINGS ROAD, HARROGATE, YORKS. Tel. 55885

**LARGE SUPPLIER
OF
SERVICE SHEETS**

All at 50p each
(T.V., RADIO, TAPE RECORDERS,
RECORD PLAYERS, TRANSISTORS,
STEREOGRAMS, RADIOGRAMS,
CAR RADIOS)

**"PLEASE ENCLOSE LARGE S.A.E.
WITH ALL ENQUIRIES & ORDERS"**

Otherwise cannot be attended to

(Uncrossed P.O.'s please, original
returned if service sheets not available.)

PLEASE NOTE

We operate a "by return of post" service. Any
claims for non-delivery should be made within
7-days of posting your order.

**C. CARANNA
71 BEAUFORT PARK
LONDON, NW11 6BX**

We have the largest supplies of Service
Sheets (strictly by return of post). Please
state make and model number alternative.
Free T.V. fault tracing chart or T.V. list on
request with order.

Mail order or phone 01-458 4882

LADDERS

ALUMINIUM cat ladders. 12ft-24ft. Tel:
Telford 586644 (after 5 p.m.: 0932-586131).
Also manufacture Alloy Ext. up to 62ft.
Catalogues.

'CAUSE & CURE' T.V. Manuals. Invaluable
for professional and amateur. SAE details:
Colis, 33 Maple Avenue, Morecambe,
LA3 1HZ, Lancs.

SERVICE SHEETS, Radio, TV etc. 8,000
models. Catalogue 20p. S.A.E. enquiries.
Telray, 11 Maudland Bank, Preston.

EDUCATIONAL

**TELEVISION
TRAINING**

16 MONTHS' full-time practical and
theoretical training course in Radio &
TV Servicing (Mono & Colour) for
beginners.

13 WEEKS' full-time Colour TV Ser-
vicing course. Includes 100 hours prac-
tical training. Mono revision if necessary.
Good electronics background essential.

NEXT SESSION commences on
April 21st.

PROSPECTUS FROM:
London Electronics College, Dept. TT4
20 Penywern Road, London SW5 9SU.
Tel. 01-373 8721.

C AND G EXAMS

Make sure you succeed with an ICS home
study course for C and G Electrical Install-
ation Work and Technicians, Radio/TV/
Electronics Technicians. Telecomm
Technicians and Radio Amateurs.

COLOUR TV SERVICING

Make the most of the current boom! Learn
the techniques of servicing Colour and
Mono TV sets through new home study
courses, approved by leading manufacturers

TECHNICAL TRAINING

Home study courses in Electronics and Elec-
trical Engineering, Maintenance, Radio,
TV, Audio, Computer Engineering and
Programming. Also self-build radio kits. Get
the qualifications you need to succeed.

Free details from:

**INTERNATIONAL
CORRESPONDENCE SCHOOLS**
Dept 750, Intertext House, London SW8 4UJ
Or Phone 01-422 9911 (All Hours)

SITUATIONS VACANT

TELEVISION ENGINEER Required, for
independent Company in West London. Must
be fully experienced with Monochrome and
Colour TV's. Able to drive. Top salary paid
for the right applicant. Please contact Mrs
Gostelow on 01-603 8488 for interview.

MISCELLANEOUS

NEWNES RADIO and TV Servicing. Buying 1963-74 £2.50 each. Selling most years. Television Magazine buying/selling, S.A.E. lists. Derwent Radio, 5 Columbus Ravine, Scarborough.

Build the Mullard C.C.T.V. Camera

Kits are now available with comprehensive construction manual (also available separately at 80p)

Send 5" x 7" S.A.E. for details to

CROFTON ELECTRONICS

124 Colne Road, Twickenham, Middlesex TW2 6QS

LOWEST COST IC SOCKETS. Use Solder-con IC socket pins for 8 to 40 pin DIL's. 70p for strip of 100 pins, £1.50 for 3 x 100, £4 for 1,000. 10p p & p for orders under £2. Add 8% VAT. Instructions supplied—send SAE for sample. SINTEL, 53d Aston Street, Oxford. Tel: 0865 43203.

A GOOD COLOUR SET REQUIRES GOOD GREY-SCALE TRACKING—

Our Grey Scale Generator module produces 8 bars in true monochrome! Achieve superb tracking in seconds—save time and money! Kit of all electronic components incl. drilled P.C. board, instructions etc., only £7.35 inclusive. (C.W.O., Mail Order only)

TECHNALOGICS

45 Rosemount, Birkenhead, Merseyside L43 5SQ

AERIALS

DX/TV aerials, Band I—£5. Band III—£3. Details. Cook, 90 Ewhurst Road, Crawley 23885, Sussex.

J. & A. Tweedy (Electronic Supplies) Ltd.
We stock the full range of Jaybeam FM and TV aerials of which most are in stock at the time of going to print.
Multibeam: MBM 28 £5.00, MBM 48 £8.00, MBM 70 £12.00, Parabeam: JBM 18 £4.00, Stereobeam: SBM 2 £3.00, SBM 3 £4.00, SBM 4 £5.00, SBM 6 £8.00, FM95 £19.00. Masthead UHF Amplifiers: complete with power unit £11.00. Serbeck £5.50. Low loss coax 12p/m. Rotators by CDE AR 30 £27.00, AR 40 £32.00. The AR30 will take small VHF aerials and UHF TV aerials but if you require to put two or more aerials on the rotor the AR 40 will do the job. For that large array we can supply the CD 44 at £64.00. Towers 20ft., 40ft. and 60ft. available—ask for free quote. ACCESS CARDS WELCOME
79 Chatsworth Road, Chesterfield S402AP Tel: 34982

FANTASTIC BARGAINS

J BEAM CARAVAN AERIAL KIT

Rec. Retail £12.65

OUR PRICE £10.89

Complete with Mast Coaxial Cable Plug, and fixing bracket.

TELEVISION SET TOP AERIALS

Star Beam 4 element for 625 reception **£2.40**

Top-Log Periodic for 625 reception **£3.40.**

MULTIBEAM UHF AERIALS

MBM 28 £5.00 MBM 48 £7.98

MBM 88 £16.48

PARABEAM UHF AERIALS

PBM 10 £3.45 PBM 18 £5.00

VHF/FM STEREO AERIALS

SBM 2 £3.60 SBM 3 £5.30

SBM 4 £5.80 SBM 6 £8.60

Mast Head UHF Amplifiers with mains power supply **£9.95**

Low Loss Coaxial Cable 12p per metre
Aerial Plugs 12p each

SEND CWO TO:

HEATEX ELECTRONICS

101 ROCKINGHAM ROAD, CORBY, NORTHANTS

Please add 50p pp.

WRIGHT'S AERIALS

UHF aerials: all Jaybeam and Antiference products. Antiference Trucolour—TC10 £4.00, TC18 £5.30, Jaybeam High Gain—MBM 30 £5.15, MBM 46 £8.00, MBM 70 £13.75, Antiference Extra Gain—XG8 £7.90, XG14 £14.00, XG21 £19.00. Please state transmitter or channel group if known. Labgear UHF masthead amplifiers—CM6000 (grouped) £11.05, CM6019 (wideband) £10.25. Both with mains power supply. Coax: semi air-spaced low-loss 12 p/yd. Prices include VAT and mainland postage. VHF-DX, etc: you can build really professional VHF aerials from our range of quality components. Designs supplied. Also ready-built to your spec. Band III high gain: Jaybeam and Antiference. Large SAE for list and details, indicating particular interest please. Individual advice supplied with order if requested.
Dept. 1, 3 Cheltenham Rise, Scawsby, Doncaster, S. Yorks.

COLOUR TV's

Bush 25" tube } Always in stock.
GEC 19" tube } Many other makes. Working sets from £75.
Baird 25" tube } Plenty of non-workers.

Large variety of B/W TV's in stock, working and non-working at competitive prices. Untested sets from 50p to callers.

Trade welcome, open all week except Wednesday p.m.

COLORCARE T.V.

1532 Pershore Road, Stirchley
BIRMINGHAM B30 2NW

(Main A441 road from City centre)

PHILIP H. BEARMAN

6 POTTERS ROAD, NEW BARNET, HERTS.

We offer one of the finest range of new or rebuilt tubes in the country; tubes tested before despatch and usually ex stock and despatched daily securely packed. Deliveries arranged World Wide, prices on application.

Colour tubes, 4 year g'tee.

17" 20" 90° types

A49/11X, A49/120X **£54.00 + cge**

and A49/191X

A51/110X and **£55.00 + cge**

20" 510CKB22

22" A55/14X, **£58.00 + cge**

A56/120X-140X

25" A63/11X, A63/120X **£66.00 + cge**

and A63/200X

26" A66/120X & **£66.00 + cge**

A67/120X

Note. 1 year g'tee **£50.00 + cge**

20" colour

22" Mullard A56/120X **£53.00 + cge**

26" Mullard A66/120X & 140X

£60.00 to £70.00 + cge

25" Mullard A63/11-120X

(when available) **£54.00 + cge**

We often have Mullard 22"/26"

electrically perfect with fractional

marks from £42.00 upwards, avail-

ability etc. on application, also 20"

2nds. Excellent value, g'teed.

Colour cge £2.00 (sea journeys 99p

extra).

TEL. 449-1934/5

NOTE. All prices subject to fluctuations when due to circumstances beyond our control.

STOP PRESS. Philips A28/14W **£12.50 + 75p cge.**

MONO Tubes, usually 2 year g'tee.

TSD217/282 (1 year) **£13.50 + 54p cge**

Cathodeon MW31/74 **£3.24 + 54p cge**

TSD290/CME1201 **£10.80 + 54p cge**

CME1202 **£10.80 + 54p cge**

CME1220/A31-120W **£11.34 + 54p cge**

CME1402/AW36-80 **£5.13 + 59p cge**

MW36/24-44 **£5.13 + 59p cge**

CME1601 **£10.26 + 59p cge**

CME1602 **£11.34 + 59p cge**

CME1713 (A44/120W) **£14.00 + 59p cge**

Other 17" tubes **£6.35 + 59p cge**

A47/11, 26W (CME1913) **£13.65 + 64p cge**

A47/14W-CME1908 **£10.80 + 64p cge**

A47/13W (CME1906) **£13.50 + 64p cge**

A50/120 (CME2013) **£12.28 + 64p cge**

A50/120 rebuilds **£10.45 + 64p cge**

A59/15W (CME2308) **£10.80 + 70p cge**

Rebuilds on application.

A59/11W-A59/23W New **£15.22 + 70p cge**

A59/13W (CME2306) ,, **£15.20 + 70p cge**

A61/120 (CME2413) ,, **£16.20 + 70p cge**

TV'S! TV'S! TV'S!

High Quality Ex-Rental mono and colour
THOUSANDS TO CHOOSE FROM

19"/23" MONO
With valve UHF tuner from £2
(Thorn 850, GEC 1000, Bush 135, KB QV)
with transistorised UHF tuner from £5
(GEC 2018, Philips 70, Bush 141, Thorn 950)
with integrated UHF tuner from £9
(Pye Olympic, Philips 210, Bush 181)

20"/24" MONO
Single and dual standard from £12

19" Colour from £40

25" Colour from £50

22" Colour from £70



Northern 1043 Leeds Road, Bradford 3.
Tel. Bradford (0274) 665670.

Southern Watling Street, Hockliffe
3 miles N. of Dunstable A5.
Tel. Hockliffe 768.

Scotland Peacock Cross Industrial Estate
Burnbank Road, Hamilton.
Tel. (06982) 29511/2

Marshall's

A. Marshall & Son (London) Limited Dept. T
42 Cricklewood Broadway London NW2 3HD Tel: 01-452 0161
& 85 West Regent Street Glasgow G2 2QD Tel: 041-332 4133

Everything you need is in our new 1975 catalogue. Available now price 25p

Trade and export enquiries welcome

PW TELETTENNIS KIT

As featured on B.B.C. Nationwide and in the Daily Mail Oct 2nd 1974

This exciting new game is now available in kit form. Due to popular demand we are now able to offer a fantastic saving on list prices. Ideal game for whole family. No need to modify your TV set, just plugs in to aerial socket.

Parts list as follows . . .

A Resistor Pack	£1.00 p.p. 20p
B Potentiometer Pack	£1.25 p.p. 20p
C Capacitor Pack	£3.10 p.p. 20p
D Semiconductor Pack	£14.50 p.p. 20p
E IC Sockets	£4.00 p.p. 20p
F Transformer	£1.15 p.p. 25p
G PCB's	£7.50 p.p. 20p
H Switches	£4.50 p.p. 20p
I UHF Modulator Kit	£7.20 p.p. 20p

Special Prices—complete kit excluding case £42.00 p.p. 50p. Sections A-F incl. £23.50 p.p. 30p. Assembly instructions with complete kit of 75p on request.

SN7400 16p	SN7420 16p	SN7453 16p	SN7491 £1-10
SN7401 16p	SN7423 37p	SN7454 16p	SN7492 75p
SN7401AN 38p	SN7425 37p	SN7460 16p	SN7493 65p
SN7402 16p	SN7427 45p	SN7470 30p	SN7494 85p
SM403 16p	SN7430 16p	SN7472 38p	SN7495 80p
SN7404 24p	SN7432 45p	SN7473 44p	SN7496 £1-00
SN7405 24p	SN7437 35p	SN7474 48p	SN74100 £2-16
SN7406 45p	SN7438 35p	SN7475 59p	SN74107 43p
SN7407 45p	SN7440 16p	SN7476 45p	SN74118 £1-00
SN7408 25p	SN7441 85p	SN7480 75p	SN74119 £1-92
SN7409 33p	SN7442 85p	SN7481 £1-25	SN74121 57p
SN7410 16p	SN7445 £1-59	SN7482 87p	SN74122 80p
SN7411 25p	SN7446 £2-00	SN7483 £1-20	SN74123 72p
SN7412 28p	SN7447 £1-30	SN7484 95p	SN74141 £1-00
SN7413 50p	SN7448 £1-50	SN7485 £1-58	SN74150 £1-44
SN7416 45p	SN7450 16p	SN7486 45p	SN74190 £1-95
SN7417 30p	SN7451 16p	SN7490 65p	

TRY OUR NEW GLASGOW SHOP

Prices correct at March 1975, but exclusive of VAT. Post and Package 20p postage and package charges.

Popular Semiconductors

2N696 0-22	2N3707 0-13	AD142 0-50	BC309 0-10	LM709T099
2N697 0-16	2N3708 0-70	AD143 0-60	BC327 0-21	0-48
2N698 0-40	2N3715 1-50	AD161 0-45	BC328 0-19	8D1L 0-38
2N699 0-45	2N3716 1-80	AD162 0-45	BCY70 0-17	14D1L 0-40
2N1302 0-19	2N3771 2-20	AD161 pr. 0-77	BCY71 0-22	LM723C 0-90
2N1303 0-19	2N3772 1-80	AD162 1-05	BCY72 0-13	LM741T099
2N1304 0-24	2N3773 2-65	AF109R 0-40	BD123 0-82	0-40
2N1305 0-24	2N3819 0-37	AF115 0-24	BD131 0-40	8D1L 0-38
2N1306 0-31	2N3820 0-38	AF124 0-30	BD132 0-50	14D1L 0-40
2N1307 0-22	2N3823 1-42	AF125 0-30	BD135 0-42	LM747 1-00
2N1308 0-25	2N3904 0-27	AF126 0-28	BD136 0-49	LM7805 2-00
2N1309 0-36	2N3905 0-24	AF127 0-28	BD137 0-55	MC1310 2-92
2N1671 1-44	2N4036 1-63	AF139 0-39	BD138 0-63	MJ480 0-90
2N1671A 1-54	2N4037 0-42	AF178 0-55	BD139 0-71	MJ481 1-14
2N1671B 1-72	2N4126 0-20	AF179 0-65	BD140 0-87	MJ490 0-98
2N1671C 4-32	2N4289 0-34	AF180 0-58	BF115 0-25	MJ491 1-38
2N2102 0-50	2N4921 0-73	AF239 0-51	BF116 0-23	MJE340 0-45
2N2147 0-78	2N4922 0-84	AF240 0-72	BF117 0-43	MJE2955 1-12
2N2148 0-94	2N4923 0-83	AF279 0-54	BF154 0-16	MJE3055 0-68
2N2160 0-60	2N5190 0-92	AF280 0-54	BF163 0-32	MFC4000B 49
2N2218A 0-22	2N5191 0-95	BC107 0-16	BF180 0-35	MFC4010A 49
2N2219 0-26	2N5192 1-24	BC108 0-15	BF181 0-34	MFC40600 54
2N2219A 0-60	2N5195 1-46	BC109 0-19	BF184 0-30	MFC60400 91
2N2221 0-18	2N5245 0-47	BC147 0-12	BF194 0-12	NE555A 0-70
2N2221A 0-21	2N5457 0-49	BC148 0-13	BF195 0-12	NE560D 4-48
2N2222 0-20	2N5458 0-45	BC149 0-12	BF196 0-13	NE561 4-48
2N2222A 0-25	2N5459 0-49	BC167B 0-13	BF197 0-15	NE565A 4-48
2N2646 0-55	40361 0-48	BC168B 0-13	BF198 0-18	OC28 0-76
2N2904 0-22	40362 0-50	BC168C 0-11	BF200 0-40	OC42 0-50
2N2904A 0-24	40363 0-88	BC169B 0-13	BF237 0-22	OC71 0-17
2N2905 0-24	40406 0-44	BC169C 0-13	BF238 0-22	OC72 0-25
2N2905A 0-26	40667 0-00	BC181 0-16	BFX19 0-30	SL414A 1-80
2N2906 0-19	40408 0-50	BC182L 0-12	BFX30 0-27	TA263 1-00
2N2906A 0-21	40409 0-52	BC183 0-12	BFX84 0-24	TBA800 1-50
2N2907 0-22	40410 0-52	BC183L 0-12	BFX85 0-30	TB810 1-50
2N2907A 0-24	40411 2-25	BC184 0-13	BFX87 0-28	TIP29A 0-48
2N2926 0-11	40602 0-46	BC184L 0-13	BFX88 0-25	TIP30A 0-59
2N3053 0-32	40604 0-56	BC212K 0-16	BFX89 0-90	TIP31A 0-62
2N3054 0-60	40607 0-00	BC212L 0-16	BFY19 0-62	TIP228 0-74
2N3055 0-75	AC117 0-20	BC214L 0-21	BFY51 0-23	TIP33A 1-01
2N3441 0-97	AC126 0-20	BC237 0-13	BFY52 0-21	TIP34A 1-51
2N3442 1-69	AC127 0-20	BC238 0-13	BFY90 0-60	TIP35A 2-90
2N3415 0-10	AC128 0-20	BC239 0-13	BRY39 0-48	TIP36A 3-70
2N3416 0-15	AC151V 0-26	BC257 0-14	CO160 0-65	TIP41A 0-79
2N3417 0-21	AC152V 0-17	BC258 0-13	CA3020A1-80	TIP42A 0-90
2N3702 0-11	AC153K 0-25	BC259 0-14	CA3046 0-70	TIP225 0-93
2N3703 0-12	AC176 0-18	BC300 0-36	CA3048 2-11	TIP3055 0-60
2N3704 0-14	AC176K 0-25	BC301 0-34	CA3089E1-96	ZTX 300 0.13
2N3705 0-12	AC187K 0-23	BC307 0-11	CA3090 4-23	ZTX 302 0.20
2N3706 0-09	AC188K 0-34	BC308 0-12	LM301A 0-46	ZTX 500 0.15



"I MADE IT MYSELF"

Imagine the thrill you'll feel! Imagine how impressed people will be when they're hearing a programme on a modern radio you made yourself.

Now! Learn the secrets of radio and electronics by building your own modern transistor radio!

Practical lessons teach you sooner than you would dream possible.

What a wonderful way to learn—and pave the way to a new, better-paid career! No dreary ploughing through page after page of dull facts and figures. With this fascinating Technatron Course, you learn by building!

You build a modern Transistor Radio . . . a Burglar Alarm. You learn Radio and Electronics by doing actual projects you enjoy—making things with your own hands that you'll be proud to own! No wonder it's so fast and easy to learn this way. Because learning becomes a hobby! And what a profitable hobby. Because opportunities in the field of Radio and Electronics are growing faster than they can find people to fill the jobs!

So fast, so easy, this personalised course will teach you even if you don't know a thing today!

No matter how little you know now, no matter what your background or education, we'll teach you. Step by step, in simple easy-to-understand language, you pick up the secrets of radio and electronics.

You become a man who makes things, not just another of the millions who don't understand. And you could pave the way to a great new career, to add to the thrill and pride you receive when you look at what you have achieved. Within weeks you could hold in your hand your own transistor radio. And after the course you can go on to acquire high-powered technical qualifications, because our famous courses go right up to City & Guilds levels.

No soldering—yet you learn faster than you ever dreamed possible.

Yes! Faster than you can imagine, you pick up the technical know how you need. Specially prepared step-by-step lessons show you how to: read circuits—assemble components—build things—experiment. You enjoy every minute of it!

You get everything you need. Tools. Components. Even a versatile Multimeter that we teach you how to use. All included in the course AT NO EXTRA CHARGE! And this is a course anyone can afford.

Send now for FREE 76 page book—see how easy it is—read what others say!

Find out more now! This is the gateway to a thrilling new career, or a wonderful hobby you'll enjoy for years. Send the coupon now. There's no obligation.

POST TODAY FOR FREE BOOK

To: ALDERMSTON COLLEGE
DEPT. CTV04
READING RG7 4PF

CTV04

Yes, I'd like to know more about your course. Please send me free details—plus your big, 76-page book that tells about all your courses.

NAME _____

ADDRESS _____

POST CODE _____

BIET

HOME OF BRITISH INSTITUTE OF ENGINEERING TECHNOLOGY

TELEVISION TUBE SHOP

NEW TUBES AT CUT PRICES

A28-14W Equivalent	£12.50
A47-11W/A47-18W	£11.00
A47-26W	£13.50
AW47-91/CME1903	£9.50
AW59-91/CME2303	£12.00
CME1201/A31-18W	£13.50
CME1202/A31-181W	£13.50
CME1220/A31-120W	£14.95
CME1420/A34-100W	£13.50
CME1520/A38-160W	£16.50
CME1601/A40-11W	£12.50
CME1602/A40-12W	£13.50
CME1713/A44-120	£17.50
CME1906/A47-13W	£12.50*
CME1905/CME1907	£9.50*
CME1908/A47-14W	£9.50
CME2013/A50-120	£12.95
CME2306/A59-13W	£13.50*
CME2308/A59-15W	£12.00
CME2313/A59-23W	£14.50
CME2413/A61-120W	£16.50
TSD217/TSD282	£7.50

JAPANESE/USA TUBES

190AB4	7"	£9.50
230AB4	9"	£9.50
230DB4/CT468	9"	£11.50
280TB4	11"	£9.95
CT507	11"	£9.95
310DMB4	12½"	£11.50
310DGB4	21½"	£11.50
340AB4	14"	£15.50
340RB4	14"	£15.50

*Types marked thus are fully rebuilt

NEW COLOUR TUBES

A49-191X/120X	£45.00
A56-120X	£60.00
A63-120X	£68.00
A66-120X	£75.00

NEW SCRATCHED COLOUR TUBES

20", 22", 26" from £35

All tubes guaranteed for 12 months

Carriage/insurance £1 mono, £1.50 colour

Add 8% VAT to all prices

TELEVISION TUBE SHOP

46/48 BATTERSEA BRIDGE RD
LONDON SW11 228-6859

WE GIVE GREEN SHIELD STAMPS

SOUTHERN VALVE COMPANY

P.O. Box 144, BARNET, Herts.

Telephone: 01-440 8641. Mail order only. Most leading makes. (subject to availability)

AZ31	62p	EM84	42p	PCL83	48p	UCL82	40p	30L1	38p
DY86/7	35p	EY51	45p	PCL84	45p	UCL83	55p	30L5	75p
DY802	40p	EY86/7	35p	PCL85	55p	UF41	65p	30L17	70p
EB91	18p	EZ40/1	48p	PCL805	55p	UF89	40p	30P12	75p
ECC81	34p	EZ80	33p	PCL86	48p	UL41	70p	30P19	70p
ECC82	32p	EZ81	28p	PD500	£1.60	UL84	42p	30PL1	80p
ECC83	32p	GY501	75p	PFL200	70p	UY41	44p	30PL13	75p
ECC85	38p	GZ30	44p	PL36	58p	UY85	32p	30PL14	80p
ECC88	45p	PC86	61p	PL81	48p	U25	70p	30PL15	80p
ECH42	70p	PC88	61p	PL81A	52p	U26	66p	30P4MR	90p
ECH81	34p	PC97	38p	PL82	37p	U191	70p		
ECH84	50p	PC900	47p	PL83	44p	6/30L2	70p		
ECL80	50p	PCC84	38p	PL84	45p	6BW7	65p		
ECL82	44p	PCC85	42p	PL500	72p	6F23	70p		
ECL83	65p	PCC88	60p	PL504	67p	6F28	65p		
ECL86	40p	PC89	48p	PL508	80p	6V6	45p		
EF80	28p	PCC189	50p	PL509	£1.45	6X4	38p		
EF85	36p	PCF80	38p	PL802	90p	6X5	44p		
EF86	50p	PCF82	48p	PY33	50p	10F1	65p		
EF89	30p	PCF86	55p	PY81/3	33p	20L1	80p		
EF183	35p	PCF200	85p	PY88	39p	20P4	85p		
EF184	35p	PCF801	48p	PY800	39p	30C1	75p		
EH90	53p	PCF802	48p	PY801	39p	30C15	75p		
EL34	55p	PCF805	75p	PY500A	90p	30C17	77p		
EL41	55p	PCF806	52p	UBF89	38p	30C18	75p		
EL84	33p	PCF808	75p	UCC85	44p	30F5	75p		
EL90/1	45p	PCH200	75p	UCH42	70p	30FL1	68p		
EM80	45p	PCL82	36p	UCH81	40p	30FL2	68p		

One valve post 6p, each extra valve 5p. LISTS s.a.e. please.

We offer return of post service.

Items in stock at time of going to press but subject to possible market fluctuations if unavoidable.

Post free over £10.

UHF MODULATOR

Which enables the use of a standard TV as a monitor for CCTV and Video games (TV Tennis).

Operates from 8V-12V DC. Tuneable over UHF Channels 27-40. Input—Standard IV pos. Video.

Output—7.5mV into 75ohm at 600MHZ.

Dimensions: 2½" x 2" x ½" — 6' coax.

Price—Fully Assembled and Tested £6.50 inc. VAT and postage.

Please send cheque or P.O. with order to:

STRONG ELECTRONICS LIMITED
Bourne Works, Whyteleafe, Surrey CR3 0YD

PHILIP H. BEARMAN

(VALVE SPECIALISTS) SUPPLIERS TO H.M. GOVT. Etc.

NEW valves by Mullard, Mazda, Telefunken, Tungram

IMMEDIATE POSTAL DESPATCH, LISTS S.A.E., DISCOUNT PRICES

ALL PRICES SUBJECT TO ALTERATION WITHOUT NOTICE.

PRICES FROM MARCH 1975 (INCL. V.A.T. @ CURRENT RATE)

DY86/7	38p	PCC84	40p	PD500	£1.60	6F23	80p	ENQUIRIES
DY802	42p	PCC89	52p	PFL200	74p	6F28	67p	WELCOMED
ECC81	38p	PCC189	58p	PL36	80p	20P4	88p	ON
ECC82	40p	PCF80	47p	PL84	60p	30C1	47p	OUR
ECL80	60p	PCF86	62p	PL504	77p	30C17	84p	FAST
EF80	37p	PCF200	84p	PL509	£1.45	30FL1	67p	RANGE
EF183	54p	PCF801	52p	PL802	£1.20	30FL2	67p	
EF184	54p	PCF802	64p	PY81	40p	30L15	86p	
EH90	56p	PCF805	83p	PY800	45p	30L17	86p	
EY51	66p	PCF808	78p	PY801	45p	30P12	87p	
EY86/7	34p	PCH200	96p	PY500(A)	98p	30PL1	87p	
GY501	70p	PCL82	47p	U25	80p	30PL13	95p	
PC86	72p	PCL83	52p	U26	80p	30PL14	£1.10	
PC88	72p	PCL84	46p	6/30L2	80p	30PL15	94p	
PC97	38p	PCL805/85	58p	6BW7	74p	ETC., ETC.		
		PCL86	58p					

See separate Component, CRT and Transistor Lists. Many obsolete types available, SAE with enquiries please. Please verify current prices

Overseas Post @ Cost. J.K. 6p per valve for one, and others 5p. Post free over £8.00.

(Adjacent to Post Office) **6 POTTERS RD., NEW BARNET**
HERTS. Tel: 449/1934-5 any time.

STOP PRESS. PC92/96, PL95, PL519 available!

TV LINE OUTPUT TRANSFORMERS

ALL MAKES SUPPLIED PROMPTLY by our
RETURN OF POST MAIL ORDER SERVICE

All Lopts at the one price

£4.86 TRADE £5.40 RETAIL (V.A.T. INCLUDED)

Except

BUSH MODELS TV53 to TV101.

EKCO MODELS TC208 to TV417.

FERGUSON MODELS 305 to 438, 506 to 546.

FERRANTI MODELS 1084 to 1092.

Post and Packing 30p COD 33p

HMV MODELS 1876 to 1878, 1890 to 1896, FR 20.

MURPHY MODELS V280 to V330, V420, V440, 653X to 789 OIL-FILLED.

REGENTONE MODELS 10-4 to 10-21, 1718, R2, R3, 191, 192.

RGD 519-621, 710, 711.

ALL AT £2.70 + 30p P&P

EHT TRAYS SUPPLIED—MONO & COL.

All Lopts NEW and GUARANTEED for SIX MONTHS

E. J. PAPWORTH AND SON Ltd.,
 80 MERTON HIGH ST., LONDON, S.W.19

01-540 3955

01-540 3513

THE UM4 "COLOURBOOSTER" UHF/625 LINE

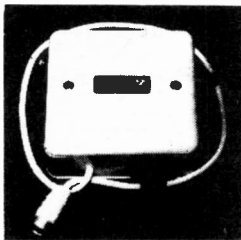

CAN PRODUCE
 REMARKABLE
 IMPROVEMENTS IN
 COLOUR AND
 PICTURE QUALITY
 IN FRINGE OR
 DIFFICULT AREAS
 WITH SIGNIFICANT
 REDUCTION IN
 NOISE (SNOW).

HIGH GAIN—VERY LOW NOISE
 FITTED FLY LEAD—INSTALLED IN SECONDS
 HIGHEST QUALITY COMPONENTS
 IVORY PLASTIC CASE $3\frac{1}{2} \times 3\frac{1}{2} \times 1\frac{1}{2}$ CORK BASE
 CHANNELS: Group A, Red code 21-33
 Group B, Yellow code 39-51
 Group C-D, Green code 52-68

EQUALLY SUITABLE FOR BLACK AND WHITE

Also the M4 DUAL BAND VHF UNIT

BOOSTS ALL BAND III and ANY SPECIFIED
 BAND I CHANNEL SIMULTANEOUSLY
 NOMINAL GAIN 16-18 DB BOTH BANDS

PRICES BOTH TYPES:

Battery model £4.17 Mains version £6.50

Including VAT p/p 27p

TRANSISTOR DEVICES LIMITED
 6 ORCHARD GDNS., TEIGNMOUTH, DEVON
 Telephone: Teignmouth 4757

VALVE BARGAINS

Any 5 50p, 10 75p, 50
 £3.30, 100 £6.40. Your
 choice from the fol-
 lowing list:

ECC82, ECL80, EB91, EF80,
 EF183, EF184, PC86, PC88,
 PC97, PC900, PCC84, PCC89,
 PCC189, PCF80, PCF802,
 PCF805, PCL82, PCL84, PCL85,
 PCL805, PCL86, PFL200, PL36,
 PL504, PY33, PY81, PY800,
 PY88, EH90, 30FL1, 30FL2,
 30PL14.

Colour Valves 25p each
 PL508, PL509, PY500/A

Press 4 Button UHF
 Tuners £2.50.

AERIAL BOOSTERS

We make three types of
 Aerial Boosters all for
 set-top fitting, with Co-
 ax Plugs and Sockets.

B11—For Stereo and
 Standard VHF Radio
B12—For the older
 VHF Television,
 please state BBC1
 and ITV Channels.

B45—For mon. or
 colour this covers the
 complete UHF band.

All Boosters are complete
 with Battery and take only
 minutes to fit.

Price £3.40 each

BARGAIN PACKS

All Components in the Bargain Packs are unused and marked.

Pack 1—Polyester (C280) Axial Leads Capacitors
 —250V/W & 400V/W, very good mixed selection
 from 0.01 UF to 2.2 UF. Price 100 £1, 1000 £8 (our
 choice).

Pack 2—Electrolytic Capacitors—good mix
 selection from 1 UF to 1000 UF, and from 10V/W to
 63V/W. Price 100 £1.50, 500 £6 (our choice).

Pack 3—Transistors—any 10 80p, any 100 £7
 (your choice). AC128 - AC176 - BC113 - BC115 -
 BC135 - BC153 - BC171 - BC172.

Pack 4—15 Mixed Plugs, mixed selection of co-ax,
 din 2-3-5 pins, jack standard—3.5mm - 2.5mm. £1.

Prices include V.A.T. P. & P. under £1/10p, £1 to £3/15p, over 20p.
 Overseas at cost. Money back refund on all orders.

ELECTRONIC MAILORDER LTD., 62 BRIDGE STREET,
 RAMSBOTTOM, BURY, LANCS. Tel. Ramsbottom 3036.

Radio/TV repairs news flash



“Here is the SCS news. We can offer you a truly complete, professional service for top quality, guaranteed components. We are franchised to distribute Mullard components and Motorola, Ferranti, Signetics, G.I. and Monsanto, too.

Not only do you get the best components, but our prices and services are unequalled. You can either call in to our trade counter for a take-away service backed by any technical advice you may need, or you can simply send cash with your order. Regular customers can even apply for credit terms. Our price list will show you just how competitive we are. Try us; we think you'll notice the difference.”



SCS Components,
Northfield Industrial Estate, Beresford Avenue,
Wembley, Middlesex HA0 1SD Tel: 01-903 3168

THE FORGESTONE 400 a high quality colour television receiver.

A really up-to-the-minute kit
with all these plus features . . .

9 integrated circuits	Thick film resistor units
Ready-built and aligned I F module	Glass epoxy printed circuit panels
High quality components	Fully isolated power supply
Plugs and sockets for easy panel removal	Each module kit available separately
Full technical construction manual	LT supply regulators

Send for further details of the Forgestone 400 . . .
the quality kit for the constructor of today.

Forgestone Colour Developments Ltd.

Ketteringham, Wymondham, Norfolk
Telephone: Norwich 810453 (STD 0603)

REBUILT TUBES!

YOU'RE SAFE WHEN YOU
BUY FROM RE-VIEW!

HERE IS WHAT YOU PAY:

MONO

15-17"	£5.00
19"	£5.50
21"	£6.50
23"	£7.50

RIMBAND & TWIN PANEL

19"	£7.50
20"	£8.50
23"	£9.50
24"	£10.50
Carriage £1.00	

COLOUR

19"	£26.00
22"	£29.00
25"	£32.00
26"	£35.00

Exchange Basis
(carriage-ins. £2.00)

Guarantee 1 year

Cash or cheque with order, or cash on delivery

RE-VIEW ELECTRONIC TUBES

237 LONDON ROAD,
WEST CROYDON, SURREY
Tel. 01-889 7735

COLOUR TUBES STANDARD TUBES

METAL BAND TUBES

TWIN PANEL TUBES

Rebuilt with new Electron
Guns to British Standard
415/1/1967.

SUFFOLK TUBES LIMITED

261 CHURCH ROAD
MITCHAM, SURREY CR4 3BH
01-640 3133/4/5

Britain's Largest Independent
TV Tube Rebuilder

PLEASE MENTION
TELEVISION
WHEN REPLYING
TO ADVERTISEMENTS

REBUILT COLOUR TUBES ALL SIZES AVAILABLE

Full range of rebuilt mono
tubes available, Standard,
Rimband and Twin Panel.

- ★ Complete new gun fitted to every tube.
- ★ 12 months' guarantee
- ★ 17 years' experience in tube rebuilding.
- ★ Trade enquiries welcomed.

N.G.T. ELECTRONICS LTD.
20, Southbridge Road,
Croydon, Surrey
Telephone: 01-681 7848/9

FREE!

Over 150 ways to engineer a better future



HIGHER PAY **A BETTER JOB**
SECURITY

find out how in just 2 minutes

That's how long it will take you to fill in the coupon. Mail it today and we'll send you full details and a free book. We have successfully trained thousands of men at home—equipped them for higher pay and better, more interesting jobs. We can do as much for YOU. A low-cost home study course gets results fast—makes learning easier and something to look forward to. There are no books to buy and you can pay-as-you-learn.

Why not do the thing that really interests you? Without losing a day's pay, you could quietly turn yourself into something of an expert. Complete the coupon (or write if you prefer not to cut the page). No obligation and nobody will call in on you . . . but it could be the best thing you ever did.

Others have done it, so can you

"Yesterday I received a letter from the Institution informing that my application for Associate Membership had been approved. I can honestly say that this has been the best value for money I have ever obtained, a view echoed by two colleagues who recently commenced the course". Student D.I.B., Yorks.

"Completing your course, meant going from a job I detested to a job that I love, with unlimited prospects"—Student J.A.O. Dublin.

"My training quickly changed my earning capacity and, in the next few years, my earnings increased fourfold". Student C.C.P., Bucks.

FIND OUT FOR YOURSELF

These letters and there are many more on file at Aldermaston College, speak of the rewards that come to the man who has given himself the specialised know-how employers seek. There's no surer way of getting ahead or of opening up new opportunities for yourself. It will cost you a stamp to find out how we can help you. Write to:

Aldermaston College

Dept. TTV04, Reading RG7 4PF

HOME OF BRITISH INSTITUTE OF ENGINEERING TECHNOLOGY

Practical Radio & Electronics Certificate course includes a learn while you build **3 transistor radio kit.** Everything you need to know about **Radio & Electronics** maintenance and repairs for a **spare time income** and a **career** for a better future.



CUT OUT THIS COUPON
 Tick or state subject of interest.
 Post to address below.

<p>MECHANICAL Society of Engineers— A.M.S.E. (Mech) <input type="checkbox"/> Institute of Engineer & Technicians (A.M.I.E.) <input type="checkbox"/> CITY & GUILDS Gen. Mech. Eng. <input type="checkbox"/> Maintenance Eng. <input type="checkbox"/> Welding <input type="checkbox"/> Gen. Diesel Eng. <input type="checkbox"/> Sheet Metal Work <input type="checkbox"/> Eng. Inspection <input type="checkbox"/> Eng. Metallurgy <input type="checkbox"/></p>	<p>DRAUGHTSMANSHIP Institute of Engineering Designers (A.M.I.E.D.) <input type="checkbox"/> General Draughtsmanship <input type="checkbox"/> Elec. Draughtsmanship <input type="checkbox"/> Architectural Draughtsmanship <input type="checkbox"/> Technical Drawing <input type="checkbox"/></p>	<p>Construction Surveyors Institute L.C.S.I. <input type="checkbox"/> City & Guilds General Building (all branches) <input type="checkbox"/> Heating & Vent. Inst. Clerk of Works <input type="checkbox"/> Site Surveying <input type="checkbox"/> Health Engineering <input type="checkbox"/> Road Construction Quantities <input type="checkbox"/> Estimates <input type="checkbox"/> Hydraulics <input type="checkbox"/> Structural Eng. <input type="checkbox"/></p>	
<p>ELECTRICAL & ELECTRONIC CITY & GUILDS Gen. Electrical Engineering <input type="checkbox"/> Electrical Installations <input type="checkbox"/> Electrical Maths <input type="checkbox"/> Computer Electronics <input type="checkbox"/> Electronic Eng. <input type="checkbox"/> Practical Radio & Electronics (with kit) <input type="checkbox"/></p>	<p>RADIO & TELE-COMMUNICATIONS City & Guilds Telecons. <input type="checkbox"/> Gen. Radio & TV Eng. <input type="checkbox"/> Radio Amateurs Exam <input type="checkbox"/> Radio Servicing <input type="checkbox"/></p>	<p>GENERAL Agricultural Eng. <input type="checkbox"/> Council of Eng. Institutions <input type="checkbox"/> Farm Science <input type="checkbox"/> Plastics <input type="checkbox"/></p>	
<p>MANAGEMENT & PRODUCTION Institute of Cost & Management Accts. <input type="checkbox"/> Computer Programming <input type="checkbox"/> Works M'ment <input type="checkbox"/> Work Study <input type="checkbox"/> Gen. Production Eng. <input type="checkbox"/> Estimating & Planning <input type="checkbox"/> Storekeeping <input type="checkbox"/> Management <input type="checkbox"/> Skills <input type="checkbox"/> Quality Control <input type="checkbox"/></p>	<p>AUTOMOBILE & AERONAUTICAL Institute of the Motor Industry A.M.I.I. <input type="checkbox"/> MAA/IMI <input type="checkbox"/> City & Guilds Auto Eng. <input type="checkbox"/> Gen. Auto Eng. <input type="checkbox"/> Motor Mechanics <input type="checkbox"/> Auto Diesel Eng. <input type="checkbox"/> Garage M'ment <input type="checkbox"/> AEC Aero <input type="checkbox"/> Engineering Exams <input type="checkbox"/> Gen. Aero Eng. <input type="checkbox"/></p>	<p>Supplementary courses for Nat. Certificates.</p>	
<p>G.C.E. —choose from 58 'O' & 'A' level subjects</p>			
			<p>Coaching for many exams, including C & G</p>

POST TODAY FOR A BETTER TOMORROW

To Aldermaston College,
 Dept. TTV04 Reading RG7 4PF

NAME.....
 Block capitals please
 ADDRESS.....

 POST CODE.....
 OTHER SUBJECTS.....
 AGE.....
 Accredited by C.A.C.C. Member of A.B.C.C.

130 5002

WITWORTH TRANSFORMERS

MONOCHROME TV Line out-put transformers (Discounts to Trade)

ALL ONE PRICE £5.72 EACH V.A.T. & CARRIAGE PAID (£5.45 PERSONAL SHOPPERS)

BUSH	
TUG versions	TV125
TV75 or C	TV125U
TV76 or C	TV128
TV77	TV134
TV78	TV135
TV79	TV135R
TV83	TV138
TV84	TV138R
TV85	TV139
TV86	TV141
	TV145
TV91	TV148
TV92	TV161
TV93	TV165
TV94	TV166
TV95 or C	TV171
TV96 or C	TV175
TV97	TV176
TV98C	TV178
TV99 or C	1815
TV100C	183
TV101C	183D
TV102C	1835
TV103 or D	1835S
TV105 or D or R	1855
TV106	186
TV107	186D
TV108	1865
TV109	1865S
TV112C	1915
TV113	191D
TV115 or C or R	1935
TV118	193D
TV123	
TV124	

BAIRD			
600	628	662	674
602	630	663	675
604	632	664	676
606	640	665	677
608	642	666	681
610	644	667	682
612	646	668	683
622	648	669	685
624	652	671	687
625	653	672	688
626	661	673	

Please quote part No. normally found on tx. base plate: 4121, 4123, 4140 or 4142.

DECCA				
DR20	DR34	DR71	DR505	
DR21	DM35	DR95	DR606	
DR23	DM36	DR100	666TV-SRG	
DR24	DM39C	DR101	777TV-SRG	
DR29	DR41	DR121		
DR30	DM45	DR122	MS1700	
DM30	DR49C	DR123	MS2000	
DR31	DM55	DR202	MS2001	
DR32	DM56	DR303	MS2400	
DR33	DR61	DR404	MS2401	

SOBELL				
T24	ST284 or ds	1010dst	1033	
SC24	ST285 or ds	1012	1038	
TPS173	ST286 or ds	1013	1039	
TPS180	ST287 or ds	1014	1047	
ST195 or ds	ST288 ds	1018	1048	
ST196 or ds	ST290ds	1019	1057	
ST197ds	ST291ds	1020	1058	
SC270	ST297ds	1021	1063	
T278	1000ds	1022	1064	
ST282	1002ds	1023	1065	
ST283	1005ds	1032	1066	

MURPHY				
V430	V520	V879 or C*	V789	V20155S
V310A	V430C	V923*	V153	V20165
V310AD	V430D	V929 or L*	V159	V20175
V310AL	V430K	V973C*	V173	V2310
V310CA	V440	V979*	V179	V2311C
V320	V440D	V653X	V1910	V2414D
V330 or D	V440K	V659	V1913	V2415D
V330F or L	V470	V649D	V1914	V2415S
V410	V480	TM2 Chassis	V739	V2014
V410C	V490	V843*	V735	V2014S
V410K	V500	V849*	V783	V2015D
V420	V510	V873*	V787	V2015S
V420K	V519			V24175

PHILIPS			
23TG111a	G19T210	G23T210	
23TG113a	G19T211	G23T211	
23TG121a	G19T212	G23T212	
23TG122a	G19T213	G24T230	
23TG131a	G19T214	G24T232	
23TG142a	G19T215	G24T236	
23TG152a	G20T230	G24T238	
23TG153a	G20T232	G24T300	
23TG156a	G20T236	G24T301	
23TG164a	G20T238	G24T302	
23TG170a	G20T300	G24T306	
23TG171a	G20T301	G24T307	
23TG173a	G20T302	G24T308	
23TG175a	G20T306	G24T324	
23TG176a	G20T307		
23FG632	G20T308		

GEC				
2000	2015	2022	2043	2064
2001	2017	2023	2044	2065
2010	2018	2032	2047	2066
2012	2019	2033	2048	2082
2013	2020	2038	2063	2083
2014	2021	2039		

PYE			
11q Series			
12u			
13u	State Pt. No.		
14u	required		
15u	AL21003 or		
20u	772494		
V700 or A or D			
V710 or A or D	State Pt. No.		
V720	required—		
V830A or D or	772444 or		
LBA	771935		

FERGUSON, ULTRA, MARCONI, H.M.V. (BRC, Jellypots). ALL MODELS IN STOCK.

ALBA, COSSOR, EKCO, FERRANTI, K.B., PYE. ALL MODELS IN STOCK.

E.H.T. RECTIFIER TRAYS (MONOCHROME)

THORN B.R.C. MONOCHROME	ORDER Ref.	
980, 981, 982	RT1	£3.30
911, 950/1, 960	RT2	£3.60
950/2, 1400-5 stick	RT3	£3.90
1400 Portable-3 stick	RT3A	£3.60
1500 20" 3 stick	RT4	£3.60
1500 24" 5 stick	RT5	£3.90
1580 Portable-2 stick	RT16	£3.50
1590, 1591	RT17	£1.30

E.H.T. RECTIFIER TRAYS (COLOUR)

MAKE	CHASSIS COLOUR	
DECCA	CTV19, CTV25	£8.00
DECCA	CS1910, CS2213	£8.00
DECCA	CS1730	£5.80
GEC	Dual & Single std. Valve Type	£6.70
ITT-KB	CVC-1, 2, 3	£7.20
PHILIPS	G8 510-550 Series	£7.20
PYE	691, 692, 693, 697	£6.70
PYE	713 CT200	£6.40
BUSH MURPHY	Single std plug-in	£8.00
BUSH MURPHY	Dual standard	£9.80
THORN BRC	2000	£8.00
THORN BRC	3000	£7.10
THORN BRC	8000	£4.10
THORN BRC	8500	£7.00
GEC	Solid State 90°	£8.50
PYE	CT262 & 266 731 Chassis	£7.40

COLOUR TV Line out-put transformers

THORN (BRC)			
2000 Chassis			
Scan O/P Tx.			
EHT O/P Tx.			
3000 Chassis			
Scan O/P Tx.			
EHT O/P Tx.			
8000 Chassis			
8500 Chassis			
All £6.80 ea.			
GEC			
Dual Standard			
Single Standard			
£8.86 ea.			
ITT-KB			
CVC1 Chassis			
CVC2 ..			
CVC5 Chassis			
£7.10 ea.			
PHILIPS			
G6 Chassis D/S			
G6 .. S/S			
£9.40 ea.			
G8 Chassis			
£8.32 ea.			
BUSH			
CTV25 Mk. 1 & 2			
£12.00 ea.			
CTV25 Mk.3			
CTV162			
£7.90 ea.			
CTV167 Mk.1 & 2			
£12.00 ea.			
CTV167 Mk.3			
CTV174D			
CTV182S			
CTV184S			
CTV187CS			
CTV194S			
CTV197C			
CTV199S			
£7.90 ea.			
DECCA			
CTV19 Valve Rec.			
CTV25 ..			
Primary Coil			
£3.70 ea.			
CTV19 D/S Tripler			
CTV25			
CTV25 S/S Tripler			
CS1730			
CS1910			
CS2030			
CS2213			
CS2220			
CS2225			
£7.24 ea.			
EKCO			
CT102			
CT104			
£13.00 ea.			
CT103			
CT105			
CT106			
CT107			
CT108			
CT109			
CT111			
CT120			
CT121	&/T		
CT122			
£9.90 ea.			
PYE			
CT70			
CT71			
£13.00 ea.			
CT72			
CT73			
CT78			
CT79			
CT152			
CT153			
CT154			
£9.90 ea.			
MURPHY			
CV1912	CV2510 Mk.3		
CV1916S	CV2511 Mk.3		
CV2210	CV2516S		
CV2212	CV2610		
CV2113	CV2611		
CV2214	CV2614		
	£7.90 ea.		
CV2510 Mk. 1 & 2			
CV2511 Mk. 1 & 2			
£12.00 ea			

Most items listed stocked. Most newer and older models in stock. S.A.E. for quotation For by-return service contact your nearest depot. Callers welcome.

Tidman Mail Order Ltd., Dept. NA.
236 Sandycroft Road,
Richmond, Surrey.
London: 01-948 3702

Hamond Components (Midland) Ltd., Dept. NA.
89 Meriden Street,
Birmingham 5.
Birmingham: 021-643 2148

MON - FRI 9 am to 12.30 pm 1.30 pm to 4.30 pm
SAT 10 am to 12 noon

NO HIDDEN EXTRAS - PRICES INCLUDE V.A.T. and CARRIAGE