

TELEVISION

20p (4/0)

SERVICING · CONSTRUCTION · COLOUR · DEVELOPMENTS

MAY
1971

DIRECT-READING ANALOGUE/DIGITAL FREQUENCY METER

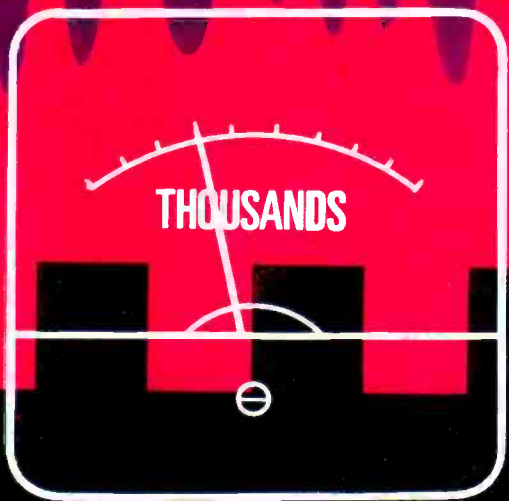
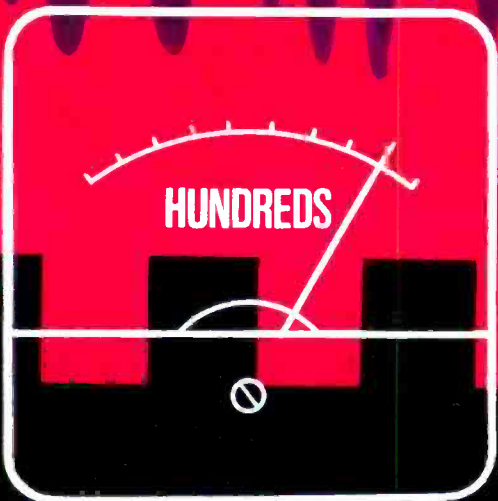
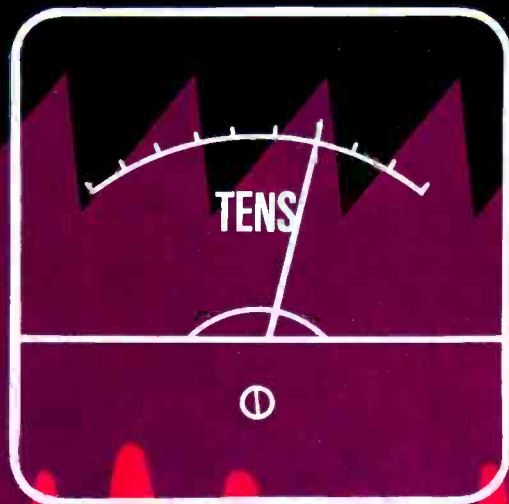
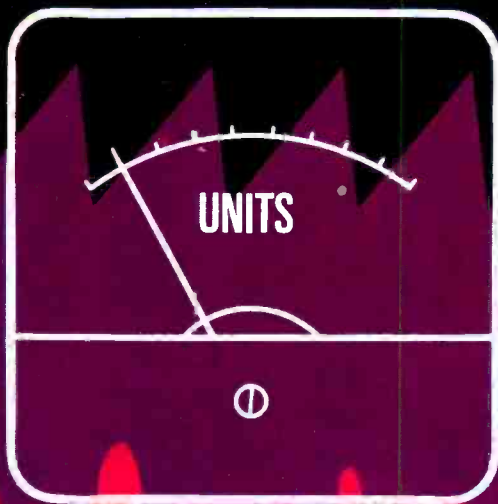

ALSO : SHADOWMASK TUBE FAULTS
HI FI TV SOUND UNIT
SERVICING THE PHILIPS STYLE 70 SERIES

TELEVISION SERVICING HANDBOOK

3rd Edition

**Gordon J. King, AssocIERE, MIPRE, MRTS, MAES,
GradITAI, Dip. Television**

A thoroughly practical handbook intended mainly for the professional service engineer, although it should also prove of the greatest interest to radio amateurs, students and apprentices. It deals in detail with fault-tracing, alignment adjustment and repair on modern receivers of all types.

0 408 00033 3 358 pages illustrated 1971 £3·80

COLOUR TELEVISION SERVICING

**Gordon J. King, AssocIERE, MIPRE, MRTS MAES,
GradITAI, Dip. Television**

This comprehensive book deals straightforwardly with the servicing of PAL receivers, using a minimum of mathematics. It is divided into three sections: the first surveys the colour TV system as a whole, the second studies the elements involved (e.g. picture tubes, conveyance systems, chroma channels) and the third is devoted exclusively to servicing.

0 408 00044 9 328 pages illustrated 1971 £4·40

Available from leading booksellers or



The Butterworth Group 88 Kingsway London WC2B 6AB

Showrooms and Trade Counter, 4-5 Bell Yard London WC2

REBUILT TUBES!

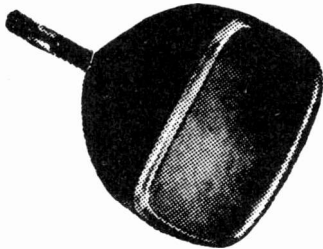

**YOU'RE
SAFE
WHEN YOU
BUY FROM
RE-VIEW!**

HERE IS WHAT YOU PAY:

12in.	£4·75	19in.	£5·87
14in.	£5·00	21in.	£7·25
15in.	£5·25	23in.	£8·50
17in.	£5·25	19in. Twin Panel	£7·50

23in. Twin Panel £10

Cash or cheque with order, or cash on delivery

Discount for Trade

- ★ Each tube is rebuilt with a completely new gun assembly and the correct voltage heater.
- ★ Each tube comes to you with a guarantee card covering it for two years against all but breakage.
- ★ Each tube is delivered free anywhere in the U.K. and insured on the journey.
- ★ Each tube is rebuilt with experience and know-how. We were amongst the very first to pioneer the technique of rebuilding television tubes.

RE-VIEW ELECTRONIC TUBES

237 London Road, West Croydon, Surrey
Tel. 01-689/7735

2 NEW "TELEBOOSTERS"

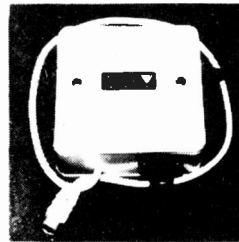

**THE M4
DUAL BAND
V.H.F. UNIT**

KING . . .

the name you
can depend on.

- * Boosts all Band III and any specified Band I Channel simultaneously.
- * Still higher gain . . . nominally 17-18 d.B. both Bands.
- * Very low noise third generation passivated transistor.
- * Fitted fly lead . . . installed in seconds.
- * Quality Case 3¼" × 3¼" × 1½" Cork base.
Specify Band I channel when ordering.

THE NEW UM4 UHF "COLOURBOOSTER"
Channels: Group "A" Red Spot. "B" Yellow Spot,
"C" Green Spot. Prices: Both types—£3·75 Battery
Model OR £5·87½ Self Contained Mains Model.
P/P 12½p

TRANSISTOR DEVICES LIMITED
Bridge House, NEWTON ABBOT, Devon.

Literature on request.

WILLOW VALE ELECTRONICS LIMITED

The Service Department Wholesalers
Compare our prices

e.g. NEW 19" C.R.T's . . . OUR PRICE £7.95 Plus 65p carriage

<p>Please note: Components are sold in packs, quantities per pack are shown under each heading. Prices are per piece of each value.</p>		<p>SUB-MINIATURE ELECTROLYTICS (5's)</p> <table border="1"> <tr><td>1mf</td><td>18v.</td><td>£0-09</td></tr> <tr><td>2mf</td><td>18v.</td><td>£0-09</td></tr> <tr><td>4mf</td><td>18v.</td><td>£0-09</td></tr> <tr><td>5mf</td><td>18v.</td><td>£0-09</td></tr> <tr><td>8mf</td><td>18v.</td><td>£0-09</td></tr> <tr><td>10mf</td><td>18v.</td><td>£0-09</td></tr> <tr><td>16mf</td><td>18v.</td><td>£0-09</td></tr> <tr><td>25mf</td><td>18v.</td><td>£0-09</td></tr> <tr><td>32mf</td><td>18v.</td><td>£0-09</td></tr> <tr><td>50mf</td><td>18v.</td><td>£0-09</td></tr> <tr><td>100mf</td><td>18v.</td><td>£0-09</td></tr> <tr><td>200mf</td><td>18v.</td><td>£0-09</td></tr> </table>		1mf	18v.	£0-09	2mf	18v.	£0-09	4mf	18v.	£0-09	5mf	18v.	£0-09	8mf	18v.	£0-09	10mf	18v.	£0-09	16mf	18v.	£0-09	25mf	18v.	£0-09	32mf	18v.	£0-09	50mf	18v.	£0-09	100mf	18v.	£0-09	200mf	18v.	£0-09	<p>RADIO/TV GLASS FUSES</p> <p>1 amp, 1.5 amp, 2 amp, 3 amp. Per dozen £0-15</p> <hr/> <p>MAINS FUSES</p> <p>2 amp, 3 amp, 5 amp, 13 amp. Per dozen £0-25</p> <hr/> <p>TERMINAL STRIPS</p> <p>2 amp £0-12 5 amp £0-14 15 amp £0-29</p>																																																																							
1mf	18v.	£0-09																																																																																																													
2mf	18v.	£0-09																																																																																																													
4mf	18v.	£0-09																																																																																																													
5mf	18v.	£0-09																																																																																																													
8mf	18v.	£0-09																																																																																																													
10mf	18v.	£0-09																																																																																																													
16mf	18v.	£0-09																																																																																																													
25mf	18v.	£0-09																																																																																																													
32mf	18v.	£0-09																																																																																																													
50mf	18v.	£0-09																																																																																																													
100mf	18v.	£0-09																																																																																																													
200mf	18v.	£0-09																																																																																																													
<p>TUBULAR CAPACITORS (5's)</p> <table border="1"> <tr><td>.001</td><td>400v.</td><td>£0-04</td></tr> <tr><td>.0022</td><td>600v.</td><td>£0-04</td></tr> <tr><td>.0033</td><td>600/1500v.</td><td>£0-04</td></tr> <tr><td>.0047</td><td>600/1500v.</td><td>£0-04</td></tr> <tr><td>.01</td><td>400v.</td><td>£0-04</td></tr> <tr><td>.022</td><td>600v.</td><td>£0-05</td></tr> <tr><td>.033</td><td>600v.</td><td>£0-05</td></tr> <tr><td>.047</td><td>600v.</td><td>£0-05</td></tr> <tr><td>.1</td><td>600v.</td><td>£0-05</td></tr> <tr><td>.22</td><td>600v.</td><td>£0-10</td></tr> <tr><td>.47</td><td>600v.</td><td>£0-14</td></tr> <tr><td>.01</td><td>1000v.</td><td>£0-06</td></tr> <tr><td>.022</td><td>1000v.</td><td>£0-06</td></tr> <tr><td>.047</td><td>1000v.</td><td>£0-09</td></tr> <tr><td>.1</td><td>1000v.</td><td>£0-09</td></tr> <tr><td>.22</td><td>1000v.</td><td>£0-14</td></tr> <tr><td>.47</td><td>1000v.</td><td>£0-19</td></tr> <tr><td>.001</td><td>1500v.</td><td>£0-08</td></tr> </table>		.001	400v.	£0-04	.0022	600v.	£0-04	.0033	600/1500v.	£0-04	.0047	600/1500v.	£0-04	.01	400v.	£0-04	.022	600v.	£0-05	.033	600v.	£0-05	.047	600v.	£0-05	.1	600v.	£0-05	.22	600v.	£0-10	.47	600v.	£0-14	.01	1000v.	£0-06	.022	1000v.	£0-06	.047	1000v.	£0-09	.1	1000v.	£0-09	.22	1000v.	£0-14	.47	1000v.	£0-19	.001	1500v.	£0-08	<p>BIAS ELECTROLYTICS (5's)</p> <table border="1"> <tr><td>25mf</td><td>25v.</td><td>£0-07</td></tr> <tr><td>50mf</td><td>25v.</td><td>£0-08</td></tr> <tr><td>100mf</td><td>25v.</td><td>£0-10</td></tr> <tr><td>250mf</td><td>25v.</td><td>£0-15</td></tr> <tr><td>500mf</td><td>25v.</td><td>£0-19</td></tr> <tr><td>1000mf</td><td>12v.</td><td>£0-30</td></tr> <tr><td>1000mf</td><td>30v.</td><td>£0-30</td></tr> <tr><td>2000mf</td><td>25v.</td><td>£0-35</td></tr> <tr><td>2500mf</td><td>30v.</td><td>£0-45</td></tr> <tr><td>3000mf</td><td>30v.</td><td>£0-47</td></tr> <tr><td>5000mf</td><td>30v.</td><td>£0-55</td></tr> <tr><td>25mf</td><td>50v.</td><td>£0-08</td></tr> <tr><td>50mf</td><td>50v.</td><td>£0-10</td></tr> <tr><td>100mf</td><td>50v.</td><td>£0-13</td></tr> <tr><td>250mf</td><td>50v.</td><td>£0-18</td></tr> <tr><td>500mf</td><td>50v.</td><td>£0-24</td></tr> <tr><td>2000mf</td><td>50v.</td><td>£0-47</td></tr> <tr><td>2500mf</td><td>50v.</td><td>£0-55</td></tr> </table>		25mf	25v.	£0-07	50mf	25v.	£0-08	100mf	25v.	£0-10	250mf	25v.	£0-15	500mf	25v.	£0-19	1000mf	12v.	£0-30	1000mf	30v.	£0-30	2000mf	25v.	£0-35	2500mf	30v.	£0-45	3000mf	30v.	£0-47	5000mf	30v.	£0-55	25mf	50v.	£0-08	50mf	50v.	£0-10	100mf	50v.	£0-13	250mf	50v.	£0-18	500mf	50v.	£0-24	2000mf	50v.	£0-47	2500mf	50v.	£0-55
.001	400v.	£0-04																																																																																																													
.0022	600v.	£0-04																																																																																																													
.0033	600/1500v.	£0-04																																																																																																													
.0047	600/1500v.	£0-04																																																																																																													
.01	400v.	£0-04																																																																																																													
.022	600v.	£0-05																																																																																																													
.033	600v.	£0-05																																																																																																													
.047	600v.	£0-05																																																																																																													
.1	600v.	£0-05																																																																																																													
.22	600v.	£0-10																																																																																																													
.47	600v.	£0-14																																																																																																													
.01	1000v.	£0-06																																																																																																													
.022	1000v.	£0-06																																																																																																													
.047	1000v.	£0-09																																																																																																													
.1	1000v.	£0-09																																																																																																													
.22	1000v.	£0-14																																																																																																													
.47	1000v.	£0-19																																																																																																													
.001	1500v.	£0-08																																																																																																													
25mf	25v.	£0-07																																																																																																													
50mf	25v.	£0-08																																																																																																													
100mf	25v.	£0-10																																																																																																													
250mf	25v.	£0-15																																																																																																													
500mf	25v.	£0-19																																																																																																													
1000mf	12v.	£0-30																																																																																																													
1000mf	30v.	£0-30																																																																																																													
2000mf	25v.	£0-35																																																																																																													
2500mf	30v.	£0-45																																																																																																													
3000mf	30v.	£0-47																																																																																																													
5000mf	30v.	£0-55																																																																																																													
25mf	50v.	£0-08																																																																																																													
50mf	50v.	£0-10																																																																																																													
100mf	50v.	£0-13																																																																																																													
250mf	50v.	£0-18																																																																																																													
500mf	50v.	£0-24																																																																																																													
2000mf	50v.	£0-47																																																																																																													
2500mf	50v.	£0-55																																																																																																													
<p>WIRE-WOUND RESISTORS (5's)</p> <p>10 watt rating, suitable for mains dropper sections.</p> <table border="1"> <tr><td>1</td><td>Ohm</td><td>£0-09</td></tr> <tr><td>10</td><td>Ohms</td><td>£0-09</td></tr> <tr><td>13</td><td>"</td><td>£0-09</td></tr> <tr><td>25</td><td>"</td><td>£0-09</td></tr> <tr><td>33</td><td>"</td><td>£0-09</td></tr> <tr><td>50</td><td>"</td><td>£0-09</td></tr> <tr><td>87</td><td>"</td><td>£0-09</td></tr> <tr><td>100</td><td>"</td><td>£0-09</td></tr> <tr><td>150</td><td>"</td><td>£0-09</td></tr> <tr><td>220</td><td>"</td><td>£0-09</td></tr> <tr><td>330</td><td>"</td><td>£0-09</td></tr> <tr><td>1K</td><td>"</td><td>£0-09</td></tr> <tr><td>2.2K</td><td>"</td><td>£0-09</td></tr> <tr><td>3.3K</td><td>"</td><td>£0-09</td></tr> <tr><td>4.7K</td><td>"</td><td>£0-09</td></tr> </table>		1	Ohm	£0-09	10	Ohms	£0-09	13	"	£0-09	25	"	£0-09	33	"	£0-09	50	"	£0-09	87	"	£0-09	100	"	£0-09	150	"	£0-09	220	"	£0-09	330	"	£0-09	1K	"	£0-09	2.2K	"	£0-09	3.3K	"	£0-09	4.7K	"	£0-09	<p>SMOOTHING ELECTROLYTICS</p> <p>Wire ended, 450v. working.</p> <table border="1"> <tr><td>1mf</td><td>£0-07</td></tr> <tr><td>2mf</td><td>£0-08</td></tr> <tr><td>4mf</td><td>£0-11</td></tr> <tr><td>8mf</td><td>£0-13</td></tr> <tr><td>16mf</td><td>£0-16</td></tr> <tr><td>32mf</td><td>£0-23</td></tr> <tr><td>50mf</td><td>£0-25</td></tr> <tr><td>8/8mf</td><td>£0-19</td></tr> <tr><td>8/16mf</td><td>£0-25</td></tr> <tr><td>16/16mf</td><td>£0-26</td></tr> <tr><td>16/32mf</td><td>£0-27</td></tr> <tr><td>32/32mf</td><td>£0-27</td></tr> <tr><td>50/50mf</td><td>£0-42</td></tr> <tr><td>50/50/50mf</td><td>£0-52</td></tr> </table>		1mf	£0-07	2mf	£0-08	4mf	£0-11	8mf	£0-13	16mf	£0-16	32mf	£0-23	50mf	£0-25	8/8mf	£0-19	8/16mf	£0-25	16/16mf	£0-26	16/32mf	£0-27	32/32mf	£0-27	50/50mf	£0-42	50/50/50mf	£0-52																																			
1	Ohm	£0-09																																																																																																													
10	Ohms	£0-09																																																																																																													
13	"	£0-09																																																																																																													
25	"	£0-09																																																																																																													
33	"	£0-09																																																																																																													
50	"	£0-09																																																																																																													
87	"	£0-09																																																																																																													
100	"	£0-09																																																																																																													
150	"	£0-09																																																																																																													
220	"	£0-09																																																																																																													
330	"	£0-09																																																																																																													
1K	"	£0-09																																																																																																													
2.2K	"	£0-09																																																																																																													
3.3K	"	£0-09																																																																																																													
4.7K	"	£0-09																																																																																																													
1mf	£0-07																																																																																																														
2mf	£0-08																																																																																																														
4mf	£0-11																																																																																																														
8mf	£0-13																																																																																																														
16mf	£0-16																																																																																																														
32mf	£0-23																																																																																																														
50mf	£0-25																																																																																																														
8/8mf	£0-19																																																																																																														
8/16mf	£0-25																																																																																																														
16/16mf	£0-26																																																																																																														
16/32mf	£0-27																																																																																																														
32/32mf	£0-27																																																																																																														
50/50mf	£0-42																																																																																																														
50/50/50mf	£0-52																																																																																																														
<p>PULSE CERAMICS (5's) 12KV</p> <table border="1"> <tr><td>100pf</td><td>22pf</td><td>£0-06</td></tr> <tr><td>120pf</td><td>47pf</td><td>£0-06</td></tr> <tr><td>180pf</td><td>68pf</td><td>£0-06</td></tr> <tr><td>250pf</td><td>100pf</td><td>£0-06</td></tr> </table> <p>Tubular type for use in Scan correction circuits and Line Outputs.</p>		100pf	22pf	£0-06	120pf	47pf	£0-06	180pf	68pf	£0-06	250pf	100pf	£0-06	<p>CANNED ELECTROLYTICS</p> <table border="1"> <tr><td>100/200mf</td><td>£0-63</td></tr> <tr><td>100/400mf</td><td>£0-83</td></tr> <tr><td>200/200mf</td><td>£0-85</td></tr> <tr><td>200/200/100mf</td><td>£0-95</td></tr> <tr><td>200/400/32mf</td><td>£0-95</td></tr> <tr><td>100/300/100/16</td><td>£0-95</td></tr> <tr><td>100/400/32mf</td><td>£0-95</td></tr> <tr><td>100/400/64/16</td><td>£1-07</td></tr> </table>		100/200mf	£0-63	100/400mf	£0-83	200/200mf	£0-85	200/200/100mf	£0-95	200/400/32mf	£0-95	100/300/100/16	£0-95	100/400/32mf	£0-95	100/400/64/16	£1-07																																																																																
100pf	22pf	£0-06																																																																																																													
120pf	47pf	£0-06																																																																																																													
180pf	68pf	£0-06																																																																																																													
250pf	100pf	£0-06																																																																																																													
100/200mf	£0-63																																																																																																														
100/400mf	£0-83																																																																																																														
200/200mf	£0-85																																																																																																														
200/200/100mf	£0-95																																																																																																														
200/400/32mf	£0-95																																																																																																														
100/300/100/16	£0-95																																																																																																														
100/400/32mf	£0-95																																																																																																														
100/400/64/16	£1-07																																																																																																														
<p>CERAMICS (6's)</p> <table border="1"> <tr><td>500pf</td><td>22pf</td><td>£0-03</td></tr> <tr><td>680pf</td><td>47pf</td><td>£0-03</td></tr> <tr><td>820pf</td><td>68pf</td><td>£0-03</td></tr> <tr><td>1000pf</td><td>100pf</td><td>£0-03</td></tr> <tr><td>1500pf</td><td>120pf</td><td>£0-03</td></tr> <tr><td>3000pf</td><td>180pf</td><td>£0-03</td></tr> <tr><td>5000pf</td><td></td><td>£0-03</td></tr> </table>		500pf	22pf	£0-03	680pf	47pf	£0-03	820pf	68pf	£0-03	1000pf	100pf	£0-03	1500pf	120pf	£0-03	3000pf	180pf	£0-03	5000pf		£0-03	<p>SKELETON PRE-SETS (5's)</p> <table border="1"> <tr><td>25K</td><td>Vertical</td><td>£0-07</td></tr> <tr><td>50K</td><td>"</td><td>£0-07</td></tr> <tr><td>100K</td><td>"</td><td>£0-07</td></tr> <tr><td>250K</td><td>"</td><td>£0-07</td></tr> <tr><td>500K</td><td>"</td><td>£0-07</td></tr> <tr><td>1 meg</td><td>"</td><td>£0-07</td></tr> <tr><td>2 meg</td><td>"</td><td>£0-07</td></tr> <tr><td>500K</td><td>Horizontal</td><td>£0-07</td></tr> <tr><td>680V</td><td>"</td><td>£0-07</td></tr> <tr><td>1 meg</td><td>"</td><td>£0-07</td></tr> </table>		25K	Vertical	£0-07	50K	"	£0-07	100K	"	£0-07	250K	"	£0-07	500K	"	£0-07	1 meg	"	£0-07	2 meg	"	£0-07	500K	Horizontal	£0-07	680V	"	£0-07	1 meg	"	£0-07																																																									
500pf	22pf	£0-03																																																																																																													
680pf	47pf	£0-03																																																																																																													
820pf	68pf	£0-03																																																																																																													
1000pf	100pf	£0-03																																																																																																													
1500pf	120pf	£0-03																																																																																																													
3000pf	180pf	£0-03																																																																																																													
5000pf		£0-03																																																																																																													
25K	Vertical	£0-07																																																																																																													
50K	"	£0-07																																																																																																													
100K	"	£0-07																																																																																																													
250K	"	£0-07																																																																																																													
500K	"	£0-07																																																																																																													
1 meg	"	£0-07																																																																																																													
2 meg	"	£0-07																																																																																																													
500K	Horizontal	£0-07																																																																																																													
680V	"	£0-07																																																																																																													
1 meg	"	£0-07																																																																																																													
<p>RECORD PLAYER CARTRIDGES</p> <p>ACOS: GP67/2g. High gain general purpose Mono GP91/3C. Stereo-compatible replacement GP91/3SC. High gain version of above GP94/1SS. Stereo cartridge</p> <p>GENERAL PURPOSE REPLACEMENT FOR TC8's etc. High gain, plenty of output (Jap.) Stereo version</p>		<p>DOUBLE DIODE RECTIFIERS (5's)</p> <p>Bush/Murphy/BRC, etc. Line/frame timebases etc.</p> <table border="1"> <tr><td>3 leg</td><td>£0-31</td></tr> <tr><td>4 leg</td><td>£0-31</td></tr> <tr><td>5 leg</td><td>£0-31</td></tr> </table>		3 leg	£0-31	4 leg	£0-31	5 leg	£0-31																																																																																																						
3 leg	£0-31																																																																																																														
4 leg	£0-31																																																																																																														
5 leg	£0-31																																																																																																														
<p>RECTIFIERS Silicon Mains (5's)</p> <p>Westinghouse S10AR2 £0-33 BY127 Mullard £0-26 BY327 £0-25</p>		<p>CONTACT COOLED FULL WAVE</p> <table border="1"> <tr><td>75ma</td><td>£0-60</td></tr> <tr><td>100ma</td><td>£0-70</td></tr> <tr><td>150ma</td><td>£0-86</td></tr> </table>		75ma	£0-60	100ma	£0-70	150ma	£0-86																																																																																																						
75ma	£0-60																																																																																																														
100ma	£0-70																																																																																																														
150ma	£0-86																																																																																																														
<p>CO-AXIAL PLUGS</p> <p>Bakelite top £0-04 Egen metal £0-08 Single point (car radio) £0-10</p>		<p>SLIDER PRE-SETS (3's)</p> <table border="1"> <tr><td>100K</td><td>£0-08</td></tr> <tr><td>1 Meg</td><td>£0-08</td></tr> <tr><td>2.2 Meg</td><td>£0-08</td></tr> </table>		100K	£0-08	1 Meg	£0-08	2.2 Meg	£0-08																																																																																																						
100K	£0-08																																																																																																														
1 Meg	£0-08																																																																																																														
2.2 Meg	£0-08																																																																																																														
<p>JACK PLUGS</p> <p>Chrome standard £0-20 Standard £0-15 3.5mm. metal £0-15</p>		<p>DIN PLUGS (2's)</p> <table border="1"> <tr><td>3-pin</td><td>£0-10</td></tr> <tr><td>5-pin</td><td>£0-11</td></tr> <tr><td>Sockets</td><td>£0-06</td></tr> </table>		3-pin	£0-10	5-pin	£0-11	Sockets	£0-06																																																																																																						
3-pin	£0-10																																																																																																														
5-pin	£0-11																																																																																																														
Sockets	£0-06																																																																																																														
<p>VOLUME CONTROLS</p> <p>Standard spindle with flat. £0-25 Double pole switch £0-19 Without switch (One per pack) 5K, 10K, 25K, 50K, 100K, 250K, 500K, 1 meg, 2 meg.</p>		<p>REPLACEMENT STYLI</p> <table border="1"> <tr><td>TC8</td><td>£0-23</td></tr> <tr><td>GC8</td><td>£0-23</td></tr> </table>		TC8	£0-23	GC8	£0-23																																																																																																								
TC8	£0-23																																																																																																														
GC8	£0-23																																																																																																														

MOBILE STORES VANS IN LONDON, WEST COUNTRY AND SCOTLAND

<p>RECORD PLAYER CARTRIDGES</p> <p>ACOS: GP67/2g. High gain general purpose Mono GP91/3C. Stereo-compatible replacement GP91/3SC. High gain version of above GP94/1SS. Stereo cartridge</p> <p>GENERAL PURPOSE REPLACEMENT FOR TC8's etc. High gain, plenty of output (Jap.) Stereo version</p>	<p>SERVISOL AND ELECTROLUBE PRODUCTS (Nett trade)</p> <table border="1"> <tr><td>£0-83</td><td>Servisol aerosol can</td><td>£0-63 nett</td></tr> <tr><td>£1-10</td><td>Electrolube 2AX aerosol</td><td>£0-70 nett</td></tr> <tr><td>£1-10</td><td>Servisol Freezit</td><td>£0-47 nett</td></tr> <tr><td>£1-89</td><td>Electrolube No. 1 Snorkel</td><td>£0-90 nett</td></tr> <tr><td>£0-99</td><td>Electrolube 2GX Grease</td><td>£0-42 nett</td></tr> <tr><td>£1-89</td><td>Servisol Aero-Clene for tape heads</td><td>£0-53 nett</td></tr> <tr><td></td><td>Servisol Aero-Duster</td><td>£0-53 nett</td></tr> </table>	£0-83	Servisol aerosol can	£0-63 nett	£1-10	Electrolube 2AX aerosol	£0-70 nett	£1-10	Servisol Freezit	£0-47 nett	£1-89	Electrolube No. 1 Snorkel	£0-90 nett	£0-99	Electrolube 2GX Grease	£0-42 nett	£1-89	Servisol Aero-Clene for tape heads	£0-53 nett		Servisol Aero-Duster	£0-53 nett	<p>REPLACEMENT STYLI</p> <table border="1"> <tr><td>TC8</td><td>£0-23</td></tr> <tr><td>GC8</td><td>£0-23</td></tr> </table>	TC8	£0-23	GC8	£0-23
£0-83	Servisol aerosol can	£0-63 nett																									
£1-10	Electrolube 2AX aerosol	£0-70 nett																									
£1-10	Servisol Freezit	£0-47 nett																									
£1-89	Electrolube No. 1 Snorkel	£0-90 nett																									
£0-99	Electrolube 2GX Grease	£0-42 nett																									
£1-89	Servisol Aero-Clene for tape heads	£0-53 nett																									
	Servisol Aero-Duster	£0-53 nett																									
TC8	£0-23																										
GC8	£0-23																										

REBUILT AND NEW TUBES—TWO YEARS' GUARANTEE

REBUILT	BRAND NEW	A FEW SAMPLE TYPES, REMEMBER WE STOCK EVERY TUBE
17" @ £5.95	£6.50	CME1702, AW43-80, CRM173, MW43-80, MW43-69*, CRM172*, AW43-88, AW43-89, CME1705, CME1703, C17AF, C17SM, etc.
19" @ £5.95	£7.95	CME1903, CME1902, CME1901, AW47-90, AW47-91, A47-14W, C19AH, C19AF, C19A.
21" @ £7.95	£9.90	CME2101, AW53-88, AW53-89, CRM211*, CRM212*, MW53-20*, MW53-80*.
23" @ £7.95	£10.80	CME2303, CME2301, AW59-90, AW59-91.

COLOUR TUBES
IN STOCK.
PRICES ON
APPLICATION

ALL PRICES ARE NETT

TWIN
PANELS

19"

CME1906
A47-13W }

ON APPLICATION

23"

CME2306
A59/13W }

ON APPLICATION

*NEW ONLY. NO REBUILDS

EVERY TUBE IN STOCK INCLUDING 12", 16" PORTABLES, PANORAMA & RINGUARDS. TERMS: CASH WITH ORDER. CARRIAGE ANYWHERE IN GT. BRITAIN 65p per Tube

HOT-LINE ORDERS
TRADE ONLY
Tel: 01-567 5400/2971

RADIO AND TELEVISION VALVES SMALL SELECTION

British made valves normally supplied. EVERY TYPE IN STOCK

DY86/7	EY86/7	PCL86
DY802	EZ80	PD500
EABC80	EZ81	PFL200
EB91	EZ90	PL36
EBC90	GZ34	PL81
EBF80	CY501	PL81A
EBF89	PC86	PL82
ECC81	PC88	PL83
ECC82	PC97	PL84
ECC83	PC900	PL302
ECC804	PCC84	PL504
ECH81	PCC88	PL508
ECH84	PCC89	PL509
ECL80	PCC189	PY33
ECL82	PCC806	PY81
ECL83	PCF80	PY800
ECL84	PCF86	PY801
ECL86	PCF87	PY82
EF80	PCF801	PY83
EF85	PCF802	PY500
EF86	PCF805	UABC80
EF89	PCF806	UCH81
EF183	PCF808	UCL82
EF184	PCL82	UCL83
EH90	PCL83	UL41
EL34	PCL84	UL84
EY51	PCL85	UY85

VALVE DISCOUNTS
42% ORDERS UP TO £50
50% ORDERS OVER £50

ALL MAZDA/BRIMAR TYPES IN STOCK.

TRADE & SERVICE ENGINEERS ONLY SUPPLIED

Cash with order. 10% MAY BE DEDUCTED FROM THE ADVERTISED PRICES EXCEPT FOR NETT ITEMS, C.O.D., OR TUBES

All orders must exceed £5.00 in value otherwise postage and packing will be charged at 25p per invoice. Components must be ordered in multiples as packed.

COMPREHENSIVE CATALOGUE listing valves, tubes, L.O.P.T.'s components, transistors, including HUGE VALVE EQUIVALENTS LIST. 15p in loose stamps, please.

L.O.P.T.'s

LINE OUTPUT
TRANSFORMERS

ALL MAKES SUPPLIED

L.O.P.T.'s ONLY AVAILABLE
FROM LONDON DEPOT

EXCHANGE UNITS AND NEW REPLACEMENTS

EVERY MAKE SUPPLIED
(EXCEPT MURPHY OIL-FILLED)

REWIND SERVICE FOR OBSOLETE MODELS

FRAME OUTPUT, SOUND OUTPUT AND
MAINS TRANSFORMERS REWOUND

REMEMBER . . . We are the Service department Wholesalers and supply only the Service Engineers' requirements and can therefore carry large stocks, and also we know and understand your problems regarding getting the right spares QUICKLY and the RIGHT PRICE.
HOT-LINE ORDERS: LONDON 01-567 5400-2971. 01-579-3582. SOMERSET 045-84-2597

4 & 5 THE BROADWAY, HANWELL, LONDON, W.7
Telephones: 01-567 5400 01-567 2971 01-579 3582
42 WEST END, STREET, SOMERSET 045-84 2597

NEW LINE OUTPUT TRANSFORMERS

ALBA 655, 656, 717, 721 £3-75. 890-895, 1090, 1135, 1195, 1235, 1395, 1435 £5-90.
BAIRD. Prices on request. From model 600 quote part no. normally found on TX base plate.
BUSH TV53 to TUG69 £2-00. TV91 to TV139 £4-75. (From Model TV123 an alternative Square Tag Panel was fitted on Main Bobbin, please state if required.) TV141 to TV176 Rewind £4-50.
COSSOR 904 to 957 Rewind £4-50. CT1700U to CT2378A £5-90.
DECCA DM1, DM3C, (90°) £3-90. DM4C (70°) £3-90. DR1, DR2, DR121 £4-50.
DEFIANT 7P20 to 7609. Prices on request.
DYNATRON TV30, TV35 £2-77½. TV36, TV37, TV38, TV39, TV40, TV41, etc. £4-00.
EKCO T231, T284, TC267, T283, T293, T311, T326, T327, T330 £2-77½. TMB272 £3-42½. T344, T344F, T345, TP347, T348, T348F, TC347, TC349, TC356, T368, T370, TC369, T371, T372, TP373, TC374, T377A, T393, T394, 433, 434, 435, 436, 437 all at £4-00. 503, 504, 505, 506 £4-75.
FERGUSON 306T, 308T £2-77½ each. 406T, 408T, 416, 436, 438, 506, 508, 516, 518, 536, 546, 604, 606, 608, 616, 619, 636, 646, 648, 725, 726, 727, 3600, 3601, 3602, 3604, 3611, 3612, 3614, 3617, 3618, 3619, 3620, 3621, 3622, 3623, 3624, 3625, 3626, 3627 3629 £4-00. Jelly Pots, please state colour: red, black or white.
FERRANTI T1001, T1002, T1002/1, T1004, T1005 £2-75. T1023, T1024, T1027, T1027F, TP1026, T1071, T1072, T1121, TC1122, TC1124, T1125, TC1126 £4-00. 1154, 1155 £4-75.
G.E.C. BT302, BT342 £3-12½. BT454DST-456DST, 2010, 2013, 2014, 2012, 2000DS, 2001DS, 2002DS £4-25.
H.M.V. 1865, 1869 £2-77½. 1870, 1872, 1874, 1876, 1890, 1892, 1894, 1896 £4-00.
KB OV30, NF70, NV40, PV40, QV10, QV30, RV10, RV20, RV30, PVP20 £4-50. Featherlight £4-50. Chassis No. VC1-VC2-VC3-VC4 £4-50.
MASTERADIO 4013 DST, D500 DST, D507 DST £4-25.
MARCONI VT153, VT155, VT156 £2-77½. VT157, VT159, VT161, VT163, VT165, VT170, 4611, 4800, 4801, 4803, 4615 £4-00.
PAM 600S to 822F £4-00.
PETO SCOTT. Prices on request.
PHILCO 1019, 1020, 2021 £4-12½. 1029, 1030, 1035, 1036, 1040, 1050, 1060 £4-12½.
PHILIPS 11TG190 to 24T301 £5-90. 1768U to 2196U Rewind £4-75 (old unit required).
PILOT PT450, 452, 455, 650, PT651, P60A, P61 £4-00.
PYE V200, V400, 200LB, 210, 220, 300F, 300S, 310, 210S, 410, 510, 530, 600, 620, 630, 700 A or D, 710 A or D, 830 A or D or LBA £4-00. 11U Series, 11U-P/NO, AL21003, 21F to 61. Part Nos. must be given when ordering Pye LOPTS £4-00.
REGENTONE 197-198, 298, TV402, TV401, TV501, TV502 £4-50.
R.G.D. 626, 627, 628, 726, RV202, RV302 £4-50.
SOBELL 1000DS, 1002DS, 1005DS, 1010DST, 1012, 1013, 1014, 1018, 1019, 1020, 1021, 1032, 1033, 1038, 1039 £4-25.
STELLA T1011U to 2149A £5-90.
ULTRA 1770, 2170, 1772, 1782, 1782, 1771, 2171, 1775, 2175, 1774, 2174, 1773, 2137, 1980c, 1984c, 100c, 200c, 2380, 2384, 1984, 1985, 1986, 1980, 1980a, 1780, 2180, 2181, 2183, 2182, 1871, 1783, 6600, 6625, 6626, 6628, 6632, 6642 etc. £4-00.
 We can rewind most LOPT £4-75.

Post and Package 26p. C.O.D. 30p extra.

LINE OUTPUT TRANSFORMER INSERTS ONLY

BUSH TV92-TV93, TV94-TV95-TV96-TV97, TV98, TV100, TV101, TV103, TV104, TV105, TV106, TV108, TV109, TV110, TV113, TV115, TV115R, TV115c, 123, 125, 128 £2-75. Complete with heater windings. TV75, TV85 £2-75.
DECCA DR95, DR101, DR202, DR303, DR404, DR505, DR606 £2-75.
EMERSON E700, E701, E704, E707, E709, E710, E711, Portarama £1-87½.
FERGUSON 204T, 205T, 206T, 214T, 235T, 236T, 244T, 245T, 246T £2-00.
FERRANTI 14T2, 14TC, 14T3F, 14T4, 14T4F, 14T5, 14T6, 17K3, 17K3F, 17T3, 17T3F, 17K4F, 17K6, 17SK6, 17T4, 17T4F, 17T5, 17T6, 21K6, 21K6V £1-87½.
INVICTA T118, T119, T120 £2-50.
KB PV40, MV100, OF100, PV100, NV40, NF70, OV30, QV10, QV30 £2-00 pair.
PETO SCOTT 1416, 1418, 1419, 1422, 1423, 1716, 1719, 1720, 1722, 1723, 1724, 1725 £1-47½.
PYE V4, VT7, CTM4, TCM7 £2-50.
REGENTONE 10-4, 10-6, 1021, 17-18, 10-12 £1-75. T176, TT7, 191, 192 £1-87½.
R.G.D. Deep 17, The 17, 590, 600, 606, 611, 710, 723 £1-75.
 Guarantee. Post and Package 26p. C.O.D. 30p extra.

NEW REPLACEMENT L/OP/TX

MURPHY £5-90 26p P.P.
 V310 TO 789

REPLACEMENT DROPPERS

Philips Type 30+125+2-85 62½p. P.P. 7p.
 Ferguson, H.M.V., Marconi, Ultra 800 & 850 Series (Convertible) 37+31+97+26+168. 62½p. P.P. 7p
 As above 85 series (Dual Standard) 14+26+97+173 62½p each. P.P. 7p

HIGH VOLTAGE PULSE CERAMICS

10, 15, 22, 33, 68, 82, 100, 120, 140, 155, 180, 220, 250pf. 7½p. P.P. 3p

T.V. CANNED ELECTROLYTICS

64-100, 450v. £1-12½ each. P.P. 17p
 100-200, 275v. 90p each. P.P. 17p

T.V. CANNED ELECTROLYTICS

100-200, 350v. £1-12½ each. P.P. 17p	150-100-100-100-150
100-200-60. 17p	320v. £1-99 each. P.P. 17p
300v. £1-12½ each. P.P. 17p	200, 350v. 75p each. P.P. 17p
100-300-100-16. 17p	200-200-100.
275v. £1-35p each. P.P. 17p	350v. £1-89 each. P.P. 17p
100-400 275v. 95p each. P.P. 17p	300-300, 300v. £1-89 each. P.P. 17p
100-400-16. 17p	125+200+100+32-275v. £1-40
275v. £1-30 each. P.P. 17p	400+400-350v. £2-21

POWER RESISTOR SECTIONS

These wirewound sections enable you to build up any Mains Dropper to your requirements. A central 2BA hole is provided for mounting.

Ohms 7, 9, 10, 12, 14, 17-5, 20. All at .7A	19p each
Ohms 22, 25, 28, 30, 33, 36. All at .7A	24p each
Ohms 40, 47, 52, 56, 60, 63, 66, 75, 87, 100 at .3A	19p each
Ohms 120, 140, 160, 180, 200, 220, 250, 270 at .3A	24p each
Ohms 300, 350, 400, 470, 560, all at 12A	19p each
Ohms 726 at .15A	24p each
K Ohms, 1 K ohm at .1A	19p each
K Ohms, 2 (-07A)	24p each

Postage each section 3p

**WE CAN STILL SUPPLY PARTS FOR THE CONSTRUCTOR
 625 RECEIVER. S.A.E. FOR REQUIREMENTS**

CALLERS WELCOME. But to avoid disappointment please phone to check that the items you require are in stock. All new components inserts are guaranteed for three months from the date of invoice subject to the breakdown being due to faulty manufacture or materials. S.A.E. all enquiries.

**Dept. "R" D. & B. TELEVISION (Wimbledon) LTD. 80 MERTON HIGH STREET, S.W.19
 01-540 3513 01-540 3955**

TELEVISION

SERVICING · CONSTRUCTION · COLOUR · DEVELOPMENTS

VOL 21 No 7
ISSUE 247

MAY 1971

RAINBOW'S END

Some rainbows are said to terminate in a pot of gold, but the end of the colour television rainbow is an amalgam of glass and metal known as the shadowmask tube. Since this emerged from the lab as a commercial proposition two decades ago improvements have been made and rival schemes to display colour TV pictures have failed to shake its seeming indisputable position as the only viable system we have.

But however dominant may be the shadowmask many of us still like to dream of a rainbow in the future which may be displayed on a flat picture-frame device using some solid-state techniques. For the moment though the shadowmask tube reigns supreme despite its mechanical complications, cumbersome neck iron-mongery, manufacturing difficulties, convergence problems and high cost.

Recently however a newcomer has gained a good deal of publicity as an alternative display device—the Trinitron manufactured by Sony (details of which were given in our September 1970 issue). This is essentially an up-dated version of the Chromatron of c.1950 and due to the advantages claimed must be taken seriously as a contender. It uses a single-gun assembly, has a higher efficiency (hence gives brighter pictures), simplifies convergence (dynamic convergence is reduced to two voltage adjustments), the tube neck is smaller in diameter (thus requiring less power for beam deflection) and—owing to the overall simplification—the tube is considerably cheaper to produce.

Despite all this there are reservations. It has been suggested that although results may be impressive using small screens the real proof of the pudding will only be obtained when comparative tests between Trinitron and shadowmask receivers of larger sizes can be made. Doubts are not allayed by the statement from Sony that they will only be making small-screen models, such as the 13-inch receivers recently demonstrated here.

As for the price factor, sceptics are given further ammunition in that these mini-receivers will be sold at around £200—not even substantially short of the cheaper large screen UK products and certainly nothing like a price breakthrough. As for how Sony intend to overcome the PAL patent situation (about which company spokesmen have so far maintained a Trappist silence) we have been promised an insight into the secrets during this month. We hope to report further in due course.

W. N. STEVENS, *Editor*

THIS MONTH

Teletopics	294
Direct-Reading Analogue/Digital Frequency Meter—Part 1 <i>by Martin L. Michaelis, M.A.</i>	296
Service Notebook <i>by G. R. Wilding</i>	303
Shadowmask Tube Faults <i>by Paul Silverhay</i>	304
Workshop Hints <i>by Vivian Capel</i>	308
DX—TV <i>by Charles Rafarel</i>	310
Servicing Television Receivers— Philips Style 70 Series <i>by L. Lawry-Johns</i>	311
Hi-Fi TV Sound Unit <i>by David Robinson</i>	314
Next-Generation TV Sets	318
Colour Receiver Circuits—Luminance Circuits <i>by Gordon J. King</i>	319
Using the Oscilloscope—Part 2 <i>by Keith Cummins</i>	322
Your Problems Solved	329
Test Case 101	331

THE NEXT ISSUE DATED JUNE
WILL BE PUBLISHED MAY 22

TELETOPICS



END OF SYLLABUS 48

THE Final examination in 1973 will be the last of the present style *Radio and Television Servicing Certificate* courses and examinations—known as Syllabus 48—conducted by the Radio Trades Examination Board and the City and Guilds of London Institute. This year sees the last Intermediate examination but in each case there will be one repeat for those failing at their first attempt. The last time the scheme was reorganised was in 1960 when Syllabus 47, *Electronic Servicing*, was established. Plans to introduce new courses to replace Syllabuses 47 and 48 were first proposed in 1963. They have now been finalised and are already in operation, the first examination at Part I level having been held last year. Under the new scheme the Radio and Television Servicing course is replaced by two separate courses, one at “craft” and the other at “technical” level. The aim has been to broaden the coverage to give students wider scope in their subsequent careers.

The “craft” level course is No. 433, *Radio, Television and Electronics Mechanics' Course*, and it is this one that is intended for the bulk of students who would previously have entered for the Syllabus 48 course. The new course is a four-year part-time one qualifying for the award of an *Advanced Mechanics' Certificate*. The specialist subjects such as monochrome and colour television circuitry are studied in the fourth year at Part III level.

The “technician” level course, No. 434, *Radio, Television and Electronics Technicians' Course* is intended for students who have the ability to approach the subject more academically and mathematically though retaining the practical approach to the servicing side. It is a five-year course and provides an opportunity to divide into specialist areas of electronics or radio and television at the fourth year. Candidates can obtain a *Technicians Certificate* at Part II level and a *Full Technological Certificate* at Part III.

With these changes the R.T.E.B. has altered its name to the Radio, Television and Electronics Examination Board, a new constituent member, the Electronic Components Board, having been elected.

Will all this mean more scope for the dabbler as those with their mint certificates disappear even faster than today into industry (did I hear someone ask “what industry?”)?

SATELLITE TV FOR UK?

The British Aircraft Corporation has submitted a plan for a communications satellite to serve the UK. One suggested use is for beaming TV programmes

to the more remote parts of Britain unable to receive normal transmissions: BAC reckon they could have a satellite in service for a quarter of the £60 million the BBC intends to spend on completing its u.h.f. coverage. The only snag is that the transmissions would presumably have to be at s.h.f. so that special converters would be required to process the signals before they could be fed to a standard television receiver. The satellite would orbit at 24,000 miles, covering the UK with a narrow beam, and could serve a number of communications purposes.

Mullard showed at the 1971 *Physics Exhibition* a colour receiver for s.h.f. (12GHz) television transmissions using a converter of the type described in our February 1971 issue (page 155). They point out that satellite transmissions offer the opportunity of getting country-wide TV coverage very quickly—estimating that a conventional broadcasting system could take up to 25 years to install in a country without a television system at all. Mullard are now talking about the possibilities of digital modulation at these microwave frequencies: something else new to cheer us up!

TRANSMITTER NEWS

The BBC-1 u.h.f. services have now started from **Belmont** Lincolnshire and from **Caradon Hill** and **Redruth**. The last two bring almost the whole of Cornwall and West Devon within reach of both BBC-1 and BBC-2. The Belmont and Caradon Hill BBC-1 services are on channel 22 (receiving aerial group A) while Redruth BBC-1 is on channel 51 (receiving aerial group B). All these transmissions are horizontally polarised.

The ITA has brought into service its **Bilsdale** transmitter, bringing Tyne Tees programmes to North Yorkshire on channel 29 with horizontal polarisation (receiving aerial group A).

The ITA has also now placed new contracts to speed up the supply of equipment for its first batch of relay stations. These stations and their estimated service dates are as follows: Reigate and Brierley Hill, Autumn 1971; Sheffield, Stoke-on-Trent (Fenton), Tunbridge Wells, Kilvey Hill, Bromsgrove, Guildford and Hemel Hempstead, Winter 1971-2; Keighley, Brighton and Malvern, Spring 1972. These stations were to have come into operation last year but the suppliers ran into technical difficulties—in the development by a sub-contractor of the travelling-wave amplifier tubes which were to have been used. The new orders have been placed with a French company—Laboratoire General des Telecommunications—which already has available u.h.f. relay stations.

MULTI-PURPOSE TV SET

Toshiba are now marketing in Japan a domestic TV installation comprising a monochrome receiver with four-channel switching unit, inexpensive miniature vidicon-type cameras and the company's standard front-door interphone. This set up enables the viewer to monitor the front door and other rooms in the dwelling. When a caller pushes the front-door intercom button his or her picture appears at the corner of the set's screen as a quarter image—even if the set is switched off. A special attachment then enables communication with the caller via the household telephone. The four-channel switching unit allows up to four of the cameras to be simultaneously linked to the monitor, each camera image taking up a quarter of the screen. A quarter image can be expanded to cover the entire 14in. screen area by using the set's contrast control. The receiver can also be used in conjunction with a videotape recorder to record and replay off-air television programmes.

TV HISTORY

The recent get together at the ITA gallery mentioned by our editor last month to view TV pictures recorded by John Logie Baird from his 30-line TV camera on a 78 r.p.m. wax disc was attended by several of the pioneers of TV including P. J. Packman who built the original two Baird Televisor prototypes at Plessey in 1929. Which all goes to show how rapid has been the development of TV to its present advanced state. The wax recording was sold at Selfridges in 1935 under the Phonovision label. We learnt incidentally that Selfridges was one of the organisations who helped sponsor Baird's early experiments. A recent acquisition by the gallery is a Bush receiver of 1932 vintage. This—another mechanical-scan receiver—uses a Kerr cell and a mirror-drum scanning system. We look forward to another party when this is put into working order!

NEW DUAL-BEAM SCOPE

Tequipment have added a new general-purpose dual-beam oscilloscope, Model D51, to their range. Features include 6×10cm. display area, d.c. to 6MHz bandwidth for channel 1 and d.c. to 3MHz channel 2, and 10mV/cm. sensitivity from d.c. to 2MHz. The price is £98.

GLOOM ALL ROUND

Programme production companies on both sides of the Atlantic are looking despondent in the present conditions of falling advertising revenues and spiralling production costs. Falling profits and in some cases even losses have been announced on this side of the Atlantic. In the US the problem has been considerably aggravated by the loss of cigarette advertising as a result of the Congressional ban which came into force on January 1st. This is estimated to have cost the industry some \$170 million, nearly 10% of its advertising revenue. All three major US networks are laying off staff, trimming production budgets and cutting down on prestige documentary and news programmes. The National Broadcasting Company has discharged over 70 staff, the American Broadcasting Company 300 while the Columbia Broadcasting System intends to reduce its payroll by

15%. It will take a considerable turn-around in economic conditions before the days of licences to print money return, if in fact they ever will.

NEW CAMERA TUBES

Several new TV camera tubes were shown by Mullard at the *Electron Optical Systems Design Conference and Exhibition* at Brighton recently. The first is a Plumbicon tube, type 60MXQ, for use in colour cameras. Under low light level conditions in colour systems moving objects sometimes appear to be followed by a coloured blur because the photoconductive layers in the three camera tubes used have different lags to different colours. The new tube uses a novel light biasing arrangement to prevent this. Light can by means of guides be directed on to the back of the target. In this way the operating point on the tube's characteristic can be moved away from the flattened part near zero to the steeper part where there is greater sensitivity and consequently a shorter lag. By careful adjustment of the light bias applied to the tubes in the camera each can be given the same lag value to avoid colour blur.

Two new vidicons were shown. The 7262A is a low-cost tube intended for industrial use. It has a resolution better than 500 TV lines and 10 lux illumination will produce a signal current of at least 150nA. With magnetic focusing and scanning, the measurements are 25.5mm. diameter and 130mm. length. The type 20PE11 vidicon is supplied complete with coils and is intended for use in miniature cameras for applications such as surveillance systems, non-broadcast film replay systems etc. The diameter is 17.7mm., resolution better than 400 TV lines and minimum signal current at 10 lux illumination 120nA. Focusing and deflection are magnetic. A separate-mesh version, the 20PE13, is also available.

Also on show was an intensifier vidicon tube, type 50MXQ, consisting of a vidicon coupled to a single-stage image intensifier by fibre optics to form a single unit. This tube will give high-quality TV pictures under half-moonlight conditions.

VIDEOCASSETTES

While the EVR partnership is busy building up its library of cassette recordings—on special 8.75mm. film—for TV set playback via a teleplayer incorporating a flying-spot scanner at its Basildon factory opened last Summer, Associated Television has now announced that it is planning to go into the production of programmes on videotape cassettes in conjunction with the American Broadcasting Corporation and hopes to have its first productions completed by the end of this year. Sir Lew Grade, chief executive of ATV, claims that by using TV production methods a play could be videotaped in a few days and the costs covered by hiring the tape to a small market at a high price. He envisages a world-wide market of about two million in three to four years time, paying around £1 each to hire a tape for a couple of days. EVR on the other hand are talking about a potential market of £400 million by 1980. Clearly a lot of investment and some high hopes are about: in the present economic climate however one wonders just how many people how soon can be persuaded to take to selecting and watching their own TV programmes, given the costs involved.

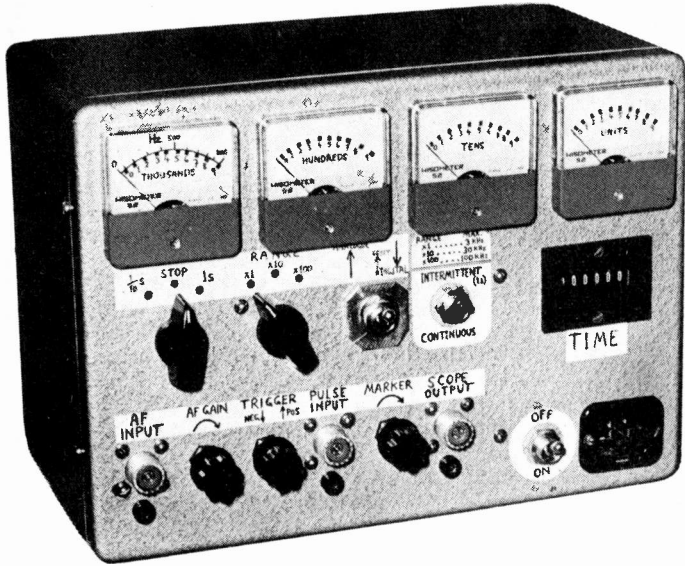

FREQUENCY METER

MARTIN L. MICHAELIS, M.A.

PART 1

ALTHOUGH serving many purposes on its own this instrument is primarily intended as an auxiliary unit for use in conjunction with any conventional oscilloscope, e.g. the Videoscope MV3 for which we have already presented a number of accessory units. The design described in this constructional feature is the most ambitious of these, serving all normal requirements for accurate frequency measurements and time calibration of sinusoidal and pulsed waveforms up to well in excess of 100kHz.

At the same time this feature gives us the opportunity to continue our practical introduction to integrated circuits. Modern digital i.c.s have made a high-resolution digital frequency meter a feasible proposition for the average constructor with good experience of conventional television equipment. Previous features have been concerned with i.c. operational amplifiers which are essentially analogue devices. Some of these are used again in the present design but most of the i.c.s used are digital types.

Conventional direct-reading digital frequency meters employ numeral indicator tubes of some kind,

one for each display digit. Each such indicator tube requires decoder and driver i.c.s in addition to the actual counter system and its start/stop circuitry. This complexity is the reason for the rather high cost of standard commercial digital meters. The design presented here employs a novel method of digital read-out using one small moving-coil meter for each display digit. Such meters are readily available at less than the price of a numeral indicator tube and do not require complex decoders and drivers nor a high-voltage power supply. They can be operated directly from the counter section via a simple network consisting of a few resistors and diodes. The savings realised in this manner have been reinvested in giving the instrument a variety of valuable extra features. The final result is a design costing about the same as a contemporary commercial digital meter but having much greater versatility, in particular for direct utilisation in conjunction with an oscilloscope.

The waveforms we desire to examine at various points in a piece of television equipment may range from low amplitudes of a few millivolts to high levels

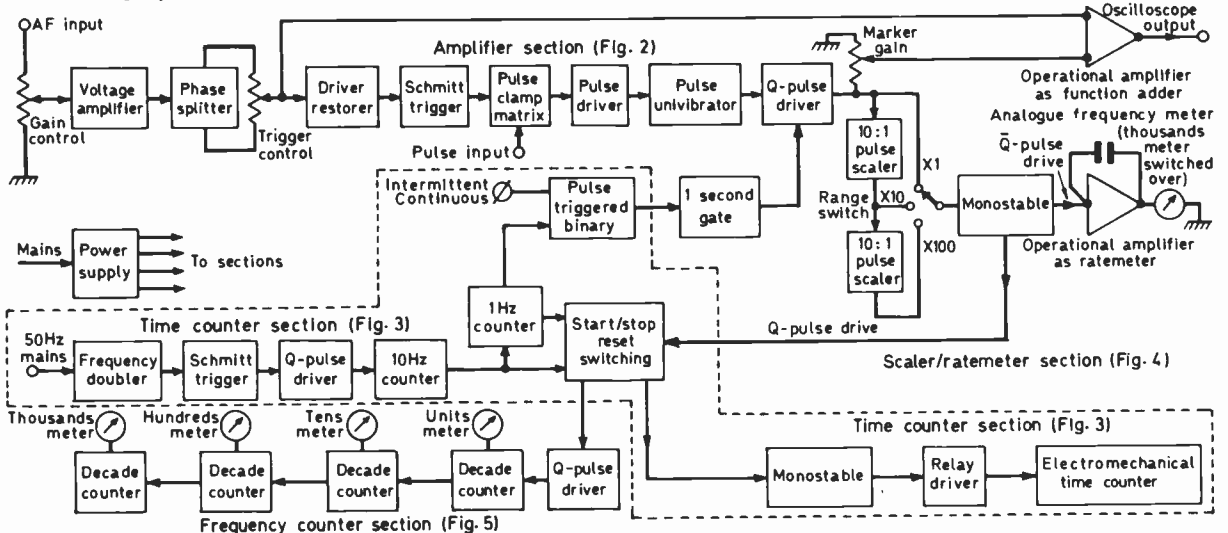

Fig. 1: Block diagram of the complete direct-reading frequency meter.

of 100V and more. They may already be sharply pulsed as required for triggering the counter section of a frequency meter, or they may be almost sinusoidal, devoid of any marked pulse flanks. Furthermore the waveform may be complex within one repetition cycle, with several returns to or even crossings of the zero voltage line. Such cases imply the presence of harmonics of the fundamental repetition frequency with much greater amplitudes than the fundamental. It is then necessary to define the counter trigger point, i.e. whether we are going to measure the fundamental frequency or a pronounced harmonic. The choice must be made unambiguously. These considerations make it clear that the versatility of a frequency meter stands or falls with the quality of its signal-processing amplifier. This must possess adequate gain, good bandwidth, polarity selection and trigger-level selection.

Amplifier Features

The complete amplifier is shown along the top of the block diagram Fig. 1. The a.f. input accepts any waveform which is fed via a conventional gain control potentiometer to a high-gain voltage-amplifier stage. This stage drives a phase splitter producing same-polarity and inverted-polarity amplified replicas of the input waveform. A potentiometer connected between these two signal phases gives continuous control from maximum amplitude in one phase through zero to maximum amplitude in the other, the selected phase and amplitude being used to drive a d.c. restorer ahead of a Schmitt trigger stage. The latter fires on the transition of a definite d.c. potential and drops back again when the signal excursion recrosses this potential, producing an accurate squarewave from any arbitrary input waveform regardless of shape or frequency.

This pulsed waveform is then fed to a pulse clamp matrix. A second external input here permits direct injection of already pulsed signals. The output of the pulse clamp matrix is used to fire a pulse univibrator via a pulse driver, producing one accurate narrow pulse for each cycle of the input waveform. This pulse train is fed via a gated Q-pulse driver to the counter section which will be described later.

To complete the amplifier description, two outputs are also taken to an i.c. operational amplifier feeding the oscilloscope output. One of these drives is the original input waveform from the phase splitter and the other the Q-pulse driver output which is taken via a marker gain control. The purpose of the i.c. operational amplifier is to add these two signals algebraically without mutual interference or distortion. Apart from this the amplifier circuit employs entirely conventional transistor stages.

Marker Display

If the marker gain control is set to zero only the amplified input waveform appears at the oscilloscope output, with the same shape and polarity but boosted by a factor of exactly 20. If the gain and trigger controls are not turned up sufficiently the oscilloscope display will not change when the marker gain control is turned up because the Schmitt trigger is not firing and therefore there is no output present at the Q-pulse driver. With the marker gain control turned up there will come a point whilst turning up the gain and

trigger controls where negative spikes are suddenly seen superimposed on the displayed waveform. These indicate that the pulsing system is now firing and exactly mark the points on each cycle of the input waveform at which the Schmitt trigger fires. If the waveform is complex, with many transitions or approaches to the zero line in one complete cycle, the a.f. gain and trigger controls can be judiciously adjusted to make the marker spikes appear only at the desired points but unambiguously at all such points. Any "misses" are clearly evident in the oscilloscope display so that corresponding false or erratic frequency measurements are precluded.

Preamplification

The entire amplifier chain not only converts the input signals into a form which can be handled by the counter section but also serves as a general-purpose oscilloscope preamplifier. This may be used to boost the sensitivity of the oscilloscope, with the marker gain control turned to zero if the marker spikes interfere with the display. This does not stop the frequency meter functioning.

With the a.f. gain and trigger controls set to maximum 15mV r.m.s. sinewave or about 22mV peak of an arbitrary waveform are required at the a.f. input to fire the pulsing section. Any larger amplitude up to 100V peak is acceptable by turning down the a.f. gain control accordingly. The a.f. gain control should be adjusted so that the pulsing section just fires securely, indicated by the appearance of the marker spikes without any misses. This means that the signal voltage at the slider of the a.f. gain control is always about 22mV peak giving a fixed peak-to-peak amplitude of 1 to 2V at the oscilloscope output. The Y-gain control of the oscilloscope must be set to a corresponding fixed value and left there, all necessary gain control to suit different input signal amplitudes being effected with the frequency meter a.f. gain control. The effective sensitivity at the frequency meter a.f. input is then about 25mV/cm. with the a.f. gain control at maximum.

The input impedance is only about 50k Ω and the shunt capacitance considerable. Many points in television equipment would not tolerate this loading, necessitating the use of the oscilloscope signal probe at the frequency meter input. The effective sensitivity at the tip of the Videoscope MV3 signal probe connected to the frequency meter a.f. input with the a.f. gain control at maximum is then the same as if the signal probe is connected directly to the Y-input of the Videoscope MV3, but a peak signal amplitude of about 4V is required to fire the pulsing section. Very many waveforms in TV equipment exceed this amplitude. If smaller amplitudes are to be handled the i.c. preamplifier described in the November, 1970 and January, 1971 issues must be interposed between the signal probe and the frequency meter a.f. input. The full sensitivity figures as specified in the i.c. preamplifier description are then obtained.

It is necessary to use the i.c. preamplifier as a self-contained battery-operated input booster in this manner instead of incorporating an extra amplifier stage in the frequency meter because the latter method would lead to hum loop difficulties causing erratic firing of the pulsing section. Quite low gain settings of the i.c. preamplifier suffice because the main purpose is to effect impedance matching, restoring the inherent gain of 20 in the frequency meter amplifier.

This gain is lost due to the impedance mismatch when the Videoscope MV3 signal probe is connected directly to the frequency meter a.f. input.

Scaler Section

The Q-pulse driver output of the amplifier section feeds the scaler section of the pulse counter system. The scaler performs range switching and consists of two 10:1 digital counter i.c.s. The pulses from the amplifier section are fed to the first one of these counters and exactly every tenth input pulse produces an output pulse which is fed to the second counter. Thus every hundredth amplifier output pulse produces an output pulse from the second counter. A switch selects either the amplifier output pulses directly or the output pulses of the first or second scaler stage.

Counter Driver

An i.c. monostable is used as counter driver. Its Q-pulse output is used to drive the digital frequency counter via the start/stop/reset switching network while its \bar{Q} -pulse output provides the correct polarity for driving the direct-reading analogue frequency

meter. The latter uses an i.c. operational amplifier connected as a pulse integrator. Integration is realised by using capacitive external feedback to the \bar{Q} -input of the operational amplifier instead of the purely resistive feedback with which we are already familiar for simple amplifying and adding applications.

Frequency Counter

The frequency counter consists of four further 10:1 digital counters in cascade. These decade counter stages function in exactly the same way as the two used in the scaler section so that we have six decade counter stages in cascade when both scaler stages have been introduced with the range switch. Evidently one million input pulses from the amplifier section are required in this range setting before the counter chain has counted through all possible states. The maximum pulse count capacity of this counter chain is 999,999, i.e. one less than a million pulses, the millionth pulse from the amplifier resetting all stages to zero. Further counting then continues from zero.

The four decade counter stages of the frequency counter differ from those of the scaler only in that they have one meter each connected to their Q-out-

★ components list

Resistors:

R1	10k Ω	R18	470 Ω	R35	1.5k Ω	R52	150 Ω	R69	33 Ω	R86	47k Ω	R102	680 Ω
R2	470k Ω	R19	2.2k Ω	R36	470 Ω	R53	820 Ω	R70	12k Ω	R87	22k Ω	R103	470 Ω
R3	100k Ω	R20	56k Ω	R37	560 Ω	R54	47 Ω	R71	10k Ω	R88	10k Ω	R104	680 Ω
R4	27k Ω	R21	1k Ω	R38	100 Ω	R55	270 Ω	R72	1.5k Ω	R89	4.7k Ω	R105	680 Ω
R5	4.7k Ω	R22	4.7k Ω	R39	1k Ω	R56	220 Ω	R73	10k Ω	R90	100 Ω	R106	470 Ω
R6	390k Ω	R23	150 Ω	R40	24k Ω	R57	560 Ω	R74	47k Ω	R91	100 Ω	R107	680 Ω
R7	1k Ω	R24	1k Ω	R41	1M Ω	R58	100 Ω	R75	22k Ω	R91A	27 Ω	R108	680 Ω
R8	8.2k Ω	R25	2.7k Ω	R42	470 Ω	R59	100 Ω	R76	10k Ω	R92	43 Ω 5W	R109	470 Ω
R9	1k Ω	R26	5.6k Ω	R43	150k Ω	R60	680 Ω	R77	4.7k Ω	R93	43 Ω 5W	R110	680 Ω
R10	2.2k Ω	R27	56k Ω	R44	150k Ω	R61	47k Ω	R78	47k Ω	R94	330 Ω 1W	R111	680 Ω
R11	5.6k Ω	R28	100 Ω	R45	150k Ω	R62	2.7k Ω	R79	22k Ω	R95	330 Ω 1W	R112	1k Ω
R12	5.6k Ω	R29	470 Ω	R46	680k Ω	R63	5.6k Ω	R80	10k Ω	R96	220 Ω	R113	3.9k Ω
R13	2.2k Ω	R30	47k Ω	R47	1.5k Ω	R64	68k Ω	R81	4.7k Ω	R97	10k Ω	R114	24k Ω
R14	1k Ω	R31	56k Ω	R48	10k Ω	R65	10k Ω	R82	47k Ω	R98	180 Ω	R115	120k Ω
R15	470k Ω	R32	10k Ω	R49	1M Ω	R66	10k Ω	R83	22k Ω	R99	68k Ω	$\frac{1}{2}$ W 10% unless otherwise stated	
R16	4.7k Ω	R33	2.2k Ω	R50	10k Ω	R67	12k Ω	R84	10k Ω	R100	470 Ω		
R17	100k Ω	R34	27k Ω	R51	4.7k Ω	R68	33 Ω	R85	4.7k Ω	R101	680 Ω		

Potentiometers:

VR1	50k Ω log. P	VR8	2.5k Ω lin. MS	VR15	10k Ω lin. MS	VR22	25k Ω lin. MS	VR27	10k Ω lin. MS
VR2	50k Ω lin. P	VR9	25k Ω lin. MS	VR16	50k Ω lin. MS	VR23	10k Ω lin. MS	P, potentiometer for panel mounting; MS, miniature skeleton preset	
VR3	250k Ω lin. MS	VR10	10k Ω lin. MS	VR17	50k Ω lin. MS	VR24	50k Ω lin. MS		
VR4	10k Ω lin. MS	VR11	1k Ω lin. MS	VR18	25k Ω lin. MS	VR25	50k Ω lin. MS		
VR5	5k Ω lin. MS	VR12	50k Ω lin. MS	VR19	10k Ω lin. MS	VR26	25k Ω lin. MS		
VR6	10k Ω lin. MS	VR13	50k Ω lin. MS	VR20	50k Ω lin. MS				
VR7	2.5k Ω log. P	VR14	25k Ω lin. MS	VR21	50k Ω lin. MS				

Diodes:

D1-D7	BAY20	D10	BAY20	D13	BYY35	D19	ZX5-1	D22	ZD12	D25	BAY20
D8	OA91	D11	BYY32	D14-D17	BYY33	D20	BYY33	D23	ZD12	D26-D39	OA95
D9	BAY20	D12	BYY32	D18	ZX5-1	D21	BYY33	D24	OA95	D40	BAY20

Alternatives:

BAY20	Any small silicon diode	BYY33	About 250V p.i.v. $\frac{1}{2}$ A	ZX5-1	5V 1W zener
BYY32	About 100V p.i.v. $\frac{1}{2}$ A	BYY35	About 400V p.i.v. $\frac{1}{2}$ A	ZD12	12V 750mW zener

Transistors:

Tr1	BC108C	Tr4	2N1613	Tr7	BSY76	Tr9	2N1613	Tr11-Tr17	2N1613
Tr2	BSY76	Tr5	2N1613	Tr8	2N1613	Tr10	BC107B	Tr18	BC107B
Tr3	BC108B	Tr6	2N1613						

puts via resistor-diode networks to read all states from 0 to 9 for each stage. This read-out network could have been provided for the scaler stages too but is not required within the functional concept of this unit, so that it has been omitted in the scaler section. The scaler stages are thus known as *blind decades*, because there is no way of telling which intermediate state between 0 and 9 has been reached at any instant. The frequency counter stages are known as *decimal read-out decades*. The term *scaler* already implies a blind decade, or a blind divider with some other ratio. It scales the digital value of the read-out counter stages. For example, the value of one count in the third read-out stage is 100 pulses if no scaler stages are in circuit but 1000 or 10,000 respectively if one or both scaler stages are in circuit. The values of 1 count in the first read-out stage are 1, 10 or 100 pulses for these respective cases.

The four meters are called the units, tens, hundreds and thousands meter, respectively. These designations refer to the pulse value of one count when no scaler stages are in circuit. The range switch is marked $\times 1$, $\times 10$ and $\times 100$ in the settings placing no, one or both scaler stages respectively in circuit. The pulse value of one count registered on any meter

is the meter designation value multiplied by the range switch setting.

Each meter possesses a scale with ten discrete marks numbered 0 to 9. Each count registered by the meter causes the pointer to jump abruptly to the next higher discrete mark. When the reading 9 has been reached after successive counts registered in this manner, the next count abruptly resets the meter to the 0 mark and at the same time causes a count to be registered in the next higher meter. When all four meters have reached 9 in this manner the next count registered by the first meter resets all meters to 0 and the entire process is repeated indefinitely if counting is continued.

All meters retain their clocked-up readings for any length of time until the unit is switched off or reset with the manual reset function or of course until further pulses arrive from the amplifier.

Time Counter

It is necessary to provide an arrangement which establishes that the clocked-up count is not merely an arbitrary pulse count but rather a direct digital read-out of frequency. We have four decade meters thus

Capacitors:

C1	1 μ F	500V F	C23	50 μ F	25V EI	C45	1 μ F	100V F	C67	0.068 μ F	1kV P
C2	1 μ F	500V F	C24	100 pF	500V C	C46	560 pF	500V C	C68	0.1 μ F	250V F
C3	100 μ F	25V EI	C25	100 μ F	25V EI	C47	1 μ F	100V F	C69	0.1 μ F	250V F
C4	100 μ F	25V EI	C26	0.1 μ F	500V F	C48	22 pF	500V C	C70	2500 μ F	35V EI
C5	0.1 μ F	100V F	C27	2200 pF	500V C	C49	0.1 μ F	100V F	C71	0.1 μ F	100V F
C6	100 μ F	12V EI	C28	68 pF	500V C	C50	0.1 μ F	100V F	C72	2500 μ F	15V EI
C7	1000 μ F	35V EI	C29	1 μ F	100V F	C51	0.1 μ F	100V F	C73	2500 μ F	15V EI
C8	0.1 μ F	100V F	C30	0.1 μ F	500V F	C52	0.1 μ F	100V F	C74	0.1 μ F	100V F
C9	1 μ F	100V F	C31	5 μ F	25V EI	C53	0.1 μ F	100V F	C75	2500 μ F	35V EI
C10	1 μ F	100V F	C32	100 μ F	25V EI	C54	0.1 μ F	100V F	C76	1000 μ F	35V EI
C11	1 μ F	100V F	C33	100 μ F	25V EI	C55	0.1 μ F	100V F	C77	1000 μ F	15V EI
C12	1000 μ F	25V EI	C34	0.1 μ F	100V F	C56	0.1 μ F	100V F	C78	0.1 μ F	100V F
C13	100 μ F	25V EI	C35	0.1 μ F	100V F	C57	0.1 μ F	100V F	C79	1000 μ F	35V EI
C14	0.1 μ F	100V F	C36	0.1 μ F	100V F	C58	0.1 μ F	100V F	C80	1000 μ F	15V EI
C15	1 μ F	100V F	C37	0.1 μ F	100V F	C59	0.1 μ F	100V F	C81	0.1 μ F	100V F
C16	100 μ F	25V EI	C38	100 μ F	12V EI	C60	0.1 μ F	100V F	C82	100 μ F	25V EI
C17	0.1 μ F	100V F	C39	4.7 μ F	100V F	C61	0.1 μ F	100V F	C83	0.022 μ F	100V F
C18	100pF	500V C	C40	0.1 μ F	100V F	C62	0.1 μ F	100V F	C84	0.1 μ F	100V F
C19	0.1 μ F	100V F	C41	0.1 μ F	100V F	C63	100 μ F	12V EI	C85	0.1 μ F	100V F
C20	470pF	500V C	C42	0.1 μ F	100V F	C64	0.1 μ F	250V F	C86	0.1 μ F	100V F
C21	0.1 μ F	100V F	C43	0.1 μ F	100V F	C65	2500 μ F	35V EI			
C22	100 μ F	25V EI	C44	0.1 μ F	100V F	C66	0.068 μ F	1kV P			

F, plastic film; EI, electrolytic; C, ceramic; P, paper

Integrated circuits:

IC1	MC1709CG	Motorola	IC6	MC838P	Motorola	IC11	BP90	Bi-Pak
IC2	BP90	Bi-Pak	IC7	MC851P	Motorola	IC12	BP90	Bi-Pak
IC3	BP90	Bi-Pak	IC8	MC1709CG	Motorola	IC13	MC850P	Motorola
IC4	MC851P	Motorola	IC9	BP90	Bi-Pak			
IC5	MC838P	Motorola	IC10	BP90	Bi-Pak			

Miscellaneous:

F1	0.5A fuse		counter, 4-6 digits,	S4	DPST toggle
M1-M4	Moving-coil meters		approximately 24V,	S5	SPDT toggle
	500 μ A		100mA, maximum	T1	Mains transformer
P1, P3, P5	Coaxial sockets		about 25 counts per		12-0-10-12-15V
P2, P4, P6	Ground sockets		second		twice 0.35A
P7	Three-pole mains input	S1	3-pole 3-way ceramic		Five-control knobs, cabinet, boards
	socket	S2	2-pole 3-way ceramic		etc.
Rly1	Electromechanical	S3	DPDT toggle		

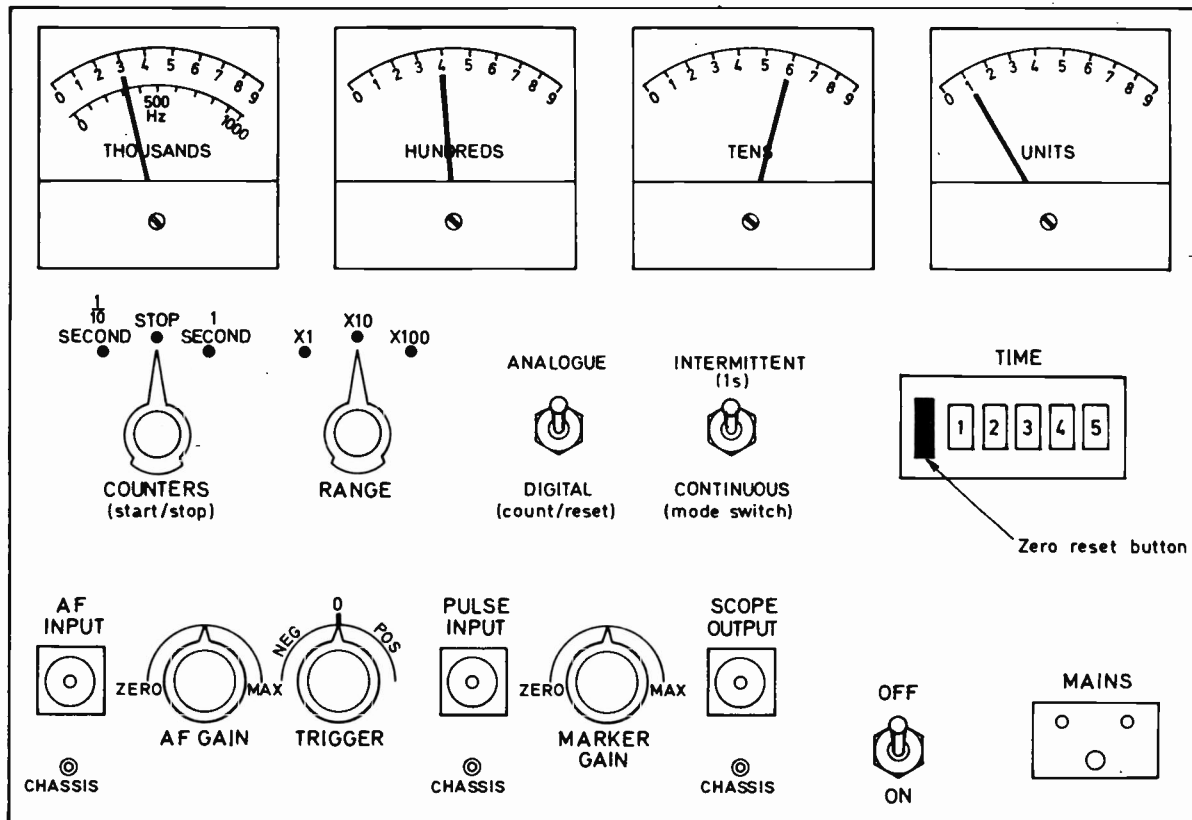

Front panel layout, showing the disposition of the various controls.

four significant figures, so the possible resolution is 0.01% which is *vastly superior* to any analogue meter reading. But it is important to distinguish between resolution and absolute accuracy. To measure a frequency in this way we must count pulses for a definite—preferably decimal—time period and the absolute accuracy is determined by the accuracy of the time period generator (provided the resolution is at least as good). The 50Hz a.c. mains frequency is used as the time standard in this instrument. The national grid system is slaved to a crystal reference generator which is controlled in turn by astronomical or atomic time standards, but short period drifts are common with fluctuating loading. The instantaneous mains frequency may differ by up to $\pm 0.5\%$ from the nominal 50Hz value, but is much closer to 50Hz for most of the time. This is the absolute accuracy of the digital frequency metering function with our design.

The time counter section consists of an unsmoothed full-wave rectifier producing 100Hz half-cycles from the mains transformer, followed by another Schmitt trigger to pulse these half-cycles, then a Q-pulse driver and finally two decade scaler stages in cascade producing time pulses at exact intervals of 1/10 second and 1 second respectively. These are selected by the start/stop/reset switching network of the frequency pulse counter section.

Time Gating

Two pulse counting modes are possible with this instrument. In the first mode the time counter chain and the pulse counter chain are essentially independ-

ent. They are started and stopped together with the three-position start/stop counter switch, in whose centre setting both counters are stopped. The pulse counter is operating in either the left or right setting of the switch. The time counter is counting tenths of a second in the left setting or seconds in the right setting. A separate count/reset switch (marked analogue/digital for reasons given later) is provided for the pulse counter while the time counter possesses a mechanical reset button on the electromechanical counter. If these reset controls are not actuated the clocked-up pulse and time counts are held indefinitely when the start/stop counter switch is moved to stop and counting is continued from the existing reading when it is moved again to one of the counting settings. *To avoid spurious counting errors reset and range selection should always be effected in the stop setting.*

The simple counting mode just described is obtained when the mode switch is set to *continuous*. The second position of the mode switch is marked *intermittent*. This brings a pulse-triggered binary i.c. into circuit, driven by the one-second output pulses of the time counter. Its Q-output actuates the one-second gate which cuts on and cuts off the Q-pulse driver at the output of the amplifier section for alternate exact seconds. Thus pulse counting now takes place for one second, the meters then halt with the attained reading for the next second, counting is continued for the third second and so on as long as the start-stop switch remains in one of the counting settings.

When the mode switch is set to continuous the pulse-triggered binary is disabled in such a manner that it holds the one-second gate permanently open

and all pulses from the amplifier section get through to the counter system.

Digital Frequency Measurements

The intermittent mode must be used for making digital frequency measurements. After adjusting the a.f. gain and trigger controls in the amplifier section with reference to the waveform and marker spike display on an oscilloscope to suit the input signal, switch the count/reset switch (labelled analogue/digital, the count setting being the digital position) to digital and observe the counting taking place on the meters during alternate seconds when the start/stop switch is in the one-second counting position. Return this switch to stop at any time during one of the non-counting seconds when the meter pointers are at rest. Then reset the meters to zero by briefly moving the count/reset switch to the upper analogue (reset) position and then down again to the lower digital position.

All is now ready to take a reading. Move the start/stop switch to the one-second counting position. Nothing happens until the first second has elapsed and a count is registered by the electromechanical time counter. At this instant the pulse counter meters commence to count. They stop again after exactly one second, coincident with the next one-second count registered by the electromechanical time counter. The start/stop switch must now be returned to stop at any convenient instant within the next second, before the pulse counter meters resume counting. The clocked-up count is held indefinitely by the meters and since it represents a pulse count for exactly one second it is a direct reading of the frequency in Hz. To obtain the frequency in Hz read the decimal values of the counts on the meters and multiply by the range switch setting.

It is not possible to use an electromechanical pulse counter in the frequency metering section because such a device is far too slow. The purpose of the one-second gating system is to get a quick frequency reading within two seconds by counting out the cycles of the input waveform directly for exactly one second. Since the design frequency limit is in excess of 100kHz extremely fast response is required. The i.c. decade counters can deal with frequencies up to tens of MHz if necessary. The read-out meters cannot respond faster than an electromechanical counter but this does not matter because they are not required to accumulate and store the count. This function is performed by the i.c. decade counters whose Q-outputs give the binary-coded total count at all instants and thus statically as soon as the counter has stopped. The Q-output voltages are fed via resistor-diode decoder networks to the respective meters so that these immediately take up the correct readings and stay put there when the counter has stopped.

Whilst the counter is counting the meter pointers sweep periodically if the frequency is low, quiver near midscale if the frequency is moderate, or appear to be stationary at midscale if the frequency is high. Since the actual frequency is progressively lower by powers of ten along the counter decade chain the last meter may be stepping, the penultimate one sweeping and the others quivering or hovering near midscale. This is of no significance: all meters go to the correct readings as soon as the counter stops, correct to 1Hz in 10kHz as far as possible resolution is concerned.

The one-second intermittent counting action is essential in order to realise the inherently possible resolution within a count of one-second. It is not possible to start and stop the counter manually with the necessary time precision because human reaction time and switch actuation delay amount to a random time fluctuation error of at least 1/5 second. To obtain the same resolution of 0.01% with this random uncertainty it would be necessary to count for ten thousandths of a second, more than half an hour! Any considerably shorter counting time would give an effective resolution hardly better than a simple analogue frequency meter, so that the outlay for the more advanced digital operation would be rather pointless. Thus, the intermittent counting action is crucial: only an automatic gating system can time a one-second count with the necessary accuracy.

A simple electromechanical counter is adequate for the time counter read-out because only tenths or full seconds have to be counted here. Electromechanical counters with an upper speed rating from 15 to 25 pulses per second, four or more display digits and a mechanical reset button are readily available. Almost any type within these ranges is suitable. The circuit has been designed using a counter with a 24V d.c. solenoid. The resistance is not critical but should not be less than about 200Ω. If a higher voltage solenoid is used the power supply and the voltage rating of Tr15 in Fig. 3 must be changed to suit. The voltage rating of Tr16 must also be changed or R63 left returned separately to a 24V supply rail.

Statistical Pulse Counting

This instrument may be used as a pulse counter/timer for Geiger-Müller tubes and other nuclear radiation detectors, photocell counters and a variety of analogous applications. These uses have in common that the signal pulse trains do not have a definite frequency but only an average frequency which is more accurately established the longer the period of counting. Small numbers of pulses arrive at random intervals. If we are counting flashovers in a piece of electronic equipment the statistical distribution will obviously be determined by a number of factors other than chance. But certain kinds of statistical pulse distribution are determined purely by chance. This is true for all nuclear radiation detectors under proper operating conditions. This type of chance distribution is characterised by the *square root law* which states that if we want a result giving the long-term average frequency accurate to 1 part in N , we must count N^2 pulses. Conversely, the uncertainty in a count of N pulses is \sqrt{N} . If we want a typical confidence level of 1% we must wait until ten thousand pulses have arrived which may take seconds, minutes or even several hours. Thus a facility for prolonged counting for indefinitely long timed periods is essential for any versatile frequency meter/counter. This facility is here given by the *continuous* mode.

If the measurements involve studies of the statistical frequency with which given audio or video waveforms exceed predetermined amplitude levels the a.f. gain and trigger controls in the amplifier section can be set to perform the required amplitude discriminator action with an accuracy sufficient for most equipment design requirements. If the signals are already essentially pulsed, such as for flashover-counting in high-voltage equipment using sensing resistors through which flashover current must flow, the signals

may be fed directly to the pulse input of the amplifier section. Definitely pulsed steady waveforms from TV equipment may also be fed to the pulse input for ordinary frequency measurements. For signals fed to the pulse input the oscilloscope display shows only the marker spikes, as a convenient means of verifying that the input amplitude is sufficient to fire the pulse univibrator. If not even pulsed signals must be fed to the a.f. input, with or without the oscilloscope signal probe and i.c. preamplifier discussed previously. The oscilloscope display then shows the input waveform with the marker spikes superimposed in the normal manner.

One-second frequency counting gives inadequate resolution if the frequency is very low. In contrast to a direct-reading analogue frequency meter there is no lower limit to the frequency range which the digital meter can handle. However if we want a resolution of 1 part in N we must wait for at least N pulses representing N cycles of the input waveform. For example, only frequencies of 100Hz and greater can be measured to an accuracy of 1% by the type of circuit used here. In principle we could measure low frequencies to any desired accuracy within a short time by using phase-sensitive comparator systems in conjunction with high-resolution timers, but such refinements are out of the question here since apart from circuit complexity they are highly dependent on input waveform. If we want greater resolution for very low frequencies we must count for periods longer than one second—preferably in decimal multiples—to obtain the necessary number of pulses. In practice it is reasonable to exploit the $\pm 0.5\%$ worst-case accuracy of the 50Hz mains frequency, which implies that we should make arrangements to clock-up at least 200 pulses for every digital frequency measurement. Thus we should count for ten seconds instead of one second if the input frequency is less than 200Hz or for 100 seconds if it is less than 20Hz. If we retain the one-second counting method accuracy deteriorates to $\pm 100/f\%$ where f is the actual frequency.

To count for exactly 10 seconds proceed exactly as described for the one-second counting method but make sure that the electromechanical time counter is zeroed at the start and return the start/stop switch to stop when the 20-second count has come up and before 21 comes up. Similarly to count for 100 seconds return to stop after time count 200. This evidently takes a few minutes. The 1/5 second human reaction delay is no longer a disadvantage so that straightforward continuous counting may be adopted, stopping manually when the 100 seconds count comes up. This halves the time required for a reading.

Analogue Frequency Read-out

The meter normally indicating the thousands digit of a digital read-out is switched over to the output of the integrating ratemeter operational amplifier when the count/reset switch is left in the upper analogue/reset position. The other three meters are thereby reset to zero and serve no function. The thousands meter carries a second scale with continuous calibration from zero to 1kHz.

Irrespective of the start/stop switch setting the meter now gives a direct analogue frequency reading with the usual accuracy limitation of a few percent inherent with any small moving-coil meter. The amplifier section controls must be operated in the

usual manner and the mode switch must be set to continuous. The range switch operates in the normal manner, i.e. the meter scale reading must be multiplied by the range switch setting. The meter range is thus 0-1kHz in the $\times 1$ range switch setting or 0-10kHz and 0-100kHz in the $\times 10$ and $\times 100$ range switch settings.

The analogue frequency meter reading serves various purposes. If only approximate frequency readings are required this mode is quick and follows every change of input frequency immediately without retouching any manual controls. It also provides a means for determining the proper range switch setting for a subsequent highly accurate digital reading. Any range setting which gives an on-scale analogue meter reading is satisfactory.

No damage is done in the analogue or digital mode settings if the input frequency is much too high in relation to the range setting. This makes the meter slam to full-scale stop in the analogue setting but internal limiters preclude meter damage. The digital counters count erratically if the frequency is too high in relation to the range setting. The frequency at the scaler output should not exceed 3kHz for proper counting which means that the thousands meter should not clock up more than 2 during a one-second count. This represents a safety margin of 2 to 3 in relation to the simple condition of first making sure that an on-scale reading is obtained in the analogue mode. Thus if the meter slams off scale with a particular range switch setting this range setting may nevertheless be used for the subsequent digital measurement if the analogue reading does not exceed quarter scale on the next higher range setting.

Resolution

The full theoretically obtainable resolution of 0.01% with four decade meters in the digital mode is not realisable in a one-second count because the thousands meter must not clock up more than 2 to 3 counts in a second. Thus the actual resolution of a one-second count is 1 in 3,000 or about 0.03%. This is of no significance for practical purposes however because the absolute worst-case tolerance of the mains frequency is $\pm 0.5\%$ and this sets the accuracy limit: the one-second count resolution is still greater by more than an order of magnitude. The theoretical resolution of 0.01% would be obtained with a ten-second count but this is irrelevant as far as absolute accuracy is concerned. The difference between 0.01% resolution and 0.03% resolution would be important only if a crystal oscillator instead of the mains frequency was used to feed the time-counter chain. Since the stability of a good crystal oscillator is better than these resolution figures it would determine the overall accuracy. These considerations led to the decision to use the mains frequency rather than a crystal master oscillator: the resolution is not good enough to warrant the expense of a crystal master oscillator. It would be necessary to provide at least six read-out meter stages to justify crystal control of the timing and the expense of these together with the crystal stage, thermostat and divider chain would bring the cost of the instrument well above the budgeted limit. It is however worth noting these points which play an important role in the design of commercial equipment.

CONTINUED NEXT MONTH

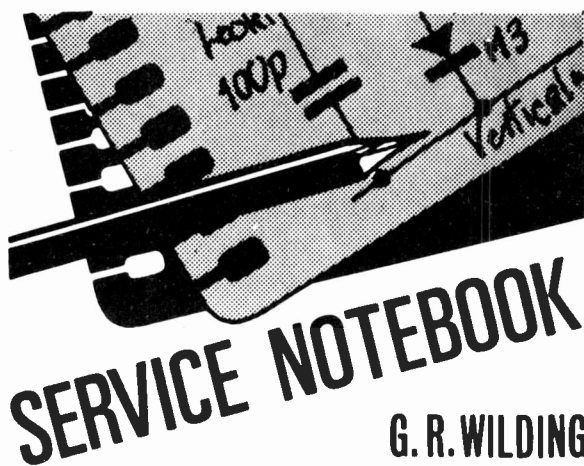

SERVICE NOTEBOOK

G. R. WILDING

Unusual HT Short-circuit

THE complaint with an elderly Bush 17in. receiver was that it had suddenly gone off while working. This we found to be due to an internal fuse blowing. A correct replacement similarly blew within a minute or so of switching on. Our first move after fitting another fuse was to connect an ohmmeter across the mains lead. This gave a normal reading so we then removed the c.r.t. base connector to see if the reading dropped to infinity, thereby indicating that at least there was no cold short-circuit across part of the heater chain due to heater-cathode breakdown in a valve or rectifier.

The meter reading obligingly dropped to infinity, so still leaving the c.r.t. base connector off we next checked for an h.t. short by connecting the testprods from the cathode of the BY100 rectifier (there had originally been a finned metal type in this receiver) to chassis. We obtained the usual large deflection as the electrolytics charged up, falling to a normal high reading. The practice of leaving the c.r.t. base connector off when checking for an h.t. short prevents the ohmmeter current flowing through the h.t. rectifier and then through the heater chain to give an erroneous impression that a short-circuit is present.

As there was no cold heater circuit or h.t. short-circuit the only thing to do was to plug in and watch for any signs of valve or component overheating. After switching on the valves warmed up very slowly—often the case in older receivers fitted with the original thermistor—and after a short while a hum came from the speaker. There was no sound or line whistle. Through a small aperture in the upright chassis however we could just see a resistor beginning to glow red, so we hastily switched off.

On removing the chassis we found this resistor to be a 100Ω h.t. surge limiter and on retesting for an h.t. short we found that there was only a few hundred ohms from the h.t. rail to chassis and that this vanished when the c.r.t. base connector was removed to ensure that our ohmmeter current was not passing through the BY100.

The first suspect where heater-cathode insulation is concerned must always be the boost rectifier, and on removing the e.h.t. cover we found that the glass envelope of the PY81 was cracked and the heater burnt out. This would normally result in an open-circuit heater chain but in this extremely rare instance

the end of the broken heater leading to the next valve was internally contacting the anode, with the result that the heater circuit was applied across the h.t. rail and chassis.

This explained all the symptoms, the valves taking a long time to warm up, the surge limiter overheating and the speaker hum due to the smoothing electrolytics being unable to provide the normal smoothing action because of the excessive current demand. On replacing the surge limiter and PY81, the reception was back to normal with the BY100 giving full voltage output despite its gross overload. All in all an unusual fault caused by a rare rectifier defect, but once again proving how important it is to look for all visual evidence. This time the cracked envelope of the PY81 was the give-away.

Testing Power Transistors

IN most cases testing suspect transistors by measuring their forward/reverse junction resistance ratios gives a good workshop guide to their capability. These tests of course give no indication of current gain but if the junction ratios are at least 25:1 the transistors can be regarded as at least operational. The only real snag with this test is that the internal ohmmeter battery voltage must not exceed the reverse transistor voltage rating—sometimes the case with multirange instruments on a high-resistance range.

With the increasing use in TV sets of high-power transistors which have very low forward resistance and therefore comparatively low reverse resistance however it is far better to use a method which more clearly indicates their actual operation; that is, application of forward base-emitter bias to instigate

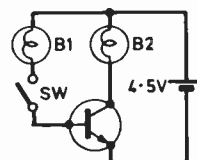

Fig. 1: Circuit of the power transistor tester suggested in the *BRC Bulletin*. Reverse the battery polarity to test pnp transistors.

collector current. In a recent *BRC Bulletin* G. L. Ashman suggested a very simple method which merits wider mention to aid service engineers. A single-pole switch, 4.5V battery and two 3.5V, 0.3A bulbs in holders are all that are required and when connected as shown in Fig. 1 will indicate the following:

Switch open: B2 should not light as there is no forward bias applied. If it does light there is a collector-emitter short-circuit.

Switch closed: Both bulbs should light, forward bias being applied through B1. If only B1 lights there is a base-emitter short-circuit. If neither bulb lights the transistor is open-circuit.

The arrangement as shown in Fig. 1 tests npn transistors but by simply reversing the battery polarity the hook-up will test pnp transistors, and if it is constructed with a reversing switch in a small box it will prove of value in the service workshop. The tester would probably be best used with fairly long test-leads terminating in miniature crocodile clips so that these power transistors can be tested in situ on unsoldering the base and emitter connections.

TO BE CONTINUED



SHADOWMASK TUBE

faults

PERHAPS the most disastrous thing that could happen to a colour receiver owner would be for a service engineer to turn to him and say "Sorry, you need a new tube!" It brings back memories of the days when the monochrome c.r.t. was also a highly priced component and the business of television rental companies leaped forward. Today even the largest 23in. twin-panel monochrome c.r.t. should cost no more than £14 and for the majority of receivers c.r.t. replacement can be made for about £8.

The fright of tube replacement is now transferred to the shadowmask tube in the colour receiver where £70 would be needed by the customer. The wise owner might take out tube insurance. Other owners turn to rental and this trend is assisted by the scare stories that have appeared from time to time in the national press giving the impression that a colour receiver is three times more likely to go wrong, is three times more expensive to repair, needs a service engineer about three times more capable to make efficient repairs (if you can find one who knows anything about colour) and needs an expert to set the receiver up in the home. The result is that the majority of people who have a colour receiver have it on rental (and with the government requirements on deposit the renter has a great proportion of his capital outlay met for him).

The author has been working with colour television since before PAL was devised and in the total period of NTSC and PAL experience has had to replace between 20 and 30 shadowmask tubes. The majority of these tube replacements were before circuitry rigidly controlling the e.h.t. was in use and when the stability of receivers and monitors was very poor. These things have changed and during the past three years it has only been necessary to replace perhaps one tube a year. Undoubtedly however ageing tubes will begin to occur more frequently in PAL receivers as the number of sets increases and the service engineer will then begin to find tube replacement a fairly commonplace thing.

Basic Faults

Replacing a shadowmask tube is not the kind of thing to be undertaken lightly. Apart from the costs involved it is a long-winded operation and inevitably takes longer than it should because of its unusualness. It is therefore very important first to ensure that the replacement is actually necessary. It might naturally be assumed that the tube has faults peculiar to its

design. In general this is not true although there are some exceptions which will be noted later. The common monochrome c.r.t. faults reappear in the shadowmask tube but as there are three electron gun assemblies in the tube a fault may affect only one gun or one colour in the display. The common tube faults are those of low emission, changes in cut-off voltages, grid-cathode and cathode-heater shorts and leakages.

All faults on the tube should first be isolated to a particular gun. Failure or partial failure of one gun will indicate itself as an excess or lack of a particular colour in the display of a black-and-white picture. The same theory that applies to other colour servicing also applies at this end of the receiver—get the black-and-white picture correct first. A picture with a red, green or blue cast points to excessive beam current in that gun. A low beam current would give casts of yellow, cyan or magenta.

Is the Tube Faulty?

When such a condition appears it is of course more than likely that there is no fault in the tube at all and that only the set-up needs adjustment or that an imbalance fault has developed in the drive circuits to the tube. The normal grey-scale line-up adjustments

Table 1: Approximate shadowmask tube potentials for correct operation—colour bars being received and controls set for normal operation.

Voltage	Colour-difference drive	RGB drive
Grid d.c.	60—110V	0V
Grid signal	100—180V peak-peak (R—Y, G—Y, B—Y drive signals)	50V peak-peak (flyback blanking waveforms)
Cathode d.c.	190—260V	130—160V
Cathode signal	70—100V peak-peak (luminance drive)	60V peak-peak (excluding sync excursions; RGB drive signals, all negative-going)

Notes: (1) RGB drive is approximately 30% more efficient than colour-difference drive.

(2) With colour-difference drive the green and blue cathode signals are generally lower than red.

should be attempted and usually the fault condition will be corrected. If the fault cannot be cleared in this way the two guns which are giving a normal display should be cut-off leaving the abnormal display in the faulty chain for examination. The chain may be faulty for a number of reasons, a faulty tube being the least likely. Other reasons are incorrect biasing and incorrect drives, i.e. incorrect cathode-grid d.c. voltages and cathode-grid signal voltages.

Table 1 shows the approximate d.c. and a.c. signal voltages which might be expected on a shadowmask tube. Two sets of figures are shown, one set for a colour-difference driven receiver (i.e. R-Y, G-Y and B-Y signals at the grids and luminance Y at the cathodes) and the other set for RGB driven receivers (i.e. R, G and B signals at the separate cathodes).

It is emphasised that these figures are approximate and that different receivers may use slightly different potential differences between them. The readings will also vary with the drive and background and contrast and brightness settings. Some tolerance should therefore be made in assessing this information and any doubts should be cleared by reference to the manufacturer's service manual.

If a serious error exists in any of the drive conditions normal servicing techniques must be applied to the faulty chain to locate the fault. If the drive conditions appear normal, indicating a tube fault, the picture produced by the faulty gun can be examined.

Low Emission

This is the most common fault on older tubes and is associated with normal deterioration of the gun cathode surface. It gives the same symptoms as low emission in a monochrome c.r.t.; lost resolution in picture highlights; plastic effects with the brightness/contrast increased; dull picture. The only difference of course is that these effects will be in a primary colour rather than in black-and-white. Another useful indication of low emission is excessive time in tube warm-up in one gun only producing a gradually changing cast on a monochrome picture. It should be noted however that excessive time in this case should be taken as longer than 20 minutes or so—most shadowmask tubes appear to exhibit some differences in warm-up times between guns and this is not usually indicative of a fault condition.

Low emission in one gun can usually be corrected by altering the drive to that gun or if the emission has fallen rather greatly by changing the preset drive links on the c.r.t. cathodes (of a colour-difference driven receiver). Severe loss of emission (when limiting takes place) can only be corrected by tube replacement. Heater boosters have no place here because a common heater is used for all three guns.

Cut-off voltage changes (normally due to the mechanical movement of one electrode with respect to another) sometimes occur and give similar effects to low emission. It is very rare for these changes to be significant enough not to allow setting the gun cut-offs within the normal control ranges.

Interelectrode Leaks and Shorts

Grid-cathode leakage on a tube usually gives obvious symptoms. The result is to reduce the grid bias so that the tube conducts or tries to conduct

when the brilliance is reduced. On pictures the result is an increasing predominance of the faulty gun's colour output as the brilliance control is reduced. In the extreme case of a grid-cathode short-circuit the gun concerned never extinguishes leaving a raster of that colour even when the brilliance control is at minimum. Heater-cathode leakages and shorts are very rare on a shadowmask tube because of its construction. If they do occur hum will tend to appear on one colour only.

Miscellaneous Tube Faults

Insufficient picture contrast on all three guns or other signs of general picture deterioration should always result in a check on the 6.3V heater voltage, the h.t. voltage, the e.h.t. voltage, the second anode (focus) voltage and the boost rail supplying the first anode voltages.

An open-circuit heater is of course possible with any type of tube. Replacement is usually the only cure. *Warning:* Attempts to clear interelectrode shorts or heater open-circuits using the 25kV e.h.t. in a colour receiver will result in one or more of the following: (1) Encashing of life insurances by the widow of the service engineer. (2) Failure of the e.h.t. multiplier. (3) Failure of the line output transformer. All three are expensive.

Misaligned electron guns and phosphor defects can occur in shadowmask tubes. Neither of these defects should ever be seen by a service engineer since such tubes should not reach the receiver at all. However, one such similar type of fault that has been found on a new receiver was presumed to be due to the tolerances of manufacture. The receiver in question had been delivered to the customer without complete set-up being undertaken in the shop because of the delays that the customer had already experienced. The only checks made were that the receiver gave pictures and sound on u.h.f. and v.h.f. The service engineer making the delivery was familiar with the receiver model and it was therefore a considerable surprise when he returned to the shop with the receiver some hours later saying that he could not converge it! The service manager then spent some hours attempting to converge the receiver and he too admitted defeat—the symptoms being relatively good static convergence but quite intolerable dynamic convergence. Most of the errors were in a horizontal direction, on blue. After replacing and testing most of the convergence control circuitry the author was asked to assist.

The fault condition was finally cured by replacing the convergence coil unit with one from another receiver. It was naturally assumed that the unit was faulty until it was put in the second receiver. This receiver could be converged! The only possible explanation is that the tolerances of the tube and the original scan unit were both at their limits and that the two together added up to cause the fault. Used with a unit with either a mean tolerance or one lying in the opposite sense everything was OK.

Another shadowmask tube fault which has been known has been buckling of the metal shadowmask itself. The fault developed about six months after the set was installed and resulted in extremely poor purity. The cause was not confirmed but the replacement tube is still operating correctly some three years later. Recent talks have suggested that this kind of tube fault may be caused by either an excessive field

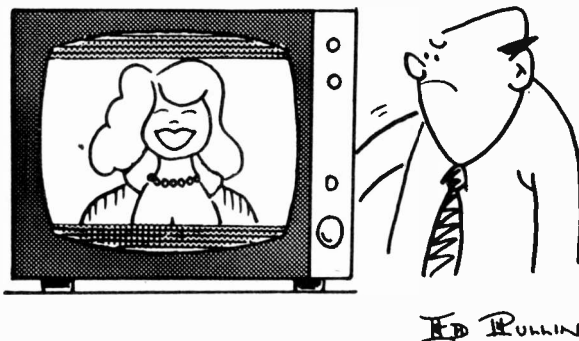
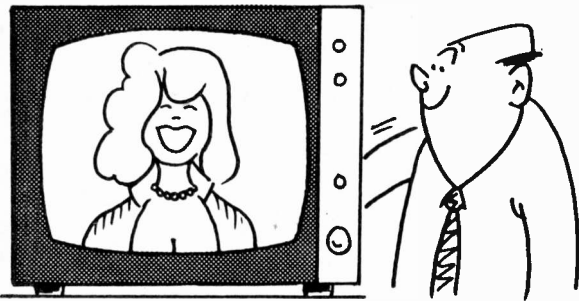

from an auto-degaussing circuit or an inbuilt weakness in the tube's mask which then warps under the influence of the degaussing field.

Shadowmask Tube Replacement

In all colour receivers replacement of the tube involves removal of the chassis. This varies from bolt fixing to two self-tapping screws and a sliding cage arrangement. The tuner unit(s) and some brackets must also be removed on some receivers to give enough access room to withdraw the tube. Disconnections at this stage are the e.h.t. lead to the final anode cavity, the scan and convergence leads from the chassis, speaker leads, tuner leads (even if this is to be removed with the chassis), tube base plate, leads to any components left fixed in the cabinet (the power supply in some receivers) and the connections to the degaussing coil. All connecting leads or positions should be noted or marked before or as they are removed. Usually these connections can be removed with the chassis partially withdrawn from the cabinet. The chassis can then be fully withdrawn.

The cluster of tube neck components is next to be removed, the position and orientation of each being noted before removal. The exact method of attachment of these components differs between manufacturers and normally setmakers use both Mullard and Plessey components the possible mixtures of them resulting in seven different variations. The components are: lateral blue shift, purity rings, convergence unit and scan yoke (from the base end to the bowl of the tube).

The only impediment to removing the tube remaining is the magnetic screen carrying the degaussing coil. This is usually held to the tube retaining bolts by four extended springs—one from each corner. Note which holes on the shield are being used for spring retention before removal. On occasion the

shield is held by four separate corner nuts which screw down over the tube retaining nuts. After removal of either the springs or the nuts the shield will be completely free and can be slid down over the tube neck.

The receiver should now be laid on a protective surface of blankets or a similar padded surface. A separate rolled blanket should be placed toward the top of the cabinet to prevent the tube from resting on the surface and thereby taking the weight of the cabinet on its face. The four retaining bolts or nuts (one in each corner of the tube) can then be removed. They should be loosened with a socket spanner to reduce the possibility of a slipping open-ended spanner knocking against the flare of the tube. Note that there may be a static discharge lead with a tab washer fitted to one of the mounting bolts or studs.

Removal of the tube itself is now a matter of lifting it from the cabinet. All the normal c.r.t. carrying precautions should be observed but it is most strongly urged that additional precautions be taken, namely that thick, non-slip gloves are worn and also goggles. These precautions are advised because of the weight of the tube—about 40lb.—and its design which does not favour lifting. For these reasons too the lifting should take place with the receiver laid on the floor in the way described above. Stand with your feet fairly wide apart and with a straight back lift out the tube and put it down as soon as possible on either a padded surface or into a tube carrier. The new tube is then lifted into the receiver in the same way. At no time should the tube be carried by the neck and the path between the receiver and the point of depositing the tube should be left completely clear of obstacles. Allow no one near you when carrying the tube. An imploding shadowmask tube is much more dangerous than an imploding monochrome one.

The new tube is fitted in the same position and orientation as the old one and generally this is with the blue gun upwards. The side of the tube with the blue gun is indicated by the e.h.t. cavity socket. On the BRC 3000 chassis the blue gun is mounted downwards—the e.h.t. cavity socket again indicating this. On receiver presentations with front masks adjustment for tube position is normally provided by secondary nuts on the tube mounting studs. These are adjusted by first spinning down the nuts and then after allowing the tube to rest on the mask retracting the nuts so that they just take the weight of the tube off the mask.

After the tube has been tightened down and the magnetic shield and tube neck cluster replaced the various interconnections should be remade with the chassis again partially inserted into the cabinet (the so-called service position). All the connections should be rechecked before power is applied.

The e.h.t. voltage should be checked in the manner advised by the particular manufacturer (e.g. by measuring focus current) and the "set e.h.t." control adjusted as necessary. The normal line-up procedure is then adopted of checking and setting if neces-

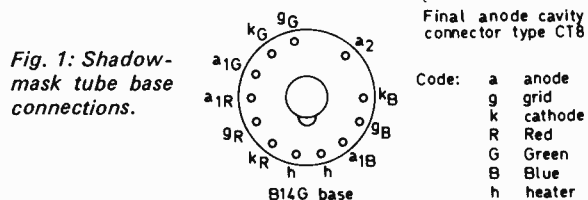

Table 2: Comparable shadowmask tube types.

19in.	A49-120X,* A49-191X, A49-11X, CTA1951†, A49-200X
22in.	A56-120X,* A55-141X, A55-14X, CTA2250†
25in.	A63-120X,* A63-11X, A63-16X, CTA2550†, A63-17X, A63-13X, A63-200X

* Current Mullard types for new receivers.

† Mazda types.

Pro-Electron type numbers used on Mullard and RCA tubes.

sary static convergence, picture squaring, purity, height, width (if fitted), vertical and horizontal shift, grey-scale tracking and dynamic convergence. If large errors are seen to exist in any of these adjustments it is advisable to repeat them all because some are to a certain extent interdependent—e.g. static convergence and purity. It is normal on a shadowmask tube to have to provide maximum drive to the red gun. If the range on a colour-difference driven receiver is insufficient on green however the preset links in the red/green cathode feeds can be changed over.

Tube Types

The shadowmask tubes used in the original PAL receivers were manufactured by RCA. Production of Mullard and Mazda types followed and a later development was that of "squared" tubes for push-through presentation. There are therefore a number of replacement types and these are noted in Table 2. The usual base connections to shadowmask tubes are shown in Fig. 1. Any spark gaps on the tube base socket that have obvious signs of burning should be replaced at the same time as the tube. They may well arc at a lower potential than they were designed for if a carbon track has been laid, or they may have burnt back and not arc until far too high a potential is reached.

Disposal of Old Tubes

There are now firms willing to undertake the task of regunning or rebuilding shadowmask tubes so this is one method of disposal. Another possibility is to use the faulty tube in a test jig for receiver chassis. A large servicing organisation takes relatively little time to acquire a faulty tube, convergence unit and scan coils and these can be built into a small cabinet. Alternatively the normally carried spares of these items can be used until they are required for a servicing job. The jig enables the service engineer who cannot correct a receiver fault in the home the reasonably easy task of removing the chassis from the receiver and bringing it *only* to the workshop for repair. For those of us who have had to carry colour receivers up and down flights of stairs and through narrow doorways this procedure comes as a relief. If a yoke fault is suspected on the receiver (either scan or convergence) these items can be returned with the chassis to the workshop.

The test jig cannot of course use a faulty tube if the fault is such as to give complete tube failure. It is ideal however if only one gun has very low emission. Even though the tube is useless for viewing it is simple enough to reconnect drives to check a channel not correctly displayed. ■

NEXT MONTH IN

TELEVISION

BASIC TV CIRCUITS FOR THE CONSTRUCTOR

Next month we start a new series on basic "building block" circuits for the constructor. A new circuit will be presented each month and the complete series will enable a high-quality monochrome TV receiver to be constructed. As the 405- and 625-line circuits are separate either a dual- or single-standard set can be built up. We start off with a three-transistor i.f. strip for the 405-line standard.

THE FAM SYSTEM

FAM stands for frequency-amplitude modulation and the FAM system is a fully developed colour TV system that was once a contender in the European colour TV stakes. The FAM system is not compatible but has considerable advantages for certain applications, in particular as a technique for adding colour to comparatively low-cost videotape systems. It could also become the standard system for colour CCTV. A full account of the system and its operation will be given.

ADDING AFC

Tuning on u.h.f. can drift for a number of reasons. The best answer is to add a.f.c. to your receiver. A practical add-on circuit will be presented for controlling a varicap diode in the u.h.f. oscillator tuned circuit, with detailed instructions on setting up.

TEST REPORT—1

Next month we start a series of Test Reports on items of interest to service engineers in particular, starting off with the Antex desoldering iron.

PLUS ALL THE REGULAR FEATURES

ORDER YOUR COPY ON THE FORM BELOW

TO.....
(Name of Newsagent)

Please reserve/deliver the JUNE issue of TELEVISION (20p), on sale MAY 22, and continue every month until further notice.

NAME.....

ADDRESS.....

Workshop

HINTS

by VIVIAN CAPEL

OUR workshop hints this month are devoted to what has proved for many years to be a troublesome component—the line output transformer. New materials and design concepts have made it more reliable than those used in earlier models, but the older ones still keep coming into the workshop and the engineer is expected to do what he can to keep them going.

Where there is a short-circuited turn in one of the transformer windings—a common fault—there is little that can be done other than to replace the transformer. Sometimes it is possible to obtain a transformer insert which consists of the windings on their bobbin. The old transformer can then be dismantled, the old bobbin removed and the replacement fitted. When reassembling take care to refit pads of foam or other material where they appeared in the original otherwise line whistle may be excessive. Make sure, too, that the core sections are securely clamped together or there will be a loss of magnetic efficiency and the line scan may be insufficient to fill the screen.

Usually the lead-out wires from the bobbin are coloured the same as the originals but as this is not always the case care must be taken to ensure that the correct connections are made. Before dismantling the old bobbin check each wire with the new one and note any differences. A rough sketch can then be made showing the colours and the tags to which the wires should be connected. Alternatively the old wires can be cut with a short section left on the tag so that the colour can be identified. Although this is quicker than making a sketch the snag is that the sleeving will drop off once the wire is cut, leaving an unidentifiable length of tinned copper wire. To prevent this the end of the wire should be bent back to retain its insulation when it is cut.

It will of course be necessary to identify the various leads connected from the set to the transformer tags. A sketch is the best method here as the wires may not be long enough for a portion to be cut off. Small wire-ended components are also likely to be connected to the transformer and need to be identified. Watch out for similar coloured wires going to different tags: these are not always noticed when making the sketch and disconnecting and it can be baffling to find two or even more wires of the same colour when connecting up the new transformer.

Corona Discharge

Most of the troubles with line output transformers arise from the high voltages associated with them.

These often lead to brushing or corona discharge. The effect takes the form of one or two elongated white splashes on each scanning line. As these are in the same place on each line the overall effect is a jagged white vertical streak down the picture (see Fig. 1). Locating the precise point where the discharge is taking place is not always easy. A careful examination of the transformer may reveal points or spikes on soldered connections, the joints on wire-ended rectifiers being common offenders. If spikes are found the connections should be resoldered to form a smooth surface. Pulse capacitors which are soldered across sections of the windings sometimes cause corona from their lead-out wires or they may even be discharging internally.

Tracing Corona

There are two ways in which corona can be traced, by visual or aural inspection. If the workshop is darkened or probably more practically the chassis covered with a blanket so that light is to a great extent excluded but the line output stage components can still be observed it may be possible to see the discharge. It takes the form of a faint blue or purple glow usually bridging a point of high to one of low potential. Not only the line output transformer but other associated components such as width and linearity coils and even the scanning coils can produce brushing (although the latter are not so common as a source). Hence these too should be scrutinised for the discharge glow.

If the trouble cannot be found by observation it may be possible to hear it. Corona generates a high-pitched noise like a hiss at the line frequency. This is very faint and also directional and so fairly easy to localise by close listening. Placing the ear close to the line output stage is definitely not recommended however: the use of a listening device is convenient and far less risky. An ideal device is a doctor's stethoscope. A cheap model could be obtained from a medical supplier or alternatively toy sets can be obtained that are quite adequate for the purpose although somewhat small. As an emergency measure if no stethoscope is to hand a length of wide-bore sleeving or some other tubing can be used. One end is held to the ear and the other used as a probe to explore the area where discharge may be taking place. This leaves the other ear free and if the workshop is noisy detection of the faint brushing sounds can be rather difficult. This is a problem we must leave to the reader's ingenuity to solve.

Dealing with Corona

It is often found that brushing is coming from the e.h.t. overwinding. The voltage here is obviously much higher than at other parts of the transformer and as the overwinding is wound on the outside of the other windings it is nearer external metalwork. The outer parts of most—if not all—overwindings are usually covered with pitch or wax and sometimes cracks appear in this covering (see Fig. 2) exposing the windings inside and leading to corona discharge. The remedy here is usually simple, just run the hot soldering iron along the cracks to allow the material to melt and fill the cracks. With pitch a whole section of the covering may have become detached: the free pieces can be melted and run into the gap. Melting

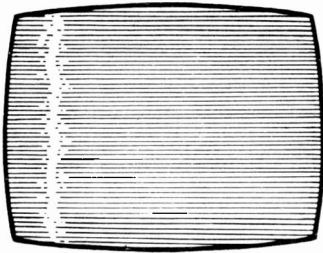

Fig. 1: Corona discharge on a blank raster appears as a ragged vertical white streak.

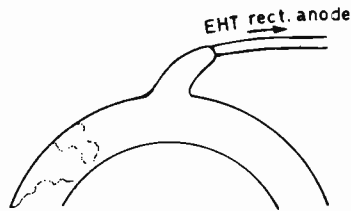

Fig. 2: Cracks in the pitch covering of an e.h.t. overwinding can cause corona.

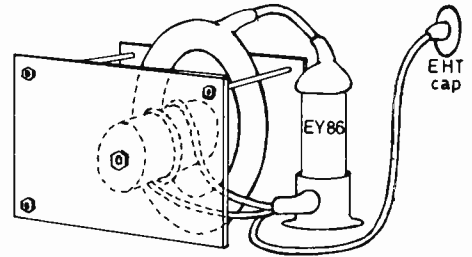

Fig. 3: Typical line output transformer showing the e.h.t. rectifier heater winding.

pitch with a soldering iron makes rather a mess of the iron unfortunately, so it is wise to clean the pitch off as soon as possible after the job has been done to prevent it baking on. Wax is not as troublesome.

Another source of trouble with some models is the leadout wire from the overwinding to the e.h.t. rectifier anode. The fine wire of the winding is often anchored to a terminal which is embedded in the pitch and a thicker wire soldered to it for connection to the rectifier. If this terminal becomes loose in its setting the fine overwinding wire breaks but because of the close proximity arcing occurs and the supply is maintained by this means. The result is severe interference on the picture, similar but much worse than brushing. Gently prodding the rectifier wire with an insulated tool where it leaves the overwinding while observing the effect on the picture should determine whether this is in fact the cause of the trouble. If it is the covering should be carefully broken away to expose the terminal and the fine wire then resoldered to it. The terminal should be set in the covering material by melting the material around the terminal, the rectifier lead attached and finally the whole lot covered over.

Sometimes brushing or even flashovers occur because nearby components, screening or other objects are too near. Repositioning or bending such screens may help; alternatively glue strips of polythene insulation along the affected area. Generally however a jump over a fair-sized gap needs a sharp point to initiate it so as mentioned before check the contours of all terminals or metalwork bearing pulse voltages.

Another possibility is that the line output valve is being driven too hard so that the pulse voltages are higher than they should be. If a service manual is handy check with a meter the boost voltage given. If it is high steps must be taken to reduce the level at which the stage is operating. Some sets incorporate a drive control in the form of a trimmer in the line output valve grid circuit while others use a preset skeleton resistor to vary a boost-rail derived positive voltage which backs off the negative bias applied from the e.h.t. stabilisation circuit to the grid. These controls may be misadjusted and should be set according to the instructions in the manual.

In some older sets rectifiers of the EY51 type were mounted on perspex transformer tops (for example some Ekco models) or in bakelite coffin-like boxes (for example certain Ferguson sets). There are few of these around now, but occasionally one may find its way on to the bench. The plastic supports or containers were very prone to start tracking across the surface. This led to cracks in the material and these

further guided the tracking which soon became conductive. Eventually the whole thing became a mass of conductive paths and burnt material. Nothing can be done with the plastic and while at one time replacements were available it is doubtful whether they are now—or if they are whether changing them would be economic in view of the age of the receiver. The only thing to do if the set must be resuscitated for a while longer is to break away the material entirely, leaving only the solder studs for the rectifier. The rectifier is thus air-spaced from the rest of the transformer and supported by the connecting wires. It may be necessary to reinforce these with thicker wire but in most cases the transformer wires are strong enough to support the valve.

EHT Rectifier Heater Winding

A common fault with many transformers is flash-over from the rectifier heater winding to the core or other sections of the transformer. The winding is insulated to stand the full e.h.t. voltage but because of heat and ageing the insulation cracks and flashovers occur. These sometimes occur quite infrequently—perhaps once in every several minutes—and the effect on the picture is then a momentary jump which may be scarcely noticeable. The main effect is a sharp crack which most customers find very disconcerting! If the insulation damage is in a more vulnerable position the flashover may be continuous, giving a “frying” sound accompanied by signs of burning. Usually there is no difficulty in spotting the source of the trouble.

Usually it is a comparatively easy matter to replace the defective winding—much easier in fact than attempting to repair or reinsulate the old one. The winding consists of anything from two-six turns of e.h.t. cable wound loosely around the transformer core or primary winding (see Fig. 3). The main consideration is to count the turns on the old winding and make sure that the new one has the same number. If the old windings were tightly wound and retained by being tied, do the same for the replacement.

If e.h.t. cable is not to hand the centre conductor from a length of coaxial cable can be used. The insulation is thick and of similar type to that of e.h.t. cable. Just strip off the outer plastic cover and slip off the braiding. When connecting the ends of the winding to the rectifier valveholder be careful to connect to the correct end of any series resistor which may be included to reduce the current. If the same pins to which the old winding was connected are used, there should be no problem.

FEATURE TO BE CONTINUED

DX-TV

CHARLES RAFAREL

THERE seems at last to have been a marginal improvement in SpE reception during the past month. Whereas there were days in January when in spite of continued vigilance there was no reception, in February there was some activity every day. This at least is a change for the better. To put it another way, instead of several "nil" days this time I have had some days with unidentified signals in the form of short bursts of programme which try as I would could not in any way be identified.

This of course is always a problem. Recently I have been fairly lucky in spotting written captions to confirm the origin of signals but during the past month SpE has been very perverse in this respect. Just when one wanted a good image the signal vanished, and even with patience for three days I could not identify anything at all! I suppose there is no answer to this problem except to increase our efforts: however I am getting "square eyes" already and there is a real risk that the c.r.t. will require replacement before the 1971 season really gets going!

Well that is the résumé of the past month's SpE activity here. There are one or two points that emerge, first SpE was for me exclusively towards the East, secondly very short skip to Belgium was again noted with signals at great strength for short periods. Now to the SpE log for 1-28/2/71:

- 1/2/71 USSR R1.
- 2/2/71 W. Germany E2, Belgium E2 (short skip).
- 3/2/71 USSR R1.
- 4/2/71 Poland R1.
- 5/2/71 Austria E2a.
- 6/2/71 USSR R1.
- 7/2/71 Czechoslovakia R1, USSR R1, Unidentified R1.
- 8/2/71 Poland R1.
- 9/2/71 USSR R1, Czechoslovakia R1.
- 10/2/71 Czechoslovakia R1.
- 11/2/71 Czechoslovakia R1.
- 12/2/71 Czechoslovakia R1, W. Germany E2, Belgium E2 (short skip).
- 13/2/71 Austria E2a, W. Germany E2.
- 14/2/71 USSR R1, W. Germany E2.
- 15/2/71 Austria E2a.
- 16/2/71 USSR R1.
- 17/2/71 Unidentified R1.
- 18/2/71 Unidentified R1.
- 19/2/71 Unidentified R1.
- 20/2/71 USSR R1, Austria E2a, W. Germany E2.
- 21/2/71 USSR R1.
- 22/2/71 Czechoslovakia R1, Austria E2a.
- 23/2/71 Czechoslovakia R1.
- 24/2/71 Czechoslovakia R1, W. Germany E2.
- 25/2/71 Czechoslovakia R1, Austria E2a.

- 26/2/71 Czechoslovakia R1, Poland R1.
- 27/2/71 USSR R1, Unidentified R1, Austria E2a, W. Germany E2, Sweden E2.
- 28/2/71 Czechoslovakia R1, USSR R1.

The Trop's were none too good although during the better ways of the 4th, 7th and 26th the Belgian and French (u.h.f. as well) stations were around. The best day was the 26th—in fog—but it did not last very long.

Italy: Thanks to Roger Bunney and his Italian DX contact we now give the latest list of R.A.I. test card numbers. This number appears in the top corner circle of the card. It is unfortunately rather small but when it can be deciphered it does indicate the exact location of the transmitter (with the exception that for 15 minutes before the start of programmes "S8" appears networked from Rome as noted in our last issue). Otherwise the identification numbers are as follows:

- | | |
|------------------------------|-----------------------------|
| 1 Turin ch. G. | 17 Mt. Luco ch. 23 u.h.f. |
| 2 Milan ch. C. | 18 Mt. Scuro ch. G. |
| 3 Mt. Penice ch. B. | 19 — — — — — |
| 4 Mt. Venda ch. D. | 20 Mt. Beigua ch. 32 u.h.f. |
| 5 Portofino ch. H. | 21 Mt. Soro ch. E. |
| 6 Mt. Serra ch. D. | 22 Mt. Lauro ch. F. |
| 7 Mt. Peglia ch. H. | 23 Mt. Cammarata ch. A. |
| 8 Rome ch. G. | 24 Mt. Pelligrino ch. H. |
| 9 Trieste ch. G. | 25 Udine ch. F. |
| 10 Mt. Favone ch. H. | 26 Mt. Argentario ch. E. |
| 11 Mt. Faito ch. B. | 27 Mt. Limbaro ch. H. |
| 12 Mt. Vergine ch. D. | 28 — — — — — |
| 13 Mt. Sambuco ch. H. | 29 Mt. Serpeddi ch. G. |
| 14 Mt. Caccia ch. A. | 30 Pescara ch. F. |
| 15 Mt. Martini Franca ch. D. | 31 Mt. Nerone ch. A. |
| 16 Roseto ch. F. | 32 Mt. Gonero ch. E. |

Channels A and B in Band I are the ones for SpE reception but as I know from my own experience ch.C in Band II is also possible by SpE. The others are in Band III or u.h.f. but with our Trop distances having increased significantly in the past year I feel anything is possible.

Albania: From the same source we learn that DXers in South Eastern Italy have been picking up ch.R5 Band III from Albania across the Adriatic. The only officially listed Albanian station is Tirana R2 on low power but we reported some time ago that a new TV centre was being built there and that the service looked as if it was going to be developed. It seems that this has now started and we must hope that Tirana increases its power and that perhaps other Band I stations will come into service.

Yugoslavia: Our same informant tells us that J.R.T. Yugoslavia are transmitting programmes in Italian for the benefit of Italian viewers. We do not know yet from which Yugoslavian stations but I would suggest that Labistica ch.E4, a high-power coastal station in Band I, is a likely one. It would only have a relatively short distance over the Adriatic to travel. If this is correct it means we shall have to be very careful with loggings on ch.E4/1B as the Italian language could in fact be of Yugoslav origin.

The postal strike has unfortunately deprived us this month of some of our sources of news, logs, etc.

I have had my own personal problems over this in getting these two latest articles to the Editor. I have had to inaugurate a private "pony express" and take them from Bournemouth to London by car. Not to worry, in spite of everything the mail gets through! When the strike is at last over we look forward to reading once again about your DX-TV successés. So do not forget, we are waiting to hear from you!

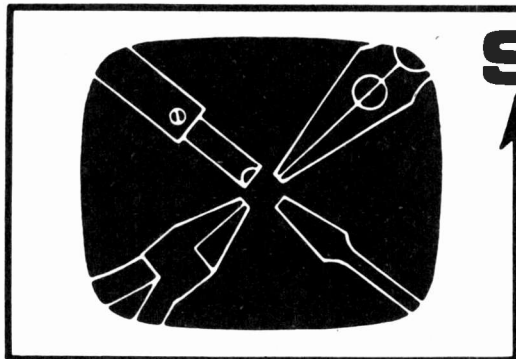

SERVICING television receivers

L. LAWRY-JOHN'S

PHILIPS STYLE 70 SERIES

THIS was a very popular and widely marketed series sold under the **Philips, Stella** and **Cossor** brand names. The original Philips model numbers are the 19TG170, 19TG171, 19TG173, 19TG177, 23TG170, 23TG171 and 23TG173. The Stella models are ST2049 and ST2133 and the Cossor ones CT1976 and CT2378. Further models were the 19TG175, 19TG176, 23TG175, 23TG176 and 19TG177, the ST2059 and ST2143 and some variations differing only in cabinet style and presentation.

The series is prone to several common faults some of which can be confusing when met for the first time but which present little difficulty once they are known. Perhaps the most awkward one is when the line output transformer fails as at the time of writing the supply situation is extremely difficult. However, we will deal with this and other line timebase troubles in detail under the "no picture" heading. Making an attempt at being logical we will commence at the mains input and work through from there.

Power Supply Circuits

The mains input is direct to the 1-5A fuse FS101 and thence to the on-off switch. A few models incorporate a clock and time switch but in most sets the live mains is taken from the switch to the dropper and the neutral to chassis in the normal way.

It is at the dropper that the first common fault occurs and it is most important to identify which parts of the dropper do which job. There are two main sections, one (R111, R112, R113) to which the live mains is taken and which is made up of three continuous parts and another (R114, R115, R116) which also carries the thermal cut-out spring (FS102). This latter section must not be looked upon as a dropper: it consists rather of the h.t. smoothing resistors (R115, R116) and surge limiter (R114) and they are of course at d.c. potential.

It is quite common for any one part to become open-circuit without warning or exterior cause. If pressed we would say that the 104 Ω section R112 is the most common part to fail. This of course stops the supply to the valve heaters. A replacement section of about 100 Ω will restore normal heater operation. R111 is the right-hand section of this dropper and is the a.c. supply resistor to the rectifier with a value of 20 Ω . If this section is open-circuit the heaters will continue to glow but the set will be dead as there will be no h.t.

The faulty section can be immediately identified by a simple neon test but check R111 first as failure here will prevent any supply getting to R114, R115 and

R116. Note the values of these resistors and don't depart very far from them when fitting replacements. Also note that failure of R116 will result in complete non-operation of the set but that there will still be fairly high h.t. at several points (as the HT1 supply will still be intact).

Drop Off Resistors

Those readers who are not familiar with Philips circuitry should pay particular attention to the presence (or absence!) of many current-carrying resistors which are designed to part company with their soldering tags in the event of their becoming overheated. These resistors are presented to the underside of the tags without the wires being wrapped round prior to soldering. This is another example of a thermal fuse and is an excellent means of avoiding the costly damage which can result when a resistor is left in a circuit carrying excessive current.

These drop off resistors will be found in the video and sound output h.t. supplies and also in the field output valve cathode circuit. Note that the field output cathode circuit and the video h.t. feed both use two resistors in parallel whilst the sound h.t. feed has only one. It is not uncommon for only one of a pair to drop off leading to some confusion when the fault is being rectified.

Say for example the PCL85 develops an internal short (and they do this often enough) causing the bias resistors (R443 and R444) to overheat. One resistor may fall off before the other and the set then be switched off before further overheating takes place. A repairer may correctly identify the fault as being a defective PCL85 but a new valve fitted without checking the bias resistors will produce a picture sadly compressed at the top. This is the result of too much bias caused by a single 560 Ω bias resistor. The other one would probably be found lying in the bottom of the cabinet.

The No Picture Condition

This is where most confusion will arise and where a logical fault-finding procedure must be employed. When we say "no picture" in this context we mean that there is no illumination upon the screen at all (no raster at any brilliance setting). The first step is to ensure that system switch is in the 405 position and to listen for the line timebase whistle. If it is present and sounds normal remove the top cover of the line output stage. Note whether the DY87 is lighting up. If it is it can be assumed that e.h.t. is likely to be in

Voltages measured on 405 lines with contrast control at maximum, no signal and 240V a.c. mains input, using a 100kΩ/volt meter. ECC82 grid voltages measured with 1MΩ resistor at probe tip.

For 625-line v.h.f. relay operation switch to 625, link switch tags 20 and 22 as shown and move the lead on switch tag 18 to B.

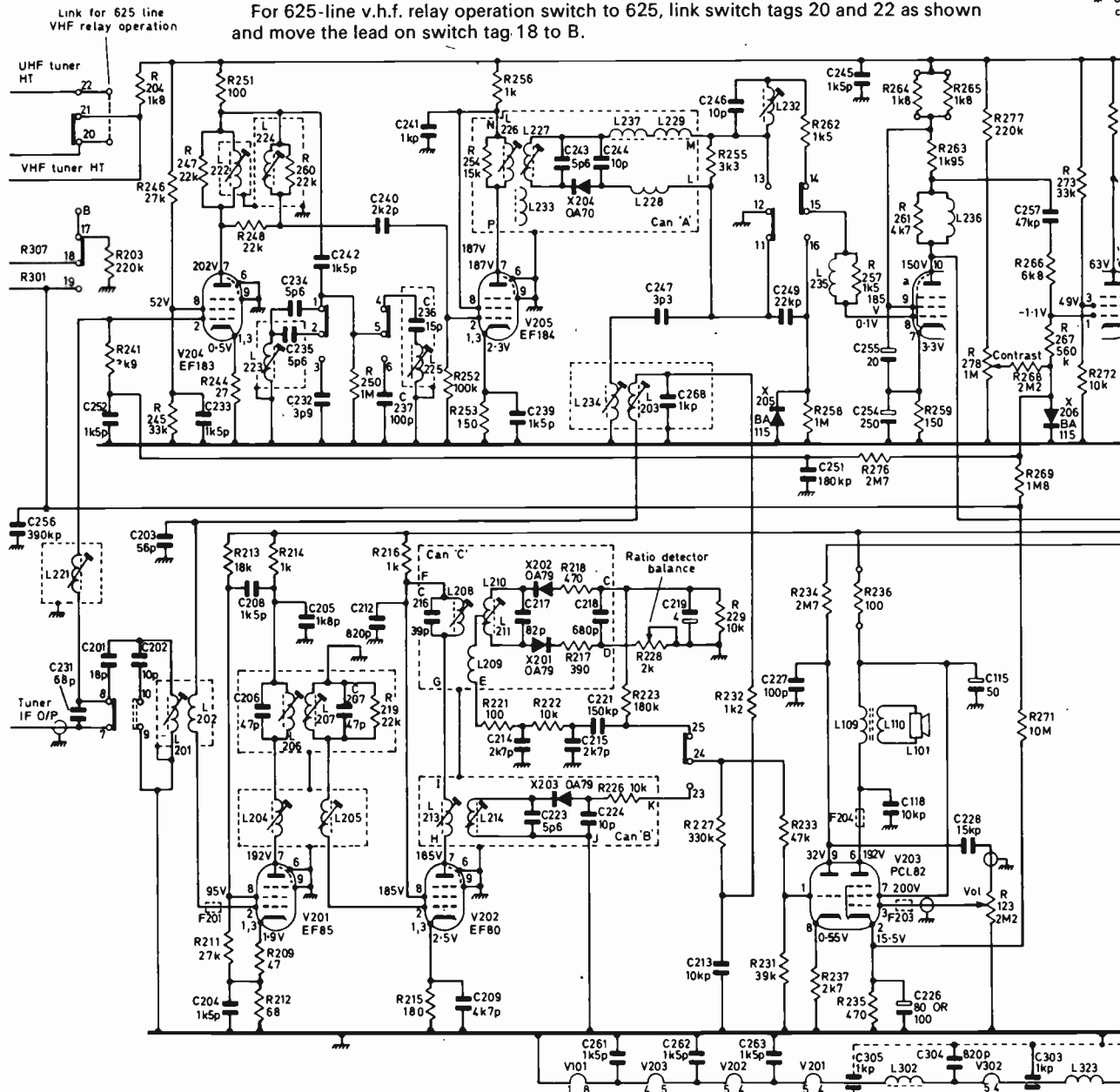

Fig. 1 : Circuit diagram of the Philips Style 70 chassis

order and that the fault is in the supply to the tube base socket.

It will be noted that an 0.05μF capacitor (C108) is wired across the bottom of this socket to decouple (to chassis) the boost line supply to pins 3 and 4. This capacitor is likely to be shorted. Cutting through the capacitor wire at the boost line end (right side) should restore almost normal operation with the picture a little lighter on the left side. A replacement 0.05μF (0.047μF) should be rated at 1kV.

In the unlikely event under these circumstances of the normal boost supply being present at pin 3 atten-

tion should be directed to pin 2 where the voltage should swing up to 125V as the brilliance control is advanced. If this voltage remains low or is absent check back to the brilliance control itself, its supply resistor R110 and the capacitors C105 and C420 (one of which may be shorted).

If it is found that the line whistle is normal but the DY87 is not glowing check this valve which may well have an open-circuit heater.

Now let's get down to the nasty bit (he said rolling up his sleeves and cracking his knuckles). If the line timebase whistle is not normal and can hardly (if at

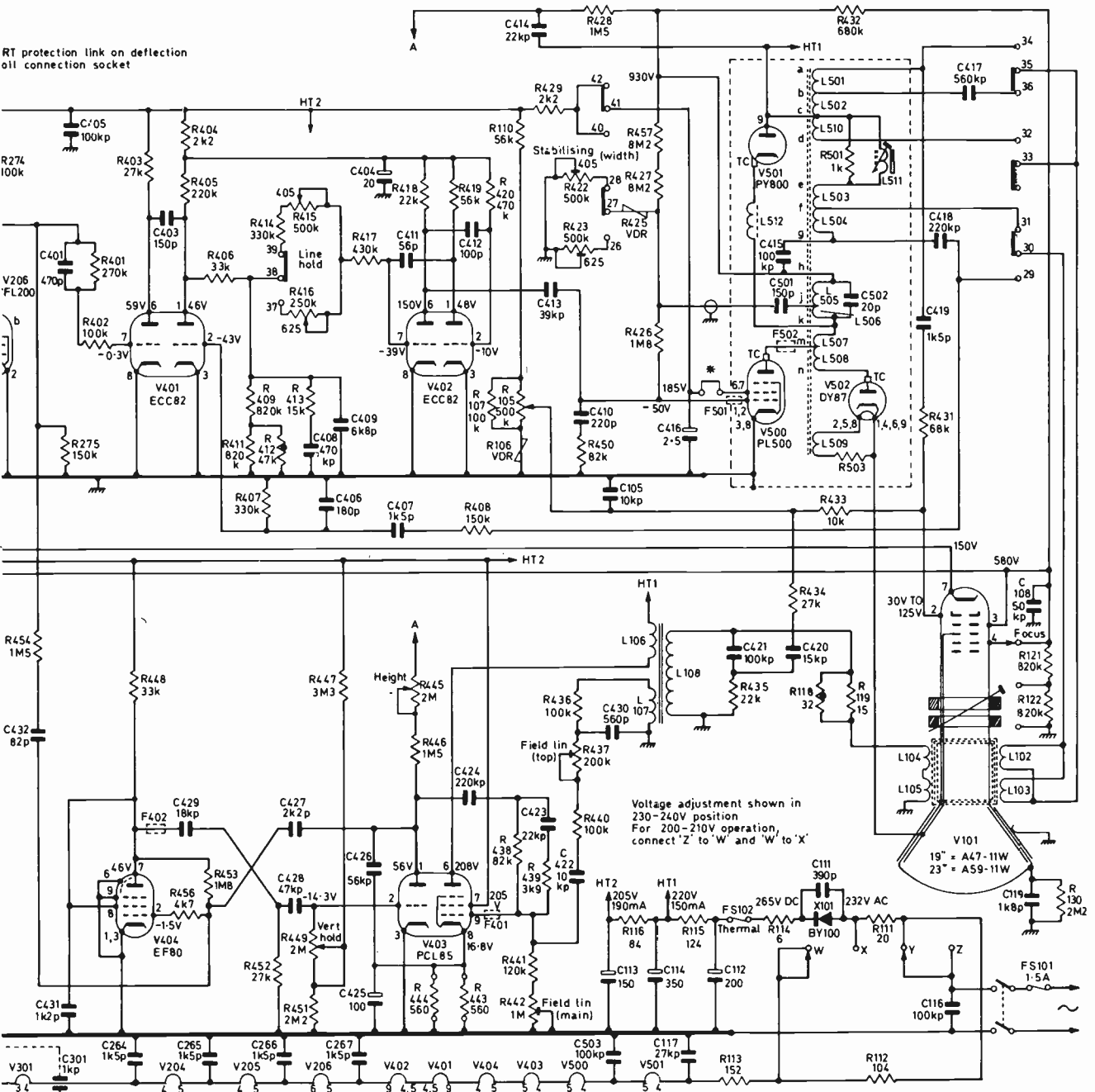

sis. System switching shown in 405-line position.

all) be heard check the h.t. voltage. If this is a little high you're in luck. If it is a little low you may not be. If the h.t. is well up—say over 220V at HT1—check the screen supply resistor to pin 6 of the PL500 (PL504) as it is likely that the PL500 is drawing no current. This resistor is R429, 2.2k Ω . It is not located near the PL500 but roughly half way up the right side panel.

If this is found to be open-circuit there will almost certainly be a cause. A replacement resistor may restore normal operation but the cause may remain and show up later with a repeat performance. The

cause is normally (notice how carefully we insert "normally") an intermittent short in the PL500 and it is recommended that a new PL504 is fitted at the same time as the resistor is replaced. The reader may well ask what about C416, couldn't this be a fault? The answer is yes it could, but we have yet to find this to be so.

If the supply to pin 6 of the PL500 is present and high change the PL500. If it's low (with the h.t. high) check the PY800. Fit a PY801 if you have the option.

If the h.t. is down and the line output stage is over-
 —continued on page 328

HI-FI TV SOUND UNIT

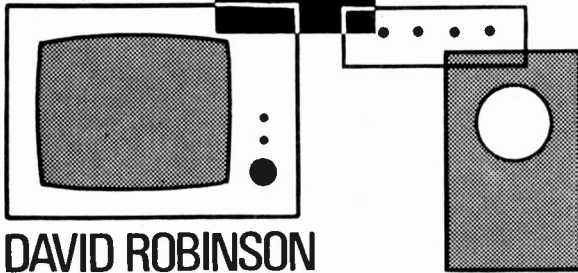

MUCH has been said about the gradual improvement in picture quality which has taken place since the beginning of the television service. It seems, however, that the trend in sound quality has been the opposite to that of the picture. It was not so long ago that TV sets were readily available in console style cabinets with 8in. or larger speakers fed from a reasonable audio stage. Nowadays, partly for economy reasons and partly because of the stereotyped slimline table-model cabinet styling, we seem to be stuck with 7 × 4in. speakers fed from mediocre audio amplifiers. Most sets have audio stages using a single triode-pentode valve with little or no negative feedback and a small speaker fed from a miniscule output trans-

former. This seems a great pity when the quality of the sound transmissions is as good as v.h.f. radio for most studio programmes and considering that the enjoyment of musical programmes—even *Top of the Pops*—is greatly increased by the provision of good-quality sound.

Tapping off the Sound

Many TV enthusiasts must have a good hi-fi audio amplifier available or be capable of building one, but tapping off an audio signal from the average TV set is not easy because of the inevitable live chassis plus the fact that the ratio detectors in many sets are not as well aligned as they might be.

The first idea that springs to mind is to build a completely independent sound receiver complete with u.h.f. tuner as part of the hi-fi system. Unfortunately this brings problems, too. The first is obviously cost since the unit would need to have a complete vision i.f. amplifier or the equivalent in order to provide the intercarrier signal, or alternatively if it was fed directly with the sound i.f. output of the tuner—that is at 33.5MHz—a.f.c. to the tuner would be imperative. Then there is the problem of having to operate two u.h.f. tuners each time when changing channels. Perhaps the most serious problem is that a separate aerial would have to be provided for the sound unit as in most cases it would not be possible to split the signal from the main aerial without seriously degrading the picture. Clearly this would be a hopelessly clumsy and expensive arrangement.

Solution Adopted

In view of these considerations I decided to adopt a compromise solution by tapping off a 6MHz inter-carrier signal from the main set and providing a high-quality amplifier-discriminator unit to feed the hi-fi amplifier. In this way the extra unit is made very economical and yet there are no problems with a live receiver chassis since the 6MHz outlet can be isolated with low-value capacitors in just the same way as a normal aerial connection. Also with this arrangement channel changing may be effected at the main set in the usual way and the set's own sound circuits are not affected and can thus be used again if desired at a later date.

Circuitry

The circuit of the amplifier-discriminator unit is shown in Fig. 1. A pulse-counter discriminator has been used because this circuit not only gives a very low level of distortion but also gives excellent a.m. rejection and is very easy to align. No originality is claimed for the discriminator section (Tr3, 4, 5): this was originally published in *Wireless World* and was later used in a v.h.f.-f.m. tuner described in *Practical Wireless*.

Discriminator Action

This section of the unit looks deceptively simple: it is in fact very simple to build and use, but its operation is quite complex. As it is a rather uncommon circuit we will give a brief description of its operation (for a more detailed account see the July, 1966, issue of *Wireless World*). Tr3 is a straight-

★ components list

Resistors:

R1	220k Ω	C8	68pF 1%
R2	15k Ω	C9	270pF
R3	4.7k Ω	C10	0.01 μ F
R4	22k Ω	C11	0.1 μ F
R5	47k Ω	C12	0.01 μ F
R6	3.9k Ω	C13	100pF
R7	5.6k Ω	C14	5000pF
R8	82k Ω	C15	10 μ F 15V Electrolytic
R9	27k Ω	C16	200 μ F 15V Electrolytic
R10	5.6k Ω	C17	1000pF 1kV
R11	2.2k Ω	C18	1000pF 1kV
R12	220k Ω		
R13	470 Ω		
R14	10k Ω		
R15	2.2M Ω		
R16	2.2M Ω		
All $\frac{1}{4}$ W 10%			

Capacitors:

C1	0.01 μ F
C2	0.01 μ F
C3	68pF 1%
C4	68pF 1%
C5	100pF
C6	0.01 μ F
C7	1000pF

Transformers:

T1, T2 Denco type IFT15

Semiconductors:

D1	AA119, OA70, OA71 etc.
D2	BAY31
D3	BAY31
Tr1	AF126 (or AF114/5/6/7, AF124/5/7)
Tr2	as Tr1
Tr3	BC108 (or BC148 printed-circuit type)
Tr4	as Tr3
Tr5	as Tr3

Three superb Build-it-yourself speaker kits from Wharfedale

You could almost say *design-it-yourself* kits—as each one owes its inspiration to your wishes! In fact, as fast as we issue one kit you ask us for another, till we can hardly keep pace with demand. So if you've a perceptive ear and an eye for real value, make your choice today from the 3 below.

Unit 3

Compact bookshelf system

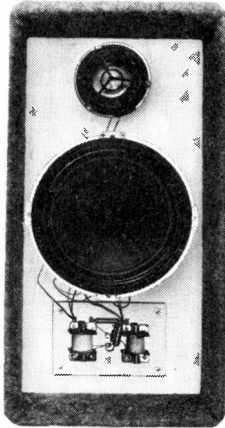

8" Bass/Mid Range speaker and acoustiprene tweeter.
Frequency response 50-17,000 Hz.
Crossover unit.
Rec. Retail Price £13.00



Unit 4

Full range floor-standing system

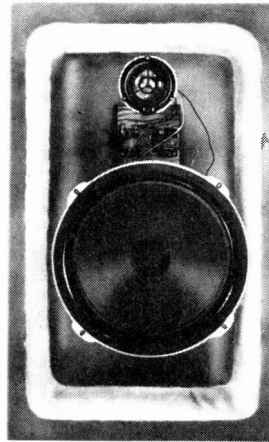

2 speakers (12" Bass and 3" Treble).
Frequency response 45-17,000 Hz.
4-element crossover unit.
Rec. Retail Price £18.00

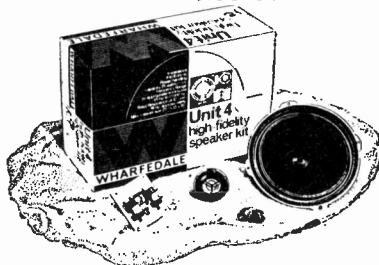

Unit 5

For the real enthusiast

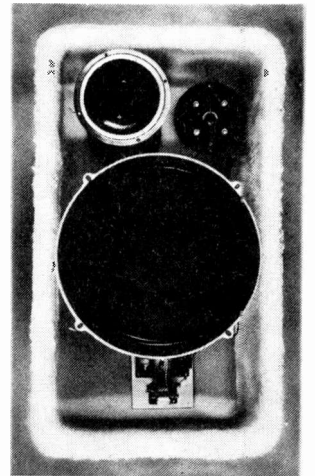

3 speakers (12" Bass, 5" Mid Range, and 1" Treble). Frequency response 40-20,000 Hz.
6-element crossover unit.
Rec. Retail Price £23.50



CUT HERE

To: Rank Wharfedale Ltd., Idle, Bradford.

Please send me leaflets describing your speaker kits.

Name (Block capitals, please).....

Address.....

T.V.

● All kits are complete with speakers, crossover unit, acoustic wadding, mounting bolts and connecting wire, and full assembly instructions. No special technical knowledge necessary.

the true sound in High Fidelity.



WHARFEDALE

Rank Wharfedale Ltd.
Idle, Bradford, Yorks. BD10 8SQ

LAWSON BRAND NEW TELEVISION TUBES



SPECIFICATION: The Lawson range of new television tubes are designed to give superb performance, coupled with maximum reliability and very long life. All tubes are the products of Britain's major C.R.T. manufacturers, and each tube is an exact replacement. Tubes are produced to the original specifications but incorporate the very latest design improvements such as: High Brightness Maximum Contrast Silver Activated Screens, Micro-Fine Aluminising, Precision Aligned Gun Jigging, together with Ultra Hard R.F. High Vacuum Techniques.

DIRECT REPLACEMENTS FOR MULLARD-MAZDA BRIMAR GEC, ETC.

A21-11W (P)	AW47-91 (M)	C19/AK (M)	CME1902 (M)	173K (M)
A28-14W	MW43-64 (M)	C21/1A (M)	CME1903 (M)	212K (M)
A31-18W (P)	MW43-69 (M)	C21/7A (M)	CME1905	7205A (M)
A47-11W (P)	MW43-80 (M)	C21/AA (M)	CME1906	7405A (M)
A47-13W (T)	MW52/20 (M)	C21/AF (M)	CME1908	7406A (M)
A47-14W (M)	MW53/80 (M)	C21/KM (M)	CME2101	7502A (M)
A47-17W (P)	AW47-97 (M)	C21/SM (M)	CME2104 (M)	7503A (M)
A47-18W (P)	AW53-80 (M)	C23/7A (M)	CME2301 (M)	7504A (M)
A47-26W (P)	AW53-88 (M)	C23/10 (M)	CME2302 (M)	7601A (M)
A59-11W (P)	AW53-89 (M)	C23/AK (M)	CME2303 (M)	7701A (M)
A59-12W (P)	AW59-90 (M)	CME1101 (P)	CME2305 (P)	CRM121 (M)
A59-13W (T)	AW59-91 (M)	CME1201 (P)	CME2306 (T)	MW31-74 (M)
A59-14W (T)	C17/1A (M)	CME1402 (M)	CME2308 (M)	A50-120W/R (P)
A59-15W (M)	C17/5A (M)	CME1601 (P)	CRM172 (M)	
A59-14W (T)	C17/7A (M)	CME1602 (P)	CRM173 (M)	
AW36-80 (M)	C17/AA (M)	CME1702 (M)	CRM212 (M)	
AW43-80 (A)	C17/AF (M)	CME1703 (M)	CRM211 (M)	
AW43-88 (M)	C17/FM (M)	CME1705 (M)	23SP4 (M)	
AW43-89 (M)	C17/5M (M)	CME1706 (M)	171K (M)	
AW47190 (M)	C19/10AP (T)	CME1901 (M)	172K (M)	

REBUILT TUBES

LAWSON "RED LABEL" CRTS are particularly useful where cost is a vital factor, such as in older sets or rental use. Lawson "Red Label" CRTS are completely rebuilt from selected glass, are direct replacements and guaranteed for two years.

	Brand New Tubes	Red Label Rebuilt	Carr. Ins.
CME 1601	£8-50	£4-25	12" - 19"
17"	£6-25	£4-87	
19"	£7-25	£5-25	62p
21"	£8-50	£6-87	
23"	£9-75	£7-25	20" - 23"
19" Twin Panel	£10-25		
23" Twin Panel	£15-50		
19" Panorama	£9-38		
20" Panorama	£9-50		
23" Panorama	£11-95		

LAWSON TUBES

18 CHURCHDOWN ROAD, MALVERN, WORCS. Malvern 2100

2 YEARS' GUARANTEE FULL TUBE FITTING INSTRUCTIONS

Tubes are despatched passenger train, road or goods taking far too long for customer satisfaction.

Learn at home... First Class Radio and TV Courses



After brief, intensely interesting study—undertaken at home in your spare time—YOU can secure a recognised qualification or extend your knowledge of Radio and TV. Let us show you how.

FREE GUIDE

The New Free Guide contains 120 pages of information of the greatest importance to both the amateur and the man employed in the radio industry. Chambers College provides first rate postal courses for Radio Amateurs' Exam., R.T.E.B. Servicing Cert., C. & C. Telecoms., A.M.S.E. (Elec.). Guide also gives details of range of certificate courses in Radio/TV Servicing. Electronics and other branches of engineering, together with particulars of our remarkable terms of

Satisfaction or refund of fee
Write now for your copy of this valuable publication. It may well prove to be the turning point in your career.

Founded 1885 Over 150,000 successes

CHAMBERS COLLEGE

(Incorp. National Inst. of Engineering)

(Dept. 844V) Aldermaston Court, Reading. RG7 4PF

NEW VALVES!

Guaranteed and Tested

24-HOUR SERVICE

1R5	87 DK32	83 EF91	18 PL36	49
1R5	81 DK91	87 EF183	27 PL81	46
1T4	18 DK92	41 EF184	30 PL82	31
3R4	28 DK96	88 EL33	46 PL83	34
3V4	37 DL35	23 EL84	24 PL84	31
6/30L2	67 DL92	28 EY51	35 PL500	84
6AQ5	25 DL94	37 EY96	81 PL504	65
6BW7	57 DL96	36 EY90	22 PY32	64
6P23	70 DY85	26 EZ81	23 PY33	64
6P25	60 DY87	28 KT61	46 PY81	25
25L6GT	82 EABC80	11 KT66	82 PY82	25
30C15	62 EB91	11 N78	85 PY80	35
30C18	63 EBC33	38 PC96	48 PY801	35
30F3	78 BF789	30 PC98	49 U19	31
30FL1	62 ECC61	17 PC97	39 U25	65
30FL14	70 ECC82	20 PC900	35 U26	63
30L15	60 ECC83	23 PC84	31 U191	60
30L17	71 ECF80	28 PCC89	46 U251	70
30P4	60 ECF82	28 PCC189	30 U329	70
30P19	60 ECH35	27 PC96	29 UABC80	30
30PL1	61 ECH81	29 PCF86	45 UBFS9	31
30PL14	67 ECL80	33 PCF801	32 UCC83	36
CCH35	65 ECL82	31 PCF802	44 UCH81	32
DAC32	32 ECL86	37 PCF805	63 UCL82	34
DAF91	21 EFP39	29 PCL82	33 UCL83	49
DAF96	33 EFP80	24 PCL84	35 UFP89	30
DF33	37 EFS85	25 PCL85	42 UL84	30
DF91	18 EFS88	31 PCL86	40 UY85	27
DF96	35 EFS89	24 PFL200	54 Z77	18

Postage on 1 valve 5p, on 2 or more valves 3p per valve extra. Any parcel insured against damage in transit 3p extra. Office address, no callers.

GERALD BERNARD

83, OSBALDESTON ROAD
STOKE NEWINGTON,
LONDON, N.16

NEW RANGE U.H.F. - TV - AERIALS

All U.H.F. aerials now fitted with tilting bracket and 4 element grid reflector.
Loft Mounting Arrays: 7 element, £2-25; 11 element, £2-62; 14 element, £3-00; 18 element, £3-50. Wall Mounting with Chimney Arm: 7 element, £3-25; 11 element, £3-75; 14 element, £4-12; 18 element, £4-50. Cranked Mounting Arrays, Complete: 7 element, £4; 11 element, £4-37; 14 element, £4-75; 18 element, £5-25. Complete assembly instructions with every aerial. Low loss co-axial cable, 8 1/2 yd. King Teboaters-Labgear U.H.F. Boosters from £3.75. Belling Lee 'Concord' all Band V.H.F./U.H.F. mains operated pre-amp., £7-50. State clearly channel number required on all orders. P.p.: Aerials, 40p; accessories, 15p. C.W.O. or C.O.D.

BBC - ITV - FM AERIALS



BBC (Band 1): Loft, £1-25; wall 8/1, £1-62; 'H' array, £3-00. ITV (Band 3): 5 element loft array, £2-25; 7 element, £2-75; wall mounting, 5 element, £3-25. Combined BBC/ITV: Loft 1+5, £2-75; 1+7, £3-37; wall mounting 1+5, £3-87; chimney mounting 1+5, £4-50. Pre-amps from £3-75. Combined BBC/ITV/BBC2 Aerials: 1+5+9, £4-00; 1+5+14, £4-50; 1+7+14, £5-00. Available loft only.

FM Radio: Loft 8/1, 87ip, 'H', £1-92; 3 element array, £2-87. Standard co-axial cable, 5p yd. Co-ax plugs, 8ip. Outlet boxes, 30p. Diplexer crossover boxes, 87ip. P.p.: Aerials, 40p; accessories, 15p; C.W.O. or C.O.D. (incl. C.O.D. charge 17ip). 5p for fully illustrated lists. CALLERS WELCOME! OPEN ALL DAY SATURDAY.

K.V.A. ELECTRONICS (Dept. P.T.)

40-41 Monarch Parade
London Road, Mitcham, Surrey
01-648 4884

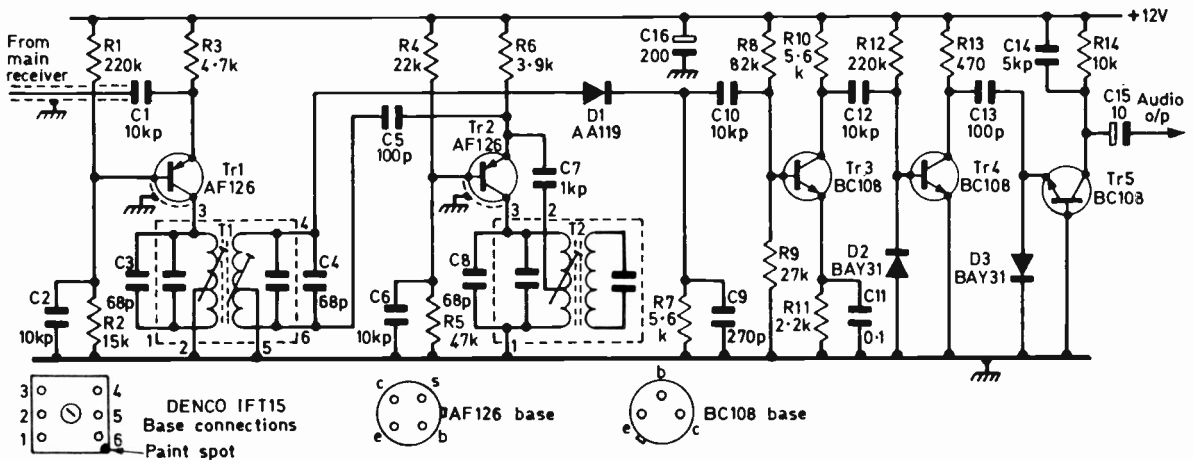

Fig. 1: Circuit diagram of the complete unit

forward driver stage which is necessary because of the low input impedance of Tr 4, which cannot be fed direct from the mixer stage (D1). The signal fed to Tr 4 base is sufficient to switch it alternately on and off. A squarewave whose amplitude is nearly equivalent to the supply rail voltage appears therefore at Tr 4 collector. Diode D2 conducts on the negative half of the input waveform while the diode formed by the base-emitter junction of Tr 4 conducts on the positive half. In this way the charge which builds up on C12 is such that the input is clipped symmetrically on both the positive and negative tips, providing optimum limiting and a suitable input for the discriminator.

When Tr 4 switches off, its collector voltage is about 12V. D3 then conducts and C13 charges. When Tr 4 is switched on its collector voltage drops and C13 then discharges through the emitter-base junction of Tr 5 so that Tr 5 briefly conducts and C14 charges. The higher the input frequency the more often Tr 5 conducts and so the greater is the charge which builds up on C14. In this way an output voltage proportional to the input frequency is obtained.

Frequency Changer Section

In common with all pulse-counter discriminator circuits this requires a low-frequency i.f. input (about 150kHz) and the rest of the circuit is concerned with providing this from the 6MHz input tapped from the main TV set. The first stage Tr 1 uses a pnp AF126 transistor, but the circuitry has been arranged for a positive supply line to facilitate powering from a valve-operated hi-fi system. This first stage has two main functions. It provides little gain but serves as a buffer to prevent signals from the oscillator stage (Tr2) finding their way back into the main receiver and causing picture patterning. Also by virtue of its low collector-emitter voltage it acts as a limiter on strong inputs which avoids overloading the discriminator and reduces the risk of the signal pulling the oscillator. It also provides a low-impedance input suitable for coaxial cable.

The collector is tuned to 6MHz by the double-tuned transformer T1. During initial development this transformer presented some problems when attempts were made to make it by hand. To start with miniature coil formers are not easy for the

amateur to obtain and the standard 0.3in. Aladdin coil formers and cans are rather out of scale with the miniature components of the rest of the circuit. There is also some difficulty in finding and maintaining the correct spacing between windings. Alternative arrangements such as bottom-capacitance coupling are likely to become complex and to involve separate primary and secondary coil cans. I decided therefore to use a commercially available 10.7MHz f.m. i.f. transformer and to place suitable parallel capacitance across each winding to tune it to 6MHz. The transformer used in the prototype was a Denco type IFT15 which required 68pF across each winding. Other similar types may be used but would probably need different value capacitors.

The second stage also uses an AF126 and is arranged as an oscillator operating at about 6.15MHz. Again a Denco IFT15 transformer was used, only one winding being used in this case. Initially some difficulty was experienced in producing a reliable oscillator design with a transformer not intended for the purpose. The circuit shown however has proved completely reliable even at low supply voltages. The oscillator and signal voltages are fed to the mixer diode D1 which produces the required low i.f. for the discriminator. Sufficient output is obtained to feed all but the most insensitive audio amplifiers. De-emphasis is provided by C14. C16 removes all trace of audio from the supply line which would interfere with the stability of the oscillator.

Construction

No detailed layout diagrams have been provided as the layout is not unduly critical and most constructors will probably wish to use a method of construction which fits in well with their existing hi-fi systems. As however this is quite an unusual project some notes on construction and testing follow.

It is best to begin from the output end and construct the stages Tr3, 4 and 5 first. These stages should then be connected to the amplifier and a 9V or 12V battery connected, preferably via a meter. The consumption should be about 20-25mA, most of this being taken by the limiter stage Tr4 because of its low-value collector load. On connecting a wire aerial to the free end of C10 a jumbled mass of medium- and long-wave stations should be heard,

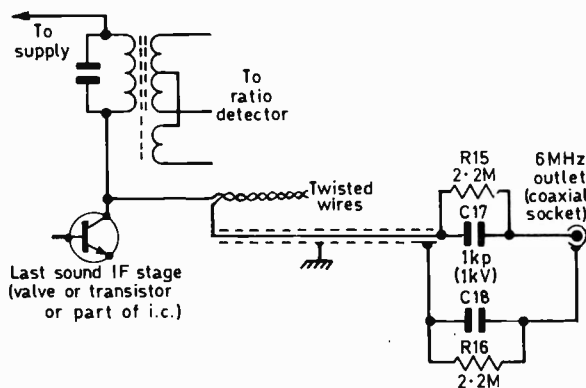

Fig. 2: Tapping the sound from the main receiver

probably quite distorted if the limiter is working correctly.

Stages Tr1 and Tr2 and the mixer may then be wired up. Take care in wiring in the AF126 transistors since their connections are not quite in the order you might expect, see Fig. 1. The top (secondary) core should be removed from T2. When drilling the mounting holes for T1 and T2 ensure that the centre hole is large enough to enable the lower core to be withdrawn as these IFTs have a habit of peaking up with the cores slightly out of the coil formers. Also ensure that the IFTs are mounted correctly as it is difficult to see the paint spot near pin 6 once they are on the board or chassis. On retesting the unit the current consumption will be a little increased by the addition of Tr1 and Tr2. A convenient way to test the local oscillator is to tune it in on a short-wave radio set (around 50 metres). The tuning of T1 is best left until a 6MHz signal is available.

Connections to the Main Receiver

Now we come to the tricky part—obtaining a 6MHz signal from the main TV set. The way in which this is done is shown in Fig. 2. A 3in. length of single-core connecting wire is soldered to the collector—or anode—of the final sound i.f. stage. A length of coaxial cable is terminated in a similar piece of wire, its screen being bonded to chassis. The pieces of wire are then twisted together to form a very low-value variable capacitance. In conjunction with the capacitance of the coaxial cable this provides a capacitive tap on the primary of the ratio detector transformer to give a low-impedance output. For safety reasons it is necessary to isolate the output socket from the receiver's live chassis and this is done using high-voltage 1kV capacitors with a discharge path provided by parallel 2.2M Ω resistors. This is of course identical to a conventional aerial isolator panel and probably an old one can be found in the spares box (but check that the capacitors are not shorted!).

Alignment

Having connected this to the sound unit some sort of output should be obtained. If not, try tuning the fine tuner so that sound-on-vision begins. This should provide a stronger output though with a great deal of vision buzz. Return the fine tuner to the normal

position as soon as possible however. First peak the cores of T1 for maximum *sound* output (*not* maximum d.c. voltage across R7: at this stage this will consist mostly of vision and oscillator signals). Then tune T2 for the clearest sound. When it is correctly tuned the sound will come through very clearly indeed with very low background noise. There will be two tuning points for T2 core: choose the one with the core farthest out. Next untwist the twisted wires in the main set until the signal is very weak: then readjust the cores of T1. Finally twist the wires together again until the signal is of good strength. Do not twist them together more than necessary as this will detune the set's ratio detector coil; also the gain may become so high that the inter-station noise when tuning between stations becomes deafening. Try tuning the set to a weak station to ensure that the gain is adequate to receive sound on all signals which give a reasonable picture. Also check that the set's own sound section still works normally with and without the sound unit plugged in.

Conclusion

If carefully aligned and the output fed into a good amplifier this unit will give sound quality equal to a good-quality v.h.f. radio set: in fact it can be used equally well to improve the quality of a v.h.f. radio receiver by connecting it to the ratio detector transformer primary as above. In this case the 68pF capacitors across the coils should be omitted.

To return finally to the unit's original purpose, it is advisable to use a speaker placed below the TV set in order to obtain sound coming from the same direction as the picture! Otherwise it appears that the announcer is able to throw his voice!

No difficulty should be experienced in connecting up to the main set except in the few cases where an i.c. sound channel is incorporated. However most of these use a conventional ratio-detector transformer and the remarks made earlier therefore apply. ■

NEXT-GENERATION TV SETS

At the *Salon International des Composants Electroniques*, Paris, Mullard showed the latest TV set designs to emanate from their Central Application Laboratory. As Mullard designs are frequently adopted by some of the setmakers this gives us an idea of what lies ahead in the not too distant future. On show were an all solid-state monochrome receiver which gives a performance comparable with the current generation of hybrid designs, using a BU105 high-voltage silicon transistor in its line output stage, and an experimental 110° deflection colour receiver—the present range of shadowmask tubes have 90° and 92° deflection angles. This set makes full use of the recently introduced range (see *Teletopics* March 1971) of Mullard i.c.s for colour receivers. The transistorised line timebase operates from a 240V rail taken from a stabilised thyristor power supply circuit working directly from the mains. The heater supply for the c.r.t. is derived from the line timebase so a separate mains transformer is not necessary. A silicon tripler provides the 25kV e.h.t. supply. Current-difference drive is applied to the deflection assembly to correct convergence errors in the extreme corners of the picture.

COLOUR RECEIVER CIRCUITS

LUMINANCE CIRCUITS

GORDON J. KING

LAST month we looked at the Bang and Olufsen luminance preamplifier circuit and to follow up logically Fig. 1 shows the circuit of the luminance output stage used in this chassis. To make the principle of operation quite clear the circuit is presented in simplified form.

The output valve is a 12HG7 pentode and the luminance (Y) signal from the emitter of the final transistor in the preamplifier circuit is fed direct to its control grid to preserve the d.c. component of the signal. D.C. continuity is also maintained right up to the picture tube cathodes. The luminance signal is developed across the anode load resistor which is R2 in this simplified diagram and passed to the cathodes of the shadowmask tube via switch S1 (a service switch), the presets VR1, VR2 and the resistive potential-divider R5, R6 (or R7). To get an idea of the d.c. condition at the three tube cathodes—this determines the black level of the Y signal—first consider the circuit with S1 open. This removes the Y drive from the tube cathodes yet retains the potential corresponding to the black level of the drive. This happens because the potential divider R3, R4 clamps all three cathodes to a potential of about 230V. This potential at the junction of R3, R4 is applied to the cathodes via the far sides of presets VR1, VR2 and the potential-divider R5, R6.

When switch S1 is closed the voltage drop across R2 at black level is the same as the potential existing at R3, R4 junction, which means that the black-level potential is maintained. As however the luminance signal developed across R2 varies so the cathode of the tube will swing away from the black level. The luminance signal is applied to the three tube cathodes from the sliders of VR1 and VR2 and the junction of R5, R6, these presets providing Y-signal drive regulation.

It will be seen that the red cathode can be connected to the junction of R5, R6 or to R7 by changing the tapping point. This provides adjustment for

tubes whose red phosphor has lower or higher efficiency than average. Once the red cathode preset adjustment is made (since the red phosphor is the least efficient) VR1 and VR2 are adjusted for correct balance between the three beams: the idea is for a monochrome drive signal to illuminate the red, green and blue phosphors on the screen of the tube in the correct balance to yield white light (the white light reference being illuminant D which is close to the North sky at noon).

The bias for the 12HG7 is mostly provided by the brightness control circuit which is in a potential-divider chain across potentials of -70V and -20V . The cathode of the valve is taken to chassis via a resistor of 22Ω . Thus the current flowing through the valve's anode load and hence the voltage drop across it applied to all three tube cathodes is under the brightness control's influence. In this manner the illumination provided by all three c.r.t. beams can be simultaneously altered and provided the characteristics of the three guns are reasonably well matched and the preset adjustments for gray-scale tracking correctly set up the control will take the raster from black (zero illumination) to peak white.

Diode D1 and its associated components constitute part of a beam-current limiter circuit. The voltage at A is nominally 100V and is applied to the bottom end of the potentiometers which supply the picture tube first anodes (used to make the black level or tube cut-off gray-scale tracking adjustments). Should the beam current tend to rise in excess of 1.5mA for a period exceeding 200mS (determined by the time-constant R8/C1) D1 cathode will become less positive and the diode will conduct. This changes the potential at the bottom of the first anode potentiometers and automatically turns the beam current down to a safe value.

The output at B constitutes a reference potential derived essentially from the voltage-dependent resistor (v.d.r.). This is applied to the d.c. clamps in the picture tube control grid circuits. The arrangement is such that any change in d.c. conditions at the tube cathodes will be reflected as counteracting changes in the d.c. conditions at the grids. In this manner stabilisation is provided against mains voltage etc. variations so that the voltages at the cathodes and control grids of the picture tube will remain constant with respect to each other.

Tube Drive Techniques

The majority of receivers with colour-difference drive employ transistor preamplifiers for luminance followed by a power pentode valve. This arrangement makes it easy to secure the required Y drive at the cathodes. One or two circuits have been evolved for complete transistorisation of the luminance

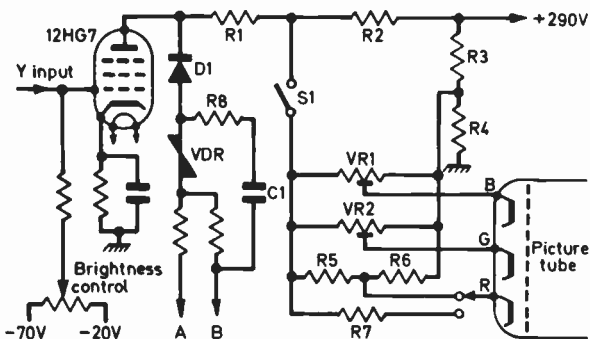

Fig. 1: Simplified circuit of the luminance output stage in the Bang and Olufsen 3000 chassis.

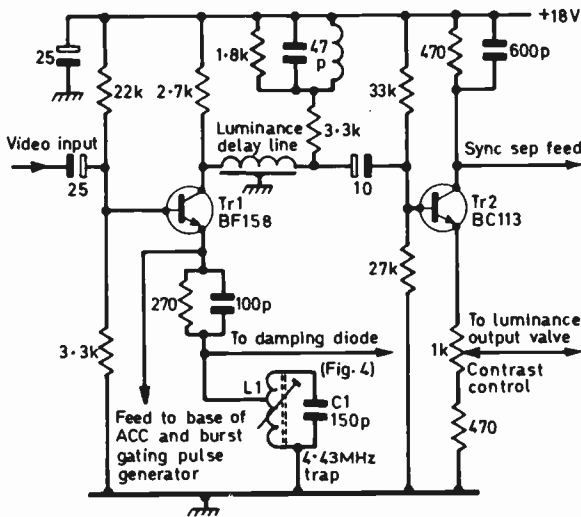

Fig. 2: The luminance preamplifier stages of the Decca CTV25 dual-standard chassis.

ance channel but one of the problems has been in getting transistors with suitable collector voltage ratings, for the video swing required cannot be obtained from supply rails of limited voltage. The supply must of course exceed the video drive requirement!

Relatively high-voltage video power transistors have nevertheless appeared on the scene but the trend in recent chassis is towards primary-colour drive using separate red, green and blue primary-colour amplifiers, one for each gun. This puts less demand on the drive transistors. Circuits of this type will be discussed later. For the moment we will keep to the colour-difference drive system and have a look at some other aspects of the luminance channel.

Decca Luminance Preamplifier

Figure 2 shows the circuit of the Decca (early model) luminance preamplifier. There are two transistor stages the first of which receives the Y signal from the detector while the second receives the amplified signal from the collector of the first one via the luminance delay line. Optimum coupling to the luminance output valve is achieved by running the second transistor in the emitter-follower mode as shown here.

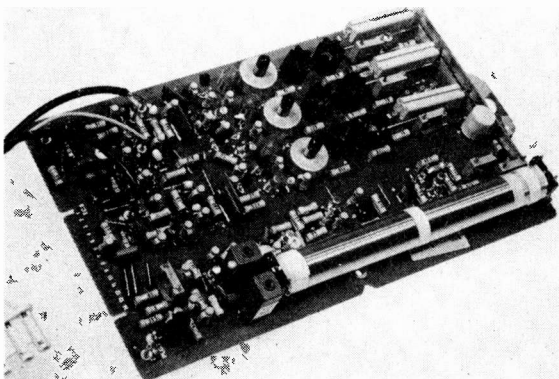

Fig. 3: The video module of the BRC all-transistor dual-standard chassis (2000 series). The luminance delay line is at the bottom right.

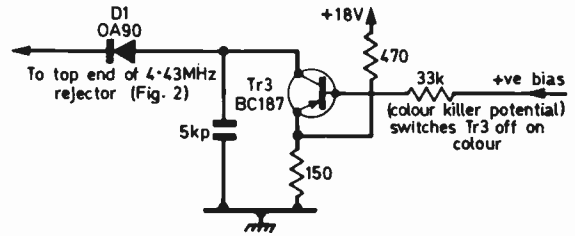

Fig. 4: Auto switching circuit for the chroma rejector in the Decca luminance preamplifier (Fig. 2).

The contrast control sets the amount of luminance signal fed to the control grid of the output valve.

Luminance Delay Line

The value of the luminance delay required differs between receivers. This is because of differences in the passband characteristics of the Y and chroma channels in different chassis. It will be recalled that Y delay is necessary to "slow down" the signals in the wider passband Y channel so they arrive at the picture tube at exactly the same time as the signals in the narrower passband chroma channel. A delay of the order of 800nS (1nS equals 10^{-9} sec) represents an average figure. A good picture of what a Y delay line is like can be seen in Fig. 3 which shows the BRC video module: the delay line is the long, wound component at the bottom of the module.

Chroma Rejection

All luminance channels embody a high-Q or notch type filter for sucking out the chroma subcarrier. The presence of the chroma signal in the luminance channel is undesirable for various reasons, the prime one being to avoid undue beat interference which can emphasise dot patterns on the display. To avoid this filter impairing the quality of the monochrome display it is sometimes automatic in operation, coming into action only when chroma components (i.e. the colour bursts) are present in the received signal. The deleted slice of Y signal on colour is of course balanced by the extra information provided by the chroma signal, but on monochrome no such balancing signal exists which means that the filter is bound to impair the definition of detail (although it is focused on to 4.43MHz, the subcarrier frequency, its response is bound to spread out a bit and thus take down signal either side of this frequency).

Last month it was shown how the filter is automated in the Bang and Olufsen chassis. In the Decca circuit a slightly different arrangement is adopted. It will be seen (Fig. 2) that the tuned rejector L1, C1 is included in the first transistor emitter circuit (a common place for it). As shown it is always in circuit. However a connection from the high-impedance side (top of L1 and C1) is connected to an OA90 diode shown in Fig. 4. The plan is to get this diode to appear in shunt with the tuned circuit on monochrome thereby taking the first transistor emitter direct to chassis and thus out of the influence of the rejector.

It happens like this. Transistor Tr3 controls the conduction of diode D1, switching it on by reflecting the positive potential at its emitter via its collector and hence to the anode of the diode. On monochrome

using the Oscilloscope

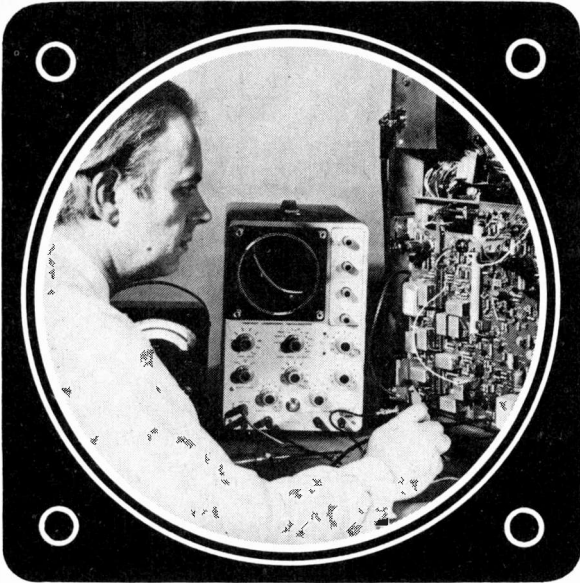

PART 2 KEITH CUMMINS

IN Part 1 we dealt with the oscilloscope in general. Now we must look at some details of its operation. It seems appropriate to start off by mentioning the probe. Readers will be aware that use of a measuring instrument inevitably loads the circuit under test. A meter for example draws a small current while measuring voltage.

The input circuit of the oscilloscope appears as a d.c. resistance shunted by capacitance. The use of a screened input lead adds to the capacitance which since it has a shunting reactance dependent on frequency distorts our readings in both amplitude and shape if the waveform contains harmonics. The extent to which the waveform is degraded depends upon the impedance of the circuit under test. Low-impedance circuits are hardly affected while the effect on high-impedance circuits can be devastating.

Signal Probe

A typical scope input consists of $1\text{M}\Omega$ in parallel with 30pF . The addition of a screened input cable

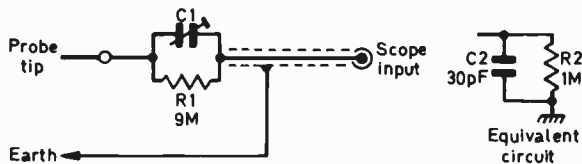

Fig. 1 : Oscilloscope probe circuit and, on the right, the scope input equivalent circuit.



(a) Ideal square wave (b) Poor HF response (c) Excessive HF response

Fig. 2 : Effects of inadequate response on a squarewave signal.

will increase the 30pF to possibly $60\text{-}100\text{pF}$. This complex impedance is obviously undesirable when connecting the scope to some circuits, and it is under these circumstances that a probe is useful. A typical circuit is shown in Fig. 1.

The probe consists of a probe tip connected directly to components R1 and C1. So far as d.c. is concerned R1 in association with R2 in the scope forms an attenuator which increases the input impedance tenfold at the expense of having to use ten times the gain in the scope. C1 also forms the top half of a divider, this time in conjunction with C2 and the capacitance of the screened cable. By this means the frequency response of the probe circuit is maintained. The nominal capacitance of C1 is one-ninth of the total input capacitance mentioned above. In order that C1 may be optimised, it is made variable.

The probe is set up using a squarewave input at say 50Hz . It can be shown (by Fourier analysis) that a squarewave consists of a fundamental sinewave of the same frequency plus an infinite series of harmonics. Thus a squarewave will only be passed unscathed through an amplifier having a flat frequency response. The effects of inadequate response are shown in Fig. 2.

Using the calibration squarewave in the scope, the Y amplifier input is first checked to see that the calibration is correct. The squarewave is then applied to the probe. The scope input sensitivity is increased by a factor of ten to restore the trace amplitude and C1 in the probe adjusted to obtain as perfect a squarewave as possible. Excessive capacitance will produce a trace similar to Fig. 2(c) while insufficient capacitance will result in a trace like Fig. 2(b).

So it will be seen that the use of the probe increases the input impedance of the oscilloscope by a factor of ten. This enables us to connect the scope to sensitive circuits with minimal disturbance. We are still limited however since the extra capacitance may still be enough to upset r.f. circuits. In addition of course our scope's sensitivity has been reduced by a factor of ten and this is not always desirable. Nevertheless the probe is a very useful device for extending the use of the oscilloscope.

More sophisticated probes use active devices (i.e. valves or transistors) to avoid the need for attenuation while still increasing the input impedance. Such probes are however far more likely to suffer damage from mishandling than their simpler passive counterparts.

Lissajous Figures

So far in our examination of the oscilloscope we have always assumed the use of a linear X timebase, i.e. that the X circuits move the trace from left to right at a constant speed. When the trace reaches its maximum deflection to the right it is then very rapidly swept back to its starting point at the left and repeats its cycle. As described in the previous article this enables us to plot a graph of amplitude against time.

This is not the only way in which the cathode-ray

tube can be used to display a frequency relationship. Two signals can be compared by applying them respectively to the X and Y deflection circuits. If the signals are sinewaves they will each produce a motion of the trace which is termed a "simple harmonic". Two simple harmonic motions combined at right angles to each other (our X and Y plates) are of course at right angles) produce a display known as a Lissajous figure. Lissajous figures can be used to assess phase and frequency differences and are illustrated in Fig. 3.

When the ratios of the frequencies concerned are small whole numbers the figures are of a simple nature and can be interpreted quite easily. Fig. 3 shows how with identical frequency ratios the figures appear differently depending upon the relative phases of the signals. If the frequency ratio is complex, for example 9:8, the Lissajous figure becomes very complex and difficult to interpret. Experiments using a 50Hz mains-derived sinewave and a locally generated variable frequency can be both instructive and entertaining. Note how in Fig. 3 the ratio of the frequencies can be assessed by counting the number of loops in the figure.

PDA Tubes

Last month we considered the two basic modes of timebase operation, synchronised and triggered. Very often if we are observing an infrequent event using the triggered mode of operation the brightness of the tube needs to be very high: Simple oscilloscopes using e.h.t. voltages of around 1.5kV generally perform inadequately under these conditions. In order to obtain more brilliance the e.h.t. voltage has to be increased. An increase in e.h.t. however does not solve the one problem without introducing another. The more e.h.t. we have the faster the electrons in the beam travel and the more energy they dissipate on hitting the phosphor screen. This provides the extra brilliance we are looking for. Unfortunately this fast-moving electron beam is also "stiffer" and thus

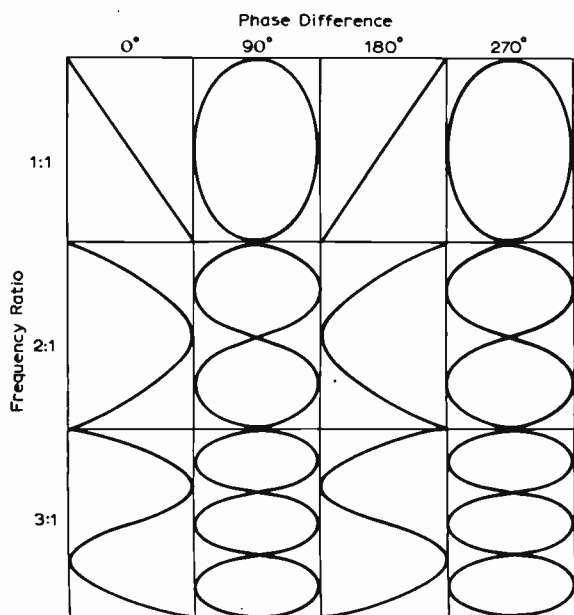
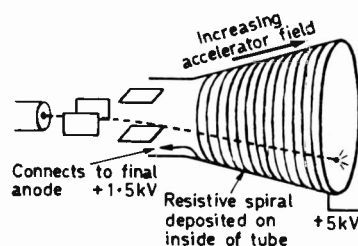

Fig. 3: Lissajous figures.

Fig. 4: The post deflection acceleration tube.



requires correspondingly larger deflection voltages applied to the tube's deflection plates if the same deflection displacement is to be maintained. Thus it will be seen that if we increase the e.h.t. more powerful deflection circuits are needed for the X and Y directions.

Deflection circuits are not easy to design and the provision of larger linear voltage swings can make the scope designer's life very difficult. Because higher voltages are present higher h.t. supplies and higher rated components are all needed. It is at this point that the p.d.a. tube provides an answer. P.d.a. stands for *post deflection acceleration* and the principle employed is illustrated in Fig. 4.

The flare of the c.r.t. has a resistive spiral deposited on its inside. The resistance can typically be of the order of 100MΩ. The end nearest the deflection plates is connected to the final anode of the tube while the end nearest the screen is taken to an e.h.t. supply of around 5kV. The electron beam emerging from the gun is travelling at the "normal" 1.5kV rate and is therefore quite easily deflected. Having passed between the plates the beam comes under the influence of the accelerator spiral, which of course has a potential gradient across its ends. The farther the beam travels towards the tube face the stronger the accelerating field becomes, so that the final velocity of the electrons is very high.

A significant increase in brilliance results while the deflection sensitivity of the tube remains the same. As with most things however there is a catch, namely that the tube has to be very carefully designed in order to avoid geometrical distortion of the trace caused by lack of field uniformity. In some tubes an additional electrode (for example an interplate shield) is introduced to correct geometrical distortion.

Other methods of obtaining high deflection sensitivity consistent with high trace brilliance have been evolved. One of these involves the use of a screening mesh interposed between the deflection plates and the anode of the electron gun. This enables high sensitivity to be obtained since the field of the accelerating voltage cannot pass through the mesh and affect the beam velocity as it passes between the deflection plates. Such tubes are expensive however and find application in wideband oscilloscopes, i.e. those with bandwidths over 25MHz. Oscilloscopes using this technique are now available with bandwidths up to 500MHz.

Double-beam Scopes

Returning now to our typical "workaday" scope with a 5 or 7MHz bandwidth we will find that most modern instruments employ a p.d.a. tube costing up to £20. Very often the oscilloscope has a double-beam facility and we shall now examine this in detail.

It is very useful to be able to display two events

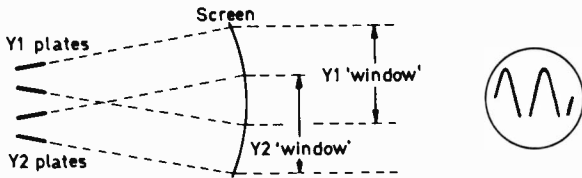

Fig. 5 (left): Illustrating "window effect" in a double-beam tube.

Fig. 6 (right): Window effect on a centred Y1 trace.

simultaneously on an oscilloscope. The relationship existing for example between timebase locking and sync pulse amplitude can be easily determined. It is also possible to examine phase relationships. A double-beam oscilloscope displays two traces, Y1 and Y2, one above the other on the tube face. Each trace has its own input attenuators and shift control. The X timebase however sweeps both beams so that coherence of the displayed events is maintained.

Two basic techniques are in use to provide the double-beam facility. The first employs a double-beam tube with two electron guns, one for each trace. The guns are mounted one above the other on the axis of the tube and each has its own set of deflection plates although the X plates may be paralleled up inside the tube so that only two X connections are available at the tube base. Each trace has its own brightness and focus control and the arrangement may be accurately likened to having two separate oscilloscopes except that they share a common timebase. The timebase may be synchronised from Y1, Y2 or an external source, a selector switch being provided for the purpose.

Double-beam tubes usually suffer from what is termed *window effect*. This is illustrated in Fig. 5 where it will be seen that the displacement of the two guns away from the centre axis of the tube results in the area of the tube face covered by each gun being restricted. The restriction occurs as a result of the limited angle of deflection possible between the Y deflection plates in each case.

Therefore the top trace Y1 cannot be shifted to the bottom of the screen but will disappear approximately two-thirds of the way down because the beam then collides with the lower Y deflection plate. Similarly the Y2 trace cannot be moved to the top of the screen. Generally this is not very detrimental except when one trace is turned off and the other moved to the centre of the screen. Under these conditions a full-screen display cannot be obtained, the effect on a sinewave being illustrated in Fig 6.

The other method of dual display uses a single-beam tube with some complication of the electronics. A block diagram of the technique employed is shown in Fig. 7. The early stages of the Y1 and Y2 channels are separate as in an oscilloscope using a double-beam tube. An electronic switch however selects either the Y1 or the Y2 signal—along with its appropriate shift voltage—and applies it to the final deflection amplifier. The electronic switch is controlled by a switching voltage derived from one of two sources. It should be appreciated that the electronic switch can be likened to a single-pole changeover relay, the sense of the switching voltage determining whether it is the Y1 or Y2 signal which is selected.

The first switching source is a squarewave oscillator which can be free-running or synchronised from the timebase. The important fact is that the square-

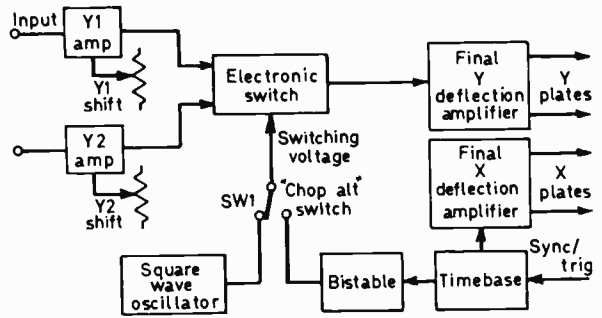

Fig. 7: Block diagram of a switched-signal dual-trace oscilloscope.

wave is generated at a rate which is much faster than the timebase sweep. This signal "chops" the beam into two parts, alternating between Y1 signal and Y2. For relatively slow timebase speeds the chopping action is so fast that two apparently unbroken and independent traces exist. A magnified illustration of the action is shown in Fig. 8. This magnified view of the chopping action would actually appear on the tube face with a fast timebase speed and to avoid this the alternative "alternating-sweep display" mode is used at higher timebase velocities.

For higher timebase velocities the squarewave chopper is switched out and the bistable shown in Fig. 7 substituted for it. The flyback pulses from the timebase switch the bistable from one condition to the other so that in fact it behaves as a divide-by-two circuit. Thus for every two timebase sweeps the bistable output is first in one sense and then in the other. The Y1 and Y2 signals are therefore selected alternately on alternate sweeps, the timebase scanning first one and then the other. No chopping waveform can appear to upset the display and again the two traces appear to be totally independent of each other.

It will be realised that the alternate-sweep mode of operation is not satisfactory at slow sweep speeds as the alternation would be clearly visible. In fact at medium speeds the flicker rate is doubled while at slow speeds two separate scans are seen. Comparative examination of waveforms under these conditions is impossible. The reader will now realise that the chopping and alternating trace techniques are both needed in the one oscilloscope to cope with slow and fast timebase velocities respectively. The change of mode is usually carried out by a section of the timebase coarse speed adjustment switch.

While the electronics of a double-beam oscilloscope using a single-beam tube are more complex the cost of this complexity is offset by the cheaper tube required. In fact the technique may be more economical overall than using a twin-beam tube. Separate brilliance control of the two "beams" is not usually possible although by varying the mark-to-space ratio of the chopping squarewave more of one signal than the other will activate the screen. No equivalent manipulation is possible for the alternating-trace mode however so usually no attempt is

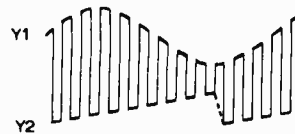

Fig. 8: Showing the chopper action which produces two traces on a single-beam tube. The vertical movements are so fast that they are not visible.

made to provide independent brilliance adjustments. In this latter respect the chopper oscilloscope must be considered inferior to one using a double-beam tube. The double-beam tube does suffer some geometrical distortion however so that even if the two beams are superimposed for time interval assessment between traces some error may exist. This problem does not exist with a single-beam tube for under these conditions the tube virtually reverts to single-beam operation—and the single beam cannot be at variance with itself! Thus there are advantages inherent in both the double-beam techniques and each has its adherents.

Where is the Spot?

Whichever internal system is employed the use, application and manipulation of the oscilloscope follows the same basic pattern. The situation which confuses most novices when confronted by an oscilloscope is a blank screen although the power is switched on. A simple, logical approach to the instrument is all that is necessary. Very often panic sets in when turning up the brilliance produces no results. It is best at this point to consider the possibilities of mal-adjustment. The worst case could involve the shift controls having moved the trace completely off the screen and a stalled timebase so that we can imagine a spot somewhere several inches off the face of the tube. The problem is to find it. A simple approach involves turning the brilliance fully up and setting the focus control to one end of its travel. A large defocused spot (or line if the timebase is running) is then produced and a two handed manipulation of the X and Y shifts should bring it into view. Once this is on the screen brightness, focus, shift, gain, velocity and sync/trigger adjustments should resolve a sensible display.

Displaying Video Waveforms

In addition to the usual internal/external sync and trigger arrangements some oscilloscopes employ TV sync separator circuitry to enable the instrument to display video signals locked to either the line or field sync pulses. The facility is provided on extra positions of the sync/trigger selector switch. Without this facility the display of video signals can be difficult owing to the complexity of the waveform and if possible external synchronisation should be used. This can be picked up quite easily by taking the sync/trigger lead and placing it in proximity to the line circuits of the television set under test. Care should be taken to ensure that the lead cannot come into contact with high-voltage points—the oscillo-

scope could be damaged by such contact. Alternatively the sync separator output from the television set can be used to synchronise the oscilloscope.

The oscilloscope is very useful for examining the behaviour of video, sync and timebase circuits, often saving hours of trial and error approach to a problem. The setting up of colour television decoders demands an oscilloscope and no adjustments should be attempted without it.

Y Circuits

Circuits used in oscilloscopes show great variation from one type of instrument to another but the basic principles are constant and worth considering. Dealing first with the Y deflection circuits we have seen that d.c. coupling is necessary, the option of a.c. coupling being provided by a switchable series capacitor at the amplifier input terminal. Therefore the d.c. coupling must be maintained from the input attenuator onwards. It is also necessary to have a d.c. shift facility—the Y shift control—and it is in this application that the circuit known as the long-tailed pair comes into its own.

This circuit is shown in its very simplest form in Fig. 9. Readers will recognise it as being similar to the double-triode phase splitter used to drive the output valves in many a valve audio amplifier. Each triode anode drives a Y plate of the tube. A positive input to the grid of V1 causes more current to flow through it, causing its anode potential to fall and its cathode potential to rise. The rise in the potential across the common cathode resistor R3 biases V2 more heavily since its grid potential is set by VR1: V2 in fact conducts less heavily by an amount of current equal to the original increase in V1. Therefore if the anode load resistors R1 and R2 are equal in value an opposite voltage change occurs at V2 anode compared to V1 anode. By this means a symmetrical "push-pull" drive is applied to the tube plates. As the whole stage is balanced, changing the voltage at V2 grid will also cause deflection of the trace and it is at this point that the Y shift voltage is introduced. This voltage can therefore be effectively added to or subtracted from a d.c. level present in the signal to be displayed so that the trace may be suitably positioned.

In a modern oscilloscope V1 and V2 would be pentode valves, probably feeding cathode-followers coupled to the tube's deflection plates. By this means the bandwidth is greatly increased, and it should be appreciated that the modern oscilloscope's deflection circuits resemble video amplifiers more than anything else. ECF80 triode-pentode valves have been extensively used in deflection circuits of this type. Symmetrical deflection circuits also have the inherent advantage that they are less susceptible to drift than their "single-ended" counterparts. Drift in d.c. amplifiers is always a potential problem, especially as any change in levels in an early stage will be amplified by the later ones. Feedback circuits can be used to reduce drift and increase bandwidth, resulting in the rather complex arrangements often found in commercial instruments.

Timebase Generator

We now come to the timebase generator. In its basic form the circuit shown in Fig. 10 serves to

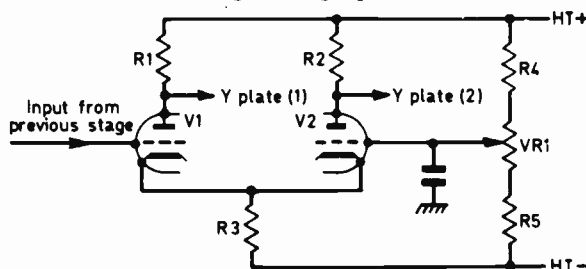

Fig. 9: Long-tailed pair circuit providing differential drive to the Y plates.

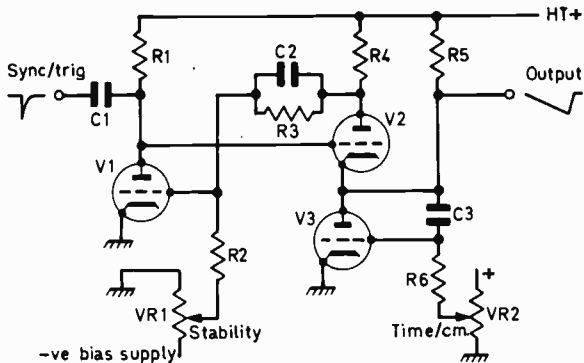

Fig. 10: A commonly used timebase circuit in oscilloscopes, the Miller timebase.

illustrate the technique employed. The output waveform, a negative-going sawtooth, is produced by the charge and discharge of C3. The flyback occurs when V2 is conducting so heavily that C3 charges rapidly to about h.t. When V2 is subsequently cut off C3 discharges via R6 and VR2. Now as C3 is connected between the anode and grid of V3 a negative-feedback action starts in this stage and as a result a linear negative-going sweep appears at V3 anode. Let us look at the circuit in greater detail.

In the triggered mode the circuit is started by applying a negative pulse to the input capacitor C1. The condition prior to the application of the pulse is stable or unstable, determined by the bias applied to V1 via the stability control VR1. Assuming the condition to be stable, V1 is cut off. As a result its anode potential is high. This potential is conveyed to the control grid of V2 which conducts via its anode load R4 and V3. The grid of V3 is positively biased via R6 and VR2. Thus the potential at the cathode of V2 (also the anode of V3) is fairly high. It should also be appreciated that a positive voltage from V2 anode is applied via the divider R3 and R2 to the grid of V1. This positive bias however is insufficient to overcome the negative potential applied to the bottom end of R2 by VR1. With V2 conducting C3 charges.

The negative trigger pulse applied to C1 is conveyed to the grid of V2 which is thereby turned off. The voltage drop across R4 is substantially reduced, resulting in the application of a higher positive voltage to the divider R3, R2. This increased positive voltage overcomes the negative bias at the grid of V1 so that V1 is turned on. As a result V1 anode voltage falls substantially and because V1 anode is connected to V2 grid V2 is kept cut off. The anode of V3 tries to drop in potential but the drop is conveyed via C3 to its grid where it tends to cancel the positive bias applied via R6. C3 therefore discharges slowly and linearly and most readers will recognise this to be a classical Miller integrator action brought about by the negative feedback via C3 from anode to grid of V3.

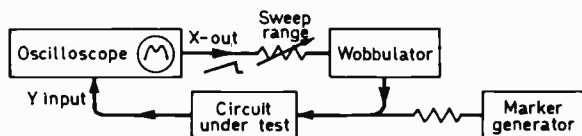

Fig. 11: Frequency response display using an oscilloscope and wobbulator.

C3 continues to discharge and so produces the linear falling ramp output waveform shown in Fig. 10. As C3 discharges V3 grid is driven positively and its anode voltage falls. Eventually V3 anode potential falls below the grid potential of V2. V2 then conducts and the increased voltage drop across R4 results in more bias being applied to V1 grid so that V1's anode potential rises. The effect is cumulative so that the circuit rapidly reverts to its original state with C3 charging via V2 and the grid-to-cathode diode effect of V3. This latter event accounts for the flyback action.

When a free-running timebase is required the stability control VR1 is advanced so that under static conditions V1 is just turned on. The synchronising action is similar to triggering. C2 holds a charge and V1 is cut off until C2 has discharged via R3 when another sweep commences whether or not a synchronising pulse has been applied. The flyback action occurs as in the triggered mode. C2 is only needed for the free-running application of the timebase.

Varying the applied positive voltage from VR2 to R6 controls the rate of discharge of C3 and hence the velocity of the timebase. The amplitude of the ramp waveform is a function of the cut-on point of V2 and is therefore not affected by either VR1 or VR2. This is an important condition which ensures that the trace length is constant irrespective of velocity. In order to provide a wide range of speeds capacitors C2 and C3 are usually switched between ranges in order to provide manageable time-constants in association with the resistor values used in the circuit.

Finally readers should note the circuit shown in Fig. 10 has been simplified in order to illustrate the principle of operation. Oscilloscope circuits usually employ a pentode valve for V3, with involved switching arrangements, making the circuit seem far more involved. A negative-going squarewave is available at V1 anode and this can be used to blank out the flyback on the face of the tube by a suitable connection to the tube grid. This squarewave can also be differentiated to produce the pulses required to operate the bistable circuit of a switched-beam oscilloscope.

Additional circuits required include the X amplifier, which is generally a long-tailed pair amplifier driven from the output of the timebase, and a sync or trigger pulse shaping circuit which provides constant-amplitude trigger pulses for the timebase. This operates by taking an external waveform or a sample from either the Y1 or Y2 inputs and producing a pulse constantly at a given point during that waveform. By this means a stable display is presented.

Use with Wobbulator

Most oscilloscopes have an X-out connection. This facility enables a ramp waveform derived from the X timebase to be fed into ancillary test equipment, usually a wobbulator (otherwise known as a frequency swept oscillator). The ramp waveform is employed to operate a variable-capacitance circuit (usually a varicap diode or reactance modulator) placed across a variable-frequency oscillator.

The collective arrangement of oscilloscope and wobbulator is used to visually display the response curves of tuned circuits—i.f. amplifiers etc. The

—continued on page 328

**Still waiting for spares Tom ?
You should have phoned 01-567 5400
01 567 2971**

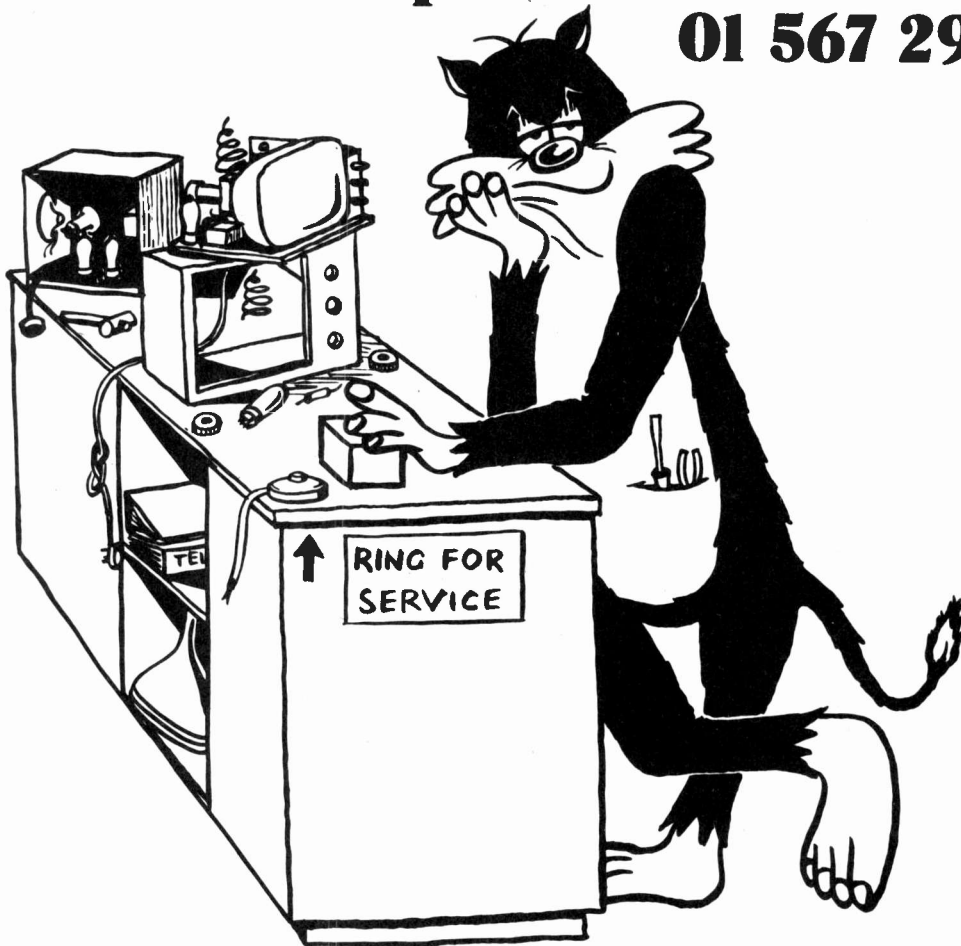

Every time you need spares, don't be like Tom, contact the No.1 wholesaler to the service engineer. For quality, price & availability you must try....

'WILLOW VALE'

4 & 5 The Broadway, Cherington Road, Hanwell, London, W.7.
also at 42 West End, Street, Somerset.

& Scotland

By Return Despatch

Valves, Tubes, LOPTs, Transistors,
Components, Scan Coils Etc.

SERVICING TV RECEIVERS

—continued from page 313

heating check V402 (ECC82) by replacement (swapping V402 and V401 over is a quick but possibly dubious check).

If the overheating is not severe the ECC82 may not be at fault and line drive may be present at the output valve control grid. In this event first try removing the top cap of the PY800. If this restores some sort of line timebase operation the boost line capacitor *could* be shorted (this is C415, just to the lower right of the system switch). In the vast majority of sets removal of the PY800 top cap will restore some e.h.t. if the boost capacitor is shorted and this is a quick check on this likelihood. This is not always so, however, with this series. The point is this. The line output stage is fed through the efficiency diode. If the supply to this is broken (by removal of the top cap) there should be no sign of life in the line output stage except for the screen feed resistor getting hot. If there is plenty of life when the top cap of the diode is removed the h.t. must be getting through some other path. Usually a shorted boost reservoir capacitor provides this path and replacement clears up the whole fault. If there is no difference when the PY800 top cap is removed—except that the PL500 cools off—replace the PY800 itself as it may be faulty.

So now we come to the bitter bit. There is another possible path. It will be seen that the h.t. winding of the line output transformer at g is coupled through the reservoir capacitor C415 to winding h. If the capacitor is not shorted the nasty alternative is that the windings are. Now unfortunately this is not a "possible alternative". It is a highly probable one. In fact in this series of receivers it is the transformer which is likely to be at fault rather than the capacitor due to a weakness in the insulation between the windings. Replacement transformers are modified and the trouble should not recur but at the moment of writing the supply position is not good and a long delay is being experienced due to the very large number on order. If the transformer can be obtained there is no trouble in fitting it. The unit is supplied complete and can be connected in a few moments. It is a two-screw fitting with flylead plugs.

Width Circuit Resistors

Having said all that I can hear several voices shouting "what about the resistors then?" Yes, well we're coming to that. On the lower right side of the timebase panel just above the 625-line width stabilising preset R423 there are two resistors (R457 and R427) both having a value of $8.2M\Omega$ (or $8M2$, have it as you will). These invariably change value (going high). As they increase in value the width is reduced appearing first as a gap down either side then as the drive is further reduced the e.h.t. regulation is impaired so that advancing the brilliance will cause a narrow picture to expand and defocus before disappearing altogether. The drill is to check the value of these resistors as a routine matter and replace with high-stability types. Then go on to check the valves and circuit in the normal way.

So there it is, the weak links are the capacitor across the tube base socket, the boost reservoir capacitor, the transformer, the resistors R427 and R457 and of course the valves.

CONTINUED NEXT MONTH

USING THE OSCILLOSCOPE

—continued from page 326

amplitude of the signal at the output of the circuit under test is measured by a detector diode, either that used in the circuit itself or one added for the purpose. The X-timebase waveform sweeps the frequency of the oscillator (wobbulator) across the frequency range appropriate to the circuit under test and the output signal displayed on the oscilloscope is a trace of amplitude plotted against frequency.

Thus the wobbulator enables us to carry out another kind of measurement with the oscilloscope. A signal generator can be used to provide markers which indicate frequencies on the trace. If a small signal from the generator is introduced into the circuit under test—along with the signal from the wobbulator—a beat will be produced as the wobbulator sweeps through the generator frequency. This beat appears as a pip on the trace so that calibration and frequency measurement are possible.

It will be realised that the scope timebase speed can be adjusted over a wide range without upsetting the trace displayed. It is however best to avoid extremely fast or slow timebase speeds. In the first case the detector diode circuit will not be able to respond fast enough, while in the second the coupling from the scope to the wobbulator may cause non-linearity. In either case the trace displayed will not be an accurate portrayal of the response curve. It will be found in practice that the response curve shape will remain substantially constant over a fairly wide frequency range. Usually a sweep frequency of 50 to 100Hz is most satisfactory since this rate is least affected by the factors mentioned above.

A last scope and wobbulator set up is shown in Fig. 11.

Conclusion

It has been the purpose of these two articles to provide a treatment from first principles of the oscilloscope in terms of its function, working and basic application. The reader who has appreciated the flexibility of the oscilloscope as a test instrument will realise that numerous applications exist which are very time saving. A complete list is formidable but the following are useful in television servicing: checking timebase waveforms, sync signals, video levels, assessment of simultaneous a.c. and d.c. levels and observing audio waveforms to name a few. It is also appropriate to mention how useful a scope can be in examining bias and erase waveforms in tape recorders, the double-beam scope being ideal for stereo!

Confidence in the use of the oscilloscope is a prerequisite of its efficient application. As with all things confidence and proficiency are only acquired by practice, and learning to "drive" an oscilloscope is no exception. To begin with one should try using the oscilloscope to observe normal conditions in equipment which is operating satisfactorily. This has the double advantage that one learns what to expect to see as well as knowing that the signal is there to be seen—if you don't see it you are doing something wrong!

A competent engineer should reach out as naturally for the oscilloscope as for his Avo meter, using it confidently as the situation demands. ■

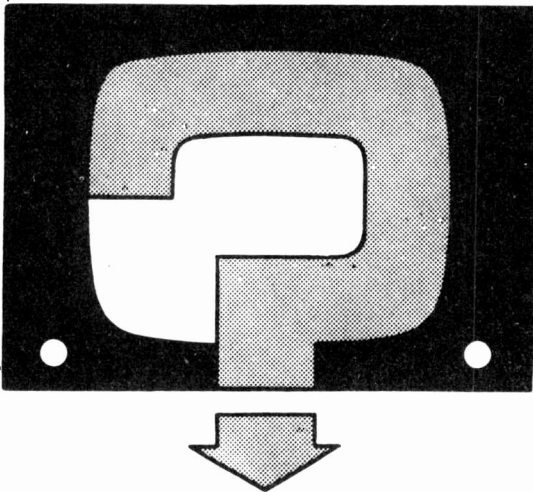

YOUR PROBLEMS SOLVED

★ Requests for advice in dealing with servicing problems must be accompanied by a 10p. postal order (made out to IPC Magazines Ltd.) the query coupon from page 331 and a stamped, addressed envelope. We can deal with only one query at a time. We regret that we cannot supply service sheets or answer queries over the telephone.

BUSH TV118

There is picture cramping at each side of the top half of the picture. The PL36 and a number of other valves have been replaced. The line hold is very sensitive when the set is first switched on and inclined to move the picture from side to side on adjustment.—E. Carter (Preston).

A picture which is wedge shaped, narrowing in width towards the top, suggests that the scan coils are at fault. First however ensure that the coils are pushed well up to the bulb of the tube. The critical line hold may be due to faulty flywheel sync discriminator diodes and these should be checked.

PHILIPS 19TG156A

The sound comes on normally but the picture takes five minutes to appear and then shrinks gradually to give a picture of reduced size with poor contrast. The contrast and brightness controls have to be set fully anti-clockwise before a picture can be obtained and if either of these controls is turned up even slightly the picture expands and disappears. There is a good signal and the fault is present on both systems.—F. Round (Coventry).

Check the PL36 and PY800 valves in the line time-base (inside the screened section): replacement of one or both of these valves should restore normal scanning. It may also be necessary to replace the PL83 video amplifier valve in order to obtain reasonable contrast.

GEC 2028

This colour set has been in operation for almost three years. The width is slowly decreasing, with a $\frac{1}{2}$ in. gap at each side of the screen at present—everything else is OK. The deflection coils are almost at the back of their slider on the tube neck—K. Lowndes (Barnet).

From the progressive nature of the trouble there appears to be a definite component fault the most likely being a slowly dying line output valve (V11, PL509). This should be checked. It is however fairly common on the early versions of this model for the line output transformer to give rise to various problems and this should be borne in mind. Also check the width stabilising v.d.r. (VDR701 E298ZZ/05). Small errors in width on this model can be taken up using the line linearity control.

HMV 1870

The trouble is poor field and line hold. The controls can be set (just) for a steady picture but if the contrast or brilliance controls are advanced the line hold goes haywire with picture rolling. If these controls are turned down again the picture will just lock. The set has to be operated with the contrast control turned down.—P. Dixon (Bristol).

This sort of trouble is usually caused by a faulty sync separator or video valve (V6 PCF80 and V5 PCL84) and these valves should be checked. Also check the h.t. voltage at the cathode (pin 8) of the PY32 h.t. rectifier where a reading of 207V should be obtained. If low, check the mains tapping position in use, the rectifier valve and the dropper resistors R124 and R125.

PYE 62

The picture has begun to shrink on both sides by about an inch, increasing gradually. Sometimes the raster enlarges to a blank screen. The contrast and brilliance controls have no effect other than to produce ballooning to a blank screen.—R. Green (Leeds).

These are the symptoms of an unregulated e.h.t. supply. This is usually caused by a faulty e.h.t. rectifier (DY802). If, however, this valve is all right it is possible though less likely that the PL504 or PY800 may be faulty. If all these valves are in order the line output transformer may need replacement.

FERGUSON 406

There are 14 dark and light bars from the top to the bottom of the screen. They are not too disturbing on light pictures but on a dark picture they show up at the same density as the received picture. The trouble is present on all channels.—J. Brown (Chelmsford).

The vertical striations are caused by harmonic ringing in the line output stage. It is possible that this could be due to a change in value of one of the capacitors associated with the line output transformer but it is more probable that the transformer itself or the scan coils are at fault. Unfortunately the only sure way of testing either of these components is by replacement.

EKCO T368F

The whites become black and the blacks white although the sound is OK. The fault can be cleared by decreasing the contrast or brightness control settings but the picture is then too poor to view.—J. Dolby (Maidstone).

The fact that the fault can be cured by both the brightness and contrast controls suggests that the c.r.t. is faulty. However the vision detector diode should be checked first. This is in the top half of the final vision i.f. transformer.

FERGUSON 3627

There is good sound but no picture. The v.d.r. Z3 in the width stabilisation circuit overheats but cools down when the cap of the PY801 efficiency diode is removed. The line output stage valves have been replaced. The raster is present but very faint.—A. Dobson (Malmsbury).

Replace the 100pF high-voltage tubular ceramic capacitor C106 which feeds pulses from the line output transformer to the v.d.r. Z3.

PYE V220

The field scan has failed completely. The PCL82 and the coupling capacitors in the timebase have been changed and the blocking oscillator transformer checked for continuity.—T. Johnson (Halifax).

Isolate the fault to the oscillator or output sections of the field timebase. An oscilloscope will tell you instantly, but without one the quickest test is to apply 6V a.c. to the grid of the output pentode. This should produce a reduced field scan if the output

stage is working. If it is not working follow up with voltage tests.

BUSH TV53

The fault—the whites pulling on both channels 1 and 8—developed very quickly. This occurs only on scene highlights but is affected by both the brightness and contrast controls. If the picture is adjusted to provide normal quality, whites such as faces go negative. The video amplifier, video detector and the valves in the line timebase have been replaced.—K. Hall (Gainsborough).

Check whether the tube is dropping the correct voltage across heater pins 1 and 12. This should be approximately 6.3V. If you check this you may find that something like half this voltage is being developed denoting a partial short in the tube's heater element. A sharp tap on the neck of the tube in the vicinity of the ion trap magnet could temporarily remove the short and produce normal conditions.

HMV 1921 Phase 2

I have recently converted this set for dual-standard operation and the conversion has been most successful. There is however slight shrinkage of the picture on switching from 405 to 625—the picture is then about 1 in. from the left-hand side of the screen.—K. Rolston (Bury).

It is essential for the PL36 and PY81 valves to be in good condition for full width to be obtained on 625 lines and in view of the age of the set these should be replaced. Also check the resistors in the width control circuit. There should be a slight over-scan on 405.

STEPHENS		ELECTRONICS, P.O. BOX 26, AYLESBURY, BUCKS		SEND S.A.E. FOR LISTS GUARANTEE Satisfaction or money refunded	
SEMI-CONDUCTORS · BRAND NEW · MANUFACTURERS MARKINGS · NO REMARKED DEVICES					
2N3984A	62p	2N1631	42p	2N2614	30p
2N404	22p	2N2642	42p	2N2646	57p
2N696	20p	2N1637	42p	2N2696	32p
2N697	20p	2N1638	37p	2N2711	30p
2N698	20p	2N1639	37p	2N2712	30p
2N699	62p	2N1701	1.62p	2N2713	27p
2N706	18p	2N1711	22p	2N2714	30p
2N707A	82p	2N1864	32p	2N2825	62p
2N709	15p	2N1893	42p	2N2904	35p
2N718A	25p	2N2147	72p	2N2904A	40p
2N719A	30p	2N2198	62p	2N2905	40p
2N726	30p	2N2199	47p	2N2905A	45p
2N727	30p	2N2199A	50p	2N3414	27p
2N914	17p	2N2195	22p	2N3415	27p
2N916	17p	2N2217	27p	2N3416	37p
2N918	30p	2N2218	32p	2N3439	1.30p
2N929	22p	2N2219	32p	2N3440	97p
2N930	27p	2N2220	22p	2N3449	87p
2N957	52p	2N2221	25p	2N3450	87p
2N1131	27p	2N2222	30p	2N3451	87p
2N1132	32p	2N2247	1.07p	2N3452	87p
2N1302	17p	2N2297	30p	2N3453	87p
2N1303	17p	2N2298	17p	2N3454	87p
2N1304	22p	2N2299	17p	2N3455	87p
2N1305	22p	2N2369A	20p	2N3456	87p
2N1306	22p	2N2410	42p	2N3457	87p
2N1307	25p	2N2483	27p	2N3458	25p
2N1308	30p	2N2484	32p	2N3459	27p
2N1309	30p	2N2559	22p	2N3460	30p
2N1507	27p	2N2540	22p	2N3461	30p
2N1613	25p	2N2613	35p	2N3462	30p
DIODES & RECTIFIERS					
1N461	10p	AA119	10p	BY100	22p
1N474	7p	AA129	10p	BY103	22p
1N4916	22p	AAZ13	10p	BY122	37p
18010	15p	AA114	12p	BY124	30p
18021	20p	AA107	18p	BY126	20p
18025	25p	BA102	22p	BY127	22p
1844	10p	BA110	32p	BY128	22p
18113	15p	BA115	71p	BY211	32p
18120	15p	BA114	12p	BY212	30p
18121	17p	BAX13	12p	BYZ13	25p
18130	12p	BAX16	12p	BZ788	0A91
18131	12p	BYA18	17p	(Series)	32p
18132	15p	BYA31	71p	FRT3/4	22p
18940	71p	BYA38	12p	FRT3/5	30p
2N3349	1.30p	2N3399	37p	2N3710	20p
2N3399	37p	2N3401	20p	2N3711	20p
2N3401	20p	2N3402	20p	2N3712	1.50p
2N3402	20p	2N3403	20p	2N3713	1.50p
2N3403	20p	2N3404	20p	2N3714	1.75p
2N3404	20p	2N3405	20p	2N3715	52p
2N3405	20p	2N3406	20p	2N3716	45p
2N3406	20p	2N3407	20p	2N3717	45p
2N3407	20p	2N3408	20p	2N3718	45p
2N3408	20p	2N3409	20p	2N3719	45p
2N3409	20p	2N3410	20p	2N3720	45p
2N3410	20p	2N3411	20p	2N3721	45p
2N3411	20p	2N3412	20p	2N3722	45p
2N3412	20p	2N3413	20p	2N3723	45p
2N3413	20p	2N3414	20p	2N3724	45p
2N3414	20p	2N3415	20p	2N3725	45p
2N3415	20p	2N3416	20p	2N3726	45p
2N3416	20p	2N3417	20p	2N3727	45p
2N3417	20p	2N3418	20p	2N3728	45p
2N3418	20p	2N3419	20p	2N3729	45p
2N3419	20p	2N3420	20p	2N3730	45p
2N3420	20p	2N3421	20p	2N3731	45p
2N3421	20p	2N3422	20p	2N3732	45p
2N3422	20p	2N3423	20p	2N3733	45p
2N3423	20p	2N3424	20p	2N3734	45p
2N3424	20p	2N3425	20p	2N3735	45p
2N3425	20p	2N3426	20p	2N3736	45p
2N3426	20p	2N3427	20p	2N3737	45p
2N3427	20p	2N3428	20p	2N3738	45p
2N3428	20p	2N3429	20p	2N3739	45p
2N3429	20p	2N3430	20p	2N3740	45p
2N3430	20p	2N3431	20p	2N3741	45p
2N3431	20p	2N3432	20p	2N3742	45p
2N3432	20p	2N3433	20p	2N3743	45p
2N3433	20p	2N3434	20p	2N3744	45p
2N3434	20p	2N3435	20p	2N3745	45p
2N3435	20p	2N3436	20p	2N3746	45p
2N3436	20p	2N3437	20p	2N3747	45p
2N3437	20p	2N3438	20p	2N3748	45p
2N3438	20p	2N3439	20p	2N3749	45p
2N3439	20p	2N3440	20p	2N3750	45p
2N3440	20p	2N3441	20p	2N3751	45p
2N3441	20p	2N3442	20p	2N3752	45p
2N3442	20p	2N3443	20p	2N3753	45p
2N3443	20p	2N3444	20p	2N3754	45p
2N3444	20p	2N3445	20p	2N3755	45p
2N3445	20p	2N3446	20p	2N3756	45p
2N3446	20p	2N3447	20p	2N3757	45p
2N3447	20p	2N3448	20p	2N3758	45p
2N3448	20p	2N3449	20p	2N3759	45p
2N3449	20p	2N3450	20p	2N3760	45p
2N3450	20p	2N3451	20p	2N3761	45p
2N3451	20p	2N3452	20p	2N3762	45p
2N3452	20p	2N3453	20p	2N3763	45p
2N3453	20p	2N3454	20p	2N3764	45p
2N3454	20p	2N3455	20p	2N3765	45p
2N3455	20p	2N3456	20p	2N3766	45p
2N3456	20p	2N3457	20p	2N3767	45p
2N3457	20p	2N3458	20p	2N3768	45p
2N3458	20p	2N3459	20p	2N3769	45p
2N3459	20p	2N3460	20p	2N3770	45p
2N3460	20p	2N3461	20p	2N3771	45p
2N3461	20p	2N3462	20p	2N3772	45p
2N3462	20p	2N3463	20p	2N3773	45p
2N3463	20p	2N3464	20p	2N3774	45p
2N3464	20p	2N3465	20p	2N3775	45p
2N3465	20p	2N3466	20p	2N3776	45p
2N3466	20p	2N3467	20p	2N3777	45p
2N3467	20p	2N3468	20p	2N3778	45p
2N3468	20p	2N3469	20p	2N3779	45p
2N3469	20p	2N3470	20p	2N3780	45p
2N3470	20p	2N3471	20p	2N3781	45p
2N3471	20p	2N3472	20p	2N3782	45p
2N3472	20p	2N3473	20p	2N3783	45p
2N3473	20p	2N3474	20p	2N3784	45p
2N3474	20p	2N3475	20p	2N3785	45p
2N3475	20p	2N3476	20p	2N3786	45p
2N3476	20p	2N3477	20p	2N3787	45p
2N3477	20p	2N3478	20p	2N3788	45p
2N3478	20p	2N3479	20p	2N3789	45p
2N3479	20p	2N3480	20p	2N3790	45p
2N3480	20p	2N3481	20p	2N3791	45p
2N3481	20p	2N3482	20p	2N3792	45p
2N3482	20p	2N3483	20p	2N3793	45p
2N3483	20p	2N3484	20p	2N3794	45p
2N3484	20p	2N3485	20p	2N3795	45p
2N3485	20p	2N3486	20p	2N3796	45p
2N3486	20p	2N3487	20p	2N3797	45p
2N3487	20p	2N3488	20p	2N3798	45p
2N3488	20p	2N3489	20p	2N3799	45p
2N3489	20p	2N3490	20p	2N3800	45p
2N3490	20p	2N3491	20p	2N3801	45p
2N3491	20p	2N3492	20p	2N3802	45p
2N3492	20p	2N3493	20p	2N3803	45p
2N3493	20p	2N3494	20p	2N3804	45p
2N3494	20p	2N3495	20p	2N3805	45p
2N3495	20p	2N3496	20p	2N3806	45p
2N3496	20p	2N3497	20p	2N3807	45p
2N3497	20p	2N3498	20p	2N3808	45p
2N3498	20p	2N3499	20p	2N3809	45p
2N3499	20p	2N3500	20p	2N3810	45p
2N3500	20p	2N3501	20p	2N3811	45p
2N3501	20p	2N3502	20p	2N3812	45p
2N3502	20p	2N3503	20p	2N3813	45p
2N3503	20p	2N3504	20p	2N3814	45p
2N3504	20p	2N3505	20p	2N3815	45p
2N3505	20p	2N3506	20p	2N3816	45p
2N3506	20p	2N3507	20p	2N3817	45p
2N3507	20p	2N3508	20p	2N3818	45p
2N3508	20p	2N3509	20p	2N3819	45p
2N3509	20p	2N3510	20p	2N3820	45p
2N3510	20p	2N3511	20p	2N3821	45p
2N3511	20p	2N3512	20p	2N3822	45p
2N3512	20p	2N3513	20p	2N3823	45p
2N3513	20p	2N3514	20p	2N3824	45p
2N3514	20p	2N3515	20p	2N3825	45p
2N3515	20p	2N3516	20p	2N3826	45p
2N3516	20p	2N3517	20p	2N3827	45p
2N3517	20p	2N3518	20p	2N3828	45p
2N3518	20p	2N3519	20p	2N3829	45p

GEC 2041

The reception on this colour set is normally perfect but occasionally—especially noticeable on darker scenes—there are mauve and green bands travelling sometimes downwards and at others upwards. The bands are about 1in. in width and also appear on a black-and-white picture when the colour control is turned down.—G. Richards (Bury).

The moving pattern on the screen is almost certainly hum bars. These could be caused by ripple on the h.t. line and the smoothing and reservoir capacitors should be checked by bridging with known good ones. However because of the degree of colour change on the colour pictures it seems more likely that there is a heater-cathode short in one of the valves.

PYE 12L

The picture height keeps changing. It starts off at full amplitude then the height alters—equally at top and bottom—and then reverts to full amplitude again. The picture is steady and locks well. The boost voltage is normal at full height but falls by about 50V when the height decreases—the c.r.t. first anode voltage also falling. The height jumps from full to about half and back again.—G. Thomson (Oxford).

The trouble could be due to a dry-joint which a disturbance test around the height and hold controls could reveal. Check also for good connections to the thermistor embedded in the scan coils.

BUSH TV66

There is no raster at all although the sound is OK. The e.h.t. seems to be there all right as there is a good spark at the final anode of the tube. A switch-

off spot appears shortly after the set is switched off.—P. Morton (Salisbury).

The fault is in the first anode supply to pin 10 of the tube base. This point is supplied via a 100k Ω resistor under the timebase chassis about three-quarters of the way along the tagstrip towards the PCL83 (controls) end. This resistor is decoupled by an electrolytic capacitor under the panel. Cut this out and wire in an 0.5 μ F (or 0.47 μ F) capacitor rated at 500V or more from the resistor to chassis.

PAM 5112

I have only recently tried to get BBC-2 on this set. An aerial has been fixed up and although there is quite a good picture the sound is accompanied by a continuous hum on the station which makes viewing impossible. The valves have been replaced with no difference.—D. Fox (Scarborough).

You will have to realign the coil cores on the lower left side of the main panel. Of the three coil cans only the upper of the two on the extreme left should be adjusted (the lower one is for 405 only). The most critical adjustment is that to the core of L28 just below the EH90. The other cores requiring adjustment are T2 A and B.

QUERIES COUPON

This coupon is available until May 22, 1971, and must accompany all Queries sent in accordance with the notice on page 329. Don't forget the 10p postal order!

TELEVISION, MAY, 1971

TEST CASE



101

Each month we provide an interesting case of television servicing to exercise your ingenuity. These are not trick questions but are based on actual practical faults.

? A Pye Model V200 came in with the very unusual symptom of the picture height altering as the brightness control was adjusted! On test the set performed correctly for a couple of hours after which the height suddenly collapsed by about half with a slight reduction in brightness and focus. This fault condition then made it possible to adjust the height with the brightness control.

It was a bit of a job to know just where to start in the examination of a curious symptom like this. The field generator and amplifier appeared to be working correctly. The valves were tested and substituted but

the intermittent condition remained, the set having to run for an hour or more before the field amplitude reduced and came under the influence of the brightness control.

What if any is a possible connection between the field amplitude and the brightness control? See next month's TELEVISION for the solution to this intriguing fault and for a further item in the Test Case series.

SOLUTION TO TEST CASE 100

Page 282 (last month)

The boosted h.t. supply feeds not only the field timebase generator but also the first anode of the picture tube and it was eventually found that the voltage rose from the abnormally low voltage of 250V to the correct 480V when the boosted h.t. supply connection to the tube first anode was removed.

The fault was thus caused by a picture tube defect, the first anode for some reason or other putting a heavy load on the high-impedance boost supply. To avoid replacing the tube the first anode was energised from a separate low-impedance supply obtained via a small rectifier and reservoir capacitor from the power input. The correct 480V could not be obtained in this way of course but the lower voltage merely had the effect of reducing slightly the focus of the picture.

TELEVISION CLASSIFIED ADVERTISEMENTS

The pre-paid rate for classified advertisements is 4p a word (minimum 12 words), box number 7½p extra. Semi-display setting £2.50 per single column inch. All cheques, postal orders, etc., to be made payable to TELEVISION and crossed "Lloyds Bank Ltd." Treasury notes should always be sent *registered post*. Advertisements, together with remittance, should be sent to the Classified Advertisement Manager, TELEVISION IPC Magazines Ltd., Fleetway House, Farringdon Street, London, EC4A 4AD, for insertion in the next available issue.

EDUCATIONAL

TRAIN FOR SUCCESS WITH ICS

Study at home for a progressive post in Radio, TV and Electronics. Expert tuition for City & Guilds (Telecoms Techn's Cert. and Radio Amateurs') R.T.E.B., etc. Many non-exam courses incl. Colour TV Servicing, Numerical control & Computers. Also self-build kit courses—valve and transistor.

Write for **FREE prospectus** and find out how ICS can help you in your career.

ICS, DEPT. 560, INTERTEXT HOUSE, STEWARTS ROAD, LONDON S.W.8.

ENGINEERS—get a technical certificate. Exam and Certificate Postal Courses in all branches of Engineering, Electronics, Radio and TV, Computers, Draughts, Building, etc. Write for helpful **FREE BOOK: BIET (Dept. 171K)**, Aldermaston Court, Reading, RG7 4PF.

BECOME "Technically Qualified" in your spare time, guaranteed certificate and exam Home Study courses in Radio, TV, servicing and maintenance, R.T.E.B., City & Guilds, etc., highly informative **FREE Guide**.—Chambers College (Dept. 858K), Aldermaston Court, Reading, RG7 4PF.

RADIO AND TV Exams and Courses by Britain's finest home study School, Coaching for Brit.I.R.E., City and Guilds Amateur's Licence, R.T.E.B., P.M.G. Certificate, etc. Free brochure from British National Radio School, Russel Street, Reading.

MEN! You can earn £50 p.w. Learn Computer Operating. Send for **FREE brochure**—London Computer Operators Training Centre, C98 Oxford House, 9-15 Oxford Street, London, W.1.

LADDERS

VARNISHED TIMBER LADDERS from manufacturer, **LOWEST PRICES** anywhere: 15½ ft ext. £6.20; 17 ft ext. £6.50; 20 ft ext. £7; 21½ ft ext. £7.75; 24½ ft ext. £8.90; 29 ft ext. £10.25; 31½ ft triple ext. £12.25; 36 ft triple ext. £16. Carr. 80p. Free Lists. Also Aluminium Ext. and Loft Ladders. **CALLERS WELCOME.** Dept. PTT, HOME SALES, BALDWIN ROAD, STOURPORT, WORCS. Phone 02-993 2574. Placing order on C.O.D.

FOR SALE

625/405 VHF/UHF IF Panels. B.R.C. 850 series. Ideal for components, IF transformers and switching, P/C Valve bases or repairs to this Thorn receiver. £1.75 each plus 22½p p.p. **WILLOW VALE.** 4 The Broadway, Hanwell, W.7.

WANTED

TOP PRICES PAID
for new valves, popular
TV & Radio Types
KENSINGTON SUPPLIES
(A), 367 Kensington Street
Bradford 8, Yorks

CASH PAID for New Valves. Payment by return. **WILLOW VALE ELECTRONICS,** 4 The Broadway, Hanwell, London, W.7. 01-567 5400/2971.

SERVICE SHEETS purchased, **HAMILTON RADIO,** 54 London Road, Bexhill.

WANTED! New valves especially TV types. Cash waiting. Bearman, 6 Potters Road, New Barnet, Herts. Tel. 449/1934.

SERVICE SHEETS

TRADER SERVICE SHEETS

30p each plus postage

We can supply **Trader Service Sheets** for most makes and types of Radios, Tape Recorders and Televisions—Manuals for some.

Cheques and open P.O.s returned if sheets not available.

OAKFIELD ENTERPRISES

LIMITED
30 CRAVEN STREET, STRAND
LONDON WC2

Make	Model	Radio/TV

1971 List now available at 10p plus postage

If list is required indicate with X

From.....

Address.....

enclose remittance of.....

(and a stamped addressed envelope) s.a.e. with enquiries please
MAIL ORDER ONLY (May T)

RADIO, TELEVISION, over 3,000 models. **JOHN GILBERT TELEVISION,** 1b Shepherds Bush Road, London, W.6. **SHE 8441.**

SERVICE SHEETS (continued)

LARGE SUPPLIER of SERVICE SHEETS

(TV, RADIO, TAPE RECORDERS, RECORD PLAYERS, TRANSISTORS, STEREOGRAMS, RADIOGRAMS, CAR RADIOS)

Only 25p each. Manuals from 50p

PLEASE ENCLOSE LARGE S.A.E. WITH ALL ENQUIRIES AND ORDERS.

Otherwise cannot be attended to.

(Uncrossed P.O.'s please, original returned if service sheets not available.)

C. CARANNA 71 BEAUFORT PARK, LONDON, N.W.11

We have the largest supplies of **Service Sheets** (strictly by return of post). Please state make and model number alternative.

Free TV fault tracing chart or TV list on request with order.

MAIL ORDER ONLY

SERVICE SHEETS with Free Fault Finding Chart, 22½p. S.A.E. Lesmar, 15 Conholt Rd., Andover, Hants. (Mail only).

SERVICE SHEETS. Radio, TV, etc. 8,000 models. List 10p. S.A.E. enquiries. **TELRAY,** 11 Maudland Bank, Preston.

SERVICE SHEETS

(1925-1971) for Radios, Televisions, Transistors, Radiograms, Car Radios, Tape Recorders, Record Players, etc. By return post with

FREE FAULT FINDING GUIDE

PRICES FROM 5p

Over 8,000 models available. Catalogue 13p.

Please send stamped addressed envelope with all orders and enquiries.

Hamilton Radio

54 London Road, Bexhill, Sussex

SETS & COMPONENTS

EX N.E.V. C.C.T.V. Camera and Monitor Circuits, S.A.E. for list. **LOWE,** 29 Vanner Point, Hackney, London, E.9. **5AX.**

SETS & COMPONENTS (continued)

NEW BVA VALVES! Huge range by return postal service well known to the trade. Brief list of television types herewith, full list S.A.E. All types ex stock!

DY86/7	40p	PCF86	61p	PY82	35p	20L1	97p
EB91	25p	PCF801/2	61p	PY800/1	45p	20P4	£1-00
ECC82	42p	PCF805	65p	R19	65p	30C15	69p
ECL80	40p	PCF808	67p	U25	75p	30C17	79p
EF80	40p	PCL82	51p	U26	75p	30F5	82p
EF85	41p	PCL83	61p	U37	75p	30FL1/2	64p
EF183/4	56p	PCL84	51p	U191	72p	30L15	76p
EH90	51p	PCL805/85	57p	U193	41p	30L17	72p
EY51	37p	PCL86	51p	U251	87p	30P12	77p
EY86/7	39p	PL36/8	75p	U301	85p	30PL1	64p
PC86/8	51p	PL81	57p	U801	£1-20	30P4MR	£1-00
PC97	41p	PL83	51p	6/30L2	77p	30P19	75p
PC900	51p	PL84	60p	6AT6	49p	30PL13	92p
PCC84	46p	PL500	85p	6BW7	69p	30PL14/5	92p
PCC89	61p	PL504	85p	6CD6G	£1-40		
PCF80	51p	PY81	45p	6F23	77p	etc.	Trade prices

POST FREE OVER £3-00

LATEST BY100/127 type and 33 ohm 10 watt res, 20p NEW

Large bulb imported PCF80 32p! **Note.** Ask for separate components lists.

LOOK! Nearly every type in stock now!!

NEW TELEVISION TUBES!

TWO YEAR FULL REPLACEMENT GUARANTEE

SEE THE DIFFERENCE A NEW TUBE CAN MAKE TO YOUR VIEWING—LATEST SCREENING TECHNIQUES INCLUDING TINTED SCREENS ON MOST 19" and 23" TYPES

Large stocks by Cathodeon and other leading manufacturers so why buy ordinary rebuilds?

COLOUR. 19" £40-00; 22" £45-00; 25" £48-00

Special offer! 19" mono rebuilds, 2 year guarantee £5-50! 23" £7-50

12" £3-00 (not 110°) 20" Mullard. 14" to 16" (not 110°) £4-75

17" £5-87 A50/120W £10-50

19" mono tubes—all £6-87. Carriage all 60p. All 21" mono tubes—£7-87

23" mono tubes £9-50. Carriage 75p also 24" and 25" available.

RIMBANDS, 19" £8-50; 23" £11-50

Carriage

TWIN PANELS, 19" £10-12; 23" £15-00

£1-00

Bulk enquiries welcomed, special terms

PAY BY GIRO. Our No. 34.361.4006.

PHILIP H. BEARMAN

(Suppliers to H.M. Govt. etc.)

6 POTTERS ROAD, NEW BARNET, HERTS.

Closed Thurs & Sat afternoons

TEL. 01-449/1934 & 1935

(Robophone)

R & R RADIO

51 Burnley Road, Rawtenstall

Rossendale, Lancs

Tel.: Rossendale 3152

TESTED VALVES—
3 MONTHS' GUARANTEE

EBF80	15p	PCC84	15p	PY800	171p
EBF89	171p	PCF80	15p	PY801	171p
ECC82	15p	PCL82	20p	U191	221p
ECL80	15p	PL36	25p	30C15	25p
EF80	10p	PY33	25p	PCF86	25p
EF85	15p	PY81	171p	PCL85	25p
EY86	20p	PY82	15p	PCL84	25p

Copper Laminate Board, for etching, 1p per sq.in. Double sided 11p per sq.in. Any size cut, min. order 50p plus 10% P. & P.

Postage on Valves: one valve 4p, up to 6 21p, over 6 post paid.

SPARES

available from second-hand TVs. Transformers, Valves, etc. S.A.E. your enquiries. Complete 19-in. TVs, untested, from £5 plus £1-50 carriage.

LINAVALE RADIO LTD.,

48 Hoe St., London, E.17.

01-520-7546.

150 NEW ASSORTED Capacitors, Resistors, Silvered Mica, Ceramic, etc. Carbon, Hystab, Vitreous 4-20 watt, 75p. Post Free. WHITSAM ELECTRICAL, 33 Drayton Green Road, West Ealing, London, W.13.

TELEVISION SPARES. All makes and models, new and used. Send S.A.E. for your enquiries. Used Tested Valves 20p each, postage 21p. Thriftys, Green Lane Farm, Green Lane, Chessington, Surrey.

TELEVISION TUBE SHOP

BRAND NEW TUBES AT
REDUCED PRICES

A28-14W (A28-13W)	£11-75
A31-18W	£12-50
A47-11W	£9-95
A47-13W	£12-50
A47-14W	£7-75
A47-26W	£10-75
A50-120WR	£12-50
A59-11W	£12-95
A59-13W	£13-50*
A59-15W	£9-95
A59-16W	£13-50*
A59-23W	£14-75
A61-120WR	£16-00
AW21-11	£10-50†
AW36-20	£5-75
AW36-80	£5-75
AW43-80	£6-50
AW43-88, 43-89	£6-75
AW47-90, 47-91	£7-50
AW53-80	£7-50*
AW53-88, 53-89	£8-25
AW59-90, 59-91	£9-00
C17LM, 17PM, 17SM	£6-50
CME1101	£12-00
CME1201	£12-50
CME1402	£5-75
CME1601	£10-50
CME1602	£12-00
CME1702, 1703	£6-75
CME1705	£7-75
CME1901, 1903	£7-50
CME1906	£12-50
CME1908	£7-75
CME2013	£12-50
CME2101, 2104	£8-25
CME2301, 2302	£9-00
CME2305	£14-75
CME2306	£13-50*
CME2308	£9-95
CME2413R	£16-50
CRM93	£5-50*
CRM124	£5-50
CRM141, CRM142	£5-50
CRM171, CRM172	£6-50
CRM211, CRM212	£7-50*
MW36-24, 36-44	£5-50
MW43-69	£6-75
MW43-80	£6-75
MW53-20, 53-80	£7-5*
TSD217, TSD282	£14-00†
13BP4 (Crystal 13)	£14-00†

†Rebuilt tubes also, at £7-00

*These types are FULLY rebuilt.

ALL TUBES ARE TESTED AND GUARANTEED FOR A MINIMUM OF 12 MONTHS

ADD 75p FOR CARRIAGE AND INSURANCE

COLOUR TUBES

19 in. and 22 in. having slight marks or scratches at £35 each.

TELEVISION TUBE SHOP

48 BATTERSEA BRIDGE ROAD,
LONDON, S.W.11. BAT 6859

WE GIVE GREEN SHIELD
STAMPS

T.V. SPARES

OIL FILLED MURPHY LOPT's U26 type. Model number not known. £1.25 each plus 25p p.p.

BAIRD FERGUSON V.H.F. TUNERS. Uses PC97 and 30C18 valves. Fits 620 to 650 series models, complete with all coils, supplied less valves, £1.75 each plus 25p p.p.

BRC800 850 SERIES TIME BASE PANELS. Complete and unused in maker's unopened cartons £2.25 each plus 25p p.p.

FERGUSON/EKCO PLUG IN MAINS LEADS. Moulded two-pin connector type. 6 for £2.50 plus 25p p.p.

LATE G.E.C./SOBELL 625 405, etc. Dual Standard 405/625 I.F. Panels, complete with switching for direct replacement in this popular Radio and Allied receiver. £1.75 plus 25p p.p. Fits all 1000 and 2000 series.

LINE TIMEBASE PANELS for above series, complete and for direct replacement, £1.75 plus 25p p.p.

TIMEBASE PANELS to fit Sobell 195, 282, 283, 284, 285, 286, 287, 288 (and DS models), McMichael MT762, 763, 765, 9405. Complete and new for direct replacement, £1.75 each plus 25p p.p.

V.H.F. ROTARY TUNER UNITS to fit McMichael, Sobell, G.E.C. 1000 series. New and unused, £1.75 each plus 25p p.p.

MULLARD COLOUR SCAN COILS. Complete with plug in leads. £3.50 each plus 25p p.p.

FERGUSON 800/850 series TIMEBASE PANELS complete and unused in original packing. £2.25 each, plus 25p p.p.

Terms. Cash with order or C.O.D. 27p extra. S.A.E. all enquiries. Catalogue of valves, CRT's, LOPT's, components, etc., 20p.

WILLOW VALE ELECTRONICS LTD.

4 & 5 The Broadway
Hanwell, London, W.7

Tel: 01-567 2971 and 5400
01-579 3582

Terms cash with order or C.O.D. 27p extra
S.A.E. all enquiries. Catalogue 20p

VALVES, VALVES, VALVES

Any ten of your choice 72½p, post 5p.
100 £5.50, post paid.

EF85, EF80, EB91, EBF89, ECL80, EF183, EY86, PCF80, PCC84, PL36, PY81, PCL82, PCL83, PCC89, PY33, PY82, PY800, PY801, PY88, PCL84, 30F5, 6BW7, PY801.

BOB'S,

2 St. James Street, Rawtenstall
Rossendale, Lancs.
Mail order ONLY.

SOUTHERN VALVE COMPANY (valve specialists)

44 Earls Court Road, London, W.8

ALL valves boxed and brand new, some BVA!

DY87 37p	PC86/8 50p	PCL805 45p	U193 35p	30L17 72p
DY802 45p	PC97 40p	PCL86 37p	U251 62p	30P12 62p
EB91 15p	PCF80 32p	PL36 52p	6/30L2 57p	30PL1 62p
ECC81 37p	PCF86 52p	PL81 45p	6BW7 50p	30P4MR 85p
ECC82 37p	PCF801 49p	PL84 50p	6CD6G 95p	30P19 70p
ECL80 37p	PCF802 49p	PL500/4 64p	6F23 67p	30PL13 80p
EF80 27p	PCF805 50p	PY81 45p	6F28 45p	30PL14 80p
EF183 37p	PCF808 62p	PY800 37p	20L1 95p	etc.
EF184 37p	PCL82 37p	PY801 37p	20P4 90p	NOTE
EH90 45p	PCL83 52p	U25 62p	30C15 60p	BY100/BY127
EY51 35p	PCL84 37p	U26 57p	30FL1/2 60p	equiv only 20p
EY86/7 37p	PCL85 45p	U191 62p	30L15 70p	with resistor.

Post free £2.00 and over. Mail order only.

[932

£5 TELEVISIONS £5

Delivered anywhere in Great Britain

17" 12 channel. Complete & tested. Good working order
Carriage and ins. £1

17" Untested TVs 12 channel. £1.50 Carriage £1. All makes

TUBES! TUBES!

Guaranteed 6 months

17" (43/88 only).....	£1.50
19" All makes.....	£2.00
23".....	£2.50
19" Bonded.....	£3.50
23" Bonded.....	£4.50

Plus 50p carriage

SPEAKERS FM 3 ohm perfect ex-T.V. (minimum order two) 5" round, 8" by 2" rectangular, 6" by 4" oval—12p each. Add 7p per speaker postage and packing.

VALVES EX EQUIPMENT

EB91 5p	EF184 12½p	PCF86 17½p	PCL86 17½p
EBF89 12½p	EY86 17½p	PC84 7p	PCL83 12½p
ECC82 12½p	30PL13 20p	PCF80 7p	PL36 22½p
ECL80 7p	630LZ 12½p	PCC89 12½p	PL81 17½p
EF80 12½p	30L15 12½p	PCL83 22½p	PY81 15p
EF85 12½p	30P4 12½p	PCL84 17½p	PY800 15p
EF183 12½p	PC97 17½p	PCL82 17½p	PY82 7p
PY33 22½p	U191 17½p	6F23 17½p	30PL1 22½p
30P12 20p	30F5 11p		

On two valves or more 5p postage & packing.

UHF TUNERS TO SUIT FERGUSON 850 900 CHASSIS
£2.50 p. & p. 50p

Dept. T.S.

THORNBURY TRADE DISPOSALS

Thornbury Roundabout, Leeds Rd., Bradford.
Tel. 665670

AERIAL BOOSTERS £2.95 EACH

We make four types of transistorized aerial pre-amplifiers. These take only seconds to install.

- L45 625 TELEVISION (U.H.F.).
- L12 405 TELEVISION (V.H.F.).
Please state channel numbers.
- L11 V.H.F. F.M. RADIO.
- L10 WIDEBAND RADIO.
This covers M/W and S/W to 20 MHz.

PRICE EACH

L45, L12 and L11 £2.95; L10 £1.95.

S.A.E. FOR DETAILS
MONEY BACK GUARANTEE
P. & P. 10p

VELCO ELECTRONICS

62 Bridge Street, Ramsbottom, Bury, Lancs. Tel. 3036

VALVE BARGAINS

Any 1—10p, 5—45p, 10—70p.

EB91, EBF89, ECC82, EY86, ECL80, EF80, EF85, EF183, EF184, PCC84, PCC89, PCC189, PC97, PCF80, PCF86, PCF800, PCL82, PC97, PCL84, PCL85, PL36, PL81, PL83, PY32, PY33, PY81, PY82, PY800, PY801, 30FL1, 30F5, 30L15, 30C15, 6F23, 6-30LZ.

TESTED, WITH 3 MONTH GUARANTEE VALVES
20p EACH

BY100 TYPE RECTIFIERS with Surge-resistor on bracket, 12½p each.

TOWERBY LTD

For Line Outputs and Deflector Coils

We have the Country's largest stock of Manufacturer's Original (or Authorised Replacement) Line Output Transformers for many "difficult" makes, including Ambassador, Baird, Cossor, Decca, Dynatron, Ekco, Ferguson, G.E.C., H.M.V., K.B., Masteradio, Pato-Scott, Philips, Ragentone, RGD, Sobell, Ultra, etc. Also deflector coils output and oscillator transformers, inc. Alba, Bush, Murphy, Examples, L.O.P.T. Murphy 350/410/540/659/759, £7.35; Bush, TV80, TV95, TV96, £7.35; Cossor 950, £3.87; Ferguson 306/308, £3.97; Philips 1768U L.O.P.T. assembly, £6.75; Ultra 1984-200c, £5.06. Rewind most L.O.P.T., £4.50.

SPECIAL OFFER

Ekco improved type for Models T221, 231, 310, all at £2.25; Ferranti 14T4 series inserts, £1.25; Philco 1019/1021, £2.62; Terms: C.W.O. or C.O.D. (17p), post-packing 30p; 2 or more L.O.P.T.s post-packing free. All enquiries answered but regret no lists available. Same day delivery on most types.

TOWERBY LTD

MAIL ORDER DIVISION OF T.C.S. LTD.
70 STREATHAM HILL, LONDON, SW2
Tel.: 01-674 2185.

NEW! Continuous range High-Gain Pre-Amplifier 40-900 mHz. Television, Radio, Stereo all bands including colour! Precision made in neat case. Fixed in seconds, no modifications, aerial connection only. Superb value at £7.75p. Post paid to anywhere in U.K. S.A.E. for Leaflet. Johnsons (Radio), St. Martin's Gate, Worcester.

WITWORTH TRANSFORMERS LTD.

Dept. P.T., 236 SANDYCOMBE ROAD.
RICHMOND.
SURREY.

Telephone: 01-940 8146. 9 a.m. till 5 p.m.

TELEVISION LINE OUTPUT TRANSFORMERS

PRACTICALLY ANY MAKE OR MODEL SUPPLIED OR REWOUND

EKCO, FERRANTI, DYNATRON Replacement cases £1.00 each, please state model.

S.A.E. for return of post quotation. TERMS: Cash with order or C.O.D., please add 20p for postage.

C.O.D. orders will be charged 30p extra. Transformers fully guaranteed. (98

AERIALS

AERIALS

UHF: Set Tops £2-10, Outside: 9 ele £1-25, 10 ele £1-90, 11 ele £2-50, 12 ele £2-55, 18 ele £3-25, 20 ele £3-50. Multi-beam 46 and Supremes £5-50.

All aerials supplied with clamps.

ANTIGHOST: Troubleshooters / Log-beams £5.

FM/VHF: H £2-25, 3 ele £3-25, 4 ele £3-75. Stereo 6 ele £6.

Motorized Units: Semi Auto £20, Auto £25.

All Aerials by either, "AERIALITE", J BEAM, ANTIFERANCE, PREMIER, MAXVIEW.

ACCESSORIES: Sockets, Plugs, Dips, Splitters, Masts, Lashings, etc., etc.

EAGLE PRODUCTS:

All that's best in Electronics: Head-phones, Amps, Speakers, Meters, etc. Send 25p for Catalogue.

COAXIAL: Standard 100 Mtrs. £4-50. Low Loss £7, or per Mtr.

State channels for all TV Aerials/Amps. FM state wide band or channelized.

TERMS: C.W.O., COD, P & P 3½p. Send 2½p stamps for lists. Callers Welcome.

JEFFRIES SERVICES

31 Hambrook St., Portsmouth, Tel. 28354

MAKING A TV PLAY

by
Cecil P. Taylor

A complete guide to concep-
tion, scripting, marketing
and production.

Price: £2-25 (Postage 15p)

From your bookseller or
direct from:

ORIEL PRESS LTD
32 Ridley Place
Newcastle upon Tyne
NE1 8LH

Please mention
TELEVISION
when replying to
ADVERTISEMENTS

Vary the strength
of your lighting with a
DIMMASWITCH

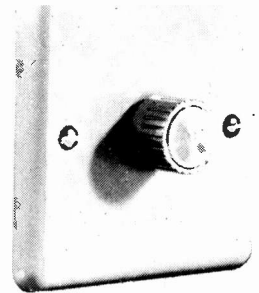

The DIMMASWITCH is an attractive and efficient dimmer unit which fits in place of the normal light switch and is connected up in exactly the same way. The ivory mounting plate of the DIMMASWITCH matches modern electric fittings. The bright chrome control knob activates an on-off switch and controls 40-600 watts of all lights except fluorescents at mains voltages from 200-250V, 50 Hz. The DIMMASWITCH has built-in radio interference suppression. Price: £3-20 plus 10p post and packing. Kit Form: £2-70 plus 10p post and packing. Please send C.W.O. to:-

DEXTER & COMPANY
3 ULVER HOUSE, 19 KING STREET,
CHESTER CH1 2AH. Tel: 0244-25883

As supplied to H.M. Government Departments,
Hospitals, Local Authorities, etc.

VALVES SAME DAY SERVICE
NEW! TESTED! GUARANTEED!

SETS 1R5, 1R5, 1T4, 3B4, 3V4, DAF91, DF91, DK91, DL92, DL94
Set of 4 for £1-02, DAF96, DF96, DK96, DL96, 4 for £1-45.

1A7GT -37	25L6GT -25	DL35 -25	EL90 -26	PCF808 -72	UAB80 -32
1H5GT -36	23U4GT -57	DL30 -28	EL900 -62	PCL82 -36	UAF42 -51
1NSGT -38	30C1 -30	DL94 -37	EM90 -41	PCL83 -60	UBC41 -52
1R5 -28	30C15 -63	DL96 -36	EM81 -41	PCL84 -37	UBF80 -34
1R5 -21	30C17 -80	DY86 -28	EM84 -33	PCL85 -45	UBF89 -36
1T4 -16	30C18 -67	DY87 -28	EM87 -37	PCL86 -41	UCC84 -35
3B4 -28	30F5 -76	EABC80 -32	EY51 -36	PCL88 -72	UCC85 -38
3V4 -37	30FL1 -63	EAF42 -50	EY86 -32	PCL800 -77	UCF80 -36
5V4G -37	30FL12 -72	EB91 -11	EZ40 -43	PXA4 -42	UCB42 -62
5Y3GT -30	30FL14 -72	EBC33 -40	EZ41 -43	PEN30C -76	UCH81 -22
5Z4G -37	30L1 -32	EBC41 -54	EZ80 -23	PFL200 -58	UCL82 -35
630L2 -58	30L13 -62	EBC90 -22	EZ81 -24	PL36 -48	UCL83 -55
6A15 -11	30L17 -73	EBF80 -33	GZ30 -37	PL81 -46	UF41 -62
6AM6 -13	30P4 -65	EBF89 -31	GZ32 -43	PL81A -51	UP89 -33
6AQ5 -26	30P12 -77	ECC81 -18	GZ34 -48	PL82 -33	UL41 -60
6AT6 -22	30P19 -65	ECC82 -23	KT41 -77	PL83 -35	UL44 £1-00
6AUG -22	30PLL -63	ECC83 -35	KT61 -48	PL84 -33	UL84 -35
6BA6 -22	30PLL3 -88	ECC85 -28	KT66 -83	PL500 -65	UM84 -22
6BB6 -23	30PLL4 -70	ECC804 -60	LN319 -63	PL504 -67	UV41 -41
6B6 -42	30PL15 -90	ECP80 -30	LN329 -72	PL508 £1-17	UY85 -28
6BW7 -60	35L6GT -43	ECP82 -30	LN339 -63	PM84 -37	VF4B -77
6C10G £1-10	35W4 -25	ECH35 -30	N78 -87	PX25 £1-17	Z77 -22
6F14 -45	35Z4GT -25	ECH42 -63	P61 -50	PY32 -55	Transistors
6P23 -71	807 -25	ECH81 -54	PA8C80 -55	PY33 -55	AC107 -17
6P25 -62	6063 -62	ECH83 -41	PC86 -51	PY81 -26	AC127 -18
6K7G -12	AC/VP2 -77	ECH84 -37	PC88 -51	PY82 -26	AD140 -37
6K9G -17	AZ91 -47	ECL80 -35	PC96 -42	PY83 -28	AP115 -20
6P28 -60	B349 -65	ECL82 -33	PC97 -40	PY88 -34	AP116 -20
68L7GT -67	B729 -82	ECL85 -40	PC900 -37	PY800 -37	AP117 -20
6V6G -18	CCH35 -67	EF39 -23	PC84 -32	PY801 -37	AP118 -48
6V6GT -32	CL33 -92	EF41 -29	PC95 -30	R19 -32	AP125 -17
6X4 -23	CY31 -33	EF80 -24	PC98 -45	R20 -65	AP127 -17
6X5GT -23	DAK32 -37	EF85 -31	PC99 -47	U25 -68	OC26 -25
10P13 -60	DAF91 -21	EF86 -31	PC189 -51	U26 -65	OC44 -15
12AH £2-25	DAF96 -36	EF89 -26	PCF805 -85	U47 -88	OC45 -12
12AT7 -18	DF33 -38	EF91 -13	PCF80 -50	U49 -65	OC71 -12
12AU6 -23	DF91 -16	EF183 -28	PCF82 -32	U78 -24	OC72 -12
12AU7 -23	DF96 -36	EF184 -32	PCF86 -47	U191 -62	OC73 -12
12AX7 -23	DH77 -22	EH90 -42	PCF800 -67	U193 -42	OC81 -12
19BG6G -23	DK32 -37	EL33 -43	PCF801 -39	U251 -78	OC81D -12
20F2 -67	DK91 -28	EL34 -47	PCF802 -45	U301 -62	OC82 -12
20P3 -85	DK92 -42	EL41 -55	PCF805 -67	U329 -72	OC82D -12
20P4 -92	DK96 -36	EL84 -24	PCF806 -60	U801 -98	OC170 -22

READERS RADIO

85 TORQUAY GARDENS, REDBRIDGE, ILFORD,
ESSEX. Tel. 01-550 7441

Postage on 1 valve 5p, on 2 or more valves 3p per valve extra.
Any Parcel Insured against Damage in Transit 3p extra.

T.V. TUBES **"VIDEOCHROME"** T.V. TUBES

FOR BRILLIANCE & DEFINITION

COMPARE
OUR
PRICES

17" £5-00
19" £5-50
21" £7-00
23" £7-50

Add 75p for RIMBAND Types
CASH OR CHEQUE WITH ORDER

TRADE SUPPLIED

ALL TUBES PRECISION REBUILT AT OUR OWN
FACTORY BY SKILLED CRAFTSMEN ● EACH TUBE
BENCH AND SET TESTED TO A VERY HIGH
STANDARD BEFORE DESPATCH

PRICES FOR TWIN PANEL TUBES
AVAILABLE ON REQUEST

2 YEARS GUARANTEE ● FREE
DELIVERY ANYWHERE IN THE U.K.

VIDEOCHROME TUBES LTD.

25 BELLEVUE AVENUE
RAMSGATE, KENT. Tel. THANET 52914

BENTLEY ACOUSTIC CORPORATION LTD.

38 CHALCOT ROAD, CHALK FARM, LONDON, N.W.1
THE VALVE SPECIALISTS Telephone 01-722 9900

0A2	0.30	6BH6	0.45	6SA7M	0.35	12BE6	0.30	6RA7GT0-35	0.30	DL92	0.20
0B2	0.30	6BQ6	0.43	6SC7GT		12BH7	0.40	30L17	0.78	DL94	0.32
0Z4	0.23	6BQ5	0.24		0.33	12E1	0.85	30P4MR		DL96	0.87
1A3	0.23	6BQ7A	0.38	6BG7GT		12J7GT0-33		AC044	1.18	DM70	0.30
1A5	0.25	6BR7	0.79		0.33	12K5	0.50	30P12	0.69	DM71	0.38
1A7GT	0.37	6BR8	0.63	6BH7	0.63	12K7GT		30P19/30P4		DW4/350	0.38
1D5	0.38	6BS7	1.25	6SK7T	0.35	12Q7GT	0.34	AC2/PEN/		DW4/500	0.38
1D8	0.48	6BW6	0.72	6SK7GT			0.28	30PL1	0.69	ECH21	0.63
1FD1	0.35	6BW7	0.65		0.23		0.28	30PL12	0.37	ECH42	0.64
1G6	0.30	6BZ6	0.33	6U4GT	0.60	12SA7GT		30PL13	0.78	ECH81	0.29
1H5GT	0.35	6C6	0.19	6U7G	0.53		0.40	30PL14	0.75	ECH83	0.40
1L4	0.13	6C9	0.73	6V6G	0.18	12SC7	0.35	30PL15	0.98	ECH84	0.38
1LD5	0.30	6CD6G	1.15	6V6GT	0.33	12SG7	0.28	35A3	0.50	EY86/7	0.33
1LN5	0.40	6CH6	0.38	6X4	0.22	12SH7	0.15	35A5	0.75	EY88	0.43
1NDGT	0.39	6CL6	0.48	6X5GT	0.25	12SJ7	0.23	35D5	0.70	EY91	0.63
1R5	0.28	6CW4	0.63	6Y6G	0.55	12SK7	0.24	35L6GT		EZ35	0.25
1R4	0.24	6D6	0.15	6Y7G	0.63	12SQ7GT		35W4	0.44	EZ40	0.40
1R5	0.22	6F1	0.63	7B6	0.58		0.50	ATP4	0.12	EZ41	0.43
1U4	0.29	6F6	0.63	7B7	0.58	14H7	0.48	AZ1	0.40	EZ80	0.23
1U5	0.48	6F6G	0.25	7C6	0.30	14H7	1.15	3Z3GT	0.50	EZ81	0.24
2D21	0.35	6F12	0.17	7F8	0.28	19A0Q5	0.24	AZ41	0.53	EZ90	0.22
3A4	0.20	6F13	0.33	7H7	0.28	19H1	2.00	B36	0.30	EF37A	0.35
3A5	1.00	6F15	0.65	7R7	0.65	20D1	0.65	B36	0.30	EF39	0.40
3B7	0.25	6F18	0.45	7V7	0.25	20D4	1.05	50B5	0.35	EF40	0.50
3D6	0.19	6F23	0.72	7Z4	0.70	20F2	0.70	50C3	0.32	EF41	0.50
3Q4	0.33	6F24	0.65	8B4G	0.40	20L1	0.95	50CDG	2.17	EF42	0.30
3Q5GT	0.35	6F25	0.65	9D7	0.78	20P1	0.85	D63	0.25	EF43	0.38
3S4	0.29	6F28	0.70	10C1	1.25	20P3	0.40	D77	0.12	EF80	0.23
3V4	0.32	6F32	0.15	10C2	0.50	20P4	0.93	DAC32	0.35	EF83	0.48
5R4GY	0.63	6H6GT	0.15	10D1	0.50	20P5	1.00	DAF91	0.22	EF85	0.29
5V4G	0.38	6J5G	0.19	10D2	0.75	25A6G	0.25	DAF96	0.35	EF86	0.32
5Y3GT	0.28	6J5GT	0.28	10F1	0.75	25L6G	0.28	DC90	1.90	EF87	0.32
5Z3	0.45	6L6	0.15	10F9	0.45	25Y5	0.38	DD4	0.53	EF92	0.13
6Z4G	0.35	6J7G	0.24	10F18	0.35	25Y6G	0.48	DF33	0.35	EF97	0.55
6J30L2	0.58	6J7GT	0.38	10LD11	0.63	25Z4G	0.30	DF91	0.14	EF98	0.65
6AG6	0.33	6K7G	0.10	10P13	0.65	26Z5	0.40	DF96	0.65	EF183	0.30
6AC7	0.15	6K7GT	0.23	10P13	1.10	25Z6G	0.45	DF97	0.63	EF184	0.30
6AG5	0.28	6K8G	0.30	10P18	0.33	30C1	0.30	DH63	0.30	EF190	0.50
6AK6	0.25	6L1	0.38	12A6	0.63	30C15	0.65	DH76	0.28	EF190	0.50
6AK6	0.30	6L6GT	0.39	12AC6	0.40	30C17	0.80	DH77	0.28	HVR2	0.53
6AM6	0.17	6L7GT	0.63	12AD6	0.40	30C18	0.64	DH81	0.58	HVR2A0-53	
6AQ5	0.28	6L18	0.45	12AE6	0.48	30F5	0.80	DH107	0.58		
6AR6	1.00	6L19	1.38	12AT6	0.23	30FL1	0.64	DK92	0.37		
6AT6	0.20	6L20	0.48	12AT7	0.19	30FL2	0.78	DK91	0.28		
6AV6	0.30	6P28	1.25	12AU6	0.24	30FL12		DK92	0.43		
6BB6	0.13	6Q7	0.43	12AV6	0.28	30FL14	0.73	DK96	0.37		
6BA6	0.23	6Q7G	0.30	12AX7	0.23	30L1	0.72	DK96	0.37		
6BE6	0.24	6R7	0.55	12AY7	0.68	6R7G	0.35	30L15	0.64		

REBUILT TELEVISION TUBES

STANDARD TYPES:

17"	£5.00	21"	£6.00
19"	£5.50	23"	£6.50

'PANORAMA' & 'RIMGUARD' TYPES:

19"	£7.00	23"	£9.00
-----	-------	-----	-------

TWIN PANEL or BONDED FACE TYPES:

19"	£7.50	23"	£9.50
-----	-------	-----	-------

- ★ Complete new gun fitted to every tube.
 - ★ Two years' guarantee.
 - ★ Free delivery by our own transport within 25 miles of London. Over this distance 75p extra for carriage and insurance (Passenger Train).
- We have been rebuilding tubes for the past 12 years and can supply any type including 11", 12", 13", 16", etc. and colour tubes. Trade enquiries invited.

N.G.T. ELECTRONICS LTD.,
22 Anerley Station Road,
London, S.E.20
Telephone: 01-778 9178

EX RENTAL TV's

19" — £29.95
23" — £39.95

All Channels 405/625
2 Years Guarantee.
Free List by return.

TEAK HI-FI STEREO CABINETS £14.95

Brand New 44" wide x 16" deep x 18" high with Legs. A superb piece of furniture. Carr. £1.00.

PRESS BUTTON SWITCHING UNITS. 4 Banks 17p. 6 Banks 27p P. & P. 5p.

TV TUBES REBUILT GUARANTEED 2 YEARS

TRANSISTORS Post Free

AC 126	AF 170	OC 81
AC 128	OC 44	OC 81D
AF 114	OC 45	
AF 117	OC 71	15p each

POTENTIOMETERS 23p each

Double & Switched	500 KΩ/500 KΩ	31" shaft
Double & Switched	500 KΩ/100 KΩ	2" shaft
Double & Switched	1 MEG/100 KΩ	11" shaft

Post. & Pack. 5p.—4 for 10p

KNOBS 100,000 to clear (Brand New)

100 assorted Radio & T.V. knobs 50p. Postage 10p. (If you require sets 2 to 5 just ask)

DUKE & CO. (LONDON) LTD.

621/3 Romford Road, Manor Park, E.12
Phone 01-478 6001-2-3 Stamp for Free List

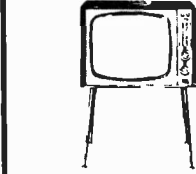

17" Slim line TV's £11.95, 19" Slim line TV's £15.95. Guaranteed 2 years. Send for List. Carr. & Ins. all sets £1.95. Daily demonstrations to personal shoppers.

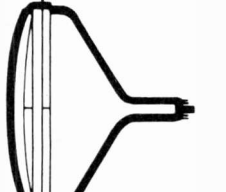

14"—£3.95, 17"—£5.95, 21" & 23"—£6.45. Exchanged Bowls. Carr. 53p.

19" TV's

Ex Rental Television sets as they come from customers, not cut or robbed. Fair sets at fair prices.

TRADE ONLY

Telephone or call

WILLOW VALE ELECTRONICS LTD
Wholesalers to the Service Engineer

**42 WEST END, STREET,
SOMERSET**

Tel: 045-84 2597



BUILD YOURSELF A CCTV CAMERA with the NEW BEUKIT

The kit includes all parts necessary to make a fully operational camera, complete with instruction manual.

Price £45.50 only
(excluding tube)

Optional extras: Vidicon from £5, RF kit £3.75, lenses, tripods, test, etc.

Send s.a.e. for further details:

Beulah Electronics (1970) Ltd.
P.O. Box 234, Shepperton, Middx.

UHF. COLOUR AND TELEVISION SPARES

COLOUR PLESSEY SCAN COILS £5-75 p.p. 35p, **CONVERGENCE COILS** £3-80 p.p. 25p, **BLUE LATERAL** £1-25 p.p. 9p, or Complete Set £10 p.p. 50p. Leading British Makers Surplus, **SCAN COILS** £3-50 p.p. 35p, **CONVERGENCE COILS** £2-75 p.p. 25p, **LUMINANCE/CHROMINANCE PANEL** £1 p.p. 25p, **INTEGRATED TRANSISTORISED DECODER UNIT** including Circuits £1-25 p.p. 10p, **LINE OUTPUT TRANSFORMER** including EHT and FOCUS ASSEMBLY £4-50 p.p. 35p. (Shop customers only, large assortment Colour Panels of various makes). **ALSO COLOUR TV CAMERA UNITS**

COLOUR TV MONITOR PANELS Designed to highest BBC standards. PAL filter & delay £8-00, Chrominance £6-00, Luminance £4-50, Encoded Video Input £2-50 pp 25p.

UHF 625 conversion kits and tuners available at reduced prices. Lists available.

UHF Integrated transistd. 6 position push button tuners, leading British makers surplus £4-50 p.p. 35p. Transistd. IF panels (salvaged) £2-50 p.p. 25p.

MURPHY 600/700 series UHF conversion kits in cabinet plinth assembly can be used as separate UHF receiver £7-50 p.p. 50p. 625 IF amplifier incl. 5 valves and circuit £3 p.p. 35p.

SOBELL/GEC Dual 405/625 IF amp and o/p chassis incl. circuit £1-65 p.p. 30p. **ULTRA 1980 C to 2384 625 IF amp & switch** incl. circuit £1-50 p.p. 30p. **PHILIPS 625 D/C IF panel** incl. circuit £1 p.p. 25p. **GEC 2015 Series D/C Dual 405/625 IF Panel** incl. circuit data £2-15 p.p. 30p.

UHF tuners transistd. incl. S/M drive or push button £5-25 p.p. 25p.

EKCO/FERRANTI UHF tuner kit, incl. valves, slow motion drive, knobs, leads, aerial panel £5-50 p.p. 30p.

TV SIGNAL BOOSTER UNITS Latest PYE/LABGEAR all station UHF/VHF transistd. "Set back" mains operated £7-90 UHF Masthead £5-25 p.p. 25p.

FIREBALL TUNERS Ferg., HMV, Marconi. New £1-90, others salvaged 90p p.p. 25p.

PULSE BUTTON Plessey, Ekco, Ferranti £1-50 pp 25p. **TURRET TUNERS** Pye 11u (export type) 75p, AB Dual Standard Suitable Ferguson, Baird, KB etc. 75p, Cydon C 75p, Ferguson MT7 £2-75, GEC 2018/9 £4-50 pp. 25p. Large selection channel coils.

LINE OUTPUT TRANSFORMERS. Popular types available, brand new replacements, fully guar. A selection which can be supplied p.p. 25p. C.O.D. 25p.

PHILIPS 17TG100 Range		LOPT Inserts p.p. 15p	
STELLA 1011/1029 ..	£3-50	Alba 655, 656 ..	£1-75
PHILIPS 19TG170, 210 series ..	£4-50	Cossor 933 to 950	£1-75
BUSH TV53 to 69 £2, 95 to 135	£4-50	Ekco TP308 ..	£1-75
EKCO 221 to 331 (U25 or U26 types)	£3-50	Emerson 700 range ..	£1-75
FERRANTI 1001/19 (U25 or U26)	£3-50	Ferranti 14T5 to 21K6 ..	£1-75
EKCO 342 to 394, FERRANTI 1021 to 1065 ..	£3-75	KB, NF70, OV30, PV40, PVP20, QV10, 20, 30 ..	£1-75
EKCO, FERRANTI 418, 1093 etc.	£3-50	KB/RGD Featherlight ..	£2-50
DECCA DM17, 3, 4 (70;) DR95, 101/606 ..	£3-95	KB/RGD VCI, 2, 3, 4 ..	£1-75
FERG 305 to 436, 505 to 727	£3-75	PETO SCOTT 733/738 ..	£1-75
FERG, HMV, MARCONI, ULTRA, PHILCO 3600, 2600, 4600, 6600, 1100, Jellypot ..	£3-75	Philco 1961, 1030 series ..	£1-75
KB QVP20, QV20/1 to S.V. 20 ..	£2-75	Phillips 17TG100 range ..	£1-75
KB PV P20, VC1 to VC11 ..	£4-00	Pye, VT4, VT7 ..	£2-15
MARCONI VT157 to 172 ..	£3-75	RGD D17, 590 to 619 ..	£1-75
GEC 302 to 346, £2-50, 448 to 452	£3-25	REG 10-4, 10-17 to 192 ..	£1-75
GEC 454/6, 2000 series ..	£4-50	Ultra 1770, 1780	£1-75
HMV 1865, 9, 1870/6, 1890 to 1924 ..	£3-75	PRACTICAL TV 625 RECEIVER	
PYE CTM/CW series (printed circuit) 17/21, 17/S, 110 to 510, 700, 830, 11U to 40F ..	£3-50	Integrated push button transistd tuner ..	£4-50 p.p. 25p
PAM, INVICTA equiv. LOPTS to above PYE ..	£3-50	Transistorised IF panel ..	£4-75 p.p. 25p
PETO SCOTT 1419 to 1725	£1-75, £2-50	850 line output transformer ..	£3-75 p.p. 25p
SOBELL/McMICHAEL TPS 173, 180, T23, 24, 178, 278, SC24, 270, MP17, 18, M72, M74 ..	£2-50	850 field output transformer ..	£1-62 p.p. 15p
TPS 781, 278, SC34, 370, MP27, M75, 76, 93 ..	£3-25	850 scan coils ..	£3-90 p.p. 25p
195, 282 to 288, 762, 763 ..	£3-25	(p.p. on complete set of 5 items 50p)	
SOBELL 196/7, 1000 series ..	£4-50	VALVE BASES B9D for PL500 series and colour 12ip p.p. 5p	
PHILCO 1010 to 1021 ..	£2-25	SPECIAL OFFER Leading British makers surplus 625 single standard 625 TV chassis, latest design, almost complete, includes transistd IF stages, frame and line time bases, transformers, etc., incl. circuit £3-65 p.p. 50p.	
ULTRA 1770 to 2834 ..	£3-75		

MANOR SUPPLIES

172 WEST END LANE, LONDON, N.W.6

(Near W. Hampstead tube stn: 28, 59, 155 Bus Routes) 01-794 8751

MAIL ORDER: 64 GOLDERS MANOR DRIVE, LONDON, N.W.11

In just 2 minutes, find out how you can qualify for promotion or a better job in Engineering...

That's how long it will take you to fill in the coupon below. Mail it to B.I.E.T. and we'll send you full details and a free book. B.I.E.T. has successfully trained *thousands* of men at home – equipped them for higher pay and better, more interesting jobs. We can do as much for YOU. A low-cost B.I.E.T. Home Study Course gets results fast – makes learning easier and something you look forward to. There are no books to buy and you can pay-as-you-learn on 'SATISFACTION – OR REFUND OF FEE' terms. If you'd like to know how just a few hours a week of your spare time, doing something constructive and enjoyable, could put you out in front, post the coupon today. No obligation.

WHICH SUBJECT WOULD INTEREST YOU?

Mechanical

A.M.S.E. (Mech.)
Inst. of Engineers
Mechanical Eng.
Maintenance Eng.
Welding
General Diesel Eng.
Sheet Metal Work
Eng. Inspection
Eng. Metallurgy
C. & G. Eng. Crafts
C. & G. Fabrication

Draughtsmanship

A.M.I.E.D.
Gen. Draughtsmanship
Die & Press Tools
Elec. Draughtsmanship
Jig & Tool Design
Design of Elec. Machines
Technical Drawing
Building

Electrical & Electronic

A.M.S.E. (Elec.)
C. & G. Elec. Eng.
General Elec. Eng.
Installations & Wiring
Electrical Maths.
Electrical Science
Computer Electronics
Electronic Eng.

Radio & Telecomms.

C. & G. Telecomms.
C. & G. Radio Servicing
Radio Amateurs' Exam.
Radio Operators' Cert.
Radio & TV Engineering
Radio Servicing
Practical Television
TV Servicing
Colour TV
Practical Radio & Electronics (with kit)

Auto & Aero

A.M.I.M.I.
MAA IMI Diploma
C. & G. Auto Eng.
General Auto Eng.
Motor Mechanics
A.R.B. Certs.
Gen. Aero Eng.

Management & Production

Computer Programming
Inst. of Marketing
A.C.W.A.
Works Management
Work Study
Production Eng.
Storekeeping
Estimating
Personnel Management
Quality Control
Electronic Data Processing
Numerical Control
Planning Engineering
Materials Handling
Operational Research
Metrication

Construction

A.M.S.E. (Civ.)
C. & G. Structural
Road Engineering
Civil Engineering
Building
Air Conditioning
Heating & Ventilating
Carpentry & Joinery
Clerk of Works
Building Drawing
Surveying
Painting and Decorating.
Architecture
Builders' Quantities

General

C.E.I.
Petroleum Tech.
Practical Maths.
Refrigerator Servicing.
Rubber Technology
Sales Engineer
Timber Trade
Farm Science
Agricultural Eng.
General Plastics

General Certificate of Education

Choose from 42 'O' and 'A' Level subjects including:
English
Chemistry
General Science
Geology
Physics
Mathematics
Technical Drawing
French
German
Russian
Spanish
Biology
B.I.E.T., and its associated schools have recorded well over 10,000 G.C.E. successes at 'O' and 'A' level.

WE COVER A WIDE RANGE OF TECHNICAL AND PROFESSIONAL EXAMINATIONS.

Over 3,000 of our Students have obtained City & Guilds Certificates. Thousands of other exam successes.

THEY DID IT—SO COULD YOU

"My income has almost trebled... my life is fuller and happier." – Case History G/321.

"In addition to having my salary doubled, my future is assured." – Case History H/493.

"A turning point in my career – you have almost doubled my standard of living." – Case History K/662.

"Completing your Course meant going from a job I detested to a job I love." – Case History B/461.

FIND OUT FOR YOURSELF

These letters – and there are many more on file at Aldermaston Court – speak of the rewards that come to the man who has given himself the specialised know-how employers seek. There's no surer way of getting ahead or of opening up new opportunities for yourself. It will cost you a stamp to find out how we can help you.

Free!

Why not do the thing that really interests you? Without losing a day's pay, you could quietly turn yourself into something of an expert. Complete the coupon (or write if you prefer not to cut the page). We'll send you full details and a FREE illustrated book. No obligation and nobody will call on you... but it could be the best thing you ever did.

BRITISH INSTITUTE OF ENGINEERING TECHNOLOGY

Dept D257 Aldermaston Court, Reading RG7 4PF.

(Write if you prefer not to cut this page)



BIET

POST THIS COUPON TODAY

To: B.I.E.T., Dept D257 Aldermaston Court, Reading RG7 4PF
Please send me book and details of your Courses in

Name..... Age.....

Address.....

Occupation.....