

ST. KESN

# Practical TELEVISION

MAY 1966

2/-

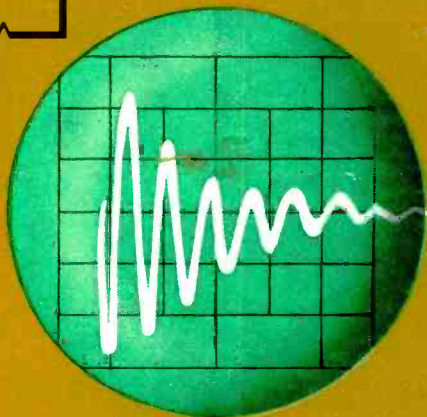
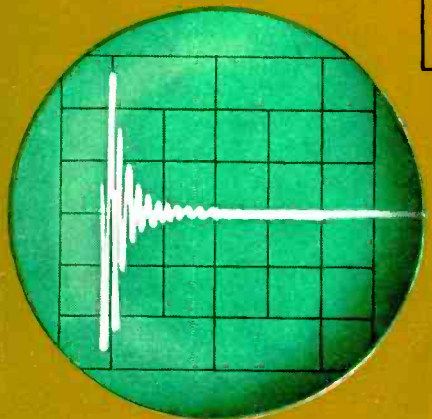
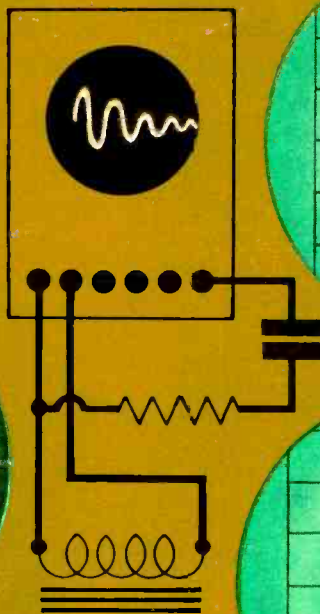
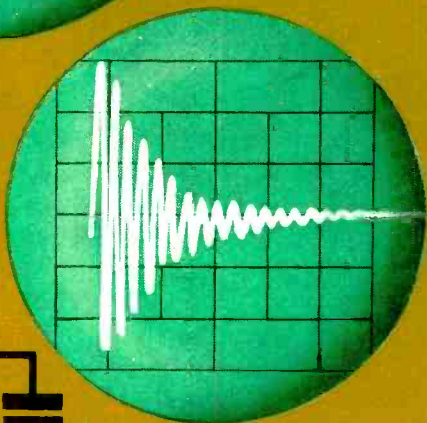
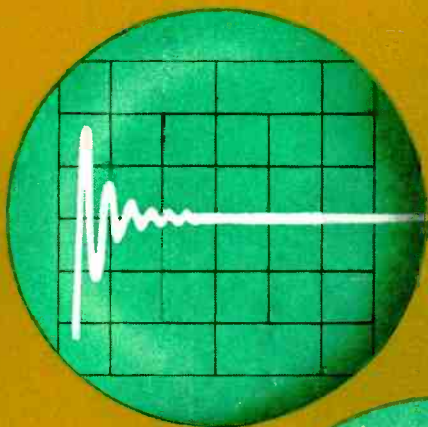
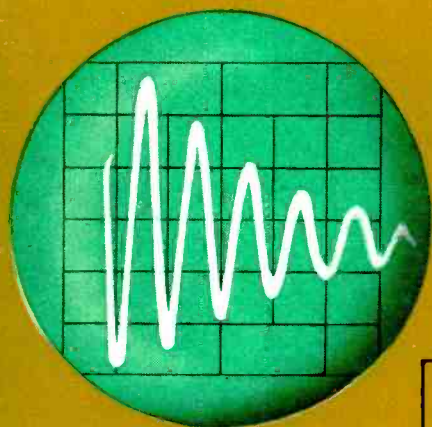

**TESTING TRANSFORMERS  
WITH AN  
OSCILLOSCOPE**

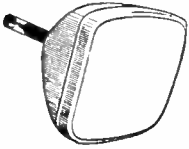

**"SABRINA"  
STILL WELL IN  
FRONT**

**COMPLETELY REBUILT C.R. TUBES  
ALL TYPES**

12" now ... ..	£5. 0.0	} For Single Tubes
14" to 17" now ... ..	£5.10.0	
19" now ... ..	£6.15.0	
21" now ... ..	£8. 0.0	

ALL C.W.O.—TRADE SUPPLIED

**Special Bonus Scheme for Service  
Engineers—Reducing to:**

12"—87/6; 14"/17"—97/6; 21"—147/6

FREE Pass. transit & Ins. anywhere in British  
Isles or N. Ireland (12 months' guarantee).

**ALSO FULL RANGE OF VALVES**  
(Guaranteed 12 months)

**SABRINA C.R. TUBE CO.**  
Electron Works, North Bar  
**BANBURY, OXON**  
Telephone 2390

**TWO-YEAR GUARANTEE**  
On all our Slimline TV's send for free list

---

**EX-RENTAL TELEVISION**

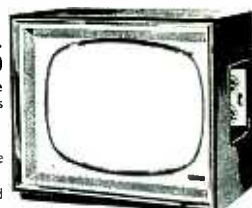
14 in. £7.10.0	17 in. £11.10.0	
12 months 3 star guarantee ★ Tube ★ Valves ★ Components <b>COLOURED FREE LIST</b> Channels for all areas Demonstrations daily from Large Selection		

Personal collection or insured  
Carr. 14in. 20/-; 17in. 30/-

---

**TWO-YEAR GUARANTEED TUBES**

14 in. 59/6		100% <b>REGUNNED</b> Add 10/- or old tube. 110/-—30/- on old tube. Carr. 10 S. 14in. Slim- line 17 and 19in. — overseas postage 30/-
17 in. 79/6		
21 in. and all Slimline Tubes 99/6		

---

**EX-MAINTENANCE TESTED TUBES**

17in.—35/- Most makes and types available. 14in.—15/-  
Guaranteed good picture. Carriage 5 - extra.

---

**VALVES** £1 per 100. Assorted TV and Radio  
Surplus ex-rental dismantled receivers. Post 4/6  
send for list.

**RADIOGRAM CABINETS.** from £8.0.0. Latest  
Design. Personal shoppers only.

**RESISTORS.** 5/- per 100. New Mostly High Stabs.  
Assorted. P. & P. 2/6. Overseas 3/6.

---

**DUKE & CO. (LONDON) LTD.**  
621 3 Romford Road, Manor Park, E.12  
Liverpool St.—Manor Pk.—10 mins.  
Phone: ILFord 600-1-2-3. Stamp for free list

**FREE TO AMBITIOUS ENGINEERS**  
— THE LATEST EDITION OF ENGINEERING OPPORTUNITIES

**Have you sent for your copy?**  
ENGINEERING OPPORTUNITIES is a highly informative 156-page guide to the best paid engineering posts. It tells you how you can quickly prepare at home for a recognised engineering qualification and outlines a wonderful range of modern Home Study Courses in all branches of Engineering. This unique book also gives full details of the Practical Radio & Electronic Courses, administered by our Specialist Electronics Training Division—the B.I.E.T. School of Electronics, explains the benefits of our Employment Dept. and shows you how to qualify for five years promotion in one year.

**SATISFACTION OR  
REFUND OF FEE.**

Whatever your age or experience, you cannot afford to miss reading this famous book. If you are earning less than £30 a week, send for your copy of "ENGINEERING OPPORTUNITIES" today FREE.

**WHICH IS YOUR  
PET SUBJECT?**

- Mechanical Eng.
- Electrical Eng.
- Civil Engineering
- Radio Engineering
- Automobile Eng.
- Aeronautical Eng.
- Production Eng.
- Building, Plastics
- Draughtsmanship
- Television, etc.

**GET SOME  
LETTERS AFTER  
YOUR NAME!**

- A.M.I.Mech.E
- A.M.I.C.E.
- A.M.I.Prod.E.
- A.M.I.M.I.
- A.I.O.B.
- B.Sc.
- A.M.I.E.R.E.
- City & Guilds
- Gen. Cert. of Education
- Etc., etc.

**PRACTICAL  
EQUIPMENT**

Basic Practical and Theoretical Courses for beginners in Radio, T.V., Electronics Etc. A.M.I.E.R.E., City & Guilds  
Radio Amateur's Exam R.T.E.B. Certificate P.M.G. Certificate Practical Radio  
Radio & Television Servicing Practical Electronics Electronics Engineering Automation

**INCLUDING  
TOOLS!**

The specialist Electronics Division of B.I.E.T. NOW offers you a real laboratory training at home with practical equipment. Ask for details

**B.I.E.T.  
SCHOOL OF  
ELECTRONICS**



**POST COUPON NOW!**

Please send me your FREE 156-page "ENGINEERING OPPORTUNITIES" (Write if you prefer not to cut page)

NAME .....

ADDRESS .....

.....

.....

SUBJECT OR EXAM THAT INTERESTS ME ..... 301B

**BRITISH INSTITUTE OF ENGINEERING  
TECHNOLOGY**  
(Dept. 301B), 29 Wright's Lane, London, W.8

**THE B.I.E.T. IS THE LEADING INSTITUTE OF ITS KIND IN THE WORLD**

# D. & B. TELEVISION (WIMBLEDON) LTD.

131 KINGSTON ROAD . SOUTH WIMBLEDON · London SW19

Telephone: CHerrywood 3955 and 3513

## LINE OUTPUT TRANSFORMERS

**ALBA**—655, 721, 766, 806, all at 62/- each.  
**BEEHOVEN**—B106, B109, B208, Inserts only at 30/- each.  
**BUSH**—TV33, TV36, TV57, TV68, M59, TV659, TV62, TV63, TV96, TV97, TV669, M59, Inserts only 30/- each.  
**ALL BUSH TRANSFORMERS OBTAINABLE. PRICES ON REQUEST.**  
**COSSOR**—R17A, 930, 931, 933, 934, 935, 937, 938, 939A, 939FA, all at 65/- each. 940, 942, 942A, 943, 944, 946, 949, 945B, 945, all at 56/- each. 94X, 950, all at 80/- each.  
**DECCA**—DM1, DM2A, DM3/DM4, DM4C, DM5, DM14, 444, 553, all at 68/- each. DM35, DM43, DM55, DM56, all at 53/- each. DM21C, DMG21, at 70/- each. DM22C, SRG-TV666, SRG-TV777, at 79/- each. DR19, DR19C, DR29C, DR39C, DR49C, all at 79/- each. DR31, DR32, DR34, DR41, all at 92/- each. DR61, DR71, at 72/- each. DR83, DR100, DR101, DR202, DR303, DR404, DR705, DR606, all at 92/- each.  
**DYNATRON**—TV30, TV35, at 50/- each.  
**ALL MODELS AVAILABLE. PRICES ON REQUEST.**  
**EKCO**—TC208, TC209, TC209A, T221, T231, T231E, T249, TC267, TC267A, TC268, TC269, T283, T284, T293, T311, T310, TGC316, T326, T327, T330, T330E, T341, all at 50/- each. T342, T344, T344E, T448, T448E, T356, TC312, T313, T413E, T355, all at 65/- each.

**FROM THIS MODEL ONWARDS TOO NUMEROUS TO LIST. ALL TYPES 72/- each.**

**EMERSON**—E709, E701, E704, E707, E708, E709, E710, E711, Portorama. These are supplied as an insert all at 30/- each.

**FERGUSON**—43T, 43AT, at 65/- each. 103T, 105T, 113T, 135T, 142T, 143T, 145T, all at 27/- each.  
 990T, 991T, 992T, 993T, 994T, 995T, 996T, 997T, 998T, all at 27/- each. 998T, 999T, at 27/- each. 305T, 307T, 312T, all at 65/- each. 306T, 308T, at 52/- each. 406T, 407T, 410T, 430T, 438T, all at 50/- each. 405T, 407T, at 65/- each. 506T, 508T, 516T, 518T, 538T, 538T, 540T, at 65/- each. 503T, 507T, at 65/- each.  
 604T, 606T, 608T, 616T, 619T, 636T, 640T, all at 65/- each. 648T, 725T, at 69/- each. 726T, 727T, at 72/- each.  
 3600, 3601, at 69/- each. 3602, 3604, 3611, 3612, 3614, at 66/- each. 3617, 3618, 3619, 3620, 3621, 3622, Thorn 900 Series, all at 72/- each. 3623, 3624, 3625, 3626, 3627, 3629, Thorn 900 Series, all at 82/- each.  
**FERRANTI**—14T2, 14T3, 14T3P, 14T4, 14T5, 17K3, 17K3P, 17T3, 17T3P, 17K4, 17K5, 17R4E, 17K6, 17R5K, 17R6K, 17T4, 17T4E, 17T5, 17T6, 17K4F, 17R4F. These are supplied as inserts all at 30/- each.  
 T1001, T1002, T1002P, T1004, T1005, T1021, T1011, all at 50/- each. T1012, T1023, T1034, T1027, all at 65/- each.

**G.E.C.**—BT302, BT303, BT304, BT306, all at 72/- each. BT312, BT314, BT315, BT318, BT319, all at 72/- each. BT320, BT321, BT322, BT324, BT326, BT328, BT329, all at 72/- each. BT448, BT449, BT450, BT451, BT452, all at 82/- each.

**ALL DUAL STANDARD MODELS CAN BE OBTAINED TO ORDER.**

**H.M.V.**—1865, 1869, at 50/- each.  
 1870, 1871, 1872, 1873, 1874, 1875, 1876, all at 52/- each.  
 1890, 1892, 1894, 1896, all at 65/- each.

**INVICTA. ALL MODELS AVAILABLE. PRICES ON REQUEST.**  
**KOLSTER-BRANDS**—NV70, OV30, OV30FM, OF100, PV70, PV70FM, PV100, all at 95/- each.  
 CV30 I, PV40, PV100 I, PVP20, PVP20 I, QV20, QV30, all at 115/- each. QV70, QV70FM, QV100, QVP20, RV10, RV20, RV50, all at 105/- each. RV20FM, RV30, RV30FM, RV70, RV80, SV20, TV15, TV20, TV30, all at 95/- each.

**MARCONI**—VT156, VT157, at 52/- each.

**MASTERRADIO**—All models available Rewind, at £3.10.0.

**MURPHY**—A 270, V290, V290A, V300, at 90/- each. V310, V310A, V320, V330, V350, at 72/- each. V410, V420, V430, V470, V480, V490, V500, V510, V519, V520, V530, V530P, V530D, V540, V540D, all at 90/- each. V649D, V658, V659A, at 72/- each.

**McMICHAEL**—M22T, M28NFC, M71T, M72T, M72NFC, MP14, MP14DL, MP17, at 72/- each. M74HFC, M74T, M24NFC, MP18, MP19, at 74/- ea. M75T, M76NFC, M76NFC, M723, M701T, M730, M740, M725, MP28, at 78/- ea. M77NFC, M74NFC, M1907G, M794, M7762, M7763, at 76/- ea. M7762DS, M7763DS, M7765DS, M7765DS-T, M7765, M7765DS, M7765DS-T, at 82/- each.

**PAM**—All models available. Prices on request.

**PETO SCOTT**—148A, TR16, 178A, TV1416, T1419, TV1716, TV1719, TV1720, TV1722, TV1725, TV1724, TV1418, TV1726, Inserts at 30/- each. TV1730, TV1731, at 72/- each.

**PYE**—V4, V7, V7A, V7T, at 72/-, V14, V14C, at 58/- each.

VT17, VT21, at 62/- each. PV110, V110, at 69/- each. V200, V400, at 82/- each. V230, V210, V220, at 68/- each.

V300, V310, V410 S, V310P, at 52/- each. V410, V500, at 68/- each. V510, V500A, at 72/- each. V700, V800A, at 72/- each.

CTM4, CTM1E, CTM1E5, CTM1T, and 310, Models at 72/- each. CS17, CW17, LB17BE, 17C11, at 62/- each. CTL388, CTL585, 17H8, 17Z18, at 56/- each. PTL17, RTL38P, at 58/- each. SP17, SP17E, 58/- each.

**ALL DUAL STANDARD MODELS PRICES ON REQUEST.**

**PILOT**—All models Rewind at £3.10.0 each.

**PORADYNE**—All models Rewind at £3.10.0 each.

**PHILCO**—1000, 1010, 1020, at 72/- each. 1019, 1021, 1023, at 75/- each. 1030, 1033, 1040, 1069, 1050, 1055, 1059, at 78/- each. 1109, 1105, 1110, at 72/- each.

**REGENTONE**—T14, 104, 104, 1047, 1021, Inserts only at 30/- each. T14, 104, 104, 1047, 1021, Inserts only at 30/- each.

**ROBELL**—T22, T23, T172, T178, T18447, T18147D, T18147, at 72/- ea. SC24, SC270, T24, T179, T278, T274, T1810, T18157, at 74/- ea. SC34, SC370, T25, T192, T193, T230, T293, T292, T18710, T18781, at 76/- each.

**ULTRA**—1453, VP1453, V1560, V1752, V1753, V1760, VR1762, at 42/- ea. WR1762, V1763, V1764, V2150, V2152, 2160, at 42/- each.

V1770, V1771, V1772, V1773, V1774, V1775, V2170, V2171, at 52/- each. V2172, V2173, V2174, V2175, V2176, V2177, at 52/- each.

V1780, V1781, V1782, V1783, at 75/- each. V1980, V1984, V1985, V1986, at 75/- each. V2380, V2384, at 75/- each.

## ALL BRAND NEW VALVES GUARANTEED 3 MONTHS

POSTAGE & PACKING ON VALVES 6d. EACH

AZ31	10/6	ECOS4	7/8	EM*5	10/-	PF*F806	10/-	UC*084	8/10	U193	7/-	10P14	11/-
DAF81	7/10	ECOS5	7/4	EY51	7/-	PC*LS2	8/4	UC*085	7/4	U251	11/8	20P2	11/-
DAF96	6/10	EC0F6	9/6	EY56	7/-	PC*LA3	9/8	UC*080	9/4	U281	13/8	20L1	12/6
DF91	7/10	EH45	13/-	EZ40	5/8	PC*LS4	8/8	UC*042	9/6	U282	13/9	20P1	15/-
DF92	6/10	EH42	8/6	EZ41	5/8	PC*LS5	8/8	UC*082	7/3	U301	13/9	20P3	12/-
DF96	7/10	EH81	7/-	EZ80	5/6	PC*LS6	8/8	UC*082	8/8	U301	13/9	20P4	12/-
DK91	7/10	ECL80	7/4	EZ81	5/6	PC*LS6	10/-	UC*LS3	10/8	U301	13/9	20P3	13/-
DK92	7/10	ECL82	8/6	EZ90	5/-	PL*1	8/4	UC*E1	7/6	U19	8/6	20P5	13/-
DK95	7/10	ECL83	10/6	EZ92	11/-	PL*2	8/4	UC*E2	9/-	U61	9/6	30L13	9/6
DL92	6/8	ECL86	8/8	EZ94	11/-	PL*3	8/4	UC*E3	7/6	U61	9/6	30L17	11/8
DL94	6/8	EF50	7/-	HB*90	6/4	PL*4	7/-	UC*E5	7/6	U614	15/-	30L18	10/-
DL96	6/8	EF55	7/-	PAB*CS1	7/6	PL*500	14/-	UC*E9	7/-	U615	12/6	20P5	10/-
DY86	7/-	EF56	9/4	PC*80	8/10	PL*33	9/6	UC*E1	7/6	U623	10/6	30FL1	19/3
DY87	7/-	EF59	7/-	PC*88	8/10	PL*80	6/-	UC*E6	10/6	U624	10/6	30FL4	19/8
EAB*CS0	7/8	EF42	9/4	PC*97	7/6	PL*83	7/-	UC*E8	8/8	U625	10/-	30FL12	19/8
EAF42	8/8	EF92	9/-	PC*84	7/4	PL*82	5/8	UC*E11	5/6	U625	10/-	30FL18	19/8
EB91	4/8	EF133	9/4	PC*CS5	7/4	PL*83	9/6	UC*E5	5/6	U628	9/8	30FL15	19/8
EB*CS3	11/2	EL13	10/6	PC*CS8	12/6	PL*88	7/-	UC*E11	15/8	U611	15/8	30L13	13/8
EB*41	7/8	EL34	9/9	PC*CS8	10/8	PL*80	7/-	UC*E4	12/6	U618	12/6	30L15	11/8
EB*41	6/8	EL36	9/9	PC*CS9	10/8	PL*81	7/-	UC*E5	12/6	U612	9/8	30P12	9/8
EBF50	7/8	EL41	8/-	PC*CS9	9/4	PL*82	5/8	UC*E11	15/8	U613	12/6	30P12	9/8
EBF59	7/8	EL44	6/4	PC*CS2	9/4	PL*84	7/-	UC*E3	7/6	U612	12/-	30P4	12/-
EC*81	7/4	EM80	7/8	PC*CS6	10/6	PL*81	7/-	UC*E11	10/3	U619	8/-	30P19	12/-
EC*82	7/4	EM81	7/8	PC*F801	10/-	PL*80	7/-	UC*E6	10/6	U618	8/-	30P13	12/8
EC*83	7/-	EM84	8, 8	PC*F802	10/-	PL*89	7/-	UC*E1	9/8	U613	12/6	30P14	11/8

We are open 9 a.m. to 6 p.m. Monday, Tuesday, Thursday and Saturday—9 a.m. to 7 p.m. Friday. Closed all day Wednesday.

SERVICE SHEETS. TELEVISION !! ALL MAKES AND MODELS 4/-, P. & P. 4d.

# CRT's Rebuilt

- RESCREENED
- RE-ALUMINISED

Regular buyers of Suffolk and Midland Tubes have learnt to rely on their outstanding quality. Every Tube fully guaranteed with proved performance reliability.

PRICES FROM £4.00 EACH  
The largest independent rebuilders in the U.K.

**SUFFOLK TUBES LTD**  
1/3 UPPER RICHMOND ROAD  
PUTNEY LONDON S.W.15  
Tel: Vandayke 4304/5267

**MIDLAND TUBES LTD**  
477/483 OLDHAM ROAD  
MANCHESTER 10  
Tel: Collyhurst 4412

## BENTLEY ACOUSTIC CORPORATION LTD.

THE NEW VALVE SPECIALISTS

38 CHALCOT RD, LONDON, N.W.1

MULLARD BY100 MIDGET SILICON RECTIFIERS

SPECIAL OFFER

E.M.I. Elliptical Speakers, 8 x 13 1/2in. Ceramic magnet, 8 or 15 ohms. 39/6 each. Packing 3/6 Brand new.

Nearest tube  
Chalk Farm

All goods  
advertised are  
in stock

Primrose  
9090

Output 250v. at 1 amp.  
No larger than a shirt button  
6/6 each

0A2	5/9	6CW4	24/-	10P14	11/6	35C5	8/3	DY86	6/6	ECH84	9/6	EM90	6/3	MHLD612/6	PL83	6/6	U26	7/6	UF89	5/6	OA81	3/6	
0B2	6/-	6D3	9/6	12A06	8/6	35L8GT	6/-	DY87	7/6	ECL80	5/9	EM81	7/-	MU12/14/4/6	PL84	6/3	U31	6/6	UL41	7/6	OA2210	7/6	
0Z44T	4/3	6P1	9/6	12AD6	9/6	35W4	4/6	EM82	24/-	ECL82	6/6	EM84	6/-	N87	10/6	PL500	14/-	U33	6/6	UL84	5/6	OC19	25/-
1D6	9/6	6P13	3/9	12A16	8/-	35Z	10/-	EM87	24/-	ECL83	10/-	EM85	8/9	N78	26/-	PM4	9/3	U35	10/6	UM4	17/6	OC22	23/-
1R5	4/-	6P23	9/3	12A16	4/6	35Z4GT	4/6	EM88C	13/6	ECL86	8/-	EM87	7/6	N108	26/8	PX4	9/-	U37	34/1	UM34	17/6	OC25	12/-
1R5	3/3	6P24	10/6	12A16	5/9	35Z5GT	5/9	E180F	19/6	EF22	6/6	EN81	10/-	PABCO8	6/3	PY31	6/9	U45	15/6	UM80	8/3	OC26	8/-
1T4	2/3	6J7G	4/6	12A16	5/9	50B5	6/6	EA50	1/6	EF36	3/6	EY81	5/6	P41	2/6	PY32	8/9	U76	4/6	U16	13/-	OC28	23/-
2D21	5/6	6K73	1/3	12BA6	5/3	50C5	6/6	EABCS0	5/9	EF37A	7/-	EY81	7/3	PC86	9/3	PY33	8/9	U91	9/6	U18	13/-	OC29	16/6
2X2	3/-	6K86	3/3	12BE6	4/9	50L8GT	6/-	EAF42	7/6	EF39	5/-	EY83	8/3	PC88	9/-	PY30	4/9	U251	9/-	UY1N	10/3	OC35	9/6
3A5	6/9	6K8GT	3/6	12BH7	6/-	72	6/6	EB34	1/-	EF40	4/9	EY84	9/6	PC95	9/6	PY81	5/-	U282	12/3	UY21	9/-	OC36	21/6
3Q9GT	6/9	6K26	24/-	12J7GT	7/3	85A2	6/6	EB41	4/9	EF41	6/6	EY86	5/6	PC97	9/6	PY82	4/9	U301	11/-	UY41	5/-	OC41	8/-
384	4/9	6L6GT	7/3	12K5	10/-	90A4G	8/76	EB91	2/3	EF42	3/9	EY87	6/-	PUB90	9/6	PY83	5/6	U304	6/-	UY85	4/9	OC44	4/9
3V4	5/-	6L78TM	5/6	19AQ5	7/3	90A4V	6/76	EB93	8/-	EF50	2/6	EY88	8/9	PC84	5/6	PY88	7/3	U301	15/-	NP4	14/6	OC45	3/6
5R4GY	8/6	6L18	10/-	20D1	10/-	90C1	15/-	EB41	6/6	EF50	4/3	EY91	3/-	PC85	6/9	PY80	5/9	U302	6/6	VP4B	12/-	OC46	22/6
5T4C	4/9	6L20	6/6	20P2	11/6	90C4G	42/-	EB81	6/3	EF83	9/9	EZ40	5/6	PC88	10/6	PY601	7/6	UABCO8	5/6	VR105	5/6	OC46	25/-
5V4	8/-	6P28	11/6	20L1	14/-	90C4V	42/-	EF90	5/9	EF85	4/6	EZ41	6/3	PC89	11/6	PZ30	9/6	UAF42	7/-	VR150	4/9	OC70	6/6
5Y3GT	4/9	6Q7G	5/6	20P1	12/6	150B2	16/6	EF83	7/3	EF86	6/6	EZ80	3/9	PC189	8/9	QV03/10	1/6	UB41	10/6	W107	10/6	OC71	3/6
5Z3	6/6	6H7G	5/3	20P3	12/-	807	11/9	EF89	5/9	EF89	4/3	EZ81	4/3	PC80	6/6	35/-	UB41	6/3	W729	17/6	OC72	8/-	
5Z4G	7/6	6H7GT	4/6	20P4	13/-	5763	7/6	EB121	10/3	EF91	3/-	EZ83	14/6	PC86	6/6	QV04/7	7/-	UB81	6/6	X41	10/-	OC73	16/6
6A5	5/9	6K5GT	5/3	20P5	11/6	7475	2/9	EB33	12/6	EF82	2/6	EZ84	10/-	PC84	5/6	R10	15/-	UBF80	5/6	X66	7/3	OC74	8/-
6A7	3/-	6SNTGT	4/6	25L6	4/6	ACSPEN	4/9	EB70	4/9	EF85	4/9	EZ87	14/6	PC86	8/3	R17	17/6	UBF89	6/3	X78	26/2	OC75	8/-
6A7G	5/9	6L44T	8/6	25Z40	6/6	AZ31	9/6	EB92	6/6	EF87	10/-	HA180	9/3	PC801	9/9	R18	9/6	UB121	10/9	X79	27/-	OC76	8/6
6A95	5/9	6V6G	3/6	25Z61T	8/-	AZ41	6/6	EB31	7/3	EF88	9/9	HA11D1	1/6	PC862	10/-	R19	6/9	UB92	6/3	X63	5/-	OC77	13/6
6A96	3/6	6X4	3/9	30C15	10/-	B36	4/9	EB36	4/6	EF88	7/3	18/6	PC865	8/4	R30	22/6	UB84	8/-	Transistors	0478	OC78	8/-	
6A97	5/9	6V6GT	5/3	30C17	11/9	CHL1	12/-	EB39	10/-	EF84	6/6	HL42D1	PC866	12/6	SP41	2/-	UC85	6/6	Good diodes	0881	OC79	4/-	
6A98	5/9	6030L2	9/9	30C18	8/-	CL33	11/6	EB81	3/6	HL90	9/6	19/6	PC182	8/6	SP61	2/-	UC86	8/3	AF102	27/6	OC81D	4/-	
6B46	4/9	7196	12/6	30P5	7/3	CV31	5/9	EB82	4/6	FK22	5/9	HN309	28/-	PC183	9/6	R125	27/2	UC82	8/-	AF114	11/-	OC82	10/-
6B46	4/3	7177	9/6	30P13	11/3	DA96	6/6	EB83	4/6	FL22	3/6	IVR12	8/9	PC184	7/6	T41	9/-	UC84	8/-	AF115	10/6	OC83	6/6
6B46	5/3	705	6/9	30P14	9/3	DD44	10/6	EB84	5/6	FL23	6/6	HA124	8/9	PC185	6/6	TI1233	6/9	UC81	6/6	AF116	10/-	OC84	8/-
6B46	5/6	7147	5/9	30L15	10/3	DM6	15/-	EB85	5/9	KL4	9/9	KTC3	8/-	PC186	8/9	TY66	11/6	UC82	7/6	AF117	5/6	OC150	8/6
6B47A	7/6	7147	12/6	30L17	11/6	DF96	6/6	EB88	8/9	EL26	8/9	KTC6	29/1	PC185	7/-	UD1	9/-	UC83	9/-	AF127	9/6	OC171	9/6
6B47B	8/3	7Y4	5/-	30P4	12/-	DF97	10/-	EB91	3/-	EL11	7/-	KT41	9/6	PC150D	1/2	UD11	7/6	UD41	6/9	AF186	27/6	OC171	27/6
6B48	8/-	9BW6	9/6	30P12	7/6	DK92	8/6	EB918	11/6	EL12	7/9	KT41	5/-	1.3	UD1	15/6	UD42	4/9	AF212	26/6	MAT100	7/9	
6B48	7/6	10C1	9/9	30P19	12/-	DK96	6/6	EB90	7/3	EL21	8/3	KT61	8/9	PC184	6/3	UD20	9/6	UD80	6/3	DA70	3/-	MAT101	8/6
6B48	5/-	10C2	12/-	30P11	9/6	DL72	15/-	EB92	6/3	EL23	6/9	KT63	3/9	PC183	10/3	UD2	5/9	UD83	6/9	DA73	3/-	MAT102	7/9
6C9	10/9	10P1	10/-	30P13	10/3	DL96	8/6	EB96	10/-	EL24	4/6	KT66	12/3	PC120	11/6	UD5	3/6	UD86	7/-	OA79	3/-	MAT123	8/6
6C16G	15/-	10L11	9/6	30P14	11/3	DM70	7/6	EB121	10/-	EL25	7/6	KT8	28/-	PL23	9/-								
6C16	6/6	10P13	12/-	30P15	9/6	DM71	9/9	EB135	8/-	EL26	7/3	KT61	4/9	PL26	9/-								
								EB142	8/-	EL30	2/6	KT62	5/6	PL28	13/-								
								EB181	5/9	EL35	5/-	KT63	5/6	PL81	9/9								
								EB183	6/6	EM71	15/6	MH14	7/6	PL82	4/3								

Terms of business:—Cash with order only—No C.O.D. Postage/Packing 6d. per item. Orders over £5 post free? Any parcel insured against damage in transit for only 6d. extra. All orders despatched on day of receipt. Orders welcome.  
Mon.—Fri. 9 a.m.—5 p.m. Sat. 9 a.m.—1 p.m.

We require for prompt cash settlement all types of valves, loose or boxed, but MUST be new. Offers made by return.

All goods are new first quality brands only and subject to makers' full guarantee. We do not handle manufacturers' seconds or rejects which are often described as 'new and tested' but which have a limited and unreliable life. Complete catalogue of over 1000 valves actually in stock with resistors, condensers, transformers, microphones, speakers, metal rectifiers with terms of business, etc., post free.

# Practical Television

## PROFESSIONAL STATUS

THE "servicing fraternity" has for many years been synonymous with a hotch-potch of qualified technicians, semi-skilled trouble-shooters, apprentices bright and dim, semi-professional part-timers, amateurs, bunglers, manglers—the lot!

The demarcation line between amateur and professional itself is blurred, for within the extremes there are efficient amateurs who would be a credit to any service department and, conversely, professionals who would do better as demolition workers. The scene is also confused in that some "amateurs" are employed by day in laboratories and other technical departments in industry and are often more knowledgeable than some full time technicians.

We are, therefore, not necessarily convinced that a professional is a good serviceman or that an amateur is a bad one. What *does* impress us is whether or not the technician holds an RTEB Certificate.

The Radio Trades Examination Board began work some two decades ago and provided the first real chance for technicians to prove their merit in both theoretical and practical spheres. The RTEB Servicing Certificate is *the* qualification for servicing work, distinguishing the skilled from the unskilled, eliminating the "Gentleman and Players" distinctions existing between amateur and professional repair men.

The RTEB is no mere formality. In the radio and TV sections, some 30% of candidates fail in both the Intermediate and Final Examinations. The standards are high, but realistic. Thus, a holder of the RTEB Final Certificate has evidence that he is one in whom the public can place trust and confidence in handling their radio and TV equipment.

We would like to see a much greater insistence, not only by the public but by the retail trade, in acknowledging the status implied by these RTEB Certificates. Industry is much more forward-thinking in this direction, where the qualification is a decided asset, and where the soldering iron and wet finger merchant is not suffered so lightly as he is—quite wrongly—by some retail departments and by a public all too quick to get something done "on the cheap".

Now following the RTEB comes the formation of the Society of Electronic and Radio Technicians, a logical step which gives the qualified service technician the opportunity of the true professional status he deserves. A specially commissioned article appears on page 363 of this issue.

MAY 1966  
VOL. 16 No. 188

## THIS MONTH

Teletopics	340
Testing Transformers with an Oscilloscope	342
by K. Royal	
Olympic II Transistor TV A New Line Scan Stage	346
by D. R. Bowman, B.Sc.	
Servicing TV Receivers—Defiant 9A30 and Associated Pageant Models— <i>continued</i>	350
by L. Lawry-Johns	
DX-TV	354
by Charles Rafarel	
LC Picometer Part 2	356
by M. L. Michaelis, M.A.	
Solid State Television	360
by K. T. Wilson	
TV Servicing—An Honourable Profession	363
by E. A. W. Spreadbury, M.I.E.R.E.	
TV Terms and Definitions Part 2	364
by Gordon J. King	
Trimming by Test Card	367
by G. R. Wilding	
The Service Engineer in the Home	369
by J. D. Benson	
Letters to the Editor	371
Meet the Setmakers Part 4	372
by P. Westland	
Trade News	377
Your Problems Solved	379
Test Case—42	381

OUR NEXT ISSUE DATED JUNE  
WILL BE PUBLISHED ON MAY 19th



# TELETOPICS

## THORN BRING IN AERIAL UNITS

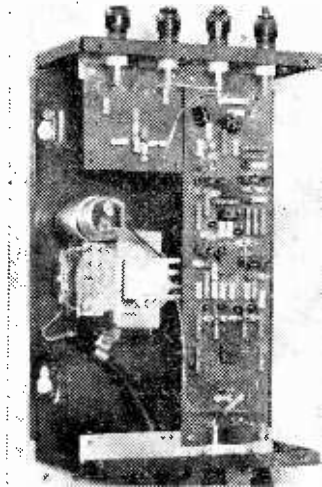

THORN Electronics, already well established in the field of television relay equipment, now introduce the first range of broad-band transistorised communal aerial equipment available in this country.

The "Triple T Minor" equipment, from this range, is shown above without its outer casing.

In this and the Triple T Major TV distribution equipments, provision is made for the injection of converted u.h.f. channels.

## RTRA replies to PMG

### President deplores licence suggestion

THE Radio and Television Retailers' Association reacted sharply to suggestions that retailers should be compelled to surrender names of customers to the GPO for the purpose of tracing television and radio licence evaders.

In a statement defining the RTRA's position, its President, Mr. Harry Horner, deplored any moves by the Postmaster General to introduce such legislation.

His statement follows one by the PMG which gave a figure of 1.8 million "evasions" and a possible £8 million loss of revenue to the BBC by the licence dodgers.

The Association's main objection to the proposal, is the administrative costs their members would incur in supplying the names of their customers. These costs would multiply considerably when changes of address occurred during terms of contract.

Mr. Horner's statement goes on to deprecate the whole present system of licensing and suggests as an alternative, that the BBC be financed from public funds. This, it says, would end a nonsensical position where the Government, having failed to get a large section of the public to pay the licence fee, would have the retailer "snoop" on his customers.

In a final suggestion the Association claims to up the penalty evasion from £2 to £25, would have an immediate effect on unlicensed viewers.

## EMI EUROPEAN EXPORTS TOP £100,000

EUROPEAN exports totalling £137,000 will result from contracts recently won by EMI Electronics in three countries.

The biggest order comes from Spain where EMI will supply and install control and switching equipment for the Spanish television network. Plug-in semiconductor modular equipment will be used for programme switching while other equipment will co-ordinate the outputs of nine studios, video tape recordings, telecine and remote signals.

Under a contract from Belgium, EMI will install a television and sound distribution system in Brussels' new studio centre.

The system will receive and distribute five off-air television channels — two Belgian, two French and one Dutch—and 17 locally originated channels. The system, which will handle NTSC, PAL or SECAM colour signals, will also distribute Band II f.m. broadcasts.

The third contract comes from the Swiss Television Service and is for cameras, control units and ancillary equipment.

## 'Minibook' No. 2

LAST month Teletopics contained details of the first of a new series of booklets produced by the Mullard Educational Service. The second of these "minibooks" as Mullard call them, is just released with the title "Principles of X-rays".

Like the first minibook "Principles of Electrostatics", this latest publication is based on filmstrips and slides under the same title which the Educational Service has already produced.

The seven sections of "Principles of X-rays" each cover a particular aspect of X-ray physics. Copies of the book are available from The Mullard Educational Service, Mullard House, Torrington Place, London WC1, price 2s 6d.

## Two ways to Better Soldering

**I**NSTANT heat—or practically instant heat—is what you get with a new soldering gun made by Burgess Products Co. Ltd. (Electric Tools Division, Sapcote, Leicester), for it takes as little as 5 seconds for the tip of this gun to reach operating temperature.

The tip itself is interchangeable with a wide range of screw-in accessories, including special bits for de-soldering printed circuit components, like miniature i.f.'s, etc. Housed in a flame-resistant casing, the gun is balanced to provide accurate control even with delicate work. A built-in pre-focused light which illuminates the working area of the tip also helps to make soldering easy.

The gun can be bought in a kit for £3 19s 6d for which you get gun, extension barrel, two tips, probe and solder.

Light Soldering Developments Ltd. of 28 Sydenham Road, Croydon, Surrey, have also recently introduced a new soldering development known as "BITLOOS".

BITLOOS is a compound which

provides a remedy for bit seizure in soldering irons which often results in damage to irons when attempting to remove bits which have become firmly fixed after

continued use at high temperature.

BITLOOS forms a heat-resistant anti-corrosion coating on the bit surfaces making removal easy even after long periods.

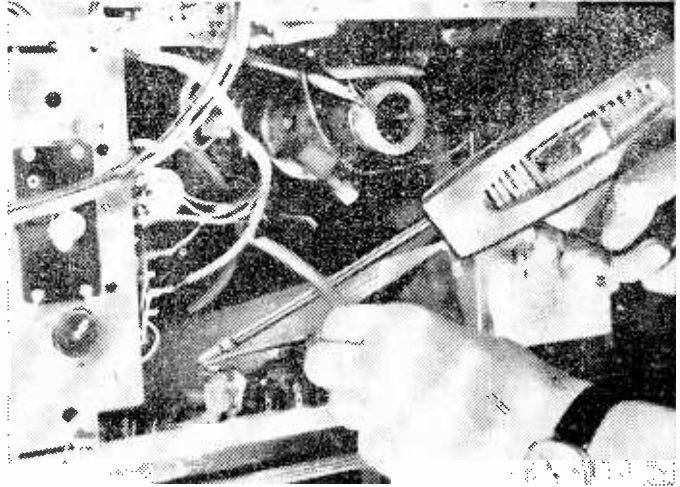

*The new Burgess Soldering Gun in use on a TV chassis. Note how the light beam illuminates the working area around the bit.*

## Colour TV Rekindles Public Interest

**A**T London's recent Ideal Home Exhibition at last, the PMG's statement on colour television seemed to stir the public's imagination. Thousands of visitors to the show crowded round the Baird

Television stand to see continuous live colour transmissions.

The sets demonstrated were prototypes of the ones Radio Rentals and Rentaset will offer on rental towards the end of 1967 when the

BBC will begin broadcasting colour.

Baird plan to start production early in 1967 of colour sets which will cost an estimated £200 or £250. On rental the cost may be between 30s and 35s per week.

### 13 NEW STATIONS IN THREE YEARS

**D**URING the next three years, the Independent Television Authority will build thirteen new transmitting stations, bringing new or improved services to over half-a-million people in western regions.

In Wales, where the mountainous nature of the region restricts television coverage, six small stations will be built to transmit TWW programmes to an area including Abergavenny, Ffestiniog and Llandrindod Wells. The other stations will be built in Scotland and in parts of the west of England where coverage is incomplete.

### NEW STORAGE DARK-TRACE CRT

**F**OR many years STC Components Group has produced a dark-trace cathode ray tube capable of storing oscillographic images for any desired length of time. Now STC has brought out an improved tube—the type AS 17-21 A—which is capable of sustaining a considerably greater erasing frequency than its predecessor.

The new tube is particularly suitable for use in measuring, recording and control instruments.

### SHOP'S NEW TV DEPARTMENT

**S**HOPPERS at Marshall and Snelgrove, the well-known London departmental store, can now see everything that's new in television, radio and hi-fi equipment in a recently opened department.

In amongst the refrigerators and dishwashers on the lower ground floor, the connoisseur and the enthusiast will find TV receivers, record decks, amplifiers, etc., from leading English, Continental, American and Japanese manufacturers.

### TELEVISION SOCIETY LECTURE

**T**HE Television Society held a lecture on Friday 15th April. It was given by W. Silvie, B.Sc., A.M.I.E.E., of Ampex, Gt. Britain Ltd., on Domestic Video Recording.

A survey of Video Recording techniques applicable to the home environment was followed by a description of one typical domestic video recorder now being manufactured.

Complete home television systems and wider applications in the field of Educational television were discussed, with reference to typical installations.

# TESTING TRANSFORMERS WITH AN OSCILLOSCOPE

Finding out whether or not the transformer windings possess 'shorting turns'

by  
K. Royal

THERE is not a great deal of difficulty in determining whether or not the windings of a transformer possess continuity. All that is required for a test of this kind is an ohmmeter or some simple form of continuity tester, applied as shown in Fig. 1.

One may wonder what else, apart from an open-circuit winding, can happen to a transformer. Unfortunately, a number of things can go wrong. For instance, the windings of one coil may short-circuit to the windings of another. This would be caused by the breakdown of the insulation of the wire between the two windings. Again, this trouble can be brought to light by a simple ohmmeter test, as shown in Fig. 2.

A third fault to do with insulation troubles is when the insulation of one (or more) winding

breaks down to the transformer core, and this can be revealed by connecting an ohmmeter or continuity tester in turn from each of the windings to the core, as shown in Fig. 3.

It should be remembered, however, that insulation troubles may develop only when the transformer is subjected to its normal "on-load" conditions, and that checking for leakage or short-circuits with the relatively low voltage given by the average ohmmeter or continuity tester may not always represent a test of conclusive nature.

## Core Fracture

Another fault, that sometimes occurs in transformers with ferrite cores—such as line output transformers—is fracture of the core material. This may only be a hair-line crack, yet it can be sufficient to detract considerably from the performance of the line output stage, which needs to be always working at—or near—maximum efficiency. Thus, anything that reduces the efficiency, even by a small amount, will show up on the line scan. One symptom is reduced width; another poor line linearity (cramping usually at the right-hand side of the picture) and another poor e.h.t. regulation.

Poor e.h.t. regulation is responsible for a picture progressively expanding and *reducing* in brightness as the brightness control is turned up, finally leading to a blank screen at full setting of the control. Note, however, that there are numerous other causes of this symptom. These include the e.h.t. rectifier valve going "soft" or low emission, weakening of the line output valve or booster diode, increase in value of the line output valve screen grid resistor and decrease in value of the boosted h.t. line charging capacitor.

Some early sets were particularly prone to line output transformer core faults, but their modern counterparts exhibit less of this trouble. Nevertheless, if line output transformer trouble is suspected, it is a good idea to scrutinise the core with a magnifying glass to make sure that the core, at least, is in order.

## Shorting Turns

Transformer troubles so far mentioned can be checked relatively easily, but there is one trouble that is far more difficult to check and that is the classic "shorting turns" fault. This is not the fault due to breakdown of the insulation between two separate windings, as this can be checked easily, as we have seen in Fig. 2, but it is the fault of insulation breakdown between adjacent turns *on the same winding*. Thus, the tests so far described fail to reveal a fault of this kind.

If we know or measure the d.c. resistance of a transformer winding, this value would differ insignificantly from that resulting from a similar test but this time with just one or two turns of the winding shorting. The difference in resistance would only be an ohm or so or, perhaps, even less than one ohm!

## Resistance Tolerance

Most service sheets and service manuals give details of the resistance values of the various windings of the transformers used in the set. There is a tolerance on these values, however, and a

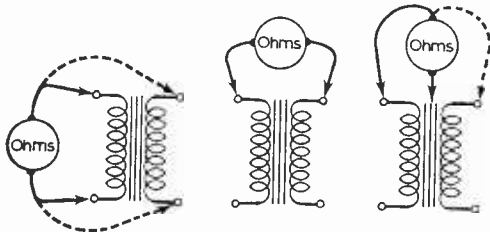

Fig. 1 (left)—Checking winding continuity.

Fig. 2 (centre)—Checking for interwinding shorts.

Fig. 3 (right)—Checking for shorts between windings and core.

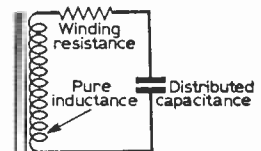

Fig. 4—The composition of an inductor or winding on a transformer.



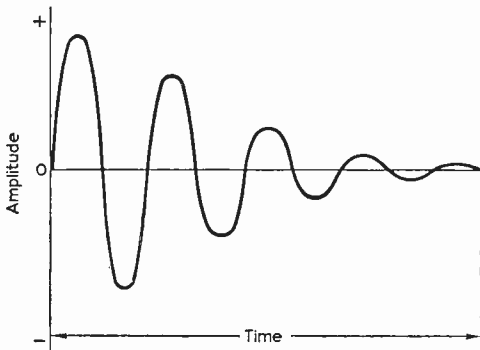

Fig. 5—A damped oscillation. This is fully explained in the text.

minimum tolerance in this respect might be in the order of  $\pm 5\%$ . Thus, if the nominal resistance of the winding is given as, say,  $1,000\Omega$ , its actual value could be anywhere from  $950$  to  $1,050\Omega$ .

If a winding has several adjacent turns shorting, the difference from the nominal value would be only a few ohms, still well within a tolerance of  $\pm 5\%$ . It would be impossible, therefore, to say that the small difference in resistance measured from the nominal resistance as given in the service sheet or manual is definitely due to shorting turns. It could be either shorting turns or tolerance!

If a large number of turns happen to be bypassed by the short-circuit, a relatively large difference from the nominal value would be indicated, and one could then say almost conclusively that the transformer is in trouble.

In television sets, it usually happens that adjacent turns short-circuit, particularly in the line output transformer, so nothing conclusive can be gleaned from an "ohms" check. It is often necessary in a case like this to test the suspect transformer by replacing it with one known definitely to be in good order. Incidentally, the latest idea in design makes for easy removal of the line output transformer for substitution check and replacement.

It is often wondered why a shorting turn or two upsets a transformer—particularly a line output transformer—so much. It is not so much the fact that one or two turns have been effectively deleted from the winding as a whole, but the trouble arises

from the completely short-circuit turn or turns created by the winding short. In effect, the shorting turns produce a separate winding which itself represents a closed loop or winding. It is rather the same as short-circuiting a complete, unused, winding on a mains transformer. The winding which is short-circuited would certainly detract seriously from the normal operation of the transformer on the used windings.

Short-circuit current flows in the shorted winding or loop, and thus power is pulled from the transformer unnecessarily. The transformer efficiency falls badly, and in the line output stage it ceases to work as a transformer under shorting winding conditions.

**Efficiency**

How can transformer efficiency be checked to determine whether or not a short-circuit turn or turns is present? Well, one way of doing this is to apply to the primary winding a voltage from a matching source of frequency over the range for which the transformer is designed, and then to measure the voltage across the secondary winding with an indicating device which is also properly matched to the winding.

If the turns ratio of the transformer is known, then the voltage across the secondary winding should be above, in the case of a step-up ratio, or below, in the case of a step-down ratio, the voltage across the primary winding by the value of the ratio. Thus, if there is a two-to-one step-up ratio, the secondary voltage should be two times the primary voltage. This is assuming 100% efficiency. Actually, practical transformers work at efficiencies less than 100%, but transformers of the nature under consideration have efficiencies of 90% and above.

Mains transformers are easy to test for efficiency by using the mains input at 50c/s (or whatever the mains frequency is) at the primary and an a.c. voltmeter to measure the secondary voltage. Audio transformers need an input signal source, such as from an audio generator, over the audio spectrum and a valve voltmeter or some other sensitive device to measure the secondary voltage.

Shorting turns in a mains transformer result in severe overheating and low heater and h.t. output voltages. In audio transformers the coupling efficiency is considerably impaired, and in speaker and output transformers the bass and treble output is greatly curtailed.

Line output transformers in television sets are designed to operate at maximum efficiency at either 10,125c/s on 405 lines or at 15,625c/s on 625 lines. In fact, these transformers are tuned so that the "loss inductance" resonates to the third harmonic of the line flyback frequency. In dual-standard sets a switched tuning capacitor or extra transformer winding takes care of this.

Clearly, if there are short-circuited turns, the line output transformer is greatly reduced in efficiency. The usual symptom is lack of e.h.t. voltage (hence lack of screen illumination), though the line whistle may be heard if the line hold control is rotated over its range. The presence of line whistle, in fact, signifies that, at least, the line timebase generator is working. Knowing this can be a help in diagnosis.

Now, the windings of transformers have

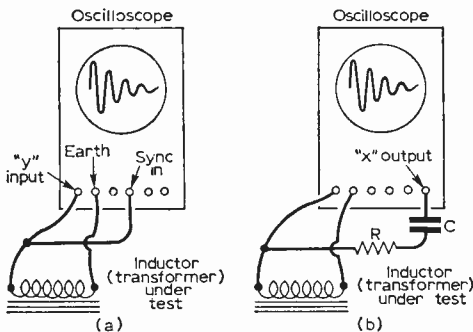

Fig. 6—Two ways of obtaining a "ringing" display on an oscilloscope. (a) Uses pulses from the "sync" terminal and (b) from the "X out" terminal.

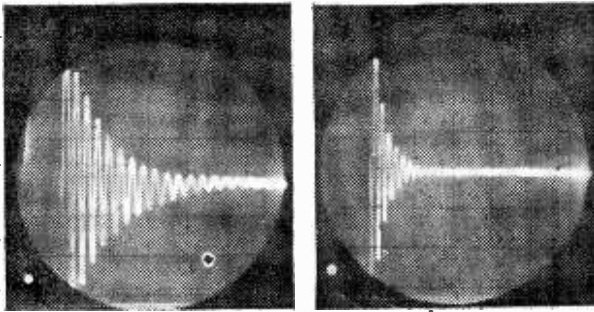

Fig. 7 (left)—Waveform across line output valve anode and booster diode cathode terminals of a line output transformer. No short circuit.

Fig. 8 (right)—Waveform as at Fig. 7 but with shorting turn on the e.h.t. overwind.

inductance, and this is very much affected by the core and by the other windings. The inductance of a winding which is free from fault, for instance, would be greatly reduced by a short-circuit turn in a partnering winding. This means, then, that if the inductance of each winding is known, checking each winding in turn—with the others open-circuit—would reveal whether or not one winding is suffering from a short-circuit. The snags here are (i) the inductance of the windings is rarely known and (ii) even if it is not many enthusiasts, or service technicians for that matter, possess an accurate inductance bridge. Q-meter or inductance measuring instrument to check it.

All inductors, including the windings of transformers, are composed not only of pure inductance, but also of d.c. resistance of the winding and capacitance between the turns. This latter element is called "distributed capacitance" because it is distributed between the turns making up the winding.

In effect, then, we have pure inductance in series with the d.c. resistance and in parallel the distributed capacitance. This can be represented by a circuit such as that in Fig. 4.

#### Natural Frequency

This is a "tuned circuit", and the tuned or

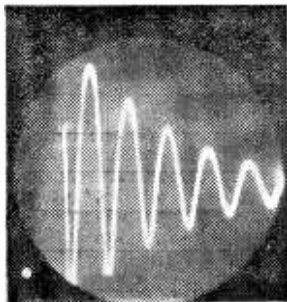

Fig. 9—Waveform across a small h.f. choke with ferrite core.

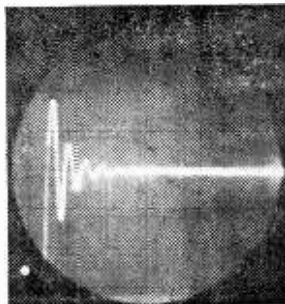

Fig. 10—Waveform as at Fig. 9 but with a winding of four turns shorted.

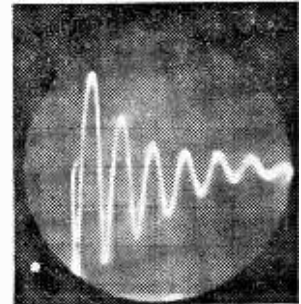

Fig. 11—Waveform across anode of e.h.t. rectifier valve and cathode of booster diode. No short circuit.

"resonant" frequency is given by the inductance and capacitance in the ordinary way. The "natural" frequency of the circuit depends on the winding, make-up. It is possible to get this winding to "oscillate". There are various ways of doing this, one by connecting the winding to an oscillator valve or transistor circuit and another by "pulsing" the circuit so that it "rings" or oscillates at its natural frequency.

This can be likened to plucking the string of a musical instrument. The string in a piano, for example, will oscillate at its resonant or natural frequency when struck by the key hammer. Here, the resonant frequency is given by the length, diameter, tension etc. of the string. Strings of this kind are tuned by tensioning to produce the required audio note.

The effect is that the string initially vibrates (i.e., oscillates) vigorously when struck, the vibrations or oscillations gradually decaying to nothing. This is a "damped oscillation", and can be represented by the waveform in Fig. 5. The frequency remains constant but the amplitude of oscillation gradually tails away until it becomes quiescent after time period (t).

#### Damped Oscillations

As with the instrument string, so it is with a tuned circuit, but here the oscillations are given by the oscillatory movement of electrons in the circuit, first one way on one half-cycle and then the opposite way on the other half-cycle. It is possible to "see" these electronic oscillations on the screen of an oscilloscope by connecting the inductor across the 'scope's "Y" input terminals and then arranging for the tuned circuit to be electrically "plucked".

This "plucking" can be achieved by electrical pulses being applied to the tuned circuit (i.e., inductor in this case) at the instances when the spot on the tube face is changing rapidly during the retrace from the right to the left-hand side of the screen. Actually, during these periods the spot is generally "switched off" due to a beam suppressing action activated by the circuits within the 'scope. Nevertheless, the retrace action of the 'scope's "X"

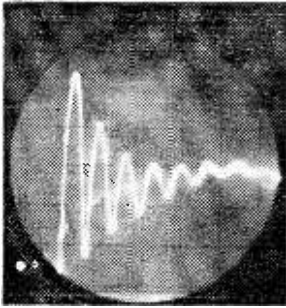

Fig. 12—Waveform as at Fig. 11 but with half the line scanning coils shorting.

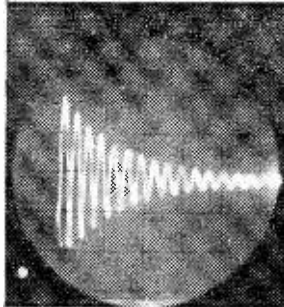

Fig. 13—Waveform across the line scanning coils. No short circuit.

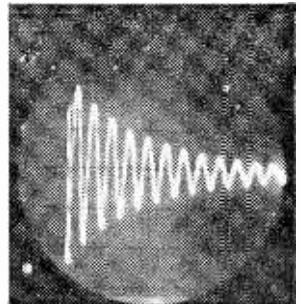

Fig. 14—Waveform across the field scanning coils. No short circuit.

timebase gives rise to pulses that are ideal for so-called "plucking" the tuned circuit.

Now, these "plucking pulses" can be obtained either from the "sync input" terminal or the "X out" terminal on the 'scope, and they are then conveyed to the tuned circuit (inductor) under test. The set-up is shown in Fig. 6, at (a) when the "sync input" terminal is used and at (b) when the "X out" terminal is used.

The capacitor C and resistor R in series with the "X out" lead at (b) serve respectively to isolate the timebase from the inductor and to prevent excessive damping of the effective tuned circuit by the timebase. The capacitor should have a value around 1,000pF while the best value for the resistor is found by experiment. The author has used a 4.7k $\Omega$  with success. The oscillogram in Fig. 7, taken direct from the screen of an oscilloscope, reveals what was actually obtained by the author with the "Y" input of the 'scope connected between the anode of the line output valve and the cathode of the boost diode (i.e., across the main primary winding of the line output transformer) and with the "plucking pulse" obtained from the "X out" terminal, as in Fig. 6 (b).

In fact, all tests made by the author were found best by using the Fig. 6 (b) configuration. The author's 'scope delivers insufficient "plucking signal" at the "sync input" terminal. Some 'scopes, however, provide an adequate signal at that terminal, depending on the design.

### Ringling Waveforms

For Fig. 7, the "Y" input was set to 3V/cm, the waveform thus showing an overall maximum amplitude of 18 volts peak-to-peak (i.e., measured by the six 1cm squares on the 'scope graticule). The sweep was set to 30 $\mu$ S/cm, and since the waveform shows three complete cycles of oscillation for every 1cm square of the graticule, one cycle of oscillation takes 10 $\mu$ S. This means that the resonant or natural frequency of this particular winding is about 100kc/s. Why this is so is because the frequency in kc/s is equal to 1/ the time of one complete cycle in mS, giving 1/0.01, or 100kc/s.

All this is very academic, but how on earth can it help us to tell whether a transformer (or inductor) has shorting turns or not? Well, as we have already seen, shorting turns act as a severe damper on the transformer; rather like the "soft pedal" being

applied to a piano. Thus, when a short is present in a winding the oscillatory train decays more quickly than when the winding or a winding is free from a short-circuit.

Look at the oscillogram in Fig. 8. This shows the waveform from the same transformer but this time with the e.h.t. overwinding having a short-circuit turn. The "Y" input is set to 1V/cm, giving an overall maximum peak-to-peak amplitude now of only 6 volts, as distinct from 18 volts in Fig. 7. The biggest aspect, however, is the speed at which the waveform train decays to zero.

Fig. 9 shows the waveform obtained from a small h.f. choke with a ferrite core. Fig. 10 shows the waveform from the same choke but this time with four turns wound round the core and short-circuited! The "Y" input in each case was 30V/cm and the sweep 10 $\mu$ S/cm. The damping effect due to the shorting turns is clearly seen.

Fig. 11 shows the waveform obtained between the anode of the e.h.t. rectifier valve and the cathode of the boost diode (the primary of the line output transformer, including the e.h.t. overwind) with the "Y" input at 30V/cm and the sweep at 30 $\mu$ S/cm, while Fig 12 shows the waveform across the same windings but this time with half the line scanning coils shorting. The sweep is unaltered here, but the "Y" input is reduced to 3V/cm. Thus, the scanning coil short has damped out the oscillation a little towards the end and considerably reduced its amplitude.

Fig. 13 shows the waveform obtained from across the line scanning coils ("Y" input 10V/cm and sweep 30 $\mu$ S/cm), while Fig 14 shows the waveform from across the field scanning coils ("Y" input 30V/cm and sweep 100 $\mu$ S/cm).

These oscillograms reveal conclusively the value of an oscilloscope for short-circuit testing in transformers and inductors. For the service technician, the best plan is to obtain such waveform statistics from line, field and audio transformers and scanning coils when the set is working correctly, and then they are available for comparison should a set come in for service with suspect transformer or scanning coil trouble.

For the enthusiast with an oscilloscope, detailed analysis of the experimental and domestic set can be made relative to all inductors and transformers, then should anything go wrong, very valuable information is at hand for comparison of "ringing" waveforms. ■

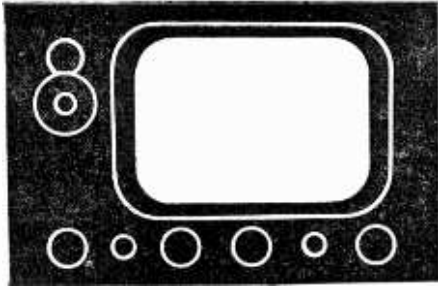

# THE OLYMPIC II

## Transistor TV

### — A NEW LINE SCAN STAGE

by D. R. Bowman, B.Sc.

SINCE the publication of the constructional data of the *Olympic II* during 1965, work has continued on improvements to what experience has shown to be a reliable receiver. The original circuit for the line-scan unit proved to have a relatively minor defect in that until the blocking oscillator transistor had reached a stable working temperature there was a slight drift of operation which necessitated the readjustment of the line hold control. After about fifteen minutes operational stability was reached, but this characteristic was considered undesirable and steps were taken to correct the fault.

Readers will be interested to note that this drift should have been correctable perhaps by increasing the gain in the feedback loop. The ability of negative feedback to correct for amplitude distortion is well known, but it may be less widely recognised that if frequency can be related directly to a voltage or current, negative feedback can correct for changes of frequency also. This is what is done in effect when an error signal (an "off-frequency" voltage) is used to afford automatic frequency control in v.h.f./f.m. tuners. However, it proved rather difficult to obtain enough gain in the feedback loop without running into problems of drift in the d.c. amplifier itself. Here, not only was transistor junction temperature one cause, but also variations in the ambient temperature. Low-leakage silicon transistors might have proved to be the answer to this problem, but these are expensive if of the required quality.

In electronic engineering there is usually more than one way to produce a desired effect, and in fact the straightforward way sometimes turns out to be hopelessly clumsy—especially if it results in complication or the use of highly specialised components. In tackling this problem it proved to be more elegant to return to first principles. Here was an oscillator which tended to drift in frequency; could one be found which was inherently stable? One of the reasons for rejecting the multivibrator as line oscillator had been its voltage and temperature dependence. While the blocking oscillator was better in these respects, and had also the advantage of rather easier 625-line conversion, it was still not good enough. The question seemed to be whether a tuned oscillator—using the highly stable L-C circuit—could fill the bill. It certainly seemed logical to approach the task from this angle.

Since the transistor is essentially a current-operated device, there is no real possibility of being able to couple it to a tuned circuit as lightly as a vacuum tube can be coupled. Unless a transistor circuit of very high input and output impedances could be devised, the transistor would load the tuned circuit heavily, so reducing its Q and so, the inherent frequency stability. An input emitter-follower might precede the amplifier, and an emitter-follower after the amplifier would complete the circuit. This would have three transistors, and still be inferior to a single pentode.

However, a transistor need not be used as a

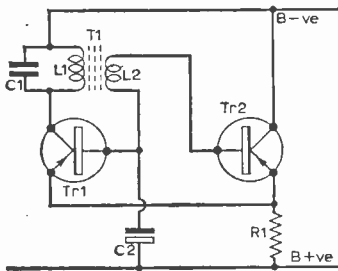

Fig. 1 (left)—Simplified oscillator circuit.

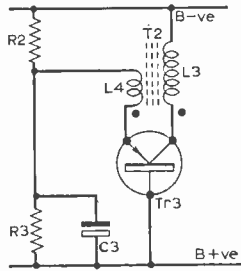

Fig. 2 (centre)—Simplified blocking oscillator circuit.

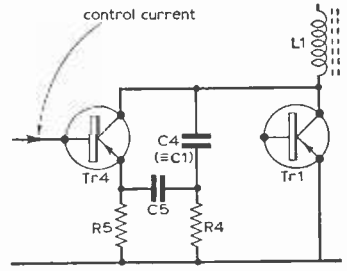

Fig. 3 (right)—Circuit of the resistance transistor.

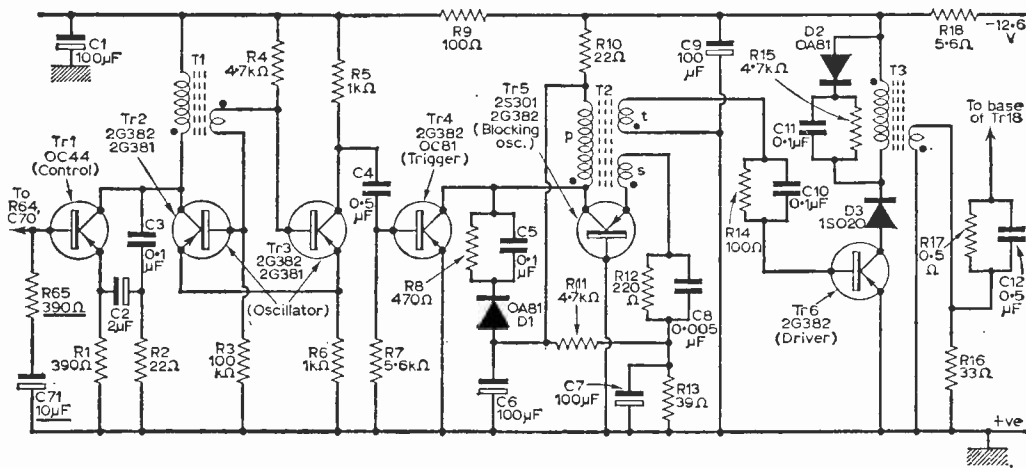

Fig. 4—Revised circuit of the line-scan stage.

linear amplifier to maintain oscillation; it can be used as a switch to feed extra energy into a tuned circuit to make good the losses. Using the transistor in this way goes as it were to the other extreme and couples it to the circuit very tightly. However, ideally the transistor is cut off completely or else is hard on in this mode of operation, and so ideally takes the place of a switch either open or closed. It does not (ideally!) load the tuned circuit at all, since it is in series with the tuned circuit, not in parallel. It need hardly be said that this is the ideal case. In practice, the tuned circuit has to supply some power to the transistor base to make it switch. If, however, the transistor circuit is highly regenerative of itself, the tuned circuit need only supply a trigger pulse at the moment of switching; the "duty cycle" will be small and the effect on frequency negligible.

The circuit used is shown in simplified form in Fig. 1. It consists of two transistors arranged in the "long-tailed pair" configuration, familiar to experimenters in the form of the cathode-coupled multivibrator using valves. Instead of a resistor in one collector circuit, there is the tuned circuit, and instead of cross-coupling by means of a capacitor, this is effected by a small winding coupled magnetically to the tuned circuit. In operation, current is switched alternatively to one or the other transistor, and hence a rectangular current wave is supplied to the tuned circuit—just as if it were alternatively switched mechanically to a source of power.

Readers will note that in Fig. 1 no d.c. bias supplies are provided, but if this be done (by a resistive network attached to one base) and a simple working circuit hooked up for experiment, the circuit is easy to get going, and very reliable in operation. It is instructive to connect an oscillator across the tuned circuit L1-C1 and to observe the wave-form resulting. It is a very pure sine wave, if the Q of the tuned circuit is reasonably high; just the kind of wave-form desired by tape-recordists for bias or erase.

For the present purpose, however, the

important feature is that in the calculation of frequency, transistor parameters enter into the result to only a very small extent, showing that the frequency is dependent almost entirely on the tuned circuit. Thus, there is here a very stable "clock" mechanism which should be highly suitable for a line oscillator.

If this tuned circuit waveform were used to drive the scanning stages direct, however, quite a heavy load (transistor-dependent) would be imposed on it, and much would be lost. As it happens, one does not need to do this. If a small resistance is connected in Tr2 collector lead the rectangular current pulse through Tr2 will develop a rectangular voltage wave-form across it. This may also be observed readily on an oscilloscope. This pulse could be amplified and used direct to drive the scanning stages. It does suffer however from having a relatively slow rise-time (although probably fast enough) and is of equal "mark" and "space" periods. This would probably do quite well, but the present design is arranged to make matters technically correct and not to be effective with certainty. Consequently this pulse is used to trigger a one-shot blocking oscillator using a ferrite component as the feedback transformer, whose pulse duration and rise-time are amenable to separate function design. This in turn drives a driver stage, which operates the output device.

### The blocking oscillator

The blocking oscillator is shown in simplified form in Fig. 2 and will be seen to be an emitter-coupled blocking oscillator. It is arranged not to be free-running; since the base of Tr3 is held positive to the emitter, the transistor is held in the cut-off state. When a trigger pulse is applied to the emitter (a positive pulse is required) or to the collector (a negative pulse) i.e. the base momentarily becomes negative with respect to the emitter and the transistor enters the "active"

region of operation. Provided the pulse is of sufficient amplitude to do this, and is of long enough duration, regeneration takes place and the oscillator "fires", producing a pulse whose characteristics depend on the core material of T2 and the nature and disposition of the windings thereon. In the circuit actually used the rise-time of the pulse is of the order of  $0.75\mu\text{s}$ , and though this performance is degraded by the subsequent driver stage, the pulse edges are very sharp and of very good amplitude—about  $1\mu\text{s}$  rise and fall time. The output transistor is thus switched very rapidly and spends little time in the "active" switching region; thus it dissipates little and safety is assured.

The remainder of the circuit-driver and output transistor are as in the *Olympic II* and need no further mention. The flywheel sync will therefore be described next. The essential circuit for the sync control is that of the reactance transistor, and is shown in Fig. 3. Considering the tuned circuit of Fig. 1, the capacitor C1 is replaced by C4 and R4 in series. R4 is very small compared with the reactance of C4, and thus a voltage is developed across it which is essentially in quadrature with that across the tuned circuit. This voltage is applied to the emitter of Tr4, via the capacitor C5, and is amplified by Tr5 acting as a grounded-base amplifier. Thus the transistor Tr4 acts as a reactance, and placed across the tuned circuit, can alter the frequency of operation. The amplifica-

tion of Tr4 is dependent on the transistor working point, and thus if the control current into the transistor base changes, so does the frequency of oscillation.

The above circuit is so arranged as to utilise the control current from the *Olympic II* sync unit, with a very small modification. This consists of the following, referring to *Practical Television*, September 1965, page 555, Fig. 33.

- (a) Remove R100
- (b) Connect VR12 "lower" end to +ve rail
- (c) Disconnect VR12 "upper" end from VR11
- (d) Between VR12 and VR11 connect  $470\Omega$  resistor.

This change is necessitated by the fact that the "control" transistor (Tr4 in Fig. 3) is operated with the emitter at a somewhat more positive (earthy) potential than is Tr15 in Fig. 19 of the *Olympic II* series (July 1965, page 449). If desired, resistors R98 and R99 can be reduced from  $10\text{k}\Omega$  to  $6.8\text{k}\Omega$  with some improvement in sync stability.

Two components in the base circuit of Tr15 (Tr1 in Fig. 3 above) are altered as follows:—

- R65—delete  $3.9\text{k}\Omega$  substitute  $390\Omega$ .
- C71—delete  $0.5\mu\text{F}$  substitute  $10\mu\text{F}$  15V wkg electrolytic (+ve end to +ve chassis).

The above description should give a reasonably clear idea of the principles used in the new circuit.

The complete circuit is shown in Fig. 4, and this replaces much of the circuitry of Fig. 19 (July 1965). The network R77, C78, C84, C69, C70 and R64 remain, but are not shown in Fig. 4, and the present circuit ends at the dotted line near R74. C82 and C77 remain however.

The suggested printed circuit of Fig. 5 replaces in *1010 PC4* in the July 1965 issue. Owing to the different arrangement of the components, and their greater number, it will be necessary to re-locate the studs on which the circuit board is mounted inside the screening can of perforated zinc.

Apart from the small components, many of which can be used from the original PC4, the following major components can be re-used.

- (a) Driver transformer T6 intact.
- (b) T5 as it stands, with an additional winding of 60 turns 32 s.w.g. enamelled copper wire close-wound. This is the tertiary, for coupling to the driver transistor Tr6. It should be noted that in connecting this transformer into the present circuit, the

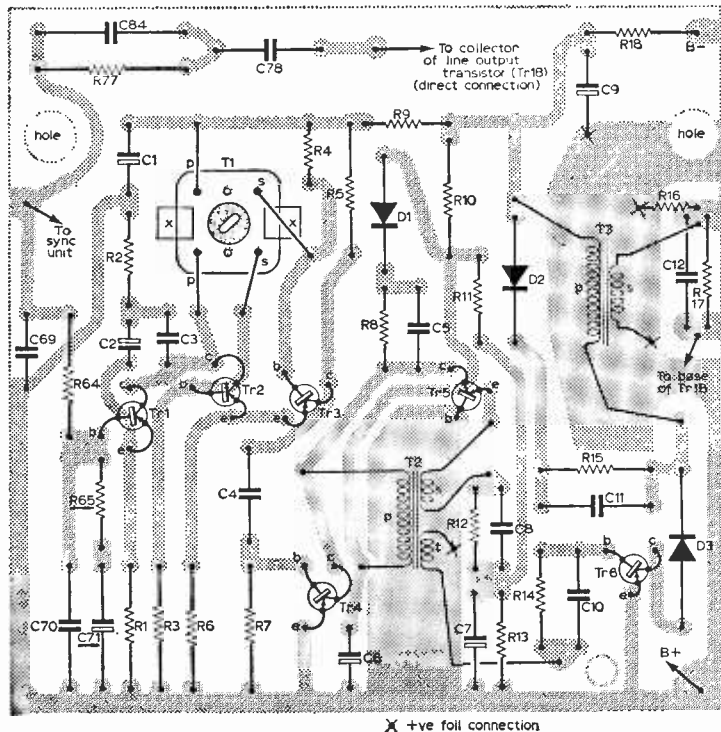

Fig. 5—Printed circuit layout.



end of the secondary winding previously connected to the transistor base now goes to the junction of R2 and R3 (in Fig. 2 above)—the resistors are 4.7k $\Omega$  and 39 $\Omega$  respectively. The other end of this winding goes to the emitter of Tr5 in Fig. 4, via 220 $\Omega$  and 0.005 $\mu$ F in parallel.

- (c) Diodes 1S021 and two OA81's.  
 (d) " 2S301 (now becomes blocking oscillator Tr5)  
 (c) " 2G382  
 (f) " OC81 (now becomes trigger transistor Tr4).

In addition the 10kc/s oscillator transformer, with screening can, is required (Denco, Type 9A), together with two more 2G381 or 2G382 transistors and an OC44 as the control (reactance) transistor. Thus all the expensive items are re-used.

It will be noted that the long-tailed pair oscillator does not have an electrolytic capacitor between one base and "chassis"! The use of this would entail the working voltage not being reached for a second or two. Entirely satisfactory results arise from relying only on the intrinsic base-to-emitter capacitance of the transistors, no physical components being required.

### Setting-up

When completed, setting-up is a simple matter. In preliminary tests, before wiring into the receiver, the frequency should be set up (preferably by using an oscilloscope display, but by ear if no oscilloscope is available), with a 680k $\Omega$  resistor wired between the base of Tr1 and the -12.6V rail. This simulates the actual control current supplied by the sync unit. The frequency of oscillation is adjusted by rotating the core of the transformer T1. This consists of the Denco unit (in screen) wound with 350 turns of 42 s.w.g. enamelled copper wire (collector), 1 layer of 0.001in. paper, then 75 turns of the same wire for the base connections of Tr2 and Tr3. It may be found difficult to get on all this wire, unless wound very carefully, as the winding can only be 5/32in. in length and the ferrite cup must not chafe it when pushed into position. If this is found hard to comply with, fewer turns may be put on (proportionately in base and collector windings) and the tuning capacitance increased from 0.1 $\mu$ F to perhaps 0.15 $\mu$ F. Alternatively, 44 s.w.g. wire will easily fit the space available. The two "anchors" shown on the printed circuit are for soldering the securing pins of the screening can.

### Heat Sinks

The only transistor requiring a heat sink is the driver Tr6, and even this is hardly necessary. About two or three square inches of aluminium sheet will do quite well. In the prototype such a small sheet was fastened to the clamp of the driver transformer T3 by means of "Araldite" resin. Alternatively, a small finned cooling clip would serve quite well and would need no support. The silicon transistor runs quite cool and needs no cooling device.

## ★ components list

### Resistors:

R1	390 $\Omega$	R11	4.7k $\Omega$
R2	22 $\Omega$	R12	220 $\Omega$
R3	100k $\Omega$	R13	39 $\Omega$
R4	4.7k $\Omega$	R14	100 $\Omega$
R5	1k $\Omega$	R15	4.7k $\Omega$
R6	1k $\Omega$	R16	33 $\Omega$
R7	5.6k $\Omega$	R17	0.5 $\Omega$
R8	470 $\Omega$	R18	5.6 $\Omega$
R9	100 $\Omega$	R65	390 $\Omega$ (previously 3.9k $\Omega$ )
R10	22 $\Omega$		
All 10% $\frac{1}{2}$ W			

### Capacitors:

C1	100 $\mu$ F 15V electrolytic
C2	2 $\mu$ F 15V electrolytic
C3	0.1 $\mu$ F paper
C4	0.5 $\mu$ F paper
C5	0.1 $\mu$ F paper
C6	100 $\mu$ F 15V electrolytic
C7	100 $\mu$ F electrolytic
C8	0.005 $\mu$ F paper
C9	100 $\mu$ F electrolytic
C10	0.1 $\mu$ F paper
C11	0.1 $\mu$ F paper
C12	0.5 $\mu$ F paper
C71	10 $\mu$ F 15V electrolytic (previously 0.5 $\mu$ F)

### Semiconductors:

Tr1	OC44, Tr2	2G382	2G381, Tr3	2G382
2G381, Tr4	2G382	OC81, Tr5	2S301	2G382,
Tr6	2G382, D1	OA81, D2	OA81, D3	2S02P.

### Transformers:

T1	core, Denco type 9A, primary 350 turns, secondary 75 turns, both 42 s.w.g. enam. copper wire.
T2	as T5 (page 488 P/TV Aug. 1965) but with tertiary winding added (see text).
T3	as T6 (page 488 P/TV Aug. 1965).

### Check with thermoammeter

When the unit is installed, a check should be made with a thermoammeter in series with the base of the line output transistor, as was scheduled in the *August 1965 Practical Television*, page 486 (k); about 0.5A should be obtained, perhaps 0.6A. If less than 0.45A, reduce the base series resistor a little; if more than 0.6A the value of the resistor can be increased a little although this is hardly necessary and a "high" reading is to be preferred. If an oscilloscope is available a good rectangular wave should be obtained between the base and "chassis" with fast rise time. If the rise-time exceeds 2.5 $\mu$ s, something is wrong and the output transistor should not be switched on until the trouble has been found. If no oscilloscope is to hand, put a 2 $\Omega$  variable resistor in series with the battery -ve lead to the scan coils, and an ammeter in series with the battery supply to the stage. On switching on, the reading with the oscillator and driver unit should be 95-110mA, and when the output transistor is switched in, the meter should read about 0.6A in all. The output transistor should *not* get noticeably warm after 5 minutes. If all seems well the resistor may be shorted out progressively and the ammeter reading should *decrease* so that when completely shorted out the

—continued on page 370



# Servicing TELEVISION Receivers

## No. 123 Defiant 9A30 and associated Pageant models continued

by L. Lawry-Johns

**I**T is in the timebases the majority of troubles which do occur will be found. Dealing with the field (frame) timebase first, the common faults are as follows:

### Lack of Height

If this is more severe at the bottom, the top appearing to be extended in relation to the bottom attention is directed to C76  $200\mu\text{F}$  particularly if the fault appears suddenly. If the fault develops

over a period of time the 30PL13 valve V8 is the more likely suspect. A less likely suspect is the screen decoupling  $16\mu\text{F}$  C73C. Severe foldover at the bottom may be due to V8 developing grid-cathode leakage or to C77  $0.01\mu\text{F}$  or C80  $0.1\mu\text{F}$  becoming leaky. Inability to lock the frame or persistent variation of the hold control setting should again direct attention to V8 although the control itself—VR4  $330\text{k}\Omega$ —could be at fault. Weak frame sync with the picture tending to roll either up or

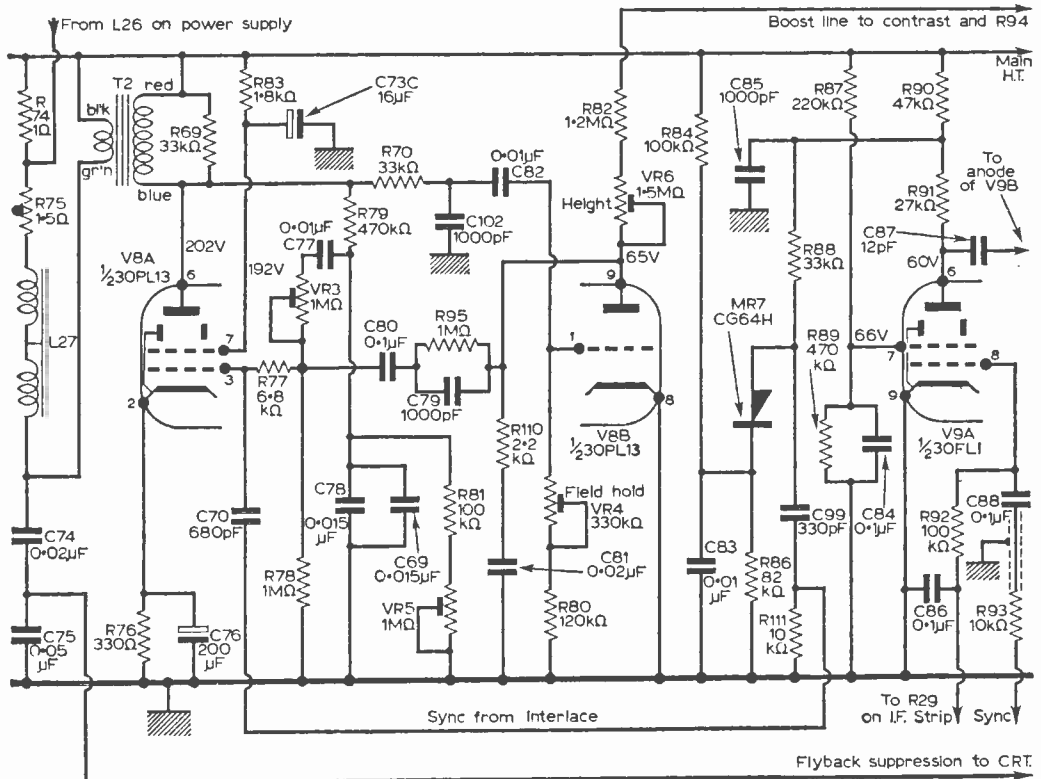

Fig. 5—Field timebase circuitry.





SERVICING TV RECEIVERS

—continued from page 352

though the valve heaters are glowing normally. This indicates a fault in the h.t. circuit and attention is directed then to the dropper sections which supply the metal rectifier MR6 (HT5) and the rectifier itself.

No Sound

The audio-output 30PL1 is at the top left side as viewed from the rear. Quite often complete absence of sound is due to a fault in this valve. A PCL83 can be used as a substitute if a 30PL1 is not to hand. Distorted sound is sometimes due to this valve developing grid-cathode leakage, and it is advisable to check the 470Ω bias resistor R48, if overheating has been taking place. Distorted sound does not have to be in the output stage however, and R44, 5.6MΩ, should be included in any check for distortion. Bridging with a known good resistor of between 1 and 5MΩ, the value not being critical for test purposes, will quickly establish if this resistor is at fault. To revert to the output stage for a moment, severe distortion and overheating of the 30PL1 is often caused by leakage in C56, 0.01μF, which causes the grid (pin 9) to become positive. This causes excess current to flow and the cathode voltage at pin 7 to rise well over the normal 11.5V.

V5 Overheating

If the video amplifier glows due to the grid becoming red hot, the fault will nearly always be found in the vision i.f. stage, V4. The 0.002μF decoupling capacitor, C34, from pin 8 to chassis, is usually at fault.

PRACTICAL WIRELESS  
JUNE

FREE inside next month's issue

24-page Pocket Guide to Transistor Circuits—  
Another in the *Practical Wireless* circuit series.

ALSO IN THIS ISSUE:

- ★ Sub Miniature 300mW Amplifier.
- ★ "Imperial" 3-band Transmitter.
- ★ Transistor Set Booster.

On Sale 5 May – 2/6

**NEXT MONTH IN**  
**Practical TELEVISION**

**IDEAS FOR AMATEUR TV**

First of a great new how-to-do-it series on amateur TV. Shows how to plan your own TV studio, with details of typical equipment.

**ADD-ON SYNC  
CANCELLED AUTO-GAIN UNIT**

A useful add-on unit that will improve your set's low-key contrast and eliminate annoying 'white screen' between scenes. Full construction and fitting details.

**SERVICING WITHOUT A MANUAL**

How to diagnose 'outside' TV set faults quickly with minimum reference to service sheets.

**PIN-POINTING THE TROUBLE AREA**

How to locate the stage or circuit responsible for a fault condition, with the minimum of test equipment.

Order your copy on the form below

TO.....  
(Name of Newsagent)

Please reserve/deliver the JUNE issue of  
PRACTICAL TELEVISION (2/-), on sale May  
19th and continue until further notice.

NAME .....

ADDRESS .....

.....

by Charles Rafarel

---

# DX

**A**FTER the somewhat discouraging news last month I am pleased to report that DX conditions have improved. We are, of course, still early for any real Sporadic E openings of value and as yet only getting a foretaste of what we hope will be the "shape of things to come".

Sporadic E has improved a little but the most significant improvement has been in Tropospheric propagation, where Bands I, III and u.h.f. have been much more rewarding.

## CONDITIONS

Firstly, Sporadic E. Almost every day throughout the period there has been some activity on Band I, though results have been somewhat patchy throughout the country, dependent on the location. The following countries have been quite well received: Austria, Czechoslovakia, Sweden, Switzerland and Denmark.

The star performers seem to have been Austria and Sweden, so this is at last a reasonable improvement and when next month's article appears we really ought to be all much happier.

Secondly, the Tropospherics have shown a general improvement too and from my own area French TV has been coming in strongly from very many stations on all bands, including u.h.f.

Further north and east we have reports of Sweden, Holland and Belgium in Bands I and III and on u.h.f. from some of the eastern French stations as well, so with the more settled weather and high barometric pressure we have been helped at last.

## NEWS

The big news, particularly for u.h.f. DX-ers in Southern England, is that ORTF2 (Brest Roc Tredudon) is now operational on Ch. 21. This is now putting a very good signal at times into my area, so I hope that other DX-ers in the south who have been wondering for so long whether it was operational now know for themselves.

I am still awaiting confirmation as to whether Rennes St Pern, Ch. 45, went into service at the same time. No sign of it here as yet but has any DX friend any comment to make on reception?

Another item of news from **Roger Bunney**:

(1) M.T. Hungarian TV has no programme transmissions on Mondays as the station is closed for maintenance. Whether this precludes the transmissions of test cards we do not know but, if not, the reception of a test card during the evening

should at least help somewhat in clearing up the vexed question of distinguishing between Poland and Hungary, which now use similar cards.

(2) Bad news. We now know that Morocco is not on Band I as previously suggested but in fact transmits on 163.25Mc/s in Band III.

(3) Good news. Canary Islands Tenerife is operating with 300kW on Ch. E3 horizontal. Although the distance is about 1,800 miles we have a chance here.

## IMPORTANT NOTICES

Since we offered to give advice on possible conversions of existing British 405-line sets to 625/819 positive and negative image reception we have been just flooded with requests for information!

*Please note that you must enclose the service sheet with your request as mentioned many times before. With so many types of old and new sets in existence, without the appropriate service sheet the position is impossible.*

So I am sorry but unless your request is accompanied by the service sheet I will be unable to help and will concentrate on cases where I have the necessary information.

We have also been receiving a vast mail from would-be DX-ers asking what the subject is all about! It is, of course, impossible to reply fully in the form of a letter but it has been decided to run a separate series of short articles to explain once again all the basic principles. The first of this series will appear shortly.

## READERS' LETTERS

**D. Boniface**, of Ripon, has again been active on all bands with recent reception of E6 Smilde, Holland, E8 and E10 Wavre and E3 Leige, Belgium, also Lille, France, F8a and Ch. 27.

**I. Beckett**, now at Chackmore, Bucks. (new address), reports ORTF2 Nancy Ch. 23, Aachen, West Germany, on Ch. 24, and a very interesting query ORTF1 on Ch. F4 with aerial towards Lille, the question being whether this is Boulogne (200W only).

**R. Bunney**, of Romsey, has turned in some photographs of BBC taken at Truro, Nova Scotia, during an F2 opening in about 1958. These photographs are most interesting as they show clearly the characteristic multi-path "smearing" associated with F2 propagation.



## DATA PANEL-10

## EAST GERMANY

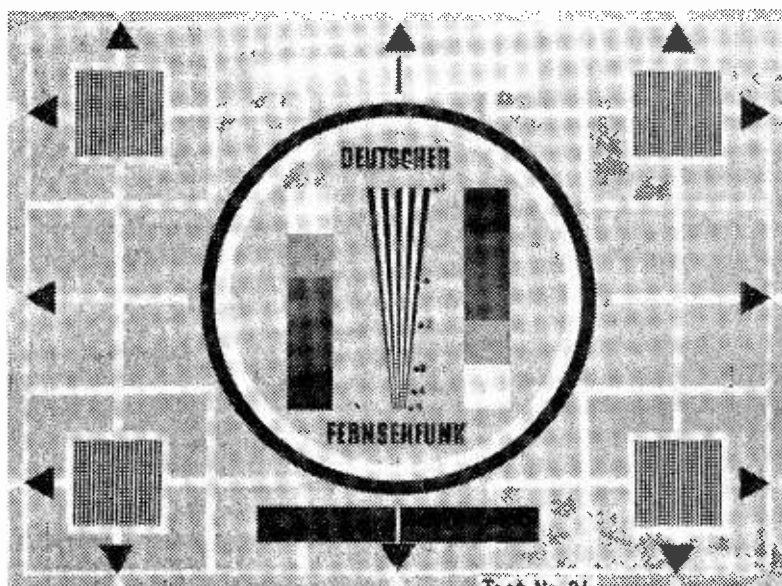

(courtesy M. Aisberg)

**Test Card:** As photograph above. There is also a card in use of a test grid with graduated shaded centre horizontal bands two squares wide.

**Channels:** East Germany operates on two channels in Band I—

- (1) E3, Helpterberg 10kW horizontal. Very often well received here.
- (2) E4, Cottbus 10kW horizontal. Somewhat rarer than the E3 channel.

On Band III there are a number of transmitters and among these the following have

been received with varying degrees of success:

- (3) E5, Inselberg 100kW horizontal.
- (4) E6, Brocken 100kW horizontal.
- (5) E9, Leipzig 100kW vertical.

The easiest to receive is Brocken.

On u.h.f., the only report known is reception of Dequede on Ch. 21.

**Times:** We have no reliable information on test card and programme times, but the matter is being investigated and we hope to have some information before long.

### BBC USE COMPUTER DISPLAYS FOR KEY ELECTION RESULTS

Viewers watching election results on BBC Television the other week were able to see one of the fastest data displays in the world in action. The Marconi tabular display, which can "write" up to 50,000 letters or figures in a second, flashed key results onto the television screen almost as soon as they arrived.

This display system was designed as a fast, plain-writing output for computer controlled defence radar systems, but it has since found many other applications. On election night, the displays were fed from punched paper tape and displayed vital results coming in by telephone and teleprinter from all over the country. Tapes were prepared, on a Marconi computer, to cover every possible result in some 150 key constituencies.

Within seconds the actual figures were added, and the tape fed into a high-speed tape-reader. The result was then written immediately on the tabular display itself

Three displays were used. Each one looks rather like a very small television set, but the displayed information is actually written on the tube face by an electron beam which traces the outline of each letter, rather than by a television scanning system. Marconi television cameras were permanently focussed into each display, to provide a picture suitable for transmission as part of the programme.

The Marconi Outside Broadcast Unit also played a part in the BBC plans for massive Election coverage. The entire Marconi O.B. staff and every available camera were in use, covering four separate outside broadcasts.

### UNDERNEATH THE DIPOLE

Due to the illness of our friend ICONOS there is no Underneath the Dipole this month. We are pleased to say, however, that ICONOS is now recovering and hopes to be back with us in the June issue of PRACTICAL TELEVISION.

# LC

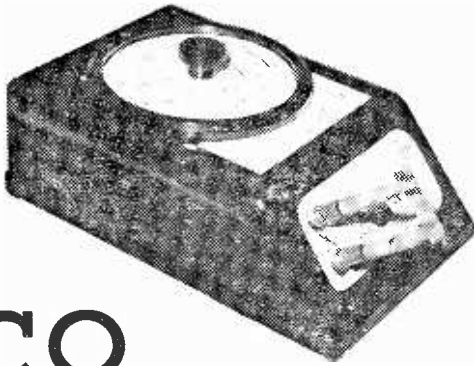

Designed  
and  
Described  
by

Martin L. Michaelis M.A.

# PICO

# METER

## PART 2

THESE effects are minimised by (wherever possible) having *no* part of the picometer circuit earthed and by keeping the hands on the picometer tuning knob in the same orientation for both readings. Hand-capacitance effects are definitely unnoticeable when measuring capacitances greater than 0.7pF in the prototype.

It is essential to use a high-stability tuning capacitor and good slow-motion dial free of backlash if measurements are to be reliable below 1pF. Temperature coefficients are less important, since they are cancelled when establishing resonance at the zero setting in the first place.

### Inductance Measurements

The tuning capacitor of the picometer carries other scales which are intended for direct readings of small inductances. The prototype was provided with just two of these scales, with markings 1.2 to 6.0 and 6.0 to 30 respectively. The units thereby represented, i.e. whether  $\mu\text{H}$ , tens of  $\mu\text{H}$ , mH, etc. (range factors) are determined by suitable choice of the *fixed* frequency setting of the dipper for each range. The range frequencies to make the scale calibrations and decimal multiples or sub-multiples thereof cover the entire range from 0.12 $\mu\text{H}$  to 6mH are marked on the tuning dial.

To take a reading, connect the unknown coil to the "X" terminals and turn the function switch to disconnect the ferrite rod aerial. Then tune the dipper to the spot frequency for the range in which the expected inductance value lies, and apply the probe coil to the unknown coil. Now adjust VC1 on the picometer until dip is obtained, whereupon the inductance value can be read off directly on the appropriate scale.

If the coil is a multi-layer type, or if it has a substantial ferrite or other core apart from a hollow insulating former, its self-capacitance may be appreciable. In this case, *first* measure the self-capacitance as described below. Then, when the resonance point has been found during inductance determination, take a reading on the capacitance ( $C_x$ ) scale and advance to a new reading on this scale greater than the first by the same number of pF as the determined self-capacitance of the coil. Now go back to the appropriate inductance scale and take

the reading, which is then correct, regardless of the self-capacitance of the coil. It will be found that errors are negligible when taking direct readings without the self-capacitance correction as long as the self capacitance of the coil is less than 10pF, which is true for most single-layer air-cored coils.

### Measurement of Self-Capacitance of Coils

The principle is to find the resonant frequency of the given coil with a definite added capacitance, then to *double* the frequency exactly, and determine the resulting discrepancy with respect to quartering of added capacitance for maintaining resonance. This is a measure of the self-capacitance of the coil, for we know that doubling the frequency requires *exact* quartering of the total capacitance to maintain resonance (inverse square root law already established in theoretical section). The discrepancy with respect to quartering of the added capacitance must therefore be due to the self-capacitance of the coil.

The self-capacitance scale on the dial of VC1 of the picometer is calibrated on this principle, and subsequent readings are obtained in a straightforward manner. The dial is first of all set to the mark "f" on the self-capacitance scale, near the high-capacitance end of the adjacent  $C_x$  scale. The unknown coil is connected to the "X" terminals and the switch set to disconnect the ferrite aerial, just as for taking an inductance reading. The probe coil of the dipper is applied to the unknown coil, and dip resonance found. The frequency reading on the dipper is noted and the dipper then tuned to exactly double this frequency (changing the probe coil if necessary). VC1 is then turned into the sector with general labelling "2f" near the minimum capacitance end of the adjacent  $C_x$  scale, and fine adjustment made until resonance is restored. The self-capacitance of the coil may then be read-off directly on the scale.

### Calibration of the $C_x$ Scale

The  $C_x$  scale indicates the capacitance *increase* of the tuning capacitor with respect to its zero position (vanes fully open) for any setting, and is used to give direct readings for an unknown capacitance  $C_x$  connected to the "X" terminals, in the manner already described. This is the only scale on the picometer which is calibrated *by measurement*. All

**TABLE 2**  
**Calibration of the Inductance Ranges**

1	2	3	4	5
L value (μH)	Resonant Capacitance (pF) for 1Mc/s (C <sub>res</sub> )	C <sub>x</sub> -scale position (C <sub>res</sub> -27.5pF) C <sub>0</sub>	L-scale "1-2-6"	L-scale "6-30"
60	417	389.5	1.2	6
70	356	328.5	1.4	7
80	312	284.5	1.6	8
90	277	249.5	1.8	9
100	250	222.5	2.0	10
110	227	199.5	2.2	11
120	208	180.5	2.4	12
130	192	164.5	2.6	13
140	178	150.5	2.8	14
150	166	138.5	3.0	15
175	143	115.5	3.5	17.5
200	125	97.5	4.0	20
225	111	83.5	4.5	22.5
250	100	72.5	5.0	25
300	83	55.5	6.0	30

Valid for all units      Varies with individual unit (see text)      Valid for all units

√ F	Range Factor (F) w.r.t. 1Mc/s	Range (0.12-0.6μH)*	Range (√F Mc/s) (22.5Mc/s)*
10	100	0.6-3.0μH	10Mc/s
7.1	50	1.2-6.0μH	7.1Mc/s
3.15	10	6-30μH	3.15Mc/s
2.25	5	12-60μH	2.25Mc/s
1.0	1.0	60-300μH	1Mc/s†
0.710	0.5	120-600μH	710kc/s
0.315	0.1	0.6-3.0mH	315kc/s
0.225	0.05	1.2-6.0mH	225kc/s

\* See text. † Reference range

N.B. Figures slightly rounded off for convenience, within tolerance limits.

other scales are subsequently calibrated by calculation with respect to the C<sub>x</sub> scale, once it is complete on the dial. Tables 1 to 3 show how this is done and Fig. 5 shows a reproduction of the resulting complete scaleplate for the prototype. This may well differ in detail for each particular unit built, according to the zero-capacitance C<sub>0</sub> of the tuning capacitor and circuit strays, as well as the capacitance law of the particular tuning capacitor employed. However, the principles shown in tables 1 to 4 are always valid for calibrating any unit.

The first step in establishing the C<sub>x</sub> scale is to find the point of electrical minimum capacitance of the tuning capacitor. This may well differ slightly from the mechanical stop at the low capacitance end by one or two degrees of rotation, because stray effects can cause a very slight rise of capacitance (1 or 2pF) just before the stop. It is very important to take account thereof, since such a small aberration here, is many times as large as the smallest capacitance reading we desire from the finished instrument, although negligible for normal use of the tuning

capacitor in a radio receiver. Turn the tuning capacitor to the mechanical stop and find the resonance point with the dipper when the ferrite rod aerial is switched into circuit. Now advance the tuning capacitor until resonance at the same frequency reappears. Then set the tuning capacitor half-way between this new setting and the mechanical stop, and find the new resonance point with the dipper. Check whether resonance at the same new frequency re-appears at another slightly different position; if so, move to halfway between the two respective settings. Repeat the procedure until a setting near the low-capacitance mechanical stop is found giving the highest possible resonant frequency which then appears only at this one setting. This is the point of electrical minimum capacitance and should be clearly marked as the zero-point of the C<sub>x</sub> scale.

Now set the tuning capacitor exactly to this zero-point and connect the smallest one of the purchased standard capacitors (about 1pF) to the "X" terminals. Keep the ferrite rod aerial in circuit, in the usual manner for C<sub>x</sub> measurement. Establish resonance with the dipper. Then remove the standard capacitor and advance the tuning capacitor until resonance at the same frequency is restored. Mark the new setting of the tuning capacitor with the known capacitance value of the standard capacitor. Repeat for all available standard capacitors right up to values around 450pF at the maximum capacitance end. The scale will by then be covered with a sufficient number of reference values for drawing-in a complete and continuous scale by interpolation.

As far as standard capacitors are concerned, any commercial type of small capacitor with the closest possible tolerance (preferably +1%) may be used. It does not matter whether mica, ceramic or some form of plastic film types are used. The voltage rating should be about 500V, this preserves maximum accuracy.

**TABLE 3**  
**Calibration of the Coil Self-capacitance Range = LC<sub>0</sub> (See text)**

$\Delta C_{tune} = 400pF$  wanted.  
 $C_x - \text{Reading corresponding thereto} = 400 - C_0 = 400 - 27.5 = 372.5pF$

1	2	3	4
Self-capacitance of coil LC <sub>0</sub>	Total tuning capacitance at ΔC <sub>tune</sub> 400pF (res.= F) C <sub>F</sub>	Required total tuning capacitance at res.= 2F C <sub>2F</sub>	C <sub>x</sub> reading for res.= 2F (C <sub>2F</sub> -LC <sub>0</sub> -C <sub>0</sub> )
zero	400	100	72.5
10	410	102.5	65
20	420	105	57.5
30	430	107.5	50
40	440	110	42.5
50	450	112.5	35
60	460	115	27.5
70	470	117.5	20
80	480	120	12.5
90	490	122.5	5

All readings in pF

**Determination of the Zero-Capacitance of the Tuning Capacitor, C<sub>0</sub>**

The next step of the calibration procedure is to determine the residual capacitance operative across the "X" terminals when the tuning capacitor is set to zero on the C<sub>x</sub> scale. For this purpose, determine the resonant frequency in conjunction with the ferrite rod aerial when the tuning capacitor is set to zero on the C<sub>x</sub> scale (f<sub>zero</sub> scale) and again when set to the highest calibration point (C<sub>x</sub>)<sub>max</sub> (f<sub>full</sub> scale). Table I explains the manner in which C<sub>0</sub> may be calculated from these measurements, using the already familiar inverse square root relationship between capacitance and resonant frequency.

If C<sub>0</sub> turns out to be less than 25pF, add a small trimmer in parallel with the tuning capacitor to increase the value to about 25pF. If the value is, on the other hand, greater than 30pF, rearrange the wiring or unscrew a trimmer which is most likely already attached to the tuning capacitor and screwed-in too far. Seal any trimmer securely after appropriate adjustment before proceeding with further calibration. The purpose of adjusting C<sub>0</sub> to be between 25 and 30pF is to make sure that it is dominantly due to VCI and swamps the self-capacitance of the ferrite rod aerial. Only then is C<sub>0</sub> essentially the same on both C<sub>x</sub> and L<sub>x</sub> measurements (ferrite rod aerial in circuit or out of circuit). On the other hand, the value is still small enough to give clear shifts of dip at fractional-pF readings.

**Calibration of the Inductance Ranges, L<sub>x</sub>**

In principle, any range frequency to which the dipper is tuned will lead to a corresponding L<sub>x</sub> range with the available range of C<sub>x</sub> + C<sub>0</sub> values as calibrated tuning capacitance. Any shift of the range frequency will lead to a corresponding shift of inductance range limit values. In practice, it is convenient to select a reference range with 1Mc/s as range frequency and establish a numerical scale calibration with respect thereto. Further range frequencies are then calculated according to the already familiar inverse square-root law relating inductance and resonant frequency, such that the respective inductance ranges involve decimal multiples and sub-multiples of the numerical calibrations already established on the reference range.

To avoid excessive errors due to the self-capacitance of single-layer air-cored coils, the tuning capacitance must be maintained large with respect thereto (at least 50pF) over the entire L<sub>x</sub> range. The calibration thus cannot be sensibly taken right up to the C<sub>x</sub>=zero end of the tuning capacitor dial. It must stop earlier. Consequently it is not possible to cover a swing of 10:1, but only 5:1, on any single range. The decimal scale factor ranges must therefore be interpolated with binary scale factor ranges. In other words, two sets of numerical calibrations differing by a factor of 5 are marked against the same L<sub>x</sub> scale-arc, and each is used in conjunction with decimal scale factors established by suitable choice of range frequencies. The complete set of selected range frequencies and appropriate L<sub>x</sub> scale limits for each one are then marked on the dial, wherefrom it is immediately obvious for all subsequent uses, which numerical calibration is appropriate to each range frequency. Table 2 gives concise details of the procedure.

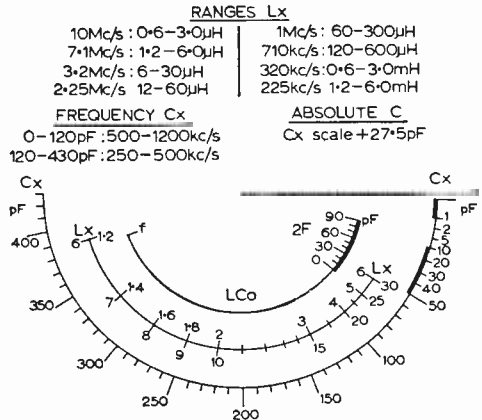

Fig. 5—Scaleplate of the prototype according to tables 1-3.

The highest and lowest inductance values giving resonance at 1Mc/s with the available minimum and maximum values of (C<sub>x</sub> + C<sub>0</sub>) on the tuning capacitor are first of all calculated from the resonance formula (1) in the theoretical section above. The total capacitance required for resonance at 1Mc/s is then calculated at convenient inductance intervals within this range, as shown in columns 1 and 2 of Table 2. The value for C<sub>0</sub> (27.5pF in the prototype) is then subtracted from each total capacitance value, to give the C<sub>x</sub> scale reading for the dial radius line on which the corresponding L<sub>x</sub> scale numerical markings (columns 3, 4, 5 of Table 2) are to be entered on their scale arc. The L<sub>x</sub> scale can be completed in this manner by pure calculation and reference to the C<sub>x</sub> scale.

Finally, the appropriate range frequencies are chosen as shown on the bottom half of Table 2, and these are entered on the dial above the scale arcs, together with the corresponding inductance ranges covered thereby.

**Calibration of the Coil Self-Capacitance Scale LC<sub>0</sub>**

The initial resonant frequency is always established at a total additional tuning capacitance (i.e. additional to the self-capacitance of the coil) of 400pF. The total tuning capacitance is thus in any given case equal to (400 + LC<sub>0</sub>) pF, where LC<sub>0</sub> is the self-capacitance of the coil which is to be determined.

When the frequency is now doubled, the new total tuning capacitance required for resonance is exactly one quarter of the previous value, i.e. 100pF + LC<sub>0</sub>/4pF. Of this, an amount LC<sub>0</sub> is still present due to the coil itself, and C<sub>0</sub> is provided by the tuning capacitor zero capacitance and circuit strays. The remainder

$$100 + LC_0/4 - LC_0 - C_0 \text{ pF} \\ = 100 - 3 LC_0/4 - C_0 \text{ pF}$$

must be supplied by a corresponding setting of the tuning capacitor with respect to the C<sub>x</sub> scale. We can thus substitute various values for LC<sub>0</sub> into this expression, and enter the chosen LC<sub>0</sub> values against the corresponding positions on the LC<sub>0</sub> scale arc on

TO SHOW THE LOW-VALUE ACCURACY OF THE PICOMETER

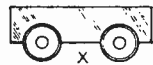

Terminals shorted with stout brass bar  
 L-range frequency = 22.5 Mc/s  
 L-range = 0.12 - 0.6 μH  
 Reading = 0.28 μH  
 The inductance of the internal wiring between X-terminals and tuning capacitor is thus 0.28 μH

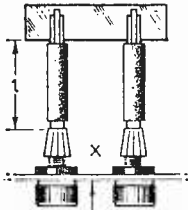

Terminals shorted with same stout brass bar, but pair of insulated plug-in alligator clips interposed  
 L-range frequency = 22.5 Mc/s  
 L-range = 0.12 - 0.6 μH  
 Reading = 0.34 μH  
 Thus inductance of the pair of alligator clips = 0.34 - 0.28 μH = 0.06 μH

(b) Panel

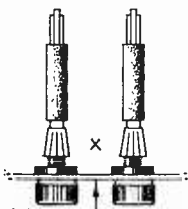

Capacitance measurement with pair of insulated alligator clips  
 Reading for distributed capacitance obtained = 0.6 pF  
 (Note that this measurement is made at medium wave frequencies, i.e. around 1 Mc/s)

(c) Panel

Check:

(A) Transit time for line section with distributed total inductance L and distributed total capacitance C

$$= \sqrt{L(\text{Henry}) C(\text{Farad}) \text{ seconds}}$$

$$= \sqrt{(6 \times 10^{-8})(6 \times 10^{-13})} = 1.9 \times 10^{-10} \text{ seconds}$$

For normal λ/4-line resonance, transit-time = 1/4 period.

Thus λ/4 resonant frequency

$$= \frac{1}{4T} = \frac{1}{4 \times 1.9} \times 10^{10} \text{ c/s}$$

$$= 1316 \text{ Mc/s}$$

(B) From pure geometry:

Effective length "l" in (2) above = 5 1/2 cm. = λ/4 for resonance

Thus λ = 22 cm for resonance, giving resonant frequency: 1364 Mc/s

THE ORDER OF AGREEMENT IS THUS EXCELLENT PROVING THE RELIABILITY OF THE LC-PICOMETER DOWN TO SUCH LOW VALUES AS 0.06 μH/0.6 pF (L, C values of a pair of alligator clips).

the same dial radii as the respective C<sub>x</sub> values for the doubled-frequency resonance points. Table 3 depicts this procedure, showing how the LC<sub>0</sub> scale is quickly established by calculation with respect to the C<sub>x</sub> scale.

The reference point on the LC<sub>0</sub> scale arc, at which resonance at the initial frequency is established in the first place, must be marked in at the point of 400 pF total additional capacitance, i.e. (400 - C<sub>0</sub>) pF with respect to the C<sub>x</sub> scale.

**Required Tuning Capacitance**

This has completed the calibration procedure of the entire dial for the picometer. The established value for C<sub>0</sub> should also be entered on the dial. It may then be added mentally to the C<sub>x</sub> scale reading for any setting, to obtain the total capacitance appearing at the "X" terminals for that setting. This information is required when desiring to determine the tuning capacitance for a predetermined resonant frequency with a given unknown coil. For this purpose, connect the coil to the "X" terminals, apply the dipper to the coil and adjusting it to the required resonant frequency. Adjust VC1 until resonance is established and then add C<sub>0</sub> to the C<sub>x</sub> reading. The result is the required tuning capacitance which must be added externally to the coil. If the coil is to be soldered into some position in a piece of equipment, first determine the circuit stray capacitance at that position, and reduce the actual capacitor subsequently soldered across the coil by that amount.

**Measuring Circuit Stray Capacitance**

The procedure is identical to that used and already described for measuring a lumped capacitor. Whilst the latter may be connected directly to the "X" terminals of the picometer with short leads of negligible additional capacitance error, this is not the

case when measuring the stray capacitance between two points in a piece of equipment, since relatively long leads must be taken from the "X" terminals of the picometer to the respective test points. The stray capacitance of these leads is eliminated without calculation in the following simple manner. Connect the leads to the "X" terminals and to the test points, set VC1 to zero-scale and establish resonance. Then disconnect both leads at the test points in the equipment, but leave the ends close thereto and the other ends still connected to the "X" terminals. Also do not disturb the geometric disposition of the connecting leads, which may otherwise be chosen arbitrarily at the outset. Now advance VC1 to re-establish resonance. The C<sub>x</sub> reading is then correct for the stray capacitance between the test points alone, since the connecting lead capacitance is still connected to the picometer and has thus not been replaced on the C<sub>x</sub> scale. This procedure will give very accurate readings for circuit stray capacitances.

Certain subsidiary factors must be observed, however. If there is a d.c. resistive path connected directly between the two test points between which the stray capacitance is required, or if such a resistive path in series with a large capacitance is present between these points, then it must be interrupted for the measurement if its resistance represents intolerable damping on the tuned circuit. For example, if it is desired to determine the stray capacitance between the anode of an amplifier stage and chassis, the anode load resistor must be disconnected at the cold (h.t.) end. Otherwise it is in parallel with the test points via the h.t. smoothing or decoupling electrolytic and would impose such heavy damping that a dip reading would be intolerably broadened or absent. There is generally negligible change of the

—continued on page 376

THE steady progress made by transistors in ousting valves has for some time been halted, as far as the world of television is concerned, by the impossibility of replacing the camera tube and the picture cathode ray tube by solid state equivalents. One new development and steady progress in another better known field of research have now turned this impossibility into nothing more than a mild improbability. The Westinghouse Corporation of U.S.A., working on a contract for the National Aeronautics and Space Administration (N.A.S.A.) has produced a completely solid state camera, admittedly crude as far as the present techniques go, but capable of considerable development. Other workers have produced matrixed electroluminescent panels which could form the basis of a replacement for the cathode ray tube. The immediate application of these devices will be in research work, possibly later for various forms of facsimile transmission, as they offer the opportunity for reducing considerably the bandwidth normally occupied by a TV picture.

### Scanning

To understand the operation of this new system, we must go back to the very earliest ideas for television, even before the idea of scanning was established. In these days, it was seen that a picture could be transmitted only if it could be broken down into small pieces and information transmitted at intervals about the brightness of each piece. The way in which we do this now, of course, is to scan the picture horizontally and vertically. The size of each piece of information which we send is determined by the bandwidth which we can use. Thus the height of each piece is set by the distance between lines, hence by the field scanning rate; and the width of each piece is set by the highest

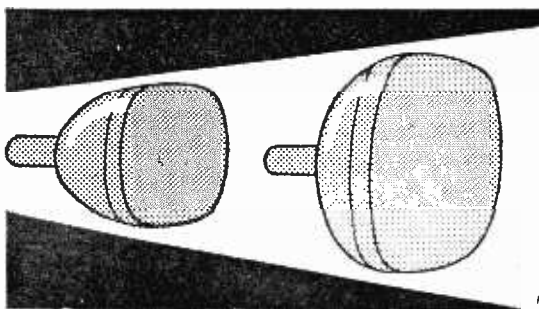

frequency which the video amplifiers of our equipment will pass. We may note here that our pictures have "pieces" which are wider than they are high, which means that there is some resolution to spare in the vertical direction. This is why the loss of vertical resolution in the SECAM colour system is tolerable.

There is no law, of course, which says that we must break down our pictures in this way. We would equally well break them up into square areas and sample the brightness of each at random, then, providing the receiver were kept in step with the transmitter, an equally good picture would be received. What is more interesting is the fact that a picture transmitted in such a way occupies far less bandwidth than a scanned picture. Furthermore, when the picture is formed of random elements, the rate at which elements need to be repeated is very low, providing a long persistence device is used at the receiving end; bandwidths of 70kc/s become possible.

Unfortunately, completely random sampling of picture elements is not readily achieved, and would defeat its own purpose, as synchronisation becomes very difficult. It has been calculated that the bandwidth required for synchronising purposes would greatly exceed that formerly required for the whole picture, so true random dot picture formation is out as a feasible means of TV transmission. However, it turns out that a true random dot pattern is not necessary, and a pattern which repeats at long intervals can provide similar results without requiring too much in the way of synchronising (Fig. 2).

So far, the experiments in "pseudo-random dot" techniques (which would require an article in themselves to describe) have been carried out using conventional cameras and c.r.t.'s. Let us see how well they would fit into the camera system developed by Westinghouse, and the electroluminescent panel receiver. The Westinghouse pick-up device is very similar in principle to the newspaper facsimile machines of long ago. In these machines, a photographic transparency was placed over a surface of selenium which was ruled off into squares. As light was shone on to the photograph, voltages were developed on the selenium squares which were illuminated. A switch now sampled the voltage of each square, the voltages were transmitted by telegraph, and the picture was reconstituted at the receiving end by an inking arm moving synchronously with the transmitting switch and inking a dot whenever the voltage rose above a certain level.

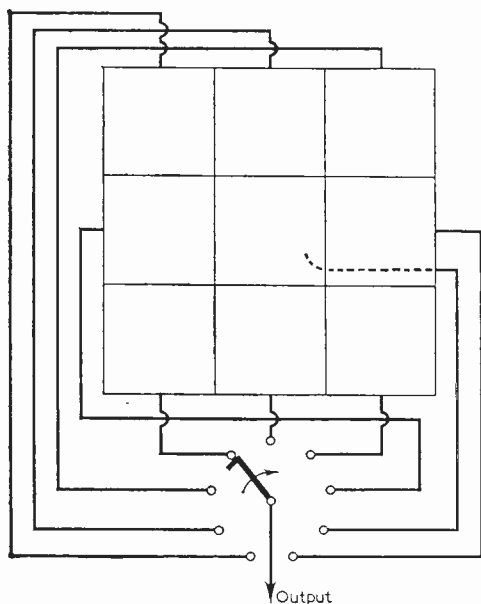
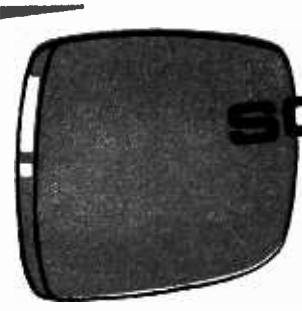

Fig. 1—Sequence switching of a panel.





# SOLID STATE TELEVISION

by K.T. WILSON

## Use of Microelectronics

The Westinghouse device consists of a panel,  $\frac{1}{2}$  in. square, of phototransistors. There are 50 phototransistors along each side of the panel, making a grand total of 2,500 phototransistors in the whole device. The number involved is the reason why such a device, although simple in principle and giving only the equivalent of 50 line pictures, has not been brought to this stage before. Only by using the techniques of microelectronics could so many phototransistors be assembled in the space. At present, the techniques of photoetching used in making micro-circuits, permit lines of 0.0004 in. to be made. If phototransistors of only 0.0006 in.

sides could be reliably made, the half inch panel would have 500 phototransistors per side, 250,000 in all, corresponding to 500 line pictures. Alternatively, a larger panel could be used. At the present rate of packing, a panel of 5 in. square would be required for 500 line TV.

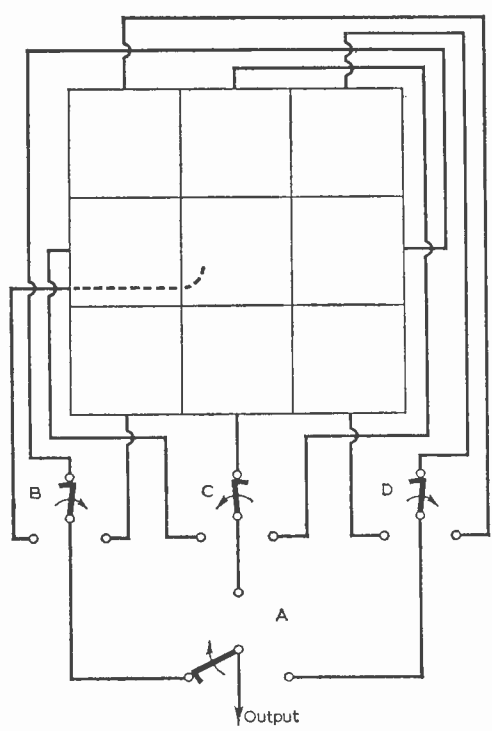

Fig. 2—Pseudo-random scanning of a panel.

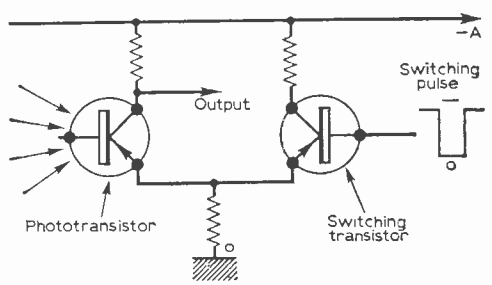

Fig. 3—Switching of a phototransistor.

The difficulty of such a system is not the fabrication of the phototransistors, however, difficult as that is. Some form of scanning or other sampling must be used in order to make the device workable as a camera. Since there is no electron beam to scan the phototransistors, the output of each must be connected to the video amplifier in turn by means of some sort of switch (Fig. 3). This part of the operation is familiar to designers of computers, who are faced with the problem of designing a memory unit, any part of which can be read at random by giving appropriate instructions.

In fact, similar techniques are used. A bank of switching transistors is attached to the array of phototransistors, all the outputs being connected to the video amplifier. The switching transistors are then operated by further switching stages via a matrix which guides the switching pulses to the appropriate transistors. The whole circuit resembles a counter in the scale of two, and the application of one pulse to the input results in one phototransistor being switched. The next pulse selects the next phototransistor and so on. The interesting thing about system is that the "scanning" need not be in lines, but may be "pseudo-random" as described earlier, according to the way in which the switching matrix is connected. Since the switching mechanism is made by microelectronic techniques, any scheme of switching can be built into the device.

This structure forms the camera end of a completely solid-state TV system. For the receiver end, the techniques used are almost identical, but the panel must consist of small square pieces whose brightness is proportional to the voltage across them. Electroluminescent cells form the basis for such a panel.

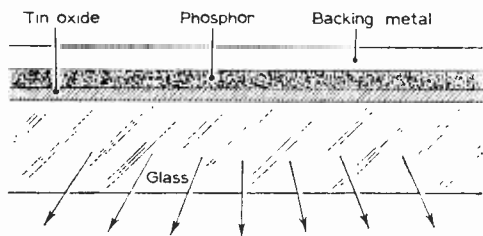

Fig. 4—Electroluminescent panel (magnified).

### Electroluminescent Cells

An electroluminescent phosphor is a material which emits visible light when an a.c. voltage is placed across the thickness of the material. A typical electroluminescent cell (Fig. 4) is rather like a flat capacitor in construction, except that one of the conducting plates is transparent and the dielectric is the electroluminescent material. Such a cell is made on a glass slide by first coating the glass with a conducting transparent layer of tin oxide, then spraying on the phosphor which is suspended in the same sort of nitrocellulose binder as is used for making up spraying paint. Finally, the back of the phosphor layer is coated with aluminium or copper to form the other contact of the cell. The brightness of such a cell increases greatly as the voltage across it is raised, and as the frequency of the exciting voltage is raised.

Unfortunately, when a set of electroluminescent areas is switched in sequence as is required for TV

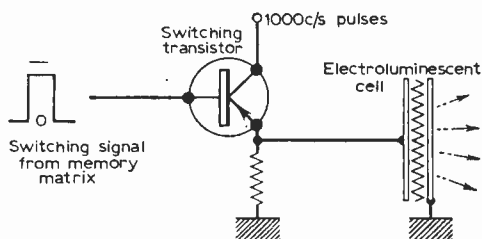

Fig. 5—Switching electroluminescent cell.

use, the average brightness is very low, as the persistence of the electroluminescence is very short. The answer to this problem is to get away from the method of scanning completely, and use a system which permits each element to be lit continuously as long as it represents a piece of the screen which is intended to be bright. To operate in this way, each piece of the electroluminescent panel must be operated by a switch (Fig. 5) which is controlled by a memory device. The video signal which is transmitted is only the difference between one picture and the next, for practically all TV pictures this difference is very small, so the amount of information which needs to be sent over a period of time using this method of transmission is very small. This means that a considerable decrease in bandwidth has been achieved, and the system used ties up excellently with the pseudo-random scan technique which we discussed at the beginning of the article. So here we have many contributions from widely different sources of engineering technology blending together, and the result is a totally revolutionary type of TV system. We shall not see this system in use for entertainment purposes for many years to come; perhaps never, for the investment in the present system has reached the stage where massive change is nearly impossible. We shall, however, undoubtedly see it in the form of a "Picturephone" device, and perhaps in many other applications of TV where there is no reason to be tied to the presently used scanning systems. ■

## PRACTICAL ELECTRONICS

4 special projects for the motorist:

LDR Parking Light

Direction Indicator

Anti-theft Alarm

Tachometer

FREE BOOKLET  
TRANSISTOR DATA

PLUS

Simple Transistor Tester

May issue on sale NOW

## PRACTICAL TELEVISION BINDERS

The Practical Television Easi-binder is designed to hold normally 12 issues. Please state volume number required otherwise a blank cover will be sent. The price is 11s. 6d. inclusive of postage.

Order your binder from:

Binding Department, George  
Newnes Ltd., Tower House  
Southampton Street, London  
W.C.2

---

# TV SERVICING

## *An Honourable Profession*

by *E. A. W. Spreadbury, M.I.E.R.E.*

(Chairman of the Society of Electronic and Radio Technicians)

---

**S**ERVICE engineers, to call them by a name by which they are very widely identified, are a very mixed category of individuals with a rather unsatisfactory public "image". The man in the street, to use another widely accepted metaphor, often regards the man who repairs his radio receiver, and even more so if it is his television receiver, with distrust and suspicion.

The distrust relates not to the service man's honesty, but to his ability; and the suspicion to the fear that he will charge more than the job is worth because of the man's possible incompetence.

This view illustrates the worst aspect of the public image of the service technician, but there is no doubt that it is one that has acquired very wide acceptance. We all meet the customer now and again who sings the praises of his radio dealer's wonderful service department, but bad news travels faster than good, and the worst aspect excites interest more readily than the best, and it receives much more publicity.

The vast majority of radio and television service technicians are highly skilled at the art and as keen as radio amateurs on the technical aspect of their work. They love it, and when they get together at meetings there is nothing they like better than the equivalent of a "ragchew" of the kind so greatly enjoyed by radio amateurs.

The deprecatory element of the publicised image results from the incursions into service work of certain individuals who "dabble" at the work. They have a smattering of technical knowledge and a natural inclination to experiment, and after one or two successes at repair work they see easy money in servicing.

There is a shortage of properly trained technicians, and some dealers, who may be in desperate straits and are not themselves sufficiently knowledgeable to tell the difference, take on these dabblers in the belief that they are skilled technicians. Once in a regular servicing job their weaknesses become very evident and the reputation of the innocent suffers with that of the guilty.

It was to enable properly skilled men to be distinguished from the unskilled that the Radio Trades Examination Board began to organise servicing examinations 21 years ago, and the RTEB Final Servicing Certificate is now the recognised national qualification for radio, television and electronic service work, and 25,000 candidates have submitted themselves for their examinations.

It had been felt for some time that some recognition of these men as a class should be established, something which would establish their professional status as technicians, very much in the same way as the status of engineers is established by association with their respective engineering institutions.

This need led in 1964 to the birth of the Society of Electronic and Radio Technicians, a society formed on the same lines as the engineering institutions but at the technician level. Its first qualification for membership was one of the Final Certificates of the RTEB (radio or electronics) but this was broadened to embrace quite a number of other qualifications of equal practical and academic achievement.

SERT was inaugurated in June, 1964. There are three membership grades: full member, associate, and student, and possession of the RTEB Final Certificate is one of the qualifications for associate-ship, provided that the applicant is 21 years old and has had three years' experience in radio or electronic service work.

To become a full member he must be at least 30 years of age and have had not less than ten years' experience, five of them in a position of responsibility. Other qualifications include HNC, City and Guilds Telecommunications, or Electrical Technicians (with electronics), certain PMG certificates and a number of qualifications in the Armed Forces.

Admission to any grade is very strictly scrutinized by the Membership Committee, who are determined to maintain a high standard of technical skill and ability. Students are admitted on possession of certificates of lower or preliminary grades, or if they are attending full-time specified courses. Annual subscriptions for membership in the UK are: members £5; associates £4; students £1 or £1 10s. according to age. Sir Ian Orr-Ewing, Bt., OBE, MA, MIEE, MP agreed to become the first President of SERT.

Advantages of membership include regular technical meetings at which members can discuss common problems and hear lectures by engineers. These take place at ten centres throughout the UK. Members also receive the SERT Journal. They also have their own professional body, which gives them standing, and they have a ready platform from which they can present their own ideas by delivering lectures to their fellows.

By this means the service technician today has achieved recognised professional status that is denied to the less skilled man. He now has professional standing by which he can be distinguished. An employer can confidently employ a technician who is entitled to add MSERT or AMSERT after his name, and his customers can gain confidence from the display of the technician's certificate in his dealer's shop. In the same way the dealer can ensure the engagement of a serious, keen and conscientious apprentice or bench worker if he can claim to be a Student SERT.

SERT was founded by the RTEB, and the two bodies share the same offices which are managed by their joint Secretary, A. J. Kenward, B.Sc., AMIERE. Originally they were provided with office accommodation at the IERE headquarters at 9 Bedford Square, W.C.1, but since January, 1965, they have had their own office at 33 Bedford Street, Strand, London, W.C.2, whence further information is available on request. ■

# TV TERMS AND DEFINITIONS EXPLAINED

Gordon J. King

## Part II Automatic Gain Controls (AGC)



**T**HIS system is not particularly new. It was (and still is) employed in early sound-only receivers but its development over the years has spread to the sound and vision channels of television sets and its name has changed from the original "automatic volume control".

It is simply a system which provides a control of gain of the radio-frequency (r.f.) and intermediate-frequency (i.f.) amplifiers of the receiver. The volume control of a radio (or audio amplifier) differs in function in that it provides an adjustment of the signal level applied to the audio section and does not work in terms of controlling the gain of a stage. The old name was thus something of a misnomer—hence the change from a.v.c. to a.g.c.

The term implies that the gain is controlled automatically. This is, in fact, achieved by the circuit being fed with a portion of the i.f. signal, a small diode then being used to rectify the signal and produce a d.c. bias. This bias is arranged to be negative-going. That is, it becomes more negative the greater the strength of the i.f. signal delivered by the set. This is the "control bias" that is applied through filters to the control grids of the r.f. amplifier (if used), sometimes the frequency changer and the i.f. valves.

The effective amplification given by these controlled valves is governed by their grid bias. The greater the negative bias, the smaller the amplification or resulting stage gain. In this way, therefore, the gain of the stages is controlled automatically. The stronger the signal, the greater the negative control bias and the smaller the stage gain; and the weaker the signal, the less the bias and the greater the stage gain.

This system is made possible because an amplitude-modulated (a.m.) sound radio signal varies about a mean signal level. However, with television there is no mean level because with positive modulation the modulation level rises with brightness of the scene being transmitted from black level (30 per cent. modulation) to peak white (100 per cent modulation). Nevertheless, due to the fact that the average modulation level during the course of a programme remains reasonably constant, a simple form of a.g.c., similar to that used in sound-only sets, is used in the majority of television receivers. This is called *mean-level a.g.c.* The system can be exploited better on the negative-going modulation of the 625-line standard.

The control bias is picked up from the control grid of the sync separator valve. The potential at this electrode is negative because the sync pulses drive the valve into grid current and cause a capacitor to

charge. The grid is thus negative, and the magnitude of this voltage is influenced by the strength of the video signal reaching the sync separator from the video amplifier valve. The stronger the video signal, the greater the negative voltage fed back from the sync separator control grid to the r.f. and i.f. amplifier valves.

The system then works in the way already explained. Its chief attribute is in holding constant the video signal applied to the picture tube over the various channels, thereby avoiding the need for contrast control readjustment on changing from channel to channel.

The basic elements of a mean-level vision a.g.c. system are shown in Fig. 6. Here the contrast control simply sets the gain of the controlled stages to the required initial level by applying a countering positive voltage to the negative a.g.c. line, the automatic negative controlling bias then taking over.

In spite of this simple system being used in the majority of domestic models, it has a number of shortcomings. An important one is that it tends to

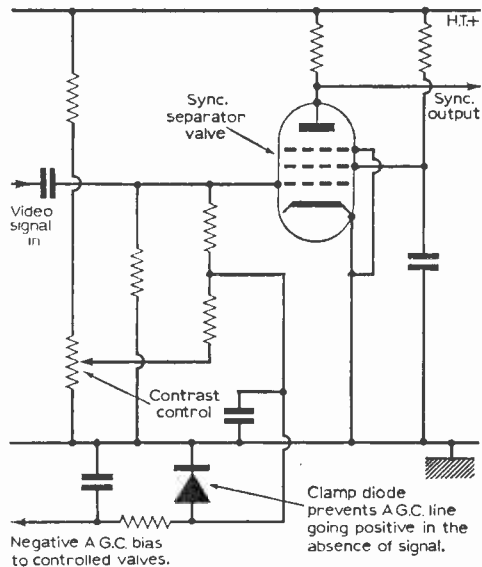

Fig. 6—Elements of mean-level a.g.c. system.

eliminate the black-level reference of the video signal. An effect of this is that the gain of the receiver alters under the influence of how much black and white is present in the televised scene, rather than it altering only in a corrective manner according to the actual *strength* of the received signal.

This does curious things to the picture. For example, a dark scene tends to develop a dirty grey appearance since the gain of the stages is increased by the picture going dark. Moreover, if the majority of the scene is in the shade with a small strip of white sky showing, the shade often disappears into complete blackness, leaving only the bright sky! On most pictures, though, mean-level a.g.c. is perfectly satisfactory.

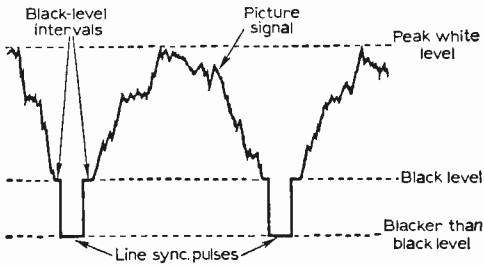

Fig. 7—Black-level intervals of a signal.

A system called "black-level a.g.c." reduces such shortcomings, since for a control bias reference it uses the black-level intervals of the signal, as shown in Fig. 7. These intervals are at true black-level irrespective of the picture signal amplitude.

Various tricks of electronics are employed for sampling these black-level intervals, but the majority of them use some sort of "gating" arrangement, whereby the a.g.c. system is "opened" only at the times that the signal falls to the selected black-level intervals. At all other times the a.g.c. system is closed and is thus unaffected by the picture signal proper.

It should be noted, however, that even with true black-level vision a.g.c. the reproduced picture black-level may still be impaired owing to other design factors of the set, such as poor e.h.t. regulation, the loss of d.c. coupling in the video amplifier and picture tube circuits and so forth. For this reason, most manufacturers continue to adopt the mean-level system which is less costly than the gated systems. There are various circuits which synthetically serve to re-apply the lost black-level.

**Band I**

This carries five v.h.f. channels on the 405-line standard as below:

Channel No.	Sound Freq. Mc/s	Vision Freq. Mc/s
1	41.50	45.00
2	48.25	51.75
3	53.25	56.75
4	58.25	61.75
5	63.25	66.75

Thus, each Band I channel is 5Mc/s wide and the sound carrier is below the vision carrier by 3.5Mc/s.

**Band III**

This carries eight v.h.f. channels on the 405-line standard as below:

Channel No.	Sound Freq. Mc/s	Vision Freq. Mc/s
6	176.15	179.75
7	181.25	184.75
8	186.25	189.75
9	191.25	194.75
10	196.25	199.75
11	201.25	204.75
12	206.25	209.75
13	211.25	214.75

Each channel in this band is also 5Mc/s wide with the sound carrier 3.5Mc/s below the vision carrier

**Band IV**

This carries fourteen u.h.f. channels on the 625-line standard as below:

Ch. No.	Vision Carrier Mc/s	Ch. No.	Vision Carrier Mc/s
21	471.25	28	527.25
22	479.25	29	535.25
23	487.25	30	543.25
24	495.25	31	551.25
25	503.25	32	559.25
26	511.25	33	567.25
27	519.25	34	575.25

**Band V**

This carries thirty u.h.f. channels on the 625-line standard as below:

Ch. No.	Vision Carrier Mc/s	Ch. No.	Vision Carrier Mc/s
39	615.25	54	735.25
40	623.25	55	743.25
41	631.25	56	751.25
42	639.25	57	759.25
43	647.25	58	767.25
44	655.25	59	775.25
45	663.25	60	783.25
46	671.25	61	791.25
47	679.25	62	799.25
48	687.25	63	807.25
49	695.25	64	815.25
50	703.25	65	823.25
51	711.25	66	831.25
52	719.25	67	839.25
53	727.25	68	847.25

Each channel in Bands IV and V is 8Mc/s wide with the sound carrier 6Mc/s above the vision carrier. The sound carrier frequency is rarely referred to in the u.h.f. bands, as the 6Mc/s interval between sound and vision represents the "intercarrier frequency". Channels 35 to 38 inclusive between Bands IV and V are not allotted, neither are Channels 69 to 81 which complete Band V.

### Bandwidth

This describes the frequency limits of a tuned circuit, amplifier or filter. The bandwidth is generally given between those frequencies where the response falls to 3dB (half power), as shown in Fig. 8

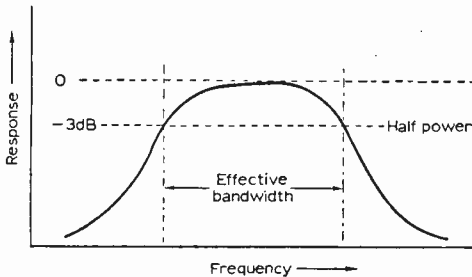

Fig. 8—Response curve depicting effective bandwidths.

### Beam Current

The electron current of the beam emitted from the electron gun of the picture tube. This cannot easily be measured by connecting a current meter in series with the tube final anode owing to the presence of c.h.t. voltage. However, an idea of its value can be gleaned by connecting the current meter in series with the tube cathode. Beam current is usually in terms of microamperes ( $\mu\text{A}$ ).

### Black-after-White

This is a picture fault symptom in which dark objects are outlined on the right-hand side by a white line and white objects outlined by a black line. It is caused by damped oscillation ("ringing") in the vision circuits, and can arise due to misalignment of the vision i.f. channel and a fault in the video amplifier. To some degree the effect is desirable in that it tends to improve the apparent sharpness of a picture.

### Black-Level

For the best picture reproduction the black-level should remain fixed after setting it relative to the picture tube with the brightness control. The correct setting is established by removing the aerial, turning the brightness control up until screen illumination (raster) is present and then turning the control back again until the raster is only just visible. Re-connecting the aerial and turning up the contrast control should theoretically result in a picture of correct black-level.

Unfortunately, modern domestic sets feature no black-level clamping device, resulting in the black-level altering with changes in picture brightness (see under a.g.c.). It is thus necessary to set the brightness control a little in advance of the ideally correct setting to avoid the picture from being excessively black and white when there is a smallish area of peak white and a lot of dark or black in the scene.

Some very early sets and most studio-quality monitor sets feature a circuit that locks or clamps the signal black-level to the tube bias.

### Blocking Oscillator

This is a type of oscillator that is often used to produce the line and field timebase drive signals. It is basically a feedback oscillator that is prevented from building up into a complete sine wave signal by the charging of a capacitor which "blocks" the oscillation. A part cycle of oscillation occurs each time the charging capacitor is discharged through a resistor.

The charge or discharge of the capacitor often forms the drive signal, the oscillator action simply charging or discharging the capacitor across which the drive signal is developed.

### Booster Amplifier

This is a recent term that refers generally to a small transistor amplifier that is connected between the aerial and the aerial socket of the set to boost the signal in areas of weak signal field or where it is required to use the simplest possible aerial system.

The attributes of such devices are that they are self-contained with an internal battery, transistorised and of very low noise generation, thereby amplifying weak television signals without adding to the background grain, which was a disadvantage of earlier valve-type counterparts.

### Booster Diode

This is the high peak voltage diode, such as the PY81, used in the line output stages of television sets. Its purpose is to reclaim energy from the "overshoot" of line signal in the inductive elements of the line output stage and then utilise this energy for almost the first half of the line scan, the line output valve then taking over to provide energy for the remaining period of the scan.

Efficiency is thus gained, and for this reason the diode is sometimes termed "efficiency diode". The diode also directs oscillatory energy into a "charging capacitor" (sometimes called the "boost capacitor") and the potential developed across that capacitor (in the region of 500 volts) is used to supply the field timebase oscillator, the first anode of the picture tube and the focus electrode.

### Brightness Control

This serves simply to adjust the bias on the grid of the picture tube, thereby increasing or decreasing the density of the electron beam and turning up or down the picture brightness. It is also used to establish the correct picture black-level (see under Black-Level).

### Cathode Rays

This term was originally applied to the beam of electrons emitted from a heated cathode and attracted to a nearby positive anode in a vacuum tube.

### Cathode-Ray Tube (CRT)

In television parlance, the term used is "picture tube" (see under Picture Tube).

—continued on page 368



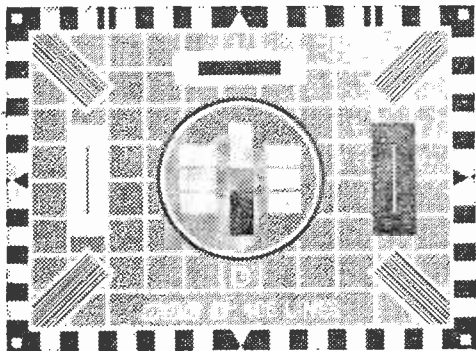

# TRIMMING by ★ TEST CARD ★

By G. R. Wilding

**V**ISION or sound symptoms of receiver misalignment allied to evidence of damaged cores and unsealed trimmers invariably indicates previous unsuccessful attempts to rectify a particular tuning defect.

It may have been sound on vision, vision on sound, low gain or poor definition on one or both channels, but more than likely as receiver response is brought back to normal, the defect will become obvious.

All too often in practice, some repairers endeavour to rectify certain faults, such as lack of gain, by trimmer manipulation when really a faulty component is the cause.

For instance, if a receiver has inferior resolution of the higher Test Card gratings and yet requires full contrast setting, it is more than likely that a correct staggering of the tuned circuits to improve definition will result in an unacceptable sensitivity level.

It then becomes necessary, of course, to rectify the cause of the low gain before a complete re-servicing to makers' standards is possible.

Similarly, you may find on adjusting a particular transformer core that as you approach the optimum setting, mild self oscillation develops or heavy patterning, necessitating a return to the original incorrect point.

## Instability

Here again, the cause of the instability, probably the valve associated with the stage or an o/c decoupling capacitor, must be replaced before optimum re-alignment can take place.

Then lack of volume caused by mis-tuning of the sound i.f.'s to eliminate vision-on-sound buzz will necessitate some service work if the sound i.f. strip is to be correctly peaked.

Most of the seeming alignment defects caused by component failures were covered in last month's issue, and must be borne in mind when endeavouring to line-up a set to original standards.

Then as stated in that article, certain basic rules must be strictly adhered to when trimming a receiver purely by Test Card observation.

Briefly, they are as follows:

1 All coil and i.f.t. trimmers must be identified, preferably by reference to a service diagram pictorial layout.

2 All tuner and i.f. valves must be fully up to standard, or the loss of gain experienced when widening the response curve where necessary may give the erroneous impression that adjustment has been carried too far.

3 Tuner contacts and valve pins must be cleaned to avoid contrast level changes.

4 A really good aerial is essential. Set-top and room aerials, although very effective in many areas, may well have poor Band I/III balance, incorrect sound/vision balance or restricted bandwidth, and make a difficult job even more so.

5 Trimmer blade width must not exceed core slot width, or there is great danger of damaging the head so that it cannot even be subsequently moved.

6 The chassis should be withdrawn as it is extremely difficult otherwise to adjust every trimmer while closely watching resolution and gain.

7 When both Test Cards are withdrawn,—stop. Trimming by Test Card is purely a matter of constantly resolving the highest frequency with the greatest gain compatible with good sound/vision balance and freedom from undue ringing, V on S or S on V, with a careful painstaking approach. Haste is fatal to good work.

Where a fine tuner is incorporated, rock with every trimmer adjustment to define the best tuning point, and constantly change channels to ensure that good Band I/III balance is being maintained. It is quite easy to finish up with superb resolution on one channel and very inferior results on the other.

In fact, very often the final alignment will be a slight compromise between the two frequencies.

Unless it is certain that tuner trimmers have been adjusted, and they rarely are, due to their relative inaccessibility, leave them severely alone with the sole exception of the i.f. output trimmer.

This is usually mounted on top of the tuner, close to the frequency-changer valve and the co-ax output lead. It is often quite sharply tuned and needs constant re-adjustment when rectifying poor sound/vision balance, poor Band I/III balance, S on V or V on S especially when re-aligning the early stages.

## Core Settings

Repeatedly go over each core setting when any major improvement is effected by adjusting any one, since the remainder will probably no longer be at their best setting.

All adjustments are closely integrated, and even tuning the sound take-off circuit will markedly affect the video response.

If curing any vision alignment defect tends to reduce sound, don't assume the tuning change to be incorrect. The sound i.f. strip may also be

**TRIMMING BY TEST CARD — continued from page 366**

somewhat out of alignment and need to be changed to accommodate the improvement in the common i.f. response.

Thus it may well be that each core or trimmer will be re-set a score or more times before an acceptable overall response is obtained.

This process of trimming is usually a gradual one, slowly narrowing the discrepancy between actual and specified performance but unfortunately with more than one retrograde step.

Hence the need for careful deliberate action, especially when adjustment is approaching finality, for it is painfully easy to lose an hour or more constant improvement by one wrong action and trying to put it right by re-adjusting the wrong coil.

When close to optimum it is often advisable to finalise at a later occasion, when completely fresh and to take the trouble of marking the core slot position on the transformer can or chassis, so that if that extra bit of resolution or gain cannot be resolved, it is an easy matter to return to the original settings.

**Adjustment Difficulties**

If any transformer cores tune the slightest degree above the surface of the can, it is highly probable that the general i.f. frequency is set too high, while if tuning of the sound rejector has to be spot-on to remove sound on vision, the common i.f. amplifier is over favouring the sound channel or the pass band of the vision i.f. strip is too wide.

In either event, the tuning error must be rectified otherwise fine tuner setting will prove to be too critical for everyday use.

If any core slots are worn too shallow for easy manipulation, careful scraping with a medium sized needle will usually increase their depth, but if any core heads are completely broken or "chewed"

remember that slugs are slotted at both ends and by removing its partner from the i.f.t. can, it will invariably show an untouched slot at its opposite end.

Should you find a slug completely jammed with the core "dust", the only remedy is to drill it out with a very fine drill.

If confronted with a bad instance of poor Band I/III balance, it must be emphasised that even seemingly perfect aerials can be the cause.

For instance, the writer once came across an RGD receiver which gave superb BBC results but produced a hardly lockable image on ITA.

After much tuner valve changing and contact cleaning with no avail, it was taken into the workshop for examination.

On the workshop aerial, reception on both bands was perfect and subsequent inspection showed that the inner lead of the common co-ax lead had broken away from the top dipole of the customer's I plus 5 combined aerial.

Then quite a few older models made by Murphy and Alba had separate Band I and Band III sensitivity controls. They were switched in and out of circuit by the rotation of the turret tuner, but if as sometimes happened, the appropriate coils were removed from their normal positions on opposite sides of the switch to adjacent positions, the two bands will be controlled by only one sensitivity control, a distinct disadvantage in areas where Band I/III signal strengths widely differ.

Finally, the coil often found mounted on the aerial panel away from the receiver chassis is purely an i.f. rejector, to prevent any picked-up i.f. frequencies from getting into the receiver and causing interference or patterning that could not then be eliminated, and its setting has no significant effect on sound or vision reception. ■

★ *Component Caused Alignment Faults by G. R. Wilding, page 315, April 1966, P/TV.*

**TV TERMS AND DEFINITIONS**

—continued from page 366

**Cascade Stage**

Not to be confused with "cascade" which implies an arrangement in series connection (i.e. one after the other). Cascade is a form of amplifier used in v.h.f. valve tuners. It utilises a double-triode valve, the cathode of the second section being in d.c. connection with the anode of the first section. Such an arrangement ensures optimum coupling between the two triodes and it also endows the two-triode stage with gain characteristics equal to those of a pentode but with the noise advantage of a triode.

More recent valve tuners use a special high slope single triode, such as the Mullard PC97, instead of the double-triode cascade stage. This is made possible by using the valve in the earthed-cathode mode, thereby achieving a high stage gain. Neutralisation, necessary with earlier v.h.f. triodes in this mode is rendered unnecessary due to the very low grid/anode capacitance of the special triode. This capacitance is in the order of 0.5pF as compared with 2pF and 4pF of the sections of a double-triode cascade valve.

**Channels**

See under Bands I, III, IV and V.

**Cog-Wheel Effect**

The black and white rectangles bordering the test card provide a test for separation of the sync signals from the picture content. Displacement of the vertical content of the card to the left at levels corresponding to the white rectangles is an indication that the sync separator is passing picture signal.

This gives the circle of the test card a cog-wheel appearance. If the displacement is to the right, however, impaired high-frequency response of the circuits immediately preceding the sync separator stage is probably responsible.

**Communal Aerial**

This is a system whereby a single master aerial supplies a number of receivers, avoiding the need for individual aerials. The master aerial is sited in an interference-free elevated area as near as possible to the sets. The aerial signals are amplified and then combined to a single coaxial feeder, from whence they are fed to the sets, through resistive "take-off" pads for matching and attenuating purposes. On long cable runs the signals are further amplified as they become weakened by the attenuation characteristics of the cable.

Part 3 follows next month

# THE SERVICE ENGINEER IN THE HOME

by J. D. Benson

“MANNERS maketh man”. Never was a phrase more apt or applicable than in the case of the service engineer who has been delegated to investigate a faulty television or radio receiver in the customer's home.

The wise dealer or service manager will not only pick the engineer for his technical ability alone but for his capacity to act as personal relations link between customer and business. This is a most important factor and can be the keystone in building up and maintaining a successful business.

What, then, are the qualities to look for when selecting a service engineer to undertake outside work in customers' homes? First he should be neat and clean in appearance, and this does not mean that he has to be a dandy or fop. Clear of speech and with the ability to hold his own counsel and abstain from voicing opinions on any subject which might give offence to the customer.

In particular the engineer must refrain from criticising customers' radio or television equipment which, although it may be obsolete, may hold some particular sentimental value for the owner.

Clothes should be tidy and respectable, a ragged hole in elbows or knees of trousers is not only unsightly but denotes very often slack and slovenly work. If white overall coats are worn then a clean one should be donned before visiting customers. Footwear should also be kept up to scratch and always freed of outside mud or dirt before entering a private dwelling.

These foregoing points may all seem very obvious but it is surprising the number of occasions, especially on a rush job, when these simple points can be overlooked.

The vehicle used for transporting the service engineer is of equal importance whether it be a van or private car. A car or a van with a scarred or rough body is a very poor advertisement for a business and leads to adverse criticism. Whatever type of vehicle is used, adequate interior protection should be provided to obviate damage to cabinets, which are often more prized by the housewife than the contents.

Every journeyman should be equipped with a compact tool carrier. There is nothing worse, from a customer's point of view, than an engineer who arrives clutching armfuls of tools and test gear which are deposited all over the place.

Respect of other people's property is perhaps the first lesson the journeyman learns always remembering that articles which may represent no value to him may be of inestimable value to the owner.

Having arrived at the client's house in good order it is very necessary for the engineer to instil confidence from the word “go”. This can only be accomplished by politeness and a quiet approach, coupled with patience. This last quality is most important and is often stretched to its limits, but a little thought on the subject will soon reveal that it is not always easy for the layman to describe faults in complicated television or radio equipment, for he, the service engineer, himself knows how, very often, it is difficult to diagnose and describe faults.

The television or radio receiver is most often sited in the lounge or dining room-cum-lounge, which in most cases contains valuable furniture and ornaments which are the housewife's pride and joy. Great care should be taken if it is necessary to move any of the furniture or ornaments which, if broken through carelessness, cannot, in many cases, be replaced, especially if they are of sentimental value.

Soldering equipment should be used with infinite care with respect to furniture and surroundings. Scorch marks on costly carpets do not engender good relationships! Dirty hand marks on paintwork are equally offensive.

If the journeyman engineer had only to deal with defective equipment his life would be a happy one, but such is not the case. In quite a number of cases he has to deal with an irate person who heatedly declares that this sort of thing never happens to Mrs. Jones or Mrs. Brown, etc. Patience and tact are called for and experience alone can deal with these eruptions. A few words of praise for a lovely garden, furniture or children, not forgetting household pets, can work wonders.

In mentioning children and household pets, i.e. cats and dogs, we are dealing with two of the heaviest crosses which the visiting engineer has to bear. Dealing first with cats and dogs, they can generally be removed from the scene of action if it is suggested that there is a risk of electric shock should they come into contact with test equipment, etc.

The presence of children whilst an engineer is at work can be very distracting, especially toddlers

who delight in emptying tool bags and opening tins of screws! Again, diplomacy must be used and if it is mentioned that the repair may not be completed in time for a favourite programme if the children continue to run off with tools it will be found to work like magic and the child or children will be removed to other quarters.

The writer has generally been an advocate of returning all receivers to the workshop for repair, but with the increase of rentals and in order to keep down maintenance costs as many repairs as possible should be carried out *in situ*.

The service engineer must at all times be guarded in passing opinions about clients' equipment and comparisons with the latest models, etc., unless the information is requested by the customer. Equally dangerous ground is to pass on information about neighbours' receivers, even when requested.

Conversation with customers should be kept to local topics; religion and politics are taboo if good relationships are to be preserved. It is quite easy with a little practice to guide conversations out of dangerous channels into safe waters such as television programmes, which will generally raise strong protests.

Most customers with television receivers fear the breakdown of the c.r.t., a condition which stems from the days when c.r.t.s were really expensive and only guaranteed for a short period. A few facts and figures regarding the life and price of the modern c.r.t. will soon dispel these fears.

Another common request by clients is: "*How much will it cost?*" Now this is really a sticky one but I have always made it a practice to train engineers in costing so that such queries can be reasonably answered. This practice engenders confidence in the engineer and obviates such remarks as "*I wouldn't have had it done if I had known how much it was going to cost*".

Although some firms employ crews for erecting aerials the majority employ contractors who specialise in the erection of aerials. It may be considered that this aspect of service work is outside the engineer's scope but this is not so. It is the service engineer who will instal the television or radio (f.m.) receiver and it is within his province to make sure that the installation is up to standard in all respects and to report back to his employer any defects that may be present.

Aerial riggers are often responsible for broken slates and tiles unless care is taken. It is up to the service engineer to report such accidents and have the fault rectified if good customer-dealer relationships are to be preserved.

The service engineer's presence in a household is an important one and the golden rule is that he should leave the home as neat and tidy as he found it and finally and of paramount importance—punctuality. Having made an appointment, arrive at the time stated. If by any chance an appointment cannot be kept—and occasions do arise—a message should be sent to the customer stating the reasons and fixing an alternative time.

During my years of journeyman's work I believed the ultimate in customer-dealer relations had been arrived at when upon arrival at a customer's house I was greeted with: "*Well, now it's time to put the kettle on!*" ■

## THE OLYMPIC II — continued from page 349

unit takes about 0.4A. The line output transistor, as it operates in a hard-on or hard-off state, should dissipate negligible heat and remain quite cold.

Before bringing the output transistor into circuit the frequency of the oscillator should be adjusted to be nearly correct. The line hold control VR11 (Fig. 33) should be set to the centre of its travel, and with the core of T1 screwed about two thirds of the way home the potentiometer VR12 (Fig 33) set for the correct frequency as nearly as possible. With the receiver obtaining a programme of reasonable field strength, and the output transistor switched on VR12 should then be set until lock is achieved. If this condition cannot be met, or met only with VR12 near an extremity of its travel, the core of T1 should be adjusted. Alternatively, VR12 can be left at about its mid-setting and T1 core rotated for lock. The "Q" of the tuned circuit is higher with the core more than half-way home, and a larger trigger amplitude is obtained.

Although this time base generator does not radiate as badly as the original one, screening is still necessary since pulse rise and fall times are very fast and some energy does escape. Decoupling must be very thorough and if a capacitor is available (and will fit) of more than 100 $\mu$ F, it may well be used, next to the 5-6 $\Omega$  decoupling resistor where —12.6V enters the oscillator-driver unit. Up to 1000 $\mu$ F may be used, although this may entail the unit continuing to whistle for a second or two after switching off.

### Line lock

Line lock is extremely stable and very hard. So far, since setting up, the prototype has operated for 32 hours, in sessions of up to 2 hours at a time, without any adjustment being required. With a small accumulator as supply, the voltage on load drops from 12.6 to about 10.5 reasonably steadily, and the sync can cope with this. Further use without recharging results in a rapid drop to 9 volts or lower, and sync cannot always be obtained in these circumstances. When set, both line and field controls are semi-permanent and do not require to be readily accessible; this may simplify the layout of the front of the receiver. If the line hold control is not set too far towards the "out of lock" state, it is not possible to observe by inspection whether a station has ceased to radiate at the end of transmission—this is easy with a normal receiver since sync obviously fails and is both seen and heard. However, the absence of this effect could possibly result in the receivers being left switched on all night, and is hardly recommended!

This time, base generator uses more transistors than the original unit of the *Olympic II*. The improvement in performance is so very marked that everyone building the receiver is urged to use it in preference. The actual cost is a few shillings more, but the gain in convenience makes it well worthwhile..

In the near future it is hoped to develop a new audio output stage using no transformers. The need for this was underlined when Messrs. Gilson discontinued the supply of the recommended transformers. The revised audio section will employ Texas Instruments transistors type 2N1308 and 2N1309; a matched pair of these complementary (pnp and npn) devices will be needed. ■



# LETTERS TO THE EDITOR

## YOUR PROBLEMS SOLVED

SIR,—In the “Your Problems Solved” section of *Practical Television* you often refer to such components as R230, C227 or L209. I realise that space is limited but would it not be possible for you to rewrite readers’ letters in order to state the function of each component mentioned. In this way the problems are of general interest to all and not just to those few who can look up the value of the components on the appropriate service sheet.—P. SPARKS (Reigate, Surrey).

*When servicing a television receiver a service sheet is really essential and we assume that most people doing repairs have the appropriate service sheet at hand. If we were to state the function and value of each component mentioned each Problem Solved would take up much more space in the magazine than we are able to allow.—Ed.*

## SCOPE FROM A TV CHASSIS

SIR,—It has recently been brought to my notice that two errors occurred in my article “Scope from a TV Chassis” published in the February issue of *Practical Television*. Both of these errors were in Fig. 5.

Firstly, the EY51 has been shown reversed: the anode and not the cathode should be shown connected to the e.h.t. overwind, i.e. no change is implied in the original wiring.

Secondly, C4 has been shown connected between pins 2 and 3 of V2 instead of pins 2 and 6.

Both these errors were entirely my fault and I should like to convey my apologies to readers for any inconvenience this has caused.—C. J. DORAN (London, S.E.20).

## CAN ANYONE HELP PLEASE?

SIR,—I would like to buy complete issues of *Practical Television* for 1960 to 1964 and also the October, 1965, issue. Can any other readers help me, please?—C. WOODS (177 Chatsworth Road, Stretford, Manchester).

## HAS ANYONE THESE ISSUES?

SIR,—I would be grateful if any readers could supply the following issues of *Practical Television* as I require them to complete my collection:

August and September, 1961; July, August, October, November and December, 1962; January, February, April, June, July, August and September, 1963, and January, 1964.

---

**SPECIAL NOTE:** Will readers please note that we are unable to supply Service Sheets or Circuits of ex-Government apparatus, or of proprietary makes of commercial receivers. We regret that we are also unable to publish letters from readers seeking a source of such apparatus.

The Editor does not necessarily agree with the opinions expressed by his correspondents.

---

I am willing to pay a good price for these copies and will pay any expenses that are incurred.—DAVID WESTCOTT (10 Leighton Road, Southville, Bristol 3).

## DO CHECK THE VALVE

SIR,—For some little while I have had trouble with my Ultra VI917. Although I could get picture and sound perfectly in every detail on ITV channel 9, I could only get sound and an unresolved grey picture on BBC channel 2. Valve voltages, etc, were checked on the tuner valves and found near enough correct to the service sheet, and I concluded that the very few components associated with BBC must have a fault, but yet I could find none.

The PCF80 had been checked by substitution with no difference, and as the PCC84 was only about six months old I really did not suspect it. However, when rummaging through the junk box today, I found a PCC84 which had somehow got in there and I did not know I had one. I substituted this valve in the tuner, waited for ITV to come on—a good picture. I switched to BBC and “lo and behold” there was the picture and sound clear in every detail. I put the original PCC84 back again, and the picture was gone on BBC as before.

Which goes to show. Do check the valve(s) by substitution if possible.—JOHN W. ARMFIELD (Leigh, Lancashire).

## SPARE PARTS

SIR,—In furtherance of my letter published in March *PRACTICAL TELEVISION* concerning spare parts. The response to my offer was gratifying and all the parts have now been sent off. I received over a dozen letters not only requesting parts of the sets I quoted and many others but to my surprise considering the excellence of the bureau run by this journal, seeking technical advice.

I have done my best to answer all the letters, and where possible help out, but could inadvertently have missed someone out in which case I apologise.

Everyone sent more than adequate money for postage and, since I have no desire to profit financially from this, I have decided to send the excess to Oxfam.

Two or three writers indicated to me that they also have spares available and I hope they will be writing to *PRACTICAL TELEVISION* before long.—A RODEN (Welwyn Garden City, Hertfordshire).

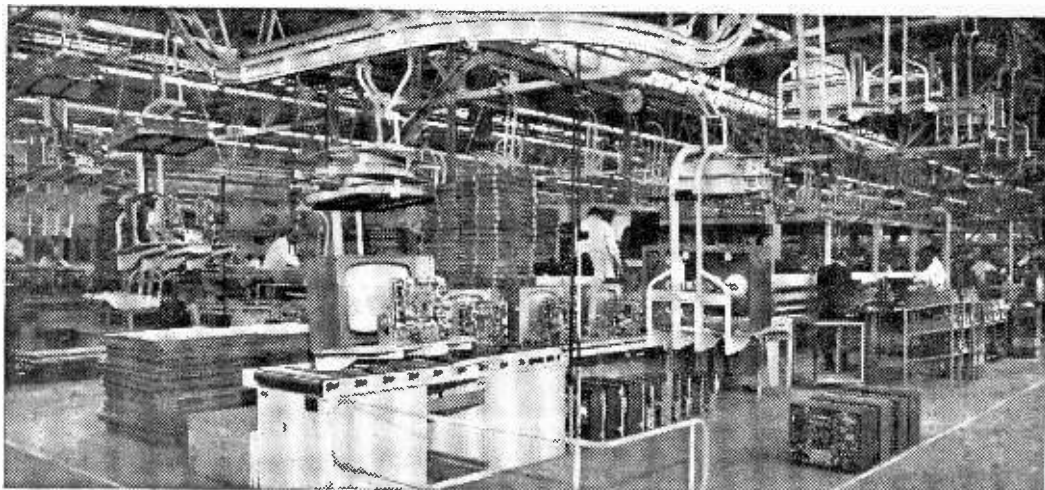

# MEET THE SETMAKERS

PART 4: PROVING THE DESIGN

P. WESTLAND



## Checking the Prototype

**T**HE first prototype model of our new TV receiver-to-be is now in some semblance of working order. The engineer responsible for assembling it has spent two days of intensive trouble-shooting ironing out the bugs.

A couple of leads were mis-connected, and one was left out altogether. One or two slight errors in drawing up the prototype printed boards made all the difference between go and no-go, and two video correction chokes were at odds with each other, and had to be interchanged to smooth out the video response. Mistakes like these can be very time consuming.

Still, the model is working at last, and it is time to take stock of the situation and decide how far we have got, and what remains to be done. Our prototype receiver comprises a number of individual circuits, each of which has been designed in isolation, and which are now being brought together for the first time. Inevitably, a great deal of work is involved in engineering these circuits into one completely integrated design.

Furthermore, the design has to be proved in every detail before it can be released to the factory. If this is neglected, so many troubles will crop up

in production that the assembly lines will grind to a halt. This is final and complete proof of bad engineering. The following list shows the main aspects of the design that have to be proved in detail and finalised:

- 1 *Electrical performance.*
- 2 *The Suitability of the mechanical design.*
- 3 *Electrical and mechanical tolerances.*
- 4 *Reliability.*
- 5 *Safety to BS. 415.*
- 6 *Radiation of interference to BS. 905.*
- 7 *Consolidation of the styling.*

Until the whole design is finally completed, many of these activities will be going on all the time, and a number of prototype models have been assembled for this purpose. Obviously we cannot go skipping about from lab to lab, out in the field and back again, so we will take a look at each item in turn. To most of us the electrical performance is the most interesting aspect of the design, so we will clear the decks by going through the rest of the list first, and then we shall be free to go out on field tests.

## The Mechanical Design

The structure of our new receiver must be strong enough to withstand transport hazards; easy to get at for servicing; durable in use; and easy to operate.

From the transport point of view it is of no use designing a very strong chassis if the packing is too inadequate to protect the outside of the cabinet from damage. On the other hand, sufficient packing to prevent a flimsy chassis from vibrating to pieces is prohibitively expensive.

A proper balance must be reached between the quality of the packing and the strength of the chassis. The final design is proved by vibrating

a properly packed complete receiver on a special jig designed to simulate the hazards of normal (and abnormal) transport.

Drop tests from premeditated heights and at all angles will be carried out, and then the receiver is unpacked and inspected. Any signs of cabinet weakness, or any tendency for mechanical items to work loose, will receive immediate attention. It is a test of the packing too, and weak cartons or soft buffers must be strengthened.

The question of easy servicing is a matter for common sense, imagination and the advice of the service department. Most of the problems will have been foreseen at the basic design stage, and little remains to be done.

Turning to the customer's angle, the durability of switch mechanisms and any other moving parts will be checked by prolonged life tests in a special testing laboratory. Care is taken also to see that such things as tuner knobs and system switch push buttons can all be operated easily.

#### Tolerances

Imagine turning out a thousand or more television receivers every working day only to find that the knobs would not fit on to the spindles; the c.r.t. would not fit the hole in the front of the cabinet; the live or field hold was off the end of the pot, or the i.f.'s were oscillating! All caused by an adverse combination of tolerances.

It is absolutely essential to the smooth running of any assembly process that the mechanical and electrical tolerances are chosen, or allowed for, so that any combination of components are compatible, and give a satisfactory result.

All mechanical tolerances have to be added up and checked on every drawing issued by the drawing office. Similarly a number of prototype models are measured electrically in every detail to ensure that adverse combinations of tolerances do not cause the performance to be outside the specified limits.

The measurements are legion, but here are a few examples: V.I.F. response stage by stage—overall, and each stage added together, s.i.f. responses similarly; a.f. response; a.f. distortion; a.f. output. Line and field oscillator hold and free running ranges. E.H.T.; e.h.t. regulation; line and field scan amplitudes and linearities. Sensitivities on each channel, sound and vision, 405 and 625.

#### Reliability

The essence of reliability is to ensure that every single component is within its rating under all more or less reasonable conditions of receiver adjustment; with the mains input on its top limit of tolerance, and the receiver working in an ambient (or air) temperature of 95°F (35°C).

This means that every component has to be measured for voltage, current, power dissipation (as appropriate) and temperature under a variety of working conditions, and the results checked against the manufacturers recommendations.

It does not need much imagination to see what an immense amount of work is involved, but every responsible setmaker has to do it. Failure to do so will soon be shown by angry dealers, and the service returns for spare parts.

#### Safety

Problems of safety were discussed in some detail in the October and November 1964 issues of PRACTICAL TELEVISION. Little remains to be said except that all these matters, too, have to be checked in every detail. Another time-consuming job.

#### Interference

The British Standard specification BS905 describes the methods of measurement and the maximum permissible limits of electrostatic, electromagnetic and mains-borne radiation. All these have to be carefully measured together with the level of radiation of harmonics of the v.h.f. tuner oscillator which lie in the u.h.f. bands. Any of these could cause interference on a neighbouring radio or TV receiver.

#### Styling

The sales manager will by now have chosen the styling presentation for our next season's range of models. However in some cases he will in all probability have asked for minor changes of colour or trim, or for new suggestions about legs or stands. The stylists will be busy arranging for final styling models to be made which are complete and accurate in every detail.

These will then be photographed so that sales brochures, pamphlets and other promotional material can be prepared by the publicity and advertising boys.



Laboratory Tests

Now it is time to return to our prototype receiver and begin the task of checking its performance from every possible angle, and under a wide variety of conditions. It is only fair to warn you that you are going to be surprised at the large number of faults and defects that our testing will reveal. This is in spite of the fact that a number of very competent engineers have spent a great deal of time designing all the individual circuits.

The cause of our troubles is partly that the circuits have never been connected together into one cohesive design before, and partly because the layout of the printed boards had to be started before the circuit design was finished in order that the overall design process could be completed by the proper date. As each batch of faults is revealed, modifications will be devised, and the prototypes brought up to date.

Another important point is that many defects can only be found, or seen in proper perspective, during the process of field testing, and seldom come to light during circuit design in the laboratory.

The author has a private check list of over 100

items that should be examined and approved before the electrical performance can be passed as satisfactory. Let us make a start on this and see how far we get.

#### Testing in the Lab.

A group of engineers stand around behind us, each one anxious about his own particular piece of circuitry. A 405-line factory test pattern is plugged in and we adjust the controls to give a picture of the correct size; with optimum linearity, correctly synchronised, and properly set up for contrast and brightness. We adjust the fine tuning for best picture quality and then give it a quick check.

**Definition:** OK up to 2.5Mc/s, but the 2.75 Mc/s bars of the test pattern can hardly be seen. Spot quality quite good over most of the picture area, but the inevitable small amount of deflection defocusing in the corners.

**Overshoots:** Clearly visible but not too obtrusive (see Fig. 1).

**Preshoots:** None.

**Rings:** A bit nasty opposite the 2.5Mc/s bars (see Fig 3).

**Smears:** We turn the brightness down until the picture is almost invisible. The 2.5Mc/s bars disappear first, followed smoothly by the 2.0, 1.5 and 1.0 Mc/s bars. No obvious bumps in the video response, but a white line shows at the edge of the block bar of the test pattern. No smears here, but confirmation of the overshoots (see Fig. 4).

**Frame linearity:** OK over most of the picture, but we cannot adjust the top inch or so properly.

**Line linearity:** Quite good. No problem here. This will do for a start, and now we check the controls.

**Brightness:** Maximum adjustment will not quite give us a big enough range for all likely conditions of use.

**Contrast:** Plenty of range, and the black level only changes slightly.

**Volume:** Plenty, with hardly any hum. No undue distortion.

**405 Line hold:** Adjustment rather critical. Judging by the pattern of break-up the free running range is OK but the pull-in range is rather small.

**Field hold:** Hold range OK, but the free running range seems too small. We might have tolerance trouble here in production. Going from end to end of the hold range we observe that the interlace is generally quite good, but slight pairing occurs at one or two points. Perhaps in places we are synchronising on the second or third field sync pulse instead of always on the first.

**Line amplitude:** Maximum scan OK but at the minimum position we can hardly underscan the picture. Tolerance trouble again.

**Field amplitude:** Maximum scan excessive; minimum scan OK.

**Fine Tuning again:** Adjustment for best picture is rather critical. The overshoots change as we tune, and disappear with a fair degree of mistuning. The rings are unaffected.

#### Conclusions

On the whole, we are off to a fair start. The control problems are a matter for routine circuit measurement and adjustment. Since the overshoots change with tuning, they are an i.f. phenomenon

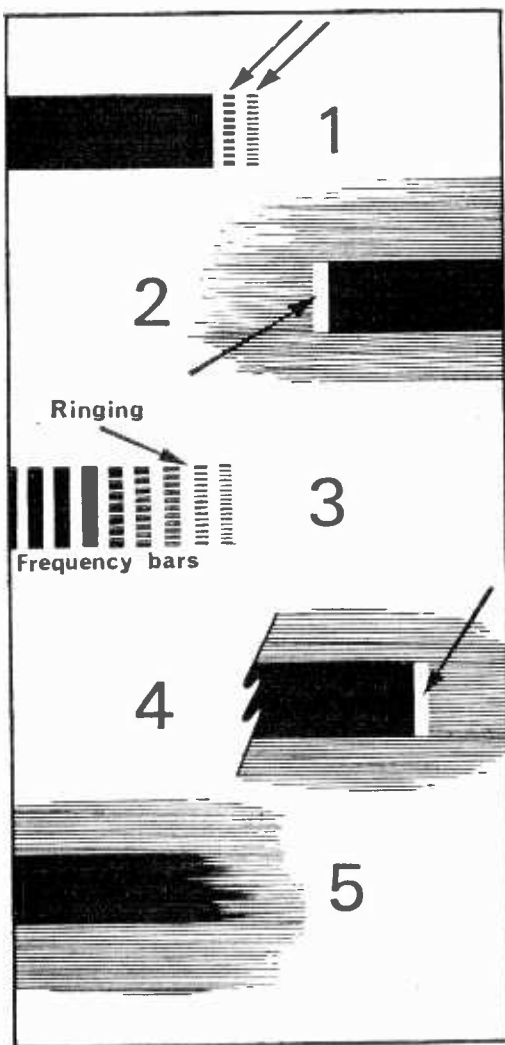

How to use a test card for assessing picture quality. Fig. 1—Severe overshoot. Fig. 2—Preshoot. Fig. 3—Severe ringing. Fig. 4—Overshoots show also at low brightness levels. Fig. 5—Smearing shows most clearly at low brightness.

and a lower carrier attenuation, or change to the shape of the flank of the i.f. passband near the carrier, will probably overcome the trouble.

The rings do not change with tuning, and are almost certainly caused by incorrect video response. Since the response is smooth, and we have no picture information above 2.5Mc/s, it is likely that the video response falls off too abruptly at 2.5Mc/s and the resulting poor phase response is causing the ringing.

In general, any bump or discontinuity in the amplitude/frequency response of the i.f. or video



passbands will cause a non-linear phase/frequency response, and since different frequencies are delayed by different amounts in time, preshoots, overshoots, rings or smears can be caused.

### 625 Line Testing

We set up the picture and sound on 405 lines and then switch over to 625. (Push button a bit stiff.)

*System equalisation:* Hello! The black level has changed markedly, and the brightness control needs adjusting. Contrast OK; volume OK.

*Picture quality:* No preshoots or overshoots; only a trace of ringing, but signs of smeariness. Definition OK. We turn down the brightness and observe that the video response is quite smooth, but smearing is very noticeable. (See Fig. 5.)

*Field hold:* Interlase good over almost the entire hold range. The other characteristics will, of course, be the same as on 405 lines.

*Line amplitude:* The line scan is too large and the picture is off centre. The line transformer needs slight alteration, and the flywheel needs adjustment to centre up the picture.

*Line linearity:* Not quite so good, but still pretty fair. A compromise has to be accepted, and this is not a bad one.

*Switch-off:* Ah, a bright spot appears in the centre of the screen. Not particularly harmful, but it looks bad to a customer. We must improve the switch-off spot suppression circuit.

### Conclusions

Some more routine improvements needed, but nothing that will affect the basic design of the receiver. The 625 carrier alternation may be a bit too small, and hence the smears: the change of black level with system switching must definitely be improved.

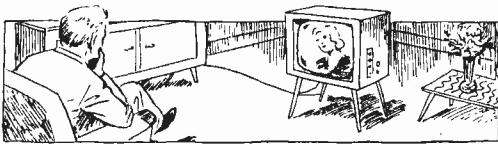

### Tests at Home

The engineers have been busy making improvements in time for us to take the prototype home this evening. The i.f. responses have not been touched, because it is a time-consuming business in that anything done to the 405 line passband will probably affect the 625 performance as well. Also, the smears and overshoots may have been partly caused by differences between the factory test pattern, and BBC and ITA transmission characteristics. The optimum choice of passband shape is very critical.

Switch on to the BBC. Good heavens! Hear that hum! How could we possibly have missed it in the lab? It is a strange fact, but we nearly always do. It is partly due to the background noises in the lab, and partly caused by the psychological effect of our environment.

We alter the field hold control, and as the picture starts to slip the hum changes its note. It is clearly

caused by pick-up of field timebase pulses, or field ripple on the a.f. h.t. line.

*Fine tuning:* We adjust the 405 line fine tuning and confirm that it is critical. This time, however, it is due to vision or sound. A buzz occurs as we detour slightly from the correct position. Clearly the sound rejection notch is deep enough, but too narrow.

*Picture quality:* The defects found in the lab. are not so bad at home with a good aerial and proper transmission. They do exist however. We notice that the u.h.f. fine tuning has some backlash. We must tell the mechanical design boys.

*Controls:* We check the controls again and find a new snag. The BBC signal is very strong, and if we turn the contrast control up to maximum the picture disappears and will not come back. We change channel, reduce the contrast, and change back again. It was "a.g.c. lock out" caused by overloading before the a.g.c. could catch up with it.

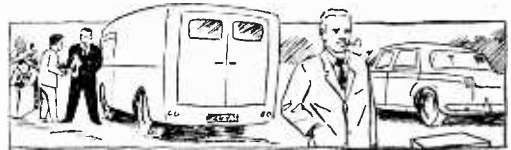

### Field Tests

Next morning, we take the receiver back to the lab, and announce our discoveries. While some more intensive trouble shooting goes on, we plan our field test. We know a good place on the South coast where we can get channels 11, 9, 3, 2, and 1 at signal strengths varying from very strong to almost completely unusable. An ideal test site.

We organise transport; paper work to get all our staff out of the works again; a receiver to use for comparison purposes, and decide which staff shall come. You cannot test properly with more than about four people present.

### On the Site

You explain patiently to your wife that you will not need your boots for the "field test", and make an early start. Down at our test site, we set up the signal strength measuring gear and note the results on each channel. Meanwhile, the two receivers are set up side by side with an equal amount of light falling on each.

Let us pass over the results of the strong signal tests, except to comment that we saw a trace of 3.5Mc/s S to V carrier beat pattern, and that our previous picture quality assessments were confirmed, and concentrate on fringe area testing. We are interested primarily in synchronising performance, sensitivity, and spurious interferences on the picture when the receiver is operating at full gain.

We tune into a weak but just usable signal and adjust both receivers to give as near identical pictures as possible. We want to compare picture noise, and it is essential to have equal contrast and brightness. Our comparison receiver, whose performance is well-known to us, shows quite noticeable noise at this level of signal, as we expected. Our new design is better and we attribute this to

the improved type of v.h.f. tuner with a better noise factor that we have fitted.

So far so good. The line synchronisation, however, is not up to standard, and the vertical lines of the test card are slightly more ragged than on the comparison receiver. We check the field hold and the range is rather small, making adjustment critical. A clue here. We must check the slicing level of the sync separator when we get back to the lab. This can almost certainly be improved.

Some impulse interference suddenly starts up, and both field and line synchronisation are affected. Further confirmation of our diagnosis. The white spots on the picture do not spread into smeary streaks, and the black level hardly changes. Good. We turn both contrast controls up to maximum and note that on our comparison receiver the picture contrast hardly changes, but on our new one we can almost overload the picture. Plenty of gain in hand here.

Now we, off-centre both pictures so that we can see the beginning of the raster, and then check each channel, with and without an aerial, looking for spurious effects when the receivers are operating at, or near, full gain. Our comparison receiver is OK, as we expected, but our new model shows a bright line at the edge of the raster on one or two channels. This is caused by r.f. harmonics of the boost diode switching-on surge being picked up by the tuner. An r.f. choke in the cathode will cure this.

On one channel a thin vertical line of interference can be seen faintly near the middle of the picture. This is Barkhausen interference caused by a v.h.f. oscillation in the line output valve. Changing the valve cures the trouble and it was very faint anyway. Still, we will check this again on future tests.

Another burst of impulse interference occurs and someone reaches hastily for the volume controls, and turns up the sound on each receiver in turn,

We close our eyes and listen carefully for the "plops". Yes, the sound interference limiters are obviously effective, but our new design is not behaving quite as well as the old. We must try increasing the circuit time-constant to improve the limiting action in order to match the increase in sound and vision sensitivity.

And so the tests go on. After several hours of careful concentration, much discussion and diagnosis, checks and cross-checks, we are tired and it is time to drive home. It has been a useful day's work.

#### And Yet More Tests

This has only been the beginning of our field test programme. A preliminary canter in order to find some of the more obvious faults so that we can clear the decks for a more critical assessment after various modifications have been devised and built in to our prototype models. Further tests have to be done specifically on u.h.f. transmissions and then system switching tests between u.h.f. and v.h.f. channels of widely differing signal strengths.

After this come tests, perhaps high up on the South Downs, on adjacent channels of equal strength to check the adjacent channel rejection performance.

When we have cured all the defects, we shall go out looking for more trouble. We try different combinations of test conditions with different receivers. Perhaps we shall visit Birmingham, or Manchester, or the Potteries; anywhere that may show up something new.

Troubles found and overcome inspire confidence in the final design. When we can find no more our job is done. Then we *know* that our new receiver is going to be all right, and that is what we have had to prove.

Next Month: Conclusion

## LC PICOMETER

—continued from page 359

stray capacitance being measured as long as any such shunt paths are always broken at a point which is "cold", i.e. at chassis potential, with respect to a.c. signals. Thus it is important to disconnect the anode load resistor in the cited example at the h.t. end, not at the anode end.

The shunt paths in grid circuits are generally of much higher impedance, since grid leaks are mostly of the order of 100k $\Omega$  to 1M $\Omega$  or more. It may not be necessary to disconnect these when measuring the total stray capacitance in a grid circuit of an amplifier stage. If such measurements are made whilst the circuit is running, it is most important to avoid connecting the grid directly to an "X" terminal of the picometer where this would lead to shorting-out of a grid bias supply or some other function determining the operating point of the stage. Wherever there is a danger thereof, interpose a capacitor which is at least 100 times as large as the expected stray capacitance (in general, 0.01 $\mu$ F would be satisfactory).

Finally, it is necessary to bear in mind the points made earlier in this article regarding voltage-dependent capacitance components when measuring

stray capacitances in semiconductor circuits. For example, if an efficient low-amplitude tunnel dipper is not available for exciting the picometer, it is better to disconnect the collector when measuring the total stray capacitance in a collector circuit. Then proceed as described above for an anode circuit, disconnecting the collector load resistor at the supply end if necessary too. Look up the collector output capacitance of the particular transistor for the prevailing operating point in the maker's data, and add this to the measured value obtained for the other strays, to obtain the total stray capacitance in the collector circuit.

A knowledge of circuit stray capacitances is of vital importance during design work when it is desired to compensate the effects thereof, for example in order to achieve maximum bandwidth in an oscilloscope or video amplifier, or to obtain optimum response in a pulse circuit for logical functions. The simplest method of compensation is to insert a cathode or emitter resistor in a normal valve amplifier or base-input/collector-output transistor amplifier stage respectively, and then to shunt the inserted resistor with a selected capacitance such that cathode and anode time constants (C x R) or emitter and collector time constants are equal. This gives optimum bandwidth and transient response under the given conditions without resorting to further improvements with the help of more complicated measures involving peaking inductances as well. ■

# TRADE NEWS • TRADE NEWS TRADE NEWS • TRADE NEWS TRADE NEWS • TRADE NEWS TRADE NEWS • TRADE NEWS

## PYE CONTINENTAL COMPACT

AT 62 guineas the new "Continental Compact", model 32/F, is a fully dual-standard flywheel sync model. Housed in a "fibreform" cabinet in dark grey Suwide, this receiver is the portable companion to the now well-established "Mini-TV". Pymatic tuning—the fully transistorised integrated tuner, gives instant push-button selection of any programme on 405 or 625.

The c.r.t. is a 16in. electrostatic focussing type, fitted with a new Cornehl cap implosion guard which completely seals the tube face against dust, thus ensuring constant crystal-clear viewing.

The dual-standard i.f. panel is small and compact and is mounted at the rear of the integrated tuner. The i.f. amplifiers are fully transistorised and are capable of handling sufficient output from the vision and sound detectors to drive the video and audio amplifiers. The required bandwidth and shape for the vision channel is obtained by stagger tuning and by the use of various rejector circuits.

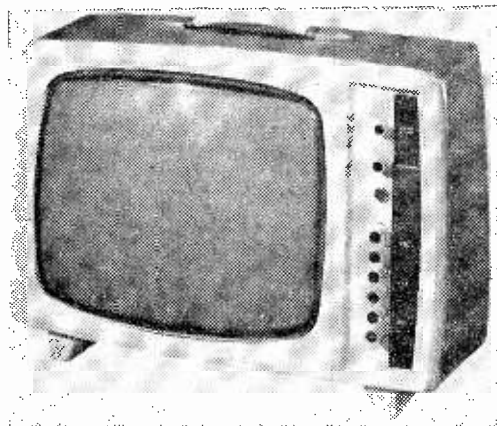

The gain of both vision and sound i.f. amplifiers is controlled automatically.

A clip-on aerial is available as an optional extra at £1 1s.

## "NEW STYLE" FOR HEATHKIT MILLIVOLT-METER

THE Heathkit valve millivoltmeter Model AV-3U is the latest instrument in the range to be re-styled. No changes have been made to the very reliable circuit of this instrument, but an external "face lift" has brought the AV-3U into line with the current "professional" styling of other Heathkit models.

A prominent dark grey relief against the silver grey background of the front panel raises the

appearance of the AV-3U to the same high standard as its specification. White lettering is used, for clarity, and the single control knob is now black with a spun aluminium insert. The whole is housed in a charcoal grey cabinet.

For £16 10s., in kit form, Heathkit offer this "new style" AV-3U which has a sensitivity of: 0.01V to 300V f.s.d. in 10 ranges, and an accuracy of within 5% full scale.

A fully assembled and tested instrument is available at £22 18s.

## FERGUSON FAMILY PORTABLE

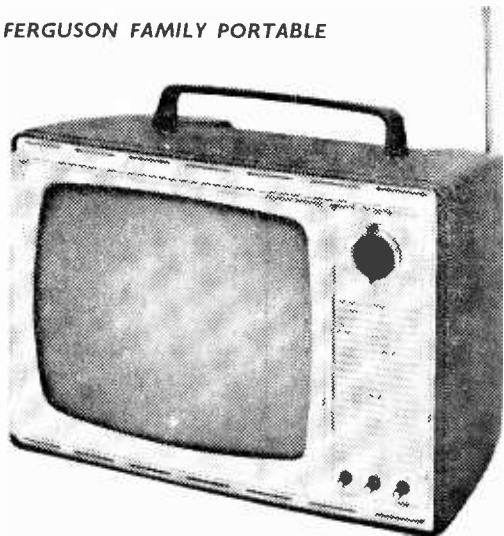

THE Ferguson 3639 is a portable mains operated receiver for reception of 405-line transmission on bands I and III. It uses a 12in. "T" band picture tube and performs satisfactorily on its own built-in telescopic aerial in areas of average signal strength.

In the vision channel, two i.f. stages, a germanium diode detector and a video stage are employed. AGC voltages are developed by the synchronising pulse separator and clamed by a selenium diode.

The sound path is through one common i.f. stage and one narrow band i.f. stage. The germanium detector diode and noise-limiting triode-pentode audio stage feed the 700 line loudspeaker with an audio power output of 500mW.

The receiver is designed to operate on 240V a.c., two power silicon rectifiers providing the h.t. line voltage.

The 3639 weighs 15lbs. and costs 39½ guineas.

## CATALOGUE FROM HENRY'S RADIO

FROM Henry's Radio Ltd., comes their 1966 catalogue. It comprises 152 pages fully detailed and illustrated with over 5,000 stock items. Components, valves, quartz crystals, semi-conductors, test equipment, high fidelity equipment and accessories, ready-built units and kits to build are but a few of the items listed.

Page 2 has three discount vouchers for retail and mail order customers, so that when these are used the catalogue will have cost the purchaser nothing.

The price is 6s. post paid and copies may be obtained from Messrs. Henry's Radio Ltd., 303 Edgware Road, London, W.2.



# LAWSON BRAND NEW CATHODE RAY TUBES

The rapidly increasing demand for a complete range of new tubes of the very highest quality is now being met by the new Lawson "CENTURY 99" range of television tubes.

### SPECIFICATION:

The new "Century 99" range of C.R.T.s are the products of Britain's premier C.R.T. manufacturers. All types are exact replacements, manufactured to the original specification, but incorporating the very latest design improvements to give superb performance, coupled with maximum reliability and very long life.

"Century 99" C.R.T.s, available as direct replacements for the following makes and types

MULLARD		MAZDA		BRIMAR		EMISCOPE & EMITRON		GEC and COSOR Also ENGLISH ELECTRIC	
MW43/69	AW36-80	CRM121	CME1901	C12FM	C17SM	4/14	14K1	14K1	14K1
MW43/64	AW36-21	CRM123	CME1902	C14FM	C197A	4/15	17K1	17K1	17K1
MW36/24		CRM122	CME1903	C14GM	C19 16A	4/15G	17K3	17K3	17K3
MW31/74		CRM124	CME2101	C14HM	C19AH	5/2	21K1	21K1	21K1
MW31/16		CRM141	CME2104	C14LM	C19AK	5/2T	7102A	7102A	7102A
MW43/80		CRM142	CME2301	C14PM	C21/1A	5/3T	7201A	7201A	7201A
MW36/44		CRM143	CME2302	C171A	C217A	5/3	7203A	7203A	7203A
MW53/80	A47-13W	CRM144	CME2303	C174A	C21AA	5/3T	7204A	7204A	7204A
MW53/20	A59-16W	CRM153		C175A	C21HM	5/3T	7205A	7205A	7205A
MW43/43	A59-13W	CRM171		C177A	C21KM	14KP4	7401A	7401A	7401A
AW59-91		CRM172		C17A	C21NM	17ARP4	7405A	7405A	7405A
AW59-90		CRM173		C17AF	C21SM	17ASP4	7406A	7406A	7406A
AW53-89		CRM211	CME1906	C17BM	C21TM	17AYP4	7501A	7501A	7501A
AW53-88		CRM212	CME2306	C17FM	C23-7A	21CJP4	7502A	7502A	7502A
AW53-80		CME141		C17GM	C23-TA	SE14/70	7503A	7503A	7503A
AW47-91		CME142		C17HM	C23AG	SE17/70	7504A	7504A	7504A
AW47-90		CME1702		C17JM	C23AK		7601A	7601A	7601A
AW43-89		CME1703		C17LM			7701A	7701A	7701A
AW43-88		CME1705		C17PM					
AW43-80		CME1706							

12" ... £4.10.0  
14" ... £5.10.0  
17" ... £5.19.0  
19"-21" £7.15.0

Terms:  
C.O.D.  
or C.W.O.  
  
Carr. and  
Ins. 8/6

**2 YEARS FULL REPLACEMENT GUARANTEE**  
Complete fitting instructions supplied

**LAWSON TUBES**  
STATION ESTATE, MALVERN,  
Offices:  
18 CHURCHDOWN ROAD,  
MALVERN,  
MALVERN 2100

## FIRST-CLASS RADIO AND T/V COURSES... GET A CERTIFICATE!

After brief, intensely interesting study—undertaken at home in your spare time—YOU can secure a recognised qualification or extend your knowledge of Radio and TV. Let us show you how.

### FREE GUIDE

The New Free Guide contains 120 pages of information of the greatest importance to both the amateur and the man employed in the radio industry. Chambers College provides first rate postal courses for Radio Amateurs' Exam., R.T.E.B. Servicing Cert., C. & C. Telecoms., A.M.I.E.R.E. Guide also gives details of range of diploma courses in Radio/TV Servicing, Electronics and other branches of engineering, together with particulars of our remarkable terms of

**Satisfaction or refund of fee**  
Write now for your copy of this invaluable publication. It may well prove to be the turning point in your career.

**FOUNDED 1885—OVER 150,000 SUCCESSSES**

### CHAMBERS COLLEGE

(Incorp. National Inst. of Engineering)  
(Dept. 844V), 148 HOLBORN  
LONDON, E.C.1

## NEW VALVES!

Guaranteed Set Tested  
24 HOUR SERVICE

1R5, 1S5, 1T4, 3S4, 3V4, DAF91, DF91, DK91, DL32, DL34, SET OF 4, 14/8.					
DAF96, DF96, DK96, DL96, SET OF 4, 23/6.					
1R5	4/-	EBF80	5/9	PL36	9/-
1S5	3/9	EBF89	5/9	PL81	6/6
1T4	2/9	ECC81	3/3	PL82	5/1-
3S4	4/3	ECC82	4/6	PL83	5/1-
3V4	5/-	ECC83	4/6	PL84	6/-
6K7G	1/3	ECC85	5/3	PY32	8/9
6K8G	3/3	ECH35	5/9	PY33	8/9
6Q7G	6/-	ECH42	7/9	PY80	4/9
6V6G	3/-	ECL81	5/6	PY81	5/-
10C2	11/-	ECL80	5/11	PY82	4/9
20L1	11/-	ECL82	6/6	PY83	5/3
20P3	10/6	ECL86	8/-	PY800	5/11
20P4	13/-	EP39	3/6	R20	12/6
30FL1	9/3	EP41	5/9	U25	8/3
30L15	9/9	EP80	4/3	U26	8/6
30FL3	10/3	EP85	4/6	U91	9/6
CL33	8/6	EP86	6/6	U301	10/6
DAC32	6/9	EP89	4/3	U801	14/9
DAF91	3/9	EP91	2/9	UABC80	5/-
DAF96	5/11	EL33	6/3	UAF42	6/11
DF33	7/6	EL41	7/6	UBC41	6/6
DF91	2/9	EL84	4/6	UBF80	5/6
DF96	5/11	EY51	5/11	UBF89	5/9
DK32	7/-	EY86	5/11	UCC94	7/4
DK91	4/-	EZ49	5/6	UCC85	6/-
DK92	7/9	EZ80	3/9	UCP80	8/3
DK96	6/3	EZ81	4/3	UCH42	7/9
DL33	6/6	KT61	6/3	UCI81	6/-
DL35	4/9	N76	14/6	UCL82	7/-
DL92	4/3	PCC84	5/6	UCL83	9/-
DL94	5/-	PCC89	10/3	UF41	6/6
DL96	5/11	PCF87	6/6	UF89	5/6
DX86	6/3	PCF82	5/9	UL41	7/9
DX87	6/9	PCF85	8/-	UL84	5/0
EABC80	5/6	PCL82	6/6	UY11	4/3
EP91	1/9	PCL83	8/9	UY95	4/9
EB3C11	6/3	PCL84	7/6	Z77	2/9

Postage on 1 valve 6d. extra. On 2 valves or more, postage 6d. per valve extra. Any parcel insured against damage in transit 6d. extra.

Office address, no callers.

**GERALD BERNARD**  
83 OSBALDESTON ROAD  
STOKE NEWINGTON  
LONDON N.16

## BBC2 (625 LINE) TV AERIALS

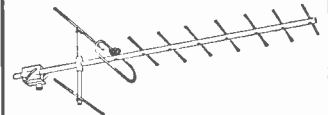

Mast Mounting Arrays, 9 element, 45/-; wide spaced high gain, 11 element, 55/-; 14 element, 62/6. Wall Mounting with Cranked Arm 9 element 60/-; wide spaced high gain, 11 element 67/6; 14 element 75/-; Chimney Arrays Complete, 9 element, 72/-; wide spaced high gain, 11 element, 80/-; 14 element 87/6. Loft Arrays, 7 element, 32/6; wide spaced high gain, 11 element, with TILING Arm, 62/6; 14 element 70/-; All high gain units have special Multi-rod Reflector. Low loss Co-axial cable, 1/8 per yard. UHF transistor pre-amps from 75/-.

## BBC • ITV • F.M. AERIALS

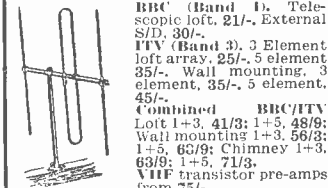

BBC (Band B) Telescopic loft, 21/-; External S/D, 30/-.  
ITV (Band 3) 3 Element loft array, 25/-; 5 element 35/-; Wall mounting, 3 element, 35/-; 5 element, 45/-.  
Combined BBC/ITV Loft 1+3, 41/3; 1+5, 48/9; Wall mounting 1+3, 56/3; 1+5, 63/9; Chimney 1+3, 63/9; 1+5, 71/3.  
VHF transistor pre-amps from 75/-.

F.M. (Band 2) Loft S/D, 12/6. "H", 30/-; 3 element, 52/6. External units available. Co-ax. cable 8d. yd., Co-ax. plugs, 1/3. Outlet boxes, 4/6. Distro Cross-over boxes, 12/6. C.W.O. or C.O.D. P. & P. 4/6. Send 6d. stamps for illustrated lists.

QUOTATIONS FOR SPECIAL ARRAYS AVAILABLE ON REQUEST

**K.V.A. ELECTRONICS** (Dept. P.T.)  
27 Central Parade, New Addington,  
Surrey. LOD 2266

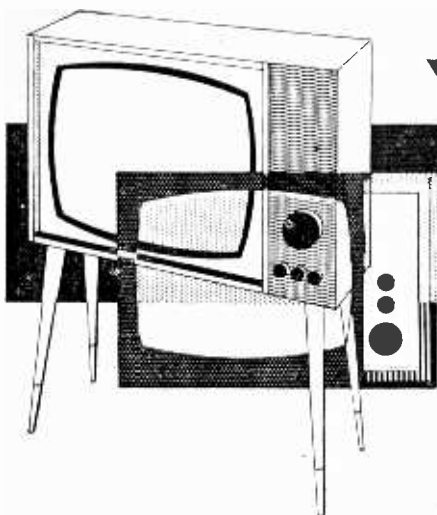

# Your Problems Solved

Whilst we are always pleased to assist readers with their technical difficulties, we regret that we are unable to supply diagrams or provide instructions for modifying surplus equipment. We cannot supply alternative details for constructional articles which appear in these pages. **WE CANNOT UNDERTAKE TO ANSWER QUERIES OVER THE TELEPHONE.** The coupon from p. 381 must be attached to all Queries, and a stamped and addressed envelope must be enclosed.

## ULTRA 17-80

The screen is blank. I have checked valves 30 P19, V191, U26 (new). All associated capacitors, resistors, peaking chokes, and continuity through line output transformer.—P. G. Thornton (Whitstable).

If there is no h.t. voltage at the tops of the line valves, *open-circuit* in the primary of the line output transformer or trouble in the booster diode supply circuit could be responsible. However, since the neon lights when held near the LOT, we feel that h.t. must be present at the valves. In this event, shorting turns in the LOT could be damping oscillations and severely cutting down the pulse voltage and consequently the e.h.t. voltage. A conclusive test for a suspect transformer lies in its substitution. There is no other simple way of determining its goodness.

## FERGUSON 3017

I cannot centralise the picture to the extent of 2 inches from the right of the tube.

The core of the bottom coil is fully extended and the magnet is touching the top coil, leaving no adjustment.—W. Alexander (London, S.E.9).

The centring adjustment is the knob on top of the focusing assembly. To move the picture sideways, rotate the knob. Check the PL81 line output valve, its screen feed resistor to pin 8 and if necessary the PY32 h.t. rectifier.

## MARCONIPHONE 4610

On being fitted with a u.h.f. tuner being troubled with a loss of frame hold only on BBC-2; the frame hold control having no effect and not being at extreme ends of its travel, I have changed valves No. 6 (PCF80) No. 7 (ECC804) No. 13 (PCL85) and both valves in u.h.f. tuner; also W2 a.g.c. overload protection with no improvement. I can

improve the hold by connecting an extra 100 $\mu$ F electrolytic on h.t. rail at R123 as per service sheet. I feel, however, h.t. smoothing is not the basic fault as the set is OK on BBC-1 and ITV. May I add the BBC-2 signal is not weak.—J. H. Wilson (St. Helens, Lancs.).

The BBC transmissions are not locked on the field to the 50c/s mains system. This means that any h.t. ripple would be likely to upset the field lock on 625-line standard while being almost unnoticeable on the 405-line standard. The fact that the 625-line hold improves when the h.t. smoothing is enlarged would appear to prove this point. There is no switching in the field time-base, but a fault in the sync separator or video amplifier stage may aggravate the trouble on 625 lines.

## ULTRA V1781

Fault similar to TEST CASE No. 38. Solved in your February issue for the Ferranti Model.

I have changed the U191 and checked the d.c. valves of T2, and for signs of leakage from condensers C70, C69, C72 and C71. C66 showed a pretty low resistance and has changed. Slight blue discharge in the 30P4.

Operated with minimum brilliance the fault does not show itself and the picture is viewable; turn the control up to normal viewing level and the discharge in the pulse voltage circuit commences. No sign of smoke, smell or arcing.—G. Gaunt (Lancaster).

Since in your case the effect does not commence until the tube is taking a normal beam current, and that the discharge is not present at reduced brightness, it would imply that the tube itself has some bearing on the matter. Check the connection from the e.h.t. rectifier to the tube final anode. A faulty gun assembly in the tube could be responsible in which case tube replacement would be necessary. However, the line output stage is loaded when the beam current is increased, and a weakness in this section or in the line output transformer would cause the trouble.

**FERGUSON 305T**

Could you tell me how to remove the frame pulse bars which are visible at the top left-hand side of the picture?—R. Purdy (Brighton 1, Sussex).

If the lines are true pulse and bar they can be removed by speeding up the field retrace period.

This can be done by reducing the value of the 68k $\Omega$  resistor to pin 9 of the PCL82 to 47k $\Omega$  or, if this is not enough, reducing the 820 $\Omega$  cathode resistor (pin 8) to 470 $\Omega$ .

**PHILIPS 9170**

The BBC picture fades away several times during the programme and if the station tuner is moved it comes back again.

The ITV picture acts the same way. Sometimes the picture does not come on when the station number is set on the tuner.—J. Toolan (Croydon, Surrey).

You will have to check the tuner unit contacts and examine the wiring for dry joints, etc. There is no way that we can pinpoint the fault as only examination, and this under working conditions, can reveal the cause of the trouble.

**ALBA T436**

The picture collapsed to  $\frac{1}{2}$  in. horizontal line. Turning the height control sharply would open it out but now it fails to do so. I have changed the PCL82 frame oscillator, the PCF80 and ECL80 and the height control and checked the transformer connected to it but the fault still persists.—J. Hurley (Merthyr Tydfil, Glamorgan).

Voltage checks on the V12 (PCL82) valve base should show h.t. at pins 6, 7 and 9 with bias voltage of 15V at pin 2. If these are in order check the 0.5 $\mu$ F coupling capacitor and hold circuit. Also check the field deflection coils for continuity.

**PHILIPS 3164**

Bands I and III are normal. On BBC-2 the vertical hold fails to hold the frame for any length of time; slipping occurs in an upward direction. There is also a tendency to line tearing.

Signal strength appears to be ample as the brightness has to be turned down when changing from channels 1 and 9. The aerial in use is a 12-element array in the loft.

The set has been switched on when a test card was showing and left for about an hour, during which period there was no sign of vertical or line slip.—A. Soden (Upminster, Essex).

The fault appears to be due to a slight fault in the video amplifier circuit and therefore your attention should be directed to the PL83, associated components and the two diodes.

**PHILIPS 19TG158A**

Tuned to BBC the vertical hold locks the picture approximately midway on the control as one might expect. Tuned to ITV the picture fails to lock at all, even though the control is rotated through its full travel. The picture quality is very good on both channels.—B. Horne (Felixstowe, Suffolk).

Whilst the fault could well be in the sync separator circuit, check the valve and components; it may be necessary to check the video amplifier and the associated electrolytic capacitors.

**BUSH TV92**

Within five or ten minutes after being switched on the picture rolls and then breaks up. I have put in a new frame hold valve (PCL85) and a PL81.—J. Hope (Chester).

The fault could be caused by a faulty ECC83 valve. Check the sync separator components and components associated with the hold control. Check the video stage if necessary.

**BUSH TV62**

Could you tell me how to adjust the local oscillator on channels 1 and 9?—S. A. Nadel (London, S.W.16).

The oscillator adjustment on the TV62 is the fine tuner knob which is brought out to the front. A separate plastic knob is provided for BBC adjustment only, this protruding up at an angle from the top of the tuner.

**PYE V4**

I wish to convert to accept ITV channel 10. Could you give me some information on the following and any additional information you think would be helpful?

- (1) Type of turret tuner most suitable with i.f. required.
- (2) Details of conversion.
- (3) Valve of limiting resistor required if silicon power rectifier is fitted in place of the PY82s.—W. B. Jackson (Ayr).

The three most suitable tuners are the Pye 47 unit, the Brayhead 16S and the Cyldon P16H. The i.f.s are in the 16Mc/s band with local oscillator beating high. As most of the tuners are out of production we would not like to offer fitting instructions until we know which unit you have obtained.

**SOBELL ST196**

When the brightness increases, the tube blanks out. On decrease, the picture returns. I have changed V5 (PCL84) and V15 (DY86), with only temporary improvement.—E. G. Jackman (High Wycombe).

Low h.t. voltage could be aggravating this symptom. You say that "temporary" improvement is affected by the replacement of V5 and V15. Perhaps one or both of these replacement valves have deteriorated. Check this possibility and ensure that the mains voltage selector is set to suit your local mains supply voltage.

**EKCO TC267**

Can you please give me instructions for fitting a new c.r.t. to this set?—R. C. Westney (Preston, Lancashire).

To remove the c.r.t. first unplug and remove the chassis, unscrew the spot wobble panel, lay the cabinet face down on a soft surface, release the 4 x 2BA large nuts, one at each corner of the c.r.t. cradle, and with withdraw the entire cradle backwards by a series of angular movements. Remove tube and cradle from mask and glass, four screws, mark position of ion trap and scan coils, slacken clamping band around tube bowl and lift tube cradle and scan coils off c.r.t. Thoroughly clean all parts before replacing in reverse order.

## PYE V14

The picture is elongated and cannot be rectified by the vertical controls. Would you please let me know the components most likely to be the cause of the trouble?

I also get poor reception on channel 9, London ITV. Could this be improved by replacing V1 (PCC84) in the tuner with a 30L15?—W. Bailey Chelmsford, Essex).

The symptoms you describe suggest a weak line output valve type PL81 or low h.t. An improvement in ITA reception can sometimes be obtained by fitting a 30L15 but this usually involves making slight adjustments to the trimmers in the tuner.

## QUERIES COUPON

This coupon is available until MAY 19th, 1966, and must accompany all Queries sent in accordance with the notice on page 379.

PRACTICAL TELEVISION, MAY, 1966

### INVICTA 7069U

The picture is constantly expanding and contracting. Have changed the PCL85 and have had a slight improvement.—T. Harding (Southampton).

PCL85 bias capacitor 200 $\mu$ F 25V is faulty. Check the 0.02 $\mu$ F linearity capacitor.

# TEST CASE -42

Each month we provide an interesting case of television servicing to exercise your ingenuity. These are not trick questions, but are based on actual practical faults.

? A dual standard set gave perfect vision and sound on both BBC-1 and ITV programmes, yet on BBC-2 the picture was affected by a hum-ripple symptom, although the sound was reasonable. It was discovered that by slightly de-tuning the u.h.f. station selector the hum symptom was considerably worsened, to the extent of the top half of the picture almost blacking out.

The effect was rather symptomatic of modulation hum on the vision channel and with this in mind the u.h.f. tuner valves were checked by substitution, but to no avail. The output of the u.h.f. tuner was then short-circuited, and although—as would be expected—this cut off the BBC-2 reception, the vision ripple effect was present still on the raster.

The input then from the tuner to the vision detector was short-circuited, each stage in turn, and the symptom remained until the control grid of the video output valve was shorted. This latter action cleared the hum-ripple effect.

What was the most likely cause of this trouble, bearing in mind that the set used a common video amplifier stage for the two standards and the 405 line standard was completely unaffected?

The solution to this problem will be given in next month's issue of PRACTICAL TELEVISION, as also will another Test Case.

## SOLUTION TO TEST CASE 41

### Page 333 (last month)

There is no reason why two u.h.f. signal boosters cannot be connected in cascade (series) provided due consideration is given to the matching at the input to the first one, at the output of the second one and at the coupling between the two.

The trouble encountered by the enthusiast in Test Case 41 was almost certainly caused by in-

stability. That is, one or (more likely) both of the amplifiers going into a state of oscillation. The oscillatory signal so generated can beat with the tuners oscillator signal and give rise to beat-frequency effects that can be tuned in by the u.h.f. tuner, giving the effect rather like that of a short-wave receiver tuning over a host of unmodulated carriers.

The oscillatory frequency may not fall at exactly the same frequency as the Band IV or V TV programme, so some sort of reception may be possible in spite of the amplifier(s) oscillating. Nevertheless, an amplifier cannot work properly as an amplifier if it is oscillating.

When coupling two amplifiers it is best to arrange for this through a matching pad. One idea is to couple the amplifiers through a 6dB plug-in type attenuator, designed for u.h.f. applications. This gives a reduction in overall net gain, but it does go towards improved stability.

This trouble rarely arises, however, when cascaded amplifiers are coupled through relatively long lengths of coaxial feeder, such as if one amplifier is at the masthead and the other at the set. In this case, the impedance buffering effect of the cable facilitates the matching.

Nevertheless, there are times when neither the feeder at the aerial nor at the set is properly matched. Standing waves thus set up on the feeder and if a transistor booster is employed under this condition, the stability margin of the amplifier is impaired and instability is likely to result. As in Test Case 41, when only a single amplifier was used by the enthusiast.

Altering the length of the cables at the input and the output can improve the matching under these conditions and, as the enthusiast found, can restore stability and improve the overall signal/noise ratio.

**SETS & COMPONENTS**

**OLYMPIC II TV.** S.A.E. for itemised price list.  **AJAX ELECTRONICS,** 18a Rumbold Road, Fulham, S.W.6.

**STOP**

**FULLY GUARANTEED L.O.P.T. REWINDS**

**We can rewind ALL makes except Oil Filled or Fully Encased type**

A few of the types are listed below. **ALL AT 50/-**

PHILIPS 1768 to 17TG100 etc.  
STELLA 8617 to 1007 etc.  
Above types should be sent complete.  
PYE V4 to 700 etc.  
Also Frame Output Transformer Rewinds.  
S.A.E. Enquiries P. & P. 4/-, C.O.D. 6/-

**WITWORTH TRANSFORMERS Ltd.**  
26 All Saints Road, North Kensington  
W.11 Telephone: BAY 9071

**NEW MULLARD BY100!**

WITH 25 ohm Resistor ... 6/-!  
ALSO New EF80, PCF805, PC97,  
PCF801, etc. 5/-! NEW 12in. tubes 50/-!

**M/S E. JOHNSON**

12 PANK AVENUE, NEW  
BARNET, Herts. (Mail Only)

"HEATHKITS" can now be seen in London and purchased on H.P. Free brochure. **DIRECT TV REPLACEMENTS LTD.,** 126 Hamilton Road, West Norwood. S.E.27. GIPsy Hill 6:66.

**R. & R. RADIO & TV SERVICE**

44 MARKET STREET

BACUP, Lancs. Telephone: 465

6F13	4/6	PY32	6/-	30P12	5/-
6K25	10/-	6F15	5/-	6L18	4/6
6/30L2	5/-	6U4gt	5/-	98W6	5/-
EBF80	5/-	EB91	1/-	6F1	2/6
EF91	2/6	EBF89	5/-	EF80	1/6
ECC82	4/-	EF85	5/-	ECL80	4/-
20P3	5/-	EY86	4/-	30F5	6/-
30PL1	5/-	20P4	7/6	PL36	7/6
PCC84	4/-	PL38	6/-	PL82	4/-
PCL83	5/-	PCF80	4/-	PY83	5/-
PL83	4/-	PL81	5/-	U301	6/-
PZ30	5/-	PY81	3/6	10P13	5/6
10F1	1/-	U801	7/6	20F2	5/6
10P14	5/-	10LD11	5/-	20P5	6/6
20D1	2/-	20L1	5/-	30P4	7/6
30FL1	6/6	20P1	6/6	PY82	5/-

Post 6d. per valve. Three or more post free. Ex used Equip.

**New valves, 6K8, 6V6, 6R7 4/6, 6K7, 6F6, 6B8G 3/-.**

**Turret Tuners ex TV as removed, 8/-, post 2/9.**

**Line output transformers, scan coils, etc. State make and model No. with all enquiries.**

**Fireball Tuners, as removed 14/6. Post 2/9.**

**Ekco line output shrouds, 8/- incl. post.**

**Reclaimed Tubes, MW43/69, 43/80 AW43/80, 30/- carr. 10/- G.B. only.**

**RATES: 4/- per line or part thereof, average five words to line, minimum 2 lines. For No. 1/- extra. Advertisements must be prepaid and addressed to Advertisement Manager, "Practical Television", Tower House, Southampton Street, London W.C.2.**

**SETS & COMPONENTS (continued)**

**TELEVISION TUBE BARGAINS.** Brand new returned and fully tested, with guarantee card for 2 years. 12" 70s 75/-, 21" 90/- and 90" 80/-. 17" to 23" 110" 90/-. Please send o.d. tube with order. Sorry no C.O.D. Cash with order only. 10/- ins. and carriage. **ATLAS TELEVISION SERVICES (Bradford) LTD.,** 124 Barkerend Road, Bradford 3, Yorkshire.

**TUBES, AERIALS, VALVES**

U.H.F. aerials. Bands I, II & III aerials. U.H.T. transistorised boosters. I.T.V. boosters. Returned T.V. tubes. Valves, etc. New and second-hand T.V. sets. Transistor Radios and all types of Electrical Appliances. Quotations without obligation. Coaxial cable, fluorescent light fittings, all at special prices to the trade and Home Engineers. S.A.E. for list.

**G. A. STRANGE**

**BROADFIELD, NORTH WRANHALL,** nr. Chippenham, WILTS. Tel. Marshfield 236

**REBUILT TV TUBES.** 24 months guarantee, from £4. Free delivery London area. Return no mail order. **NG.T. ELECTRONICS LTD.,** SPR 3360

**TV SPARES**

**Fully Guaranteed Makers Parts Telephone orders sent same day Line Output Transformers**

Alba 324 etc., 47/6. Bush TV53, 79/6; TV80, 95/-. Ekco 221-311, 72/3; 330 etc., 79/3. Ferranti, 72/3-79/3. Murphy 270/280, 85/-; 310-350, 70/-; 410-540, 85/-; 659/759, 70/-. Pye VT 17 etc., 65/-.

Any other make or model supplied

Scan Coils from 55/-

Some used parts available

**EKCO-FERRANTI SHROUDS**

17/6 each, P. & P. 1/- each

Open all day Saturday

Terms: C.W.O. or C.O.D.

Post. & Packing 4/-

**BROCKLEY TV**

28 Brockley Cross : London, S.E.4 (T.C.S. M.O. DEPT.)

Telephone: TIDeway 5394

CALLERS WELCOME

**THIS MONTH'S SCOOP!**

New, Boxed and Tropicalised, in Beautiful Cabinets, 525-625 line

**EXPORT T.V. SETS**

19in. £33; 23in. £39

**TELEVISION TUBE SHOP**

48 Battersea Bridge Road, S.W.11

**TELEVISION TUBE SHOP**

The

**NEW TUBE Specialists**

AW36-20, 21	£5.12.6
AW36-80	£5. 7.6
AW43-80	£6. 7.6
AW43-88, 43-89	£6.12.6
AW47-90, 91	£7.10.0
AW53-80	£7.12.6
AW53-88, 53-89	£7.17.6
AW59-90, 59-91	£9.10.0
C148M, FM	£5.15.0
C178M, FM, HM	£6. 7.6
C17LM, PM, SM	£6.12.6
C21HM, SM, TM	£7.17.6
CME1402	£5.17.6
CME1702, 1703	£6.12.6
CME1705	£7. 7.0
CME1901, 1903	£7.10.0
CME2101	£8. 7.6
CRM93	£5.10.0
CRM124	£5.10.0
CRM141, 2, 3, 4	£5.17.6
CRM152	£5. 0.0
CRM153	£3.19.6
CRM171, 2, 3	£6. 7.6
CRM211, 212	£7.17.6
MW6-2	£6.17.6
MW22-16	£5. 2.6
MW31-16, 74	£5.12.6
MW36-24, 44	£5. 2.6
MW43-64, 69	£6. 7.6
MW43-80	£6. 7.6
MW53-20	£7.12.6
MW53-80	£7.12.6
14KP4A, 141K	£5.12.6
171K, 172K, 173K	£6. 7.6
6901A	£6.19.6
7201A, 7230A	£5.12.6
7204A	£5.10.0
7401A	£6. 7.6
7405A	£6.12.6

Manufacturers' Reprocessed Tubes available at £1 each less than the above prices.

All tubes tested before despatch and guaranteed for 12 months.

**CARRIAGE 10/-**, via B.R.S. or 15/- via passenger train. Add 2/6 for Comprehensive Insurance.

**TERMS £2 down** (plus carriage) balance £1 per month.

Midland Stockists;—

**Amateur Electronics Co.**  
240 Lichfield Road, Aston,  
Birmingham.

**TELEVISION TUBE SHOP**

48 BATTERSEA BRIDGE ROAD  
LONDON S.W.11. BAT 6859  
JUST SOUTH OF THE BRIDGE

OPEN SATURDAY UNTIL 4 p.m.



SETS & COMPONENTS (continued)

GENUINE BRAND NEW TUBES! 2 YEAR GUARANTEE (leading manfrs.)

Space precludes full list but representative range herewith. Large stocks, carriage 10/-.

TOP QUALITY, WHY BUY ORDINARY REBUILDS?

Table listing vacuum tube models and prices, including CRM.124, MW31/74, AW36/80, CME1402, etc.

ALSO 19" and 23" TWIN PANEL TUBES, £10 and £13.

Send for free full tube and valve list

Technical advice available.

Immediate despatch

PHILIP H. BEARMAN

6 POTTERS ROAD NEW BARNET, HERTS. Telephone: BAR 1934,7873

STOP PRESS!

30P19 11/-! Quantity discount

STOP PRESS!

PL81, PCF80 6/6!

TV SPARES, fully grtd. Makers' Parts. Telephone orders sent same day C.O.D. Line O.P. Trans Murphy V270/280 99/6, Ekco T311, 330, 221, 231, 327 series and Pye VT4 etc., all 62/6. Most types stocked. Send S.A.E. for quote. Add 4/- p.p. Ekco/ Ferr Plastic Hsgs 15/-. KING'S (ORPINGTON) LTD., 8 Cray Parade, Main Rd., St. Pauls Cray, Kent. Orpington 50566.

GUARANTEED ideal for any recorder.

TAPE World Famous make. PRICES SLASHED. APPROX. HALF PRICE!

By enormous purchase we can offer you fully tensilised Polyester/Mylar and P.V.C. tapes of identical Hi-Fi wide range recording characteristics as top grade tapes. Quality control manufacture. Not standard in any way. TRY ONE for YOURSELF. THEY ARE TRULY WORTH A FEW MORE COPPERS.

Table comparing tape specifications: STANDARD PLAY vs DOUBLE PLAY vs LONG PLAY vs TRIPLE PLAY vs QUADRUPEL PLAY.

Postage 1/- per reel. Post free and less 5% on three. Trade and quantity enquiries welcomed.

TECHNICAL TRADING CO.

All Mail Orders to Brighton Please. Devonian Court, Park Crescent Place, Brighton 680722, 67606 350/352 Fraxton Road, Portsmouth 22034 72 East Street, Southampton 25815

FOR SALE

HAMMERITE PATTERNS BRUSH PAINT FOR PANELS AND BOXES. THE PATTERN IS IN THE TIN. ALL YOU DO IS BRUSH IT ON! 2oz. tins 3/6, 1 pint 7/6, 1 gallon 35/-. 1 pint 15/- (\*sent by road). CARRIAGE: Orders up to 5/- 9d.; up to 10/- 1/9; over 10/- 2/9. Colours: Blue, Silver Black, or Bronze. Return of post service. Mon. to Fri. From your component shop or direct from the manufacturer: FINNIGAN SPECIALTY PAINTS (PT) Mickle Square, Stockfield, Northumberland Phone: Stockfield 2580.

VALVES & SERVICE SHEETS

TV AND RADIO, MOST MAKES Price 4/6 each, plus 6d. postage. VALVE Price List sent on receipt of stamped envelope. Valves guaranteed New and Boxed. Mail Order Only. TV ELECTRONICS Marketing House 361 Edgware Road, London, W.2.

VALVE CARTONS at keen prices. Send 1/- for sample and list. J. & A. BOXMAKERS, 75a Godwin Street, Bradford 10.

METAL RECTIFIERS

RECTIFIERS—CONTACT COOLED 14RA1283 (PC10) type 250 v. 250 mA 13/6. EC1 13/-; PC116, 7/6; 14RA1283 (PC3) see Silicon RECTIFIERS—FIN TYPES Equivs. for RM4 9/6; RM5 17/6; 14A989 18/6; 14A96 10/6; 14A97 11/6; EK2 15/-; EK6 15/-; 14A98 19/-; LW15 19/-; LW7 19/-; 14A100 19/-; FLW12 1A 5/-; 2A 7/-; 4A 10/6. SILICON TV 6/- or with instr. resistor-condenser, 7/6. MULTIMETERS from 32/-. Stamped envelope for full latest selection and bargain offers in cheap meters, Radios, Baby Alarms, Inter-coms and Walkie-Talkies. Under £1 P. & P. 6d, over £1 Post Free. NO C.O.D.

DURHAM SUPPLIES

175 DURHAM ROAD BRADFORD YORKSHIRE

WANTED

NEW VALVES WANTED . . . EY51, EY86, PL81, PCC84, PCF80, PCL82, PCL83, PY81, R19, 30P19, U25, etc. Best cash prices by return. DURHAM SUPPLIES, 175 Durham Road, Bradford 8, Yorks

SERVICE SHEETS purchased. HAMILTON RADIO, Western Road, St. Leonards, Sussex

DAMAGED AVO METERS WANTED. Models 7 and 8. Any condition. Any quantity. HUGGETTS LTD., 2-4 Pawson's Road, West Croydon

WANTED — Popular Brand New Valves.—R.H.S. Stamford House, 538 Great Horton Road, Bradford 7

WANTED—TV Cameras, any type. WESTON, 11 Fearnville Ave. Leeds 8 Tel. 656378.

MISCELLANEOUS

AERIALS

BBC2 Mast Fitting 10 Element 35/- BBC-TV 5 Element Plus Dipole 37/6 All brackets in stock. Co-ax Bd. and 1/4d. yard.

FLUORESCENT FITTINGS

4ft. Stove Enamelled 35/-. 5ft. 39/6 less tubes. Plenty of cut price tubes stocked 4-5 and 8ft.

H. CLAYTON (Elect. Dept.)

25-27 Oxford Rd., Windsor Tel. Windsor 62768

CONVERT ANY TV SET into an Oscilloscope. Instructions and diagrams 12/6. REDMOND, 42 Dean-close, Portlisle, Sussex.

How to use standard G.P.O. type telephones in a two way system with fully automatic ringing. May be used up to 5 miles apart, requires only standard twin lead from Auto-Unit. Easy to construct. Details and circuit 9/6 inc. post.

Build a low cost three to ten line fully automatic telephone system ideal to rent or sell to schools, factories, offices, etc. Use standard G.P.O. type telephones, full details, diagrams and instructions 18/6 inc. postage.

PARTRIDGE TECHNICAL PUBLICATIONS

Dept. V 21-25 Hart Road, Thundersley, Essex.

SERVICE SHEETS

SERVICE SHEETS (75,000) 4/- each. Callers welcome ALWAYS OPEN. 5 South Street, Oakenshaw, Bradford.

SERVICE SHEETS

4/- each, plus postage We have the largest supply of Service Sheets for all makes and types of Radios and Televisions, etc. in the country (speedy service). To obtain the Service Sheet you require, please complete the attached coupon:

Name: Address: fields for coupon completion.

To: S.P. DISTRIBUTORS

44 Old Bond St., London, W1.

Please supply Service Sheets for the following;

Make: Model No. Radio/TV fields for coupon completion.

I also require new 1966 List of Service Sheets at 1/6 plus postage. (please delete items not applicable)

I enclose remittance of (which includes postage)

MAIL ORDERS ONLY (May PT.)

**SERVICE SHEETS**  
(continued)

**SERVICE SHEETS.** Radio, TV, 5,000 models, List 1:- S.A.E. enquiries, TELRAY, 11 Maudland Bk., Preston.

**SERVICE SHEETS**

For all makes of Radio and Television—1925-1966. Prices from 1/-. Free fault-finding guide with all Service Sheets. Please send S.A.E. with enquiries. Catalogue of 6,000 models, 1/6.

All types of modern and obsolete valves. Radio and TV Books. S.A.E. lists, enquiries.

**HAMILTON RADIO**

Western Road, St. Leonards, Sussex.

**STATE MODEL No.** Radio 1/6, TV 3/-. S.A.E. DARWIN, 19 George St., St. Helens, Lancs.

**SITUATIONS VACANT**

**RADIO AND TV Exams.** and Courses by Britain's finest home-study School. Coaching for Brit.I.R.E. City and Guilds Amateur's Licence. R.T.E.B. P.M.G. Certificate, etc. Free brochure from British National Radio School, Russell Street, Reading.

**EDUCATIONAL**

**TV AND RADIO—A.M.I.E.R.E.** City and Guilds, R.T.E.B. Cert., etc., on "Satisfaction or Refund of Fee" terms. Thousands of passes. For details of exams, and home training courses (including practical apparatus) in all branches of Radio, TV and Electronics, write for 156-page handbook—FREE. B.I.E.T. (Dept. 172K), 29 Wright's Lane, London, W.8.

**A.M.I.Mech.E., A.M.I.E.R.E.** City and Guilds, G.C.E., etc. Become a Technician or Technician's for high pay and security. Thousands of passes. For details of exams and courses in all branches of Engineering, Building, Electronics, etc., write for 156-page handbook—FREE. B.I.E.T. (Dept. 171K), 29 Wright's Lane, London, W.6.

**TECHNICAL TRAINING**

**CITY AND GUILDS** (Electrical, etc.) on "Satisfaction or Refund of Fee" terms. Thousands of passes. For details of modern courses in all branches of Electrical Engineering, Electronics, Radio, TV Automation, etc., send for 156-page handbook—FREE. B.I.E.T. (Dept. 173K), 29 Wright's Lane, London, W.8.

**PADGETTS RADIO STORE**  
**OLD TOWN HALL,**  
**LIVERSEDEGE, YORKS.**

Telep. one: Cuckhoo 2868

18 Set Receiver, 1 Valve Battery S/II 6-9 mch., Clean condition, 1/2/6. Post 5/-.

68 Set Receiver, 4 Valve Short Wave Battery Set, New, 15/6. P/P 5/-.

300 Micro-Amp Meter from 18 Set Tx, 7/6. P/P 1/9.

New 500 Micro-Amp Meter from 68 Set Tx 12/6. P/P 1/9.

Multiflash Pattern Slow Motion Drives, Removed from units, 5/-, P/P 1/9. Magic Eye with Ladder, Ex Units Octal Base, 2/6. P/P 1/3.

New Boxed Tube Unit, CR100, Complete with Two small CRT Tubes VCRX293 and VCRX298, Plus 21 small valves and 0-1 ma. meter. Relays removed, 57/-, Carr. 10/-

Reclaimed Tubes, Six months' guarantee AW43/80, 30/-; MW43/80, 30/-; MW43/69, 30/-

CRM172, 30/-; CRM142, 17/-; 12" Tube, 10/-

17" Tubes, perfect but without guarantee, 17/- each. Carriage on any tube in G.B., 10/-

Specially Selected Nearly New Valves with 6 months' guarantee. Single valves Post 7d.

EF91	6/-	807	5/-	EF91	1/9
PCF84	5/6	ARP12	1/6	6K7	2/-
PCF80	5/6	ECL80	3/6	6K8	2/-
PL30	6/-	ECC83	5/-	6V6	2/9
PL81	5/6	ECC82	4/3		

**VALVE LIST**

Ex Equipment, 3 months' guarantee

Single Valves Post, 7d.

EF90	1/6	KT36	5/-	6F14	5/-
ECL30	1/6	PCF80	2/-	10C2	2/6
EF91	0d.	PCC84	2/-	10P13	5/6
EB91	9d.	PCL82	4/-	10P14	5/-
EPF80	3/-	PCL83	3/-	20L1	2/-
ECC81	3/-	PCL84	2/-	20L1	5/-
ECC82	3/-	PCL85	1/-	20P4	4/-
ECC83	4/-	P230	5/-	20P4	8/6
EL84	5/-	PY81	1/6	U91	8/6
EX51	2/6	PY82	1/6	U329	5/-
EP50	1/-	PL81	4/-	U31	5/-
EX86	5/-	PL36	5/-	U191	5/-
6K25	5/-	PY33	5/-	U281	5/-
6U4	5/-	6B8	1/6	U282	5/-
6P25	6/-	6B1	1/-	U25	5/-

Special Offer, Bush TV56 17" 13-channel TV Sets in good working order fitted with good tube. Cabinet condition fair. £8 Carriage 10/-

Untested 17" TV Sets complete fitted with all BBC and ITV coils, 50/-. Carriage, 10/- New Jap Earpieces complete with lead and plug, 8 ohms, 3 or 5mm., 1/11 or 20/- per doz. Post Free.

Diodes, Top grade, No duds, 3/- per doz Post Paid.

Perfect Speakers removed from TV Sets Round 8", 6/-; Rola 6 x 4, 3/-; Goodmans 7 x 4, 5/-; 6" Round, 3/-; Philips 5" Round, 3/-. Plus Post on any Speaker 2/9, 6" x 4" 6" and 5" Round Speakers, 6 for 20/-, Post Paid.

**Please mention**  
**"Practical Television"**  
**when replying to**  
**Advertisements**

**A SUCCESSFUL CAREER IN**  
**ELECTRONICS, RADIO AND T.V.**  
**CAN NOW BE YOURS AT VERY**  
**LITTLE COST!**

**NEW. No. 500 RADIO AND**  
**TELEVISION COURSE 75/-**

Here at last is your opportunity to own a most complete course at a very modest cost! This expanded course which now in miles-telephon as well as radio repair training could get you started on a whole new career!

The Radio Section of the course was ORIGINALLY DEVELOPED BY THE RADIO TECHNICAL INSTITUTE, where the television Section of the course has formed the basis of instruction provided by one of the world's largest television and electronics firms.

Compares lesson by lesson with some courses costing ten times as much! You save because you receive all the lessons at one time and are not required to purchase equipment you may not need.

The lessons are crystal clear, practical, easy to master and use. Early lessons make fundamentals clear even to the beginner, while other lessons will give you the practical know-how of an expert!

The new 500 Radio & Television Course consists of 352 large quarto size pages of instruction, hundreds of illustrations. We positively guarantee that you will be delighted or your money refunded!

**New. No. 600 RADIO-TELEVISION**  
**ELECTRONICS COURSE 85/-**

This is really big value in home training. Similar in details to the above course excepting that you get an extra 56 pages of instruction making a total of 408 quarto size pages. Hundreds of illustrations. Includes all the usual subjects plus Radio Transmitter Circuits, Electronic Test Equipment, Thyatron Tubes, Inter-Communicators, Sound Level Meters Servicing Printed Circuits and many more similar items. This course could be your first step into the fascinating world of electronics!

**No. 400. ELECTRONICS COURSE 45/-**

A complete home-study course of 35 lessons. Consists of 216 large quarto size pages of instruction. Comes complete with instructor's notes and test questions. This is a modern course that teaches without resorting to comic strip methods... Thousands of readers of this magazine have taken this course and enjoyed every minute of it... Why not you? Clip this coupon for your free trial offer now!

**UNCONDITIONALLY GUARANTEED TO**  
**GIVE COMPLETE SATISFACTION**

Any course not satisfactory may be returned within 10 days post-paid for full refund or credit of the purchase price.

**IF YOU SEND CASH WITH ORDER WE WILL INCLUDE A FREE BOOK** worth 4/6 to 5/- if bought separately. By sending cash you reduce book-keeping and other costs which we pass back to you. But you must include cash at the time of order to get this special offer.

**\*\*\*\*\* FREE TRIAL OFFER \*\*\*\*\***

**PAY ONLY 5/- per week if you wish.**

To: **SIM-TECH TECHNICAL BOOKS DEPT. F6,**  
Gater's Mill, West End, Southampton, Hants.

Please send the courses I have circled.

No. 500  No. 600  No. 400   
If not delighted I may return any book post-paid without further obligation on my part. Otherwise I will pay cash price of 5/- weekly (10/- fortnightly) commencing not later than 10 days after delivery. I am over 21 years of age. (If under 21 parents should place order.)

I enclose cash to the sum of £  
I understand you will refund this money if I am not 100% satisfied and I return the book within 10 days.

Please send me the free book(s) I have ticked.  
 Oscilloscope Book  Electronic Gadgets Book  
 Transistor Book  Radio Instrument Book

Name .....

Address .....

Just Published

**TRANSISTOR POCKET BOOK**

R. G. Hibberd, B.Sc., M.I.E.E., Sen.M.I.E.E.

A comprehensive guide to the characteristics and use of the various types of transistor now available. The manufacture of the various types of transistor, up to and including the latest epitaxial planar, field effect and metal-oxide silicon transistor, is described in detail in order to make clear the different characteristics of each. Includes notes on the use and handling of transistors, and chapters on solid state circuit techniques and recent developments.

7½" x 5", 312 pages, 220 line diagrams and photographs. 7 tables. 25s.

From your Bookseller, or in case of difficulty, 27s. from  
George Newnes Ltd., Southampton Street, W.C.2

**NEWNES**

# REBUILT TUBES!

You're safe when you buy from  
**RE-VIEW!**

- ★ Each tube is rebuilt with a completely new gun assembly and the correct voltage heater.
- ★ Each tube comes to you with a guarantee card covering it for a year against all but breakage.
- ★ Each tube is delivered free anywhere in the U.K. and insured on the journey.
- ★ Each tube is rebuilt with experience and know-how. We were amongst the very first to pioneer the technique of rebuilding television tubes.

## RE-VIEW ELECTRONIC TUBES

237 LONDON ROAD, WEST CROYDON,  
SURREY. Tel. THOrnton Heath 7735



**HERE IS WHAT YOU  
PAY:**

12in. ...	£4.15.0
14in. ...	£5. 0.0
15in. ...	£5. 5.0
17in. ...	£5. 5.0
19in. ...	£5.15.0
21in. ...	£7. 5.0

Cash or cheque with order, or cash on delivery

—Discount for Trade—

Old Tubes Purchased

## VALVES SAME DAY SERVICE NEW! TESTED! GUARANTEED!

SETS	1R5, 1R5, 1T4, 3R4, DAF91, DF91, DK91, DL92, DL94, Set of 4 for 16/-, DAF95, DF96, DK96, DL96, 4 for 24/6.
1A7GT	7/8 7/15
1H5GT	7/8 7/17
1N5GT	7/9 7/14
1L5	4/8 9BW6
1S4	4/8 10C2
1R5	3/8 10F1
1T4	2/8 12AT7
3A5	6/8 12AU6
3Q4	5/8 12AU7
3R4	4/8 12AX7
3Y4	5/8 12K7GT
5T4G	4/8 12K8GT
5Y3GT	4/11 12Q7GT
5Z4GT	6/8 20L1
630L2	8/8 20F3
6L5	2/- 20F4
6AM6	2/8 20P5
6AQ5	4/8 2514GT
6AT6	4/- 30C15
6AR6	4/8 30F5
6RE6	4/8 30FL1
6R6	5/8 30F15
6BW6	7/8 30L17
6P3	3/8 30P4
6P4	3/8 30P12
6P23	9/- 30P19
6K7C	1/8 30P14
6K8G	4/8 30P14R
6K8GT	7/8 30P14L
6P28	9/8 35L15T
6Q7E	6/- 35W4
6R17GT	4/8 35Z4T
6V6	3/8 35A2
6V6GT	5/8 6063
6X4	3/8 A231
6X5GT	6/8 B36
7H6	10/8 C133
7B7	7/8 C11
7J3	7/8 DA492
7K3	4/8 DAF91
7Y3	5/- DAF96
8B	6/8 DC930
8E4	4/8 DC932
8E5	3/8 DC934
8E6	2/8 DC936
8E7	6/- DC938
8E8	3/8 DC940
8E9	12/8 DC942
8F0	7/8 DC944
8F1	4/8 DC946
8F2	2/8 DC948
8F3	6/8 DC950
8F4	3/8 DC952
8F5	1/8 DC954
8F6	4/8 DC956
8F7	2/8 DC958
8F8	6/8 DC960
8F9	3/8 DC962
8F10	1/8 DC964
8F11	4/8 DC966
8F12	2/8 DC968
8F13	6/8 DC970
8F14	3/8 DC972
8F15	1/8 DC974
8F16	4/8 DC976
8F17	2/8 DC978
8F18	6/8 DC980
8F19	3/8 DC982
8F20	1/8 DC984
8F21	4/8 DC986
8F22	2/8 DC988
8F23	6/8 DC990
8F24	3/8 DC992
8F25	1/8 DC994
8F26	4/8 DC996
8F27	2/8 DC998
8F28	6/8 DC1000
8F29	3/8 DC1002
8F30	1/8 DC1004
8F31	4/8 DC1006
8F32	2/8 DC1008
8F33	6/8 DC1010
8F34	3/8 DC1012
8F35	1/8 DC1014
8F36	4/8 DC1016
8F37	2/8 DC1018
8F38	6/8 DC1020
8F39	3/8 DC1022
8F40	1/8 DC1024
8F41	4/8 DC1026
8F42	2/8 DC1028
8F43	6/8 DC1030
8F44	3/8 DC1032
8F45	1/8 DC1034
8F46	4/8 DC1036
8F47	2/8 DC1038
8F48	6/8 DC1040
8F49	3/8 DC1042
8F50	1/8 DC1044
8F51	4/8 DC1046
8F52	2/8 DC1048
8F53	6/8 DC1050
8F54	3/8 DC1052
8F55	1/8 DC1054
8F56	4/8 DC1056
8F57	2/8 DC1058
8F58	6/8 DC1060
8F59	3/8 DC1062
8F60	1/8 DC1064
8F61	4/8 DC1066
8F62	2/8 DC1068
8F63	6/8 DC1070
8F64	3/8 DC1072
8F65	1/8 DC1074
8F66	4/8 DC1076
8F67	2/8 DC1078
8F68	6/8 DC1080
8F69	3/8 DC1082
8F70	1/8 DC1084
8F71	4/8 DC1086
8F72	2/8 DC1088
8F73	6/8 DC1090
8F74	3/8 DC1092
8F75	1/8 DC1094
8F76	4/8 DC1096
8F77	2/8 DC1098
8F78	6/8 DC1100
8F79	3/8 DC1102
8F80	1/8 DC1104
8F81	4/8 DC1106
8F82	2/8 DC1108
8F83	6/8 DC1110
8F84	3/8 DC1112
8F85	1/8 DC1114
8F86	4/8 DC1116
8F87	2/8 DC1118
8F88	6/8 DC1120
8F89	3/8 DC1122
8F90	1/8 DC1124
8F91	4/8 DC1126
8F92	2/8 DC1128
8F93	6/8 DC1130
8F94	3/8 DC1132
8F95	1/8 DC1134
8F96	4/8 DC1136
8F97	2/8 DC1138
8F98	6/8 DC1140
8F99	3/8 DC1142
8F100	1/8 DC1144

## BBC2, TV, RADIO & TAPE REC. SPARES

UHF 625 BBC2. Modify your set to BBC2. 1955 to 1963 models covered. Manufacturers' tuners, IF panels, etc. Send for free lists. **SPECIAL OFFER.** Complete Pye Ekco UHF conversion kits—tuner, transistorised IF and T.B. panel, fittings, circuit, etc. New in manufacturers cartons. Normally 18 Gns. Our price £8.10.0, post 3/6. Can be used to convert all makes of receivers.

**TRANSISTORISED UHF TUNERS** new, £7.15.0, post 3/6. **TV SIGNAL BOOSTER UNITS.** Sens. gain all stations. **PYE LABGEAR** trans'd. BBC1/ITA or UHF Battery "plug in", 75/-, UHF Mains "plug in", 97/6, UHF Masthead 105/-. Post Free. **CRTS.** Rebuilt, new guns, fully guaranteed 12 months. Mullard, Mazda 14", 17" £4.5.0; 21" £6.10.0, 110 20" extra. Callers only. **LINE OUTPUT TRANSFS.** Popular types available, brand new exact replacements fully guar. A selection which can be supplied:—

PHILIPS 1768 etc., STELLA 8617 etc.	98/6	ALSO L.O.T.s Available for
EKCO 221 to 331 (U25) types	42/6	
FERRANTI 1001 to 1011 (U25 types)	42/6	Alba Philco
EKCO FERRANTI (U26/perspex types)	74/6	Cosmor P. Scott
FERGUSON 406 to 606 etc. 74/6; 306, 308	42/6	Decca Pilot
MARCONI VT157, 158, 160, 161 etc.	74/6	Dynatron
GEK 1252, 1746, 1748 ranges	45/-	Regentn.
KB Royal Star PVP, QVP20	87/6	Emerson

Other models ... 45/-  
 HMV 1840 to 1854, 68/-; 1865 to 1869 ... 42/6  
 1870, 1890, 1910, 1920, etc. ... 74/6  
 SOBELL TS17, 346, 48/6; other models ... 72/6  
**PYE, PAM, INVICTA**, all recent models... 68/6  
 \*Prices for earlier models on request.

Postage and Packing for above L.O.T.s 3/6. C.O.D. 2/6 extra. **SCAN COILS.** Frame or p frame osc. transf., width/linearity coils, sound o p transf., mains droppers, control knobs, dual vol., controls, line osc. transf., resistors, condensers, etc. **TUNER UNITS.** Fireball, Pye Miniature, incremental, turrets, channel coils, technical replacements service available. **TAPE REC CHANGER.** Drive Belts, Heads, Pinch Wheels, Idlers, Motors for most British (incl. WALTER) and Continental. **SALVAGED COMPONENTS.** Large selection for popular models, clean, serviceable condition, turrets, transformers, etc., ENQUIRIES invited, quotations given. C.O.D. despatch available.

## READERS RADIO

24 COLBERG PLACE, STAMFORD HILL, LONDON N.16. STA 4587 & 85 TORQUAY GARDENS REDBRIDGE, ILFORD ESSEX. CRE 7441  
 Postage on 1 valve kit, extra 10/- 2 valves of more, postage 6d, per valve extra. **Ans' Parcel Insured against Damage in Transit 6d, extra.**

## MANOR SUPPLIES

64 GOLDERS MANOR DRIVE, LONDON, N.W.11 (Callers: 589b, HIGH ROAD (nr. Granville Rd), N. Finchley N.12). Open all week inc. Sat., HIL 9118 (Day) SPE 4032 (Evg.).



# VALUABLE HANDBOOKS FOR PRACTICAL MEN

## BEGINNER'S GUIDE TO ELECTRIC WIRING

J. H. M. Sykes, Assoc. I.E.E.

Covers the complete design and layout of electrical installations likely to be needed especially on domestic premises. All recent advances in the field covered, including the ring circuit and off-peak storage heating systems. 180 pages. 81 diagrams. 15s.

## A BEGINNER'S GUIDE TO RADIO

Specially written for those who are taking up studies in radio transmission and reception for the first time. Written in non-technical language and abundantly illustrated, it covers every aspect and each new term as it occurs is clearly and fully explained. 27 lessons. 100 illustrations. 6th Edition. 8s. 6d.

## A BEGINNER'S GUIDE TO TELEVISION

Lessons for the student, enthusiast and teacher covering such subjects as persistence of vision and scanning; the cathode-ray tube and timebase; interlacing; the aerial; the TV camera; scanning system; colour and stereoscopic television, etc. Conversion of 405 to 625 line pictures is covered. 63 illustrations. 128 pages. 3rd Edition. 2nd Impression. 8s. 6d.

FROM YOUR BOOKSELLER or by post plus 1s. 6d. per copy postage, complete order form below:

----- ORDER HERE -----

Please send me the following books. I enclose £ : s. d.

- ..... BEGINNER'S GUIDE TO ELECTRIC WIRING  
 ..... BEGINNER'S GUIDE TO RADIO  
 ..... BEGINNER'S GUIDE TO TELEVISION

NAME .....

ADDRESS .....

Simply complete this form and post it with your remittance to  
 George Newnes Ltd., Tower House, Southampton Street, W.C.2.

P.T.565

**NEWNES**