

# Practical JULY 1962 1'9

# TELEVISION

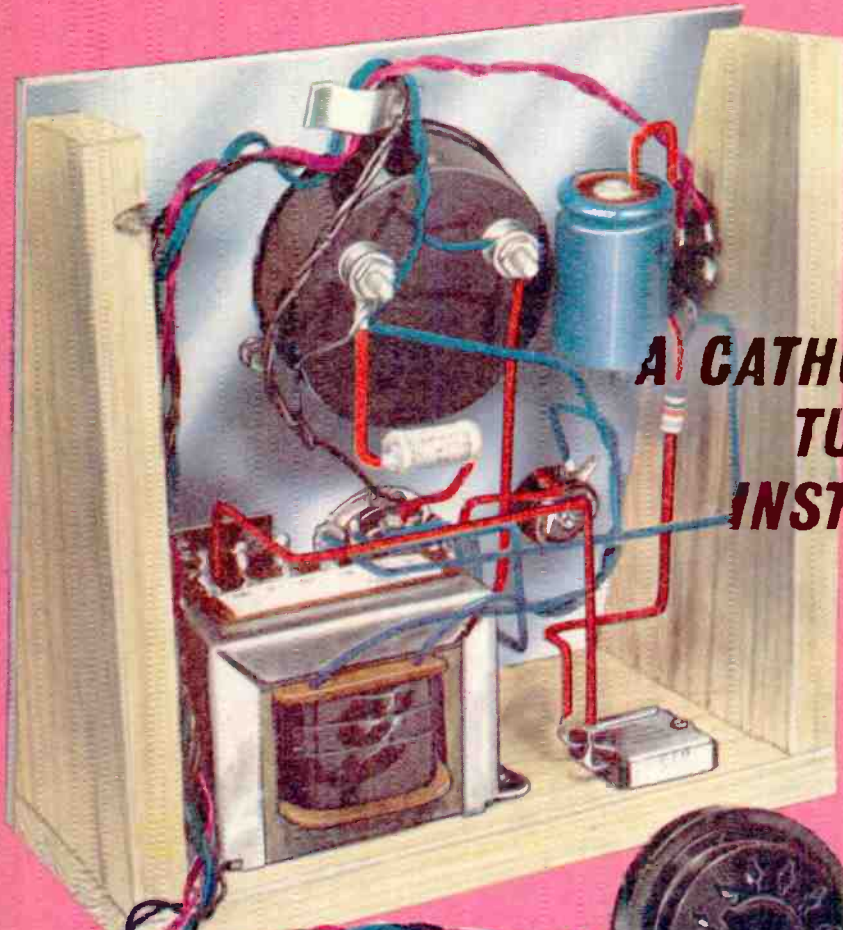

**A CATHODE RAY  
TUBE TEST  
INSTRUMENT**



**A PHOTOGRAPHIC  
METHOD FOR MAKING  
PRINTED CIRCUITS**



# Build your own Aerials...

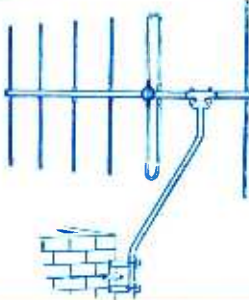

## AT HOME

**AERIAL FITTINGS FOR BAND III, BAND I & RADIO F/M.**  
Useful formulæ and hints for constructing your own aerial quickly and cheaply. Catalogue illustrating our increased range of Diecast Alloy Fittings, including Band III to Band I Mast Couplers, Reflector and Director Rod Holders, Insulators (both "Inline" and "H" types), Masthead Fittings, Masts and Elements, Chimney Brackets, etc. Send 1/- in stamps for the above, to:—

# Fringelevision Ltd.

**MARLBOROUGH, WILTS. Phone: 657/8**

All orders over £1 from January to August will be allowed a cash discount of 10%.

### RST

**MAIL ORDER DEPARTMENT**  
211 Streatham Road, Mitcham, Surrey  
**ALL VALVES LISTED ARE NEW STOCK**  
& Terms C.W.O. or C.O.D. Postage 3d. per valve.  
**MITCHAM 6202**

AZ1 15/-	EF92 4/-	PCF82 7/-	UY85 7/-	6K8G 7/6
B65 8/6	EL42 10/-	PCL82 9/6	VP4B 17/6	6K8GT 9/6
DAF91 7/6	EL84 6/9	PCL83 12/6	W142 8/6	6L1 13/-
DAF96 8/9	EL90 8/6	PENA1 17/6	W119 7/6	6L8G 7/6
DF91 4/-	EM80 8/6	PEN4A 17/6	W727 7/6	6L18 10/-
DH719 8/-	EY81 8/6	PEN4V 17/6	X78 21/-	6L19 17/6
DK91 8/-	EY84 10/-	PL36 15/-	X79 21/-	6N7G/GT 6/6
EABC80 6/-	EY86 8/6	PL81 12/-	Z21 12/6	6SL7GT 6/-
EAF42 9/6	EY91 4/-	PL82 8/-	Z27 4/-	6SN7GT 6/-
EB91 4/-	EZ35 6/-	PL83 10/6	Z152 5/-	6SV6G 5/6
EBF41 9/-	EZ40 7/-	PY80 7/6	Z719 5/-	6X5GT 8/6
EBF80 8/6	EZ41 7/-	PY81 7/6	1R3 7/6	7S7 10/-
EBF89 8/6	EZ80 7/-	PY82 7/6	5U4G 4/6	7Y4 7/6
EC91 9/6	EZ81 7/-	PY83 8/6	5V4G 9/6	8D3 4/-
ECC33 5/-	FC2 21/-	R10 10/-	5Y3GT 8/6	10LD11 15/-
ECC81 5/6	FC4 15/-	R19 19/-	5Z4G 10/-	12AH8 9/-
ECC83 7/6	FC13 21/-	TDD4 12/6	6A6GT 13/6	12AT6 7/6
ECC84 8/6	GZ32 10/6	TP22 15/-	6ALS 6/-	12AT7 5/-
ECC85 8/-	H30 5/-	U142 7/6	6AN5 7/6	12AU7 8/6
ECF80 8/6	H63 9/-	U147 7/6	6AQ5 6/6	12AX7 7/6
ECF82 8/6	HB90 9/6	U153 8/6	6BA6 6/-	12BA6 7/6
ECH42 9/6	HL92 8/6	UABC80 7/-	6BE6 6/-	12BE6 7/6
ECH81 8/-	HL133D 10/-	UAF42 8/6	6B06 6/-	12BH7 10/-
ECL80 9/6	KT33C 8/-	UBC41 8/6	6BR7 12/6	12J7G/GT 8/6
ECL82 9/6	KT66 15/-	UBF80 8/6	6BW6 7/6	12K7GT 5/-
EF37A 8/-	LZ319 12/6	UCH42 7/-	6BW7 5/-	12K8GT 10/-
EF40 15/-	MK46 17/6	UCH81 9/6	6BX5 5/-	12Q7 8/6
EF41 8/-	ML4 8/6	UCL83 8/-	6D2 4/-	12Q7GT 8/6
EF42 10/-	MSP4 17/6	UF41 7/6	6F1 10/6	12Q7 8/6
EF50(A) 4/-	MU14 9/-	UF93 8/6	6F12 4/-	12Q7GT 8/6
EF80 5/-	MX40 15/-	UL41 8/6	6F13 10/6	35Z4GT 6/6
EF85 5/-	N142 9/6	UL84 7/-	6F5G 4/6	50L6GT 7/6
EF86 10/6	N153 10/6	UY41 7/6	6J7GT 7/6	6K7GT 9/-
EF89 9/6	PCB4 9/6		6K7 2/-	
EF91 4/-	PCF80 9/6		6K7G 3/-	
			6K7GT 8/6	

**SEND FOR LISTS.**

Quotations given for any types not listed. Obsolete and old types a speciality.

## E.M.S. TELEVISION TUBES

**PROVED** with **Λ** reliability:-

**PACK A GREATER PUNCH THAN EVER**  
**TRY ONE NOW AND SEE THE DIFFERENCE!**

18 month guarantee with all our tubes

SIZE	PRICE	COST TO YOU WITH ALLOWANCE ON RECEIPT OF OLD TUBE
12in.	£4. 7.6	<b>£3. 17.6</b>
14in.	£4.15.0	<b>£4. 5.0</b>
15, 16, 17in.	£5.15.0	<b>£4. 15.0</b>

Carriage and Insurance 10'6 extra on all tubes

★ **BUY FROM ACTUAL MANUFACTURERS WHO KNOW HOW TO REBUILD A TUBE**

**MARSHALL'S for TELEVISION LTD.**

131 St. Ann's Road, Tottenham, London, N.15  
STAMFORD HILL 3267 & 5555

# REBUILT AND RESCREENED CATHODE RAY TUBES

Complete with all new components excepting glass

FOR QUALITY, RELIABILITY AND SERVICE BUY FROM BRITAIN'S  
LARGEST GROUP OF INDEPENDENT MANUFACTURERS OF REBUILT  
CATHODE RAY TUBES

**SUFFOLK TUBES LIMITED**  
1/3 UPPER RICHMOND ROAD  
PUTNEY, S.W.15.  
Tel: Vandyke 4304/5267

**MIDLAND TUBES LIMITED**  
37 GEORGE STREET  
MANCHESTER, 1.  
Tel: Central 4568/9

**VIDIO REPLACEMENTS LTD**  
25 ADDINGTON SQUARE  
CAMBERWELL, S.E.5  
Tel. Rodney 7550/7559

ALL TYPES  
12 MONTHS' GUARANTEE

KEEN PRICES

PROMPT DELIVERY  
WRITE FOR BROCHURÉ

**Winter Trading Co. Ltd.**  
95 Ladbrooke Grove  
London, W.11  
and Branches

**Weston Hart Ltd.**  
236/8 Fratton Road  
Portsmouth  
Tel: Portsmouth 24125

**Lawsons Ltd.**  
36 Cornhill  
Bury St. Edmunds, Suffolk  
Tel: Bury St. Edmunds 3304

**J. H. Sunderland**  
11 Clements Street  
Rochdale, Lancs.  
Tel: Rochdale 48484

**Wizard Productions**  
16 Withy Grove  
Manchester  
Tel: Dea 2772

**J. Charlesworth & Son**  
14 Hightown  
Crewe, Cheshire  
Tel: Crewe 2535

**Taylor's**  
162 Eastney Road  
Milton, Portsmouth  
Tel: Portsmouth 35000

**Millards Southern Rentals**  
3 High Street  
Aldershot, Hants.  
Tel: Aldershot 20408

**Lucketts of Banbury**  
57a/58a High Street  
Banbury, Oxon  
Tel: Banbury 2813

**H. Knowles**  
54/56 Chester Road  
Manchester  
Tel: BLA 9031

**Radio Services Ltd.**  
30 Mona Street  
Amlwch, Anglesey  
Tel: Amlwch 594

**Hi-Lite Ltd.**  
89 Southbourne Grove  
Southbourne, Bournemouth  
Tel: Bournemouth 44344

**R. Watson**  
Leathern Bottel  
Wavenden, Woburn Sands, Bucks  
Tel: Woburn Sands 2027

**R.E.S. Ltd.**  
17/19 Paynes Lane  
Coventry  
Tel: Coventry 28781

**J. Wildbore Ltd.**  
6-12 Peter Street  
Oldham  
Tel. Mai 4475

# RADIO BARGAINS

### SIGNAL GENERATOR



£7.5.0 or 30/- deposit and 6 monthly payments of 21/6. P. & P. 5/6 extra. Coverage 100 kc/s. 100 Mc/s on fundamentals and 100 Mc/s to 200 Mc/s on harmonics. Metal case 10 x 6 1/2 x 5 1/2 inch grey hammer finish. Incorporating three miniature valves and Metal Rectifier. A.C. Mains 200/250. Internal modulation of 400 c.p.s. to a depth of 30%; modulated or unmodulated R.F., output continuously variable. 500 millivolts. O.W. and mod. switch variable A.F. output. Incorporating magic-eye as output indicator. Accuracy plus or minus 2%.

**OSCILLOSCOPE FOR D.C. and A.C. APPLICATIONS**  
A high gain, extremely stable differential Y-amplifier (30 mV/C.M.). Provide ample sensitivity with A.C. or D.C. inputs. Especially suitable for measurements of transistor operating conditions where maintenance of D.C. level is of paramount importance. Push-pull X amplifier; Flyback suppression; Internal Time-base Scan Waveform available for external use; pulse output available for checking TV line O/P Transformers, etc. Provision for external I-P and C.R.T. Brightness Modulation. A.C. mains 200/250V. £18.18.0. P. & P. 3/- or £4.13.0 deposit, plus P. & P. 3/- and 12 monthly payments of 23/6. Full 12 Months' Guarantee including Valves and Tube.



### ALIGNMENT ANALYSER

A.C. mains 200/250 v. Provides: "Wobulator" (Swept Frequency) Operation, for FM/TV alignment linear frequency sweep up to 12 Mc/s. From 40 kc/s - 30 Mc/s. Capacitance Measurement. Two ranges provided. 0-60pF and 0-12pF. Special Facility enables true resonant frequency of any tuned ckt. I.F. transformer, etc., to be rapidly determined. Cash price £25.0.0, plus 5/6 P. & P. H.P. terms 30/- deposit, plus 5/6 P. & P. and six monthly payments of 21/6.

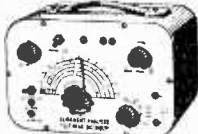

### CHANNEL TUNER

Will tune to all Band I and Band III stations. BRAND NEW by famous manufacturer. Complete with P.C.C. 84 and P.C.F. 80 valves (in series). I.F. 16-19 or 33-38. Also can be modified as an aerial converter (instructions supplied). Complete with knobs. 32/6 plus 4/6 P. & P.

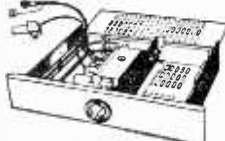

### HEATER TRANSFORMER

To suit the above, 200-250 v., 6/-, plus 2/- P. & P.

### LINE E.H.T. TRANSFORMERS

With built-in line and width control. 14kV. Scan coil, 50in. deflection on ferrite yokes. Frame O.P. transformer pl. 18 kv smoothing condenser. Can be used for 14in., 17in. or 21in. tubes. Complete with circuit diagram.

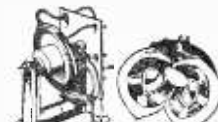

29/6 Plus 4/6 P. & P.

Focus Magnet suitable for the above (state tube). 10/- plus 3/- P. & P.

### CHANNEL TUNER

I.F. 16-19 Mc/s continuously tunable from 174-216 Mc/s. Valves required, P.C.C. 80 and P.C.C. 84 (in series). Covers B.C.F. and I.T.A. ranges, also Police, Fire and Tax's, etc.

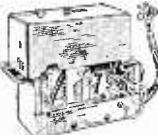

Brand new by famous manufacturer

10/- plus 3/- P. & P.

**RADIO & T.V. COMPONENTS (Acton) LTD.**  
23c HIGH STREET, ACTON, LONDON, W.3  
All enquiries S.A.E. Goods Not Despatched Outside U.K.

# BENTLEY ACOUSTIC CORP. LTD.

38 CHALCOT ROAD, CHALK FARM, LONDON, N.W.1  
Telephone PRImrose 9090.  
Express postal service. All orders despatched same day as received. Immediate despatch of C.O.D. orders if telephoned before 3.30 p.m.

0A2 17/8	71I7 8/-	E180F 34/8	E240 7/-	U282 23/8
0B2 17/8	787 9/8	E40 8/-	E241 7/-	U301 23/10
0Z4 6/-	777 8/8	E476 9/8	E280 7/-	U329 14/-
1A5 6/6	747 6/6	E4C30 9/-	E281 7/-	U358 17/-
147GT 12/-	98W6 11/-	E4F42 9/-	GZ30 9/-	U404 8/8
1C5 12/6	10C1 13/-	E434 2/8	GZ32 10/-	U801 23/10
1D6 10/6	10C2 7/2	E44 2/8	GZ34 14/-	U4020 19/1
1G6 17/8	10F1 27/2	E891 4/-	HN309 25/8	U4BC80 9/-
1H5GT 10/8	10L11 16/4	E8C3 23/10	HV82 20/-	U4F42 9/8
1L4 8/6	10P13 15/-	E8C33 5/-	K1T33C 10/-	U841 12/-
1LD5 5/-	10P14 19/8	E8C41 5/8	K1T36 30/7	U8C41 8/8
1LN5 5/-	12A0C 16/8	E8C81 3/-	K1T41 23/10	U8C81 11/8
1N5GT 10/8	12A06 17/8	E8F80 9/-	K1T44 12/8	U8F80 9/-
1R5 8/6	12A08 14/8	E8F83 14/4	K1T61 12/8	U8F89 6/8
1R4 8/-	12A17 8/-	E8F89 9/8	K1T63 7/-	U8C84 15/-
1R5 6/-	12A18 12/6	E8F82 8/8	K1T66 15/-	U8C85 9/-
1T4 3/8	12A27 7/8	E8C54 6/-	K1T88 43/8	U8F80 17/-
1U5 8/6	12A27 8/-	E8C57 8/8	K1T91 6/8	U8C42 9/8
3A4 8/-	12A27 8/8	E8C52 10/8	K1T93 7/8	U8C81 9/8
3A5 10/8	12A7 7/8	E8C92 17/8	K1T93 7/8	U8C82 11/8
3B7 12/8	12BA6 8/-	E8C34 25/8	K1T263 7/8	U8C83 19/8
3D6 5/-	12B6 8/-	E8C35 8/8	L63 6/-	U8F41 9/-
3Q4 7/8	12K5 18/8	E8C40 23/10	MHLD16 12/8	U8F42 12/8
3Q5GT 9/8	15A45 10/8	E8C31 8/-	MU121 8/-	U8F48 10/8
3R8 7/8	15A 10/4	E8C84 7/8	N87 23/10	U8F85 9/-
3V4 7/8	20D1 18/8	E8C83 7/8	N87 23/8	U8F86 17/8
5R4GY 17/8	20F2 27/2	E8C84 9/-	N108 23/10	U8F89 9/-
5U4G 8/8	20L1 27/2	E8C85 8/8	N98 21/8	U8L1 10/8
5V4G 10/8	20P 27/2	E8C86 13/8	N839 15/-	U8L4 27/8
6A5 10/8	20P3 23/10	E8F80 14/8	N939 17/8	U8L46 14/8
6Z3 120/5	20P4 27/2	E8C82 10/8	PC084 8/8	U8L84 8/8
5Z4G 9/-	20P5 23/10	E8C86 20/8	PC085 9/8	U8L84 8/8
6A7 10/8	25Z4G 9/8	E8C82 13/10	PC088 15/-	U8M4 17/8
6A8 9/-	27B1 20/8	E8C83 8/8	PC089 9/-	U8M4 17/8
6A9T 4/8	27B2 20/8	E8C84 8/8	PC090 9/8	U8M4 17/8
6AG5 5/8	30C1 8/-	E8C81 9/-	PCF82 10/8	U8Y21 17/1
6AG7 7/8	30F5 6/-	E8C83 14/4	PCF84 17/-	U8Y41 7/8
6AK5 8/-	30FL1 10/-	E8C80 9/-	PCF86 15/-	U8Y85 7/-
6AL5 4/8	30L1 8/-	E8C82 10/8	PCL22 10/-	U8V83 23/10
6AM6 4/8	30L5 18/8	E8C83 10/8	PCL23 10/-	V8C83 8/8
6AP5 7/8	30P 15/-	E8C86 17/8	PCL84 9/8	VR105 8/8
6AT6 7/-	30P12 7/8	E8F 23/10	PCL85 12/8	VR150 7/8
6AU6 10/8	30P14 10/8	E8F2 14/10	PCL86 12/8	W78 5/8
6BA6 7/8	30PL13 12/8	E8F3 4/-	PEN4A 17/8	W107 19/1
6B26 6/-	32LAGT 10/-	E8F7A 8/-	P8N 23/10	W229 20/8
6B46 8/-	35W4 7/8	E8F9 5/8	P8N46 7/8	X66 12/8
6BJ6 6/-	35Z4GT 9/-	E8F40 15/-	PL33 19/8	X78 23/10
6BQ7A 15/-	35Z5GT 9/-	E8F41 9/-	PL36 15/8	X79 23/10
6BR7 12/8	50C5 10/-	E8F42 10/8	PL38 27/2	X109 17/8
6BR8 19/11	50LGT 10/-	E8F43 7/8	PL81 10/8	Z66 7/8
6BR9 8/8	58AGT 10/-	E8F50(E) 8/-	PL82 7/8	Z66 17/8
6BW7 6/-	90AV 67/8	E8F54 5/-	PL83 9/-	Z77 4/8
6C4 5/-	90A6 67/8	E8F73 10/8	PL84 13/-	Transistors and diodes
6C5 6/8	90C1 18/-	E8F80 6/-	PM34 17/8	
6C8 8/8	90C9 37/8	E8F85 6/-	PX4 10/8	OA70 8/-
6C9 12/8	90C9 19/8	E8F86 10/8	PY32 12/8	OA73 3/-
6C10 9/8	150B2 18/-	E8F89 9/-	PY80 7/8	OA79 3/-
6C16 9/-	807 7/8	80A91 4/8	PY81 8/8	O81 3/-
6F1 27/2	4033L 12/8	E8F92 4/8	PY82 7/8	O81 3/-
6F6G 7/-	5783 7/8	E8F97 18/7	PY83 8/8	O86 4/8
6F8 13/8	745 18/8	E8F98 10/8	PY84 8/8	O86 4/8
6P23 10/8	AZ1 10/4	E8F183 19/1	PZ30 20/5	OA85 3/8
6P24 12/8	AZ1 14/4	E8F184 12/8	R12 9/-	OA210 11/-
6F33 7/8	B36 15/8	EK32 8/8	R18 14/-	OA211 20/-
6J5 8/8	OL33 19/8	E8L32 5/8	R19 20/5	OC19 48/-
6J6 8/8	CV1 19/11	E8L33 12/8	R241 8/8	OC22 23/-
6J7G 8/-	CY31 11/-	E8L34 15/-	SF42 12/8	OC23 87/-
6J7GT 10/8	DAC32 10/8	E8L38 27/2	SP61 3/8	OC26 25/-
6K7G 5/-	DAP91 6/8	E8L41 9/-	8U25 27/2	OC28 25/-
6K7GT 8/-	DAF96 8/8	E8L42 10/8	T41 9/-	OC29 46/-
6K8GT 10/8	DD41 14/4	E8L43 17/-	TY8E 18/7	OC35 25/8
6K9 8/8	D83 10/8	E8L43 20/5	U1214 8/8	OC44 11/-
6K25 20/5	D6F8 15/8	E8L34 7/8	U16 10/-	OC45 10/-
6L1 23/10	DF91 3/8	E8L35 14/4	U19 48/8	OC85 23/8
6L6G 8/8	DF98 8/8	E8L36 17/8	U22 8/-	OC86 25/-
6L7GT 7/8	DF97 8/8	E8L91 5/8	U24 30/7	OC70 6/8
6L7L 13/8	E8F83 8/8	E8L38 18/8	U25 10/8	OC71 8/8
6LL20 18/4	DK32 12/-	E8L820 19/1	U26 10/-	OC72 8/8
6P28 27/2	DK91 6/8	E8L21 27/2	U31 9/8	OC73 18/-
6Q7G 6/8	DK93 9/-	E8L22 19/8	U33 27/2	OC75 8/8
6Q7GT 11/-	DK96 8/8	E8M34 9/8	U35 27/2	OC77 18/-
6R9 6/8	CV1 9/11	E8L3 23/10	U37 8/8	OC78 8/8
6U5G 7/8	DLAG 12/8	E8M80 9/-	U45 13/8	OC81 3/8
6V6G 7/-	DL88 15/-	E8M81 9/8	U50 8/8	OC139 24/-
6V6GTG 8/8	DL72 15/-	EM84 10/8	U52 6/8	OC170 18/8
6X4 5/-	DL92 7/-	EM85 17/8	U54 20/8	OC171 14/8
6X5GT 6/-	DL93 8/8	E8Y1 8/8	U56 12/8	OC201 56/-
6J30L 10/-	DL96 8/8	E8Y1 9/-	U191 17/-	OC201 56/-
7B7 8/8	DM70 7/8	EY83 17/-	U201 17/-	OC203 24/-
7C5 8/-	E80F 30/-	EY84 14/-	U201 14/-	OCY71 29/8
7C8 8/-	E83F 30/-	EY86 9/-	U281 20/5	VC/R2 9/8

**METAL RECTIFIERS.** DRM1B 13/-. DRM2B and DRM3B 15/6. 1LW7 21/-. RMO 7/11. RM1 5/8. RM2 7/6. RM3 7/8. RM4 14/-. RM5 19/6. [1A] 86 17/8. 1A] 97 25/-. 1A] 100 27/- . 1A] 124 28/- . 1A] 130 28/- . 1A] 130 26 1/2 . 1A] 261 11/8. FC101 17/6. 16KRL 16.1 8/6. FC31 21/- . 10L3 22.2 1/10 . 16BE 23.8 1/8 . 18A 11.8 1/1 8/8 . 18R.1 22. 15/- . FC112 15/- . FC115 15/- . 1W 18 24/- .  
**ELECTROLYTICS.** Can types: 32 x 450 v. 1/8. 160 x 630/50 v. 7/- . 164 x 120/3 450 v. 8/8 . 60 x 250/275 v. 8/8 . 100 x 400/275 v. 12/8 . 100/275 v. 3/- . 200/275 v. 4/- . 100 x 200/275 v. 9/6. Tubular types: 840 v. 1/8 . 110/450 v. 2/8 . 132/450 v. 3/8 . 8 x 840 v. 3/8 . 10 x 1450 v. 4/8 . 32 x 3250 v. 4/8 . 8 x 16450 v. 3/8. Post/packing charge 6d. Post/ins except when stated. Post/ins except when stated 8d post free. C.O.D. 2/6 extra. Shop hours 8.30-5.30. Sat. 1 p.m. Any parcel insured against damage in transit for only 6d. extra.

Please note that all goods as certified are brand new. We do not sell second-hand goods or manufacturers' rejects. Our full list, with terms of business, includes all types of components, transistors, condensers, transformers, etc. Price 6d. subject to the full manufacturers' guarantees, and actually in stock. We do not sell second-hand goods or manufacturers' rejects.



**TRANSISTOR POCKET RADIOS**

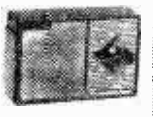

The "SAN-REMO" 5 Star is so tuned that it brings the voices of star entertainers and vocalists dramatically to life—in your home, office, etc., etc. . . . only 4 1/2" x 2 1/4" x 1 1/4". Fits easily into your pocket or handbag. Works for months off 8d. battery. Should last a lifetime, anyone can assemble it in an hour or two with our easy plan. Complete set of parts including miniature speaker, everything only 29/6. + 2/6. p. & p. C.O.D. 2/6d. extra. (Parts can be bought separately.) Limited period—so rush your order before it's too late—DEMONSTRATIONS DAILY.

**Only 29/6  
NO MORE TO PAY**

easy plan. Complete set of parts including miniature speaker, everything only 29/6. + 2/6. p. & p. C.O.D. 2/6d. extra. (Parts can be bought separately.) Limited period—so rush your order before it's too late—DEMONSTRATIONS DAILY.

**CONCORD ELECTRONICS**  
(Dept. B13/6) 210 Church Road, Hove SUSSEX

**RES/CAP. BRIDGE**

**38/-**  
p. & p. 2/6

Checks all types of resistors, condensers 6 RANGES

Built in 1 hour. Direct reading

**READY CALIBRATED**

Stamp for details of this and other kits.

**RADIO MAIL** (Dept. ZV)

Raleigh Mews, Raleigh Street, Nottingham

**Better, Brighter Picture Tubes**

**BRAND NEW THROUGHOUT—excepting glass**

12in. ... .. £4.10.0      14in. ... .. £5. 5.0  
15-17in. ... .. £5.15.0      21in. ... .. £7.15.0

New Silver Screen and Aluminising. All makes Mullard, Mazda, Emiscope, Cossor, Brimar, Emitron, etc.

**REBUILT MULLARD AND MAZDA TUBES**

12in. ... .. £3. 0.0      14in. ... .. £4. 0.0  
15-17in. ... .. £4.10.0      21in. ... .. £6.10.0

All Tubes Fully GUARANTEED 12 MONTHS. Dispatch same day. Cash with Order. Carriage and Insurance 10/-.

**S.T.S. Ltd.**

**35 POUND STREET, CARSHALTON, SURREY**

Telephone: WALLINGTON 9665

**ANNOUNCING A  
NEW TECHNICAL  
BOOK CLUB**

for  
**Practical Television Readers**

From now on, many of the best books ever written about television, radio and electronics will be available to Sim-Tech Club members on no interest free trial, easy payment terms. Members may cancel at any time and there is absolutely no obligation to buy anything! **SELECT UP TO THREE BOOKS FROM THE LIST, or simply SEND IN THE COUPON AND LEAVE THE CHOICE TO OUR EXPERTS! ONE BOOK WILL BE SENT EACH MONTH UNLESS CANCELLED.**

**SPECIAL BOOK CLUB PURCHASE**

**FUNDAMENTALS OF RADIO & ELECTRONICS**

(Book No. 99)  
Exceptional value, hard bound 895 page volume you will always treasure and use for constant reference. Recommended for engineer and amateur alike. Covers Mathematics of Radio and Electronics, Direct current circuits, valve and transistor principles, power supplies, transmission and recording of sound, audio and video amplifiers, frequency modulation, monochrome and colour television. Instruments, Radio antennas, radar, industrial electronics. Highly recommended. Previous editions have already sold over a quarter million copies. Price 57/6.

**NEW RELEASES FROM WIRELESS WORLD**

- (See liftie advertisements in Wireless World, for more details.)  
No. 100W. SQUARE-LOOP FERRITE CIRCUITRY. STORAGE & LOGIC TECHNIQUES. 42/- net.  
No. 101W. TELEVISION ENGINEERING PRINCIPLES & PRACTICE VOLUME 4. GENERAL CIRCUIT TECHNIQUES. S. W. Amos & Birkinshaw. Price 35/- net.  
No. 102W. TELEVISION RECEIVER SERVICING. RECEIVER AND POWER SUPPLY CIRCUITS. E. Spreadbury. M. Brit. I.R.E.E. 35/- net.  
No. 103W. ELEMENTS OF ELECTRONIC CIRCUITS. (BUILDING BRICKS FOR CIRCUIT DESIGN). J. M. Peters. A.M.I.E.E. 21/- net.  
No. 104W. HIGH QUALITY SOUND PRODUCTION AND REPRODUCTION. H. Burrell Hadden. (A BBC Training Manual). 42/- net.

**NEW COYNE JOB TRAINING BOOKS**

No. 4. LATEST INSTRUMENTS FOR SERVICING RADIO AND TELEVISION.  
This up-to-the-minute book tells all about modern radio, TV and electrical testing equipment and how to use it. Money-making short cuts on trouble-shooting, servicing, construction, and other jobs. Over 350 pages, 220 photos and diagrams. All data has been pre-tested in the Coyne radio shops. Washable Vinyl cloth covers. 26/-.

**No. 1. SPECIAL OFFER COYNE ELEMENTARY PRACTICAL RADIO-TELEVISION SET OF THREE VOLUMES total 1,038 pages, sturdy Vinyl washable covers. £3 12s. 6d. the set!**

These three volumes present the principles of construction, operation and testing of radio and television equipment in a SIMPLE, EASY TO FOLLOW manner.

One very important way in which these books differ from many other radio and television books is that the publishers did not try to assume the "extent of technical knowledge" of the reader. Every subject is explained COMPLETELY—while at the same time keeping it brief and to the point.

You will find hundreds of photos, charts, diagrams, etc., in these books. These have been provided to make it easier to understand the explanations.

**No. 6. COYNE TELEVISION SERVICING CYCLOPEDIA.**

Harold P. Manly.  
Quick and concise answers to TV problems in alphabetical order, cross indexed, fully illustrated, covers hundreds of questions involving radio TV, electronics operation and repair. 450 Illustrations; photos, diagrams, charts, test patterns, etc., 860 pages. Vinyl washable cloth covers. Price 47/6.

**No. 5. PRACTICAL TELEVISION SERVICING AND TROUBLE SHOOTING MANUAL.**

A book of fast time saving methods for servicing TV receivers. Includes dozens of new testing ideas all of which have been proven on the job. Contents include TV Servicing methods, TV Servicing Instruments, Tuners, Video I.F., Amplifiers, alignment, etc., with 200 crystal clear photos and diagrams. 437 pages. Vinyl washable cloth covers. Price 34/-.

**No. 9. PIN POINT TRANSISTOR TROUBLES IN 12 MINUTES.**

Trouble-shoot every type of circuit in ALL transistorized equipment! 625 pages; hundreds of illustrations; 120 check charts. 47/6.

**No. 19. REFRIGERATION MANUAL.**

Learn Refrigeration! This manual is a course in itself. Packed solid with information to enable you to do that repair job yourself. Used by many leading refrigeration firms as a standard reference. Features 364 pages together with 157 illustrations bound in cloth. An excellent buy at only 24/- plus postage.

**No. 8. PIN POINT TV TROUBLES IN 10 MINUTES.** Your most useful of-the-job! "Pin Point" Quickly and easily pin-points the exact trouble in any TV set. Covers 70 symptoms, 700 trouble spots. Over 340 cross-indexed pages; 50 time-saving Check-charts; 290 diagrams and photos; explanation of circuits and designs. 31/6.

**FREE TRIAL COUPON**

To Sim-Tech Technical Books, West End, Southampton. Hants. DEP1. PTVE3.

- Please enroll me in the new book club. I am interested in reviewing books on the following subjects.  
TV:  Radio;  Electronics;  Mathematics;  Transistors.  If I do not wish to purchase the book sent to me I may return it post-paid, within 10 days, send full cash, or pay only 1/- per week without interest charges.  
 I am a Beginner.  Amateur.  Engineer.  To start, I would like to see the following books (Insert number here) listed in this advertisement. (One at a time) Nos. ( ) ( ) ( ) ( ). (To see all books at one time please enclose one third total purchase price.) Amount enclosed £ ; s. d.  
 Tick here if enclosing full purchase price. (WE PAY POSTAGE). Same money back guarantee if not satisfied. Amount enclosed £ ; s. d. Postage charges. Orders under £3 allow 1/6d. Over £3 allow 2/- extra.

NAME \_\_\_\_\_

ADDRESS \_\_\_\_\_



# Practical Television

AND TELEVISION TIMES

VOL. 12, No. 142, JULY, 1962

Editorial and Advertisement  
Offices:

**PRACTICAL TELEVISION**

George Newnes Ltd., Tower House  
Southampton Street, W.C.2.

© George Newnes Ltd., 1962

Phone: Temple Bar 4363.

Telegrams: Newnes, Rand, London.

Registered at the G.P.O. for trans-  
mission by Canadian Magazine Post.

**SUBSCRIPTION RATES**  
including postage for one year

Inland - - - - £1.5.0 per annum  
Abroad - - - - £1.3.6 per annum  
Canada - - - - £1.2.0 per annum

## Contents

	Page
Editorial ... ..	461
Making Printed Circuits ... ..	462
NTSC Colour System ... ..	464
Curing Instability ... ..	467
Telenews ... ..	469
Servicing TV Receivers ... ..	471
Servicing Data and Modifi- cations ... ..	477
A CRT Test Instrument ... ..	480
Signal and Feeder Problems ... ..	484
How TV Remote Control Works ... ..	487
Underneath the Dipole ... ..	491
Letters to the Editor ... ..	495
Your Problems Solved... ..	496

The Editor will be pleased to consider articles of a practical nature suitable for publication in "Practical Television". Such articles should be written on one side of the paper only, and should contain the name and address of the sender. Whilst the Editor does not hold himself responsible for the manuscripts, every effort will be made to return them if a stamped and addressed envelope is enclosed. All correspondence intended for the Editor should be addressed to: The Editor, "Practical Television", George Newnes, Ltd., Tower House, Southampton Street, London, W.C.2.

Owing to the rapid progress in the design of radio and television apparatus and to our efforts to keep our readers in touch with the latest developments, we give no warranty that apparatus described in our columns is not the subject of letters patent.

Copyright in all drawings, photographs and articles published in "Practical Television" is specifically reserved throughout the countries signatory to the Berne Convention and the U.S.A. Reproductions or imitations of any of these are therefore expressly forbidden.

## More TV Stations

WE have often mentioned in our pages that the development of television in this country is now virtually halted and, neglecting the content of the programmes, it only remains to increase the coverage of the present transmissions to bring isolated areas within range of transmitters. In order to enable those living in fringe areas to receive TV programmes, we have published several aerial pre-amplifiers so that the available signal could be used to the best advantage—these units are operating with very good results in many areas.

Recently, however, it was announced that the third stage of the BBC's scheme to improve television and sound broadcasting in Britain has been approved. The 23 new television transmitters provided in this part of the plan will bring programmes to 40,000 viewers and give improved signals to a further 850,000. Thus, the pre-amplifiers used in many areas will no longer be necessary.

The new stations will be of the satellite type and work unattended. They will be of low power and receive signals from another transmitter, 'translating' them and radiating them on another channel. Naturally, the sites of the new transmitters will be chosen so that a suitable signal from the 'parent' station can be received.

The first and second stages of the BBC plan provide for 27 extra television stations which will increase the BBC's coverage to reach about 99.4% of the population. The third stage mentioned above will increase this percentage still further, but the stations in the third stage will in general be smaller and cheaper than those in the first two stages.

## EUROVISION

Since the Eurovision network was first developed, the number of programmes handled has increased from about one hundred per year at first—about eight years ago—to more than five hundred per year. As would be expected, the most popular programmes are those in which the differences of languages are of little importance, and variety, dramatic, and religious programmes were the least often accepted when available. Sport has always proved popular, football especially, since it is rapidly gaining in favour on the Continent.

Belgium is the country, of the 16 countries comprising the network, which uses most of the programmes offered—about 60%. The BBC accepts only about 34% and the ITA the much lower figure of 6%. However, the BBC provides many of the Eurovision programmes, in fact about 14%, and follows France and Italy, both of which provide some 20%.

The future role of Eurovision seems to lie in the rapid transmission of news from country to country, particularly when the pictures are 'live' and not filmed. It seems certain that expansion in many other directions will be limited by the different languages spoken in the eighteen countries of the European Broadcasting Union; there are obviously many programmes in which the language barrier cannot be overcome.

Our next issue, dated August, will be published on July 20th.

# MAKING PRINTED CIRCUITS

## A PHOTOGRAPHIC METHOD

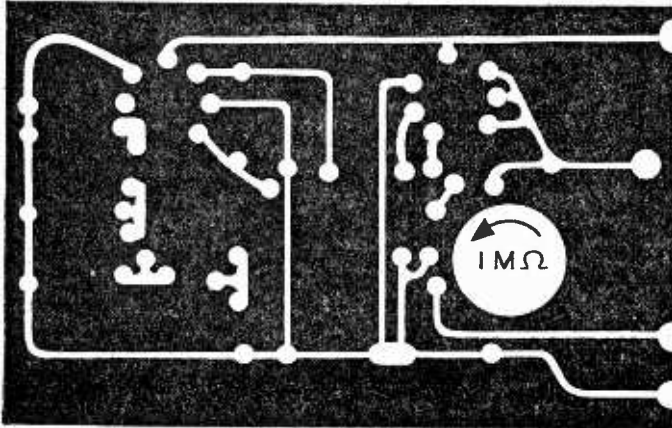

A PHOTO-RESIST  
PROCESS SUITABLE FOR  
THE AMATEUR  
CONSTRUCTOR

By N. Mears

**M**OST experimenters have at one time or another admired the excellent appearance of commercial printed circuits, and most understand the commercial reasons for their introduction. It is probable that some of these reasons have commended themselves to the amateur, notably the advantages of high reproducibility and reliability as well as the ease of working which can hardly be regarded as a vital manufacturing concern. Some may have tried their hand at using the technique for the construction of home-made apparatus, and doubtless many—like the writer—have been rather dismayed by the amateurish appearance of the finished product. However, the advantages of printed circuits are such that it was felt necessary to evolve some simple technique which would put the production of reasonably neat circuit boards within the scope of the experimenter. This article offers the results of the writer's experiments in this direction. It is not claimed that the last word has been said, however, and any reader may well be able to make improvements.

### Principles

The most widely-used circuit board consists of a plastic sheet to which is bonded a layer of copper foil. The insulating plastic sheet is usually a phenolic-paper board the thickness of which varies with the intended use; the most useful gauges for normal work lie between  $\frac{1}{8}$  in. and  $\frac{1}{4}$  in., and about  $\frac{1}{8}$  in. is probably the most popular size. In addition to phenolic-paper laminate, various other types of board are sometimes recommended for use: epoxide-glass-fibre has excellent electrical qualities, a low absorption of moisture, and can withstand relatively high temperatures; Melamine-glass is useful where a wearing surface is needed,

as in switches; and Teflon-glass can be used in micro-wave circuits where losses are very much to be avoided. Naturally the cost of these special laminates is much higher than the phenolic-paper type.

Printed circuit construction consists essentially of the removal of as much copper foil as is needed, so as to produce an insulated board covered with a network of conducting copper lines or surfaces. Since all is in one plane—or preferably nearly so—some limitations in design have to be accepted. However, with care and the exercise of some imagination the limitations imposed need only be small.

### Design

It could be argued that the design of a printed circuit apparatus is chiefly dependent on the artistic or other conception of the finished article. Certainly such practical matters as the placement of pot shafts, tuning condenser spindles, transformers and other heavy items have to be considered from the start if good appearance and accessibility are thought necessary. As a result, it is usually necessary to decide at the outset what the important factors are in the particular task in hand. When these have been well thought out, a certain embryo pattern will emerge which may then be used as a basis for further thought. At this stage the electrical factors must be investigated, and it is as well to list these.

The frequencies of the currents to be carried will govern the type of circuit board selected, the length of the conductors concerned and their spacing. The need for shielding will also have to be taken into account, especially where R.F. or I.F. transformers are to be used. The distributed capacitance of the proposed circuit elements will also be a factor.



The voltages likely to be developed at various points must also be investigated. These decide spacing between lines, and, in some cases, the type of insulating board to be used.

The current to be carried will determine the lower limit of conductor width. It must be remembered that heat developed may affect the bond between the foil and the laminate, and where heavy currents have to be carried—whether from R.F. sources or power supplies—due regard to these must be taken in deciding the width of conductors to be used.

Line width (in.)	Current for 40°C rise in temp.
0.1	7A
0.05	3.5A
0.03	2.2A
0.01	0.75A

The above table refers to copper foil about 0.003in. thick; this is a popular size and covers at 1oz per square foot. For the 2oz weight, the above figures may be doubled. When using this table it must be remembered that a rise in temperature of 40°C is about the maximum that can be tolerated, and a good margin of safety should be allowed.

#### Separation

For considerations of voltage, a "rule of thumb" is that  $\frac{1}{16}$ in. separation is sufficient for 300V. This applies only to dry air at sea level, and when humid conditions may be met, it will be as well to raise the separation to  $\frac{1}{8}$ in. for 300V. It should also be noted that peak voltages must be the criterion, and an ample margin of safety will prevent breakdowns.

The above will indicate that a considerable degree of miniaturising can be achieved without running into trouble, especially where transistorised circuits are being used.

It is useful to begin a design by setting out the actual components to be used on a piece of card the size of the finished circuit. Conductors can then be put in in pencil to arrive at a tentative layout, and it is a good idea to colour R.F.-carrying conductors in a distinctive way so that the ideal of short leads can be aimed at readily. The need to minimise cross-overs will require a good deal of altering about of the less fixed components, and eventually a reasonably good arrangement will be found. The mathematics of topology is highly complex, and fortunately is not needed in practice, since unavoidable crossovers can usually be carried out by using necessary components such as resistors and capacitors to act as bridges. It is seldom necessary to use a "jumper"—a piece of insulated wire bridging across a conductor. If more than one or two are used in a design, it usually shows that not enough effort was made to find a better layout.

#### Screening

It is not necessary to arrange for all the foil to be removed except the conductors. In fact,

especially where R.F. circuits are concerned, it is a good idea to let the foil act as a grounded sheet equivalent to the metal chassis of a conventional receiver. However, there are precautions to be taken; since metal will later be removed to isolate the conductors, this may well introduce long return paths for R.F. currents. If each R.F. circuit is laid out so that circulating currents are minimised and, more particularly, localised, much improvement can be obtained in this direction.

"Sensitive" leads may be afforded partial screening by bringing earthed foil close to it on each side, in much the same way as a screened lead is commonly drawn in a theoretical diagram. Also, the earthed foil can be used to effect closure of an I.F. transformer in the same way as does the chassis in normal construction.

When a good layout has been arrived at, the preparation of a full-size drawing can be started. For simple circuits this may not be thought necessary, but it is worthwhile if only that comparison with the theoretical diagram can be made at leisure. If the technique for preparing the printed circuit is to be merely painting the conductors with a resist ink, the drawing may even be put direct on to the laminated board. If, however, the photographic method to be described shortly is to be used, a good drawing will be needed in any case. It should be done in good black pencil on a sheet of white paper, the exact size of the circuit board to be used.

Where a component is connected to the board a special termination often called a "land" is provided; it consists of an area of approximately circular shape allowing for a good-sized fillet to secure the component lead to the foil, and should be at least  $\frac{1}{16}$ in. greater in diameter than the component lead. For the usual lead wires of resistors and capacitors a termination  $\frac{1}{8}$ in. in diameter is enough, but where flexible leads are to be soldered to the foil, at least  $\frac{1}{4}$ in. diameter should be allowed to provide for accidents.

It is unlikely that the home constructor will wish to try dip-soldering, but if he does it is necessary for all components to be mounted on the insulated side of the laminate. This is a design limitation which is normally only necessary for manufacturers, and a more flexible layout is usually possible if hand-soldering is used.

#### Preparing the Circuit Board

The method of painting the board with a resist ink ready for etching will not be described, as the procedure is obvious. It is only suitable for large circuits in any case, since the width of conductors can only be controlled with difficulty, and for any but simple circuits it represents an incredibly tedious task. Inadvertent errors take a great deal of time and trouble to rectify, and the final product is not generally very elegant. The method to be described is a photographic one, but the reader need not write it off therefore as being beyond his facilities since only the most rudimentary equipment is employed, and the chemicals used are all readily obtainable and are not dangerous. Naturally a little practice will be needed, but laminate is not used up and little but time is consumed.

(Continued on page 474)

The

# NTSC Colour TV SYSTEM

A BRIEF OUTLINE OF  
THE BRITISH ADAPTATION  
OF THIS SYSTEM FOR  
TRANSMITTING COLOUR  
TELEVISION

By J. A. Lush

**I**N 1953, a committee was set up in the U.S.A. to enquire into the relative merits and demerits of the various systems for transmitting moving images in colour which had been evolved. The system upon which they finally decided has come to be known as the NTSC (National Television Service Committee) system. It is this, in its present British adaptation, that it is proposed to describe here.

## Hue

The colour itself is its hue—magenta, blue and yellow are examples of different hues. The hue of a ray of light depends upon the wavelength of the radiations which constitute the light.

## Saturation

The saturation of a ray of light of a given hue is the degree to which it is mixed with white light—the precise meaning of the word “white” will be explained later. A strong, dark blue would be highly saturated, whereas a weak blue would have low saturation.

## Luminance

The luminance of a ray of light is what is generally known as its brightness.

It is well known that any hue may be synthesised by the addition of red, green and blue light in the correct proportions. White light, which in reality is a mixture of light of all hues, may be made by

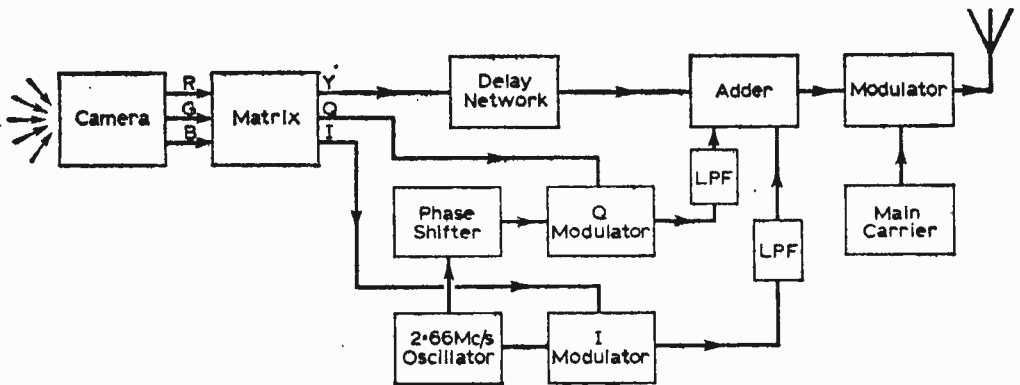

Fig. 1—A block diagram of a simple colour TV transmitter.

## Compatibility

Any colour television system must, if present conditions prevail, be compatible, i.e. colour transmissions must be receivable on a monochrome (black and white) receiver, and a colour receiver must be able to reproduce a monochrome image properly.

Before describing the actual method of operation of the NTSC system it is necessary to perform some investigation into the science of “colourimetry”. The terms in use in connection with colour television demand a little explanation.

adding one unit red of luminance 0.30 of final white and one unit green of luminance 0.59 of final white and one unit blue of luminance 0.11 of final white. This white, which is known as “illuminant C”, corresponds roughly to the light from a North sky.

## Luminance Signal

Thus if we are to produce a colour television signal which will operate a monochrome receiver we shall have to transmit a signal of which 30% of the voltage corresponds to the red in the scene, 59% to the green and 11% to the blue (this assumes

a white object). This is called the luminance signal, as in effect it contains information about the luminance of the scene before the camera.

It is not proposed to go into a detailed description of the various types of colour camera that have been devised—suffice it to say that a colour camera is capable of producing outputs which are directly proportional to the red, green and blue components

simultaneous equations (matrix equations). This is in fact done, and the other two equations—for a simultaneous equation with three unknowns requires three equations—are

$$E_I = 0.60E_R - 0.28E_G - 0.32E_B \quad (2)$$

$$\text{and } E_Q = 0.21E_R - 0.52E_G + 0.31E_B \quad (3)$$

Presented with the three voltages,  $E_Y$ ,  $E_I$ ,  $E_Q$ , an electronic computer would be able to produce the three other voltages,  $E_R$ ,  $E_G$  and  $E_B$ .

**Modulation**

As  $E_Y$  contains the information needed in a monochrome receiver it is used to modulate a carrier in the normal way.  $E_I$  and  $E_Q$  however different treatment, receive.

$E_I$ —known as the ‘I-signal’—is used to feed a balanced modulator along with an oscillation accurately held at a frequency of about 2.66Mc/s. Now, a balanced modulator is a device which, instead of having an output of a carrier with two sets of sidebands, produces the two sets of sidebands without a carrier.

$E_Q$ —the ‘Q-signal’—is used in a similar way, except that the 2.66Mc/s input is 90° out of phase with that used in the I-modulator (hence the subscripts). The I-signal is  $I_n$  phase: the Q-signal is in phase Quadrature.

**Resistor Network**

It should be pointed out at this stage that the mysterious “black box” which has  $E_R$ ,  $E_G$  and  $E_B$  fed into it, and produces  $E_Y$ ,  $E_I$  and  $E_Q$  is nothing more than a network of resistors fed from valves with high impedance outputs. It is known as the transmitter matrix.

Due to a property of the human eye, colour is only needed for large areas of a television scene, and thus we can safely restrict the bandwidths of the  $E_I$  and  $E_Q$  signals. The filters necessary for this delay the I- and Q-signals, and it is thus necessary to place a similar delay on the Y-signal, which is radiated with normal bandwidth. The I-signal is radiated from -1Mc/s to +0.34Mc/s with respect to the 2.66Mc/s oscillation (known as the chrominance sub-carrier). The Q-signal is radiated from -0.34Mc/s to +0.34Mc/s.

All the signals are now added together and used to modulate the normal VHF carrier. The sound channel is perfectly normal.

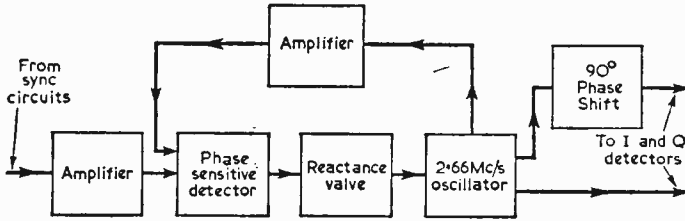

Fig. 2—Block diagram of the colour sync circuits.

of the scene. Thus if a camera were placed in front of a magenta curtain it would produce its full red output and its full blue output, but no green. A monochrome transmitter would put out a voltage corresponding to  $0.30 + 0.11 = 0.41$  of peak white.

**Voltages**

For convenience, red voltage is designated  $E_R$ , green  $E_G$  and blue  $E_B$ . The luminance voltage is known as  $E_Y$ .

Thus we can write

$$E_Y = 0.30E_R + 0.59E_G + 0.11E_B \quad (1)$$

The reader who has a knowledge of elementary algebra will realise that it would be possible to take the red, green and blue voltages and add them up in different proportions, producing a set of

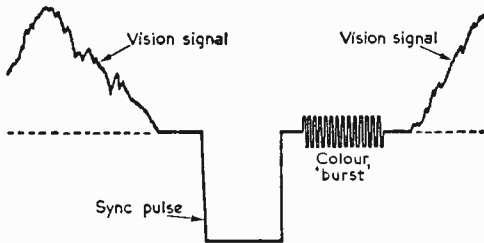

Fig. 3—Waveform showing the colour burst in the back porch.

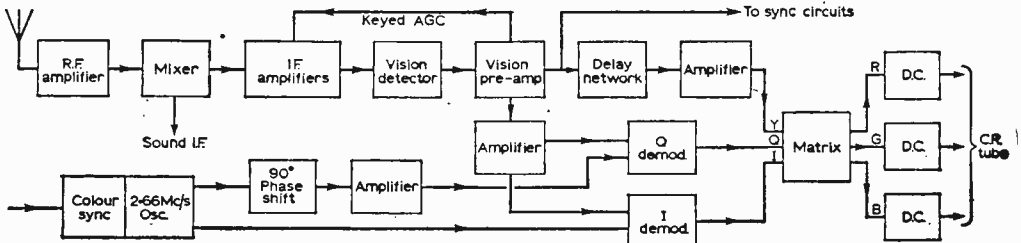

Fig. 4—Block diagram of a simple colour TV receiver.

### Replacing Carrier

If a transmitter radiates in such a way that the carrier is suppressed but both the sets of sidebands (upper and lower) are present, it will be necessary to reinsert the missing carrier at the receiver in order to resolve the transmission. This reinserted carrier must, however, have exactly the same frequency and phase as the original carrier. If it happens to be exactly  $90^\circ$  out of phase no output will be produced at the receiver detector (or demodulator). The significance of the method used in modulating the I- and Q-signals now becomes apparent. If we feed the I-sidebands and Q-sidebands into a demodulator along with an oscillation of the same frequency and phase as the suppressed carrier we shall obtain an output corresponding to the I-signal alone. Conversely, if the oscillation fed to the demodulator is  $90^\circ$  out of phase, only the Q-signal will be present at the output.

The problem now arises of how to make sure that the "locally generated sub-carrier", as it is called, has the same frequency and phase as the original one. To help us, during the back porch of the line synchronising signal, the chrominance sub-carrier is transmitted. A minimum of 8 cycles is

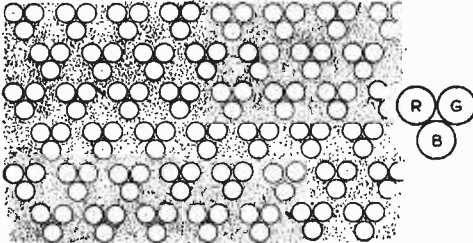

Fig. 5—How the colour dots, or colour trios, are grouped on the screen.

used (see Fig. 3). It is known as the "colour burst". It is first extracted from the sync separator by means of a circuit tuned to 2.66Mc/s. It is fed into a phase sensitive detector (Fig. 2), along with a sample of the locally generated sub-carrier.

### Reference Voltage

A phase-sensitive detector, as may be deduced from its name, produces an output which is proportional to the relative phases of the two voltages fed into it. This output, a D.C. voltage, is used to vary the frequency of the sub-carrier oscillator. Matters are so arranged that it brings it back on to the same frequency and in the same phase as the "colour burst". The sub-carrier oscillator must be relied on to keep approximately in phase when the burst is not transmitted.

We now come to the design of the actual receiver. Circuitry is more or less conventional up to the video detector. Here, however, the I- and Q-signals are taken out of the composite signal, leaving the Y-signal to continue. At this point, the block diagram of a typical colour television receiver (Fig. 4), should be consulted. It may be seen that the I- and Q-signals are amplified together in the chrominance amplifier. The chrominance sub-carrier insertion oscillator is shown, together with the circuitry necessary to synchronise it to the incoming colour burst.

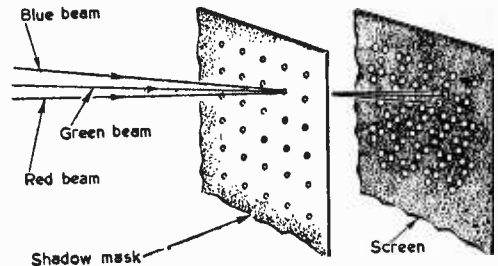

Fig. 6—How the shadow mask directs the 'red', 'blue', and 'green' electron beams on to the correct colour phosphor dots.

We now come to what is really the heart of any colour television receiver operating on the NTSC system—the I- and Q-demodulators. As we have seen before, it is necessary to insert carriers which are in phase quadrature, and this is clearly shown on the block diagram. After the process of demodulation we have two voltages, I and Q, as well as Y which has meanwhile been demodulated in a conventional video detector.

### Phase Splitters

Before we can set about producing the voltages corresponding to the red, green and blue of the original scene it is necessary to produce two signals which are  $180^\circ$  out of phase with the I- and Q-signals (that is,  $-I$  and  $-Q$ ). This is done by means of more or less conventional phase splitters, as used in push-pull amplifiers. We now have five voltages,  $+I$ ,  $-I$ ,  $+Q$ ,  $-Q$  and Y, from which we can set about obtaining, ER, EG and EB. In fact, this process turns out to be quite simple, for remembering our matrix equations, it is only necessary to rewrite them with ER, EG and EB as the subjects, and follow an exactly similar process to that at the transmitter. The section of the receiver which performs these functions is known as the receiver matrix. It now only remains to amplify and restore the D.C. components of the red, green and blue signals, and feed them to the tube.

### Tubes

Several varying types of colour television tube have been evolved, but it is proposed to describe briefly only one here—the shadow-mask type.

It must be realised that there are no technical difficulties in producing phosphors which give out red light, or green light, or blue light—the problem is how to combine them all on one screen. In fact, there are deposited on the screen a large number of three-dot groups, consisting of one speck of red phosphor, one speck of green and one of blue (Fig. 5). The difficulties of this process are obvious, and add greatly to the cost of manufacture. There are three completely separate electron guns to each of which one of the colour voltages is fed. Between the guns and the screen is a mask, pierced by a large number of holes, corresponding to each of the dot-trios. Through the holes each gun can "see" a dot of the corresponding colour (Fig. 6), clearly, there are again very great manufacturing difficulties, but these have been overcome.

# SOME WAYS AND MEANS OF CURING INSTABILITY IN TELEVISION RECEIVERS

By K. Royal

(Continued from page 440 of the June issue)

**T**HE check for oscillation, described last month, requires a good quality oscilloscope.

However, there are few experimenters with a 'scope of such desirable specifications, so other things have to be done to prove the symptom if it is not obvious.

If, for example, the oscillation is so bad as to cause a peak white screen, a quick check to prove whether the effect is caused by a defective tube or by instability is to short to chassis the control grid of the final vision I.F. amplifier valve. If normal control of brightness is then restored, one

can be sure that instability is the cause. If the symptom remains, then it is either in the brightness control circuit, video amplifier, vision interference limiter or picture tube, and normal servicing procedures should be adopted to locate the trouble.

### Tracing and Clearing Instability

Some sets are more prone to instability than others, and this applies particularly to those early TRF models which demanded elaborate inter-stage screening to maintain stability.

On such sets, a servicing operation may have required the removal of one of the screens, and a less exacting technician may have replaced it later with less than the full number of fixing screws (or it may have been left off altogether).

Poor fixing or lack of screening where it was originally included is a great encouragement for instability and, while the set may have behaved in a reasonably stable manner directly subsequent to the servicing operation, in later years, as components age, instability may well show itself for no apparent reason.

### Layout

Not only screening but the positioning of wires in the R.F. and I.F. sections of a receiver is also very important. If it is necessary to displace wires in these sections to locate a faulty component

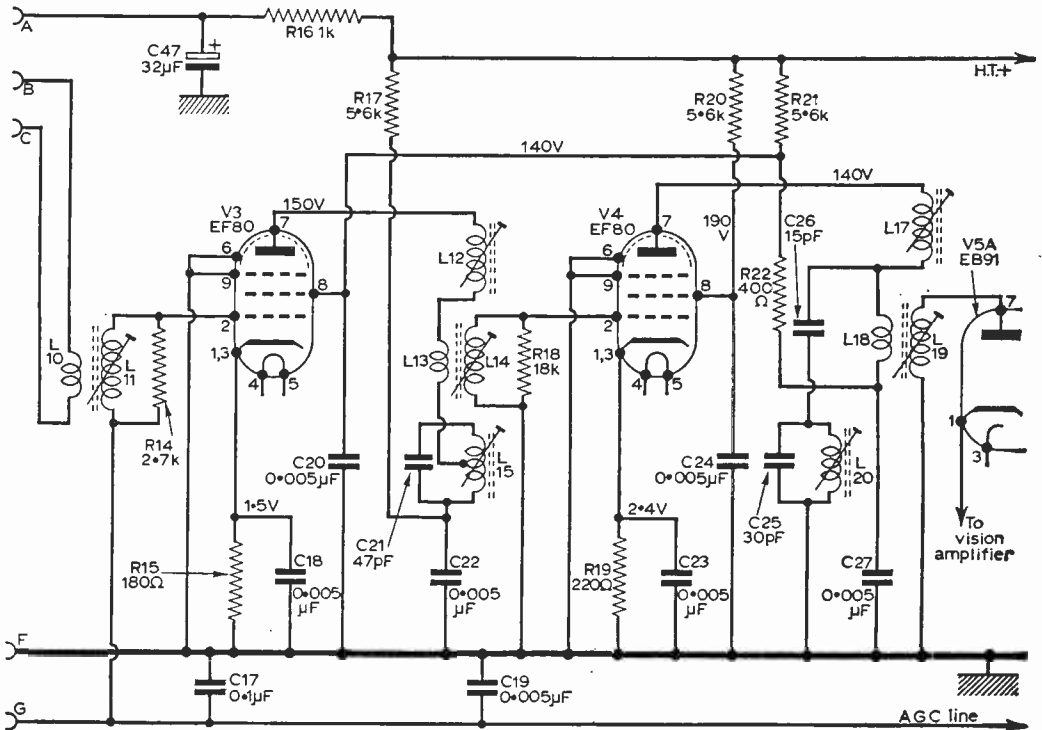

Fig. 1 (b)—The vision I.F. stages of a typical multi-channel receiver.



or to fit a new part, for instance, care should be taken to see that the wires are repositioned correctly before the chassis is fitted back into the cabinet.

However, if a receiver which has previously shown not the slightest trace of instability suddenly develops the symptoms this almost certainly signifies the breakdown of a decoupling or by-pass component—probably a capacitor.

Should a fairly old model slowly develop instability over a period of time, there is every likelihood that several decoupling capacitors in the

considered sufficient to result in instability. It can be seen, therefore, that the capacitors had developed some trouble which showed up only at the intermediate-frequency.

In Fig. 1(b) is shown the circuit of the vision I.F. stages of a typical receiver. Instability in the vision channel only should lead to a substitution check of C20, C22, C18, C23, C24 and C27 (remove the suspect and connect a test component with the shortest possible wires).

The circuit of the sound channel is given in Fig. 2 and it will be seen that the sound is taken

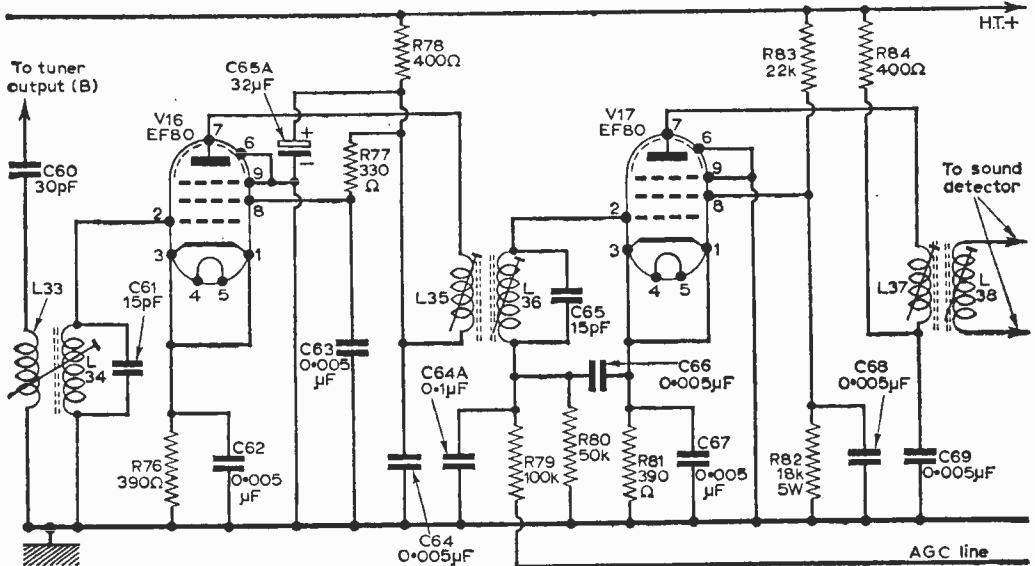

Fig. 2—The sound I.F. channel.

sound or vision channel—whichever is affected—have deteriorated.

A five-year-old set was recently examined for sound channel instability and details of the servicing procedure are worth relating. The set was brought in with low volume sound, which was soon proved to be misalignment of the sound I.F. stages. However, realigning the transformers to the correct I.F. caused the sound channel to go unstable. There is little doubt that the previous repairer, unable to clear the instability by any other means, simply detuned the I.F. transformers as a palliative, thereby removing the oscillation but severely reducing the sound sensitivity.

Eventually, each decoupling capacitor in the sound channel was replaced in turn, replacing the original in each case since it appeared not to be faulty. The trouble persisted. Finally, it was found necessary to replace all the capacitors serving as decouplers in the sound channel to restore stability and to allow the I.F. transformers to be aligned correctly.

The trouble could not be attributed to just a single component, and subsequent tests on the capacitors failed to reveal any definite trouble. They all possessed capacitance, and although some were a little down in value, this was barely con-

off from the tuner output (point B of L10 in Fig. 1(b)—see also Fig. 1(a), given last month). Thus, trouble in the sound channel only should lead to similar tests on C62, C63, C64, C66, C67, C68 and C69. Remember, if the trouble persists, it may be necessary to change several or all the capacitors together. In obstinate cases, it usually pays to do that anyway, for the cost of half a dozen 0.001µF or 0.005µF capacitors is insignificant compared with the time that it could take to locate the trouble by other methods.

<b>JOIN THE PRACTICAL GROUP</b>	
<b>PRACTICAL WIRELESS</b> ... ..	2/-
Every Month	
<b>PRACTICAL MECHANICS</b> ... ..	1/6
Every Month	
<b>PRACTICAL MOTORIST</b> ... ..	1/6
Every Month	
<b>PRACTICAL HOUSEHOLDER</b> ... ..	1/3
Every Month	

# Telenews

## Television Receiving Licences

THE following statement shows the approximate number of Television Receiving Licences in force at the end of April, 1962, in respect of television receiving stations situated within the various Postal Regions of England, Wales, Scotland and Northern Ireland.

Region	Total
London .. .. .	1,983,171
Home Counties .. .. .	1,674,850
Midland .. .. .	1,763,742
North Eastern .. .. .	1,890,443
North Western .. .. .	1,557,433
South Western .. .. .	1,019,970
Wales and Border Counties .. .. .	717,806
<b>Total England and Wales .. .. .</b>	<b>10,607,415</b>
Scotland .. .. .	1,079,446
Northern Ireland .. .. .	179,490
<b>Grand Total .. .. .</b>	<b>11,866,361</b>

## TV Studio for The Royal Scottish Academy of Music

ON May 24th this year, the College of Dramatic Art of the Royal Scottish Academy of Music opened its new television studio in Glasgow, and in so doing provided its students with amenities possessed by no other such organisation in Britain.

The television equipment, which has been supplied and installed by Marconi's, incorporates every facility for the production of small-cast plays. The studio and the control room are simplified counterparts of those used by television broadcasting organisations.

The cameras, the control room, the lighting and the ancillary equipment will all be manned by students, who will in this way get the "feel" of the television medium at first hand and have direct experience of its advantages and limitations in the matter of play production. They will be able to experiment with new techniques of presentation and, in the field of acting itself, gain invaluable experience in performing in front of cameras and

mastering the many other aspects of television studio work.

The enterprise is a practical expression of the forward-looking policies of the Royal Scottish Academy of Music, and one which should prove of considerable value in the overall training given to students in both the dramatic and the musical fields.

## Canada to Make Colour TV Recordings of Surgical Operations

ONE of the most interesting features in the new extension to the Halifax, Nova Scotia, Infirmary, is the provision of an EMI closed-circuit colour television camera system which can be brought into use in any one of four operating theatres.

Permanent visual records of surgical operations will be kept by means of a video recorder which will store information in colour on video tape. This tape

can be played back at any time either in colour or monochrome.

Designed so as to be readily transportable from one operating theatre to another, the colour camera will be used to observe operations via a remotely-controlled mirror mounted on a boom over the operating table. This camera will be under the control of a local cameraman—usually a member of the hospital medical staff—who will at all times be able to keep the operation under the closest observation.

A second television camera—transmitting black and white pictures—will also be used to observe operating procedures in four of the operating theatres. This camera is provided with a remotely-controlled pan and tilt head.

Video signals from both cameras are transmitted to a control room in the basement where the camera switching takes

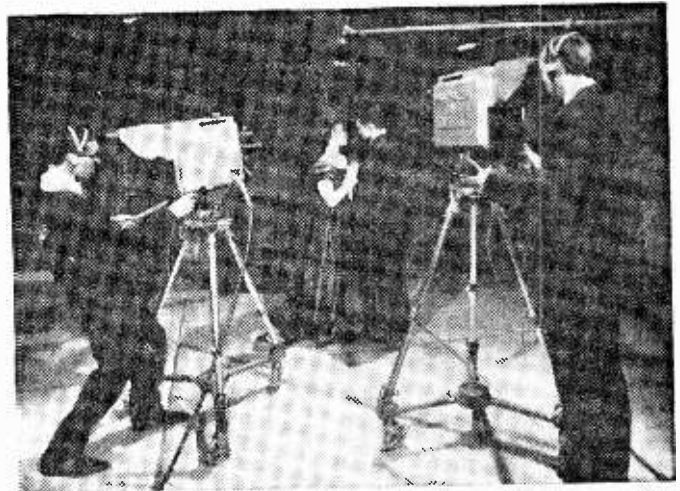

Fig. 1—A rehearsal in progress in the new TV studio of the College of Dramatic Art of the Royal Scottish Academy of Music in Glasgow.

place, and the resulting picture is then routed to an adjoining lecture room, where it is displayed on a 8ft by 6ft screen by means of a colour television projector.

Provision is also made for a monochrome television camera in the autopsy room and for a colour camera in the maternity section of the hospital. Since the lecture room containing the large screen is restricted in the accommodation of students an additional colour receiver will be placed in a second auditorium.

An audience in the lecture room will be able to listen to the voice of a surgeon or commentator during an operation, and the lectern in this room carries remote switching for raising and lowering the screen, dimming or extinguishing the lights and controlling the amplifier.

#### Wired Television for Luton

MORE than 100,000 television viewers in Luton whose reception has always been marred by weak and fading pictures will soon be able to receive strong, clear television and sound broadcast signals from the wired television system recently supplied by EMI Electronics Ltd.

Bands I, II and III will be covered and, although Luton is almost 40 miles from the nearest transmitter, subscribers will enjoy good reception of BBC London TV programmes, London and Anglia ITV, BBC VHF Home, Light and Third sound programmes and Radio Luxembourg, which will be received direct and redistributed in the VHF band.

Extra channels, colour television, pay TV and the much-discussed 625-line standard can all be received by the equipment.

#### Kenya to have Television

KENYA is to have television before the end of this year and has bought British equipment to establish the public service.

Marconi's have been entrusted with the order for the supply and installation of the main items of transmitting and studio equipment.

The transmitting equipment will include a 5kW vision transmitter, a 1kW sound transmitter, a 3-stack super-turnstile aerial, programme input equipment, a filterplexer, a water-cooled test

load, harmonic attenuators and a considerable quantity of other ancillary equipment.

The studio equipment will comprise three Mark IV image orthicon camera channels, four vidicon camera channels, a transistorised sound control console Type BD968, picture monitors, some master control equipment, film projectors and ancillary

Signalling School, Secunderabad, Andhra, will note the numbers of railways wagons as they are moved in sidings.

#### New TV Station at Manningtree

THE new television station near Manningtree, Essex, was brought into service by the BBC on May 22nd.

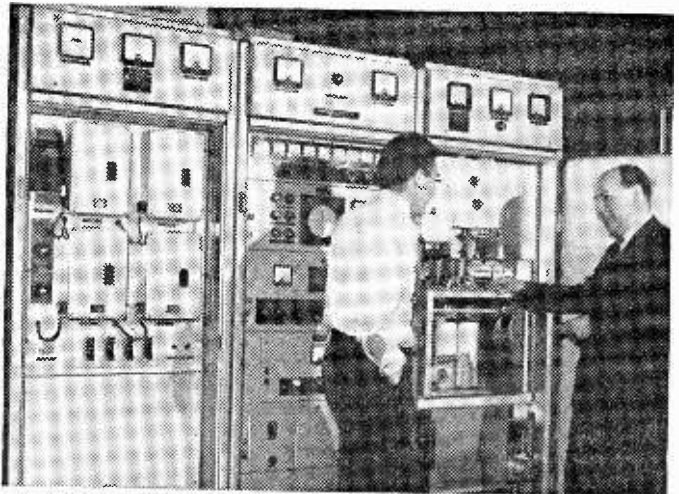

Fig.2—Mr. W. J. Morcom, the Marconi Company's Chief Transmitter Engineer, inspecting a 5kW vision transmitter which forms part of the order which Kenya has placed for Kenya's first television service.

equipment. One of the camera channels will be used in the announcer's studio and the others for telecine purposes.

The transmitting station will be sited at Limuru, some 11 miles north-west of Nairobi (line of sight) and the studios will be in Nairobi itself. The station will operate in Band I on lines to CCIR standards. The service is expected to be in operation by October 1st.

#### Closed-Circuit TV to be Used on Indian Railways

AN EMI closed-circuit television system will help to speed the flow of goods on Indian railways. The Gramophone Company Ltd., Dum Dum—a member of the EMI group of companies—has been awarded a contract to supply closed-circuit TV equipment to the Central Railway, Bombay.

The television system, which will be used in the All-India Telecommunication and Railway

This station will improve reception for some 350,000 people in South-East Suffolk and North-East Essex, including those in Ipswich, Woodbridge, Felixstowe, Harwich, Clacton-on-Sea, Colchester and Hadleigh who have hitherto received a fringe area service from the BBC's television station at Crystal Palace or Tacolneston (Norwich).

The Manningtree station, which has been designed to work without staff in continuous attendance, receives its programmes from Tacolneston. The vision signals are picked up at the Post Office receiving station at Wickhambrook, from where they are sent to Manningtree over a radio link, and the sound component is fed from Tacolneston over Post Office lines. Manningtree retransmits the programmes on Channel 4 (vision 61.75Mc/s, sound 58.25Mc/s) with horizontal polarisation, which means that viewers' receiving aerials should be mounted horizontally.

# SERVICING TELEVISION RECEIVERS

No. 80—REGENTONE TEN-17

By L. Lawry-Johns

(Continued from page 423 of the June issue)

THE resistor R46 (Fig. 5), in this receiver, is prone to overheating and the permanent remedy for this—as described last month—is to replace it by a wire-wound component.

### EHT Section

To return to the “no-picture—no raster” condition, if the line timebase whistle is audible and a glow is induced into a neon when brought near to the top cap of the EY86, or a blue glow appears when a screwdriver blade is brought to the insulated top cap of the EY86 and yet this valve does not light, it is reasonable to assume that the valve is defective with an o.c. heater.

### EHT in Order

If the line timebase is working and EHT is

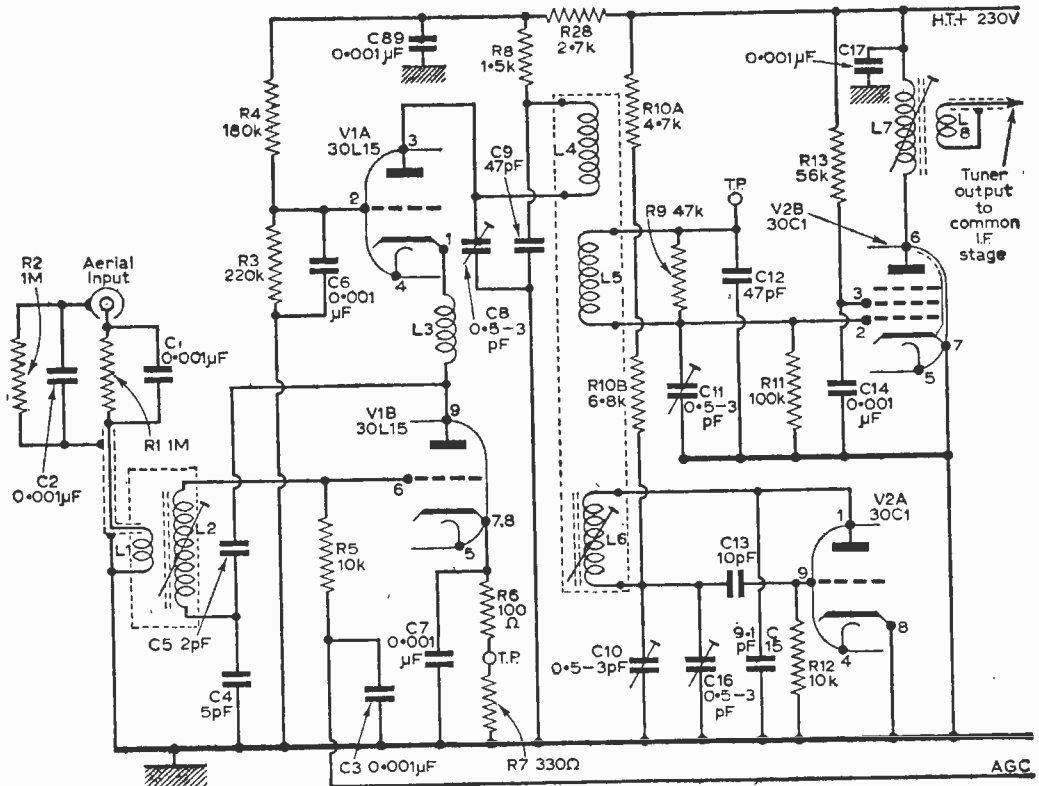

Fig. 4—The circuit of the tuner unit.

being supplied to the tube, and yet there is no raster obtainable, the next step is to check the voltages applied to the tube base socket. Pin 7 is the cathode pin and the video signal is applied to this from the anode of V5 (pentode section) (see Fig. 2 last month), the D.C. level being held fairly constant by R94 (330k) and R50 (120k). The actual D.C. voltage at pin 7 will vary a little around 100V. The voltage at pin 2 (the grid or control electrode) should approximate to this figure when the brilliance control is fully advanced. If the voltage falls far short of this, however, and a temporary link between pins 2 and 7 produces a bright raster, the indication is that either the brilliance control is defective, R52 (180k) has gone high in value, or C48 (0.04μF) is leaky.

If pin 7 is held at 150V or a little over, attention is directed to R50 which can also go high in value. These are not the only important voltages, however, and it is also necessary to check the first anode voltage at pin 3 which should be (very approximately) 350. If a meter of low sensitivity is used, say less than 5k/V, this reading cannot be expected, since the shunting effect of the meter will drop the voltage considerably and a neon check will be of more value. An approximate voltage of 350 will obviously cause a neon to glow much brighter than the normal 230V H.T. line which can be used for comparison. If the voltage is much lower than that expected, it is best to check the focus electrode voltage at pin 4 before going any further. The focus control is

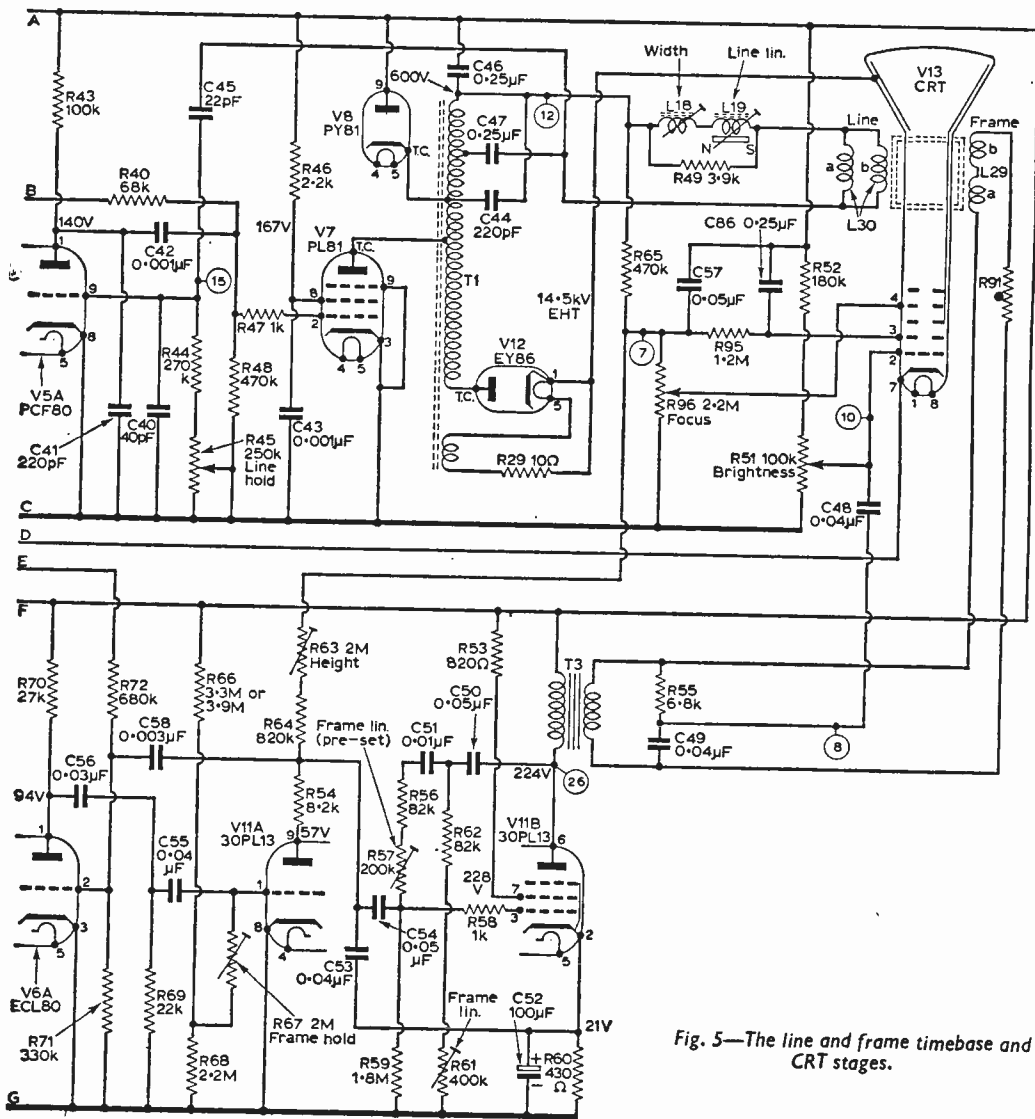

Fig. 5—The line and frame timebase and CRT stages.



R96, a slider element at the tube base. It is connected to chassis at one end and to the boosted H.T. line at the other. When fully advanced, therefore, the voltage at pin 4 should be about 350, the same as at pin 3. If this voltage is correct, but that at pin 3 is low, check C86 0.25 $\mu$ F which may be leaky and check R95 (1.2M). If the voltage at pin 4 is also low, it is prudent to disconnect the focus control element and recheck at pin 3 as these 2.2M focus elements often change in value

causing low voltages at the tube and to the height control also causing loss of height.

If the focus element is not at fault check C57 (0.05 $\mu$ F) which can short to the H.T. line bringing the voltage on this line down from about 350 to 235.

**Raster in Order, No Picture, No Sound**

If advancing the brilliance shows a raster, but there are no signals at any position of the channel selector, it is highly likely that one of the valves in the tuner unit is at fault, probably the 30C1 (PCF80) but possibly the 30L15. If replacement valves fail to restore signals, check V3 and the voltage supplies to pins 7 and 8. It will then be necessary to check the tuner unit voltages. If R15 (180 $\Omega$ ) is burnt out, check C17 (0.001 $\mu$ F) in the tuner unit for shorts.

**Picture in Order, No Sound**

Check V10 PCL82 which is most likely to be at fault, and if there is no sign of life from the loudspeaker at all check the voltage at pin 6 of the PCL82 (224). If this is absent, the sound output transformer is almost certainly at fault, the primary being o.c.

**Distorted Sound**

Check R83 (1.8M) to MR4, V10 (PCL82) which may have an internal short, and C61 (0.01 $\mu$ F) for leakage which will put a positive voltage on the pentode section control grid (pin 3). Also check R76 (330 $\Omega$ ) and C88 (100 $\mu$ F).

**Frame Timebase Faults**

A horizontal white line denotes that the frame timebase is inoperative. Check V11 (30PL13). If this is in order, check the voltage to pin 6 (224) as the frame output transformer primary may be o.c. It is also as well to check the condition of R60 (430 $\Omega$ ) which can be burnt out by an internal short in V11.

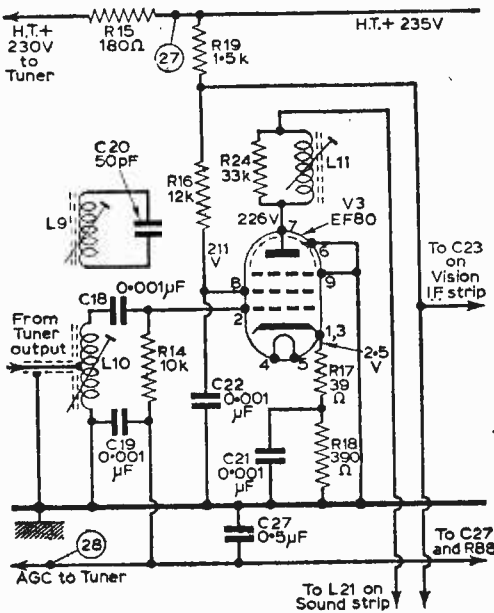
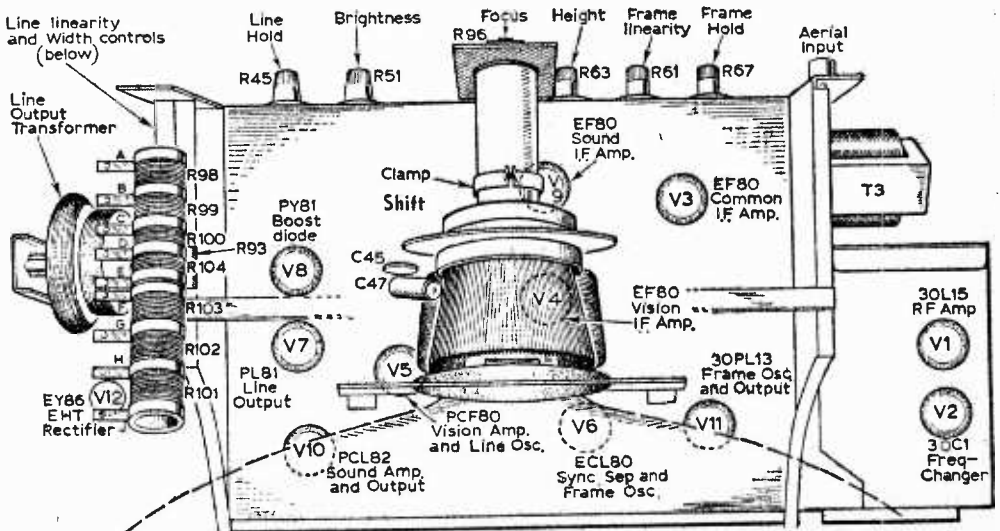

Fig. 6 (above)—The common I.F. stage.

Fig. 7 (below)—The component layout above chassis.



### Lack of Height

If there are equal gaps top and bottom, check R64 (820k) which may be high in value. Also check C57 (0.05 $\mu$ F). If there is bottom compression, check V11, R60 (430 $\Omega$ ) and C52 (100 $\mu$ F). R60 sometimes changes in value and C52 can go o.c. Note the effect of the linearity control (R61) and the pre-set linearity (R57), as these will have to be reset when a new 30PL13 is fitted.

### Frame Hold

If the frame hold control is at the end of its travel and the picture continues to roll, check R66 (3.3M or 3.9M), V11 and V6.

### Small Picture

If the picture lacks both width and height check the H.T. voltage (235 approximately). If this is low, check MR2 (silicon power diodes) on the front end of the chassis. A single Radiospares type 51 will replace both the FST1/4's. The positive end of the type 51 is marked with a red dot and this must be connected to C74/L31. If the H.T. is in order (say over 220V), check the PL81 and the timebase valves generally.

### Line Hold

If the line hold is at the end of its travel, check V5 (PCF80) also R44 (270k to pin 9 of V5).

### Weak Picture Lacking Contrast

If this is experienced on both channels, check V5 (pentode section is video amplifier), R31 (10k) and MR1 (0A70 crystal diode detector). Also check the continuity of L15, although an open circuit in this usually causes complete loss of picture signals, leaving a raster when the brilliance is advanced.

### Inoperative Contrast

Weak signals will cause the contrast to be inoperative since the control voltage is obtained

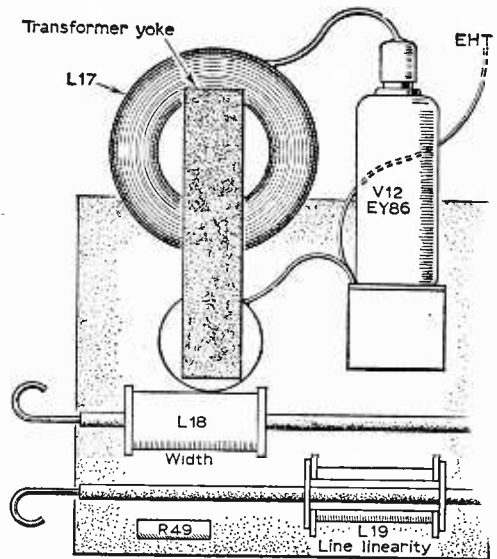

Fig. 8—The line output transformer and width and linearity coils.

from the sync separator and the negative voltage at this point depends upon the output of the video amplifier. Therefore, it should be ensured that the condition applies to both channels and is not due to low signal amplification.

Then check R84 (4.7M), C36 (0.1 $\mu$ F) and C27 (0.5 $\mu$ F). The control could be o.c. at one end but this is not usual. Check the controlled valves V1 and V3 either of which could have an internal leak cancelling the control voltage.

## Making Printed Circuits

(Continued from page 463)

The outline of the procedure is as follows: The copper foil is covered with a thin layer of resist material; this is insoluble in water but soluble in an organic solvent such as methylated spirit. On top of this is laid a light-sensitive layer which, after exposure to light, is insoluble in water or in methylated spirit, but, where unaffected by light, remains soluble in water. Thus, when a transparent drawing of the circuit is placed over the prepared board and the whole is exposed to light, the dark parts in the drawing shield the light-sensitive layer, while the light parts of the drawing allow light to harden the layer. Development of the exposed plate is done in warm water; this dissolves the unaffected part of the layer and exposes the spirit-soluble resist below, while the resist layer is protected from the action of spirit

by the hardened layer above. All that is now needed is to dissolve the exposed resist with spirit, and the board is ready for etching. In fact the whole procedure only takes a very short time to carry out from beginning to end, *once a good drawing has been prepared.*

The materials needed are as follows: 1oz powdered gelatine,  $\frac{1}{2}$  dram crystal violet,  $\frac{1}{2}$ oz ammonium bichromate (potassium bichromate will do but is not quite so effective although easier to obtain). The above can all be obtained at the local chemist's shop. One tin ( $\frac{1}{2}$  pint) 'Glitseal' polish, obtained at the nearest 'do-it-yourself' shop, or 1oz shellac, and a pint of methylated spirit complete the chemical side of the equipment. In addition, it will be necessary to have some detail (tracing) paper or better still Kodatrace or Permatrace paper, black Indian ink and some drawing instruments and brushes.

(To be continued)

**Introducing the J.B. Range of Transistors**

Try these! You will be very pleased—  
**JB1. All wave mixer** (replaces OC45 etc.) .. 6/6  
**JB3. I.F. Amplifier** (replaces OC44 etc.) .. 4/6  
**JB4. A.F. Driver** (replaces OC81D etc.) .. 5/-  
**JB6. Output matched pair** (replaces OC81 etc.) .. 13/-  
 Special offer set of six matched for superhet .. 25/-  
 Special offer set of four matched for Amplifier (1 watt) .. 17/-

**Transistor for R.F., F.M., TV and U.H.F.**

Frequencies quoted are approx. cut-off.  
**SB 079, 15-20 Mc/s.**..... 8/6  
**SB 306, 20-30 Mc/s.**..... 9/6  
**SB 231R, 40-50 Mc/s.**..... 15/-  
**American 2N1727, 100-150 Mc/s.** 15/-  
**American 2N1728, 100-150 Mc/s.** 12/6  
**American 2N1747, very high gain, ideal for 30/40 Mc/s. I.F. stages** .. 22/6  
**American T1832, 1,000-1,300 Mc/s.** 25/-  
**American T1833, 1,000-1,300 Mc/s.** 26/-

**Transistorised Pre-amp**

As described April and May. Complete set of parts including U.H.F. Transistors. Price 70/-

**TRANSISTOR COMPONENTS**  
 Send S.A.E. for our new price list, just printed.

**LAST OF THESE BRAYHEAD TURRET TUNERS**

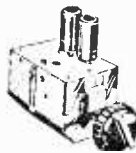

Complete with Band 1 and Band 3 coils. New but removed from unused equipment. Less valves 15/- each or with valves 25/- each. Post 2/6 (Knobs 3/6 extra).

**CLOSED CIRCUIT TV**

If you feel like taking a day out we invite you to our studio here at Eastbourne and will demonstrate 406 and 625 systems, as well as under water and other types of installations. We have equipment for sale or loan, and will be glad to discuss any proposals which you may have. You will be interested to note that a transistorised camera for working direct into a domestic TV receiver can now be purchased for little more than the cost of a good photo camera.

**THIS MONTH'S SNIP**



**I.F. STRIP**, suitable for TV or for breaking down. Must have cost the Government at least £20. Contents: Over 50 paper tubular and mica condensers values up to 5 mF. Over 50 carbon resistors, various wattages and values—6 Yaxley switches—6 I.F. transformers, dust covered suitable for TV or rewinding—7 octal valve holders. Many useful sundries—chokes, valve top clips, tag boards, plugs, switch, springs, etc., weighs 6 lbs. Secure one of these whilst stocks last, price only 9/6, plus 3/6, postage and packing. Complete set of valves for above unit, 25/-.

**"The GOOD COMPANION" Mk. II**

using Transistors



In the "de-luxe" cabinet as illustrated it costs £10.19.6 to build—but what a set! Scan these pages, you will find nothing to compare with its specification. It uses transistors instead of I.F. transformers, has variable feedback as well as all the usual features, A.V.C., Push-pull output, Ferrite Aerial, Slow Motion Tuning, etc., and is a very powerful Medium & Long Wave set, conservatively rated at 750 mW. Every component used is by a famous maker, such as American Philco MADT R.F. transistors—Mullard A.F. transistors—Jackson Brothers' tuning condensers—Rola-Celestion loudspeaker—Dubiller—T.C.C. Morganite resistors and controls. Also full after sales service available. You will definitely be doing the right thing if you buy a Good Companion.

**ELECTRONIC PRECISION EQUIPMENT LTD.**

• Orders received by post are despatched from our warehouse, Dept. 5, 66 Grove Road, Eastbourne, and to save time, please post your order to this address. Please include enough for postage. Callers, however, should use one of the following addresses:  
 520 High Street North 42-46 Windmill Hill 266 London Road 29 Stroud Green Road 246 High Street  
 Manor Park, E.12 Ruislip, Mdx. Croydon Finsbury Park, N.4 Harlesden, N.W.10

**Diamond**

all NEW T.V. replacement Tubes

**BRITAIN'S FINEST**

ONLY THE GLASS IS NOT NEW. Diamond T.V. Tubes are RE-SCREENED, RE-ALUMINISED and fitted with the LATEST BRITISH GUN ASSEMBLY. They re-vitalise your TV and give greatly improved definition and brilliance.

GUARANTEED TWELVE MONTHS—ALL TYPES ex STOCK.

Write for details today to:—

**DIAMOND ELECTRONICS CO.**

Siron Works, 96a Wellington Street, MANCHESTER 18.  
 Tel.: EASt 3669.



and what Prices!

12" — £4.10.0

14" — £5.5.0

17" & 15" — £5.15.0

ALSO 19", 21" and 23"  
 Carriage and Insurance 7/6

C.O.D., C.W.O. or Proforma invoice

10/- REFUND ON YOUR OLD TUBE

If you have any technical problems, we will be glad to assist you.

# LASKY'S RADIO

## 90° 17in. T.V. CHASSIS

As advertised last month. Few only still available. Chassis complete with 14 valves, tuner, etc. Less C.R.T. and line transformer.

**LASKY'S PRICE £14.19.6** Carr. & Ins. 7/6

As above with C.R.T. 19 gns. Carr. & Ins. 19/6.

Chassis less valves, C.R.T. and Line Output Transformers, 99/6. Carr. 7/6.

C.R.T. type C17AF, £8.19.6. Carr. & Ins. 19/6.

Line Output Transformers, not original type, 29/6. Post 2/6.

S/vison chassis 38 Mc/s. Printed circuit with all valves, £5.19.6, less valves 59/6, post 5/-.

## NEW C.R. TUBES

All sizes in stock at lowest Prices, 17in. from 79/6. Send for list.

**FERRANTI** 17in. type TR17/10, 6.3 v., 0.3 amp. heater. New and unused £5.19.6. Carr. & Ins. 12/6.

## REGUNDED C.R. TUBES

GUARANTEED for 12 MONTHS

Type	Carr. & Ins.
12in. round	£5 10 0
14in. rect.	£5 10 0
15in. & 16 round	£5 19 6
17in. rect.	£5 19 6
21in. rect.	£7 19 6

# LAST SIX WEEKS!

## Rebuilding Clearance Sale

at 42 Tottenham Court Rd., W.1

**OUTSTANDING BARGAINS IN RADIO AND T.V. RECEIVERS, COMPONENTS, ACCESSORIES, TAPE RECORDERS, MICROPHONES, VALVES, C.R.T.'S, and INNUMERABLE ODDMENTS. FOR THE EXPERIMENTER, HOME CONSTRUCTOR etc.**

**CALL EARLY. Your last chance to find the bargain you have been looking for.**

# LAST SIX WEEKS!

207 EDGWARE ROAD, LONDON, W.2.

PADDington 3711/2.

33 TOTTENHAM COURT ROAD, W.1.

MUSEum 2605

BOTH OPEN ALL DAY SAT. Early Closing Thurs. Mail Orders to Dept. P.T., Edgware Road

## Prices Slashed!

### MAKER'S SURPLUS COMPONENT BARGAINS

WIDE ANGLE 38 m.m.	
Line E.H.T. Trans. Ferroxc	
9-16 kV	12/8
Scanning Coils	12/8
Frame Output Transformer	5/-
Frame or line block osc.	
Transformer	3/6
Focus Magnets Ferroxc-core	7/6
P.M. Focus Magnets, iron-core	6/6
Duomag Focalsers	8/8
300 m/a Smoothing Chokes	7/6

**REMOTE CONTROL UNITS** Comprising On/Off switch, Brightness and volume controls. Controls are recessed into smart grey plastic case, fitted with 15 feet of 7 way multi cable, in grey p.v.c. Listed at £2.20.

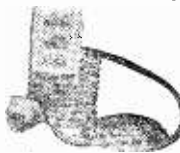

**LASKY'S PRICE 14/11. Less THAN HALF PRICE.**

Six Section Telescopic Aerial 27in. open, 1in. projection when closed, chrome plated, strongly made. Ideal for transistor portables remote control models. Today's value 17/6. Lasky's Price 7/11.



## "SABRINA" STILL WELL IN FRONT

Make your TV set 100% again before Prices rise. (You have been warned!)

### COMPLETELY REBUILT C.R. TUBES ALL TYPES (including electrostatics)

12" now ...	£5. 0.0	} For Single Tubes
14" to 17" now ...	£5.10.0	
21" now ...	£8. 0.0	

ALL C.W.O.—TRADE SUPPLIED

Special Bonus Scheme for Service Engineers—Reducing to:

12"—87/6; 14"/17"—97/6; 21"—147/6

FREE Pass. transit & Ins. anywhere in British Isles or N. Ireland (12 months' guarantee).

## SABRINA C.R. TUBE CO.

Electron Works, North Bar

BANBURY, OXON

Telephone 2390

## EDDYS (Nottm.) Ltd.

DEPT. P.T.

172 ALFRETON ROAD NOTTINGHAM

New or Surplus Valves Guaranteed and Tested by Return Post.

AC2/PENDD	EZ41 6/9	IR5 5/6	6V6G 4/9
C1C 7/6	EZ80 5/11	5U4G 4/9	6V6GT 4/6
CY31 9/6	EZ81 6/6	5Y3G 5/11	6X4 6/-
CL33 11/9	GT1C 5/-	6AC7 3/3	7C5 6/11
EB41 4/11	HL23DD 6/6	6AG5 3/6	7C6 7/11
EB91 3/6	KT33C 6/6	6C4 3/6	10F1 5/-
EBF80 7/9	MU14 6/-	6BW7 6/11	10P13 9/6
ECC85 5/11	PCF82 7/11	6F1 5/-	12A6 5/-
EF36 3/-	PCL82 8/6	6F15 5/-	12K7 5/3
EF37 4/6	PY83 7/6	6F33 6/6	12Q7 5/7
EF41 7/6	PEN46 4/11	6F5G 2/9	20D1 8/6
EF42 7/6	PEN36C 8/-	615GT 3/3	20P3 12/6
EF50 1/9	PL33 9/6	615M 4/3	25B8G 6/11
EF86 8/11	PL36 10/6	6K7G 1/11	25L6GT 7/11
EF91 3/6	PZ30 9/6	6K8G 5/6	30F5 6/11
EF92 4/6	R19 11/-	6P25 8/6	35L6GT 8/6
EF94 7/11	SP61 2/6	6P28 9/6	35W4 6/9
EL38 12/6	TDD4 7/6	6Q7G 5/11	35Z4 5/3
EF183 12/6	UB41 7/6	6S7G 4/9	50CD6G
EF184 12/6	VP23 6/6	6SA7M 5/9	19/11
EF81 12/6	ID5 7/6	6S7JM 5/9	80 6/11
EF91 4/-	IL4 3/3	6SL7GT 5/11	954 1/6
EZ40 5/11	IT4 3/6	6SN7GT 4/6	955 3/6
	IS5 4/9	6U4GT 10/6	956 2/6

**NIFE ACCUMULATORS.** 1-25v., size 3 x 2 1/2 x 3/4 in., weight 13 ozs. 2/11 each. P. & P. 2/-. One only add 9d. per cell.

**VIBRATORS.** 12 volt 4 pin 5/11; 6 volt 4 pin 8/11. Post 1/6.

**VALVES, ex equipment.** EF80 9d. ea, 5 for 2/11; 10F1 9d. ea., 5 for 2/11; EB91 9d. ea; 6F15 9d. ea; 6F33 6d. ea; EF36 6d. ea; 20P1 2/6 ea; EF50 6d. ea; 6F1 9d. ea; PZ30 3/6 ea. Post 6d.

Any parcel insured against damage in transit for only 6d. extra per order. All uninsured parcels at customers risk. Post and Packing 6d. per valve extra. C.W.O. or C.O.D. only. C.O.D. Charge 3/- extra. S.A.E. with enquiries.

# SERVICING DATA AND MODIFICATIONS

By D. Elliot

## FUSES IN LINE OUTPUT STAGES AND TUNER CIRCUITS

(Continued from page 436 of the June issue)

**L**AST month various ways of checking the line timebase were discussed, and an oscilloscope test for the line output transformer was also described. There is one more point, however, that should be brought to light and that is, some sets feature a 250mA fuse solely to protect the line output stage in the event of a short-circuit or lack of line drive.

### Line Output Stage Fuse

Such a fuse is shown by F101 in the circuit section in Fig. 20 (from the Ferguson 203T series). It will be seen that the whole of the H.T. supply for the line amplifier valve V10 and the booster diode V9 is directed by way of the fuse, so that its failure would affect only the line timebase, leaving the rest of the set working normally. The symptoms, therefore, would be "sound normal—no raster". This could easily be put down to trouble in the line timebase as discussed last month and, unless one was aware that such a fuse existed, quite a lot of time could be wasted in checking around the transformer and associated components. Nevertheless, the fuse (and trouble) should soon be detected when it is realised that the amplifier is without H.T. voltage.

Sets other than the Ferguson series mentioned may also use a fuse of this kind, but in the Ferguson it is mounted vertically below the horizontally-mounted main fuse on the mains voltage adjustment panel, as shown in Fig. 21. It can be checked very quickly with the set switched on and connected to the power supply, simply by measuring H.T. voltage first one side of it and then the other. Lack of voltage on one side will, of course, prove that the fuse is open-circuited.

### Faults

There are several factors which are likely to cause a fuse in this position to blow. One, of

course, is a definite short-circuit somewhere in the line amplifier, such as a short in the line output transformer or valves. However, as the fuse is fairly lightly rated (i.e., 250mA) it is vulnerable to failure on the slightest rise of H.T. current, and factors other than a definite short-circuit often cause it to blow—one is a momentary current surge in the line output valve V10. While a current surge of this nature may not itself be harmful and may not indicate that the valve is defective, it can often cause frequent fuse replacements, thereby, in effect, detracting from the reliability of the receiver.

Apart from a short-circuit and current surges, the fuse would also fail should the drive from the line oscillator to the line amplifier cease. Although it is good to have protection against definite faults, bearing in mind that lack of drive or a short-circuit could result in costly valve line output transformer damage, or both, many technicians feel that the unreliability arising from normal current surges outweigh the advantages of the fuse, and as a

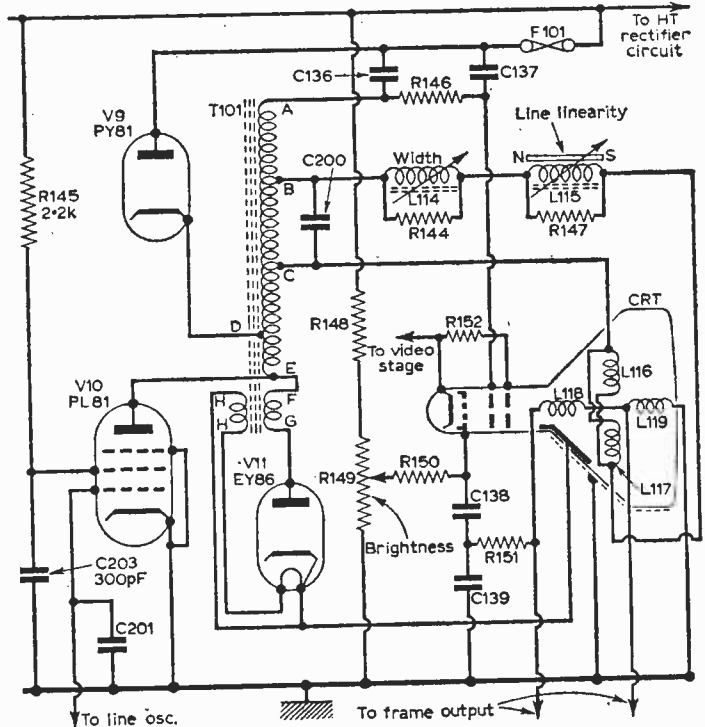

Fig. 20—The line output stage of the Ferguson 203T series, showing the position of the line amplifier fuse, F101.



consequence either increase its rating to 500mA or so, or short it out completely. Such procedure has, in fact, been recommended by the manufacturer, but it is strongly suggested that this is not adopted simply to mask a defect, for frequent failure of the fuse could indicate an intermittent short or lack of line drive.

### Ferranti Models T1225 and 14T2

In some of these models, sufficient brightness cannot be achieved by fully advancing the brightness control, depending upon the characteristics of

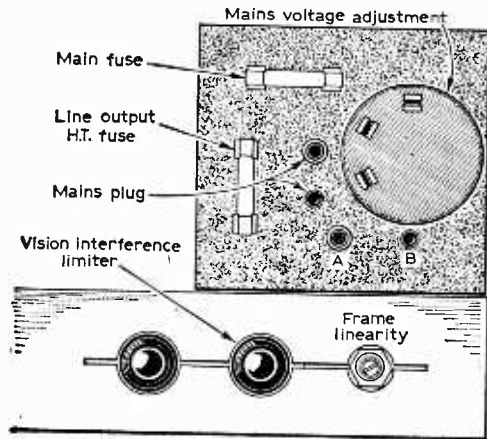

Fig. 21—The position of the F101 fuse on the chassis of the Ferguson 203T series receivers.

the picture tube. This can be corrected by connecting a 10k resistor between the earthy end of the brightness control and chassis, after breaking the connection which already exists there, of course. Such a modification would be advantageous if, with the aerial removed and the contrast control turned fully anti-clockwise, it is found that the raster is very dim and can be observed only in a darkened room.

The display of frame flyback lines is aggravated by (i) incorrect adjustment of the brightness control and (ii) the D.C. degeneration which, in common with certain other receivers, is applied to the video signal between the anode of the video output valve and tube cathode. D.C. degeneration is adopted mainly to reduce the effects of picture flutter resulting from passing aircraft, but in areas where this is not troublesome, it can be removed to advantage.

All that is necessary is to disconnect the resistor connected between cathode and grid of the picture tube, this being housed in the cover of the picture tube base connector, and to add a 68k resistor in series with the chassis lead of the brightness control to compensate for the change in the tube bias conditions.

The models mentioned above, along with certain other models of the Ferranti range, were designed originally for use with a TR14/2, 14in. rectangular picture tube. Although this tube had a 4V heater it was fed from a 6.3V winding on the mains

transformer of the receiver, the necessary voltage drop being accomplished by a wire-wound resistor connected in series with the tube heater circuit.

The TR14/2 is now obsolete, but a replacement tube which is suitable can be obtained from the original Ferranti company, via a dealer. This is known as Type TR14/8, and features a B12A base and a 6.3V heater; the other characteristics are similar to the TR14/2. Replacement thus necessitates a base connector change and the removal of the wire-wound heater resistor. The pin connections on the B12A base are as follows: 1 and 12 heater, 2 grid, and 11 cathode. There are no pins at positions 8 and 9 and no connections (or pins) at 3, 4, 5, 6, 7 and 10.

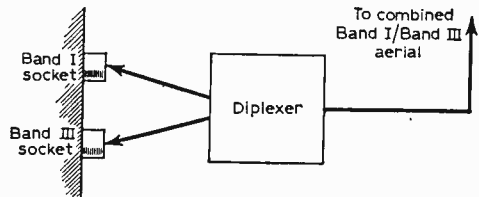

Fig. 22—One method of combining the inputs on Ferranti T5 and K5 models by using a good quality diplexer.

### Ferranti T5 and K5 Series

Sets of these series are fitted with separate 80Ω aerial input sockets for Bands I and III, but it often follows that low gain results by combining the aerials as detailed in the service data manual. Considerable improvement is possible either by combining the inputs through a good quality diplexer, as shown in Fig. 22, or by altering the input switching so that the "band-change" switch of the receiver functions also as an aerial change-over switch.

In the latter case, this is facilitated by a spare switch section on the "band-change" switch, and the modification should be carried out as follows: after removing the screen from the cabinet, extract the screen cover from the tuner. Next, transfer the lead on the tap of the Band III aerial coil (L5) from the lead-through insulator to the unused contact on the front section of the "band-switch," as shown in Fig 23. Finally, replace the tuner screen securely, refit the chassis into the cabinet and employ the original Band I aerial socket as the common input socket.

### Fringe Area Reception

In poor signal areas, the best performance is possible by using separate aerials for Bands I and III and feeding them individually through low-loss feeder to the appropriate sockets on the set (i.e., without combining). In areas where the Band III signal is weak, the performance can be further improved by disconnecting the existing wiring between the Band III aerial isolating capacitor and the tap on the Band III aerial coil (L5) and reconnecting it using a continuous length of good quality 70/80Ω feeder.

The modifications are as follows: unsolder and extract the lead from the tap on L5 to the lead-through insulator. Unsolder and remove the short length of coaxial cable which runs from the lead-through insulator to the Band III connections on

the aerial panel. Reconnect the aerial panel to the tap on L5 through a 15in. length of good quality coaxial cable, and route the new cable along the path taken by the original cable, through the hole in the chassis vacated by the lead-through capacitor—beneath the "band-change" switch assembly. Connect the new coaxial link at the other end to the tap on coil L5, with the centre conductor to the tap and the braid to an adjacent "earth" tag. Finally, retune the core in L5 for optimum Band III picture.

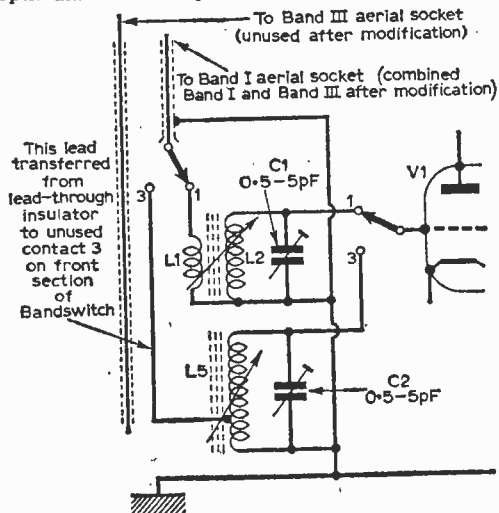

Fig. 23—How the aerial switching on Ferranti sets of the T5 and K5 series can be altered to provide a common Band I/Band III input.

**Tuner Units Type TU2**

These tuner units, which are contained in Ferranti Models T4 and K4, are available on the surplus market and are sometimes fitted to receivers of makes other than Ferranti. These differ from the more conventional type of tuner in that they have inputs for Band I at 70/80Ω and for Band III at 300Ω. As aerials designed for 300Ω feeder are

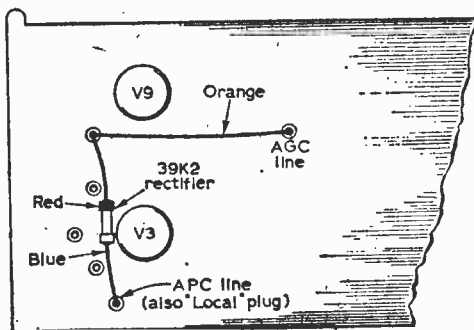

Fig. 24—How a type 39K2 Westinghouse metal rectifier may be connected on Ferranti models of the T4 and K4 series to avoid overdriving, which often results in picture inversion on changing channel if one signal is substantially stronger than the other.

rarely, if ever, available in this country, it is recommended that receivers using this type of tuner or the tuners themselves be modified for a combined input.

This can be accomplished fairly easily by linking together one of the Band III aerial input sockets (by selecting the socket giving the best results) and the spare socket adjacent to the Band I aerial socket.

On the projection receiver, Model 24K4, which uses this type of tuner, the coupling link must be fitted on to the front end tuner, which is accessible by lowering the front flat of the cabinet. The Band III connection (which is a flat 300Ω feeder) from the Band III aerial sockets at the rear of the cabinet to the corresponding sockets on the tuner is normally disconnected from the tuner proper, and can be left disconnected except in the unlikely eventuality of the Band III aerial being fitted with 300Ω feeder. In this event, the 300Ω feeder must be connected to the Band III aerial sockets on the tuner.

After connecting the link mentioned above, the 70/80Ω feeder from the combined aerial should be connected to the Band I socket of the receiver or tuner, and if separate aerials and feeders are in use, then these should be combined to a common cable by means of a good quality diplexer, as shown in Fig. 22.

In areas of poor signal strength, the combined input as detailed in the foregoing text can still be employed, but a 10pF ceramic capacitor should be used in place of the shorting link, and this should be connected between the unused Band III aerial socket (as before) and the earth terminal of the receiver. A further improvement may be possible on Band III by reversing the connections to the Band III aerial sockets. In the early days, Ferranti Ltd. produced suitable plug-type adaptors for this purpose, but it is unlikely that any are available at this time.

**Tuners Type TUI A.C./D.C. and TUI A.C. Only**

These tuners are similar to the TU2 series (e.g., with 80Ω input for Band I and 300Ω for Band III), and may also be available from time to time on the second-hand market. They can also be connected to a common feeder, but this time the shorting link is connected internally and permanently.

For improved Band III reception in fringe areas, the shorting link (which connects one side of the Band III aerial socket to the Band I input via a short length of twin feeder) can be removed from the tag panel and replaced by a 10pF ceramic capacitor. The other side of the Band III aerial input should be connected to the earth terminal of the receiver.

**Avoiding Over-Drive**

On T5 Ferranti models, a form of vision instability often occurred (and may still occur) on operation of the "band-change" switch when the signal on one channel was substantially greater than that on the other channel. This can result in a peak white raster or a negative picture which appears to be locked in spite of adjustment to the contrast control.

(Continued on page 486)

# A CATHODE RAY TUBE

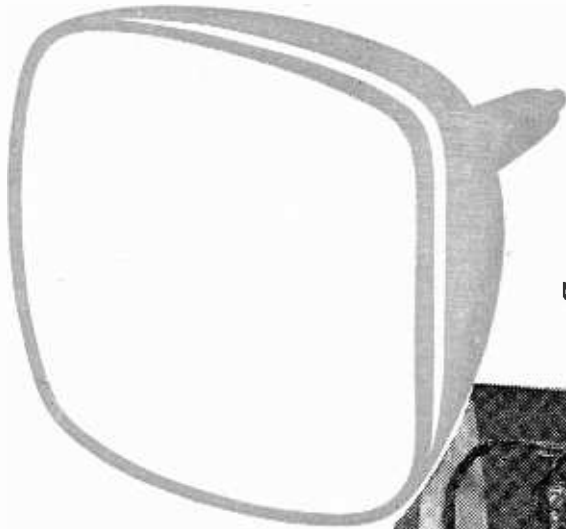

A QUICK-CHECK  
UNIT FOR MODERN  
PICTURE TUBES

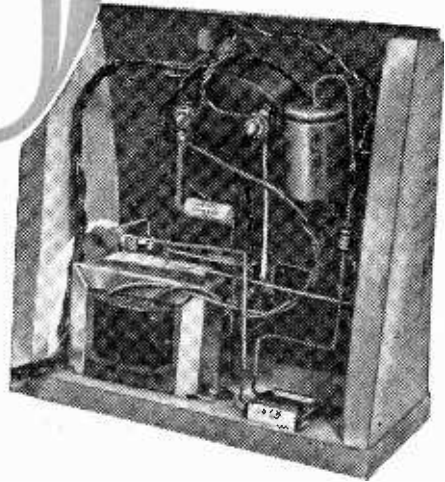

**T**HIS instrument tests C.R. tubes while they are in position in the receiver, and enables faults to be found and the effects of possible remedies determined. When designing the unit, it was decided that it should have the following features:—

1. Test for low emission, heater-to-cathode leakage, grid-to-cathode leakage, and low EHT.
2. Provision for boosting the heater voltage, firstly to check how much boost is needed to regain satisfactory emission, and secondly, to compare the picture with and without boost.
3. Provision for checking the effect of a low capacity isolation transformer on a tube with a heater-to-cathode leakage and for curing the usual type of grid-to-cathode leak.

Some of the above considerations tend to conflict with each other; for instance, if the EHT were to be measured directly, either a bulky valve voltmeter would have to be incorporated, or a delicate microammeter movement used, and so this test is carried out indirectly.

## Circuit

Since most tubes now use the 12-pin base with standardised connections and 6.3V heaters, the unit is built using a 12-pin plug (an old CRT base is suitable) and a 12-pin socket. If required, adaptors could be made for other tube bases and another transformer used with more voltage tappings.

The circuit of the test instrument is given in Fig. 2 and the plug and socket are wired up as shown with leads about 3ft long so that the instrument may be used while watching the picture on the CRT. The heater voltage for the CRT is selected by means of S1/S2/S3 and VR1, and its value is shown by the A.C. voltmeter M1. T1 is a low capacity 6.3V transformer with provision for 0, 25, and 50% boost to the heater voltage. In position 1 of S1/S2/S3, the heater of the tube is connected to its usual source of power (the heater chain in an A.C./D.C. set). In position 2 of S1/S2/S3, the heater is isolated from the set, but is not boosted, thus testing for heater-to-cathode leakage. In positions 3 and 4, 25% and 50% boost respectively are applied to the heater.

Switch S4 is a biased double-pole, change-over switch which is normally in the position shown in Fig. 2. C1 is charged to about 300V by the mains via MR1, but, on operating S4, the condenser is disconnected from the mains and connected between the grid and cathode of the tube. This puts a high positive bias on the CRT grid, which, if the EHT is at a workable level,

# TEST INSTRUMENT

By T. Sheldon

should cause a bright flash on the screen. On releasing S4, the tube should re-light after a few seconds, and C1 is left to be charged up through R1 ready for use again.

The circuit in Fig. 2 uses a transformer in which the primary is tapped to provide boosted heater voltages; an alternative circuit using a transformer with a tapped secondary is given in Fig. 4.

## Construction

The unit is constructed in a wooden case and the dimensions are given in Fig. 1. The wiring of the test instrument is shown in Fig. 3, and reference to this diagram and the illustrations will make the wiring easy to complete. The lay-out of the front panel is given in Fig. 5.

## Testing a Tube

The plug PL1 is connected to the tube-socket in the set and the socket SK1 to the tube-base in the set and the test instrument plugged into the mains, and the TV set switched on. With S1 in position 1, the set is allowed to warm up. The

2 side pieces, top panel and base are all  $\frac{1}{2}$ " softwood  
Front panel and back cover are  $\frac{1}{8}$ " hardboard

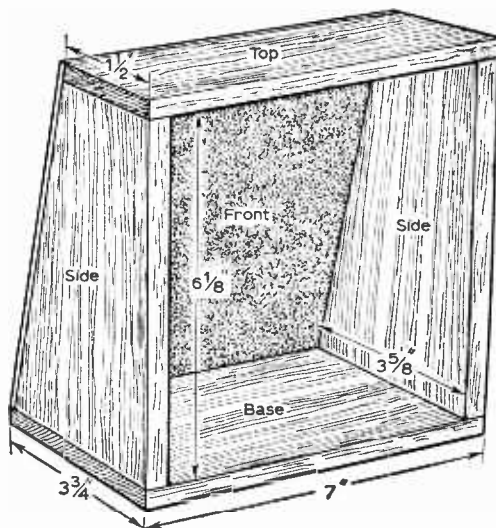
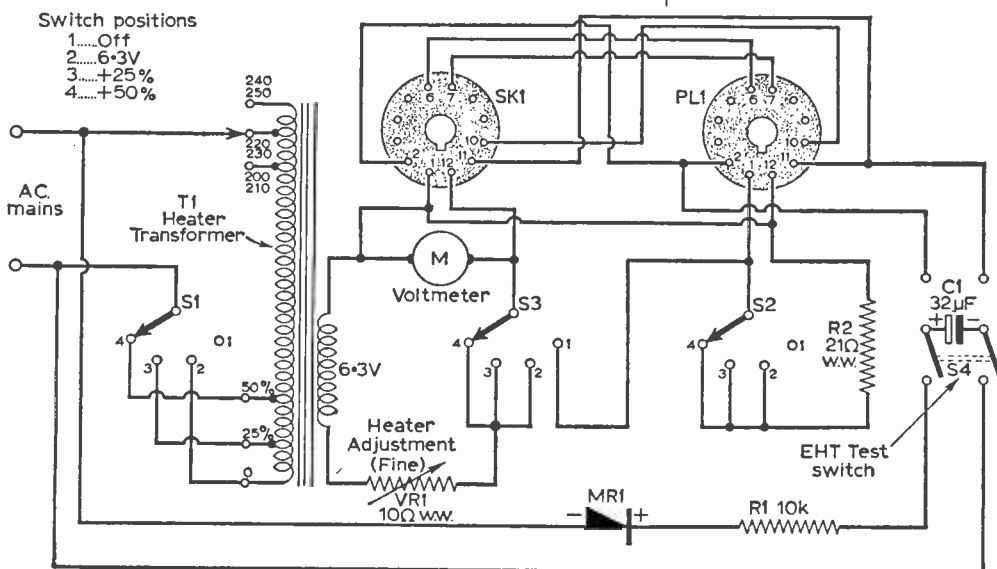
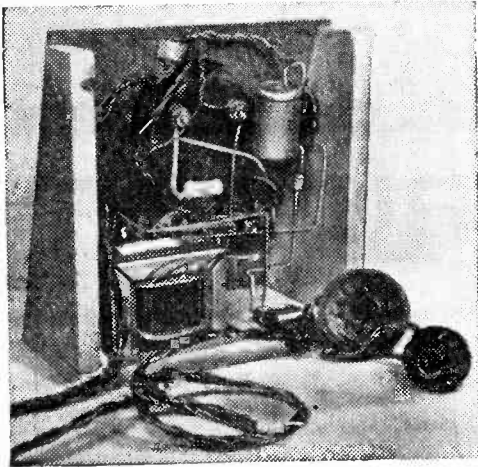

Fig. 1 (right)—The construction of the instrument.

Fig. 2 (below)—The circuit of the instrument using a mains transformer with a tapped primary.





(Above)—The completed instrument.

meter M now reads the heater voltage of the tube; if it is zero, either no power is reaching the set or the heater chain is open circuited. If the needle is hard over, the heater of the tube is open circuited, although this fault would normally be found during preliminary checks of the receiver. Slight errors in the heater voltage are of little consequence but could be caused by the use of the incorrect mains tapping on the set.

The switch S1/S2/S3 is now turned to position 2 and the heater voltage set to 6.3 with VR1. Should the picture now be normal, the tube has a heater-to-cathode leak, and a low capacity isolating transformer will be required to cure the fault. However, if the picture remains poor, S1/S2/S3 must be set to position 3 or even position 4, adjusting VR1 to give an acceptable picture. The voltmeter M then shows the voltage needed from a boost transformer.

If the picture is still not good, the cause is usually either low EHT, or a grid-to-cathode leak. If, on pressing S4, a bright flash is seen on the screen of the tube, the EHT is probably in order, and the fault may be a grid-to-cathode leak. These leaks are often caused by small pieces of conducting material lodging between the electrodes of the tube, and the sudden application of a high voltage pulse often burns them away. This pulse is provided by the charge in C1.

The whole process of using this CRT test instrument takes less than three minutes, and shows at once the effects of boosting and other processes without long delays and soldering of connections.

**Cabinet**

In order to make the instrument portable, it is as well to house it in a strong cabinet. The cabinet shown in the illustrations and in Fig. 1 was made from 1/4 in. softwood and 1/4 in. hardboard, the hardboard being used for the front panel and the back of the cabinet.

Construction of the cabinet should be begun by cutting out a piece of hardboard 7 in. square and marking it up for the actual components to be used in the instrument. The parts to be mounted on the front panel are indicated in Fig. 5. The meter will probably need a circular cut-out and a fret-saw or coping-saw should be employed for this operation.

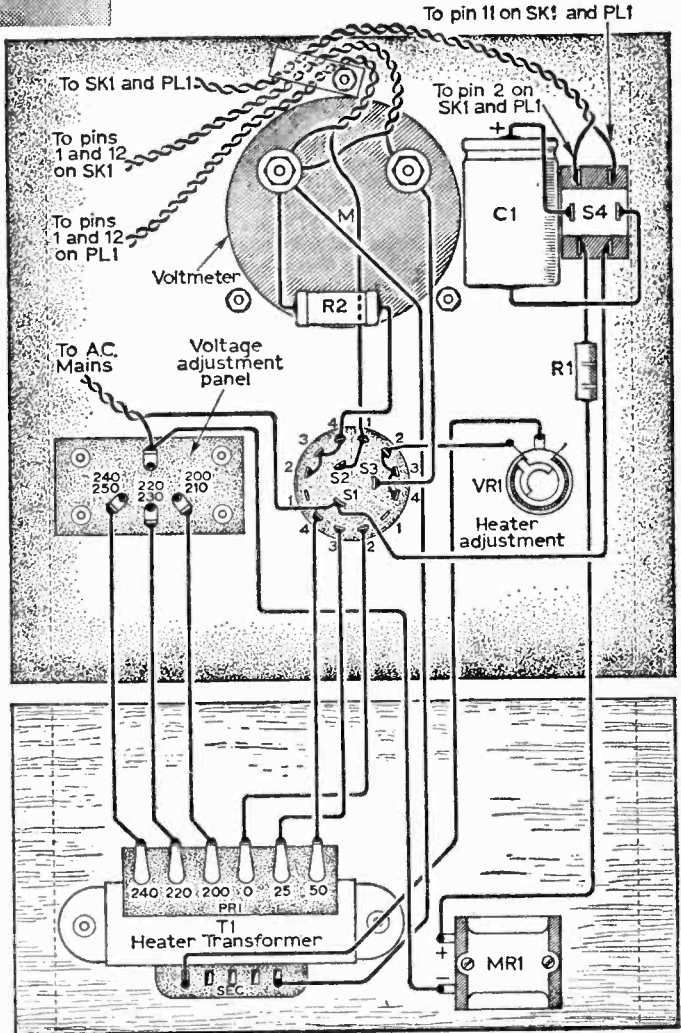

Fig. 3 (right)—The wiring diagram.

**Assembly**

The sides of the cabinet should be cut to the dimensions shown in Fig. 1 and if possible should be cut together so that they are both the same shape. The front edges of the base and top of the cabinet will need to be shaped to conform to the slope of the front panel.

Before assembling the cabinet, fit the necessary parts on to the front panel to ensure that they fit accurately. Then, remove them and use panel pins or screws to assemble the cabinet but do not fit the back, of

course. When all the hammering has been completed, then the meter and other parts may be fixed in position of the front panel.

The back of the panel should be screwed on so that it may readily be removed if any of the parts of the unit need to be replaced.

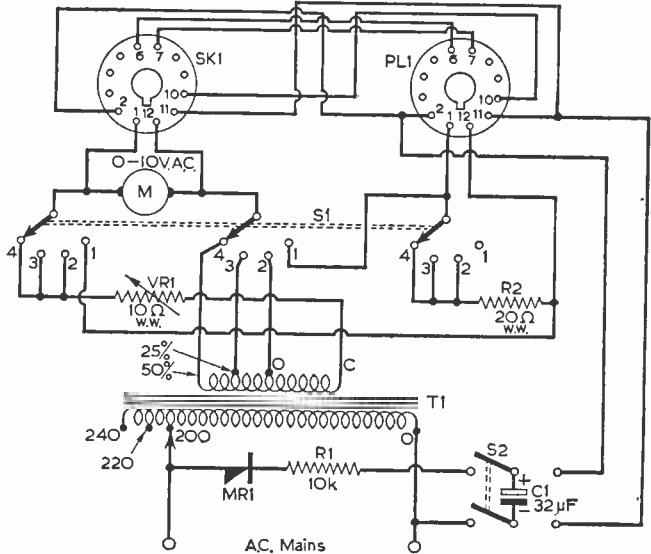
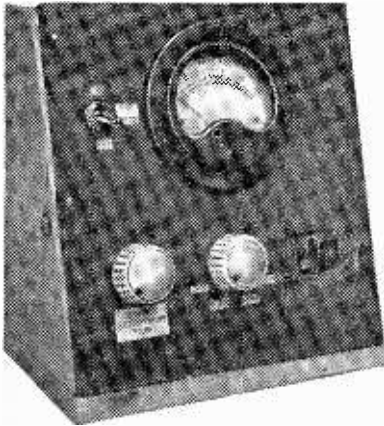

Fig. 4—An alternative circuit using a transformer with a tapped secondary.

**COMPONENTS LIST**

**Resistors:**

- R1 10k ½W
- R2 21Ω 3W wire-wound
- VR1 10Ω wire-wound potentiometer

**Capacitor:**

- C1 32μF 350V electrolytic

**Switches:**

- S1|S2|S3 3-pole, 4-way
- S4 biased double-pole, change-over

**Rectifier:**

- E250C50 or other small mains type.

**Transformer:**

- Low capacity CRT boost type (see text)

**Meter:**

- A.C. voltmeter—0-10V or 0-20V or similar

**Miscellaneous:**

- 12-pin CRT base and 12-pin socket; wire, solder, screws, wood for cabinet, etc.

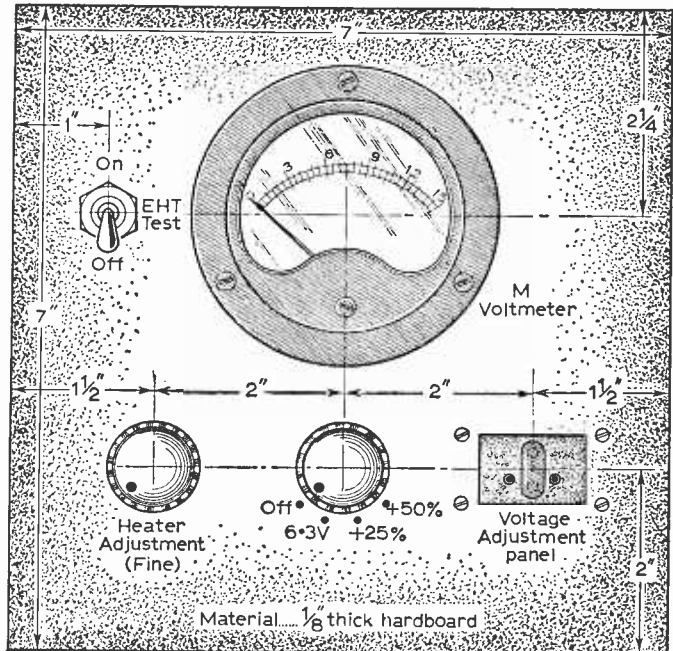

Fig. 5—The layout of the front panel.

# Signal and Feeder Problems Explained

By N. Baines

## NOISE AND REFLECTIONS

A TELEVISION picture can never be any better than the strength and quality of the signal fed to the receiver allow. Even if the set is a very expensive model and in perfect order beyond doubt, it cannot work correctly unless the signal present at the actual aerial socket is of a certain minimum level and free of distortion.

Poor pictures on sets which have no internal defects, therefore, are caused by two major factors: one, the signal strength being below the minimum necessary to provide a noise free picture (e.g., picture without grain or snow effect) and two, the signal being distorted either during its passage from the transmitting aerial to the receiving aerial or from the receiving aerial to the aerial socket of the receiver.

### What is the Minimum Signal Level?

It is extremely difficult to give an absolute value here, for much depends upon the design and age of the receiver and on the channel in use. Experiments have indicated that to completely mask the noise produced by a television receiver, the signal strength applied to the set must be 200 times greater than the noise signal.

At this stage, it should be explained that the signal amplifying stage of a television receiver itself produces a signal as the result of its amplification function. It is virtually impossible to amplify a signal without introducing noise. The noise which is produced is given an equivalent noise signal value in terms of microvolts ( $\mu\text{V}$ ), a typical value being  $5\mu\text{V}$ . In effect, this means that such a set operating without an aerial will be in receipt of  $5\mu\text{V}$  of noise signal, which shows up on the raster (screen illumination) as grain or a snow storm effect. Even when the aerial is plugged in, the noise signal will still exist, but, generally, the required signal will always be much greater than the noise signal.

Thus, to give our desirable 200 times ratio, the signal actually across the end of the coaxial feeder is required to be  $1,000\mu\text{V}$ . In practice, it has been discovered that the noise is barely visible at normal viewing distance if the ratio is only 100-to-1. This means that  $500\mu\text{V}$  would give a very good picture on a set of which the equivalent noise signal was  $5\mu\text{V}$ .

### Relation between Noise and Frequency

Unfortunately, the equivalent noise signal tends to become bigger as the channel number is increased, so, although it may be, say,  $5\mu\text{V}$  on Channel 1, it may rise to almost  $10\mu\text{V}$  on Channel

12 or 13. To keep the signal-to-noise ratio at 100-to-1, therefore, the aerial signal strength needs to be doubled to cancel the twofold rise in noise signal. For noise-free viewing we thus need  $500\mu\text{V}$  on Channel 1 and  $1,000\mu\text{V}$  on Channel 12. It is usually more difficult to secure a greater signal on Band III than on Band I, and this is the reason why thousands of sets are operating with far more noise on ITA than on BBC. Indeed, it is surprising how one can become accustomed to a very noisy picture.

The equivalent noise signal also tends to rise as the set ages which, of course, is directly responsible for a worsening of the signal-to-noise ratio. The trouble is made worse by progressive deterioration of the aerial and feeder, the sum total being that the noise goes up and the signal goes down.

The chief culprit so far as the set is concerned is the R.F. valve in the tuner. As the emission of this most important valve diminishes, so the noise figure of the set rises steeply. It pays, therefore, in those

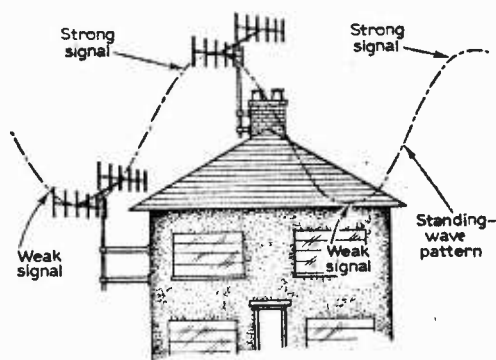

Fig. 1—A useful increase in signal pick-up is sometimes possible by moving the aerial from one position to another position on the house—this is due to the occurrence of standing waves.

cases where picture noise has progressively risen to make a check of the tuner R.F. valve, preferably by substitution. This valve is of the Mullard PCC84 or Mazda 30C1 variety—a double-triode in a cascade amplifier circuit. Noise can also be introduced by the frequency changer (the second valve in the tuner), and this should not be overlooked if the noise level is really high.

The noise performance differs between receivers. Modern sets with frame grid tuner valves produce an equivalent noise signal which is almost one half of that produced by their older counterparts, but



this must not be taken to mean that by simple substitution with a frame grid valve an old set can be given an improved noise figure. This is far from true. Noise can only be reduced by paying a great deal of attention to many small points, in addition to the use of frame grid valves. It could happen that the noise would increase by simple valve substitution.

The very early sets, notably those without multi-channel front ends, in some cases have a noise performance which is even worse than the early multi-channel models.

To summarise the points raised above, it may be said that to maintain the desirable 100-to-1 (which is the same as 40dB) signal-to-noise ratio, old models may require a signal two or, perhaps, three times stronger than the latest sets; also, that the signal applied to the set needs to be stronger on Band III channels than on Band I channels for a given signal-to-noise ratio, and this applies to any set.

The noise signal which produces the grain on a picture is mostly contributed by the first valve or stage in the set. This means, then, that if an add-on Band III converter is used, the noise performance on ITV will be a function of the noise generated by the first valve in the converter. Similarly, if the receiver is converted to multi-channel operation, the noise on all channels will be a function of the noise in the first valve in the tuner.

**How can the strength of the signal at the end of a download be checked?**

There is no simple way open to the experimenter to undertake the measurement of signal

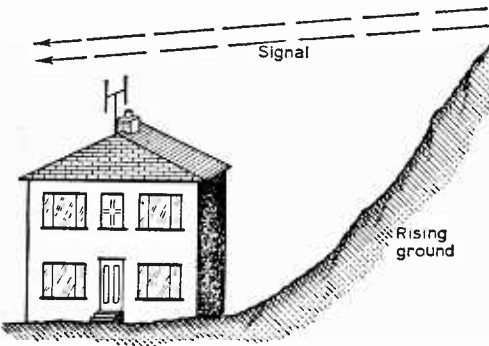

Fig. 2—Where the receiving site is shielded by rising ground between the aerial and the transmitter, it is well worth considering the possibility of mounting the aerial towards the top of the hill.

levels from the aerial. The signal voltage across the characteristic impedance of the download (about 75Ω) is in terms of millionths of one volt (e.g. μV). Even if an ordinary voltmeter were able to record such low voltages at very-high-frequency all the signals in the aerial would be measured at the same time, so this would not be much good.

What is needed is a signal strength meter. The input circuits of this instrument are rather like a multi-channel tuner, and so the required signal is

first selected. It is then passed on to other amplifying stages until it is of sufficient level to cause deflections of a valve voltmeter, the movement of which is calibrated direct in microvolts or millivolts (mV—thousandths of a volt).

Signal strength meters are available commercially in the price range of about £35 to £100. Most radio dealers are in possession of such an instrument, and are often prepared to measure aerial signals for a nominal fee.

**How can the Signal-to-Noise Ratio be Improved?**

We have already seen that there are two ways of increasing the signal-to-noise ratio. One is to step up the signal applied to the set, and the other is to step down the equivalent noise signal of the first stage. Let us take the aerial signal first.

A two-to-one increase in aerial signal is often possible simply by carefully turning the aerial for minimum noise. Modern sets have vision AGC, so an increase in signal pick-up will not normally produce a brighter picture, but it will most definitely reduce the grain and snow effect. This procedure needs two operators: one at the set and the other at the aerial. A field telephone is useful to enable the viewer to give immediate information to the operator turning the aerial as to the picture conditions and when the noise is at a minimum.

The best idea, of course, is to use a battery-operated signal strength meter arranged so that any signal variation can actually be observed by the operator turning the aerial. It is sometimes possible to borrow an instrument!

**New Download**

A further increase in signal conveyed to the set is invariably achieved by replacing the coaxial download. After several years of exposure to a diversity of weather conditions, coaxial cable tends to increase in attenuation. It also pays to have the aerial down and give it a good clean, particularly around the dipole insulator.

Where noise has been troublesome, a good quality, low-loss cable should be used as a replacement download. Table I gives some typical attenuation values of modern downloads. It will be seen that the semi-air-spaced variety with an inner conductor of 0.048in. diameter has much to commend it. This has less than half the loss of a solid polythene coaxial cable containing an inner conductor made up of seven strands of 0.00076in. diameter

Cable Type	Dielectric and Inner Conductor	Attenuation dB/100ft.		
		at 45Mc/s	at 100Mc/s	at 200Mc/s
1	Solid polythene 7/0.0076in.	3.1	4.7	6.9
2	Cellular polythene 7/0.010in.	2.5	3.6	5.3
3	Cellular polythene 1/0.044in.	1.4	2.2	3.3
4	Semi-air-spaced 1/0.048in.	1.5	2.2	3.1

conductors. Generally speaking, although slightly more flexible, a cable made up of multi-strands for the inner conductor has slightly higher losses than a comparable cable with a plain copper wire inner conductor.

It will be seen, therefore, that by changing from, say, cable type 1 to cable type 4, an improvement of nearly 4dB is possible over a run of 100ft.

Let us consider some actual figures. Suppose, for example, that the aerial has across its dipole terminals  $500\mu\text{V}$  of signal. By running it through 100ft of type 1 cable, the signal at the set would be approximately  $230\mu\text{V}$ , but by running it through type 4 cable, the set signal would be about  $360\mu\text{V}$ . These figures apply, of course, to the Band III channels, for the Table shows that the loss increases with increase in frequency. An interesting point is also revealed for the semi-air-spaced cable in that although the loss is less at 200Mc/s in relation to type 3, for example, the loss is a little greater at 45Mc/s.

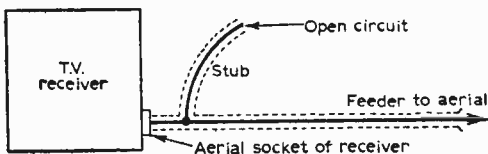

Fig. 3—An open-circuit stub can be used to cancel reflections in the download. The stub should be connected in parallel with the download and it has a critical length—see text.

### Moving the Aerial

If it is still impossible to achieve a substantial rise in the signal reaching the set by attending to the aerial and feeder, then it may well be necessary to probe with the aerial for improved pick-up. If there are standing waves in the vicinity, resulting from random reflections and impedance changes, simply moving the aerial from one position to another could produce a useful increase in signal pick-up, as illustrated by Fig. 1.

If the receiving site is screened by rising ground in the direction of the transmitter, as shown in Fig. 2, the possibility of mounting the aerial at the top of the hill should be explored. The use of an aerial pre-amplifier would be desirable in this case.

It is always best to endeavour to improve the signal-to-noise ratio by stepping up the aerial signal, but when everything possible has been done in this direction, reducing the first stage equivalent noise signal is sometimes possible. It is not generally a simple matter to improve on the noise figure produced by the design. The use of a new tuner using frame grid valves is one way out, though an expensive one.

There is another way, however, and that is to use a low-noise pre-amplifier. This will step up the limited signal while only introducing just a little noise signal, and the signal applied to the actual set will then be of a level which should far outweigh the noise signal there. Various designs for low-noise pre-amplifiers have already been given, and the low thermal noise of transistors makes them well worth considering. There is, at least, one commercially produced low-noise transistor aerial

amplifier (*Belling and Lee Limited*) using a single transistor and giving a gain of around 14dB.

### What about Signal Distortion?

Signal distortion is produced in two main ways; one due to multiple reflections, the aerial receives more than the direct signal. It also receives signals reflected from nearby objects.

Ghosting and its associated effects can often be minimised by the use of broad-side aerial arrays. Such arrays have high gain and as a consequence are highly directional. It is thus possible to orientate the array for the least ghosting consistent with adequate signal pick-up. There are no hard and fast rules here, it usually being a question of experimentation, but one *must* start with a good, highly directional aerial.

The signal can also be distorted during its journey in the download. If there is a very bad mismatch, which could result from the use of the incorrect feeder for the receiver, especially if the feeder is extra long, signal reflections occur up and down the cable (rather like reflections between two mirrors). The reflected signals again interact with the direct signal and, although the delay may not produce an actual ghost, the signal as applied to the set can, nevertheless, be distorted. This can cause poor horizontal definition, more-than-normal interference and can even produce a bright vertical line on the left of the picture. If the latter can be varied by altering the position of the download at the back of the set, mismatch is the cause. A more stable and low-loss feeder goes a long way towards clearing this sort of trouble.

Feeder reflections can often be cancelled by connecting a small length of feeder in parallel with the download of the aerial concerned. This is called a coaxial stub and it has a critical length depending upon the channel. The end of the stub should be open-circuit and for Band I it should have a length of about 6ft, and for Band III about 20in. It should be cut down a little at a time until the best picture is produced. If too much is cut off, then the picture will quickly start to deteriorate again. The idea is given in Fig. 3. ■

## SERVICING DATA AND MODIFICATIONS

(Continued from page 479)

This can be cured without a great deal of trouble, however, by the inclusion of a Westinghouse Type 39K2 rectifier in the sound AGC line and the vision APC line, as shown in Fig. 24. The rectifier can easily be fitted to the top deck of the IF amplifier strip, and for this operation it is not necessary to remove the chassis from the cabinet. The red side of the rectifier should be connected to the sound AGC line and the blue side to the vision APC line.

On models of the T4 and K4 series, a similar modification is available, but here the red (cathode) side of the rectifier should be connected to the junction of R36 and the lead-through insulator between trimmers L123 and L127, while the blue side should be connected to the junction of the green APC leads on the I.F. deck tag panel.

This modification is not required on sets of the T3 and K3 series which incorporate tuner units Type TU2, as these models feature manual gain control and have no APC.

(To be continued)

# How TV Remote Control Works

THE VARIOUS ARRANGEMENTS USED BY MANUFACTURERS IN PROVIDING THIS LATEST FACILITY ON THEIR SETS

By J. Jones

**M**ANY recent television receivers feature either a remote control unit or facilities for fitting such a unit should this be required later by the viewer. There are several rather clever arrangements for providing remote control on both sound and vision as this article reveals, and since some of the circuits differ substantially from ordinary TV circuit practice, it is essential to secure, at least, a basic understanding of how they work so that satisfactory repairs and adjustments can be made.

Remote control started life as an extension of automatic control. Auto-control in this context simply means that a small electric motor is mechanically

in some tuners a muting action is also available which, in effect, reduces the sensitivity of the receiver while the tuner is passing through those channels between that tuned and that selected. One big advantage of auto-tuners is that the tuner unit proper may be mounted almost anywhere in the receiver since the control is effected through push-buttons and not mechanical linkages.

There are several different arrangements for switching power to the tuner motor and for muting the receiver at intermediate channels, but the basic idea is shown in Fig. 1 and is used in the Pye Auto Models. When the tuner is stationary at the channel to which the tuner is set, S2A is open and S2B is closed. These switches are operated mechanically by the tuner and the former applies mains power to the motor while the latter applies H.T. voltage to the tuner and I.F. stages. In the quiescent state, therefore, the motor is stationary and H.T. is applied to the tuner and I.F. stages.

When the channel-change button, S3, is depressed, power is applied to the motor from the mains supply circuit and the tuner turns. As soon as this happens, S2A closes and switches power to the motor, thereby allowing S3 to be released. S2B opens and mutes the receiver while the channel-changing operating is occurring.

These conditions exist until the tuner reaches the channel position which has previously been pre-set. At that point, S2A opens to stop the motor and S2B closes to restore H.T. to the tuner and I.F. stages.

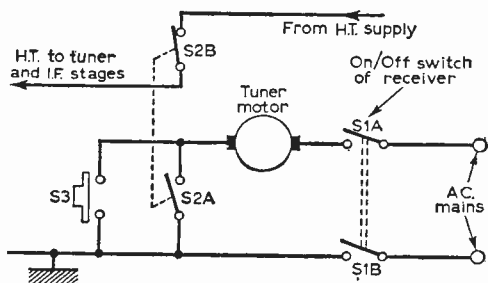

Fig. 1—The basic circuit for auto-tuning. The tuner motor is energised from the mains supply when button S3 is depressed. Switch S2A closes when the motor operates and opens again at the pre-set stop. Switch S2B mutes the receiver when the tuner is passing intermediate channels.

coupled to the tuner to take the hard work out of channel changing. Thus, instead of the viewer having to impart considerable pressure to the channel selector knob to change from one programme to another, the motor does all the hard work and all the viewer has to do is to press a button corresponding to the required channel. This is rather similar to the electric typewriter in which an electric motor operates the typebars, and all the typist has to do is to press very light-action buttons or keys to make the appropriate contact.

## Auto-tuners

Auto- or "motorised" tuners are electrically equivalent to their manual counterparts, but instead of the turret or switch assembly being operated by a control knob, a mains-operated induction motor drives the turret or switch through a clutch and step-down gear chain. An induction motor avoids interference on channel changing and

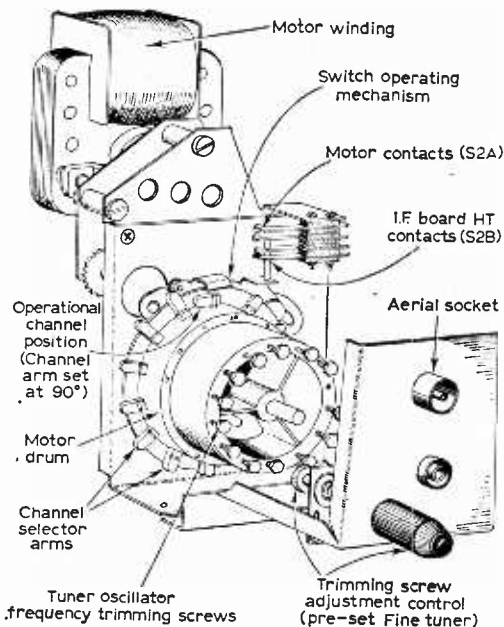

Fig. 2—The mechanics of the Auto Tuner used in Pye receivers.

**Operation**

The mechanical functions involved are revealed in Fig. 2. The motor drum carries channel selector arms (one for each channel) which can be turned through 90°. To pre-set for any channel, it is necessary simply to turn the appropriate selector arm so that it is flat with the face of the drum. Thus, when the motor starts turning, the channel selector arms which are vertical lift the mechanism which operates switches S2A and S2B, thereby providing the action already described.

The switch mechanism remains in the "lifted" position until the motor drum arrives at a point where a channel selector arm is flat with the face of the drum (at the point shown on the diagram). There is then nothing to hold the switch in the "lifted" position, so the contacts change over, the motor stops and H.T. is restored. A "click" mechanism ensures that the tuner is correctly indexed on the selected channel.

Individual oscillator trimming screws allow each channel to be adjusted accurately in the first place to avoid fine tuning each time a channel is changed.

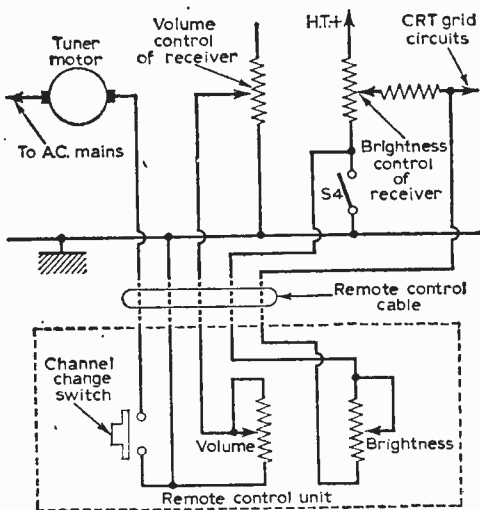
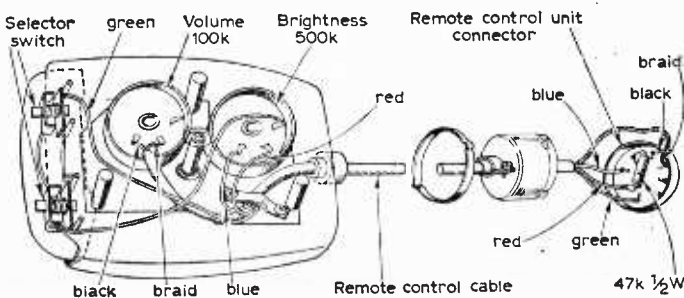

Fig. 3 (above)—A remote control circuit and interconnections.

Fig. 4 (below)—The remote control unit of the Pye Auto Series receivers.



To facilitate this a trimming adjuster is provided on the rear of the assembly, as shown. This is spring-loaded and, when pushed in, engages on the head of the appropriate trimming screw.

**Remote Control**

It may now be realised how simply a remote control can be connected to an auto system of this kind. Indeed, it is necessary only to extend the

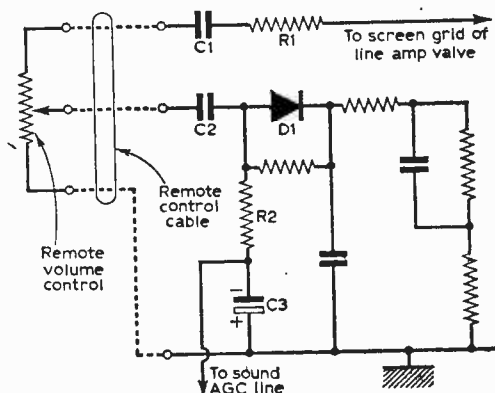

Fig. 5—Remote control of volume is sometimes more complicated than simple paralleled controls. This circuit shows the method used in Philips models.

channel change press-button by cable to provide remote channel-changing.

Such a facility is available on the Pye Auto series and also on other sets of similar design. There are also extended volume and brightness controls, thereby giving almost complete control of the receiver from a remote point. The circuit in Fig. 3 shows the general remote control arrangements. In effect, both the volume and brightness controls are connected in parallel with their counterparts in the receiver proper, and a separate channel-change button connects the motor to the mains circuit remotely. The various connections and the construction of the Pye remote unit are given in Fig. 4.

In the Philips Auto models, the remote control works in conjunction with the sound AGC line from rectified pulses picked up from the line amplifier valve, as shown in Fig 5. Here, line pulses from the screen of the line amplifier are applied across the remote control through R1 and C1. The pulses, at the required amplitude, are tapped from the slider of the control and applied through C2 to the anode of diode D1. This causes C3 to charge negative with respect to chassis through R2 due to the normal rectification action. Thus, depending upon the setting of the remote volume control, so a negative voltage is reflected on to the AGC line, which reduces the stage gain and hence the volume accordingly.

(To be continued)

VACUUM  
ELECTRONIC  
LIMITED

# KEEPS YOU IN THE PICTURE

WITH THE  
FINEST REBUILT CATHODE RAY TUBES

12 MONTHS  
GUARANTEE

12"-14" £4-15-0	<b>15/-</b>	ALLOWED ON RECEIPT OF OLD TUBE
15"-17" £5-5-0		
21" £7-15-0		

CASH WITH ORDER OR  
PRO FORMA, ADD 12/6 FOR  
CARRIAGE AND INSURANCE.

DELIVERY FREE IN LONDON AREA

WRITE PHONE OR CALL  
**VACUUM ELECTRONIC LTD.**  
35, SACKVILLE STREET  
LONDON, W.1  
REGENT 6404

Own one of these cars below?  
Then save yourself £££'s ...

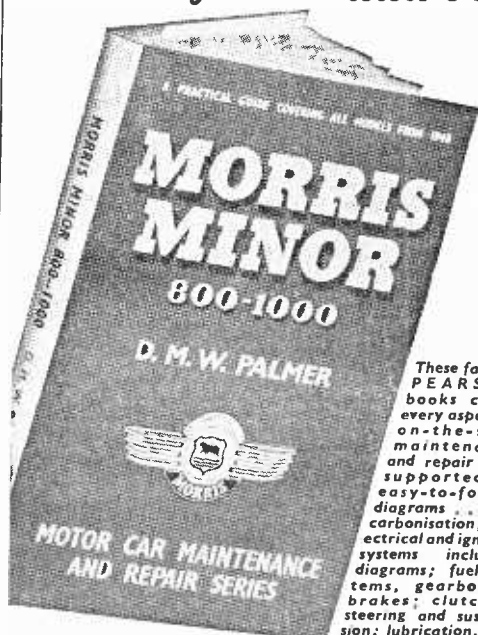

These famous PEARSON books cover every aspect of on-the-spot maintenance and repair fully supported by easy-to-follow diagrams ... decarbonisation; electrical and ignition systems including diagrams; fuel systems, gearboxes; brakes; clutches; steering and suspension; lubrication, etc.

- AUSTIN CARS** by T. B. D. Service. Models from 1932 to 1960. 137 illustrations.
- AUSTIN-HEALEY CARS** by C. P. Davidson. Models from 1952 to 1960. 95 illustrations.
- AUSTIN MINI & MORRIS MINI-MINOR** by Arthur George. Models from 1959. Over 100 illustrations.
- FORD ANGLIA, PREFECT, POPULAR, 8 & 10 h.p. CARS.** Models from 1934 to 1961. 117 illustrations.
- FORD CONSUL, ZEPHYR, ZODIAC and V.8 CARS.** Models from 1935 to early 1961. 130 illustrations.
- HILLMAN CARS** by Stephen J. Maddock and J. Earney. Models from 1936 to early 1961. 122 diagrams.
- HUMBER CARS** by C. J. Beddall-Smith. Models from 1946 to 1961. 116 illustrations.
- JAGUAR CARS** by C. L. Vandiest. Models from 1946 to early 1961. 183 illustrations.
- LANDROVER** by V. H. Watson. Models from 1948 to 1961. 94 illustrations.
- M.G. CARS** by C. P. Davidson. Models from 1934 to 1960. 118 illustrations.
- MORRIS CARS** by T. B. D. Service. Models from 1934 to 1960. 112 illustrations.
- MORRIS-MINOR 800-1000** by D. M. W. Palmer. Models from 1948. 100 illustrations.
- RILEY CARS** by S. F. Drake. Models from 1936 to early 1957. 82 illustrations.
- ROVER CARS** by V. H. Watson. Models from 1934 to 1957. 79 illustrations.
- STANDARD CARS** by T. P. Postlethwaite and I. Walton. Models from 1936 to early 1957. 118 illustrations.
- TRIUMPH CARS** by T. P. Postlethwaite. Models from 1937 to 1958. 106 illustrations.
- TRIUMPH HERALD CARS** by T. P. Postlethwaite. All 948 c.c. and 1200 models. 110 illustrations.
- VAUXHALL CARS** by F. A. Stepany Acres, M.I.Mech.E. Models from 1933 to 1960. 116 illustrations.
- VOLKSWAGEN** by Raymond Broad. Models from 1947 to 1960. 72 illustrations.
- WOLSELEY CARS** by D. V. W. Francis. Models from 1936 to 1959. 127 illustrations.

Only 12s. 6d. each  
FROM ALL BOOKSELLERS

... or in case of difficulty 13s. 6d. by post from  
C. ARTHUR PEARSON LTD., Tower House,  
Southampton St., London, W.C.2.

PEARSON

## DUKE & Co. (London) Ltd.

621/3 ROMFORD RD.  
MANOR PARK E12  
ILFord 6001/3

Stomp for latest Free List.

17 inch £11.10.0

14 inch £7.10.0



- ★ Guaranteed 12 months.
- ★ Ex-Rental and repossessed Televisions.
- ★ Any two selected channels (or more extra).
- ★ H.P. Terms London area.
- ★ Legs 39/6 per set extra.
- ★ Demonstrations daily.
- ★ Part exchange allowance on Radios, T.V.'s, etc.

Personal collection advised, special delivery by arrangement, B.R.S. Ins., Carr. 30/- (London area).

## REBUILT TUBES

Guaranteed  
ONE  
YEAR



21 in. 99/6

17 in. 90/-

15, 14 and  
12 in. 70/-

TERMS:

Add £1, refundable on receipt of your OLD tube.  
Ins., Carr. 12/6.

**35/-** EX RENTAL REPLACEMENTS

14 in. = 36/24 and 14KP4  
also few odd types and sizes, please enquire.  
Carriage 5/-

# D. & B. TELEVISION

Phone: Cherrywood 3955

Dept. B5

131 & 131a KINGSTON ROAD, South Wimbledon, London, S.W.19

"Compare our prices with any others"

For more Transistors and Components see our advertisement in "Practical Wireless" For the **FINEST, FASTEST SERVICE** in the COUNTRY. We are open from 10 a.m. Until 7 p.m. (1 p.m. Wednesday) For any information or problems you have. Call or Phone, we are always pleased to help. We pride ourselves that we can obtain and supply any TV spare, **OUR GIGANTIC STOCKS INCLUDE:** Line, Frame and Sound Output, Line and Frame Blocking Osc., Trans., and Scan Coils for any make or model Television.

## LINE OUTPUT TRANSFORMERS (P. & P. 3/6)

ACE, ASTRA 57/3, ALBA, T301, T304, T394, T484, T494, TR1974, 42/6.  
AMBASSADOR, MOST MODELS AVAILABLE ARGOSY, CTV5, 66/9.  
ARMSTRONG, T.V. 5/14, T.V. 5/17, 57/9. BAIRD, 2014 to 2217, 57/9.  
BANNER, MOST MODELS AVAILABLE. BEETHOVEN, B94 to B99, 57/9.  
BUSH, TUG26, TV32, TV33 to TV43, 87/-.  
COLUMBIA, C501L to C502, 69/-.  
CHAMPION REWIND ONLY.  
COSSOR, R17A, 930, 931, 933, to 944, 946, 50/6.

DECCA, DM1, DM2C, DM3, DM4C, DM5, 72/6. ALSO USED.  
DEFIANT, SOME AVAILABLE. SOME REWIND ONLY.  
DYNATRON, AVAILABLE, BUT SAMPLE L.O.P.T. REQUIRED.  
EKCO, TC208, TU209, T231, T248, T267, T284, T293, 57/6.

### MOST MODELS AVAILABLE

ENGLISH ELECTRIC, REWIND ONLY. EMERSON 701, 700, 704, 57/9.  
FERGUSON, 103T, 105T, 113T, 145T 64/6. 203T, 246T. INCLUSIVE, 64/6. 992 to 996, INCLUSIVE, 64/6. 306T, 308T, 62/-.  
FERRANTI, 14T3, 17K3, 17T3, 45/-.  
FULLOTONE, 12in., 14in., 57/9.  
G.E.C., BT1251, BT1252, BT1746, BT1748, 46/-.  
H.M.V. 1824 to 1831, INCLUSIVE, 64/-, 3851 to 5902B, INCLUSIVE, 94/3.  
INVICTA, T101 to T104B, 44/-, T118, T119, T120, 52/6.  
K.B., LFT50, LVT50, LFT60, MV60, 105/-.  
MARCONI, VT58DA, VT59DA, VC60 VT61DA, 57/9.  
MASTERADIO, TE7C, TE7T, TE7, TG7C, TG7T, TE21C, 57/9.  
MCMICHAEL, TM54F, C417MF, TM417F, 57/9.  
MURPHY, V214, V240, V250, V270, V280, 68/6. ALL MURPHY SPARES AVAILABLE.

PAM, 908, 909, 952, 953, 958, 52/6.  
PETO SCOTT, TV91, TV92, TV121, TV122, 48/3. PHILCO, 1707, 1708, 48/3.  
PHILIPS, 1114UF, 1115U, 1446U, 72/6. MOST MODELS AVAILABLE, ALSO USED.

PILOT. ALL MODELS CAN BE REWOUND.  
PORTADYNE, TC12 69/-.  
PYE, VT4, V4, V7, VT7, 52/6. MOST MODELS AVAILABLE, ALSO USED, at 32/6.  
REGENTONE, 12B1G, 12T15, 69/-.  
R.G.D., C55, 1455, 1456, 1755, 1757, 90/-.  
SOBELL, T21, T21C, T22, 74/-.  
STELLA, ST5721U, ST8617U 96/-.  
ULTRA, MOST MODELS AVAILABLE. VIDOR, MOST MODELS AVAILABLE.

WESTMINSTER, T1455, 69/-.  
WHITE IBBOTSON, MOST MODELS AVAILABLE.

## T.V. TUBES

ALL TUBES ARE REGUNNED WITH FULL 12 MONTHS' GUARANTEE.  
12in. MULLARD TYPE..... £3.15.0 12in. MAZDA TYPE..... £3.15.0  
14in. MULLARD TYPE..... £4. 5.0 14in. MAZDA TYPE..... £4. 5.0  
15in. MAZDA TYPE..... £4. 5.0 16in. G.E.C. TYPE..... £4.15.0  
16in. MULLARD TYPE..... £4.15.0 17in. MULLARD TYPE..... £4.15.0  
17in. MAZDA TYPE..... £4.15.0 17in. G.E.C. TYPE..... £4.15.0  
17in. BRIMAR TYPE..... £4.15.0.

90° AND 110° TUBES ON EXCHANGE BASIS ONLY  
ADD 5/- FOR ELECTROSTATIC TUBES, ADD 10/- FOR 90° AND 110° TUBES.  
CARR. AND INS. C.W.O. OR C.O.D.

### ALL VALVES ARE SOLD SUBJECT TO FULL GUARANTEE—CURRENT VALVE LIST

AZ31	8/6	BBF80	7/6	EL38	12/-	PCP86	8/6	U25	12/-	UC138	18/6	CU2	3/-	12AT7	4/6
B36	8/6	BBF89	8/6	EL41	7/6	PCL82	7/-	U38	9/6	UF42	2/6	GF1	4/6	12AX7	5/6
D77	8/-	CC81	4/6	EL64	6/6	PCL84	9/6	U51	7/-	U41	7/-	GF12	3/-	12AU6	6/6
DA91	5/-	CC82	5/6	EM80	3/6	PCL84	7/6	U37	17/-	UL44	10/9	GF18	6/6	20D1	8/6
DA96	7/-	CC83	6/6	EM84	9/6	PCL86	10/-	U59	0/6	UL46	7/-	GF14	8/6	20P2	8/6
DF91	3/6	CC84	7/6	EY61	7/6	PL33	8/-	U82	7/-	UL84	7/6	GF15	9/6	20L1	12/6
DF96	7/6	CC85	7/6	EY80	7/6	PL36	9/6	U131	8/6	U8	14/6	GF38	6/6	20P1	9/6
DH63	6/-	CCP80	8/-	EZ40	6/6	PL38	14/6	U281	9/-	U88	0/6	GF11	12/6	20P3	12/-
DH77	4/6	CC121	15/-	EZ41	6/6	PL41	8/6	U282	14/6	UY9	9/6	GF11	12/6	20P5	14/6
DK91	6/-	CC135	8/-	EZ50	6/6	PL42	6/6	U301	17/6	UY41	6/-	GF8	6/6	20P6	14/6
DK93	7/6	CC142	7/6	GZ32	8/6	PL43	8/6	U80	22/-	UY85	0/6	GF18	8/6	20P4	14/6
DK96	7/6	CC181	7/6	GZ34	12/6	PL44	8/6	UAC80	8/6	W77	4/6	GF19	12/6	27B5	14/6
DL81	8/6	CC180	7/6	KT38C	6/-	PY31	6/-	EY31	7/-	UF42	8/6	Z77	3/6	80C1	7/6
DL82	6/6	CC182	9/6	KT36	8/6	PY32	10/-	UB41	7/6	U14	4/6	8V8	4/6	30FL1	9/6
DL84	7/-	CC183	11/6	KT61	8/6	PY80	8/-	UB41	7/6	514	8/6	8V8	10/-	30L1	7/6
DL96	7/-	EF80	4/6	KT63	6/6	PY81	6/-	UBF89	7/6	5Y3	6/6	10P1	4/6	30P4	11/6
EABC80	7/6	EF85	6/6	KTW61	5/6	PY82	6/-	UC84	12/6	6Z4	10/-	10C1	10/-	80P12	8/6
EF42	7/6	EF86	8/6	KTW63	5/6	PY83	8/-	UC95	7/6	6AL5	3/-	10C2	13/6	82K10	10/-
EF41	6/6	EF89	6/6	PC84	7/6	PY85	12/-	UCF80	14/6	6AM6	3/6	10P13	8/6	53K10	10/-
EF91	3/-	EF91	3/-	PC88	8/6	PZ80	8/-	UCH21	12/3	6AT6	5/6	10P14	8/6	54K10	8/6
EF93	4/6	EF92	4/6	PCP80	7/6	U22	6/6	UCH42	7/-	6AT6	5/6	10P14	8/6	54K10	8/6
ER04	7/6	EL38	7/6	PCP82	8/6	U24	10/-	UCH81	8/6	6BW6	7/6	12AT6	7/6	12BT6	14/6

These are only examples of our valves: if you do not see what you require send stamped addressed envelope for special quotation.

Please ask us for ANY components you may require we are almost certain to have them. TERMS: S.A.E. all enquiries. C.W.O. or C.O.D. 3/- extra. Postage on Valves, 6d. each. C.R.T.s 12/6 inc. insurance. SATISFACTION ASSURED. RETURN POST SERVICE.

# NOW ANYONE CAN AFFORD TO TRAIN TO BE AN EXPERT IN RADIO and ELECTRONICS

## EVEN QUALIFY FOR A CERTIFICATE

It's the most exciting news of the year! Just imagine. You can get 35 large, fact-packed lessons or little more than 1/- per lesson! The lessons are crystal clear, practical, easy to master and use. Early lessons make fundamentals clear even to the beginner. While other lessons will give you the practical "know-how" of an expert.

Compare favourably with some courses costing ten times as much. You save because you receive all the lessons at one time and are not required to purchase equipment you do not need.

This is a real home-study course that has been bound into one giant 8 x 11in. 216 page manual. Each page is divided into two columns. A wide column features the text, while a narrow column at the side has the instructor's comments, helpful suggestions and additional pictures to simplify the difficult parts.

Everyone can benefit from this practical course. No old fashioned (or pseudo modern) methods used here, just straight forward, easy to understand explanations to help you make more money in electronics.

As an optional extra, you can pay a further fee if you wish to complete the questions set at the end of each lesson and have an expert check your answers. Students who attain a minimum of 40% correct answers can qualify for a certificate of proficiency in basic radio and electronics. Details sent with each course ordered.

You must be convinced that this is the best value you have ever seen in electronic training, otherwise you can return the manual (or have your money refunded if sent with order) after you have examined it in your own home for a period of seven days. The price! Only 86/-, plus postage.

# FREE TRIAL OFFER!

To start TECH TECHNICAL BOOKS, Dept. T.C.G. Gater's Mill, West End, Southampton. Hants.

- RUSH! Radio and Electronics Course for seven days examination. If I keep the course I can either pay 37/6d. cash or 12/6d. deposit after seven days and two payments of 12/6d. monthly. Otherwise I will return the course post-paid and owe nothing.
- SAVE! Send only 36/- if paying cash with order. (We pay postage). Same 7-day money-back guarantee.

Name \_\_\_\_\_  
Address \_\_\_\_\_

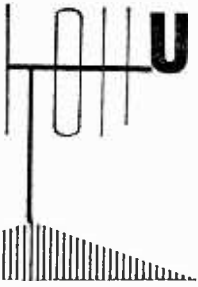

# UNDERNEATH THE DIPOLE

A MONTHLY  
COMMENTARY



BY ICONOS

**D**O you view with the room lights full up, half up or not on at all? Picture quality varies a lot in accordance with the general lighting in a room and, of course, some adjustment is necessary to the brightness or contrast controls (or both) when the ambient lighting is changed. That is unless the set has some kind of automatic device such as that recently described (May issue, page 374) in which a light sensitive cell and associated circuitry makes the necessary adjustment for you. There are certain commercial receivers now on the market which include similar automatic devices. It is a very worthwhile refinement which will be of even greater importance when colour TV is in operation.

## Colour—and Stray Light

Colour television suddenly seems to be a practical proposition from all the reports and rumours which are trickling around the "grapevines" of the television industry. It will be a good move for the use of the ambient light set brightness control to be a familiar piece of circuitry as soon as possible, because nothing kills colour TV more effectively than strong room lighting—and the actual colour of that lighting has to be watched, too. Lights which have red or amber shades tend to give the picture a bluish tone. Some kind of room lighting is essential not only to enable you to find your way about but to prevent eyestrain. Modern aluminised tube phosphors can give brilliant pictures of which the highlights have a light intensity of up to 50ft candles (as compared with about 18ft candles from a good cinema screen), and the contrast between a very bright picture and a completely dark room can

do the eyes a lot of harm, apart from revealing flicker. Dim white lights are best for both black and white and for colour pictures and these should be screened from the front of the set. Doors on the fronts of some sets make admirable "gobos" for screening off the stray light from the side, but often some kind of flap is required over the top as well. An adjustable hood or light flaps would be a good refinement for easy viewing in strong room light.

## The Cup Final

The clown-like figure who ran out on to the pitch at the end of the Cup Final bearing a placard "BBC for Sport!" was right. The BBC do seem to have forged ahead with their handling of sporting events, making full

use of their very considerable resources of equipment, with every possible modern optical and mechanical gadget for picture presentation at their disposal. This was the most exciting outside broadcast for months in which long-focus lenses and zooms, together with an expert commentary, gave viewers better-than-ringside seats, and the tension kept them on the edge of those seats! It is a pity that, apart from the commentaries, the sound side did not quite come up to scratch. The music of the massed bands had a vague, distant quality which did not match up to the picture, and the interviews down on the field (with radio microphone links) were rather poor and lacked intelligibility. I would have thought that both sounds could

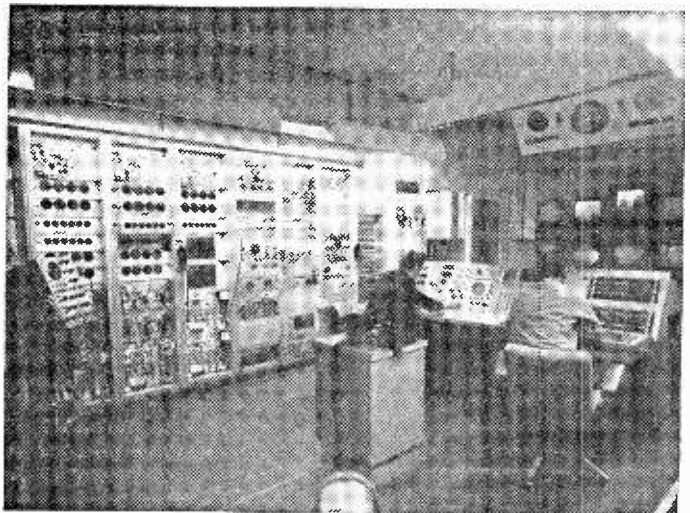

*The TV Switching Centre in the new Broadcasting House Extension in London. The Control Desk carries switching, monitoring and communications facilities. The bay-mounted equipment on the left carries vision circuit performance correction equipment, test equipment and vision and sound line jackfields.*



have been improved with a few really good local radio microphone sets supplemented by super-directional microphones such as the dish reflector type used by David Attenborough for picking up distant bird noises.

Zoom lenses were used with great effect. Cutting from long-shot to close-up during the game was well carried out, excepting for some of the goal or corner kicks. In these cases the vision mixer sometimes cut to the long shot as the ball was kicked or even just before that moment. In the next long shot the eye wandered all over the screen for a few moments trying to locate the ball. Much better to have cut to a fairly long shot before the player made his corner kick, so that the eye could watch the kick and follow the ball through. The slow-motion reproduction of the initial goal by Spurs was excellent.

#### **Wagon Train**

The wagon wheels are moving again, this time on BBC television, and the first episode of this series, with Joseph Cotten as the guest star, was a splendid start. This is a very professionally made series, beautifully directed, photographed and recorded, and the BBC put it over in fine style. Quality of picture was excellent, and I was not surprised to hear that a 35mm print was used on the original twin-lens Cintel flying spot telecine equipment at Lime Grove. The picture tonal values of which this model is capable have not been surpassed, though it must be over ten years old.

Built like a battleship and capable of running 35mm film only, it was more or less superseded by other types of flying spot or vidicon telecines which can cope with slides and 16mm film in addition to 35mm. But its popularity with the engineers who handle it has never changed, and the advent of colour TV will, I think, revive its general use. With the exception of Westward, the BBC are the only user at the moment. "Wagon Train" returns with the old formula, predictable situations and hokum dialogue—but excellent of its kind and it is almost certain to secure high TAM ratings in its long run during the months to come.

Another welcome return is "The Rag Trade", in which the

hilarious goings-on in a clothing factory are put over with verve by Peter Jones, Miriam Karlin, Shiela Hancock, Reg Varney and, of course, little Esma Cannon, the life and soul of the party! Comedy scripts of this type are not too easy to write, but Ronald Wolfe and Ronald Chesney seem to have an inexhaustible supply of ideas for varying the comic angles on labour relations. This show is video-taped and the technical qualities are good—but not so good as the 35mm film used for "Wagon Train".

#### **Symbolism**

Close-ups of a spider's web, a bitten apple, a broken mirror or a guttering candle were once favourite devices of the silent screen and early talkies, for symbolising the dramatic situation preceding it. It is rather a dated device and seemed all the more old fashioned when it was used several times—in the form of a close-shot of a Punch and Judy show — during "They Hanged My Sainly Billy", which was a TV adaptation by Rosemary Hill of Robert Graves' book on "Palmer the Poisoner". This was a long play which was distinguished by a number of remarkable acting performances, notably by Patrick Wymark as Palmer, who headed a large cast. This play could very easily have fallen into the category of the blood-tub type of melodrama burlesqued these days, like "The Murder in the Red Barn", if it

had not been so well directed by Peter Dews. The frequent interruptions with inserts of the Punch and Judy hanging scene very nearly brought this about. As each dramatic situation ended, I was anticipating a parallel in the puppet show insert.

#### **TV in NE Scotland**

It is good to hear that the most northerly ITV programme Company, Grampian, has made good progress since it opened some eight months ago. With the two transmitters in operation at Durriss and Mouteagle, the number of homes able to view Grampian has increased from 98,000 on the opening night, to over 120,000. It is a lively organisation, presenting a fair quota of local programmes and local news, including local newsreel snips. Grampian has its own processing plant for speedy development of 16mm film. The smaller regional companies, like Grampian at Aberdeen, Border at Carlisle and Ulster at Belfast, have much smaller populations in their areas than London or Northern (Lancashire and Yorkshire). With less than a million each, compared with about 13,000,000 population each for London and Northern areas, the revenue from selling commercial slots is correspondingly less. Nevertheless, they achieve a high standard of presentation and in most cases put on more local programmes than the corresponding local BBC station.

## **PRACTICAL WIRELESS**

### **Chief Contents of the July Issue**

THE EVEREST TUNER  
 A 4-VALVE SIGNAL TRACER  
 SERVICING TAPE RECORDERS  
 POWER RECTIFIER CIRCUITS  
 SHORT WAVE LISTENER'S LOG  
 VERSATILE LOW CURRENT H.T. SUPPLY  
 THE ALPHA THREE PERSONAL TRANSISTOR SUPERHET  
 NEONS IN THE EXPERIMENTER'S POWER PACK  
 ELECTRONIC PROCESS TIMER  
 HOW TRANSISTORS WORK  
 ON YOUR WAVELENGTH  
 THE P.W. TROUBADOUR  
 BOOKS REVIEWED  
 ETC., ETC., ETC.

**ALL TUBES  
GUARANTEED 12 MONTHS  
Carriage Free**  
Speedy Passenger Train despatch.

**NEW**

12"	MW 31-74 etc.	<b>£5.5.0</b>
14"	MW 36-24/44 Limited quantity	<b>£6.6.0</b>
17"	MW 43-69 (limited) CRM 171, 172	<b>£7.7.0</b>



**COMPLETELY REPROCESSED**  
REBUILT, RESCREENED, REALUMINISED TUBES OF THE HIGHEST QUALITY

14" ... ..	<b>£5.5.0</b>
15"—17" ... ..	<b>£5.10.0</b>
21" ... ..	<b>£8.0.0</b>

**"CLARION" TRANSISTOR**

**BATTERY TAPER RECORDER**  
Push-button controls. Capstan drive. 3 1/2 i.p.s., constant speed. 50 hours on four U.2 torch batteries. Portable. Durable plastic case. Free illus. leaflet. Complete with mike and tape. Our **15** GNS. List Price **25** Gns. Price **15** Carr. **7/6**  
**NOW ONLY**



**LINE OUTPUT TRANSFORMERS**

Direct Replacements for 500 sets.

Bush, TV 11A, B; 12A, B; TVF 12A, TUG12A, B; TRG 12A, B	.. 45/-
TV12AM; TV22, 24; TRG24, TLG24	.. 70/-
Cosmor, 830, 931, 933, 934, etc.	.. 62/8
Ekon, TS146; TS113-114; T161	.. 47/6
T221, 231; TSC311, etc.	.. 59/6
Ferguson, 841, 2, 3; 941 to 945	.. 58/6
980T-988T; 103-145T; 203-246T	.. 60/6
Ferranti, 14T3, 14T4, 17K3, 17T3-4, 14T2, T1205, T1215, T1225, T1326, T1405, T1415, T1425, T1505, T1825	.. 65/-
G.E.C. and H.M.V. mostly	.. 55/- to 60/-
Invicta, T101-104; T108-110	.. 52/-
T114-126; T133-142	.. 60/-
Murphy, V114C, V116C, V118C	.. 45/-
V120C, V180, V178, V200, V209C	.. 57/6
V240, 250	.. 94/-
V214, 216	.. 98/6
Philips, 114 UF/UM, 115 U, 1437 U, 1446 U, 1726 U, 1746 U, 1747 U	.. 73/-
3R3A, 463A, 563A, 663A	.. 80/-
Psy, LV30, 16T, CS17, VT17	.. 69/6
CTM4, V4, VT4, VT7, VT7	.. 55/-
Urtm, 814, 815, 817, 915, 917	.. Vw60
YVA730, YVW84, VWW720, V710, (complete assembly with U25)	.. 77/6
14/53, 15/60, 17/50, 17/53, 17/60, 17/63-4, 17/70-1-2, 21/50, 21/60, 21/70-1-2	.. 60/-
All Ultra Frame O.P.T.'s	.. 26/6
Add post 3/6.	
100 mixed resistors, 1W-2W-6/8, post 1/-.	

**LINEARITY AND WIDTH Controls.**  
Sub-assembly. Complete 5/- P.P.1/-.

Scan Colls, 90° new, 19/6, P.P. 2/9.  
P.O.P.T. to match, 15/6. P.P. 2/9.

**RADAR KILOVOLT**

Tests actual EHT volts at C.R.T. anode etc. with **SAFETY** and **ACCURACY**. End guesswork with this essential item of your kit. **£3.17.6.** Post 3/6.

S.A.E. with enquiries please.  
**5 Westward Way**  
Preston Road, Harrow, Middx.  
Tel: WOR 2663

**WESTWAY RADIO**

**A NEW-PRACTICAL WAY  
of UNDERSTANDING  
Radio : Television  
Electronics**

Including: Transistors; VHF/FM; Hi-Fi equipment; Computers; Servo-mechs; Test instruments; Photo-electrics; Nuclonics, etc.

Radiostructor—an organisation specialising in electronic training systems—offers a new self-instructional method using specially designed equipment on a "do-it-yourself" basis. You learn by building actual equipment with the big kits of components which we send you.

You advance by simple steps, performing a whole series of interesting and instructive experiments—with no complicated mathematics! Instructional manuals employ the latest techniques for showing the full story of electronics in a practical and interesting way—in fact, you really have fun whilst learning! Fill in the coupon below for full particulars.

**POST NOW**

TO RADIOSTRUCTOR (DEPT. G-40)  
READING, BERKS.

Please send brochure, without obligation to:

★Name \_\_\_\_\_ } **BLOCK**  
Address \_\_\_\_\_ } **CAPS**  
\_\_\_\_\_ } **PLEASE**

(We do not employ representatives)

7/62

**FREE** THIS BOOK WILL INTEREST YOU!

FOR .. Your Career  
.. Your Own Business  
.. An Absorbing Hobby

**Radiostructor**  
EQUIPMENT COURSES

**RADIOSTRUCTOR**  
LEADS THE WORLD  
IN ELECTRONICS TRAINING

# AERIALS

BAND I BAND II BAND III



**Combined Arrays I and III**  
 1+3 Element Loft Mounting .. 38/3  
 1+5 Element Loft Mounting .. 46/9  
 1+3 Element Wall Mounting .. 45/3  
 1+5 Element Wall Mounting .. 61/-  
 1+3 Element Chimney M'ting. .. 57/10  
 1+5 Element Chimney M'ting. .. 66/9

**Band I**  
 Single Dipole Wall Mounting .. 24/7  
 Single Dipole Chimney M'ting. .. 40/2  
 X Aerial Chimney Mounting .. 62/3  
 H Aerial Chimney Mounting .. 67/7

**Band III**  
 3 Element Yagi Wall Mounting 33/-  
 6 Element Yagi Wall Mounting 43/-  
 9 Element Yagi Wall Mounting 56/-  
 Chimney Lashing Mounting add 10/-  
 Double Array, only with clamp 83/-

**Band II**  
 Single Dipole Wall Mounting .. 20/5  
 Single Dipole Chimney M'ting. .. 29/9  
 H Array Chimney Mounting .. 52/4

## REPAIR KITS

Band III Folded Dipole with Insulator, complete .. 9/3  
 Band I Insulator to fit 1/2 inch Elements, or 1 or 1/2 inch Boom .. 8/4  
 Band III Insulator to fit 1/2 inch Elements, 1 or 1/2 inch Boom .. 4/3  
 Waterproof Dimplexers .. .. each 11/6  
 High Grade Aluminium Tube: 1/2 in. dia. 7d. ft., 1 in. dia. 9d. ft., 1 in. dia. 1/2 ft., 1 in. dia. 1/4 ft., 1 1/2 in. dia. 2/3 ft., 2 in. dia. 3/9 ft.  
 Co-ax. Semi Air Spaced, 7d. yd. .. Co-ax Plugs 1/2 Send 6d. for Lists. Please state Channel when ordering. Cash with Order? Post and Packing 3/- extra.

**SATISFACTION OR MONEY BACK GUARANTEE**  
**WALKER & SQUIRES**  
 PINNOX STREET, TUNSTALL, STOKE-ON-TRENT  
 Phone: Stoke-on-Trent 88767

# "THREE STAR"

RE-BUILT TELEVISION TUBES

- ★ Manufacturer's Own Make of Gun
- ★ Re-screened for Greater Contrast
- ★ Aluminised for Better Brightness

## TWO WAY TESTED

Free carriage and insurance.

ALL TYPES AND SIZES

12" - £4.10      14" - £4.15

15" - £5. 0      17" - £5.10

21" - £7. 0

C.O.D. or Cash with order.

## DARLING ELECTRONICS

Dept. TV, 62 High Street, Croydon, Surrey

MAIL ORDER ONLY—NO CALLERS

# VALVES SAME DAY SERVICE

NEW! TESTED! GUARANTEED!

### SETS

1R5, 1S5, 1T4, 3S4, 3V4, DAF91, DF91, DK91, DL92, DL94 .. Set 4 for 19/6  
 DRF96, DF96, DK96, DL96 .. .. . 4 for 27/6

OA2 11/6	6L18 10/-	30L15 11/-	EBF89 8/9	EZ41 7/6	U26 9/3
1A7GT 11/6	6L19 10/-	30P19 14/6	EBL21 13/6	EZ80 6/3	U30 6/-
1D5 7/6	6LD20 8/9	35A5 14/-	ECL30 13/6	EZ41 6/6	U32 4/6
1H5GT 9/6	6P1 7/-	35L8GT 8/3	ECC81 5/-	KT33C 7/-	U78 4/6
1N5GT 9/-	6P25 8/6	35Z4GT 5/6	ECC82 6/3	KT41 11/6	U91 14/6
1R5 6/-	6P28 12/-	35Z5GT 8/3	ECC83 7/-	KT44 5/9	U281 17/-
1S4 8/-	6Q7G 6/-	50CD6G 27/3	ECC84 8/3	KT61 9/6	U291 16/6
1S5 5/3	6Q7GT 8/6	50L5GT 9/-	ECC85 7/9	KT93 6/6	U301 17/-
1T4 3/6	6SLTGT 5/9	85A2 11/6	ECF80 7/6	MU14 8/6	U801 21/-
1U5 5/9	6SN7GT 4/9	AZ31 9/6	ECF82 8/6	N18 7/-	UAB80 8/6
3A5 9/-	6U4GT 9/9	B36 7/6	ECH21 13/6	PC95 10/-	UAF42 8/3
3Q4 7/-	6V6G 4/6	CL33 12/3	ECH35 6/3	PC97 10/-	UB41 8/6
3S4 8/-	6V6GT 7/6	CY31 10/6	ECH42 8/9	PCC84 7/6	UBC41 7/9
3V4 7/-	6X7GT 4/6	DAC32 9/-	ECR81 7/9	PCC89 9/3	UBF80 8/3
5U4G 4/6	6X5GT 4/9	DAF91 5/3	ECH83 8/6	PCF80 7/9	UBF89 8/-
5V4G 8/9	8B6 9/-	DAF96 7/6	ECL80 7/6	PCF82 8/-	UCC84 13/3
5Y3GT 6/-	7B7 7/6	DCC90 9/-	ECL82 9/-	PCF86 14/-	UCC85 7/6
5Z4G 9/-	7C5 7/6	DF33 9/-	ECL86 15/-	PCL82 9/-	UCF80 14/6
6AL5 3/9	7C6 7/6	DF39 3/6	ECR38 4/6	PCL83 10/6	UCH21 13/6
6AM6 3/6	7H7 7/6	DF96 7/6	EF40 11/6	PCL84 10/-	UCH42 8/-
6A05 6/-	7S7 9/-	DH76 4/9	EP41 7/9	PCL85 10/6	UCH81 8/9
6AT6 8/-	7Y4 7/-	DH77 6/9	EP80 4/9	PENA4 11/-	UCL82 9/9
6BA9 5/9	12AT6 6/-	DH81 9/-	EP85 4/9	PEN36C 8/-	UCL83 13/3
6BB8 5/9	12AT7 5/-	DK32 11/-	EP86 7/-	PL36 11/6	UF41 7/6
6BH6 5/9	12AU7 6/3	DK91 7/-	EP89 7/-	PL81 9/6	UF89 7/-
6BJ6 5/9	12AX7 7/-	DK92 7/6	EP91 3/6	PL82 7/6	UL41 8/3
6BR7 9/6	12K7GT 4/9	DK96 7/6	EP92 3/9	PL83 7/6	UL84 6/6
6BW6 8/-	12K8GT 9/6	DL33 8/-	EL33 9/6	PL84 8/6	UM4 14/-
6CD6G 27/3	12Q7GT 4/9	DK35 9/6	EL41 9/6	PX4 10/-	UR1C 8/-
6F1 10/-	12SN7GT 7/6	DL92 8/-	EL42 9/-	PX25 9/-	UY21 13/6
6F6G 6/6	12Z3 10/6	DL94 7/-	EL84 6/6	PY32 11/6	UY41 6/6
6F13 10/-	20F2 17/-	DL96 7/6	EM34 7/3	PY80 7/6	UY85 6/6
6P14 10/-	20L1 16/-	EABC80 5/6	EM80 8/-	PY81 7/-	VP4B 9/6
6P23 10/-	20P4 20/-	EAF42 8/6	EM81 8/-	PY82 6/6	VP41 5/6
6KTG 11/1	20P5 14/9	EB91 3/9	EM84 9/6	PY83 7/9	VF1321 18/6
6K7GT 5/-	25A6G 8/-	EB93 5/-	EY51 7/6	T41 7/6	W76 4/9
6K8G 5/-	25L6GT 7/9	EB41 8/-	EY86 7/9	U22 7/3	W77 3/9
6K8GT 9/-	25Z4G 8/6	EBP80 8/6	EZ40 6/9	U25 12/-	Z77 3/6



Your most useful on-the-job "tool"! Quickly and easily pin-points the exact trouble in any TV set. Covers 700 symptoms, 700 trouble spots. Over 340 cross-indexed pages; 50 time-saving Check-Charts; 290 diagrams and photos; explanation of circuits and designs.

**SEND NO MONEY!**  
 Just mail coupon for free trial. After 7 days send only 3/- weekly or return book and pay nothing!

**FREE TRIAL OFFER!**  
 Mail Coupon NOW!

Mail Order Division, SIM-TECH BOOK COMPANY, Dept. P.10., Gater's Mill, West End, Southampton, Hants.

RUSH. TV Troubles 31/6d. plus 1/6d. postage for 7 day FREE TRIAL as per offer.  
 Tick here if enclosing full price, we pay postage; Same 7 day money back guarantee

Name \_\_\_\_\_  
 Address \_\_\_\_\_  
 City \_\_\_\_\_ County \_\_\_\_\_

# READERS RADIO

24 COLBERG PLACE, STAMFORD HILL LONDON, N.16 STA. 4587

Post 6d. per valve extra.  
 Any Parcel Insured Against Damage in Transit 6d. extra  
 Any C.O.D. Parcel 3/- extra.

# Letters to the Editor

The Editor does not necessarily agree with the opinions expressed by his correspondents.

**SPECIAL NOTE:** Will readers please not that we are unable to supply Service Sheets or Circuits of ex-Government apparatus, or of proprietary makes of commercial receivers. We regret that we are also unable to publish letters from readers seeking a source of supply of such apparatus.

## EHT TESTER

**SIR,**—A useful gadget for testing quickly whether an EHT/line O.P. transformer is functioning can be made very simply by fixing a 0.5W neon indicator lamp on the end of a 6in. glass rod (without any connections, of course). When the lamp is held near the line output transformer, say ½in away, the lamp will glow very brightly if the transformer is working, thus indicating that the line timebase is in order as far as the EHT rectifier valve. No actual connection is required to any part of the EHT system, which makes this a safe way of testing with no risk of shocks.—A. H. WILLERTON (Ilkley, Yorkshire).

## SOME COLOUR STATISTICS

**SIR,**—I have always advocated and urged progress in respect to colour television developments in this country. I have been collecting reports, correspondence and technical literature dealing with this complex subject since 1959 and I think the following figures, etc., will be of interest not only to radio hams but, I hope, also to the more wider public field. I have at present something like 45-50 letters in my files from various manufacturers both in this country and from abroad. About half that amount again I possessed in the early days, but those got thrown away, mainly because of a general lack of interest in this field (apart from manufacturers), and out of these 45 letters still on file about 38 are letters from British firms. It can be said, simply by gleaning the facts from this literature, that most of our companies protect their know-how to the absolute limit, and I'm not saying that this is a bad thing entirely, but I cannot help noticing the strong contrast on the other side, where foreign hand-outs have been more than generous, particularly from the American and German points of view. In America, for example, the Hazeltine Corp., N.B.C. Corp., Emerson, Du-Mont Labs., C.B.S., R.C.A. and Philco have all been most helpful, and even companies in Asia and Japan have given some idea of their progress in these fields.—K. R. CRASKE (Lincoln).

## TV DX RECEPTION

**SIR,**—As a reader of long standing of PRACTICAL TELEVISION may I make a somewhat belated reply to Mr. W. R. Carson's letter in the April 1962

issue regarding TV reception at distances of over 100 miles?

I would respectfully disagree with his suggestion that regular reception at distances of over 100 miles is not possible in this country.

My own experience is very much to the contrary. Being of French origin I am particularly interested in French TV and since a removal to the South Coast some time ago I have devoted some time in establishing a *regular daily* link with RTF/TV. The station chosen was Caen—Mt. Pincon in Normandy on Band I, Channel F2. The aerial used is a four-element folded dipole at 50ft height.

For over 15 months now I have never failed to resolve the RTF picture *daily* and the distance from Poole here to the transmitter at Mt. Pincon is approximately 140 miles. I would not claim that the image is always 100%, but at best it compares well with BBC standards in spite of the fact that the I.F. bandwidth is cut from 13Mc/s (RTF standard) to the 3.5Mc/s English standard by employing an English receiver, but this is considered worthwhile in order to avoid English TV pattern interference.

In addition to the above, fairly regular reception is obtained from the following French stations: Brest Roc-Trédudon—185 miles on Band III, Channel F8, and Lille-Bouvigny—220 miles on Band III, Channel F8A. (None of these stations is over 20kW in power.)

In this area I have three ITV regular programmes, one of which is St. Hilary TWW, Channel 10 at 100 miles, and this always gives a good picture (with a five-element aerial at 33ft up).

I have been a TV experimenter since 1933; I started on scanning discs then and my present hobby is DX/TV.

The log to date is 45 television stations in 15 countries, including the U.S.S.R., Poland, Hungary, etc., via sporadic E propagation.

In addition to the above sets I have a CCIR European standards 17in. receiver and a number of rotatable, vertical and horizontal aerials at both 50ft high and 33ft high.

I am really only an amateur in DX/ITV, for I have a friend whom I am visiting soon in Belgium, a M. Jacques Herreman, whose total is 109 TV stations in 20 countries and whose regular daily reception includes at least six British BBC and ITA stations at over 100 miles.

I hope that these few lines will be of interest and suggest that other readers might find their DX/TV hobby as interesting as I do. If so I would willingly help over station identification if anyone would wish to contact me.

With my best wishes to you and the magazine and my grateful thanks for all the interest I have found in your articles.—C. N. RAFAREL (10 Netley Close, Parkstone, Poole, Dorset).

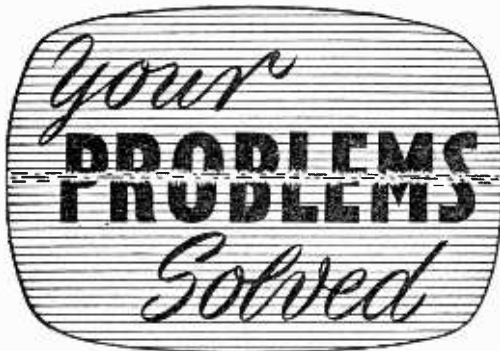

*Whilst we are always pleased to assist readers with their technical difficulties, we regret that we are unable to supply diagrams or provide instructions for modifying surplus equipment. We cannot supply alternative details for constructional articles which appear in these pages. WE CANNOT UNDER-TAKE TO ANSWER QUERIES OVER THE TELEPHONE. The coupon from p. 500 must be attached to all Queries, and if a postal reply is required a stamped and addressed envelope must be enclosed.*

#### PYE V7

I wish to use a Cyldon turret tuner with this receiver in order to receive the ITV programmes. This model has an I.F. of 16-19Mc/s but the turret tuner has an output of 35-38Mc/s. Will you kindly advise me which coils I should rewind in the tuner in order to match the unit to the set I.F.?

I am advised that to change the I.F. of the set will involve difficulties on sound rejection and the best conversion is to change the Cyldon output frequency, do you agree with this?—E. V. Elliott (London, N.W.4).

To convert your tuner to 16 Mc/s, it will be necessary to replace the I.F. transformer on top by a 16Mc/s coil, and also to replace the tuner biscuits (local oscillator section only) by appropriate 16 Mc/s equivalents, thus converting your tuner to a U16H. We would add that we have not tried this conversion ourselves and therefore cannot speak from practical experience.

#### PHILIPS 1101UF/15

For the past month a fault has appeared, namely very jagged edges on the vertical outlines of the picture. When first switched on the picture is quite good but after 5-7 minutes the jagged edges appear. I have replaced the horizontal oscillator ECL80, the horizontal output PL81, also the PY80 without result.—E. A. Trowse (Brighton, Sussex).

The symptoms you describe usually need the use of an oscilloscope to determine at which point noise is entering. We suggest you check particularly the small  $\frac{1}{2}$ W resistors in the timebases, as they have a habit of going high and becoming noisy.

#### MURPHY V250

I can get ITV and BBC on sound only. The tube is dead apart from a small light in the neck.

The valves all light up.—W. Bradwell (Preston, Lancashire).

We suggest you check inside the screened EHT compartment at the back of the receiver suspecting especially the 20P4 line output valve, which is the largest valve in the compartment.

#### EKCO TV05

Could you advise me how to cure vertical judder, and slip on this receiver? Adjustment of the vertical hold is very critical and it will lock for a limited period only. Frame and sync valves appear to be in order.—N. Pilkington (Stockton-on-Tees).

Replace the Q3/4 metal interlace diode, which is below the chassis near the frame oscillator transformer. This in appearance is similar to a small resistor with orange and yellow bands.

#### COSSOR 937

I have just fitted a new tube and have a very good picture, but it is 1½in. out of centre leaving a blank space on the right-hand side of the screen. The horizontal hold is at the end of its travel and on turning it back the gap widens. Adjustment of the line-hold control only gives a "wickerwork" appearance to the picture. The picture centring adjustment on the tube neck will only move the picture up or down and not sideways.—J. W. B. Painter (Stourport-on-Severn, Worcestershire).

You are mistaken in thinking that the centring adjustment only moves the picture vertically. You will find that a right angle movement to that which gives vertical shift will give horizontal shift. For example if a lever is used and moving it side-to-side produces vertical shift, an in-and-out movement will move the picture sideways. If a ring magnet is used, rotate, at the same time screwing the knob to obtain the desired shift.

#### KBQV20

This set is showing sound-on-vision and the picture moves with the sound. I've replaced the PCC84 and PCF80 valves in the tuner circuit and also the PL81 (V7) and PCF80 (V6). Changing V4 with V9 (6BW7) or V10 and V12 (PCL82), has no effect. Since replacing the tuner valves the fault is more apparent on BBC.—K. Taylor (London, E.4).

Short the AGC line to chassis and adjust L36 for minimum sound-on-vision.

#### INVICTA 120T

On switching on, the sound is normal and after about one minute the timebase whistle is heard. When the picture appears it is very cramped and folded in from the sides. Soon after this the heater of the EY51 fades out slowly. The whistle can still be heard but much fainter. I have replaced the PY81 efficiency diode which when tested was found to be very low but this does not cure the trouble. I tested for EHT but found no spark on the cathode of the EY51. The frame hold is critical but I think this is due to sound-on-vision as the picture can be stopped rolling by very fine

(Continued on page 499)

# LAWSON

# DIRECT REPLACEMENT TELEVISION TUBES



LAWSON TUBE WITH NEW SILVER ACTIVATED SCREEN AND "MICRO FINE" ALUMINISED

12 MONTHS' FULL REPLACEMENT GUARANTEE

## DESIGNED FOR PERFORMANCE

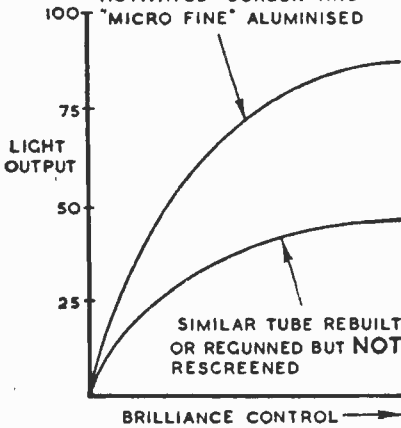

The modern Lawson television tubes are specially designed to give the older types of television set very much improved performance. The new silver activated screens are much brighter with better contrast, exclusive "microfine" controlled thickness aluminiumising gives 50% more light output (superb daylight viewing). New small anode aperture electron guns by Mullard, Mazda, G.E.C., Brimar, E.E., Cossor, etc., give needle sharp definition and focus, and silicon vacuum pumping plus depth formed cathodes give very long life. Each tube is 100% BRAND NEW (glass excepted), and is designed to fit exactly as the original tube ensuring complete accuracy and efficiency.

ALL MAKES AND TYPES FROM STOCK

EXPRESS PASSENGER SERVICE—Orders received by 3 p.m. are dispatched same day. Special direct services to Scotland and Ireland.

Full fitting instructions with every tube.

**LAWSON TUBES LTD.** Tel. 2100  
2 PEACHFIELD CLOSE, MALVERN, WORCESTERSHIRE.

12' — £1.10.0  
14' — £5. 5.0  
15-17' — £5.15.0  
19', 21', 23' also available

C.O.D. or C.W.O.

**10/-**

Gladly refunded if you wish to return your old tube (excepting 12')

CARR. and INS. 7/6

## NEW VALVES!

Guaranteed Set Tested  
24-HOUR SERVICE

1R5, 1R5, 1T4, 3B4, 3V4, DAF91, DF91, DK91, DL92, DL94, SET of 4, 18/6.	DAF96, DF96, DK96, DL96, SET of 4, 26/-.
1D5 7/-	DL36 9/6
1R5 5/6	DL92 5/11
1R5 4/6	DL94 6/6
1T4 3/6	DL96 6/9
3B4 5/11	EB91 3/-
3V4 6/9	EB41 7/6
5U4C 4/6	EBF90 7/9
6Y3GT 5/9	EBL21 12/-
5Z4G 3/6	ECC40 13/-
6AM6 2/9	ECC81 4/9
6K7G 1/9	ECC82 5/9
6K8G 4/9	ECC83 6/9
6Q7G 5/6	ECC84 5/-
6V6G 4/-	ECC85 7/6
6V8GT 6/6	ECF80 7/3
6X5GT 4/6	ECF82 8/3
12K7GT 4/3	ECH21 12/-
12K9GT 9/-	ECH42 7/9
12Q7GT 4/6	ECL80 5/9
12SN7GT 7/3	EP40 11/-
3L8GT 8/-	EP41 7/6
3Z4GT 5/-	EP80 4/6
AZ51 8/9	EP86 4/6
CL33 11/-	EP96 8/6
DAC32 8/6	EP89 6/9
DAF91 4/6	EP91 2/9
DAF96 6/9	EL41 9/-
DF30 8/6	EL84 6/9
DF91 3/6	EF51 7/3
DF96 6/9	EY86 7/6
DH77 6/-	EZ40 6/-
DK32 10/6	EZ41 7/6
DK91 5/6	EZ80 5/9
DK92 7/3	EZ81 6/-
DK96 7/3	MU14 6/-
DL33 7/6	PCC84 7/-

Postage 6d. per valve extra. Any Parcel Insured Against Damage in Transit 6d. extra. Any C.O.D. Parcel 3/- extra. O/Noe address, no callers.

**GERALD BERNARD**

(Note new address—formerly of Leeds)  
83 OSBALOESTON ROAD,  
STOKE NEWINGTON, LONDON, N.16

## Radio and Television Retailers' Handbook

Whether proprietor or manager, established or aspiring, this book will be a constant companion on your road to success.

by F. X. Carus. Postage 1/6.

35/- TELEVISION SERVICING HANDBOOK, by G. J. King. 30/- Postage 1/3.

WORLD RADIO TV HANDBOOK 1962. 18/9. Postage 1/-.

RADIO CONTROL HANDBOOK, by H. G. McEntee. New ed. 40/- Postage 1/-.

HANDBOOK OF ELECTRONIC TABLES & FORMULAS, by D. Herrington & S. Meacham, 15/- Postage 9d.

THE HOME ELECTRICIAN, by F. J. Camm. 12/6. Postage 6d.

THE AMATEUR RADIO HANDBOOK. An R.S.G.B. Pub. 34/- Postage 2/-.

RADIO VALVE DATA, 7th ed. Compiled by "VW". 6/- Postage 1s.

COMPLETE CATALOGUE 11/-.

## THE MODERN BOOK CO.

BRITAIN'S LARGEST STOCKISTS  
British and American Technical Books  
19-21 PRAED STREET  
LONDON, W.2

Phone: PADDington 4185  
Open 6 days 9-6 p.m.

## FIRST-CLASS TELEVISION and RADIO COURSES

### GET A CERTIFICATE!

After brief, intensely interesting study—undertaken at home in your spare time—YOU can secure your professional qualification or learn Servicing and Theory. Let us show you how.

### FREE GUIDE

The New Free Guide contains 132 pages of information of the greatest importance to those seeking such success-compelling qualifications as A.M.Brit.I.R.E., City and Guilds Final Radio, P.M.G. Radio Amateurs' Exams, Gen. Cert. of Educ. London B.Sc. (Eng.), A.M.I.P.E. A.M.I.Mech.E., Draughtsmanship (all branches) etc., together with particulars of our remarkable Guarantee of

### SUCCESS OR NO FEE

Write now for your copy of this invaluable publication. It may well prove to be the turning point in your career.

FOUNDED 1885—OVER  
150,000 SUCCESSES

NATIONAL INSTITUTE OF ENGINEERING  
(Dept. 462), 148 HOLBORN  
LONDON, E.C.1

S. Africa: P.O. Box 8417, Jo'burg.  
Australia: P.O. Box 4570, Melbourne.



Outstanding offer of

**guaranteed rebuilt cathode ray tubes . . . . 59'6** each

12" & 14" Types MW 31-74, MW 36-24, SE 14-70; 4/14 C14 FM

Carriage paid  
CASH WITH ORDER

SIMILAR BUT PARTLY USED, GUARANTEED 30/- EACH

**Tates**  
ELECTRONIC SERVICES LTD

3 Waterloo Road,  
Stockport, Cheshire

Telephone: Stockport 7301

If you have started or plan to start your own business you need . . . .

**RADIO AND TV RETAILERS' HANDBOOK**

by F. X. Carus



Provides a complete reference book on the business side of radio and television retailing, written by the Managing Editor of the *Radio, Television and Electrical Dealer* - the official journal of the R.T.R.A. For the man who wishes to run his own business or to manage a store, this book provides detailed guidance for a successful and profitable business career. For those already running an established business, the book is full of practical hints on how this can be built up to the maximum possible extent, using modern systems of management. Company formation, staff selection and training, window display and publicity, servicing facilities, stock selection and control, and management techniques are some of the important topics discussed with a down-to-earth approach.

A business investment for only 35s.

FROM ALL BOOKSELLERS

. . . or in case of difficulty 37s. by post from GEORGE NEWNES LTD., Tower House, Southampton Street, London, W.C.2.

**REBUILT TV TUBES FULLY GUARANTEED 12 MONTHS**  
Complete New Gun Fitted In Every Tube

- 12in. ... .. £4.00
- 14-15in. ... .. £4.10.0
- 17in. ... .. £5.0.0
- 21in. ... .. £7.0.0

Immediate Delivery. Carr. and Ins. 10/- extra. ALLOWANCE ON OLD TUBE

**NU-GUN TELETUBES 3 THE MEWS**

Duckett Road, Harringay, London, N.4  
Telephone: MOUNTview 2903

**EXPRESS ELECTRONICS ROSEDENE LABORATORIES KINGSWOOD WAY, SELSDON, SURREY**

**VALVES NEW TESTED AND GUARANTEED FOR THREE MONTHS**

1C1	7/6	6BA6	6/-	12AT7	6/-	12DH7	7/6	6E90	8/-	PCL84	7/6
1C3	8/-	6BE6	7/-	12AU7	6/9	DH77	6/-	6E86	9/-	PL81	12/6
1F1	8/-	6BH6	5/9	12AX7	6/9	DH142	8/6	6E91	4/-	PL82	7/-
1F3	7/6	6BL6	5/9	12BE6	8/6	DH150	10/-	6F92	5/6	PL53	7/6
1FD1	8/-	6BR7	8/6	12BH7	10/6	DK91	7/6	EL41	8/6	PY81	6/9
1FD9	7/6	6BW6	7/6	12K9GT11	-	DK92	7/6	EL84	7/-	PY82	7/6
1J4	6/9	6BW7	7/-	12Q7GT	7/6	DK96	8/-	EM84	10/-	PY83	7/6
1P1	8/-	6D2	4/-	16A5	9/-	DL92	7/6	EM85	10/-	85A1	9/6
1P10	7/6	6F12	4/-	25AG6	8/6	DL94	8/6	EY61	7/6	UC37	11/6
1P11	7/6	6H6GT	2/-	35L6GT	7/6	DL96	8/-	EY81	10/-	UC52	7/6
1R5	6/-	647GT	7/6	25Z4G	9/-	EB91	4/-	EZ40	7/6	UT6	7/6
1S5	6/-	6K7G	5/6	30C1	7/6	EBC41	10/-	EZ80	6/-	U78	5/-
1T4	7/6	6K8G	6/-	30L1	7/6	EBF80	8/6	EZ81	6/9	UBC41	8/6
1U5	5/6	6Q7G	5/6	35L6GT	9/-	ECC81	6/-	HVR2	9/6	UC43	9/6
3Q4	8/-	6SL7GT	6/-	35W4	8/6	ECC82	6/9	KTS33	6/-	UP41	8/6
3S4	7/6	6SN7GT	8/-	35Z4GT	8/-	ECC83	6/9	KT66	11/6	UL41	8/6
3V4	6/6	6V6G	7/6	53K U	10/6	ECC84	7/6	N17	7/6	UY41	7/6
5U4G	7/6	6X4	5/-	57G3	7/6	ECP90	8/6	N18	8/-	W76	4/6
5Y3GT	5/-	6X5G	5/-	80	8/-	ECP82	8/-	N19	7/6	W142	8/6
5Z4G	8/6	6X5GT	6/-	DAP91	7/6	ECH42	9/-	N709	7/-	X17	7/6
6AK6	6/9	787	6/6	DAP96	8/-	ECH91	10/-	PCC84	7/6	X142	9/-
6AL3	4/-	8D3	4/-	DDC90	12/6	ECL80	8/6	PCF80	7/6	X130	9/-
6AM6	4/-	12AD6	11/6	DF91	7/6	ECL82	9/-	PCF82	7/6	Z77	4/6
6AT6	6/-	12AH8	10/-	DF96	8/-	EP41	9/-	PCL82	8/-	Z117	7/6

High Stability Resistors 1W 5% 50 Ω to 1M, 9d. Midget Ceramics 500 V. 9d. Coax. Super quality 1in., 6d. yd. Plugs 9d. Sockets 9d. Silicon H.T. Rects. 250v. 300 MA 1in. x 1in. 17/6. Contact Cooled 250v. 50 MA 6/6. 85 MA 8/6.

NEW TRANSISTORS by MULLARD. OC19, OC26, OC66, 25/-; OC44, OC45, 9/-; OC70, OC71, 6/-; OC72, 7/6; OC72 matched in prs. 16/-; OC74, OC75, OC78, OC81, 7/6; OC82, OC170, 9/6.

**VALVES MATCHED IN PAIRS**

EL84 17/-, N709 17/-, 6V6G 17/-, 6BW6 18/- per pair. Push Pull O.P. Transformers for above 3-15 Ω 14/6, P. & P. 1/8. 12in. P.M. Speakers 3 Ω 24/6. Baker's "Selhurst" 12in. 15 Ω 15W, 90/-, 12in. Stereo Model, 27.7.0.

**SETS OF VALVES**

DK91, DF91, DAF91, DL92 or DL94, 19/6 ECH42, EF41, EBC41, DK96, DF96, DAF96, DL96, 27/6 EL41, EZ40, 35/6 1C3, 1F1, 1FD1, 1P1, 27/6 UC42, UF41, UBC41, 1R5, 1T4, 1S5, 3S4, or 3V4, 19/6 UL41, UY41, 35/- Postage and packing 6d. Over £1 post free. C.O.D. 2/6.

**CLARKSON'S TUBE CHANGE 6A DENISON ROAD, LEEDS, 2**

Tel.: LEEDS 24578

SUPER SCREEN TV TUBES with 12 months' guarantee

Tubes all Types	Cash allowance on return of old tube	Actual Cost of Tube
12"-14" £5	15/-	£4. 5.0
15"-17" £6	25/-	£4.15.0
21" £8	30/-	£6.10.0

Carriage and Insurance 10/- extra.



(Continued from page 496)

adjustment of the fine tuner. Also on increasing the brightness the picture goes in on the left side.—P. Dechaine (Brighton, Sussex).

You should change the PL81 valve and check the 47k resistor to its top cap. Also check the 3.3k screen dropper (to pin 8) if necessary.

#### FERGUSON 406

Very bad distortion is present in this receiver, on sound only, the picture quality being good. I have changed VII (PCL82) V10 (EF80), C88 and have checked most of the resistors in the sound section. The distortion is just as if some component is over-loaded, but I cannot find which one.—W. E. Fenn (Sheffield).

Suspect open-circuit or value increase of the 2.7M resistor connected to the "anode" of the OA81 or OA91 sound interference limiter diode. Also check the diode if necessary. Check for insulation resistance the 0.01 $\mu$ F capacitor connected between pins 3 and 9 of the PCL82 output valve.

#### SOBELL T171

This set works well for 10-15 minutes and then the picture begins to roll downward. A small adjustment to the frame hold stops it for a short period but then it begins again. I repeat the adjustment with the same effect each time until the control is fully retarded. The PCL83 has been replaced with two other valves that work correctly in another receiver. Also is there anything I can do to tune the oscillator coil of Channel 11. The coil used in this tuner has no core and the fine tuner has little effect. There is no picture at all without using a pre-amp.—A. M. Pesterfield (Boston, Lincolnshire).

You should check the video amplifier—part of the frame oscillator PCF80 (V6) and the 1-2M resistor from the hold control to pin 9 of the PCF80. To tune the turret coil you should obtain a coil core or remove one from a spare coil if any are fitted on the turret. Check the PCC84 and improve the aerial if possible.

#### BAIRD TV19

Would you kindly give me details of how to proceed with fitting a new tube to this set and any special instructions on setting it up?—D. A. Limpus (Falmouth, Cornwall).

Remove the front control knobs, rear cover, bottom cover and fixing screws, the control panel and the aerial panel from the cabinet, etc. Slide out the chassis complete with the tube. Remove the tube base socket, ion trap magnet and EHT connection. Release the front tube strap or clamps and ease tube forward taking care not to impose any strain on the neck as it is withdrawn through the focus housing. Fit the new tube, secure the clamp, refit the EHT cap, ion trap magnet with the arrow pointing forward, roughly in line with pin 3 or where pin 3 would be if fitted and the tube base socket. Switch the set on and allow to warm up. Advance the brilliance control and adjust the ion trap for maximum brilliance. Centre the picture with the shift lever on the focus housing.

#### KB MV30 AND MASTERADIO TE4T

These two sets both suffer from severe horizontal brushing. An article in Practical Television of June 1961 suggests that the source of the trouble is from the EHT D.C. output point. No sparks or blue light are discernible when the chassis, line output transformer, and the EHT lead to the tube are looked at in the dark.

Is there any way of deciding whether the trouble lies in the line output transformer or the tube? Both sets have Brimar C14FM tubes. Do you consider these tubes particularly liable to this fault and is any set completely free from some degree of brushing?—S. W. T. Crunden (London, N.20).

Neither set is susceptible to brushing or corona troubles in particular and such as do occur can usually be traced to a loose top cap on the line output valve, inefficient soldering on the EHT rectifier, a slightly defective line output transformer or faulty scanning coils (least likely).

#### ALBA T717

When the contrast control is turned up, the picture becomes very bright, even when the brightness control is at minimum. Is it correct for it to operate in this way? My last receiver was an Echo and when I increased the controls, the picture used to go negative. This is not the case with the Alba receiver. Also, after a while the picture on the Alba turns from bright to dim. Could you tell me what is the cause of this?—D. R. Welch (Bournemouth).

The contrast control should have the effect of brightening the picture inasmuch as the black and white content is increased. The fact that the picture on the Ekco turned negative probably denoted a failing tube and this could also be the explanation for the picture on the Alba turning dim after a period. However it would be as well to check the valves by replacement in turn and check the operating conditions of the video amplifier, tube base voltages, etc.

#### EKCO T327

I have recently replaced the line output transformer in my set due to insulation failure. It now works well, except that if the line hold control is incorrectly set the U191 (efficiency diode) glows brighter than normal, and the U25 heater goes out. Can you tell me whether this is normal on this particular model? I feel that a fault does exist, because the breakdown of the line output transformer seemed to be due to excessive arcing. I hope you can advise me, as I do not wish to have this new transformer damaged.—W. Wilby (Knottingley, Yorkshire).

We would say that the symptoms are normal. The EHT will rise considerably if the line hold control is incorrectly set causing the symptoms you describe. The previous line output transformer probably failed due to moisture entering the plastic casing, as a number of readers have reported similar effects.

#### EKCO T283

The trouble is with the contrast control (R63) which does not function. Until recently at

maximum the picture was negative and at approximately the mid-way position the picture faded right out.

Now the picture is negative even with the contrast control at minimum. I can overcome this only by adjusting the fine tuner when I get quite a good picture but lose some volume.

I have a service sheet and have had V6 and V16 checked.—F. Bull (West Drayton).

If you are sure the 30L2 and 6D2 AGC valves are in order, check the 30L1 (V1) and then check the AGC line components particularly the 0.75 $\mu$ F capacitor associated with the 30L2 which may have shorted.

#### FERRANTI T1023F

This receiver, which is 2 years old, has developed the following fault. When switched on only one third of the picture is visible across the full width of the tube. The top and bottom of the screen are black. After 5 to 7 minutes, the picture corrects itself except for the fact that faces in the background are slightly blurred.

The height control can be advanced to make picture full height when fault is present but the picture becomes severely stretched and has to be turned back when the fault clears. Could you give me any information as to the cause of trouble? —J. Barclay (Cumnock, Ayrshire).

The 30PL1 is usually the cause of the trouble described. However, if the valve is definitely in order, check the thermistor (type VA1033) connected in the frame scanning coil circuit.

#### FERGUSON 206T

I would like to fit a new tube in my receiver, the existing one being a MW43-64. Is it possible for me to fit a MW43-69 in its place, as I understand this tube is an improvement on the earlier one? I have looked up the characteristics of the two, and the only difference I can see is the heater/cathode voltage, which is 200 on the 43-64, and 100 on the 43-69. Will I have to carry out any modifications to the circuit to accommodate this other tube, or is a direct substitution possible?—A. G. Thompson (Enfield, Middlesex).

The newer tube can be used in the Ferguson chassis and is usually a direct replacement.

#### SOBELL T24

When the picture comes on it is compressed at the bottom about two inches and pulled out at the top. It takes about twenty minutes for the picture to fill the screen and the linearity is still faulty. Valves and various components in the frame circuit have been tried without success.—J. Macpherson (Peebles).

If all the smaller components in the frame circuits are working, the trouble is probably in the frame output transformer. Poor insulation or shorting turns could give the symptom. But first make sure the smaller resistors and capacitors in the frame linearity circuit are in order.

#### PHILIPS 17TG 106U

I wish to instal the extra coil (No. A341669) to receive channel 7. Could you possibly furnish the necessary instructions?—T. Ferguson (Southport, Lancashire).

This is a fairly easy operation. It is first necessary to remove the screening from the base of the tuner to expose the turret assembly. The various biscuits will then be seen in their appropriate positions. Rotate the turret to bring the channel 7 position into view and simply insert the coil in the same way as those already in position.

After installation, the fine tuner should be set to the centre of its range and the core in the oscillator coil should be adjusted for maximum sound consistent with minimum sound on vision.

#### BUSH 24C

The screen lights up with the normal raster but there is no picture and no sound. I have recently fitted a new EY51 and PL81, but now suspect the ECL80 and PCC84, which I intend to replace.

Could you help me by confirming that ECL80 and PCC84 would cause the lack of picture and sound?—T. Fletcher (Filey, Yorkshire).

The trouble must lie somewhere in the first three stages (from the aerial) which are common to both sound and vision. Check the valves concerned and associated components. Replace faulty parts.

#### PHILIPS 1100U-15

Could you possibly help me with the following fault? The sound is perfect, but the picture has disappeared leaving a narrow band of light across centre of screen. I have substituted every valve in the set with valves that I know to be good, but still get the same effect. Could this possibly be the frame output transformer? If so, could you give me the location of this component?—F. G. Aupont (Erdington).

A fault in either the frame output transformer or, more likely, in the frame blocking oscillator transformer could be responsible. The former is located right at the end of the timebase chassis—the end remote from the mains voltage adjustment while the latter is in the centre of the same chassis opposite the line output transformer and in line with the mains dropping resistors.

### QUERIES COUPON

This coupon is available until JULY 20th, 1962, and must accompany all Queries sent in accordance with the notice on page 496.

PRACTICAL TELEVISION, JULY, 1962.

SITUATIONS VACANT

VACANCY EXISTS for TV, Radio mechanic. Country town, Southern Ireland. Box No. 33.

UNITED KINGDOM
ATOMIC ENERGY AUTHORITY
ATOMIC ENERGY
ESTABLISHMENT, WINFRITH

Electronic Instrument Mechanics

Opportunities exist for men possessing a good basic knowledge of valve and transistor electronics to carry out fault diagnosis, repair, test and calibration in the advancing field of nuclear electronic instrumentation.

Applicants should have several years' experience of electronic equipment servicing but a good basic knowledge, enthusiasm and ability to learn new techniques are equally important.

Much of the equipment is of new design and, where appropriate, training will be given to successful applicants.

Married men living beyond daily travelling distance may be eligible for housing and this will be determined at time of interview. A lodging allowance is payable whilst waiting for housing. Working conditions are good and include sick pay and pension schemes.

An application form may be obtained by sending a post card quoting your name, address and the reference EL/INST/1 to THE LABOUR DEPARTMENT, A.E.E., WINFRITH, Nr. Dorchester, Dorset.

SETS & COMPONENTS

"HEATHKITS" can now be seen in London and purchased on H.P. Free brochure. DIRECT TV REPLACEMENTS LTD., 138 Lewisham Way, SE14. TID 6686.

RATES: 4/- per line or part thereof, average five words to line, minimum 2 lines. Box No. 1/- extra. Advertisements must be prepaid and addressed to Advertisement Manager, "Practical Television", Tower House, Southampton St., London, W.C.2.

SETS & COMPONENTS, (continued)

NEW VALVES, 6 months guarantee
ECC81/2/3, EF80, PY82, 4/11; ECL80, EY51, EY86, PL84, 7/9; PCF80, PCC84, PL81, PL83, 8/3; U.25/U.26, PY32, PCL82, 9/11; U801, 6CD6G, 30L15, R19, 20P4, 19/1

P. BEARMAN

3 PANK AVENUE, NEW BARNET HERTS. Tel: Bar 1934

NEW AND SURPLUS VALVES, fully guaranteed from 3/6 each. Also reclaimed valves, perfect, from 1/6 each. Many genuine valve bargains. S.A.E. for complete list. LEWIS, 46 Woodford Avenue, Ilford, Essex.

BRAYHEAD TURRET TUNERS.

Brand New in Manufacturer's Cartons. 3/6 plus 2/6 P.P. All frequencies in stock. Plug-in type.

OSBORN ELECTRONICS LTD.

382 Brockley Road, London, S.E.4

State make and model number of set. C.W.O.

TRANSFORMERS

Line - Frame - Output - Oscillator - and Scan Coils COMPARE THESE PRICES!

L.O.P Txs.

Table listing transformer models and prices. Includes models like ALBA, BUSH, TVG, etc. with prices ranging from 48/6 to 100/-.

ALL GUARANTEED 90 DAYS

Post and Packing 3/6. (All enquiries S.A.E.)

MARLEY SUPPLIES • 21 PITLAKE • CROYDON • SURREY Croydon 8800 And at 2 Wellfield Road, S.W.16 (near Streatham Library)

TELEVISION TUBE SHOP

We have the following Unused, Guaranteed Tubes in stock now

Carriage up, but prices down.

Table listing television tube models and prices. Includes models like AW36-20,21, AW36-80, AW43-80, etc. with prices ranging from £5.76 to £12.6.

All tubes tested before despatch and guaranteed for 12 months.

CARRIAGE 7/6, via B.R.S. or 12/6 via passenger train.

TERMS £2 down balance £1 per month.

Send for our EQUIVALENT LIST for types not shown. Almost every type can be substituted.

Shop Soiled Tubes (unused)

(Subject to Availability)

12in. 3/18, 3/31 45/- Others 57/6
14in. CRM141, 2 60/- Others 57/6
17in. CRM171, MW43-69, 43-64, 75/- Plus Carriage. Guaranteed for 12 months.

TELEVISION TUBE SHOP

48 BATTERSEA BRIDGE ROAD S.W.11 BAT 6859 South of the Bridge. Open Sats. until 4 p.m.

TELEVISION TECHNICIANS
LINE OUTPUT TRANSFORMERS
SCAN COILS ETC.

LABORATORY TESTED

ALBA: T301, T304, T394, T434, T494, etc. 40/8
BUSH: TV11A, 11B, 12A, 12B, TVG12A, 12B, TRG12A, 12B
TVG26, TV32, TV33, TVG34, TVG34A, TV36, TV36, TVG36, TV36C, TVG36C, TV43
TV43, TV56, TV57, TVG56, TV62, TV63, TV66, TV67, etc. 94/-
TV80 with EY51 109/-
COSSOR: 930 and T931, 923-45, 937, 938A, and F, 939 and A and F... 61/6
943T, 940-946, 945, 945B 58/8
954F, 947, 949 68/8
DECCA: D17 and C... 69/8
DMI, DM2, DM3, DM4C 74/-
DM5, DM14, DM17, 444, 555 74/-
DEFIANT: TR1453, TR1753... 58/8
DYNATRON:
EKO: T893, TCS102, TS105, TS114, TRC124, FC138, TS158, TS103... 54/-
TRC139, FC140, T141, TV142... 78/6
T161, TC162, T164, T165, etc... 78/8
TC208, TV209, T231, T221, T231P, T245, T283, T284, T293, etc. 58/8
FERGUSON: 1037, 1057, 1137, 1357, 1457
941T-953T inclusive... 56/6
991F-997T inclusive... 68/6
203T-240T inclusive... 68/8
306T, 308T... 64/-
FERRANTI: 1473, 1475F, 157A, 17K3 and F, 17T3 and F... 47/6
17K4 and F, 178K4 and F... 47/6
17T4 and F... 47/6
1475, 178K5, 17K5... 47/6
G.E.C.: BT1251, BT1292, BT1746, BT1748, BT1743... 48/8
BT4643, BT5147, BT5246-48... 88/8
BT5348-RD, BT5643R inclusive... 48/8
H.M.V.: 1824 and A to 1931 inclusive... 66/8
1840, 1841, 1842-1848... 66/8
All models available.
INVICTA: T118, T119, T120... 54/-
All other models available.
K.B.: LFT50, LVT50, LFT80, MV60... 100/8
All models available.
MARCONI: All models available.
MASTERADIO: Most models in stock.
McMICHAEL: Most models in stock.
MURPHY: V200, V202C... 56/8
V240, V280... 94/-
PETO SCOTT, PHELLO: Most models in stock.
PAM: 908, 909, 952, 953, 958... 54/-
PHILIPS: 1768U, 2168U... 104/-
1100V, 1200V... 74/-
1220U, 1230V, 1298V... 74/-
114UE, 1141U, 115U... 74/-
1437U, 1446U... 74/-
Most models in stock.
PILOT: Most models in stock.
PYE: CTM4, FV4C, FV4COL... 54/-
V4, VT4, V7, VT7... 54/-
LV30, FV1, FV1C... 88/8
CB17F, CFM17F, CW17... 68/8
CW17C, CW17CF, CW17F, etc. 68/8
Most models in stock.
RAYMOND: Most models in stock.
REAGENTONE: All models available.
R.G.D.: 4017T, 7017, C54, etc... 58/8
Most models in stock.
SOBEL: TS17, T346... 64/-
Most models in stock.
STELLA: ST921U... 104/-
ST8617U, ST8621U... 104/-
ST8917U... 104/-
ST8641U, ST86417U... 74/-
ST8914U... 74/-
ULTRA: 86 series, 186 series, with U25, etc., complete... 78/8
Most models in stock.
VIDOR: CN4217-CN4231 inclusive... 64/-
Post and Packing 3/6. C.W.O. Only
Also: Used O.P. Tns., Scan Coils, etc.
ALL GUARANTEED 90 DAYS
(All enquiries S.A.E.)

SETS & COMPONENTS
(continued)

ROTARY CONVERTERS for TV: input both 12V and 24V; splendid reception; High Efficiency Units. £5/10/-, delivery 4/6. TEDDINGTON ENGINEERING CO. LTD., Elleryay Road, Teddington, Middx. TEDDington Lock 5454.

TV's 25/-

100% COMPLETE. PART EXCHANGE 12In. Table Sets—untested, also 14In., 35/-, Carriage 15/-.
SPEAKERS, 8/9, guaranteed. 5 to 8In. round and 7 x 4In. Carriage 2/9.
VALVES, 9d. Most types. Stamp for free list.

P.P. COMPONENTS LTD.

623 Romford Rd. Manor Pk, London E.12.

WIDNES MARKET: Rebuilt Tubes, £4/4/-.—Darwins Stall, Widnes Market, Lincs.

TUBES-AERIALS-VALVES

Regunned tubes, guaranteed one year, full range of aerials and fittings. I.T.V. boosters, valves, braided tuners. TV sets, transistor radios and all electrical appliances. Co-axial cables and house wiring cables, fluorescent fittings. All quotations without obligation. Special terms to the trade and Home Engineers. S.A.E. for Catalogue.

G. A. STRANGE

BROADFIELD, NORTH WRAXHALL, Nr. Chippenham, Wilts. Tel. Marshfield 236

VALVES EX-TV sets, 8/- doz. List stamp.—14 Cricklade Rd., Swindon.

TV SPARES
LINE OUTPUT TRANSFORMERS

A few examples from our extensive range.

TELEPHONE ORDERS SENT SAME DAY C.O.D.

Murphy V240, V250, 57/6; V280, 77/6. Ekco T221, 231, 311, 284, 330, 55/-. Pye V4/7, V4/7A, Pam 906-953, 55/-. H.M.V. 1842-9, 1840-8, 2805-5902, 69/6. Ferranti 1473-6, 1773-6, 47/6; 1472, 62/6. Bush TV53, 69/6; TV24C, 89/6. Baird P2014/7, 65/-. Masteradio T917, TE7T, T409-12, etc. 75/-. Philips 1114-5, 1437-46, 89/6; 1768, 92/6. Decca DM14, DM3C, 65/-; D17, D14, 65/-. Cossor 930-8, 62/6; Ferg. 992-8, 66/9. Alba T301, 304, 394, 484, 494, 42/6. We stock most L.O.T.'s, Scan Coils, Frame O.P.'s and Osc. Trans. New and Used (from 25/-).

PLEASE SEND S.A.E. FOR IMMEDIATE QUOTE

VALVES:—Boxed & Guaranteed. ECC81-2, 6/6; ECL80, 6/-; E.F.80, 4/6; E.F.91, 4/6; PCC84, 8/6; PCF80, 9/-; PCL83, 8/6; PL81, 9/-; PL82, 6/6; PL83, 7/6; E.B.91, 3/-; All TV Valves stocked, let us know your requirements.

Callers welcome. Open all day Saturday. Terms C.W.O. or C.O.D. Add (6d. Valves), 3/6 P. & P.

TELEVISION CONSUMER SERVICES LTD. 112 CAMBERWELL RD., S.E.5 RODney 7917

SALVAGED VALVES TESTED ON A MULLARD HIGH SPEED VALVE TESTER

Table with columns for valve types (AC/P, B36, B39, etc.) and prices (2/6, 4/-, etc.).

Table with columns for valve types (EBC41, ECC33, etc.) and prices (4/-, 2/6, etc.).

VARIABLE CONDENSERS 3-50pft concentric trimmers 3/- doz.

Table with columns for valve types (G2C CRT's, SPECIAL OFFER) and prices (16In. G.E.C. 6901, 24/- per card).

FEW ONLY LEFT 35M/OS, 108M/OS, 10M/OS TURRET TUNERS, less valves (Ex receivers) 12/6. We can often supply for the actual set you want to fit the tuner in, providing set is old enough to be stripped.

TRANSFORMERS CRT Boost Transformers. 2V, 4V, 6V, 10V, 13V. State which required 12/6ea. Heavy Duty Output Transformers, 6 ratios from 13 : 1 to 43 : 1 ... 25/-ea. Miniature Output Trans. 3/8ea. Standard Output Trans. 1/10ea. formers, Multi-match Output Transistor Driver: 1-1 CT 10/-ea. 3-6-1 CT 12/6 ea. Transistor Output: 6-6-1 CT 10/-ea. 9-2-1 CT 10/-ea. Microphone Transformers, ratio 65 : 1 ... 35/-ea.

L.F. TRANSFORMERS Standard 465 kc/s ... 12/6 per pair. Modified 465 kc/s ... 16/- per pair.

AUTO TRANSFORMERS 250W ... 67/8 ea. 100W ... 27/8 ea. 50W ... 20/-ea.

TRANSISTORISED FAULT FINDER Enables faults to be located quickly. Consists of a two-transistor, multi-vibrator in a box. Complete with battery. 32/6

CRYSTALS GENUINE MULLARD. Bored OA5 8/-, OA81 3/-, OC20 9/-, OA58 8/-, OA79 3/-, OA91 3/6

TRANSISTORS OC16W 48/-, OC75 8/-, OC19 48/-, OC72 8/-, OC26 25/-, OC85 8/-, OC44 11/-, OC78 8/-, OC45 10/-, OC81 8/-, OC70 8/6, OC82 18/-, OC71 8/6, OC170 17/6

TERMS: C.W.O. or C.O.D. Orders under £1, P. & P. 1/3. Open till 11 p.m. most days.

3d. stamp for list or 9d. for full catalogue Dept. PTA

Arion Television 4 Macted Road, S.E.15 NEWX 7152

WYNDSOR TELEVISION TECHNICAL DIVISION .T. ALBANS RD., BARNET, HERTS. BAR 1769

**SETS & COMPONENTS**  
(continued)

**CLEARANCE SALE**

Reclaimed Valves and Tubes. Most comprehensive selection at keenest prices. All valves re-tested before despatch and guaranteed to be in good working order.

1A7	7/6	20P3	6/-	EM1	6/-
1D5	7/6	20P4	10/-	EM34	6/-
1D6	7/6	20P5	6/-	EN31	4/-
1H5	8/-	25Z4	4/-	EY31	4/-
1N5	6/-	30P6	4/-	FC4	5/-
5U4	4/-	30PL1	4/-	KT33C	2/6
6A7	7/6	30P4	10/-	KT36	4/-
6A8	6/-	30P12	4/-	KT61	4/-
6A7B	4/-	30PL1	4/-	KT81	4/-
6A7C	4/-	30	5/-	KTW61	4/-
6B2C	12/6	185BT	10/-	KTW63	4/-
6BQ7A	5/-	5763	6/-	MHD4	5/-
6C4	2/6	DAC33	6/-	MUI2	5/-
6CH6	6/-	DF32	6/-	N37	4/-
6F14	4/-	DK38	7/6	OM4	4/-
6F15	4/-	DL28	7/6	OM10	6/-
8J6	4/-	EAC91	2/6	PCC84	4/-
6J7	4/-	EBC3	6/-	PCF80	4/-
6K8	6/-	EBC33	4/-	PCL82	4/-
6K25	6/-	EBF90	4/-	PCL83	4/-
6L4	6/-	ECC33	2/6	PC4	5/-
6L8	6/-	ECC34	2/6	Pen 45	4/-
6L18	4/-	ECC81	2/6	PL33	2/6
6N7	6/-	ECC82	4/-	PL38	10/-
6S37	4/-	ECC83	4/-	PL81	4/-
6SK7	4/-	ECC85	5/-	PL82	4/-
6SL7	4/-	ECC86	5/-	PL83	4/-
6SN7	2/6	ECC98	5/-	Py21	4/-
6U4	6/-	ECC91	4/-	Py20	4/-
630L2	6/-	ECF80	5/-	Py81	4/-
7B7	5/-	ECF82	5/-	Py82	4/-
7C2	6/-	ECH36	6/-	Py83	4/-
10P13	4/-	ECL80	4/-	PZ30	4/-
10P14	4/-	EP39	2/6	T41	4/-
12A77	2/6	EF42	2/6	TDD4	5/-
12AU7	4/-	EF92	4/-	U2	5/-
12AX7	4/-	EP96	4/-	U24	7/6
12BH7	4/-	EK2	6/-	U35	4/-
12E1	6/-	EK32	4/-	U191	7/6
12K8	6/-	EL33	4/-	U281	4/-
12SN7	4/-	EL38	4/-	U403	6/-
20D1	2/6	EL41	6/-	UAF42	4/-
20E2	4/-	EL42	6/-	UB41	2/6
20L1	4/-	EL81	6/-	UCH42	6/-
20P1	4/-	EL80	6/-	UF41	6/-
				UL41	4/-

Please send S.A.E. for Free List of 1000 Valves and terms of Business. All letters S.A.E. please.

"ST. JOHN'S RADIO," Mail Order Dept. 3 Jews Row, London SW18. Tel.: VAN 8822

**FOR SALE**

**VALVE CARTONS** at keen prices. Send 1/- for sample and list. J. & A. BOXMAKERS, 75a Godwin Street, Bradford 1.

**100 BAYS** of brand new Adjustable Steel Shelving, 73in. high by 34in. wide by 12in. deep. Stove Enamelled dark green. Sent unassembled. Six shelf bay—£3/15/-. Sample delivered free. Quantity discounts. N. C. BROWN LTD., Eagle Steelworks, Heywood, Lancs. Tel.: 69018.

**METAL RECTIFIERS**

**RECTIFIERS—CONTACT COOLED**  
14RA1282 (FC101) type 250 v., 250 mA, 13/6;  
14RA1283 (FC31) type 250 v., 300 mA, 17/6;  
350 mA, 19/6; EC1 13/-.  
**RECTIFIERS—FINDTYPES**  
Equivs. for RM4 250 v., 250 mA, 13/6; RM6 250 v., 300 mA, 17/6; 14A989 400 mA, 18/6;  
14A80 16/6; 14A97 19/-; 14A100 22/6; 14A124 19/6; LW7 17/6; LW15 20/-; EK0 20/-.

**MULTIMETERS 54/-**  
FROM

**CASY M1**, 13 ranges, £2.14.0; A10, 16 ranges' £4.17.6; B20, 30 ranges, £6.10.0; 200 H' £0.000 ohms per volt, £2.18.6.  
Stamped envelope for full details and bargain offers.  
Under £1 P. & P. 6d., over £1 Post Free. C.O.D. 2/6.

**DURHAM SUPPLIES**

175 Durham Road, Bradford 8, Yorkshire

**FOR SALE**  
(continued)

**ST HELENS 4246. DARWINS** for Rebuilt Tubes, delivered, £4/10/-.

**BARGAIN OFFER!**

**14in. TELEVISIONS B.B.C. and I.T.A. IN WORKING ORDER EX-RENTAL Famous Manufacture £4.19.6**

Carriage extra 15/- C.W.O.

**CAPITAL TV**

**55 HONOR OAK PARK FOREST HILL, S.E.23.**

**1,000 TELEVISIONS**, all makes, from £3 working, 10/- not. Callers only. 9 till 6, including Sats. 39 Whitehorse Lane, Stepney, London.

**Star TV Tubes**  
**70/-**

all sizes up to and including 17in. include old glass, or plus 7/6 without

C.W.O. Carriage 7/6

**WHY PAY MORE**

new guns, 12 months' guarantee

also 20/- each

12in. 14in., Part Exchange Televisions. Callers only

**ARTHUR SLARK**

43-45 Thicketford Road, Tonge Moor, Bolton  
Phone: 26684

**WANTED**

**WANTED: NEW VALVES** and Transistors, any quantity. S. N. WILLETS, 43 Spon Lane, West Bromwich, Staffs. Tel: WES 2392.

**A PROMPT CASH OFFER** for your surplus brand new Valves and Transistors. R.H.S., Beverley House, Mannville Terrace, Bradford 7.

**WANTED—New Valves** and Transistors, any quantity.—Phone: Cherrywood 3955, D. & B. Television, 131 & 131a Kingston Road, South Wimbledon, SW19.

**NEW VALVES WANTED** — EY51, ECL80, PCC84, PCF80, PCL93, PL81, PCL82, PY81, R19, U801, 30P4, etc. Best cash prices by return. DURHAM SUPPLIES, 175 Durham Road, Bradford 8, Yorks.

**SERVICE SHEETS**

**WHY TOLERATE DELAY** when we can supply your Radio or TV Service Sheet by return of post at 4/- each, plus postage. List 1/-. Also Manuals for sale and hire. List 1/-. S.A.E. with inquiries please. Mail orders only to S.P. DISTRIBUTORS, 44 Old Bond Street, London, W1.

**SERVICE SHEETS** (30,000), 3/- each with S.A.E. DARWIN, 19 George St., St. Helens, Lancs.

**SERVICE SHEETS**  
(continued)

**GENUINE S/SHEETS** for Hire. Radio/TV/T. Recorders. S.A.E. to: REDWATT TUBE DISTRIBUTORS, 41 Denmark Street, Wakefield, Yorks.

**SERVICE SHEETS**, Radio, TV, 5,000 models. List 1/-. S.A.E. enquiries.—TELRAY, 11 Maudland Bk, Preston.

**SERVICE SHEETS**

For all makes of Radio and Television—1930-1962. Prices from 1/-. Free fault-finding guide with all Service Sheets. Please send S.A.E. with enquiries. Catalogue of 6000 models. 1/6.

Special offer of 125 Radio/TV Sheets covering many popular models, 20/-.

**HAMILTON RADIO**

Western Road, St. Leonards, Sussex

**SERVICE SHEETS**; also Current and Obsolete Valves for sale. JOHN GILBERT RADIO, 20 Extension, Shepherd's Bush Market, London W12. (Phone: SHE 3052).

**SERVICE SHEETS**, Radio and TV 4/- each. List 1/-. All orders dispatched on day received. Also manuals for sale and hire. List 1/-. S.A.E., please. SULTAN RADIO, Pantiles Chambers, Tunbridge Wells, Kent.

If TV is your LIVING OR PLEASURE you cannot afford to be without

**ESSENTIAL SERVICING DATA**  
TV 10/6 RADIO 13/6

Major items of hundreds of sets listed also

**TELEVISION SERVICING HANDBOOK 30/-**

Learn to clear TV faults quickly and SAVE POUNDS  
Fault Charts pin-point trouble spots — Don't delay order today —

Return of post from  
GORDON J. KING  
KINGSFORD, SOUTH FURZEHAM RD  
BRIXHAM, Devon.

**FAULTFINDER FILES**, showing common faults that each receiver is prone to and other useful servicing information, 2/- each. List 9d, plus postage. Mail orders only. S.P. DISTRIBUTORS, 44 Old Bond Street, London W1.

**TV SERVICE SHEETS** with Free advice, 3/6 each. ADAMS, 79 Birmingham St., Halesowen, Birmingham.

**BOOKS & PUBLICATIONS**

**FIND TV SET TROUBLES** in minutes from the great book "The Principles of TV Receiver Servicing". 10/6 all book houses and radio wholesalers. If not in stock from Secretary I.P.R.E., 20 Fairfield Rd., London N8.

**MISCELLANEOUS**

**MUSIC and MUSICAL ACCESSORIES** Catalogue 1/-. Agents wanted.—Darwins, 19 George Street, St. Helens, Lancs.

**EDUCATIONAL**

"HOW AND WHY" of Radio and Electronics made easy by a new non-maths practical way. Postal instructions based on hosts of experiments and equipment buildings carried out at home. New courses bring enjoyment as well as knowledge of this fascinating subject. Free brochure from Dept 12, P.T. RADIOSTRUCTOR Reading.

**THE INCORPORATED Practitioners** in Radio and Electronics (I.P.R.E.), Ltd. Membership Conditions booklet 1/- Sample copy of I.P.R.E. official journal 2/- post free. Secretary, 20 Fairfield Road, London N8.



By repairing Radio and TV Sets as a job or as a spare time business. Our practical course will show you the way. No previous experience is required.

**SEND FOR FREE BOOK TODAY!**

**RADIOSTRUCTOR**  
Dept. G78 READING, BERKS

**ALUMINIUM, LIGHT ALLOYS BRASS, COPPER, BRONZE**

IN ROD, BAR, SHEET, TUBE STRIP WIRE, ANGLE, CHANNEL, TEE

**3,000 STANDARD STOCK SIZES**

**H. ROLLET & CO. LTD.**  
6 CHESHAM PLACE, LONDON, S.W.1  
BELGRAVIA 4300

**Works:**  
36 ROSEBERY AVE., LONDON E.C.1

Branches at Liverpool, Manchester, Birmingham, Leeds  
No Quantity too small

**TUBES**  
All types  
**12"-17" ONLY 30/-**

**WHY PAY MORE?**

These tubes are ex rental stocks, each one fully tested before despatch. Guaranteed to give excellent results, and complete satisfaction, or money refunded. Please state type required, or Model No. of set, and name of nearest railway station.

Carr. 10/- extra.

**SEND NOW WHILE STOCKS LAST TO**  
**REGENT SUPPLIES Dept. P.T.**  
124 Athelstan Rd., Southampton

**ALL THE FACTS, FIGURES AND DATA YOU NEED**

- Broadcasting
- Communications
- Navigation
- Servicing

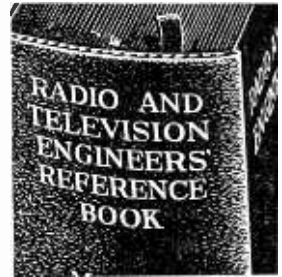

(Editor) J. P. HAWKER  
(Advisory Editor) W. E. PANNETT, A.M.I.E.E.

Here is an opportunity for you to study this practical engineering and servicing work without charge. It provides in easy-reference form a wealth of information, not readily obtainable elsewhere.

Formulae & Calculations. Electron Optics & Colour TV, Materials, Studios & Equipment—planning, lighting, camera tubes, etc. Communication Transmitters—design, components, marine, ground-to-air, mobile, etc. Amateur Radio Equipment. R. F. Transmission Lines. Wave-guides. TV Receiver Design. Commercial H.F. Radio Links. Broad-Band Radio Systems. Navigation & Radar. Aero Equipment—aerials, approach and landing aids, Doppler, etc. Aerials. Crystal Diodes. Resistors. Capacitors. Inductors & Transformers. Microphones. Loudspeakers. Interference. Tape Recorders. Gramophone Mechanisms. Batteries & Conversion Equipment. Radio & TV Installation & Servicing. Units & Symbols, etc.

**47 SPECIALIST CONTRIBUTORS**

including experts from—Aerialite, B.B.C., B.T.H., Decca, Derwent, E.M.I., Ever Ready, G.E.C., Garrard, H.M.V., Marconi, Murphy, Plessey, Pye, Siemens Bros., Standard Telephones & Cables, Valradio, Westinghouse, and many others.

**Over 1,800 pages**

**2,000 DIAGRAMS, CIRCUITS, TABLES, CALCULATIONS FORMULAE, DRAWINGS AND PHOTOGRAPHS.**

**IT'S YOURS**  
**FREE**  
**FOR 7 DAYS!**

**SEND NOW! NO OBLIGATION TO BUY**

George Newnes Ltd., 15-17 Long Acre, London, W.C.2.

Please send me Newnes RADIO AND TELEVISION ENGINEERS' REFERENCE BOOK without obligation to purchase. I will either return the work within eight days or I will send the first payment of 5/- eight days after delivery, then ten monthly subscriptions of 10/- until the sum of £5. 5s. has been paid. Cash in eight days is £5.

(Tick  where applicable)

The address below is:—My Property  Rented unfurnished   
Furnished Accommodation  Temporary Address  Parent's Home

**BLOCK LETTERS BELOW PLEASE**

Mr., Mrs., Miss \_\_\_\_\_

Full Address \_\_\_\_\_

Occupation \_\_\_\_\_

Your Signature \_\_\_\_\_  
(Parent signs if you are under 21).

(RB) 538/10

This coupon is invalid if not signed and all questions answered

# REBUILT TUBES!

You're safe when you buy from  
**RE-VIEW LTD!**



- ★ Each tube is rebuilt with a completely new gun assembly and the correct voltage heater.
- ★ Each tube comes to you with a guarantee card covering it for a year against all but breakage.
- ★ Each tube is delivered free anywhere in the U.K. and insured on the journey.
- ★ Each tube is rebuilt with experience and know-how. We were amongst the very first to pioneer the technique of rebuilding television tubes.

## HERE IS WHAT YOU PAY:

12in. ... ..	£4.10.0
14in. ... ..	£4.15.0
15in. ... ..	£5. 0.0
17in. ... ..	£5. 0.0
21in. ... ..	£7. 0.0

Cash or cheque with order, or cash on delivery

## RE-VIEW (LONDON) LTD.

385 LONDON ROAD, WEST CROYDON, SURREY. TEL. THORNTON HEATH 7735.

# FREE TO AMBITIOUS ENGINEERS

— THE LATEST EDITION OF ENGINEERING OPPORTUNITIES

**Have you sent for your copy?**  
ENGINEERING OPPORTUNITIES is a highly informative 156-page guide to the best paid engineering posts. It tells you how you can quickly prepare at home for a recognised engineering qualification and outlines a wonderful range of modern Home Study Courses in all branches of Engineering. This unique book also gives full details of the Practical Radio & Electronics Courses, administered by our Specialist Electronics Training Division—the B.I.E.T. School of Electronics, explains the benefits of our Employment Dept. and shows you how to qualify for five years promotion in one year.

**We definitely Guarantee**  
**"NO PASS — NO FEE"**

Whatever your age or experience, you cannot afford to miss reading this famous book. If you are earning less than £25 a week, send for your copy of "ENGINEERING OPPORTUNITIES" today—FREE.

**BRITISH INSTITUTE OF ENGINEERING TECHNOLOGY** (Incorporating E.M.I. Institutes)  
(Dept. SE/20), 29 Wright's Lane, London, W.8

### WHICH IS YOUR PET SUBJECT?

Mechanical Eng.,  
Electrical Eng.,  
Civil Engineering,  
Radio Engineering,  
Automobile Eng.,  
Aeronautical Eng.,  
Production Eng.,  
Building, Plastics,  
Draughtsmanship,  
Television, etc.

**GET SOME LETTERS AFTER YOUR NAME!**

A.M.I.Mech.E.  
A.M.I.C.E.  
A.M.I.Prod.E.  
A.M.I.M.I.  
A.I.O.B.  
A.F.R.Ae.S.  
B.Sc.  
A.M.Brit.I.R.E.  
City & Guilds  
Gen. Cert. of Education  
Etc., etc.

### PRACTICAL EQUIPMENT

Basic Practical and Theoretic Courses for beginners in Radio, T.V., Electronics, Etc., A.M.Brit.I.R.E. City & Guilds Radio Amateurs' Exam. R.T.E.B. Certificate P.M.G. Certificate Practical Radio Radio & Television Servicing Practical Electronics Electronics Engineering Automation

### INCLUDING TOOLS!

The specialist Electronics Division of B.I.E.T. (Incorporating E.M.I. Institutes) NOW offers you a real laboratory training at home with practical equipment. Ask for details.

**B.I.E.T. SCHOOL OF ELECTRONICS**



### POST COUPON NOW!

■ Please send me your FREE 156-page "ENGINEERING OPPORTUNITIES"  
■ (Write if you prefer not to cut page)

■ NAME.....  
■ ADDRESS.....

■ SUBJECT OR EXAM THAT INTERESTS ME..... (SE/20).

**THE B.I.E.T. IS THE LEADING ORGANISATION OF ITS KIND IN THE WORLD**



