

PRACTICAL TELEVISION

AND TELEVISION TIMES

1½

EDITOR
F. J. CAMM

A NEWNES PUBLICATION

Vol. 2 No. 18

NOVEMBER 1951



FEATURED IN THIS ISSUE

A Versatile Pre-Amplifier
Afterthoughts on the Show
Latest Television News

Servicing Television Receivers
Design of Video Stages
Converting the R.D.F.I.



CLEAR PICTURES in "poor reception" areas

The models 63 and 63A have been designed for maximum performance in fringe and difficult reception areas. Since the reception of your TV receiver is wholly dependent on the efficiency of the aerial system, the Aerialite features of greater gain, broader bandwidth and sharper directivity are very worthwhile. There is every reason why you should specify Aerialite for your TV aerial if you wish to ensure strong, clear and interference-free pictures. The models 63 and 63A are priced at £11.15.0 and £12.5.0 respectively, complete with 10ft. masts, lashings, etc. Models with 14ft. masts are available at 17/- extra. Aerialite are manufacturers of a comprehensive range of TV and radio aerals as well as coaxial and R.F. cables.

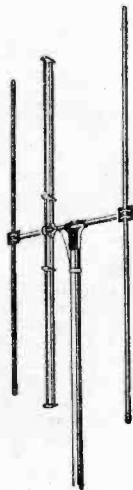

Aerialite LTD.

CASTLE WORKS STALYBRIDGE CHESHIRE

RADIO MAIL

74 MANSFIELD ROAD, NOTTINGHAM

METER RECTIFIERS. These are genuine bridge type, 5/-.

LENGTHS CO-AXIAL CABLE. 70 ohms. With Pye plugs each end. Brand new at only 8/- per coil, post paid. Also 10ft. lengths with Pye plugs each end, unrepeatable at 2/-.

THERMOSTATS. Tubular glass enclosed type with connections at the top. Heavy contacts opening at 50 deg. F., plus or minus 10. 2/3 each, post paid.

HEATER TRANSFORMERS. 6.3 volts, 3 amps., 230 volt mains input. Robust Admiralty type, with 2,000 volt insulation. Weight 3 1/2 lbs. Size 3 x 2 1/2 x 4 ins. high. Note that 3 amps. is the Admiralty rating. Will deliver considerably more without overloading. 9.9 post paid.

EX-GOVT. VALVES, NEW, BOXED. EFS0 6.6; SP61, 3.3; EA50, 2.3; VRI16, 2/-; EB34, 2.3; VP23, 5.6; HL23DD, 5.6; ATP4, 2/9. Also valves ex equipment, guaranteed. EFS0, 3.9; SP61, 2.3.

RECEIVERS, TYPE 3584. Brand new, less valves and "Pye" strip. Component stripping value of at least £10. Good length of wire ends on the hundreds of resistors, etc. Also included are multi-contact relays, tropicalised pots, gear box, motor, drive and dial. In metal case 20 x 13 x 7 ins., 28.6, plus 5/- carriage.

CONTROL UNITS, TYPE 488. In metal box, 9 x 5 x 4 1/2 ins., containing 4 potentiometers, wafer and toggle switches, resistors, condensers, knobs, etc. Brand new at 4.6, post paid.

COLVERN WIRE-WOUND POT'S. 25,000 ohms, 1.9.

TUBULAR CONDENSERS. Cardboard type, wire ends. 1 mfd., 350 volts. New, in boxes, at 2.9 per dozen.

MINIATURE VARIABLE CONDENSERS. Long fin. spindle, ceramic insulation, 30 pf, 1.9.

SCREENED A.F. CHOKES. For scratch filters, etc., 3.6.

CALLERS TO 4, RALEIGH STREET.

STAMP WITH ALL ENQUIRIES PLEASE.

The solder for all HOME TELEVISION CONSTRUCTOR SETS

Designers of television constructor sets know that the efficiency of their equipment depends on the solder used by the constructor—that's why they recommend Ersin Multicore for trouble-free, waste-free soldering. Ersin Multicore, the only solder containing three cores of extra-active, non-corrosive Ersin Flux, is obtainable from all leading radio shops. Ask for Cat. Ref. C.16018, 18 S.W.G. 60 40 High Tin Television and Radio Alloy. The size 1 Carton contains 37 feet of solder, costs 5/-.



Ersin Multicore Solder

In case of difficulty in obtaining supplies, please write to:

MULTICORE SOLDERS LTD.,

MELLIER HOUSE, ALBEMARLE STREET, LONDON, W.1 • R:Gent 1411

23,759 MODEL A ENVELOPES SOLD +
29,438 MODEL B ENVELOPES SOLD +

MODEL C FOR

HOLME MOSS
now available!

Join the select band of radio amateurs who have built their own Television Receiver. It's a wonderful hobby—a real thrill for you and long-lasting pleasure for the whole family when completed.

The 'View Master' has been specially designed by a leading Television Engineer to give the highest standard of performance with exceptional simplicity in wiring and layout. Assembled in six easy stages, it can be built by anyone who can read a wiring diagram and use a soldering iron.

Constructor Envelope now available contains full size wiring diagrams with 36 page booklet for building and operating the 'View Master.'

Price 5/- from any Wireless Shop or 5/6, post free, from George Over (Rugby), Ltd., Rugby.



★ 'View Master' parts are being manufactured in ever-increasing numbers to meet the big demand

—the most popular home-constructor T.V.

THE *New* WINDSOR Television **WOBBULATOR**

MODEL 260A

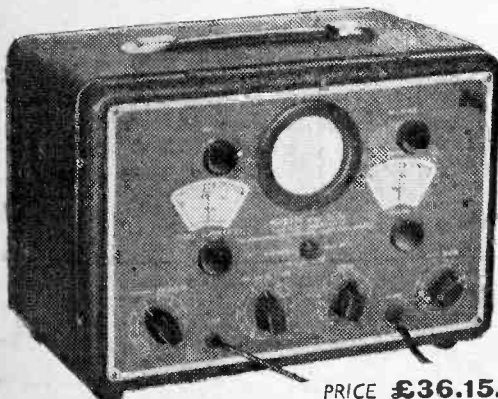

The first self-contained electronic instrument providing visual alignment facilities for television receivers. Simple, compact and efficient—its use will save many hours of valuable time in the service department.

FEATURES

- CARRIER FREQUENCY. 5-70 Mc/s. 10-140 Mc/s (on 2nd harmonic).
- BANDWIDTH. 0.5 Mc/s total. 0-10 Mc/s (on 2nd harmonic).
- SWEEP FREQUENCY. 50 c.p.s. sinusoidal, return trace blacked out automatically.
- OUTPUT. Adjustable from 0-10 mV. approx. Fixed and variable attenuators are fitted. Output impedance 75 ohms.

PRICE **£36.15.0** LIST

EARLY DELIVERY. Please write for further details and information on other WINDSOR and TAYLOR products.

TAYLOR ELECTRICAL INSTRUMENTS LTD.
 419/424 MONTROSE AVENUE, SLOUGH, BUCKS
 Telephone: SLOUGH 21381 (4 lines). 'Grams & Cables: Taylins, Slough



MODEL 260A TELEVISION WOBBULATOR MODEL 260A TELEVISION WOBBULATOR



CONDENSERS

The abbreviated ranges of two popular types given here are representative of the wide variety of T.C.C. Condensers available.

'VISCONOL CATHODRAY'

Cap. Range: .0005mfd. to 1 mfd.
Voltage Range: 750 to 25,000 at 60°C.

Cap. in μ F.	Max. W/kg. at 60°C.	Dimens. (Overall)		Type No.
		Length	Dia.	
.0005	25,000	5 $\frac{1}{8}$ in.	1 $\frac{1}{2}$ in.	CP.57.HOO
.001	6,000	2 $\frac{1}{2}$ in.	$\frac{3}{8}$ in.	CP.55.QO
.001	12,500	3 in.	1 $\frac{1}{8}$ in.	CP.56.VO
.01	6,000	3 in.	1 $\frac{1}{2}$ in.	CP.56.QO
.1	7,000	6 $\frac{1}{2}$ in.	2 in.	CP.58.QO
.25	5,000	5 $\frac{1}{8}$ in.	2 $\frac{1}{8}$ in.	CP.59.MO

Regd.

MOULDED MICA CONDENSERS

Stacked Foil. Capacities from 50 to 10,000 pF
Voltage Ratings, 350 to 2,500 v. D.C. Working.

MOULDED SILVER MICA CONDENSERS

Capacities from 10 to 10,000 pF.
Voltage Ratings, 350 v. D.C. Working.

WAX PROTECTED SILVERED MICA CONDENSERS

Capacities from 5 to 12,000 pF.
Voltage Ratings, 350 v. D.C. and 750 v. D.C. Working.

THE TELEGRAPH CONDENSER CO. LTD.

Radio Division: North Acton, London, W.3. Tel: Acorn 0061

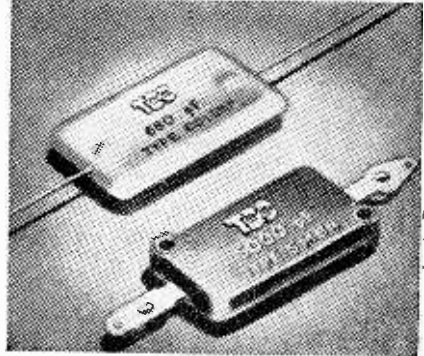
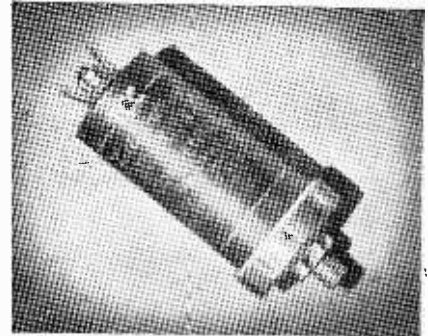

• A speaker for the constructor's every need

Type	Cone dia.	Flux Density (Gauss)	Pole dia.	Gap length	Flux face	Total Flux	Speech coil Impedance (Ohms)	Handling Capacity (Watts)	PRICES	
									With Trans. £ s. d.	Without Trans. £ s. d.
*S.2.57	2 $\frac{1}{2}$ "	7,000	.375"	.033"	.093"	5,285	3	.3	—	18 6
*S.3.57	3 $\frac{1}{2}$ "	7,000	.625"	.035"	.125"	11,500	3	2	—	19 6
S.507	5"	7,000	.75"	.040"	.125"	14,000	3	2.5	1 8 9	1 1 0
*S.607	6"	7,000	.75"	.040"	.125"	20,000	3	3	1 11 9	1 2 6
S.607	6"	7,000	.75"	.040"	.125"	20,000	3	3	1 13 9	1 4 6
S.810	8"	10,000	1"	.043"	.187"	39,500	3	5	2 3 0	1 12 6
S.912	9"	12,000	1"	.043"	.187"	47,400	3	7	2 7 3	1 16 9
S.1012	10"	12,000	1"	.043"	.187"	47,400	3	10	3 3 0	2 4 6
S.12135	12"	13,500	1.5"	.050"	.25"	106,000	15	15	10 0 0	9 0 0

Further details of these speakers and of the famous Concentric-Duplex models gladly sent on request.

* All chassis material is of Mazak 3 except those marked with an asterisk which are of Drawn Steel



LOUDSPEAKER CHASSIS

WHITELEY ELECTRICAL RADIO CO. LTD · MANSFIELD · NOTTS

PRACTICAL TELEVISION

& "TELEVISION TIMES"

Editor: F. J. CAMM

Editorial and Advertisement Offices: "Practical Television," George Newnes, Ltd., Tower House, Southampton Street, Strand, W.C.2. Phone: Temple Bar 4363. Telegrams: Newnes, Rand, London.

Registered at the G.P.O. for transmission by Canadian Magazine Post.

Vol. 2. No. 18

EVERY MONTH

NOVEMBER, 1951

TelevIEWS

Encourage Experimenters

IN our June issue we entered a strong plea for a regular television transmission intended for technicians, experimenters and amateurs. Since that time pressure has been brought to bear on the BBC for the transmission of Test Card "C" to be radiated for a quarter of an hour period on two evenings each week. The reaction of the BBC to this eminently sensible suggestion is hardly that which should be associated with the department of the BBC which ought to be anxious to encourage scientifically-minded people to experiment with television. They have turned the suggestion down, on the specious grounds that it would cause interference with rehearsal arrangements, would involve additional expenditure in electricity, result in requests for salary adjustments and possible union activities.

Those who have augmented our efforts in print, and behind the scenes, to get this experimental transmission started feel that amateurs should be encouraged, because in the event of a national emergency they would form the nucleus of our electronic and radio forces.

The trade itself is well catered for in the provision of the transmission of Test Card "C" from between 10 a.m. and noon. No television receiver can be correctly adjusted without use of Test Card "C," or alternatively a video generator. Every manufacturer possesses this equipment and, therefore, does not need Test Card "C" transmissions.

We have pleasure in lending our support to this move, especially as it is part of our function to publish designs of television receivers for construction by experimenters. We urge our readers to take immediate action by writing to the BBC on the subject.

NEXT MONTH—HOLME MOSS FEATURES

NOW that the Holme Moss is in operation television is brought within the scope of several million more viewers, who will be seeking information on the choice of a receiver, erection of aerials, the problem of the fringe areas and on television problems generally.

Special features, therefore, will be included in next month's issue for those living in the Holme Moss area. Details will be included for the construction of a cheap television receiver, costing no more

than £9. All readers having television problems are invited to submit them to us for solution. We shall include an article on how to modify existing receivers, as well as our own "P.T." receiver to receive the Holme Moss transmission. There will be a summary of the specifications of commercial receivers.

NEARLY ONE MILLION

AN analysis of the licence figures shows that about 175,000 people are operating television receivers without paying the £2 licence fee. According to the trade at least 1,100,000 television sets are in operation. They have produced 1,200,000 sets since the war and at least another 150,000 have been built by amateurs. The total number of television licences issued to date is 933,050. If everyone paid their £2 licence fee the BBC would have about £200,000 more to use for improvement of programmes and equipment. It is a small enough fee to pay for a whole year's pictorial entertainment.

INDEXES

INDICES for Volume 1, comprising issues dated April, 1950, to May, 1951 (12 issues), are available for 1s. 1d. by post, from the offices of this journal. Those readers wishing to have their copies bound should communicate with Messrs. Hazell, Watson and Viney, 52, Long Acre, London, W.C.2.

MONICA DICKENS TELEVISED

A FEW months ago we felt it necessary severely to criticise Monica Dickens, who is a regular contributor to that influential weekly, *Woman's Own*. She had stated that she disliked television, "wouldn't have one if they gave me one," that it wasted the time of housewives, and caused them to neglect their household duties. It was with some surprise, therefore, that we observed that she is not averse to appearing on the television screen herself, and thus aiding and abetting housewives in neglecting their household duties!

Miss Dickens really should be consistent.

"PRACTICAL TELEVISION" RECEIVER

Will readers please note that we can supply full-size blueprints for this television receiver at 10s. 6d. for three sheets.—F. J. C.

Interference Suppression

SELECTED CIRCUITS AND AN EXPLANATION OF INTERFERENCE AND ITS CURE

By Gordon J. King, A.M.I.P.R.E.

MUCH of the interference to television reception manifests itself as a result of radiation from car ignition systems and electrical domestic appliances, and consists of very short bursts of electrical energy superimposed, in the form of pulses, on the sound and vision signals. These pulses are of short duration, usually less than one micro-second, and are therefore narrow and steep sided. A serious problem is presented by this type of interference, especially in the fringe areas where the ratio of signal to interference is low. The most satisfactory solution to the problem is of course the one which prevents the interference from being radiated in the first place. Suppression of interference at the source is made available by a number of methods and a good deal has been written about it. However, other devices employed at the receiver end have been developed to reduce the effect of this type of interference. The following notes are intended to explain the general mode of operation of such artifices as are applied to the audio and video channels in modern receivers.

The Effect of the Interference Pulse

The interference pulse may be analysed into a wide spectrum of frequencies extending from zero up to a maximum which is dependent on the channel bandwidth, and the effect of this will be seen later. Owing to their characteristics they are unable to pass through the receiver in their original form, but on arriving at the first tuned circuit each interference pulse causes the circuit to "ring" at its resonant frequency, in much the same way as the flyback pulse causes the inductive load in the line output valve to "ring." A train of damped oscillations is thus developed within the tuned circuit, and on passing through the R.F./I.F. amplifiers the following tuned circuits are prompted to oscillate in sympathy at an increased amplitude. The effect of this causes the oscillations to be amplitude modulated at a frequency which is a function of the time taken by the oscillatory train. Interference side bands are thus produced which are integrated by the demodulator

stage in the usual manner; resulting in the characteristic loud staccato bursts from the loudspeaker, and the large unfocused white blobs on the screen of the cathode ray tube.

A Question of Bandwidth

From the above reasoning it will be noted that the secondary product of the interference pulse is of the frequency at which the receiver is tuned, and is therefore untunable. Further, its duration is dependent on the bandwidth of the R.F./I.F. stages and may be approximated by the expression: Duration of virtual pulse (micro-secs.) = $1/\text{R.F./I.F. Bandwidth (Mc/s)}$. From this it may be seen that a reduction of bandwidth will result in extending the time of the virtual interference pulses as applied to the demodulator stage. If we consider a sound R.F./I.F. channel with a bandwidth of, say, 0.2 Mc/s, the virtual interference pulse will last approximately $1/0.2$, or 5 micro-seconds. The pulse time applied to the vision demodulator will of course be much shorter; for a video bandwidth of 5 Mc/s the pulse will last approximately 0.2 micro-seconds. This is one of the reasons why the effect of ignition interference is usually more unpleasant on the sound than on the vision signal, although without a doubt the psychological aspect has quite a large bearing on the case; a level of interference which could be tolerated on the screen of the cathode ray tube may prove very distressing on the sound receiver. Therefore, it is at least advisable to employ sound suppression on a television receiver which may be subjected to such interference.

Sound Interference Suppression

Most interference limiter circuits, whether employed in the sound or vision channels, embody some device for discriminating between the interference pulses and the maximum modulation. In the circuits about to be described the interference pulses are discriminated by the fact that their amplitude is greater than that of the signal

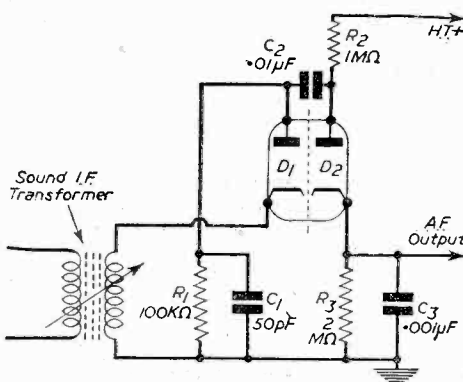

Fig. 1.—A popular circuit for interference suppression on sound.

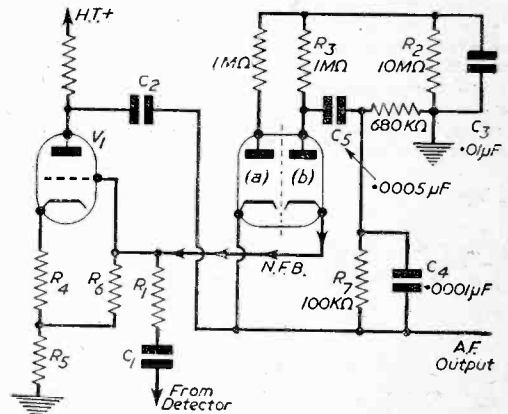

Fig. 2.—Suppressor circuit as used in the sound section of G.E.C. BT 1091.

as represented by 100 per cent. modulation. A biased diode is usually employed for this function arranged to conduct, or cut off, during interference pulses, according to the general design.

A popular method of reducing the interference on sound, and one which is now almost in general use, is shown by the circuit of Fig. 1. The limiting action is performed by a single diode, D2, sometimes a double-

It can be seen, therefore, that all interference pulses, no matter how large they may be, are limited to the above figure. Further, the audio voltage from D2 is usually fairly high, thus the interference pulses reaching the output valve are small in comparison with the desired signal. From the above it is easy to see that it is necessary to keep the duration of the virtual interference pulse as small as possible, by making the bandwidth of the receiver before the limiter as wide as is practicable, for satisfactory differentiation between the interference pulse and the audio signal.

Other Methods

The circuit of Fig. 2 depicts a noise-suppressor circuit as employed in the sound channel of the G.E.C. television receiver Model BT 1091. As will be noted, two diodes are used, and suppression again takes place after detection. The valve V1, being the first A.F. amplifier, is fed from the detector stage via C1, R1. The amplified signal appearing at its anode is conveyed to the output valve via C2 in the normal way. Also in connection with this signal is the cathode of diode (a), the A.F. signal is thus rectified, and a steady D.C. potential is developed across R2 and C3, the diode side of the capacitor acquiring a negative charge. This is applied via R3 to the anode of diode (b). Further, its cathode is also in connection with a positive potential tapped from the potentiometer R4, R5 in the cathode circuit of

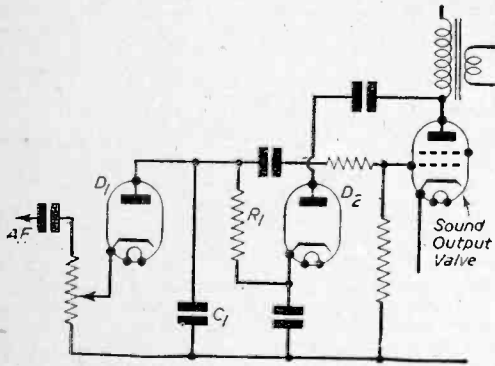

Fig. 3.—Noise limiter circuit by Murphy.

diode valve is used as shown, in which case one of the units D1 is arranged as the sound-detector diode. Resistor R1 constitutes the detector load with capacitor C1 as the by-pass. The negative-going output from the detector is fed via C2 to the anode of D2, which is rendered conductive by the application of a positive potential to its anode via the resistor R2. On the arrival of an audio signal at D2 its anode swings less positive according to the modulation pattern, varying the potential across R3; in fact the variation of potential across R3 is in sympathy with the applied audio voltage at the anode, and so long as the diode is conducting no appreciable distortion will ensue. The audio voltage thus appearing across R3 is conveyed to the output stage.

Now if a short-duration pulse due to interference arrives at the anode of D2 it will cease to conduct, since the interference pulse will have counteracted the applied positive potential, which is pre-adjusted for cut-off on peaks exceeding 100 per cent. modulation; and the potential across R3 will also fall. The rate at which the voltage falls is governed by the time-constant of R3/C3 which may be made reasonably large before serious attenuation of the higher frequencies occurs, and is usually in the region of 2 milli-seconds. Thus a pulse of interference presented to the limiter diode lasting, say, 5 micro-seconds will cause the potential across R3 to fall by only a fraction of a volt, which represents the magnitude of the interference pulse as fed to the output stage.

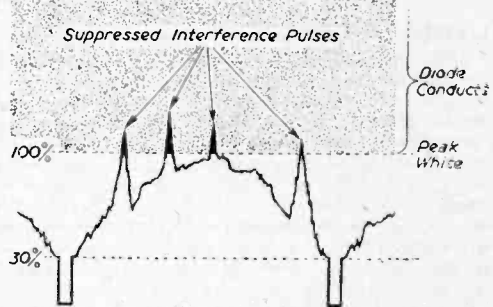

Fig. 4.—This diagram illustrates how interference pulses are clipped off by a conducting diode.

V1 via R6. Diode (b) is, therefore, held well within cut-off, and the A.F. signal transmitted to its anode via R7, C4 and C5 is insufficient to allow the valve to conduct. Short-duration interference pulses superimposed on the A.F. signal, however, will tend to counteract the combination of bias potentials applied to the diode rendering it conductive, since, as before, the circuit constants are so arranged as to prevent the valve from conducting until a pulse representing greater than 100 per cent. modulation is applied to the anode. The time-constant of R2/C3 is made large, approximately 100 milli-seconds, holding the potential across R2 steady during interference pulses, thus preventing variation of the bias applied to the anode of diode (b). Owing to conduction of this diode during bursts of interference a large degree of negative feedback is applied to the grid of V1, with a consequential reduction of interference magnitude fed to the output valve.

A noise-limiter circuit of rather unorthodox design and fitted to the Murphy V114 and V118 receivers, is shown by Fig. 3. The A.F. voltage from the detector/A.F. stage is applied to the cathode of D1 which forms the limiter diode. C1 charges and holds the anode positive, rendering it conductive so long as the time-

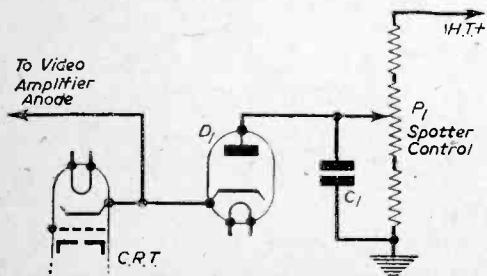

Fig. 5.—A single diode limiter circuit of simple design.

constant $C1/R1$ is longer than the rate of change of the highest audio frequency. A short-duration interference pulse, however, will cause the cathode potential to rise faster than the charging rate of $C1$ and the diode will cease to conduct. Since the ratio of interference voltage to audio voltage varies according to the signal strength, a second diode, $D2$, is employed to rectify the audio voltage appearing at the anode of the output valve. The voltage so derived is used for biasing $D1$. Thus, the limiting action is governed by the loudness of the audio signal. A noteworthy advantage of this circuit is that during quiet intervals a noticeable reduction of interference level is acquired.

Vision Limiter Circuits

A typical video waveform on which are superimposed short-duration interference pulses is shown in Fig. 4. Owing to the characteristic shape of the pulses they could themselves represent white picture elements, and for this reason discrimination between the interference and the desired signal is made exceedingly difficult; however, simple limiting devices provide a satisfactory compromise. As with sound, most video-limiting circuits employ a biased diode for this function. Referring to Fig. 4, the diode is arranged to conduct only when the amplitude of the video signal as represented by 100 per cent. modulation is exceeded by the interference pulse. The interference, therefore, is limited to keep within the 100 per cent. modulation mark, thus ensuring the interference spot on the screen does not exceed peak white, and preventing it from appearing as a large unfocused white blob. It will, of course, be appreciated that should the diode conduct at some lower value than peak white the picture will appear flat, i.e., there will be a loss of detail in the lighter parts of the picture and the contrast ratio will be reduced. For that reason, it is considered advisable in practice to set the bias voltage a little above peak white, this will save constant adjustment of the spotter control should the signal fade, although this will result in a reduction of the effective limiting action.

A single-diode limiter circuit of very simple design is depicted by Fig. 5. Negative-going interference pulses applied to the cathode of the diode render it conductive, and the interference pulses are therefore short-circuited via $C1$. Unfortunately, with this simple method alteration of the contrast setting necessitates readjustment of the bias, or limiter control $P1$. A method whereby the degree of limiting is automatically adjusted according to the signal is shown in Fig. 6. The capacitor $C1$ acquires a charge equal to the voltage of peak white signals, which holds the diode anode negative and non-conducting. On the arrival of a steep-sided interference pulse the charge across $C1$ is unable to follow and the diode conducts. The resistor $R1$ governs the time-constant of the circuit and in some cases is made variable, enabling a compromise to be arranged between maximum suppression and picture quality. This circuit is now

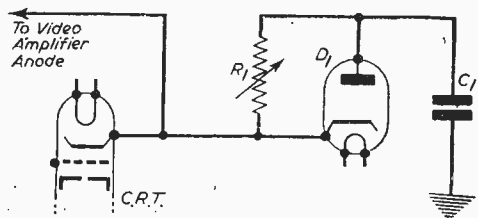

Fig. 6.—In this circuit the degree of limiting is automatically adjusted by the signal.

almost in general use in current receivers. Sometime however, it is modified slightly, i.e., where grid modulation is employed, in which case the sense of the diode is reversed.

Picture Interference Inverter

A circuit developed by the General Electric Co. for inclusion in their television receivers is shown in

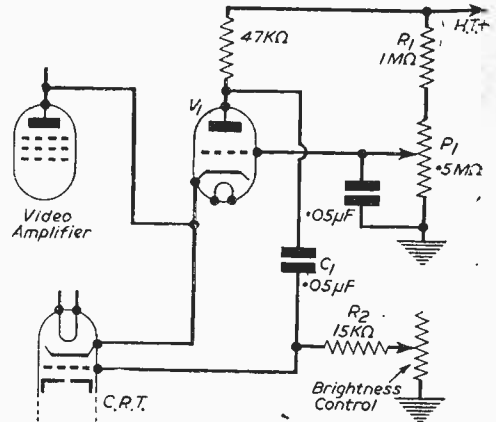

Fig. 7.—A picture interference inverter developed by the G.E.C.

Fig. 7. Its function is to alter the phase of the interference pulse making it appear as a gap, instead of an unfocused white blob, in the picture.

The phase reversal takes place in the triode valve $V1$, which is biased, as in the previous circuits, allowing it to conduct on interference pulses only. Since the positive potential from the anode of the video amplifier is in direct connection with the cathode of $V1$, a positive potential of reduced magnitude will need to be applied to the grid. This is made available by the resistors $R1$ and $P1$, and the negative grid potential, in respect to the cathode, is rendered variable by $P1$. This is adjusted to hold the valve at cut-off except during bursts of interference.

In order to understand the function of this circuit it is first necessary to consider the phase of an interference pulse in relation to the cathode and grid of the picture tube. As the tube is cathode modulated the pulse at the cathode will be negative going, or positive going at the grid, and included in the grid circuit is a resistor $R2$ across which the positive-going pulse will be developed. Further, the grid of $V1$ will go positive in respect to its cathode and the valve will conduct; the anode will go negative and the pulse will be transmitted via $C1$ to the grid of the picture tube. Therefore, this electrode will receive two out-of-phase pulses, and so long as they are of equal amplitude they will cancel out leaving a small gap in place of the normal white spot on the picture.

TWO NEW EDITIONS

"PRACTICAL WIRELESS" CIRCUITS
15th Edition

WIRELESS COILS, CHOKES & TRANSFORMERS
8th Edition

6/- or 6/6 by Post from

GEORGE NEWNES, LTD., Tower House,
Southampton Street, Strand, London, W.C.2.

A VERSATILE PRE-AMPLIFIER

AN ADD-ON UNIT FOR EXISTING RECEIVERS

By Gordon J. King

WITH the opening of the Holme Moss television transmitter an increased demand will arise for a pre-amplifier designed for that channel, since obviously the so-called fringe area will become greatly extended. Further, other channel "fringe viewers" who have been using their receivers more or less "flat-out" over the last 12 months or so may now find the sensitivity is not what it was owing to the gradual fall off of valve emission, etc. For these viewers, in particular, the pre-amplifier to be described should be of interest; and enable them to obtain better reception for the minimum cost.

The pre-amplifier was initially designed to fit into a small tobacco tin and embodying its own power unit. This method of construction facilitates fitting of the unit to the inside of the receiver cabinet, and also solves the power problem where the receiver may be of the A.C./D.C. technique; thus enabling the unit to be installed without the necessity for receiver modification. However, there is no reason why the H.T. and L.T. supplies cannot be derived from the power supply of the receiver if it is convenient, thereby showing a marked reduction in constructional cost. Most A.C. type of receivers are able to supply the extra 15 mA. or so H.T. current and the 300 mA. of L.T. current required for the pre-amplifier, without any ill effect.

The Circuit

As will be noted (see page 248) the circuit is quite conventional, bar perhaps the power pack. However, the gain of this single valve unit should check at not less

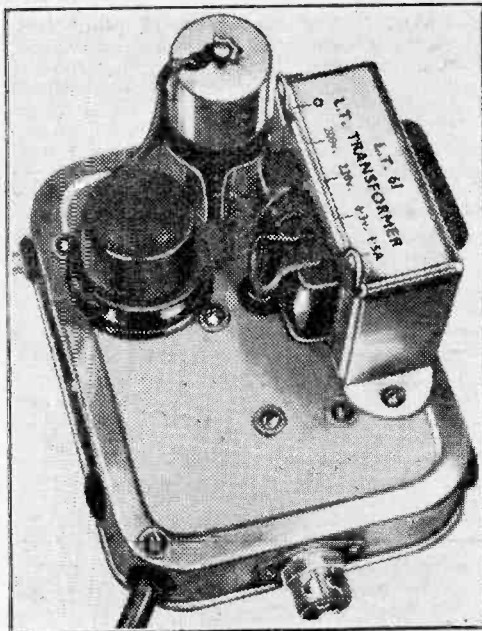

The completed unit.

than 15 db, which, as will be appreciated, is sufficient to make a poor picture good without magnifying the valve noise by any marked degree. The sensitivity of the receiver will thus be increased by a worthwhile amount and at the same time the picture will remain comparatively clean. Another advantage of a single valve amplifier is its freedom from instability, the construction is therefore rendered more flexible.

The circuit shows that the signal is fed to a suitable impedance point on L1, via the aerial isolating capacitor C1, which is necessary since the negative line may be at mains potential although the chassis proper is isolated by C5. In order to obtain the requisite pass-band the grid and anode coils are damped by resistors R1 and R2 of a value dependent on the desired channel (see list of components). The amplified signal is conveyed from a tapping on L2, via the D.C. blocking capacitor C3, to a length of coaxial cable suitably terminated for connection to the receiver. The power pack utilises a small metal type 6H6 valve for rectification, many of which are obtainable from the ex-government market. The mains input is applied to both of the anodes, via the safety resistor R6, it is therefore working as a half-wave device. A 6H6 so employed is overrun, but so far the writer has experienced no dire effect due to this, even though several models have been in use for quite a number of months. If it is considered too much of a risk to use such a valve in this

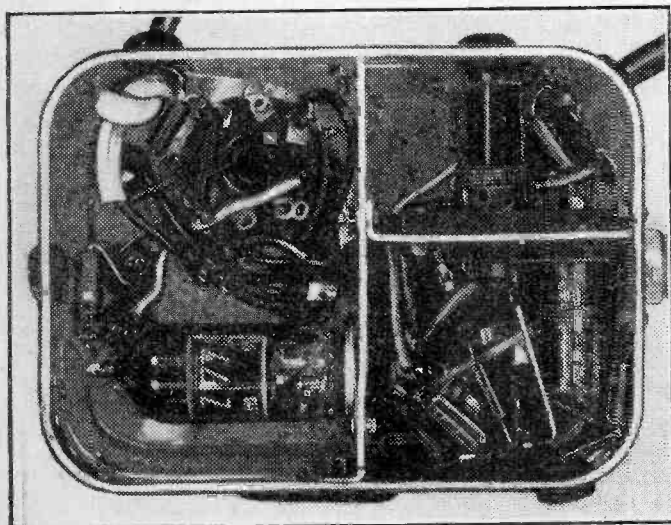

Underside view of the unit showing wiring and coil layout.

position the 6X5 valve is quite suitable and working well within its limits, but unfortunately not so easily acquired from ex-government sources.

The Coils

The coils are wound on Aladdin formers of $\frac{3}{8}$ in. diameter and use standard cores. Winding commences $\frac{1}{4}$ in. from the base of the former using 30 S.W.G., d.c.c. wire. Both coils are close wound and tapped at 1.5 turns from the earthy end.

Alexandra Palace (channel 1)

- L1—7 turns.
L2—6.5 turns.

Holme Moss (channel 2)

- L1—6.25 turns.
L2—5.75 turns.

Sutton Coldfield (channel 4)

- L1—5 turns.
L2—4.5 turns.

Constructional Details

The chassis is produced from a two oz. St. Julien

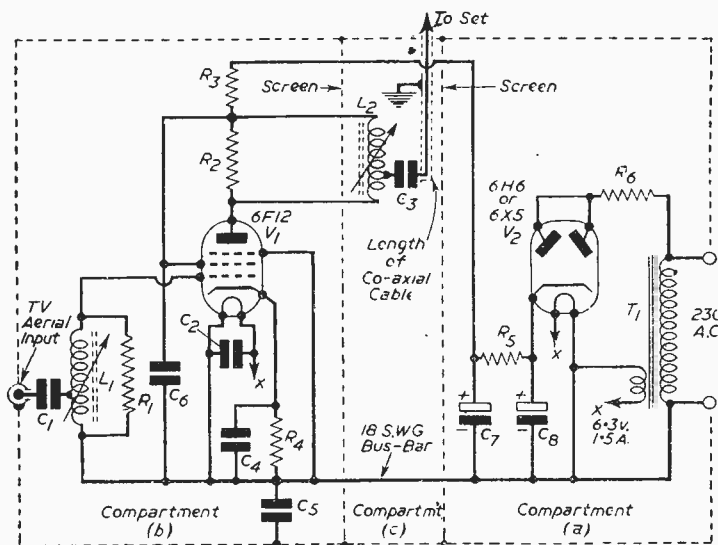

Theoretical circuit of the unit.

LIST OF COMPONENTS

For Channel 1

R1*—3.3K Ω

R2*—2.2K Ω

R3*—6.8K Ω

R4*—120 Ω

R5—1K Ω $\frac{1}{2}$ watt.

R6—100 Ω .

Resistors all $\frac{1}{2}$ watt unless otherwise indicated.

C1*, C3*, C5. Hunts Midget Moldseal Type W99, 0.001 μ F 300 volt A.C. working.

C2*, C4*, C6. Hunts as above, 350 volt D.C. working.

C7/C8, Hunts or T.C.C. "Dry Electrolytic" 8-8 μ F Miniature 250 volt.

Two Aladdin $\frac{3}{8}$ in. coil formers with cores.*

Length of Co-axial Cable.*

One I.O. Valveholder.*

One B7G Valveholder.*

One B/L Co-axial Socket 1.604 S.*

T1, Midget Heater Transformer, 6.3 volt 1.5 Amp.

V1, Mazda 6F12 valve.*

V2, 6H6 or 6X5 valve.

Five 3-way Tag Strips (to be cut to size).*

One 2oz. St. Julien Tobacco Tin.*

N.B.—Components marked * thus required for amplifier less power unit.

For Channel 2

R1*—4.7K Ω

R2*—3.3K Ω

R5—1K Ω $\frac{1}{2}$ watt.

R6—100 Ω .

For Channel 4

R1*—6.8K Ω

R2*—4.7K Ω

tobacco tin of size: $4\frac{1}{2}$ in. by 3 in. by $\frac{3}{8}$ in. A very smart finish may be given to the tin by the application of a little "Acetone" this removes the paint and underneath will be found a silver plated finish. The two photographs illustrate clearly the general mode of construction and the layout of the coils, screens and smaller components. The tin is divided into three compartments by two screens. These may be formed from aluminium strip $13/16$ in. wide, and are drilled for rubber grommets to take the interconnecting leads, the B7G valveholder, and the two coils. The large section ((a) in circuit diagram) accommodates the power-pack components, and the glass bulb of valve V1. A number of small holes are neatly drilled around the side of this compartment in order to dissipate the heat developed by V1. The smaller section ((b) in circuit diagram), connecting with the B7G valveholder houses L1 and the smaller components in the amplifier circuit. The remaining section ((c) in the circuit diagram) takes the coil L2 and the isolating capacitor, C3, together with a three-way tag strip to anchor the length of coaxial cable. Two small holes are drilled in the side of the tin in line with the centre of the coils, and in each is fitted a small rubber grommet; enabling an insulated trimming tool to be inserted for core adjustment. Construction is eased if the screens are first positioned and marked for drilling, after which they are removed and assembled as a sub-chassis. The coils and valveholder may then be mounted and that section of the circuit wired as far as possible before refitting into the tin. As will be noted from the under chassis illustration one side of the coil base of L1 is cut off, this enables the coil to be mounted close to the side of the tin; making more room available around the B7G valveholder. For the same reason, the centre connecting lug on the Belling and Lee aerial socket is shortened. Small two- and three-way tag strips are used to anchor the coil connecting leads and the small components. The heater transformer and the smoothing capacitor C8/9 are mounted on the top of the tin adjacent to the 6H6 valve. To reduce the possibilities of instability a busbar of 18 S.W.G. should be employed for the H.T. negative end of the circuit and tied to the chassis via C5. Should the amplifier be powered by the receiver, the whole of the unit will be contained within the tin and more space, of course, will be available for the amplifier components. In which case a single screen dividing the tin into two compartments will be sufficient. The coils may be fitted one either side of the screen and the valve base in approximately the same position as with the self-powered unit. Most of the wiring may be

Most of the wiring may be

completed before fixing the screen within the tin and as before built as a sub-chassis. Owing to the small size of the unit, it was thought advisable not to include drilling dimensions, but the optimum position for the components may be readily evolved with the help of the accompanying illustrations and judicious component arranging. The lid of the tin forms the base of the pre-amplifier, which may be drilled and used to secure the unit to the receiver cabinet.

Operation

To facilitate simultaneous switching of the receiver and the pre-amplifier the mains input lead to the pre-amplifier should be connected to the receiver side of the on/off switch. The output from the pre-amplifier is terminated by a length of coaxial cable and should be connected to a plug suitable for the receiver it is to be used with.

Adjustment to the iron cores is extremely simple,

and does not usually require the assistance of a signal generator since the pass band is sufficiently wide to permit reception over the range of 41.5 Mc/s to 48 Mc/s for the reception of Alexandra Palace, 48 Mc/s to 52 Mc/s for the reception of Holme Moss, or 58 Mc/s to 62.5 Mc/s for the reception of Sutton Coldfield, provided that the two tuned circuits are slightly detuned.

Alignment is best performed with the help of test card "C," and is sufficient to adjust the aerial coil for maximum vision, after which the anode coil is adjusted for maximum vision. The core of the aerial coil is then screwed in about half a turn, while the core of the anode coil is unscrewed by about half a turn. This method will ensure the pre-amplifier is working at its maximum gain/bandwidth.

It is confidently expected that this simple pre-amplifier will considerably extend the range of any television receiver, and will give a new lease of life to a receiver which may have lost its sensitivity due to general ageing.

Replacement E.H.T. for V.C.R.97

A CHEAP REPAIR IDEA FOR RECEIVERS USING THE POPULAR SERVICE TUBE

By G3AC

HAVING some time ago suffered a burn-out on an E.H.T. transformer feeding the VCR97 tube in my home-constructed TV receiver, I unearthed a number of old but good and still efficient Ferranti inter-valve transformers, mostly of the split secondary push-pull output pattern, and with these I commenced the preliminary tests which consisted of applying mains voltage 210 A.C. to the primary sides of the transformers.

Measurements were then taken of the voltage at the secondary or output grid side of the transformers. These were found to vary with different transformers from 1,000 to 2,000 volts. Soak tests were then made and the transformers in every case withstood the test.

I installed one of these transformers in my TV power pack and then realised that I should not have any rectifier heater winding on this transformer.

Heater Windings Eliminated

I was able to dispense with the rectifier winding by obtaining two war surplus J.100 metal rectifiers rated at 1,700 volts 2 milliamps when two are "seriesed." These were then wired in series to give half-wave rectification (see Fig. 1).

The rectifiers were then installed with a transformer.

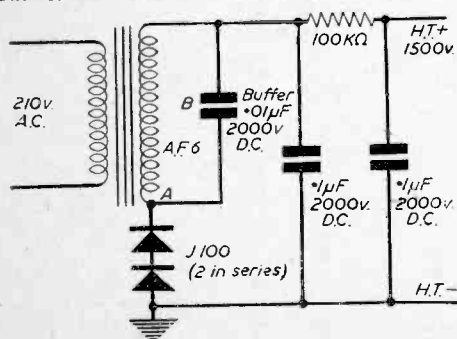

Fig. 1.—The original circuit.

I connected up to the mains, switched on, and took a D.C. voltage reading. I obtained 1,500 volts D.C. on the smoothed side of the filter after the tube and chain were supplied.

The produced raster, whilst lacking somewhat in intensity, was nevertheless a usable raster, but only for a few minutes, followed later by a complete short-circuit in the transformer.

This performance was repeated with another transformer which gave only 1,000 volts D.C. and with the same result.

Further tests were made and on touching point A with an insulated screwdriver (see Fig. 1) I was able, using another transformer, to draw a long spark which on measurement proved to be an A.C. voltage of 3,000 volts potential when the smoothed D.C. voltage was only of the order of 1,500 volts.

This was the cause of the breakdown. The unused half waves in the half-wave rectification circuit were being added to by the static charge in the smoothing condensers and doubling back, building up a high potential at point A.

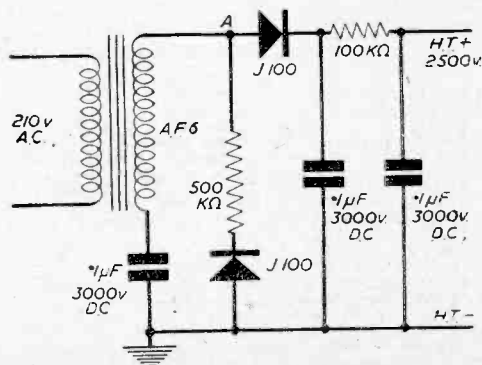

Fig. 2.—The improved circuit.

The next step was to stop this build-up which I did eventually by using the well-known technique used in vibrator supplies of adding a buffer condenser of .01 mfd. across the transformer's secondary terminals (see condenser B, Fig. 1).

Since this addition the transformer operated with a steady raster, which, however, was not of sufficient brilliance for my own personal needs.

A Rearrangement

Further experiments and a rearrangement of the components resulted in a voltage doubling circuit which now gives 2,500 volts smoothed D.C. and more than a sufficiently brilliant raster.

The rearrangement came about when the 3,000 volts A.C. on point A were being considered. Here were 3,000 volts A.C. needing rectification, so I broke up the series rectifiers, used one for the half-wave rectification to earth and the other one to rectify the 3,000 volts at point A (see Fig. 2).

Before switching on this new power pack I inserted an electrostatic voltmeter across the positive and negative to see how long the 850-volt metal rectifiers would stand up to this treatment, but after some weeks of this apparently heavy overload I am still obtaining the 2,500 volts D.C. and the rectifiers are working satisfactorily.

A Double-V Aerial

A READER'S EXPERIMENTAL ARRAY IN A REMOTE AREA

LIVING in the Southampton area the writer has tried various types of aerials. A standard H at $\frac{1}{4}$ -wave spacing, 31ft. high, was used for comparison. A multi-element array was made with .1 director and .15 reflector at the same height as H. A folded dipole was used to restore impedance with the unsplit portion a larger diameter. A triple folded dipole was also tested. This array was tried in two localities. In both cases the multi-element was not as good as the H. Another H was erected and gave identical results to the standard. Next a V aerial was tried with a V director; this was erected 3ft. lower than the standard H. The two lengths of coaxial were fed from each aerial to a home constructed TV receiver so they could be quickly changed. The double V gave a distinct improvement over the H. The sound was better, signal to noise ratio better, and at one period when there was no picture on H, one could be obtained on double V.

Construction

This aerial was easily constructed, using a 4-way electrical junction box. Aerial rods were made of $\frac{1}{2}$ in. steel tube. The lengths required for the Alexandra Palace transmission are: two 70in. (dipole) and two 64in. (director). The rods should be flattened one end, and drilled and tapped for a suitable screw; they should extend inside junction box $\frac{1}{2}$ in. Four pieces of $\frac{1}{2}$ in. conduit 4in. long, threaded $\frac{1}{2}$ in. to screw in junction box are also required. The rods are fixed in conduit and insulated by rubber hose $\frac{1}{2}$ in. outside diameter. Bostik "C" can be put around and in ends for additional weatherproofing.

The finished aerial is very light and is easy to erect to a good height.

The transformer being used at present is a type A.F.6 Ferranti with a step-up ratio of 1 to 7. The $\frac{1}{2}$ meg. resistor was inserted to prevent too heavy a passage of current to earth on conducting cycles.

The only difficulty experienced so far was when applying the new and increased E.H.T. to the tube, the raster assumed small proportions in the vertical and horizontal directions.

I was able to spread the horizontal deflection with the controls but had to rearrange the vertical amplifier circuit to accommodate the increased E.H.T.

For those who may be interested, the vertical sweep generator and amplifier was of a similar type to that used in "Inexpensive Television"—(second issue), using 300 volts on the plates of the amplifier, but I have since rearranged the amplifier to the type where the first triode section of the 6NS7 valve amplifies the sweep generator output after which a small part of the amplifier is fed out of phase from the anode to the grid of the second triode. This not only increased my raster size but also improved the linearity.

I now find that the buffer condenser is no longer required, the high voltage generated at point A is now consumed in doing a useful job of work but it must not be omitted where simple half-wave rectification is employed.

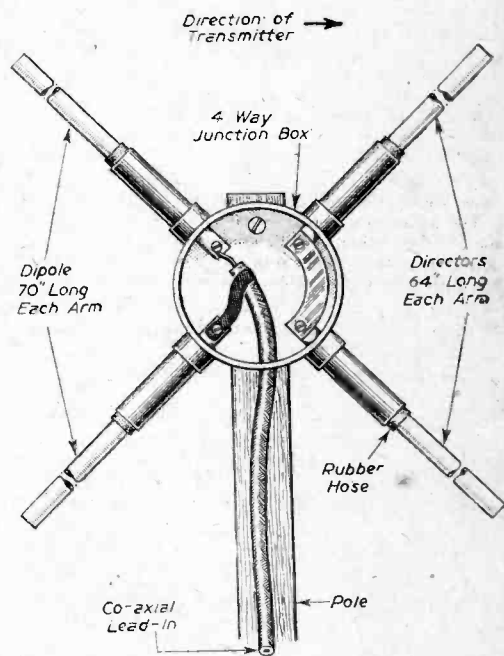

The aerial in detail.

Important

It is essential that the directors are linked together and pointed towards transmitter, with dipole farthest away from same.—D. PATER (Southampton).

INDEXES FOR VOL. 1 NOW READY
 || by post from George Newnes, Limited.,
 Southampton Street, Strand, W.C.2

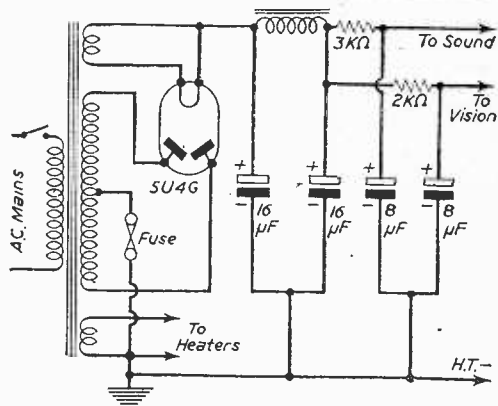

Fig. 7.—Suggested power-supply circuit.

transformer fulfilling these needs can be purchased readily.

A suggested circuit is given in Fig. 7. The components can be mounted on a simple chassis tucked away from the converted RDF unit; this means a great saving in weight so that the unit can be easily handled for adjustments and experiments.

Tube Circuit

Full details of the tube circuit have not been given, as there have been many suitable circuits using ex-Government tubes such as the VCR97, already published in PRACTICAL TELEVISION. The writer favours one in which the E.H.T. positive is earthed as it eases the strain on the E.H.T. transformer.

It can be constructed on an ex-Government chassis such as the 62 Indicator Unit, or can be mounted on a simple chassis built for the job. It is good practice to include the on-off switch with the brilliance control. One point to note is that if negative E.H.T. is earthed the coupling condensers C49, 53, 57, 61 (Fig. 6) should be 2.5 kV. working.

Alignment Procedure

It is best to get the time bases working satisfactorily before attempting alignment of the vision receiver. All controls should be set to their mid-way position (including C45) and the set switched on. The contrast control should be set at the minimum position and the aerial left disconnected. After switching on, the brilliance control should be set at a minimum for a short period, to allow the set to warm up. The brilliance should then be advanced until the raster appears and the latter should be focused until the lines are clear. The height can then be adjusted by means of the height control.

Alignment of the vision receiver is best done when Test Card C is being transmitted. Plug in the aerial, reduce the brilliance control until the raster just disappears, and then advance the contrast control until a pattern appears on the screen. The pattern can be resolved into the picture by adjusting the line hold control, and it should be locked in a vertical direction by the use of the frame hold control.

The tuning coils L2, 3, 7, 8 and 9 should then be adjusted so as to produce the best quality picture. It should be possible to resolve the 2.5 Mc/s lines by carefully trimming the tuning coils.

It will probably be found that the line and/or frame hold may be tripped by sound interference, or the picture may be marred by diagonal lines running across it. This can be eliminated by adjusting L5 and L6. To obtain

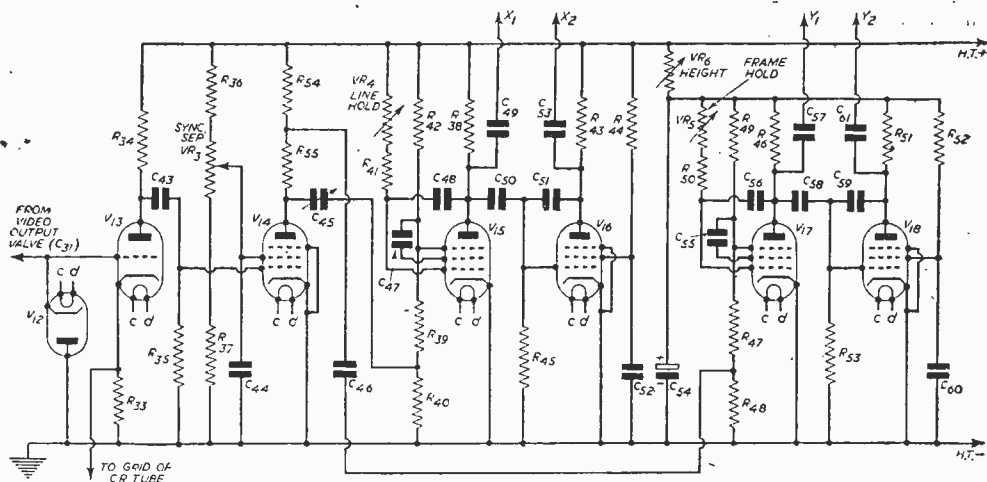

Fig. 6.—The time base.

TIME BASE COMPONENTS

C43, 44, 52, 60 = 0.1 μ F.
C45 = 0.30 pF.
C46, 49, 53, 55, 56, 57,
61 = 0.01 μ F.
C47, 48 = 100 pF.
C50, 51 = 50 pF.
C54 = 8 μ F.

C58, 59 = 0.001 μ F.
R33, 37, 48, 55 = 10 K Ω .
R40 = 4.71 K Ω .
R35 = 470 K Ω .
R54 = 50 K Ω .
R38, 43 = 120 K Ω .
R36, 39, 47 = 47 K Ω .

R41 = 1 M Ω .
R42, 44, 49, 52 = 56 K Ω .
R45 = 2 M Ω .
R51, 46 = 100 K Ω .
R50, 53 = 2.2 M Ω .
VR3 = 50 K Ω .
VR4 = 2 M Ω .

VR5 = 2 M Ω .
VR6 = 25 K Ω (wire
wound).
V12 = VR92.
V13 = VR137.
V15, 16, 17, 18 = VR65.

complete elimination of the sound it is a good idea to use the news bulletin period at the end of the day's transmission, when the video signal is not being radiated. A pair of earphones can be inserted in the output stage of the video valve, and the rejector coils adjusted until no sound signal is heard.

Should the picture be inclined to tear horizontally it is probably due to too large a sync pulse feeding the line oscillator: C45 should be adjusted for optimum results.

VR3 is used to obtain the best sync separation. If the line hold is inclined to vary with picture content it means that picture signal pulses are getting through to the line time base; this can be corrected by adjustment of VR3.

Should no picture be received the output from the

video receiver can be connected to the grid of the first A.F. valve; it should then be possible to hear the video signal when the volume control is turned up. When a strong signal is obtained by adjusting the tuning coils for maximum volume, the circuit can then be restored and the coils adjusted for quality of picture.

The numbers of turns given for the coils were obtained by experiment, and are the actual numbers used in the prototype; stray capacitances have a marked effect in this unit.

The alignment of the sound receiver is very simple, it only being necessary to screw the cores of the coils until they are flush with the tops of their formers, and then to adjust the trimmers T1, 2 and 3 until maximum volume is heard.

The Design of Video Frequency Output Stages—2

THE SECOND OF A SHORT SERIES EXPLAINING THE PRINCIPLES OF MODERN CIRCUITS

By K. D. J. Grosvenor

(Continued from page 215 October issue)

WHEN the basic circuit was considered it was found that in order to obtain a good high V.F. response a very low value of anode load had to be used; this resulted in the maximum possible voltage output being small. As a result it was decided that if the output was not sufficient a larger value of anode load would have to be used, and as a result a lower standard of performance at the high V.F. would have

The action of this small condenser is very simple to understand. At low and medium video frequencies the reactance of C_k is very high, and as a result an A.C. voltage corresponding to the signal will be developed across the bias resistor R_c at these frequencies; this will of course result in a relatively low gain due to negative feedback. At high V.F. the reactance of C_k becomes very small and consequently the feedback voltage must also become small, and as a result the gain rises; this rise in gain is made use of to compensate for the fall in output that would otherwise have occurred at these high frequencies due to the effect of C_s and the larger anode load.

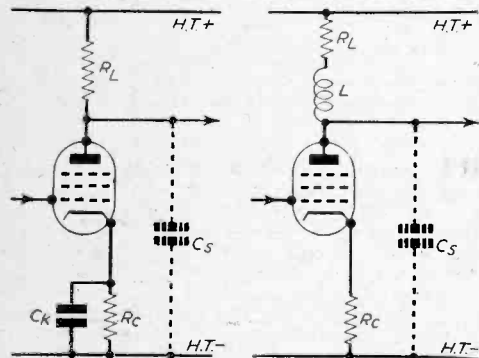

Fig. 6.—Cathode compensation circuit.

Fig. 7.—Peaking choke compensation circuit.

to be accepted unless a suitable compensating circuit was used to bring the performance back to a high standard again.

Cathode Compensation

This is the simplest of all compensating circuits (Fig. 6) and can be used when no cathode by-pass condenser is used. The circuit will be seen to be similar to the basic amplifier; the only real difference is that C_k is now a small-capacity, compensating condenser, and not a large cathode by-pass condenser.

This circuit has a number of advantages: it is simple and cheaper than the basic circuit, it has a perfect L.V.F. response and for a similar H.V.F. response is capable of giving twice the previous maximum output voltage. The only disadvantage is that the gain is only slightly increased and consequently a larger input signal is required to give the higher output. Incidentally, the circuit compensates for the otherwise poor time delay response as well as the amplitude response at the H.V.F.

For the benefit of those readers who wish to try designing their own circuit the following information is given:

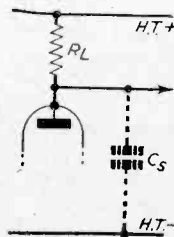

Fig. 8.—Fig. 7 without the peaking choke.

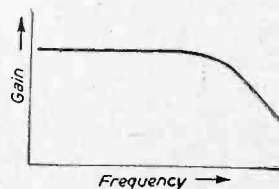

Fig. 9.—Response of circuit given in Fig. 8.

Let f = Highest V.F. of interest in Mc/s. (This will normally be 3 to 3.5 Mc/s.)

R_1 = Anode load in k-ohms.

R_c = Bias resistance in ohms.

C_k = Compensating condenser in pF.

C_s = Anode plus stray to earth capacity in pF.

G_m = Mutual conductance of the valve, at the already fixed value of bias and screen voltage.

$$\text{Make value of } R_1 = \frac{160}{f \times C_s} \text{ k-ohms}$$

$$\text{Make value of } C_s = \frac{160,000}{f \times R_c} \text{ pF}$$

The maximum peak to base output voltage will be for a positive going output about

$$\frac{4}{5} \times (I_{\text{mean}} \times R_1) \text{ volts (} I_{\text{mean}} \text{ being the no-signal anode current in mA.)}$$

When the video valve has a very high G_m such that $G_m \times R_c$ is greater than 500 the response will actually be better than the desired response. Thus, as always, a high- μ valve should be used.

Example.—(Assuming same values as in previous example.)

$$G_m = 8 \text{ mA/V. } R_c = 82\Omega. C_s = 20 \text{ pF. } f = 3 \text{ Mc/s.}$$

$$\text{Then } R_1 = \frac{160}{3 \times 20} = 2.7 \text{ K}\Omega. \text{ approx.}$$

$$C_k = \frac{160,000}{3 \times 82} = 650 \text{ pF.}$$

The maximum possible output voltage will be in this case seen to be twice that of the basic circuit for the same anode current since the value of R_1 is now twice the previous value. The response will be better than the desired response as $G_m \times R_c = 656$.

"Shunt Peaking" Compensation

This method is exceptionally good as not only does it give about twice the output voltage, it also gives about double the gain and consequently a larger input is not required. The time delay distortion is also kept very small. It is of course a little more complicated and difficult to design, but as it is so superior to other methods (apart from more complex circuits) it is the most widely used of all V.F. amplifier circuits.

To understand how it works it is easiest to consider it in a number of stages. The circuit is shown in Fig. 7.

(1) Assume that the peaking choke L is not present (Fig. 8), this is seen to be the same as the basic circuit and the response of this is known to fall off at high frequencies as shown in Fig. 9.

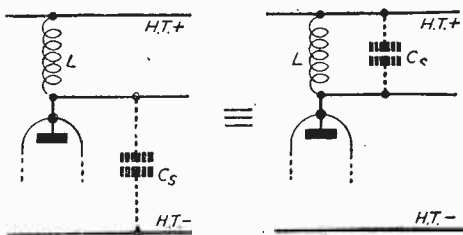

Figs. 10 and 11.—These two stages are actually identical so far as function is concerned.

(2) Assume that the anode load resistance R_1 is not present (Fig. 10). This circuit is identical to that of Fig. 11 as far as the response is concerned, and this latter circuit

will be recognised as an amplifier with a tuned anode load; such a circuit will of course give a very large output at the resonant frequency of the anode circuit. The response being similar to the solid curve in Fig. 12.

(3a) Now assume that a resistor is placed in series with the coil, this will make the Q of the tuned circuit low and as a result the response due to the coil and

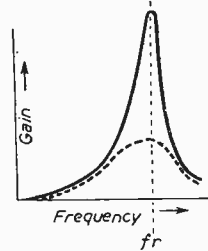

Fig. 12.—Response of circuit given in Figs. 10 and 11. (See text.)

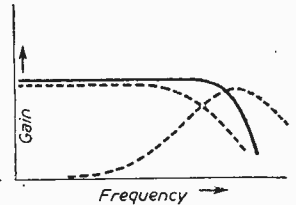

Fig. 13.—Graph showing overall response of shunt peaking circuit. (See text.)

capacity C_s will be flatter, as shown by the dotted curve in Fig. 12.

(3b) But by introducing the resistance in series with the peaking choke, one is, in fact, merely replacing the anode load R_1 and thus the actual response will be a combination of the response shown in Fig. 9 and the dotted curve of Fig. 12. The result of this combination is shown by the solid curve in Fig. 13.

It can be seen that this curve remains flat for a larger

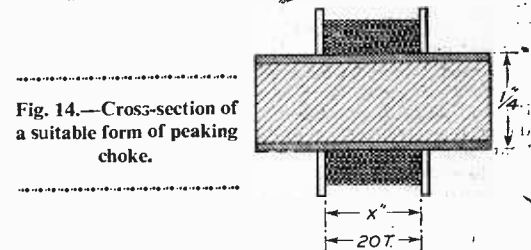

Fig. 14.—Cross-section of a suitable form of peaking choke.

frequency range than the curve for the resistive load alone, this being clearly due to the effect of the choke. The time delay distortion is reduced very considerably by this circuit (at the high video frequencies).

Obviously, one must use the correct values of anode load resistance and peaking choke inductance to get the desired results. It is, however, not too difficult to calculate suitable values, and for the benefit of interested readers the formulæ are given below.

$$\text{Make } R_1 = \frac{190}{f \times C_s} \text{ k-ohms.}$$

$$\text{Make } L = \frac{16,000}{f^2 \times C_s} \mu\text{H.}$$

Example: $f = 3 \text{ Mc/s. } C_s = 20 \text{ pF.}$

$$\text{then } R_1 = \frac{190}{3 \times 20} = 3.2 \text{ K}\Omega.$$

$$L = \frac{16,000}{3 \times 3 \times 20} = 89 \mu\text{H.}$$

Winding the Peaking Choke

Fig. 14 shows the dimensions of a suitable choke, the number of turns required can be obtained from the graph

(Fig. 15). The width of the coil should be just sufficient to get 20 turns per layer; thus if the wire used gives 80 turns per inch "x" will be $\frac{1}{4}$ in. The wire should be such as to give nearly 80 turns per inch (32, 34, 36 s.w.g.), as any very large variation from this figure will result in a coil of the wrong inductance.

Example.—From the previous calculation it was found that an inductance of 89 μ H was required. The graph gives the number of turns for the choke (when wound to drawing of Fig. 14) as 130 turns.

Alternatively, the number of turns can be calculated from the formula $T \approx 15\sqrt{L} - 0.13L$ (for values of L between 5 and 200 μ H).

$$\begin{aligned} T &= 15\sqrt{89} - 0.13 \times 89 \\ &= 15 \times 9.45 - 11.6 \\ &= 141.6 - 11.6 = 130 \text{ turns.} \end{aligned}$$

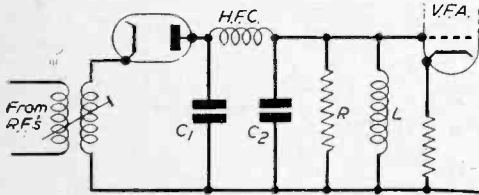

Fig. 15 (a).—Diode detector load circuit.

The Diode Load Circuit

So far it has been assumed that a good video signal arrives at the grid of the V.F. output valve; this, however, will only be the case if care is taken to avoid series loss and phase distortion in the diode detector load circuit at high video frequencies.

These losses, etc., are only at the H.V.F. and are due to the strays and capacitance of the R.F. filter circuit condensers C_1 and C_2 shunting the diode load resistor R (Fig. 15a). This is similar in many respects to that of the stray capacitance shunting of the V.F.A.'s anode load, and, as one may expect, similar methods can be used to minimise it.

First, the diode load is made small and the shunting capacitance kept to a practical minimum. Unfortunately, unless the diode load is made extremely small it is not often possible to get very good results, consequently some method of H.V.F. compensation is required.

One method which is, in theory, almost identical to that of the anode "shunt peaking" choke is the use of a peaking coil L as shown in Fig. 15a. However, there is another and very convenient method that can be used to compensate for the H.V.F. loss due to capacitive shunting of the diode load, providing the loss is not abnormal, and this is to align with the R.F. and/or I.F. circuits so as to accentuate the higher V.F. sidebands. As the majority of amateurs align "by the picture" this will be, in fact, automatically carried out.

This method, although quite satisfactory for correcting the phase shifts and losses occurring at the diode load (providing they are not excessive), is, unfortunately, not capable of compensating for the ill effects of the stray capacitance shunting the anode load of the V.F.A.

"Black after White"

This is a common effect of over-compensation; either due to unsuitable alignment of the R.F. and/or I.F. circuits or due to the anode load of the V.F.A. being too small in relation to the other components used in

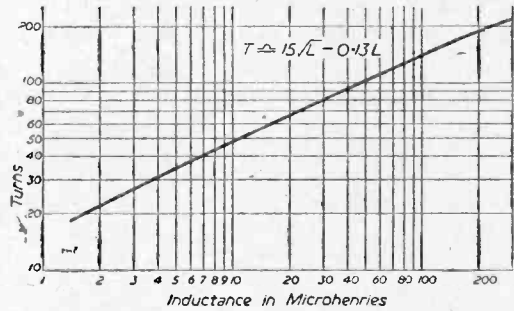

Fig. 15.—Graph showing relationship of peaking choke inductance and turns—for choke built on lines of Fig. 14 only.

the H.V.F. compensating circuit. It is the result of a peak in the response at the high V.F. end. A limited amount of "black after white" is sometimes desirable as it tends to make the picture appear sharper. However, the easiest method is to design for a flat response and introduce the "black after white" effect by suitable adjustment of the R.F./I.F. circuits if it is desired.

The D.C. Restorer

The action of the D.C. restorer is well known, namely that it maintains the "black level" constant by ensuring that the tips of the sync pulses are always at earth potential.

In addition to this well-known action, the restorer is also capable of reinserting the low video frequencies that are lost in the R.C. coupling. The action of the D.C. restorer will be to make all the tips of the sync pulses "sit" at earth potential which can be seen to give the original wave-form again.

Thus, when a D.C. restorer is used it is only necessary that there should be no appreciable distortion between sync pulses. It is probably due to this fact that some people make the mistake of assuming that (as the lowest component frequency in each line scan is 10,125 c/s) the normal value of coupling condenser and resistor is 1,000 times better than it need be.

(To be continued.)

SOLVE YOUR CHRISTMAS GIFT PROBLEMS THIS EASY AND EFFECTIVE WAY

The choice of Christmas Gifts for friends and relations is always a difficult business. Why not solve the problem this year in a novel, yet practical, way?

Look now at your Christmas list and you will see at once more than one relative or friend who would be delighted to receive PRACTICAL TELEVISION regularly. It is simple to arrange, for we can send subscription copies to any address, at home or abroad, at the annual rate of 13s. 6d. (Canada, 13s.).

AN ATTRACTIVE GREETINGS CARD WILL BE SENT IN YOUR NAME WITH THE FIRST GIFT COPY.

Just write to the Subscription Manager (Dept. G.1), PRACTICAL TELEVISION, Tower House, Southampton Street, Strand, London, W.C.2, enclosing the addresses of your friends, with remittance to cover, and we will do the rest. Remember, a Christmas Subscription for PRACTICAL TELEVISION is a Gift which will give pleasure and act as a reminder of your good wishes the whole year through.

SERVICING TELEVISION RECEIVERS—NEW SERIES

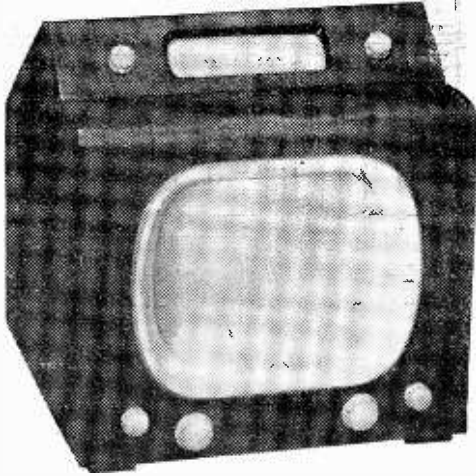

The Masteradio T851 television receiver.

WHILE ease of operation and stability of control settings are factors of importance to the television receiver owner, the ultimate result, which is the quality and definition of the picture, is very important. With the improvement in receiver design, enabling reception to be obtained from inferior aerial systems, the effect of such aerials is not always realised, and lack of picture definition is attributed to the receiver.

As the best of receivers can only be as good as the aerial with which it is being used, the discriminating viewer is well advised to satisfy himself in this respect. Quite often the results with an efficient aerial are offset by the coaxial cable which, although of the correct impedance for the type of aerial used, and suitable for the requirements of the receiver, which for Masteradio models should be 80 ohms, is adversely affected by the use of unsuitable plug and socket terminations.

It is often a practice to tap the main lead from the aerial in order to run leads to various rooms, so that the receiver can be used where required. This is quite in order, providing suitable junction boxes have been used and that the impedance of the coaxial aerial lead has not been affected. Suitable junction boxes are available from manufacturers who specialise in this type of equipment.

The effect of a mismatched coaxial cable junction will not only cause signal losses, but usually reduces picture definition by a considerable amount. In most homes the receiver has an almost permanent position and only occasionally is moved to another room. Where this is the case, the lead from the aerial should be direct and without joins to the semi-permanent position, and a further lead (which is disconnected when not in use) should be installed from this point to the alternative operating position.

Presuming that the aerial system is satisfactory, it is quite possible that lack of definition is due to the control adjustment of the receiver. It may be that the brilliance and picture definition has deteriorated since the receiver was originally installed. This has probably been a very gradual change which the viewer has not noticed at the time.

When the receiver has been in use for several years,

2.—Masteradio

MODELS T851, T852, T412 and T409

this loss of definition and brilliance may be due to the formation of a dust film on the screen of the cathode-ray tube and the inside surface of the glass panel which protects the C.R. tube. Due to the heat from the valves, air is constantly circulating through the receiver and dust is drawn into the cabinet. It is also possible that the Focus control has to be turned fully to the left or right when in the best working position, so that without a reserve of movement on either side of the optimum setting it is not possible to obtain maximum definition and focus. Such a condition can be corrected as explained later.

The settings of the various pre-set controls all contribute to the final result, the method of adjustment varying for different types of receivers.

Models T851 and T852

Both of these models incorporate superhet circuits for vision and sound reception and the setting of the pre-set controls differs from the usual procedure.

Before removing the back of the receiver it should be realised that the chassis is "live" to one side of the supply mains, so that before any adjustments are carried out a safety check should be made to ascertain whether the chassis is at "live" or earth potential.

Reference to Fig. 1 will show the positions of the pre-set controls, the focus on some models being effected by rotating the knob, and on others by movement of the focus lever, which is not shown.

At this stage, check that the voltage setting is correct for the supply mains, as this is an important point which is so often overlooked. With the receiver in operation, and with a picture "locked," turn the Sensitivity control (at rear) with a screwdriver to the minimum position (fully anti-clockwise). Then turn the Contrast control (at front) fully clockwise.

Gradually increase the Sensitivity pre-set control until the picture reappears and continue until the picture is slightly over-contrasted (i.e. a "hard" picture which tends to lack graduation between greys and blacks). While these adjustments are being carried out it will be necessary constantly to readjust the Brilliance control for the best setting. The Spotter control (at rear) should also be in the "off" position (fully clockwise).

Now turn the Contrast control back until, in conjunction with the Brilliance control, a "smooth" picture is obtained. This is best done when either the BBC's test card "C" or the tuning clock is being transmitted. Both of these have sections of white, light grey, dark grey and black and should be clearly seen.

The Focus knob or lever should be adjusted while observing the screen for the setting which gives best focus over the whole picture.

Height and Width

Should the picture be smaller than the viewing aperture, adjust either the Height or Width controls as required, and in the event of the picture being to one side, or not central in the viewing aperture, the three nuts round the base of the C.R. tube mounting can be individually adjusted as required for correction.

Any sloping of the picture can be rectified by slight rotary movement of the scanning coil assembly on the neck of the C.R. tube. Care must be taken to avoid touching the anode cap of the C.R. tube and live connecting tags on the scanning coil unit.

The Line Linearity control expands the centre of the picture sideways, which is different from many receivers, where this control affects the left-hand edge of the screen only.

If the centre circle of the test card is not round, it can be corrected by adjusting either the Vertical Linearity control on the top surface of the chassis or the line linearity knob, depending on the requirements of the picture.

Sensitivity

As already explained, the Sensitivity control setting should be kept as low as possible with the normal operating position of the Contrast control almost at maximum (clockwise). Under these conditions the level of the sound should be ample for normal room requirements with the volume control turned almost to maximum. As the Sensitivity control affects both sound and vision circuits, it may be necessary in areas where the signal level of sound and vision is unbalanced to increase slightly the sound level for normal requirements.

Should this be necessary, check first that the aerial, R.F. and oscillator coil cores (back of chassis) are correctly adjusted for optimum reception.

Trimmers

Using an insulated screwdriver-ended trimmer tool, adjust the oscillator coil core (see Fig. 1) for maximum sound reception, then observe the screen and adjust the aerial and R.F. cores for maximum picture signal, reducing the Contrast control if necessary. It is essential that the oscillator core is adjusted for best sound results before the aerial and R.F. cores are set for maximum picture signal.

As the iron dust cores are easily damaged, avoid using a metal-tipped trimming tool. A bone or plastic knitting needle, filed to a screwdriver end, makes an ideal trimming tool. Do not exert pressure on the dust cores, as this is not necessary and may break the coil former fixings as well as the dust core itself. The other tuning cores on the top surface of the chassis should be left untouched, as adjustment of these requires a signal generator and other test gear, together with the manufacturer's data.

Focus Control

The Focus control knob or lever should have a reserve of movement on either side of the optimum setting, indicating that the best focus position has been achieved.

Should this not be the case, the three nuts round the base of the C.R. tube rear mounting should be adjusted in step, while rocking the Focus control and observing the screen, until the control can be moved on either side of the setting for best focus.

Adjustment of the three nuts will probably cause the picture to shift, but individual adjustment of the nuts will enable this to be corrected, after the correct focusing conditions have been attained.

Spotter and Interference Limiter

If the site is one where there is constant interference on the picture due to passing cars, then the Spotter control will be an advantage. It should be turned very slowly, starting from the full clockwise position until the bright

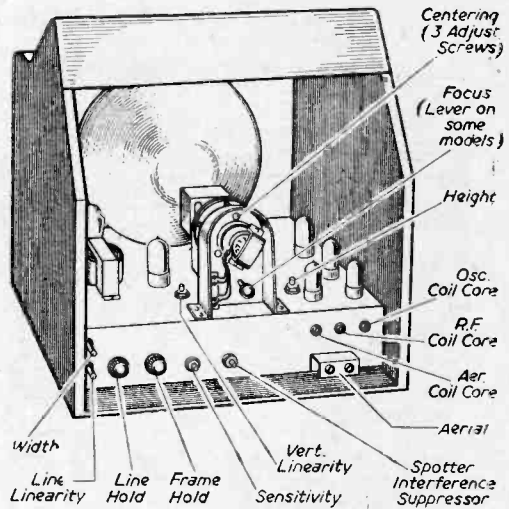

Fig. 1.—Location of Masteradio pre-set controls.

interference spots are reduced and the quality of the picture not unduly affected.

Unless picture interference is constant and excessive, then the Spotter control should not be used but kept in the full clockwise position, as its use will affect definition.

Tuning to a Different BBC Transmitter

Models T851 and T852 can be adjusted to operate from any present or future BBC television station. This will enable viewers who are now receiving programmes from the Midland transmitter at Sutton Coldfield to change to the new Holme Moss station if their location is nearer to the new transmitter.

The adjustment procedure does not involve the use of any test equipment and is carried out in a similar manner to that already described for checking the settings of the three dust core trimmers on the rear edge of the chassis.

First the oscillator coil should be adjusted which, when tuning from Sutton Coldfield to Holme Moss, will mean that it should be screwed slowly in (clockwise) until the sound from the station required is obtained.

The core should be set to the position which gives the maximum result, and if the signal is strong, there may be distortion, in which case reduce the Sensitivity control. The remaining R.F. and aerial coil cores should now be adjusted clockwise in step, until the picture is received, adjusting the Brilliance control as required, and left at the settings which give maximum picture results. As already explained, the Sensitivity pre-set control affects both sound and vision.

Finally, check the setting of the Sensitivity control in the manner described earlier.

Model T851 Radio Unit

Incorporated in Model T851 is a radio chassis for ordinary sound reception on medium- and long-wave bands.

Attached to the chassis is a frame aerial which, under normal conditions, enables satisfactory reception to be obtained. In some areas, and where conditions are not suitable for frame aerial reception, a single open-ended loop of insulated wire can be fixed against the

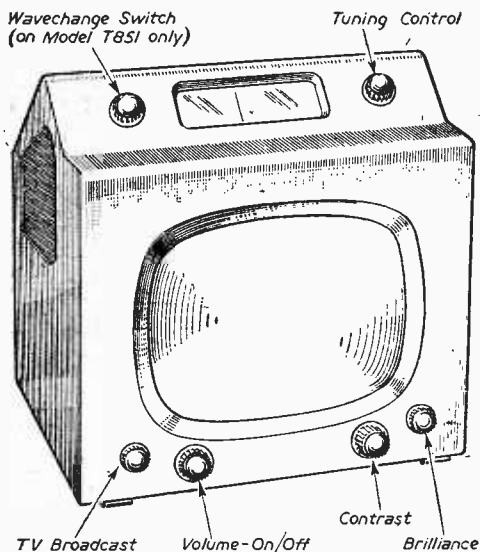

Fig. 2.—The controls of Masteradio T851.

frame aerial and connected to TV aerial terminal "E" (see back of receiver).

Some radio chassis will have a plastic-covered lead already attached to the frame aerial for this purpose.

To prevent the possibility of electrical failure, always turn the volume on/off control to the "off" position while switching over to radio or television.

Models T412 and T409 T.R.F. Receivers

There are many Masteradio Model T412 receivers which have now been in use for several years and which would have the original picture brightness restored, if the C.R. tube screen is cleaned.

This necessitates the removal of the main chassis from the cabinet, which is held by four bolts under the shelf above the power unit.

The three control knobs are easily removed, but the spring-loaded webbing harness which holds the 12in. C.R. tube to the front of the cabinet may appear difficult to remove. The two loading springs are hooked into eyelets and a pair of long pointed-nosed pliers will enable the front end of the springs to be gripped and unhooked.

Before the chassis can be removed, it will be necessary to remove the plug from the power unit, and to disconnect the heavy rubber-covered E.H.T. lead which connects to the anode cap of the C.R. tube.

Care should be taken, as this lead is attached to the anode cap by a clip which, if not removed for a year or so, may be difficult to dislodge and any effort to pull or twist may cause the C.R. tube anode cap to break off. To prevent this possibility, the flat end of a pencil or similar object should be pressed against the top of the anode cap while the clip is removed (see Fig. 3).

When the chassis is out of the cabinet, the C.R. tube screen can be cleaned with a damp cloth which has been lightly smeared with soap. This treatment can also be given to the inside surface of the glass protecting panel of the cabinet. Any marks on the rubber mask can usually be removed with soap, although once the surface has been discoloured it will not be possible to clean.

In such cases, a mask can be made to look new again by applying white ceiling distemper.

As the C.R. tube is a delicate and costly article, the method of mounting must not stress the tube in any way. When cleaning the tube face, notice whether the tube is pressed backwards, as displacement from the original position will affect the setting of the focus coil.

When the chassis has been refitted into the cabinet, switch on, and while observing the picture, adjust the Focus control for best setting. At this point there should be a reserve of movement of the control on either side. Should this not be the case, or good focus cannot be obtained, then it would indicate that either the focus coil requires adjusting by the three nuts around the C.R. tube rear mounting, or if focus is impossible, then in all probability the C.R. tube has been displaced from its original position and has been pressed backwards during the cleaning process.

Adjustment of the picture for width and height and the correction of picture slope are effected in the manner described for models T851 and T852. This also applies to the three nuts round the base of the C.R. tube. The other adjustments do not apply to this model.

The Contrast pre-set control should be set to give the brightest picture without loss of shade graduation, and white, light grey, dark grey and black on the test cards should be quite distinct. As the Contrast control also affects sound reception, the setting which gives best picture results should also be suitable for the sound requirements.

Should there be insufficient volume, the iron dust cores of the two sound coils can be adjusted with an insulated trimmer tool of the type already described for maximum sound results.

Care must be taken to see that the dust core is not screwed out of the coil former, otherwise replacement will necessitate removal of the coil can. The picture must be carefully watched for sound or vision effects which will occur if the aerial coil is tuned too near to the sound channel frequency. No other core adjustments are recommended without the manufacturer's data and the necessary V.H.F. signal generator.

SPECIFICATION OF THE MASTERADIO RECEIVERS, T852, T851

The T852 is a 12in. table model television with tinted screen—adjustable for reception from all BBC television transmitters, with superhet receiver for sound and vision.

The T851 specification is the same as that for the T852, with the addition of a built-in radio receiver for M.W. and L.W.

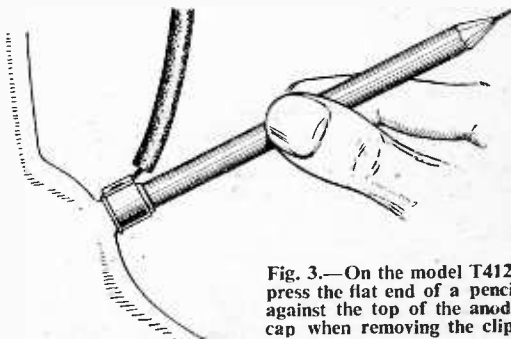

Fig. 3.—On the model T412, press the flat end of a pencil against the top of the anode cap when removing the clip.

Specially useful for Television Work . . .

The WIDE-RANGE SIGNAL GENERATOR

A Signal Generator of wide range and accuracy of performance, designed to cope with modern radio and television work. Turret coil switching provides six frequency ranges covering 50 Kc/s—80 Mc/s.

50 Kc/s—150 Kc/s	1.5 Mc/s—5.5 Mc/s
150 Kc/s—500 Kc/s	5.5 Mc/s—20 Mc/s
500 Kc/s—1.5 Mc/s	20 Mc/s—80 Mc/s

Stray field less than $1\mu\text{V}$ per metre at a distance of 1 metre from instrument. General level of R.F. harmonic content of order of 1%.

Direct calibration upon fundamental frequencies throughout range, accuracy being better than 1% of scale reading. 4.5 inches of directly calibrated frequency scales with unique illuminated band selection, giving particularly good discrimination when tuning television "staggered" circuits.

Of pleasing external appearance with robust internal mechanical construction

using cast aluminium screening, careful attention having been devoted to layout of components with subsidiary screening to reduce the minimum signal to negligible level even at 80 Mc/s.

Four continuously attenuated ranges using well-designed double attenuator system.

Force output 0.5 volts.

Internal modulation at 400 c/s, modulation depth 30%, with variable L.F. signal available for external use.

Mains input, 100-130 V. and 200-260 V. 50-60 c/s. A.C.



MAINS MODEL, as specified, or BATTERY MODEL, covering 50 Kc/s to 70 Mc/s, powered by easily obtainable batteries. . . . **£30**

Fully descriptive Pamphlet available on application to the Sole Proprietors and Manufacturers:

The AUTOMATIC COIL WINDER & ELECTRICAL EQUIPMENT CO. LTD.

WINDER HOUSE · DOUGLAS STREET · LONDON · S.W.1 Telephone: VICTORIA 340419

S.G.1

BUILD YOUR OWN MODERN RECEIVER for HALF the normal cost

You're SURE to get it at
STERN'S
ESTABLISHED 25 YEARS

SOME POPULAR CIRCUITS for the HOME CONSTRUCTOR

- ★ **A MIDGET 4 STATION "PRE-SET" SUPERHET. RECEIVER** for A.C. mains. Designed to receive any three stations on Medium Waveband and one on Long Wave by the turn of a Rotary Switch, no Tuning being necessary. The set can be supplied either as a Complete Kit of Parts, or by purchase of the Components separately. The Complete Assembly Instructions, showing the Wiring Diagram and Component Layout and Point to Point connections, together with a Component Price List, available for 19.
- ★ **A 4-VALVE T.R.F. BATTERY PORTABLE "PERSONAL" SET**, available as a Complete Kit of Parts or by purchase of the Components separately. The complete price details, including an individual Component Price List are included in our set of Assembly Instructions, which is obtainable for 9d. In addition, these detailed Assembly Instructions also show the complete circuit, with a Practical Component Layout, which in themselves make the assembly of the set quite simple.
- ★ **A MIDGET 4-VALVE SUPERHET. PERSONAL SET**, covering Long and Medium Wavebands and designed for Mains or Battery operation. This receiver is designed to operate on A.C. mains or by an "All-dry" Battery; either method is selected by means of a Rotary Switch. It is so designed that the Mains Section is supplied as a separate section which may be incorporated at any time. The set, therefore, can be made either as an "All-dry" Battery Personal set or as a Midget Receiver for Combined Mains/Battery operation. The set can be supplied either as a Complete Kit of Parts or by purchase of the Components separately. The Assembly Instructions, which include Wiring Diagram and Practical Component Layouts, are available for 19. This also includes a separate Components Price List.

- ★ **THE MIDGET A.C. MAINS 3-VALVE RECEIVER**, as designed and published by "Wireless World," covering Long and Medium Wavebands. Cost of all Components to build this set is £4 17/9. A reprint of the complete Assembly Instructions, including Practical Layouts, is available for 9d.
- ★ **THE "WIRELESS WORLD" MIDGET A.C. MAINS 2-VALVE RECEIVER**. We can supply all the components including Valves and M/Coil Speaker, to build this set for £3 10/0. Reprint of the original Assembly Instructions and Circuit may be obtained for 9d.
- ★ **THE "SUMMER ALLDRY" BATTERY PORTABLE**, as published in the June issue of "Practical Wireless." We can supply from stock all the Components to build this Midget 3-valve Receiver. A reprint of the complete article and circuits, including Practical Layout and Component Price List is available for 14.
- ★ **A COMPLETE KIT OF PARTS TO BUILD A MIDGET "All-dry" BATTERY ELIMINATOR**, giving approx. 60 volts and 1.4 volts. This eliminator is suitable for use with 4-valve Superhet. Personal Sets. It is easily and quickly assembled and is housed in a case size 4 1/2 in. x 1 1/2 in. Price of Complete Kit, 42/6. In addition we can offer a similar complete kit to provide approx. 90 volts and 1.4 volts. Size of assembled unit 7 in. x 2 1/2 in. x 1 1/2 in. Price 47/6.
- ★ For £6/5/0. A Complete Kit of Parts, including Drilled Chassis and Valves, to build a 6 to 8 watt **PUSH-PULL AMPLIFIER** for operation on A.C. Mains. Incorporates Tone Control and is suitable for use with any type of pick-up. The complete set of Assembly Circuits, including Practical Layouts, is available for 9d.

★ Send 9d. P.O. for our NEW STOCK LIST, showing many KITS OF PARTS for Sets and Battery Chargers and "hundreds" of Wireless Components. When ordering please cover cost of postage and packing.

STERN RADIO LTD., 109 & 115, FLEET STREET, E.C.4.

Telephone: CENTRAL 5814 & 2280

T/V TECHNOLOGY



Home Study will give you a fuller understanding of Television problems

To the enthusiast for whom television is an absorbing interest and who wishes to understand more about it, or to those who are constructing their own sets, and want complete knowledge of the theory underlying the constructional details, ICS offer a sound, practical and comprehensive course of instruction. It has given a high level of efficiency to many, who studied in their own time. What about you?

FOR THE ENTHUSIAST OR INTENDING T/V ENGINEER

Course 'A' provides a sound introduction to radio and television principles, deals with the principles of reception and transmission, and includes the preliminary study of Mathematics, Electrotechnics and Radio and Television.

Course 'B' offers a more comprehensive treatment of receiving equipment, deals in detail with modern principles of transmission and reception, and contains the necessary introductory instruction in mathematics, electrotechnology and radio.

The ICS also offer the following Courses in Radio :

- Complete Radio Engineering
- Radio Service Engineers
- Radio Service and Sales
- Advanced Short-Wave Radio
- Elementary Electronics, Radar and Radio

And the following Radio Examinations :

- British Institution of Radio Engineers
- P.M.G. Certificates for Wireless Operators
- City and Guilds Telecommunications
- Wireless Operators and Wireless Mechanics, R.A.F.

For FREE BOOKLET and full details of these highly successful courses, fill in and post the coupon below.

Generous Discount granted to Members of H.M. Forces.

CUT HERE

**INTERNATIONAL
CORRESPONDENCE SCHOOLS LTD.**
(Dept. P.T.15)

International Buildings Kingsway, London, W.C.2.

Please send booklet on subject.....

Name..... Age.....
(BLOCK LETTERS, PLEASE)

Address.....

"YOU CAN RELY ON US" FOR CLEAN COMPONENTS AT COMPETITIVE PRICES

VALVE DATA MANUALS

MULLARD, 5/- MARCONI OSRAM, 5/- BRIMAR, 5/-

VALVES

C1C	10/-	U79	10/-	6K6	8/8
CV1141	5/-	VU120A	4/8	6K7 metal	8/-
DH63	12/-	W61	7/8	6K7G	8/-
EA50	3/6	104	8/6	6L7 metal	8/6
EB333 Gov.	8/6	105	8/6	6SA7gt	8/-
EB41	8/6	154	10/6	6SK7 metal	8/-
EB31	8/6	174	9/6	6SH7 metal	7/6
EF39	10/6	334	8/6	6ZY5	6/2
EF39 Gov.	7/6	304	7/6	12SF7	7/6
EF50	7/6	3Q5gt	8/-	12A6	7/-
EF54	7/6	354	10/6	12SC7	7/-
EF55	8/6	5Z3	8/-	12SK7	8/-
EF91	10/6	5Z4 metal	9/-	12SK7	8/-
EF92	12/6	6AG5	9/6	12SR7	6/6
EL32	8/-	6AK6	8/6	76	6/-
EL33	10/6	6B8m	8/-	77	7/6
EL35	8/6	6C4	7/8	80	10/-
EL42	8/6	6C5m	7/8	954	5/-
KTW61	8/6	6C5gt	7/-	955	5/-
KT33C	16/-	6D6	8/-	9003	5/-
MS/Pen	6/6	6H6m	4/6	VU111	7/6
N37	10/6	6J5gt	6/6	35Z5	12/6
Pen46	8/-	6J7 metal	8/-	35Z4gt	12/6
PT25H	5/-	6J7G	8/-	25Z5	12/6

Postage 6d. any quantity.

Thousands of valves in stock including many BVA types at List Price. Let us know your requirements and we will quote the price.

SWITCHES—Rotary : 1 pole. 18 way. 2/6. 4 pole. 3 way. 4/- 3 pole. 4 way. 4/- 2 pole. 6 way. 4/- 6 pole. 3 way. 4/6.
SELENIUM RECTIFIERS—2v. 11a. 7/6. 250v. max. 75ma. 7/6.
 Type 14D38, 12/6. Type 14A88, 13/6. Type 36EH100, 26/8. WX3, 3/5.
 WX6, 3/5. Meter rectifiers, midget, 5 m.a., 1/-.
EASYBUILT CHASSIS—Two chassis for the Easybuilt Television, heavy gauge tinplate soldered four sides, 8/6 each. EF53 3in. x 3in. screens, 6d. Ask for complete list of parts.
SPEAKERS—2in. WB, 17/3. 6in. R.A., 12/6. 6in. Truvox with Trans., 16/-. 8in. Plessey Lightweight, 16/-.
HAYNES COMPONENTS—Scanning Coil Units. Type S914, S914H, S112, each 42/-. Transformer Type TUY586, 22/-. TQ115, 11/-. Choke Type LUS9F, 22/-. LUS6L, 16/6. Focus Units PM15A Tetrode. PM20A Triode, each 30/6.
TELEVISION TRANSFORMERS—RS, 6G, 200-250v. tapped 350-0-350v. 250 m.a., 6.3v. 8 a., 6.3v. and 2v. at 1a., 5v. at 2.5a., 6/6.
FILAMENT TRANSFORMERS—Midget dimensions, finished in green crackle. Primary 210-240v. to 6.3v. 1.5a., 3/6; to 6.3v. 3a., 12/6; to 4v. 3a., 12/6. Multi purpose type for instruments, models, etc., Tappings 3v. to 30v. at 2 amp., 21/-.
SPEAKER TRANSFORMERS—Super Midget for personals, DL92, 3S4, 1S4, 5/- Standard Pentode, 4/6; 60 and 30 : 1, 4/6; 30 : 1, 4/- Mains Pentode Midget, 4/-.
COILS—Wearite "D" Coils, 3/- Wearite Viewmaster coils, per set. London, 20/-; Midland, 25/- Holme Moss, 30/- MW/LW TRF Matched pair with circuit, 7/6 Weymouth C37W3, 9/6 pair. CS2W2, 11/6 pair. K.O. Coils, 4/9. "H" Coils, 3/3.
I.F. TRANSFORMERS—RS 6G Semi-Midget 465 kc/s, 12/6 pair. Wearite M400B, M 401, 21/- pair. Weymouth F4, 15/- pair.
FORMERS—Aladdin with cores, 1in. 7d., 1in. 10d., 1in. 9d. Cores 1in. 3d., 1in. 4d.
BOOKS—Viewmaster Book and Circuits, 5/- London or Midland, Easybuilt Television, 2/6; Portable Television, 3/-; Personal Portables, 2/6.
MISCELLANEOUS—Bulgin Octal plug 2/- Belling-Lee Co-axial plug 1/6, Socket 1/3, Connector 1/6, Bulgin rotary DP Switch 4/3, Bulgin feeder plug 1/3, Socket 1/3.
ELECTROLYTICS—2 mfd. 350v. 1/3. 4 mfd. 350v. 1/6. 4 mfd. 500v. 2/- 8 mfd. 350v. 2/6 8 mfd. 500v. 3/6. 16 mfd. 450v. 4/6. 16 mfd. 350v. 3/- 32 mfd. 450v. 4/9. 60-100 mfd. 350v. 9/- 8 mfd.-18 mfd. 450 v. 5/6. Offer 30-30 mfd. 350v. 6/-.
CHOKES—First quality Audio Chokes, high impedance, 10/6. 40 m.a. Midget 5/-, 60 m.a. 6/6, 150 m.a. 14/6, 250 m.a. 21/- shrouded. Smoothing chokes.
ICC PIPPACKS; ETC—Pipocaps 2/6. Metalmins 1/8, .001 mfd. 6 kv. 4/6. .001 mfd. 12 kv. 7/6. Hunts W89 .001 mfd. 1/3.

We regret unavoidable price increases on most surplus valves and a few standard components, but our aim is still, Quality First.

Our No. 10 Catalogue, price 6d., Post Free.
 Postage : Over £2 free, below 10/- 6d., 11/9d., £2 1/-.

RADIO SERVICING CO.

444, WANDSWORTH ROAD, CLAPHAM, LONDON, S.W.8.

Telephone MACaulay 4155.
 77, 77A, 168, 169 Bus. S.R. Station, Wandsworth Road.
 Open till 6.30 p.m. 1 o'clock Wednesday.

THE FINISHING TOUCHES

COMMON FAULTS IN HOME-CONSTRUCTED APPARATUS EXPLAINED

By Bernard Barnard

MANY readers appear to experience similar faults in their home-constructed apparatus, and the following notes deal with some of these and endeavour to explain both the cause and the cure. In the main, they concern receivers which are "home-designed," as well as home-constructed, and it is thought unlikely that any of the following notes will apply to first-class published designs or commercial receivers.

By far the commonest fault that readers complain of is poor definition. That is to say, the picture holds perfectly on line and frame and is of good contrast and gradation, but is lacking in detail, particularly on long shots.

Bandwidth

The first—and too often, the only—function of the receiver to come under suspicion in such a case is bandwidth. It is, of course, perfectly true that a narrow bandwidth will cause poor definition, but it usually causes several other troubles at the same time, so that it can be recognised by a quite casual glance at the screen. "Snow" (amplifier noise) particularly at the corners of the picture and the tearing out of the picture detail are two of these other faults which are directly due to narrow bandwidth and consequent "peaky" tuned circuits.

However, we have to deal with the possibility of too narrow bandwidth, especially with superhets, and very often this has to be done without the assistance of a signal generator.

It is quite possible to get a good idea of the bandwidth of an I.F. amplifier on vision by slowly rotating the oscillator tuning condenser whilst a steady picture—preferably Test Card C—is being received. It should be possible to rotate the condenser over quite a large arc between the positions at which the picture appears and disappears without the brilliance of the picture changing appreciably. If, as is sometimes the case, the picture appears at two distinct positions of the oscillator with a black space in between, then obviously the I.F. tuned circuits are "double-humped" and careful retuning is indicated.

It is not possible, of course, to give more than a vague indication as to how large this tuning arc should be, since it must vary considerably with different designs and oscillator component values. But quite a good idea can be obtained by first noticing how much spread is obtained on the sound channel—which will not be more than equivalent of 100 kc/s—and then allowing somewhere about thirty times this for the vision channel. In practice the sound channel tuning is usually very critical and it is difficult to gauge the tuning arc, but it is often well worth the trouble of rigging up a rough, long pointer from the oscillator variable condenser so that the sound goes in and out over as much as $\frac{1}{2}$ in. of pointer travel. It is then easy to check that the vision channel extends over the required arc.

So much for I.F. amplifier bandwidth. Where else can we lose the fine picture detail? The answer is, of course, almost anywhere between the aerial and the C.R. tube; indeed, the aerial itself can cause the trouble

if it is badly designed and its elements are constructed from too thin or poor quality material.

Attention should next be directed towards the vision detector and video amplifier. For it is here that much good signal energy in the 2-3 Mc/s region can be lost or, more commonly, under-amplified in comparison with the amplification given to other picture frequencies. There have been several excellent articles in PRACTICAL TELEVISION on the video stage, in recent months, and it is not intended to repeat what has been said on the subject. But there are several simple tests that will give a good idea as to whether the demodulator and vision amplifier are doing their respective jobs properly.

First, it is desirable to "explode" a widely held misconception. If you have a signal generator and inject a modulated signal into the I.F. or R.F. amplifier and swing the generator frequency from, say, 10 to 13 Mc/s and get a nice steady pattern on the tube, this does *not*

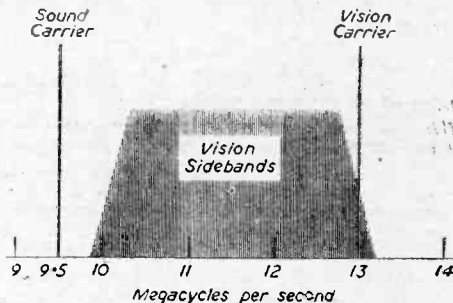

Fig. 1.—Response curve for a single sideband receiver.

test the detector or video amplifier for response. The only frequency dealt with by these stages in this test will be the modulating frequency of the generator, usually 500 or 1,000 cycles.

As regards the vision detector it must be remembered that this valve has to handle the wide band of vision frequencies and the usual values associated with broadcast apparatus just will not do. Check first the values of load resistor and condenser—3.3 k Ω and 20 pF are typical values—and check the wiring to these components to make sure that it does not run in such a manner as to add materially to the very modest 20 pF. Compensating or correcting chokes should be watched for the same reason: their self-capacity will be taken into account in their design, but their capacity to earth or chassis may add a considerable load to the circuit.

In the video amplifier, of course, stray capacities are the great bugbear and generally the best and, in the end, the quickest way of checking the performance of the amplifier is progressively to reduce the value of the anode load resistor from, say, 7,000 ohms to about 2,500 in 1,000-ohm steps, and to note carefully the effect on picture quality. The gain will, of course, go down; but if the quality and detail improve then it is certain that there are excessive stray capacities in the circuit and a new wiring layout should be tried. Using valves like

SP61s, it should be quite possible to arrange the wiring so that a load resistor of 6.7 K Ω can be used without loss of picture detail.

Tuning

On this question of picture definition, the last point concerns the actual tuning of the receiver for single sideband working. Fig. 1 illustrates how this should be done, and it is not a very easy thing to explain. The main point to understand is that, unlike tuning for ordinary twin sideband reception, the tuning is "offset" so that the carrier is received at considerably less strength than the sidebands. Referring this to a superhet receiver (for simplicity, since it has only one tuning control) it means that the oscillator control must be so adjusted that the vision carrier is received at about half strength and at that end of the vision channel remote from the sound carrier. An easy way of understanding this point is to cut out two pieces of card of the same size and shape as the shaded area in Fig. 1. If you let one of these represent the band of frequencies sent out by the transmitter, and the other the acceptance band of your receiver, then you can slide the "receiver" over the "transmitter"; clearly, there is only one position in which all the transmitted energy is accepted by the receiver—that is, when the two cards coincide exactly—from which it is a straightforward deduction that there is only one position of the oscillator tuning condenser which will allow all the picture elements to reach the vision detector.

Heating of Components

The next most common fault that readers report is that which develops after the receiver has been running for half an hour or so. Amongst these are loss of sync, deterioration of picture quality and hum.

It is a fairly safe guess that these faults are caused by components—mainly resistors—getting over-hot and changing their rated values for this reason. If the fault develops suddenly then a definitely faulty component can be looked for, but if, as is more often the case, the change in reception comes on gradually then the cause is probably more obscure. Loss of sync and change of picture quality generally means oscillator frequency drift in superhets. The cure usually calls for a change in component layout. The oscillator components must be kept away from anything that gets hot—such as valves, load resistors and so on. And the oscillator valve itself must be run at the lowest possible anode voltage so that it does not itself generate appreciable heat. Heating of the valve will, of course, cause frequency drift due to the resulting change in its inter-electrode capacities as well as that due to rise in temperature of its associated components.

Mains hum has been mentioned because several readers have complained of this developing when the receiver is thoroughly warmed up. It is difficult to find a fault to fit this complaint but it is most likely due to a falling off of signal strength and consequent decrease in signal/hum ratio at the tube grid. When E.H.T. is obtained by means of the mains transformer and rectifier combination, there is nearly always some residual hum to be seen on the screen in the form of a single dark bar. This hum voltage, of course, remains at constant strength irrespective of signal strength or amplifier gain. With a normal vision signal the signal/hum ratio may be as high as 40 : 1 and the hum is not noticeable. But if the picture strength falls considerably, the hum voltage becomes commensurate with signal volts and the dark bar will be obvious. An extreme illustration of this case

is offered whenever a programme is faded out to a blank screen. How many receivers using half-wave mains rectifier E.H.T. supplies can show an evenly illuminated screen?

The fall in signal strength mentioned above may be due to a normal picture fade in the fringe areas, in which case there is not much that can be done about it. But it is equally possible that frequency drift is responsible in which case all three faults that we started with may be due to the one cause.

Faulty Components

Faulty resistors and condensers are difficult to locate and home constructors who have not had much experience of service work are inclined to take them for granted: in actual fact one finds a fair proportion of "duds" amongst them. In general, they tend to go "high"—that is to say, they change in value to a resistance which is considerably higher than their rated value—and there they stay. But occasionally you will find the odd one that remains at normal value until it gets warm; it will then either go suddenly open circuit or to a very much higher value than normal. It is usually a very tedious business finding such a faulty component, and, unless you have unlimited time and patience, it is probably best to replace all resistances in the suspected area.

Interference Patterns

Another common fault which seriously spoils an otherwise good picture is the "herring-bone" interference pattern which dances about the screen. A good deal of careful note-taking and analysis is desirable before tackling this fault because there are several possible sources of the trouble and it is only by this means that we can eliminate those sources which are *not* the cause of the trouble.

In this case we have to draw a distinct line between the straight set and the superhet—to the advantage of the straight which is much less liable to this kind of fault.

If you are using a straight-type of receiver and suffer from this sort of interference, then it is almost certain that outside interference is responsible. You will note that it does not occur at all times and in doing so, may be lucky enough to get a strong clue as to the source of the interference. In this case it may be possible to construct a wave-trap that will remove it completely.

In considering this interference, much of its mystery is removed if it is remembered that it is exactly the same as the heterodyne whistles that are heard on any type of radio receiver.

In a superheterodyne receiver, there are several other ways in which the interference can be generated inside the set so that the matter is complicated to that extent. The outside interference bugbear applies, of course, to this type of set as to the straight receiver.

The sources of the trouble are, then, the same as those which cause heterodyne whistles in a superhet radio receiver and we can list them as follows:

- (a) A transmitting station, or its harmonic, interfering at radio frequency.
- (b) A transmitting station, or its harmonic, interfering at intermediate frequency.
- (c) As in (b), but second channel.
- (d) Various unwanted frequencies produced by the action of the vision detector getting to the C.R. tube either direct or via undesirable couplings.

If asked to put these in order of common occurrence, I would put (b) first, followed by (d); (c) is very unlikely

unless the receiver happens to be in a locality where there is a very strong interfering transmitter on the second channel.

The answer to (b) is, of course, very thorough screening particularly in the region of the first I.F. grid circuit. If you want to test this, try connecting an inch or two of wire to the grid pin of the first I.F. valve and notice the "hash" that is immediately apparent on the screen. The other point to be watched, of course, is that the I.F. chosen is on a quiet part of the frequency band and it is often the case that a shift of I.F. frequency of 1 Mc/s will be sufficient to cure a really bad case of "herringbone" interference.

(d) is taken care of in all good designs by incorporating a suitable filter system in the vision detector circuit. If you are using a receiver of your own design, possibly incorporating an ex-Government I.F. strip, make sure that there is such a filter system in the detector circuit. If you have any doubt about it, it is advisable to copy the filter used in a good published design but make sure that the I.F. is the same in both cases.

The last crop of faults which have come to my notice are those which indicate trouble in the C.R. tube itself. Tubes, of course, lose their emission and fluorescence

but it is sometimes forgotten that they can develop other and more obscure faults. This applies to electrostatic and magnetic types equally, but the former have been discussed at some length from time to time in the correspondence columns of this journal so I will content myself with a short list of faults that I have found in magnetic tubes in recent months. The symptoms, as described, are exact but the causes are a matter for conjecture as I did not, of course, have the opportunity to break down the tubes to examine them. They were, in every case, however, replaced by the manufacturers under guarantee.

1. Brilliance very low until running for about 20 minutes. It then rose suddenly to normal. Suggests faulty grid or cathode weld.

2. Blocks of lines—about 40 at a time—pulling out about $\frac{1}{2}$ in. to the right of the raster: picture at times completely blurred. Suggests intermittent contact at cathode weld.

3. Impossible to focus (magnetic). Soft, or may be due to gun displacement.

4. Impossible to centre picture without large black shadow at side or top (according to orientation of tube). Gun displaced.

COLOUR IN U.S.A.

TELEVISION broadcasters, distributors and dealers from many parts of America had an opportunity to view the R.C.A. compatible, all-electronic colour television system during a new series of field tests scheduled by the Radio Corporation of America and the National Broadcasting Co., which began in New York on September 10.

Soon after completion of this series, it was announced the general public will be invited to witness further testing of R.C.A.'s improved techniques and apparatus, including experimental colour television receivers equipped with the R.C.A. tri-colour picture tube.

Arrangements for viewing have been set up in the Center Theatre and the R.C.A. Exhibition Hall in Radio City, where the colour transmissions will be received in both colour and black-and-white.

Because of the compatibility of the R.C.A. colour system with present black-and-white standards, all television-set owners in the metropolitan area can view the tests in black-and-white on Channel Four. As in the July tests, R.C.A. intends to invite all viewers to assist in the forthcoming tests by reporting how the transmissions compare with the regular black-and-white reception.

New Colour Tube

An improved tube that receives television programmes in both black-and-white and colour without the need of any colour wheel converter, and which can be mass-produced at a cost only slightly above that of present black-and-white receivers, was demonstrated recently. The private showing was held for electronic engineers and physicists at the offices of the Paramount Pictures Corporation.

The tube, which promises to bring colour television to the home much sooner than expected, was developed by Prof. Ernest O. Lawrence of the University of California, winner of the Nobel Prize in physics for his invention of the cyclotron, and one of the world's outstanding atomic scientists.

Dr. Lawrence said he developed it in his spare time in his hobby shop near Berkeley, California, in response to questionings by his children. He said it was in no way connected with his work as director of the University of California Radiation Laboratory.

It requires only a few relatively simple and inexpensive additions to the present-day conventional black-and-white television tubes to produce his tube for receiving television in colour.

The tube consists of the conventional metal envelope and single electron gun. Inside it, within half an inch of the curved viewing screen, is a colour viewing glass plate, lined alternately with many phosphor lines in blue, green and red. Connected to this plate is a wire grid consisting of multiple electronic lenses. This grid is electronically registered with the phosphor colour strips.

The wire grid is a simple electronic lens that serves to deflect electrons to the right colour strips on the glass colour viewing plate, at a rate equal to the colour switching rate of transmission. It can be adapted to any system of colour transmission, being able to follow any colour system or black-and-white system.

The electronic lens swings the electron beam alternately on the different colour strips on the glass viewing screen by shifting the polarity of the wires in step with the colour switching frequency.

Instead of being accelerated to 12,000 volts on coming out of the electron gun at the base of the tube, the electrons in the Lawrence colour tube come out with an initial voltage of only 4,000. When they reach the wire grid they get an additional 8,000 volts, bringing the voltage up to the normal 12,000. A variation of a few hundred volts plus or minus acts to swing the electron beam alternately on the different colour strips.

REFRESHER COURSE IN MATHEMATICS
8/6, by post 9/-
by F. J. CAMM
GEORGE NEWNES, LTD.
Tower House, Southampton Street, London, W.C.2

A PART from "jamming" by unwanted transmissions or "atmospherics," interference with broadcast reception was at first rare, though some trouble was experienced from ordinary receivers used in a radiating condition either unwittingly or in an effort to obtain the maximum amplification. Such misuse was, in fact, an infringement of the conditions of the licence and, when complaint was made, the Post Office had to investigate and educate and/or admonish offenders. This type of interference later became less frequent with the introduction of sets of improved performance. Up to this time, the work devolving on the Post Office in keeping interference under control was negligible and field investigations were carried out in the evening, after normal hours of duty.

Then came the great growth in popularity of broadcast entertainment and the general expansion of electricity supplies. Mains-operated radio sets rapidly came to the fore, as well as the multitude of electrically-operated industrial, commercial and domestic appliances and machinery, which help to speed up production in industry, reduce drudgery in the home and add generally to the amenities of modern life. Nearly all this apparatus is a potential source of interference if used in the vicinity of a broadcast set. The complaints reaching the Post Office increased steadily and the work of investigating interference complaints could no longer be properly and economically carried out by telephone and telegraph staff in their "spare time."

The Organisation Takes Shape

Gradually staff became employed for an appreciable part of their normal hours of duty on radio-interference work. Many weary miles were covered, on foot and by public transport, by men loaded down with a portable receiver in one hand and a bag of tools in the other. In 1932, it was decided that the work should be done by full-time radio-interference investi-

The Radio Inter

FULL DETAILS OF THE G.P.O. SERVICE FOR TRA

By G. A. C.

gation officers (I.O.s) in the field, who should have the rank of Skilled Workmen, Class I. The first major steps towards efficient organisation were taken in 1933-1935, when the Engineer-in-Chief arranged the provision of special motor-vehicles, apparatus and training courses. The vehicles, which had non-metallic bodies

to permit the use of aerials contained within the vans, carried not only the portable receivers used for tracing interference to its source, but also an extensive range of standard suppressors, which were used primarily for demonstrating but upon request

This article is reproduced of the Post Office "Tele" kind permission of His M

were also sold to owners of apparatus causing interference. All staff employed regularly on the work were required to obtain special qualification by means of courses in R.I. run by the Training School and Radio Branch in collaboration. For many years the Radio Branch decided the syllabus and provided the lecturer for R.I. courses, as well as much of the equipment, the School providing basic instruction, facilities and accommodation. The I.O.s had assistants where warranted and were attached to the Sectional Engineer, usually under the supervision of an Inspector on a maintenance or power duty. It was recognised that the latter could not be expected to be a radio expert, and technical supervision was vested in the Superintending Engineer, whose office, in most cases, had one or more Inspectors who were R.I. specialists, and who made frequent



Fig. 1.—Ignition interference on a television screen.

ference Service

WORKING DOWN INTERFERENCE AND SUPPRESSING IT

Britton, A.M.I.E.E.

visits to sections to co-operate with the local field staff.

In addition, a "Broadcast Interference Group" was established within the Radio Branch of the Engineer-in-Chief's Office. Its main responsibilities were training, provision of apparatus and transport, dealing with radio exhibitions, technical advice to district staff, and frequent visits to them. In fact, at one time the endeavour was made to visit each I.O. once a year.

ed from the August issue
communications" Journal by
jesty's Postmaster-General.

The Coming of Television

An experimental low-definition television service opened in 1929. Pictures were crude and small, transmission times very limited and programmes unambitious, so it is not surprising that they had little public appeal. The real public service at high definition began in November, 1936. Right up to the war, receivers were not exceptionally sensitive and they were used only at short distances from the transmitter. Few complaints of interference (T.V.I.) were received. Over 40,000 complaints of R.I. and over 100 of T.V.I. were received per annum in the years just before the war. During the war, the R.I. service was kept going in skeleton form. Bad R.I. cases were dealt with, the aim being to enable listeners to receive the BBC "Home" programme reasonably satisfactorily, and much work was done for the Services and Government Departments, whose many radio and radar installations in this country were, on occasions, subject to interference.

The Post-war Years

As the country readjusted itself to conditions of peace, broadcast reception of sound resumed its normal position in daily life, and the television service restarted.

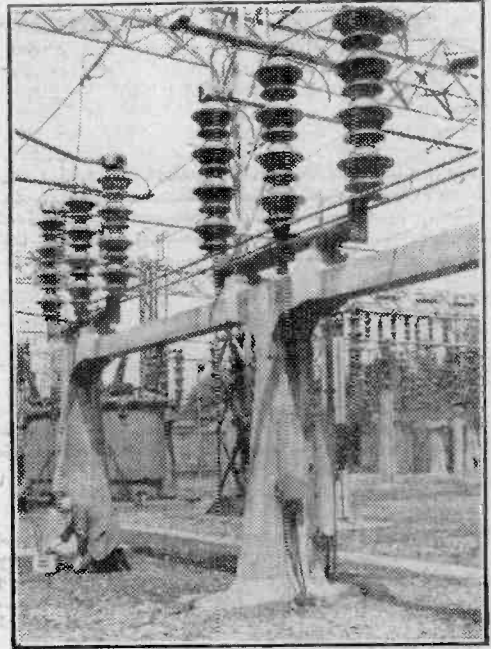

Fig. 2.—Seeking the source of interference in an E.H.T. sub-station.

The latter at once made rapid progress, and it has made even more rapid progress since. With the opening of the Sutton Coldfield station, the BBC began the extension of service to the provinces. We now have to deal with 77,000 sound and 28,000 television interference complaints a year. The possibility of eliminating unnecessary complaints, which are an appreciable proportion of the total, and of increasing the efficiency of the service is being investigated very carefully.

The original single training course given to I.O.s

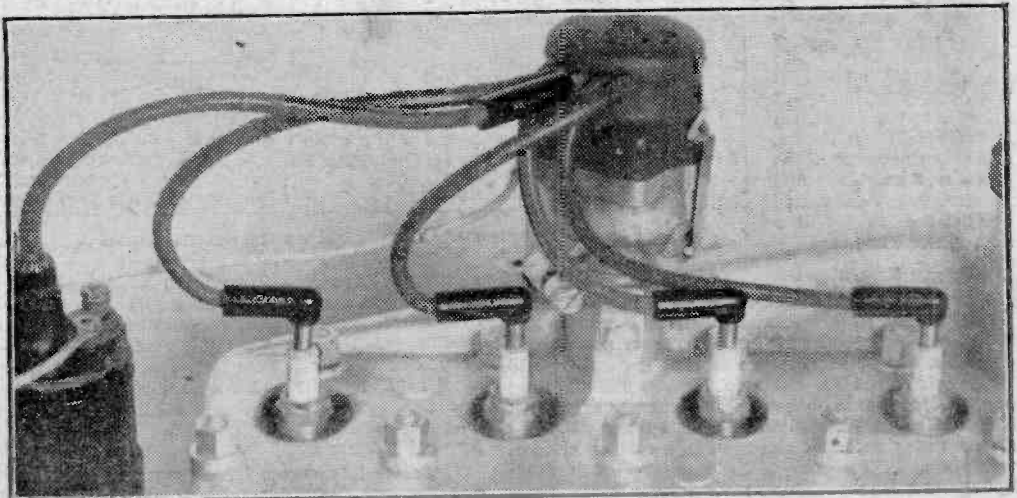

Fig. 3.—Car engine with suppressors fitted.

has now been replaced by separate courses in basic radio theory, radio (i.e., sound broadcasting) interference and television interference. All are now run wholly by the Training Branch at the Central Engineering Training School at Stone. Under full regionalisation, the visits from the Engineering Department to Technical Officers have been discontinued, though the Engineering Department continues to collaborate with them in the more difficult field investigations. Regular conferences between the Engineering Department and radio staff at Regional Headquarters are now held. The introduction of standard suppressors for television began several years ago and the whole range is now available to the I.O.

The vast majority of owners of interfering apparatus has always co-operated willingly with the Post Office and had suppressors fitted at its own expense. There has, however, always been the un-co-operative minority, and to deal with such people the Wireless Telegraphy Act, 1949, now gives the Postmaster-General power to make and enforce regulations which prescribe what have been regarded by an impartial committee as reasonable arrangements for countering interference.

Some Data and Technicalities

For several years, detailed records of the types of apparatus causing interference have been kept by Telephone Managers and summarised by the Engineering Department. The present period is one of change and development, which is reflected in the annual analyses of returns. The principal causes of complaint in the 12 months ended December 31st, 1950, are given in the Table. The most striking feature in each case is the large number of fruitless complaints, i.e., those in which the interference is intermittent and never occurs during the I.O.'s visits; or it is of such short duration as to defeat all efforts to track it to its source. In some of these cases, the interference is undoubtedly due to impending breakdown of an electrical appliance or machine; no doubt the actual breakdown occurs, skilled maintenance is given, and both fault and interference are eliminated before the Post Office investigator comes near.

Interference Suppressors

Except in a few special cases, practically all interference results from sudden changes or discontinuities in electrical circuits, such as may be caused by the operation of commutator-type motors, the making and breaking of contacts, and the discontinuities inherent in operating gaseous discharge devices such as fluorescent lamps. The circuit-changes impress on the electricity supply mains sudden changes of potential or current, which contain components at even very high radio frequencies; in addition, radio-frequency energy is radiated into space. These components are known as

"radio noise" voltages, currents and fields. Practically all electrical apparatus contains the elements essential to generating interference. In fact, the most severe and widespread interference is caused by the noise voltages and currents fed back into the electricity mains by low-power apparatus. The problem of suppression, once the source has been located, is therefore generally one of attenuating the noise voltages and currents and restricting the circulation of the latter to the immediate vicinity of their source. This can be done by inserting in series, between the apparatus and the mains, impedances (or suppressors) which are negligible in their effect on the power-current driving the apparatus, but have a value as high as possible at the radio-frequencies concerned; also by shunting between the mains and the framework of the apparatus, impedances as low as possible at the radio-frequencies but extremely high at the frequency of the power-current (in the United Kingdom, usually 50 c/s).

Fig. 4 shows suppressors being connected to a domestic vacuum cleaner. In this particular instance, it has been necessary to use one unit to be effectual at the low frequencies used for sound broadcasting and another for the higher television frequencies.

The electrical ignition system of a motor car has the characteristic of producing interference which is negligible at low frequencies and does not become severe until the television frequency band is reached (Fig. 1). The interference is produced solely by radiation, there being no electric mains to convey the interference energy

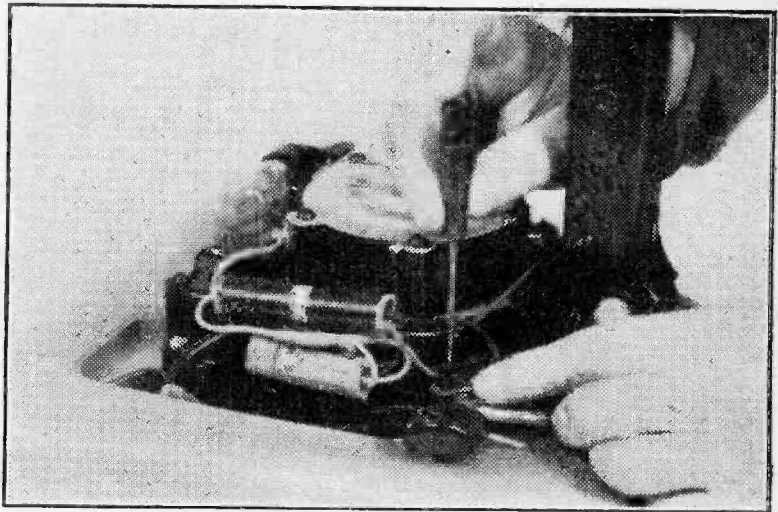

Fig. 4.—Suppressors being fitted to a vacuum cleaner.

away from its source. Suppression is obtained, without adverse effect on the performance of the car engine, by connecting one or more resistors in the high-voltage ignition leads, to "damp out" oscillation. In many cases, one resistor is adequate, though some vehicles require more. Five are shown fitted to the engine in Fig. 3.

Personal Matters

The radio interference I.O. is something of a "lone wolf" among the staff, practically all of his work being carried out away from Post Office premises, in the open

THE MOST FREQUENT SOURCES OF INTERFERENCE WITH RECEPTION OF SOUND BROADCASTING, EXPRESSED AS A PERCENTAGE OF CASES CLOSED.

	SOUND		TELEVISION	
	* complaints	%	* complaints	%
Unknown ; interference not observed by P.O. staff ...	(18,018)	23.8	(7,068)	29.2
Inefficient aerial/earth systems ...	15,246	20.1	947	3.9
Faulty receivers ...	9,507	12.5	1,972	8.2
Faulty wiring of buildings ...	5,029	6.6	234	0.9
Refrigerators ...	2,255	3.0	331	1.4
Fluorescent tubes ...	1,787	2.4	—	—
Radiation from T.V. receiver time base ccts. ...	1,725	2.3	—	—
Radio transmitters ...	1,469	2.0	1,007	4.2
Bedwarmers ...	1,423	1.9	—	—
Motors, misc. ...	1,334	1.8	315	1.3
Sewing machines ...	1,162	1.5	2,374	9.8
Overhead power lines ...	900	1.2	632	2.6
Drills ...	791	1.0	221	0.8
Radiation from I.F. oscillators of radio receivers ...	622	0.8	156	0.6
Misoperation of receivers ...	539	0.7	204	0.8
Thermostats, misc. ...	539	0.7	184	0.7
Smoothing irons ...	528	0.7	—	—
Vacuum cleaners ...	527	0.7	257	0.9
Neon sign tubes ...	503	0.7	192	0.8
Underground mains ...	492	0.6	—	—
External cross modulation ...	414	0.5	—	—
Fans ...	391	0.5	521	2.1
Calculating machines ...	353	0.5	150	0.6
Hairdryers ...	292	0.4	697	2.9
Motor car ignition ...	—	—	1,096	4.5
Medical apparatus (valve-operated) ...	—	—	306	1.2
Filament-type lamps ...	—	—	305	1.2

* The figures in the first and third columns do not necessarily represent the number of complaints received. For example, the fourth item from the end means that of the complainants whose sound-reception problems were solved, 0.4% had been collectively troubled by interference from 292 hairdryers.

air and in premises of complainants and owners of "suspected" apparatus. Technically also, the I.O. is comparatively isolated; he may be the only Post Office man in his headquarters town to be employed on radio duties. His work brings him into intimate daily contact with the public and he has to be at one and the same time a technician, sleuth and diplomat. The qualities required of a good I.O. are therefore somewhat different from those required of the majority of engineering staff. The main requirements are that the I.O. should be self-reliant and able to "get on well" with complainants and plant-owners, and that he should have an adequate technical knowledge and "flair" for locating sources of interference.

Interference of considerable duration, which is sufficiently obliging to be present during the I.O.'s visit, is not particularly difficult to localise and suppression is usually straightforward. Interference of intermittent occurrence and short duration is another matter entirely, and it is here that the "natural" investigator, whose instinct and past experience are used to reinforce the process of observation and deduction, has a chance to excel: does the interference occur only after dark?—on early-closing days?—when the weather is wet—or dry—or hot—or cold?—when there is a strong wind? All such factors not only can and do come into play, but to the knowledgeable I.O. they may give a valuable clue to the probable nature of the source of the interference, and hence to the type of premises on which it is most likely to be found. Not all intermittent interference is accompanied by such pointers, however;

imagine, for example, the feeling of hopelessness which must pervade the I.O. shown in Fig. 2, who is seeking, among a large collection of high voltage electrical plant, for one loose connection or corroded joint which he believes to be the cause of widespread interference with television reception. The work undoubtedly has its attractions though, and few members of the radio interference staff would willingly change to other duties. The extreme variety of work encountered is alone a constant source of interest; the man who is dealing one day with interference at a power station may encounter, in consecutive jobs, interference from a small electric shaver in a home, the lift in a block of flats, the neon signs outside the local cinema, and so on.

Nor are paths and humour entirely absent. Dealing with the lighter side, the listener who thinks the soil in the flower-pot indoors to be a satisfactory earth for the radio set exists not merely in the imagination of a music-hall artist: he is encountered in real life from time to time.

Perhaps the most curious incident the writer has heard of recently is the "barking-dog" case, for details of which he is indebted to the Coventry radio staff.

As the story runs, several residents in a village near Coventry were troubled by dog-barks, which were heard via the loud-speakers of their radio sets, and one of the affected residents registered a complaint with the G.P.O. The experiences of the local radio staff were decidedly out of the ordinary. One listener visited asserted that she heard the dog-barks on her radio set. No set was

(concluded on page 284.)

Underwater Television

THE "AFFRAY" FOUND BY TELEVISION—ANOTHER USE FOR MODERN EQUIPMENT

THE Admiralty recently made public the news that they had used television equipment in the discovery of the sunken submarine *Affray*. This was the first official indication that any service uses were being made of standard television equipment, and subsequently it was stated that the Marconi Company had co-operated in the design and manufacture of this apparatus. A standard television camera was used, and was enclosed in a special waterproof housing. This camera was of a type not requiring the very high power lighting which is normally expected in a television setting, and it was able to produce a reasonable picture at the great depths in which the *Affray* was found. Several wrecks, discovered on the Asdic apparatus, were pinpointed, and later a specially equipped salvage ship travelled from one to the other with the television equipment. When finally located the nameplate was seen by the observers above and an illustration of the picture on the television receiver screen is given below.

company's 32-core type extensively used for BBC broadcasts, but it was provided with an additional special protective sheathing making it suitable for use many fathoms under the sea. It was possible, therefore, to link the camera (258ft. under the sea) with the control

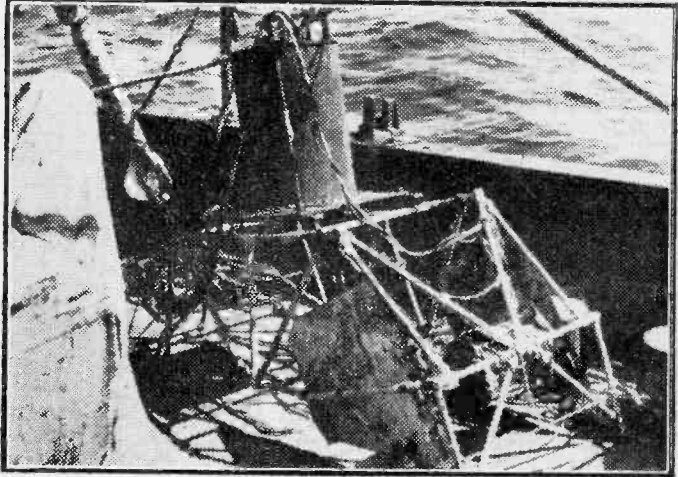

The camera container and lights in their frame on board H.M.S. "Reclaim."

Special Cable

In connection with the development of this unique apparatus—the further use of which has infinite possibilities—British Insulated Callender's Cables, Ltd., received a request from the Admiralty to solve the urgent problem of producing a television camera cable to meet the particularly arduous conditions.

The required cable was produced and supplied within a matter of a few days. Its design is very similar to the

equipment aboard the salvage vessel by a single cable capable of dealing with video signals, scan currents, power supply and, in fact, all the necessary circuits.

The camera is self-propelled and once it has been lowered the cameraman on the ship above can drive it ahead or astern, and train the lens in any desired direction.

The chief problem is in lighting objects at great depths, and we understand that the Canadian Navy are experimenting in this connection with similar equipment.

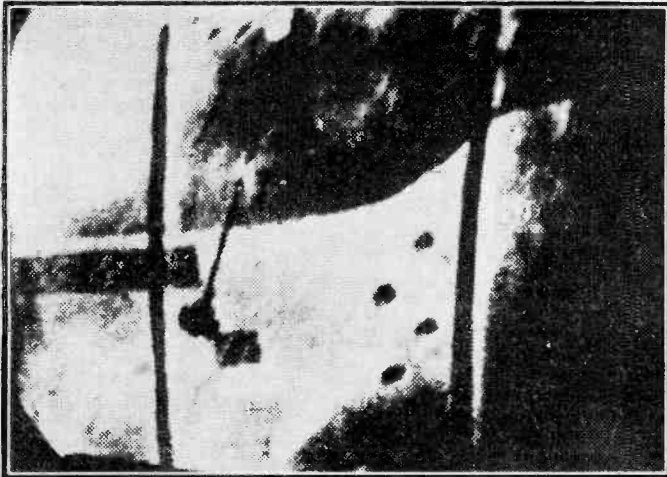

On the left may be seen part of the nameplate of the "Affray." This is an unretouched picture of the receiver tube.

"VIEWMASTER" PARTS Ample and Continuing Supplies Available

We are asked to correct a misleading statement which appeared in an advertisement in our October issue, in which it was stated that the manufacture of "Viewmaster" parts had ceased.

This is completely incorrect, as the manufacture of these parts is in fact being intensified by all the manufacturers concerned as is obvious by the publication of Envelope C announced elsewhere in this issue.

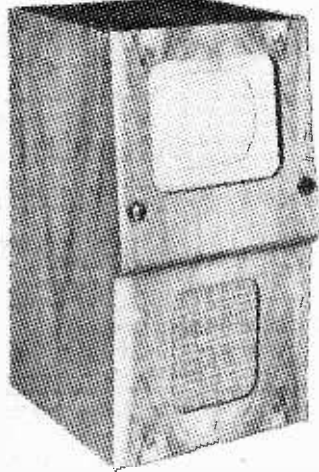

LASKY'S RADIO

DE LUXE TELEVISION CABINETS

For 9, 10 or 12in. cathode ray tubes. Beautiful figured medium walnut finish, with high polish. Fitted with shelf for receiver, glass, speaker grille and fret, and castors for easy movement.

Engrilled. Suitable for use with the Viewmaster, "Practical Television," "Practical Wireless," and "Wireless World" televisions.

LASKY'S PRICE £8. 10. 0 Carriage 12/6 extra. Outside dimensions of cabinet: 17½in. x 10½in. x 32in. high. Why not convert your table receiver to a console?

TELEVISION SOUND AND VISION ON ONE CHASSIS

Size 10in. x 4½in. x 1in

Made possible by the use of miniature valves.

London frequency. (Can be converted to Holme Moss)

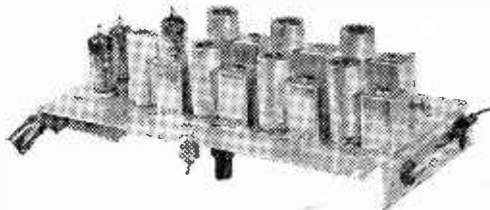

These units are not ex Government, but are brand new manufacturer's surplus. They may be used with any type time base and c.r. tube, are fully assembled and wired. Voltages required:—L.T. 6.3 volts, 3 amps; H.T. 270 volts, 80 m/a.

Valve line-up:—5 6AM6's R.F. amplifiers sound and vision, one common to both. 2 6AL5's sound and vision detectors, 6AM6 video amplifier, 6AM6 sync. sep., 6AM6 sound out put. Send 6d. for a copy of the full data, circuits and photographs dealing with this unit.

LASKY'S PRICE, Less Valves, 95/-

Carriage and packing 3/6 extra.

LASKY'S RADIO,

370, HARROW ROAD, PADDINGTON,
LONDON, W.9. (Opposite Paddington Hospital.)

Phone: Cunningham 1979 and 7214.

Send a 2½d. stamp with your name and address for a copy of our current Bulletin. We have large stocks of new surplus radio components, valves, transformers, etc.,

Hours: Mon. to Sat. 9.30 a.m. to 6 p.m. Thurs. half-day. Our current Bulletin. We have large stocks of new surplus details of which are given in our Bulletin.

RECEIVER TYPE 25. The receiver portion of the TR 1196. Covers 4.3-6.7 Mc/s and makes an ideal basis for an all-wave receiver, as per *Practical Wireless*, August, 1949, issue. Complete with valves type EF36 (2), EF39 (2), EK32 and EBC33. Supplied complete with necessary conversion data for home use, 35-nw condition. Chassis only 8/6.

PLESNEY. 3in. P.M. Speaker with miniature O/Trans., 17/6. W.B. 21in. P.M. 3 ohms, 1/trans., 15/-.

R.3515 I.F. STRIP. A complete I.F. Unit comprising 6 SP91 I.F. Stages, tuned to 13.5 Mc/s, 1 EA50 diode detector and 1 EF36 or EF39 output or video stage. A few modifications only are required to adapt this unit, which will give pictures of extremely good quality. Price, complete with valves and foot-proof modification instructions, is 45/- plus 5/- carriage and packing. Limited quantity only.

5CP1 C.R. TUBES. Brand New and Boxed, 25/- carriage paid.

3 BP1 C.R. TUBE complete with base and shield in holder with leads, 25/- Brand new.

3547- RECEIVERS. Absolutely brand new, in sealed manufacturer's packing cases. Incorporating 15 valves type EF50, 2 of SP91, EF36, EBC33, 3 of EB34. Complete 45 Mc/s I.F. Strip, motor dial and drive, pots, etc., etc., 26 only, plus 10/- packing and carriage. Whilst they last!

MIDGET 0005 mfd. TWO-GANG TUNING CONDENSER. Size only 2½in. x 1½in. x 1½in. Capacity guaranteed, standard length 1in. Spindle, complete with mounting bracket, less trimmers, 6/6, or complete with "built-in" trimmers, 7/6. Each plus 6d. post.

NO. 38 "WALKIE-TALKIE" TRANSMITTER. Complete with throat Mike, phones, junction box and aerial rods in canvas bag. Fred. range 7.4 to 9 Mc/s. All units are as new and tested before despatch. As supplied to Overseas Police Forces. 24.19.6. Carriage 2/6.



5 HARROW ROAD, LONDON, W.2

PADddington 1008/9

0401

GERMANIUM CRYSTALS complete with circuit diagram, 4/6.

MIDGET TWO-GANG .0005 WITH 4W. PUSH BUTTON, 8/6.

RECEIVER R1355 as specified for "Inexpensive Television." Complete with 8 valves VR65, and 1 ea. 5U4G, VU120, VR92, and a copy of "Inexpensive TV." ONLY 55/- (carriage, etc., 7/6).

MOVING COIL METERS, 2in. scale, 0-500 micro-amp., round projecting type, 10/-; 0-50 m.a., panel mounting, 7/6; 0-40 volts, panel mounting, 7/6; 0-20 amps., round projecting type, 7/6; 0-40 150 m.a., double reading, round projecting type, 12/6.

Send stamp for current Component List. Probably the most comprehensive in the trade.

EF50 (VR91) BRAND NEW RED SYLVANIAN, 10/-. Original boxes: British Types boxed, 8/6. Unboxed British Types, 6/-.

I.F. TRANSFORMERS. Manufacturer's surplus, iron-cored, 465 kc/s. Size 4in. x 1½in. x 1½in. Per pair, 8/6 whilst they last.

VIBRATOR POWER UNITS, 2 volt. As for Canadian 58 set. Completely smoothed, output 1.5v. L.T. and 90v. and 180v. H.T. at 35 m.a. Complete in grey metal box. Size 8 x 31 x 41. 50/- only.

METAL RECTIFIERS, S.T.C., 300 volts 75 m.a., 6 - G.E.C., 8 volts 1 amp., 4 - Westinghouse, 12 volts 2 amp., 12/6. Pencil Type E.H.T., 600 v. 1 m.a., 4/7; 1,000 v. 1 m.a., 6/-.

FILAMENT TRANSFORMERS. All Input 200/50 A.C., 6.3 v., 1.5 amp., 7/6; 1granic 6.3 v. 2 amp., 10/-; 6 v. or 12 v. 3 amp., 15/-; 6.3 v. 12 amp., 37/6.

MAINS TRANS. (PARMEKO) 250-0-250, 90 m.a., 6.8 v. 3 amp., 5 v. 2 amp. Input, 110/250, 20/-. Min. Mains Trans. 3½ high by 3 by 2½, fully shrouded, 250-0-250, 60 m.a., 6.3 v. 2 amp., 5 v. 2 amp. 21/-.

SIGNAL TRACER at minimum cost. An easy-to-build unit that can be used for R.F., I.F. and Audio signal tracing, without any switching or tuning. Highly sensitive, easy-to-build, responds to signals picked up from an ordinary receiving aerial. The circuit is that of a high-gain, 3-stage resistance-coupled audio frequency amplifier, with a 5-inch speaker in the Output of the Power Amplifier stage.

We shall be pleased to supply a complete kit for the construction of the above, right down to the last nut and bolt, for the low price of £3/18/6. Complete instructions and circuits are supplied. If preferred, circuit and instructions only can be supplied for 1/6 post free. All items may be purchased separately. This is a highly efficient instrument, and a MUST for every radio man. Completely assembled and tested, ready for use, £5 5/0.

Television at 200 miles

NEW MODEL SC23 TV PRE-AMPS. ALL CHANNELS



- High gain and low noise.
- Customs built to the highest standards.
- Ample bandwidth for good definition.
- Ideal for the "difficult" fringe and ultra fringe areas.
- Each pre-amp. supplied guaranteed to have been "air tested" and to have received both vision and sound at 200 miles using a standard commercial superhet. receiver.
- Models SC22 and SC23 have self-contained metal rectifier power supply, 200/250v. A.C.
- 12 months' guarantee.
- Immediate delivery.

RETAIL PRICE LIST

(Trade enquiries invited)

SC23, new model, £5. 5. 0. SC22, two-stage, £8. 10. 0.
 SC21, two-stage, £6. 6. 0, requires power supply.
 SG12, TV Sig. Gen., £6. 19. 6. PG11, Patt. Gen., £14. 0. 0.

TELEVISION SIGNAL GENERATOR

- Frequency range 40/70 Mics.
- Calibration chart for all Television Channels.
- Modulation on sound and vision optional.
- Sensitive meter fitted for use as grid dip oscillator.
- Ideal for service engineer and experimenter.
- Measures coil, aerial frequencies, etc.
- The only one of its kind on the market.
- Self-contained power supply, 200/250v. A.C.
- 12 months' guarantee.
- Immediate delivery.

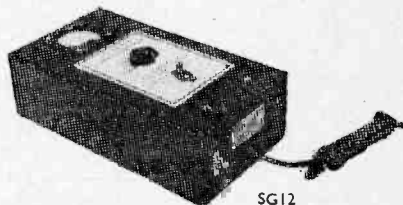

SG12

J. V. RADIO CO.

84, EMBANKMENT ROAD, PLYMOUTH.
 Manufacturers of Television Equipment. Tel. 4737.

OUR T.V. NEWS

Half as much picture again

The 6In. tube VCR97 gives a picture approx. 5in. x 4in. or 20 sq. in. a 7in. tube would give a picture 6in. x 5in. or 30 sq. in. in fact half as much again. We can supply a 7in. tube which has same base and same connections as the VCR97 but requires a little more frame and line amplitude (fluorescence is green). The type number of the tube is CV961. Price is 47/6, plus 2/6 carriage and packing. The tubes are new and unused; the serial number will be entered on your invoice and should a tube give trouble within six months it will be replaced.

FOCUS RINGS

Made by very famous manufacturer, new and unused, 9/6 each. P.M. Type (quick adjustable), 17/6 each.

T.V. FILAMENT TRANSFORMERS

200-240 v. mains input, 2 v., 21 amps., highly insulated secondary for E.H.T. rectifier, 7/6 each.

RDF1 WITH 14 VALVES 49/6

POST 5/-

194 STRIP 45/- POST 2/5

EF50's GUARANTEED NEW— 10/6 EACH

As a result of a large purchase of EF50 (VR01) valves which were to be exported but were never sent, we are able to offer these absolutely new, still in fact in the original cartons. Each one is guaranteed for 6 months from the date of purchase. This valve, as you know, is still one of the best for T.V. work, and is recommended by the designers of the "View-master."

Limited stocks, so order as soon as possible.



To avoid delay address post orders to Dept. 5 of our Ruislip Manor Depot, and include extra 2/6 under £2, 1/9 under £1.

FRUSTRATED EXPORT ORDER

A.C. MAINS

OPERATED 5 VALVE SUPERHET CHASSIS

Completely wired, aligned and ready for immediate operation, covering three wave-bands, 13-37 metres, 37-100 metres and 200-500 metres. A really excellent receiver ideal for new installations or as a replacement chassis in existing radiograms, etc. The set employs a 5-valve line-up either international octal valves 6X8, 6K7, 6Q7, 6V6 and 5Z4, or "E" types ECH35, EF36, EL31 and 5Z4. The overall size is 8 1/2in. deep by 11 1/2in. wide by 11 1/2in. high. The dial size is 6in. by 8in.

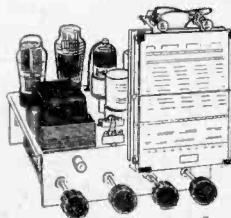

deep by 11 1/2in. wide by 11 1/2in. high.

Note These Points

- (1) Coil assembly can be removed as one unit.
 - (2) Wave-band indicator shows through glass scale.
 - (3) 4-watts output will work 10in. or 12in. speaker.
 - (4) Negative feedback and tone control.
 - (5) Flywheel tuning and large clear dial.
 - (6) Dust-cored coils and I.F. transformers.
 - (7) Sockets for pick-ups and extension speaker.
- Only first-class parts have been used, e.g., mains transformer by "Parmoko," resistors by "Erie," "Wolvyn" and "Moraa" fixed condensers by "Hunts" and "U.I.C.," trimmers and tuning condensers by "Wingrove Rogers," etc., etc.
- Complete chassis less valves, £9 10s. 0d.
 Complete chassis with valves, £11 10s. 0d.
 Complete chassis with valves and 10in. speaker, £12 10s. 6d.
 All plus 5/- carriage and insurance.
 Circuit diagram supplied free with chassis; or separately price 1/6.

R.F. E.H.T. UNITS

Why keep replacing E.H.T. mains transformers? Our R.F. E.H.T. unit will give up to 6 Kv., it is non-lethal and trouble free. Size 4 1/2in. x 3 1/2in. x 4in. Complete, and ready to operate, at 79/6.

152-153 FLEET STREET, E.C.4, and at
 WINDMILL HILL, RUISLIP MANOR, MDDX.



PRECISION EQUIPMENT

Afterthoughts on the Show

THE MARQUIS OF DONEGALL REVIEWS SOME OF THE EXHIBITS

LET us go first for general impressions. For the first time the television receivers seemed to be about equal in number to receivers for sound broadcasting.

Sub-dividing again. There were about as many television sets using projection as there were using direct viewing. Some makers are sitting on the fence, producing both systems as though waiting for the public to swing to one or the other.

The advantage of projection is, of course, that you get a bigger and a flat picture. But a small fly has arrived into that ointment by H.M.V.'s production of a 21in. tube giving a picture approximately 18in. by 14in. H.M.V.'s "balloon" is unpriced; so far as replacement and size go projection still wins. Quality of picture is a matter of opinion and the three-piece H.M.V. containing the 21in. tube costs 540 guineas. It provides remote control for record changing.

The most expensive set in the show was Decca at 757 guineas.

It is one unit. And what a unit! Obviously intended for a palace or baronial mansion.

The Decca provides for L.P. at 33 $\frac{1}{3}$ and has a remote control—the only one I saw—for television.

Those attachable screens that show the TV picture in different colours are disappearing, together with the 9in. screen. The average screen size was 12in.

Nor was there any colour television this time—let alone stereoscopy. I was told that many of the technicians working on these advanced art forms are occupied with rearmament.

I should mention that several makers have announced models that will be easily adjustable to any of the five TV channels now scheduled.

One new type of picture tube is the practically flat glass screen carried on a steel cone. This was shown by English Electric and Mullard. There are also flat-ended tubes by G.E.C., claimed to be notable for stable reception in fringe areas.

For those unfortunate people still condemned to D.C., Murphy have designed a receiver especially for use in D.C. areas.

In common with H.M.V., Murphy now use only aluminised cathode-ray tubes; Ferguson have a push-pull output for sound.

The consoles of super-sensitivity designed by Vidor for remote regions have 12in. tubes and the Sobell has the distinction of being contained in the largest single plastic moulding yet made on a production scale in Britain.

Newcomers to the industry are Stella Radio and Television who are connected with Philips. They showed

two radios and two television sets. Their cheapest exhibit was an all-wave table model at the attractive price of 20 guineas tax paid.

I saw many new ideas in television aerials, such as one by Belling and Lee, designed for mounting on window-frames. That looks as though our old friend the "H" may be on its way out. But snobbery dies hard in semi-detached villas.

Before we leave television, I would like to mention the "Spot-Wobble," a device shown by Ekco in several direct-viewing models and intended to hide the line-structure unavoidable in TV [Originally sponsored by PRACTICAL TELEVISION—Ed.].

It is claimed that Ekco "Spot-Wobble" makes it possible to "smooth out" the picture, the lines of which are more evident on larger screens. This is achieved by deflecting the spot in a vertical plane as it forms each horizontal line on the screen, giving the effect of merging the lines to a point where they cannot be distinguished.

Undoubtedly both in television and sound, prices have tended to rise since Castle Bromwich last year. This is hardly surprising in view of the increase in purchase tax; in fact, as the manufacturers have obviously concentrated on improving both performance and appearance, I was surprised that they have not risen more.

The "furniture," especially some of the walnut—and some oak—is really superb. Even the cheapest sets are good-looking, in seemingly hundreds of different shades and shapes of plastic and metal. The little portables come in more disguises than ever before.

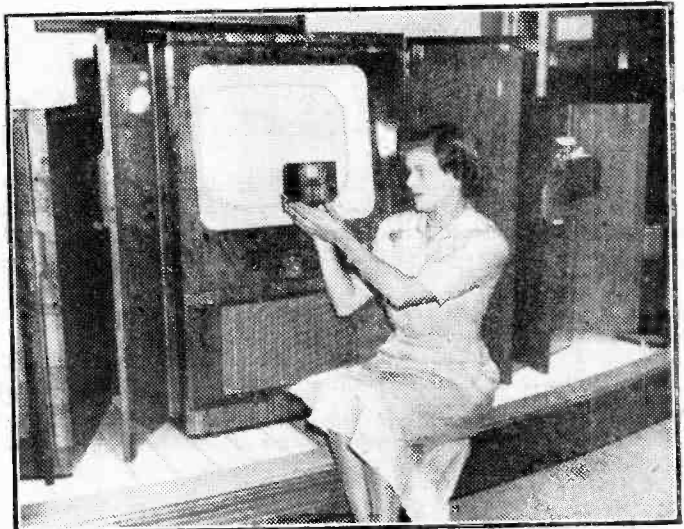

The largest and smallest.—a 21in. and a 1in. receiver shown by H.M.V.

Invicta, for instance, comes in a little tartan- or plain-coloured handbag to match almost any woman's outfit. A Ferranti portable emerges from the type of small attached-case that a top freemason takes with him to his lodge.

Other items that seem to have increased since last year were the amusing nursery-rhyme sets for the children and the number of zip-up weatherproof cases to fit various portables.

The Roberts struck me as one of the most desirable in the show. The R.M.B. model at 25 guineas (tax paid) is an all-wave receiver—and very nice, too. But the "Junior" at £21 Os. 6d., with its waterproof case included, is a little beauty. It receives medium and long, and comes in red, blue or green. The R.M.B. is battery and mains, whereas the "Junior" is battery only.

Regarding components and accessories, we do not doubt that the National Physical Laboratory is right, and that the Amplion "Activette" really does make dry batteries last five times as long as normal. It uses the mains, and I cannot recall any other device for which a similar claim was made.

To operate the device to the maximum the user should "top-up" his batteries every night. It operates for H.T. from 45 to 90 volts and 1.5 L.T.

But one of its greatest uses is for the deaf. A special "Activette" will cope with any known form of deaf-aid, the makers claiming that this model saves 5s. in every 6s.

Apart from commercial exhibitors, the Navy was represented chiefly by an exhibit depicting the use of Radar in the defence of a cruiser. This was ingeniously shown to a visitor standing "on the bridge."

To show the development of signalling, the Army showed that the Greeks had a word for it in 150 B.C. ! Some of the electrical signalling equipment used in the Crimean War provided a fascinating side-line.

The R.A.F. were prepared to show the visitor how the presence of hostile aircraft is shown on the screen to the night-fighter Radar observer. The actual apparatus used is the air-interceptor Mark 10, as used in our latest night-fighter, the Gloster N.F. Mark 11. They also showed Rebecca and Gee blind-landing and navigation aids with their latest improvements.

Not to be out-done, the Ministry of Civil Aviation showed the model of London Airport as it will be when completed, which has just come from the Paris Aviation Salon. The model is 8ft. by 15ft., a scale of one-in-1250. Ingeniously, conditions changed from good to bad visibility at night and the general flood-lighting of the airport was most effective. When it is finished, the length of London Airport will be the same as from the Tower of London to the Marble Arch.

The G.P.O. had two large stands with an enquiry bureau to help visitors with their interference problems. In fact, emphasis was laid on this angle including the showing of the type of receiver used by P.O. engineers for the detection of nuisances. Another part of the stand showed the teleprinter automatic switching system now operating in a fair proportion of the country. This means that an operator in one telegraph office can dial any other office in the system without the intervention of a junction.

It was obvious that recording has hit the British home. In future sister will never be safe from the inveterate small brother when she brings her young man home for a nice talk-and-tickle on the sofa. The little beast laughing his head off in an adjoining room will play the whole thing back to her the next morning !

I saw no wire recorders, and indeed tape seems to have finally won the battle, although my own wire machine is

still doing excellent service. Interesting tape recorders for the home were shown by Simon Sound Service and others. As to disc recording, I particularly liked Sugden's "Varigroove" which cuts 78 or 33½ and between 100 and 300 lines per inch.

On the way out we noticed the impressive stand displaying technical publications by Messrs. George Newnes, Ltd. These cover so wide a range for the benefit of beginner or expert that it is impossible to pick out a few. The same, I may say, applies to the books, also displayed, from horology to radio, of the incredible F. J. Camm.

BUILDING THE "PRACTICAL TELEVISION" TELEVISION RECEIVER For A.P., Sutton Coldfield or Holme Moss

A large number of readers unable to obtain back numbers of the issues containing the series of articles on the construction of the "Practical Television" television receiver, have asked us to reprint these articles in book form. This has now been done, and copies may be obtained from or through any news-agent, or for 3s. 9d. by post from us.

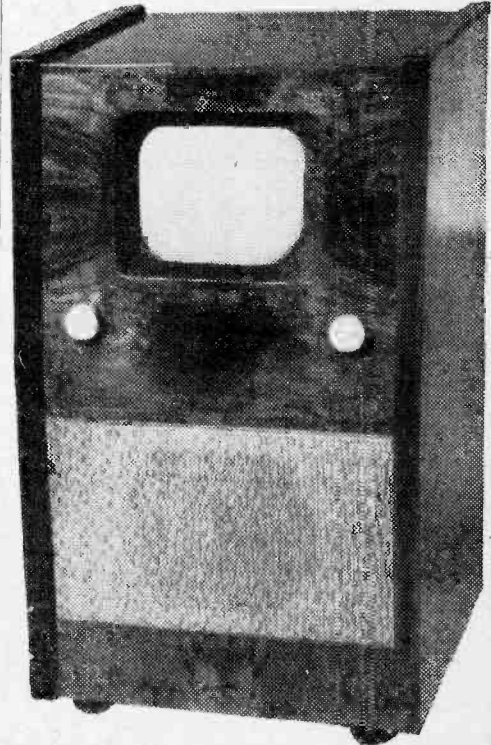

Orders should be addressed to The Publisher, Book Dept., George Newnes, Ltd., Tower House, Southampton Street, Strand, W.C.2. Printed on good quality paper, this 32-page book gives complete stage-by-stage instructions for the construction of this highly efficient 18-valve television receiver.

In order to secure a copy of this limited edition readers should place their orders without delay.

A full-size set of blueprints is available at 10s. 6d. for three sheets.

ARTHURS HAVE IT!

LONDON'S OLDEST RADIO DEALERS
LARGE VALVE STOCKS

AVOMETERS IN STOCK

Avo Test Meters and Signal Generators and Taylor Meters.
 Leak Point Amplifiers. Chapman Tuning Unit.
 Crystal and Moving Coil Mics.
 Decca Replacement Heads and Pickups.
 Goodman's Axiom 150 Speakers.

COSSOR DOUBLE BEAM OSCILLOSCOPE £85 0 0
 PHILIPS PHILISHAVE (Complete in pouch) 6 6 0
 Wire-wound volume controls 7 0

LATEST VALVE MANUALS

JUST PUBLISHED "Osram," 5/-.

MULLARD 5/- each. BRIMAR TELETUBE & Radio, 4/- each.
 MAZDA 2/- each. POST 6d. EACH EXTRA.

TELEVISION SETS, WIRE AND TAPE RECORDERS
ALWAYS IN STOCK.

Goods offered subject to price alterations and being unsold.

Arthurs Est. 1919
first

PROPS: ARTHUR GRAY, LTD.

OUR ONLY ADDRESS: Gray House,

150-152 Charing Cross Road, London, W.C.2

TEMPLE Bar 5833/4 and 4765 WRITE FOR LISTS
 TELEGRAMS—"TELEGRAY, WESTCENT, LONDON"
 CABLES—"TELEGRAY, LONDON"

Are you a viewer with vision?

If so, you will appreciate the wisdom of insurance to cover your TV installation. You might be held responsible, for instance, if your aerial collapsed and caused serious or even fatal injury to someone or damaged your neighbour's property. These liabilities and other risks, such as accidental breakage (but not electrical breakdown or burn-out) of the expensive cathode tube, can all be covered



FOR AS LITTLE AS 7/6 TO 12/6 A YEAR under the Norwich Union's special Television Insurance.

Send the coupon NOW for full details of Norwich Union Television Insurance or ask for them at our nearest Branch Office (for address, see Telephone Directory).

NORWICH UNION

INSURANCE SOCIETIES

10-18, Surrey Street, Norwich, Norfolk



Please send me, without obligation, full details of your special Television Insurance.

Name

Address

P.T.4

Speed-up
SOLDERING
with



SOLDERGUNS

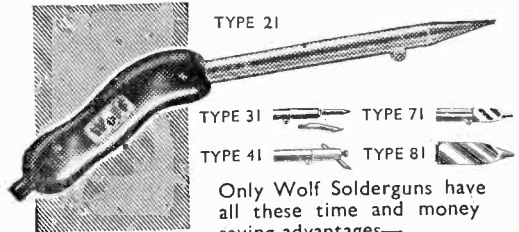

TYPE 21

TYPE 31 TYPE 71

TYPE 41 TYPE 81

Only Wolf Solderguns have all these time and money saving advantages—

Off-straight Easy-grip Handle · Perfect Control · Low Current Consumption · Models for every purpose from Fine Instrument to Heavy Industrial Soldering · Localised Heat · Maintains Correct Heat · Quicker Heat-up

AUTOMATIC SOLDERING

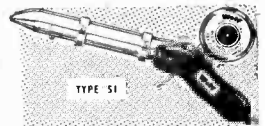

TYPE 51

Win new efficiency and economy with Wolf Automatic Soldergun. Its auto-feed, trigger solder-feed action and perfect balance make it indispensable to all modern assembly.

SOLDERING IRONS

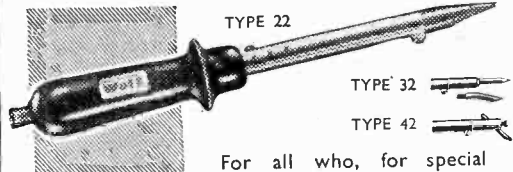

TYPE 22

TYPE 32

TYPE 42

For all who, for special reasons, prefer the conventional straight type handle. Identical as regards elements and bits to Wolf Solderguns but with round hard wooden handle with heat deflecting skirt.

It pays to Solder with **Wolf**

ELECTRIC SOLDERGUNS & SOLDERING IRONS

★ Obtainable from all high class stockists and ironmongers

WOLF ELECTRIC TOOLS LIMITED · PIONEER WORKS

HANGER LANE · LONDON · W.5 Telephone: PERIVALE 3631-4

D. COHEN

Radio and Television Components

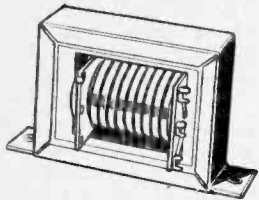

Line and E.H.T. Transformer 5-7 kV., removed from chassis, guaranteed, **9/6**

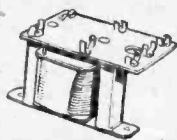

Smoothing choke 150 mA 2 Henry **3/6**



Frame oscillator blocking transformer **4/6**

Line and frame scan coils, removed from chassis, guaranteed. Low Imp. Line, High Imp. Frame, **6/6**

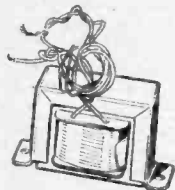

Heater transformer Pri. 230-250 volt, Sec. 2 volt 2 amp. **5/-**

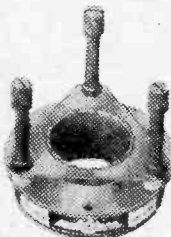

P.M. Focus Unit. Any 9in. or 12in. tube, except Mazda 12, state tube. **12/6**

P.M. Focus Unit for 12in. Mazda **15/-**

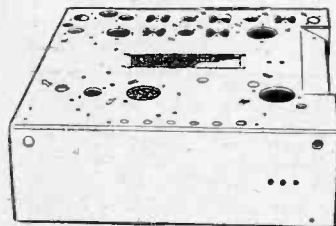

T.V. Chassis, could be adapted for use with the above components. Size 9 1/2 x 9 1/2 x 3 **3/-**

The above components are a very famous T.V. manufacturer's surplus, whose name will be supplied on request.

- 5in. White rubber mask with armour-plate glass... .. 10/-
- 12in. Rubber mask with armour-plate glass... .. 15/-
- 15in. Rubber mask 15/-
- 12in. Armour-plate glass... .. 4/-
- 5in. Armour-plate glass... .. 3/-

Mains trans., could be used in the Viewmaster. Input 200/250 H.T., 280 volt, 360 mA. 4 volt 3 amp., 4 volt 3 amp., 2 volt 3 amp., 2 volt, 3 amp., 10/- plus 1/6 post and packing.

TERMS OF BUSINESS: CASH WITH ORDER
DISPATCH OF GOODS WITHIN 3 DAYS FROM RECEIPT OF ORDER.

Orders under £2 add 1/6. Under £1 add 1/- post and packing.

All enquiries and lists, stamped addressed envelope

23, HIGH ST., ACTON, W.3.
(OPPOSITE GRANADA CINEMA) Acorn 5901

For T.V. Constructors

I.F. STRIP TYPE 194.—As reviewed in October issue of P.T.V. An easily modified I.F. Strip which gives first class results. Readily adaptable into any layout, measuring only 18in. x 5in. x 5in. Complete with 6 valves VR6, 1 VR2, and 1 VR59 or VR56, and mod. data. BRAND NEW. ONLY 45/- (postage, etc., 2/6).

R.D.F.1 RECEIVER (ZC 13312).—Now under review in this journal for conversion into a two-channel Television Receiver. In excellent condition and complete with 14 valves as follows: 5 of SP6L 2 of P6L 3 of EA30, and 1 each CV63, EB31, EC52, 5Z4. ONLY 49/6 (carriage, etc., 5/-).

RECEIVER R1355.—The very popular unit recommended for "Inexpensive TV". Complete with 8 valves VR66, and 1 each 5U4G, VU120, and VR92. ONLY 65/- (carriage, etc., 7/6).

EHT TRANSFORMER FOR VCR97 TUBE. with 4v. for tube heaters and 4v. tapped, 2v. for EHT rectifier. ONLY 32/6 (postage 1/6).

EF50 (VR91) VALVES.—British 6/6, American Red Sylvantia 8/6, Ceramic valve holders for these 10d.
6in. MAGNIFYING LENS FOR VCR97 TUBE.—First grade oil filled. ONLY 25/- (postage 1/6).

PLESSEY P.M. SPEAKERS.—6in. with transformer 14.6, 9in. less transformer 14/6 (postage 1/6).

CHOKES.—2CH 80 120 ma. 6.6. 5H 200 ma. 6. (postage 1/-).

Cash with order, please, and print name and address clearly.

U.E.I. CORPN. The Radio Corner, 138, Gray's Inn Road, London, W.C.1. (Phone TERMINUS 7937).
Open until 1 p.m. Saturdays, we are 2 mins. from High Holborn (Chancery Lane: Str.) or 5 mins. by bus from King's Cross.

SPECIAL VIEWMASTER OFFER

The complete set of chassis comprising:—
1 Sound and Vision chassis } with valveholders
1 Time base chassis } assembled

Side supports, valve screen and sound chassis screens.
Usually 50/-, Our price, BRAND NEW **39/6** (Post & pkg. 1/6)

We regret that it was incorrectly stated in our last advertisement that manufacture of Viewmaster parts had ceased. Our statement was intended to refer only to the availability of our own supplies.

MAGNETIC RECORDING ENTHUSIASTS!

BSR INDUCTION MOTORS Type SR2

Medium power motor for take-up spool drive where fast forward facilities are not required. 25/- each.

Type SRI. A motor of same power as famous FP10, for feed spool operation. Fast rewind. Also for take-up spool and fast forward facilities. High stray magnetic field; not recommended for capstan drive. 32/- each.

Type FP10. Minimum stray magnetic field. Silent, almost vibration-free. For capstan drive, 38/- each.

TAMSA MAGNETIC RECORDING HEADS

Recording playback heads for outstanding performance and first class frequency response with good quality recording tape, e.g., Durex. Permits TWIN TRACK RECORDING and saves tape cost. Record/playback head set to very fine limits; gives extended high frequency response. Perfect alignment of face of head to tape; high transfer efficiency. HIGH IMPEDANCE. No transformers needed to couple to amplifiers; one source of hum pick-up completely eliminated. RECORD/PLAYBACK HEAD £2.19.6. ERASE HEAD, £2.19.6.

TAMSA OSCILLATOR COILS

For single valve-circuits (6V6). Output sufficient to erase high co-ersivity tapes. Good wave form leaves tape perfectly silent. Complete with circuit diagram and fixed tuning condensers. Only suitable for use with TAMSA high impedance heads. 10/6 each.

MOS MAIL ORDER SUPPLY COMPANY
The Radio Centre (Dept. PT II)
33 Tottenham Court Road, London, W.1.

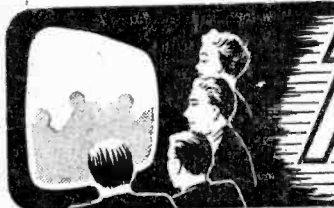

TELENEWS

Scarcity of Receivers?

WHEN the new transmitter opens at Holme Moss on 12th October, the total number of possible viewers will be increased by 12,000,000. Experts predict that 250,000 receivers will be needed to cope with the new demand from the North and yet another 250,000 when the Kirk O'Shotts transmitter comes into operation next spring.

These estimate figures are regarded by some manufacturers as being too low and, they believe, by the time the transmitter at Wenvoe is completed midway through next year, a grave shortage of sets may have arisen.

World's First Wireless College

AT Frinton-on-Sea, on 12th October, 1901, the first wireless college in the world was opened.

It was moved to the Chelmsford works in 1904 and was re-established in 1920 at its present site in Arbour Lane.

Soon to celebrate its 50th birthday, the college is regarded as one of the finest wireless technical colleges in the world.

Authorised Amateur Television on 70 cms

FOLLOWING recent discussions between the Rt. Hon. Ness Edwards, M.P. (Postmaster-General), and the Radio Society of Great Britain, the G.P.O. have now told the Society that amateur (vision) wireless station licence holders may transmit television signals on frequencies within the band 425-455 Mc/s providing there is no interference with other services.

A maximum input power of 25 watts will be permitted.

Cinema-Television

MR. J. ARTHUR RANK, in his statement to shareholders, said that the activities of Cinema-Television Ltd. fall into two parts; first, the production of specialised tubes for television receivers and for industrial and other purposes, which business is developing on satisfactory lines.

The Editor will be pleased to consider articles of a practical nature suitable for publication in "Practical Television." Such articles should be written on one side of the paper only, and should contain the name and address of the sender. Whilst the Editor does not hold himself responsible for manuscripts, every effort will be made to return them if a stamped and addressed envelope is enclosed. All correspondence intended for the Editor should be addressed to: The Editor, "Practical Television," George Newnes, Ltd., Tower House, Southampton Street, Strand, W.C.2.

Owing to the rapid progress in the design of wireless apparatus and to our efforts to keep our readers in touch with the latest developments, we give no warranty that apparatus described in our columns is not the subject of letters patent.

Copyright in all drawings, photographs and articles published in "Practical Television" is specifically reserved throughout the countries signatory to the Berne Convention and the U.S.A. Reproductions or imitations of any of these are therefore expressly forbidden.

The second is the development of a large-screen television system. Little progress has been made during the year owing to inability to use this screen in public due to the

fact that they are unable to secure the necessary experimental licences from the appropriate authorities.

The Beveridge Committee of Enquiry into the BBC charter has reported during the year and H.M. Government have recently issued a White Paper in connection therewith. Unfortunately, the latter does not deal with the requirements of the cinema industry for large-screen television. Negotiations are taking place and it is hoped that an understanding will eventually be reached between all interested parties.

Shortage of Service Engineers

MR. L. A. SAWTELL, commercial manager of the Entertainment Valve Division of Messrs. Mullard Ltd., recently spoke of a very real danger of a shortage of trained service engineers in the years to come unless service work becomes much more mechanised and the present generation of engineers is prepared to continue in their work to a greater age than that normally considered to-day as the time of retirement. This warning was made at the occa-

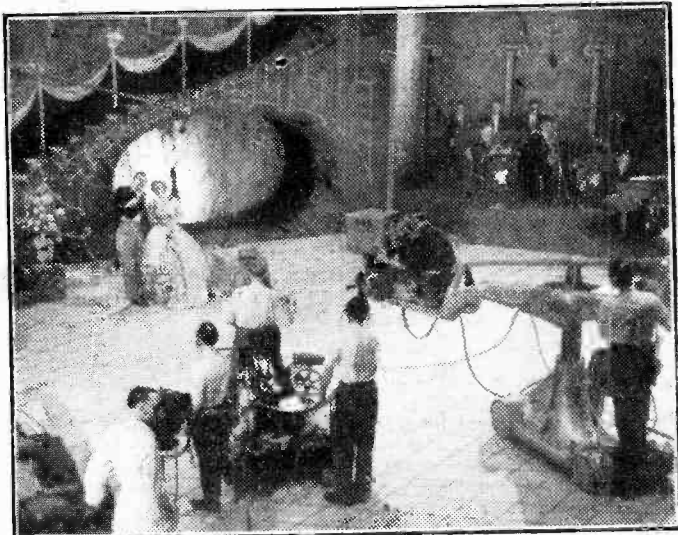

A view of the studio at Earls Court showing one of the new and elaborate camera "dollies" in action.

sion of the annual dinner of the Institute of Practical Radio Engineers at the Connaught Rooms on 5th September, 1951.

The Television Trend

DR. A. R. A. RENDALL, B.Sc., Ph.D., M.I.E.E., head of the designs department of the BBC, outlined in his speech at the annual dinner of the I.P.R.E. the probable future programme of the Corporation's television transmission extensions and called attention to the rapid growth in numbers of the viewing public even with the modified programme of new transmitters which had been enforced by the existing situation. Dr. Rendall emphasised the necessity of the coming generation of service engineers making every possible use of facilities for extension of their knowledge and interchange of information such as was provided by the Institute of Practical Radio Engineers, which has now reached its fifteenth birthday.

Broadcast Receiving Licences

STATEMENT showing the approximate numbers issued during the year ended 31st August, 1951.

Region	Number
London Postal	2,359,000
Home Counties	1,656,000
Midland	1,757,000
North-eastern	1,921,000
North-western	1,621,000
South-western	1,074,000
Welsh and Border Counties	733,000
Total England and Wales	11,121,000
Scotland	1,113,000
Northern Ireland	210,000
Grand total	12,444,000

The above total includes 933,050 television licences.

Additional Link

ON 5th September the long lines department of the American Telephone and Telegraph Company placed in service a southbound television channel from Detroit to Toledo, Ohio.

Before the opening of the new channel, which is provided by coaxial cable, Detroit was served by three northbound television channels through radio-relay facilities, the first two being in operation since September, 1948, the other since May, 1949.

The Bell System's inter-city television network now totals nearly

18,000 channel miles, including the latest addition.

By the end of this month it is anticipated that over 23,500 miles of channels will be in commercial service, serving 46 cities with 85 television stations.

New Type Emitron Links

IN two Emitron Microwave Links, recently delivered to the BBC, new type klystron valves are incorporated which enable the link transmitters to operate on powers of the order of 3-5 watts.

Development of the special valve

officials to areas north and south of the Tyne, the testing of receivers when local hospital machinery is working and when not, and manufacturers changing the frequency of their machines.

With all possible interference eliminated, however, reception in the North-east from Holme Moss will be far from perfect and protests continue to be voiced over the ceasing of work on the Pontop Pike transmitter.

Programmes from the Deep

AS soon as the cost is approved by the Treasury, an underwater television station is to be set up on a marine science research ship belonging to the Marine Laboratory, Millport, Firth of Clyde.

Thus the BBC hope to televise live programmes from deep down under the water, always providing that vision is moderately clear and not murky. Remote control-operated cameras will be used and possible programmes may include underwater welding and close-ups of divers at their work.

New Plant

IT was recently disclosed by an official of the company that production is expected to begin in a few months at a new Philips radio assembly plant in Israel.

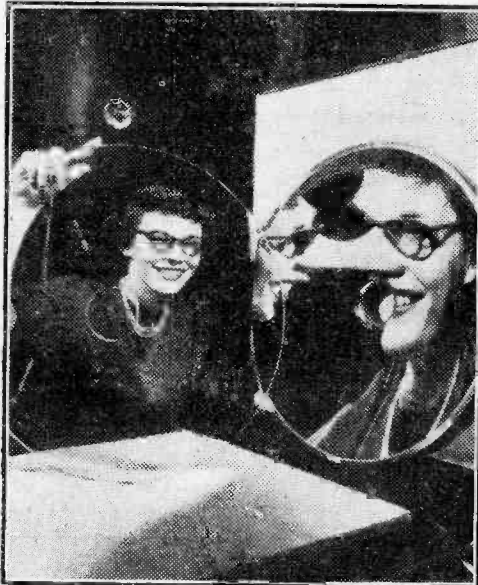

The projection of improved 15 by 20-foot television pictures on cinema screens is made possible by a new image-correcting glass lens developed by the American Optical Company and shown here in front of the young lady. The spherical mirror at right, which shows the lady's face, magnifies TV images and projects them on to the screen. Distortions introduced by the magnifications are corrected by the lens.

is the result of three years' thorough research and its success is illustrated by the fact that successful working of these links at full operational reliability has been obtained at distances of more than 45 miles, under far from excellent conditions.

Interference Drive

RECEPTION on Tyneside has been hazy since the tests began several weeks ago, and this has resulted in a drive to stop almost all interference in the district within a few weeks.

Efforts include visits by G.P.O.

Service for Ships

THE idea of hiring television receivers by some shipping companies for their ships in dock in London is expected to extend to Merseyside now that Holme Moss is in operation.

Seamen are also anxious to have telephones installed on board while in port in order to have a close link through the G.P.O. with their relations and friends.

Trials in Switzerland

IT is understood that television trials will begin late this year at Basle, Switzerland.

PREMIER RADIO CO.

B. H. MORRIS & CO. (RADIO) LTD.

HEAD OFFICE & MAIL ORDER, (Dept. P.T.) 207, EDGWARE ROAD, LONDON, W.2
OPEN TILL 6 P.M. SATURDAYS Phones: AMBASSADOR 4033 & PADDINGTON 3271/2
TERMS OF BUSINESS:—CASH WITH ORDER OR C.O.D. OVER £1. Please add 1/6 for post orders under 40/-
 1/- under 20/- Over 40/- carriage free unless otherwise stated.

BALANCED ARMATURE, LOW RESISTANCE HEADPHONES, Type 1. 5/11 set.

BALANCED ARMATURE, LOW RESISTANCE HEADPHONES, Type 2. 7/11 set.

HIGH RESISTANCE HEADPHONES, 12/6 set.

LIGHT-WEIGHT HIGH RESISTANCE HEADPHONES, 14/6 set.

MOVING REED HEADPHONES, Type 5, 8/11 set.

TANNAY HAND MICROPHONES, with switch in handle, 4/11. Post and insurance 2/-.

BRAND NEW R1155 RECEIVERS, in original cases, complete with 10 valves, £12/10/-, 7/6 Packing and Carriage.

BRAND NEW R1355 RECEIVERS, in original cases, as specified for the "Inexpensive Television," complete with 11 valves, £2 15/-, 7/6 Packing and Carriage.

GRAMOPHONE AMPLIFIER KIT Consists of complete Kit of Parts for a 21-watt mains-operated 2-stage Amplifier for use with any type of pick-up. Volume and tone controls are incorporated. Output impedance is 3 ohms.

Cat. No. AMP147. Price complete, 59/6. For 200-250 v. mains, with valves and diagrams.

CRYSTAL MICROPHONE An entirely insulated crystal microphone which can be safely used on A.C./D.C. amplifiers. HIGH impedance. No background noise, really natural tone. The ideal Mike for tape, wire and disc recording and sound projectors. Price 22/6.

IMPORTANT ANNOUNCEMENT: Premier Radio Co. no longer have a branch at Fleet Street, London, E.C.4. Premier products can be obtained at our only address, 207, Edgware Road, W.2

SPECIAL OFFER OF ADMIRALTY REFLEX-RE-ENTRANT P.A. LOUD-SPEAKERS, v. coil 7 ohms. Matching transformers 1.5:1 and 6:1 ratios with vol. control at max. Very sensitive and directional. Single unit, 55/-, Twin units, 75/-, Carriage and packing, 5/-.



SENSATIONAL OFFER

The famous Dulci Midget Receiver for use on either A.C. or D.C. mains, 200-250 volt. This is a 2-waveband 4 v. Superhet Receiver covering the short waveband from 13.6 metres to 50 metres, and the medium waveband from 200-550 metres. Can be supplied in either ivory or brown bakelite cabinet.

Size 7 1/2 in. length, 6 in. height, 5 1/2 in. depth. This receiver is fully covered by the manufacturer's guarantee.

Price £8 15/0, carriage paid. THIS OFFER CANNOT BE REPEATED

NEW BABY ALARM KIT

A complete Kit of Parts in plastic cabinet to construct a device to enable baby's cries or even breathing to be heard in any selected room in the house. Consists of a 2-valve amplifier (mains operated) with midget telephones which are used as microphone and loudspeaker. May be left permanently connected. Complete with valves, circuit and instructions for 200-250 v. A.C. mains, 55/-.

PREMIER SUPERHET COILS, 16-50, 180-550, 800-2,000 metres. Set, with circuit, 10/6.

G.E.C. GERMANIUM CRYSTAL DIODES. Wire ends. Midget size. The ideal crystal detector, 4/6.

EX-U.S.A. U.H.F. AERIAL, with untuned detector stage consisting of VR92 valve, etc. Brand new in carton, 5/-.

TUNING CONDENSERS

4-Gang .0005 mfd. Ceramic insulation. 1 in. spindle, 5/-, 3-gang .0005 mfd., 1 in. spindle, 7/6.

CARBON HAND MICROPHONE, super quality, with switch in handle. Type 5A, 3/11.

THREE-PIECE AERIAL

EX-U.S.A. copper-plated steel, highly flexible with non-stick screw joints, tapering 3/8 in. to 1/8 in. Brand new, in container, 6/9, packing and carriage 1/6. Insulated base, 2/6.

SOLONS FOR ESSENTIAL JOBS!

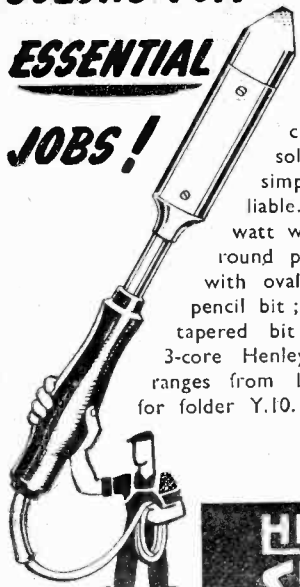

Use SOLONS for the jobs that matter —this modern precision tool makes soldering speedier, simpler and more reliable. 5 models: 65 watt with oval tapered and round pencil bit; 125 watt with oval tapered and round pencil bit; 240 watt with oval tapered bit; each with 6 feet 3-core Henley flexible. Voltage ranges from 100 to 250. Write for folder Y.10.



W. T. HENLEY'S TELEGRAPH WORKS CO. LTD.
 51-53 Hatton Garden, London, E.C.1.

SUCCESS?

In Radio, Television, and Electronics, there are many more top jobs than engineers qualified to fill them. Because we are part of the great E.M.I. Group we have first-hand knowledge of the needs of employers, thus our Home Study courses are authoritative and based upon modern industrial needs. Alternatively, our courses will prove equally valuable to you in furthering your hobby.

POST THIS COUPON NOW

E.M.I. INSTITUTES, Postal Division, Dept. 133, 43 GROVE PARK ROAD, CHISWICK, LONDON, W.4.

Please send, without obligation, your FREE BROCHURE. (I have marked the subjects which interest me).

- Mechanical Eng. Electrical Eng. Draughtsmanship.
- Radio. Television. Production Eng. Automobile Eng. Aeronautical Eng. General Cert. of Education (Metric). Civil Service.

Also courses for A.M.I. Mech.E., A.M.I.C.E., A.M.Brit.I.R.E., A.F.R.Ae.S., CITY and GUILDS EXAMS. in Mech. Eng., Elect. Eng., Telecommunications, etc.

Other Subjects
 NAME
 ADDRESS

E.M.I. INSTITUTES—The College backed by an Industry

CLYDESDALE

Bargains in Ex-Services Radio and Electronic Equipment

INEXPENSIVE T.V. ITEMS

THE R3170A RECEIVER UNIT

A 16-valve radar receiver chassis, with 5 I.F. stages, R.F. section, high cycle power section. Valve types 8 EF50, 2 EA50, EC52, 5Z1, VU11, CV118. Housed in metal case, 18in. x 9in. x 8in. Finish grey.
CLYDESDALE'S PRICE ONLY £4.12.6 CARRIAGE PAID

THE R3601 RECEIVER UNIT

A 14-valve dual chassis radar receiver, with 85 Mc/s and 45 Mc/s I.F. strips, R.F. section, high cycle power section. Valve types, 5SP61, 4EA50, 2EF54, EF50, EC52, 6V6 and VU39A rectifier, plus antenna switch, relay, etc., etc. Housed in metal case, 18in. x 9in. x 8in. Finish light blue.
CLYDESDALE'S PRICE ONLY £4.12.6 CARRIAGE PAID

NEW LIST NO. 8.

Giving details and illustrations of ex-Service items and cancelling all previous lists and supplements. Ready November. Price 1/6. Price credited on first purchase of 10/- or over.

CAT. NO. H524—INDICATOR UNIT TYPE 6. IN MAKER'S ORIGINAL CASE

Containing a VCR97 Cathode Ray Tube, with mu-metal screen, 4 VR91's (EF50), 3 VR54's (EB34), various w.w. pots., switches, H.V. conds., resistors, etc., built in metal chassis to fit into metal box, 18in. x 8 1/2in. x 7 1/2in. All controls are brought to front panel beside viewing screen.
CLYDESDALE'S PRICE ONLY £4.9.6 CARRIAGE PAID

Order direct from:

CLYDESDALE SUPPLY CO. LTD.

2, Bridge St., Glasgow, C.5. Phone: SOUTH 2705, 9
Visit our Branches in Scotland, England and N. Ireland.

Aerial Masts. In 3ft. 6in. sections plus 6in. sleeve, 2in. dia. Push fit, extendable to any length. In lightweight steel, copper plated. Ideal for TV beams, 5 sections for 29 6". Carr. paid.
H.T. Transformers. Originally high cycle, but with 30 v. 50 cps. input gives approx. 1,500 v.; with 230 v. input in series with a 2 mfd. condenser gives approx. 2,400 v.; with a 4 mfd. cond. an output of 3.3 Kv. can be obtained. 5 - each, post paid.

Television Chassis. 16in. by 12in. Containing 7 octal holders, 3 of B.7.G and 8 B.8.G valveholders. Ex manufacturers' stock. All necessary holes drilled and sections cut. The ideal layout as designed by experts. A real snip at 5/- each, plus 1/6 carr. **Indicator Units Type 6.** Containing the V.C.R.97 CRT, 4 E.F.50 valves, pots., cond., res., etc. A few only at £3 10s. each, plus 5/- carr.

Rubber Masks for 12in. CRT. Standard type. Brand new in moulded rubber. Price 9/6 each.
Armoured Glass. To suit the above masks. Size 10 1/2in. x 13in. Price 6/- post free.

Receiver Type 181. Contains CV66 G.G. triode, 2 VR156 and 1 VR137 valves. Suitable for building a sound or vision converter with a low noise level. Special price, 21/- each.

COMPONENTS FOR THE CONSTRUCTOR.

Condensers. 0.01 mfd. 4 kV. working. Black bakelite tubular. 9 - doz.

Plugs and Sockets. Belling-Lee type 7-pin, male part chassis mounting. 2 - per pair. 4-pin Army type, with location. 1/6 per pair.

Iron Dust-cored Coil Formers. Containing standard size dust-cores. 2/6 per doz.

Eye Plugs and Sockets. At 6/- per doz. pairs.

Polythene Sleeving. 3 mm. int. dia., 8 yds. for 1'.

filament Transformers. Tapped input 200 to 250 v. 50 cps. Output 6.3 v. 6 amps., 6.3 v. 3 amps., 2 v. 2 amps. Limited quantity only at 13/6 each. Also 230 v. input, 6.3 v. 3 amps. (Tapped 5v.) output at 7/6, post paid.

Amplifier A1271. In black case, with E.F.36 valve, 1,000 ohm relay, 2 audio trans., etc. As advertised at 15/- each. Our price 8/6 each.

Rectifiers. Selenium Sen-Ter-Cell Type. Half-wave: 16 v. at 5 amps., large fin type, at 18/6 each; 12 v. at 5 amps., large fin type, at 12/6 each; 16 v. at 3 amps., at 15/6 each; 12 v. at 3 amps., at 10/6 each.

PLEASE NOTE OUR NEW ADDRESS

C. MARKS & CO.

88, Commercial Street, NEWPORT, Mon.

Phone 4711.

Also at 25, Wyndham Arcade, Cardiff.

(All Mail Orders and Enquiries to NEWPORT, please.)

G.E.C. GERMANIUM CRYSTAL DIODES

LATEST, SMALLEST
SUPREME CRYSTAL DETECTOR

Midget Size, 5/16in. x 3/16in.
Wire Ends for Easy Fixing.

4/6 each, postage 21d.

Technical Details and Selected Types available.

SILICON CRYSTAL VALVE

3/6 each, postage 21d.

Fixing Brackets 3d. Extra.

COPPER INSTRUMENT WIRE

ENAMELLED, TINNED, LITZ.
COTTON AND SILK COVERED.
Most gauges available.

B.A. SCREWS, NUTS, WASHERS,
soldering tags, eyelets and rivets.
EBONITE AND BAKELITE PANELS
TUFOLOM ROD, PAXOLIN TYPE
COIL FORMERS AND TUBES.
ALL DIAMETERS.

Latest Radio Publications.

SEND STAMP FOR LISTS.

TRADE SUPPLIED.

POST RADIO SUPPLIES

33, Bourne Gardens,
London, E.4.

Pre-Amplifier Transformer. Prim. 200 250 v. Sec. 230 v. at 30 mA. 6.3 v. at 1.5/2 amps., 23/-

HS150. 350-0-350 at 150 mA.

6.3 v. 3 amps. C.T. 5 v. 3 amps.

Half shrouded, 30/9.

FS43. 425-0-425 at 200 mA. 6.3 v.

4 amps. C.T., 6.3 v. 4 amps. C.T.,

5 v. 3 amps. Fully shrouded, 51/-

F35X. 350-0-350 v. at 250 mA.,

6.3 v. 6 amps., 4 v. 8 amps., 4 v. 3

amps., 0-2-6.3 v. 2 amps. Fully

shrouded, 71/6.

FS160X. 350-0-350 v. 160 mA.

6.3 v. 6 amps., 6.3 v. 3 amps., 5 v. 3

amps. Fully shrouded, 45/-

FS43X. 425-0-425 v. 250 mA. 6.3 v.

6 amps. 6.3 v. 6 amps. 5 v. 3 amps.

Fully shrouded, 69/-

FS50. 450-0-450 v. 250 mA. 6.3 v.

4 amps. C.T. 6.3 v. 2 amps. C.T.

5 v. 3 amps. Fully shrouded, 75/-

F36. 250-0-250 v. 100 mA. 6.3 v. C.T.

6 amps. 5 v. 3 amps. Fully shrouded

30/9.

FS150. 350-0-350 v. 150 mA. 6.3 v.

2 amps. C.T. 6.3 v. 2 amps. C.T.

5 v. 3 amps. Fully shrouded, 34/9.

F30X. 300-0-300 v. 80 mA. 6.3 v.

7 amps., 5 v. 2 amps. Framed, 31/9.

E.H.T. TRANSFORMERS. Prices

on application.

The above have inputs of 200-250 v.

C.W.O. (ADD 1/3 in £ for carriage.)

H. ASHWORTH

676, Great Horton Road, Bradford,
Yorks. Tel.: Bradford 71916.

FIRST-CLASS TELEVISION and RADIO COURSES . . .

GET A CERTIFICATE!

After brief, intensely interesting study—undertaken at home in your spare time—YOU can secure your professional qualification or learn Servicing and Theory. Let us show you how!

FREE GUIDE

The New Free Guide contains 132 pages of information of the greatest importance to those seeking such success compelling qualifications as A.M.Brit.I.R.E., City and Guilds Final Radio, P.M.G. Radio Amateurs' Exams., Gen. Cert. of Educ., London B.Sc. (Eng.), A. M. I. P. E., A.M.I.Mech.E., Draughtsmanship (all branches), etc., together with particulars of our remarkable Guarantee of SUCCESS OR NO FEE

Write now for your copy of this invaluable publication. It may well prove to be the turning point in your career.

FOUNDED 1885—OVER

150,000 SUCCESSSES

NATIONAL INSTITUTE OF
ENGINEERING
(Dept. 462), 148, HOLBORN,
LONDON, E.C.1.

TELEVISION PICK-UPS AND REFLECTIONS

UNDERNEATH THE DIPOLE



By Icons

THE broadening front of television has reached to the north, and it will not be long before it arrives in Scotland. The vast new audiences, with tastes dissimilar to those of southern viewers, make the matter of alternative and/or Regional programmes of vital importance. The fact of the matter is that British viewers do not get full value out of even one programme channel—since certain of the items are repeated.

REPEAT PERFORMANCES

THE principal justifications for repeat performances are the saving in costs and the second opportunity given to viewers who missed the first presentation. I realise that the production costs of many plays and reviews are great, involving as they do two and sometimes three weeks of rehearsal with expensive artistes. If costs are the main factor, it is a pity that second thoughts cannot be applied to the possibilities of permitting a limited amount of sponsored programmes. With one or two evenings a week given over to outside interests, the BBC would be admitting a competitive element to TV entertainment, quite apart from deriving the revenue from the sub-letting of their stations. The different tastes of the various regions will speed up the demand for some kind of alternative programmes.

The television plays department have from time to time suffered lapses in submitting to their audiences plays of limited appeal, more suitable for a Sunday night theatre club, or other such backroom haunts of the pseudo-intelligentsia, than for the family entertainment of millions. The sooner the BBC drops its "quasi British Council" element, the better. There are plenty of big advertising firms only too ready to provide the necessary astringent in the form of first class all-star musical entertainment of "The Big Show" calibre, with a minimum of prescribed advertising matter superimposed. During the past two weeks I have mentioned these facts to upwards of 50 viewers in the London and Birmingham areas and have had not one dissentient with my opinions, which only goes to show just how out of touch with the viewing public the Beveridge Committee was!

TV POISON

WITHOUT claiming that my own limited research carries the weight of Dr. Gallup, I discovered that not one of the 50 people I questioned in the London and Birmingham regions had communicated their likes and dislikes to the BBC Listener Research Department. I am therefore prepared to find that the vitriolic opinions expressed by some of them may not coincide with the revelations of Listener Research. The plays of T. S. Eliot, Bernard Shaw and Christopher Fry may have their following, but not amongst my fifty! "What we want is a really good laugh," said most of them, "but we don't always like the London comics." The further north one gets, the more regional is the appeal of comedians—with certain celebrated exceptions. I think, for instance, that everybody would have liked to have taken part in the eighty-second birthday celebrations of George Robey at the Empire,

Sheffield, recently, when he cut a large birthday cake on the stage surrounded by an array of other "top-of-the-bill" favourites. The enthusiasm of the audience and the brilliance of the evening would have been fine material for television, much more to the taste of Midland audiences than some of this high-brow stuff. The Music Hall is part of the British heritage, though the introduction of PA systems and microphones has reduced the stagecraft requirements of artistes of the younger school to microscopic proportions. George Robey still disdains to use the microphone and yet is able to make himself heard quite easily at the back of the gallery. Many variety top-liners of to-day, imported from radio programmes, eschew make-up or special wardrobe and cling to the mike like the ivy to the garden wall! These comics could be left to return to their true metier—sound radio. But viewers will always be pleased to see Albert Modley, Terry-Thomas, Frank Randle and Norman Evans, in addition to such London favourites as the Crazy Gang, Leslie Henson and Flanagan and (if possible) Allen.

The usual BBC answer to the suggestion of some of these names is that contractual arrangements prohibit them being televised. I can't help thinking, however, that

PROFESSOR BOFFIN

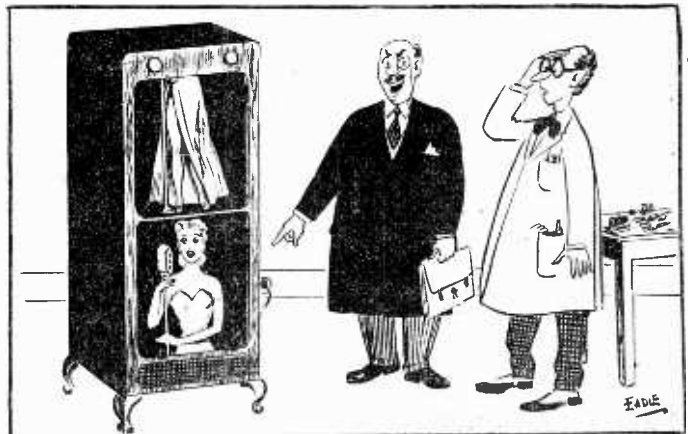

"I bow to your superior technical know-how, Boffin, but it does seem to me that this half should be at the top!"

if there was a competitive television service, a way would be found of putting every worthwhile star on to this medium.

DICTION AND DIALECT

THE advance of television into the Provinces will also necessitate greater attention being paid to the diction and dialect of artistes. In this respect, the worst offenders are the artistes in some of the plays, whose manner of speaking would not be tolerated in many provincial repertory companies. On the other hand, too great an adherence to dialect causes confusion to listeners. "The Little Foxes," a play concerning a small town in the southern states of America, may have been a good film and a good play on the stage, but its appeal on the television screen must have been limited. Not everyone can understand the southern American dialect any more than they can the broadest Lancashire, Cockney or Glasgow dialects, for that matter. However good the play may be, it is of vital importance that the customers can hear and understand every word! Whilst there are no alternative television programmes and the potential audience is now so immense, a criterion for play selection should be a choice of material which has universal appeal. Specialised audiences can be catered for later when there is a television "Third Programme."

ALTERNATIVE TRANSMISSIONS

WHEN discussing alternative programmes with viewers who are able to pick up either the London or

Birmingham transmissions, I was repeatedly asked about the possibility of sending a "Repeat" out on, say, the Birmingham frequency, while the London frequency was being used for new material or vice versa. There are technical problems in such a proposition affecting receiver design, but these are not very complex. A greater difficulty possibly arises in the matter of aerial arrays, particularly when the receiver is on the

fringe of both transmissions. It might require the fitting of a rotatable aerial or, alternatively, the erection of separate aeriels for each frequency. It must be remembered that one of the difficulties which have to be overcome by American set designers is the ability to tune in a large number of stations over quite a wide wave-band. It is accomplished, but not without certain losses apparent in the less expensive receivers.

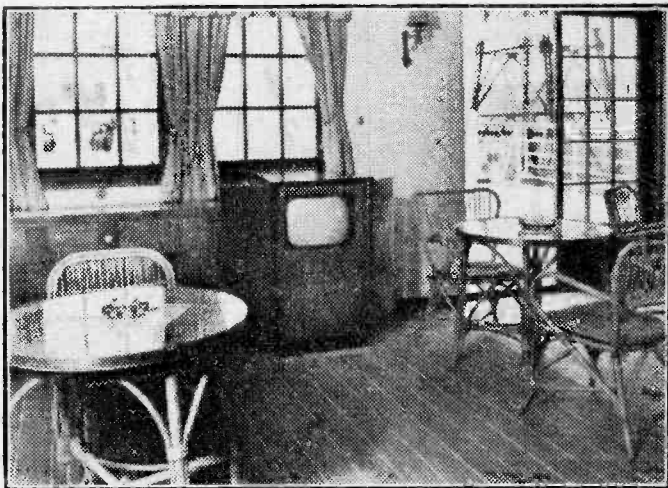

The two Swedish Lloyd ships have been making regular trips between Gothenburg and London during the summer months, remaining in Millwall Dock from Mondays to Saturdays, while many passengers used the ships as a "floating hotel" for their stay in London. A television set was installed by E. K. Cole Ltd. on each ship so that passengers could have the advantage of television in addition to other comforts during their stay in London.

Ferroxcube Core Material

FERROXCUBE, a new non-metallic, high permeability and low-loss magnetic core material, is to-day finding numerous important applications in the television industry. Many of these were shown on the Mullard stand at the National Radio Exhibition. They include line output transformers, deflection coils, and linearity and picture width controls.

The use of Ferroxcube in these components leads to improved efficiency, marked reductions in size and an appreciable saving in steel.

This new magnetic core material, which has the same structure as a cup and saucer, is made from the same raw materials as ordinary household paint.

A scientist would describe this new material as a "very high permeability, low-loss magnetic ferrite having a cubic lattice."

Ferroxcube is manufactured in this country by Mullard, one of its main constituents being iron oxide or common rust and, unlike other core materials used in the electronics industry, Ferroxcube is non-metallic. In appearance it is rather like a piece of black pottery. Yet it possesses remarkable magnetic properties which make possible notable improvements in the design and efficiency of numerous components used in television receivers. For example, used in the form of U-shaped

cores in line output transformers, it enables more compact and efficient assemblies to be produced.

Ferroxcube in its raw state can be pressed to almost any desired shape much in the same way as pottery. It can also be extruded into rods and tubes after the fashion of macaroni.

It is in the extruded form that Ferroxcube is used in linearity and picture width controls. In this particular application, Ferroxcube makes possible much smoother picture control from a small, compact and easily assembled unit.

The use of Ferroxcube for the U cores in line output transformers has numerous advantages over cores of the laminated type. The efficiency of the material at frequencies above 10 kc/s is greatly superior. Moreover, Ferroxcube, being of solid form, provides a more compact and easily assembled component.

A particular advantage resulting from the improved efficiency of line output transformers is that television designers are able to use smaller valves.

Ferroxcube core material in ring form can be conveniently used as the magnetic circuits round the deflection coils. In this application the Ferroxcube ring, having a very high permeability, provides excellent screening, thus reducing the possibility of leakage flux coupling with other components in the receiver.

Come to **SMITH'S** of **EDGWARE ROAD**,
the friendly shop, for all radio components

We stock everything the constructor needs—our 25 years' experience of handling radio parts and accessories enables us to select the best of the regular lines and the more useful items from the surplus markets in :—

Loudspeakers and Phones	Valves and CR Tubes
Transformers and Chokes	Cabinets and Cases
Meters & Test Equipment	Capacitors and Resistors
Pickups and Turntables	Coils and Formers
Switches and Dials	Plugs and Sockets
Metalwork and Bakelite	Aerials and Insulators
Books and Tools	Motors and Generators
Valveholders and Cans	Wires and Cables
Metal Rectifiers	Panel Lights and Fuses
Sleeving, Nuts and Bolts,	Recorders and Parts
Tags, Clips, Grommets and	
all other bits and pieces.	

NOTHING TOO LARGE—

NOTHING TOO SMALL

Everything you need under one roof—including all the parts specified for the "Viewmaster," "E.E." and "Easybuilt" Home-Constructor Televisors, both London and Birmingham models. (No catalogue available.)

H. L. SMITH & CO. LTD.

287/9 Edgware Road, London, W.2

Telephone: Paddington 5891

Hours 9 till 6 (Thursday, 1 o'clock)

Near Edgware Road Stations, Metropolitan and Bakerloo

The *Bennett* College
FOUNDED 1900

THE CORRESPONDENCE COLLEGE THAT
PUTS YOU IN A CLASS AHEAD.

POSTAL TUITION

paves the way to success
in the whole field of ★

RADIO & TELEVISION TECHNOLOGY

Subjects taught are :—

AVIATION WIRELESS	RADIO SERVICE ENG.
ELECTRICAL	RADIO SHORT WAVE
ENGINEERING	TELEVISION
ELECTRICAL	WIRELESS TELEGRAPHY
DRAUGHTSMANSHIP	TELECOMMUNICATIONS

Special Courses for: P.M.G. CERTIFICATE, AIR MIN. EXAM. CITY & GUILDS, RADIO TRADES EXAM. BOARD

★ Each student of the College is provided with tuition until he has passed the examination for which he has enrolled.

To Dept. 55.

THE BENNETT COLLEGE Ltd., SHEFFIELD

THE MODERN BOOK CO.

The De Luxe Home-Built Telesvisor and Radiogram, by W. I. Flack, 6/6, postage 5d.
Television Interference, by "Amateur Radio," 2/-, postage 2d.
Television Receiving Equipment, by W. T. Cocking, 3rd edition, 18/-, postage 9d.
Reference Data for Radio Engineers, compiled by W. L. McPherson, 7/-, postage 6d.
The Radio Amateur's Handbook, by The American Radio Relay League, 25th edition, 22/6, postage 1/-.
The Royal Signals Handbook of Line Communication, vol. 1, 20/-, postage 1/-.
Practical Wireless Encyclopedia, by F. J. Camm, 12th revised edition, 21/-, postage 9d.
Amplifiers (Audio Handbook No. 1), by N. H. Crowhurst, 3/6, postage 3d.
R.S.G.B. Amateur Radio Call Book, Autumn 1951, 3/6, postage 3d.
Radio Valve Data, by "Wireless World," 2nd edition, 3/6, postage 3d.
A Comprehensive Radio Valve Guide, by W. J. May, 5/-, postage 4d.
The Williamson Amplifier, by D. T. N. Williamson, 3/6, postage 3d.
Television Servicing, by S. Heller and I. Shulman, 51/-, postage 9d.
Cathode Ray Tube Traces, by H. Moss, 10/6, postage 6d.
We have the finest selection of British and American Radio books in the Country. Complete list on application.

19-23, PRAED STREET
(Dept. T.11),
LONDON, W.2

PADdington 4185.

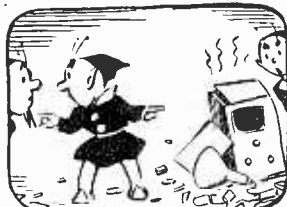

The "Fluxite Quins" at Work

"If you don't fetch our tin of FLUXITE

There'll be no television to-night!

The state it's in,

Is a mortal sin.

That's the last time we look at a fight."

See that **FLUXITE** is always by you—in the house—garage—workshop—wherever speedy soldering is needed. Used for over 40 years in Government works and by leading engineers and manufacturers. Of all ironmongers—in tins, from 1/- upwards.

The **FLUXITE GUN** puts **FLUXITE** where you want it by a simple pressure. Price 2/6, or filled 3/6.

FLUXITE

SIMPLIFIES ALL SOLDERING

Write for Book on the Art of "SOFT" Soldering and for Leaflets on CASE-HARDENING STEEL and TEMPERING TOOLS with **FLUXITE**. Price 1d. each.

FLUXITE Ltd., Dept. P.T.
Bermondsey Street, London, S.E.1

HOLME MOSS CONVERSION

Type AC/4 Converter unit for use with Sutton Coldfield receivers. Optimum picture detail and sound reception without retuning or alterations. Incorporates power supply unit, R.F. stage and the highly successful double mixer stage ensuring freedom from noise and correct reception of the new single side band transmitters.

Delivery at present ex-stock. Price complete with 5 valves, etc., 15 gns. On approval 7 days C.O.D. if desired or by arrangement through your own Dealer. Holme Moss models of the type AC/3 neutralized triode Pre-Amplifier are also available ex-stock. A well designed and proved unit giving the best possible results for 'Fringe' viewers. Our confidence in the unit is revealed by our 7 days approval offer. C.O.D. if desired or by arrangement through your Dealer. Illustrated leaflets and details, etc., available on request.

SPENCER WEST
Quay Works, Gt. Yarmouth

ALPHA OFFERS.

VALVES BRAND NEW AND BOXED

1T4	0/-	251GGT	0/-	6Q7	11/8
1B1	0/-	VR157	7/-	25A8G	9/-
1B5	9/-	CV9	4/-	NT40	11/8
1B5	9/-	QQ7	7/6	GJ5	5/6
1B4	10/6	6N7	10/6	6B8	7/6
0Z1	8/9	68G7	7/-	DDL4	4/8
0Z1M	9/-	MH14	6/9	8D2	4/9
0Z49	10/6	6AG7	7/9	12A9	7/9
0U4G	9/-	68Q7	9/-	6F6	9/-
6VGGT	9/-	YU39	9/-	FW4500	9/-
6VGG	9/-	42	9/8	6AM6	11/8
68N7	11/8	6AT5	9/6	KT8C	11/8
807	11/8	6L6	11/8	KT8B	11/8
88K7	7/-	41	7/-	7	7/-
8P56	7/-	EK92	7/-	6H6	4/-
AC6PEN	7/-	VU120A	4/-	VR18	4/-
68H7	7/-	955	5/-	EF30	9/-
PEN220A	4/-	VR31	7/6	Y65	9/-
835	9/-	78	9/-	IC5	9/8
6V8GT	9/-	3Q5GT	8/8	6I90	9/-
6G5	8/6	6C6	8/8	6J7	7/6
128K7	8/6	M8/PEN	8/8	CV6	2/-
KT241	7/-	7193	2/-	8P41	4/-
E1148	2/-	VR116	4/-	VF111	5/-
8P61	4/-	2X2	5/8	80	9/-
SP61	4/-	VR150/50	9/-	EB34	3/6
6U6G	7/6	EP8	7/6	EF39	7/8
EA59	2/8	CV72	4/9	6K7GT	6/8
128C3	7/9	12K8	9/-	6L4	6/-
6K7G	6/8	PM2A	5/6	6R8	13/-

MOULDED MICA CONDENSERS

.001, .002, .0025, .0035, 5/8 doz.
.01, .001, .003, .003, .005, 7/- doz.

VOLUME CONTROLS

1, 4, 1, 2 Meg., 100 K. Ohms, with switch, 4/3 each.
25 K., 50 K., 1, 1 and 1 Meg. Double Pole Switch, 5/- each.
2 K., 1 K., 3 K., 5 K., 25 K., less switch, 1/6 each.

SEE OUR OTHER ADVERT.
MAIL ORDERS ONLY. C.W.O.—C.O.D.
DELIVERY BY RETURN. POSTAGE EXTRA.

ALPHA RADIO SUPPLY CO.,
5/8 Vices Chambers, Victoria Square, Leeds, 1.



Now in our eleventh year and Still—

NO B.N.R.S. STUDENT HAS EVER FAILED

To pass his examination(s) after completing our appropriate study course! All courses are by post and our syllabus includes C. & G., Brit.I.R.E. & P.M.G. examinations, Radio, Radar, Television, Maths. and Physics.

Six months' trial period without obligation to continue.

Please mention this advt. and send for free booklet to—

STUDIES DIRECTOR
BRITISH NATIONAL RADIO SCHOOL
66, ADDISCOMBE ROAD, CROYDON
Phone: Addiscombe 3341

DUKE & CO.

RADIO CONTROL UNIT, 12/6. Including speaker, 3in. tweeter, 25 resistances, including wirewound, L.F. trans. Various condensers, 2 instrument type fuses, 8 international octals ceramic, 3 Accura ceramic v.holders, 7 v.controls, Relay with multi-contacts, 2 Co-ax connectors, Wire and all the usual parts, etc. Clean chassis and cabinet of pleasing appearance. Ideal amplifier or receiver, etc. Post 2/- extra.

SHORTWAVE SUPERHET, 15/8. No. 18 set, receiver. FREE INSTRUCTIONS for conversion to All-wave and Circuit Diagram included. Note: set with a little alteration makes first-class portable or car radio. I.F.s 465. Change over to P. Coils for medium-wave. Less valves. There are only a very limited number of these sets and our previous supplies were quickly sold out.

TYPE 25 1186 SUPERHET RECEIVER.—Limited number of these bargains. Note: Price 12/6 each, with free drawings. These convert easily to A.C. Universal or Battery All-Wave receivers, 465 I.F.s, 4 tuning conds., 28 fixed conds., 32 resist., trans. switches, v.control v.holders, and all the usual parts less valves, post 1/6.

LATEST MIDGET RADIO.—In plastic cabinet, walnut or ivory, 1-valve T.R.F. Universal or A/C for only £5 12/6. Assembled 35/- extra. New and improved circuits. An amateur can build this set with practically no knowledge. The ONLY set now available at this price. Post & packing 2/8.

NICKEL-CHROME WIRE.—50yd. spool of .014 wire for only 4/6, or 25yds. of .022 for same price. These prices are a fraction of today's prices (if you can buy it).
TELEVISION LENS. Magnifier, enlarger, half normal price, best manufacture, 8in., 9in. and 10in., 55/-, 10in. and 12in., 75/-.
AERIALS, 300ft. on winch, ex-W.D., new, 2/9. Also 12ft. in 3 sections 4ft. each. Tubular, copper-plated steel. Only 7/-, Carr. 2/- extra.
Money back guarantee. Cash with order, please, or C.O.D. Stamps ONLY for Lists.
Mail Orders: 621, Romford Road, Manor Park, London, E.12. GRA. 6877.
Personal shoppers: 219, Hford Lane, Hford. HLF. 0295.

GRAM MOTORS & PICK-UPS for MICROGROOVE RECORDS

B.S.R. MU-10 motors for 33 & 78 r.p.m. Speed change by reversing drive pulley. 10in. turntable. 100-250v. **£3.15s.**

MU-14 de luxe model with ROTACAM instant speed change for 33 & 78 r.p.m. **£7. 3. 4.**

ACOS GP-20 pickups, standard **£3.11s**
GP-19 LP microgroove head only **£3.4**

Frith RADIOCRAFT Ltd. PHONE 58927
60-71 CHURCH GATE, LEICESTER

"ADCOLA" SOLDERING INSTRUMENTS

Reg. Trade Mark

Regd. Design No. 860302
(British, U.S. and Foreign Patents.)
For Wireless and Television Assembly

The advanced design of the Adcola Instruments meets the modern requirements of Television, Telecommunication and Radar Engineers.

SUPPLIES FOR ALL VOLT RANGES FROM 617v. to 230/250v.

3/16in. dia. Bit. Standard Model	22/6
3/16in. dia. Bit. Standard Model	25/6
3/16in. dia. Detachable Bit. Model	30/-

Sole Manufacturers
ADCOLA PRODUCTS LIMITED
GENERAL OFFICES AND WORKS
Cranmer Court, Clapham High Street, London, S.W.4.
(N.A.Caulay 4272)

THE NEW 1355 CONVERSION The now famous self-contained TV receiver. Data for all Five TV channels, 3/- per copy.

MAINS TRANSFORMER, as specified, 52/6, metal rectifiers as specified, 4/6 each.

RECEIVER TYPE 1225. A UHF receiver, containing five EF50's, two EF39's, and one EB34; Chock-full of useful components, these are pre-tuned to four predetermined frequencies, and may easily be slightly modified for normal UHF working. 39/6 (1/6 post).

POWER UNIT 532. Containing 5Z4 rectifier, VU120 EHT rectifier (5,000 v., with 2 v. indirectly heated heater) two 80 v. transformers, one smoothing choke, high resistance relay, .1, 23 kV. condenser, two other condensers, etc., etc., complete with our 50 cps conversion data for EHT or H.T. 17/6 (2/3 carriage).

RADIO EXCHANGE CO.,
9, CAULDWELL STREET, BEDFORD. Phone: 5568.

HR

QUALITY TELEVISION COMPONENTS
SCANNING COILS P.M. FOCUS UNITS
6/10 kv. R.F., E.H.T. UNITS
E.H.T. and OUTPUT TRANSFORMERS
LINE FLY-BACK E.H.T. UNITS

"TELEVISION CIRCUITS"
Third Edition, 64 pages, 2/6 post free

HAYNES RADIO Ltd., Queensway, Enfield, Middlesex.

CORRESPONDENCE

The Editor does not necessarily agree with the opinions expressed by his correspondents. All letters must be accompanied by the name and address of the sender (not necessarily for publication).

IMPROVING A COMMERCIAL RECEIVER

SIR,—I was very interested in your July article by Mr. Morley regarding the improvement of a commercial receiver.

My set, purchased in April, although fitted with one pre-amplifier stage had never produced any worth-while pictures until recently.

I found that there was not sufficient margin of horizontal hold to enable a good picture to be maintained. If I adjusted to the right for a tight hold, the picture broke up at the top, and if I moved to the left, the entire outline scattered.

It happened immediately after spring-cleaning. We were bringing the furniture back into the sitting-room and had connected the TV for an evening show, but had not got everything tidy.

I noticed as I handled the coaxial and radio aerials that my picture varied in strength, and to my surprise upon gripping the two aerials in my hand, my picture brightened up considerably and the horizontal drew up to form a perfect hold.

I played about with this for a considerable while and found that with the radio turned on and warmed up that the margin of horizontal hold increased yet more.

The technical aspects of this are beyond me, but there may be others who will find this of interest and possibly help; especially if in the fringe area as I am.

I now operate both sound radio and TV aerial leads lashed together and covered with duralumin foil for about 4ft. inside my sitting-room and, since doing so, have had some very enjoyable viewing.

Before writing this note to-night, I broke the leads apart once again and reverted back to results as previously, which seems to indicate that the signal can be augmented as I have outlined above.

It is now my intention to string up another aerial and explore the possibilities further, along the lines already mentioned.

My grateful thanks for your excellent paper and the help it has afforded me.—J. F. CHAPMAN (Histon, Cambs).

HOME-CONSTRUCTOR EFFORTS

SIR,—As a regular reader of PRACTICAL TELEVISION I thought you might be interested in the accompanying illustrations of a combined television (12in. tube) and radiogram which I have constructed throughout, including the cabinet, which is of my own design.

The overall size is only 1ft. 10in. wide, 3ft. 7in. high, and 1ft. 6in. deep; construction of deal and plywood painted cream enamel to match door, skirting, etc., in the room.

The radio section and the television chassis can be drawn out separately, for repairs, in a few moments.

The front panel is in plywood polished black. The cabinet is mounted on concealed ball-bearing castors.

I thought it might give some ideas to readers who may not realise that a really first-class combined television and radio-gramophone can be built into such a comparatively small cabinet.—JOHN B. TURNBULL (E. Croydon).

"THE CASCODE AMPLIFIER"

SIR,—I note that Mr. G. Bulland in your August issue takes exception to my statement concerning a normal R.F. stage. I was referring, of course, to the choice of circuit arrangements for television pre-amplifiers and did not include the specialised applications of grounded grid stages. Fortunately, I do not need to deal with the matter in detail, for Mr. D. W. Thomasson, in his article "The Noise Factor" (PRACTICAL TELEVISION, July, 1951), deals ably with the grounded grid stage, and Mr. Bulland has respectfully referred to this article. I would like, however, to emphasise the point that the low input impedance of the grounded grid stage is not an advantage. It, unfortunately, results from the method of connection, and is not sought after. Also, even when a very broadband operation is required this low input impedance is not very useful for, due to transit time effects, the benefits of a noiseless damping resistance are not fully realisable at V.H.F. Incidentally, the circuit arrangement is not so stable as Mr. Bulland claims. It will oscillate readily unless precautions are taken, or if an incorrect type of valve is employed. In order to re-affirm my original statement concerning the superiority of a pentode stage compared with a grounded grid one for a television pre-amplifier, it is necessary to point out a reason for this, one which is ordinarily overlooked.

The gain secured from a grounded grid stage is low, thus a second stage noise cannot be disregarded. On

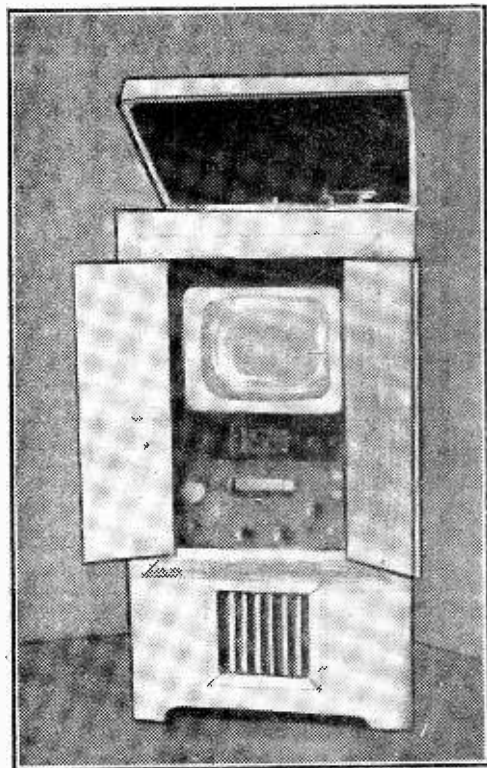

The combined television receiver and radiogram built by Mr. John B. Turnbull.

the other hand, a pentode will provide a good gain figure and thus overall noise will be lower. I hasten to add that this applies in particular to a television pre-amplifier, and is an argument not necessarily correct for the general case. It can be readily confirmed, however, by the amateur experimenter who is using a television receiver at long distances from the transmitter.

Finally, were I asked to express an opinion, based on personal reception experience, of the relative merits of various circuit arrangements for television pre-amplifiers intended for long-range reception, these would be in the following order:

(1) Neutralised triode followed by a grounded grid or conventional pentode stage.

(2) Single pentode stage (preferably of the low-noise type).

The first alternative of (1) is superior to any other arrangement. Any of these three circuits can be used as balanced arrangements but, of course, they become more complicated.—S. WEST (Gt. Yarmouth).

R1124C—DETAILS WANTED

SIR,—Could any reader give me information regarding the R1124C receiver?

Perhaps one knows where I could get circuit and power supply details? Any hints on converting this set for television, or anything interesting, would be welcome.—G. L. HARRIS (Hounslow).

7BP7—DETAILS WANTED

SIR,—I was recently presented with a cathode-ray tube, type 7BP7, and whilst I doubt whether it is of use for TV purposes, I wonder if readers can give me any information concerning it.

The screen appears to have rather a long persistence but until I see it in operation it is not easy to prove this point.

If you could possibly help me over the following points I should be very pleased:

1. Supply voltages.
2. Pin connections.
3. Whether tube suitable for TV.
4. Whether any commercial deflecting coils are available to suit this tube.—F. E. PROFAZE (Southgate).

STANDARD MAINTAINED

SIR,—I well remember how eagerly our little group of amateurs looked forward to the first issue of PRACTICAL TELEVISION, how good we found it and how, in the cynical manner of long-service amateurs, we shook our heads and said: "They'll never keep it up" (meaning, of course, the excellent standard of the first issue). Well, we are now into Volume 2 and we all agree that the standard has even been improved upon. Particularly do I like your new feature of reviewing commercial sets. Now I want to bind the first volume, both for convenience in reference and to stop the pernicious habit of borrowing and forgetting to return odd copies which frequently takes place among "hams."

Do you issue indexes?

Again, congratulations and thanks.—Mr. R. A. ILETT (Cleethorpes).

[Indexes for Vol. 1 cost 1s. 1d., by post.—ED.]

GERMAN TV

SIR,—You may be interested to hear that the Nordwestdeutscher Rundfunk are now operating an experimental transmitter at Hamburg and by the

spring of 1952, hope to have in operation a 10 kW. transmitter in Hamburg, a further 10 kW. transmitter in Langenberg and later in 1952, a 1 kW. transmitter in the Hanover area. I understand that at the moment some 18 German firms are in the process of building television receivers, which it is anticipated will be on the market to the general public in March, 1952, at a price ranging between 1,000 and 1,500 DMs. (11.78 DM. to the £ sterling). screening will be approximately 9 x 12 and so far there have been no experiments in colour television. The experimental programme from Hamburg is transmitted on Monday, Wednesday and Friday of each week from 20.00 until 22.00 hours.

The details of the Hamburg experimental transmitter are as follows:

Sound, 194.25 Mc/s per second. Power, 300 watts.

Vision, 189.75 Mc/s per second. Power, 1 kW.

Lineage, 625 interlaced.

Twenty-five frames per second.

Negative modulation.

Horizontally polarised.—H. L. PARRY (Hanover).

INTERFERENCE

SIR,—May I suggest that it would have been as well if you had made it clear in your August issue Editorial that although it is not an offence to cause interference by means of any wireless (unless the interference is caused deliberately) there is, in the Postmaster-General's licences issued in respect of receiving apparatus, a condition that such apparatus shall not be used in such a manner as to cause interference with the working of other apparatus. Most manufacturers undertake to modify apparatus which is causing trouble and most users arrange for the modifications to be made as soon as the matter is brought to their notice. Where there is no bad feeling between complainant and owner of the interfering set, they can usually arrange to settle matters to their mutual satisfaction.—SIDNEY R. CAMPION (Principal Information Officer, Press and Broadcast Division, G.P.O.).

THE RADIO INTERFERENCE SERVICE

(continued from page 267.)

visible and it transpired that the loudspeaker was embedded in a wall that had just been re-papered. It was also learnt that when a certain handbell was rung, the ringing could be heard in radio sets nearby. The local electricity distribution is overhead, and the radio staff found that crackling noises could be heard in a portable receiver in the vicinity of the power line. This suggested a defect in the line or in a consumer's installation connected to it. While tracing along the line, the I.O. heard barking on his portable receiver and traced it to a shed at the side of a house, where the dog was barking furiously. Investigations in the immediate vicinity led to an electric pump-motor, the earth wire of which had broken away from the frame of the motor and lay loosely across it. Evidently the loose contact functioned as a microphone and sound occurring in the vicinity modulated the radio-frequency currents induced in the overhead wiring by the local broadcast transmission. Subsequent re-radiation could account for the usual type of interference. The trouble disappeared when the earth wire was properly connected.

BARGAINS—Condensers: 32/32 mfd. 350v. tub. card, 2/6; 8/500, 2/6; 50/50, 2/6; 16.8-4/500, 7/6; 16-24/350, 5/-. Variables-twin, .0005 5/-. single 3/6, twin with 2-speed reduction 6/6, 4 gang 7/6, 75pf D.E. 2/-; twin 4/-, 3 gang 25pf 3/6, single 1/3, 50pf 1/2. Muirhead Drives (black), 7/6. Epic-cyclic drives, 1/3. Spindle Couplers, brass, concertina or insulated 9d.; Eddystone type, 1/3. Mine Detector amp. with 3 x 1T4 valves, 2/6; Chassis, only 3/6. Potentiometers, carbon, 0/9, with SP sw. 3/6, wire-wound 2/6. Mains Droppers, 2A or 3A, 5/-; Linecord, 3A 3-way, 1/- yd. Rotary Toggles, 1/-. Williamson Amplifier Manual, 2/6. Pre-amps, type, 6048 17/6, less valves 10/6. Coilformers Pax, slugged, 2in. x 1in., 4 for 1/3. Post free over 12/6. S.A.E. for 300-item List. W. A. BENSON, 308, Rathbone Rd., Liverpool, 13.

PRACTICAL TELEVISION—Latest Broadcast/TV Set, complete set of formers and cans. L.T. L18. £1; RF coils wound chassis made to order, condenser kits supplied. Trade supplied. BEL, Marlborough Yard, London Archway, N.19. (ARC 5078).

PREMIER MAGNETIC Time Base, 9in. tube, fly-back E.H.T., £16; 1355 Vision Receiver, built-in power pack, £3; Sound Receiver, Speaker and T.B. Power Pack, £6; 1355, original condition, 30/-. All working. C. W. NASH, 64, Park Avenue, Orpington, Kent.

THOUSANDS enjoyed them this summer. Did you? Build your own "Personal Portables" or even make "A Portable Television" and beat the Budget. "Personal Portables" 2/8, "A Portable Television" 3/2, post paid, from BRADBOOKS, Sen-nen, Penzance, Cornwall.

ELECTRICAL TEST METERS, all makes single or multi-range repaired and standardised. THE ELECTRICAL INSTRUMENT REPAIR SERVICE, 329, Kilburn Lane, London, W.9. (Tel.: Lad. 4168.)

VIEWMASTER and EE Televisors. All parts in stock. Model on show. H.G. RADIO, 1350, Stratford Rd., Birmingham, 28. (SPR 2369.)

TELEVISION AERIAL COMPONENTS, Alloy Tube drawn in A.W.10.G.; Masi-head Brackets alloy and wood masts, Chimney Brackets, Corner Plates and Lashing Cable, J. Strainer Bolts, U Bolts, etc. WALTER CRANE, Electrical Engineers, Wakefield. (Telephone: 2172.)

MAKE THESE RECEIVERS. Concise books of instructions, 1/6 ea., for TRF, 2SW, £5/10/-; MSS S'het., £6; LMS S'het., £6/5/-, complete with cabinet and valves. Thousands of Components available: 1 x 350v. Tub, 2/9 doz.; Dial Drum, 24in., 6d.; Microphones, 1/6; ex-RAF 40.1 Trans., 6d.; etc. etc. 3d. stamp for latest list. SUSSEX ELECTRONICS LTD. (T), Princes St., Brighton.

CONDENSERS, brand new, 1/500v tubular, 4/6 doz., post 4d. S.A.E. list bargains. MELHUISE, 315, Ewell Rd., Tolworth, Surrey.

CRT TUBES—15in. Emiscope, £9; 10in. Emiscope, 30/-; 9in. Mullard, £2. Box No. 113, c/o PRACTICAL TELEVISION.

COMBINED T/V Broadcast Receiver. All parts, including coils and B.V.A. Valves supplied. JARVIS, 12, Chatsworth Rd., Manchester, 21.

RATES: 3/- per line or part thereof, average five words to line, minimum 2 lines, Box No. 64, extra. Advertisements must be prepaid and addressed to Advertisement Manager, "Practical Television," Tower House, Southampton St., Strand, London, W.C.2.

"VIEWMASTER" Valves, as specified, all guaranteed brand new and boxed, comprising 5 EF50, 1 6P25, 1 EL33, 1 EB33, 1 EB91, 2 6K25, 1 6P28, set of 12, £9/9/6, New boxed EF50, 7/6; ECH35, X61M, CCH35, EF91, 6F12, 10/6; 6AL5, EB91, 6D2, 9/6; EF39, 6K76, 6K7GT, HVR2A, KT2, EF8, 9D2, 7/9. Miniature all-dry Battery types, 1S5, 1R5, 1F4, 3V4, 3S4, 8/9 each; all brand new and boxed. Ex-Govt. Telescopic Aerials, eight section, fully extended over 9ft., 5/6 each. P.M. Speakers, leading makes, 5in. and 6in., 12/6, 8in., 14/9. C.W.O. Post paid, 30/6. READERS RADIO, 24, Colberg Place, Stamford Hill, London, N.16.

RADIO SUPPLY CO., 15, Wellington St., Leeds.—Ex-Gov. E.H.T. Smoothing Condensers, 5mfd, 3.500v., 1/9; S.T.C. Rects., 680v, 30 m.a., H.W. 6/11; E.H.T. Valve Rectifiers (boxed), VU133 (4v.), 3/3, VU120A (2v.) 2/9; brand new Mains Transformers Primarys, 200-250v, 50 c/cs., 250-0-250v, 100 m.a., 6/3v., 6d., 5v., 3a, for R1355 conversion, 25/9; 300-0-300v., 70 m.a., 6.3v., 3a, 4v., 2a, ex-E.M.I. 10/11; 260-0-260v., 70 m.a., 6.3v., 2a, 5v., 2a, Midget, 12/11; P.M. Speakers (2-3 ohm speech coils), closed field types, 5in., 6in., 15/9, 10in., 25/9. All goods guaranteed. Full list 4d. C.W.O. or C.O.D. over £1. Postage, 1/3 extra under £2.

C.R. TUBE, 3in. MW14C, new, boxed, £10. GERRY, T.V. and Radio Specialist, 22, Birkbeck Rd., Sidcup.

VALVE BARGAINS, new and guaranteed. 1L4, 3Q4, 3A4, 6C4, 7/6; 6AK5, 12/6; CV139, 6J4, 15/-; 6J6, 20/-; 6AG5, 6AJ5, 8/6; Z77, 11/6; EF80, 17/6; ECL90, 18/6; 5U4, 10/-; EL32, 6/6; EA50, 3/-. Also a few EF36, 5P1, VR16, ATPT, FT11, VU111, VU133, 4/-, slightly soiled but guaranteed. Table Mikes with fully adjustable Stand and switch in base; no battery required; a real snip at 7/6, plus 1/6 post. (These are usually advertised at 12/6). Other items advertised last month still available. Money back if not satisfied. Please call at least 6d. p and p. on all orders. ELECTRAD RADIO, 69, High St., Belfast, N. I.

SERVICE SHEETS for hire. Reasonable terms S.A.E. for particulars to W. J. HERBERT, 118, Gelli Rd., Gelli Pentre, Rhondda, Glam.

 10 minutes is the time taken to change over
SUTTON COLDFIELD tuned T.V.'s to receive HOLME MOSS with our HM.2 Frequency Converter unit. Retail £8-0-0.

And for "long range" reception our T.V. Pre-Amplifiers are still "Pre-Eminent." Retail at £5-17-6 and £7-10-0.

Obtainable through your dealer or direct.

RAINBOW RADIO MFG. Co. Ltd.
Mincing Lane, Blackburn, Lancashire.

RADIO UNLIMITED, Elm Road, London, E.17 (KEY 4813). Guaranteed components. Speakers, 24in., 15 ohm, 13/6; 3in., 11/6; 3in., 14/6; 5in., 12/11; 8in., non-mag., 15/6; 10in., 31/-. V-controls, semi-midget, 50K, 4 and 2 meg., L/sw. L/spindle 2/9; std. size, 10K, 50K, 100K, 4, 1, 1 and 2 meg., W/sw. L/spindle, 4/-. Condensers, all 450v. 4ml, 1/6; 8mf, 2/9; 16, 2/9, 8 x 16, 4/3; 16 x 16, 4/6; 32 x 32, 6/6; 32 x 32, 350v, 5/9; 25/25 bias, 1/6, 50 x 50, 2/3. Valves, EF36, EF39, EB33, 8/6; EL32, 7/9; EF91, EB91, EF50, 10/- each; HVR2A, 6/6; SP61, 5/6; SP41, 5/-. All Holders, 6/6 doz.; BTG (amph), 9/- doz. Over 15,000 B.V.A. Valves in stock. Order c.o.d.

T.V. CABINETS !! We are pleased to announce that further orders can now be accepted for our Standard Console Cabinets (with full or half length doors) suitable for all popular kits. We also construct cabinets of all types to customer's own requirements. Send s.a.e. for full information to: D. CHURCH, ESQ., 14a, Harrow Rd., Wembley, Middx.

BERNARDS, Television, Radio and Amplifiers repairs, conversions, etc., commercial radios rebuilt; ex-Govt. equipment not accepted; despatch with full instructions for quotation by return post, 12 months guarantee on all work done. Note new address, 295, Munster Rd., Fulham, S.W.6.

SITUATIONS VACANT

EX RADIO and Radar Personnel, Civilian or ex-Service, urgently required for interesting work. West Middlesex area. Well-paid jobs await those accepted for preliminary training in central London. Three-quarters full Union rate paid during three months' training. Contracts offered suitable applicants. This is a genuine offer of employment by one of the largest electronic organisations. Write for particulars and application form. Box No. 114, c/o PRACTICAL TELEVISION.

TELEVISION and Radio Mechanic. Excellent opportunity in Service dept. of well known, old-established manufacturer. Good wages and conditions. Learners will be considered. Apply, Weybridge 4271.

EDUCATIONAL

TELEVISION—The Gothic Television School, devoted exclusively to training in Television, prepares students to Brit.I.R.E. and R.T.E.B. examination standards. Correspondence course prospectus from the Secretary, **GOTHIC TELEVISION SCHOOL**, 13, North Avenue, London, W.13.

TELEVISION Servicing and Theoretical (postal) Courses at extremely moderate fees are available from the Institute of Practical Radio Engineers, either for study or as reading matter only. Syllabus post free from the Secretary, I.P.R.E., 20, Fairfield Road, London, N.8.

FREE! Brochure giving details of Home Study Training in Radio, Television, and all branches of Electronics. Courses for the hobby enthusiast or for those aiming at the A.M.Brit.I.R.E., City and Guilds Telecommunications R.T.E.B., and other professional examinations. Train with the college operated by Britain's largest electronic organisation. Moderate fees. Write to E.M.I. INSTITUTES, Postal Division, Dept. P.T.28, 43, Grove Park Rd., London, W.4. (Chiswick 4417.) (Associated with H.M.V.)

TRADE TOPICS

Television Signal Generator

THE W.90 signal generator is a compact television signal source suitable for use in production test departments, development laboratories and service departments. With this instrument the engineer is independent of live transmissions for adjusting and testing television receivers and, in addition, has at his disposal a choice of test patterns of known characteristics which can be used at any time. The provision of a constant signal modulated with the correct synchronising and blanking pulses enables quantitative measurements to be made of the various stages of a receiver and the performance of different receivers may be readily compared with positive conclusions.

The R.F. generator provides a continuously variable signal over the television band of 40 Mc/s to 70 Mc/s with a high degree of frequency stability. The output is controlled by an attenuator of 20 db steps in conjunction with an R.F. control and calibrated meter, providing between 1 microvolt and 100 millivolts at a source impedance of 80 ohms. A higher output of approximately 500 mV is available for multi-distribution.

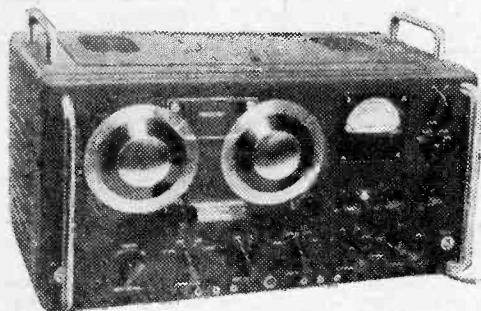

The new 'Waveforms' signal generator

Combined in the instrument is an independent R.F. oscillator with a frequency of 40 Mc/s to 70 Mc/s which can be internally modulated with an audio tone of 400 cycles or externally modulated from a radio receiver or pick-up, etc. The R.F. carrier may be obtained unmodulated. The following facilities are available:

1. R.F. unmodulated, for sound or vision R.F. measurements.
2. R.F. modulated at 400 cycles.
3. R.F. externally modulated.
4. R.F. modulated with video and sync pulses, or sync pulses only.

5. 1 and 4, or 2 and 4, or 3 and 4 may be obtained simultaneously providing a complete sound and vision source at independent respective levels:

The video modulation is in accordance with the BBC standards and includes horizontal and vertical blanking pulses and the correct synchronising pulses. The ratio of sync to modulation is carefully maintained and the half line frame pulses and the front and back porches of the line pulses are included.

Any of the eight line and frame patterns provided by

the instrument may be combined to produce a complex pattern. For example, patterns 3 and 8 together provide a crosshatch pattern suitable for observing "pin-cushion" and "barrel" distortion and the combined effect of non-linearity of line and frame.

The complete video waveform is available for V.F. checks and the complete sync waveform, line sync pulses and frame sync pulses are brought out separately. Line and frame blanking pulses can be brought out separately for use with flying spot scanners or monoscope tubes.—Price on application.—Waveforms, Ltd., 26, Oakleigh Road, New Southgate, London, N.11.

5-Channel Television Tuner

THE permeability tuned gang multi-station television tuner introduced by Plessey, permits the manufacture of a single television receiver model to cover all five BBC frequencies. It is the first unit tuner for the British stations to be made commercially available.

The unit comprises a tuned R.F. stage covering a frequency band of 40.0—70.0 Mc/s. and a mechanically ganged system of three coils—R.F. grid, R.F. anode and oscillator. The oscillator valve is not mounted on the unit. A calibrated scale facilitates tuning to any of the five BBC television transmitters within this range.

Good tracking is achieved by the employment of padding coils. In the case of the oscillator working below signal frequency, the auxiliary padding coils are placed in parallel with the R.F. circuits, while in the case of the oscillator working above signal frequency, the oscillator coil itself is shunted.

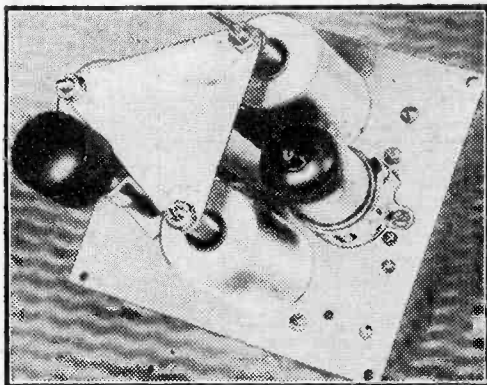

A 5-channel tuner by Plessey

The R.F. grid circuit padding coil is mounted outside the ganged R.F. coil, and serves simultaneously as an aerial coupling auto-transformer. It can be independently adjusted for an optimum performance by means of a threaded iron core.

High electrical stability is claimed for the unit, and this is attributed to the use of temperature compensated tuning condensers in the oscillator circuit.

Mechanical stability is attained by accurate machining of the tuning drive, and complete freedom of back-lash resulting from the use of several independent springs and floating tuning cores. These latter are of composite iron dust and aluminium composition, and can be pre-adjusted individually for tracking purposes.—Plessey Co., Ltd., Ilford, Essex.

YOUR Problems SOLVED

Whilst we are always pleased to assist readers with their technical difficulties, we regret that we are unable to supply diagrams or provide instructions for modifying surplus equipment. We cannot supply alternative details for constructional articles which appear in these pages. WE CANNOT UNDERTAKE TO ANSWER QUERIES OVER THE TELEPHONE. If a postal reply is required a stamped and addressed envelope must be enclosed.

WEAK INPUT

"I am getting good results with my Viewmaster, 25 miles from London, using a loft aerial. The set, however, gets hot after one hour's use, and the wax in the heater transformer begins to melt. The noise suppressor does not function. I have tried the set with it out of action, but without improvement. When a car passes the door sound is completely eliminated."—S. G. S. (Pitsea).

The fact that you are using a loft aerial means that you have a fairly weak signal input to the receiver and gain accordingly has to be well advanced. Under these conditions, interference is difficult to suppress and you will find that a good reflector aerial, well up in the open, with an attenuator if necessary to avoid overloading the input valve, would result in considerably weakened interference and a good picture.

The fact that the receiver is running very hot may be due to the fact that there is some overloading, though in this case we would have expected a reduced picture size, but still suggest that you have the total consumption of the receiver checked.

"GRAIN"

"I am using a 2-valve pre-amplifier, but the picture is marred by 'grain.' Is there a pre-amp on the market which embodies Mr. Rodwell's (your contributor) 'Cascade' circuit, and do you think it is superior to an R.F. pentode pre-amp?"—R. C. M. (Nr. Bridgend).

The grain is valve noise due to the fact that you are using so many stages and it is better, therefore, to use a more efficient aerial system and try and reduce the number of stages. Some experiment with the aerial is indicated in your locality, and, as you are in a valley, it is worth while trying the effect of tilting the aerial as the actual transmitted wave may come down into the valley at an angle. The only effect of the insulation on the aerial is to avoid corrosion, but your aerial may have been treated for your purpose although not covered.

HIDDEN RECEIVER

"Is it possible to construct a television receiver in such a way that the tube is separate from the rest of the set which can be hidden from view with only the tube visible?"—E. G. S. (Stockwell, S.W.9).

Unfortunately it is not possible to carry out the idea you mention in practice. The lead feeding the tube is very susceptible to hum and stray interference, and although it is possible to use a cathode follower to reduce some of this effect, the synchronising circuits feeding the scanning coil cannot be lengthened unduly and interaction will take place between frame and line. The only satisfactory way of carrying out your idea would be to have time bases and tube, together with cathode follower video stage. The change would mean two or more

video stages to make up for the loss in gain, and remote controls would definitely have to be fitted.

CAUSING INTERFERENCE

"I have a commercial television receiver which is causing interference to neighbouring sets. Can you tell me who is legally responsible for abatement of the nuisance, since the manufacturers inform me that they have only had three similar complaints with this particular model? They also told me that their latest model incorporates the necessary modification to overcome this fault."—D. M. (Tipton).

It is not an offence at present to cause interference with a television receiver. The neighbours can complain to the Post Office, and a G.P.O. engineer will probably call and suggest that you do something about it. There is no law, however, to compel you to do so, although it would be a neighbourly thing to try to effect an improvement.

When the law is changed, the user, not the manufacturer, will be responsible, just as with a noisy motor cycle it is the driver and not the manufacturer who is charged.

Why not suggest to the manufacturer that you bought the receiver in good faith, believing it would not cause interference and that you feel sure they will comply with this implied warranty?

PROJECTION AND DIRECT VISION

"Why does a projection television set cost more than the direct vision type?"—W. D. (Yorkshire).

If you have studied the articles we have published on projection television, you will see that the optical unit is quite complicated and, in addition, the components which have to be used with the special size tube are also expensive. The screen alone is a high-priced article and the silver surfaced mirror which is fixed inside the lid to throw the picture on to the back of the screen also adds to the price, whilst, as you have noticed, the E.H.T. unit to deliver the required 27 kV. is also an expensive item.

ALIGNING TELEVISION RECEIVER

"When aligning my home-built television set, the rectifier H.T. valve arced over and blew the house lighting fuse. I have replaced the valve, the mains transformer seems O.K., but I am not sure of the electrolytic capacitors, of which there are three: one reservoir, one dual smoothing for time bases and vision, one smoothing for sound chassis. Values are respectively, 32 μ F., 32-32 μ F. and 30 μ F.

"Can you inform me how I can tell when it is safe to make a running test after a rectifier valve failure? An ohmmeter test across the rectifier filament and chassis leaves an element of doubt as to whether I can safely switch on again."—S. E. M. (Leeds).

The easiest test is to disconnect the condensers and then check the resistance between the positive and negative lines—it should be zero. Leaving the meter connected, reconnect the electrolytics one at a time and there should be a fluctuation of the needle on connecting, which should then slowly fall back to zero, but if the needle rises to a resistance reading and stays there, it will indicate that the condenser is leaking and should not be included.

The time base amplifier should be connected to the coils and it is quite in order to disconnect the E.H.T. when testing out the set. If you did not connect the coils, obviously the amplifier valves were not drawing current and this caused a voltage rise, which was the cause of your original trouble.

ION BURN

"I have had my commercial receiver for 12 months, and I now notice that a burn has appeared in the centre of the tube. Can you tell me what causes this?"—J. A. (Bucks).

The burn is caused by bombardment of the tube by the heavy electrons which can be accentuated if the residual spot, on switching off, remains too long. Some sets are designed to cause the spot to disappear as soon as it is switched off. In the modern tube, the burn is avoided by having the electrode assembly of the tube bent and an additional magnet fixed round the neck of the tube to bring the beam on the tube for picture centring.

It would appear that your tube is nearing the end of its useful period of life.

FOCUSING PICTURE

"I have a good picture with my home-built set, but no matter how I adjust the focusing and centring device, I cannot bring the picture on the centre of the tube."—G. I. M. (Worcester).

The beam may be deflected by your particular speaker or mains transformer positioning, or the focus unit may be mounted off centre or incorrectly adjusted. If the focus unit is in the wrong position in relation to the neck of the tube, you will get shadows in the corners when trying to push the picture over and we can only suggest that you try fresh positions for the focus unit.

LOSS OF BRIGHTNESS

"I have recently noticed a drop in the picture brightness of my home-built television receiver, and the contrast sensitivity control has to be turned up to nearly maximum. Also the raster itself does not seem as bright as at first. I have checked all voltages and currents, and these are the same as when I first constructed the set."—R. D. G. (Shepherd's Bush, W.12).

The fact that brightness brings out the fly-back lines would indicate that picture strength has fallen and, in view of the hand-capacity effect and the fact that all voltages and currents are approximately the same, we think you will find that one of the early grids in the vision section has become open circuited. This would result in the valve working inefficiently and cause a weak signal. We do not think the tube will be faulty.

The only satisfactory check would be with a signal generator, transferring this from grid to grid, working backwards from the video stage. As the strength will have to be reduced on the generator at each succeeding stage, you will find that on arriving at the faulty stage, you will have to increase the signal generator output.

POOR PICTURES

"I have a television receiver which is not more than six months old, and in excellent condition. Unfortunately, I live in a block of flats and am surrounded by tall buildings, a hospital which has a large X-ray department, and a power sub-station. I have, after considerable trial and error, erected my indoor aerial (a flexible dipole) in the position where I get the best reception. I find, however, that:

"1. I cannot see the lines in the middle of the clock before the programme commences.

"2. There seems to be a filmy curtain on the left-hand side of the picture which varies nightly.

"3. The picture seems to be pulling to the left. In fact, almost invariably when I switch on the picture, it has shifted $1\frac{1}{2}$ in. to the left, and can only be brought back to position by a fractional adjustment of the line hold. Any background perpendicular lines seem to flutter about like an eel.

"4. Lastly, there is sometimes a second, fainter, image about $\frac{1}{2}$ in. to the right of the main ones.

"I know my flat is vulnerable to all sorts of interference, as even my radio is sometimes completely jammed up and I have to switch off.

"Could you advise me where to look for my troubles: a better aerial, a mains filter, or maybe a fault in the set?"—C. A. Nixon (London, S.E.1).

The second faint image can be a reflection, or the line time base may not be functioning correctly, and this could be due to an inaccurately-set frequency control or too weak a signal.

In view of the fact that you mention the tall buildings and an indoor aerial, we think it is a possibility that this is the trouble, and it may be worth while trying a pre-amplifier to see if the additional signal strength will overcome the other troubles.

LINE CONTROL DEFECT

"The line lock control (R.45) is very critical and picture can only be held with difficulty, and change of cameras will start picture slipping or rather tearing, sometimes the centre of picture and other times top one-third and bottom one-third. Interference from traffic also causes displacement of parts of picture.

"I have tested all connections for "dry joints," tried a complete change of valves, tested values of resistors, and tested condensers for breakdowns. The set has also been tried on another aerial. The "frame lock" is also rather critical, but I have no trouble in holding picture vertical. Signal strength seems to be ample, as picture is at times very good without contrast control at full gain.

"When trouble first became noticeable it could be stopped by reducing contrast, now I find that advancing brilliance control will make picture tear.

"I am also troubled by slight mains hum on sound, which can be stopped by placing metal can over detector valve. I should also add that I have converted chassis to console type (double-deck) as recommended in "Practical Television," Vol. 1, No. 2. Trusting you will be able to offer some advice."—A. R. Harris (High Wycombe).

A weak signal can give rise to the trouble mentioned, and this might be caused by an inefficient or unsuitable aerial. If, however, the performance was originally good and has deteriorated to the present condition, it would appear that either a valve or some other component has developed a fault, and the most likely valve would be the sync separator, or a condenser feeding it may have become leaky.

Advancing brilliance results in a bigger current drain on the H.T. side, and if this makes the picture tear, it would appear that the H.T. supply may be down, and this could be caused by the rectifier being in need of replacement.

REFRESHER COURSE IN MATHEMATICS

8/6. by post 9/- 4th Edition By F. J. CAMM

From: GEORGE NEWNES LTD.

Tower House, Southampton Street, Strand, W.C.2

LONDON CENTRAL RADIO STORES

PHOTO-ELECTRIC CELLS, TYPE GS18

These cells are the gas-filled type with caesium cathode, made by Gintel. Minimum sensitivity 100 ua/LUMEN, working volts 100 D.C. or Peak A.C. Protected cathode area 16 square cm. Suitable for 16mm. home cinema talkie equipment, safety devices, colour and photo matching, burglar alarms, automatic counting, door opening, etc. Brand new in original cartons. 42/6. PHOTO-ELECTRIC CELLS, TYPE CV 143.

Small infra-red image glass converter tube, 50-100 volts, suitable for all purposes, 14/6 each. We cannot enter into correspondence regarding these cells.

PILCO RADIOS

RECONDITIONED

LARGE TABLE MODEL, in light walnut. Large circular dial, very selective. 115/-

DE LUXE MODEL with bronze speaker grille. 132/-

ALL-WAVE DE LUXE TABLE MODEL. Large circular dial. 2-speed tuning. Takes normal or di-pole aerial. 174/-

CATHEDRAL MODEL, in light or dark oak, receives all British and European stations with great clarity. 110/-

A STANDARD TABLE MODEL. Square cabinet in light or medium oak. An absolute gift. Very few of these are available. 95/-

ALL TYPES have pick-up sockets. Supplied in A.C. or A.C./D.C. Cover all voltages 200-280 volts. Take extension speakers and are tested before dispatch. Have 5 valves.

23, Lisle Street, Leicester Sq., W.C.2
Telephone: GERard 2080.

ALPHA OFFERS

SPEAKERS: P.M. TYPE 2 to 3 ohms.
3in. Elac .. 12/6
5in. Goodman .. 13/6
5in. Plessey .. 13/6
10in. Rola .. 52/6
12in. Truxox .. 65/-

METAL RECTIFIERS
12 volt 1 amp. 1/-
200 volt 50 M.A. 5/6

WIRE WOUND VOLUME CONTROLS
100 ohm 10K 20K 30K, 2/2 each.

VALVE HOLDERS, PAXOLIN TYPE
International Octal, British 5 and 7 pin, 5/- doz.

Parcels of Spare Equipment, containing Resistors, Condensers, Volume Controls, Transformers, etc.

Outstanding Value .. 10/- each.

100 Bulbs, 6.3 v., 15 w., 6/6 doz.

Push Back Wire, 7 strands, Yellow, Blue, White and Green .. 2d. per yard.

H-Jet M.C. Ray Pieces .. 1/6 each.

Throat Microphones .. 2/6 per pair.

SEE OUR OTHER ADVERT.

Post Orders only. C.W.O. or C.O.D.

Please Include Postage. 2d. Stamp for List.

ALPHA RADIO SUPPLY CO.
5 B, Vinces Chambers, Victoria Square, LEEDS 1.

WALTON'S OF WOLVERHAMPTON

The leading midland dealers in ex-Government and other radio and electrical equipment. We specialise in high-grade goods at really competitive prices. Prompt attention to all mail orders, large or small.

Special offer this month:—
8in. Heavy Duty P.M. Speakers, Brand New in makers' sealed boxes, 25/-, post 1/-.

230-volt electric Soldering Irons, list price 22/6, our price 12/6, post 1/-.

Boxes of assorted nuts, bolts, washers, etc., mainly B.A. approx 1,000 items, per box 3/6, postage 9d.

Ditto useful Rivets, 2/6, postage 9d.
Polyethylene Di-Pole Insulators, 5/- each, postage 1/6.

Valves, Special clearance, all at 5/- each, post 6d. VR56, VU133, KT44, 2155G, 955, 7193, 125H7, 125J7, ATP4, EA50, 2 x 2.

WALTON'S WIRELESS STORES

48, STAFFORD STREET, WOLVERHAMPTON

TELEVISION COMPONENTS

FOR THE

"Practical Wireless"
VIEWMASTER AND E. E. TELEVISORS
IN STOCK

Price lists of specified and alternative components available on request.

Prompt Postal Service

J. T. FILMER

MAYPOLE ESTATE, BEXLEY, KENT
TEL. Bexleyheath 7267

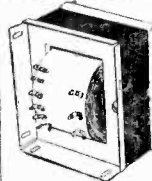

Mains Transformers UPRIGHT-DROP THROUGH AS ILLUSTRATED.

Two Types Only. Guaranteed.

No. 1: 250-0-250v., 80 MA., 0-4-6.3v., 5 amp., 0-4-5v., 2 amp. No. 2:

Same, but 350v. Both 15/-, post 1/- for 1 to 3.

HILLFIELDS RADIO, 8, Burnham Road, Whitley, Coventry

NORMAN H. FIELD

68, HURST STREET
BIRMINGHAM 5

VALVES!!!

Send for your FREE BARGAIN list of CHEAPER VALVES—

6K8, 6L6, 6K6, 6K7, 6F6, 6V6, 5U4, VU39A, 807, 1625, 6SK7, 6J5, 12SK7, 12SC7, 6SN7, Etc., Etc., Etc.

Over 20,000 Valves in stock.

Tested, Boxed, Guaranteed.

E.H.T. TRANSFORMERS, 2,500v. 5 M/a. 4v. 2 amp. 0-2-4v. 4 amp., 210-250 volts 50 cycle. Completely Wax impregnated. Guaranteed. 41/9 Ea.

SLOW MOTION DIAL with lamp-holder and escutcheon by Famous Maker, New and Boxed. 2/6 Ea.

CONDENSERS, 16 Mfd. 350 volt, can T.C.C. CE26L. 3/- Ea.

CONDENSERS, Block .5 Mfd. 2,500v. Wkg. 3/6
Block 1 Mfd. 2,500v. Wkg. 3/-

CHOKES, 60 Ohms, 200 M/a 3 1/2in. x 2 1/2in. x 2in. Potted. Suitable Viewmaster. 4/-

ROTARY CONVERTERS, approx. 6 volts input, 220v. 80 M/a. output. 12/6

G3DBL and G2FSS

Invite you to pay them a visit to help you with your T.V. Troubles.

Mail Order Dept.

64-65, Church Lane, Wolverhampton.

When you are planning to use

ALUMINIUM, LIGHT ALLOYS, BRASS, COPPER, BRONZE,

remember . . . you have a

choice of 3,000 stock sizes of

TUBE, ROD, BAR, SHEET, STRIP, WIRE, ANGLE, CHANNEL, TEE

at

H. ROLLET & CO. LTD.

6, CHESHAM PLACE, LONDON, S.W.1

Phone: SLOane 3463

WORKS:

32136, ROSEBERY AVENUE, LONDON, E.C.1

KIRKBY TRADING ESTATE, LIVERPOOL

"No Quantity too Small"

TELEVISION AERIALS

"H" type, suitable for all channels, complete with pole, chimney brackets, and lashings, 49/6.

3 Element long range type, complete as above, but with two sets of brackets and lashings, 95/-

4 Element Long Range, as above, 115/-

3 Reflector type, for cutting out interference, complete, 95/-

Please state channel required; cash with order, no C.O.D. We pay all carriage.

12H6 valves boxed, 21/6. 76 boxed, 31/6. 12SF7, 31/-

VR136, 61/6. VR137, 61/6. 6AC7, 71/6.

2 mfd. 250 v.d.c.w., 3/- doz.

SOUND TELEVISION CO.
42, ELMS ROAD, ALDERSHOT

NOW READY

For the

VIEWMASTER

(HOLME MOSS)

SETS OF COILS

WIDTH CONTROLS

BOOST CHOKES

RF CHOKES

OLYMPIC RADIO COMPONENTS,

COIL WINDING SPECIALISTS,

224, HORNSEY ROAD, HOLLOWAY, N.7

Phone: NORth 2914.

16 INCH METAL C.R. TUBE

suitable for AC/DC operation

BRITISH MADE BY

'ENGLISH ELECTRIC'

FOR MANUFACTURERS AND HOME CONSTRUCTORS

The tube offers the following advantages:

- *Magnetic focus and magnetic deflection, 6.3 Volt, 0.3 Amp. heater.*
- *High efficiency, white fluorescent screen.*
- *Brilliant picture of uniform focus on an almost flat screen, final anode voltage 14 KV.*
- *Full-screen diameter picture 11" x 14"; or rectangular picture 10" x 13".*
- *Short overall length — suitable for shallow cabinets — 70° Deflection Angle.*
- *Metal cone envelope gives lightweight and robust construction.*
- *Ion trap fitted to prevent ion burn discolouration and prolong tube life.*
- *Small-shell duodecal 5-pin base.*

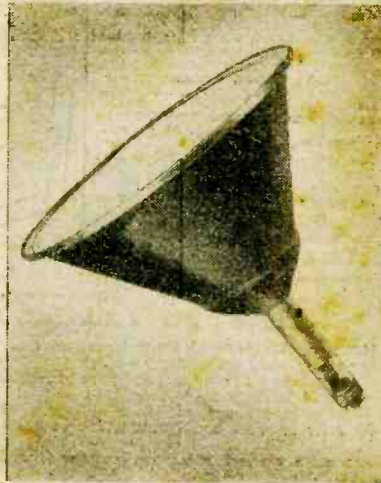

PRICE **£24.6.5** TAX PAID

For full technical details and prices for quantities write to:

The ENGLISH ELECTRIC Company Limited

TELEVISION DEPARTMENT, QUEENS HOUSE, KINGSWAY, LONDON, W.C.2