

PRACTICAL TELEVISION, JULY, 1950

NO. 4 OF THE NEW TELEVISION MONTHLY

PRACTICAL

9^D

EDITOR
F. J. CAMM

TELEVISION

A NEWNES PUBLICATION

Vol. 1 No. 4

JULY 1950



IN THIS ISSUE

Pre-Amplifier for Viewmaster
Colour Television
Television at Extreme Ranges
Simple Attenuators

Phenomenon of Fluorescence
Television Production
Television Principles and Practice
Servicing Television Receivers

CALLING HOME CONSTRUCTORS

- Build your own Television Receiver from our Easy to Read Plans.
- Don't be overcome by Alignment Snags, our Service Dept. will help you.
- Purchase the Units in easy stages. (Send for list.)

SPECIAL JULY OFFER. FULL CONSTRUCTIONAL PLANS, 2/6d.
The complete kit of parts, less tube, amounts to £20.

SEPARATE KITS

Time Base Kit ..	£5 15s. 0d.
Power Pack Kit ..	£7 10s. 0d.
Sound and Vision Kit	£6 1s. 8d.
C.R.T. Control Kit ..	£1 13s. 4d.

All complete with valves.

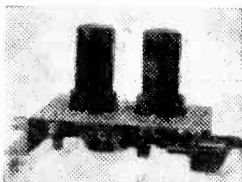

PRE-AMPLIFIERS

LONDON or BIRMINGHAM

One Valve	30/-
Two Valves	£2
With Built-in Power Pack	35/- extra

Tested and Aligned. Complete with Valves

JOIN NOW—

By becoming a member of the Constructors' Club you will be kept up to date with the new ideas in Television. Any improvements to our kit will be sent to you if you are one of the 1,000 who have built our kit. You can be put in touch with fellow constructors. **WRITE TO-DAY FOR DETAILS.**

HOUGHTON & OSBORNE LTD., THAME, OXON.

PHONE: THAME 182



SOLON electric soldering irons have proved their capacity for continuous service under the most exacting conditions. 5 models: 240 watt oval tapered bit; 125 watt oval tapered and round pencil bits and 65 watt oval tapered and round pencil bits. Each model complete with 6 feet of Henley 3-core flexible. Now available from stock. Write for order Y.10.

W. T. HENLEY'S
TELEGRAPH WORKS
CO. LTD.
51-53 Hatton Garden,
London, E.C.1

**HENLEY
SOLON
ELECTRIC
SOLDERING IRONS**

The Solder
which is
recommended
for the
View Master
and other
Television Kits



As recommended by the designer, use only ERSIN MULTICORE SOLDER—the Solder wire containing 3 cores of non-corrosive Ersin Flux. 60 ft. of 18 S.W.G. High Tin Television and Radio Solder, 60/40 alloy, is contained in Size 1 Cartons, Cat. Ref. C.16018. Price 5/- retail.

Obtainable from all leading radio shops.

In case of difficulty write to:

MULTICORE SOLDERS LTD.

Mollier House, Albemarle Street, London, W.1. REGENT 1111

The **AVO** ELECTRONIC TESTMETER

This instrument has been developed to meet the growing demand for an instrument of laboratory sensitivity built in a robust and portable form, for use in conjunction with electronic and other apparatus where it is imperative that the instrument should present a negligible loading factor upon the circuit under test.

The instrument consists basically of a balanced bridge voltmeter. It incorporates many unique features and a wide set of ranges so that in operation it is as simple to use as a normal multi-range testmeter.

The instrument gives 56 ranges of readings as follows:—

- D.C. VOLTS :** 2.5mV. to 250V. (Input Resistance 11.0 megohms.)
25mV. to 10,000V. (Input Resistance 110.0 megohms.)
- D.C. CURRENT :** 0.25 μ A. to 1 Amp. (250mV. drop on all ranges.)
- A.C. VOLTS :** 0.1V. to 2,500V. R.M.S. up to 2 Mc/s. With diode probe external 0.1V. to 250V. R.M.S. Useful measurements can be made up to 200 Mc/s, the applied voltage being limited to 100V. above 50 Mc/s.
- A.C. OUTPUT POWER :** 5mW to 5 watts in 6 different load resistances from 5 to 5,000 ohms.
- DECIBELS :** -10db. to +20db.
- CAPACITANCE :** .0001 μ F. to 50 μ F.
- RESISTANCE :** 0.2ohms to 10 megohms.
- INSULATION :** 0.1 megohm to 1,000 megohms.

The instrument is quickly set up for any of the various tests to be undertaken, a single range selector switch automatically removing from the circuit any voltages and controls which are not required for the test in question.

Write for fully descriptive pamphlet.

Sole Proprietors and Manufacturers:

The AUTOMATIC COIL WINDER & ELECTRICAL EQUIPMENT CO. LTD.
WINDER HOUSE • DOUGLAS STREET • LONDON • S.W.1 Telephone: VICTORIA 340:19

F.T.M.3



£35

Sizes : 12½ins. x 9ins. x 5½ins.
Weight : 12½lbs.

The instrument operates on A.C. mains, 100-130V. and 200-260V., 50-60 c/s.

★ THE DESIGNERS SPECIFY

V1, V2, V3, V5, V6

COSSOR 63 SPT

R.F. PENTODE

Price 17/6 plus 3/10 P. Tax

V4

COSSOR 6AL5

DOUBLE DIODE

Price 9/- plus 2/- P. Tax

V7

COSSOR 0M4

DOUBLE DIODE TRIODE

Price 9/6 plus 2/1 P. Tax

and for the
Pre-Amplifier

COSSOR 6AM6

R.F. PENTODE

Price 17/6 plus 3/10 P. Tax

**Keen
constructors
choose**

COSSOR

for the

**“VIEW
MASTER”**

LEAFLET giving full details of all Cossor Valves free on application to
A. C. COSSOR LTD., Highbury Grove, London, N.5

CT23

Where voltages are HIGH

.... choose
'VISCONOL'
Cathodray Condensers

The 'Visconol' Process—exclusive to T.C.C.—means greater dependability and a longer useful life than ever before. It is the answer by T.C.C. research engineers to the insistent demand for condensers which will stand up to higher and still higher voltages. A selection from the range is given on right: full details on request.

- ① LOW POWER FACTOR
- ② COMPLETE DIELECTRIC STABILITY
- ③ RESISTANT TO VOLTAGE SURGES
- ④ AMPLE RATING AT HIGHER TEMPERATURES
- ⑤ PROOF AGAINST BREAKDOWN OR FLASH OVER

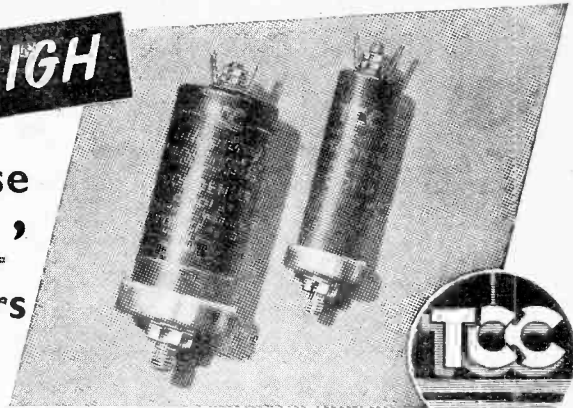

CAPACITY in Mfds.	MAX. WORKING VOLTS (at 60° C.)	DIMENSIONS IN INCHES		TYPE NUMBER
		Overall Length	Overall Diameter	
.0005	25000	5 1/8	1 3/8	CP57H00
.001	6000	2 1/2	1 1/8	CP55Q00
.001	12500	3	1 1/8	CP56V00
.002	18000	5 1/8	1 1/8	CP57X00
.0025	3000	2 1/2	1 1/8	CP55H00
.005	6000	3	1 1/8	CP56Q00
.01	6000	3	1 1/8	CP56Q00
.05	6000	5 1/8	1 1/8	CP57Q00

T.C.C. Condensers are exclusively specified in the View Master—the Television Set you build at home from standard parts. Constructor Envelopes (Model A, London, or Model B, Sutton Coldfield) 5/- each from all Wireless Shops.

Radio Division: **THE TELEGRAPH CONDENSER CO. LTD., NORTH ACTON, W.3.** Tel: ACORN 0061

'PRACTICAL WIRELESS'
TELEVISION RECEIVER

Specifies
Stentorian

THE CHOICE OF THE EXPERT

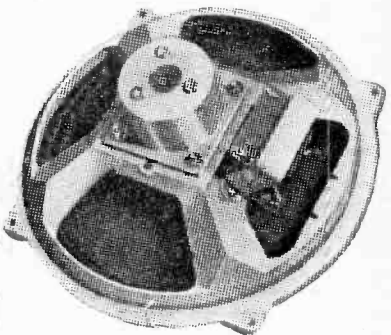

TYPE S.1012T
10" CHASSIS

Mr. F. J. Camm, by specifying a "Stentorian" for the Television Receiver described in this issue, has emphasised anew the reliability of these popular speakers. The S.1012T incorporates a 7000 ohms transformer specially designed for the 'P.W.' circuit, has a cone diameter of 10", a flux density of 12,000 gauss

(total flux 47,400) and a handling capacity of 10 watts.

It is recommended that only specified components are used in the construction of this Receiver. You will readily appreciate the outstanding performance of the "Stentorian" speaker chosen by the designer.



WHITELEY ELECTRICAL RADIO CO. LTD · MANSFIELD · NOTTS

PRACTICAL TELEVISION

Editor: F. J. C. CAMM

Editorial and Advertisement Offices: "Practical Television," George Newnes, Ltd., Tower House, Southampton Street, Strand, W.C.2. Phone: Temple Bar 4363. Telegrams: Newnes, Rand, London.

Registered at the G.P.O. for transmission by Canadian Magazine Post.

Vol. 1. No. 4

EVERY MONTH

JULY, 1950

Televiews

TV Exchange With France

THE recent television broadcast from Southend demonstrated that experiments by the Post Office, the B.B.C. and manufacturers in relaying TV on centimetric wavelengths have been extremely successful. A four-link system was used in these broadcasts, in which the Outside Broadcast van transmitted to a local station at Leigh-on-Sea from whence it was relayed to the experimental ultra-short-wave station on Wrotham Hill. This station relayed to Senate House, Bloomsbury, and from there the signal was retransmitted by co-axial cable to Alexandra Palace. A distance of about 22 miles separated the two main radio links.

It is within our knowledge that experiments on centimetric wavelengths have been carried out for many months past, and so we may safely assume from the demonstrations given that further developments may soon be expected in the TV exchange service with France. The distance between the links is the greatest which has yet been attempted on these micro wavelengths. The experiments show that cross-Channel programme exchange is more than a scientific probability, although the one technical hitch likely to delay its introduction as a regular service is the final decision as to the number of lines per picture ultimately to be used in France. Although it is possible for pictures to be transmitted on one frequency and re-broadcast on another, there is some sacrifice of picture quality under such a system. It would be better if international agreement could be reached on the subject of picture frequency and lines. The French system at present is 525 lines, whereas the English system is 405. A study group of the International Radio Consultative Committee met in London in May to continue its examination of the technical factors controlling the co-ordination of television standards. This committee, which was appointed in Stockholm in 1948, held its last meeting at Zurich in July, 1949. Representatives of Austria, Denmark, France, Netherlands, Sweden, Switzerland, Great Britain and U.S.A. were present at the meeting. Previously the delegates had visited the U.S.A., France, Holland and Great Britain to inspect television systems and work in progress in research establishments. It will be some time, of course, before a report is issued, and it may be even longer before any recommendations made are adopted. It is essential that some universal standard should

be agreed at the present stage of television development if it is to provide a world-wide service. It will be too late in five years' time.

100 SPORTS PROGRAMMES A YEAR

THE Postmaster-General has announced that following the meeting between representatives of the Post Office, the B.B.C., the Radio Industry, and leading personalities in the sports world, agreement has been reached, and in the result 100 sports programmes are to be televised each year. In a speech to the Radio Industries Club he said that there could be no doubt that television will play as big a part in the last half of this century as the cinema played in the first half. There is no form of social, cultural or educational activity which television cannot invade and in this respect it has the world at its feet. It will become a firmly established amenity for the people of the future. It will give the home an individual significance; it may even cause a change in our educational system, because homework for school children will be almost impossible when television is installed in the home. It is bound to effect changes in our national habits if, as is suggested, it is going to keep people in the house. Mr. Edwards issued this warning to those who are opposing, or who are likely to oppose, the development of television: "It is no use fighting against the development of television. I say to those whose financial interests may be imperilled by its development, that they have got to so re-orientate their activities as to ride with the tide, because if they do not ride with the tide, television developments will completely overwhelm them."

He said that the 405-line system will remain with us for some years. This system was adopted to provide a good picture and to enable manufacturers to produce television receivers within the purchasing capacity of the public.

When colour television arrives it will be easier to change from 405 to colour than from 605, and such a change will thus have the least effect upon production. Our television is undoubtedly far ahead of anything in Europe.

He announced the formation of the Sports Television Advisory Committee which would consist of representatives of the Sporting Associations and the viewing public, and in this matter the national interest must come first—F. J. C.

BUILDING THE "View Master" Pre-amplifier

Constructional Data for a Single Valve Unit

By ALAN CHISHOLM

JUDGING from numerous reports on the performance of the "View Master," by constructors of both the London and Birmingham models, there seems little doubt that it is a completely reliable and highly sensitive receiver over the normal service areas and, indeed, satisfactory results have been obtained in some districts considered outside the accepted transmission range.

Obviously, however, signal strength must fall off the farther the distance from the transmitting station (disregarding other factors) until the point is reached where reception is below the acceptable standard. If you are living in one of these fringe areas, you need not be debarred from the pleasure of building and looking in with a "View Master," for a pre-amplifier unit has been designed which increases the sensitivity of the standard model and gives good reception.

The need of a pre-amplifier in areas of low signal strength, was, of course, appreciated when the standard "View Master" was designed and space has been allowed for it at one corner of the Sound/Vision chassis, when necessary. There is an adequate reserve of power from the existing power pack to meet the additional H.T. and heater current required.

From the circuit diagram it will be seen that the pre-amplifier is a single-stage R.F. unit of simple design and few components, most of which are standard parts. The Alexandra Palace and Sutton Coldfield models are identical except for the tuning coils, which obviously have to be tuned to different frequencies, and a difference in value of some of the damping resistors.

The reason for the latter is explained in the fully illustrated constructional leaflet now available.

An all-glass H.F. pentode valve having a B7G base is used, and either a Cossor 6AM6, Mazda 6F12, Mullard EF91 or Osram Z77 is suitable.

The aerial is coupled to the grid of the valve in exactly the same way as in the first stage of the "View

Master," and this complete isolation from the receiver eliminates the danger of shock.

Construction

A chassis can be made up from tinplate from the template included on the constructional leaflet, or bought complete with valvholder and terminal strips as specified in the list of components required. If made up at home, fit the valvholder with pin No. 1, nearest to the side on which condensers CP4 and CP5 are to be fitted, and then the terminal strips. Turn back the tags of pins Nos. 3 and 6 of the valvholder and solder to the chassis. The large centre socket of the valvholder must also be earthed to a convenient point. Now fit the four Micadiscs into position from the outside of the chassis and fix by turning back the tags on each and soldering down.

Solder short lengths (say $\frac{1}{2}$ in. long), of tinned copper wire into the centre terminal of Micadisc condensers CP2 and CP3. To the centre terminal of Micadisc condenser CP4, solder a $4\frac{1}{2}$ in. length of wire passing it through from the outside so that it projects inside by approximately $\frac{1}{4}$ in. Treat condenser CP5 in the same way except that the wire must project inside by about $1\frac{1}{2}$ in., and should measure about 5 in. overall. The free end of this wire inside the chassis must be soldered to the tag of pin 4 of the valvholder, but turn it back for the moment out of the way and make this connection at the last.

Fit resistors RP3 and RP5 in the following manner. Make a loop in one of the leads near the body of the resistor, slip the loop over the wire already soldered to the centre terminal of the appropriate Micadisc and continue the resistor lead to the correct valvholder tag. The free end of the resistor RP5 can then be looped and slipped over the wire projecting through condenser CP4 and soldered, and the free end of resistor RP3 conveniently earthed. Where there is more than one con-

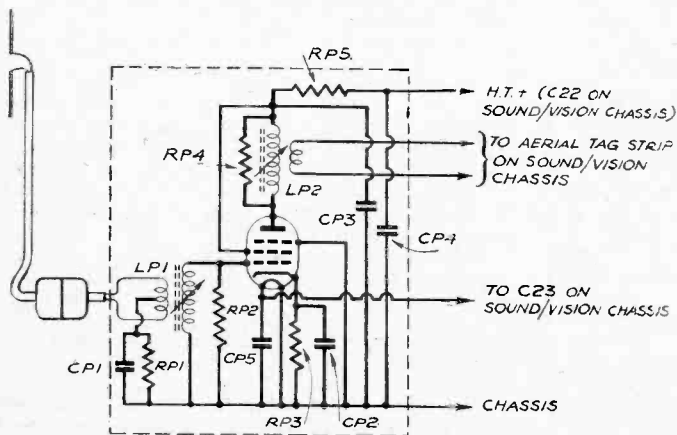

Fig. 1.—Theoretical circuit of the pre-amplifier.

LIST OF COMPONENTS

- Whiteley chassis type WB300.
- T.C.C. capacitors
 - One Metalmite CP119W.
 - Four Micadiscs CM30.
- Morganite resistors
 - Five type "T." Values according to model.
- Wearite R.F. coils
 - One aerial coil type LP1 (A) (London) or type LP1 (B) (Midlands).
 - One Anode coil type LP2 (A) (London) or type LP2 (B) (Midlands).
- H.F. pentode valve with B7G base—
 - Type Cossor 6AM6, Mazda 6F12, Mullard EF91 or Osram Z77.

nection to be made to a valveholder pin tag, insert the wire or lead into one of the small holes, take a turn round the tag and leave until all connections have been made, when the whole joint may be soldered in one go, so as to prevent any possible damage through repeated heating.

Now identify the coils. LP1 is that which has a centre tapped primary winding, to be connected to a common point formed by the positive terminal-lead of condenser CP1 and one end of resistor RP1.

It must obviously be mounted so that this centre tap faces towards the condenser. Before mounting, however, shorten this centre tap and clean off the insulation. Also, on both coils, measure off the length of the leads to the appropriate connections and clean off the insulation. This is more easily accomplished before mounting. Do not shorten these leads at this stage.

Fit the condenser CP1 with the positive end just projecting inside and fix by soldering the clips to the top of the chassis and at the same time earth the negative lead at this point. The positive terminal-lead of CP1 is connected to the centre tap of LP1 and also to one end of resistor RP1, the other end of this resistor being earthed. The ends of the primary winding can be threaded through the holes in the terminal strip, given a turn round the tags and soldered on the outside. This is easier, in my opinion, than connecting inside. The lower end of the secondary winding is earthed and the upper end connected to valveholder pin No. 1. At this tag, resistor RP2 is also connected, the other end being earthed.

In mounting coil LP2 remember that the secondary winding, i.e., the outer winding of $1\frac{1}{2}$ turns must naturally face the output terminal strip, to which it is connected in a similar manner to that described above. The lower end of the primary winding is connected to pin 5 of the valveholder and the upper end to pin 7, and resistor RP4 is connected between these same pins.

The lead from the centre terminal of condenser CP5 can now be soldered to the tag of valveholder pin 4, and an earth bonding wire completes the internal wiring, not forgetting the soldering of the multiple connections.

The pre-amplifier may be bolted or soldered in position on the Sound/Vision chassis but soldering is probably easier in a completed receiver.

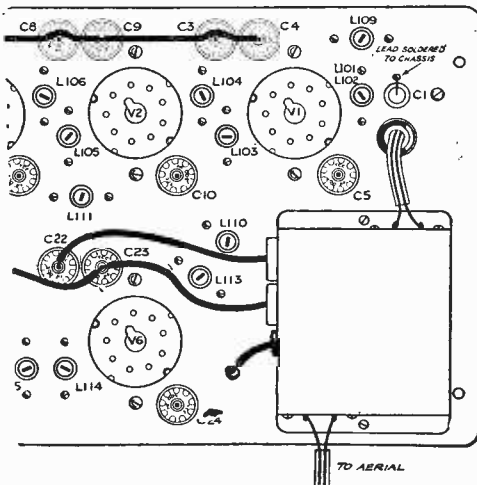

Fig. 2.—Layout of the pre-amplifier.

The unit is wired in series with the existing aerial feeder which is, of course, cut and shortened as necessary.

Current for H.T. and heater is picked up from Micadiscs C22 and C23 respectively, on the top of Sound/Vision chassis, to which the leads from CP4 and CP5 on the pre-amplifier are connected. The joint

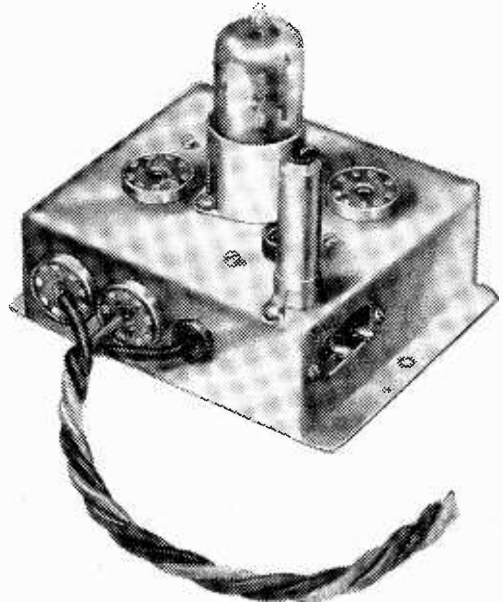

Fig. 3.—A view of the completed unit.

at C23 is quite straightforward, as if you have adopted my method for connecting Micadiscs, there will be sufficient wire still projecting for easy soldering. To connect up to C22, follow my instructions for a similar connection to C16 in my third article on "Building the View Master."

Operation

To operate the "View Master" with this added unit, the aerial and anode coils LP1 and LP2 are merely tuned for maximum signal. No other aligning adjustments are necessary.

CLUB REPORT

MISS MARY MALCOLM, television announcer, paid a welcome return visit to Croydon on Monday evening, May 15th, when, accompanied by producer S. E. Reynolds, she addressed members of the British Television Viewers' Society at their monthly meeting at Kennard's Restaurant.

Miss Malcolm, as well as recounting her early experiences as an announcer, spoke on the technique of building-up a feature such as the topical "Your Wardrobe." Mr. Reynolds discussed producing in general, mentioning in particular the weekly magazine programme, "Picture Page," which he has had the task of producing on very many occasions.

A bouquet was handed to Miss Malcolm during the evening as a small token of the esteem in which she is held by the Society; a similar gift was sent to Miss Joan Gilbert, editor of "Picture Page."

TELEVISION CITY

Some Details of the New B.B.C. Site at White City

BEFORE the war the B.B.C. was seeking a suitable site on which to build permanent studios and ancillary accommodation in London because the studios at Alexandra Palace were neither adequate in size nor sufficient in number. On the cessation of hostilities the search was resumed. In 1947 the Corporation decided that the White City Exhibition site at Shepherd's Bush was on the whole the most favourable of the many sites which had been considered.

Negotiations for the acquisition of the site began in 1947 with the Exhibition Company, but after some progress had been made it was learnt that the L.C.C. had plans to acquire the whole of the site for housing. In August, 1947, the B.B.C. represented to L.C.C. officials that the Corporation was experiencing the utmost difficulty in finding a large enough site on which to build, *inter alia*, premises for the television service. The B.B.C.'s representations were most sympathetically considered by the L.C.C. and the Corporation was informed some months later that it had been agreed in principle that the B.B.C. should be permitted to acquire approximately 13 acres of the White City site.

By August, 1948, it had become clear that the B.B.C. might go ahead on the assumption that the site would be available. Long-term and short-term reviews of the Corporation's building and accommodation problems in the London area were accordingly carried out in order that a decision might be taken as to which of the B.B.C.'s activities could, with best advantage to the sound and television services, be housed at the White City. It was later decided that highest priorities should be given to the development of approximately half the site for the television service in the first instance and that no commitments for the development of the remainder of the site should be made in the meanwhile.

A Stop-gap

Limitations imposed on capital investment under the national building programme later showed it to be impracticable to complete sufficient accommodation for television on the White City site in time to replace the Alexandra Palace when the lease of those premises expires in June, 1956, and to provide for expansion. In order to bridge the gap and to provide additional

studios for television immediately, the Corporation acquired film studios in Lime Grove, approximately half a mile from the White City. These studios were suitable for quick conversion and occupation as temporary television studios until such time as the move to the permanent building at the White City could take place.

It was originally intended that a planning competition should be instituted in connection with the development of the site as a whole. It was later decided, however, that this would be unsuitable having regard to the necessity for maintaining a considerable degree of flexibility as to the eventual use of the second half of the site. Instead, the B.B.C. invited the President of the Royal Institute of British Architects to submit names of architects considered suitable for a project of this kind. From the recommendations received, the Corporation chose Graham Dawbarn, C.B.E., M.A., F.R.I.B.A. (Norman & Dawbarn), who, on November 18th, 1949, was appointed, in association with M. T. Tudsbury, C.B.E., M.I.C.E., the B.B.C.'s Civil Engineer. Early in the present year (1950) an architectural conception had been evolved which was deemed by the B.B.C.'s professional advisers (Howard Robertson, M.C., A.R.A., F.R.I.B.A., and W. G. Holford, M.A., F.R.I.B.A.) to provide a striking architectural solution of requirements, taking into account the problem of neighbourhood and site conditions generally. The proposals were thereupon considered by the Board of Governors of the B.B.C. and adopted as being distinctive and at the same time having character, originality, and fulfilling their function. It was decided at the same time that the "user" of the second half of the site, so far as detailed planning was concerned, should remain open.

The B.B.C. hope to build and occupy the premises progressively; and, subject to the limitations of capital investment, plan to have the scenery block completed by the end of 1952 so that it may serve scenery to the Lime Grove Studios (see paragraph 4 above) until such time as the multi-storey block, and large studios Nos. 1 and 2, with the presentation suite, and the canteen—all of which would form an "operational unit"—are built and equipped.

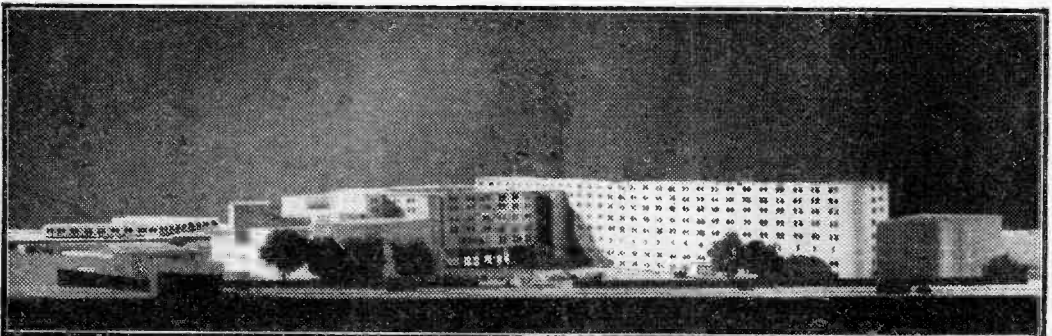

How the finished B.B.C. Headquarters will appear when completed.

TELEVISION PRINCIPLES AND PRACTICE

4.—The Electron Multiplier (contd.).—The Iconoscope—Cathode-ray Tubes By F. J. CAMM

THE frequency is adjusted so that a half cycle occurs at approximately the same time that the electrons are passing from A to A1 (Fig. 12, June issue). Electrons entering the multiplier at the moment when the electrode A1 is about to become positive are attracted to it with an increasing velocity and upon impact with it they release a large number of secondary electrons. Now, as the oscillator frequency is adjusted so that one half cycle is coincident in time with the electron transit time, the secondary electrons will be emitted at the same instant that the electrode A is becoming positive with respect to A1. Thus they move across to A, releasing more secondary electrons which begin to move towards A1. This cycle operation is repeated at an enormous rate. The circular anode collects a high percentage of these electrons and develops a voltage across the resistance R (Fig. 12), from which point the usual amplification occurs. There are, of course, many types of electron multiplier, some not needing an oscillator.

The Iconoscope

The Iconoscope, which is the basis of the television scanning camera, was invented by Dr. V. K. Zworykin. The diagram, Fig. 13, reproduced from our first issue, shows the general principles. It will be seen that it incorporates a photo-sensitive electrode, which instantaneously converts the received image into electrical impulses without the difficulties attending scanning. The principal advantage of this arrangement is shown in a later chapter. The image is focused on to a plate covered with the minute grains or cells as mentioned later, but these are also electrically arranged in such a manner that they are insulated from one another. The application of an image (through a lens) focused on to the plate results in a certain flow of current through the circuit and thus influences the transmitter according to the detail which is received by the plate. At the receiving end, the received impulses are fed to a fluores-

cent screen of a cathode-ray tube and reproduce the image.

The television system adopted by the B.B.C. makes use of scanning in a horizontal direction (this applied to both of the systems at one time employed). In Continental and American systems, horizontal scanning is also employed. In the English systems scanning takes place from the top left-hand corner of the area being televised, each spot of light travelling from the left to right of the area in the form of a strip, each succeeding strip building up the picture.

It will be apparent that the Iconoscope is really a development of the cathode-ray tube and is probably one of the greatest achievements in television research. It has often been referred to as a "cathode-ray tube with a memory." The Iconoscope is used for transmitting purposes in conjunction with a cathode-ray receiver, and after exhaustive tests such an all-electric system has proved considerably more efficient than any arrangement which depends for its functioning upon mechanically-operated devices. The Marconi-E.M.I. system makes use of the Iconoscope principle in the Emitron camera.

In order to understand the functioning of the Iconoscope it is first necessary to consider how the cathode-ray tube functions. An electron stream liberated by a cathode and applied to a phosphorescent screen is controlled by what is known as an electron gun and various deflecting plates and coils. By applying varying alternating potentials to the deflecting plates the stream can be made to move backwards and forwards in a horizontal line so as to traverse a complete rectangle. If the beam is modulated by the received television signals, it will produce numerous spots of light of different intensities on the phosphorescent screen. The result of the action referred to is to form a complete picture.

In the case of the Iconoscope the phosphorescent screen

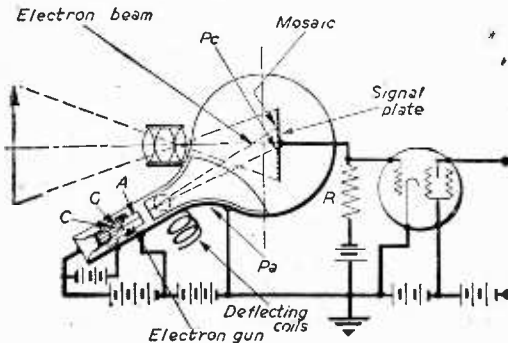

Fig. 13.—Diagram of the television camera.

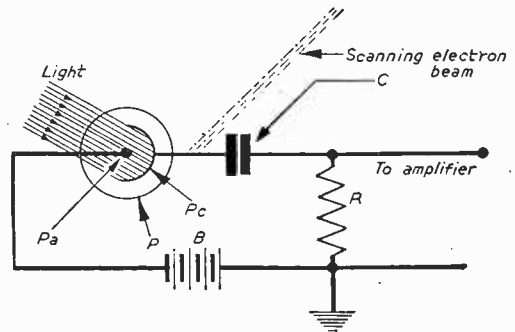

Fig. 14.—Diagram showing the condenser action of each cell.

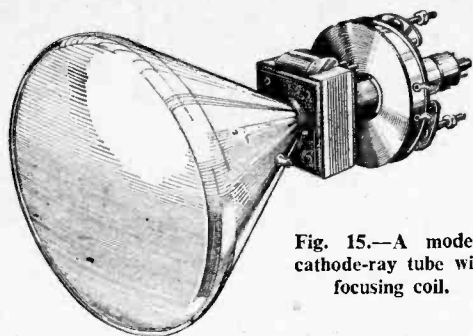

Fig. 15.—A modern cathode-ray tube with focusing coil.

is replaced by the millions of minute photo-electric cells mentioned earlier.

A general arrangement and method of functioning of the Iconoscope, or electric eye, was shown in Fig. 4 (May issue, and reproduced on page 151), where the picture which is to be transmitted is focused by means of a lens on to the mosaic bank of photo-electric cells, inside the tube. The varying light intensities applied to this mosaic of cells produces an electrical change, which can be compared with the chemical change taking place on an ordinary photographic plate when the camera lens is open and focused. When this is done, each individual cell of the mosaic liberates a certain number of electrons proportional to the intensity of the light directed upon it. This results in the cells (which act as minute condensers) becoming charged. The principle of the charging action can be followed in Fig. 14, where one of the tiny cells is represented at C. As light falls upon its sensitised surface some free electrons are liberated with the result that there is a surplus charge of positive electricity on one plate of the condenser and a corresponding negative charge on the other.

The next step is to convert the electrical charges built up on the condensers into corresponding signal currents, which can be used (after suitable amplification) to modulate the carrier wave of the transmitter, so as to radiate the electrical equivalent of the complete picture. At this juncture an important advantage of the Iconoscope comes into play. The electrode assembly in Fig. 13 is set in the path of the electron stream produced by the "gun," which acts as a scanning beam as it passes to and fro over the cells; the beam discharges each cell in turn and causes a series of current surges to pass through a resistance R, which is connected in the input circuit of the amplifier. Each pulse of current is the electrical equivalent of the light intensity of a particular portion of the original picture. Consequently, it will be seen that the whole of the original picture is converted into its electrical counterpart by the charging action of the bank of cells. These charges are afterwards scanned in correct sequence by the electron beam, and thereby applied to the amplifier and thence to the transmitting apparatus proper.

At the receiving end the signals are applied to an ordinary type of cathode-ray tube, and the electrical pulses are thereby reconverted into points of light which are of varying intensity.

The result is that the picture seen on the fluorescent screen of the cathode-ray tube is identical with that focused on to the bank of photo-cells of the transmitter.

A particular advantage of the Iconoscope is for the transmission of outdoor scenes. This is because the picture to be transmitted is constantly focused upon the

mosaic cells, so that they are constantly building up a charge during the complete length of time between one scanning period and the next. This permits of the formation of a much stronger electrical image than can be obtained by normal methods of scanning, where the spot of light rapidly passes over the picture, and is only applied to the photo-electric cell for a very short time. As a matter of fact, the response of the cell to a ray of light which rests on it for one twenty-fifth of a second is 40,000 times stronger than it is to an impulse which lasts barely one-millionth of a second. It is clear, therefore, that the Iconoscope has this much more energy in hand, for which reason it will operate efficiently in outdoor conditions—and even in dull weather—when television by ordinary methods is not practicable.

The Iconoscope has an advantage over the image dissector in that electron multiplication is not necessary. The current passing through the resistance during each globular discharge is of a comparatively large order, because the number of electrons moved round the circuit is equal to the total number emitted photo-electrically by a globule of the mosaic since the previous scanning.

So that if the picture area is scanned completely 25 times per second, then the whole of the photo-electric emission of a globule over a period of at least one twenty-fifth of a second is utilised, instead of only the emission during the very small instant of actual scanning. There is, of course, a small amount of leakage between globules, but the output from the Iconoscope is much greater than that from the image dissector not employing electron multiplication.

Cathode-ray Tubes

All television receivers to-day employ cathode-ray tubes in which the light spot, which is focused on to the fluorescent screen, is varied in intensity by the magnitude of the received signals, at the same time that it is caused to scan the surface of the screen in a series of lines and frames, somewhat similar to the system of scanning already described.

Both electrostatic and magnetic scanning is employed to-day, saw-tooth waveforms producing the necessary movements. The deflecting waves at the receiver are synchronised exactly with those at the transmitter by a method to be described later. The position of the cathode spot on the screen of the receiver tube is always in the same relative position as the picture element being scanned at the transmitting camera.

The fluorescent screen has a slight after-glow (light persistence), and this is just less in duration than the time taken to scan one frame of the picture, and this gives a fair compromise between flicker and blur.

Erratum.

The last two lines of the June article should read: ". . . of about 50 megacycles per second."

(To be continued.)

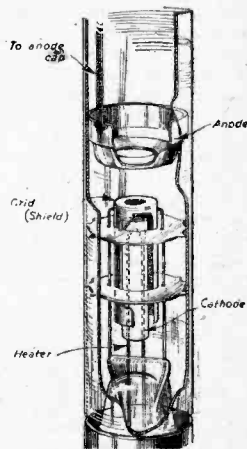

Fig. 16.—Electrode assembly of a cathode-ray tube.

COLOUR TELEVISION

A Reader Looks at this Problem from a Different Angle. Will It Work?

By G. KEATING

IT must be many years before a system of colour television is in use in every home, and in the meantime any system put forward must be one capable of providing a standard black-and-white picture for the less ambitious set owner.

This at once confines the design within certain limits, more especially if the use of existing bandwidths and transmitting equipment is contemplated. With the foregoing in mind it is inevitable that development (at least of an interim system) must be designed round sequential colour scanning. This means simply that one picture element is transmitted containing all the red colouring of the picture, and this will be followed by another element containing, say, the blue portion.

The colour receiver will superimpose these images in colour, thus giving a coloured picture, whilst the cheaper receiver will show both pictures in black and white on a single tube as at present. So far, so good. When we come to look into details, however, a number of snags appear. In the past a variety of methods have been demonstrated giving perfect colour presentation and balance. They have, unfortunately, been laboratory instruments only capable of continuous use if in the hands of expert manipulators. Any system of mechanical colour separation using (for instance) fan blades must be ruled out owing to the difficulties of producing "works" which will stand up to long periods of use without attention.

The system outlined below in brief will overcome all these difficulties in one sweep, and, moreover, will provide a picture with the same definition as at present, but with a very reasonable colour presentation. Existing bandwidths are quite adequate, and the present set user will be able to continue receiving his black-and-white picture exactly as today without anything to show that his more fortunate neighbour is viewing the self-same scene in colours.

How It Works

For simplicity and reliability the existing interlaced scanning is retained, and two colour-elements will be needed. One will cover the red/orange spectrum, and the other the blue/green spectrum. If the two colour filters are suitably harmonised a very close approximation of full-colour presentation is produced. And now let us see how this will be achieved in practice.

Having ruled out mechanical colour switching as cumbersome we are left with electronic switching as our alternative. The simplest—though by no means the cheapest—method is to use two tubes in the transmitting camera, each with its own colour filter and a square-wave multivibrator to cut the two tubes in and out, alternatively.

A Problem

Here we meet our only problem in the mechanical sphere. If we hold a pencil at arm's length and gaze steadily at it for a few moments, and then with *fixed gaze* we move the pencil nearer, we begin to "see double." The cure for this is that we must relax our fixed gaze and permit our eyes to turn inwards so that at all times each eye is pointing directly at the pencil. In

our two-tube camera we must mechanically arrange for the tubes both to point towards the point of focus at all times to achieve the same end. The camera, then, in simplified form will be something thus :

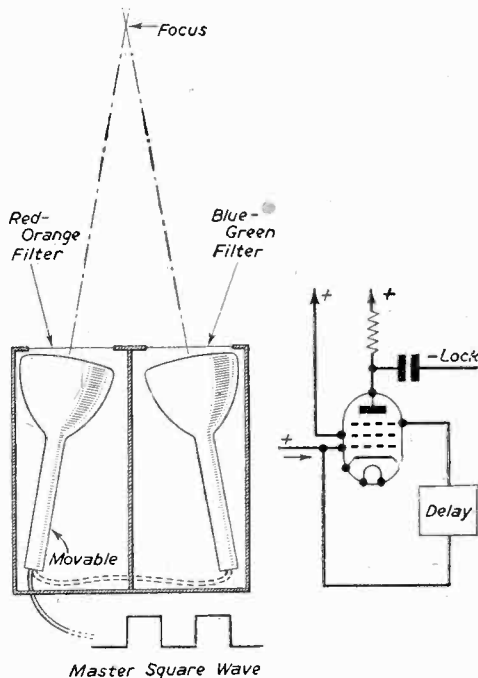

Figs. 1 and 2.—Method of mounting tubes, and a suitable gating circuit.

With this camera a normal interlaced picture will be transmitted as at present except that for one frame the "high lights" will be from the red tube and the next from the blue. This will not make any difference to the ordinary viewer since, apart from the sensitivity of the camera not being (in photographic terms) "orthochromatic" at present, any bright light of whatever colour must be reproduced on the receiver as white. By transmitting one colour at a time we can use the whole of the existing bandwidth for each element, and no deterioration of definition creeps in.

Here, then, we have a method whereby we can, with the minimum of extra equipment, transmit a picture capable of being reproduced at the receiving end either black and white, or in colour.

Before we finally leave the transmitter side we must bear in mind that the master square-wave used for colour switching must also be generated, and locked, in synchronism at the receiving end for correct colour switching. Furthermore, we have postulated that this must not interfere with the less fortunate black-and-white viewer. How best can this be done? Since our colours

are to be switched at the end of each frame the answer would seem to be: "Fit a free-running multivibrator in the receiver and lock it to the 'frame sync'." This does, in fact, work—sometimes! However, chances are 50-50 that the reds will be green and the greens will be red owing to the inability of the multivibrator to distinguish between successive frame sync. pulses. To distinguish one from the other we must make the frame sync. pulses alternatively long and short. The differences must not be great or our "black and white" friend will run into trouble with *his* receiver. By slightly shortening the present duration of frame sync. pulse for the red scan, and slightly lengthening it for the blue scan, we can, with the aid of a suitable "gating" circuit, pick out the longer of the two pulses with ease

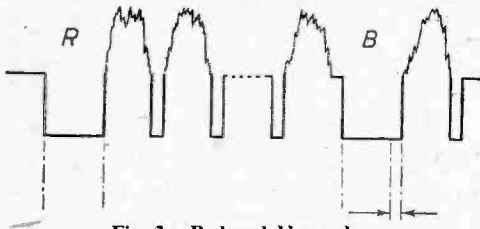

Fig. 3.—Red and blue pulses.

and ensure that our colours are "in phase," i.e., that reds are red. One gating method which would be satisfactory for sorting the pulses is that shown in Fig. 2, in which the pulse is fed direct to the grid, and *via a delay network* to the suppressor grid. The valve is heavily biased on both control grid and suppressor, and unless both grids are made less negative simultaneously no signal appears at the anode.

If the delay be adjusted so that the time lag be equal to the duration of the red sync. pulse R in Fig. 3 the grid will have become negative once again before the suppressor is unbiased. When the blue pulse B comes along, however, the grid will remain open for a short while after the suppressor is open, and a negative locking pulse of considerable amplitude but short duration will be available at the anode—just what we require for a steady lock.

The Receiver

We have now finished with our "interfering" with the transmitter. We have secured two sets of coloured signals, with a means of discriminating between the two; and we have achieved all this whilst leaving our neighbour with his normal black-and-white picture unimpaired.

Last of all comes the question of presentation to the viewer. Since a little while must elapse before such a system could be brought into use it would be a retrograde step to consider any other method of presentation than projection-tube operation. Whilst projection tubes and their concomitants will be costly items for some time yet, the use of R.F. oscillators for E.H.T., with consequent reduction in capacitances required for high-voltage smoothing, also the use of plastic lenses in place of optically-ground glass, will contribute to bring this method within reasonable limits before long. The use of tubes having suitable screens for fluorescing in the required shades of red and green instead of the less efficient coloured filters is a minor detail to our "tube boffins." And so here's to the time when the tuning signal shows two new words on the screen: *red* (in RED) and *green* (in GREEN).

Television Filmstrips in Colour

FOLLOWING the success of their series of film-strips on "The Radio Valve," the Technical Publications Department of Mullard Electronic Products, Ltd., have recently introduced two new filmstrips describing the "mechanism" of television and the general features of television receiver circuits.

The instructional value of these two new filmstrips is greatly enhanced by the judicious use of colour. For example, in curves and diagrams it facilitates the differentiation between a number of variables, e.g., voltage, current, and the sound, vision and synchronising signals. It is also extremely useful for illustrating the basic principles of operation of such devices as the television camera or iconoscope, and the cathode-ray tube.

The two new filmstrips have been produced with the co-operation of the National Committee for Visual Aids in Education, and are being distributed by "Tartan" Filmstrips, price £1 complete with summarised lecture notes. Detailed lecture notes are available from the Mullard company, either for use as a basis for more extended lessons or for verbatim delivery before scientific or radio societies. The Mullard Educational Service is at all times willing to assist teachers and lecturers by providing additional technical data.

Principles of Television

The filmstrip "Television," Part I (Number 7 in the Mullard Series), comprises 18 frames, and describes the basic principles of television transmission and reception. It is suitable for senior classes in secondary schools and as an introduction to the subject of television in technical colleges, training centres, radio societies and radio trade associations.

The filmstrip "Television," Part II (Number 8 in the Mullard Series), comprises 30 frames, and develops the subject in more detail.

Mullard Electronic Products, Ltd., were one of the first companies in this country to realise the very great value of filmstrips in technical education.

Some thousands of Mullard-sponsored filmstrips are already in regular use throughout the country, and there is a continual demand for more educational films of this kind. There is no doubt that the two new colour filmstrips on television will help to satisfy this need and will at the same time make a notable contribution to technical education.

NEWNES' RADIO ENGINEER'S POCKET BOOK

By F. J. CAMM

5/-, or by post 5/6

Obtainable from booksellers, or by post from
George Newnes, Ltd. (Book Dept.), Tower House,
Southampton Street, Strand, W.C.2.

Scenery for Television-2

Constructing and Setting

By PETER BAX, Head of Television Design

PERHAPS I wasn't quite accurate when I said that Part I was a sketch of the progress of scenery as far as it concerns the designer. It is true that, up to date, the designer has been the person most concerned and that now we are to leave his office and go into the workshops. But we must be careful not to get the impression that the designer's job is over. By no means. He will come with us into the workshops and on to the studio floor later, and he will be visiting them continuously up to the time the final rehearsal is finished. Then he can, if he doesn't live too far away, rush home and see the results of his labours on his television screen. And, as often as not, he'll say to his wife: "Did you like my Baroque staircase in Act II?" and his wife will say: "Oh, yes, my dear, and I thought so-and-so came down it superbly—she is one of the few women who can walk down stairs like a queen." This, of course, is just as it should be. If the audience notices the staircase at the expense of the actress the designer has failed. His staircase is guilty of bad manners—it has called too much attention to itself. But we must hurry along with the plans (which have now had photostat copies made) and the models and the elevations over to the "Supply" side. Here serious and studious men look at them for a long time with deep interest. They are criticised, turned this way and that and compared one with another. This is not an artistic examination. It is pure business. Were you present you could hear such phrases as "About 200 man hours"; "£80, I should say"; "He can't have that door from stock, we'll have to make another." You will have gathered, of course, that estimates are being prepared. The Supply staff are assessing just what the designer's dreams mean to them in hard cash, hard work and unforgiving minutes. When they are satisfied, the plans are sent on their way, one set to the carpenters, one to the scenic artists and one to the painters—and possibly other sets to people who work in metal, paper or plaster. I'll just pause for a moment to explain the difference between the scenic artists and the painters. This often puzzles people. They are two quite different bodies of men. The scenic artists are those who paint the landscapes, the vistas of buildings, the fantasies of pantomime, ballet and musical comedy. The painters are those who paint walls and doors in the same way as a house painter. They also hang paper when required and do all sorts of other out-of-the-way jobs.

At the Alexandra Palace we have a great store full of scenery. This is card indexed and stacked in numbered racks. It sounds simple but, of course, one cannot arrange scenery as one can arrange office files or books. Scenery is all shapes and sizes and ranges from a simple "flat" to a cathedral door. A "flat," by the way, is, as its name implies, a flat unit like an artist's large canvas and made in much the same way. It has a wooden frame covered with canvas or plywood or both. Television flats vary in size a good deal, but an average flat is 10ft. or 12ft. high and 5ft. or 6ft. wide. They are

not much more than an inch thick, and so can be stored very easily. On the other hand, a scenic cathedral door has considerable thickness. It has steps and columns and all sorts of things and is a thorough nuisance. Rock pieces, staircases, fountains, grassy banks, telephone kiosks all have to be stored, and it will be easy to imagine that this part of the Alexandra Palace is a bizarre and perplexing place. (See Fig. 1.)

The men here work in shifts, and have become so adept that their memories often beat the card index. They have their own names for the larger pieces: generally the name of the production they were made for. Thus we have "Hansel and Gretel" flats which have done duty for scores of plays besides "Hansel and Gretel." We have the "Lightning" steps and the "Radiolympia" curtains. The designers also know this stock very well and it is very necessary that they should. It would be quite impossible to build entirely new scenery for every production. Television is expensive enough as it is. No, we have to use our scenery over and over again and think twice before we build anything new. No two shows are alike and it is rare indeed that one can be fitted out entirely from stock.

Stock

Usually our scenery is about 80 or 90 per cent. stock and the rest built new. Some of this new material will, in due course, become stock itself. Some of it will be broken up. We only break up when we have to and when we have carefully considered the probability of re-use and the available storage space. Even then the scenery that is broken up sometimes provides enough scrap to be worth using again, and in these days of timber licences you may be sure that the only wood that is thrown away is too short or too full of joints and nails to be any good to anybody. Incidentally, all our timber has to be bought under special licence from the Board of Trade.

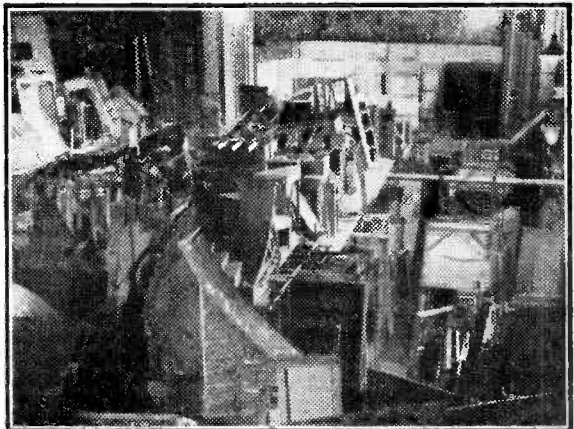

Fig. 1.—Part of the huge store of scenery props at A.P.

When the stock pieces have been selected and drawn from store they are set up together with any new pieces that may have been made. At this stage a scene looks anything but attractive. As many as a dozen different wallpapers and distemperings are in evidence. A wall from "Hamlet" will be cheek by jowl with a door from "No, No, Nannette." The window possibly came out of "The Importance of Being Earnest," and the fireplace from "Mary Rose." The built-in bookcase may be new, straight from the carpenters' shop, while the "garden backing" to go outside the window may still be in the process of being drawn out by the scenic artists.

Soon, however, the painters, with their brushes and their rolls of wallpaper, make a great change. In a few hours the queer mass of scenery becomes an elegant drawing-room ready for "The School for Scandal" or a fashion parade of evening gowns.



Fig. 2.—Mr. Woods, senior artist, sketching out scenery full size for painting in.

While this is going on let us walk over to the scene painting studio. The backing we spoke of just now is nailed to the "paint frame," an enormous easel 40ft. long which can be raised or lowered by winches. The scenic artists stand on a raised platform which is really a sort of first floor with a long slit in it through which the two paint frames slide up and down. Thus the artist is always at one level, while his canvas, which may be 15ft. or 16ft. high, can be put at any height he wants it. The backing looks just like a large square of stiff blue cloth, which indeed it is. It is actually canvas or hessian, and it has been "primed" with blue paint, which means that it has been coated all over one side with an even layer of the special paint that only scenic artists know how to use. It is blue because it is to be mostly sky. Had it been a stone wall backing it would have been probably primed in grey. This special paint is not at all easy to use. Scenic artists say it takes seven years practice to become really expert with it. It is made up as required by mixing powdered pigment with warm diluted size. When wet it is very much darker in tone than when dry. Therefore an onlooker who sees a scenic artist with a light blue design in one hand and a brush full of dark blue paint in the other need feel

no alarm. The dark blue paint will, if the artist knows his job, dry out to the exact tone of the design. This sounds difficult enough for a single colour. You can imagine what happens when a novice tries his hand at mixing a number of colours. It is related of a Royal Academician, who was rash enough to attempt it, that his scene, which looked strong and beautiful in the evening when wet, had faded into the faintest of pastels by the morning when it had dried. He had used the size colours as he would have used oil colours. He went back to oil colours from that moment!

The backing being dry, an artist is sketching out the design with charcoal. This may be tied on to the end of a long stick. The artist can see his work better if he is able to work several feet away. Some are so expert that they can control a piece of charcoal on the end of a 5ft. or 6ft. bamboo as easily as we can control a fountain pen. Others prefer not to work vertically at a frame but horizontally—then the backing is just laid down flat on the floor and the artist walks all over it, drawing as he goes. (See Fig. 2.)

Sometimes the backing is not painted at all but is enlarged from a photograph. The process is very like that familiar on a smaller scale to amateur photographers. The negative is enlarged in sections about 4ft. wide and 2yds. or 3yds. high. These are then mounted, just like wallpaper, on loose canvas or, for more permanent use, on a stiff frame of timber and plywood.

Near the scenic artists are the "caption artists." These are the men who specialise in lettering the titles, cast lists, notices and other writing you see on your television screen. Although not strictly concerned with scenery in general they are often called upon to put the name over a shop front or on a railway station. It is they who do the signboards, the notices and sometimes the documents that are always cropping up in productions.

The carpenters' shop looks, at first sight, much like any other carpenters' shop. It has the same sort of benches, circular and band saws, morticing machines, a lathe and so on. The work, however, is specialised. A scenic carpenter, like a sailor, must be ready for anything. He will be asked to make a submarine's periscope one day and Cleopatra's throne the next. He must make his work strong and light. It must bear the weight it is designed for without moving or even "feeling" insecure. No scenic carpenter must ever forget that however pretty a girl may be she weighs, on the average, a hundredweight, and a chorus of twenty of them weigh a ton. No girl can dance her best, and no actor can be quite convincing, if the steps or rostrums that support them are shaky.

(To be continued)

WORKSHOP CALCULATIONS TABLES AND FORMULÆ

Eighth Edition

F. J. CAMM

A handbook dealing with methods of calculation, solutions to workshop problems, and the rules and formulæ necessary in various workshop processes. It contains all the information a mechanic normally requires.

From all booksellers, 6/- net,
by post 6/6 from the publisher,

GEORGE NEWNES, LTD. (Book Dept.),
Tower House, Southampton Street, W.C.2.

Simple TV Attenuators

Circuits for Reducing Signal Strength in Areas where Overloading Occurs

By DAVID WAYNE

ATENUATOR pads, comprising three or more resistors connected together in a certain manner, are commonly used to reduce aerial signal input to television receivers in areas where the signal strength is very high. In fact, attenuation is usually indicated whenever the signal input exceeds 500 microvolts, though admittedly receivers vary in this respect, and those fitted with a sensitivity pre-set control in addition to the normal contrast control can operate satisfactorily in saturation areas without overloading the first R.F. stage of the receiver.

As a rough check, by mutual adjustment of sensitivity and contrast controls, it should be possible to reduce picture gain to the point where synchronising fails and the picture breaks up into pale patterns. If at the minimum setting of both controls the picture is still of reasonable contrast and synchronising well, then signal input is probably high enough to justify some degree of attenuation. Obvious symptoms of signal overloading are excessive contrast, producing a soot-and-whitewash picture (even with controls at minimum); sound on picture (visible as dark horizontal bars moving and fluctuating in sympathy with the sound modulation); picture on sound (audible as a pronounced "burr"—the 50 cycle frame repetition frequency); and sometimes instability and diagonal heterodyne lines superimposed on the picture.

An attenuator pad is simply a combination of resistors which can be inserted in the aerial feeder system, usually

resistance of the load is exactly equal to the internal resistance of the generator—that is, when the impedance of the input circuit of the receiver is the same as the centre impedance of the dipole—75 ohms. The aerial input transformer of all television receivers is designed to fulfil this condition. The feeder cable which connects aerial to set must also have the same impedance, and in practice coaxial cable is about 72 ohms, while the characteristic impedance of balanced twin feeder is slightly higher—about 80 ohms.

When, for any reason, matching is imperfect, not all of the signal energy from the aerial is absorbed by the receiver. There is a drop in signal input, due to the decreased efficiency of the system. Additionally, the unabsorbed energy is reflected back to the aerial, whence it returns again to the receiver, and so on. This continual reflection of R.F. energy, characteristic of balanced tuned feeders, but not untuned feeders as used in television, gives rise to standing waves on the feeder cable. If standing waves are present then the actual electrical length of the feeder cable is important, points of optimum matching (low impedance) occurring at intervals of a half-wavelength from the aerial.

The reflected energy present in a mismatched system produces undesirable effects in the picture. With long feeder lengths spurious images, ghosting and ringing of images can occur. Signal to noise ratio is decreased, line synchronising may deteriorate, instability may

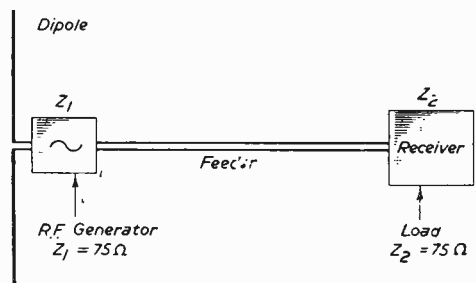

Fig. 1.—Diagrammatic representation of a dipole and receiver.

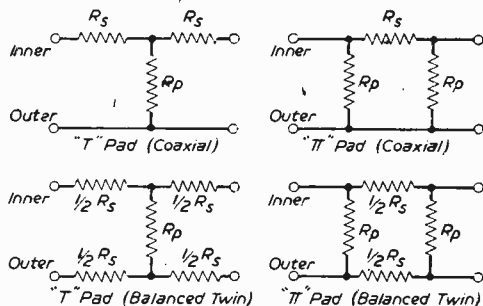

Fig. 2.—"T" and "π" pads for coaxial and twin feeders.

close to the set, and is designed to reduce the signal input to the receiver, while at the same time preserving the overall characteristic impedance of the aerial system. In other words, it has to match the aerial, the feeder and the input circuit of the set. For television purposes the matching impedance is usually about 75 ohms (varying between 72 and 80).

Matching

Matching is important, since at television frequencies the aerial dipole is a tuned circuit with a resonant frequency. It can be regarded as a generator supplying energy to a resistive load—the television receiver (Fig. 1). Maximum transference of energy occurs when the

occur with high contrast, and picture definition frequently suffers.

It is, therefore, important to fit an attenuator pad that will present an image impedance—in both input and output directions—which matches the characteristic impedance of the system as a whole.

Two Types

Attenuator pads in common use are of two types—"T" and the "π" (so called because the resistors are connected in the pattern suggested by those letters). They are slightly different for coaxial and twin feeders, giving altogether four different attenuator pads, so illustrated in Fig. 2.

The resistor values are derived from a set of simple formulæ.

$$\text{"}\pi\text{" } R_s = Z_0(a^2 - 1) \quad R_p = Z_0(a + 1) / (a - 1) \quad (2a)$$

$$\text{"}T\text{" } R_s = Z_0(a - 1) / (a + 1) \quad R_p = Z_0(a^2 - 1) \quad (2a)$$

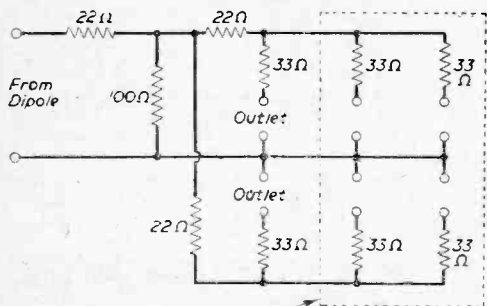

Optional Additional Outlets In Parallel. Matching Deteriorates As Number Of Outlets Above Two Is Increased.

Fig. 3.—Arrangement of attenuator for feeding more than one receiver.

where R_s is the series resistor, R_p the parallel resistor, and Z_0 the characteristic impedance of the feeder system (75 ohms). The symbol "a" denotes the attenuation ratio—that is, the ratio of input to output voltage required. To convert to decibels, multiply the logarithm of the ratio by 20. Decibels, however, are not required for the formulæ, but it is useful to know the db equivalent of any given ratio, since manufacturers' data is often expressed in dbs.

The following table gives resistor values for all four types of attenuator for the more commonly used ratios, and should be adequate for all practical purposes. Attenuators can be connected in series (or cascade) to obtain intermediate values, but it is important to remember that the ratios should be multiplied, not added. For instance, a 3 : 1 pad followed by a 4 : 1 would give an overall attenuation of 12 : 1.

The resistors should be fitted in a small junction box

ATTENUATOR VALUES

Ratio	Decibels	Resistor Values (75 ohm feeder)			
		" T "		" π "	
		R_s	R_p	R_s	R_p
2 : 1	6	25	100	56	225
3 : 1	9.5	38	56	100	150
4 : 1	12	45	40	140	125
5 : 1	14	50	32	180	113
10 : 1	20	62	16	371	92
20 : 1	26	68	7.5	749	83
50 : 1	34	72	3	1,875	78

Resistor values correct to nearest whole number (except for small values), but 10 per cent. tolerance is permissible. In general, resistors for "π" attenuator pads are easier to find since the values are higher, and consequently this type of pad is more commonly used.

close to the receiver, cutting the feeder and making the connections to terminal posts in the box. Alternatively, a good scheme is to solder the resistors and the feeder end wires to a tag panel screwed to the inside of the receiver cabinet. The braiding of coaxial cable should be unpicked and twisted to form a strong connecting lead.

When feeding more than one receiver from the same aerial, a matching pad in the form of a two-way split should be inserted (Fig. 3). This will prevent serious mismatching, and also reduce interaction between receivers to a minimum. If it is desired to feed only one receiver from any of a number of "extension aerial points" (one in each room, for example), then the outlets not in use should always be terminated by a loading resistance equal to the characteristic impedance of the system (75 ohms). In practice, a 75 ohm resistor can be conveniently connected across each outlet for permanent loading, the shunting effect across the point in use being negligible.

Careful attenuation in accordance with the above principles will ensure optimum receiver performance (always provided the aerial itself is efficient).

A.A. Asks Members to Suppress

THE following paragraph appears in the Automobile Association News No. 7:

"The opening of the new television transmitter at Sutton Coldfield has, naturally, meant a big increase in the number of viewers—and the number is growing week by week. The detrimental effect that passing car and motor-cycle engines produce on a television picture is well known. The A.A., therefore, asks members to help in eliminating interference by fitting suppressors as soon as possible. The cost is only a few shillings and the effect on the engine is almost negligible."

Welcomed by R.I.C.

The Radio Industry Council, representing the television manufacturers, welcomes this recommendation, which will benefit television viewers in London and the Midlands and farther north and west as other television stations open up. Its own recommendation, which it claims is between 85 and 95 per cent. effective, is to fit one 5,000 to 15,000 ohm resistor in the high tension lead between the ignition coil and the distributor—at a cost of between 1s. 6d. and 2s. It can be fitted in a few minutes at a garage or radio dealers, or by the motorist himself.

G.P.O. Action

The G.P.O. has suppressed its vehicles throughout the country and the R.I.C. states that suppression was adopted on this scale, it is understood, only after searching trials to ensure that there were no unforeseen effects on engine efficiency such as starting difficulties.

A Useful Vest-pocket Book.

WIRE and WIRE GAUGES

3/6, or 3/9 by post from

George Newnes, Ltd., Tower House, Southampton St., Strand, W.C.2

Sir Paul Dukes and Yoga

An Interesting Interview by the Marquis of Donegall

"PERHAPS you would now like to stand on your head on my terrace?"

"Well, I don't make a practice of it after a good lunch, but if you insist . . ."

The accommodating gentleman was Sir Paul Dukes, musician, secret agent and Yogi. Fascinated, as have been many other viewers by his television programmes explaining and illustrating the rudiments of Yoga, he had accepted to come and have a talk over luncheon at my place in Kensington.

Then, to the delight of the neighbours—and especially of Mr. Winston Churchill's personal police constable—he stood on his head, and stretched himself rigid with only neck and feet resting on the backs of two chairs. Viewers have seen him do this.

For a few days before our recent luncheon, I had been reading his "Secret Agent S.T.25." It is one of the best six shillings' worth. Sir Paul has also written "An Epic of the Gestapo" and "Come Hammer, Come Sickle."

"S.T.25" was, of course, himself and tells of his amazing adventures getting information back to M.I.5 from Petrograd and Moscow during the early days of the Bolshevik régime.

He made the highly dangerous crossing of the Russo-Finnish border three times and eventually, after months on end in Russia being hunted by the Secret Police, escaped via Latvia.

But we must let Sir Paul Dukes speak for himself into my wire-recorder, the microphone of which lay unobtrusively on the sitting-room table. Almost back to his Secret Agent days!

"I was a music student intending to make music my career. From the Conservatoire of St. Petersburg I was taken into the Imperial Opera by Albert Coates, its Chief Conductor. Coates was British, but Russian born.

"There I assisted in training his soloists for two years and I would probably have become a conductor had the first world war not broken out.

"Instead, I went to the Foreign Office and my chief, John Buchan—later Lord Tweedsmuir—sent me back to Russia after the Revolution had broken out. The outcome of that was that I was officially drafted into the Secret Service.

"I first became interested in Yoga while still a student in Russia, forty years ago.

"It was my good fortune, being interested in mystical subjects in general, to encounter certain 'Wise Men of the East,' who were adepts in this mystical lore and from them I learned the first principles of it.

"The Revolution upset my early studies very much and I lost contact with those teachers. But they had laid the foundation in a mysterious way which it is difficult to explain. I found ten years later—after that very disturbed period of war and revolution and as a correspondent of *The Times* in Eastern Europe—contacts, when I eventually went to America, with people who

were also able to continue to give me instruction in this art. Some were Indians; some were not.

"None of the instruction was complete, but one had the feeling of being provided with knowledge which had to be pieced together and translated into practical terms.

"Yoga is an enormous subject and all-embracing. It is a synthesis of the physical, mental and spiritual."

"Is Yoga a religion in itself?" I asked.

"No, it is not a religion in itself. It fits into all true religions but, in itself, it is not a theology or a dogma. It is a method—a method of mental and spiritual preparation and it is up to the pupils or students, to adopt or

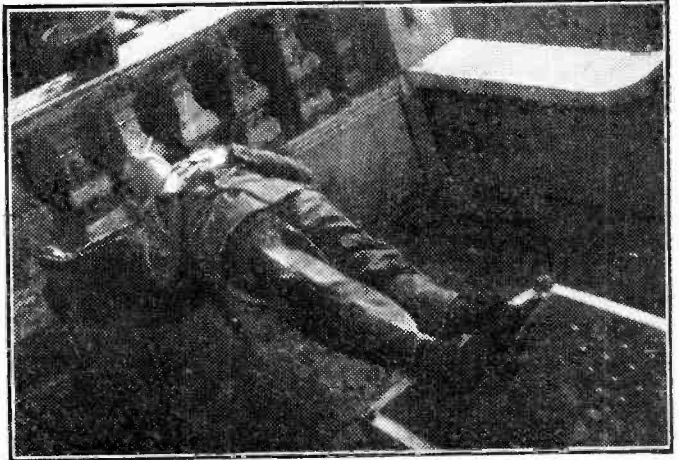

Sir Paul Dukes in one of his Yoga poses, his body supported on his neck and heels

not to adopt, whatever religion he or she feels best suited to."

Pursuing his theme of the complete synthesis of the physical, mental and spiritual, Sir Paul continued:—

The Physical

"Yoga begins with the physical because it regards the human body as the instrument provided for us by our creator with which we should work. We begin with the physical because our objective is to purify the bloodstream upon which all depends, and discipline and sensitize the nervous system. The results are, of course, improved health and certainly a great increase in enjoyment of ordinary life. We believe in our philosophy that we are intended to be happy and not unhappy, joyful rather than gloomy; that the good things of life every day should be good to us. In fact you get a totally different outlook on life through the result of this training and all those minor physical disabilities that beset mankind, such as nervous troubles, insomnia or indigestion—or even the common cold—begin to recede."

"Is there anything in Christian doctrine about Yoga?" I asked.

"There are fine descriptions of Yoga," said Sir Paul,

"in Christian doctrine. For instance, that the Kingdom of God is within us and is to be found by searching within us.

"Secondly, the Christian doctrine says that it is possible to unite with God—I and my Father are One." In fact, Christ's doctrine is Yoga, as we interpret it. We don't dwell too much on that. It just happens to be so. And so it is with the doctrine of many philosophies and with the wisdom which is inherent in all true religions. We never say that Yoga is a religion but it is a philosophy which fits into all true religion."

At this point I asked Sir Paul where Yoga originated.

He replied that nobody knows quite where it originated. "There is Chinese, Tibetan and Indian Yoga. They are all more or less the same. The earliest documents about it date some 600 to 800 years before Christ and the principles laid down guide the student to apply them to particular circumstances. For instance, circumstances in Tibet, India and China differ from those in London. Obviously you cannot stand on your head in public in London, but in any case that is only a minor practice of ours among many.

"Again, you can refer to the Christian doctrine, which says that devotion should be in private—'When you pray, pray in secret.'

"In fact, we don't go in for fantastic practices—just physical practices which purify the bloodstream and discipline the nerves. Such stunts as balancing on one finger or lying on a bed of nails—one a circus turn and the other a mistaken religious rite—play no part at all in Yoga."

Starting

"Well, how does one start?" I asked.

"You start in a very simple way and the exercises are graduated. We start with the lungs which are the nearest of all to life. That is because they give us breath. A human being can go for months without food and for several days without liquid; but you can only go for a few minutes, at most, without air. So breathing being the aspect of physical life which is closest to life itself, we, in Yoga, begin by training the breath. After breath training we come to training the alimentary track because it is what we put inside us, and how it is treated there, that dominates our well being. We do study a certain amount what we eat but there is no need to be fanatical about it. You don't have to be either a vegetarian or a food faddist of any kind. The idea is to study what happens to the food inside and see how we can get rid of the remnants quicker so that they pass out of the body more rapidly. Then we have certain physical exercises which are designed to train the nerves and all these exercises, or most of them, are very slow-motion because it is in slow-motion that you develop control. You know yourself that when you make any action in slow-motion you have to think of it every single instant—and there comes in the mental side—so that great concentration is developed.

"Later, we have special exercises to train the mind—sitting absolutely still, for instance. That is why we learn certain postures, all of them harmonious and symmetrical. They are designed to exert certain pressure on nerve centres and glands and stimulate them."

In his book, "An Epic of the Gestapo," Sir Paul visited Dresden. He went to what the Nazis described as the German Museum of Hygiene. The Museum was, of course, designed to show how superior the Germans were to every other race in the world. There were various working models and at one of them the visitor was invited to blow into a tube and test the capacity of his lungs.

There was a Brown Shirt guide—a burly fellow—who blew nearly 3½ litres. This he proceeded to do in front of an admiring crowd, the best of whom had only managed to blow some 2½ litres. Sir Paul had already had one trial blow before they arrived and the Museum attendant said to the crowd: "You ought to see what this gentleman can do!"

So Dukes took the spout and started to blow: 1, 2, 3 litres. When he reached 3 litres, the Brown Shirt guide began to look somewhat discomfited. But when he reached 3½ litres there were muffled exclamations from the crowd. But he still went on to 4, 4.2, 4.3—finally, 4½.

Long before this the Brown Shirt had taken away his flock of admiring Nazis. But the Museum attendant said: "I have never seen such a thing in my life."

Whether he lost his job as a result of making a complete fool of the Nazi guide is not related.

Sir Paul continued: "You asked me how long one should devote per day. That is a difficult question to answer. The ideal is to pass through a period of training which shall effect in you a process of regeneration—rebirth. That again, is Christian doctrine, in the sense 'We must be born again.'

"Well, Yoga interprets that and you are in fact transformed and it lasts you for the rest of your life. In a sense, you put the clock back and when you have achieved this rebirth you do not have to think nearly so much about taking a certain amount of the physical exercises every day."

"But surely you have to keep the thing going?" I asked.

"Within reason," answered Sir Paul. "But the idea is to get yourself into a certain condition and then operate as such. Then, of course, you have to maintain that condition as you do with a motor-car. You send your car to the garage to have a new piston put in. Thus, so to speak, putting the clock back in so far as the life of your motor-car is concerned. You can do the self-same thing with yourself. With a certain amount of maintenance you can reach a condition where you can very greatly extend the span of life. We are all mortal but Yogi do not believe in retiring at 60. On the contrary, we believe that we mature at 50 and believe in having a good time for the rest of our lives."

For Children

I asked Sir Paul about Yoga for the children and he said that Yoga can only be appreciated when you are grown up and have been through the mill, because it is a training for life—for how to live—without suffering the setbacks and disappointments that most people have. But he did say that it is probable that by putting children through the training they would be better protected against the usual ailments of childhood through being thoroughly healthy. On the whole, it would seem that 30 is the best time to take up Yoga as it is better if you know something about life and its difficulties before you start.

This more or less finished our talk except for my getting Sir Paul to write down for me the various branches of Yoga.

"Anyway," concluded Sir Paul, "we maintain that all these things arrive at the same point in their different ways, as suited to the particular individual."

I would have been quite enough impressed by this time. But at this point, Sir Paul Dukes swallowed his glass of port and for what happened next, I refer you back to the opening sentence of this article. What a man!

Servicing Television Receivers—4

How to Locate Faults and Cure them in Commercial and Home-made Equipment

By W. J. DELANEY (G2FMY)

AS most readers know the received video signal consists of picture impulses and synchronising impulses, all of these usually being present at the video stage. It is, therefore, necessary at this point to provide some means of separating these two types of impulse. The majority of time-bases are designed to be adjusted to run near this correct speed, but obviously for perfect reception they must keep in step with those at the transmitting end, and consequently the synchronising pulses are devised to fulfil that purpose. Without going into too much technical detail the illustration Fig. 1, shows the form of a pulse—the dip in the upper line, and the sloping lines indicate the rising current of a pulse

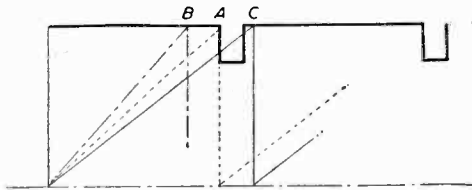

Fig. 1.—Time-base firing point and the effect of different sync pulses.

due to the charging or discharging of a condenser. If the time-base is adjusted to run to provide the drop as shown here, then a sync pulse arriving as indicated by the chain line B will fire the base too soon. Similarly, if the pulse arrives as shown by the solid line C, the base will have fired itself before the pulse arrives and thus the sync pulse will be non-effective. Actually, the pulse should arrive just before the base is set to fire and it will thus be operated at the correct point approximately as indicated by the broken line A.

Some time-bases utilise gas discharge tubes in which current builds up in a condenser and at a certain value the tube discharges it, whilst in others a form of oscillator is used, and the valve is set into oscillation which results in a condenser becoming charged until the grid of the valve becomes choked or blocked, at which point the valve ceases oscillation (the blocking oscillator). Discharge of the condenser takes place through a resistor. Whatever form the time-base oscillator takes, the main point to be emphasised is that only the appropriate sync pulse should be applied to it—the frame pulse to the frame time-base and the line pulse to the line time-base, and each of these pulses should be completely free from picture impulses. This is where the usual troubles of faulty synchronisation arise—incomplete elimination of the picture pulses, or unsatisfactory discrimination between the two sync pulses.

Sync Separator

A very common form of separator is a pentode valve acting as a limiter, that is, with low anode voltage and usually a critical screen voltage. Now when sync separation is correct and each base receives only its correct pulse, the picture will be properly interlaced and perfectly steady even with some degree of interference—pro-

vided the design is satisfactory. Thus, a picture which breaks up horizontally at odd moments, or in which the horizontal black bar separating adjacent frames rises and falls across the screen, or where the vertical black bar jumps into and out of the picture indicates poor sync working. If the set is switched on and the picture runs round vertically and no adjustment of the frame time-base control will hold it steady, then there is an absence of frame pulse. If the horizontal black bar is absent but the picture appears to be broken up diagonally and travelling across the screen in a series of diagonal lines or broken images, and the line hold control has no effect, then line sync pulses are absent. This should give some indication as to where to look for the trouble. Some simple sets have an integrating and differentiating circuit—a series of resistors and condensers to separate the pulses, and it will no doubt be found that one or other of these is open circuited. If the sync separator is a pentode with line and frame pulses taken from the screen and anode (a fairly common arrangement), then a lead may have come away from the valve-pin connection, or the feed condenser may be open circuited to the appropriate base. If a diode or single valve is used for the sync separator this may be removed to see if it has any effect on the results. If there is no change, then it will prove that this is the trouble and the necessary circuit check may be made. As there is such a wide range of circuits for this particular purpose it is impossible to give all the tests but location of which pulse is missing will reduce the amount of checking to be done.

Picture Distortion

Unfortunately there are one or two faults in sync separation which can cause picture distortion, that is, they permit the raster to be held quite steady, but produce a distorted picture shape. The most common of these is that which produces a picture with a curved top, and this is due to the line circuits not holding steady during the frame pulse. Similarly, fly-back pulses from the

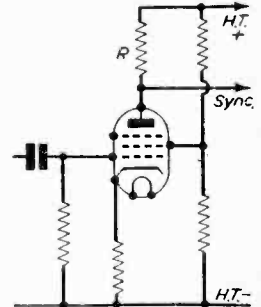

Fig. 2.—A pentode limiter such as is found in many television receivers.

line base may get into the frame circuits and affect their function, so that it will be seen that the separator can give rise to a very wide range of troubles.

Time-bases

From various remarks in the preceding notes it will be seen that the two time-bases must be adjusted to run near

their correct speed, and most receivers have a control for this purpose. It is variously referred to as "line (or frame) hold" or "line (or frame) frequency." When adjusting this on a received signal it should have a fairly critical setting. At one end of its travel the picture should be broken up either in the vertical or horizontal direction (according to which control is being operated), and as it is rotated there should come a point where the picture

suddenly jumps into synchronisation, that is, the picture locks. Further rotation of the control should be possible over a few degrees and then the picture should break up again as it did at the first setting. If this adjustment can be carried out on both time bases it will indicate that they are operating satisfactorily, and any fault which produces failure to hold or break-up of the picture must be due to the earlier circuits, namely the synchronising separator.

Is It Worth Looking Into?

A Non-technical Reader Looks at the Position of the Practical Man and the Programme

By I.O.M.

A COMMERCIAL artist was recently explaining to me exactly why a certain Royal Academy picture was good, in his opinion. He was detailed and enthusiastic. I asked him what the picture was called and what it depicted. He looked at me for a moment and I felt I had "let the side down," by asking a foolish question. Then I realised that he had to *think* what the picture was about. He was so absorbed in the technique of the painter that the subject scarcely mattered.

I immediately thought of the practical television enthusiast who cares little or nothing about the B.B.C. programme but who can detect a slight transmission fault in a split second. I hope he is not a typical, practical man, for the enthusiastic constructor and experimenter has a big responsibility to the lay public at this stage in the growth of television—a responsibility which he can unwittingly ignore just because of his technical interests. He is closer to television than anyone outside the B.B.C., with the possible exception of the television manufacturers. He should, therefore, take a carefully balanced view not merely of "the picture," but also of the programme, because he can influence the public attitude to the programme and because what the public thinks will sooner or later influence the programme itself.

As a practical television enthusiast as distinct from a mere viewer you should remember, too, that further technical advances by the B.B.C. will not be possible without public funds. Unless the public will endorse further expenditure by giving the B.B.C. their backing or until they do—you cannot look forward to higher definition, larger screens, colour or stereoscopy. So it is in your practical interest to do your utmost to ensure an enthusiastic viewing public. You can best do this by talking about the programme, not always about the set. And by talking in the right way! In fact, every TV experimenter should be a self-appointed and unpaid member of the B.B.C. Public Relations Staff. This may appear to silence your criticism and make you fundamentally dishonest—but remember that the good public relations official, if he has a good, honest organisation to publicise, can afford to be both honest and critical. He is doing the greatest service when he admits weakness if such exists, but at the same time reveals the reason for that weakness and invites suggestions for improvement. That is the kind of PRO you can be for television in this country to-day!

So far as the B.B.C. programmes from Alexandra Palace are concerned, the honeymoon is over! Although there are still enough homes without sets in both the London and Midlands TV areas, to keep manufacturers and home constructors busy for years, already the glamour is gone—the first fine careless rapture! It is no

longer even a social distinction to own a set. Set owners (at least most of them), have now been viewers long enough to be selective in their viewing. They don't just look at everything and marvel at it and tell the boys about it in the train next day! They pick their programmes—and here is the significant fact at this point in time, only a few months after the commencement of the second transmitter—viewers are no longer silent about what they *don't* like. They criticise, they frequently grumble, they run the B.B.C. down. All of which they are quite entitled to do. But their criticism is inclined to be as unreasonable as their recent unstinted praise. It is a sort of reaction to the first flush! If it grows too strong it will retard the spread of television, retard its possible technical development and, therefore, limit its future pleasure for you—the technical man.

Sense of Proportion

So, talk to the armchair critics! Try to restore their sense of proportion. Don't forget that those who do not yet own sets, either because they cannot afford them or cannot get them, will be only too delighted to encourage disgruntled "nattering." This is probably a simple case of sour grapes, but it can all mount up to very bad propaganda indeed for TV.

Yet another anti-television element, is provided not unnaturally, and perhaps even without deliberate malice, by the cinema industry and sports promoters. The former see in it a direct competitor to the screen—which indeed it is—and if the cinema industry succeeds in getting TV programmes on to the full-size screens of cinemas then the barrage of propaganda pooh-poohing the tiny home picture, will openly increase to fury. Sports promoters will obviously go on suggesting that there is nothing like the real thing. "You've got to go to the event," they will say "to get the thrill." They will even argue in self-preservation that it is better to go to a minor league match in the flesh than view the Cup Final at home—better to attend a local point-to-point than watch the National on TV—when we can!

All this is dangerous to the immediate future of television. The true assessment of the worth of present programmes is somewhere between the idolatry of the new viewer and the disillusion of the jaded viewer. It is not so good as the maker of the commercial receiver would have you believe and not half so bad as competitive forms of entertainment will persuade you. It is a wonderful home entertainment, perhaps the finest ever, and apart from the capital cost of the set it is a *cheap* entertainment. The licence for a whole year, including radio, is equivalent to the price of only about half a dozen visits to the cinema for two—and usually more than two at a time watch TV.

Mullard Television Valves and Tubes

*By far the best in
Everybody's View!*

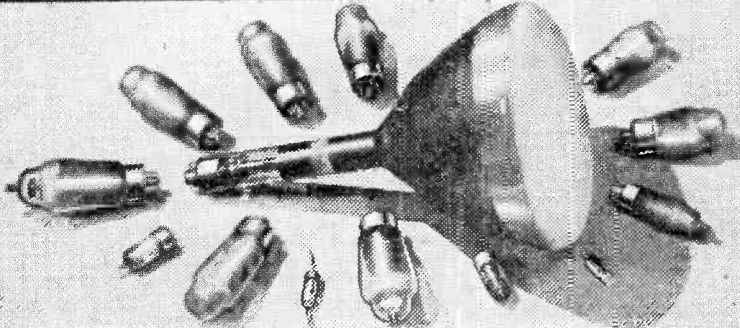

Mullard Electronic Products Ltd. Century House, Shaftesbury Avenue, W.C.2

Are you building the 'VIEW MASTER' — the Television Set you can build at home from standard parts?

Here for the first time is a Constructor Envelope which by means of 8 full size drawings gives the clearest and most detailed stage-by-stage instructions for building a Television Receiver. Failure is impossible. The accompanying 32-page booklet not only explains how the set works and gives a complete breakdown of the circuit, but also includes a most lucid explanation of Television.

You can build the "View Master" with complete confidence, knowing that it has been designed by W. I. Flack, Fellow of the Television Society, and sponsored by eight of the leading British component makers. Two models are available: Model A for London area, Model B for Sutton Coldfield area.

Constructor Envelopes price 5/- on sale at your local Wireless Shops or direct (5/6 post free) from "View Master", 10, Norfolk Street, London, W.C.2.



- Uses 12" or 9" C.R. Tube.
- Console or Table Model.
- 12 Valves only.
- Magnetic Focussing.
- Metal Rectification throughout.
- Automatic Interference Suppression.
- Easily aligned without instruments.

PREMIER Long Range TELEVISOR KITS

FOR LONDON AND BIRMINGHAM

USING 9" OR 12" MAGNETIC C.R. TUBES.

£19.19.0 including all parts, valves and loud-speaker, but excluding C.R. TUBE (Carriage, etc., 15/-)

The Vision Receiver, 4 R.F. stages (6F54s), Diode Detector and Noise Limiter (6H6) Video valve (6F54). Complete Kit with valves, **£3/16/0**. Carriage 2/6.

The Sound Receiver, 3 R.F. stages (6SH7s), Double Diode Triode (6Q7), which acts as Detector and L.F. Amplifier, Noise Limiter (EA50), output valve (6V6). Complete Kit with valves, **£3/1/0**. Carriage 2/6.

The Time Bases, blocking oscillators on Line (6SH7 and 807), and Frame (VR137 and 6V6). E.H.T. from Line Output Transformer, 10in. P.M. Speaker, Sync. separators 6H6 and 6V6. Complete Kit with valves, **£8/5/6**. Carriage 5/-.

The Power Supply, double wound transformer isolating the receiver from the mains. Rectifier 5U4G. Complete Kit with valves, **£4/16/6**. Carriage 5/-.

CONSTRUCTION BOOK 3/-

The following Sensitivity figures prove that the Premier Televisor Kits are capable of reception at greater distances than any other Standard Commercial Kit or Receiver whether T.R.F. or Superhet.

VISION RECEIVER. Sensitivity: 25 μ v for 15v. peak to peak measured at the Anode of the Video Valve. Sound Rejection: Better than 40 db. Adjacent Sound Rejection: Midland Model. Better than 50 db.

SOUND RECEIVER. Sensitivity: 20 μ v. Vision Rejection: Better than 50 db.

New Summer List now ready, 6d.

USING VCR97 C.R. TUBE. **£17.17.0.** (Carriage etc., 15/-)

Five Easy to Assemble Kits are supplied:

Vision Receiver with valves, carriage 2/6	..	£3/13/6
Sound Receiver with valves, carriage 2/6	..	£2/14/6
Time Base, with valves, carriage 2/6	..	£2/7/6
Power Supply Unit with valves, carriage 5/-	..	£6/3/0
Tube Assembly, carriage and packing 2/6	..	£2/18/6

This unit includes the VCR97 Tube, Tube Fittings and socket and a 6 in. PM Moving Coil Speaker with closed field for Television.

The Instruction Book costs 2/6, but is credited if a kit for the complete Televisor is purchased.

Any of these Kits may be purchased separately; in fact, any single part can be supplied. A complete priced list of all parts will be found in the Instruction Book.

20 Valves are used, the coils are all wound and every part is tested. All you need to build a complete Television Receiver are a screwdriver, a pair of pliers, a soldering iron and the ability to read a theoretical diagram.

WORKING MODELS CAN BE SEEN DURING TRANSMITTING HOURS AT OUR FLEET STREET AND EDGWARE ROAD BRANCHES.

PREMIER RADIO CO.

MORRIS & CO. (RADIO) LTD.

POST ORDERS TO 167, LOWER CLAPTON RD., E.5.
Phone: Amherst 4723.

CALLERS TO 152/3, FLEET ST., E.C.4. Central 2833.

207, EDGWARE RD., W.2. Ambassador 4033.

This branch is open until 6 p.m. on Saturdays.

PORTABLE ELECTROSTATIC VOLTMETER

≡ E I C ≡

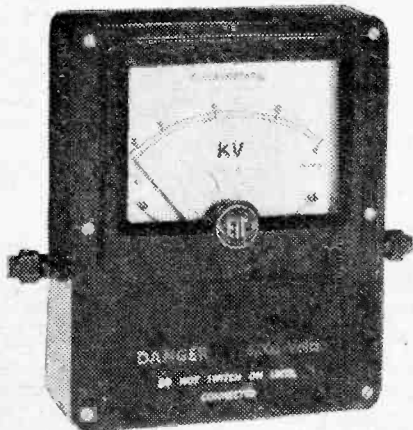

The Ideal Instrument for the Measurement of the EHT Supply to the Cathode Ray Tube

ELECTRICAL INSTRUMENT Co.

Boswell-Square, HILLINGTON, GLASGOW, S.W.2

For the best signal in "difficult" locations,

USE



PANDA Towers and Arrays. Our Standard 46ft. self-supporting steel lattice mast will put your array well over 50ft. high, and only a 4ft. base is required. Delivered from stock complete with foundation bolts and all instructions for assembly on the spot.

£32 10. 0:

ex warehouse.

No unsightly guy wires! Designed and built by skilled, experienced engineers. Special arrays also available to give best picture in "fringe areas."

PANDA RADIO CO.

58, SCHOOL LANE, ROCHDALE

The Phenomenon of Fluorescence

Some Facts About the Active Material of Television Screens—Its Nature and Properties

IT is fortunate that there are certain materials which emit light-impulses under the impact of electrons. For if such were not the case the cathode-ray television tube would be an impossibility.

Luminous materials and the various facts of "cold light" have interested scientific people for a very long time. Yet, strangely enough, it is only within comparatively recent times, and particularly as a result of the coming of television and the introduction of fluorescent tubes generally that the whole field of cold light production has been scientifically explored.

Even now there are still some mystifying facts about this cold light business which are not clearly understood, particularly in relation to the technical manufacture of the necessary "active" or light-producing materials.

We have, however for the first time in history, a

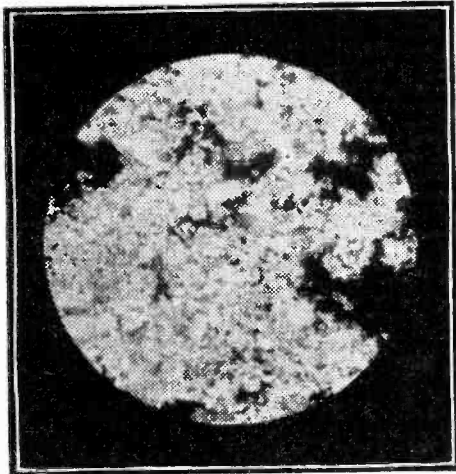

"Active Material" under the microscope. A highly-magnified aspect of a 100 per cent. pure zinc silicate prior to its "activation" for television work.

fairly good idea of the cause of the cold light, of the characteristic luminescence of the television screen and of other allied phenomena.

Briefly, in the case of the television receiver screen, it is simply a case of electron impact, an instance of electron being hurled against electron.

The generally accepted atomic view of matter is that each atom comprises a central, relatively heavy nucleus which is composed of a close assembly of protons and other particles, and that, revolving around this normally stable central nucleus are numbers of electrons, the precise number of electrons determining the chemical nature of the atom. The electrons are, of course, negatively charged, and the sum total of negative electron charges exactly balances the positive charges of the protons in the central nucleus of the atom. Hence, as a complete entity, the atom is always a perfectly neutral-body.

Electron Displacement

Exactly why some materials give rise to fluorescence and others do not do so we have, as yet, no precise knowledge. But it is certain that when a light ray of high energy content or, alternatively, a stream of high-speed electrons falls upon a fluorescent substance, one or more of the planetary electrons in each atom of the fluorescent body is temporarily knocked out of its appointed orbit or circular path round its central nucleus.

When this sort of thing happens, two subsequent events can occur. In the first place, the displaced planetary electron can return to its former orbit immediately the exciting ray or electron stream has ceased. This is *fluorescence*. As the displaced electron springs back to its proper place in the atom assembly it radiates the extra energy which it received from the electron-stream impact as a flash or a pulse of light.

With some materials, however, this swing-back of the displaced planetary electron does not take place immediately. It may be delayed for seconds, for days, and even weeks and months. In this event, the material remains luminous *after* the electron stream or other exciting cause has ceased, the luminosity being due to the gradual return of the planetary electrons to their proper positions in the atom. Such a phenomenon is known as *phosphorescence*, and it must be very clearly distinguished from fluorescence, which latter, as we have already seen, denotes the cessation of light-generation immediately after the exciting cause has departed.

A merely phosphorescent material would never function in a television cathode-ray screen, for the simple reason that the light emission of the active material would persist after the exciting electron stream had passed on, so that hopeless confusion and blurring of the picture would occur. Indeed, in the preparation of these active materials for television purposes the greatest care has to be taken to ensure that the materials do not pick up traces of phosphorescent substances which would completely ruin the sensitive fluorescence of the active material.

The actual strength or intensity of the light emitted by the active material of a television screen depends partly on the speed of the electrons in the cathode-ray

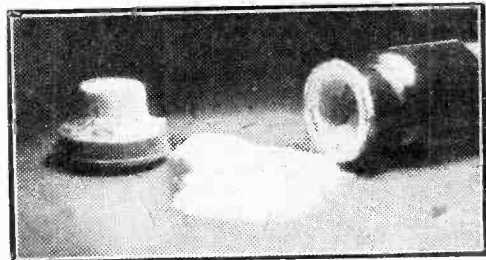

Fluorescent material radiating "cold light" under ultra-violet ray activation. The picture was taken by "cold light" of the material alone.

pencil or stream. But the light-intensity is also governed by the chemical nature of the active material, as is also—and to a very great extent—the colour of the emitted light.

Distorting Reflector

A fluorescent material acts, in a way, as a sort of distorting reflector. Its atoms absorb energy and then return it in a different guise. Such an atom, for example, will absorb energy of high frequency and emit it at a lower frequency. Thus, short wavelengths of light will always be transformed into longer wavelengths. Hence, the colour of the light emitted by a fluorescent material will always be nearer the red end of the spectrum than the colour of exciting light. There is always an energy-loss in this fluorescing mechanism, and, because of this, the light-energy emitted by a fluorescing material is always less in amount than the light or electronic energy absorbed by the material.

One of the earliest fluorescing materials used for X-ray and cathode-ray tubes, was magnesium platinumocyanide, which gave a vivid greenish fluorescence. The ever-increasing price of platinum and its salts, together with the complete unsuitability of a lurid green fluorescence for television work drove this compound out of the market.

Natural zinc silicate gave a less objectionable greenish glow under electron influence, whilst in the case of calcium tungstate (an early competitor of magnesium platinumocyanide) the fluorescent glow was blue in colour.

Potassium bichromate was found to give a red glow, as also does zinc phosphate. Cadmium tungstate, on the other hand, emits a light blue fluorescence under electronic excitation, whilst the well-known zinc sulphide (a constituent of many luminous paints) produces a pale green glow.

The problem of television research has always been to produce the picture on the receiving screen if not actually in natural colours, at least in a normal "photographic" black and white neutral colouration.

In modern times a number of fluorescing materials have been devised which, in certain admixtures, are able to produce "white" or "daylight" glows, as witness, for example, the now well-known luminescent gas-discharge tubular electric lamps. Some of these active material mixtures can be applied to television screen usage, the principal materials of this type being zinc ortho silicate, zinc beryllium silicate, calcium tungstate, magnesium tungstate, cadmium borate, cadmium chlorophosphate and various uranium salts. For television work, a mixture of zinc beryllium silicate and magnesium tungstate is popular, since it gives a pleasant "daylight" glow with just a touch of warmth. The mixture fluoresces brightly, and, provided that its constituents are carefully prepared, it is quite free from the objectionable "after-glow," which is actually a sort of residual phosphorescence, in consequence of which the material continues to glow for a second or two after the exciting rays have ceased.

The commercial manufacture of active materials of various types for television screen use and for other purposes is, in reality, a very difficult task. It is a job which requires the very greatest degree of chemical precision, the difficulty being not so much in obtaining satisfactory results, but rather in matching exactly the various manufactured batches of material in regard to intensity and colour of fluorescent glow. Partly for this reason, it may be noticed that the image colouration of different television screens varies considerably, one screen giving a much "colder" image than another.

The First Step

The first step in the manufacture of these active materials is to prepare the required substance in a condition of very high chemical purity. This necessitates an unusually high standard of working, the greatest stress having, throughout the process, to be laid on a meticulous cleanliness of chemical processing. There are certain common impurities which must not be allowed to be picked up by the active material under manufacture. Chief among these impurities are compounds of iron, lead and chromium, because, even in very minute amounts, they seem to inhibit the development of fluorescence in the prepared substance. Iron, for example, if it is present to a greater extent than about five parts per million in the fluorescent substance, reduces its luminosity of glow very considerably. In larger proportions, indeed, it may actually extinguish the glow altogether.

Because of the necessity for such a high degree of



At the bottom of this beaker, below the water level, is a highly purified copper hydroxide which is utilised in the preparation of the copper "activator" for fluorescent and luminescent materials. There is sufficient material here to activate many thousands of TV screens.

chemical purity, the active material is prepared in an all-glass or, better still, in an all-silica apparatus, the process usually being run on the laboratory-bench scale, since on any large manufacturing scale it becomes wholly impossible to guard against trace contamination of the material.

Sometimes the luminosity of the material or the colour of its glow is developed or modified by the addition of extremely minute traces of other substances which form a solid solution within the minute crystals of the material. These trace substances are called *phosphorogens*. Their main effect, however, is to increase the phosphorescence, as distinct from the fluorescence, of the active material. Hence, for television screen purposes they

are either not used at all or else in almost inconceivably small amounts, so that they act merely as colour-modifiers or as glow-intensifiers of the fluorescent material.

Phosphorogens can be of varied composition. Mostly, they comprise salts of manganese and copper, but at times traces of the very rare metals (samarium, terbium, europium) are used to heighten the intensity of the luminosity. These phosphorogen "activators" are added to the active material in proportions of the order of one part in 20,000 of the material, and sometimes in even smaller amounts than this.

Much of this preparative work is secret in the matter of its details, particularly as regards the proportion of activator added to the bulk material. If too little or too much of the activator is incorporated, the result is the same—a decided diminution of brilliance of the glowing material under electronic excitation. Too much activator, particularly, may start up an after-glow which, desirable as it is in the case of material required for luminous paints, is capable of ruining a fluorescent material for television screens.

Heat-treatment Necessary

The prepared material, with or without "activator" additions, is finally subjected to a form of heat-treatment, being packed into silica crucibles for this purpose and heated at a high temperature in a refractory-lined miniature muffle furnace specially designed to exclude traces of the "poison metals" being picked up from the furnace walls or lining.

This calcining process is a very important one, and it needs considerable experience to carry it out. The quality of the active material product and its freedom from undesirable features depends on the precise temperature-control of the furnace, the duration of the heating, and the cooling rate of the calcined material. For it is only by careful control of these factors that the material is given its most effective and essential micro-crystalline characteristics and particle-size.

In some cases, an inert gas is circulated through the furnace to prevent the oxidation of the material during heating. Temperatures required vary from about 800 deg. C. to 1,100 deg. C., and heating times are normally between 15 minutes and 1½ hours—all depending on the chemical nature and type of material under

heat-treatment. Usually, quick cooling of the material is desirable, because slow cooling tends to modify the crystalline structure and to reduce the intensity of its glow.

On being taken out of the furnace, the material appears in the form of a hard, porous cake. This has to be reduced to powder, not by any severe grinding process, because this would alter the crystalline structure of the substance and thus reduce its luminosity. A process of controlled crushing or disintegration is applied to the cake material, and the resulting powder is carefully sieved through graded screens.

Influence of Particle-size

Generally speaking, the coarser the particle-size of the material (within limits), the more intense is its glow. Obviously, however, there is a very decided limit to the particle-size of active material which can go into the making of a television receiving screen, for enhanced particle-size makes for coarseness of screen texture and, consequently, for reduction of definition.

Usually, these active materials are turned out in particle-sizes ranging from 60 to 150 microns.

These active powders are not very stable when freshly made, but their stability increases with storage under the right conditions. Particularly are some of them highly sensitive to moisture, which is rapidly absorbed by them and which seems to be able to destroy their luminosity. After manufacture and final testing, therefore, they are immediately packed into tightly corked amber glass bottles, which are themselves closely wrapped in moisture-proof transparent material.

Attachment of the active material to the glass of the television screen is quite another problem, since the material must be coated on to the glass in a perfectly smooth and uniform layer, the constituent particles being firmly bonded in position.

Many binding materials have been used for such purposes. The modern solution of the problem is to use a synthetic resin of a transparent type, such as poly-vinyl acetate. This is dissolved in a suitable alcoholic solvent and the active material is worked into the solution after the latter has acquired the correct viscosity. Coating by spraying is then a relatively simple task, and one by which a compacted, uniform film of bonded active material is able to be built up under very accurate control.

Interference

A NEW angle on interference recently appeared in an American magazine, "Electrical World," and the following notes will no doubt be of interest to readers who are having difficulty in locating certain forms of interference.

"The old-type lamp using straight tungsten wire, folded several times over supports at the base and top, is not only an inefficient light source but a cause of television interference. Such lamps have extremely long life and many are still used in some hallways, bathrooms and other places where the amount of light is not of prime importance. Such lamps emit an RF signal usually around 20 to 27 Mc/s., modulated several hundred per cent. at power-line frequency. This radiation is rich in harmonics which fall into one or more of the low-band television channels.

"The effect on the picture is approximately the same as that of diathermy, except for duration. Some of these offending lamps may be left on hours at a time, which would indicate that short-use diathermy is not

involved. The maximum area affected by old-type tungsten lamps is approximately three blocks in radius from the offending source. Sometimes the interference appears as two or more narrow bands. Tests with several of these old lamps show the signal is very broad—about 2 Mc/s. at the fundamental frequency of approximately 25 Mc/s.

"The cause of interference appears to be due to their acting as dynatron oscillators at the points inside the bulb where the tungsten filament from the base terminals approach the tip of the bulb. At these points a slight carbon deposit develops on the wire and naturally a difference of potential exists between these two points. This might not occur if the lamps were completely evacuated. In fact, it appears that only those lamps with a small remaining amount of air or gas impurities oscillate to cause television interference.

"Location of such interference is, in most cases, very difficult at present due to the irregular operating time of the offending lamps. If the customer's aerial can be easily rotated, it may be turned to determine the direction of the offending source, and thus help locate such lamps."

THIS home-constructor receiver was first published in our companion paper, *Practical Wireless*, at the end of last year, and has proved very successful. All copies are now out of print, and many requests have been received for a reprint of the details, so in order to meet this demand, as well as to introduce the receiver to the vast new public who are now interested in home television receiver construction, we are giving the full details, and a full-size blueprint will be available in the near future.

For those who did not see this receiver at Radiolympia, the following details are given concerning it. It is in two parts, a mains unit containing the sound output stage and loudspeaker, together with the standard mains transformer and the E.H.T. unit. The other part contains, on one chassis measuring 14in. square and 2½in. deep, the vision and sound receivers, the sync. separator and the time bases, with the tube and its associated equipment. Focusing is by permanent magnet, and the deflection coils are choke coupled to a hard-valve time base, the reliable and efficient Haynes' components being used for this section. The sync. separator is a three-valve arrangement and the interlace and locking are solid.

The vision receiver is of the straight type, with 4 R.F. stages, incorporating heavily-damped 1:1 transformers. A double diode provides rectification and noise limiting. The sound receiver has two R.F. stages which are not common to the vision section, and again a double-diode is used for rectification and interference limiting. Each section of the two receivers is built up separately, separating screens and tag-boards being used in a form of unit construction. These units are dropped into place and wired to the valveholders to complete the circuits. To avoid the use of chokes, etc., the heater and H.T. circuits are split, and the wiring run in different directions.

For the London area, the receiver utilises the upper sideband for vision reception. The Birmingham station is for lower sideband, and therefore uses slightly different vision circuits.

It should be noted that the receiver may be mounted in either a table or console cabinet. The two chassis side by side, will call for a cabinet about 26in. long and with an overall depth of 16 or 18in. Alternatively, a console may be used with the speaker mounted in the lower section and the vision section above it. The field from the special loudspeaker is small enough to enable the two units to work side by side and touching. The general construc-

Building the P.W. TELEVISION

An 18-valve Home Constructor Design for

tional details apply to both London and Midland models.

Circuit Details

The receiver has been designed to provide ease of construction and ease of operation, and the main details will be seen in the circuits below and on the next page. Below is the vision, sound and mains sections, whilst on page 170 will be found the sync. separator and hard-valve

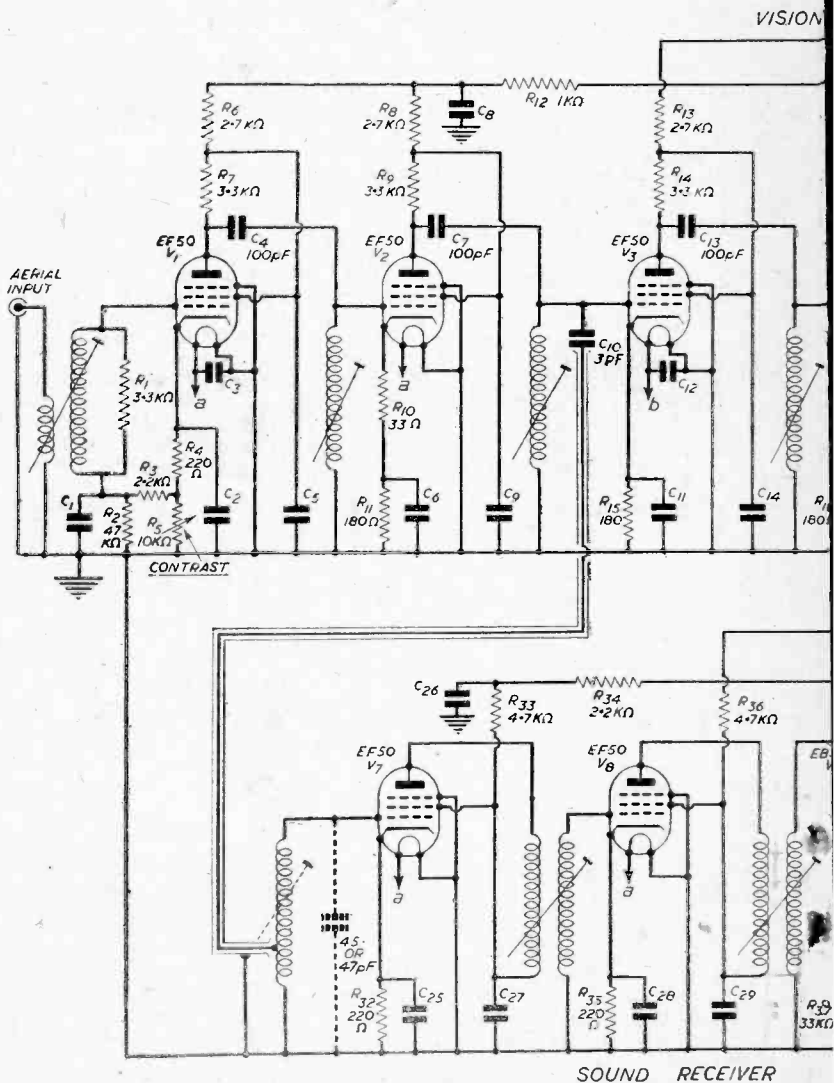

Fig. 1.—Theoretical circuit of the vision, sound and power units of receiver.

ON RECEIVER

High-quality Results on 9 or 12in. Tubes

time-bases. An examination of the vision circuit will show that there are a few unusual features and unusual ratings for some components. The contrast control, for instance, operates only on the first stage and is a simplified arrangement which permits of effective control without the risk of instability being introduced due to common stage couplings. The total bias resistance for each of the R.F. stages is higher than is customary, and this assists not only in stabilising the receiver but also reduces

the total H.T. consumption and gives a guarantee of longer life to the valves. It will be noted that the H.T. and L.T. supplies to the various valves are grouped and split. All heater "a" terminals are fed from one heater winding, and those marked "b" are fed from another separate winding. The H.T. supply is dropped to suit different stages, and in the vision and sound receivers it will be seen that in addition to using two separate feeds—one at 300 volts and one at 250 volts—the stages are successively decoupled so that a gradually increasing H.T. is applied from stage to stage up to the output.

Tuning Circuits

The tuned circuits in the vision receiver are single wound, permeability tuned units, all having the same windings, and utilising Aladdin formers. On the sound side transformer coupling is employed. The feed to the sound receiver is tapped off from the third R.F. stage, thus giving two R.F. stages common to both vision and sound. This coupling is effected through a very small condenser (3 pF) fed through an electrostatic screen into a 3in. length of coaxial cable to prevent radiation and feed-back from one unit to another. The anode load resistors act as dampers on the tuned circuits and flatten the tuning to provide the necessary band width, whilst the decoupling resistors, coupled with the alternative run of wiring, and the H.T. decouplers ensure that there is no feed-back through the H.T. supply to give rise to instability. Although standard types of interference suppressor are fitted to both units it must be remembered that they may be omitted if desired, simply ignoring the second section of the two double diodes. On the vision side there is some loss of brightness in some areas or districts it may not be necessary to use this part of the circuit.

RECEIVER

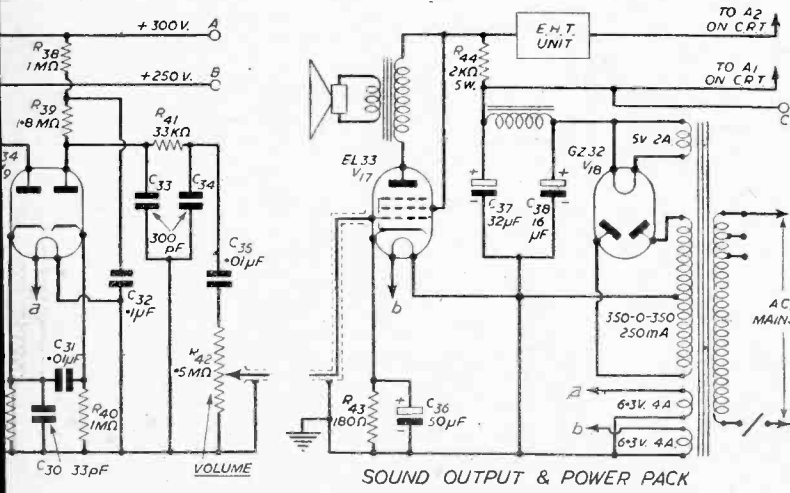
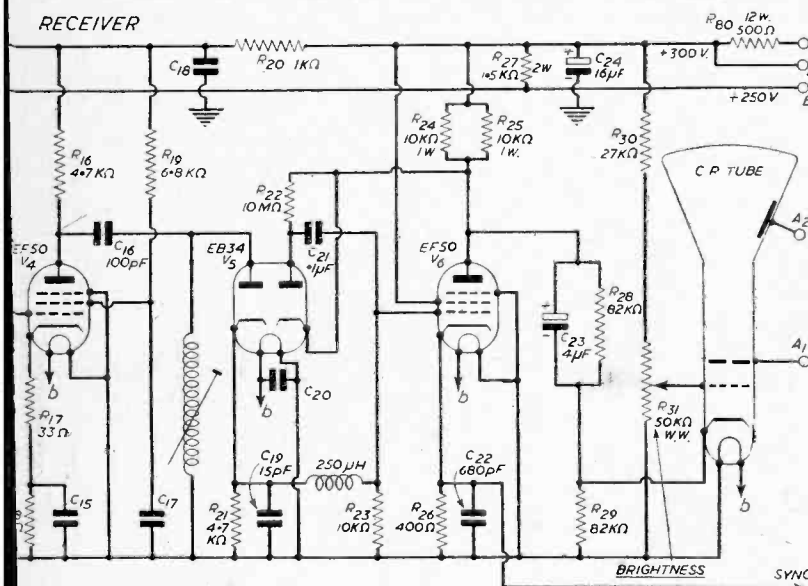

Sensitivity

For full modulation of the tube specified an input only a little in excess of 100 μ V is required so that the receiver should be perfectly satisfactory up to the fringe area. This input will give adequate sound output—this part of the circuit having its own volume control.

Controls

There are only two "panel" controls—the sound volume-control just mentioned, and a brilliance control combined with on/off switch. The latter may be omitted if desired, and a toggle type switch mounted in some part of the containing cabinet. Thi

iver. All condensers shown without a value are 1,000 pF (.001 μ F.)

latter arrangement is sometimes desirable where there are young children about who may be in the habit of playing with control knobs. As shown, the two controls are mounted on brackets, but they may be removed if required, the leads lengthened and the controls mounted on the cabinet in any desired position.

The contrast control is mounted on the chassis to act as a pre-set control, and once set up need not be touched unless the aerial is changed or valves age and call for increased input. The time-base controls are all mounted on the chassis and are provided with slotted spindles so that once set they need not be touched unless valves are changed.

Constructional Features

As will be seen later, resistors and condensers are, in the main, grouped on small group boards. These may be made up individually and they complete part of the wiring, so that when placed into position, interconnecting wires to valveholders, etc., complete the

wiring. Each group board is related to a definite part of the circuit, there being one for each of the time bases, one for the sync separator section, and one for a common input supply source. It will be noted in the circuits that there are separate large-capacity electrolytics shown at each section.

(To be continued)

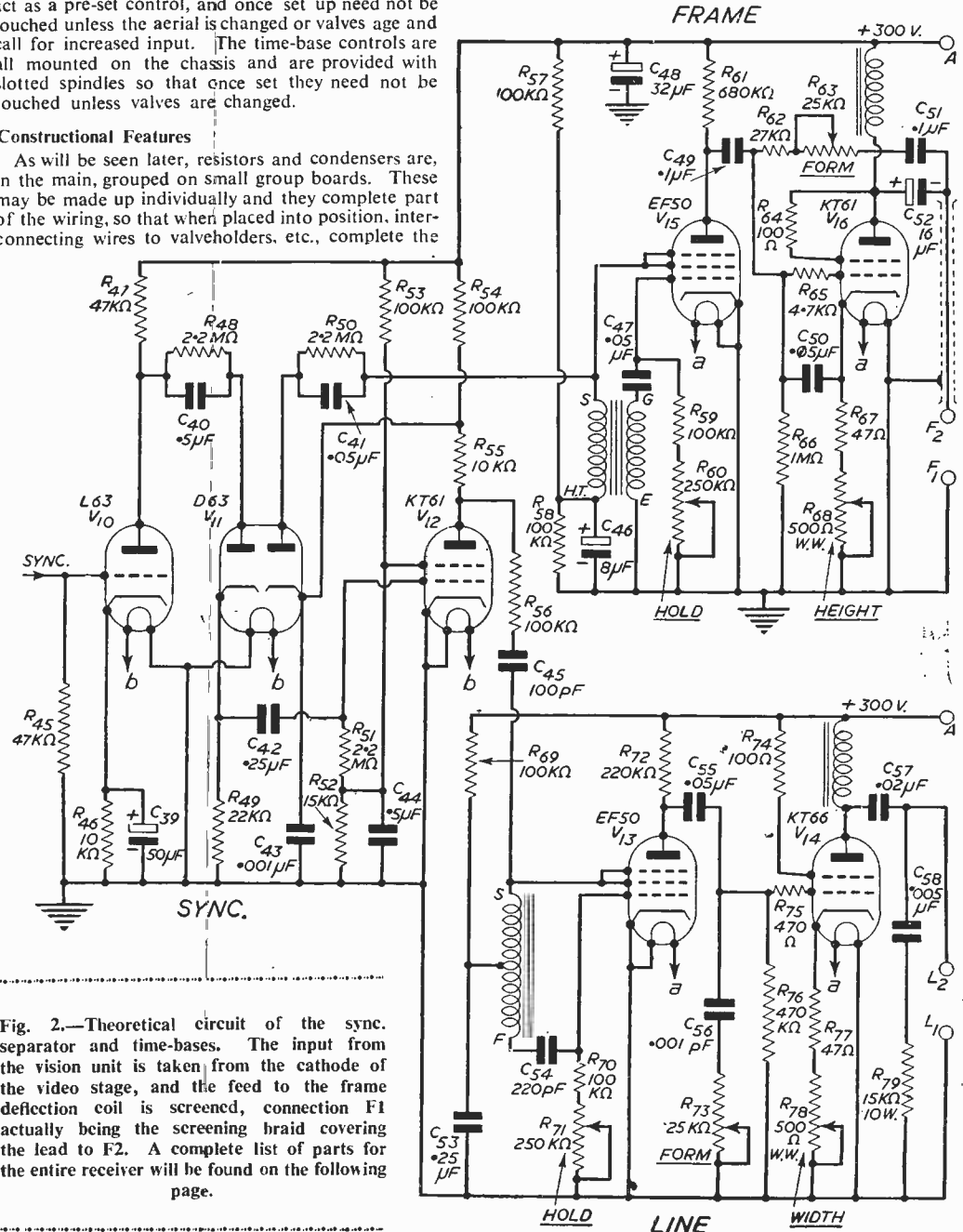

Fig. 2.—Theoretical circuit of the sync separator and time-bases. The input from the vision unit is taken from the cathode of the video stage, and the feed to the frame deflection coil is screened, connection F1 actually being the screening braid covering the lead to F2. A complete list of parts for the entire receiver will be found on the following page.

LIST OF COMPONENTS

CAPACITORS

C1, 2, 3, 5, 6, 8, 9, 11, 12, 14, 15, 17, 18, 20, 25, 26, 27, 28, 29, 43, 56	1,000 pF. Type CM2ON.	} T.C.C.	C30	33pF. Type SMWN	} T.C.C.
C4, 7, 13, 16, 45	100 pF. Type CM2ON.		C31, 3501μF. Type SMWN	
C10	3 pF. Ceramic		C33, 34	300pF. Type SMWN	
C19	15 pF. Type SMWN	C36, 39	50μF. Type BR.501	} Dubilier	
C21, 32, 49, 51	.1μF. Type 343	C37, 48	32 μF. Type CT.3250		
C22	680 pF. Type SM2N	C38	16μF. Type CT.1650	} T.C.C.	
C23	4μF. Type BR 435	C40, 445μF Type 343		
C24, 52	16 μF. Type BR.1650	C41, 47, 50, 55	.05μF. Type 343	} Dubilier	
		C42, 5325μF Type 343		
		C46	8μF Type BR.850	} T.C.C.	
		C54	220pF. Type MWN		
		C5702μF. Type 2045	} T.C.C.	
		C58005μF Type 2045		

RESISTORS

R1, 7, 9, 14	3.3kΩ	R38, 40, 66	1MΩ
R2, 45, 47	47kΩ	R39	1.8MΩ
R3, 34	2.2kΩ	R42	.5MΩ Type C Dubilier
R4, 32, 35	220Ω	R44	2kΩ—5 watt Welwyn
R5	10kΩ Type CLR.4089/22 Colvern	R48, 50, 51	2.2MΩ
R6, 8, 13	2.7kΩ	R49	22kΩ
R10, 17	33Ω	R52	15kΩ
R11, 15, 18, 43	180Ω	R53, 54, 56, 57, 58, 59, 69, 70	100kΩ
R12, 20	1kΩ	R60, 71	250kΩ Morganite Type "A"
R16, 21, 33, 36, 65	4.7kΩ	R61	680kΩ
R19	6.8kΩ	R63, 73	20kΩ Morganite Type "A"
R22	10MΩ	R64, 74	100Ω
R23, 46, 55	10kΩ	R67, 77	47Ω
R24, 25	10kΩ—1 watt	R68, 78	500Ω Type CLR.3001 Colvern
R26	400Ω	R72	220kΩ
R27	1.5kΩ—2 watt	R75	470Ω
R28, 29	82kΩ	R76	470kΩ
R30, 62	27kΩ	R79	15kΩ—10 watt Welwyn
R31	50kΩ (combined with on/off switch) Type CS Dubilier	R80	500Ω—12 watt Welwyn
R37, 41	33kΩ		

All above are Erie ½ watt type except where stated otherwise.

- Frame circuit feed choke, Type LUS8F
- Line circuit feed choke, Type LUS6L
- Frame oscillator transformer, Type TUY5/86
- Line oscillator transformer, Type TQ/116
- Scanning coil unit, Type S.914H.
- One P.M. focusing unit, Type R.17 or R.17/3
- Mains transformer, Type C. 281
- Smoothing choke, Type C.281
- R.F. E.H.T. unit, Type SH.8/50.—Hazelhurst Designs, Ltd.
- 10in. loudspeaker with 7,000-ohm transformer, Type S101.2T—Whiteley Electrical Radio Co., Ltd.

Haynes Radio, Ltd.

Electro Acoustic Industries, Ltd.

Gardners Radio, Ltd.

Valves :

Nine EF50	} Mullard	One L63	} Osram
Two EB34		One D63	
One EL33		Two KT61	
One GZ32		One KT66	

One C.R. tube, Type MW22-14c and base to suit—Mullard.

- Eight Formers, PP5925
- Eight Cores, PP5920 Grade "A"
- Four "Cinch" insulated double-bank mounting strips, No. 75,998
- Five 3-way tag strips.
- 250 μH choke (see text).
- Nine B9G ceramic valvholders, Type L500/C/Ag
- One 7-way plug and socket, Type L.530/531
- Nine octal valvholders
- One 3-pin shielded plug and socket, Type P.162—A. F. Bulgin & Co., Ltd.
- One rubber mask (black or white according to taste) Long & Hambly, Ltd.
- One piece ½ plate glass, 10in. by 8½in.
- Five-eighths plywood for speaker and tube mount.
- Aluminium and finplate for chassis.

Nuts ; bolts ; connecting wire ; P.V.C. insulating sleeving ; flex ; one yard rubber draught excluder ; six rubber grommets ; one yard coaxial cable ; one yard twin-screened cable ; one yard single screened cable ; few ounces 28 D.C.C. s.w.g. for coils.

Television Relay Service

Details of the Problem and Its Solution

DURING the past 25 years the utilisation of wire-broadcasting has increased until it now provides sound programmes to nearly a million homes. The system used in these wired broadcast networks is a simple one; the programmes required are received at a central station by a high-quality receiver, or in some instances direct from the studio by G.P.O. line; large amplifiers then redistribute the programme via street cables, which are normally suspended or cleated along the eaves of buildings. When the system has to cover a large area with a large number of users, the normal method is to establish amplifier sub-stations at certain points in the town, each sub-station then feeds radially to its particular district. The user's equipment consists merely of a speaker in a suitable cabinet, with a volume-control and programme selector switch.

It was felt that this form of distribution could be applied to television with great advantage, and, after experiments with a number of methods, a system has been developed which it is considered should satisfy all requirements for entertainment distribution. This system provides four alternative audio-programmes in the conventional manner, the distribution being along two cables of approximately $\frac{1}{2}$ in. diameter; a vision carrier is also fed along these cables, this carrier being re-modulated with the video signal received at the central station. If the user wishes to avail himself of the vision service, his speaker unit is changed for a simplified television receiver, which also serves as a speaker unit for the four sound programmes.

The basic principles underlying the development of a relay system, whether vision or broadcast sound, are the removal of complex equipment from a large number of individuals, and its unification as one central installation with adequate maintenance facilities. In this the entertainment relay is only following the logical course of any other public service; thus an improvement, which is too expensive for inclusion in every domestic receiver, becomes quite feasible when it only has to be included once at the central station, for its cost is then divided by the number of users obtaining benefit from it. For instance, the central station vision receiver is fitted with automatic gain control, which largely eliminates fading and aircraft flutter, giving a steady signal and removing picture-slip from the user's receiver. The audio-programmes can be used at any point without the necessity for a mains supply or a battery-operated receiver, the quality of the programmes can always be superior to that of a normal domestic receiver, since the domestic receiver has severe bandwidth limitations and is always liable to receive locally generated interference, while the facilities available and the precautions taken against interference at the central station are far beyond the scope of the average domestic listener. Programmes of particular interest from overseas can be picked up with a special communications receiver, and substituted for one of the normal programmes on the distribution system.

Interference

The question of interference is much more important when considering the vision aspect, since the domestic television receiver is liable to receive interference from any electrically operated equipment and, in many cases,

particularly in areas remote from the transmitter, this form of interference can make television reception impossible. The cure in these cases is to remove the receiving station to a selected point outside the town, and with a relay system this is quite possible; thus every user has the virtual advantage of living on a hill outside the town where the reception is the best that can be obtained in that area, with the additional advantage of the best possible receiver design and aerial array regardless of cost. If there is a particular source of interference which mars reception, special measures can be taken to eliminate this, either with directional-aerials or by other means.

If cable erection is carefully planned before commencement, the installation can be virtually invisible to a casual inspection, and is certainly less conspicuous or dangerous than the alternative collection of poles and aerials. The cable system has been developed to enable it to be installed in street conduits containing main wiring or other public services if necessary and, since it can be internally wired in building, the installation could be made completely invisible in any development area. In the case of large blocks of flats, a cable distribution system provides almost the only solution to television requirements by the tenants, since the alternative is a multiplicity of aerials and aerial feeders which is, in most cases, impracticable. In areas where it may be applicable at a later date, the installation has been designed to carry two alternative vision programmes. The system is completely flexible in that users wanting only the four sound programmes and those wanting the full service can be mixed in any order or ratio along the cables. If desired, the house can be wired to provide the service in a number of rooms.

The audio response of the system is normally of the order of 80 to 8,000 c.p.s., and the power provided to each speaker unit is approximately 500 milliwatts, although special units can be used for much larger powers if required. The frequency response of the vision carrier system is designed to give a video bandwidth at the user's receiver of 2.5 Mc/s, and the input level to the receiver is 50 per cent. more than is required for normal viewing. Although the standard receiver is a table model with a 9 in. tube, alternative models with 12 in. tubes or of the console type can be supplied if desired. This also applies to the sound installation, which is normally a speaker unit of the extension type, but can be supplied as a high-fidelity unit with an adequate baffle in special cases.

The economic aspect of an entertainment relay service cannot be fully explored here, but its immediate advantage can be seen in that it brings television within the scope of the person who cannot afford the capital outlay on a receiver and aerial of his own, and thus justifies the capital expenditure on the main system. Since the receivers can be regarded as an integral part of the relay, repairs and service are carried out as part of the system and do not involve the user in any expenditure, and since all receivers are basically the same, repairs are simple and economic.

It can be seen that a well-planned and properly operated entertainment relay will give the best possible results coupled with the minimum worry to the user.

SUMMER BARGAINS

R.1155 RECEIVERS. These world renowned 5 waveband R.A.F. Communications receivers are too well known for us to repeat the detailed specification. Every set is guaranteed in working order before despatch, and full details of adapting it for normal mains use are supplied. ONLY **£7.19.6** (carriage, etc., 12/6).

25/73 RECEIVERS. Part of the T.R.1196 covers 4.3-6.7 mcs., and makes an ideal basis for an all-wave superhet receiver. Complete with six valves; 2 each of EF36 and EF39, and 1 each EK32 and EBC33. Modification details supplied. ONLY **25/-** (postage, etc., 2/6.)

18 RECEIVERS. Part of the T.R. 18. Covers 6-9 mcs. and only requires normal battery supply to operate. Complete with 4 valves; 3 of VP23 and 1 of HL23DD. ONLY **17/6** (postage, etc., 2/6).

BATTERY AMPLIFIER. Ex R.A.F. Originally used for inter-comm, etc., but ideal for use as a pre-amp. stage or with gramophone pick-up. Complete with valves QP21 and HL210 in original transit cases. ONLY **25/-** (postage, etc., 2/6).

SELSYN MOTORS. Type SM1406 for 230/250 v. Brand New. ONLY **30/-** (carriage 2/6).

R.C.A. 100 kcs. CRYSTALS. A few available at ONLY **15/-**.

0-1 MA. PANEL METERS. 3½ in. diameter with 2½ in. scale. Brand NEW. ONLY **15/-**. (Postage, etc. 9d.)

TRANSFORMERS. 350-0-350 v. 160 ma. 5v. 3a. 6.3 v. 6a. 6.3 v. 3a. ONLY **36/-**. 250-0-250 v. 100 ma. 6.3 v. 6 a. 5 v. 3 a. ONLY **27/6**. 350-0-350 v. 80 ma. 6.3 v. 3a. CT, 5 v. 2 a. ONLY **26/6**. EHT for VCR97 tube, 2-0-2 v. 1.1 a. 2-0-2 v. 2 a. 2,500 v. 5 ma. ONLY **30/-**. Combined H.T./EHT 430-0-430 v. 200 ma, 4 v. 1 a. 4 v. 2 a. 5 v. 3 a. 6.3 v. 3 a. 6.3 v. 6 a. 2,500 v. 5 ma. ONLY **75/-** POSTAGE 1/6 PER TRANSFORMER PLEASE.

CHOKES. 5 h 200 ma. 6/-, 10 h. 100 ma 6/- (postage 9d.).

A.C./D.C. MIDGET POWER PACK. Originally made for MCR 1 receiver. Input 97-250 v. Output 120 v. H.T. and 7.5 v. L.T. Size 2¼ in. x 3¼ in. x 8½ in. ONLY **39/6** (postage 1/6).

TELEVISION MAGNIFYING LENS. First grade oil filled. For 6in. tube, **25/-**. For 9in. tube, **65/-** (postage 1/6).

TELEVISION KNOBS. 1½ in. Brown. Engraved "Contrast" "Focus" "Brightness" "Volume" "Switch," 1/6 each.

SEND a 2d. STAMP and your name and address for the New "Inexpensive Television" Price List, or a 2/9 Postal Order for the New 48-Page illustrated book which gives full details of converting various ex Govt. Radar Units to Television. Buy the gear NOW, at the low summer prices.

U.E.I. CORPORATION,

Radio Corner, 138, Grays Inn Road, London, W.C.1.

(Phone : TERMINUS 7937)

(Open until 1 p.m. Saturdays. We are 2 mins. from High Holborn (Chancery Lane Station) and 5 mins. by bus from King's Cross.

FOR YOUR TELEVISION COMPONENTS COME TO TELE-RADIO

You are sure of a welcome, courteous attention and efficient service from our technicians, whatever your television needs may be.

As specialists in the supply of first-rate components, we are able to display a fine range of Focus magnets, Scanning coils, C.R.T.s, Line and E.H.T. transformers, R.F. Oscillator units, High Voltage condensers—in fact, everything that goes to the making of a really superior televisor. And we are always glad to help with technical problems, large or small.

Our demonstration models of the 'Viewmaster' and the *Electronic Engineering* 'Home Built Televisor' are well worth seeing, but for those unable to call detailed price lists are available through our prompt postal service.

FREE! Write to-day for our comprehensive 48-page Catalogue, with Television Supplement (post free). All goods are despatched by return of post. Cash with Order or C.O.D.

We are open Monday-Saturday 9 a.m.-6 p.m. Thursday 9 a.m.-1 p.m.

TELE-RADIO (1943) LTD.

ONLY ADDRESS: 177, EDGWARE ROAD,
LONDON, W.2.

Phone: PAD 5606 or 6116.

WOLF ELECTRIC SOLDERGUNS

OFF-STRAIGHT EASY-GRIP HANDLE
PERFECT CONTROL
QUICKER HEAT UP
LOCALISED HEAT
LOW CURRENT CONSUMPTION
MAINTAINS CORRECT HEAT
A MODEL FOR EVERY PURPOSE

Obtainable from all leading tool merchants and factors. Write for **FREE** illustrated technical literature.

**WOLF ELECTRIC TOOLS LTD.,
HANGER LANE. LONDON, W.5.**

"YOU CAN RELY ON US"
FOR CLEAN COMPONENTS
AT COMPETITIVE PRICES

IMMEDIATE DISPATCH

MORE QUALITY BARGAINS :-

	VALVES	
AZ32	9/- U50	7/6
CIC	8/- IT4	7/6
CY31	8/- 185	7/6
CH35	8/6 115	8/-
CL33	10/- 354	8/6
DH63	7/6 524	7/6
DF33	8/- 6V8G	7/6
EA50	2/6 6X5	6/6
EB33	7/8 6K7	7/8
ECC32	8/- 125Rft	8/-
EL35	9/- 25A6	9/-
EM34	7/6 25Y5	9/-
EL33	10/- 25Y5G	9/-
EBC32	8/6 35Z6G	9/-
ECH35	11/- 25L5	8/-
EF39	11/- 43	8/-
EBL31	11/- 76	6/-
EF8	10/- 77	6/-
G232	10/6 78	9/6
IV4A	9/- 80	9/-
KTW61	7/8 11	6/-
6AL5	7/8 39/44	6/6
SP4(5)	8/- Post 6d.any quantity	

The Above are NEW makers' valves

NEW BOXED EX-GOVT. VALVES

IC5gt	7/6 9L7 Metal	7/-
5Z4 Metal	7/6 5S4gt	6/6
5Z3G	7/- 5J7gt	7/-
6C5gt	7/- 5SK7 Metal	7/-
6F6 Metal	7/6 5L7	7/-
6F6G	7/- 6XY5	6/-
6F7G	6/6 EF50 (VR91)	6/-
6C8G	6/6 12J5gt	6/-
616gt	3/- 12K9 Metal	7/6
615C	6/- 12S F5 Metal	6/-
6J5gt	6/6 12S47 Metal	6/6
6C4	7/6 807	7/6
6J7 Metal	7/6 954	5/-
6J8G	6/6 955	6/-
6K7 Metal	7/6 9003	6/-
6K8	7/6 VU111	7/6
6L6G	10/4	

- COILS**
 Medium wave iron-cored with reaction (SM1D) ... 3/6
 TRF MW/LW matched pair with circuit ... 7/8
- FORMERS**
 Aladdin fin. with cores ... each 10d.
 Aladdin fin. with cores ... each 7d.
 fin. Bakelite with adjustable iron core ... each 9d.
- FILAMENT TRANSFORMERS**
 210/240 v. to 6.3 1.5 a. Small with green crackle finish ... 8/6
 210/240 v. to 4 v. 3 a. ... 12/6
- SPEAKER TRANSFORMERS**
 Super midget. to match 354. DL92. to 2-3 ohm ... 4/3
- LOUDSPEAKERS**
 2in. Celestion Midget. 25/6 3in. 12/6
 5in. with dust cover. 9/8 5in. Television Type small magnet. 10/6 5in. Goodmans. 12/6 6in. Truvox with trans. 16/- 8in. Lightweight Television type. 15/- 8in. R. & A. with pentode trans. 18/6 10in. Television type. 21/6 12in. Truvox. 39/6

- HAYNES COMPONENTS**
 for "Practical Wireless Television" stocked.
 Scanning coil Type 5914H ... 38/3
 Transformer Type TUY5-88 ... 20/-
 Transformer Type TQ116 ... 10/-
 Choke Type LUS8F ... 20/-
 Choke Type LUS6L ... 15/-
 Focusing Unit R17 ... 21/-

VIEWMASTER TELEVISOR
 Complete set of instructions (State London or Midland) ... 5/-
 All parts stocked and sold separately if required.

Write, Phone, or Call for:
 CATALOGUE No. 7, 21d. Stamp.

RADIO SERVICING CO.
 444, WANDSWORTH ROAD,
 CLAPHAM, LONDON, S.W.8.
 Telephone: MACaulay 4155.
 77, 77A Bus; 26, 28 Tram. S.R. Station,
 Wandsworth Road.

CABOT RADIO

A New Television Pre-amplifier

Model B. Has an effective gain of 10 times, and an extremely high signal/noise ratio. Capable of operating at an input of 5 microV. without showing deterioration of picture quality due to its own generated noise. Uses Mazda 6F1 valve in an up-to-date circuit. Bandwidth 5 mcs. Entirely self-contained, and operates from 200-250 v. A.C. 50 c.p.s. only. Size: App. 4in. cubed. Available for London or Birmingham frequencies from your own dealer.

Price **£5.15.0**
 Including 6F1 valve.

If in difficulty write direct to:

Cabot Radio Co. Ltd.,
 28, Bedminster Parade,
 Bristol 3
 Tel.: 64314

BE CERTAIN OF SUCCESS BUILD THE

"VIEW MASTER"
 WITH SPECIFIED COMPONENTS FROM

COULPHONE RADIO

"The Return of Post Mail Order Service"
 * Results equal to the best commercial receivers.
 * No knowledge of Television required. *
 * Easily assembled and aligned. *

SEND NOW FOR CONSTRUCTIONAL ENVELOPE 5/-
ALL SPECIFIED KITS AND INDIVIDUAL COMPONENTS IN STOCK

INEXPENSIVE TELEVISION
 New book just published. 52 pages with 42 illustrations.

POST PAID 2/6 CONTENTS:
 EHT Power supplies, including RF. CRT Data and networks for all ex-Govt. tubes. TIME BASES, including power supplies. VISION RECEIVER, using R1355, RF28. RF27, 45 Mc/s. IF strip. SOUND RECEIVER, using R1355. THE TV AERIAL. Full data. PICTURE FAULTS ILLUSTRATED. ALL COMPONENTS FOR THE INEXPENSIVE TV RECEIVER FROM STOCK. AT THE LOWEST PRICES—by "The Return of POST MAIL ORDER SERVICE."

GUARANTEED EX-GOVT. VALVES.
 VCR97 6in. Tubes in original cases. £1 12 6, EF50 7/6, 6A67 5/-, 6V6G 6/-, 5Z4 6/-, 6L6 9/6, 6Q7 6/-, EA50 3/3, 6K7G 6/-, 6K8 6/6, 6J6 9/6.

6d. P.O. WILL BRING YOU
 64-PAGE CATALOGUE.
 It will save you Pounds.
COULPHONE RADIO, DEPT. PT4
 53, BURSCOUGH STREET, ORMSKIRK,
 LANCS. Phone 987.

-HENRY'S-

VALVES. The following valves, ex-Government, brand new and guaranteed, can be supplied—6J6 at 12/6, PEN46, 6L6 metal at 10/- each. EF50, EF54, EF55, RL37, VU120A, VU111, VU133, U18, 5T4, 5R4YQ, RL18, 6F7, 6AG5, PM22A, all at 7/6 each. 5U4, 6SN7GT, 5Z4, MU14, 6K7GT, 6J7GT, 6K3GT, ML12, 12S17, 12S17, 12SK7, 6SL7GT, 6SCTGT, 6C6, 6V6G or GT, 7C7, 7T4, 7S7, 7B6, 7C5, 1299A, 9D2, VP23, P2, 12A6, 8D2, 15D2, EF36, EF39, EBC33, EK32, EL32, 6X5GT, 2X2, 6AC7, 6N7, 78, 9003, IN5GT, 6J5GT, 6G5, KTW50, DH63, TDD2A, VP2B, AC6Pen, EP8, all at 6/6 each. Also 9002 and ILN5GT, 8/6, 807, 7-, 4D1, 5-, EA50, SP61, 954, EB34, at 3/6 each. DI Diode at 2/6 only. And the midget range of 1.4v. battery valves 1T4 and 1S5 at 8/6 each; 1R5 and 1S4 7/6, 3S4 at 5/6 each. Most of these valves are boxed. In addition to the above few types we have tremendous stocks of both ex-Govt. new valves at equally competitive prices and B.V.A. valves at current B.O.T. prices.

R.3515, I.F. STRIP. A complete I.F. Unit, comprising 6 SP16 I.F. Stages, tubes, 1 12SK7, 1 12S17, diode detector, and 1 EF36 or EF39 output or video stage. A few modifications only are required to adapt this unit, which will give pictures of extremely good quality. Price £1. complete with valves, and foolproof modification instructions, is 45s. plus 5s. packing and carriage. Limited quantity only.

TYPE 6A INDICATOR UNITS. As recommended for ex-Govt. T/V construction. Absolutely complete (included VCR97 with mu-metal shield, 4 EF50 and 3 6B34). Limited quantity only, at 67/6 each, plus 7/6 carriage and packing.

TYPE 6C INDICATOR UNITS. Comprising 3in. VCR138 C.R.T. with mu-metal screen, 2 EF50, 2 EB34, plus high voltage condenser and resistors. In good condition, price 45/- only. 10 MFD. 2,000 V.W. OIL FILLED GENERAL ELECTRIC 'PYRANOL' CAPACITORS. Size 4in. x 4in. x 4in. Porcelain terminals. Each individually wrapped at absolutely brand new. Price only 17/6 each.

'PHOTOFASH' ENTHUSIASTS. Please note that we have in stock T.C.C. 'Hykanol' Capacitors, 33 mfd. 5 K.V. at 47/10s. ea., also Mullard Tube LSD3 at 45/-.

DUAL PURPOSE MAINS TRANSFORMERS. Special 350-0-350v 80 m/a. 6.4v tapped 4v. at 3a., 5v. tapped 4v at 2a. Top chassis mounting, and fully guaranteed. 18/6 only plus 9d. post.

IGRANIC MAINS TRANSFORMER. A special purchase enables us to offer the following—1250-0-250, 70 m/a., 6.3v. 2a., 5v. 2a., half-shrouded, drop-through type, with voltage adjuster panel. Absolutely brand new and guaranteed. 15/- only, plus 9d. post.

R.1355 MAINS TRANSFORMER. 200/250v input. Outputs 250-0-250, at 120 m/a., 6.3v at 6a., 5v at 3a. Fully shrouded top chassis mounting and guaranteed 100 per cent. Only 28/6.

MINIATURE MAINS TRANSFORMER. 250-0-250, 60 m/a., 6v. 3 a., 5v. 2a., fully shrouded, well finished, size 3in. x 3in. x 2 1/2in. Price only 28/6.

NEW 18 SET RECEIVER PORTION. A four-wave superhet receiver operating from 6-9 Mc/s (33 m-50m). Valve line-up 3 AR P12 (VP23), and AR3 (HL23DD). Requires only 12w H.T., 9v C.B. and 1.1T. In perfect condition, only 17/6, plus 1/6 packing and carriage. An absolute bargain. Suitable brand new headphones can be supplied at 3/6 per pair.

N.B.—Each receiver is tested working prior to despatch.
5 K.V. ELECTROSTATIC VOLT-METER. 0-5 kV., panel-mounting 3 1/2in. scale, brand new. 50/- each.
WE ARE PLEASED TO ANNOUNCE THAT WE ARE ONCE AGAIN ABLE TO OFFER A RETURN OF POST SERVICE.
 Send stamp for current components list.

5 Harrow Road, London, W.2
 PADDINGTON 1008/9-0401



Wired Television

SIR ALEXANDER MAXWELL, chief of the Tourist Board was present with the Postmaster General, Mr. Ness Edwards when the management of the Green Park Hotel, London, demonstrated their new wired television service. Television is provided in every room. Sir Alexander Maxwell in an aside to the P.M.G. said: "I hope you realise that television is on only in the evening, when tourists should be out spending dollars, and if you think this scheme is going to appeal to the honeymoon couples, you're crazy, Sir."

Engineer-in-Charge, Lime Grove

MR. M. H. HALL has been appointed Engineer-in-Charge of the new B.B.C. Television Studio Centre at Lime Grove, Shepherd's Bush, London, W.12.

Mr. Hall has been with the B.B.C. since 1927, and was a member of the original staff at Alexandra Palace when the high-definition television service started in 1936. During the war he was Assistant Engineer-in-Charge successively of the Start Point and Woofferton transmitting stations. In 1946 he returned to Alexandra Palace, becoming Assistant Engineer-in-Charge there at the beginning of this year.

Television Viewers Visit EKCO

A PARTY of approximately 35 members of the British Television Viewers' Society from Croydon visited the factory of E. K. Cole Ltd., at Southend-on-Sea, on May 17. The main item of interest during the tour of the plant was, of course, the production of Ekcovision receivers, but the party were also able to see the radio, plastic and other divisions of the company at work.

The activities of the society, which was formed in 1947, cover tours of television studios, technical assistance to members, and monthly meetings at which guest speakers, including B.B.C. personalities are present.

Reflected TV

AN aluminium mirror is used to reflect television signals in a studio-transmitter link of WNBC-TV

in Binghamton, N.Y. Such links are usually provided by special land lines or by a line-of-sight microwave beam. In this case, the transmitter building was on the far slope of a wooded hill about 3½ miles from the studio and a land line up the hill would have been very expensive.

Festival of Britain

IN preparation for the Festival of Britain, the B.B.C. have ordered a new outside broadcast control van,

and ancillary equipment which includes five new Image Orthicon cameras said to be the most sensitive television cameras in the world.

Contract for these items, together with equipment for the Lime Grove studios has been placed with Pye Limited of Cambridge, and is worth more than £56,000.

Scottish Television Station

THE contract for the site works and the construction of the

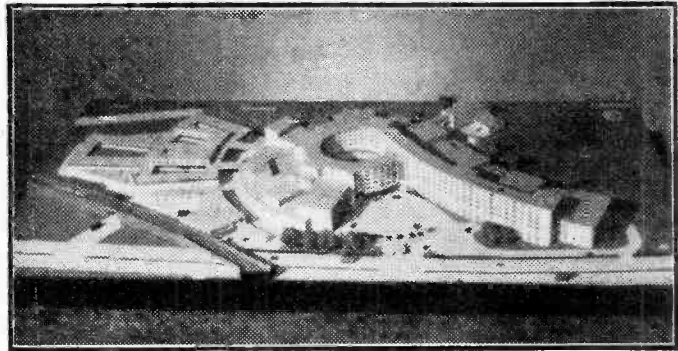

A model of the proposed new H.Q. of the B.B.C. at the White City. See the details on page 150.

The Editor will be pleased to consider articles of a practical nature suitable for publication in "Practical Television." Such articles should be written on one side of the paper only, and should contain the name and address of the sender. Whilst the Editor does not hold himself responsible for manuscripts, every effort will be made to return them if a stamped and addressed envelope is enclosed. All correspondence intended for the Editor should be addressed to: The Editor, "Practical Television," George Newnes, Ltd., Tower House, Southampton Street, Strand, W.C.2.

Owing to the rapid progress in the design of wireless apparatus and to our efforts to keep our readers in touch with the latest developments, we give no warranty that apparatus described in our columns is not the subject of letters patent.

Copyright in all drawings, photographs and articles published in "Practical Television" is specifically reserved throughout the countries signatory to the Berne Convention and the U.S.A. Reproductions or imitations of any of these are therefore expressly forbidden.

approach roads for the main Scottish television transmitting station at Kirk o'Shotts has been awarded to Messrs. McLean and Company of Wishaw, Lanarkshire.

This station will have a 750 ft. mast similar to those at Sutton Coldfield and Holme Moss. An order for the construction and erection of the mast has been placed with British Insulated Callender's Construction Company, Limited, of London.

Broadcast Interference

INTERFERENCE from local oscillators in television receivers is a very serious problem according to Chairman Wayne Coy of the Federal Communications Commission. The F.C.C. hopes to get away from this problem by opening up the U.H.F. range to television broadcasting.

Mr. Coy told a House sub-committee that the oscillators of some tele-

vision receivers put out enough power to put out of commission all the receivers within a 1-mile radius. He said that the Boston-Providence area is bothered with this trouble and that there are 32,000 receivers in this area which cannot get either of two channel broadcasts because of it.

Broadcast Receiving Licences

THE following statement shows the approximate numbers of licences issued during the year ended April 30th, 1950.



Television viewers at the Ekco factory. A party of members of the Croydon Society are seen here admiring one of the new models.

Region	Number
London Postal ..	2,309,000
Home Counties ..	1,627,000
Midland ..	1,715,000
North Eastern ..	1,878,000
North Western ..	1,587,000
South Western ..	1,048,000
Welsh and Border Counties	722,000
Total England and Wales	10,886,000
Scotland ..	1,115,000
Northern Ireland ..	203,000
Grand Total ..	12,204,000

The above total includes 363,950 television licences.

Orders for New Television Equipment

THE B.B.C. has ordered four sets of television camera equipment, two from Marconi's Wireless Telegraph Co., Ltd., and two from Pye Ltd.

Two of these equipments, each comprising a mobile control room with three operational cameras and associated equipment, will be used initially

at the Festival of Britain next year.

The other two equipments, each providing three operational cameras with their control equipment, will be used for the new television studios at Lime Grove, Shepherd's Bush, and for outside broadcasts.

Television Mast Contracts

FOLLOWING upon their notable achievement in the construction of the 750ft. high television mast at Sutton Coldfield, British Insulated Callender's Construction Co. Ltd.,

have now been entrusted with the design supply and erection of two similar masts—to the B.B.C.'s specifications for the Corporation's projected television stations at Holme Moss, near Huddersfield, and Kirk O'Shotts, near Glasgow.

The construction of foundations at Holme Moss will begin within the next few weeks, and it is expected that the erection of the mast will be completed by early autumn this year. Erection of the Kirk O'Shotts mast will be commenced in 1951.

The design of the new masts will be on the same lines as that of the Sutton Coldfield structure, which has already become a familiar landmark in the Midlands. This mast, it will be recalled, is of stayed lattice steel construction with a 9ft. triangular cross section for the first 600ft., and tubular steel construction for the next 110ft. Surmounting this section is a short square tower which carries the television aerial system.

When the two new television masts are put into operation, in 1951 and

1952 respectively, the third and fourth links in the proposed chain of television stations in the United Kingdom will have been established. This will bring television service within the range of the highly populated areas of Northern England and the Scottish Lowlands.

Orders for New Transmitters

THE B.B.C. announces that the three 5-kilowatt vision transmitters and three 2-kilowatt sound transmitters have been ordered from Marconi's Wireless Telegraph Company, Ltd., for the television service.

Television Service

INSURANCE covering renewal contracts is becoming a "necessary evil" in New York, according to several contractors and dealers. More and more customers are demanding insurance coverage of their second-year service contracts, but dealers and contractors are not certain that they will gain by having coverage by a surety company.

Retailers and service firms seem to be confused as to whether the New York State Insurance provision is a law or merely the opinion of an Attorney General.

Danish Tests

WE understand that tests are radiated from Denmark's experimental station on Mondays (11 a.m.-4 p.m.), Wednesday and Friday (11 a.m.-4 p.m. and 8 p.m.-9 p.m.) and on Saturday 11 a.m.-noon (all times are B.S.T.). The frequencies used are 62.5 Mc/s for vision, and 67.75 Mc/s for sound. The system uses 625 lines, double sideband with positive picture modulation.

Canadian Television

PLANS have now been announced for the Canadian Television System. It is tentatively planned to have two stations in Montreal (one using French and the other the English language) and a station in Toronto. Preliminary air tests are expected in September, 1951.

OUR COMPANION JOURNALS

Practical Engineering, 4d. Every Friday
Practical Mechanics, 9d. Every Month
Practical Wireless, 9d. Every Month



Model TV 20 inc. 12" Tube and 21 valve circuit operating on 200-250 volt A.C. mains with two main controls and SIX pre-set adjusters, completely enclosed E.H.T. unit and separate 10" loud-speaker.

Yes, Armstrong Television has been demonstrated to be absolutely efficient, particularly when used in the "fringe" areas, and all agree that the brilliant high definition in picture and excellent reproduction are worthy of the Armstrong tradition. Write now for complete specification.

Armstrong THE CHASSIS PEOPLE

Armstrong Wireless & Television Co., Ltd., Warlters Road, Holloway, London, N.7. Tel.: NORTH 3213

SOLE BIRMINGHAM AGENT:

Hayes Company, 1, Alcester Road, Moseley, Birmingham, 13. 5032

G2AK CHAS. H. YOUNG G2AK FOR TELEVISION COMPONENTS

Full range in stock for
View Master and E.E. Televisors.

View Master Envelope, Instruction Book, Plans and Diagrams, 5/-; Instruction Book with Plans, etc., for E.E. Televisor, 4/6.

Complete Kits or any individual components supplied separately for stage by stage building.

E.H.T. TRANSFORMERS. Output 2,500 v., 4 v. 1 a., 2.0-2v. 2a. (For VCR97). Fully impregnated, 36/-.

Power Transformers. 320/320 v. 130 ma., 6.3 v. 6 a. CT., 5 v. 3 a., Primary 200/250 50 c. Drop through type, 22/6, post 1/6.

Tub. Condensers. '01 5 kV., 1/6; '02 8 kV., 2/-.

Meters. 500 microamperes, 7/6; 100 microamperes, 22/6.

Twin Feeder, 70 ohms, 5d. per yard.

Co-Ax Cable. 1/4 in. dia. 70 ohms. Low loss, just the thing for fringe area reception, 8d. per yard. Any length cut up to 100 yards. Standard 1/4 in. dia. Co-Ax, 1/- per yard. Twin ditto, 1/3 per yard. Postage on any length cable 1/6.

SPECIAL VALVE OFFER. We will give you 25 per cent. Discount on your order for 12 or more from list below. These may be all one type or mixed as you wish. 9002, 9003, 954, 955, 956, 6H6, 6SH7, 4/6; 6J5, 5Z4, 6SN7, 6J7, 6K7, 6K8, 6C5gt, 6Q7gt, 6SJ7, 6SK7gt, 6G6, 6SC7, 6SA7, 6AG7, 6SG7, 6SF5, 6N7, 6L7, 6F50, 6D6, 6C6, 6F7, 6B7, 6U10, 6UJ39, 6V6, 6F6g, 12SK7, 12K8, 12SQ7, 12A6, 7/6; OZ4, 6C4, 5U4, 1616, 5X4, 5Y4, 5Y3, 717A, 6F55, R10, CV52, 9/-; 6AK5, 11/-; 6J6, 12/6; 931A (Photocell/Multiplier), 30/-.

CHAS. H. YOUNG, G2AK 110 DALE END, BIRMINGHAM

Telephone: CENTRAL 1635

LASKY'S RADIO SPECIAL RETURN OF POST SERVICE FOR NON-CALLERS. (Mark orders and enquiries TV/RUSH.)

EVERYTHING FOR THE TELEVISION CONSTRUCTOR
SHOP AT LASKY'S AND SAVE CASH

SEE THE VIEWMASTER. Demonstrations every day during transmitting hours. All components to build this receiver in stock. The Viewmaster Construction Envelope. Model A London, model B Sutton Coldfield. PRICE 5/- per copy, post free.

The Viewmaster Pre-Amplifier kit. Complete with valve, 44/10, Kit less valve, 23/6, postage 1/- per kit extra. Data for London and Sutton Coldfield available.

SPECIAL VIEWMASTER VALVE KIT. Set of 12 valves, as specified. LASKY'S PRICE, 97/-, POST FREE.

Consists of: 5 EF50; 1 6P28; 2 6K25; 1 EB91; 1 EBC33 or DH63; 2 KT61.

VR91 valves equiv. EF50. 1st grade 7/6 each, 2nd grade 5/- each. T41 and 6K25 thyratrons, 12/10 each. KT61 valves, 7/6. DH63 and EBC33 valves, 6/- each. EB91 valves, 12/10. EF91 valves, 21/4. 6P28 valves, 21/4.

LASKY'S SPECIAL OFFER. WHITE RUBBER MASKS. 6in. square, 7/-; 9in. square, white, 7/6. 12in. white (soiled), 12/6. 12in. black (soiled), 10/6. Also 6in. round black, 3/6, post 6d. extra.

Safety glass for 7in. C.R. tubes, 2/6 per sheet. For 9in. C.R. tubes, 3/6 per sheet. Postage 6d. per sheet extra.

EX-GOVERNMENT CATHODE RAY TUBES. ALL BRAND NEW, IN MAKER'S SPRUNG WOOD CASE. TYPE VCR 97. 6in. short persistence. LASKY'S PRICE, 35/-. TYPE VCR 517. 6in. medium persistence. LASKY'S PRICE, 35/-. Carriage free.

SPECIAL SCANNING COILS FOR 9 or 12in. C.R. TUBES. LASKY'S PRICE, 15/-, postage 1/- extra.

Send a 2d. stamp with your name and address for a copy of our current stock list of Ex-Government radio and radar equipment. The Lasky's Radio Bulletin.

LASKY'S RADIO

370, HARROW ROAD, PADDINGTON, LONDON, W.9. CUNningham 1979. (Opposite Paddington Hospital.) Hours: Mon. to Sat. 9.30 a.m. to 6 p.m. Thurs. half day.

Build with
the Best

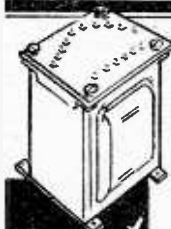

TELEVISION TRANSFORMERS & CHOKES

In choosing components the amateur constructor MUST have reliability and quality as his "safeguard" to success. That is why "SOMERFORD" components are outstanding in the field of home-built televisors.



GARDNERS RADIO Ltd

SOMERFORD, CHRISTCHURCH, HANTS.
Telephone: Christchurch 1025

Please send me details of components for home-built televisors.

NAME

ADDRESS

.....

THINKING OF BUILDING A TELEVISION SET ?

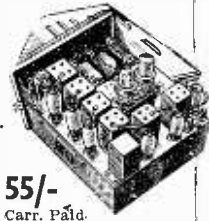

**10 VALVE
1½ METRE
SUPER-
HET.** Ideal for conversion into Television Receivers. **I.F.**

55/-
Carr. Paid

12 Megs. Band width 4 megs. Co-axial input and output sockets. 10 Mazda Mains type VR65 (SP61) valves, 6.3 volt filaments. This chassis can be quickly modified for reception of sound and vision. The Pre-H.F. oscillator and mixer inductances may be shunted with 30 p.f. trimmers to cover TIV frequency. Three of the I.F. circuits can be used for video and two isolated for audio.

Dept. P.T., WIRELESS INSTRUMENTS (Leeds), Ltd., 54/56, The Headrow Leeds
Tel. 22262

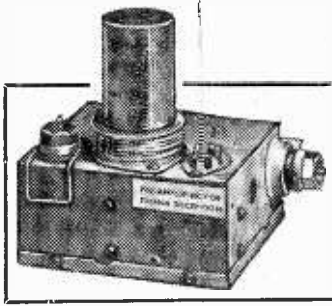

TELEVISION PRE-AMPLIFIER

Just the thing you have been looking for. This Ex-Govt. 1-valve pre-amplifier is extremely sensitive and stable. It makes an amazing improvement in both vision and sound reception in all fringe areas. Now available for both London (type A) and Birmingham (type B).

Very small dimensions. Length, 4in. Width, 3in. Chassis depth, 1in. Overall depth to top of valve 4in.

Fitted with EF50 valve. Ready for use. Power requirements 6.3 v. L.T. 200/275 v. H.T. Coax. Input and Output sockets. Ideal for "The Viewmaster", "The Inexpensive Television Set", Electronic Engineering Television, and any commercial set with suitable power supply. Unique value at the price of

15/- (Post 1/-)

All Tested and Guaranteed before despatch. Prompt Delivery. Obtainable only from

H.P. RADIO SERVICES LTD.

Britain's Leading Radio Mail Order House

55, COUNTY ROAD, WALTON, LIVERPOOL, 4. Tel.: Aintree 1445

POST RADIO SUPPLIES

COPPER INSTRUMENT WIRE. ENAMELLED, TINNED AND FUSE. COTTON AND SILK COVERED. LITZ WIRES. Most gauges available. **B.A. SCREWS, NUTS, WASHERS,** soldering tags, eyelets and rivets. **EBONITE AND LAMINATED BAKE-LITE PANELS, TUFNOL ROD. PAXOLIN TYPE COIL FORMERS AND TUBES, ALL DIAMETERS. PERMANENT DETECTORS, CRYSTALS, EARPHONES, etc.** Latest Radio Publications. Full Range Available.

Send stamped addressed envelope for comprehensive lists. Trade supplied.

POST RADIO SUPPLIES
33, Bourne Gardens, London, E.4.

RADIOLECTRON

22 FRANCES STREET, SCUNTHORPE, Lincs.

COMPONENTS FOR 'PRACTICAL WIRELESS' TELEVISION RECEIVER. CONDENSERS, Paper Tubulars. 500v wkg. .01. 11d.; .05. 1. 1/-; .25. 1/2; .5. 2/-; 2.000v. wkg. .005. 1/8; .02. 2/-; Electrolytic. 4 mfd., 3/6; 8. 4/-; 16. 6/-; 32. 9/6; Silvered Mica. 15 Pf. to 35 Pf. 9d.; 200 Pf. to 300 Pf., 1/-; Mica. 100 Pf. 9d.; 1,000 Pf. 1/-; RESISTANCES. 1 Watt. 4d.; 1 Watt. 7d.; 2 Watt. 1/3; 5 Watt. 2/-; Mounting Strips, double bank. 1/8.

Tag Strips, 3-way. 3d.
Valve Holders. Ceramic B9G. 1/6; Octal. 11d.

Masks. White Rubber for Tube MW22-14C. 1/3. Coax Cable. 1/- yd. Twin Screened Cable. 1/- yd.; Single. 7d. yd. Connecting Wire. 2/d. yd. Insulating Sleeving. 4d. yd. Wire. silk covered, for Coils. 32 s.w.g. 4oz. 5/-.

Terms.—Cash with Order, up to 10/-, 4d. Post, over Post Free. List 21d. Stamp. Please print your name and address on all correspondence.

TELEVISION COILS

(Suitable for Viewmaster)

MIDLAND WAVELENGTH 25/6

LONDON WAVELENGTH 18/6

per complete set.

From your local retailer, usual factor, or—

British Distributing Co.
66, High Street, London, N.8

You can master MATHEMATICS

If you wish to understand radio and television thoroughly you must know Mathematics. Our new Home-Study Courses make them really interesting and easy to learn.

T. & C. RADIO COLLEGE

Specialists in Home-Study Tuition in Mathematics, Radio & Television.

Write for free booklet "T" to:—

R. Heath Bradley, T. C. R. C.
50, Harland Road,
SOUTHBOURNE, BOURNEMOUTH.

BARGAINS

in slightly used

Television Receivers

BUSH Model T91 Console,
39 gns.

EKCO Model TSC30 Console,
£37 10s. 0d.

Cossor Model 1210 Console,
59 gns.

15in. Tube with Radio

Viewmaster Chassis, Less Tube,
£29 10s. 0d.

Also full stocks of High Quality Amplifiers, Pick-ups, Speakers and Tuners by the following Makers. **Leak, Sound Sales, Armstrong, Charles, Goodmans, W.B., Barker, Arcos, Wharfedale.**

HOLLEY'S RADIO STORES

285, Camberwell Road, S.E.5

'Phone : RODney 4988

LONDON CENTRAL RADIO STORES

PHOTO ELECTRIC CELLS. Type GS17. Gas filled, made by Cintel 100µAl Lumen, working volts 100 D.C. or peak A.C., projected Cathode Area 16 sq. cm., suitable for many devices—burglar alarms, automatic countings, and 16 mm. talkie equipment, etc. Brand New in original cartons, 42/6 each.

PHOTO ELECTRIC CELLS. Type C.V.143. Infra-red Image Glass Converter tubes, suitable for many purposes—opening doors, burglar alarms, etc., 14/6 each.

L.F. CHOKES by Parmeko. 200 m.a. D.C., 3 Henries, suitable for Television. New, in original cartons, 7/6 each.

ACCUMULATORS. Heavy Duty, 6 volts, 125 amps. Size 12ins. x 9ins. x 7ins, New, £41/10/0 each.

VALVES. EF50, 5/6 each. SP41, 4 volt. 6.3, 3/6 each. 6J5, 3/6 each. EA50 and DI, 2/6 each.

ALL GOODS CARRIAGE PAID IN GT. BRITAIN AND NORTHERN IRELAND.

23, LISLE STREET, W.C.2

Telephone: GERrard 2969

TELEVISION PRODUCTION

B.B.C. Producer ROYSTON MORLEY
Discusses the Problems of Modern Programmes

PRODUCING plays needs two kinds of knowledge, of writers and of actors. The search for new plays and new authors goes on all the time. The search for actors is also continuous, but in television dramatic production it reaches a peak every four or five weeks—because for the individual producer there is generally about a month's gap between productions. Casting cannot, as a rule, be done much in advance of the start of rehearsals, because of the difficulty of knowing just what actors will be free from other commitments.

Acting for television requires a stage approach to the part and a film technique for playing it, plus certain other abilities peculiar to the new medium. By "stage approach" I mean the ability to assess and understand a part as a whole, the ability to sustain the part in continuous action, to gauge the emotional and dramatic "peaks" and balance them against each other, and against other actors' performances. By "film technique" I mean the knowledge of the different kinds of playing required for close-ups, mid-shots and long-shots, the ability to make small actions dramatically effective, and the knowledge of the need for a kind of realism in performance which differs from the realism needed in the theatre.

An actor playing on the stage has to "project" himself across the footlights in such a way that the man in the front row of the stalls and the woman in the back row of the gallery both feel the emotional impact of the performance and can both hear and see what the actor is trying to do. To convey something subtle to the gallery and at the same time not to seem crude to the stalls requires technically very great control over voice and movement, some of which can be taught, but much of which results from experience as well as ability. From the actor's point of view the great difference between stage and film work is the absence of a live audience at the time of playing. Most actors in the theatre "play to the audience"—that is to say they vary their performance from day to day. This is seen most easily in comedy, for amusement in the theatre can quickly be gauged by the size and length of the laughs, which affect the "timing" of each performance. Acting in a film is done "cold," i.e., without an audience and the actor is entirely in the director's hands as far as timing goes. He also has little need to "project," because the microphone will, as a rule, be near to him, and will ensure that when the film reaches the cinema everyone will be able to hear him. And, of course, most important, his part is played in small sequences each lasting perhaps as little as half-a-minute, and not as a rule for more than two or three minutes.

In films another complicating factor is what is called "shooting out of sequence." This means that an actor's first scene shot in the studio may not be his first scene in the finished film. The reasons for this are mostly economic, because it is often financially profitable to film all the scenes on a particular part of the set, one after the other. The film director's job is to see that scene 128 is played in the right key to follow scene 127,

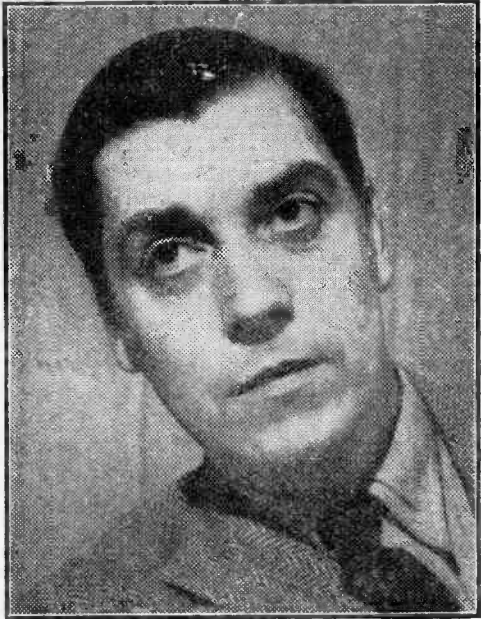

Royston Morley—Author of this article.

although the first may be shot weeks after the second. Many film actors show very great technical skill in judging just how to achieve this end without sacrificing performance.

This problem of performance out of sequence does not affect television, except in cases when certain scenes are filmed in advance of production and afterwards inserted in the live action of the show. A recent example of this was seen in the production of the French Resistance play "Men of Darkness." Many of the opening shots were filmed a month before transmission, partly because "ghost" effects possible in films but not in "live" television were required, and partly because live ammunition had to be fired from guns, which can only be safely done under film conditions.

Acting for television is intensive and exhausting from the actor's point of view. Plays are normally rehearsed for between two and three weeks, a much shorter period than is generally taken for rehearsing a West End stage-play. And, although it is true that the normal television play is about half-an-hour shorter than the average theatre play, a great deal of work has to be done very rapidly. A further complicating factor is that under present conditions producer and cast can only expect to rehearse in the studio on the day of transmission. All the rest of the rehearsal period takes place out of the studios, in an ordinary room with chalk marks (to scale) on the floor to represent walls and doors and fireplaces. This makes it necessary for the producer to be absolutely certain of all the details of the layout of the settings. "Be careful about that door"—one hears oneself saying to the actor—"the handle is downstage" (i.e., on the side of the door nearest to the camera)—"and it opens off" (i.e., away from the stage towards the wings). These details may sound trivial, but they are very important, because the actor must know in rehearsal which hand he will use to open the door with, and how he will move after he has shut it. If he only finds out

on the day of transmission, he will have to think about an apparently simple action, when his mind should be as free as possible to concentrate on more important points of acting. Similarly, the producer must be in a position to help the actor during rehearsal to get used to the idea of the cameras weaving in and out from close-up to long-shot, so that he won't be put off when they appear at the final rehearsal. Movements across the set must be slower than normal if a camera is going to "pan" (i.e., move horizontally from right to left or vice-versa to follow an actor's "cross"), because the cameraman needs time to move his camera-head smoothly and to adjust a focus to a moving object. This applies to what are called "sits" and "rises." "Get up slowly," says the producer. "I want to hold you in close-up all the time." And the actor makes a mental note to remember and at the same time to fit his lines to match a movement slower than nature.

Sound

Then there are the complications of sound. In television the microphone is movable, and is held on the end of an arrangement like a fishing-rod, able to move vertically or horizontally, to extend and retract. In close-ups, it can be within inches of the actor, and he can whisper and be audible; or in long-shots it may be several feet away to be out of shot, and he must raise his voice without necessarily appearing to do so. This brings us near to another influence on both television acting and production—namely, sound-broadcasting.

Radio producers and actors have worked out a highly-skilled technique for conveying differences of perspective in sound only, mostly controlled by the relative position of the actor and microphone. A radio actress like Miss Gladys Young is an expert in knowing exactly how to match performance and voice to the microphone to get the most subtle nuances of expression. Her virtuosity in this direction was well shown recently in "Corinth House," her first television performance, when she used her voice with telling effect. As producer, it was my job to help her to realise in rehearsal just where the television movable microphone would be, and during the transmission to see that it was there.

Close-ups

It is the size of the screen on the receiver that conditions picture-composition in television. The standard shot on the screen is the close-up, when the viewer sees the faces only of the actors. This allows great subtlety of facial expression in playing. A small movement of the eyes is as telling emotionally as a big movement of the body on the stage. Recently, Miss Catherine Lacey gave an object lesson (as Mrs. Solness in Ibsen's "The Master Builder") in just how much effect can be gained from expressive use of eyes as well as of voice and body. It is also necessary for actors to learn to work very close together for television close-ups. The wide-angle lens used on studio cameras has the effect of making a distance of 6in. or 8in. between two faces appear quite a natural distance. This alone requires a great deal of rehearsal, because neither on the stage nor in films do actors have to work so close together.

To the performer, a television studio looks very like a film studio. Only technicians are on the set, the lights are many and strong, and are constantly adjusted during rehearsal and sometimes moved during transmission, either to get a special effect or to improve a picture. The cameras silently move to a prearranged plan very carefully worked out and scripted in advance by the producer—who in British television is also the director. But there is one enormous difference for the actor who

is used to filming. There is no chance of a "re-take." Once the play has started, it continues to the end. Only a technical breakdown of equipment—and these breakdowns will eventually become as unusual in television as they are in sound broadcasting—can stop the show. If an actor "dries"—i.e. forgets his lines—he must take a prompt as he would in the theatre, and continue with his performance. It is the job of one of the play's stage-managers to act as prompter, moving in the studio during the action of the play to be beside and a little behind whatever camera is "on transmission." Prompting in television is highly skilled work and the prompter must know each individual actor's performance intimately, must mark just where pauses in the lines occur and memorise intonations and acting methods of conveying subtleties of expression. Nothing is worse than an unwanted "prompt" during an actor's pause between two words or lines—except the lack of a prompt when it is needed. A good prompter gives an actor a feeling of confidence, and rarely needs to speak. The other television stage-manager is responsible for what are called "properties" and their placing and positioning. The distance in the studio between (for example) the chair and the settee must be exactly what it has been in the rehearsal room, and the actor must know and feel certain that there will be cigarettes in the box on the table when he opens it, and that the matches are there and easy to strike. Similarly, the butler waiting to make an entrance with a tray of six glasses and two decanters must find the tray set out ready for him, in the right place and at the right time. Again, confidence in the stage-managers' efficiency is very important to avoid last-minute panics and "stuffing" of lines.

Studio-manager

In the studio the two stage-managers are supervised by the studio-manager, who looks after everything on the floor, i.e. the whole studio. Like the technicians, he wears headphones connected to the producer's microphone. His job is most like that of the gun position officer in a battery of artillery. The producer is forward at the observation-point, directing the "fire" of the cameras from a cubicle where he can see the resultant pictures, while the studio-manager passes on orders where necessary and is in charge of the whole "gun-position." A good studio-manager can be invaluable to the actor, in smoothing difficulties away, and calming excitement at moments of crisis.

Of course, all actors differ in the way they react to playing in television. But when I was writing this article I went round to see one of our most successful stars of theatre, films and television—Mr. Roger Livesey. He said that obviously the chance to play very quietly and to make small movements of face and expression tell, was pleasant and exciting. "It's when the camera gets really close to me," he said, "that I begin to feel that I have the chance to make my performance really come over. Then I know that for a little while I don't have to worry about my next move or to concentrate on getting to the right place for shots from another angle. While the camera is really close to me I can try to get inside the part and make the viewers see those subtle aspects of performance which can be most effective dramatically." I believe that most actors would agree with this, and perhaps this approach has made so many viewers feel that Roger Livesey doesn't ever seem to be acting—he *is* the character he is playing.

All producers spend their lives learning their job, and I in particular have learnt nearly all I know by working with players like Roger Livesey.

A Complete Range of Television Components

Line and Frame Scanning Assemblies.
Focus Coil and P.M. Units.
Line and Frame Output Transformers.
Line and Frame Oscillator Transformers.
Combined Line Output Transformers and E.H.T. Generators.

Width Control.

Video Correction Chokes.

Filament Transformers, E.H.T. Transformers and Smoothing Chokes.

All components are specified for the Electronic Engineering Home Televisor and the range includes components suitable for use in the Viewmaster and all of the Popular Home Constructor Sets.

ALLEN COMPONENTS LTD.

1, Shrewsbury Road, Stonebridge, London, N.W.10

Telephone: WILLESDEN 3675-4731

COMMAND PERFORMANCE

from your television receiver with a G.S.V. long-range aerial array (Prov. Pat.), which combines high forward gain with adequate bandwidth for good definition, thus ensuring the utmost fidelity of reproduction of which the set is capable.

The high front-to-side and front-to-back ratios of these aerials, which are similarly constructed to our transmitting arrays installed throughout the world, not only provide maximum signal pick-up, but also secure against interference from an unwanted direction.

The TVFL beam will ensure good reception in most locations some 200 miles from the transmitter, whilst the TVTL and TVRL arrays are designed for fringe-area reception, or use in nearer districts of low field-strength. A full range of standard types is also available for local reception, and all models are available for either London or Midlands frequency.

TVFL	Folded dipole, reflector and two directors with 10ft. mast and stayed boom ...	£7 5 0
TVTL	Folded dipole, reflector and director, complete with 6ft. mast ...	£6 0 0
TVRL	Folded dipole and reflector, 6ft. mast ...	£5 0 0
TVH	Standard H.O.25 spacing, with 10ft. mast	£5 1 0
TVG	Ground plane for roof-space mounting	£1 17 6
TVD	Standard half-wave dipole, various fixings	£1 17 6

The above prices are inclusive of packing and carriage; our technical staff is pleased to advise upon aerials for all frequencies and applications.

G.S.V. (MARINE & COMMERCIAL) LTD.,

395, HIGH STREET, CHATHAM, KENT

Chatham 3253/4



TELEVISION RECEIVERS SCANNING AND FOCUS COILS

P.M. FOCUS UNITS

5/8 kv. R.F., E.H.T. UNITS

E.H.T. & OUTPUT TRANSFORMERS

Technical Publications post free.

"TELEVISION CIRCUITS" a booklet compiled for the Constructor, post free 1/6

HAYNES RADIO Ltd.,

Queensway, Enfield, Middlesex.

"ADCOLA" SOLDERING INSTRUMENTS

Reg. Trade Mark



Regd. Design No. 860302

Designed for Wireless and Television Assembly SUPPLIED FOR ALL VOLT RANGES FROM 617v. to 230/50v. The three Adcola Models covering the requirements of the Television, Telecommunication and Radar Engineers assure thorough jointing.

3/8 in. dia. Bit. Standard Model ... 22/6

1/2 in. dia. Bit. Standard Model ... 25/-

3/8 in. dia. Detachable Bit ... 30/-

Patented in England and Abroad.

Sole Manufacturers:

ADCOLA PRODUCTS LIMITED

ALLIANCE HOUSE, CAXTON STREET, WESTMINSTER, LONDON, S.W.1.

Tele.: MACaulay 4272

LAWRENCES

NEW SURPLUS VALVES, FULLY GUARANTEED

At 2/9. 6H6. 7193. EA50. D1. LD210. LP220. SP41: At 4/-. 6SH7. FM2. FB34. 961: At 5/-. 2X2. 2C2A. 6J5GT. 6K7G. 6SL7. 7V7. 12A6. 12C8. 12AH7. 12J5. 11SH7. 12SK7. 12SL7. 12SG7. 12SH7. 12SJ7. 28D7. 713A. 865. 956. 9006. P61. SP61. 8D2. V872: At 6/6. 3Q5GT. 5P4. 5U4G. 5Y3G. 5Z3. 5Z4M. 6C5. 6B8. 6C6G. 6J5. 6J5GT. 6K6. 6K7GT. 6Q7GT. 6SK7. 6SJ7. 6SN7. 6SQ7. 6V6GT. 6V6G. 6S5GT. 6Y6G. 807. 957. 9001. 9002. 9003. EBC35. EF36. EF50. EC52. AD5. RL37. V570. V176A. VU111: At 7/6. 1F5. 3E25. 6AG7. 6AG5. 6AG7. 6B4. 6C4. 6P6. 6F7. 6J7. 6K7. 6K8. 6L7. 6N7. 6SA7. 6SFS. 6SG7. 6V6M. 12K8. 25L6. VR105/30. VR150/30. 9D6. PEN46. 72. 73. 83. 2050. VR136. EF39. EF54. CV66. ECH35. 1625: At 10/-. 6AK5. 6L6. 717A. 6J6. 1616: At 15/-. 832. 866A. 724A. 1B24. 3C24: At 25/-. 2AP1. 446A. 8025: At 27/6. 931A. 5F7. 8020: At 35/-. 115B. 805. VCR37. Two or more valves post free, otherwise please add 6d.

61, BYROM STREET, LIVERPOOL, 3.

TELEVISION COMPONENTS

FULL RANGE IN STOCK FOR LONDON AND MIDLANDS VERSION OF VIEW MASTER AND ELECTRONIC ENGINEER TELEVISORS

Instructional Envelope, Circuit, 7 Plans with Point-to-Point Diagrams—VIEW MASTER, 5/-
Instructional Book and Plans for Electronic Engineer Home-built Televisor ... 4/6

With PRICE LISTS

RETURN OF POST SERVICE

COVENTRY RADIO

189, DUNSTABLE ROAD, LUTON, BEDS.

Correspondence

The Editor does not necessarily agree with the opinions expressed by his correspondents. All letters must be accompanied by the name and address of the sender (not necessarily for publication).

E.H.T. FOR VCR97

SIR,—In reference to readers' queries on the polarity of the output in Fig. 3 of "E.H.T. for the VCR97," it is a fact that the indication is incorrect.

Re-drawn as below, the circuit will supply a positive voltage.

The 1 megohm lead was inserted purely as a stabiliser, to prevent a voltage jump if the normal lead is removed while the supply is still switched on.

The unit actually shown in Fig. 3, May issue, was used with a tap point at the "hot" end of the 100 k-ohms for biasing purposes, and it is evident the two drawings were switched over inadvertently.—T. W. DRESSER (Bradford).

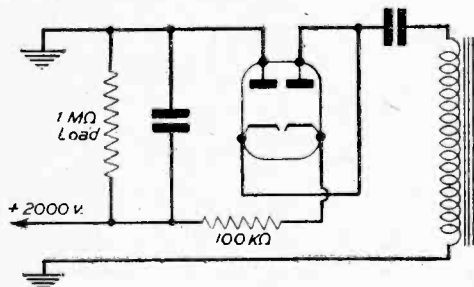

Revised diagram of the Fig. 3 circuit on p. 64 of the May issue.

CLEANING VALVEHOLDERS

SIR,—Under "Stability Aids," your June correspondent in his penultimate paragraph says: "Do not attempt to clean the valvholder with either trichloroethylene or carbon tetrachloride, as this will soften the metal which will lose its springiness, besides making it difficult to insert the valve without damage."

From inquiries so far pursued with metallurgists and other scientific people, I am assured that neither "trichloro" nor "carbon-tet." have any softening or hardening effect on either silver, bronze, copper, beryllium or ceramics.

It is felt that many readers would be interested to know if there is any confirmation of your reader's suggestion.—NEILSON HANCOCK (Surrey).

A FAULT CURED

SIR,—I thought you would like to know (if only to help other readers) that the dark shadow on the right hand of my mask has been cured, through following your suggestions and adjusting the focusing unit on all the screws.

To do this I had to move the bracket which carries the unit—forward, and screw out all the screws until the shadow disappeared.

Previously I had adjusted the screws until they would go no further, but by pushing the bracket forward I was able to unscrew and readjust.

Many thanks again for your valuable help, and please be encouraged that your counsel has proved successful.—J. CHAMBERS (Bolton).

USING THE VCR97

SIR,—After many months of experimenting with the VCR97 as a picture tube, with the object of getting as near perfect a picture as is possible with electro static deflection, I have achieved, not without the help of your excellent journal, some measure of success.

The final object was to obtain a picture of sufficient quality to warrant magnification, as the actual size is really too small for comfortable viewing.

I found that with 2.5 kV and 500 v. on the tube and time base respectively, occupied full scanning space but that the lines or rather the space between them was visible without the lens. With the lens the picture was increased to about double its size with some loss of light but the space between the lines was, of course, also increased, reducing the definition for close viewing.

By reducing the time-base voltage until there was virtually no space between the lines, the picture brilliance was almost doubled and even with the lens in position picture quality, definition and general brilliance were maintained to a marked degree even upon close inspection.—E. S. GURNEY (Cheltenham).

SIR,—I have been a close follower of the VCR97 correspondence over the past months and perhaps my experiences and experiments based on this correspondence may be of interest and use to new entrants to the television field.

E.H.T. (Final anode volts on load).—1,000 volts gives reasonable picture, using single valve T.B.s. Slight trapezium distortion and contrast rather shallow; 2,200 volts needs 2-valve T.B.s, but focus, brilliance and contrast are good enough for viewing in lighted room with screen shielded. Trapezium distortion nil.

Modulation.—2,200 volts requires approximately 40 volts signal for full modulation. This is obtained in writer's locality.

Time-Bases.—Miller integrators (paraphase amplifiers). Line linearity good, perfected by 600 pF from amplifier grid to earth. Frame linearity not perfect, but difficult to trace fault on picture (480 volts H.T. supply).

Video.—Positive going picture requires bias resistor lower than normal; 60 ohms approx. correct, and increases amplification of stage and power handling capacity.

Interlace.—Although flyback interlaced, and half-line was visible at top and bottom of picture, interlacing was not taking place. Irregular frame waveform apparently to blame. Much improved by condenser (.005 to .02μF) from oscillator grid to earth.

Focus.—Mr. Ward's trouble may be due to external fields as speaker and transformer fields affect beam up to about 3ft. from tube. Interlacing also appears to be faulty as lines are scarcely distinguishable on an interlaced picture 4in. high (approximately 96 lines per inch).

A shadow exists on line on my tube, but is of no consequence. A fault as yet uncured is frequency drift on line. If locked hard on switching on drift is gradual until, after two hours, line crumples to right. No voltage change is apparent and no overheating takes place. Any information from readers who have cured this will be appreciated.—B. SHATWELL (Oldham).

Reception at Extreme Ranges

Pre-amplifiers, Noise and Aerials are Discussed Here

By DONALD W. THOMASSON, A.M.Brit.I.R.E.

IT is often emphasised that television reception is only possible within fifty miles or so of a transmitter, but enthusiasts persist in their attempts to pick up signals at much greater ranges. The results they obtain may be divided into two classes: Freak reception, which depends mainly on favourable propagation conditions, and genuine long-distance reception at programme quality.

Freak reception is nothing new. Within a few weeks of the opening of the high-definition service from Alexandra Palace in 1936, the signals were being received in South Africa, six thousand miles away. Experiments have been continued at Cape Town since the war, and two standard table-model receivers have been used since October, 1948, transmissions from London and Paris being picked up on many occasions.

This illustrates the essential quality of freak reception. When the signal is good, no special apparatus is needed. When the signal is bad, no receiver can improve it. The best results noted in Cape Town have been grouped near the Equinoxes, in March and October, when the signal strength there may be as high as it is in "fringe" areas in this country.

The reception periods are comparatively brief, however, a time of twenty minutes being typical for good conditions. The picture is frequently hidden by violent bursts of interference, lasting for between a few seconds and half a minute. These may mask even the local interference, "blocking" the receiver so that it becomes completely dead for a few moments after the interference ceases. It can be imagined that such reception is of little use from the "programme value" point of view.

Range Extension

Experiments in freak reception have been condemned as harmful to the proper development of television, but there can be no doubt regarding the practical value of genuine range extension work. Even when all the new television transmitters at present planned have been built and put into service, there will still be a large part of Britain outside the combined service areas.

Range extension experiments are proving that it may be possible to obtain reception in these areas by using special techniques. The same techniques may also be valuable in "difficult" areas, where the signal strength is unexpectedly low.

One manufacturer has already produced a special receiver for "fringe area" use, the average reception range for full programme quality being increased to about 100 miles. Shortly before its presentation at Radiolympia, 1949, this receiver was demonstrated in public at a distance of 160 miles from Alexandra Palace. The results were variable, but full programme quality was obtained during the whole of two evening transmissions, in spite of severe interference.

An examination of the circuit of this receiver reveals that most of the stages follow normal practice. The main differences are in the first R.F. stage and in the synchronising circuits, the basic noise level being kept low by careful R.F. design, and the synchronising action being unusually immune to the effects of interference.

It is interesting to note that a "raster" can be held when the picture is barely visible.

The value of such a receiver can be illustrated by the remark of a man who spent a considerable time watching the demonstration. He commented that the results were better than he could obtain at his home, within forty miles of London.

The methods used to obtain an extended reception range are mostly of a simple nature. Once the require-

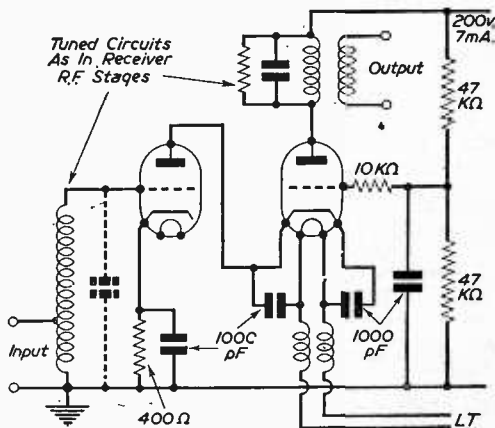

Fig. 1.—A cascade pre-amplifier

ments are understood, many possibilities will suggest themselves.

First-stage Noise

One of the most serious limitations of reception range is imposed by the noise generated in the first R.F. stage. A typical R.F. pentode designed for television use may develop internal noise equivalent to an input of $6 \mu\text{v}$, and this sets the minimum useful signal level in the region of $50\text{-}60 \mu\text{v}$.

The noise is proportional to the R.F. bandwidth, and the above figure applies to the normal full bandwidth for single sideband reception. It could be reduced to a considerable degree by cutting down the bandwidth, but this lowers the horizontal definition of the picture, and should only be adopted as a last resort.

The best solution is to fit a pre-amplifier having a low noise level. It is a mistake to suppose that such a pre-amplifier should have a high gain. Most receivers have a maximum sensitivity giving full picture modulation with an input of $50\text{-}100 \mu\text{v}$, and excessive pre-amplifier gain will only mean that the receiver gain control has to be set back.

Suppose the noise level in the first stage of the receiver is $10 \mu\text{v}$, and the input sensitivity is $100 \mu\text{v}$. If the pre-amplifier first-stage noise is $3 \mu\text{v}$, it will be pointless to give the pre-amplifier a gain of more than three or four times. The gain might be increased to double

this figure with advantage if the later stages of the receiver produce visible noise patterns at maximum gain.

The main requirement for the pre-amplifier is low noise, and this indicates that a triode might be used with

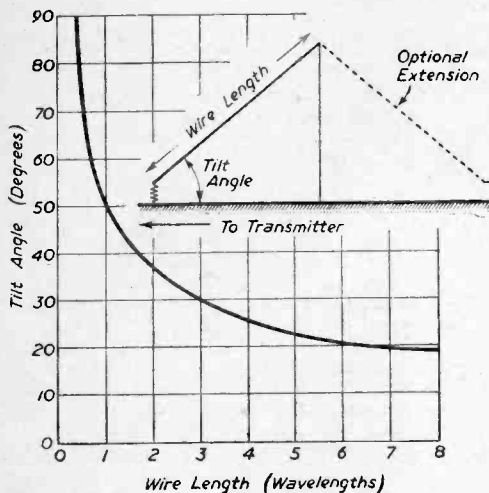

Fig. 2.—Optimum tilt for rhombic aerial elements

advantage. To overcome the usual objections to the use of a triode at R.F., the circuit shown in Fig. 1 can be used.

This circuit is known as the "Cascade" and can be regarded as a normal anode-coupled amplifier feeding into a grounded-grid stage. The input impedance of the grounded-grid stage is very low, and the anode voltage of the main amplifier remains almost constant. The damping due to "Miller Effect" is therefore very small, and the performance in this respect is rather better than that of an average pentode.

The anode current variation is equal to the input voltage variation multiplied by the mutual conductance of the main amplifier valve. The whole of this variation passes through the load circuit, and the voltage gain is thus the load impedance multiplied by the mutual conductance of the amplifier valve. To be strictly accurate, the load impedance should be taken as the actual load in parallel with the anode impedance of the grounded-grid valve, but the difference is usually small.

Among the more important precautions to be taken with this stage may be mentioned the decoupling of the heater leads to the grounded-grid valve. The cathode of this valve is "live" with respect to R.F. and the capacitive coupling between the cathode and the heater would cause trouble if the heater were connected directly to earth. This precludes the use of a double triode.

Various valves have been used in this circuit. The best results are obtained with valves having a high mutual conductance, but 6J5 triodes have been used with success.

Feeder Loss

The loss due to the feeder cable from the aerial should normally be negligible, but some types of aerial fail to match the coaxial cable properly, and the loss can

then be serious. It can be turned to good account, however, in the reduction of first stage noise when the mis-match is unavoidable.

This is accomplished by putting the pre-amplifier at the aerial end of the feeder. Both signal and noise are then attenuated together before reaching the set, but the signal-to-noise ratio is unaltered, and is as good as it would be if the whole of the signal from the aerial reached the input to the set.

This scheme is only worth while when the feeder loss is appreciable. It is generally better to match the feeder where possible, and the pre-amplifier can then be kept near the set. The problem of mounting the unit near the aerial is in itself a strong inducement to avoid the method where possible.

Interference

When the first stage and general receiver noise have been cut to a minimum, there still remains the problem of interference pick-up. The interference does not arrive solely by way of the aerial. It arrives via power leads, and can be picked up directly by the R.F., I.F., or video stages of the set.

Proper screening is essential, and this applies to the video stages as much as to the R.F. and I.F. The video circuits deal with frequencies covering the long and medium broadcast bands, and interference which affects those bands can also affect the video section of a television receiver. Mains lead suppressors should take this into account.

The demonstration at 160 miles range, mentioned above, was given in connection with an exhibition held under canvas. Among the interference sources noted as causing trouble were several thousand feet of neon tubing, fluorescent lighting, electric motors, and flashing signs. After mains suppressors for the broadcast, I.F., and R.F. ranges had been fitted, only two items continued to give trouble. These were a flashing neon sign switched on the high-tension side of the transformer, which sounded

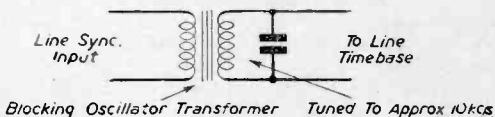
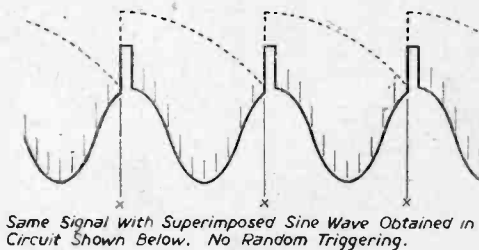
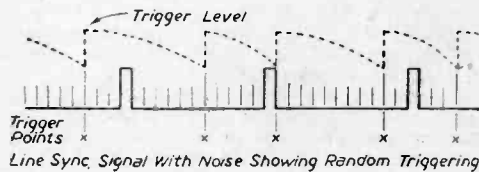

Fig. 3.—A method of improving line sync action.

like a railway engine on the television sound, and a small electric motor driving an animated doll. Both these were picked up at a point half a mile away, so it is not surprising that suppression could not deal with them.

When this stage was reached, further improvement could only be obtained by modifications to the aerial. The results were interesting, and not a little surprising.

Aerials

In order to be prepared for all emergencies, the demonstrators had made provision for a tower of metal scaffolding which gave aerial heights up to 90ft. Preliminary tests showed that the signal strength obtained with a plain H aerial at about 45 ft. was as good as that obtained with more complex arrays at a higher level. The advantage gained by the height was apparently offset by greater feeder loss.

These tests had been made with the interference sources switched off, however, and it was found that the interference pick-up could be reduced to a considerable degree by raising the aerial to the full 90ft. A further reduction was obtained by using a double-H aerial consisting of two H sections placed side by side at a distance of about a quarter of a wavelength. The beam width of this aerial was noticeably narrower than that of the single H, and some of the more remote interference sources were probably suppressed by this.

It must be emphasised that the great aerial height was only made necessary by the high interference level. This is perhaps just as well. Apart from the problems of space for such a tower, climbing about on a slender pinnacle of swaying scaffolding is a pastime enjoyed only by a select few. It is extremely difficult to carry out serious work on the aerial, when elbows and ankles are fully occupied with the task of hanging on.

For domestic use, normal chimney-top height should be enough. The Sutton Coldfield signals are being received in Exeter (150 miles) with a single dipole at a height of about 25ft and an ex-surplus conversion receiver, with no pre-amplifier.

It is difficult to be dogmatic about the best type of aerial, since this depends on the locality and the available space. A good deal of experiment is worth while, and all possible kinds of array should be tried. One of the best in many cases is the quarter-rhombic, which consists of a sloping wire placed with the lower end pointing towards the transmitter, this end being fixed near to the ground, and earthed through an 80-ohm resistance. The angle between the wire and the ground depends on the length of the wire, as shown in Fig. 2.

The object of the aerial should always be kept in mind; it must pick up the greatest possible signal, and the minimum possible interference.

Synchronising Circuits

When everything possible has been done to cut down noise and interference, it is still possible to improve the results by making the scanning action less sensitive to random triggering. The broad scheme is to emphasise the regular scanning pulses with respect to the interference.

Little need be done regarding the frame sync circuit, as a rule, as this does not react readily to single pulses. The line sync is much more sensitive. The simplest remedy is the connection of a tuned circuit resonating at 10,125 c/s. across the line sync feed to the time base. This has the effect illustrated in Fig. 3. The pulses drive the circuit, producing a sine wave voltage which "lifts" the pulses to a higher level. The circuit should

actually be tuned for resonance at a frequency lower than the line frequency, so that the voltage rises sharply before the sync pulse, as shown.

A more ambitious version consists of a tuned amplifier which extracts the fundamental frequency from the line sync signal, followed by a squaring amplifier which produces a 10,125 c/s. square wave. This is differentiated and used in the normal manner to synchronise the time base. Here again, the resonant frequency must be mistuned slightly for best results. The circuit only passes the regular sync pulse signal, and completely excludes noise and interference pulses.

Fading

The last point to be covered is the fading which is the main cause of trouble at extreme ranges. The mean signal strength is often high enough to give excellent pictures, but the minimum is very low, and the picture is lost completely.

While no universal remedy can be suggested, it may be noted that very promising results have been obtained with aerials having special vertical directivity characteristics. These are used to minimise the pick-up from sky-wave signals, and give a greater sensitivity in the direction of arrival of the ground wave.

When fading does occur, the contrast control requires constant adjustment. It would be useful if A.V.C. could be applied to television receivers, but this is generally regarded as impossible. Current experimental work on the subject suggests that A.V.C. might be obtained by "sampling" the video waveform during the frame scan flyback, when only the sync pulses are present, but the circuit is fairly complex.

A more popular solution involves the use of a control panel on an extension lead, the contrast, brilliance, and line frequency controls being mounted on the panel. Adjustments can then be made from the viewing position whenever they become necessary.

Conclusion

This brief account of some methods and experiences relating to long-distance television is no more than a bare introduction to the subject. There are few branches of radio or television study which offer greater scope for experiment, and few give more rewarding results.

The work is necessarily tedious, since much of it is in the nature of "trial and error" experiment, but there is certainly no lack of variety in the subject.

JOIN THE PRACTICAL GROUP

Edited by F. J. Camm

PRACTICAL ENGINEERING, 4d.
Every Friday.

For Engineers, Mechanics, Designers and
Works Managers.

PRACTICAL MECHANICS, 9d.
Every Month.

Devoted to Mechanics, Science and Invention.

PRACTICAL WIRELESS, 9d.
Every Month.

SUPREME RADIO, 7466, Romford Road, Manor Park, E13 (Tel. ILF 1260).—P.M. Focus Units for Mullars tubes, 15/- ea.; for Triodes, 16/- ea.; V.C.R.97 Tubes for television, 35/-; Black Masks for same, 3/6 ea.; latest type Magnifier for above, 27/- ea.; EF50 Valves, new, boxed, 7/6 ea.; EF50 Valve Holders, Ceramic, 6d. ea.; 5/6 doz.; Retaining Rings for same, 9d. ea.; 8/ doz.; screw type, EA50 Valves and D.1., new, 3/- ea.; Valve Holders, bakelite type, for same, 6d. ea.; Co-Ax Cable, 80 ohms, 8d. yd., as above, but 50 ohms 6d. per yd.; 5/6 doz. vds.; Aerial Plug and Socket for same. 1/-; Twin-balanced Feeder, 5d. yd.; 4/6 doz. vds.; screened as above, 1/- yd.; 11/- doz. vds.; Fly-back type Line Transformer, 5.5 k/v, output, 22/6; 2.5 k/v E.H.T., with 4v 1.5 amp., and 4v 2 amp C.T., 27/6 ea.; Tapped Primary, 0.1 MFD, 2.5 k/v Insulated Case Cond., 3/6 ea.; 8m.m. Aladdin Coil Formers with cores, 8d. ea.; 6m.m. with cores, 6d. ea.; Wound Coils for London E.E. Televisor, 1/6 ea.; Choke 1/-. All parts in stock for Home Constructor Televisors. Comprehensive range of 1 watt and 1/2 watt Resistors always in stock 3d. ea.; Mica Cond., 40PF, 50, 60, 65, 305, 307, 500, 530, 570, 590, 700, 1,800 and 4,550 PF, all at 2/- doz., or ass. Terms: C.W.O.: no C.O.D. Send 6d. extra for postage orders under 45s. 24d. S.A.E. all enquiries and lists.

CRESCENT RADIO (Dept. A), 233, High Rd., Wood Green, N.22 (BOW 3206).—Huge range of Television and Radio Components and Valves in stock at competitive prices. Resistors: 1/2 watt, 2d. each, 1/9 doz.; 1/4 watt, 4d. each, 3/ doz.; 1 watt, 6d. each, 4/6 doz.; Condensers: 2pf to 3,300pf., .0004 mfd to 25 mfd, 350v, 500v, .000v, 6d. each, 4/6 doz.; 5 mfd 350v, 9d. each, 500v 1/3 each. Valves: OM4, OM6, OM10, 6V6, 6X5, 7/6 each; large range in stock. Viewmaster Resistor Kits, 11/9 including postage. Wirewound Potentiometers, values as specified, 3/- each. Condenser Kits and Rectifier Kits in stock. Volume Controls with switch, 4/6 each. Volume Controls, less switch, 2/6 and 1/6.

TELEVISION, RADIO, AMPLIFIERS. Repairs, modifications; special equipment built to order; home-built receivers aligned and tested; large stocks of high-quality Components, Valves, etc.; Transformers to spec. Chassis drilled and punched. **BERNARDS, Radio Engineers, 12, Chelverton Road, Putney, London, S.W.15 (PUTney 7538.)**

PRACTICAL WIRELESS TELEVISOR, Aladdin Formers, 10d. ea.; Tag Ring, 24d.; Set of Coils, London or Birmingham, 16/6; Chassis, 24s; Mains Transformer, 350-0-350v 250ma 5v 2a, 6/3v 4a 6/3v 4a 68/6. S.A.E. list. **R. F. SHILTON, 19, Clarendon Road, Salisbury, Wilts.**

BEL.—For all Tele. Coils: London Type EE 15/-, V/M 19/6, PW 16/6, WW 48/-; Midland Type EE 18/6, V/M 19/6, PW 19/6, WW S'het. 52/6, WW, EE, PW Chassis. Special Coils to order. Trade supplied. **BEL SOUND PRODUCTS, Marlborough Yard, Archway, N.19.**

"VIEW - MASTER" ? "Electronic Engineering" ? Then **JAMES H. MARTIN & CO.**, of course, we are specialists in TV, 58, Capworth St., London, E.10. Stamp for list.

6SH7 Ideal T/V H.P. Valve 5/-, 6H6 3/-; I/Oct. Holders (for above), 5/- doz.; Iron Cores, 4in. threaded, 1/- doz.; Output Trans. Pen. 3/6. New Goods. **RADIO SERVICE, 131, Elgin Rd., Ilford, Essex.**

T.V. DI-POLE INSULATORS, in moulded bakelite, ft 4in. elements and 1in. boom, 5/- each. C.W.O. **M. & B. RADIO, 120, Holt Rd., Liverpool, 7.**

RATES: 3/- per line or part thereof, average five words to line, minimum 2 lines. Box No. 6d. extra. Advertisements must be prepaid and addressed to Advertising Manager, "Practical Television," Tower House, Southampton St., Strand, London, W.C.2.

"RETURN OF POST" Component Service.—Valves, guaranteed brand new, boxed, 6V6, 6K7, 6K8, 6Q7, 5Z4, 5U4, 6N7, 6J7, 6F6, 6C5, 807, VU111, KTW61, EBC33, EF39, EK32, 6AC7, 6L6, all at 6/3 each; 154, 174, 155, 1R5, 354, all at 7/3; Reboxed, perfect, VR91, 6/-; New/boxed, VR91, 6/8 ohms, Co-Ax, 10d. yd. EF50 Holders, 6d.; Int. Oct. (amph.) Holders, 6d.; B7G type, 9d. P.M. Speakers, 3in. 11/-, 3 1/2in. 12/6, 5in. 10/6, 6in. 11/6, 8in. 12/6, 10in. 16/6. Gold finish Metal Grille, 4/- sq. ft. Mains Trans., 350-350, 6v, 5v, 4v, 80 m.a., 18/6. Vcontrols, 25K, 50K, 1/4, 1 meg., L/sw., 2/6, W/sw., 3/9. Condensers, Sprague, 1, 350, 6d.; 8mfd, 500, 2/3; 10mfd, 500v, 3/3. Full range in stock. New list available. Id. stamp. **"RADIO UNLIMITED," Elm Road, London, E.17.**

A PORTABLE TELEVISOR.—Bradbooks proudly announce their second "first-ever" publication by Edwin N. Bradley. The result of months of experiment. A Portable Television gives COMPLETE information for building a 3in. or 6in. TV receiver, the 3in. prototype measuring only 15in. x 11in. x 7in. with powerpack, tube, speaker, etc., all self-contained. Not a hashed-up conversion job, but a tested new design with frame linearising and other new features. Order your copy, 56 pp., price 3/- (3/2 post free), from **BRADBOOKS, Sennen, Penzance, Cornwall.** Don't forget to order "Personal Portables," too, a mine of information, at 2/8, post free.

T.V. AERIALS.—Midland H type with 12ft. mast, £3/10/-; ditto, 8ft., £2/17/6; 3-element type, £4/15/-; double H or 5-element, £6/6/-. All complete with brackets, lashings, bolts, etc. C.W.O. Carriage paid. **R.R.S., 395, Badsley Moor Lane, Rotherham.**

TELEVISION AERIAL COMPONENTS. Alloy Tube, drawn in AW.10.C.; Mast-head Brackets, alloy and wood masts, Chimney Brackets, Corner Plates and Lashing Cable, J. Strainer Bolts, U Bolts, etc. **WALTER CRANE, Electrical Engineers, Wakefield.** (Telephone: 2172.)

VIEWMASTER Components supplied from stock. Send for special list covering London and Birmingham models. **M. WATTS & CO., 8, Baker Street, Weybridge, Surrey.**

TELEVISION COMPONENTS
FOR THE
"Practical Wireless"
VIEWMASTER AND E. E. TELEVISORS
IN STOCK

Price Lists of specified and alternative components for P.W. and E.E. T.V. available
Prompt Postal Service

J. T. FILMER
MAYPOLE ESTATE, BEXLEY, KENT
TEL. Bexleyheath 7267

FRITH RADIOCRAFT, LTD., offer the finest TV parts service in the Midlands! Now available from stock.—Tallon packed-flat TV Cabinets; 9in. Table Viewmaster, £5/15/-; 12in. VM Console, £12/10/-; Elect. Eng. 12in. Console, £13/10/-; Whiteley 9in. Table VM, complete with mask, glass and engraved knobs, £6/17/6; Aluminised CRT's 9in. G.E.C. 6504 Flat end, £12/5/9; Standard CRT's 12in. CRM121, MW31/14C, £15/2/5; 9in. CRM92 MW22/14C, £11/6/10; White Masks, round or flat end, 12in. 21/6, 9in. 11/3, 6in. for VCR97 7/6; PM Focus Magnets, Elac R17 21/-, R20 22/6, R25 25/-; Plessey 72004, 72005, 19/6; Focus Coils: Denco 25/-, Allen 35/-; Scanning Coils: Denco 30/-, Allen 35/-; Plessey 25/6, "WV" 35/-; Line OP Transformers: Denco 27/-, Allen 35/-; EHT Transformers: Varley 4Kv 67/6, 5Kv 72/6, Woden 4Kv 65/-, 5Kv 72/6; Mains Transformers: Woden "EE" Potted 98/6, Varley "EE" 90/-; Chokes: Varley 5H 18/6, 10H 17/-; TV Coils: "EE" London 15/-, B'ham 17/6, "VM" London 20/-, B'ham 28/-; "S'het L or B 52/6; Aladdin Formers with cores, large 10d., small 7d.; BTH Crystal Diodes G1-C 11/3; STC HV Rectifiers H/4 200, 28/-; Eddystone S/stator 25+250F, 7/6; Reliance Controls TW/100/250/500/1k/2k/2.5k/5k/10k/25k/50k, 4/6; TW/100k, SG/150k, 2meg, 5/-; All above brand new, satisfaction guaranteed. Post free over £1. **FRITH RADIOCRAFT, LTD., 69-71, Church Gate, Leicester.** (Phone: 58927.)

EX-R.A.F. Pre-Amp 45 M/C, with diagram for conversion to sound and vision, local and fringe, 19/6; 01 x 4,000v., oil filled, 1 1/3; 50 assorted SII Mica 10/-; 50 assorted Res. 1 1/8; 15/6 Elect., 2/6; ex-Govt. Valves from 2/6. Send for latest "Cheapest List in England," **SUSSEX ELECTRONICS, LTD. (T.), Riley Road, Brighton, 7.**

HORIZONTAL TV Slot Aerials. Tested designs. Various types. Full drawings, 5/6. **STANWELLY, Kingsdown, Sevenoaks.**

SALE, Premier TV, less power pack, all new components, £10. Details: **CALVER, 129, Stradbroke Rd., Lowestoft.**

EDUCATIONAL

TELEVISION.—The Gothic Television School specialises solely in training in television. Principals: M.B.E., B.Sc., M.Brit.I.R.E., education committee members, etc. Courses assume no previous television knowledge and provide guaranteed training for Brit.I.R.E. and R.T.E.B. examinations. All tutors possess university degrees and/or corporate membership of professional institutions and are appointed individually to postal courses, students to ensure complete and thorough training. Numerous well-known companies have adopted the School's Basic Television Course as standard television training for their staffs. Moderate fees. Details from the Secretary, **GOTHIC TELEVISION SCHOOL, 13, North Ave., London, W.13.**

TELEVISION Servicing and Theoretical (postal) Courses at extremely moderate fees are available from the Institute of Practical Radio Engineers, either for study or as reading matter only. Syllabus, post free from the Secretary, **I.P.R.E., 20, Fairfield Road, London, N.8.**

MERCHANT NAVY and Air Radio, Day, Evening and "Radiocerts" Postal Instruction Apply. **THE RADIO OFFICER, The Wireless School, 21, Manor Gardens, Holloway, N.7.** (ARC. 3694.)

GEE BROS. RADIO

FOR LTD
QUALITY COMPONENTS &
SATISFACTION

0-100 Micro Ammeters, 2 1/2 in. dial (flush mounting), scaled as 0-1,500 vds. Brand new. Bargain, 20/- each.
12in. Magnetic C.R.T.s Type VCR140. Ex-Government, new For callers only, 25 each.
Heavy Duty 152 ohms at 2 amps Precision Variable Resistors (made by Renzi Holmes) Brand new, Bargain at 22/6 each.
Metal Rectifiers, Heavy Duty 24 v. at 12 amps. Brand new in metal containers. Only 40/- each.
Complete Heilmann Tool Kit, containing an assortment of Sleeves, oil and tool, only 17/6.
R7G Ceramic Valve, with skirt and screening can, 1/9.
Photo-electric Cells, type CMG22 Osram. Brand new, only 20/- each.
829B Twin Triode, 80/- each.
832 Ceramic Valveholders, used, 2/6 each.
2in. P.M. Loudspeakers, by Whiteley, 3 ohms, 15/-.
200-220 at 80 m.a. Mains Transformers. Drop-through type, 200-50 primary 50 cycles with 6.3 v at 3 amps and 5 v at 2 amps, only 18/6 each.
The famous G.P.20 Acos Micro-cell Pick-up, 23 11s. 5d.
Valves (all from ex-Government units) in good condition. EF50, EF39, EF36, EBC33, 6SN7, 6SC7, 6AC7, 6AB7, 2X2, 6V6GT, 5Z4, 6X5GT, RL18, 6J7 metal, 6F6, 12A6, 17A, 1S5, 1R5, S130, VR150/30, 6N7, VP23, ML4, 6P3C, EK32. Any of the above at 7/6 each or 84/- in dozen lots your selection. Terms: C.O.D., cash with order, or proforma. Please add 1/- extra for postage on orders under 20/-.

GEE BROS. RADIO LTD.
15, Little Newport St.
LONDON, W.C.2
GER 6794

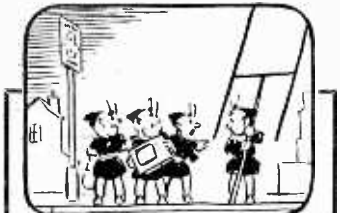

The "Fluxite Quins" at Work

"A fine sight we look in this queue,
When the bus comes, what'll we do?
This set to FLUXITE
Before broadcast to-night,
But why bring the aerial, too?"

See that **FLUXITE** is always by you—in the house—garage—workshop—wherever speedy soldering is needed. Used for over 40 years in Government works and by leading engineers and manufacturers. Of all ironmongers—in tins, 10d., 1/6 and 3/-.

The **FLUXITE GUN** puts **FLUXITE** where you want it by a simple pressure. Price 2/6, or filled 3/6.

FLUXITE

SIMPLIFIES ALL SOLDERING

Write for Book on the Art of "SOFT" Soldering and for Leaflets on CASE-HARDENING STEEL and TEMPERING TOOLS with **FLUXITE**. Price 1d. each.
FLUXITE Ltd., Dept. P.T.,
Bermondsey Street, London, S.E.1

Pre-Amplifier de Luxe. Consisting of power pack and two R.F.s. Built up and enclosed in case. £7-12-6, carr. paid.

Pre-Amplifier Transformer. Prim. 200/250 v. Sec. 230 v. at 30 mA. 6.3 v. at 1.5/2 amps., 19/6.

F35X. 350-0-350 v. at 250 mA., 6.3 v. 6 amps. 4v. 8 amps. 4 v. 3 amps. 0-2-6.3 v. 2 amps. Fully shrouded, 59/6.

FS160X. 350-0-350 v. 160 mA. 6.3 v. 6 amps. 6.3 v. 6 amps. 5 v. 3 amps. Fully shrouded, 37/6.

FS43X. 425-0-425 v. 250 mA. 6.3 v. 6 amps. 6.3 v. 6 amps. 5 v. 3 amps. Fully shrouded, 57/6.

FS50. 450-0-450 v. 250 mA. 6.3 v. 4 amps. C.T. 6.3 v. 2 amps. C.T. 5 v. 3 amps. Fully shrouded, 62/6.

F36. 250-0-250, v. 100 mA. 6.3 v. C.T. 6 amps. 5 v. 3 amps. Half shrouded, 25/9.

FS150. 350-0-350 v. 150 mA. 6.3 v. 2 amps. C.T. 6.3 v. 2 amps. C.T. 5 v. 3 amps. Fully shrouded, 28/9.

The above have inputs of 200/250 v.

H. ASHWORTH

676, Great Horton Road, Bradford, Yorks.

Tel.: Bradford 71916.

MIDLAND TELEVISION STRIPS 7 gns.

Superhet Television strip with R.F. stage, video band IF's, Video detector and Video amplifier. For Midland or London Vision service. Completely wired in and tested, 6 v. and 200/250 v. H.T. Post Free, 7 gns.

PYE T.R.F. VISION STRIPS 85/-
London 45 mc/s wide band TRF strip. Video amplifier, 7 valves in all, 6 v. and about 200 v. H.T. required, Post Free, 85/-.
Both the above strips will work with any Kit such as Viewmaster, Electronic Engineering, WW, Denco, etc. Denco High Gain 70/80 ohm input coils are used.

RADIOTELEPHONES COMPLETE 10 gns.

Portable Radiotelephones weight 9 lbs., telephone type, handset with batteries, etc., two-way conversation over 15 miles. Complete per pair of Transceivers, 10 gns.

ALL DRY BATTERIES 10/-

Special type 1.5 v., 90 v., 180 v. and 200 v. for any Radio or 50 set, normal price, 35/- each. Few only, 10/- plus postage. A.C./D.C. Amplifiers, Communication Receivers and Tape Recorders in Stock.

COLLINS RADIO
24 LILYVILLE ROAD, LONDON S.W.6. RENown 4178

CO-AXIAL CABLE (Brand New)

5 mm. Not Ex-Govt., 10d. yard. 3 Bank 10-way Ceramic Rotary Switches, Bargain, 8/6. E.F. 50 Screw-on Valve retainers and base, 8d. per pair. Hundreds of bargains. State your requirements.

D. J. CLARKE

2/4, Shortmead St., Bletchley, Beds.
Tel.: 2377.

RADIO EXCHANGE CO.

FRESH SUPPLIES!

Brand New 1355's. Huge new stocks of 1355's (which may have slightly soiled metal work due to long storage) enable us to offer these in ORIGINAL SEALED MAKERS' CRATES, complete with 11 valves. ONLY 55/- plus 7/6 carr.

RECEIVER TYPE 18—with four battery operated valves, and covering 6-9 Mc/s. This is a really fine little receiver. Complete with circuit, connecting data and batteries, 27/6.

PYE PLUGS and sockets—as used on 99% of ex-radar equipment. ONLY 6d. per pair.

POWER UNIT 19. A really "hefty" converter, providing 275v. at 110 mA, plus 540v. 40 mA from a rotary converter; a 275v. output vibrator pack is incorporated on the same chassis. 12 or 24 v. input makes this the ideal TV power unit for those without mains supplies. ONLY 12/6.

RADIO EXCHANGE CO.
9, CAULDWELL ST., BEDFORD

TELEVISION

SEND FOR FREE 176-PAGE BOOK!

The growth of Television offers unlimited scope to those Radio Engineers who have the foresight to become technically qualified. Full details of the easiest way to prepare at home on "NO PASS—NO FEE" terms for A.M.Brit.I.R.E., R.T.E.B., CERTIFICATE, etc., are given in our 176-page Handbook "Engineering Opportunities."

We guarantee

"NO PASS—NO FEE"

This valuable handbook also describes our up-to-date Television, Television Servicing and General Radio Diploma Courses, Electronic Engineering, etc. Send for a copy of this enlightening Guide to-day, mentioning the subject of interest. "ENGINEERING OPPORTUNITIES" will be sent to you FREE and without obligation.

BRITISH INSTITUTE OF ENGINEERING TECHNOLOGY
237, Shakespeare House,
17-19, Stratford Place, London, W.1

TELEVISION PICK-UPS AND REFLECTIONS

UNDERNEATH THE DIPOLE

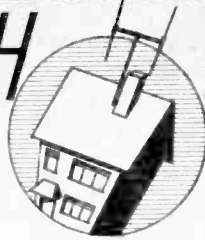

By Iconos

AERIAL HEIGHTS

CURIOS points crop up from time to time. In some instances, aerials of a complicated type have been erected in quite low positions. There may be instances where a comparatively low aerial situated in a back garden, screened from main road traffic by the house, will give far greater reduction in car interference than by any other means. Where the signal strength from the transmitter is reasonably high, this is a good arrangement, otherwise, the cheapest and most effective way to increase the signal is to have a really high mast with reflector, arranged if possible, to screen the dipole from the nearest road traffic.

IN THE YORKSHIRE DALES

RECEPTION of Sutton Coldfield in the higher parts of Liverpool is good and it is even better across the Mersey at New Brighton. Manchester district is good in parts, but subject to considerable local interference. Much more uneven, however, were the results obtained in the hilly country of South Yorkshire. It was interesting to note the aerials on houses high up on the sunny northern sides of the valleys around Hebden Bridge and their complete absence on the south and south-west sides. And dealers in these districts are being extremely cautious in dealing with television sales—and quite rightly so. They take the attitude that unsatisfactory results at this stage might discourage potential buyers at a later date, when a nearer television transmitter is in operation. Hell hath no fury like a woman scorned—but, it appears, the fury of a Yorkshireman who gets unsatisfactory results on his TV set runs her a good second. Reception in these dales is decidedly freak, in any case. Sometimes an odd trick of reflection from a metallic surface—such as a gas holder—gives two images, the reflected one being stronger than the direct pick-up. One type of aerial, often seen in the south, was conspicuous by its absence—the highly directional tilted-wire array, which has the most directional properties of all.

TV AND THE LAY PRESS

THE attitude of the Press to television is conditioned by the number of television licences. Many newspapers now devote special columns to television, quite separate from the radio notes. Mr. Marsland Gander, of the *Daily Telegraph*, was one of the first radio correspondents to devote considerable attention to television and his views on both the technical and artistic sides of TV are much more on the mark than some of his contemporaries. His "Radio Topics" have not yet divided into two sections—though he occasionally devotes the whole of his column to TV. The *Daily Mail* has suddenly started to put heavy emphasis on television—and has even launched into viewer research on a big scale. Readers are being invited to fill up a questionnaire on their likes and dislikes. This lines up with the traditional policy of this paper, which gave powerful help to motoring and aviation in their early days, and more recently to British Films. The *Daily Express*, just past its 50th birthday and lively as ever, seems unable to co-ordinate television with its forceful policy of Empire Free Trade. The *Evening Standard*, its close relation, is, however, a little more advanced.

LIME GROVE

THERE was no flourish of trumpets to herald the entry of Lime Grove Studios into the television field. Quietly and unostentatiously, it was brought into use as a television studio on a Sunday in May, when the first special TV Children's Hour was transmitted. This was, in fact, made into quite an "occasion" in its own right, with a pleasantly-performed opening speech by Mrs. Atlee, and with Wilfred Pickles and Jimmie Hanley as principal guests. There were no grandiose settings or elaborate showpieces: just a simple little drawing-room set with a grand

piano for Muffin the Mule to dance on! The fact that a momentous milestone had been reached, and that the B.B.C. were inaugurating the largest studio building in the world exclusively devoted to television, seemed to be unduly played down. Still, perhaps this event will be suitably marked when the Lime Grove Studios launch out on plays, variety and general television entertainment.

STUDIO ACOUSTICS

THE TV sound quality is recognised as being first-class. Our ears have become accustomed to the acoustic effect of the two small studios at the Alexandra Palace and have made allowances for the varying sound conditions of other transmissions, relayed from outside. Theatre conditions have not provided very good results, possibly due to microphones being located in the footlights, and other outside relays have invariably been dominated by a commentator. The true test will come shortly—maybe before these notes are printed—when the Lime Grove Studios at Shepherd's Bush go into action. With walls covered with blocks of slag wool up to 4in. thick, their reverberation time is extremely small, especially at low frequencies. I believe it is of the order of a third of a second compared with the 1.25 to 2 seconds reverberation time preferred by the B.B.C. for orchestras of 50 or more musicians. High reverberation times are unsuitable for dialogue, especially when the speakers have to be some distance away from the microphone.

U.S. TELEVISION CUTTING TECHNIQUES

THE latest news I have received from America indicates that the stimulant of competition between the rival television networks has led to the development of a very slick editing technique, including a few surprising tricks not yet seen on British television. There is a popular weekly series known as "Garroway at Large," which always has a surprise ending. At the end of a recent programme, the casual Garroway picked up a camera cable that was lying on the studio floor and explained to the audience that it was the co-axial cable taking the trans-

mission across the country. "It's about time to end the programme now," he said, looking at his watch and picking up a small shiny hatchet. "Now this might hurt a little," he added. He brought the hatchet down and the picture went black. In a few seconds, however, Garroway was back with his closing gag, holding up the cable with a big bandage around it, as he introduced the next programme. "This next show comes to you from Chicago, where we have very good connections!" he said, as the picture dissolved over to the Chicago Studio. But this is just an amusing little stunt, one of many. The Americans have studied white fade-ins or fade-outs as an occasional alternative to the more usual black fades; the use of defocus for indicating transition of time, the "wipe" in which one picture gradually slides across and wipes out the first one, and the split screen, in which two persons in different studios are seen in the same frame of picture. For instance, an interviewer in New York was shown on the same screen as the interviewee in Washington, the two being seen side by side, carrying on a telephone conversation. Turning to plays and musical shows, the cutting from camera to camera has been very intelligently studied with a view to slickness of continuity, and has borne in mind the particular part of the screen upon which the viewer's eye is riveted, or any matching movement that may take place in the action of the adjacent cuts.

They have also found from experience certain editing pitfalls which must be avoided:

- (a) Don't cut too much. Jumping from shot to shot irritates viewers. Cuts should be used for dramatic punctuation, not just for the sake of cutting.
- (b) Don't cut blindly, otherwise you may switch over to a TV camera that is not ready, out of focus, or centred on the wrong character.
- (c) Don't cut from one shot to another one of similar type, even if it shows a different angle. A cut from a shot of two characters to another angle of the same two characters doesn't mean anything.
- (d) Don't cut to an extremely different angle. The difference may be so great as to make the location of the second shot unrecognisable. This sometimes makes the viewer perform mental acrobatics to remember the geography of the scene. Reverse angles

across the shoulders of each of two artistes holding a conversation are, however, permissible.

- (e) Don't cut from shot to shot haphazardly in musical sequences. Accuracy of cutting is especially necessary for musical numbers. The cut should be dead on the beat, at two bar, four bar or eight bar points.

The next time you watch a television play, you'll recognise these faults. The best of the B.B.C. producers don't make 'em, but some do.

CHILDREN'S NEWSREEL

THE first number of the Children's Television Newsreel followed to a great extent the style and content of the late Arthur Mee's classic publication, *The Children's Newspaper*. That is to say, the make-up had the characteristics and subject matter of non-fictional magazine presented in the journalistic form of a newsreel. It was evident that great care had been taken in the selection of film material from many sources, and that these varied items were skilfully cut and edited, commented and set to music. The result was a smooth and entertaining film feature in which education was painlessly administered to attentive children—and also to their spell-bound parents. I am not at all averse to a fairly large proportion of "magazine" items in a newsreel. Usually, being undated, they can be much more carefully prepared than pure "news stories." The grown-ups' Television Newsreel has a rather lower proportion of such magazine items, but even this carries a much greater amount of magazine sequences than the cinema newsreels. *Movietone*, G.B. and other newsreels always have a few non-dated "stories" in their vaults, ready for bringing out when real news items are in short supply or foggy weather has prevented their cameraman from obtaining the bi-weekly quota of news. But the cinema-going public, having paid their money for news on film, do not take too kindly to large doses of undated magazine "news." — Every scientific invention seems to offer the prospect of breaking down insularity of the public mind, reducing local prejudices to a common denominator of mutual understanding. Broadcasting has done more than anything to eliminate differences in the mental attitudes of different sections of the public and in their manner of actual speaking.

What will television do? But, conversely, the aims and ideals of governments differ, and radio and television offer the propaganda media par excellence for an ethical clash between democracy and totalitarianism.

In countries where the herd instinct is developed to a high degree and individualism is discouraged, propaganda is the normal method of formulating public opinion. On the other hand, countries where individualism and enterprise are preserved recognise propaganda as a "necessary evil," and impartiality is looked upon as a treasured virtue. In other words, the Englishman and the American both instinctively dislike being consciously "told" or instructed, but they are open to coaxing or persuasion. Here lies one of the pitfalls of both television and sound radio; they are natural platforms for the Public Relations Officer.

INDIVIDUALISM AND AERIALS

THE individualism of British television viewers is exposed to the heavens in the varying types of aerials they erect above their homes. Even the orientation of directional aerials seems to vary from house to house in certain districts. I noticed in the Twickenham area a number of TV aerials, all of the "H" type, facing in widely-differing directions.

I have lately become acutely conscious through personal experience of the importance of twisting the dipole so that it faces *exactly* the right point of the compass. The reason for this is my removal from a suburb of London to a point which is reputed to be on the fringe of good reception in the London TV area. Shortly after arrival at my new house I erected a temporary "H" aerial on a short mast, only 16ft. above the ground, with the dipole and reflector roughly disposed for A.P. reception. The image was harsh, with double edges to any contrasty vertical lines which might be in the picture. Slowly, the pole was rotated until it was completely extinguished, at which point the reflector was pointing towards the Alexandra Palace. Then the pole was again rotated until the dipole took up the exact position formerly occupied by the reflector. The resultant picture was bright and clean, free from reflection shadows and—as luck would have it—with a very considerably increased signal strength. The moral is: Don't always trust your reading of compass bearings!

TRADE TOPICS

Bel Sound Products

THE illustration below shows the P.M. focusing unit produced by Bel Sound Products which has some unique features. Available in two models, one for triodes and one for tetrodes, these units require no supporting fixtures. A loose inset of springy material has turned-down fingers at each end, and this is slipped

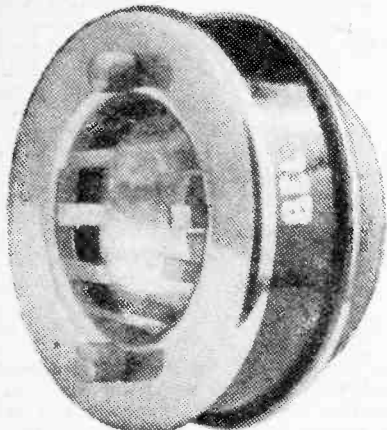

Bel Sound Products P.M. focusing unit.

over the tube neck after which the unit is pushed on. The spring fingers are thereby compressed and the magnet is held firmly in any desired position, but perfectly concentric round the tube neck. As it is usually found that this type of magnet is not evenly magnetised and the picture is sometimes put off centre, the front plate of this particular make of unit is held on by two knurled bolts, and by loosening these and sliding the plate as required the picture may be perfectly centred, and the entire magnet may then be rotated without any movement of the picture. Focusing is carried out by rotating a knurled ring at the rear which carries out the usual adjustment of the gap. This has a very fine thread and provides almost a micrometer adjustment. The price is 25s. for the triode model and 22s. 6d. for the tetrode model.

Coils for the P.W. T.R.F. and superhet. television receivers are also available from this firm, and samples which we have tested were found to be wound exactly to specification, each clearly marked and the coils are "doped," ensuring that the turns will not move even when the ends are scraped for subsequent connection. The set of eight coils and V.F. choke for the T.R.F. model cost 16s. 6d. for London, and 18s. 6d. for the Midland frequency. The superhet. coils cost 35s.

Bel Sound Products Co.,
Marlborough Yard,
London, N.19.

Interference from Television Time-based Circuits

TELEVISION time-base power supply circuits pulsed by the fly-back potential or other means, may cause interference with other electronic equipment over a considerable area.

One satisfactory method of overcoming this is to screen the cabinet. A special dispersion of "dag" colloidal graphite has been developed by Acheson Colloids, Ltd., which can be applied by brush or spray, to the inside of the cabinet, thereby providing an effective screen and attenuating interference.

The treatment can be carried out rapidly and is extremely simple, and manufacturers who are interested in the use of "dag" colloidal graphite should write for details.

Acheson Colloids, Limited,
18-19, Pall Mall,
London, S.W.1.

Taylor Instruments

THE present heavy demand for an open-scale instrument of a modern design has led Taylor Electrical Instruments, Ltd., to introduce a new model to their extensive range of panel mounting meters.

This latest introduction is known as Model 370 and is available in moving coil, rectifier and thermo-couple types.

Introduced for the first time at the British Industries Fair was the "Montrose" multimeter, an inexpensive pocket (moving-iron) instrument for giving the following ranges.

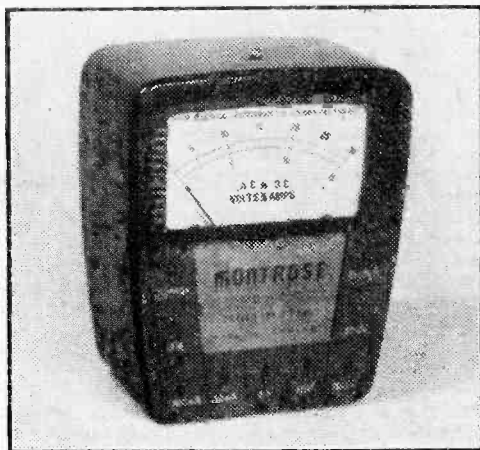

A new Taylor instrument.

Ranges.—Volts: 0—5—30—150—300; Current: 0—30 mA.—300 mA.—3 Amperes (A.C. and D.C.).

A 1.5 v. battery is fitted internally for circuit tests.

Finish.—Moulded case, affording easy access to battery.

Dimensions.— $3\frac{3}{8}$ ins. \times $3\frac{1}{12}$ ins. \times $1\frac{7}{10}$ ins. (9.3 \times 9.2 \times 4.3 cms.).

Weight.—7 ozs. (0.4 Kgm.).

Taylor Electrical Instruments, Ltd.,
Montrose Avenue, Slough, Bucks.

A New "Melody Maker"

LAST year's Radiolympia revival of the Cossor "Melody Maker" has proved immensely popular with both trade and public, but there are many who have asked for a wood cabinet version.

This has now made its appearance as Model 500 at 17½ gns., tax paid. While following the general specification of the current set, the opportunity has been taken to introduce one or two circuit modifications which result

in improved signal-to-noise ratio and more efficient tone control.

The appearance is very nice, with polished walnut cabinet, larger dial with three-colour calibrations, and "gold" metal grille.

A. C. Cossor, Ltd.,
Cossor House, Highbury Grove, N.5.

Trimming Kit

A NEW trimming kit has been produced for the serviceman and experimenter, and is designed for use on both radio and television equipment. Known as the Newman Master Set Trimmer Kit, it contains in a pocket-size metal container, measuring 4in. x 4in. x 1in. deep:

- 1 end trimmer
- 1 side trimmer.
- 1 Yaxley switch contact adjuster.
- 1 low capacity trimmer
- 1 screwdriver.
- 1 set of feeler gauges.
- 1 set of six box spanners from 1 to 8 B.A.
- 1 set of four spanners from 0 to 8 B.A.



The Newman trimming kit.

The case has a durable black crackle finish, and the price is 25s. 6d. post free.

J. & S. Newman, Ltd.,
100, Hampstead Road, N.W.1.

New Osram Miniature Valves

THE General Electric Co., Ltd., announces two additions to the range of Osram miniature valves.

Type X109

This is a high efficiency triode-hexode frequency changer on a miniature B9A (noval) base and completes the range of Osram D.C./A.C. miniature valves designed for series heater operation with a current of 100 mA.

The complete range is as follows:

- X109 triode-hexode frequency changer.
- W107 variable- μ H.F. pentode.
- DH107 double-diode-triode.
- N108 high slope output pentode.
- U107 half wave rectifier.

All valves in this series have B7G bases, with the exception of the new introduction (X109) which has been mounted on a B9A base so that heater and cathode connections can be separate. This permits the frequency changer to be "one up" in the series heater chain, and the double-diode-triode to be wired at the "earthy" end of the chain to minimise hum.

Type N19

This is a 1.4 volt battery output pentode on a B7G base. The filament is centre-tapped to enable the dual rating of 2.8 volts, 0.05 amp; or 1.4 volt, 0.1 amp to be obtained when the valve is used in battery/mains receivers. It is equivalent to the American type 3V4 and completes the range of Osram battery miniature valves, which comprises:

- X17 (=American 1R5) frequency changer.
 - W17 (=American 1T4) H.F. pentode.
 - ZD17 (=American 1S5) single diode pentode.
 - N17 (=American 3S4)
 - N18 (=American 3Q4)
 - N19 (=American 3V4)
- } Alternative output pentodes.

General Electric Co., Ltd.,
Magnet House, W.C.2.

Somerford Transformers

MESSRS. GARDNERS RADIO, makers of the well-known Somerford chokes and transformers, have now produced a new brochure illustrating their standard range of equipment. This is a 27-page production giving, besides technical data, drawing and chassis cutting information.

Gardners Radio, Ltd.,
Somerford, Christchurch,
Hants.

Co-axial Attenuator

A NEW co-axial link has been produced by Messrs. Belling & Lee, well known as makers of plugs, sockets, etc. This link has the appearance of a normal co-axial plug and socket, but is intended to be used with the type L600 co-axial feeder, and is available with insertion losses of 6, 12, 18, 24 and 36 db. Where the normal unscreened balanced feeder is in use it is possible to utilise this component with little modification, and the same attenuation may be obtained.

Belling & Lee,
Cambridge Arterial Road,
Enfield, Middlesex.

E. H. T. Components

THE Hazlehurst E. H. T. unit, which is used in the P.W. Television Receiver, utilises a standard oscillator coil unit which is available separately in various ratings for those who wish to build up their own E. H. T. unit of the R.F. type. The coils are well made on special formers, and great care has been taken in the insulation to prevent flash-over on the coil itself. Full instructions for building the units are supplied and the coils are obtainable for a 5.5 kV unit at 22s. 6d., or for 8 kV at 30s. If it is required to obtain a greater output, say up to 12 kV for an aluminised tube, for instance, the 8 kV coil may be used in a voltage-doubling circuit.

Hazlehurst Designs, Ltd.,
34a, Pottery Lane, W.11.

REFRESHER COURSE IN MATHEMATICS

8/6, by post 9/-

by F. J. CAMM

GEORGE NEWNES, LTD.

Tower House, Southampton Street, London, W.C.2

"VIEWMASTER" TELEVISOR

The complete range of all specified Components and Valves are in stock for either London or Midland Receivers. Full Wiring and Instruction detail with practical Component Layout available for 5/- (plus 3d. post).
Complete T.C.C. CONDENSER KIT. £6 15s.
 Individual Components can be supplied separately.
Complete MORGAN RESISTOR KIT. £1 6s. 9d.
 Individual Components can be supplied separately.
Complete W.L. CHASSIS OUTFIT, including Transformer, Choke, Speaker, etc. £6 5s.
 Individual Components can be supplied separately.
Complete PLESSEY TRANSF. OUTFIT. £5 12s. 6d.
 Individual components can be supplied separately.
Complete COLVERN VARIABLE RESISTOR OUTFIT. 19s. 3d.
Complete BELLING LEE ACCESSORIES OUTFIT. 7s. 6d.
Complete WESTINGHOUSE RECTIFIER OUTFIT. £3 2s. 6d.
Complete WEARTE COIL & CHOKE OUTFIT. £1 2s. Midland, £1 10s.

We will supply this TV Receiver by the separate specified Stages (send 3d. stamp for details).
THE "ELECTRONIC TELEVISOR"—Full Wiring and Instruction Detail available for London 2/6, Midland 4/6 (plus 3d. post).

The Complete range of COMPONENTS and VALVES can be supplied from stock for the VIEWMASTER and ELECTRONIC.

A MIDGET T.R.F. BATTERY PORTABLE "PERSONAL" KIT. A complete Kit of Parts to build a Midget 4-valve All-dry Battery Personal Set. Consists of Regenerative T.R.F. Circuit employing Flat Tuned Frame Aerial, with Denco Iron Dust Cored Coil, thereby ensuring maximum gain for Single-Tuned Stage covering medium Waveband.

Valve Line-up: IT4 (R.F. Amp.), IT4 (Detector), 1S5 (1st A.F.), and 3S4 (output). Includes latest Rola 3in. Moving Coil Speaker, and a Chassis already drilled and shaped. A Consumption of only 7 mA. ensures long battery life. The Kit is designed for a cabinet, minimum size 6 1/2in. by 4 1/2in. by 3in. Detailed Building Instructions with Practical Layout and Circuit included with Kit make assembly easy.
Price for complete Kit £3 18s. 9d. (plus 16/7 P.T.). Suitable unpainted Cabinet 6 1/2 by 4 1/2 by 3in. 12/9. Ever ready B114 Battery. 9/7. Building Instructions, Circuit, etc., supplied separately. 1/-.

Send a 3d. stamp for our COMPREHENSIVE STOCK LIST of Wireless Components and Accessories. Please cover cost of post when ordering.

STERN RADIO LTD.
 109 & 115, FLEET STREET, E.C.4.
 Tel: CENTRAL 5814 and 2280.

T.V. in the FRINGE AREAS

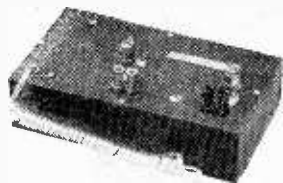

★ **A Superior PRE-AMPLIFIER**

By "RAINBOW"

For use with: CO-AX or BALANCED FEEDER

Built in Power Pack, with metal Rectifier, E.F.91 valve, exclusive Rainbow Coils, complete with all Plugs. Crackle Finish, Steel Case, 8 1/2in. x 4 1/2in. x 2 1/2in.

PRICE £5 · 17 · 6

Alexandra Palace or Sutton Coldfield Model. 's giving excellent results with Receivers by Bush, Pye, H.M.V., Marconi, Philips, etc. It's to your advantage to write for fuller details

RAINBOW RADIO
 MANUFACTURING COMPANY LIMITED
 MINCING LANE, BLACKBURN, LANCs, ENGLAND

Essentials for the TV CONSTRUCTOR

Rectifier Valves.—5U4, 616; 5Z4, 616; 5T4, 816; 5Y3, 616; VU120, 316; VU133, 51; VU111, 316; 2X2, 716.
H.F. Pentodes.—EF50 new and boxed, 716; used but tested, 51; EF54, 616; EF55, 816; 6SG7, 616; 6SK7, 616; 6SJ7, 616; 617, 616; 6K7, 616; EF36, 61; EF39, 61; SP41, 31; SP61, 31.
Output Valves.—6V6, 616; 6F6, 616; 2A3, 316; EL32, 616; Pen 46, 51.
Diodes.—VR92, 216; VR78, 216; EB34, 119; EBC33, 616. 6H 70 mA CHOKE, ADMIRALTY RATING, 219.
High voltage condensers.—1 3 kV Block or Mansbridge, 216; 1, 2.5 kV Can, 216; 1 mfd 3 kV Test, 31; .25 mfd 1,500 v. wkg., 9d.
Smoothing Condensers.—8 x 16 450 v. BEC Small Can, 313; 8 mfd 450 v. BEC Small Can, 213; 25 mfd 25 v., 11; 50 mfd 12 v., 11.
ORDERS OVER £1 POST FREE.

Miscellaneous.—6in. CRT Enlargers. Increases picture size to approx. 9in. Plastic oil-filled type of superior quality. Heightens picture definition—a necessary addition for pleasurable viewing. 25/-, plus 1/6 post and packing.

VCR 97, CRT mu-metal screens, 416 per pair. White mask for VCR 97, 716. Imparts a professional touch to the finished television.
Aerials.—A very comprehensive range available from stock for either London or Midland Transmitters. Prices from 21/-. Let us quote you for the aerial necessary in your district. Special arrays at moderate prices. ALL AERIALS SPECIALLY WEATHER-PROOFED AND VERY HIGH EFFICIENCY IS ASSURED THROUGHOUT.

THE "VIEWMASTER"

Every Part and Specified Kit of Components for London or Midland Transmitter can be supplied promptly from stock. Practical guidance and advice given to all constructors purchasing kits from us. In the first instance send for the 5s. Constructional Envelope.

We can supply most of your TV requirements. Why not visit us at our easily accessible London premises? A competent technical staff always in attendance and at your service.

Best Buy at Britain's

CHARLES BRITAIN (RADIO) LTD.
 11, Upper Saint Martin's Lane, London, W.C.2
 OPEN ALL DAY SATURDAY

Shop Hours: 9-6 p.m. (9-1 p.m. Thursday). TEM. 0545.



THE NEW B.P.L. SUPER RANGER

20,000 OHMS PER VOLT.

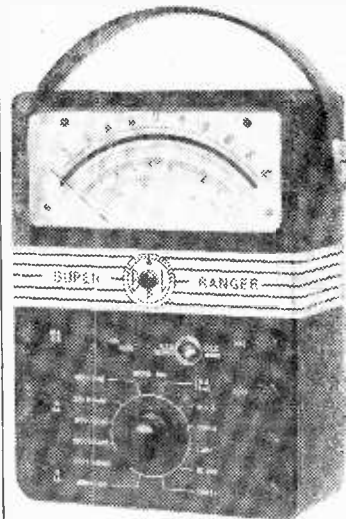

D.C. VOLTS: 100mV to 5kV
D.C. CURRENT: 1 μA to 1 Amp.
A.C. VOLTS: 0.5 V to 5kV.

A.C. CURRENT: 10 mA to 10 Amps.

RESISTANCE: 1 ohm to 2 megohms.

OUTPUT: 0 to 62 db.

METER: 5-inch Long arc, fitted with knife - edge pointer and mirror scale.

NET PRICE: £14 - 10 - 0

BRITISH PHYSICAL LABORATORIES
 HOUSEBOAT WORKS, RADLETT, HERTS.

Tel.: Radlett 5674-5-6

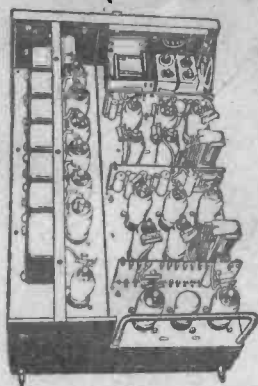

RECEIVER R3515

This 21-valve Radar receiver is ideally suited to the construction of an inexpensive television receiver. The six-stage IF amplifier is on a frequency of 14 m/c, and has sufficient bandwidth to produce an excellent definition picture. The space on the chassis is such that the complete receiver can be constructed as one unit (excluding power supplies) and it makes a compact arrangement.

(See article in "Short Wave Listener," May)

BRAND NEW £3 10s. CARRIAGE PAID
(in crates)

RECEIVER R1355

10-valve receiver for use with the RF 26 unit for television. Highly sensitive 7 m/c IF strip. Makes a first-class receiver.

BRAND NEW £3 10s. Carriage Paid

R1355 I.F. TRANSFORMERS

Replacement 7 m/c IF Transformers for the R1355 Receiver.

4 for 5/- Carriage Paid

VCR 97 EHT TRANSFORMER

Vacuum impregnated and wax sealed. Fully interleaved. 2.5 kv at 4MA 4v. CT and 4v.

BRAND NEW 32/6 plus 1/6 postage

ELLISON R1355 TRANSFORMER

Transformer specially designed for use with the R1355 receiver. Recommended by "INEXPENSIVE TELEVISION." Ratings 350-0-350v. 120MA. 6v. and 5v.

BRAND NEW 27/3 plus 1/6 postage

VCR 97 TUBES

BRAND NEW, boxed in sprung crates, and fully guaranteed.

30/- plus 3/6 carriage

VCR 97 MAGNIFIER

First-class magnifier with minimum optical and colour distortion, specially designed for use with the VCR 97.

BRAND NEW 25/- plus 1/6 postage

VCR 97 MASK

Cream rubber mask for use with the VCR 97 when used as a television tube.

BRAND NEW 7/6 plus 9d. postage

100 WATT AUTO TRANSFORMERS

Small, sturdy and reliable auto transformer, for using 110 volt equipment on 200-230v. A.C. mains or vice versa.

BRAND NEW 15/9 plus 9d. postage

UNIVERSAL OUTPUT TRANSFORMER

Designed for single end or push-pull output stages. Will match any output valve.

BRAND NEW 4/11 plus 6d. postage

CONDENSERS

.1 μF 5,000v. wkg. The ideal EHT smoother. 4/11. post paid. .1 μF 1,500v. wkg., for lower EHT lines supplies. 1/9 plus 3d. postage.

WE STOCK A FULL RANGE OF VIEWMASTER COMPONENTS which are available on cash or HIRE PURCHASE TERMS. Your enquiries will be welcomed.

M.O.S. MAIL ORDER SUPPLY CO.

The Radio Centre, 33 Tottenham Court Rd., London, W.1.
Telephone: MUSEum 6667-8-9.



"A worth while addition to any television receiver."
"PRACTICAL WIRELESS & PRACTICAL TELEVISION" Magazine.

CUT THIS HANDY COUPON NOW
OUT

To: NEW LOOK PRODUCTS (ENGRS.)
CRANLEIGH, SURREY

Please send me, without obligation, illustrated details of the New Look
Teleset-Filter, and of your Free 7 Days' Trial. My set is a.....
Stamp enclosed

Name

Please Print.

Address

CONVERT

YOUR set to produce pictures like those from the latest models with 'Built In' Filters by attaching a TELUMINISED NEW LOOK FILTER

T.M. Guaranteeing . . .

- ☆ Freedom from Eye-strain.
- ★ 80% Clearer Pictures.
(Even in Full Room Light)

- ☆ No Distortion.

PRICES FROM ONLY

15/-

- ★ No Screws or Straps.

- ☆ Ideal for 'VCR 97,' 'View-master' and all other TV sets regardless of size.

- ★ Easily attached without harm to cabinet or tube.

- ☆ FREE SEVEN DAYS' TRIAL

← Send coupon for details.