

Making a "Cannonette" Table

NEWNES



PRACTICAL MECHANICS

EDITOR - F. J. CANNON
NOVEMBER 1953

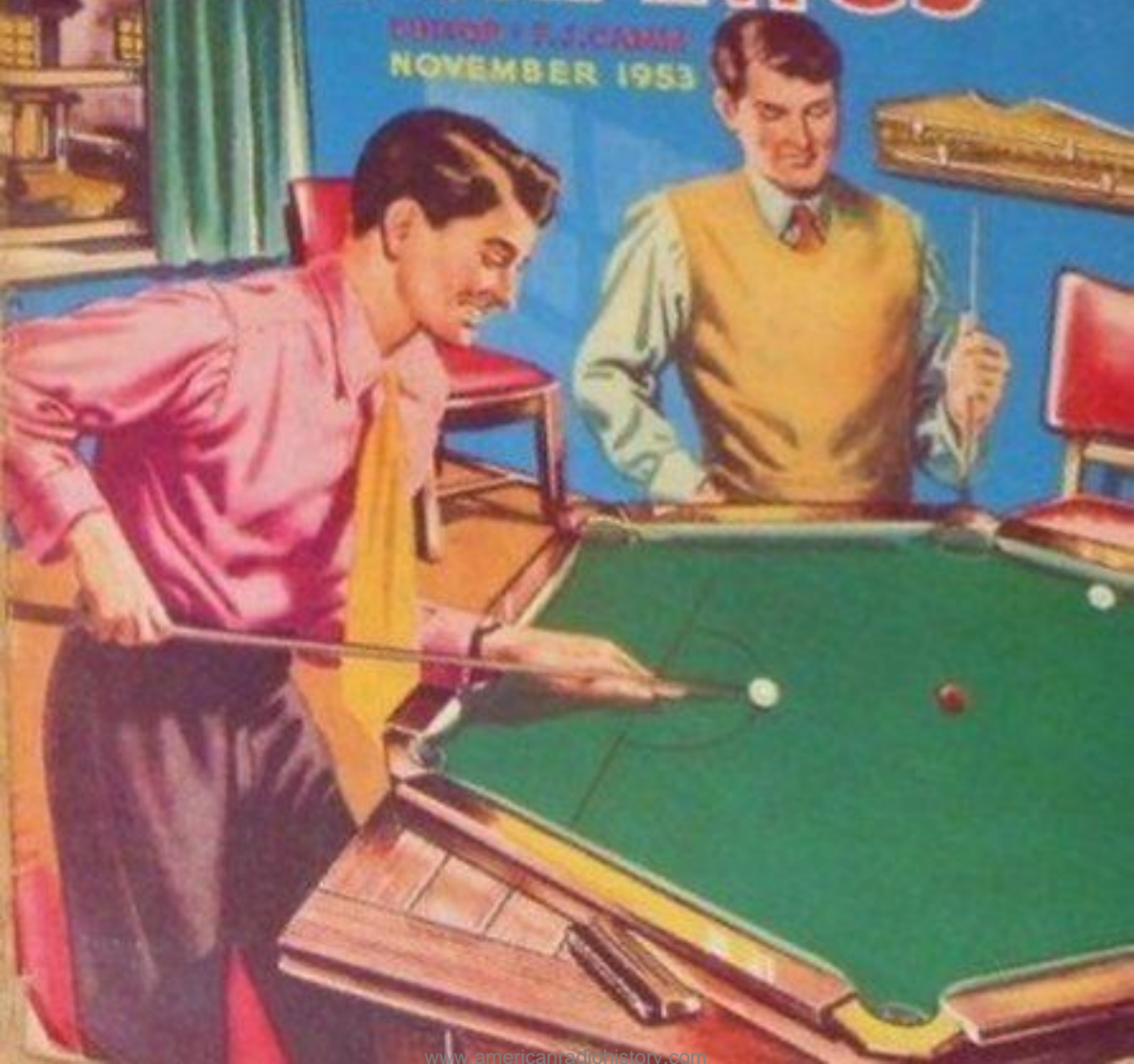

NOVEMBER,
1953
VOL. XXI
No. 239

PRACTICAL MECHANICS

EDITOR
F. J. CAMM

The "Cyclist," "Practical Motorist," and "Home Movies" are temporarily incorporated.

FAIR COMMENT

By The Editor

Flying Saucers From Venus?

IT is somewhat surprising that although hundreds of people in different parts of the world have seen objects flying in the sky resembling flying saucers, no accurate information which places their existence beyond all doubt has yet come to hand. The stories first started in America and, with their usual predilection for "hotting up" the news, most of the early reports were accepted with a pinch of salt. Some imaginative people claim to have looked inside one which had landed and saw miniature men inside. Others were far more descriptive and responsible members of the American Air Force supported the stories that such aircraft were in existence. It was noised abroad that they were secret weapons undergoing tests, but the American Government promptly denied it. Others thought that they were radiosondes.

All has been conjecture and all open to doubt. A book recently published entitled "Flying Saucers Have Landed" adds further doubt and gives rise to further speculation. The two authors claim that they have seen and photographed one of the flying saucers, and one of the authors claims to have spoken to the pilot who, by gestures and some system of telepathy, explained that he had come from Venus! This latter author lives in California, he is a café assistant and general handyman, and in his spare time lectures on philosophical subjects. He is also a keen telescopicist. We are told that he has given a great amount of attention to the history of flying saucers, and claims to have photographed distant specimens. He claims that on November 20th, 1952, he was out with six friends, who are named, when suddenly they saw flying soundlessly over a mountain ridge a gigantic cigar-shaped silvery ship without wings or appendages of any kind. It was obviously a spaceship, they thought. Bearing in mind their interest, it is somewhat surprising that they did not immediately photograph it. One of the authors felt that his dream of conversing with the pilot of a spaceship would come true, and he therefore asked his companions to drive him along the road. Soon they saw the same aircraft apparently following them, and they turned off

the road where a telescope and camera were set up. We are told that when the car stopped the ship stopped also. *At this point the author asked his companions to leave him alone, and the reader might well ask, why?* However, his attention was attracted by a flash in the sky and "almost instantly a beautiful small craft appeared to be drifting through a saddle between two of the mountain peaks and settling silently into one of the coves about half a mile away." He took some snapshots of it, but it suddenly disappeared. But a little later he saw "a man standing at the entrance of a ravine between two low hills about a quarter of a mile away. He was motioning me to come to him." This stranger had long hair and was wearing ski trousers. The author immediately concluded that this was a human being from another world. A long "conversation" followed, and from it the author learned that the visitor came from Venus, the inhabitants of which had been anxiously observing the course of atomic explosions on Earth and that some Venusians were living on earth in disguise. Throughout "he felt himself to be in the presence of a superior being far advanced in knowledge and wisdom."

One wonders how the Venusian knew that we had named his planet "Venus", and how they knew about our atomic experiments. It is also a matter for wonder why events which took place in 1952 have only just been revealed in this book. As far as I am aware they have not been disclosed before.

Eventually, he walked back with the Venusian to the small space craft which was hovering about a foot from the ground. He gathered that it had come

from the large mother ship which had been seen earlier. As the two walked, the visitor pointed to the curious markings which his shoe soles had impressed in the desert surface. He later took plaster casts of them. The space craft is described in some detail. He says that upon approaching it he received a shock which jerked up his right arm and left a bruised numbness which lasted for three months. He was, however, refused a trip. Finally, the visitor climbed in and the craft glided silently away.

The visitor asked the author for some camera films in holders, promising to return them. We are informed that on December 13th, 1952, at nine o'clock in the morning, the space craft glided down to within one hundred feet of where the author was standing near his home, a hand emerged from a porthole, and the film holders were dropped out. When the film was developed it was found to be covered with hieroglyphics which nobody has yet deciphered.

The intelligent reader may wonder why the Venusian had not developed the film himself. However, it was on this occasion that the photographs of the space craft reproduced in the book were taken. His friends have sworn affidavits saying that they had witnessed his meeting with the man from the space craft and there is a pencil sketch of the man. One wonders: why not a photograph.

One can consider this book in the light of three possibilities: that it is true; that it is a piece of fiction or intended as a hoax perpetrated on the author; or that it is a piece of hallucination.

No one will deny the possibility that there is life on other planets, but from our present knowledge of science it does not seem possible that they could sustain life here. As the book is advanced as a statement of fact it is hardly likely that the six friends who have signed affidavits would expose themselves to actions for fraud.

The whole of the book savours of science fiction, although it is presented as fact. In reading it through I must say that I remain unconvinced without in any way casting aspersions on the integrity of the author or publishers.

—F. J. C.

SUBSCRIPTION RATES

including postage for one year

Inland - - - - 14s. per annum.
Abroad - - - - 14s. per annum.

Editorial and Advertisement Office: "Practical Mechanics," George Newnes, Ltd., Tower House, Southampton Street, Strand, W.C.2

Phone: Temple Bar 4363

Telegrams: Newnes, Rand, London.

Copyright in all drawings, photographs and articles published in "Practical Mechanics" is specially reserved throughout the countries signatory to the Berne Convention and the U.S.A. Reproductions or imitations of any of these are therefore expressly forbidden.

Making a "Cannonette" Table



The finished table ready for use.

A "Cannonette" Table is an Ideal Substitute for an Actual Billiard Table. Below We Give Full Constructional Details and Method of Playing This Fascinating Game

THE "Cannonette" table provides a good substitute for the actual billiard table, and the following article gives full particulars for its construction. The "Cannonette" tables can be made in three sizes, 2ft. 6in., 3ft. 6in., and 4ft. 6in. across the flats. For the purpose of this article, the middle size has been chosen. The bed of the table itself should be cut from a sheet of plywood, if possible $\frac{3}{4}$ in. thick, but a $\frac{1}{2}$ in. ply will do if you take care to keep it flat when fixing it to the battens. The hexagon shape should be traced upon the ply in the following manner: Obtain a piece of spare wood about 24in. long, and at one end drill a hole large enough to allow a pencil to be tightly pressed into it. Measure from the point $22\frac{1}{2}$ in. and tap in a panel pin as shown in Fig. 1. You can now scribe a circle upon the board 45in. in diameter, which, when divided into six, will give you the centre for each of the six sides. Having cut the table top to shape, you can now turn your attention to the cardboard template that it is advisable to make for the pocket gaps at each corner. Fig. 3 gives details for marking this out upon a piece of thick card, which is cut to shape, with the edges bent down to form a stop when it is placed upon the corner of the hexagon. After marking each corner carefully from the template, saw neatly round with the aid of a keyhole saw or a coarse fretsaw blade. Partly to increase the strength of the ply, but mainly to support the side panels, there are screwed upon the underneath of each edge, pieces of deal $\frac{3}{4}$ in. by 1 $\frac{1}{2}$ in. by 22in. long. These are shown in the general plan of the table, Fig. 2.

Fixing the Battens

The next step is to fix the battens across the width of the table, these also being cut from the same material. Oak can be used for these if extra strength is required, although it will increase the weight of the set when finished. Having pencilled out the positions of these battens upon the ply, Fig. 2, place the battens upon them and mark off for

length, two of them having square cut ends and two with ends cut at an angle. Fig. 4 shows the battens as they appear before locking together. The screws for fixing the top to the battens should have countersunk heads

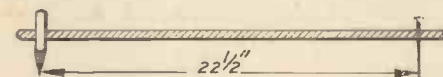

Fig. 1.—Improvised trammel for drawing a circle.

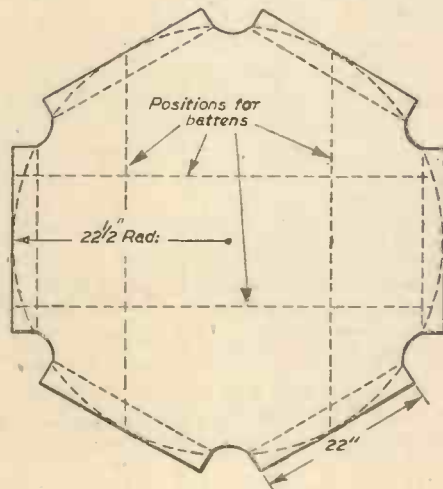

Fig. 2.—Showing the position of the table supports.

and be about No. 6 in size. Drill the clearance holes along the lines, six for each batten, and slightly countersink them and lay the top in position upon the battens ready for fixing. Drive the screws well home, and before filling with plastic wood, it will be as well to test the top with a straight edge.

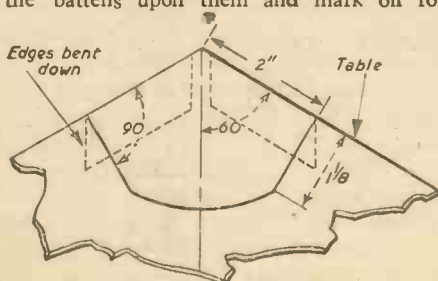

Fig. 3.—How to mark out the pocket gaps.

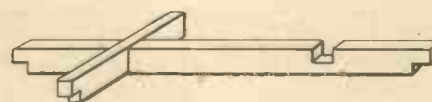

Fig. 4.—How the battens are interlocked.

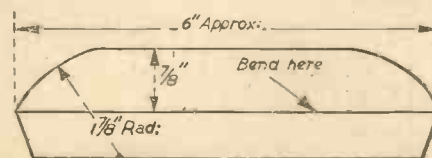

Fig. 5.—Details of the cushion slips.

If the top is quite flat upon the battens, fill over the screw tops and set aside whilst you continue with the rails and cushions. These will not prove very difficult if you proceed with care. In the first place cut the six rails from oak, $\frac{3}{4}$ in. by 1 $\frac{1}{2}$ in. by 22in. long; these are finished sizes, and can be obtained from any cabinet-maker's shop, thus saving yourself a heap of shavings and extra work. Smooth each of them well with sandpaper, and give a coat of spirit stain, fairly dark.

The Cushion Slips

These slips are cut to length $\frac{1}{4}$ in. less than the rails, which should make them 21 $\frac{1}{4}$ in. long. Once again, to save time and ensure that all curves are the same, a template should be cut as in Fig. 5, from which each slip can be marked and cut. Those readers who are not well equipped with tools should saw straight across the corner upon the outside of the line, holding it afterwards in the vice and shaping it up with the aid of a coarse file, until it conforms with the curve of the template. Before polishing the rails it is probably best to screw the slips into position, that is temporarily, in order that they may be readily fixed when covered. The cushion is made from 3/16in. square section rubber, obtainable from most model aeroplane stores. Each slip will require 18in. of rubber, so 9ft. will be needed for all six slips. Taking one 18in. length of rubber and a slip, attach the rubber at one end by means of a panel pin, taking care not to split the wood and also not to flatten out the end of the rubber. Along the top edge of the slip spread a thin coating of liquid glue over which the rubber is stretched, and finally pinned at the opposite end of the slip. Press the rubber cushion firmly all along its length, keeping it quite flat with the top of the slip. The slips should now appear as shown in Fig. 6. The oak rails having dried from their staining, can now be polished.

The Baize Covering

At this stage, the table can be covered with the baize, having sand-papered the top perfectly smooth. It is advisable now to

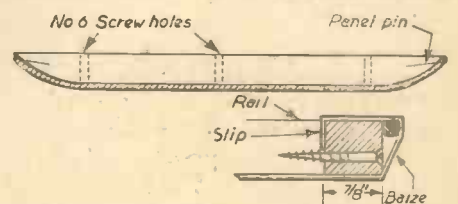

Fig. 6.—Plan and section of a completed cushion slip.

obtain the assistance of a friend, as the material has to be stretched very tightly and evenly over the entire surface. If you have obtained the baize in what is known as "double width," you will find that it is wide enough to stretch across the flats of your table, allowing enough to be cut off for use upon the cushion slips. Tack the edges of the baize with drawing-pins as you stretch it over. Having pulled it as tight as possible, run over the entire surface with a fairly hot iron, keeping it moving in one direction only, taking up the extra stretch of the material as you do so. By making two or three snips at the pocket gaps, it will be quite easy to draw the baize down and round the curve. When the rubber cushions have set firmly upon the slips, you can commence covering them with baize, which should be cut into strips long enough to allow the ends to be turned and tucked in between the rail and the slip. To commence the covering it is first necessary to place the slips against the rail and insert the three screws, leaving them slack to enable the baize to be inserted. Place the edge of the baize between the rail and the slip and then drive the centre screw home, after which the baize is drawn across, down, and under the slip, where it is tacked. Turning the corner may prove a little difficult at first, but you

can. Sand-paper the sides, stain and polish as you did with the rails. The four feet are made adjustable for leveling purposes.

The Four Feet

Ordinary drawer knobs can be fitted, provided that they possess a dowel pin upon which they can be turned. This type of foot is shown in Fig. 7, whilst B illustrates another method, giving them a much better appearance, by taking four 7/16in. hexagon headed screws and drilling the head out to 3/4in. A rubber pad should be inserted and a really neat job results. This type of foot requires, however, a small iron or brass plate into which it can be loosely screwed. The feet should be fitted at the four crossing points of the battens. Pocket nets can be obtained from most billiard table manufacturers, and should be tacked in position at each corner, underneath the table and on the top of the corner formed by the sides. Finally, we come to the pocket plates, made from 3/4in. or 1/2in. oak, and cut to shape, as shown in Fig. 8. When you have polished them, clamp one of them firmly down upon the edge of the net at each corner. With the exception of marking, the board is now complete. Measurements and the plan for marking are given in Fig. 9, and should be

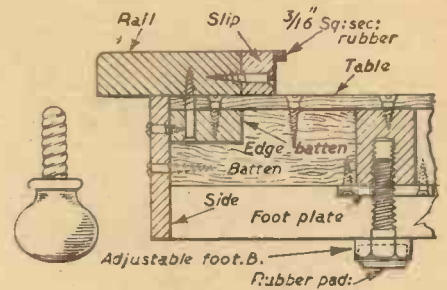

Fig. 7.—Sectional view showing how the rails are attached to the board. The sketch to the left shows an alternative type of foot.

drilled, just large enough to allow the blade to be inserted before cutting along the board.

The Pointers for the Board

After cutting the slots, trim them up with a small flat file, both at the back and front, being careful not to file them wider than necessary, otherwise the pointers which are to be fitted will be too loose. The board should be well glass-papered, stained and polished, setting it aside whilst you prepare the pointers. The material required for these is a piece of thin brass, the thickness of which will allow it to slide freely in the slots. If hard brass is used, care must be taken to bend it against the grain, otherwise it will be found to break at the bend. In Fig. 13 is shown the shaped pointer. Take a pair of tinsmiths' snips and roughly cut across the corner, indicated by the dotted line. Those readers who have had some experience in metal work will find it a simple matter to place all four pieces together, grip them in a vice, and file them up with the aid of a smooth half-round file, but it is advisable for the beginner to do the operation singly. The bend is made next, with the aid of a short rod about 1/4in. diameter. Do not attempt to use a hammer for this purpose: rely upon the strength of your fingers to force the brass round the rod, which is held firmly against it with the thumb of the left hand, whilst the right thumb carries out the shaping. An alternative method is given in Fig. 11 which, however, requires a separate block having a groove that will enable you to press the brass into it between the jaws of a vice. Before inserting the pointer into the slots of the board, the marking figures should be filled in. Transfers can be obtained for these, and the small outlay will save you a heap of tedious work painting them, and will also have a very much better appearance when finished. Assuming that the figures have successfully been applied, you are now able to add the

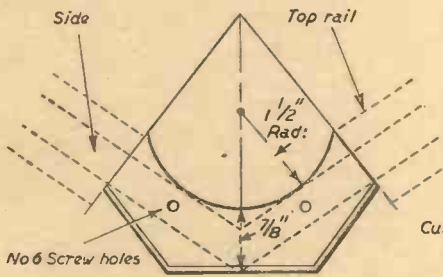

Fig. 8.—Enlarged view of one of the pocket plates.

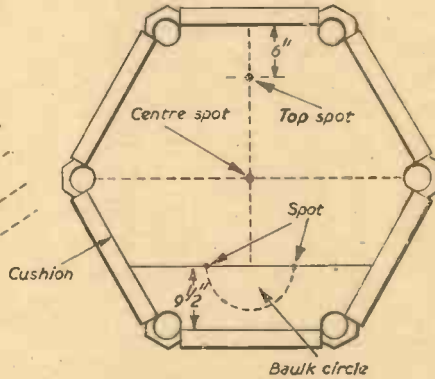

Fig. 9.—A plan view showing how to mark out the table.

will simplify matters if you cut away all superfluous material that is inclined to make the corner appear to sag at the ends. When you have obtained a satisfactory end, tighten the screws before drawing down and tacking underneath. The rails are now attached to the board, as shown in Fig. 7, the screws being long enough to pass through the clearing holes in the deal batten and ply, pulling up into the rail.

Attention can now be turned to the six sides, which serve the purpose of bracing up the whole table. Each side is cut from

made with the aid of a black pencil or thick black crayon, finishing off with the spots cut from a piece of black silk, each being about 1/4in. in diameter.

The Score Board

In Figs. 10 and 12 is shown the board as it is cut from a piece of five-ply. Those readers who have cut the hexagon table from a full-sized sheet of wood will find that one or two spare pieces remain, and it is from one of these that the board can be cut. Select a piece that is nice and flat, and after you have cut it out to the measurements given, drill a hole at either end in order that it may be placed upon the wall when finished. It will be seen that two fine slots are cut along the length, commencing with a hole at the left-hand side. Whether these holes are necessary depends entirely upon the tools that you have at hand. If a fret machine or fretsaw outfit is in your possession, then they are not required. If, however, you have to fall back upon a hack-saw, as used by engineers, they will have to be

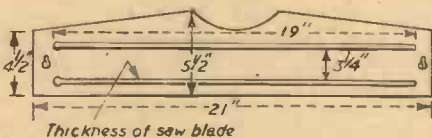

Fig. 10.—How to mark out the scoreboard.

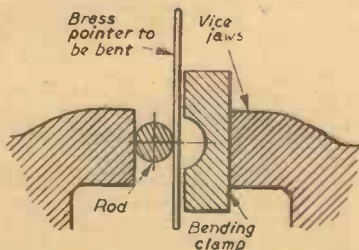

Fig. 11.—Bending the pointer between the jaws of a vice.

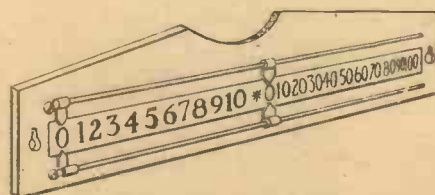

Fig. 12.—The completed scoreboard.

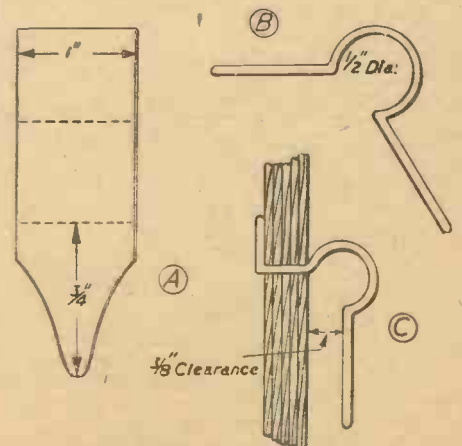

Fig. 13.—How the metal pointer is shaped and fitted.

pointers as shown in Fig. 12, taking care not to make the turn-up at the back too tight—they must be free to slide easily along the figures. Having completed the marking board, here are one or two hints about the game, assuming that you are quite unacquainted with the rules of billiards. In the first place, you will require three balls, two white and one red, 1½ in. in diameter, two cues about 3ft. 6in. long and a spirit level.

Hints on Scoring

The first thing to do when commencing the game is to level up the table by means of the adjustable feet. Apply the level in three or four different positions across the table, raising or lowering the feet until satisfactory. When starting the play, the red ball must always be placed upon the top spot of the table, your opponent retaining his white ball whilst you place your own upon the baulk line or circle at the base of the table. A good starting-off stroke is given in Fig. 14, which will be found quite simple after a little practice. Figs. 15 and 16 also show three other shots well worth trying over. After pocketing the red, it must

always be replaced upon the top spot. The player continues to play until he ceases to score. Should any player pocket his opponent's ball it must remain in the pocket until the player ceases to score, when it is removed and played from baulk. Scoring is as

Four: Pocket both white balls; cannon and pocket white ball; cannon; hitting white ball first and pocketing own ball.

Five: Cannon and pocketing red ball; cannon, hitting red ball first and pocketing own ball.

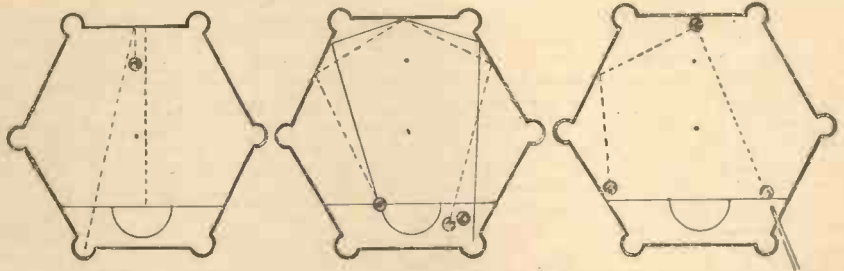

Figs. 14 to 16.—Some useful shots that are well worth practising.

follows:—

Two: Cannon; pocketing opponent's ball; pocketing own ball off opponent's.

Three: Pocketing red ball; pocketing own ball off red.

Six: Hitting red and pocketing both balls; cannon off white on to red and pocket both white balls.

Higher scores can readily be calculated from these figures.

A Folder-binder

A Cheap but Efficient Method of Filing Copies of "Practical Mechanics" By W. J. HARRIS

THE usual method of binding a volume of journals such as PRACTICAL MECHANICS appears to have two disadvantages, viz.: (1) binding cannot be undertaken until the volume is complete;

Construction

The spine of the binder consists of a piece of hardwood 11½ in. long, 1 11/16 in. wide and ¾ in. thick (Fig. 1). Into this, at each end, are driven twelve ¾ in. long panel pins to a depth of ½ in. The panel pins at each end are arranged in two rows of six, the separation between pins being ½ in. and the rows about 3/16 in. apart. The pins of the two rows are staggered as shown in Fig. 2. It is important to use hardwood for the spine in order that the panel pins will not become loosened with use. A piece of cardboard 12½ in. long, 2¼ in. wide and about 1/10 in. thick, is lightly scored with a sharp knife down its length, ½ in. from each edge, and bent to fit closely around the hardwood spine.

with small tacks, an excess ½ in. of cardboard projecting at each end of the spine. Two 1 in.-wide strips of canvas or cloth are then glued to the cardboard sides of the spine. The two covers for the folder, 12½ in. x 8½ in., are also cut from cardboard about 1/10 in. thick, and they, in turn, are glued to the canvas or cloth strips. The folder-binder is now basically complete and the finish is left to individual taste. A quick, pleasing finish is obtained by simply coating with aluminium paint and lettering in black and gold, but the usual book-binding methods of cloth or paper covering can, of course, be applied if preferred.

Method of Use

To insert an issue, it is opened at its middle and placed in the opened folder. A rubber band is then looped around a panel pin at one end of the spine, stretched across

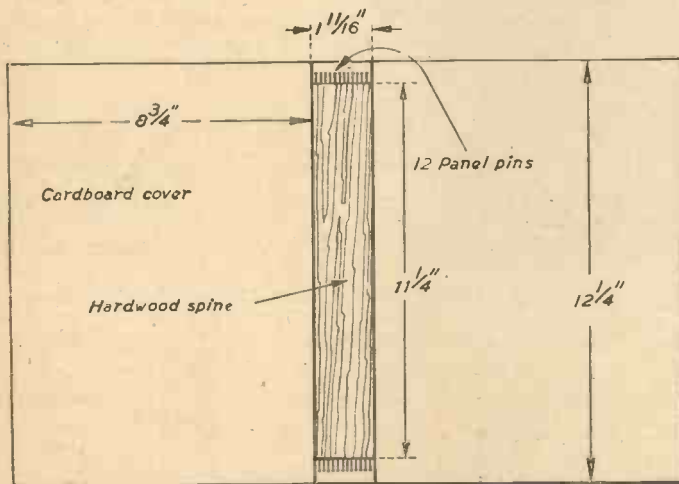

Fig. 1.—The completed binder.

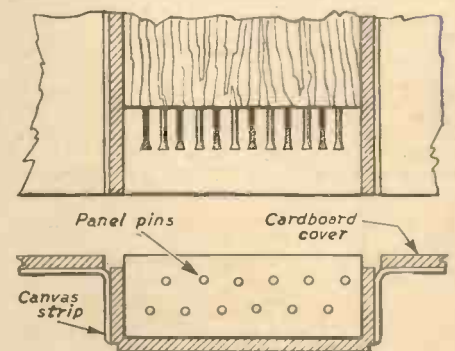

Fig. 2.—Two views of one end of the spine, showing arrangement of panel pins.

and (2) after binding, individual issues cannot be extracted for lending.

With the folder-binder described here, each issue can be inserted and thereby protected as soon as it is bought, and individual issues can easily be extracted and replaced without disturbing any of the others. Each issue is securely held in position by means of a rubber band stretched between two spigots. No. 18 rubber bands (total unstretched length 5½ in.) give optimum results.

The binder can be made in about an hour and at very little cost; indeed, probably at no cost at all, since the materials used are likely to be available in most households.

The cardboard is then fixed to the spine

the issue and looped over the appropriate panel pin at the other end of the spine.

PRACTICAL MOTORIST'S ENCYCLOPÆDIA

By F. J. CAMM.

8th FULLY REVISED EDITION.

A complete and authoritative guide to the principles, upkeep, maintenance and repair of every part of the motor-car. Alphabetically arranged, and cross-referenced.

400 pages, 493 Illustrations. 17/6 or 18/- by post from: GEORGE NEWNES LTD., Tower House, Southampton Street, Strand, W.C.2

A Model Twin-cylinder Oscillating Engine

Constructional Details of the Single-acting Engine as Originally Made for the Model Steam Launch "Vanessa"

By J. E. JANE

THE following details deal with the construction of a twin-cylinder vertical single-acting oscillating engine which ultimately formed part of the power unit for the model steam launch *Vanessa* which was described in the February, 1953, issue of *PRACTICAL MECHANICS*. It was made in general from improvised material lying ready to hand. On test, it came up fully to expectations, and has subsequently proved its worth, with very little attention, since the time of installation in the launch over two years ago.

Before continuing with the description, however, I would like to bring to notice some points which will be necessary to avoid possible slight confusion when comparing the two articles. The engine was actually made some considerable time before the launch,

Constructional Details

The mounting standards (Fig. 2) were made from 18G. sheet iron. Two pieces $4\frac{1}{2}$ in. x $3\frac{1}{2}$ in. were soldered together, and the shape marked on, together with the positions

Fitting the Ball-races

The normal method here is to turn up the required socket to accept the "race" as a push fit. Having no lathe, this was out of the question, so fitting by hand was

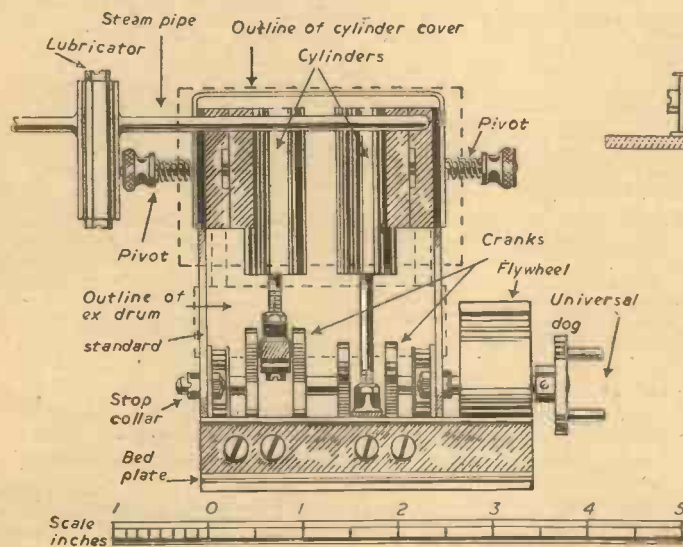

Note. In these two views some of the engine parts have been omitted for clearness.

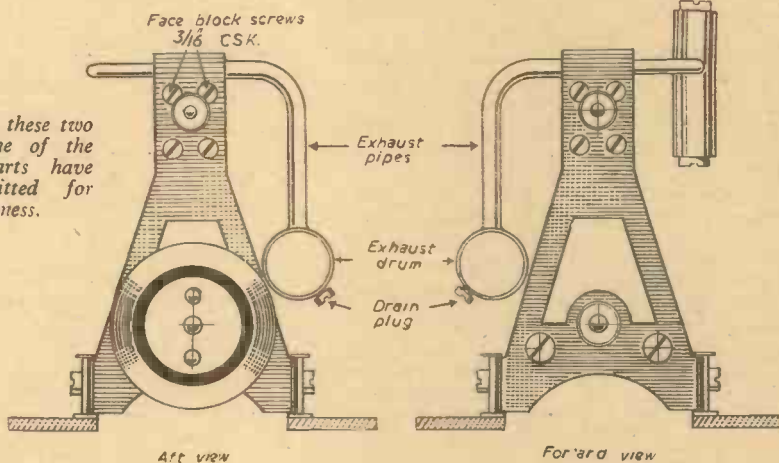

(Above) Fig. 1a.—End elevations, showing the positions of the exhaust drum and lubricator.

(Left) Fig. 1.—Side elevation of the completed engine.

carried out as follows: First, two brass plates were cut and made to fit crosswise on the mountings as shown in figure 3. To these plates were silver-soldered $\frac{1}{2}$ in. dia. brass collars. The holes were scraped out until the races all but entered, then, using the vice as a press, they were eased into position. To make sure of them "staying put" the collars were filed flush with the edge of the race-bands, and then fitted with overhanging washers held in position with two 8 B.A. screws (Fig. 3).

Bed Plates

Two short lengths of brass curtain rail were cut and each brazed on to lengths of brass strip $1\frac{1}{2}$ in. x $3\frac{1}{2}$ in. x $\frac{1}{8}$ in. thick (Fig. 4). After cleaning and filing, $\frac{3}{16}$ in. holes were drilled where necessary to accept the bedding down, and mounting standard bolts.

and the illustrations here display its design at that time. It has since, however, been slightly modified, and the illustration shown in Fig. 6 (March, 1953, issue of P.M.) shows its present form. The motion and the main construction remain exactly the same, and only superficial details were modified. These were as follows:—

1. Condenser drum removed — not necessary.
2. Steam and exhaust pipes rearranged—more satisfactory.
3. Lubricator centralised.
4. Driving "dog" removed and the "pegs" fitted to flywheel instead.
5. Removal of engine cover.
6. Bed plates filed down to remove unnecessary metal.

Modifications 1, 4, 5, and 6 were carried out in order to make the engine lighter. I might add, however, that the engine can be fitted as originally made, but the builder in this case would have to decide upon his own position for the steam regulator, and for a suitable exhaust pipe to lead to the funnel from the condenser drum. The engine cover can be left on if so desired, as it carries out its function very well, but, apart from removing it to help lessen the weight, it did prove a bit of a nuisance when it was necessary to get at the cylinders for any reason.

for the main bearing and screw holes, etc. The shape was then cut out with the hacksaw, drilled as necessary, and filed up smooth.

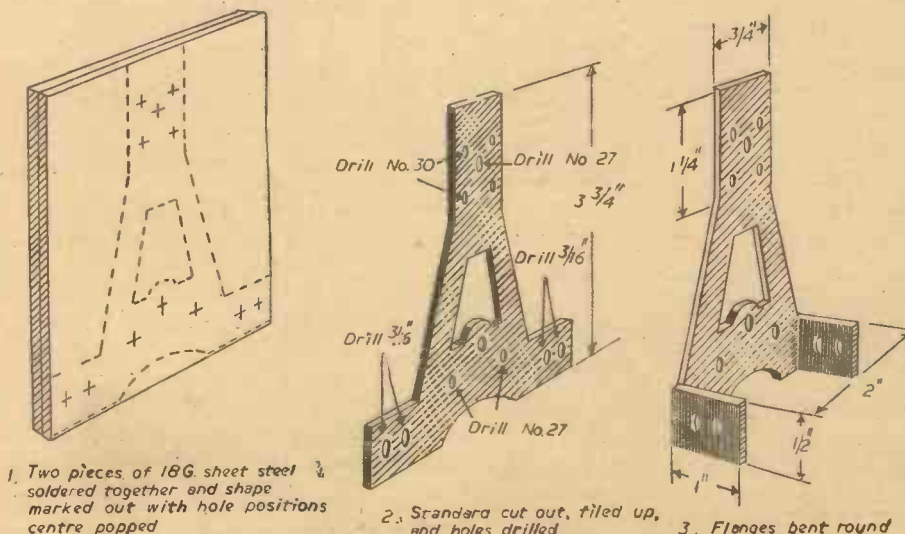

1. Two pieces of 18G sheet steel soldered together and shape marked out with hole positions centre popped

2. Standard cut out, filed up, and holes drilled

3. Flanges bent round

Fig. 2.—Details of the mounting standards, showing how they are marked out and cut from sheet steel.

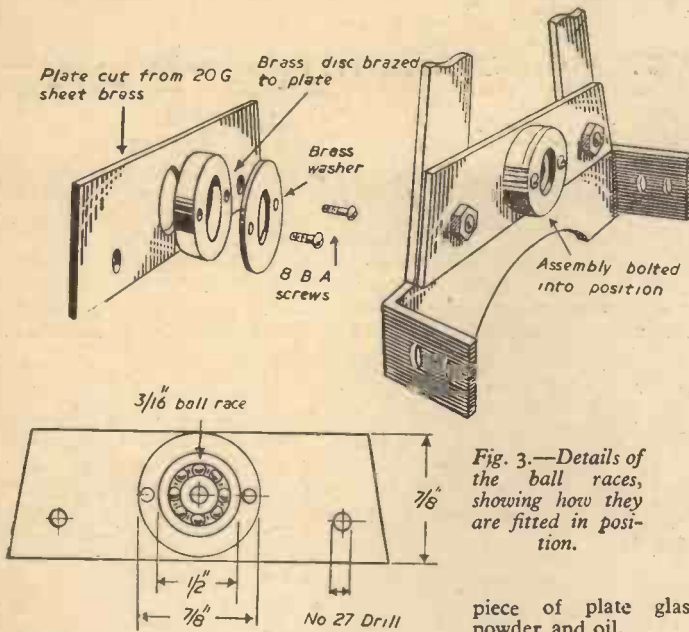

Fig. 3.—Details of the ball races, showing how they are fitted in position.

These are cheese head brass, 4 B.A., for the standard, and 3/16in c.s.k. for the bed plates. (Bed plates are later filed to the shape, as shown in Fig. 6—Vanesa article.) The standards slide into, and were fixed in, the channel rail, as shown in Fig. 1 and 1(a).

Face Blocks

Four brass blocks were cut and filed to the following dimensions: 1 1/4in. x 3/4in. x 3/4in. These were then drilled at centres with a No. 33 drill, and the subsequent holes treated as follows: on the two blocks for the standards they were opened out with a No. 27 drill, and on the cylinder blocks they were tapped 4 B.A. to accept the pivot rods which were fashioned from 5/32in. dia. M.S. (Fig. 5). The standard blocks each have an anti-friction recess filed in them 3/8in. wide x 1/32in. deep. The cylinder blocks are filed half round on one side to form a seating for the cylinders. At the final stages, after drilling the steam and exhaust ports, both sets of blocks had their working surfaces levelled and polished on a

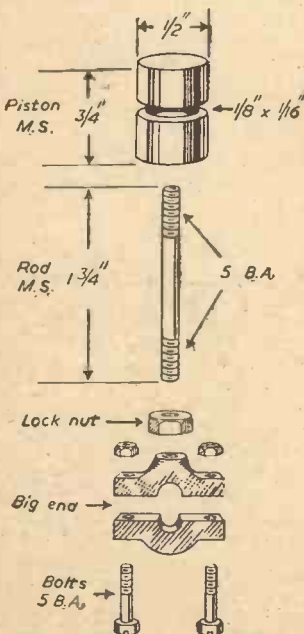

Fig. 6.—Details of a piston, piston rod, and big end.

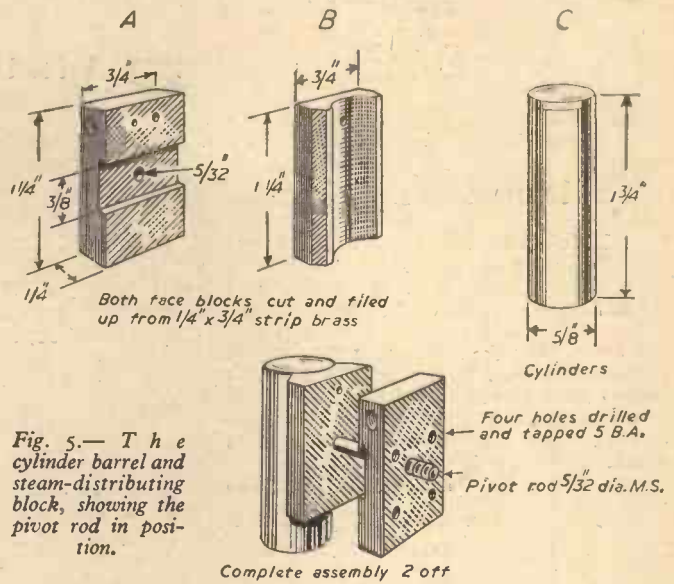

Fig. 5.—The cylinder barrel and steam-distributing block, showing the pivot rod in position.

piece of plate glass with carborundum powder and oil.

Cylinders

Two pieces of 3/8in. dia. brass tubing were cut to 1 1/4in. lengths, and the 1/2in. bore

Pistons and Piston Rods

The pistons consist of 3/4in. lengths of 3/4in. dia. mild steel lapped into the cylinders. Around each piston was filed a groove 3/8in. wide by 1/16in. deep. These were packed with asbestos string soaked in oil. Right

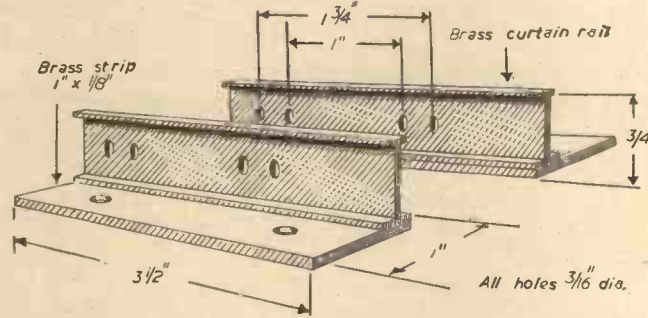

Fig. 4.—Perspective view of the divided bed plate, showing the position of the channel rails to which the engine standards are bolted.

slightly reamed out to fit the pistons. Two pieces of 20g. brass formed the cylinder heads, these being brazed into position, then filed off smooth and flush with the cylinder barrels. The cylinders were then fitted to their respective blocks, bound with wire, and sweated into position with soft solder. The final operation was to drill the steam ports, as in Fig. 5.

through the centres were drilled 3/8in. dia. holes, which were afterwards tapped 5 B.A. (Fig. 6).

The piston rods were made from 3/8in. dia. M.S., and after threading one end of each 5 B.A., they were screwed well home into the pistons and "fixed" with soft solder. The other ends of the rods were then threaded 5 B.A. for insertion into the big ends.

Big Ends

These were made from 5/16in. square brass rod. Pieces 2in. long were soldered together, then, with an interval of 3/4in., two 3/16in. dia. holes were drilled through at the join, thus ensuring two correct curves on each section. After cutting to the required size, the tops were drilled and tapped at centres, 5 B.A. to fit the piston rods, and on either side, with sufficient clearance to bypass the main bearing holes, two more holes were made with a No. 30 drill to fit 5 B.A. nuts and bolts. The blocks were filed to shape, as shown in Fig. 7, unsweated, cleaned up, and fitted to the piston rods, locknuts being fitted to each.

(To be continued)

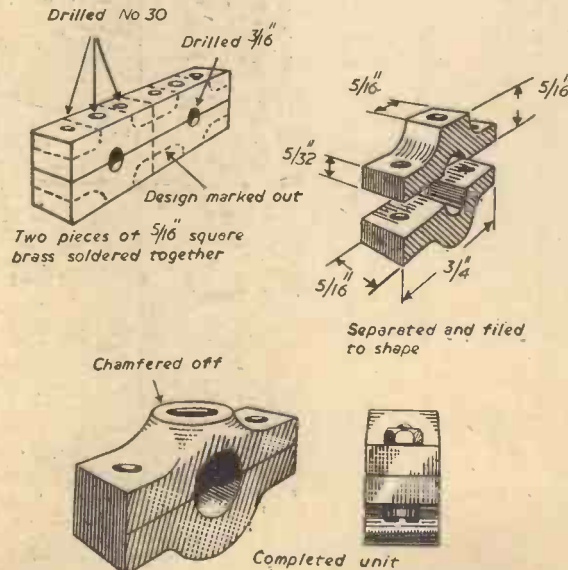
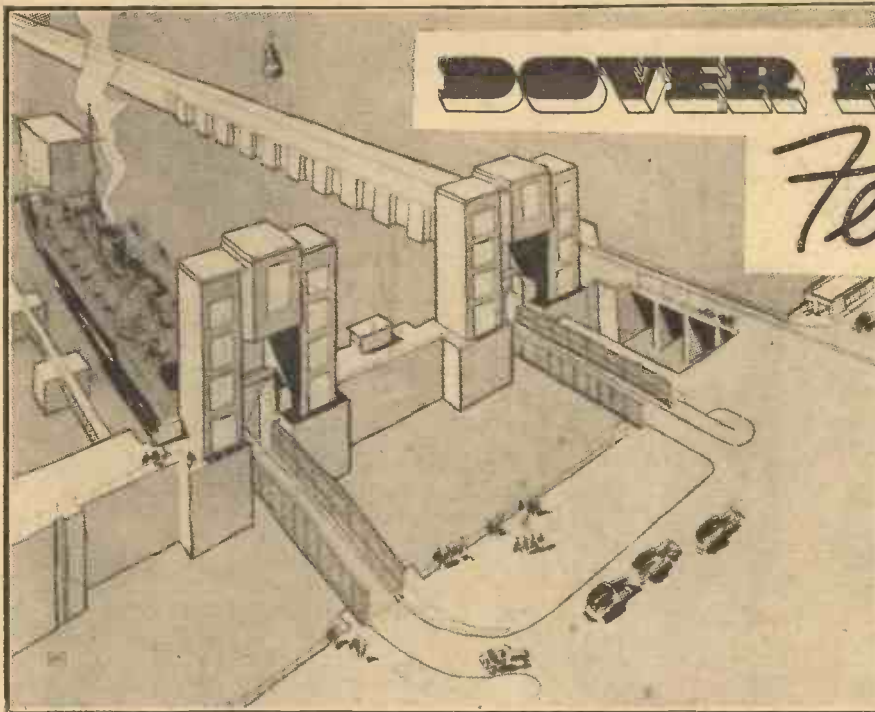

Fig. 7.—Method of cutting out the big ends from one piece of brass.

Model Boat Building
 BY F. J. CAMM
 5/-, by post 5/6
 From GEORGE NEWNES, LTD.,
 Tower House, Southampton St., Strand, W.C.2



A view of the loading bridges and portals.

DOVER HARBOUR

Ferry Bridge

Details of the Operating Mechanism of the New Vehicle Ferry Bridge at Dover Harbour

sets of controls, one for each of the two bridges which form the dual installation. For normal working the operator in his control cabin can watch the loading of two ships, but action is required from him only when the ships are leaving or arriving.

In the normal operation of the bridge from its stowed position the manual controller is used to lower the bridge until the ramp touches the ship's deck. The "automatic" control is then switched on, and thereafter, if by movement of the tide or swell the stern of the ship rises more than 3in. from the neutral position, the angular change of ramp to bridge actuates a switch which sets in motion contactor gear controlling the hoisting mechanism and the bridge starts moving in the upward direction. This movement in turn causes angular change between the bridge and the ramp and motion continues until the bridge and ramp are back in their original relative angular position, when a second switch opens the contactor gear and stops further movement of the bridge. Similar switch arrangements are provided to deal with downward motion of the ramp from its neutral position, and these automatic adjustments function continuously, causing the bridge to rise or fall whenever the vertical movement of the ship exceeds

IN the age when it was the custom to load ships by porters carrying loads on their backs, no practical difficulty was encountered due to the rise and fall of the vessel relative to the loading berth, either by tides or due to the difference in draft of the vessel when light and when loaded. With the development of mechanical loading appliances the flexible connection to overcome these differences in level between shore and ship has most frequently been formed by cranes, as these by their character have the facility of loading at one height and unloading at any other desired height.

As mechanical transport has become more and more common, attempts have been made to load ships by running wheeled vehicles direct into the ship's hold, and a specialised form of this is met with in vehicle ferries. Where the shore is open and a natural ramp can be constructed no difficulty is experienced, nor with docks where there is only a small rise or fall of tide as it is a simple matter to arrange a short inclined ramp to bridge the gap between the quay and ship, but where there is a substantial rise and fall of the tide other means of loading and unloading have had to be adopted. Ferries have been fitted with raisable decks, which are raised or lowered to suit the quay level at various tides. Long ramps from quay to ship have relied on a vertical cage lift at the end to compensate for tidal fluctuations, but in many cases where there is a substantial tide variation cranes are still used as a means of hoisting vehicular transport aboard ship.

On account of the intermittency of the crane cycle and the bulky character of modern transport this has been a slow and not entirely satisfactory means of loading. Anybody who has stood on the quay watching their treasured motor car being hoisted aboard ship can well understand the feelings of a Continental bus operator in a similar situation.

Ramp 140ft. Long

At Dover Harbour, one of the terminals of the cross-channel traffic, the rise and fall of the tide can be as much as 18ft. 9in. and it can be well appreciated that the length and weight of a ramp necessary to accommodate this rise and fall becomes much too great

to simply support the end of the ramp on the deck of the ship. The new car ferry installation, which has recently been opened at Dover, has a ramp 140ft. long, weighing not less than 280 tons and the problem of supporting the ship end of this ramp has been solved by attaching the end of the ramp to hoisting mechanism which is actually controlled automatically by the movement of the ship itself. If the ship rises with the tide or swell, this movement automatically causes the end of the bridge to be hoisted by an exactly corresponding amount. The ingenious arrangement which has been adopted is shown in the illustration on page 62.

The main ramp takes the form of a bridge mounted in pivots at the landward end and suspended at the other by means of ropes leading over pulleys at the top of a reinforced concrete portal and thence to a hoisting mechanism. A short ramp is hinged to the end of the bridge and the end of this ramp rests on the ship's deck. As the ship rises and falls with the tide it causes angular movement of this ramp about its hinges on the bridge and this movement is used to make and break a series of switches which operate the bridge-hoisting mechanism. Manual controls are provided for moving the bridge to its stowed position when ship unloading is completed.

Automatic Controls

The main controls are grouped together in a cabin at the edge of the quay, there being two independent



The first car to use the new car ferry terminal was driven by Mr. Lennox-Boyd, Minister of Transport, who opened the new terminal recently.

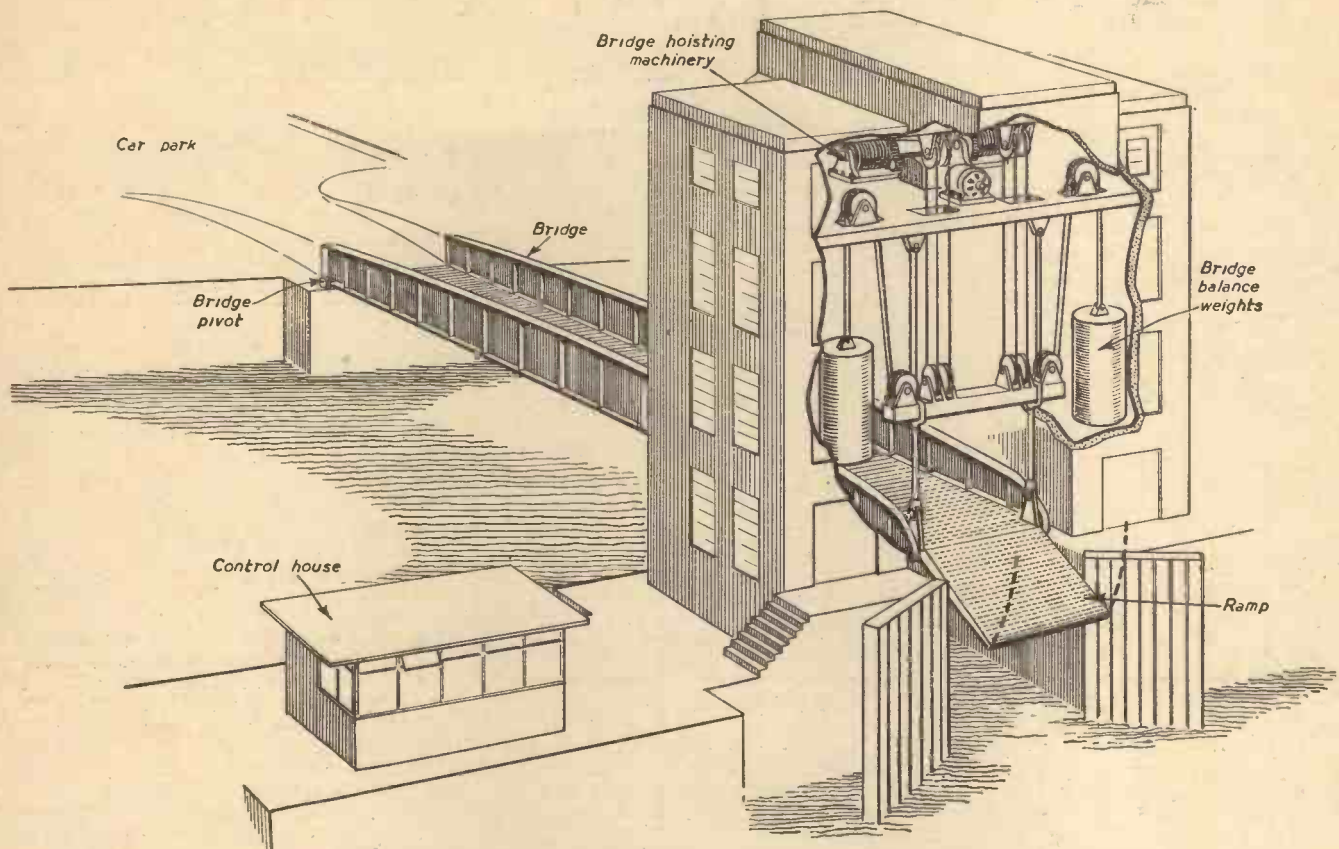

A diagrammatic sectional view showing the hoisting mechanism for one of the ferry bridges.

3in. A second set of switches is available so that by selection the dimension of 3in. can be changed to 6in., the choice depending on weather conditions. This arrangement permits a constant close relationship of bridge to ship, and a continuous passage of traffic from shore to ship without the pause for supervision which would be necessary if manual adjustment of the bridge to the ship was relied on.

it is not in use the automatic control can be isolated and an independent hoisting mechanism operated by manual control by which the ramp is raised to its vertical "stowed" position.

The whole arrangement thus constitutes a safe and continuous means of contact

between ship and shore, permitting the high rate of flow of vehicles, 200 of which per hour can pass through the customs shed. The installation is another step in the development of Continental traffic and another nail in the coffin of the nearby project for a cross-channel tunnel.

Counterbalance Weights

To simplify the hoisting mechanism two large balance weights are fitted to counteract the weight of the bridge when empty of traffic. These balance weights are suspended by wire ropes, as shown in the illustration, the multipart rope system being provided to minimise the size of rope necessary. The hoisting load is carried on a dual system of multipart hoisting ropes, thereby keeping the diameter of hoist rope and drums within reasonable dimensions. Owing to the system of balance weights the hoisting motor can be quite small as it has only to deal with the additional load caused by the traffic on the bridge.

As with all automatic mechanical arrangements, safety precautions have to be provided in case of failure. Safety limit switches and cut-outs, therefore, are arranged both on the ramp and the bridge to prevent excessive hoisting or lowering. In view of the need to ensure that there should be no traffic hold-up special provision has also been made to minimise delay in case of a breakdown. An emergency diesel generator set has been provided for use in case of a failure of the mains supply, and even the driving motor has been duplicated so that in the event of a failure of the motor a new motor can be switched into circuit without delay.

The ramp at the end of the bridge overhangs the water, and to avoid damage when

An Automatic Copying Machine

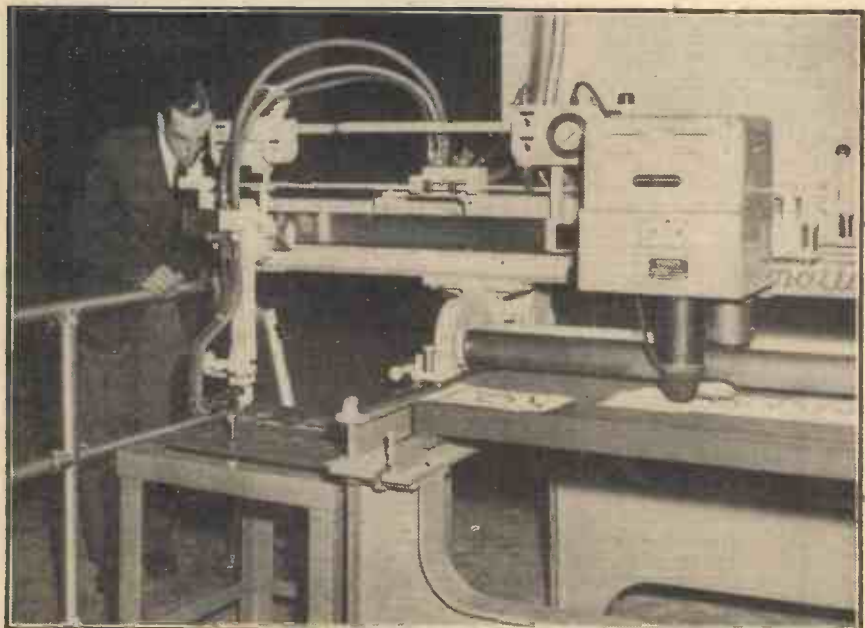

In this automatically controlled machine, seen recently at the Radio Show at Earls Court, a pointer traverses a drawing and reproduces a replica on sheet steel.

BRASS CASTING AT HOME

A Simple Method of Casting Brass Bar From Scrap Metal

By M. H. O. HODDINOTT

ALL amateur model engineers to-day know the high price of bar and sheet brass, and it is for this reason that I decided to cast my own bar; for obvious reasons it is almost impossible to produce sheet brass.

Brass in scrap form is plentiful enough, broken screws, old lampholders, old alarm-clocks and even knobs off bedsteads are a common source of supply, but in a usable bar form it becomes a costly item. With the method

has an inside diameter of 6-in. leaving about $\frac{3}{8}$ -in. all round between it and the fireclay lining. Other sizes of crucibles can be bought to suit any other size of stove, but I think the 5 x 4 size is the most convenient to handle.

Moulds

Up to date, I have tried only round moulds and these I have made from short pieces of iron pipe. I have, at present, three, the inside diameter being $\frac{3}{8}$ -in., $\frac{3}{4}$ -in. and $1\frac{1}{2}$ -in.

As will be seen from the diagram (Fig. 3), the mould is made up by obtaining a short length (about 6-in.) of iron gas piping having a thread at one end, and a base made up of a threaded ring welded to the base plate. The base plate is $\frac{1}{8}$ -in. mild steel. By this means the piping can be screwed into the threaded ring until its end comes up against the base plate. A flush fit here is important otherwise when the brass is poured in it will spread out underneath and the removal of the casting will be more difficult.

The base plate itself serves both as a means of keeping the mould upright and as a plug for the bottom end. All burrs should be removed from either end of the pipe and the threads lubricated with graphite.

Method of Casting

Fill the crucible up with scrap brass and place it on the hot coke bed (the stove should only be half full). When it is in position drop more coke around the crucible until it is firmly seated in position and now buried up to its top in the fuel. Close the top lid and front charging door and open fully the bottom ash door. This will cause all the chimney draught to pass through the coke bed and increase the heat.

up ready for receiving the brass. To remove the crucible a pair of long tongs, made from $\frac{1}{2}$ -in. iron tube are advisable as the crucible can be handled easily and comfortably this way. Details of the tongs are given in Fig. 4.

Pouring

Having collected and removed all the dross and borax to one side, lift the crucible out of the stove and pour its contents as rapidly as possible into the mould, filling it to overflowing to allow for contraction. No borax should be allowed to accompany the brass into the mould otherwise the metal may "wet" the iron tube and braze itself solid.

The mould and its contents may now be

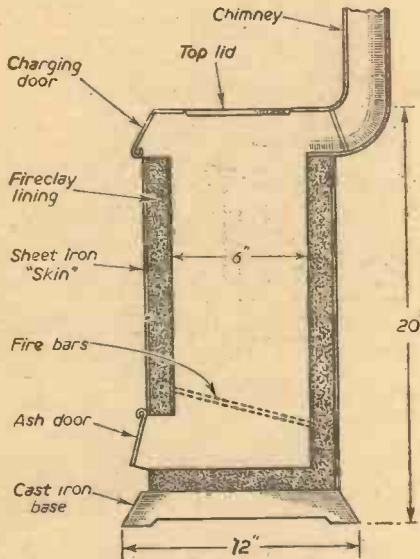

Fig. 1.—Sectional view of the stove.

described below I have become independent of outside sources for the round bar. I have not yet tried square bar, but I see no reason why that should not be equally straightforward to cast, once the mould is made.

The Stove

The source of heat for my casting is a very small round iron coke stove, the dimensions of which are given in the diagram, Fig. 1. It has a straight iron pipe, 4-in. inside diameter and 7-ft. long, for the chimney, which passes up through the roof of my garden workshop. This particular type of stove is commonly seen in ironmongers and has the advantage of a removable lid on the top—a necessity for removing the crucible.

Although they are not usually fitted with firebars, I found by wedging a small piece of ordinary household firebar across the bottom of the inside of the stove just above the ash door the stove burnt much better and hotter. I should mention here that casting is a little heavy on the firebars and they rapidly corrode away, but if you have one "session" making a stock of bar on other occasions when the stove is used only for heating it can be well damped down to preserve them.

Crucibles

The best crucibles for the purpose are plumbago ones made by the Morgan Crucible Co., Ltd., London. They are available in several sizes—the one I use is 5-in. high and 4-in. across the top (Fig. 2). They are very resistant to thermal shock and can be placed safely directly on to the hot coke without risk of cracking. Furthermore they are easily scraped down for cleaning. The size quoted above will just fit my stove which

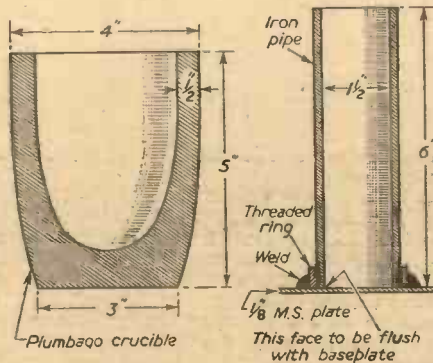

Fig. 2.—Section of the crucible.

Fig. 3.—Details of the mould.

After a short time—a quarter to half an hour depending on temperature and type of brass—the charge will melt and at first sight it will appear very dirty, but by stirring it with an iron rod the bright shining surface of the true metal will be seen under the dross. If heating is taken too far some of the zinc in the brass will burn off as brilliant blue green flashes of flame bursting from the metal. When all has melted throw in about one tablespoon of dehydrated borax powder which will melt into a sticky mass on the surface of the metal and collect together all the dross; if possible this dross should then be removed. While doing this, preheat the mould to a dull red heat and set

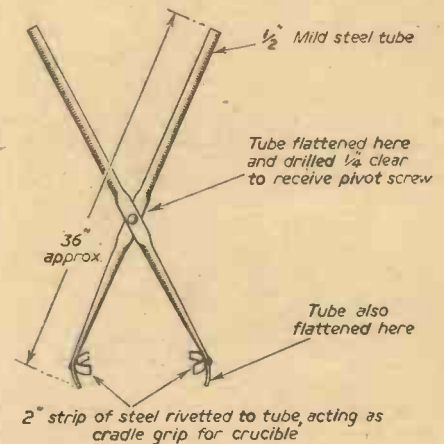

Fig. 4.—The tongs are made from iron tubing.

plunged into cold water to cool and the base plate screwed off. Owing to the large contraction of brass compared with iron it will be found comparatively easy to tap the casting out from the mould, from the base end. I have found that on a 6-in. long casting I lose about $\frac{1}{8}$ -in. at the filling end due to contraction, but otherwise the casting is perfect. Narrow diameter moulds are easier to start on as the larger diameters have more tendency to gather dross, air bubbles, and to laminate, unless poured with great rapidity.

Readers will realise that the castings are rough and require machining before useful work can be done with them. Most of the rough gas piping available has a jointing rib down the inside and this tends to form a trough down the castings. If possible seamless tube or machined tube should be used to get the best result.

PRACTICAL MECHANICS
HANDBOOK

By F. J. CAMM

12/6, or by post 13/-.

Obtainable from booksellers, or by post from George Newnes, Ltd. (Book Dept.), Tower House, Southampton Street, Strand, W.C.2.

Back to First Principles

10—Overcoming Distances

By W. J. WESTON

WE cannot define matter; but we know one thing about it. Force is always requisite to start matter from rest, or to stop matter in motion. This universal property of matter is *inertia*. Applied force may make the matter move through space at a speed. That is, force may overcome inertia, and in moving a mass may overcome distance. Speed and distance present interesting problems.

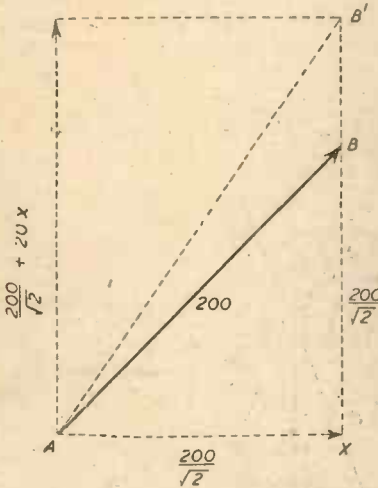

Fig. 1.—A problem of flying.

The Problem

A helicopter that travels at 80 miles per hour in still air starts from A to go to B, which is 200 miles distant N.E. of A. If there is a wind blowing from the north at 20 miles per hour, determine the direction in which the helicopter must move and the time needed.

If at the end of an hour the wind drops to five miles per hour, determine the position relatively to B of the helicopter at the time when it should have reached B.

Show that, provided that the velocity of the wind remains fixed in direction and magnitude, all points attainable by an aeroplane in a given time lie on a circle whose radius is independent of the wind.

The Comment

That is a threefold problem inviting you to consider some of the problems of flying. The diagram (Fig. 1) will help you. In order to cope with the wind, the helicopter aims at a point B' north of B. You resolve the velocity into two components, eastwards and northwards. The eastwards component will be $\frac{200}{\sqrt{2}}$ miles, since ABX is an isosceles right-angled triangle and AB is 200 miles. The northwards component would also be $\frac{200}{\sqrt{2}}$ miles in still air,

but it must be augmented to cope with the 20 miles an hour wind over x hours. That is, it will be $(\frac{200}{\sqrt{2}} + 20x)$ miles. The resultant of the two components is AB', which is 80x miles. So you have the equation:

$$(80x)^2 = \left(\frac{200}{\sqrt{2}}\right)^2 + \left\{\left(\frac{200}{\sqrt{2}}\right) + (20x)\right\}^2$$

The wind having dropped the flyer will, unless he alters course, overshoot B: he will be too far north by $(x-1)$ hours \times 15 miles.

The diagram (Fig. 2) establishes the proof needed.

The Answer

$$(80x)^2 = \left(\frac{200}{\sqrt{2}}\right)^2 + \left\{\left(\frac{200}{\sqrt{2}}\right) + 20x\right\}^2$$

$$\text{i.e., } (4x)^2 = \left(\frac{10}{\sqrt{2}}\right)^2 + \left\{\left(\frac{10}{\sqrt{2}}\right) + x\right\}^2$$

$$\text{i.e., } 16x^2 = 50 + 50 + 10\sqrt{2}x + x^2$$

$$\text{i.e., } 15x^2 - 10\sqrt{2}x = 100$$

$$\text{i.e., } x^2 - \frac{2\sqrt{2}}{3}x + \left(\frac{\sqrt{2}}{3}\right)^2 = 20 + \left(\frac{\sqrt{2}}{3}\right)^2$$

$$\text{i.e., } x - \frac{\sqrt{2}}{3} = \frac{\sqrt{60+2}}{9}$$

$$\therefore x = 3.096$$

Time taken \therefore = 3 hours 5.76 minutes.

Sine of $\angle XAB'$ is $\frac{XB'}{AB} = .8210$

$\angle XAB \div$ is $55^\circ 11'$

Direction \therefore is $34^\circ 49'$ cast of north.

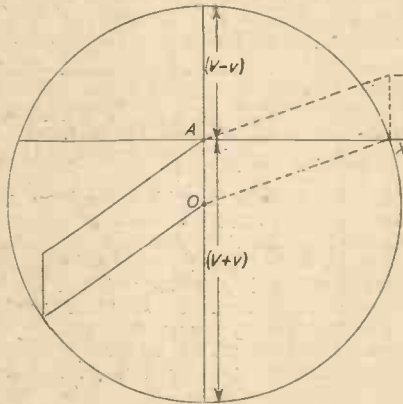

Fig. 2.—The proof.

(2) Overshooting of B by reason of drop in wind velocity of 15 miles an hour after 1 hour is $15 \times 2.096 = 31.44$ miles north.

(3) Suppose A the starting point, V the speed of the aircraft in still air, and v the speed of wind, and assume that the wind blows from the north.

Then an hour's flight north is $(V-v)$
Then an hour's flight south is $(V+v)$
O, south of A by v, is midway; and O can be shown to be the centre of the required circle.

Thus, a flight to a place X east of A would need a north component of v. Join X with O and we have a parallelogram. Moreover, in whatever direction the flight took place a parallelogram would also be produced. With OX as radius describe a circle: all points on

the circle would be reached from A in the same time.

The Problem

A cruiser that can steam at 30 knots receives a report that an enemy vessel, steaming due north at 20 knots, is 29 nautical miles away in a direction 30 deg. north of east. When will the cruiser overtake the vessel? (A knot is a speed of 1 nautical mile per hour.)

The Comment

That is the kind of problem that Captain Horatio Hornblower delighted to solve in practice. You can solve it graphically on squared paper, giving one square to a nautical mile. Calculation will test the accuracy of your drawing.

The Answer

Suppose x to be the number of hours in the pursuit.

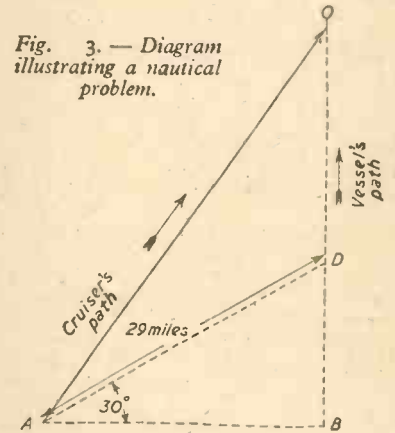

Fig. 3.—Diagram illustrating a nautical problem.

Then AO (Fig. 3) = 30x nautical miles
DO = 20x nautical miles
Since $\angle BAD$ is 30° , then $BD = \frac{1}{2}AD = 14\frac{1}{2}$ nautical miles.

Therefore BO = $(14\frac{1}{2} + 20x)$ nautical miles

And AB = $(29 \times \frac{\sqrt{3}}{2})$ nautical miles.

In the right-angled triangle ABO, $(AO)^2 = (AB)^2 + (BO)^2$

That is:

$$(30x)^2 = \left(29 \times \frac{\sqrt{3}}{2}\right)^2 + (14\frac{1}{2} + 20x)^2$$

That is:

$$900x^2 = \frac{2223}{4} + \frac{741}{4} + 5802 + 400x^2$$

That is: $500x^2 - 580x = 741$

That is:

$$x^2 - \frac{29}{25}x + \left(\frac{29}{50}\right)^2 = \frac{741}{500} + \left(\frac{29}{50}\right)^2$$

Extracting square root:

$$x - \frac{29}{50} = \frac{66.7}{50}$$

Time taken is, therefore, just short of two hours.

BOOKS FOR ENGINEERS

By F. J. GAMM

- Screw Thread Tables, 5/-, by post 5/3.
- Refresher Course in Mathematics, 8/6, by post 9/-.
- Gears and Gear Cutting, 6/-, by post 6/6.
- Workshop Calculations, Tables and Formulae, 7/6, by post 8/-.
- Dictionary of Metals and Alloys, 10/6, by post 11/-.
- Wire and Wire Gauges (Vest Pocket Book), 3/6, by post 3/9.

- Newnes Metric and Decimal Tables, 3/6, by post 3/9.
- Practical Mechanics Handbook, 12/6, by post 13/-.
- Slide-rule Manual, 5/-, by post 5/3.
- Mathematical Tables and Formulae, 5/-, by post 5/3.

Published by
GEORGE NEWNES, LTD., TOWER HOUSE,
SOUTHAMPTON STREET, STRAND, W.C.2

Glass-working for Beginners

The Properties of Glass, and the Simple Tools and Processes Used for Working It

Closing the End of a Tube

IN order to close the end of a tube, the following procedure should be adopted: A length of tubing somewhat longer than the final length is taken. If a number of closed tubes are required, it saves material to take twice the required length and form two tubes at the same time. The tube is heated in a large blue flame (rotating continuously) and, when quite soft, drawn out as in Fig. 11(a). The fine bore tube formed should be between 12in.-18in. long. This fine capillary tube can be broken at approximately its mid-point by bending (care being taken that it is held well away from the face). The tapered end is now heated in the flame in the position shown in Fig. 11(b), and the fine tube drawn away as soon as it is soft enough. The remaining operation is to round the end of the tube. This is done by heating the end of the tube until it is soft; the tube is then applied to the mouth and a few short and gentle puffs are given, rotating the tube between each puff. When completed, the end should appear as shown in Fig. 11(c). Figs. 11(d) and 11(e) show incorrectly finished ends. These ends will not withstand pressure or shocks efficiently. Tubes with closed ends can be used for a variety of purposes. One useful application is that of holding garden labels. In this case the tube should be about 6in. long (dia. 5 mm.). The label is written with indian ink on a slip of paper and pushed into the tube. The open end of the tube can be sealed with a small cork and then dipped in molten paraffin wax (candle), or, if a more permanent label is desired, the end of the tube can be drawn-off. In the latter case, sufficient length of tube must be left above the label to prevent it from being charred during the drawing-off operation. Fig. 12 gives details of such labels. In use,

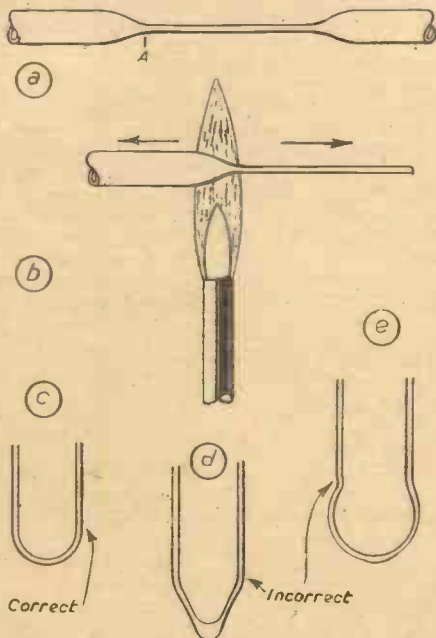

Fig. 11a.—The tube after drawing. b. Position of tube in flame for removing fine tube. c. End correctly finished. d & e. Incorrectly finished ends.

By E. HARRIS MORGAN, B.Sc.

(Continued from page 12, October issue)

they should be pushed well into the ground to prevent them from being mistaken for worms by inquisitive birds.

Small diameter tubing does not require annealing after the process, but annealing



Blowing a bulb. (Note position of the hands. When heating the tube in preparation for blowing, the back of the left hand and the palm of the right hand should be uppermost, so that the tube can be swung quickly into position for blowing.)

must be carried out for tubing of greater diameter than about three-eighths of an inch.

This process may also be employed in the construction of barometer tubes (thick-walled tubing) and test tubes (thin-walled tubing).

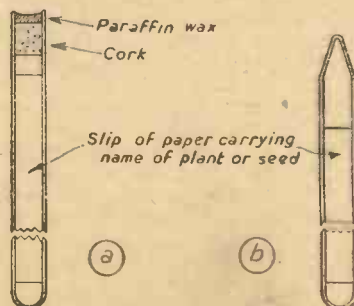

Figs. 12a and b.—Glass tubes for garden labels.

Forming Jets

If it is desired to form a jet, the process of closing a tube can be stopped at an intermediate stage. The tube is drawn-off exactly as previously described. It is then cut with a file in the normal manner at the point A in Fig. 11(a) and the end of the tube fire-polished. Care should be taken here to ensure that the end of the jet is held in the flame only long enough to be polished. If a smaller jet is required, the end of the tube can be collapsed in the flame to the desired size.

The bending of glass tubing is an operation which calls for a certain amount of skill and judgment which can only be acquired by repeated practice. Different techniques are applicable to tubes of different diameters, and these will now be discussed in detail.

Small Diameter Glass Tubing

This section includes glass tubing up to an external diameter of about three-eighths of an inch. The tubing is heated in the flame of a batswing burner, the size of the flame being adjusted so that it is about four times as wide as the diameter of the tube for bends up to a right angle, and about six times as wide as the diameter of the tube for bends greater than a right angle. When the tube is soft it is allowed to bend under its own weight, final adjustments for angle and alignment being made after the tube has been withdrawn from the flame. The bend must not be forced, neither must the tube be brought to too high a temperature. It is easy with a little practice to obtain the desired angle, but the aid shown diagrammatically in Fig. 13 may be employed. This takes the form of a chart pinned to the wall at eye-level, in front of the bench. Some standard angles are marked on the chart. If an angle not shown is needed, a new chart can be prepared quickly and pinned in its place. After bending the tubing, and before it has cooled, it can be held up and compared

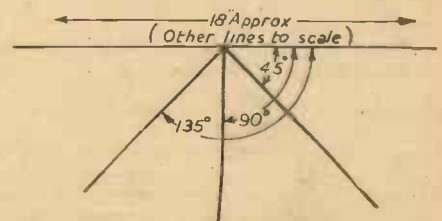

Fig. 13.—Bending chart.

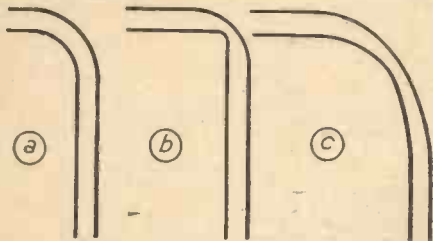

Fig. 14a.—Correctly formed bend. b. Incorrect bend due to using too narrow a flame. c. Incorrect bend due to using too wide a flame.

with the angles drawn on the chart, and any final adjustments carried out. Tubing of this size does not require annealing after bending. If the operation has been carried out correctly, the bend will have the appearance of that shown in Fig. 14a. Figs. 14b and 14c show defective bends produced by incorrect technique. The bend shown in Fig. 14b has been produced by using too narrow a flame, and that shown in Fig. 14c by using too wide a flame. The shape of 14a can also be produced by forcing the tubing into a bend before it is soft enough.

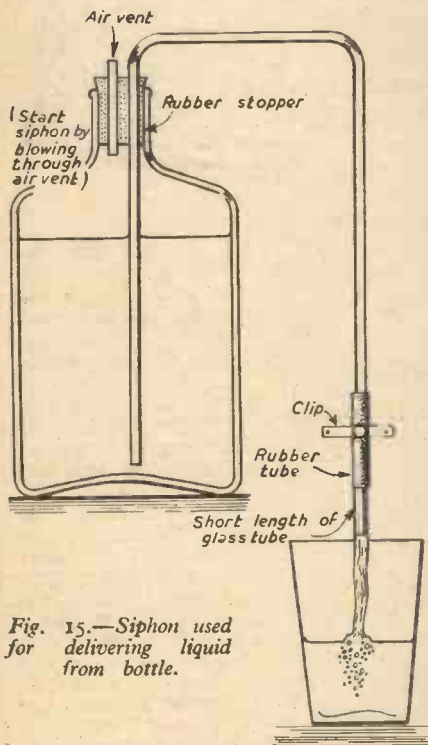

Fig. 15.—Siphon used for delivering liquid from bottle.

A U-bend can be produced by continuing to bend until one end of the tube has been bent through 180 degrees, remembering in this instance to heat a greater length of tube.

An inverted U-bend may be used as a siphon, and finds application in photography, for draining film or plate-washing tanks from the bottom.

Siphons can also be used to deliver chemicals from bottles, as shown in Fig. 15.

Medium Diameter Tubing

This section includes tubing from about $\frac{3}{16}$ in. diameter up to about $\frac{1}{2}$ in. diameter. The tubing is bent in the flame of a batswing burner and the procedure is the same until actual bending takes place. Tubing of this diameter will almost invariably collapse at the inside of the bend, as shown in Fig. 16a. This condition is dealt with by stopping up one end of the tube and blowing out the depression with air from the mouth. It will be found convenient to use a blowing tube as shown in Fig. 16b. The rubber bungs can

be obtained ready bored from any laboratory supplier. Short lengths of glass tube, fire-polished at each end, are pushed through the holes in the bungs. Care must be taken when fitting the tubes; they should not be too tight a fit in the bored holes, and should be lubricated with water or glycerine. When pushing in the tubes, see that there is only a short length (about quarter of an inch) between the hand and the bung. A number of different-sized bungs should be fitted up in this manner so that glass tubing of varying diameters can be dealt with.

Large Diameter Tubing

The technique required for the bending of large diameter glass tubing is different from that needed for tubing of smaller diameter. In this case the blowlamp flame is employed, although passable work can be produced using a batswing burner, in an emergency. A very high degree of skill is also necessary and, since bends in large diameter tubing are rarely required, the method will not be gone into in detail here.

It should be added that, as with all other glassworking, the tubes must be continuously rotated in the flame when heating for bending.

Forming Spirals

When perfection of form is of minor importance, a spiral can be produced by hand-working the tube in a batswing flame.

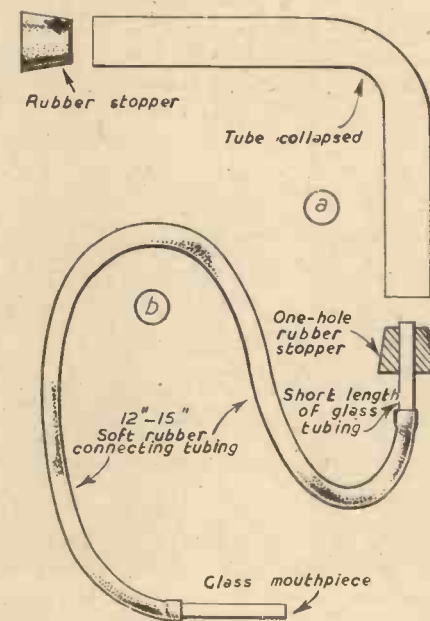

Fig. 16a.—Bend in medium diameter tubing, showing collapse at inside of bend. b. The blow-tube.

Portions of the tube are heated and bent into shape, a further portion being treated in a like manner without pause. It will be found to be more convenient to hold the longer length of tube in the left hand, and form the spiral with the right hand. If care has been taken to make the initial loop truly circular, it can be used as a pattern for the succeeding loops. If a more professional appearance is sought after, the spiral should be wound around a copper cylinder covered with a layer of asbestos paper. It is advantageous if the cylinder can be made to revolve on a fixed vertical axis. The asbestos paper facilitates the removal of the spiral after winding. The copper cylinder should, of course, not possess any rims.

Bulb Blowing

The blowing of a bulb is an operation which has a peculiar fascination, and great

satisfaction is obtained when the result of one's labour is a perfect spherical bulb.

The first operation is to close the end of a piece of tubing as previously described. The open end of the tubing should be fire-polished, as this end will frequently be applied to the mouth during the work. The closed end is now heated in the Bunsen or blowlamp flame, the tube being held at an angle of about 30 deg. from the vertical and being continuously rotated. When the end is soft and red hot, the tube is taken from the flame and the end blown out by gentle puffs of air from the mouth. During the blowing process, either of the following methods can be employed: (a) The tube is held horizontally, and several puffs are given, the tube being rotated in the mouth between each puff. (b) The tube is held vertically, with the closed end down, and several puffs are given, the tube being rotated as before. Method (a) is suitable for most work, but some readers will find method (b) easier to carry out.

If the bulb is not rotated between each puff, the convection currents of air caused by the hot glass will distort the bulb and a truly spherical shape will not be obtained. Since convection currents are not so readily formed in a hot room, it is clear that the hotter the room the better for glass blowing. The room should be at the highest possible temperature, having due regard for the comfort of the operator.

It is well worth while to attempt to blow a bulb or two without rotating the tube, so that the effect can be seen and recognised.

At the end of the initial blowing, the bulb should have the appearance shown in Fig. 17a. No attempt should be made to blow the bulb directly to the size required, for, if this is done, the walls of the bulb will be extremely thin and will possess practically no mechanical strength. The bulb end is again heated and more glass is "gathered" at the end of the tube. It is once more blown out, a little bigger this time, as shown in Fig. 17b. The process is repeated (Figs. 17c and 17d) until a bulb of the desired size, with stout walls, is obtained.

Thermometer Making

The above operation can be employed in the manufacture of various instruments. A typical bulbed instrument is the thermometer. Brief details of the manufacture of this instrument are given below.

A 10-in. length of capillary tube of 1mm. bore is taken and a bulb $\frac{1}{16}$ in. diameter is blown at one end. The thermometer tube is now filled with alcohol (absolute) coloured with a spirit-soluble dye. (A good deep colour is necessary.) The operation of filling is somewhat tricky, but can be accomplished by gently heating the bulb and then placing the open end of the tube in the alcohol. In this way, a quantity of alcohol is sucked into the tube as the bulb

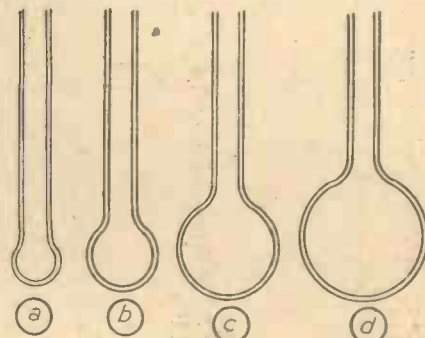

Figs. 17a, b, c and d. Stages in the formation of a bulb.

cools. This alcohol is now boiled in the bulb (immerse bulb in boiling water) so that all the air is driven out of the tube. The end of the tube is again placed under alcohol, when, on cooling, the bulb will be filled. In many cases there will be a small air bubble left in the top of the bulb as shown in Fig. 18a. This is removed by fixing a piece of normal bore tube to the top of the thermometer tube by means of a short length of rubber tubing as shown in the illustration. This tube is filled with the coloured alcohol. The bulb is now heated gently when the alcohol will expand, driving the air bubble before it. On cooling to room temperature, the bulb and stem will be found to be full of alcohol.

The end of the tube is now sealed, and this is carried out in the following manner. The thermometer is clamped with its bulb in a beaker of water at a temperature of 135 deg. Fahrenheit. This causes some of the alcohol in the stem to be expelled. This alcohol is removed with a piece of blotting paper. After a time, the column of alcohol in the stem will begin to contract, as the water in the beaker cools. When there is a free space of about half-an-inch above the alcohol, the end of the tube is sealed by carefully heating with a blowpipe flame as in Fig. 18b. The thermometer tube is now allowed to cool, after which it may be mounted on a board and calibrated against a second thermometer. An instrument such as described has a range of from about 15 deg. F. to 130 deg. F. and will find many uses. A word of warning is necessary here. Alcohol is an inflammable liquid and great care must be taken when filling thermometer tubes. The boiling point of alcohol is well below that of boiling water and all the heating necessary can be carried out by using boiling water and not a naked flame.

Blowing Bulbs in the Middle of Tubes

The technique of blowing bulbs in the middle of a piece of tubing is a difficult one to acquire. Here, skill in the rotation and handling of glass which is soft in the middle, comes into its own. To blow a bulb in this position, a length of tubing is taken and one end is closed (either permanently, or temporarily with a small rubber bung or clipped tubing). The tube is now heated in the Bunsen or blowlamp flame, until it is soft and red hot at the required point. (The ends of the tube must be kept in alignment and must not twist with respect to each other.) The tube is then removed from the flame, keeping the ends in alignment, and a bulb formed by puffing and rotating as carried out for a bulb at the end of a tube. The process is repeated until a spherical bulb of the required size having stout walls is obtained. Failures in this

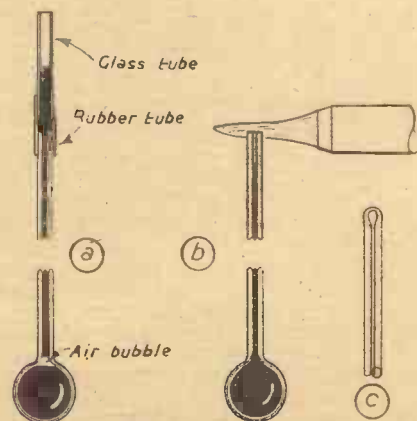

Fig. 18a.—Filling a thermometer tube. b. Sealing the tube. c. Appearance of sealed end.

process are generally due to neglect of the following points. It might be thought that since the bulb is bigger than the tube, it would cause the tube to lengthen, and that the process would be assisted by drawing the ends of the tube apart whilst blowing. This is not so; in fact, the process is best assisted by maintaining a steady pressure on the end of the tube in an attempt to keep it at its original length. (Of course, this latter operation can be overdone, and only actual handling of the glass can give one the "feel" of the pressure to be applied.)

Blowing Bulbs to Destruction

This process is employed when a flanged end is required for joining glass tubing. The advantage of the process over simple rimming (described later) is that the thickness of the glass in the flange is less than the thickness of the main body of the tube. This condition

Fig. 20.—Method of rimming the end of a tube with a brass triangle tool.

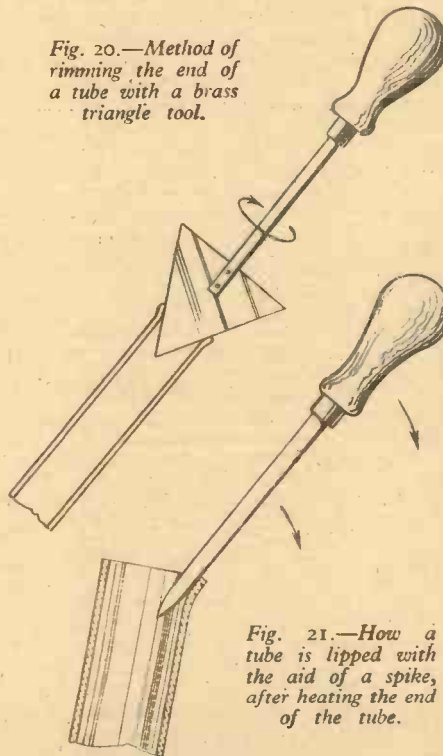

Fig. 21.—How a tube is lipped with the aid of a spike, after heating the end of the tube.

is particularly desirable when joining tubes. The glass tube is first closed at one end and a small preliminary bulb is blown at the end as in Fig. 17b. This bulb is now heated until it is red hot and then a single strong puff is given, when a large thin walled bulb will be formed. This bulb is in general distorted into a curved "sausage" (Fig 19a). Frequently, the bulb bursts during the blowing. The thin glass may be brushed away with a file, leaving a flanged tube, as shown in Fig. 19b. Since this flanging will be required when joining tubes, it is helpful to practise making the flange. Successful flanges can be retained and used later.

Rimming the Ends of Tubes

To rim the ends of tubes the brass triangle is used. The end of the tube to be rimmed is heated until moderately soft; the brass triangle is warmed and coated with paraffin wax, and then inserted in the mouth of the tube and rotated using slight inward pressure. After a little practice an even rim can be produced with ease. (Fig. 20.)

Lipping a Tube

To lip a tube, the end of the tube is heated, first generally, and then strongly over a short arc. The lip is pulled out by placing a

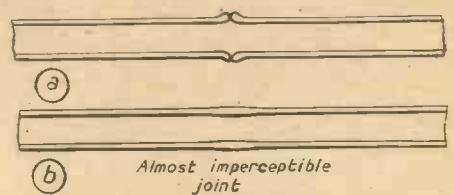

Fig. 22a.—Appearance of joint before working. b. The completed joint.

spike in the tube and bending it outwards as shown in Fig. 21. After both rimming and lipping, the work should be annealed thoroughly.

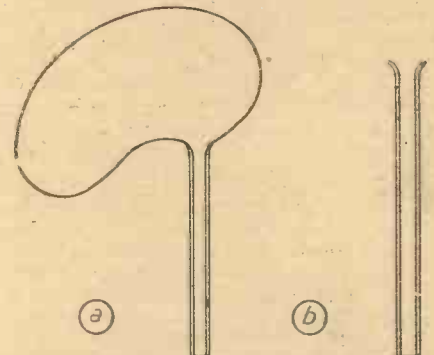

Fig. 19a.—Thin-walled bulb obtained by giving strong puff. b. Flange remaining after removal of bulb.

Joining Tubes

There are many ways in which tubes can be joined. In this article I propose to deal with the three particular techniques, which, in general, are of most use. These involve (a) joining tubes of the same diameter, (b) joining tubes of different diameters, and (c) making T-type joints.

Joining Tubes of Equal Diameters

The tubes are first prepared by flanging them at one end, as previously described. Care should be taken that the flange is not too big, or the joint will be marred by an unsightly mass of glass. The end of one tube is now closed using a small rubber stopper or a piece of rubber tubing fitted with a clip. The open end of the second tube is fitted with a length of soft rubber connecting tube fitted with a mouthpiece (see Fig. 16b). The flanged ends are heated in the brush flame of a blowlamp, and, when the ends are quite soft, they are pushed firmly together and then drawn slightly apart. If this part of the operation has been carried out correctly, an airtight joint of low mechanical strength will have been formed (Fig. 22a). The next process is to improve the mechanical strength of the joint. This is done by working small portions of the joint with a small pointed hot flame. The gas supply to the blowlamp is cut down and the air supply adjusted until a flame of the type shown in Fig. 4d is obtained. A small part of the joint is heated with this flame until the glass softens and caves in. When this happens, a gentle puff of air from the mouth blows the glass out into shape again. In this way, the whole of the joint is covered. In the case of large diameter tubing, it is advisable to heat the whole joint up to softening point occasionally, otherwise rapid local cooling may occur with the production of strains which will cause the tube to break when that part of the joint is worked.

After the joint has been worked over, it is heated up to the softening point and worked to improve the appearance if necessary (e.g., the alignment of the tubes may be checked etc.). Annealing completes the process (Fig. 22b).

(To be concluded)

Making a Lawn Sprinkler

Constructional Details of a Useful Garden Appliance

By L. W. TEW-CRAGG

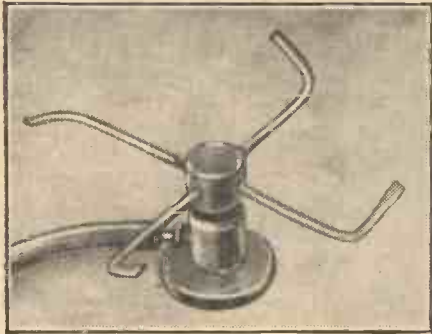

The completed sprinkler.

IT is said that for the culture of lawns, regular watering is a necessity, and to do this in a dry spell of weather with an ordinary watering can is a job not always convenient owing to the amount of time it takes on even the smallest of lawns. If the job is attempted with a hose-pipe the results may be far from satisfactory. So the lawn sprinkler described below was devised. To copy the commercial models is not practical in the home workshop, so a simplified version was designed suitable for anyone to construct who has at his command only the first essentials of engineer's tools. The idea of this type of sprinkler is to eject water from the radial-mounted arms as they rotate, so flinging it into the air, and falling to the ground in a manner likened to a natural shower.

The materials called for here are all brass, excluding the ball race. The main reason being the anti-rust properties of this alloy, and also the ease with which brass may be soldered, so enabling a water-tight joint to be readily accomplished.

The whole sprinkler is designed around the ball race, but as races are rather expensive to buy new these days, probably the reader will not consider the job to warrant the purchase of a new race, when one similar is already at hand. In this case the given dimensions can be modified to suit. But the race used in the prototype is a B.R.L. 5/8 in. single row ball race made by the "British Timken" Company, of Aston Road, Birmingham.

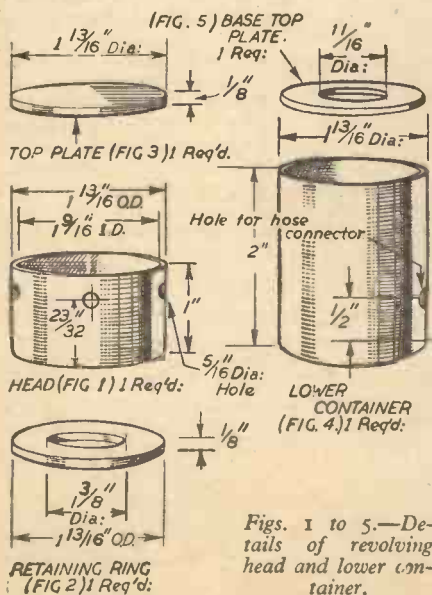

Figs. 1 to 5.—Details of revolving head and lower container.

Construction

The parts shown in Figs. 1 and 4 are both cut from brass tube with a 1 9/16 in. bore, the head (Fig. 1), being 1 in. long, is drilled with four 5/16 in. dia. holes at each quadrant of the circumference to receive the radial arms at assembly. The lower retaining ring (Fig. 2) is next cut to size, the outer circumference being left roughly to shape, and when fitted finally in position it may be filed to the outer cylinder wall. The ball race should fit in this cup with no more force being exerted than the gentle tapping of the race with the shaft of a hammer, as more forceful fitting will only result in damaging the race and making it stiff to turn.

The rubber caulking washer is now cut and placed over the ball race. The fitting of this washer must be such that it does not impede the rotation of the head, yet is close enough to the inner wall to prevent any major leaks of water, when the sprinkler

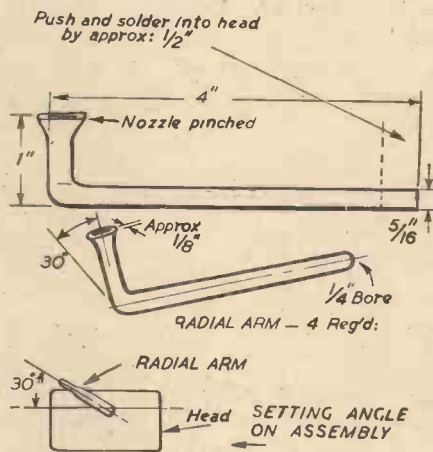

Fig. 6.—Details of radial arms.

is in operation. Small leaks will not be entirely prevented, nor will the efficiency suffer noticeably. Several should be made and stored away in readiness for when the one in use becomes perished. A brass 5/8 in. washer is laid upon the rubber one. Screw on a locknut to the end of the conduit connection pipe, which is approximately 2 in. of threaded 5/8 in. conduit, and insert this through the washers and race in that order, then wind on a second locknut from the opposite end, so clamping the washers and race together. The head should rotate freely if the connection pipe is gripped. Fig. 6 shows the radial arms, four of which are required. These, when formed, are pushed 1/2 in. into the ready drilled holes in the head. It will be noted that they do not touch the washers, having a clearance of about 1/16 in. to ensure this. The top plate, Fig. 3, may now

be soldered into position, so completing the upper portion of the sprinkler. The lower container, Fig. 4, is cut 2 in. long, the purpose of this being to lower the centre of gravity of the sprinkler, so checking the wobble when it is in operation.

The base top plate, shown in Fig. 5, is sweated into position and into the lower container a single hole is drilled of suitable diameter to receive the hose connector which is soldered in. The connection pipe, which has had a locknut screwed on first, is pushed through the hole in the base top plate.

Next place on a rubber sealing washer within the base container, then a brass washer to prevent the locknut from "biting" into the sealing washer, and by screwing home the final locknut the base will be firmly secured to the head. The final operation is to take a syrup tin lid, or one of similar dimensions, and solder it to the base of the

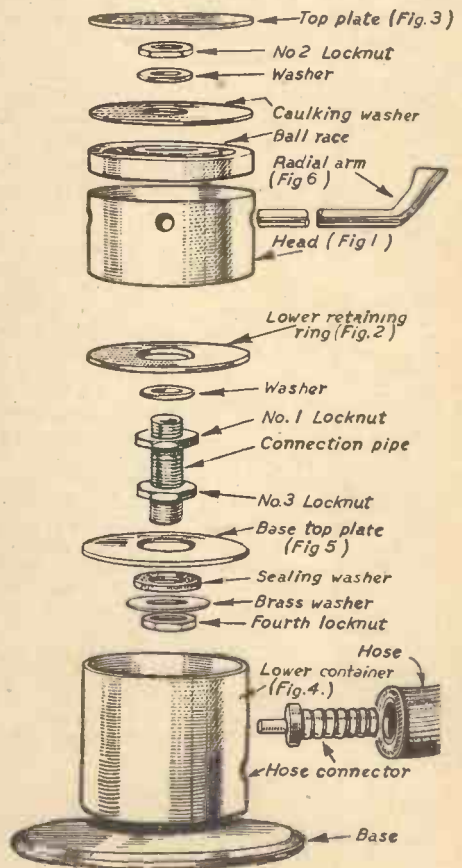

Fig. 7.—Exploded view showing the order of assembly of the various parts.

MATERIALS REQUIRED

- Brass tube, 1 9/16 in. I.D. x 3 1/2 in. long.
- Brass plate 12 sq. in. x 1/8 in. thick.
- Brass tube 5/16 in. O.D. x 22 in. long.
- 1 5/8 in. shaft bore ball race.
- Rubber 6 sq. in. x 1/8 in. thick.
- 2 in. of 5/8 in. threaded electrical conduit.
- 4 locknuts to match.
- 3 brass 5/8 in. washers.
- 1 hose connector.
- 1 syrup tin lid.
- 1 length of garden hose.

lower container. This serves as a steady to the sprinkler, and if extra weight is needed then fill the depression on the under side of the lid with molten lead. The hose is forced on the connector and may be clipped with a Jubilee clip. Place the sprinkler into the centre of the area for watering and fasten the hose to the water supply. As the tap is turned on the sprinkler will rotate flinging water into the air. Fig. 7 is an exploded view that may be useful at assembly.

Dancing Robots

Two Methods of Constructing Figures That Will Move in Time to Dance Music Issuing From a Loud-speaker

THE first figure, which will dance and pirouette in time to dance music issuing from the loud-speaker, can be made easily from parts which are almost certain to be found in any "junk" box.

An application of the principle of the electro-magnet is used, operated by a relay, which is fed from the output of any wireless set, in conjunction with the loud-speaker.

The parts required are: one telephone ear-piece without cap and diaphragm; old electric bell; one fixed condenser of 1 or 2 mfd. capacity; one fixed condenser of .05 mfd. capacity; one cigar box 8in. by 5in.; 4 terminals; Leclanché cell or some form of battery to deliver three or four volts.

Detailed measurements are not given, as these will vary in each case, depending on the size of the telephone ear-piece and make of electric bell.

With the aid of a fretsaw remove a part of the bottom of the cigar box, as shown in Fig. 1. The electric bell is dismantled and one of the coils forming the electro-magnet dispensed with, leaving the other coil fixed to the support, which is screwed inside the box above the aperture. Where the holes of these screws are bored slots should be cut, so that the position of the coil may be raised or lowered. The construction of the relay calls for some care, as the mechanism is essentially very delicate.

The Base of the Electric Bell

This is used to accommodate the relay, and the telephone ear-piece is screwed down to this firmly in the centre. Next, take the armature of the bell and cut off the clapper portion, which is of no use. The armature is then mounted on the base by means of a piece of brass or strong tin, bent into such a position that the armature just clears the top of the ear-piece. The armature, of course, must be parallel with the magnets of the ear-piece.

The remaining piece of the bell, the long strip of metal which held the contact screw or "make and break," is now bent into position, and screwed down to the base at the opposite end of the armature mounting. It is very important to have this part fitting correctly, as the success of the gadget depends on the adjustment which can later be made by the contact screw. The contact screw should occupy its original position and touch the silver contact of the spring riveted to the armature. If you have gauged everything correctly the result should be as shown in Fig. 2.

The terminals are now mounted two at each end of the base. Connections are taken from the ear-piece to one pair of terminals, marked "radio." The other pair should be marked "low tension."

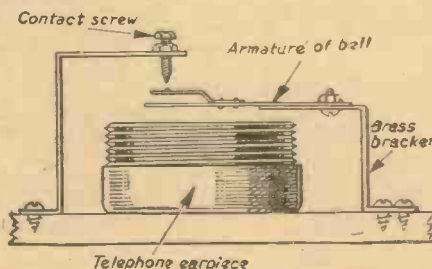

Fig. 2.—The relay.

The Relay

The completed relay should now be screwed to the inside of the cigar box lid. The fixed condensers are placed in the corners of the box and connections made as follows.



Fig. 3.—Details of the figure, showing joints in port for support for arms and leg.

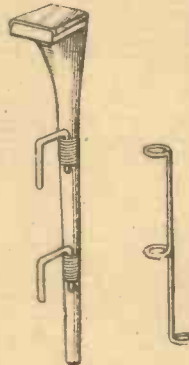

Fig. 4.—The support for the figure. Fig. 5.—The wire pillar.

One end of magnet coil to large capacity fixed condenser and contact screw; other side of condenser to terminal "low tension." From this terminal to .05 mfd. fixed condenser and other end of magnet coil. Other side of .05 mfd. condenser to armature mounting and second "low tension" terminal. (See Fig. 1.)

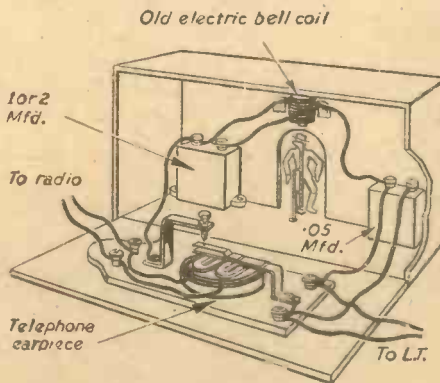

Fig. 1.—The general arrangement of the device.

The Figure

The construction of the little jointed figure presents no difficulties (see Fig. 3). The essential point to bear in mind is that the completed figure must be very light in weight. The height of it should be a half-inch less than the aperture cut in the box. The figure itself is cut from thin cardboard and jointed at both arms and one leg by ordinary pins. Cut off a piece of pin, push through the joint and put a blob of solder on the end without a head. Take a piece of wood the same height as the figure and whittle it into the shape of a match-stick, leaving it just thick enough at one end to take a small piece of tin, which is bent over and notched into the sides. This will be the top. With some thin wire fix two arms to the back of the jointed figure with glue.

The end with the small piece of tin will be behind the head, and the other end will pass behind the unjointed leg.

Finally, a support is made to take the wire arms, which now project from behind the figure, and will serve to hold it upright, but free to move upwards. This support is easily made from wire, and consists of two loops to take the wire arms and another loop at the bottom to take a screw for fixing to the box (see Fig. 5). The proper position of this support is important. When the wire arms of the figure are in the loops the small piece of tin forming the head of the figure must be exactly underneath the electro-magnet.

Wiring Up

The terminals marked "radio" are wired up in parallel with the loud-speaker and the battery wired to terminals "low tension," as in the circuit diagram Fig. 6. If a mains unit is used with a fairly large transformer for low tension, connections may be taken from this instead of a battery or cell.

Tune in the local station to dance music, and make adjustments to the contact screw and the screws in the slots holding the electro-magnet, until the best working positions are discovered, after which no further adjustment should be necessary.

In the experimental stages the spark set up by the make and break contact was picked up by the valves and sounded in the loud-speaker like a machine gun. However, the use of the fixed condensers successfully overcame the difficulty. When in operation this little robot is positively uncanny, for when the circuit is closed and opened alternately by the relay the figure will jump up and down each time in exact time to the beat of the dance music.

A More Simple Design

This design utilises a hand-operated tapping board to "make and break" the circuit, and as this can be concealed in the pocket there is nothing to show how the figure works.

The base, side pieces and platform are cut from ¼in. fretwood to the sizes shown in Figs. 7 and 8. The front and back are cut from cardboard and painted or otherwise decorated. Failing any artistic ability in this line, a suitable picture postcard could be glued to the back to form a background.

In the centre of the platform bore a hole about 1½in. diameter, then cover the platform with a piece of paper, pasted on. Damp this before pasting, then it will dry quite taut. Before fixing the platform in position arrange the electro-magnet in place, also the connections.

The Electro-magnet

The electro-magnet core should be of soft iron, ½in. dia. and 1½in. long. The bobbin

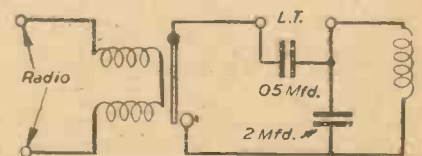
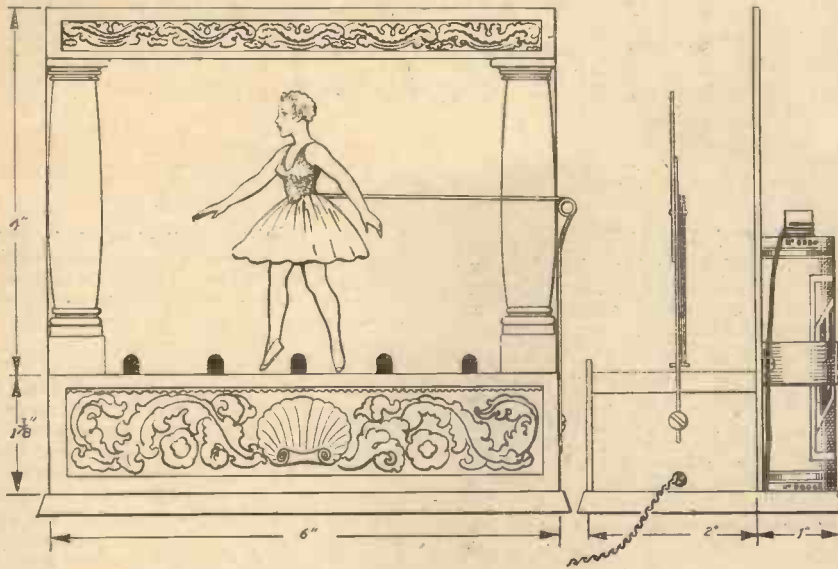

Fig. 6.—Circuit diagram.



Figs. 7 and 8.—Front and side views of the finished model.

1 1/4 in. long and 7/8 in. dia., wound full with No. 30 D.S.C. copper wire.

A hole is bored in the base for the core to fit in tightly: this will hold it securely enough, and if the base is 1/4 in. thick the iron core will just come beneath the paper covering of the platform.

The plan view, Fig. 9, shows the paper partly torn away and reveals the magnet beneath, also the connections.

Bore a small hole in the right-hand side piece to allow entry of a length of flexible wire. Near the magnet fix two small screws, twist the end of one piece of flex and one end of the coil winding together and secure under one of the screws. To the other piece of flex twist the bared end of a short length of wire and secure both under the second screw. The remaining end of the coil winding is joined in a similar manner to a length of wire and fixed under a third screw. Fig. 9 shows these connections: the two loose ends of wire are connected to the terminals of a pair of batteries, placed behind the background, and the flex is connected to the tapping board.

Before completing these final connections the platform should be nailed to the side pieces, and the cardboard front and background glued in place.

wires fastened to the batteries and also a wire connecting the remaining terminals, so that the batteries are connected in "series." The doll will work with one battery, but the added strength of the second battery will give more movement and greater agility to the figure.

The Figure

This is cut from tinfoil. Copy Fig. 10 over 1/2 in. squares on to a piece of paper, paste on to the tinfoil, and cut carefully with an old pair of scissors. The small tabs on the base of the feet are bent at right angles, one to the rear and one to the front, so that they will not catch each other.

Punching the Holes

After punching the holes file off any burrs. The legs are loosely pivoted on pins in the manner shown in Fig. 11 a plan view. It will be noticed that a thin washer separates one leg from the body and a small bead the other, so that they can move freely and not catch each other. Thread each leg and bead, or washer, on a pin, push the pin through the body and hold it there firmly while it is soldered, then snip off the remainder of the pin as close as possible.

The doll is supported by a bent piece of springy steel or brass wire, soldered to its back, the wire being fixed at its other end under the head of a screw as shown. It should support the doll directly over the magnet core and should be adjusted for the best results. The doll should then be enamelled in bright colours and finished as realistically as possible.

The top spring on the tapping board should be pressed by the finger in time to the music and the doll will dance accordingly.

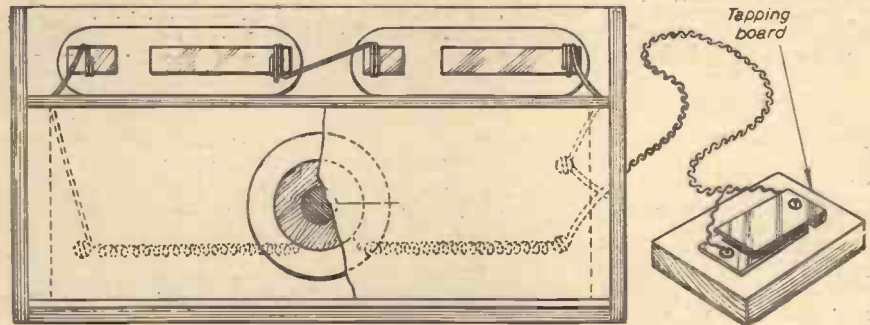

Fig. 9.—A cut-away plan, showing batteries and connections.

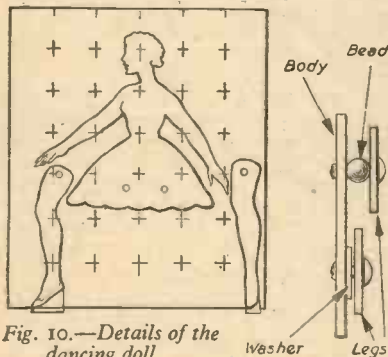

Fig. 10.—Details of the dancing doll.

Fig. 11.—How the legs of the doll are fixed.

The Batteries

These are held in place by means of an elastic band or a thin metal strip. The tapping board is merely a small piece of fretwood to which is screwed two pieces of springy brass, separated from each other by about 1/4 in. Fig. 9 shows the loose

A Precision Measuring Machine

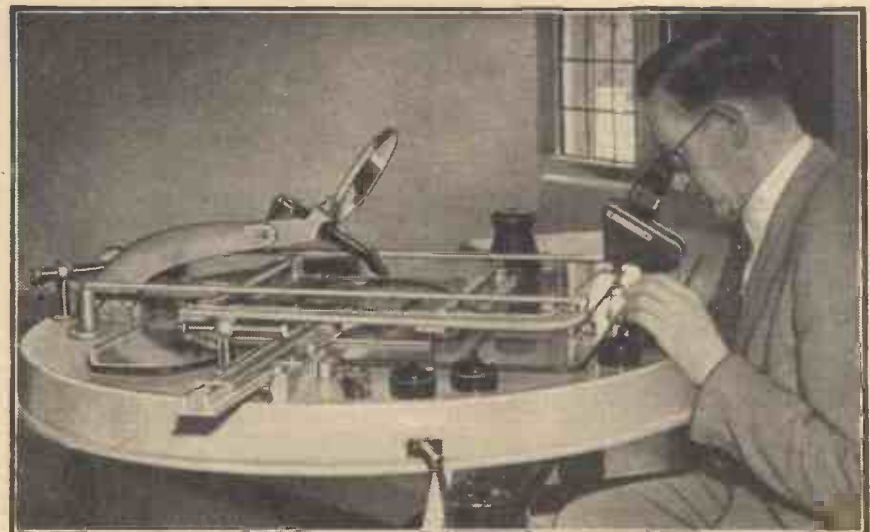

This Zeiss measuring machine, installed in Hurstmonceaux Castle, Sussex, the new quarters of the Royal Observatory, is stated to be accurate to 1/10,000 of a millimetre. It is used to measure photographic plates of stars.

The Hydrofin

A Brief Account of an Unorthodox Craft With Several Novel Features

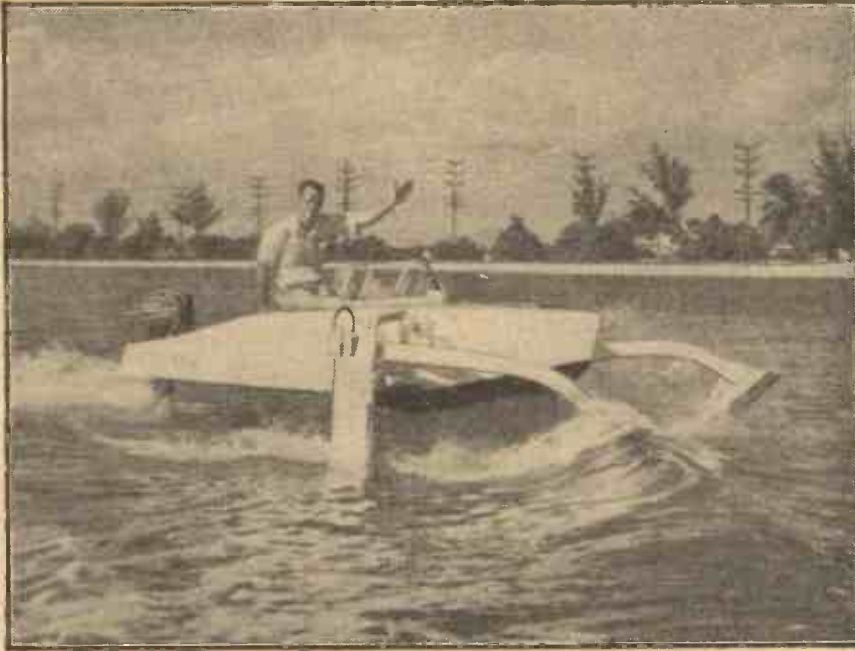

A Hydrofin at speed.

THE Hydrofin, the craft which it is thought may revolutionise marine travel as we know it, has been chiefly developed by Christopher Hook, a British engineer, and is now being investigated and developed by the U.S. Navy. These foil boats, or hydrofoils as they are called, when travelling at speed, resemble a boat on legs. Each of the craft's three legs (hydropeds) has at its foot a hydrofoil which travels under the water and raises the hull clear of the surface. On two arms projecting forward are mounted jockeys which predict the state of the water surface in front of the craft. Small waves and choppy seas are not felt by the Hydrofin's passengers at all as the hull rides above them and in rough water the effect is that of a well-sprung car. The power is supplied by an outboard motor.

Hydrofoil boats first interested the inventor when he was a civilian prisoner of Vichy France during the war, and in the use of these large craft with their hulls clear of the water he thought lay the solution to the U-boat problem. Realising that this system could only be used in conjunction with light hulls he studied flying-boat design and after several years work produced the first Hook Hydrofin at Cowes. French naval experts were impressed when he demonstrated his invention to them, but the authorities, when he returned to England, showed no interest. Hydrofoil boats, constructed and used by Germany during the war, were only successful in calm water and the authorities did not consider that any improvement would render them more successful in rough water. Finally, they reversed their decision, but were too late, the inventor had arranged to go to New York. In America he demonstrated his craft to the U.S. Navy, who showed considerable interest, and now Hydrofins are being built under agreement with the Miami Shipbuilding Corporation, who plan to export the craft

to all parts of North America and the West Indies.

Action of the Hydrofoil

The hydrofoils are mounted at the foot of each of the three hydropeds and it is these that cause the hull of the craft to rise out of the water. They work on the same principle as the aeroplane wing and do the same job—that of providing lift. Water is 815 times denser than air, so the hydrofoil can be made much smaller in proportion to the size of the craft. The hydrofoil exerts

seen that all angular movements of the jockey arm will be transmitted in incidence changes to the hydrofoil, giving different degrees of lift to the craft according to the size of wave ahead.

Hydrofin Advantages

The Hydrofin has advantages over both aircraft and planing craft in some respects. It has no hull in the water and is not subject to surface effects: hence it does not have to reduce speed in rough water. Hydrofoils are claimed to be over 50 per cent. more efficient than planing hulls and are thus faster for equal power. They fly over wave tops with no pounding. With incidence control the recovery moments are powerful ones so that there is no oscillatory roll; seasickness is almost impossible, which is an important military aspect. They can be built in large sizes (at present up to 60ft. and able to carry a payload of 15 tons).

There are advantages, too, when the question of cost is considered. Compared with surface vessels or planing craft, operating costs are less and capital costs are only one-eighth those of helicopters for equal payload capacity. Maintenance costs are increased 5 per cent. over planing craft, but payload ability exceeds aircraft, rotorcraft and even planing hulls.

Suggested Uses

A big advantage in the naval field is the extra stable gun platform, and there is a possibility of Hydrofins being used for patrol, escort, torpedo carrier or retriever, invasion, submarine killer duties, and many others.

They could be employed as inter-island transport and feeder lines for air services at very low capital cost, or for cross-channel service. Among the many other suggested uses are included those of air-sea rescue or lifeboat, customs patrol, fishery, coastguard and pilot boats, exploration, tourist trade and yachting.

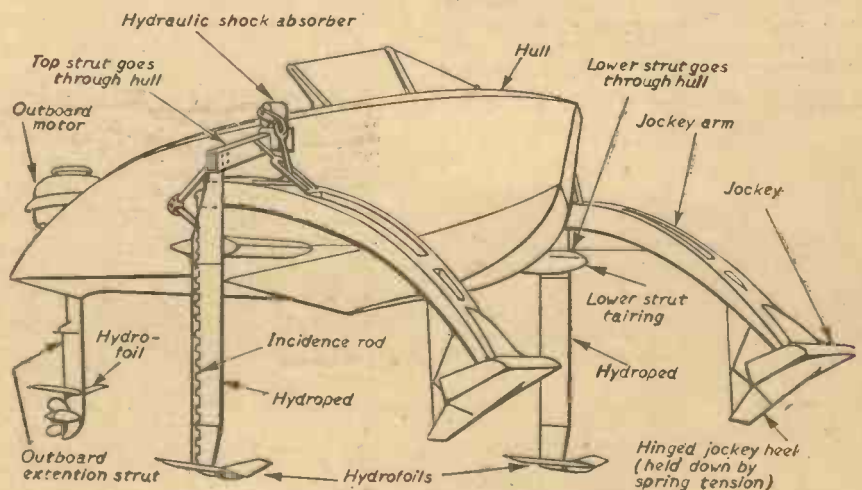
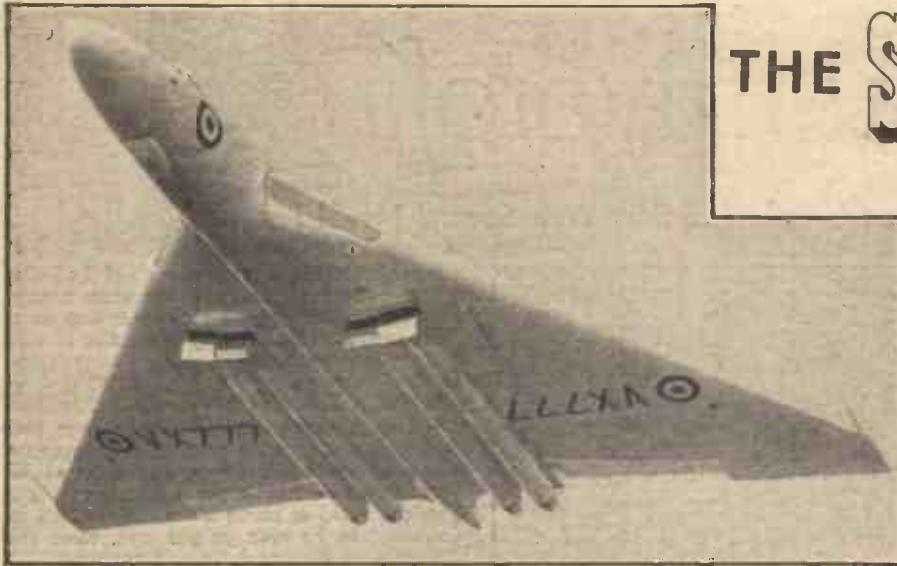

Diagram showing the component parts of a hydrofin.

lift at far lower speeds and needs far less power to bring it into operation.

The jockey arms, which project to the front of the craft are pivoted and the rear end behind the pivot is joined by an incidence rod to the heel of the hydroped. It will be

Standard production Hydrofin models are 12½, 18½ and 24½ft. long, carrying 2, 5 and 10 people, and the manufacturers in America prophesy that these crafts will become the major means of short distance water transportation.



The A. V. Roe "Vulcan" bomber, powered by four Bristol Olympus jet engines.

SO all this has happened since I was two months and ten days old! That was my first thought while approaching the Farnborough Show. True, a great many other things have happened since that original forced landing of mine on this planet, but nothing strikes the imagination to compare with what has developed from a 248 yards heavier-than-air flight on a cold, misty morning at Kitty Hawk on December 17th, 1903.

Having missed last year's show, I had the advantage of the experts. They were all saying that, as far as new types both military and civil are concerned, the 1952 show was unique. Even the British aircraft industry can hardly be expected to produce a whole flock of completely new military and civil aircraft every year. Last year's show saw several new fighters for day and night use and several distinct types of jet bombers. There were several gas-turbine airliners of new design and the "Princess," our largest aircraft, appeared for the first time in 1952. So there was a delayed treat in store for me.

There is always some small satisfaction in being in the right place at the right time and I shall always be grateful to Messrs. Hawkers for inviting me to view the show from their most comfortable and admirably-placed enclosure. Suspicion that your reporter was in the right place was confirmed each afternoon as Neville Duke provided his

so-easy-looking thrills in Sir Sydney Camm's Hawker Avon "Hunter" F.I. None could ever forget that graceful red streak and the subsequent roar, that seems infuriated at having been left so far behind, chasing madly and hopelessly after its creator.



Neville Duke taking off in his swept-wing Hawker "Hunter" jet fighter, during his first attempt on the air speed record recently.

(To friends who asked later how fast Duke looked to spectators, I said: "If you looked down to read one line of newspaper type when Duke first appeared he would be disappearing by the time you could look up again!")

Let us now run through the flying display. The show opened with the Westland Aircraft "Wyvern." This prop-jet torpedo fighter is

being delivered to the Fleet Air Arm, as are also the "Attacker" and "Sea Hawk" jet fighters. The "Wyvern" is a deck-landing aircraft. It carries a torpedo, 16 rocket projectiles and four 20m.m. guns. The "Sea Hawk," which showed its paces a little later, is powered by a Rolls Royce Nene engine. It carries four 20m.m. guns and is being produced by Sir W. G. Armstrong Whitworth Aircraft Ltd., as the parent company is concentrating on the "Hunter."

First Thrill

My first major thrill of the first afternoon

THE S. B. A. C. F.

SH

A Brief Account of the Flying

By THE MARQUIS



A general view of some of the aircraft which were seen at the Farnborough display. In the foreground are the "D.H.110" and the "Javelin."

FARNBOROUGH

SHOW

Display and Indoor Exhibition

OF DONEGALL

The Vickers-Armstrong "Viscount" B.E.A. airliner with four Rolls Royce Dart engines not being forthcoming; we turned to look for the Percival "Pembroke." Developed from their "Prince," this is an R.A.F. supply and occasional ambulance aircraft. It is powered by two Alvis Leonides 550 h.p. engines.

Next the 14-17-seater de Havilland "Heron" airliner. There is a demand from points as far apart as Norway and New Zealand for this handy little liner, which was developed from the D.H. "Dove." I well remember doing a tour of Britain's fly-



The Short Brothers and Harland, Ltd., "Sea Mew" aircraft seen prior to take-off at Farnborough.

the "171" popping down at Waterloo or elsewhere on its shuttle service from London airports. The last of the helicopters to show its paces was the "Bristol 173." This is a big chap designed for 13 passengers with two Leonides engines. Ignoring the rotors, which are not rendered ineffective by switch-

beauty of line, I think that the "Canberra" is my present favourite.

The "Meteors"

Two more "Canberras," one with Bristol Olympus engines and the other with Rolls Royce Avons, made similarly spectacular take-offs after the Gloster Aircraft "Meteor 7" flown by Brian Smith. The "Meteor" is, of course, an old friend, in its various versions having been in R.A.F. Service for nearly 10 years. The "Meteor" that was demonstrated was a trainer, but other "Meteors" perform as night fighters, reconnaissance machines equipped with photographic facilities, interceptors and fighter reconnaissance. The "Meteor 7" is, of course, an "Old Faithful" to the Duke of Edinburgh and to most other pilots who have won their wings in the last years.

Yet another subdivision of the flying display starts with the Percival "Provost," which is also an R.A.F. trainer, and this was followed by the "Aiglet Trainer" by Auster Aircraft, an ideal light aircraft for those lucky enough to be post-war private owners. It floats along at some 110 m.p.h. on its Gipsy Major engine, takes off in well under 200 yards even in very slight wind and stalls just under 40 m.p.h. Its sister machine, which has a negligibly higher speed, is powered by a "Cirrus Major 2" of 140 h.p. as opposed to the 130 h.p. of the "Aiglet's" Gipsy Major 1.

Once again we meet the deservedly popular



The Gloster "Javelin" two-seater all-weather and night fighter, powered by two Armstrong Siddeley jet engines.

ing clubs in one of the first "Doves," and it is to be presumed that the "Heron," which has four Gipsy Queen engines of 250 h.p. each, gives even more luxurious travel. Her speed is about 165 m.p.h.—a beautiful-looking aircraft.

Helicopters

The second section started with a demonstration of landing a helicopter with engine switched off. This until recently hazardous operation was performed by the Westland Aircraft Ltd. "S.5.1." In this machine the Alvis Leonides has superseded the Pratt and Whitney Wasp Junior. If you remember your pictures of the sinking ship *Flying Enterprise* you will remember the rescue efforts of this Sikorsky, which family of helicopters saved many thousands of lives in the Korean war.

By this time I was prepared for almost anything except for looking up to see the Saunders-Roe "Skeeter" passing the Hawker enclosure backwards. Of course, one supposes, the only British midget helicopter and smallest aircraft in the whole show felt it had to do something unusual to call attention to itself. Both Army and Navy are using slight variations of the "Skeeter."

Next the "Bristol 171"—another small helicopter, but a giant compared with our back-peddalling friend of a few moments ago. The "171" has the distinction of being the British pioneer of Airline Ferry duty. Doubtless Londoners will get used to seeing

ing off one of the engines, we have here a helicopter with a conventional airliner shape.

Then there was a very loud noise which seemed excessive for the "Sea Hawk." But it was the "Canberra" Ferrying Coach determined to have a look in spite of what the programme said. Its climb can only be described as breath-taking for so large a machine, and you will recall that a "Canberra" captured the all-time height record of 63,668 feet last May. For grace and



The Saunders-Roe "Princess" flying-boat, which is powered by 10 Bristol Proteus turbo-prop engines.

550 h.p. Leonides engine as the Scottish Aviation "Pioneer" 14-16-seater transport takes off. This is a high-wing machine with the engines in the wing and a stalling speed of under 50 m.p.h. Its take-off was very good indeed and it cruises just on 175 m.p.h.

Turning to the back of the programme, we have—or we thought we were going to have—the privilege of admiring the D.H. "Comet 2." However, like the Beaver in Lewis Carroll's *Hunting of the Snark*, the "Comet

There were several other most interesting aircraft before the show ended including Duke's colleague Bedford in the "Hunter F.2," with "Sapphire" engine, as opposed to Duke's "Avon" in the record-breaking prototype.

But I somehow omitted the "P.IIIA" Boulton Paul demonstrated by Gunn. What struck me most about this delta-wing, very fast research machine was that it is comparatively noiseless. The only difference I could

be threatened with summary extermination in the break-up yards—or wherever they carry out such iconoclastic excesses.

The Indoor Exhibition

All the experts seem to be agreed that what is called the static, or indoor, exhibition was of more news-value than the flying display. As I explained at the beginning, few of the aircraft in the flying display had not been seen by them at last year's show. Ever-dutiful, your reporter did manage to tear himself away towards the end of the flying, and the keynote of the static show was provided by the number of new materials that should speed-up manufacture both of aircraft and the modern offensive weapons that they carry. Most of these new materials have long, quite unrememberable names. There was one called asbestos phenolic, for tanks, and there were many plastic materials for mouldings.

In spite of the insistence of the experts on the great importance of the aforesaid new materials—and I would be the last to dispute it—the models of aircraft shortly to come were well worth scrutiny.

Beside Handley Page, Percival and other projects new helicopters were shown in model form including an enormous Saunders-Roe for B.E.A. There was, regrettably, no model of the Percival 8-seat helicopter. I was told that the Ministry of Supply who ordered it had a last-minute re-think and the model was suppressed.

To me, having missed the 1952 show, this year's S.B.A.C., Farnborough, was a great experience whether flying or static. And the weather was well-behaved except for a low ceiling on a couple of days. Right through there was an unmistakable conviction that everybody was having a good time... even the unending supply of couldn't-care-less visitors who volunteered to allow themselves to be catapulted from a facsimile pilot's ejector-seat for the amusement or hopeful morbidity of a large crowd. It seemed happy to have paid its money just to gape at this interesting, but admittedly minor, contribution to the S.B.A.C. Show, as an æsthetic experience.



A Bristol type 173 Mark 2, 10-13 seater helicopter, powered by two Alvis Leonides piston engines.

2." appeared unaccountably shy—and refused to show itself to us.

The "Gloster Javelin"

But the "Gloster Javelin" soon held our attention, being, as you ought to know if you have been paying proper attention, the first delta-wing fighter (night) to take off and its official designation of "F.A.W.1" stands for "Fighter All Weather." The "Javelin's" power is provided by two turbo-jet Armstrong Siddeley "Sapphires." Having no idea what its armament is, I am relieved when a Hawker expert volunteers the information that this is hush-hush, anyway. But it was certainly no secret from anybody that the "Javelin" is capable of aerobatics at very high speed that are a joy to watch. Although a delta-wing machine, it has kept a very ordinary looking tail unit as though it had refused to be parted from an old crony.

The "Short S.B.5," which later made a peach of a landing, is a very queer-looking customer. Its wings are swept right back and it has a triangle of a wing stuck horizontally on to its tail. It is destined for research. To this end it is possible, in a very short time, to adjust the sweep of the wings in various combinations with high or low tail.

We were next treated to the Handley Page "Victor" with its crescent wing, flown by Squadron Leader Hazelden. I think I am right in saying that it first took the air on Christmas Eve, 1952. As it is our latest jet-bomber nothing is printable about its performance as it hurtles along impelled by its four "Sapphire" turbo-jets. There are nose-flaps on the leading edges to facilitate take-off, landing, and to give slower flight. The tail end houses the air brakes and there is a curious excrescence under the fuselage which, for all one knows, might contain anything from radar equipment to something at present a hundred per cent. taboo.

The Hawker "Hunter"

It was at this point in the programme that Neville Duke did his "that-is, that-was" roar-past, in a blaze of scarlet glory... at last, the "Hunter F.1."

see from the "P.III" which took the air late in 1950 was that the aircraft Gunn was flying had acquired air-brakes. The engine is a Rolls Royce "Nene," and this aircraft is provided with a braking-parachute which appeared to work usefully.

There we must leave—and we are very near the end—the flying display except to remark on the majestic loveliness of the Saunders-Roe, 150-ton, 380 m.p.h. "Princess" flying-boat. She can take 200 troops, has a range of 3,500 miles, carries 14,500 gallons of kerosine; and it seems a crime that a floating vision such as she is should

New Fire Resisting Cables

A NEW range of asbestos paper tape insulated cables has been developed by Pirelli-General Cable Works Ltd. These cables are suitable for use in circuits up to 660 volts in situations where fire resistance, non-inflammability, maintenance of electrical properties under elevated temperatures, and non-ageing properties are required. They are patented under British Patent No. 661540.

Construction

Copper conductors, which may be single or stranded, are lapped with a special quality asbestos paper tape. The cores are laid up, asbestos paper taped, and sheathed with a welded aluminium sheath (Asbestal) or, alternatively, with a welded stainless steel sheath (Asbesteel). The smaller Asbestal cables have a cold-welded aluminium sheath with a small longitudinal fin, while the larger Asbestal cables have a corrugated argon-arc welded aluminium sheath, which has the advantage of flexibility similar to that of a lead-sheathed cable, combined with sufficient stiffness in relation to weight to enable the distance between supports to be considerably greater than that necessary with lead-sheathed cable. The corrugations also increase the resistance of the sheath to mechanical damage.

The multicore cables are designed to have a constant insulation thickness between con-

ductors, with a variable thickness between conductors and sheath. The conductor insulation thickness varies very little from 0.05in. but, owing to the limited number of sheath diameters, considerably more than 0.05in. thickness between conductors and sheath is used in many cases. Single core cables have all to be insulated to fit the nearest standard sheath and considerable variation above a 0.05in. minimum consequently occurs. The asbestos-paper tape employed has a high degree of resistance to moisture absorption and to destruction by fire.

The insulant is indestructible and the cable itself will continue to function at temperatures up to the melting point of the sheath. Since the insulant is dry, the cables are non-bleeding, rendering them eminently suitable for vertical runs which may be subject to overload or high temperatures.

The corrosion resistance of Asbestal is similar to that of other types of aluminium-sheathed cable and is in general not very different from that of lead-covered cable. Where the cable is to be drawn through ducts, laid direct in the ground, or installed in corrosive atmospheres, suitable additional protective covering is recommended; the type normally supplied being compounded, P.V.C. double taped, lapped with two compounded glass staple tissue tapes, and compounded hessian taped overall.

Flash Photography

Simple Battery, Capacitor and Electronic Flash Apparatus

AMATEUR photographers are making increased-use of flash photography, and the majority of present-day cameras are fitted with synchronising contacts for this purpose—these are, indeed, found on many of the cheaper box cameras, in addition to more expensive equipment. The use of a flash bulb for illumination renders the photographer independent of lighting conditions, and snapshots indoors are possible with even the cheapest camera. It is by no means essential that the camera have synchronising contacts, as the "open flash" method is possible with any camera. In addition, excellent results can be obtained with even the simplest possible equipment and at extremely low initial cost, as will become apparent.

Flash bulbs of various sizes may be obtained from all photographic dealers. The small bulbs are least expensive and suitable for use indoors, with small groups, etc. The larger bulbs have a more powerful light output and are used for large groups, etc. There is also on the market a type of flash button which contains flash-powder in a capsule, ignited electrically. These are a great deal cheaper than the glass type of flash bulb, but emit a naked flame and some smoke. The glass type of bulb, usually filled with magnesium wire, is smokeless and the flame is contained within the bulb itself.

Flash bulb manufacturers list the light output of their bulbs to guide the photographer in making a correct exposure. For ordinary purposes, even a small lens aperture is ample, with the result that the possessor of an ordinary box or folding camera can use such bulbs. The flash is of exceedingly short duration, so that moving objects are rendered sharply, and there is no need for the subject to be posed or still.

Battery Firing

The simplest circuit, and one largely used, is shown in Fig. 1, where the bulb is fired directly from a battery. A dry battery of 3, 4½ or 6 volts is suitable, but it must be in reasonably good condition or a delay may arise before the bulb fires, if it fires at all. Very small torch cells are not very suitable, but the dry batteries used in torches of medium and large size are satisfactory. The voltage is not important, but reliable firing of the bulbs is assured by using a fairly high voltage, obtained from a fairly large battery in good condition.

A metal reflector is used to direct the light towards the subject, and the battery may be contained in an attached case or housed separately, with flexible connections. The length of leads should be kept down and fairly stout flex should be used. If long

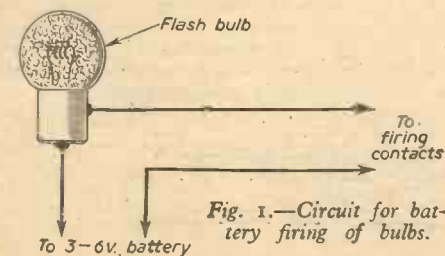

Fig. 1.—Circuit for battery firing of bulbs.

By F. G. RAYER

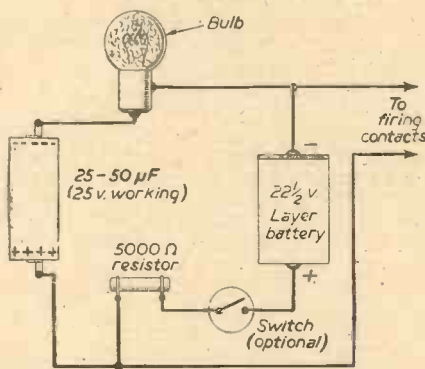

Fig. 2.—Circuit for capacitor firing.

leads are required for any reason a battery of at least six volts should be used.

Screw-in bulbs may be fired by inserting them in a flashlamp, this being suitable for the "open flash" method. Here, the camera shutter is opened, the bulb fired, and the shutter then closed. This can be done with cameras having no synchronising sockets, but general lighting should be subdued so that no impression is made on the film while the shutter is open.

In synchronised cameras contacts in the shutter close when the shutter is reaching its fully open position, thus firing the bulb. The shutter is usually set at 1/25th second for this purpose, though high-class cameras may be synchronised at higher speeds. With flash bulbs a slight delay arises between the making of contact and firing, and this is allowed for more readily when a fairly slow shutter speed (e.g., 1/25th second) is used. With extremely brief exposures the flash

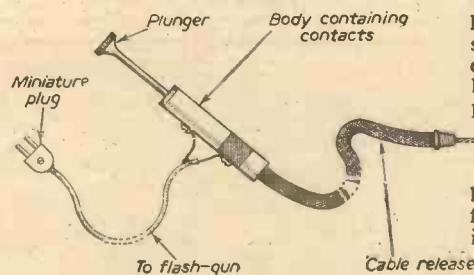

Fig. 3.—Contactor cable release for unsynchronised cameras.

may not coincide with the opening of the shutter, so that blank shots result.

Capacity Firing

The circuit for this method is shown in Fig. 2, and it has several advantages when bulbs are frequently used. Power is supplied from a small "deaf aid" type battery and charges up the condenser. This charging current flows through the bulb, but is not sufficient to fire it because of the 5,000 ohm resistance. When the firing contacts are closed the condenser discharges abruptly through the bulb, firing it.

As the operating voltage is so much higher the bulbs are fired unfailingly, even with long leads. Regular firing is also

obtained when the battery is in poor condition, since it is only called upon to deliver a low current to charge the condenser. (With direct firing, as in Fig. 1, a current of 1 amp or more is required.) This type of gun is accordingly coming into increasing use. The condenser is of ordinary electrolytic type, readily obtainable from radio stores. The value of the resistor is in no way critical.

If the optional switch is omitted, the flash bulb should only be inserted shortly before the shot is to be taken, or the battery will slowly discharge through the condenser. Correct polarity of battery and condenser connections must be observed.

The required components can be accommodated in a small case, and the gun may be used for open flash or synchronised flash.

Synchronised Release and Mounting

The manner in which a synchronised shutter works has been described, and accessories are available which will enable unsynchronised cameras to be used in a similar way. One is shown in Fig. 3, and consists of a cable release with contacts. The release is screwed into the release socket of the camera and the leads connected to the flash-gun. When the plunger is depressed the camera shutter is opened and contact simultaneously made in the release barrel so that the bulb fires. Arrangements of this kind can be made up without much difficulty.

It is usually more convenient to have the flash-gun and camera fitted together in one unit, and a simple way of arranging this is to use a bracket, as shown in Fig. 4. The gun assembly can then be secured to the camera by means of a suitable camera-screw inserted in the threaded tripod hole found on almost all cameras.

An alternative is to hold the camera in one hand and flash-gun in the other, and this is sometimes helpful as it gives a side lighting effect. Or camera alone, or gun alone, may be rested on a convenient object, or supported on a tripod.

Electronic Flash

Those methods so far described use flash bulbs or buttons, and these provide a single flash only. When many shots are taken, it is more economical to use an electronic tube,

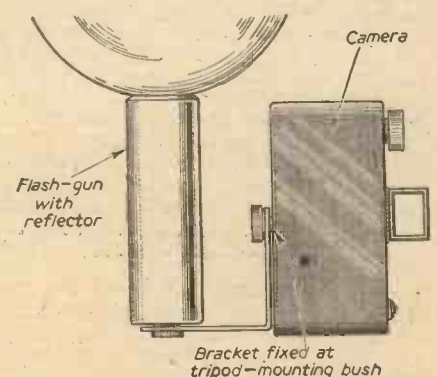

Fig. 4.—Flash-gun and camera mounting.

which can provide several thousand flashes. These tubes require a much higher operating voltage than flash bulbs, but the smaller tubes can be worked satisfactorily from dry batteries such as used in deaf aids, or for H.T. purposes in radio receivers.

An electronic flash circuit is shown in Fig. 5, the supply being derived from dry batteries, accumulator and vibrator, or mains unit.

When the switch is closed, the condenser C1 charges up through the 3,000 ohm resistor.

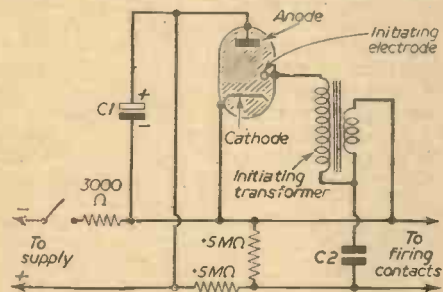

Fig. 5.—Circuit for electronic flash.

tor. The condenser C2 also charges, but to a lower voltage since it draws current from a potential divider (the two .5 megohm resistors). When the firing contacts are closed, C2 discharges abruptly through the primary of the transformer, which has a high step-up ratio. The resultant surge is applied to the tube electrode as shown, initiating the flash between cathode and anode, which is provided by the charge in C1.

Suitable components for this type of circuit may readily be obtained. Condenser C1 will have a voltage working rating of about 200, for small tubes, and a capacity of about 1,000 to 2,000 mfd. If the capacity is much reduced, the flash will be weakened or absent. For C2, the ordinary type of paper block condenser of about 1 mfd. is suitable. The voltage at the firing contacts is not sufficiently high to be dangerous, but proper care should be taken with the insulation throughout, or a severe shock may be obtained from C1, or the secondary of the initiating transformer, where 3,000 to 5,000 V. may be developed. The condensers should always be discharged before touching bare connections, etc.

A tube of this type can be flashed repeatedly at short intervals, and the flash is of extremely short duration. For 200 V. operation, the Mazda SF15 is suitable, and will operate on voltages under 200. As with the other guns, the components may be mounted in a suitable case, with plug and socket connectors for synchronising leads, battery supplies, etc.

Supply Unit

Small deaf-aid batteries will have the advantage of portability, but are fairly costly as several batteries, wired in series, are required to make up the necessary voltage. A longer period of use can be obtained from two 90 V. H.T. type-batteries of larger size.

If mains are available, the supply may be obtained from a transformer and rectifier, as shown in Fig. 6. This is of great advantage when using the unit indoors. The

output should be of suitable voltage for the tube and condenser employed. As the transformer will virtually be operating under a "no load" condition when C1 is fully charged, the voltage obtained will be the peak rating, which is roughly one-third greater than the normal rating. If, however, the output is too high, it can readily be reduced by wiring two resistors in a

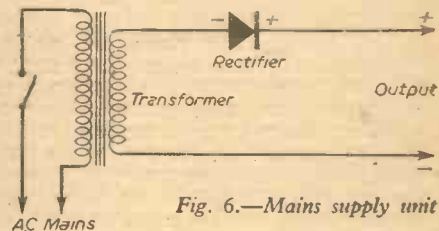

Fig. 6.—Mains supply unit.

potential-divider circuit. A small tube such as that mentioned will require about 175 to 200 V. Larger tubes such as the FA6 will require 600 to 1,000 V. or more, with condensers of appropriate voltage rating.

Some guns of this type employ a vibrator circuit. In this, an accumulator supplies 4 or 6 V. to the primary of a transformer, the current being interrupted by the vibrator. The transformer steps this voltage up to a suitable figure, and the A.C. output is changed to D.C. by a rectifier or pair of rectifiers. However, this type of circuit is scarcely justified when dry batteries can be used, and is mainly intended for the portable operation of high-voltage tubes.

An All-metal Radiator Blind

An Adaptable Unit of the Louvre Type By C. W. BALLARD, B.Sc.

THE use of a radiator blind on a car confers several advantages. Normal engine running temperature is reached more quickly, thus enabling minimum use of choke with consequent saving in petrol and reduction of engine wear; in winter, engine temperature may be maintained at optimum value, whilst, when the car is parked, the rate of cooling is lessened.

Two main types of radiator blind utilise either a roller blind, the unit being available as an accessory, or metal louvres usually arranged vertically and fitted to the car when made. The roller-blind type suffers from certain disadvantages; it is expensive, it may not be operable at high road speeds owing to wind pressure and the fabric blind material has limited life owing to the wet, hot and dusty conditions in which it is called upon to function, as well as, in some designs, to mechanical wear.

For these reasons the all-metal louvre or shutter type was chosen when designing a blind for the Morris 8 Series E for which no commercial blind was available. The louvres or slats are arranged horizontally in order to fit conveniently into the space between the radiator and the grille, and are of graded width in order to be least in number. The vertical flanges projecting forward from the sides of the block make attachment of the unit particularly simple. With suitable alterations of dimensions the unit may be fitted to any car where there is space, e.g., Morris 10, Ford 8 and 10, Standard 9 and 12, Austin A40 Somerset and A70 Hereford. In the case of the Austin A40 Devon and A70 Hampshire the unit would have to be arranged in two halves on account of the metal plate half way up the radiator front bearing the lock and safety catch for the bonnet. Where possible it may, with advantage, be fitted so that the slats open

downward when in the event of cable failure the blind falls open. In other cases it may be more convenient to arrange the slats vertically.

Shutter Assembly

Fig. 1 shows the essential features of the shutter assembly. The slats of 1/16in. aluminium alloy sheet are fastened to the slotted hinge pins of 3/4in. copper rod with 6BA nuts and bolts. The hinge pins pass through the alloy angle vertical members and

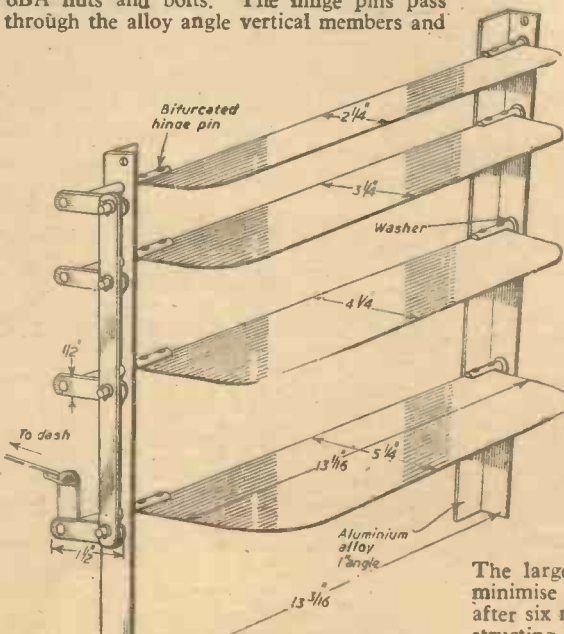

Fig. 1.—General view of the shutter unit.

are moved in unison by means of a link of 3/8in. alloy attached to cranks of the same material and anchored by split pins. The cranks are retarded relative to the slats by 15 deg. in order to prevent jamming or locking when the blind is closed. Fig. 2 shows a bifurcated, or slotted crank-pin with crank attached. Fig. 3 shows the adjustable dash control; alternatively a ball chain passing through a keyhole may be used. The side flanges of the radiator are drilled to enable the hinge pins to pass through on the off-side and on both sides for the bolts which fix the vertical angle members to it.

The unit is robust and durable and is operable even at relatively high road speeds.

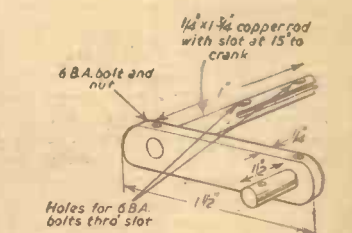

Fig. 2.—Bifurcated crank-pin and crank

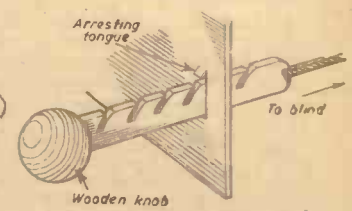

Fig. 3.—Enlarged view of dash control.

The large bearing surfaces were chosen to minimise rate of wear; no rattling occurs after six months use. The materials for constructing the blind cost only a few shillings, whilst a few hours suffice for the actual work of construction.

HANDS WANTED...



X-acto

Burlington Hobby Chest

comprises three X-acto knives with a set of interchangeable blades, gouges and routers, a block plane, balsa stripper, steel rule and sanding block. Complete with instructions.

X-acto single Knives from 3/-

X-acto blades are available separately in packets.

5 short blades, straight 2/6

5 short blades, curved 3/9

and 2 long blades, 2/-

Other X-acto Tool Kits from 23/-

Write for illustrated folder to:—

TRIX LTD. (Dept. A), 11 OLD BURLINGTON STREET, LONDON, W.1

... to put to good use the X-acto Burlington Hobby Chest, the finest hobby knives and tools you can buy. The superb cabinet and tools are made in England by folk who know that craftsmen strive always for perfection. Every tool and blade designed for a specific job, scalpel-sharp and made of the finest surgical steel.

See your nearest X-acto Agent—test the balance and see the beautiful workmanship of these tools for yourself, and you will realise why they bring

more skill to

your fingertips



G.A.G.

AMPLIFIERS.—Ex W.D., but new and unused. Type 1271: Contain EF36, two transformers, relay (400 ohms), v/controls, condensers and resistors. Case measures 5in. x 5in. **BARGAIN PRICE, 9/6. Post 1/6.**

HEAD-PHONES. Store soiled but all tested. Complete with metal-clad Tannoy microphone. **ONLY 6/9.** Also DLR types at 8/9. Post 1/- per pair. Single ear-pieces at 2/6. Post 6d.

MICRO-AMMETERS. New and boxed. Movement by Weston. Moving coil, 100 micro-amps. full scale deflection. **28/6.** Also used (but tested) at 12/9. Post 1/9 each.

BURGLAR ALARMS.—Brand new. Made by Truvox. Still in maker's boxes. Ideal burglar alarms, warning bells, etc. Work off 4½ volts. Fool-proof. **12/9. Post 2/6.**

TELESCOPIC MASTS.—Ex W.D., but unused. Extend to 7ft. 6in. Base diameter ½in., tip ¼in. Ideal aeriels, heavy fishing rods, etc. **7/9, post 1/3.**

TUNING CONDENSERS.—Store soiled, but all tested. Standard size. .0005 mfd. ½in. spindle. Two gang. **2/9 each, post 6d. BARGAIN OFFER 3 for 7/-.**

FIXED CONDENSERS.—Various sizes, from .0005 mfd. to .25 mfd. 350, 450, 500, 1,000 and 3,000 VDC. In mixed parcels of 20 for 5/-, 45 for 10/-, or 100 for £1.

SEATS.—Office type chairs, iron frame, leather upholstery, tilting back-rest. Adequate stand easily made from wood or metal. **CLEARANCE PRICE, 12/9.** Post 2/3. Single bucket seats, moquette upholstery, spring filled at 37/6, Dunlopillo filled at 47/6. Carr. 2/6. Luxury type Aircraft passenger seats. Strong construction. Fully adjustable back and neck-rest. Some with fitted chart-boards. **44/6. Carr. 4/6.** Green plush covered seats, spring filled. Complete with backs, at 8/9. Post 2/3.

EXTENSION SPEAKERS.—6½in. P.M. low impedance speaker mounted on latest type baffle stand. Polished and veneered. 5ft. of lead connected ready for immediate use. **19/9. Post 1/9.**

STRING. All brand new. Sisal, hemp or jute 1/6 per 1 lb. ball. Post 9d. These prices are far below cost.

6 VALVE SUPERHET. V.H.F. RECEIVER FOR 7/6. Ex W.D. brand-new condition. 6 channel switching. Receives T.V. and most British and Continental Stations including Police, Fire, Taxis and Amateurs. 30.5 to 40 mc/s. I.F. 7 mc/s. 6 Valves. H.T. 200 Volts at 50 mA, L.T. 13 volts. As the valves have been available ex-W.D. at low prices we are offering the chassis less valves. Complete with valves, **17/6. Post 2/6.** As a Bargain break-up unit it contains the following: 30 ceramic trimmers, 6 ceramic v/holders, 3 Westector rect., 2 transformers, 1 double block condenser, 32 condensers (small), 36 resistances (¼ to 1 Watt), 5-bank Yaxley 6-way switch, 3 coils, 3 I.F.'s. 6 v/cans and covers. Ideal neat chassis, etc.

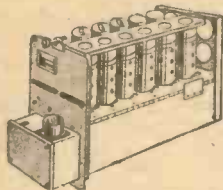

LOUD HAILER. Powerful P.A. system. Brand new, and consists of microphone and combined amplifier/speaker. Iron-clad and waterproof. Works off 12 or 24 volts, therefore independent of electricity failures. Total weight 20 lb. As used by Police and other Public Companies. Our Price **£8.17.6, carriage 5/6.**

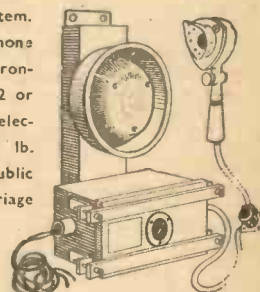

AERIALS.—Copper-plated steel. Interlocking sections to indefinite lengths. **2d. each.**

CRYSTALS.—Brand new, Germanium, made by B.T.H. Long wire ends. **2/3 Post 6d.**

VALVE SALE SURPLUS AND SALVAGE.—All at 8/9. 20D1, 20F2, 6AB8, 807, EAF42, UU3, 6B8, 6G6, 6V6, 6D3, 10P13, 6AR7, 12K8, ECC31, KT8, 35Z4, 1A3, 1A5, 1LC6, 1T4, 1S4, 1S5, 1R5, 6B4, 6F6, 6F15, 10F1, ECC91, EF36, EF50, EL91, EL32, EF91, EY51, KTZ63, KTW61, X66.

WALKIE-TALKIE SETS.—All brand new. Made by Jefferson Travis (U.S.A.) for the Air Ministry, but never unpacked. Still in canvas covers, and packed in individual wooden transit cases. Model UF/1. Visual range. As used by many police and fire forces. Ultra high frequency band of 53-75 mc/s. Complete operation for formal telephone type handset. Runs completely off batteries, or from a vibrator powerpack off one 12-volt supply. Telescopic aerial, non-utility black crackle finish over-all. **SPECIAL PRICE £9.17.6 (power pack 39/6). Carr. 7/6. Price per pair £18.17.6.** Few left.

MICRO SWITCHES.—Brand new. Very latest American type. 250 volts, 3 amps. Can be made to make or break by pressing. Measure only ½in. x ½in. x 1½in. Worth double our **PRICE of 3/6.**

WIRE.—Nickel-chrome. Sealed tins, with run-out mechanism. 50 yds. (.014in.) and 25 yds. (.032in.). **4/6 each.** Also spring steel wire in same sizes at 1/-. Post 6d.

RESISTORS.—Bulgin Super Type Resistance Links. All brand new and in maker's boxes. 240, 300, 400, 500, 1,250, 1,500, 20 K., 25 K., and 30 K.ohms. All 6d. each. Also wirewound resistors made by I.R.C., 1 meg., to 1 per cent., **3/9 each.** Mixed parcel of resistors, popular sizes, ¼ to 2 watts, 25 for 5/-.

C.O.D.
or
C.W.O.

STAMP FOR COMPLETE CATALOGUE
DUKE & Co., 621, ROMFORD ROAD, LONDON, E.12
GRA. 6677

MONEY BACK GUARANTEE

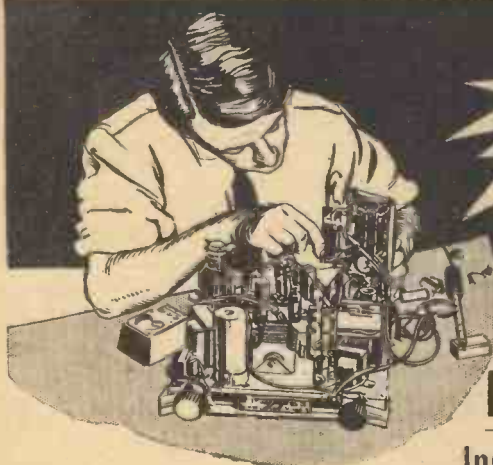

NEW! RADIO, TELEVISION AND ELECTRONICS

LEARN THE PRACTICAL WAY

Instruction *and* Equipment

Here at last is the only *real* way of making home study really successful. Specially prepared equipment, which remains your property, is supplied thus combining theory and practice in the correct educational sequence. Whether your need be for career, hobby or general interest, here is the most efficient method for acquiring knowledge.



POST THIS COUPON TODAY

Please send me your **FREE** book on *Practical Courses*.
To: E.M.I. INSTITUTES, Dept. 144X,
43 Grove Park Road, Chiswick, W.4.

NAME _____
ADDRESS _____

We will not worry you with personal visits.

Practical courses in many other subjects including:

Draughtsmanship. Carpentry. Chemistry. Photography. Commercial Art.

Also over 150 standard courses including: Aerodynamics. Automobile Eng. Jig & Tool Design. Mechanical Eng. Quantity Surveying. Surveying. Radar. Telecommunications, etc.

EMI INSTITUTES

the only Postal College which is part of a world-wide Industrial Organisation.

PROBLEMS OF SPACE TRAVEL

A Brief Account of Some of the Factors to be Considered

By "PHYSICIST"

MOST of us would like to take a trip to the moon, and, of course, everyone of us has a vivid mental picture of the space ship which is going to take us there. Have we not seen it colourfully displayed in magazines, comic strips, and on the films? To be sure, it will be long and narrow, with big fins at the rear and spouting a long trail of flame, smoke, and hot gases, whilst we, the passengers and crew are comfortably installed in the pressurised air-conditioned cabin in the nose of the ship.

We shall be able to look through protec-

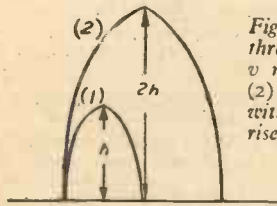

Fig. 1.—(1) Stone thrown with velocity v rises to height h . (2) Stone thrown with velocity $2v$ rises to height $2h$.

tive glasses, back to old Mother Earth as she recedes from us at the alarming speed of 25,000 miles per hour, or perhaps, look out into the blackness of space, relieved by the brightly shining planets and stars which are only overawed by the intense brilliance of the sun.

This story has been told many times now, and the sequence of events is familiar to everyone. It is hardly worth continuing here! Instead, let us, metaphorically speaking, come right down to earth from these flights of fancy and face cold, hard facts.

The Earth's Gravitational Field

A stone thrown into the air loses speed as it rises and ultimately returns to the earth, reaching it with the same speed with which it was thrown (ignoring the effects of air resistance). The faster it is thrown into the air the higher it will go before returning to the ground (Fig. 1).

The reason for this behaviour is well known and is commonly referred to as being due to gravity, but what is not so easily appreciated is that the effect of gravity (or to put it more scientifically, the strength of the earth's gravitational field) decreases with the distance from the earth.

Therefore, as the stone is thrown higher and higher, the force on it due to gravity becomes smaller. Theoretically, it would be possible to throw the stone with such a speed that it rose to a height where the effect of gravity was very small, and its speed at that point was sufficient to overcome all the residual effect of gravity. Such a stone would never return to the earth!

It is quite a simple matter to calculate the speed with which the stone or any other projectile would have to be thrown, to escape from the earth. This speed is approximately 25,000 miles per hour (7 miles per second), and is often referred to as the "escape" velocity. In no way does it depend upon the size or mass of the projectile.

The basic problem of space travel can thus be quite simply stated as the attainment of a speed of 25,000 m.p.h. Once the projectile reaches this speed at some point in its flight from the earth, it will inevitably free itself from the gravitational attraction of the earth. Whilst the basic problem can be so simply expressed, however, its solution still eludes us.

Possible Means of Achieving the Escape Velocity

It is almost 100 years since Jules Verne postulated a "moon gun" which would fire a cannon ball with a passenger to the moon, but such a project could never become a practical proposition because of the enormous dimensions the gun would have, even if the projectile were fired from a height of several thousand feet, to escape most of the extremely high air resistance which would be exerted on it as it left the gun nozzle, travelling at 25,000 m.p.h.

Fortunately, there is a possible alternative in the rocket which does not attain its greatest speed at the start of its flight. In fact, it is quite easy to start at a low speed and maintain this until it has cleared most of the earth's atmosphere, when the full thrust can be developed. It is helpful to remember that the rocket motor does not rely on the atmosphere to develop maximum

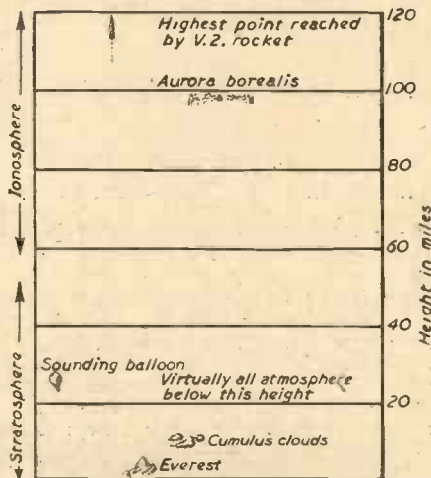

Fig. 2.—The earth's atmosphere and space.

efficiency and that the rocket moves forward, is due to the reaction force produced by the efflux of the hot gases from the combustion chamber.

The Mass Ratio of the Rocket

The size of the rocket is not in itself an indication of what the rocket can do. Naturally, a larger rocket will develop a larger thrust than a small one, but the important characteristic is the ratio between the weight of the rocket and the weight of the fuel it can hold.

Obviously the greater amount of fuel in a rocket of a certain mass the farther it can go. It is useful to express this relationship by the ratio,

M_T where M_T = mass of the rocket at take-off, M_R and M_N = mass of the rocket without fuel, and this is usually called the "mass ratio."

Exhaust Velocity

In rocket motors the thrust is produced by the rapid liberation of gases which stream forth from the combustion chamber with a certain velocity which is known as the "exhaust velocity." Knowing the limitations inherent in the design of rocket motors,

it is possible to calculate a theoretical value for the exhaust velocity for any fuel whose chemical constitution is known.

With the best possible fuel known to date, viz., a mixture of hydrogen and oxygen, the exhaust velocity will not be much greater than 5,000ft. per second, and there are very serious drawbacks which have precluded the use of this fuel. For all practical fuels the exhaust velocity is never likely to exceed 4,000ft. per second, and 5,000ft. per second is about all that can be hoped for.

The importance of having a high exhaust velocity can be demonstrated by the following formula, which relates the mass ratio to the exhaust velocity c , and the rocket velocity v ,

$$\frac{M_T}{M_R} = e^{v/c}$$

Now, remembering that for the rocket to escape from the earth, it must attain a velocity of 7 miles per second (=40,000ft. per second approx.), and assuming that the highest practical value for the exhaust-velocity using chemical fuels is 8,000ft. per second, it follows that

$$\frac{M_T}{M_R} = \frac{40,000}{e^{8,000}} = e^5 \approx 148.$$

This is, if anything, somewhat of an underestimate because of the high value we assumed for the exhaust velocity.

Mass Ratio for a One-step Rocket to Escape From the Earth

The value for the mass ratio derived above implies that for a one-step rocket weighing one ton a fuel load of 147 tons would be necessary to ensure its escape from the earth. Clearly, this is far beyond the realm of engineering endeavour; in fact, anything with a mass ratio much in excess of 5:1 would prove impossible to build.

The V2, which was, from the German point of view, one of their most successful rockets, had a mass ratio of 3:1 and a total weight of 12 tons.

Exhaust Velocity for a One-step Rocket of Mass Ratio 5:1 to Escape From the Earth

If we accept the limitation imposed by the constructional difficulties and say that the

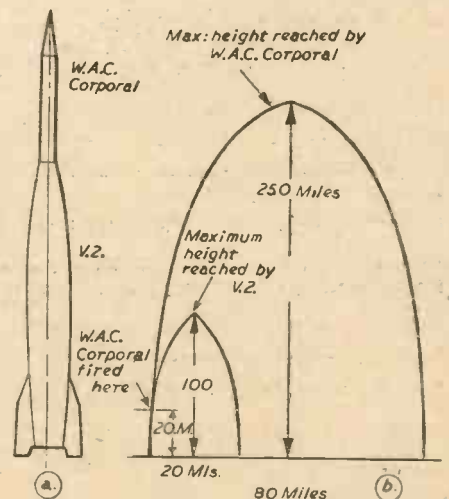

Fig. 3.—(a) Outline of a two-step rocket which rose to 250 miles. (b) Paths in space taken by the components of this rocket.

mass ratio cannot exceed 5 : 1, the exhaust velocity necessary to give the rocket a velocity of 40,000ft. per second, reaches the fantastic figure of 25,000ft. per second, which is some five times higher than present practical exhaust velocities.

Atomic-powered Rocket Motor

What hope is there then for a rocket to escape from the earth? Suggestions have been made which entail the use of an atomic reactor to provide electrical power, which would accelerate gaseous atoms to 300,000ft. per second, but there are no grounds whatsoever for assuming that this is even a probability.

We are, therefore, forced to the conclusion that a one-step rocket will never be fired from the earth's surface and escape from the earth, using any known chemical fuel.

Multi-step Rockets

There are, however, possible ways of overcoming this difficulty. One is, by the use of a multi-step rocket built from several separate rockets, arranged so that the remaining steps are fired out of the last step in succession, as the maximum velocity for each step is reached. In this way, velocities greatly in excess of the exhaust velocity can be reached—but only at a price, for each subsequent step must be considerably less in mass than the preceding one, or the overall weight of the rocket becomes enormous!

A step rocket has not yet been constructed which can escape from the earth, but it is expected that a small rocket, the final step weighing no more than a few pounds and boosted by two further steps, will be fired to hit the moon within the next 50 years. There are high hopes that its impact with the moon will be observed from the earth by placing a small explosive charge in the nose of the rocket which will scatter a white powder about a part of the moon's surface.

Oberth has calculated that a manned space-ship to reach the moon would comprise a three-step rocket and would be approximately 500ft. long and between 30 and 40ft. in diameter.

Actual Two-step Rocket Trials

Recent tests carried out at the White Sands Rocket Range in New Mexico show how some of the problems of multi-step rocket design are being met.

A two-step rocket made of a modified V2 weighing 12 tons and a much smaller rocket, the W.A.C. Corporal, weighing 6 cwt. and of which only 25lb. was payload (instruments) has been fired to a total height of 250 miles, before crashing back to the earth, Fig. 3. The total time of flight was 12 mins. The V2 was fired at ground level and the W.A.C. Corporal was launched from it when it was 20 miles high and travelling at approximately 1 mile per second.

Further tests have been made, presumably to study the effects of cosmic radiation on materials, and small animals, suitably anaesthetised, have been carried. As far as is known, they have suffered no ill-effects from their flight into space. In later tests, a height of over 300 miles has been reached and a film record of the appearance of the earth was made during the flight.

The Earth Satellite

These investigations have formed part of a programme announced by the United States Secretary of Defence in 1948 and known as the Earth Satellite Vehicle Programme. The declared objective being the developments of small rockets to travel in fixed orbits round the earth.

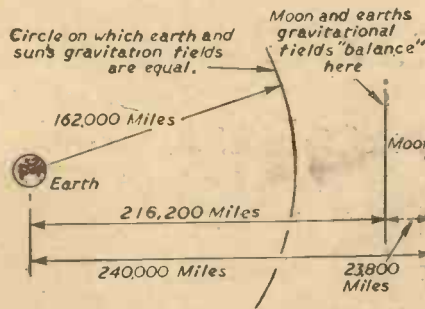

Fig. 4.—Distribution of gravitational fields of earth and moon. A rocket from the earth is attracted back to the earth until it crosses the vertical line, then it is attracted towards the moon.

The idea of a man-made projectile travelling round the earth in its own orbit, at first sight appears fantastic, until it is remembered that, after all, the moon is merely a satellite of the earth and it moves continuously in a fixed orbit. The earth also is a satellite of the sun, moving in its orbit at 18.5 miles per second.

Provided that the rocket could be fired with sufficient velocity to clear the earth's atmosphere and directed so that its direction of motion became tangential to the earth's surface, it would ultimately travel round the

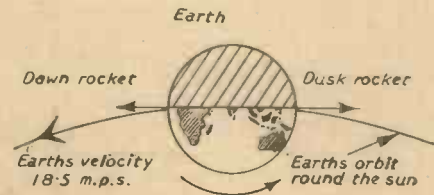

Fig. 5.—Showing how the earth's velocity may be utilised in space travel. (a) For a rocket launched vertically at dawn, resultant velocity is the sum of its velocity relative to the earth and the earth's velocity; this rocket will move in a smaller orbit than the earth. (b) For a rocket launched vertically at dusk, resultant velocity is the difference of its velocity relative to the earth and the earth's velocity; this rocket will move in a larger orbit than the earth.

earth and in the absence of the frictional resistance of the atmosphere, it would continue in its orbit indefinitely.

The mathematical relationship between the diameter of the orbit and the velocity of the rocket can be simply and accurately deduced, so that the rocket can be designed to travel

in any selected orbit, provided it is outside the limit of the earth's atmosphere.

Naturally, such a rocket would be used as a "space laboratory," crammed with instruments their reading being transmitted by radio to the earth. In this manner, a welter of information about the conditions in space would quickly be amassed.

To the more ambitious minded devotees of future space travel, this experiment is looked upon as merely the opening phase in the development of a space-ship station to which fuel and men would be ferried from the earth by rocket, so that interplanetary rockets could refuel there without returning to the earth. Admittedly, in this way, larger rockets would be able to escape from the earth, but the engineering problems involved in assembling the satellite space-station are virtually insuperable and whether it will ever become a reality is, to say the least, highly conjectural.

Surprising as it may seem, if manned space-ships can reach the moon, travel to the other planets should quickly follow, for it must be remembered, that the earth is moving at 18.5 miles per second round the sun, and that a rocket leaving the earth will also be travelling at this speed and by arranging the start of the trip to coincide with a favourable position of the earth with respect to the planet and starting the journey at the right time of the day, it should be possible to utilise a large part of this velocity, Fig. 5. The complicating factor here, is likely to be the time taken to make the trip, which will be several weeks or months at least.

Food for the trip would present no serious obstacle: tinned and bottled food would solve all the feeding problems of the crew and water supplies could be carried without difficulty, but the problem of air supply for the pressurised cabin has elicited several ingenious suggestions. Best of all, is the use of plants which absorb carbon dioxide and liberate oxygen, to ensure a balanced atmosphere. Excess humidity, produced by perspiration by the crew, could be removed by circulating the air through a pipe outside the rocket body, to freeze out the water vapour.

Pressurised suits would enable the crew to move outside the cabin when necessary and leave the rocket when it had reached its destination.

This is all very well, and shows the undying adventurousness of man, but it is all far from reality and belongs to the distant, if not infinite, future. Nevertheless, the universal interest and activity which is being shown is to be encouraged, for, there is the remote possibility, that some as yet unknown scientific discovery may make what is now seemingly impossible; a practical proposition.

SOLVE YOUR CHRISTMAS GIFT PROBLEMS THIS EASY AND EFFECTIVE WAY

The choice of Christmas Gifts for friends and relations is always a difficult business. Why not solve the problem this year in a novel, yet practical, way?

Look now at your Christmas list and you will see at once more than one relative or friend who would be delighted to receive **PRACTICAL MECHANICS** regularly. It is simple to arrange for we can send subscriptions to any address, at home or abroad, at the annual rate of 14s. (Canada 13s.).

An attractive Greetings Card will be sent in your name with the first Gift Copy.

Just write to the Subscription Manager (Dept. G.1), **PRACTICAL MECHANICS**, Tower House, Southampton Street, Strand, London, W.C.2, enclosing the names and addresses of your friends, with remittance to cover, and we will do the rest. Remember, a Christmas Subscription for **PRACTICAL MECHANICS** is a Gift which will give pleasure and act as a reminder of your good wishes the whole year through.

Telephone: MUSEUM 9594

H. FRANKS

58-60, New Oxford St., London, W.C.1

One Minute from
Tottenham Court Rd. Station

12/24 VOLTS HOOVER BLOWER MOTORS, Ref. 10KP/115, as recommended for car heaters in a recent issue. Price 27/8 each.

TUFNOL PULLEYS. Fitted ball races, external diam., 2 1/4 in. internal diam. 3/16 in., 2/9 each, 30/- per doz.

DITTO, 4 1/4 in. external, 1 1/4 in. internal, 5/- each, 55/- per doz. 2,000 of both types available.

MINIATURE IMPULSE MOTORS made by "Gents" size 3 x 2 x 1 1/4 in., suitable for operating models, switches, etc., operates off 46v. a.c./d.c. and is very powerful for its size. Price 8/6 each, post paid.

SYNCHRONOUS CLOCK UNITS. Self-starting 200-250 v. a.c. 50 cycle, fitted Sangamo motors consumption 24 watts, size 2 1/4 in. diam., 2 in. deep, geared 1 rev. 60 mins. friction reset. Ideal movements for electric clocks. With gear train and 5 in. hands. Price 22/6 each, post paid.

SANGAMO MODEL S7 SYNCHRONOUS MOTORS, 200/250 v. a.c. 50 cycles, final speed 1 r.p.m., 27/6 each.

SANGAMO MOTOR UNITS, MODEL 7, final speed 1 rev. 24 hrs. 200/250 v. a.c. 50 cycles, 27/8 each.

SANGAMO MOTOR UNITS, MODEL 7, final speed 1 rev. per 7 days, 200/250 v. a.c. 50 cycles, 30/- each.

EX-AIR MIN. GEAR PUMPS. Type RFP/1, made by Rolls-Royce, size approx. 6 x 5 1/2 x 5 1/2 in. Price 30/- each, post paid.

STEP-DOWN TRANSFORMERS, input 100/230 v. A.C. 50 cycles, output 4.2, 4.2 v., 10 amps., ideal for soil heating, spot welding, etc., 35/- each.

SELECTORS, Type 10K/13045, fitted cam-operated contacts, 2 1/4 in. plastic gear, 12/24 volts D.C. operated, 8/6 each.

FOUR-WAY SELECTOR UNITS, Ref. 5D/832, manual or electrical, 12/24 volts D.C. operation, fitted impulse relay working rotary counter one to four, with cams operating contacts, 17/8 each.

HAND GENERATOR POWER UNITS, Type No. 7 ZA 17571, giving an output of 9 volts D.C. at 3 1/4 amps. for charging. These are unboxed and housed in metal cabinet 17 x 10 x 7 in., 47/6.

LONDEX RELAYS, Type 220, Ref. No. 10F/494, two heavy break contacts, 24 volts, fitted in metal cases, 4 in. x 4 in. x 2 1/4 in., 8/6 each.

6-VOLT LONDEX RELAYS, with 2 break contacts, fitted 4-way Jones socket, 3/- each, 40/- per doz.

HALF-WAVE TRANSFORMERS, input 230 volts A.C., 50 cycles output, 250 volts, 60 ma., 6.3 volts, 1 1/2 amps., 11/8 each.

HIGH QUALITY ex-A.M. VACUUM PUMPS, size 1 1/2 x 4 in. x 4 in. approx. Flange mounting, weight 6 1/2 lb., spline shaft 2 1/2 in. long, 1/4 in. diameter; needs a 1/2 h.p. motor to drive same. Price 37/6 each.

SLIDING RESISTANCES. Enclosed type 20 OHMS 2.3 amp. Price 22/6 each.

FEATHERING PUMPS, 24 volts D.C. operated, delivery 60 gallons per hour, overall length 10 1/4 in., 2 1/4 in. diam., inlet 1/4 in. diam., outlet 1/4 in. diam., 50/- each.

AIR TEMPERATURE GAUGES, Ref. No. 6A/510, fitted Mercedes 4 in. x 4 in. approx. Flange mounting, type. Reading -30/0/50+ Centigrade. Suitable for greenhouses, etc., 18/6.

SYNCHRONOUS MOTORS, 200/250v. a.c. 50 cys. with gear-trains. Final speed 1 rev. per hour. Ex-Time Operated Units by well-known makers, size 3 1/2 x 3 1/2 in. Price 21/6 post paid.

"KLAXON." 24 Volts d.c. shunt wound 1/20th h.p. motors, 2,500 r.p.m. continuous rating, 40/- each.

RECTIFIER UNITS, input 200/250 volts, a.c., 50 cycles, output 24 volts d.c. 3 1/2 amp., 24 each.

PREDICTOR UNITS. Fitted four variable speed gear-boxes, 115 volt A.C. motor, numerous worm gears, right-angle gears, approx. 78 ball-races, etc. weight 78 lbs., cost £300 each to make. New in original cases, £11 each.

TRIPLEX GLASS DISCS, 9 1/4 in. diam., 3/16 in. thick, ideal for Port-holes, etc. 3/6 each, 40/- per doz.

VARIABLE RHEOSTATS, fitted vernier control, 50 OHMS, 1 amp., all new unused. Price 15/- each, post paid.

CLOCKWORK MOVEMENTS fitted "VENNER" escapement, runs 10 hours one full wind, final speed 1 rev. 75 secs. Price 9/- each, post paid.

"STANCOR." U.S.A. 2.5 K.V.A. 50/60 cycle auto-transformers. Input, 115/250 v. Output, 110 v. Completely shrouded. £11 each.

FULL MAILING LIST PRICE 6D.

KARLENITE PLASTIC MARBLE

Crystalline! Veined! and sets Rock Hard!



Karlenite Cast from Flexible Mould
Simulating Carrara marble.

KARLENITE is an entirely new artificial stone plastic for casting Book-ends, Ash Trays, Wall Vases, Statuettes, Plaques, etc.

'Karlenite' sets rock-hard with a scintillating crystalline structure like marble or alabaster for colour, veining, texture density and hardness. It is enormously strong, highly resistant to heat and impervious to water. Literally any type of veining can be simulated in any combination of colours, and a wide range of 'Veining Pigments' is available for this purpose.

Make your own

Flexible Rubber Moulds

Infinite repetition casting. Perfect detail!

ELASTOMOLD, PLASTIMOLD and RESILOMOLD are synthetic rubber materials for making permanent flexible moulds. Ideal for repetition casting of Book-ends, Wall Plaques, Statuettes, Ornaments and Models, in quantities of dozens, hundreds or thousands as required.

The moulds can be prepared from models made of Wood, Metal, Plaster, Stone, Glass, Earthenware, Ivory, etc., and will faithfully reproduce even the most minute details or ornamentation and surface texture. Elastomold, Plastimold and Resilomold are equally suitable for casting articles in Cement, Plaster or Karlenite and have great dimensional stability but flex easily for the release of cast or undercuts. Whilst the moulds are virtually indestructible, the material is fully recoverable and may be used again and again for making new moulds. Both moulding and casting methods are incredibly simple and do not need any expense for special apparatus.

Karlenite Cast from Flexible Mould

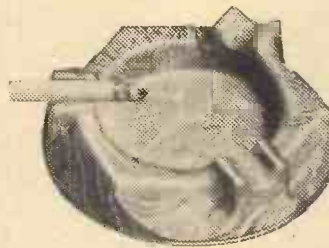

KARLENA accessories for Modern Art Moulding

MENISCOLOID

For completely eliminating air pockets and blowholes in plaster. 'Meniscoid' is a powerful agent for reducing 'surface tension.' When added in minute quantities to plaster it immediately releases all trapped air and causes the plaster to flow into the crevices of the mould.

Water activated with 'Meniscoid' readily reduces 'surface tension,' even on wax, whereas untreated water contracts into beads when applied to a greasy surface. 'Meniscoid' is essential for accurate plaster casting, especially for fine detail work and particularly when using greasy moulds. It adds practically nothing to production costs.

'Karlena' offers a pattern-making service by highly talented sculptors. Moulds prepared to customers' own specifications.

larily when using greasy moulds. It adds practically nothing to production costs.

STONAX

A stone-hard synthetic wax for impregnating plaster casts. Gives a non-scratch, non-smear, high gloss finish.

AMAX 109

Plaster hardener. This complex chemical salt renders ordinary plaster harder and stronger than 14-day concrete and is most economical in use.

GLASIC

A most effective glazing and waterproofing agent for cement and natural stone. Renders surfaces completely impervious to oil and water, etc.; and also resistant to heat, abrasion and chemical attack. Simple to apply either by brushing or immersion.

Send for full details of this new Moulding and Casting technique. Invaluable for students, hobbyists, sculptors and craft workers.

KARLENA ART STONE COMPANY LTD.

Plastics 2.F. Division

55 DEANS GATE ARCADE, DEANS GATE, MANCHESTER, 3

SPECIAL OFFERS

DOUBLE READING AMMETER.—In leather case, A.C./D.C. reading 3 and 15 amps., 2 1/4 in. dial, portable type, with test leads. 22/6, post 1/-.

AMMETER.—2 1/4 in. Flush 0/25 amps. Moving Iron. D.C. 7/6, post 1/-.

MILLIAMMETERS.—Moving Coil. D.C. 2 1/4 in. Flush 0/30, 0/200, 0/250, 12/6; 3 1/4 in. Flush, reading 150-0-1,500, a very useful meter with a good open scale. 22/6, post 1/-.

MAINS TRANSFORMER.—200/250 volt, with output of 12 volt 10 amps., well made in metal case 9 1/2 in. x 5 1/2 in. x 4 in. with switch, plug, etc. 50/-, post 2/6.

VOLTAGE REGULATORS.—Input 230 volt A.C. 21 amps., output 57.5 to 228 volts in 16 steps. With current limiting Reactor. 1/0.

PORTABLE ELECTRIC BLOWERS.—220/230 volts 220 watt. Completely enclosed. 8ft. flexible hose and nozzle. 7yds. C.T.S. Flex. Many uses where clean, dry air is required. 27/10/-.

CLOCKWORK MECHANISM.—Precision made movement with contacts making and breaking twice per second, can be operated by switching on and off lamps, etc. Brand new in sound-proof cabinets, 12/6, post 1/6.

INSPECTION LAMP.—Complete with Battery Case. Fits on forehead. Leaves both hands free. 7/6, post 1/-.

VEHICLE COIL SPEAKERS.—3 1/2 in. x 1 1/4 in. x 1 1/4 in. Very useful, 10/-, post 6d.

ACFIL PUMPS.—These pumps enable you to fill all accumulators on the bench with the carboy at floor level. Brand new, only 30/-, post 2/-.

P.M. SPEAKERS.—In cases, ideal for extension speakers, 6 1/4 in., 30/-; 5 in., 17/6, postage 2/-.

THERMOSTAT SWITCH.—Bimetal type in sealed glass tube, 2 1/4 in. x 1/4 in. 30 deg. Cent. Ideal for Aquariums, Wax and Oil Baths, Gluepots, etc. Will control 1 amp. at 240 v. 5/- each, post 6d.

THERMOSTAT.—Satchwell 12 in. stem., 0.250 v. A.C./D.C. 15 amps. A.C., 1 amp. D.C. 10 to 90 deg. Cent., 35/-, post 1/6.

"ELF" **CIRCUIT BREAKER**, 220 volts, 2 amps. Overload circuit, then mains, switch off. Very useful on test bench. Size 3 1/4 in. round, 10/6, post 1/-.

LOW VOLTAGE CIRCUIT TESTER.—A self-contained unit for making a complete and rapid check of the generator-battery circuit of a vehicle. Battery voltage, regulator and cut-out settings and generator performance can all be easily determined. American made. Complete with instruction book. £5/10/0, post 2/-.

BATTERY TESTER.—Complete in case with heavy current test probe 200 amperes. Plate selector switch with 7 positions, enabling the test to be made in accordance with the number of plates per cell. Meter with coloured scale indication, 70/-, post 2/-.

HAND GENERATOR or Battery Charger.—Output D.C. at 4 amps. Contained in a strong metal case with automatic cut-out, very useful where no mains are available, could be converted to a wind charger. Only 30/-, carriage 5/-.

BLOWER MOTORS.—Dual voltage, 12 24 10 KB/15 recommended for car heaters, 21/-, post 2/-.

BALL RACES.—No EE2, 1 1/4 in. x 3/4 in., post free.

THRUST RACES.—13/16 in. x 1/4 in., 1/6, post free.

VOLTMETERS.—0-300 A.C. Moving Iron 3 1/4 in. Flush or Surface Type, 25/-; 0-300 Flush D.C. Moving Coil, 10/6; 0-20, 2 1/4 in. Flush Moving Coil, 7/6; 0-40 2 1/4 in. Flush M.C. 10/6; post 1/-.

BATTERY CHARGER "WESTALITE". Input 100/250 v. Output 12, 15, 20, variable metered output, fused, worth 23/-. Our price while they last, £15. Carr. & Pkg. 15/-.

ACCUMULATOR CHARGERS, 230 v. A.C. In black plastic case, fuses and meter, 6 and 12 volts at 4 amps. Bargain Price, 24/19/6. Pkg. & carr. 5/-.

RECTIFIER UNIT, P.O. type. Input 200/250 volts A.C. Output 50 volts 0.75 amps., D.C. Westinghouse, 70/-, carriage 10/-.

RECTIFIER UNIT.—Input 230 volts. Output 12-0-12 volts 1 ampere, 50/-, packing and carriage, 5/-.

PORTABLE TEST METER.—Just the job for the home constructor, in neat case, 6 in. x 5 in. x 4 in. Reading 1.5, 3, 150 volts; 6 and 60 mA. D.C., 5 k and 25 k ohms, 25/- each to clear. Post 1/6.

SLOW MOTION DIALS.—6 in. Scaled 0-100, reduction 200 to 1 or direct, ideal for wavemeters, signal generators, etc. Our price, while they last, 5/6, post 1/-.

FLASHING SWITCH UNIT with 6 contacts. Full rotation 60 seconds, operated by a Sangamo Synchronous Motor, 230 volts. A.C. 2 watts. In metal case, 3 in. x 2 1/4 in. x 2 1/4 in., 15/-, post 1/-.

SWITCHES.—A row of 5 in a flush mounting bakelite moulding 5 1/4 in. x 1 1/4 in. x 2 1/4 in. Ideal for model railways, etc., 5/6, post 6d.

24-VOLT MOTOR with reduction gear and cam-operated contacts, 15/6, post 1/-.

24-VOLT D.C. MOTORS with double ended shaft 2 1/4 in. x 3 in., 8/6, post 1/-.

P.W.M. FLEX.—Input 230 volts, approx. 25-yr. coils, 7/6, post 1/-.

HAND TELEPHONE.—Brand new with cord, 15/- each, post 1/6.

MASTS, TELESCOPIC.—Extending to 12ft. in 7 sections, 15/6, post 1/6.

VOLTMETERS, CELL TESTING.—3-0-3 volts Moving Coil D.C. complete with test leads in Leather case, 35/-, post 1/-.

METRO-VICK AUTO TRANSFORMERS.—230/115 v., 500 watt, totally enclosed, 44/10/-.

Comprehensive List Now Ready 6d.

WILCO ELECTRONICS

DEPT. P.M., 204, LOWER ADDISCOMBE ROAD, CROYDON.

HIGHSTONE UTILITIES



Crystal Sets. Our latest Model is a real radio receiver, which is fitted with a permanent crystal detector. Why not have a set in your own room? 12/6, post 8d. De Luxe Receiver in polished oak cabinet, 18/6, post 1/-.

Spare Permanent Detectors, 2/- each. When ordered separately, 2/6. With clips and screws, 2/10, post 3d. **Headphones** brand new, 3/- Brown, E.C. etc., 15/- 25/-, and super-sensitive, 30/- a pair, post 1/-.

New Headphones, 10/- a pair. Balanced armature type (very sensitive), 12/6 a pair. Both post, 1/-.

New Single Earpieces, 3/6. Bal. armature type, 4/6; ex-R.A.F. earpiece, 2/6, post 4d. **Headphones**, in good order, 6/- (better quality, 7/6). **Post 1/-** Headphones with moving coil mike, 15/-. Similar phones with throat mikes, 12/6, post 1/-.

Headphone Cords, 1/3 a pair, post 3d. **Replacement Bands,** 1/3, post 4d. **Wire Bands,** 6d.

(All Headphones listed are suitable for use with our Crystal Sets.)



Bell Transformers. These guaranteed transformers work from any A.C. Mains, giving 3, 5, or 8 volts output at 1 amp, operating bell, buzzer or bell. Will supply light in bedroom or ladder, etc. **PRICE** 9/-, post 8d. **BELLS** for use with either the above or batteries, 6/6, post 6d. "Big Ben" Chimes. Housed in Cream Plastic Case. Easily connected to give Two-Note Chime from front door and Single Note from Rear. Operated from 6-9 volt Batteries or Transformer (shown above), 23/-, post 1/-.

Ex-R.A.F. 2-valve (2-volt) Microphone Amplifiers as used in plane inter-com., in self-contained metal case; can be used to make up a deaf-aid outfit. Inter-communication system or a crystal set; complete with valves and fitting instructions. 20/-, post 2/-. Useful wooden box with partitions to hold amplifier, 2/- extra. Ditto, less valves, 10/-. One-valve amplifier, complete with valve, 10/6, post 1/6.

Hand Microphones, with switch in handle and lead, 4/6. **Tannoy, 6/-** Similar instrument, moving coil, 7/6, post 1/-.

Sparkling Plug Neon Testers with vest-pocket clip, 3/3, and with gauge, 3/6, post 3d. **S.B.C. Neon Indicator Lamps**, for use on mains showing "live" side of switches, etc., 3/6, post 4d. **Neon Indicator**, complete with condenser (pencil type), with vest-pocket clip, indispensable for electricians, etc., 7/6, post 5d.



Soldering Irons. Our new streamlined iron is fitted with a post 6d. **Standard Iron** with adjustable bit, 200/250 v., 50 watts, 12/6, post 6d. **Heavy Duty Iron,** 150 watts, 16/6, post 8d. All parts replaceable and fully guaranteed. **Small Soldering Irons**, for use on gas, 1/4, post 4d. **Resin-coated solder** for inter-communication packets or large reels 5/-, post 9d.

Microphones.—Just the thing for impromptu concerts, room-to-room communication, etc. Bakelite table model, 6/9. Suspension type, 3/6. Post 6d. **Mike Buttons** (carbon), 2/-. **Moving Coil, 4/6**; Transformers, 5/-. All post 4d. each.

Rotary Transformers, 24 v. input; Output 1230 v., 2 amp. in one with supplementary, etc., easily converted to run as a high-voltage motor, 25/-, carr. 5/-. Also 12 v. input; Output 6 v., 5 amp.; 150 v., 10 mA.; and 300 v., 20/240 mA., 22/6, carriage 5/-.

Morse Keys.—Standard-size keys wired to work Buzzer or Lamp, 3/-, post 6d. Slightly smaller keys, 2/6, post 4d. **BZZERS,** 3/6 or heavy duty, 4/6, post 5d.

Terminals, brass, 2BA, mounted on strip 6d. pair. .0005 Airspaced Variable Condensers, 2/6, post 4d. .0003 twin gang with trimmers, 2/6, post 4d. 24 volt, 15 m/m. M.E.S. Bulbs for model railways, etc., 1/- each, 10/- doz., post 4d. **Wander Plugs,** Brass, 1/8 doz., post 4d. **Fuses.**—1 amp, 11n., packet of 10, 2/6, post 4d. Also 150 mA. and 250 mA., same price. **Hydrometers,** Standard Type, 8/-, post 6d.

Bargain Parcels, of really useful equipment, containing Switches, Meters, Condensers, Resistances, Phones, etc. 10/- or double assortment, 17/6; treble 25/-, all carriage 2/-. This country only.

Field Intercommunication Sets, complete with ringing hand generator, bell, signal lamp, morse key relay, in strong metal case with circuit diagram, 30/- each, carr. 2/6; 57/6 pair, carr. 3/6. **E.C. 2-C. Telephone Twin Bells,** with box, 5/-, post 9d. Telephone hand generator, with handle, 9/6, post 1/6; Bell, 3/6, post 6d.

Meters, 10 v., 24n. Rectifier (A.C.), in wooden carrying case, 14/6; 15 v., 24 in. m/c, 9/6; 150 v., 2in., m/c, 10/-; 3.5 amp., 2 in. T.C., 6/-; 41 amp., 24n. T.C., in case with switch, 10/-; 10 mA., 2 in., m/c, 7/6; Meter Units containing 2-500 microamp. movements, 7/-, post 1/-.

All meters post extra. Money refunded if not completely satisfied. **HIGHSTONE UTILITIES** 58, New Wanstead, London, E.11. Letters only. New Illustrated List sent on request with 11d. stamp and S.A.E.

29 Gns.—AUTO RADIOGRAM—29 Gns.

Full size walnut Console Cabinet. £11 10s., plus 15s. carriage. 5-valve all mains superhet radio, 3 waveband coloured illuminated scale - fully guaranteed, £8 19s. 6d. plus 7s. 6d. carriage and insurance. Auto change Unit by Collaro with pick-up for long playing and standard records. £11 10s., plus 7s. 6d. carriage and insurance. **Special Offer.** Three Units for 29 gns. or £10 14s. deposit and 12 monthly payments of 22 3s., plus 11 carriage and insurance. Booklet of photos, circuit diagrams, etc., 2/6 (returnable).

BE PREPARED



For a cold winter by making our low cost Electric Blanket. 27 yards of special heater wire and blueprint, 20/- Blueprint only 1/6. Alternatively make a Bed Warmer. Constructional data, 1/6.

MULTI-SPEED MOTOR

Works off A.C./D.C. mains; fitted with gear box, any speed from 1 r.p.m. 12/6, post and packing 1/6.

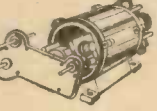

HANDY BATTERY THREE

Constructional data showing how to make useful portable loudspeaker set (total cost 70/-, including cabinet) is available 1/6.

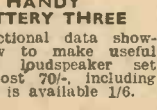

"ELPREQ" WOLSEY 5 VALVE A.C./D.C. SUPERHET

Long medium and short waves, in handsome wooden cabinet. Illuminated glass dial with station names A.V.C. and usual refinements; size 11 in. x 5 1/2 in. x 7 in. with E.V.A. valves and a built-in aerial. 12 months guarantee. £9 5s. 0d. or £3 2s. 0d. deposit and 12/6 monthly. Carriage and insurance 5/-.

MAKE A RADIO

Using our parts in one evening you can make an all mains 4 valve radio with bakelite case, then you will be giving a £12 present which costs you only £6 1s. 6d. or £3 2s. 0d. deposit and 12 monthly payments of 11/6. (Carr. and insurance 6/-).



TOY SEWING MACHINE

Makes real stitches—all metal construction—complete with needle and cotton ready to sew. 22/6 plus 1/6 post and packing.



CRYSTAL SET

Two wave-band bakelite case, germanium crystal case, "Home" and "Light" anywhere with out batteries. 18/- headphones, 15/6 pair.

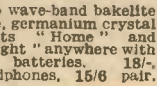

MORSE OUTFIT

Ideal Scout, Guide, Air Cadet, etc., comprises heavy Morse key with buzzer and battery clip on hard wood panel, 7/-.

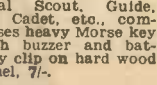

226 FLUORESCENT LIGHTING

Complete kit comprises Hi-craft 40 watts control unit, starter lamp, lamp holders, clips and wiring diagram. Price less tube 22/6, plus 1/6 post with tube 30/-, carriage and insurance 3/6. Tubes 7/6 each carr. free, minimum quantity 6.



Portable, ideal for small dance band, singer, ventriloquist, etc. Complete with hand microphone, built-in speaker, nothing else needed. 9 gns., or £3 4s. 0d. deposit and 12 monthly payments of 13/9.

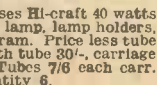

THIS MONTH'S SNIP

Superhet 5-valve three-wave band radio chassis made by BEETHOVEN. A.C. mains working (110 to 250 volts) all MULLARD valves, large illuminated dial, chassis size 9 1/2 x 7 x 8 1/2, complete with ROLA speaker. Ready to work, fully guaranteed, price £7 17s. 6d., carriage and insurance 7/6.

ELECTRONIC PRECISION EQUIPMENT, LTD. (Dept. 1)

42/46, WINDMILL HILL RUISLIP, MIDDX. 29, STROUD GREEN ROAD, FINSBURY PARK. 152/153, FLEET STREET LONDON, E.C.4.

3 SPEED GRAM UNIT

Induction motor, instantly changeable. 33-45-78 revs., £4 10s. 0d. post and insurance 3/6. Precision balanced pick-up with plug-in heads for long playing and standard records, 54/- plus 2/6 post. Both items 27.



BABY ALARM Brings baby's cry to you, mains operated complete with microphone and long cable, 9 gns. or £3 4s. 0d. deposit and 12 monthly payments of 13/9.

ELECTRIC CLOTHES HORSE

Warms room as it dries clothes towels etc.—Chrome plated rails—A.C. or D.C. 650 watts. Size 3 ft. x 3 ft. x 5 in. Made to sell at 12 gns. fully guaranteed only £4 19s. 6d., carr. 7/6.



EVERLASTING GRAMPHONE NEEDLES

Jewel (sapphire) pointed, suit any type of pick-up—precision made—improves quality, eliminates record wear. 3 types, loud, soft, trailer, 3/6 each, 3 for 10/-.

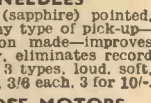

MULTI PURPOSE MOTORS

Works off A.C./D.C. mains or batteries—many speeds—many uses, including battery charging. Data given. 11/6, post and packing 2/-.



SOIL HEATER

Ideal for gardeners, helps plants along, germinates seeds, etc. Complete with wires 47/6, plus 2/6 post.



WIRE WELDER

With totally enclosed transformer, for mains operation, ideal for wire-worker or handyman, 29/6.

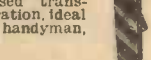

FISHING ROD FROM DINGHY MAST

Tubular aluminium not separate sections, extends like telescope from 15ins. to 9ft. 6/6 each.

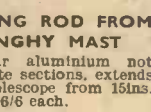

3 TORCHES, 3/9

1. Hand lamp—takes twin cycle battery, with switch and removable coloured discs for signalling. 2. Forehead fixing, miner's lamp type with adjustable headstrap. 3. Round pocket torch with magnifying lens. 3/9 the 3.

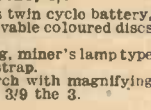

GARAGE HAND LAMP

With stout galvanised wire guard and 12 ft. waterproof flex 9/6, plus 1/- post.

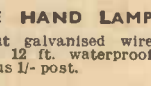

THE SUPERIOR 15in.

up to the minute TV for only £37 10s. 0d. A 20-valve television for the amateur constructor, all components, valves and 15in. Cosmor Cathode Ray Tube costs £37 10s., plus £1 carriage and insurance or £12 10s. deposit and 12 monthly payments of £2 11s. 6d. Constructor's envelope giving full details and blueprint, 7/6. Returnable within 14 days if you think you cannot make the set.

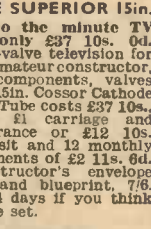

MAINS AMPLIFIER

Portable, ideal for small dance band, singer, ventriloquist, etc. Complete with hand microphone, built-in speaker, nothing else needed. 9 gns., or £3 4s. 0d. deposit and 12 monthly payments of 13/9.

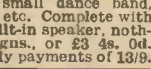

GALPIN'S

ELECTRICAL STORES

408 HIGH ST., LEWISHAM, S.E.13.

Tel.: Lee Green 0309. Nr. Lewisham Hospital.

TERMS: CASH WITH ORDER. NO C.O.D.

All goods sent on 7 days' approval against cash.

EARLY CLOSING DAY THURSDAY

ELECTRIC LIGHT CHECK METERS, useful for subletting, garages, etc., all for 200/250 volts A.C. mains, 5 amp. load, 19/- each; 10 amps, 22/6; 20 amps, 27/-; 25 amps, 32/6; 40 amps, 38/6; 50 amps, 46/6; and 100 amps, 57/6 each, all carriage paid.

6 or 12 VOLT RECTIFIERS at 4 amps output, complete with suitable transformer, 200/230 volts input, 45/- each, post 1/6.

METAL RECTIFIERS, suitable for 6/12/24 volts at 10 amps charging with the correct transformer, complete with TX 97/6 each, or Rectifier only 35/- each.

1,000 WATT AUTO WOUND VOLTAGE CHANGER TRANSFORMER tapped 0/110/200/230/250 volts £5/15/- each, carriage 4/6.

EX-W.D. U.S.A. HAND GENERATORS, less winding handle, output 425 volts at 110 m/a., at 63 v., 2 1/2 amps, complete with smoothing, 30/- each, carriage 2/6.

ROTARY TYPE RESISTANCES, stud 5/8m type 10 ohms 3 amps, 17/6 each. (Other types in stock, please ask for quotation.)

MAINS TRANSFORMERS (NEW), suitable for spot welding, input 200/250 volts, in steps of 10 volts, output suitably tapped for a combination of either 2/4/6/8/10 or 12 volts 50/70 amps, 95/- each, carr. 7/6.

MAINS TRANSFORMERS (NEW), 200/250 volts input in steps of 10 volts, output 0, 6, 12, 24 volts 6 amps, 42/6 each, post 1/6. Another as above but 10-12 amps, 55/- each, post 1/6; another, as above, but 25/30 amps, 75/- each, carriage 3/6; another, input as above, output 0/18/30/36 volts 6 amps, 47/6 each, post 1/6.

MAINS TRANSFORMERS (NEW), input 200/250 volts in steps of 10 volts, output 350/0/350 volts, 180 m/amps, 4 volts 4 amps, 5 volts 3 amps, 6.3 volts 4 amps, 45/- each, post 1/6; another 350/0/350 volts 180 m/amps, 6.3 volts 8 amps, 0/4/5 volts 4 amps, 45/- each, post 1/6; another 500/0/500 volts 150 amps, 4 volts 4 amps C.T., 6.3 volts 4 amps, C.T., 5 volts 3 amps, 47/6 each, post 1/6; another 425/0/425 volts 160 m/amps, 6.3 volts 4 amps, C.T. twice 5 volts 3 amps, 47/6 each, post 1/6.

TRANSFORMERS SPECIALLY MADE TO ORDER, delivery 72 hours from date of order. Please let us quote you.

MAINS TRANSFORMERS, 200/250 volts input, output a combination of 6, 12, 18, 24, 30, and 36 volts at 6 amps, 45/- each, post 1/6.

METERS, Moving Coil, 0 to 14 amps, 18/6 each. Ditto, Moving Iron, suitable for A.C. 0 to 30 amps, 25/- each. Another moving coil, 100 to 250 volts. D.C., 35/- each, all 4in. scale (Others in stock, please state your requirements.)

12/24 VOLT RECTIFIERS at 4 amps, with suitable Mains Transformer, 200/230 volts input, 55/- each, except 12/24 volts.

MAINS TRANSFORMERS, input 180/250 volts, output 435/0/435 volts, 250 m/amps, 6.3 volts 10 amps, 6.3 volts 8 amps, 6.3 volts 8 amps, 5 volts 6 amps, 65/- each; another, input as above, output 4,000 volts 2 1/2 m/amps, 4 volts 1 amp, 2 volts 2 amps, 45/- each.

SMOOTHING CHOKES, 4 henries, 250 m/amps, D.C. resistance 120 ohms, 12/6 each.

CONDENSERS, 0.1 mfd., 6,000 volts working, 6/6 each.

LARGE STUD TYPE DIMMER RESISTANCES, 10 ohms, 9/18 amps, 32 studs, 35/- each.

3 KILOWATTS DOUBLE-WOUND VOLTAGE CHANGER TRANSFORMERS, 110/230 volts or vice-versa, as new, weight approx. 100 lbs., £12/10/- each, carriage forward.

MAINS TRANSFORMERS, 200-250 volts input, output 400/0/400 volts, 280 m/amps, 6.3 v. 8 a., 2 v. 3 a., 5 v. 3 a., 4 v. 2 a., 4 v. 2 a., the last two heaters insulated at 8,000 volts, 85/- each; another 200/230 volts input, output tapped 0, 9, 18 volts at 4 amps, 25/- each, post 1/6.

D.C. MOTORS, 230 volts, 3 h.p., 3,000 r.p.m., in good condition, £3/5/- each; ditto Fan Motors, 230 volts D.C., 20/- each; 110 volts D.C., 17/6 each.

MAINS TRANSFORMERS, input 200/250 volts, output 45/50 volts, 70 amps, suitable for arc welding, £15 each; another 70 volts, 50 amps, £15 each.

Making a Potato Peeler

An Easily-made Appliance for Domestic Use

By G. F. Payne

THE construction of the small potato peeler described in the following notes is quite straightforward. The appliance is actuated by a water turbine of simple design, and the timber used is taken from two orange boxes, obtainable cheaply from most greengrocers. The boxes are taken apart and five of the six 12in. by 12in. by 3/4in. pieces planed up to a thickness of 5/8in. From these a bottomless box is made by dovetailing and gluing together. The lid is detachable and has a rim of 5/8in. square strip, to fit into the top of the box, and a 2in. by 5/8in. disc glued and nailed centrally (Fig. 1). The piece of perforated zinc is bent to form a cylinder 9in. by 10 3/4in. dia. and the joint

are then cut in the bottom edge of the wooden casing, about two on each side. The inside of the rotor and the top side of the zinc cylinder are coated with Pyruma putty fire cement 3/8in. in thickness on which are formed small square pointed teeth, using the block of wood cut as shown in Fig. 4, which is pressed into the soft putty all round. The cement is then allowed to harden naturally. All the woodwork is given several coats of hard gloss paint, inside and out.

The Turbine Wheel

The turbine wheel is made up from the two 1/4in.-thick wooden discs with a central 3in. by 3in. disc and the 12 3/4in. by 3/4in. by 1/4in. vanes glued and nailed between them

are then cut in the bottom edge of the wooden casing, about two on each side.

The inside of the rotor and the top side of the zinc cylinder are coated with Pyruma putty fire cement 3/8in. in thickness on which are formed small square pointed teeth, using the block of wood cut as shown in Fig. 4, which is pressed into the soft putty all round. The cement is then allowed to harden naturally.

All the woodwork is given several coats of hard gloss paint, inside and out.

Operation

In use, the peeler is placed in the sink and connected to the cold water tap by a short length of hose. A few potatoes at a time

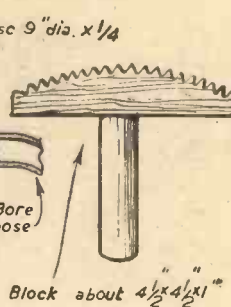
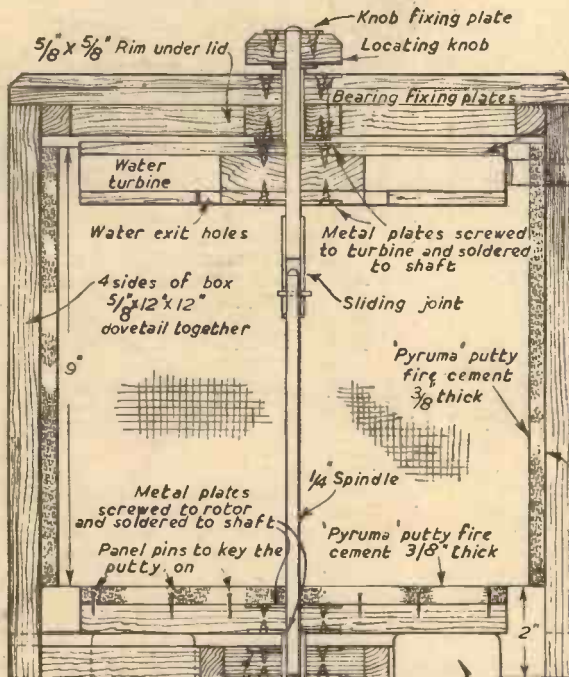

Fig. 4. — (Above) Wooden tool for forming the rough surface on the cement lining.

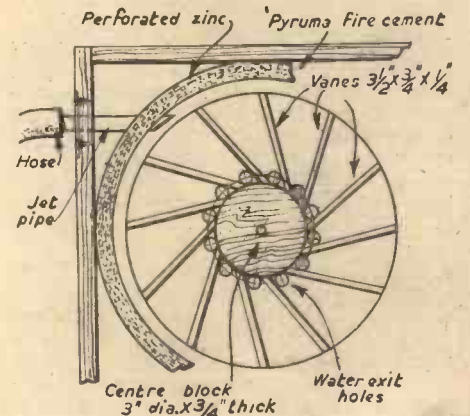

Fig. 3.—The turbine wheel, showing part of the casing, and position of jet pipe.

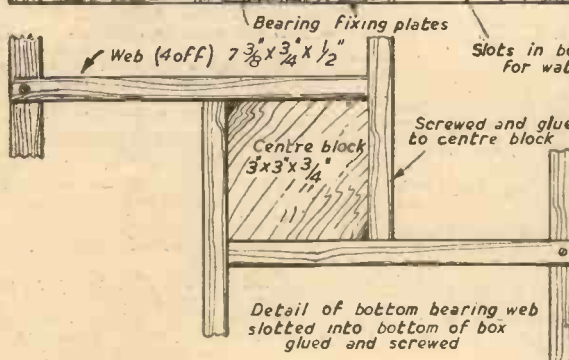

Fig. 2.—Details of the bottom supporting framework, showing the centre bearing block.

are prepared, being placed in the cylinder on top of the rotor and the lid replaced, using the knob to locate the two spindles, and the tap turned on full force. Provided there is a good pressure in the water supply the tur-

List of Materials Required

- 2 orange boxes
- 1 tin of Pyruma fire cement.
- 6in. of 1/4in. bore steel tube.
- 3in. of 1/4in. outside diam. tube.
- 4 1/4in. No. 4 steel wood screws.
- Length of 1/4in. rubber hose.
- 1 sheet of perforated zinc, 34in. x 9in.
- 14in. of 1/4in. brass rod.
- Piece of brass sheet 10in. x 4in.
- 30 1/2in. brass wood screws.
- 8 1in. No. 4 steel wood screws.
- Paint and panel pins.
- 12 1/4in. brass wood screws.

bine and rotor attain quite a high speed, and the water coming from the turbine rim and through the holes in the centre wash the rasped-off peel past the rotor and out at the bottom slots.

soldered. The cylinder is then screwed into the box 2in. from the bottom edge. The bottom bearing web is then made up and the steel bearing tube fixed and held by the two circular brass plates soldered to it and screwed to the centre block (Fig. 2). All holes for bearings and spindles are drilled slightly larger than required, as accurately as possible. The bearing or spindle is then fixed by one of the plates, trued up and finally fixed by the other plate. The web is then slotted into the bottom of the box, and glued and screwed.

(using panel pins), the bottom disc having holes drilled through it between the roots of each vane for water to pass through (Fig. 3). The turbine is then fixed to the top spindle which is 5in. long and has a piece of tube, with a slot to engage the pin on the rotor spindle, soldered to the lower end. The spindle is then passed up through the bearing in the lid (fixed and trued as before) and a small knob fixed on top. The jet pipe is fixed in place as shown. It passes through the side of the box and the zinc cylinder and is fixed by a plate screwed to the box. The water exit slots

THE MODEL AEROPLANE HANDBOOK

An Important New Work

By F. J. CAMM

312 Pages, 303 Illustrations, 12/6, by post 13/-

Construction and Principles of All Types

Published by

GEO. NEWNES LTD., TOWER HOUSE
SOUTHAMPTON STREET, STRAND
LONDON, W.C.2

LETTERS TO THE EDITOR

The Editor does not necessarily agree with the views of his correspondents.

Perpetual Motion

SIR,—I was very surprised to read in your September issue that your correspondent, C. V. Thompson, has never seen a clearly defined description of perpetual motion.

If he will refer to a well-known encyclopædia he will find under perpetual motion a very lucid explanation by Professor E. N. da C. Andrade of what constitutes perpetual motion, and why it is considered not to be possible.

He will also find that phenomena such as rivers, tides, and the clock he mentions all depend for their motion on an external source of energy and therefore do not constitute perpetual motion.

It is interesting that this letter should have appeared in the very issue next after your correspondent Frank W. Cousins had suggested that those wishing to voice an opinion on a subject would be well advised to first consult readily available sources of information on the matter in question before putting their opinions forward.—A. A. TYLER (Colchester).

Conservation of Energy : Inter-space Travel

SIR,—Regarding the query on the conservation of energy, by E. T. Bailey, the question is one of mechanics. The magnet in lifting each block does, as is stated, 1lb. inch of work. In the act of stripping the block from the magnet then 1lb. inch of work is done against the field. The algebraic sum of the total work done is zero. Hence, because no work is done no law can be contravened. The amount of power consumed in energising the magnet is quite irrelevant to the problem. Your correspondent might like to compare the case of dropping a stone on to the ground and picking it up again to the same height. Here gravity is acting similarly to the magnet and in this case also the total work done is zero. Carrying the analogy a little further, it would appear from your correspondent's argument that the gravitational field of the earth could be neutralised by dropping a sufficient number of objects on to its surface. This statement is clearly inadmissible. Similarly, so is your correspondent's problem.

Your other correspondent, W. J. Land, in his query on inter-space travel, is under the impression that heat cannot travel through a vacuum. It is well known that heat can travel in three ways, namely, by conductor, convection and radiation. If your correspondent could place a thermometer in the vacuum space of a vacuum flask, then on putting hot water into the flask he would find that the reading of the thermometer would increase, showing that heat can travel in a vacuum and does so by radiation. The sun's heat reaches the earth in this manner. Similarly, the glass bulb of an electric lamp is heated by radiation from the filament. The earth has had the sun's heat pouring on to it for about 3,000 million years, and it is still not red hot. It keeps cool by radiation. So would a space ship.

Meteors first appear at about a height of 80 miles and disappear at a height of about 50 miles. If they were red hot due to the

sun's heat they would be visible at a much greater height. See "General Astronomy," by Sir H. Spencer Jones, p. 267.—S. R. MORGAN (Cardiff).

A Model Schooner

SIR,—Having recently completed the twin-masted schooner in your book "Model Boat Building" I though other readers would be interested to see the result. It is of teak, sycamore mahogany and pine



Mr. H. Copey's model schooner.

construction, and is the first boat I have ever attempted. It is home-made throughout and its performance is excellent.—H. COPEY (Morley, Yorks).

Einstein's Theory

SIR,—Mr. Carr will, I am sure, be quite content to leave Michelson and Morley alone at last, since Mr. F. O. Brownson has gratuitously given him his assurance that they were not such fools after all.

Mr. Brownson, however, raises much more important matters and I would appreciate a little space to discuss them.

On the matter of the *aetheric cloud*. It is amusing to note that Mr. Brownson regards this as a *private theory*, when Michelson himself suggested that the earth dragged along the aether in its neighbourhood. This theory is not tenable, however, and I think I am right in saying it was Lord Kelvin who showed this to be a fallacy when he tested a ray of light for deflection in passing close to the periphery of a rapidly rotating wheel.

It should be made very clear that the result of the Michelson-Morley experiment is *not* explained by Einstein's Theory—it is the main postulate upon which his theory is based. There is, moreover, no need to explain the result of the Michelson-Morley experiment since it did not contradict Newtonian mechanics or Maxwell's theory of light. It

showed the concept of the mechanical aether to be invalid.

The aether is a British invention and, as Salisbury said, simply the nominative of the verb "to undulate." It was conceived as a ubiquitous blanchmange designed initially to carry light about from one place to another and graced with the delightful name—luminiferous aether.

I do not think the greatest minds have rejected the aether as Brownson suggests; they realise to talk of it has no meaning. (See article, "Ether," Enc. Britt., 14th Ed., by Sir Oliver Lodge.)

I do deprecate the idea put forward by Brownson that if the greatest minds gave us—the numskulls—a satisfactory explanation of how horsepower could be transmitted across space, we would be impressed with them—the greatest minds. It is, *ipso facto*, difficult and seldom worth while impressing numskulls and the problems are in this case complex, obtuse and intractable—possibly insoluble. Where in such a majestic concept as the structure of the universe is there room for cheap jibes at the workers at the frontiers of knowledge? It is possible now, in 1953, to give an explanation for the generation of energy in the stars and its transmission across interstellar space. It means dealing with nuclear physics, quantum mechanics, relativity and higher mathematics. These subjects are notoriously difficult and few are able or willing to follow completely.

It is, to use an apposite analogy, like climbing Everest mentally. For anyone who finds it difficult to scale the foothills, it is no use standing below the base camp and poking fun at the summit team for not being articulate in recounting the scenery from the top.

May I close with a few references worthy of consideration:

"Aether," Enc. Brit. (11th edition).
"A History of the Theories of Aether and Electricity." Sir Edmund Whittaker, F.R.S. (Nelson, 32s. 6d.)

"Ghost of the Aether." L. Rosenfeld. ("Manchester Guardian Weekly," Jan. 31st, 1952, p. 13.)

"Structure of the Universe." G. J. Whitrow. (Hutchinson, 1950, 7s. 6d.)

FRANK W. COUSINS (Greenford).

[Correspondence now closed.—ED.]

Anemometer Dial Graduations

SIR,—In the May, 1953, issue of PRACTICAL MECHANICS there is a description of a simple anemometer. After making calculations with the dimensions given, I find that they differ and make the graduations on the dial incorrect.

The overall diameter of rods and cups = 24in.

Circumference of circle described = $17d = 3.1412 \times 24 = 75.39in.$

Ratio of worm and worm wheel is as 56 : 1
∴ in 56 revs. of cups and arms, the distances described = $56 \times 75.39in. =$

$4221.8in. = 352ft. = \frac{1}{15}$ of a mile (approx.).

The dial is graduated into 20 equal parts and numbered $\frac{1}{100}, \frac{2}{100}$ up to $\frac{20}{100}$. Now suppose

the dial moves from 0 to $\frac{10}{100}$ in 1 minute, this

will mean a speed of $\frac{1}{30}$ of a mile in 1 minute

or 2 miles per hour. Or if the dial moves four turns in 1 minute this is $\frac{4}{15}$ of a mile per

minute, or 16 miles per hour. Each division on

the dial = $\frac{1}{20} \times \frac{1}{15} = \frac{1}{300}$ of a mile. If my calculations are correct, readers should alter the

dials made, or divide the results in miles per hour by three.—W. J. WOOLCOTT (Hull).

READERS' SALES AND WANTS

The pre-paid charge for small advertisements is 6d. per word, with box number 1/6 extra (minimum order 6/-). Advertisements, together with remittance, should be sent to the Advertisement Director, PRACTICAL MECHANICS, Tower House, Southampton Street, London, W.C.2, for insertion in the next available issue.

SITUATIONS VACANT

The engagement of persons answering these advertisements must be made through a Local Office of the Ministry of Labour or a scheduled Employment Agency if the applicant is a man aged 18-54 inclusive or a woman aged 18-59 inclusive unless he or she, or the employment, is exempt from the provisions of the Notification of Vacancies Order 1952.

METHODS PROCESS PLANNING ENGINEERS required by a large light engineering company on the south coast engaged on batch production work; sound general knowledge; good opportunity for right man. Applications will be treated confidentially. Staff pension scheme in operation. Box No. 111, c/o PRACTICAL MECHANICS.

FOR SALE

TRANSFORMERS DESIGNED and supplied for all requirements, Trains, Welders, Television, etc. Write or phone your requirements to F. W. Whitworth, A.M.Brit.I.R.E., Model Dept., Express Winding Co., 333, London Road, Mitcham. (MIT. 2128.)

TRANSFORMERS, Rectifiers, Volt and Ammeters, Controllers, Cut-outs, Battery Chargers, Power Units; lists; s.a.e. Harry Gilpin, Manufacturer, Portobello Works, Walton-on-Naze, Essex.

PERSPEX for all purposes, clear or coloured, dials, discs, engraving. Denny, 15, Netherwood Road, W.14. (SHE. 1426, 5152.)

NUTS, BOLTS, SCREWS, Rivets, Washers and hundreds of other items for model engineers and handymen. Send now for free list. Whiston, New Mills, Stockport.

COMPRESSOR EQUIPMENT, Miscellaneous Items; catalogue, 11d. Pryce, 157, Malden Road, Cheam.

COMPRESSORS for sale, 3 CFM, 180lbs. sq. in., on metal base, with driving wheel and receiver, price £3; 1/2 h.p. Heavy Duty Motors, price £3; carriage forward. Wheelhouse, 1, The Grove, Isleworth. (Phone: Hounslow 7558.)

HACKSAW BLADES, genuine surplus by leading Sheffield manufacturer; 12 Blades, 10in. and 12in., 3/3; 24 blades, 6/-, post paid. Sawyers Ltd., 115, St. Sepulchre Gate, Doncaster.

"PICADOR" ROTOSAW Portable circular saw attachment for your electric drill fitted with 4in. circular saw blade, adjustable fence to cut up to 1in. in depth, ideal for wood, plastic, or soft metals; 33/-, each, post paid. Lambs-wool polishing Bonnets, 5in., 4/3 each; Rubber Backing Discs, 5in., complete with key, 4/6 each; Abrasive Discs, 5in., 6 assorted grades, 2/-, Send 2jd. for lists of Saw spindles, Vee Pulleys and Belts. Plummer Blocks, etc. Sawyers, Ltd., St. Sepulchre Gate, Doncaster.

CIRCULAR SAW BLADES, superior quality, Sheffield made, 4in. 8/6, 6in. 13/6, 8in. 18/9, 10in. 25/6, 12in. 31/6; all post paid. Please state size of bore and teeth per inch. Sawyers Ltd., 115, St. Sepulchre Gate, Doncaster.

TYLER Spiral Hacksaw Blades cut in any direction at conventional hacksaw speed without turning the work. 10in. Hacksaw Blades 4d. each from leading tool dealers. Write to Spiral Saws, Ltd., Trading Estate, Slough, for details.

HOUSE SERVICE METERS, credit and prepayment; available from stock. Universal Electrical, 221, City Road, London, E.C.1.

LATEX FOAM UPHOLSTERY, 6ft. x 2ft. x 4in., covered, £5/15/-; carr. and 5/-; 2ft. x 1ft. 6in. x 4in. £1/10/-; c. and p., 2/-; 32in. x 16in. x 1 1/2in., 14/-; B. & M. (Latex) Sales, 16, Hamm Moor Lane, Weybridge, Surrey. (Weybridge 3311.)

ANTI-RADAR STRIP DISPENSER UNITS. These comprise two 1/20th h.p. 24v. shunt wound motors, with train of gears, both 25 and 50 to 1 reduction. The unit is mounted in an aluminium chassis and consists of over 100 gears, pinion shafts, etc., of the Meccano pattern, with variable speed switch and indicator light, bag of spares, and electrical diagram. These are all new and in original waterproof packages. They are something entirely new and never been offered before. Price 30/- each, carr. paid. H. MIDDLETON, 639, Abbeydale Road, Sheffield, 7.

SYNCHRONOUS CLOCK MOTORS with gear wheels attached, 230v., A.C. 5/Ph 50c., 12/6 each, plus 1/- postage. Universal Electrical, 217, City Road, London, E.C.1.

IN TWO HOURS you can sew an Emello Electric Cord to your own blanket; no connections to make, you just have to sew; extremely efficient, safe and guaranteed 2 years; 75 watt warms 45in. x 39in., 28/-; 100 watt, 49in. x 47in., 35/-; post paid. Emello (London) Ltd., Kempshott, Basingstoke.

EX-R.A.F. "Constant Speed Units" assembly of medium sized gears, ball-races, etc., in alum. casing, weight 9lbs., 7/6; post 2/-; ex-equipment screws, nuts, washers, mostly 4 BA, 2/6 per lb.; post 1/-; 6lbs. and over post paid. The Radio Services, Lr. Bullingham, Hereford.

AIR PRESSURE TUBING, 1/4in. bore, 10yds., 12/6; 1/8in. Rubber Tubing, 1/4in. bore, 100ft., 15/-; Plastic Asbestos Compound, Shell-Mex make, 14lb. block 8/6, cwt. 50/-; Cartons, once used, 12in. x 8in. x 9in., 100 lots 6d., 1,000 lots 4d. each; Black-lead Pencils, 24/- gross; Perforated Metal Sheets, 35in. x 24in., 5/- each; Cellulose Paint, stone, green, blue, brown, 5-gallon drums, 50/-, finest quality; Time Clock signature type, £15; airfield approach 5-Runway Light, £8, a fraction of its cost; Cylinders of Bowden brake wire, 10/-; Office Binders, ring type, 14in. x 10in., 3/9; round Asbestos Discs, 6in. x 1/4in., 3/6 dozen. Batley & Co., Stockport.

PLATED NUTS, Screws, Washers, Bolts, Soldering Tags, Hank bushes, Self-tapping Screws, Grub-screws, Socket-screws, Wood-screws; large quantities or gross cartons. List sent post free. Sinden Components Ltd., Dept. E., 117, Churchfield Road, Acton, W.3. (ACORN 8126.)

ELECTRIC BLANKET; make your own in 5 minutes; we supply the interior element complete, 6ft. long, 2ft. 6in. wide, and 9ft. of flex attached; tested and guaranteed; 35/-, Dept. E.L., Brace, Dairy Green, Thaxted, Essex.

JET POWER for boat, bike, etc.; no special metal; simplest engine to build; few or no moving parts. Details and drawings of model set, engine, large engine, small helicopters, 3/6 each. R. MARTIN, 12, Cromwell Road, Portsmouth.

PLANS! Easy to make. 6in. wood-lathe, 8in. sawbench, 3/6 each, 6/6 both. From Abud Products (Plans). 64, Anley Road, Birchencliffe, Huddersfield.

POWERFUL 24-VOLT GEARED MOTORS, series wound, will run on A.C. or D.C.; 24-volt intermittent rating; final speed approx. 75 r.p.m.; weight 3 1/2lb., size 4 1/2in. x 2 1/2in., approx. 1/2 h.p.; light, powerful and compact; ideal unit for food-mixers, hedge-cutter, etc. Makers, Dumore Co., U.S.A.; spur and gummetal worm-wheel totally enclosed; price £1/10/-, post paid. H. Middleton, 639, Abbeydale Road, Sheffield, 7.

FASCINATING Steel Tracing Machines for copying and enlarging from newspaper and magazine drawing, sketches; interesting; 5/-, post free. CLAYTON, 16, Westminster Rd., Bradford, 3, Yorks.

ELECTRIC WELDING PLANT. Large selection of new, surplus and secondhand plant. Arc Welders from £20; Portable Spot Gun Welders, £28; Carbon Brazing and Welding Sets (mainly operated). £5/15/- Send stamp for catalogue with prices. Harmsworth, Townley & Co., 1 Brook Road, Manchester, 14. (RUSHOLME 3003.)

BUILD YOUR OWN Kitchen Cabinets and Kitchen Furniture. It's easy with a "Coitycraft" Cabinet Kit in which all parts are machined for easy assembly at home. Write for leaflet. Coity Crafts, RA/201 Works, Bridgend, Glamorgan.

MAKE YOUR OWN RANGE-FINDER, instructions and all material, 11/-, Elgin, 12 Margravine Gardens, Barons Court, London, W.6.

HANDICRAFTS

MUSICAL MECHANISMS. Swiss made, for fitting in cigarette boxes etc., 22/8 each. Send 6d. for complete list of handicraft materials. Metwood Accessories, 65, Church Street, Wolverton, Bucks.

ELECTRICAL

BARGAINS FOR ELECTRICIANS. Brand new Cables in 25-100yd. lengths; T.R.S. twin, 1/044, 42/-; 2/023, 60/-; 7/029, 95/-; 3/029 with earth, 72/6; 7 029 with earth, 117/6; P.V.C. twin, 1/044, 38/6; 3/029, 56/-; Transparent Flex, 14/36 twin, 17/6. All per 100yds.; carriage paid. Fully wired Ballast Units, 38/6; c.w.o.; request list. Jaylow Supplies Ltd., 93, Fairholt Road, London, N.16. (Tel.: STAMFORD Hill 4384.)

BROOKS 1/2 h.p. Motor, 230v., 50c., single-phase, 2,800 r.p.m., ball-bearing; ideal for driving wood-working machines; latest type, in maker's sealed box; brand new; £8/15/-; carr. paid. Blood, Arch Street, Rugeley, Staffs.

PHOTOGRAPHY

ENLARGER and Camera Bellows supplied; also fitted. Beers, St. Cuthbert's Road, Derby.

MODEL DEALERS

SUPER SHIP FITTINGS; Bollards, four types Davits, etc.; list 3d.; only from Glassford's, 89, Cambridge Street, Glasgow.

LONDON. Robson's Hackney's Model Shop, 149-151, Morning Lane, E.9. (Tel.: AMHERST 2989.)

HOBBIES LTD. have over 50 years' experience of catering for the needs of modellers, handymen and home craftsmen. Branches at 78a, New Oxford Street, London, and in Birmingham, Glasgow, Manchester, Leeds, Sheffield, Hull, Southampton and Bristol. Head Office, Dereham, Norfolk.

SHIPS IN BOTTLES. The constructional kit that tells you how to make them; build for pleasure or for profits; kits 6/- ea. from Hobbies Ltd., and model shops, Cooper-Craft Ltd., The Bridewell, Norwich.

HOBBIES

DOLLS HOUSE FITTINGS and Papers; Wooden and Metal Toy Wheels (trade supplied); illustrated brochure; s.a.e. Jasons, 135, Nags Head Road, Enfield, Middlesex.

TOY CASTING MOULDS, soldiers, sailors, airmen, animals, etc. Rubber Moulding Compound, 8/6 per lb. Moulds for Plasticwork, plaques, ornaments and Corcaon souvenirs. Moulds from 3/6 each; catalogue 9d.; s.a.e. for list. F. W. Nuthall, 69, St. Marks Road, Hanwell, London, W.7.

MAKE MONEY making Wooden Toys; we supply the parts all ready to assemble and paint. List free. Elf Manufacturing Co., Dept. "P", Mitton Mill, Stourport-on-Severn.

CASTING MOULDS for lead soldiers, animals, etc. Complete illustrated catalogue 6d. Sample mould 6/-. G. F. Rhead, Hartest, Suffolk.

GROW Valuable Living Miniature Trees; wonderfully decorative; terrific new hobby; send s.a.e. for details: Miniature Trees, Dept., 90, Room Two, 3, Bloomsbury Street, London, W.C.1.

RADIO

CAN YOU SOLDER? That's all you need to make a really good Radio or Tape-recorder from guaranteed Osrom components; send 5d. (stamps) to-day for free circuits and lists. Dept. P.M.C.I., Osrom Radio Products Ltd., Borough Hill, Croydon, Surrey (Croydon 5148-9).

10,000 from 2/- Master-Contactors, 10/-; Electric Toys, 15/-; Fractional A.C. Motors, 12/6; Tool Boxes, 1/6; P.M. Cabinet Speakers, 29/6; Volume Controls, 1/-; Moving Coil Speaker Chassis, 13/6; and many other snips. S.A.E. for list. Chorlmet Radio, 480, Oldham Rd., Manchester, 10.

CYCLING

DON'T throw away your old Torch and Cycle Batteries, recharge them again and again with the G and L Charger. Operates from any car battery or battery charger (static voltage). Standard size 8/6; double size to charge both your own and friends batteries, 12/6, post free. Gardner & Lane, Old Hill, Chislehurst, Kent.

DRAWING SERVICE

DRAWING OFFICE CAPACITY AVAILABLE. Mechanisms designed detailed from sketches. Confidential. Box No. 109, c/o PRACTICAL MECHANICS.

WATCHMAKERS

WATCH CASES, Movements, Dials, Wheels, Pinions; return post service. Gleave, Albemarle Way, E.C.1. Write for list No. 7/53.

INTERCHANGEABLE Watch Parts: Staffs, 1/-; Stems, 8d.; Buttons, 5d.; other material quoted for; make and cal. no. or movement required. Every description repairs undertaken. J. H. Young & Son, Wholesalers, 133, London Road, Chippenham, Wilts.

ASSORTED Pocket Watch Movements, 6 for 10/-; Assorted Wristlet Watches, 10 for 42/6; Jewelled Wristlet Movements, 10 for 40/-. Loader Bros., 36, Milestone Road, Carterton, Oxford.

WE CAN HELP YOU. Every member of our staff is a skilled watchmaker and as such he understands your difficulties and trials. Why not send for our latest material and tool lists gratis and post free? Interchangeable Balance Staffs, Winding Stems, Buttons, Hands, complete Balance Assemblies, Escape Wheels, Pallets, in fact, everything the watchmaker requires. No inquiry too trivial, we are here for your benefit. H. S. Walsh, 28, Anerley Station Road, London, S.E.20.

MISCELLANEOUS

BUILD YOUR OWN REFRIGERATOR, all components available at reasonable prices. Frigidaire flowing cold units, £5; small units, Kelvinator, etc., £4; 1/2 h.p. heavy duty Motors, £3; Chrome Cabinet fittings, new, £1; money back guarantee, s.a.e. for list and schematic diagram. Wheelhouse, 1, The Grove, Isleworth, Middx. (Phone: Hounslow 7558.)

EXPERIMENTERS and Model Makers. Send for my list of useful Equipment, Tools, Materials and Scientific items at clearance prices. Box No. 110, c/o PRACTICAL MECHANICS.

90 COPIES PRACTICAL MECHANICS, 1944-1952, excellent condition, 25/-, Sharp, Greengates, Lyme Regis, Dorset.

PRACTICAL MECHANICS, February, 1949 to August, 1953, less 2 ('49), 4 ('50), 1 ('51). Offers. Box 108, c/o PRACTICAL MECHANICS.

WANTED

BACK Nos. P.M., April, May, June, 1951. 15, Beach Road, Clacton.

WOODWORKING

MAHOAGNY PLYWOOD, new, any parcel £1 delivered c.w.o.: 6 at 1 1/2 x 60 x 1/4in., 7 at 42 x 12 x 1/4in., 12 at 14 x 26 x 1/4in., 14 at 14 x 23 x 1/4in., 17 at 14 x 20 x 1/4in., 20 at 14 x 17 x 1/4in., 14 at 12 x 27 x 1/4in., 6 at 14 x 23 x 3/16in., 20 at 6 x 23 x 1/4in., 20 at 60 x 4 x 1/4in. Birch, 30 at 5 1/2 x 78 x 4mm. Small mixed sizes, £1 1/2 cwt. Following one side slightly glue stained: 6 at 25 x 23 x 3/16in., 7 at 23 x 23 x 3/16in., 10 at 20 x 20 x 3/16in. M. Leader (1920), Gosford St., Middlesbrough.

MAHOAGNY PLYWOOD, resin bonded, all £1 parcels; carriage paid; cash with order; satisfaction or money refunded. 7 Pc., 23in. x 23in. x 3/16in.; 60 Pc., 78in. x 23in. x 3/16in.; 16 Pc., 20 1/2in. x 14 1/2in. x 1/4in.; 8 Pc., 78in. x 3/16in.; 22 Pc., 17 1/2in. x 14 1/2in. x 1/4in.; 6 Pc., 23 1/2in. x 14 1/2in. x 1/4in. Trade enquiries invited. Dickens, 50, Mandale Road, Thornaby-on-Tees.

WOODWORKING MACHINES, Saw Benches, complete, 7in. £4/15/-; 8in. £5/10/-; Lathes, £7/10/-; Bowl Turning Heads, £7/10/-; Combination Lathes, £10/10/-; Planers, Saw Spindles, Motors, etc. 4d. stamp for illustrated booklet; n.p. available. James Inns (Engineers), Dept. P., Sherwood, Nottingham.

MYBLO GIN SAWBENCHES, rise and fall spindle, 12in. x 9in. table, ripp and mitre fences, V-drive, £6/15/-; from your tool dealers or direct from makers; P. Blood & Co., Arch Street, Rugeley, Staffs.

FOR HOME, OFFICE, WORKS AND LABORATORY USE

THE "DERMIC" OILER



Mark III

4/11 Post Free

As supplied to Official Departments and Undertakings, Engineering and Aviation firms, etc.

Use a "DERMIC" Oiler for clean and accurate lubrication of models, clocks, watches, sewing machines, typewriters, movie cameras and projectors and any delicate instruments or mechanism. Can also be used for the clean and efficient application of soldering fluid. Packed in box with full instructions. Manufactured by

S. & B. PRODUCTIONS,
Orton Buildings, Portland Road,
South Norwood, London, S.E.25.
Phone: LIV 4943.

You Can Become a HANDICRAFTS INSTRUCTOR

EXPERIENCE NOT ESSENTIAL

Men who enjoy making things in wood or metal can turn their hobby into a permanent and interesting Career! Short hours, long holidays, and security in a job you would really enjoy, can be yours if you become a Handicrafts Instructor. Let us send you details of the easiest and quickest way to get the necessary qualification.

We definitely Guarantee "NO PASS—NO FEE"

If you would like to know about our unique method of preparing you for one of these appointments, write today, and we will send you an informative 144-page Handbook—FREE and without obligation. Mark your letter "Handicrafts Instructor."

British Institute of Engineering Technology
591, Shakespeare House,
17/19, Stratford Pl., London, W.1 **BIET**

COMPRESSORS
Twin cylinder, ex-W.D. Ready for use. 12 cubic feet. Guaranteed. £12 10/-. Weight 65lb., professional type. Full details of this, other models and receivers on request.

SWITCH PANELS
with 16 toggle switches and terminal strip in metal case. 9/6.

COMPRESSION SPRINGS—Box of assorted, 50 for 3/-.
HEADPHONES—U.S.A. High type, new, boxed, with Flex and Plug. 8/6.

AIR VALVES—2-way and off positions. Gunmetal. Weight over 1lb. With nuts and fittings, 6/9.

BULBS—24 volt, M.E.S. tested, 37-doz. 300 other interesting items. List 14d.

ROGERS 13, NELSON STREET, SOUTHPORT

3" PORTASS P.D.5 £29.10.0
Less Counter Shaft.

S.S.C. LATHE
Dept. P.M. Charles Portass & Son, Buttermere Works, Sheffield, 8 Stamp please

WEBLEY AIR PISTOLS
Marvellously accurate for target practice.
No licence required to purchase for use on enclosed premises.
Write for Catalogue of AIR PISTOLS, AIR RIFLES and Accessories.
WEBLEY & SCOTT LTD.,
106, Weaman Street, Birmingham Eng.

WIRING ACCESSORIES
All goods are of a well-known manufacture and carry a money back guarantee. All cables are manufactured to the latest British Standard Specification. C.O.D. or C.W.O. All carriage paid.

CABLE TRS. Flat Twin 1.044 50/-; 3.029 68/-; 7.029 110/-. PVC sheathed Flat Twin 1.044 42/6; 3.029 62/6. All per 100 yds. Our PVC cables are suitable for interior or exterior use and may even be buried in concrete. All types and sizes of cables available in 25, 50 or 100 yd. lengths. Heavy cables out to desired length at no extra charge. Switches 1/8; 2 Way 2/-; Ceiling Roses 10d.; Lampholders 10d.; 3 Pin Sw. Sockets 5A 4/6; 15A 6/6. Send for price list of other accessories.

HUNT & CO.,
WEST STREET, EXETER.
Phone: Ereter 56637.

BUILD YOUR OWN BOAT FROM PREFABRICATED PARTS
Send 2/6d. for Illustrated Booklet containing details of all our kits and finished boats.

BELL WOODWORKING CO., LTD.,
Boat Builders, Aylestone Park, Leicester
Telephone 32480

H.A.C. SHORT WAVE EQUIPMENT
Noted for over 18 years for... S.W. Receivers and Kits of Quality.

Improved designs with Denco coils:
One-Valve Kit, Model "C" Price, 25/-
Two " " " "E" " " 50/-

All kits complete with all components, accessories, and full instructions. Before ordering call and inspect a demonstration receiver, or send stamped, addressed envelope for descriptive catalogue.

"H.A.C." SHORT-WAVE PRODUCTS
(Dept. 16), 11, Old Bond Street—London, W.1.

BRITINOL Soldering Outfits Solve All Soldering Problems!
(As reviewed in PRACTICAL MECHANICS May, 1953)

The "Popular" Outfit, as illustrated, Britinol Spirit Blow-lamp, Telescopic Soldering Iron, Paste and Cored Wire Solder, 10/3. The "Junior," as above, but without Soldering Iron. 9/6. All items sold separately. From Model Shops and Tool-Dealers.

BI-METALS (BRITINOL) LTD.,
St. Mary's Works, Bridge Road, London, N.9. S.A.E. for illustrated list.

IMPETUS Precision PLANERS
Circular safety type cutter-head High quality tempered steel knives. Tables mounted on machined inclined ways. Ground table-surfaces. Pencils adjustable to 45 degrees.

4 in. MODEL £9.10.0
Motorised, £18.10.0. 6 in. MODEL £28.10.0. Motorised £41.0.0. Send for Catalogues of other 'Impetus' Products.

JOHN P. M. S. STEEL, Dept. 90,
BINGLEY, YORKS.
Phone: BINGLEY 3514 (4 lines).

REFILL YOUR OWN BALL PEN
KOLOID REFILL KIT
POST FREE 3/6 PER OUTFIT
COMPLETE WITH ILLUSTRATED INSTRUCTIONS AND TOOL
Contains Ink for Blue, Violet, 12-15 Refills Red, Green.

G. H. HOLMES
(Dept. 5), 67, Brunswick Park Road, London, N.11.

RATCHET & REVOLUTION COUNTERS
Ask for Leaflet No. 18/1
Speed up to 6,000 r.p.m.
B. & F. CARTER & Co., Ltd., Bolton 5

The 'Adept' Bench Hand Shaper
Length of stroke of ram 3 1/4 in. No. 2 B.H. Shaper. 6 1/2 in. stroke. Price £18 17s. 6d. Also Power Driven—Extra Postage and packing 3/6 (U.K.). The 'Adept' 2 1/2 in. B.S.F. 4-Jaw Independent Chuck. Reversible Jaws, 38/6.

F. W. PORTASS, MACHINE TOOLS, LTD.
ADEPT WORKS, 55, MEADOW STREET, SHEFFIELD, 3.

SALUTE FLUORESCENT—the newest light source which is saving thousands of pounds every year in offices, factories and shops throughout the country!
Examine this simple case over a period of 1,000 hours' use:—

	150w. Bulb	40w. Fluor.
Light output (lumens)	1,970	2,000
Lamp Life (hrs.)	1,000	5,000
Lamp Cost	2/6	11/9
Cost of 1,000 hrs.	2/6	2/4
Cost of power/1,000 hrs. @ 2d. per unit ...	25/-	6/8
Total Cost per 1,000 hrs.	27/6	9/-

FOR FLUORESCENT CONTROL EQUIPMENT AT REASONABLE PRICES WRITE
DYNALITE ELECTRICAL (PM),
38, Stevedale Road, Welling, Kent.

Jubilee Famous in FOUR REIGNS

L. ROBINSON & CO. (GILLINGHAM) LTD.
London Chambers, GILLINGHAM, KENT, Phone 5292

BATTERY CHARGERS
Reliable, easily installed, economical Selector switch for 2, 6 and 12 volts 1 amp. In Black Crackle Steel Case with Ammeter, Mains-switch, fuses, etc. 200-250 volt A.C. Guaranteed. 82/6 post free, from manufacturers.

THAMES VALLEY PRODUCTS (P) "Orari," Eleanor Rd., Chalfont St. Peter, Bucks.

PORTASS 4 1/2" x 37" S.C. LATHE
Cast Iron Tray and Ped in 2 lengths.
Charles Portass & Son, Dept. P.M. Buttermere Works, Sheff. 8.

BUYING NEW EQUIPMENT?
First consult our new BUYER'S GUIDE
Post Free (returnable)

T. GARNER & SON LTD.,
Hand and Machine Tool Division,
6-8 Primrose Hill, BARNSELY.
Phone: 2908.

CHEMISTRY APPARATUS
Send 2d. stamp for COMPLETE PRICE LIST

Booklets:
"Experiments" 10/4.
"Formulae" 10/4.
"Home Chemistry" 2/3
Post Paid.

BECK (Scientific Dept. A)
80 HIGH STREET,
Stoke Newington, London, N.16

G.E.C. & B.T.H. GERMANIUM CRYSTAL DIODES
G.E.C. GLASS TYPE 1/16in. x 3/16in.
B.T.H. LATEST TYPE MOULDED IN THERMO-SETTING PLASTIC
Both Wire Ends for Easy Fixing.
4/6 each, postage 2/4d.
B.T.H. SILICON CRYSTAL VALVE
3/6 each, postage 2/4d.
Fixing Brackets 3d. extra.

Wiring instructions for a cheap, simple but high quality Crystal Set included with each Diode and Crystal Valve.

COPPER INSTRUMENT WIRE
ENAMELLED, TINNED, LITZ, COTTON AND SILK COVERED.
All gauges available.
B.A. SCREWS, NUTS, WASHERS, soldering tags, eyelets and rivets.
EBONITE AND BAKELITE PANELS, TUFNOL ROD, PAXOLIN TYPE COIL FORMERS AND TUBES.
ALL DIAMETERS.
Latest Radio Publications.
SEND STAMP FOR LISTS

CRYSTAL SET
INCORPORATING THE SILICON CRYSTAL VALVE
Adjustable Iron Cored Coil.
RECEPTION GUARANTEED
Polished wood cabinet, 15/-, post 1/-. A REAL CRYSTAL SET NOT A TOY
POST RADIO SUPPLIES
33 Bourne Gardens, London, E.4

HIGH GRADE SURPLUS ELECTRONIC COMPONENTS
HEAVY DUTY WIRE WOUND POTENTIOMETERS. Brand new in makers cartons. 6in. dia. 1,600 ohms 4 amp. with 3 in. skirted knob, 22/8. 4in. dia. 2,000 ohms 22 amp. with 3in. skirted knob, 15/-, p. & p. 1/6. **HEAVY DUTY I.T. TRANSFORMERS.** Prim. 230 volts. Sec. tapped 4-11 volts, 200 amps. £7.10.0 callers only. Prim. 200-240 volts. Sec. tapped 10-12 volts 16 amps. 29/6, carr. 2/-. Prim. 200-240 volts sec. 6.3 volts 15 amp., 19 6. p. & p. 1/6. **PARMEKO H.T. TRANSFORMERS** Prim. 100-250 volts sec. 1,300-0-1,300 volts 250 MA. Potted Type Brand New, 59/6, carr. 5/-. **P.A. RMEKO L.F. CHOKERS** 10 H. 250 MA. Potted Type Brand New, 15/-, p. & p. 2/-. All Inquiries Welcome.

J. HALLETT
19, Upper Richmond Road, London, S.W.15.

ELECTRIC MOTORS
Ideal for handyman or hobbyist

47/6 ONLY
37/6 if required with Chuck ONLY
or Grinding Wheel ONLY.
ORDER NOW.
Full Money Back Guarantee.
LUKELECTRIC LTD. (Dept. 7), Leigh-on-Sea, Essex.

THE SUPER ADEPT LATHE
1 1/2 in. centres, 6 in. between centres.

A good Range of Accessories is available.

BECK (Scientific Dept. A)
80 HIGH STREET,
Stoke Newington, London, N.16

Trade Notes

Sparks' Data Sheets

A CHASSIS section has now been added to the popular data sheet suppliers of Swanage. This makes it possible for those who obtain the data sheets to build the selected design on a ready-drilled chassis. It should be noted that, in addition to the supply of data sheets for various types of receiver, Messrs. Sparks can now also supply all of the components specified in the sheets. To the latter have now been added, by special arrangement with Messrs. Mullard, practical constructional details and layout, etc., for the circuits contained in the Mullard booklet, "The Amateur's Guide to Valve Selection." The charts are full size, printed in black and white, complete with the theoretical circuit, all component values and prices. Most of the prints measure 22in. by 15in., but many are larger than this. The prices of the majority are 3s. each, and lists of designs are available from Sparks' Data Sheets, 48A, High Street, Swanage, Dorset.

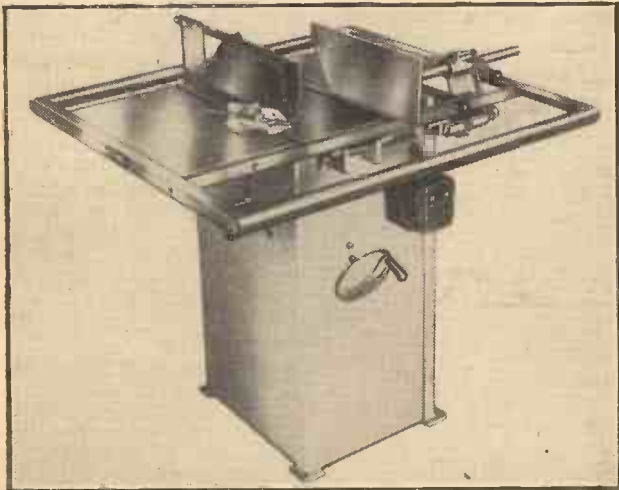

The new "Startrite" 11-in. saw bench.

"Atlas" Handicrafts Price List and Illustrated Supplement

FROM Messrs. Fred Aldous Ltd., we have received their "Atlas" Handicrafts 1953-54 price list and a very attractively illustrated supplement. Both of these booklets contain long and comprehensive price lists of designs, materials, tools and literature for an extremely wide range of handicrafts. Among those for which this firm supplies everything necessary are included: basketry, raffia work, bookbinding, tapestry making, feltwork, lampshade making, leatherwork and glove making, lino craft, marquetry, modelling, needlework and embroidery, pewterwork, plastics, rugmaking, artificial flower making and jewellery making. Special leaflets are also published with titles, "Lampshade craft," "Handicraft Jewellery," and "Modern Basketry." In many cases complete kits are supplied and instructions are also included. The price list includes a comprehensive list of books on handicraft subjects. All queries should be addressed to Fred Aldous, Ltd., 20-22, Withering Grove, Manchester, 4.

New "Startrite" 11in. Saw Bench

THIS latest "Startrite" product is designed to fill a need in the woodworking industry for a reasonably priced saw

bench with larger table working area and greater cutting depth. It will accurately rip 4½in. of hard timber—the table is 3ft. by 3ft. with 15in. of bench in front of blade at maximum cut. Introduction of feed and run-off rollers make for easy handling of heavy timber and panels. Suitable for ripping, mitring, grooving and shaping the saw is an ideal tool for joiners, builders, contractors, cabinet makers and the like.

The scientifically designed central table casting is accurately machined to provide mountings for saw spindle, fence and riving knife assemblies. This construction ensures accurate alignment throughout all working parts. A gap plate is provided for interchange of saw and cutters. The table is grooved either side of saw for mitring fence.

The accurately ground spindle runs in dust-sealed ball bearings. Mounted in a robust bracket casting the saw spindle is pivoted from the under-face of the table. The raising and lowering motion is by screwed shaft and large hand wheel conveniently located at front of saw.

Equipped with steel face plate the tilting rip fence is arranged for quick movement across the table. It is graduated for canting movement up to 45 deg.—tilt and traverse locking gear are controlled by ball handles. The mitre fence is graduated and arranged to swivel 60 deg. in either direction. Length gauge is supplied for repetition work.

The special safety blade guard is designed to cover the saw at all times, at any depth of cut. The riving knife is contoured to saw diameter. It is rigidly bolted on the saw spindle housing and rises and falls with the saw. The cabinet

is of heavy welded steel construction including an in-built sawdust chute and completely houses the entire spindle assembly and electric motor.

The 1½ h.p. squirrel cage protected type motor is mounted integral with the saw spindle assembly. The short centre dual vee-belt drive transmits ample and constant power to the saw. Motor is controlled by push button contactor starter with no-volt and overload release.

The cabinet and main castings are excellently finished with a durable polychromatic enamel, and all bright parts are plated.

The price is £69 10s. with 400/440v. 3-phase motor and £79 10s. with 230/240v. single phase motor. All queries should be addressed to the Startrite Engineering Co., Ltd., Waterside Works, Gads Hill, Gillingham, Kent.

A Rubber Football

A FOOTBALL made of rubber, identical in size and weight with the ball used in League matches, has been successfully produced, after two years' research work, by Dunlop's factory at Speke, Liverpool. The aim is to stem the rising cost of sport, and the new ball will sell at 25s., as against from £2 10s. to £5 5s. for a leather ball.

Research has been chiefly directed towards a compound matching as far as is possible

the characteristics of leather. This incorporates new ingredients requiring a special compounding technique, and the result is tough and comparatively non-stretching. The ball remains inflated for 14 days, and it can then by a simple connector be blown up with a bicycle pump.

Osborn Mushet Drill Pack

THE drill pack is not a new idea—nevertheless the new Osborn Pack has certain novel features which distinguishes it amongst its contemporaries. The pack contains 13 Mushet High Speed Steel Drills, sizes increasing in 1/64ths from 1/16in. to ½in.; these are held rigidly in position in polythene strips within the flat metal polished container.

Merely by opening the hinged covers, the 13 drills are automatically raised erect ready for use, sizes being clearly marked beside each drill, the case becoming a handsome drill stand for the workshop bench. When closed, the polished metal container has the appearance of a cigarette case, and will fit snugly into the pocket, the drills being held quite firmly in position. The main features of this new pack being its extreme compact-

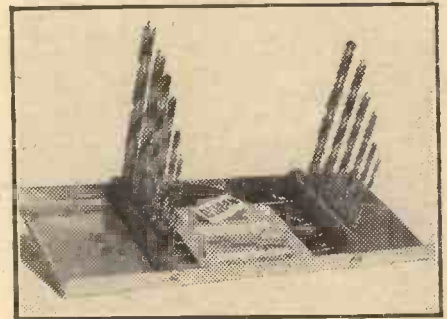

The Mushet drill pack.

ness, good appearance and the ease with which the fine quality drills are made available for use.

Mardrive Clutch Motors

THE D.I. type Mardrive clutch motor is a further advancement on the standard Mardrive clutch motor which has been produced for many years and has been designed to fulfil demands from users as the advantages of the clutch motors have become more widely appreciated.

The basic principle remains the same for providing a drive which can be rapidly started and stopped and at a greater rate and more frequently than can be achieved by direct switching of a plain motor.

The essential features of all Mardrive clutch motors are the continuous running rotor and flywheel assembly with which is engaged the combined clutch and pulley member for effecting the drive to the driven machine by means of the vee belts.

Engagement of the clutch is effected by actuation of the clutch operating lever which, in turn, when released allows the internal spring to engage upon the internal ball thrust-race and thus disengage the clutch faces at the same time engaging the outer face of the clutch plate with the brake lining carried on the rigidly mounted brake bracket.

Further details are obtainable from the manufacture and patentees, The Marine Engineering Co. (Stockport) Ltd., Bulkeley Street, Stockport.

REFRESHER COURSE IN MATHEMATICS

(4th Edition.)

By F. J. CAMM

8/6, by post 9/-

QUERIES and ENQUIRIES

A stamped, addressed envelope, a sixpenny, crossed postal order, and the query coupon from the current issue, which appears on the inside of back cover, must be enclosed with every letter containing a query. Every query and drawing which is sent must bear the name and address of the reader. Send your queries to the Editor, PRACTICAL MECHANICS, Geo. Newnes, Ltd., Tower House, Southampton Street, Strand, London, W.C.2.

Removing Tea Stains

WHAT would be a suitable material to use for cleaning tea stains from plastic cups and saucers? I have several gross of these.—E. W. Collins (Sussex).

TEA stains are notoriously difficult to remove. Theoretically, a solvent for tannin should be the answer, but this may be defeated through the tannin stains containing unknown organic dyes. We would suggest trying soda and water—this will not harm the cups; and also you might try in turn:

(a) Potassium permanganate solution (should this leave a yellow stain, this secondary stain can be removed by peroxide of hydrogen).

(b) Methylated spirit.

(c) Fehlings solution; this can be bought ready made in two solutions (a) and (b).

Solution (a) consists of 70 gms. copper sulphate to 1 litre water.

Solution (b) 346 gms. of crystallised rochelle salt are dissolved in half litre of hot water and 142 gms. sodium hydroxide in a similar volume of water. These two solutions are then poured into a litre bottle.

Equal volumes of (a) and (b) when mixed make Fehling's solution, which should be effective in removing tea stains.

"Back-projection Episcopes" as TV. Enlarger

COULD I adapt your "Back-projection Episcopes" as an enlarger for my TV., which has a screen of approx. 7½in. x 5½in.?

How much is the advocated Dallmeyer lens?—T. Baron (Yorks).

AS the screen of the usual television is curved, there is likely to be difficulty in obtaining a picture which is in sharp focus all over. Before embarking on the construction of the complete apparatus, it would be safest to make a simple preliminary test with the lens you intend to use. To do this, set up a white cardboard screen in front of the television and 43in. from it. Mount the lens on a large piece of thick cardboard or plywood and place it between the television and the screen. Move the lens until the best possible image is obtained on the temporary screen. The picture will be inverted, of course, but you will be able to judge for yourself if the quality is satisfactory.

To project a picture 7½in. by 5½in. the screen of the episcopes will need to be 22½in. by 16½in., and the opening below the screen will, of course, have to be enlarged. To accommodate the larger screen the height of the cabinet will have to be increased by 2½in. and the width by 5in. The distances between the lens, mirrors and screen must not be altered. Make sure that the distance between the centre of the screen and the centre of the opening is 15½in. as in the published diagram.

With the dimensions given a lens with a focal length of 8in. must be used. A lens of smaller aperture (higher number than *f.2.9*) could be used, but the picture would not be so bright. The Pentac costs between 4 and 6 guineas. No lighting would be required with the television screen in use.

Self-polishing Cloths

I AM interested in making metal, furniture and silver self-polishing cloths.

Can you tell me the various chemicals with which each type of cloth is impregnated, in which proportions to mix chemicals, and source of supply, if possible?—J. W. Ramsdale (Liverpool, 20).

SELF-polishing cloths can be impregnated with any of the mixtures given below by suspending the powders in a solution of soap, algin, methyl cellulose, etc., to which a small proportion of glycerine and salt

Readers are asked to note that we have discontinued our electrical query service. Replies that appear in these pages from time to time are old ones and are published as being of general interest. Will readers requiring information on other subjects please be as brief as possible with their enquiries.

have been added. The cloths are dipped two or three times at appropriate intervals.

Furniture:

- 4½ lbs. yellow carnauba wax.
- 6 lbs. bleached moutan wax.
- 7½ lbs. ceresine.
- 3½ gals. turps.
- 1 gal. white spirit.
- ¼ gal. oil of spike lavender.

THE P.M. BLUE-PRINT SERVICE

- 12FT. ALL-WOOD CANOE. New Series. No. 1, 3s. 6d.*
- 10-WATT MOTOR. New Series. No. 2, 3s. 6d.*
- COMPRESSED-AIR MODEL AERO ENGINE. New Series. No. 3, 5s.*
- AIR RESERVOIR FOR COMPRESSED-AIR AERO ENGINE. New Series. No. 3a, 1s.
- "SPORTS" PEDAL CAR. New Series. No. 4, 5s.*
- F. J. CAMM'S FLASH STEAM PLANT. New Series. No. 5, 5s.*
- SYNCHRONOUS ELECTRIC CLOCK. New Series. No. 6, 5s.*
- ELECTRIC DOOR-CHIME. No. 7, 3s. 6d.*
- ASTRONOMICAL TELESCOPE. New Series. No. 8 (2 sheets), 7s.*
- CANVAS CANOE. New Series. No. 9, 3s. 6d.*
- DIASCOPE. New Series. No. 10, 3s. 6d.*
- EPISCOPE. New Series. No. 11, 3s. 6d.*
- PANTOGRAPH. New Series. No. 12, 1s. 6d.*
- COMPRESSED-AIR PAINT SPRAYING PLANT. New Series. No. 13, 7s. 6d.*
- MASTER BATTERY CLOCK.* Blue-prints (2 sheets), 3s. 6d. Art board dial for above clock, 1s.
- OUTBOARD SPEEDBOAT. 10s. 6d. per set of three sheets.
- LIGHTWEIGHT MODEL MONOPLANE. Full-size blue-print, 3s. 6d.
- P.M. TRAILER CARAVAN. Complete set, 10s. 6d.*
- P.M. BATTERY SLAVE CLOCK, 2s.
- "PRACTICAL TELEVISION" RECEIVER. (3 sheets), 10s. 6d.
- P.M. CABIN HIGHWING MONOPLANE. 1s.*

The above blue-prints are obtainable, post free, from Messrs. George Newnes, Ltd., Tower House, Southampton Street, Strand, W.C.2.

An * denotes constructional details are available free with the blue-prints.

Metal:

- 6½ gals. white spirit.
- 2 gals. oleine.
- 1½ gals. thin mineral oil.
- 12½ lbs. silica flour.
- 7½ lbs. levigated chalk.
- ½ gal. soft water.
- 1½ lbs. caustic potash; trace of amyl acetate.

Silver:

- 5 lbs. precipitated chalk.
- 5 lbs. china clay.
- 1 lb. jeweller's rouge.
- ½ lb. ammonium sulphate.

Obtainable from good oil and colour merchants and chemical suppliers, such as Vicson and Sons, 148, Pinner Road, Harrow, Middlesex.

Reading a Height Gauge

PLEASE explain to me how to read a height gauge. I can read a micrometer.—W. Reeves (Southall).

WE presume that you refer to the vernier height gauge. The common type of vernier is the "thousandths vernier," 25 divisions on the vernier scale corresponding to 24 divisions on the main scale. The graduations on the main scale are in inches, tenths and fortieths (0.025in.). The length of the vernier plate is 0.6in. This is divided into 25 equal parts so that one of the small divisions on the vernier scale will be 0.024in., i.e., 0.001in. less than the length of a small division on the main scale.

The gauge is read by first reading the complete inches on the main scale, say 5, then the complete tenths, say 2, then the complete fortieths, say 3. Next it is noted what line on the vernier scale coincides with a line on the main scale; if line 11 on the vernier scale coincides with a line on the main scale this reading is 0.011. Then the total reading will be 5+0.2+(3×0.025)+0.011in.=5.286in.

Diametral Pitch

BELOW is a section copied from the screwcutting chart on a "Graynor" lathe. Please explain the term "Diametral Pitch," which is not normally used in screw-cutting (only in connection with gears).—J. W. Hendry (East Ham).

DIAMETRICAL PITCH				
No. on Box	LEVERS			
	AC	BC	AD	BD
1	4	8	16	32
2	4½	9	18	
3	5	10	20	
4	5½	11	22	
5	6	12	24	
6	7	14	26	
CHANGE GEARS				
Drivers	44	60		
Driven	40	42		

YOU have no doubt cut many simple worms which mesh with their appropriate wheels and are, therefore, acquainted with the terms pitch and circular pitch, etc.

Now supposing you encountered a special screw that meshed in a similar way to a gear wheel—obviously you must make the pitch relative to the teeth. Alternatively, imagine: you wished to arrange a simple rack and pinion and you did not possess a rack cutting or milling machine. Cutting a thread on a shaft and fixing it in two bearings would serve the same purpose as a rack. For fast traverse with a fine adjustment the lathe idea is useful; rotating the gear with a handwheel gives the rapid movement, and the thread

**MODERN
DRAWING
OFFICE
Furniture**

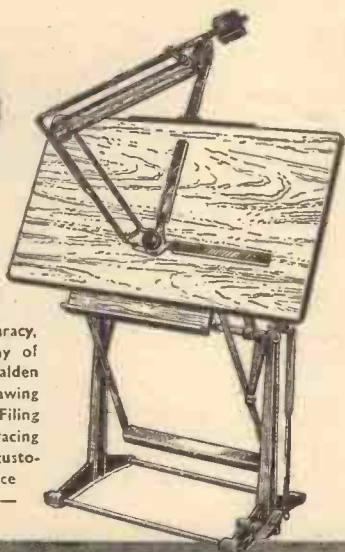

No finer range of Drawing Office Furniture is available than the Halden range. Every up-to-date refinement making for greater accuracy, greater ease in use, and economy of space has been introduced to the Halden designs. The range includes Drawing Tables, Cabinets, Drawing Boards, Filing Cabinets, Trestles and Glass Tracing Tables, Large size boards made to customer's own specification. For all office furniture and accessories consult:—



Haldens

OF MANCHESTER

J. HALDEN & CO., LTD. 8, ALBERT SQUARE, MANCHESTER, 2.
Branches at:—London, Newcastle-on-Tyne, Birmingham, Glasgow, Leeds and Bristol

E.D. DIESELS FOR YOUR MODELS



E.D. .46 BABY
Specification: Bore $\frac{1}{8}$ in. R.P.M. 9,000-12,000. Height $1\frac{1}{2}$ in. Stroke $\frac{1}{8}$ in. cu. capacity 0.46 c.c. B.H.P. 0.04. Weight 1.4 oz. with tank. Length $2\frac{1}{2}$ in. Width $1\frac{1}{2}$ in. Fuel Control placed at 30 deg. for easy access.
Price £2.12.3

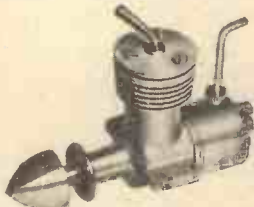

E.D. 1 c.c. (BEE)
A compact little motor with an overall height of $2\frac{1}{2}$ in. Weight $2\frac{1}{2}$ oz. Bore 0.437 in. static thrust 12 oz., stroke 0.400 r.p.m., 7,000 plus.
Price £2.14.9

E.D. 3.46 c.c. HUNTER

Developing 10,000 r.p.m. the three-forty-six is one of the finest engines for control-line and stunt flying. Stroke 0.625 in., height 3 in., width $1\frac{1}{2}$ in., length $4\frac{1}{2}$ in., weight $5\frac{1}{2}$ oz.

Price £3.18.6 (Watercooled. £5.9.3)

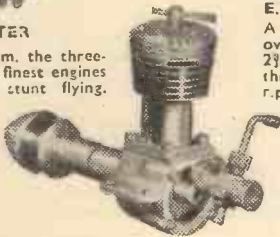

E.D. 2.46 c.c. RACING ENGINE

Specially designed for use as a diesel, glo-plug or spark ignition engine, the 2.46 develops over $\frac{1}{2}$ h.p. at 14,000 r.p.m. plus. Total weight 5 oz. Price £3.18.6 (Watercooled £5.9.3)

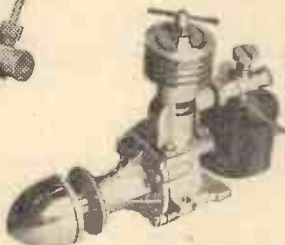

E.D. 2 c.c. COMPETITION SPECIAL

Gives 23 oz. static thrust and incorporates vernier compression adjustment. Height 3 in., width $1\frac{1}{2}$ in., length 4 in., weight $5\frac{1}{2}$ oz. Price £2.1.9 (Watercooled, £4.10.3)

ORDER THROUGH YOUR MODEL SHOP

E.D. ELECTRONIC DEVELOPMENTS (SURREY) LTD.
DEVELOPMENT ENGINEERS
1223, 18, VILLIERS ROAD, KINGSTON-ON-THAMES, SURREY, ENGLAND.

RECOMMENDED TOOLS ON BETTER TERMS

If you are commencing a workshop or extending your present workshop equipment, our well known OUT OF INCOME terms offer you a sound common-sense method of planned expenditure. Let us know your requirements; detailed quotation will be sent by return post, quite free of obligation. A 1/- stamp will bring you a copy of our comprehensive illustrated catalogue—a MUST HAVE for all model engineers.

MYFORD M.L.7

BENCH LATHE with standard equipment, £49.5.0. Deposit £12.2.0, and 12 monthly payments of 68/7. Alternatively deposit £12.2.6, and 18 monthly payments 47/11. Carriage paid.

LATHE ON CABINET STAND, motorised A.C. single phase, 273.11.2. Deposit £18.8.2, and 12 monthly payments £5.0.3. Alternatively deposit £18.9.1 and 18 monthly payments 69/6. C.P.

1423 TAPER TURNING ATTACHMENT, £10.15.0. Deposit 55/- and 12 monthly payments 14/8. C.P.

2A1495 DIVIDING ATTACHMENT £14. Deposit 70/- and 12 monthly payments 19/3. C.P.

1407 CIRCULAR SAW TABLE £5.7.6. Deposit 26/6, and 6 monthly payments 14/10. C.P.

SELECTA 4 1/2 in. D. E. GRINDERS A.C. single phase, £7.19.0. Deposit 40/- and 12 monthly payments 10/11. Carriage paid.

MYFORD M.L.8

WOODWORKING LATHE, bench model with Rear Turning attachment, £21.15.0. Deposit 109/- and 12 monthly payments 29/11. C.P.

1507 SAW TABLE, £11.15.0. Deposit 59/- and 12 monthly payments 16/1. C.P.

1549 PLANING ATTACHMENT, £16.15.0. Deposit 84/- and 12 monthly payments 23/- . C.P.

FOBCO STAR 6-in. cap. BENCH DRILLING MACHINES fitted Jacobs chuck, motorised A.C. single-phase. £35.8.9. Deposit £8.17.9, and 12 monthly payments 50/11. C.P.

PEDESTAL MODELS, £40.6.9. Deposit £10.2.9, and 12 monthly payments of 57/- . Carriage paid.

SELECTA 6in. BENCH GRINDERS, A.C. single-phase or 3-phase, £16.5.0. Deposit 81/- and 12 monthly payments 22/5. C.P.

A. J. REEVES & CO.

416, MOSELEY ROAD, BIRMINGHAM, 12
Grams: "Reevesco, Birmingham." Phone: CALthorpe 2554

"THE CHOICE OF EXPERIENCE"

Build Your Daughter This Beautiful

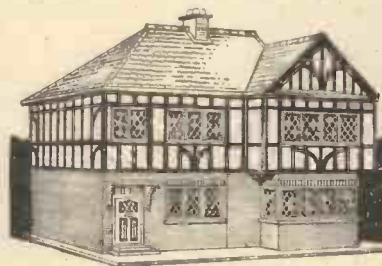

TUDOR DOLL'S HOUSE

Kit No. 237 Sp.

75/3

(Carriage Paid U.K.)

ANY handyman will enjoy making one of these grand Tudor Doll's Houses from Hobbies Kit No. 237 Special. The completed model is 2ft. wide, 2ft. high and 16ins. deep, and access is provided to the spacious interior by a double hinged front. Kit includes all necessary wood, metal "open and close" windows, door, staircase, hinges, catches and covering paper for inside and outside the house. Complete with fully detailed plans and instructions. Those who require a smaller house should obtain Kit No. 2910 for a modern house 1ft. 5ins. wide, 1ft. 4 1/2 ins. high and 10ins. deep. The cost is 48/3 carriage paid. Other Doll's House Kits are shown in Hobbies' Free Booklet and details of all Hobbies' kits and tools are contained in the 1954 Handbook. Use form below and receive your kit by post. Also obtainable from Ironmongers, Stores and Hobbies Branches.



To HOBBIES LTD., Dept. 7, DEREHAM, Norfolk.

Please send me your Free 20-page 2-colour Booklet and name and address of nearest stockist. Also send me items I have marked thus X

- 1954 Handbook 2/3, post free
- The Tudor Doll's House Kit (237 Sp.), 75/3, carriage paid
- Smaller Doll's House Kit (2910), 48/3, carriage paid

I enclose P.O. for.....

NAME.....

ADDRESS.....

enables the operator to effect the final exact measurement of the apparatus.

Messrs. John Langs Ltd., of Johnstone, near Glasgow, also incorporate module pitches in the gearboxes of their lathes, and these, as you probably are aware, relate to metric gears.

Window Display Turntable

I WOULD like to construct a wooden turntable not less than 2ft. 6ins. diameter for window display purposes. It would be required to carry and revolve a standard type pram, weighing about 50lb., about once per minute.

Can you give me the likely H.P. of the motor, and tell me if any type of ex-W.D. motor would be suitable? It has to be mains driven and run for about 3 hours at a time.—F. Knight (Norwich).

THE vertical shaft of the table will need to run in bearings at the top and bottom; there must be more than one bearing on the top of a fixed shaft because it is most unlikely that the centre of gravity of the perambulator will fall over the centre of rotation. It will, therefore, be necessary to make a rotating shaft, strongly attached to the turntable and running in a radial ball bearing at the top and a thrust bearing at the bottom as shown in the accompanying drawings.

Bearings which would be most suitable have been selected from the catalogue of The Skefco Company of Luton, Bedfordshire. The top one is self aligning and the code number is S.A. : RL.6. The thrust bearing which will carry all the weight is code number O.5; the two halves of the latter have different diameters; note that the larger diameters must be placed at the bottom and that the vertical steel shaft is shouldered to rest upon the upper half.

The turntable is made from three discs of 9mm. thick plywood well glued together as well as screwed, and the edges, after screwing up, turned in the lathe and bored $\frac{1}{2}$ in. at the centre. The whole disc is then mounted upon the upper end of the spindle which has a flanged collar fitted upon it. This collar is either a gunmetal casting or turned from mild steel. If gunmetal, it can be bored to fit the spindle and sweated on with solder. If of steel it can be heated and shrunk on, or can be brazed to the spindle.

The motor shown in the drawing is a Klaxon geared unit—that is to say, it is a small fractional horsepower machine which is incorporated with a gearbox, approximately as shown.

The Klaxon people make these with the final output shaft to come out at either side of the gearbox or at the end, in line with the armature shaft, or vertically at the top. Further, within reason, any final revolution speed is obtainable.

In the present case a vertical shaft will be required if the scheme shown in the drawing is adopted.

In your letter you desire a revolution speed, for the turntable, of one per minute. The diameter has been made 2ft. 8in., i.e., 32in.; this multiplied by $3.1416 = 100.53$ in. circumference. Ignoring the decimal fraction, any point on the periphery will travel 100in. in one minute. If the geared motor shaft is made to revolve at 50 revs. in 1 minute, then the pulley on same (which will drive the turntable by friction) will have a circumference of approximately 2in., or a diameter of .628in., a little less than $\frac{3}{8}$ in. or say $\frac{1}{2}$ in. It is suggested that the pulley be formed by a thick rubber tube, or tubes one inside of the other, forced over the end of the shaft on the gearbox. Of course the outer surface of the tube or tubes must run true. The motor is mounted on a radially movable platform, so arranged that it can rock laterally in relation to the edge of the turntable. To a strip steel arm screwed to the underside of the platform a spiral spring is attached, which spring is anchored to a screw eye or hook in one of the four supports provided to carry the upper or radial bearing.

In setting up the display in a window or showroom a spirit level will be required to ensure that the turntable is dead level at all points in its revolution. Were it out of level and the centre of gravity not coincident with the centre of the table—which with a perambulator it almost certainly would not be—the load on the pulley and gearbox would not be equal during each half revolution of the table.

Chrome Plating Queries

WOULD you please give me some guidance regarding the following faults which I have encountered in my trials?

The deposited chromium is dull, thin, and almost looks like lead coating, and does not deposit very evenly and will not polish.

The circuit resistance that I made in accordance with your data does not adjust the current gradually, and seems to send suddenly a surge of current when the two copper electrodes must

be almost touching. At this point the solution emits a buzzing sound; close adjustments are almost impossible.

I used a car battery case, thoroughly cleaned, for the vat.

I used 3 pints of distilled water, 500 grammes of chromic acid (Chromii Trioxidum on the label), and 60 drops of sulphuric acid.

The caustic soda solution I made with ordinary water, and the nitric acid solution also. Would this affect the results?—S. E. Pickering (Essex).

CHRONIUM plate is so hard that it is almost impossible to polish it, hence all the necessary polishing should be carried out on the surface of the base immediately before chromium plating. Iron is difficult to polish and the deposition of a plate of some other metal which will take a high polish, between iron and chromium, is indicated.

A dull grey mat deposit may result from excessive current or an excess of sulphuric acid. It is advisable that the temperature of the vat be kept at about 45 deg. C., and the current density may be about 12 amps per square decimetre. We suggest a solution consisting of 40 ozs. of pure chromic acid (dry crystals), with 4 fluid ozs. of dilute sulphuric acid B.P. (10 per cent. acid) to one gallon of distilled water. We do not advise using tap water. It occurs to us that the difficulty you have experienced in controlling the current may have been due to the anodes being placed too near to the work.

Information Sought

Readers are invited to supply the required information to answer the following queries.

Mr. Cutler's query on page 530 of the September issue makes reference to mounting maps on fabric with an open mesh. When closely-woven heavily-dressed material is being used the usual process is to stretch on a drawing board, and secure with many drawing pins a piece of suitable size; after it has been pasted on the back the map is turned over in the air, laid on the mounting material and smoothed down outwards from the centre. This usually calls for a second pair of hands. How does Mr. Cutler prevent the paste from penetrating the open mesh, thus sticking the whole to the board while it is drying?

On a further point, can any reader kindly recommend a solvent that will soften boot blacking which has hardened as the result of careless replacement of a lid? None of the common domestic fluids such as vinegar, ammonia, paraffin, petrol, methylated spirit, or linseed oil, etc. will answer.—G. LOVE-GROVE (Frome).

A. M. Cooper, of Walthamstow, asks: "Can any reader supply the name and address of a firm from whom a constructional kit of parts for making an electronic flash gun can be obtained?"

A Correction

In the August issue of PRACTICAL MECHANICS, page 463, an illustration is given bearing the caption, "Mr. S. England's model farm and camp." This is incorrect, the caption should read—Mr. W. Plummer's model zoo.

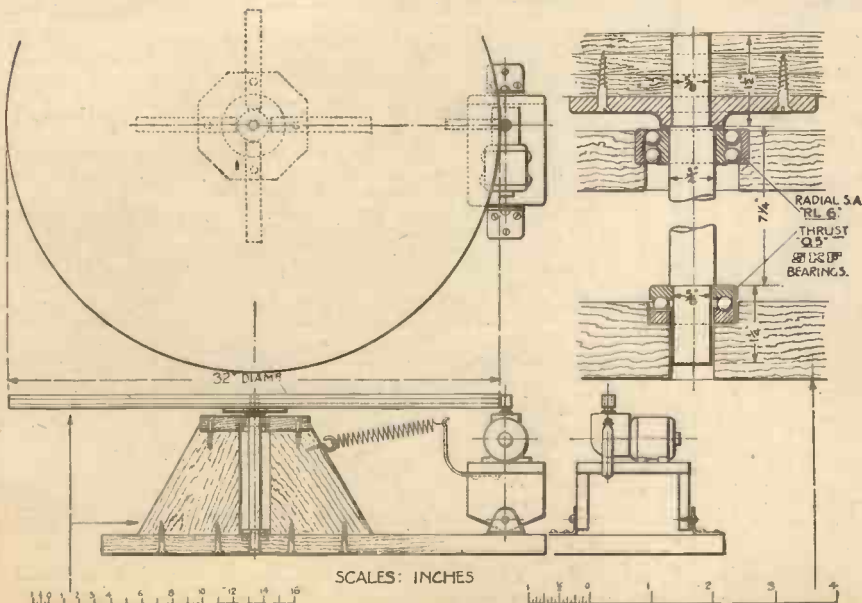

Suggested arrangement for window display turntable.