

THE MAGNETIC MINE EXPLAINED

NEWNES

# PRACTICAL MECHANICS

JUNE 1940

6<sup>D</sup>

IN  
AUSTRALIA  
and  
NEW ZEALAND



# DO NOT CONCENTRATE ON WAR

Do not concentrate your thoughts upon war subjects. You will find it very worrying and very bad for the nerves.

Read, write, sketch, paint, study your vocation; anything that will occupy your mind and your time. Make use of your spare time by concentrating upon something useful.

During the last war many people learned how to write short stories, etc., to-day a number of them are world-famed authors.

By becoming efficient in your vocation, you can give the best service to your country and to yourself. The more you increase your earning power the better it is for the country and for yourself personally.

War or no war, earning power always brings its possessor to the front. It is no use waiting for better times. The ideal opportunity never arrives. We have to make the best of existing conditions. Therefore, delay is useless; it is worse, it is harmful.

## DO ANY OF THESE SUBJECTS INTEREST YOU?



Accountancy Examinations  
Advertising and Sales Management  
Agriculture  
A.M.I. Fire E. Examinations  
Applied Mechanics  
Army Certificates  
Auctioneers and Estate Agents  
Aviation Engineering  
Banking  
Blue Prints  
Boilers  
Book-keeping, Accountancy and Modern Business Methods  
B.Sc. (Eng.)  
Building Architecture and Clerk of Works  
Builders' Quantities  
Cambridge Senior School Certificate  
Civil Engineering  
Civil Service  
All Commercial Subjects  
Commercial Art  
Concrete and Structural Engineering  
Draughtsmanship. All branches

Engineering. All branches, subjects and examinations  
General Education  
G.P.O. Eng. Dept.  
Heating and Ventilating  
Industrial Chemistry  
Institute of Housing  
Insurance  
Journalism  
Mathematics  
Matriculation  
Metallurgy  
Mining. All Subjects  
Mining, Electrical Engineering  
Motor Engineering  
Motor Trade  
Municipal and County Engineers  
Naval Architecture  
Novel Writing  
Pattern Making  
Play Writing  
Police, Special Course  
Preceptors, College of Press Tool Work  
Production Engineering

Pumps and Pumping Machinery  
Radio Communication  
Radio Service Engineering  
Road Making and Maintenance  
Salesmanship. I.S.M.A.  
Sanitation  
School Attendance Officer  
Secretarial Exams.  
Sheet Metal Work  
Shipbuilding  
Shorthand (Pitman's)  
Short-Story Writing  
Speaking in Public  
Structural Engineering  
Surveying  
Teachers of Handicrafts  
Telephony and Telegraphy  
Television  
Transport Inst. Exams.  
Viewers, Gauges, Inspectors  
Weights and Measures Inspector  
Welding  
Wireless Telegraphy and Telephony  
Works Managers



If you do not see your own requirements above, write to us on any subject. Full particulars free.

## STUDY AT HOME IN YOUR SPARE TIME

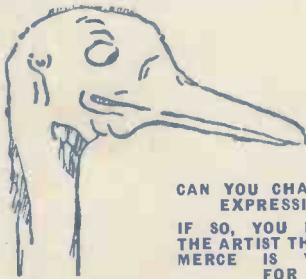

CAN YOU CHANGE MY EXPRESSION?  
IF SO, YOU MAY BE THE ARTIST THAT COMMERCE IS WAITING FOR

*Jim Duck*

Just try it for yourself. Trace or draw the outline and then put in the features

There are hundreds of openings in connection with Humorous Papers, Advertisement Drawing, Posters, Calendars, Catalogues, Textile Designs, Book Illustrations, etc.

60 per cent. of Commercial Art Work is done by "Free Lance Artists" who do their work at home and sell it to the highest bidders. Many Commercial Artists draw "retaining fees" from various sources, others prefer to work full-time employment or partnership arrangement. We teach you not only how to draw what is wanted, but how to make buyers want what you draw. Many of our students who originally took up Commercial Art as a hobby have since turned it into a full-time paying profession with studio and staff of assistant artists; there is no limit to the possibilities. Let us send full particulars for a FREE TRIAL and details of our course for your inspection. You will be under no obligation whatever.

*Jim Duck*

ART DEPT. 76

## LET ME BE YOUR FATHER

Let me tell you how to make a success of your career.

If your future is undecided or appears unsatisfactory, let us talk it over together.

I want to help, and it will cost you nothing to get my help; you will be under no obligation whatever.



## I HAVE HELPED THOUSANDS OF OTHERS

And when I say thousands, I do not exaggerate, as I can produce well over 10,000 unsolicited testimonials from grateful students who, through our Postal Training, have achieved their life's ambition.

*W. Bennett*



Dept. 76, THE BENNETT COLLEGE, SHEFFIELD

## EVERY DEPARTMENT IS A COMPLETE COLLEGE: EVERY STUDENT IS A CLASS TO HIMSELF

### JOURNALISM Short-Story, Novel and Play Writing

There is money and pleasure in Journalism and in Story Writing. No apprenticeship, no pupillage, no examinations, no outfit necessary. Writing for newspapers, novels or pictures is not a gift; it is a science that can be acquired by diligent application and proper guidance. It is the most fascinating way of making pastime profitable. Trained ability only is required; we do the training by post. Let us tell you about it.

### DEPARTMENT OF LITERATURE 76

If you attend to this now, it may make a wonderful difference to your future.

### COUPON—

CUT THIS OUT

To Dept. 76, THE BENNETT COLLEGE, LTD., SHEFFIELD  
Please send me (free of charge)



Particulars of.....  
Your private advice about  
(Cross out line which does not apply)

PLEASE WRITE IN BLOCK LETTERS

Name .....

Address .....

E. PULL'S

# Modern Workshop Practice

By F. JOHNSTONE TAYLOR

780 PAGES

542 ILLUSTRATIONS

This complete compendium of practical teaching on Modern Workshop Practice contains trad<sup>e</sup> knowledge indispensable for Engineers, Apprentices, Improvers, and all engaged in Engineering Trades.

**FREE APPROVAL is the Best Test of Value**

LIST OF THE CONTENTS

MEASUREMENTS AND MEASURING MACHINES  
 MEASURING TOOLS  
 GAUGES AND GAUGE SYSTEMS  
 COMMON WORKSHOP TOOLS  
 BENCH WORK  
 MATERIALS:—CAST IRON  
 HEAT TREATMENT OF METALS  
 SOLDERING, BRAZING, AND LACQUERING  
 LATHES  
 TOOL HOLDERS  
 LATHE-TOOLS, SPEEDS, AND FEEDS  
 LATHE ACCESSORIES  
 TURNING  
 SCREWS AND SCREW CUTTING  
 TURRET LATHES  
 CAPSTAN AND TURRET LATHE TOOLS

PLAIN AND UNIVERSAL MILLING  
 GEAR AND GEAR CUTTING  
 GEAR HOBBING AND PLANING MACHINES  
 BORING AND SLOTTING MACHINES  
 PLANING, SHAPING, AND DRILLING  
 PLAIN AND UNIVERSAL GRINDING  
 FORGE TOOLS AND PROCESSES  
 WELDING  
 SPECIAL GRINDERS: FIVE MACHINES  
 THE ENGINEER'S SQUARE: THREE TYPES OF  
 STEEL SQUARES AND A COMBINATION SQUARE  
 DESCRIBED  
 TESTING A TRY-SQUARE  
 TABLES (Measures, Rules, etc.)  
 INDEX OF 2,000 ITEMS

**FREE EXAMINATION FORM**

**NO CHARGE AND NO OBLIGATION TO ORDER**

To VIRTUE & CO., LTD., P.M. Dept., 19 Thavies Inn, London, E.C.1.

Please send me "MODERN WORKSHOP PRACTICE." Price 17/6. I will return it in one week, or send you 3/- deposit and the balance by monthly payments of 3/-. (Cash Price 16/6).

Signature..... (Send this form in unsealed envelope stamped 1d.)

Address .....

Occupation .....

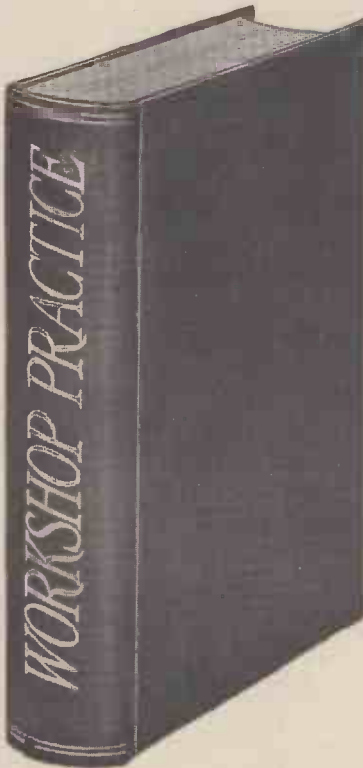

## THE "FLUXITE" QUINS AT WORK



"Oh dear," exclaimed Oo with a squeak,  
 "This saucepan has sprung such a leak,"  
 She needn't have worried  
 The other quins hurried  
 Fluxited it—ere you could speak!

See that FLUXITE is always by you—in the house—garage—workshop—wherever speedy soldering is needed. Used for 30 years in Government works and by leading engineers and manufacturers. Of ironmongers—in tins, 4d., 8d., 1/6 and 2/6. Ask to see the FLUXITE SMALL SPACE SOLDERING SET—complete but substantial—complete with full instructions, 7/6. Write for Free Book on the ART OF "SOFT" SOLDERING and ask for Leaflet on CASE-HARDENING STEEL and TEMPERING TOOLS with FLUXITE.

TO CYCLISTS! Your wheels will NOT keep round and true unless the spokes are tied with fine wire at the crossings and SOLDERED. This makes a much stronger wheel. It's simple—with FLUXITE—but IMPORTANT!

THE FLUXITE GUN is always ready to put Fluxite on the soldering job instantly. A little pressure places the right quantity on the right spot and one charging lasts for ages. Price 1/6, or filled 2/6.

FLUXITE Ltd., Dept. P.M., Dragon Works, Bermondsey Street, S.E.1

ALL MECHANICS WILL HAVE

# FLUXITE

IT SIMPLIFIES ALL SOLDERING

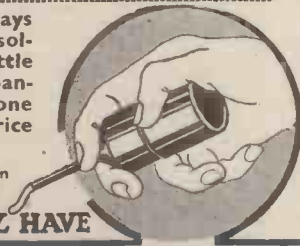

## MORSE CODE MADE EASY

LEARN MORSE with this Tapping Key, on which the Morse Code is engraved. The gap is adjustable. Key is wired to work Buzzer or Flash Lamp, using 4 1/2" Battery or Transformer illustrated. Key, with heavy brass rocker arm 3/6 POST FREE, or CHROMIUM-PLATED 4/- POST FREE. JUNIOR MODEL 2/- POST FREE.

Super Models mounted on wood bases as follows:—NICKEL-PLATED, simple tension adjuster, 6/6 POST FREE. CHROMIUM PLATED, simple tension adjuster, 7/- POST FREE. ALL BRASS, Vernier tension adjuster, NICKEL CONTACTS carry in current at 5 amps., 7/6 POST FREE.

### BUZZERS

No. 1. Oval. 1/6 POST FREE  
 No. 2. Larger, slightly better model. 2/- POST FREE  
 No. 3. Heavy Duty. Double-Coil Buzzer. 3/- POST FREE

Should you require a complete outfit, our DX/2 Set is a Chromium Key mounted on a large polished board and wired to a Heavy Duty Double Coil Buzzer, Flash Lamp Bulb-holder and a switch to bring either into circuit. A VERY FINE JOB 14/6 POST FREE. Money refunded of course if you are not completely satisfied.

### BELL TRANSFORMER

This transformer gives, 3, 5 or 8-volt output, operates a bulb, buzzer or bell. Also provides an A.R.P. light in bedroom, shelter, etc. 4/- POST FREE.

Ask for our List A.M. of useful Electrical Accessories.  
**HIGHSTONE UTILITIES, 58, NEW WANSTEAD, LONDON, E.11**

## E. GRAY & SON, LTD.

### BENCH GRINDERS

Wheel size  
 3" x 1" 4/2  
 4" x 1" 5/-  
 5" x 1" 5/2  
 6" x 1" 8/-

### MICROMETERS

0-1" American Plain 21/-  
 0-1" "Lufkin" Ratchet and Locknut ... 46/6  
 0-1" "Browne & Sharpe" Ratchet and Locknut 69/-

### VEE-BLOCKS: Steel, 2" x 1" ... 4/6 pair "Browne & Sharpe," 2 blocks, 1 clamp ... 11/6 set

18-20 CLERKENWELL RD., LONDON, E.C.1  
 Phone: CLE 1174 Est. 1822

# ENGINEERS!

**EQUIP YOURSELF FOR WORK OF NATIONAL IMPORTANCE**

**BY BECOMING TECHNICALLY QUALIFIED**



Men with technical knowledge are as important as troops and ammunition. For the country's immediate needs and your own future gain you are urged to send immediately for a free copy of "ENGINEERING OPPORTUNITIES." Containing 268 pages of practical guidance, this book is, beyond argument, the finest and most complete handbook on Successful Engineering Careers ever compiled. It is a book that should be on the bookshelf of every person interested in engineering, whatever his age, position or experience. The Handbook contains, among other intensely interesting matter, details of B.Sc., A.M.I.C.E., A.M.I.Mech.E., A.M.I.E.E., A.M.I.A.E., A.M.I.W.T., A.M.I.R.E., Civil Service and other important Engineering Examinations; outlines courses in all branches of Civil, Mechanical, Electrical, Automobile, Radio, Television and Aeronautical Engineering, Draughtsmanship, Tracing, Inspection, Building, Government Employment, etc., and explains the unique advantages of our Employment Department.

*Brighten  
your  
future  
by  
Studying  
through  
the  
Black-  
Outs*

**WE DEFINITELY GUARANTEE  
"NO PASS-NO FEE"**

If you are earning less than £10 per week you cannot afford to miss reading "ENGINEERING OPPORTUNITIES." In your own interests we advise you to write (or forward the coupon) for your copy of this enlightening guide to well-paid posts—NOW.

*There is no cost or obligation of any kind.*

**BRITISH INSTITUTE OF  
ENGINEERING TECHNOLOGY**

**410a, SHAKESPEARE HOUSE,  
17, 18 & 19, STRATFORD PLACE, LONDON, W.1**

-----TEAR OFF HERE-----  
**FREE COUPON**

**BRITISH INSTITUTE OF  
ENGINEERING TECHNOLOGY,**

410a, Shakespeare House,  
17-19 Stratford Place, W.1.

Please forward, Free of cost or obligation of any kind, your 268-page Handbook, "ENGINEERING OPPORTUNITIES."

Name.....

Address.....

.....  
.....  
.....

## SUBSCRIPTION RATES

Inland and Abroad 8s. 6d. per annum.  
Canada - - 8s. per annum.

Editorial and Advertisement Office: "Practical  
Mechanics," George Newnes Ltd.  
Tower House, Southampton Street, Strand, W.C.2.  
Phone: Temple Bar 4363.

Telegrams: Newnes, Rand, London.

Registered at the G.P.O. for transmission by  
Canadian Magazine Post.

Copyright in all drawings, photographs, and  
articles published in "Practical Mechanics"  
is specifically reserved throughout the  
countries signatory to the Berne Convention  
and the U.S.A. Reproductions or imitations  
of any of these are therefore expressly  
forbidden.

# PRACTICAL MECHANICS

Owing to the paper shortage "The Cyclist" is temporarily incorporated

Editor: F. J. CANN

VOL. VII. JUNE, 1940, No. 81

## The Paper Shortage

A REFLECTION of the German invasion of Norway is to be found in the inclusion in this issue of *The Cyclist Supplement*. My readers do not need to be told of the paper shortage brought about by this invasion, for about 70 per-cent of the raw material from which paper is made comes from Norway and Sweden. About 30 per-cent comes from Canada. The paper shortage does not affect only this country, for all nations drew upon the Scandinavian supply and thus there is an almost equal shortage all over the world. The competitive sources of supply are not able suddenly to make good the deficiency. Thus, it has been found necessary for newspapers and periodicals either to reduce the number of their pages, or to suspend publication until the position improves.

The latter course has been adopted with our companion journal *The Cyclist*, which was without an adequate supply of paper on which to print its enormous circulation. It would not have been a practicable proposition with the small supplies available to have printed a third of the number of copies with fewer pages in each. Strenuous efforts are being made, however, to remedy the position, and our readers will join with us in hoping that the situation will rapidly mend so that once again our sister journal will reappear as a separate entity to carry on its important work. It is unnecessary for me to stress that publication of *The Cyclist* is only suspended. It has not ceased publication. When it reappears, as it undoubtedly will, announcements will appear in the daily papers apprising all cyclists of the fact, and also in all George Newnes publications.

The supplement which appears in this issue will preserve the continuity of publication, and it will include not only a news summary, but certain of the features which made *The Cyclist* the leading cycling journal. Apparently no one foresaw the possibility of the paper shortage, and almost overnight the

## FAIR COMMENT

By the Editor

publishing trade was placed on the low ration of 30 per-cent of its normal supplies.

PRACTICAL MECHANICS readers will, I am certain, appreciate the addition of these cycling features, now that almost everyone is riding a bicycle, including motorists.

### Only to Order

NEWSPAPERS and periodicals are now only supplied to regular order because newsagents are not permitted to return unsold copies. Very few newsagents will purchase supplies on the off-chance of selling copies for which they have not orders. They are thus confining their orders to publishers in strict conformity with the number of firm orders they themselves receive from members of the public. Every reader must now place an order with his newsagent for the regular delivery of PRACTICAL MECHANICS.

Every individual and every industry is affected by war, and each must make a contribution to the war effort. The publishing trade is no exception, and the paper shortage renders it imperative that we should print only those copies which are actually required. It is in the national as well as your own interests that, if you have not already done so, you should place the order with your newsagent without delay, otherwise you may find that next month the newsagent is without your usual copy.

### The New Source of Power

ACCORDING to reports, American scientists have succeeded in isolating a new substance known as U-235. It is a chemical similar in composition to uranium, and it is claimed to be a potential source of immense power. So far only a minute quantity of the substance has been isolated, but it is estimated that one pound would give off sufficient energy to drive a liner or

a battleship for a long period without refuelling. It is said that the energy from U-235 can be liberated by pouring cold water over it when great quantities of steam are given off.

We must, of course, not be too optimistic that we shall be able to harness this power until some years have passed. There have been many claims to the discovery of new sources of power, and it is not so many years since Professor Turner conducted his experiments in the splitting of the atom from which it was expected enormous power would be derived.

Dry ice is one source of power. It is really frozen carbon dioxide, and the enormous pressure which must have been exerted during the centuries is released when water is poured over it. It is, of course, a mineral.

### Demand for Books

ONE of the results of the paper shortage has been that those engaged in a technical occupation are rushing to buy books whilst present stocks last and such are available at the old prices. Undoubtedly, new editions will be sold at an increased price. Readers are, therefore, urged to purchase books now. New books in our list include "The Dictionary of Metals and Their Alloys," "Short-wave Manual," "Practical Wireless Service Manual," "Workshop Calculations Tables and Formulæ," "Practical Mechanics Handbook," "Wireless Transmission for Amateurs," and "Sixty Tested Wireless Circuits." New books in the press are "Watches: Their Repair and Adjustment," "The Super-het Manual," "The Diesel Handbook," and "The Radio Engineer's Pocket Book."

### Queries

WILL readers please note that all queries must be accompanied by a stamped addressed envelope, three penny stamps, and the coupon cut from the current issue. Otherwise the queries will be replied to in our queries columns.

# Combating the Magnetic Mine

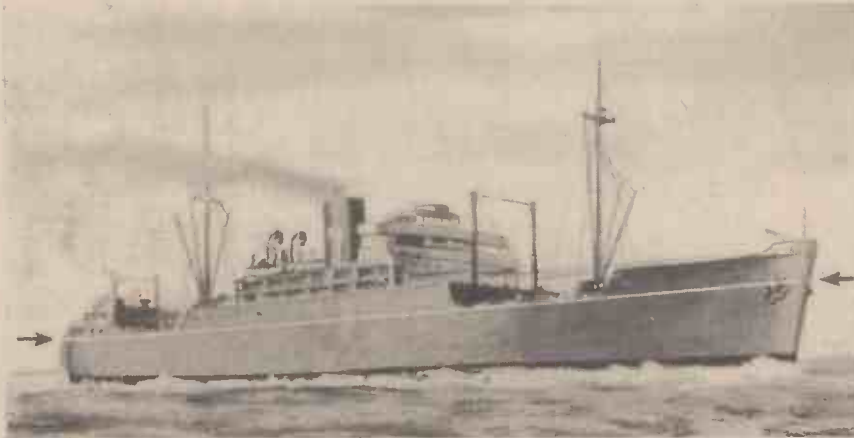

A ship fitted with a "de-gaussing" girdle as a protection against the magnetic mine.

SOME time ago the magnetic mine—Hitler's "secret weapon" we were told—was much vaunted by the enemy and regarded with suspicion by us. Its "secrets" did not remain secret for very long, however, for, once the technical experts of our Admiralty were able to lay their hands on one, they soon exploded any myths which had been woven round it.

A magnetic mine taken to H.M.S. *Vernon* was rendered harmless by Lieut.-Commander Ouvry and his staff, and later completely dismantled and studied in detail. This was a tricky and dangerous business and a piece of work deserving of more praise than is generally given to the technical departments of our services.

Not only was the operation of the mine revealed, but within a very short time a simple and comparatively inexpensive piece of equipment had been devised which rendered the mine harmless.

As the name indicates, the magnetic mine is detonated when a large mass of metal is brought within range of it. Thus, when the mine is lying on the sea bed and a ship, other than a wooden one, sails over the spot where it lies, the magnetic field of the ship causes a magnetised needle to be attracted. When this happens a pair of contacts is closed, a relay operated, and the electrical detonator energised.

Now that the mine has been dismantled and its operation understood, the simplicity of the principles employed is surprising.

## Dropped by Parachute

It may be seen from the accompanying illustrations that the mine itself consists of a charge of about 650 lb. of high explosive, the simple electrical equipment, and a compact parachute. The mine is also in the nature of a bomb, for in addition to the electrical detonating apparatus, there is an impact detonator. Thus, should the mine strike a solid object during its descent, the mechanical detonator would be operated.

As soon as the mine is released from an aeroplane—planes were apparently used invariably in laying these mines—a pointed cowling opens and falls away. This allows a closely-folded parachute to open. As a result, the mine is lowered comparatively slowly on to the sea. The parachute then becomes unhitched and the mine sinks to the sea bed. Due to the provision of horns or short legs, the mine lies on an even keel awaiting the approach of a ship.

## Balanced Magnetic Needle

When a ship comes within range, its magnetic field causes a balanced magnetic needle, comparable with the needle of a magnetic compass, to turn on its pivot. In doing so it closes a contact in an electrical circuit. Only a small current passes through that primary circuit, but it is sufficient to actuate a relay which controls the heavier current supplied by a battery to the electrical detonator. And as soon as current is applied to the detonator the powerful charge is exploded.

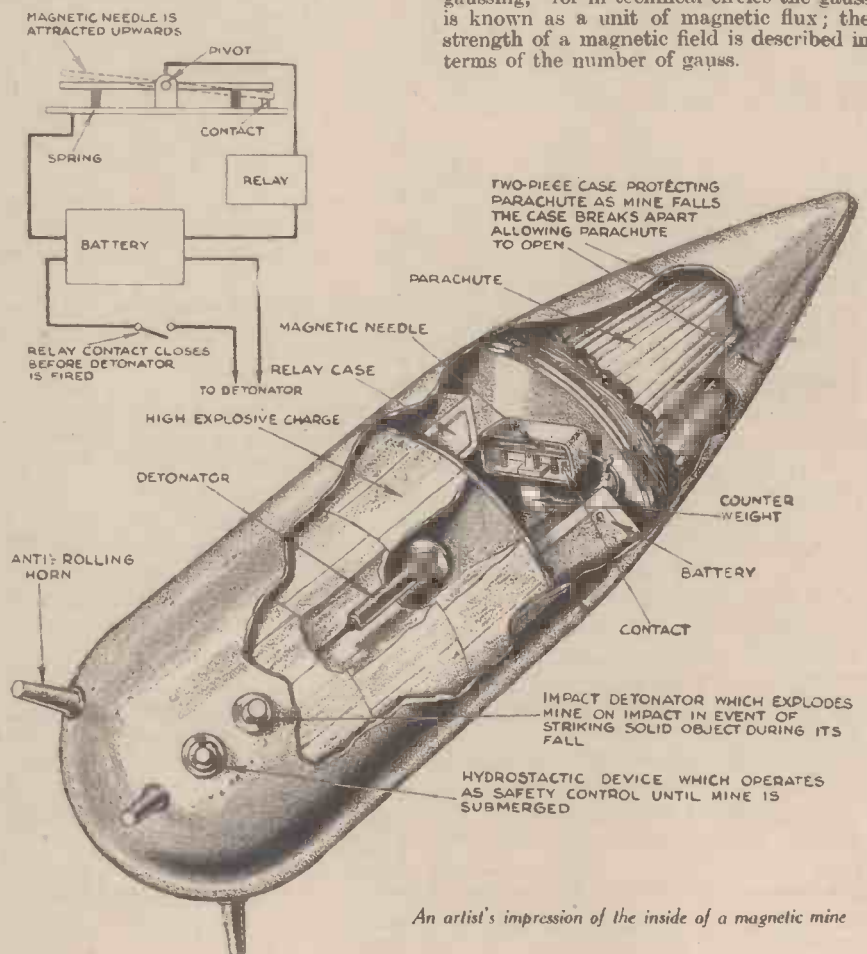

*How The Magnetic Mine Operates And How It Is Rendered Harmless By Fitting "De-Gaussing" Girdles To Our Ships*

There is another interesting device which forms a part of the magnetic mine. The purpose of this is to prevent the mine from exploding accidentally before it reaches the sea bed. In principle, it consists of a piston-type plunger at the end of which is a contact. Another contact is placed in line with this, and the two are included in the circuit of a relay connected in the detonator circuit. Because of this arrangement, the electrical detonator cannot operate until these relay contacts are closed. As readers know, hydrostatic or water pressure increases with the depth of water.

The hydrostatic control is so arranged that its contacts do not close until the mine has sunk to a depth governed by the loading of the piston plunger.

From the above explanation it would appear that the only way to render the magnetic mine immune would be to use wooden ships. That, of course, is entirely impracticable, so experiments were conducted with a view to finding a fairly simple method of demagnetising steel ships of all kinds. The name given to this is "de-gaussing," for in technical circles the gauss is known as a unit of magnetic flux; the strength of a magnetic field is described in terms of the number of gauss.

An artist's impression of the inside of a magnetic mine

# HOW THE MAGNETIC MINE IS LAID

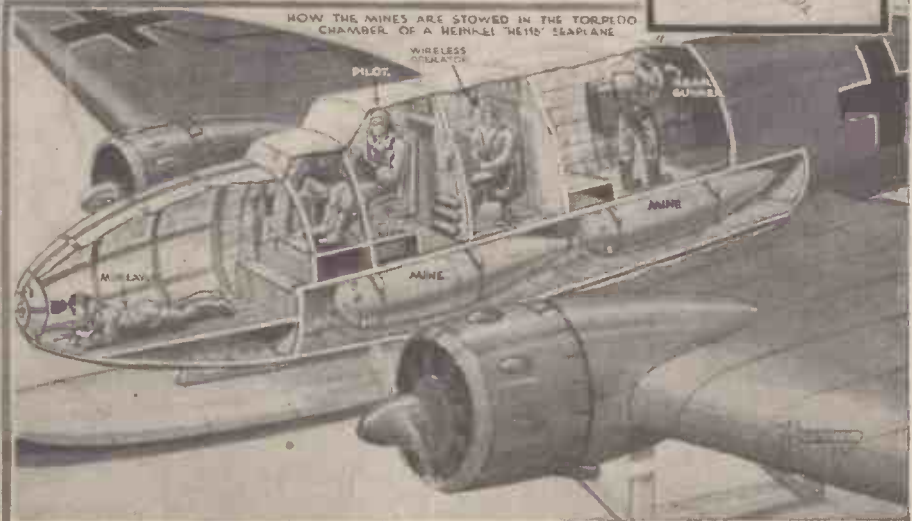
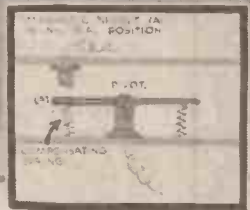
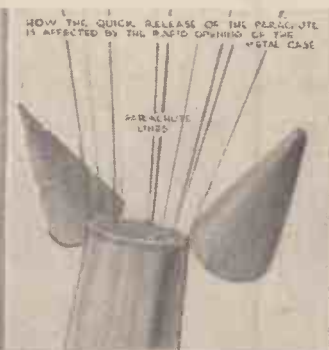
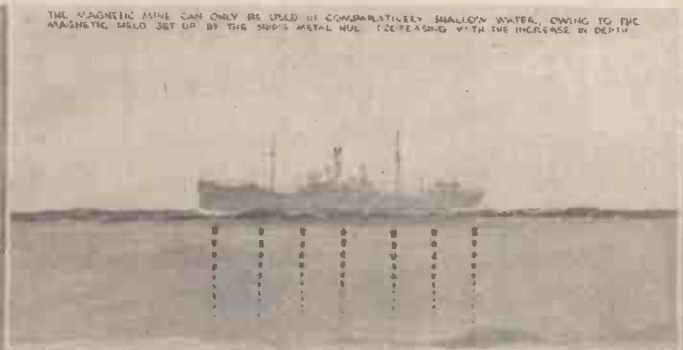

By Courtesy of Illustrated London News

The magnetic mine is similar in shape to an aerial bomb, is 8ft. long and weighs about 1,200 lb. Explosives are packed in the forepart, the firing gear is in the middle and a detachable parachute which operates as shown in the diagrams is fitted in the end. As a ship passes over the mine as it lies on the sea bed, it causes the magnetic needle to close the circuit and so fire the charge.

Successful results were very soon achieved, the method being to fit a girdle of electric cable right round the hull of the ship at deck level and to energise this in a manner which has been kept a close secret. As a result of the D.G. equipment (as the de-gaussing fitment is described), it has been possible, at moderate cost and in one to four days, to render any ship immune from the effects of the magnetic mine. The extreme efficacy of D.G. equipment is

proved by the fact that not a single ship fitted with it has been damaged by magnetic mines. Probably all of our ships are now so equipped, so the dangers of the "secret" weapon have been removed.

#### The Queen Elizabeth

The D.G. device first became known to the public after the crossing of the Atlantic by the *Queen Elizabeth*, which was one of the first ships to be "de-gaussed." It was

not long before the girdle was fitted to nearly every Allied ship of every kind and size.

This brief account lends support to the theory that there cannot be any weapon against which an antidote cannot be found. In war, however, success depends very largely on the speed with which both weapon and counter-weapon can be devised. We in this country, however, can be proud of the speed and efficiency with which our technicians laid the bogy of the magnetic mine.

# Drilling in the Lathe

## *A Method of Carrying Out Drilling Jobs with Great Accuracy*

IN the case of certain drilling jobs which require great accuracy, the firm and accurate-fitting mandrel of the lathe headstock is a valuable asset. The spindle of the usual drilling machine is never so accurately fitted as that of the lathe, and it is often possible to take advantage of the lathe mandrel for special work. If, for instance, it is necessary to drill holes dead square with a surface, the lathe can be made use of in the manner shown in Fig. 1.

The drill or cutter should not be held in the three-jaw chuck; few three-jaw chucks which have been in use any length of time can be depended upon to run a drill dead true. The drill should have a taper to suit the taper in the end of the lathe mandrel which takes the lathe centre. These tapers are generally to Morse standard, and drills with Morse taper shanks should be used.

#### A Taper Adapter

If the lathe mandrel has a different taper from the Morse standard, an adapter can be used as shown in section in Fig. 2. This adapter is turned from cast-steel rod, and is extended in the form of a  $\frac{3}{8}$ -in. rod to project out at the rear end of the hollow lathe mandrel, where it is provided with a washer and hexagon nut. This is for the purpose of drawing the adapter socket hard down into the lathe taper so as to get sufficient frictional grip on the taper to transmit power to drive the drill.

The forward end of the adapter is bored out to a Morse taper, reamed with a Morse taper reamer, and slotted at the end of the taper (by drilling and drifting with a cross-cut chisel and filing) to take the flat end of the Morse drill or Morse adapter—according to the size of the work being done.

The drill plate, against which the work is held or bolted, is shown in perspective in Fig. 3. It is a casting in iron made from a pattern, using  $\frac{1}{2}$ -in. timber. The vertical piece is about twice the height of the lathe mandrel centre above the bed. For a  $4\frac{1}{2}$ -in. lathe it will be  $7\frac{1}{2}$  in. high. The bottom piece will be 3 to 4 in. long. The top and bottom pieces must be exactly at right-angles with each other.

The pattern is screwed together, the vertical and horizontal pieces being screwed up against each other and glued, while a small fillet is glued into the corner. The bottom piece has two tenons screwed up to it. These should both be about 1 in. long, and as they are to fit in between the ways of the lathe bed, they should be a little wider than that space to allow for shaping up.

The boss is bradded and glued at the

back. This boss should be 1 in. in diameter and central between the two upright sides of the pattern. The centre of the boss should be at the same height from the bottom of the bottom piece as the height of the lathe centre above the lathe bed. It is a simple pattern, without core boxes, and will be moulded and cast on its side.

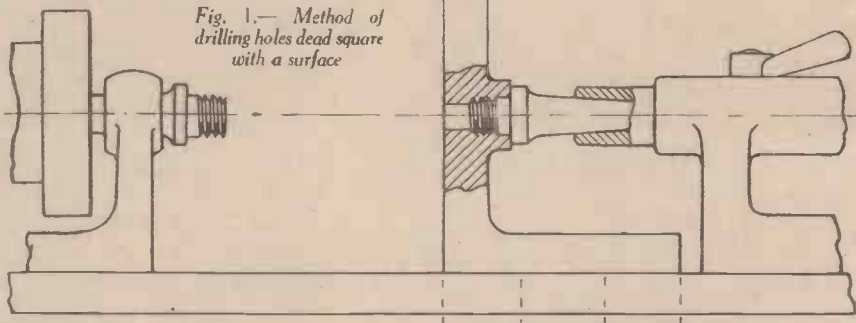

Fig. 1.—Method of drilling holes dead square with a surface

#### Machining the Casting

It will be noticed from Fig. 1, that the drilling plate is fitted with a rearwardly-extending centre which fits the barrel of the lathe tail-stock, and that it is traversed up

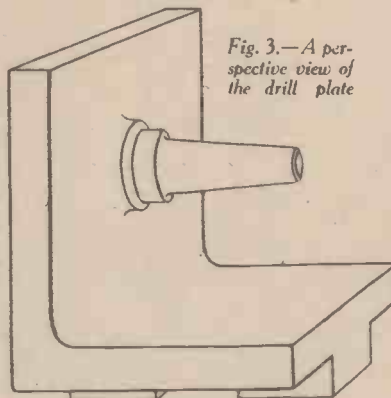

Fig. 3.—A perspective view of the drill plate

by the hand wheel on the tail-stock for feeding the work up to the drill. It is necessary, therefore, so to arrange the drilling plate that the bottom plate contacts with the lathe ways, that the steel centre registers accurately with, and fits into, the tail stock barrel, while the face of the work plate is vertical and also square with the lathe axis.

To accomplish this, the casting is first filed flat on the front face. The bottom face is

then filed flat between the tenons and square (determined by a square) with the front face. The tenons are then filed to fit between the lathe bed ways accurately and without shake. A small ( $\frac{1}{8}$  in.) drill is then chucked in the lathe three-jaw chuck, extending beyond the chuck jaws not more than  $\frac{1}{8}$  in., and the casting is fed up by hand along the bed with the front face towards the drill, and a hole  $\frac{1}{8}$  in. deep is drilled. The casting is then reversed and a similar hole is drilled in the same way from the boss side of the casting. The drill is then

extended in the chuck and the hole drilled right through by feeding the plate up by the tail-stock barrel. Afterwards it is opened out by a larger drill to the tapping size of the taper centre to be screwed into it.

This centre has the same taper as the tail-stock barrel, and is turned from cast-steel bar. Its end is shouldered, as shown, and is screw-cut to fit the tapped hole in the boss of the drilling plate. This screw thread is cut before the centre is tapered, but after it has been turned parallel at the back of the shoulder or collar.

#### Testing for Accuracy of Cut

The screw thread may conveniently be  $\frac{1}{8}$  in. Whitworth. The centre hole in the plate is then faced off at the end of the boss by a pin cutter, and the centre screwed in up to the shoulder, the parallel shank projecting. By this shank, tightly screwed up, we chuck the plate in the three-jaw chuck of the lathe with the bottom plate lying below the chuck, i.e., clear of the chuck so that it swings round the lathe mandrel.

The plate is now, of course, chucked square with the centre, and can be faced up by the cross slide of the compound rest. If the headstock has been raised it must be bolted down dead in line with the lathe bed.

The centre should now be screwed out of the plate, chucked between lathe centres and the parallel part, which we have been using for chucking the plate in the three-jaw chuck, should be turned taper in the headstock barrel. We can now fit the job up as shown in Fig. 1, and we shall have a dead true flat surface, dead square with the lathe headstock mandrel, so that with taper shank drills carefully ground, and taper socket adapters, we can drill holes dead square and true with the surface against which the job rests.

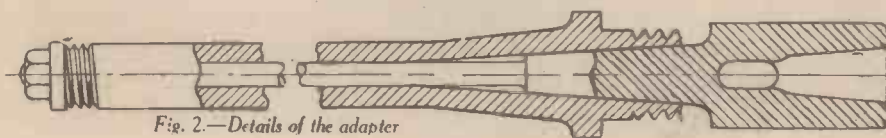

Fig. 2.—Details of the adapter





Two of the numerous applications of "black" light. On the left is shown a cleverly faked lily pond in what appears to be a Chinese setting, whilst on the right is shown how cinemas may overcome the problem of the black-out by "illuminating" the pay box

# Applications of "Black" Light

Special Mercury Lamps for the Production of Ultra-Violet Light  
 The Use of Fluorescent Materials for Display Work  
 Analysis Under "Black" Light

**W**HAT is generally referred to as black light, in non-technical circles, is not actually black, but ultra-violet. Even that statement is not quite true, because the ultra-violet rays produced by the special lamp bulbs available are mixed with a small proportion of visible light rays.

This "black" or ultra-violet light has a wide number of extremely interesting and valuable uses in everyday life. One of the most spectacular is for "illuminating" signs and such parts as the pay-box and doors of a theatre vestibule. It can also be used to make street refuges and traffic policemen visible during black-out. Other interesting uses are in the analysis of foods, the inspection of all kinds of materials, the detection of imitation precious stones, and of forgery and alteration of documents. It would be possible considerably to extend that list, but it is better first to see precisely how this "black" light is employed.

## Mercury-Discharge Lamp

The "light" is produced by a mercury-discharge lamp of which the principal parts are shown in an accompanying illustration. It will be seen that the filament of the ordinary electric light bulb is replaced by a quartz tube fitted with two tungsten electrodes. This tube is filled with a rare metallic gas, which contains a small amount of mercury. It will also be noticed that ordinary glass is not used for the outer bulb, nickel-iron glass being employed instead.

The reason for this is that ordinary glass is not completely transparent to the ultra-violet rays. The bulb used is coloured a deep violet and, therefore, "holds back" any visible light produced in the discharge tube.

In some respects, the mercury lamp can be compared with a neon lamp, for in both cases there is an electric discharge between two electrodes and through a gas. Another similarity is that both are normally used with a starting resistance, and that a choke is wired in series to regulate the current,

which varies from the moment the current is switched on until the time that a normal discharge occurs.

## Power-Factor Correction

Besides the regulating choke, it is generally desirable—and often essential under the rules of the electric-supply undertaking—that a condenser be used in conjunction with the choke to improve the power factor. Apart from these two items and the fact that it has a three-pin cap, the mercury-discharge lamp can be used in any ordinary A.C. supply circuit; it operates at any standard voltage, but cannot be used on D.C. The object of the three-pin cap is to prevent the lamp from being inadvertently fitted into an ordinary lamp holder not connected through the necessary choke.

## Wavelengths of Light

The wavelength of the light emitted by the lamp is between about 3,130 and 4,050 angstrom units, although by far the highest percentage of light (over 90 per cent.) is on the wavelength band between 3,650 and 3,663 angstrom units. An angstrom unit, by the way, is one hundred-millionth of a centimetre, and the range of wavelength covered by visible light—from violet to red—is 4,000 to 7,500 angstrom units.

Having gained some idea of the nature of black light, and of the manner in which it may be produced, it is possible to see how it is used for the purposes mentioned in the opening paragraph. It is not difficult

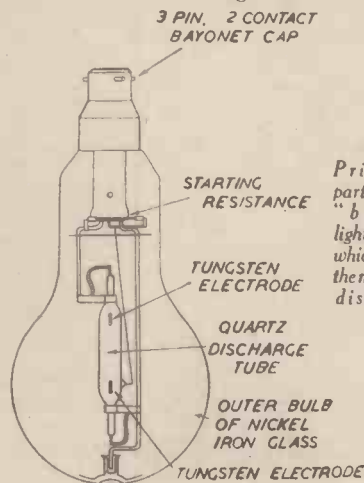

Principal parts of the "black light" lamp, which is of the mercury-discharge type

to appreciate that if the light emitted is invisible, its wavelength must be changed before the light can be appreciated by the human eye. And the method of changing the wavelength is by employing what is known as a fluorescent substance, from which the light can be reflected or re-emitted.

#### Fluorescent Materials

Most readers are familiar with luminescence and luminous paint, such as is used for treating the hands and figures of watches and clocks. This paint "stores" a certain amount of the light directed upon it during daylight, and gives out the light when placed in a dark place. Fluorescent substances are similar, except that they do not "store" light; instead, they are active only during the time that ultra-violet light is directed upon them. In other words, they are not visible in darkness until they "receive" ultra-violet rays from an external source. When such rays are directed on them, they appear to be brightly illuminated, despite the fact that the rays themselves cannot be seen.

It is now possible to obtain fluorescent materials in a wide variety of forms. Among the materials are paints, chalks, stage make-up, plastics, artificial flowers, and metal signs. In every case, they can be obtained in a range of colours; that is, their form is such that they appear in different colours while exposed to ultra-violet rays. In daylight they may appear



*A beautiful lily pond effect from a sheet of glass, a few bits of fluorescent material and "black" light*

to be a dirty brown. Butter can easily be differentiated from margarine, since under the rays it appears bright yellow compared with the pale mauve of margarine.

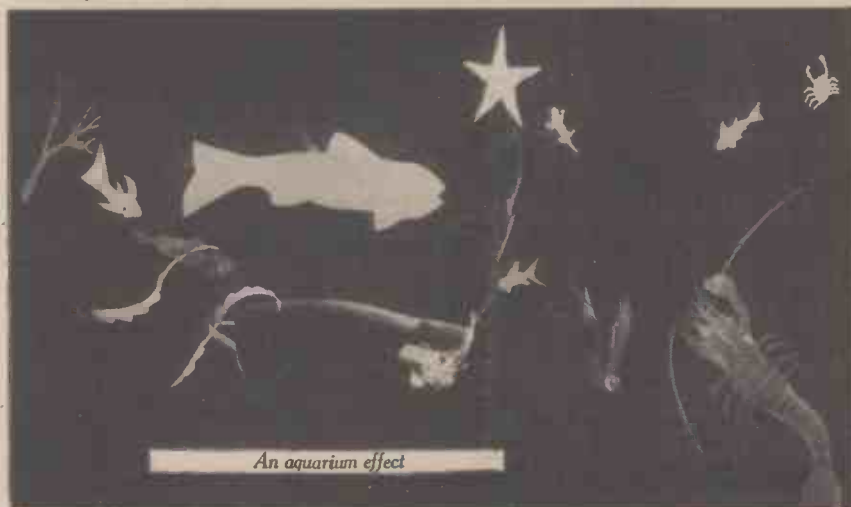

*An aquarium effect*

colourless or show only the colour of the material which has been treated.

#### An Illusion

It is sometimes disappointing to see the objects treated with the fluorescent colour in daylight. For example, a silk dress may appear to be beautifully coloured in, say, an attractive flowered design in black light, while when the ordinary lighting is switched on it is evident that the dress is a shabby and dirty white one, entirely devoid of decoration. This also applies to advertising signs and theatrical make-up.

It was mentioned above that black light can be used in chemical analysis. This is because many substances possess the property of fluorescence to at least a small degree, the extent varying with the condition and composition. It is known, for instance, that oils and greases are luminescent to a fairly high degree, whilst different kinds of bacteria luminesce in various ways.

As an instance of the use of ultra-violet rays for testing foodstuffs, it is of interest that a fresh egg will exhibit a red fluorescence, whilst one which is stale will appear

Precious stones and various other valuable substances can be checked for quality and even source of origin by examining them under black light. This form of lighting is also of great value in modern crime detection. Different inks, for instance, may appear to be exactly the same colour in daylight or ordinary artificial light, whereas under ultra-violet illumination they are entirely different. It is thus often an easy matter to ascertain that certain words on a manuscript or a text were written after the main part was prepared. Similarly alterations to old paintings can be detected, or new portions of paper skilfully attached to the old shown up clearly, although inspection in the ordinary way, even under a powerful microscope, does not reveal any difference. The latter is of importance to stamp collectors. Another way in which ultra-violet light is useful in philately is in the detection of such alterations as the removal of a post mark, or the forgery of overprinting.

One of the makers of mercury lamps produces a special cabinet for fluorescent analysis. This is complete with viewing window, the necessary lamp and control

gear, and is suitable for use in either ordinary daylight or in a darkened room.

#### Other Applications

It is impossible to mention, even briefly, all the uses of ultra-violet-ray inspection, but one use which has been developed by a commercial concern is for marking laundry. It is possible to put large number markings on the front of a shirt which are quite invisible in ordinary light, but which show up with great clarity when "black" lighting is used in the sorting department.

It will probably be remembered that stage "turns" have been given in which the whole of the stage is in darkness, but the artists wear clothes treated with fluorescent colours. The effect is at first mystifying and is very spectacular.

In this connection, the use of fluorescent paints for street signs, signs pointing to air-raid shelters, and to indicate road junctions and obstructions, provides a useful safety measure. Various experiments have also been carried out successfully in different parts of the country of providing point-duty policemen with fluorescent coats or arm-lets; ultra-violet light from an overhead mercury lamp makes them clearly visible.

#### The Lamps and Accessories

Mercury lamps produced by members of the Electric Lamp Manufacturers' Association (who supplied the photographs reproduced) are obtained in two wattage ratings, 80 and 125 watts, the actual consumption being slightly in excess of these figures. The lower-power lamp costs 40s., whilst the choke for use with it is priced at about 37s. 6d., and the condenser at about 10s. 6d. A suitable three-pin lamp holder costs roughly the same as the standard two-pin type. Either lamp has a usual average life of not less than 1,500 hours.

For efficient results, mercury lamps should be used with good reflectors of the spotlight type, such as those often used for shop-window illumination. Polished metal and silvered glass reflectors are fairly good, but reflectors made from chromium-plated steel show the highest efficiency.

It would not be possible to give a complete list of suppliers of fluorescent materials, but lamp manufacturers will be pleased to give details. Alternatively, readers may obtain particulars by writing to the Editor of this magazine and complying with the rules of our Advice Bureau.



*A further use for "black" light inside a theatre. The steps are outlined in fluorescent water colour paint*

# MASTERS OF MECHANICS

No. 57. A PIONEER WHO FAILED

*The Tragic Story of William Friese-Greene, Cinematograph Inventor And Pioneer of Moving Pictures In England*

**W**ILLIAM FRIESE-GREENE, like many another inventor, was apparently one of Fate's unfortunates. And even after his death, a certain amount of misfortune has dogged his memory, in that his name and achievements are nowadays becoming very little known, despite the fact that it was he who, to a very large extent, made commercial cinematography possible.

Yet, during his strenuous and peculiarly restless life-career, Friese-Greene experi-

*A modern cinema projection room, complete with cinema-television apparatus.*



enced one after another practically all the discouragements which have traditionally been heaped upon the heads of unfortunate inventors and pioneers of new notions. Poverty, ill-health, disappointments, bad luck, and even the experience of imprisonment all came to Friese-Greene in their turn, but neither separately nor together were these misfortunes able to abate his ardour or dim his vision in the cause of a project which he had made singularly his own.

#### Born in Bristol

William Friese-Greene was born in the city of Bristol on 7th September, 1855. He was educated at the Blue Coat School in that town, and—during his early teens—he became actively interested in the then rapidly growing science of photography. Chancing to pick up a friendship with one of the sons of Henry Fox Talbot, of Laycock Abbey, in Wiltshire, one of the earliest pioneers of photography in this country, Friese-Greene obtained from him some tuition in the photographic art and technique of the period. These amateur dabblings quickly grew into something more serious and they eventuated in Friese-

Greene becoming a professional photographer and setting up a studio in Bath, in which famed city he experienced a fair amount of success during those early days.

#### Magic "Lanterning"

After he had been in Bath a few years and was settling down to the career of a professional photographer, Friese-Greene happened to strike up a friendship with Arthur Roebuck Rudge, an individual who had made a special study of "magic lanterning," as the art of optical projection was often termed in those days. Rudge was gifted with inventive faculties. He had devised, some years previously, various forms of mechanical lantern slides which gave a semblance of crude motion when exhibited in the optical lantern, and, at the time of



*William Friese-Greene.*

ments, continuing them on his own individual lines. In 1885, Friese-Greene gave an exhibition of his mechanical lantern to the Photographic Society of Great Britain, the improved lantern being worked by means of turning a handle, whereby a photographic portrait of a human face was made to go through a series of different expressions.

About this time, Friese-Greene removed his professional photographic studio from Bath to London, setting up in the heart of the Metropolis and taking over a fashionable studio in Piccadilly. For a time, he was eminently successful in his new surroundings, but, probably owing to the fact that he was not able to settle to the humdrum of daily commercial routine, Friese-Greene bestowed more and more time on his inventive projects, and, incidentally, more and more of his hard-earned money on them. The result was, of course, that whilst Friese-Greene's projected "motion camera" was coming into being, his Piccadilly business began gradually to go out of existence. However, the process was a gradual one, and Friese-Greene "lasted" in Piccadilly for several years, before finally he relinquished his studio in that classic thoroughfare.

In 1888 he produced (and patented) a "motion camera" which took a series of instantaneous photographs on ribbons of sensitised paper of various lengths up to 50 feet. Each picture measured 2½-in. by 1¼-in., and the edge of the paper ribbon was perforated with circular sprocket holes which enabled the ribbon to be carried along in the camera by means of a claw movement.

#### First "Motion Camera"

This, Friese-Greene's first "motion camera," as he called it, was full of faults. Nevertheless, it was also replete with possibilities, and it quickly led to the making of a second instrument (patented in 1889) which employed a celluloid film, which its inventor had been able to obtain from one Alexander Parker, a pioneer Birmingham manufacturer of celluloid. This camera had two side-by-side lenses. It was so constructed that it could be employed as an ordinary stereoscope camera or as a single lens camera. The pictures which it took were about 3 inches square, and the celluloid film (accommodating the two side-

Friese-Greene's meeting with him, he was working on a device which he subsequently termed a "Bio-Phantoscope." This "Bio-Phantoscope" comprised a magic lantern which was equipped with a mechanism whereby a series of lantern slide photographs of various consecutive phases of movement could be projected on to the screen and thus give the illusion of actual movement.

Rudge's lantern device, which, popularly, he dubbed "Life in the Lantern," constituted one of the very earliest means of producing actual movement on a lantern screen by the use of photographic slides. Friese-Greene showed the greatest interest in it, and it was undoubtedly he who suggested to Rudge some of the improvements which were afterwards made to it. It was the "Bio-Phantoscope" which impelled Friese-Greene to devote his spare time (and afterwards his full time) energies to the then very formidable problem of reproducing movement on the lantern screen.

#### Rudge's Experiments

Friese-Greene first met Rudge in 1882, and the latter dying not long afterwards, Friese-Greene took over Rudge's experi-

by-side pictures) some 7 inches in width.

Exactly why Friese-Greene endeavoured to reproduce motion with the aid of such an inconveniently-sized film, and why he attempted, also, to introduce stereoscopic complications at the same time, we shall never, perhaps, know clearly. We do know, however, that this ungainly and primitive cinematograph camera took 10 pairs of stereoscope pictures every second, and that the film travelled through the camera mechanism at the rate of nearly 3 feet per second, which is an excessive velocity even in modern cinematographic apparatus.

Unlike the paper "film" which Friese-Greene had used in his first camera, the celluloid film was not perforated at its edges. It was fed through the camera by means of a lever movement which gripped the film at intervals. Film for about 300 consecutive exposures was accommodated on a spool fixed within the camera, and in travelling before the camera lens, the portion of the film which was immediately behind the lens was momentarily arrested and held flat by means of a plate so that that area of film remained stationary and reasonably flat during the brief period of its exposure.

#### Patent Granted

The patent on this now historic camera was granted on 1st June, 1889 in the names of William Friese-Greene and Mortimer Evans, an engineer, who had become interested to some extent in the project. The patent was entitled "Camera for taking pictures at a rapid rate," no implication of its ultimate aim in the screen reproduction of motion being indicated.

With this camera, Friese-Greene essayed to take some pictures of the London traffic at Hyde Park Corner in the summer of 1889. He subsequently exhibited them on a miniature screen in the window of his Piccadilly shop. All the reward, however, which this, the first public exhibition of "animated pictures" in England, received was a warning from the police to Friese-Greene to the effect that he would be prosecuted if he continued to cause obstructions in the form of the crowds who congregated before his shop window to view the wonderful animated scenes of traffic. The official mind, indeed, has ever exerted scant sympathy over novel projects and new departures.

Suppressed by the police, Friese-Greene's exhibitions of living pictures quickly became forgotten. Even Mortimer Evans, Friese-Greene's fellow patentee, rapidly lost interest in the possibility of commercialising motion photography by means of a mechanical camera taking the newly-manufactured celluloid film, and it was not long before he allowed Friese-Greene to acquire his share of the patent for the sum of £200.

#### Picture Exhibition

In the following year (1890) history records that Friese-Greene gave an exhibition of his pictures before the Royal Photographic Convention at Chester. Since Edison's earliest "peep-show" cinematograph did not materialise until 1891, it is clearly evident that the Englishman, Friese-Greene, amply forestalled the more famous American inventor in the matter of the primitive cinematograph.

Things, however, were not going well with Friese-Greene at this time. His regular photographic business, having been neglected, was going down, and he was beginning to find himself hard pressed for money.

In vain did the inventor strive to convince people that his camera had within it inherent commercial possibilities. He endeavoured to get the British military authorities interested in the camera, but

although the War Office seemed to evince some slight curiosity in the device, nothing practical came of it. No one, indeed, appeared to offer the slightest interest in the machine. Friese-Greene wrote to Edison in America, offering to co-operate with him, but it is to be feared that the American inventor was, at that time, far too greatly engaged in other of his multifarious notions to take much notice of Friese-Greene's personal appeal.

#### Surrounded by Debt

Thus it was that the British inventor, now almost despairing of the success of his invention, relinquished it for a time, and endeavoured to re-engage himself in the ordinary routine of business. But it was a vain attempt. For years, Friese-Greene had poured out money on his projects, and now he found himself surrounded by petty debtors and harassed by creditors. He settled with them honourably as far as he could, but poverty eventually so greatly overwhelmed him that in the February of 1891, his home was broken up and sold, together with most of his apparatus, in order to pay off his debts. Later, Friese-Greene was incarcerated in Brixton Gaol on account of certain debts which he had been unable to meet.

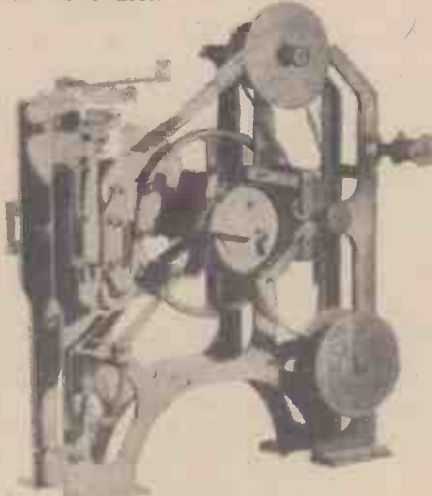

One of the earliest cinema projector mechanisms made in England. It was used for the exhibition of moving pictures before King Edward VII (then Prince of Wales) in Buckingham Palace in 1897.

The amount of hope which wells up within the breast of the average inventor is amazing. Friese-Greene was no exception to this generalisation, for, after his release from the debtors' prison, he again turned his attention to motion picture matters and at once endeavoured to rebuild his fortunes.

At this time, another British cinema pioneer, Robert Paul, was working on the problem of photographic motion, and he had equipped a studio outside London for the taking of short films. Paul had interested himself in the colouring of his films, to which end he had engaged a small staff of artists expressly for the purpose of colouring up each individual "frame" or unit-picture of his films. The work, naturally, was slow, expensive and unsatisfactory. Friese-Greene, however, working in conjunction with Paul, devised a method utilising a three-colour photographic process by means of which the scene or subject was photographed on motion-picture film by three separate cameras equipped with red, green and violet light-filters respectively. In order to show such a film in "natural colours" on a screen, three cinema projectors were operated, each being equipped with one of

the colour filters. Thus, three projected pictures were superimposed upon the screen and a fair approximation to natural colour images resulted.

#### Two-Colour Process

Friese-Greene subsequently (1898) devised a two-colour process of cinema photography using a blue-green and a red-orange filter. It took six or seven years, however, to commercialise this process in the final form of photographing the subject through the pair of colour filters revolving in front of the camera lens, and, subsequently of projecting them through a similar pair of revolving colour filters. This system, however, constituted the origin of the once well-known "Kinemacolor" system of motion-picture photography in natural colours, and even nowadays some screen colour systems are founded upon this principle.

Seeing that others had taken from him his fundamental idea of the motion picture camera utilising celluloid film, Friese-Greene endeavoured to develop other ideas connected with cinematographic projection and photography. He devised various stereoscopic cinema cameras. None of these, however, became commercially successful—and, indeed, to this day, the problem of stereoscopic vision on the motion-picture screen still remains unsolved.

Probably Friese-Greene suffered from an overplus of mechanical ideas connected with the early cinematograph, for it would seem that no sooner had he partially solved one problem than he started off on another one, leaving the former at an immature stage.

Domestic worries sorely tried Friese-Greene. At one period about this time, he and his family very nearly starved, and for years they were in want of the ordinary necessities of life.

In later years, however, Friese-Greene obtained employment with a colour photographic concern. Nevertheless, as a pioneer and an inventor, and as an individual upon much of whose work was based the huge cinematograph industry which had then arisen Friese-Greene remained unacknowledged, a type of injustice which particularly rankled with him.

#### Ill-health

For Friese-Greene, there was only ill-health, penury and a dogged existence which was to last right through the years of the Great War and up to 1921, on the 5th May in which year he attended a meeting in London connected with the cinema industry. Almost unknown as a pioneer of the industry and as an early inventor of cinematographic apparatus, Friese-Greene, from his seat at the back of the room, boldly addressed the meeting, making certain relevant observations as to the state of the British cinema industry. His speech was applauded. Some of those present even remembered him in the earlier days of the industry.

And then came tragedy. For no sooner had Friese-Greene regained his seat after his speech than he collapsed and died. It was indeed an abrupt passing-out for the inventor who had led a lifetime charged almost continually with vexation and disappointment. Yet, strangely enough, his sudden decease led to a general acknowledgment of his claims to recognition as the pioneer of motion pictures in Britain.

The pity of it, though, was that such recognition came too late, for a Friese-Greene not continually harassed by financial worry might well have provided the means to establish the British film industry in the face of American competition long before the many belated efforts were actually made in this direction.

# Our Busy Inventors

## Baby Cabinet

THE cradle during some hundreds of years has undergone comparatively little change. In the Victorian era it appeared to be a juvenile relative of the rocking chair, in which our forbears move themselves without making any progress. But I believe that authorities on child welfare look askance at the wobbling method of lulling the baby to sleep. The cradle has sloughed its rockers.

The latest thing in cradles has been devised by a Parisian and his wife, and they have applied for a patent in this country. To them the infant world is indebted for the inception of a cradle which is styled a "self-heater." The aim of this slumber cabinet for the very young is to enable nursing infants to be reared under conditions which make for ideal bodily development. The characteristic feature of the device is that clothing is dispensed with. This will relieve the child of the irritating necessity of much dressing and undressing. It will also save the mother a considerable amount of work and trial of patience.

No child enjoys the constriction imposed by its garments. It loves the freedom of its limbs. Does not the young hopeful kick off its little shoes? In a parenthesis I may remark that many youngsters prefer to go barefoot. In Scotland one used to see boys and girls voluntarily without shoes and stockings. I have known of a sturdy little Scot who would leave home in the morning having on the boots he was compelled to wear. But, when out of sight of his home, he would remove them and hide them in a hedge, donning his footwear upon his return.

## Self-Heating Cradle

THE new cradle is a hollow body of oval shape. It is made of insulating material, such as wood fibre, of moderate thickness. On the bottom of the cradle rests a flat vessel made of aluminium. An orifice, closed by a plug, permits the vessel to be filled with water by means of a funnel. At the end of the vessel is an emptying tap. On the vessel rests a receptacle in the form of a dish covered by a hammock of coarse cloth fixed round its edges by buttons and eyelets. At the upper part of the cradle are inserted dry and wet bulb thermometers, and there are also provided apertures for ventilation.

There is introduced into the vessel a sufficient quantity of hot water to raise the temperature of the cradle, which according to the age of the infant, should vary between 28° and 37° C. approximately.

The desired temperature having been reached, the infant is placed naked in the hammock, and a collar is fastened round its neck. When the child is older, the natural heat which it emits is amply sufficient to maintain the temperature of the cradle at a suitable degree. This justifies the name "self-heater" cradle.

In hot countries, cold water must be introduced into the vessel. By comparing a dry and a wet thermometer, it is possible to find the humidity of the atmosphere of the cradle.

If considered advisable, the heat of this cradle cabinet could be increased to such an extent as to provide the effect of a Turkish bath.

## By "Dynamo"

When the baby is suckled, it is taken from the cradle and put into a woollen sack.

## Barking And Crying

THERE are two sounds which are most annoying. One is the persistent barking of a dog; the other is the continual bad language of a child that cannot talk. That statement is not so absurd as is at first apparent. Tennyson affirmed that the only language of a baby is a cry. Now, in the case of a barking dog and a crying child there is a cause. As regards a baby, it probably means that the infant is not being properly treated with respect to food or some other circumstance. Its cry is a legitimate protest, and Dame Nature has arranged that the protest shall impress its elders. For their own comfort as well as that of their offspring, they make a supreme effort to find a remedy for the evil.

It is possible that the hygienic sleeping cabinet I have described will give His Majesty the Baby just that freedom of limb and congenial heat which will keep him in a continual state of good temper.

## New Aeroplane Parachute

THE parachute is now very much in the limelight. It has to be reckoned with as a factor in warfare. Therefore any device which enhances its efficiency demands serious attention. An inventor, who has devoted his thought to this subject, states that the ideal aeroplane parachute must satisfy three main conditions.

Firstly, its weight and volume must be reduced to a minimum.

The information on this page is specially supplied to "Practical Mechanics" by Messrs. Hughes & Young Est. 1829, Patent Agents of 9 Warwick Court, High Holborn, London, W.C.1, who will be pleased to send readers mentioning this paper, free of charge, a copy of their handbook, "How to Patent an Invention."

Secondly, a suitable speed of descent must be possible so that the ground may be reached without too violent a shock to the parachutist.

Thirdly, a minimum opening stress is necessary to avoid too great a shock at the moment of opening, and to allow the use of lighter and less cumbersome materials, while maintaining the same degree of safety.

The inventor in question has produced an apparatus offering a reduced bearing surface, while keeping a suitable descent speed, and having an adjustable opening stress, so as not to inconvenience the user of the parachute.

The contrivance comprises a composite sail made up of a combination of elements of porous and impervious surfaces. In order to facilitate the construction of such an apparatus with an equally divided composite sail, the whole sail is built of a porous tissue—the tissue supporting the stress—on which the impervious parts are afterwards applied at the places designed.

If this parachute really is what its inventor aims at, it should ensure a gradual and graceful descent from the clouds.

## Vivid Trade Names

THE American is notorious for vivid language. His invention, as regards

pithy expressions, is at times striking. Here are some scintillating examples culled from the list of very recent trade names submitted to the United States Patent Office. "Nicegoon" is appositely applied to a liquid cleaner for floor surfaces. Let us hope that it will obviate the involuntary tobogganing which is the usual effect of a polished floor. In the class devoted to ardent spirits appears the word "Oxogin" with the slogan, "gives life to your party." The class headed "Prints and Publications" contains a number of original captions for magazine columns. The following are examples:

"Funny Coincidence Department,"  
 "Brotherhood of Man Department,"  
 "Department of Utter Confusion,"  
 "Department of Understatement," and  
 "Infatuation with Sound of Own Words Department."

A further trade name for which registration has been applied for in the United States relating to cotton goods, is the familiar phrase "Confucius Say." Incidentally, it is interesting to note that the name "Confucius" is the Latinised form of the philosopher's Chinese name which was "K'ung-fu-tze." It was coined by the Jesuit fathers who in the seventeenth and eighteenth centuries fearlessly penetrated to the Far East.

By the way, Confucius did say one thing which proves that he did not claim to be an inventor as far as his philosophy is concerned. The wise Chinaman spake words to this effect (I quote from memory):

"I am not a creator. I am a transmitter. I believe in the ancient wisdom."

Before leaving the subject of trade-marks, I note that application has been made to register in this country the popular term "Blue Pencil" in relation to the products of an English winery.

## Gas Masks And Glasses

SPECTACLES to be worn with the standard civilian gas mask are the subject of a recent application for a patent in this country. If I remember rightly, the wearer of spectacles has previously been catered for in connection with a gas mask. But the new contrivance arranges for the glasses to be worn outside the mask. In this instance, the spectacle frame has looped supports at its top and bottom by which it is held in position on the mask. The frame is formed at the top with a stem terminating in two angled pieces to which the upper support is attached. As a result, the frame is held in correct alignment with the eye.

## Armour For Footballers

IN America, I understand, they play a rougher type of football than is seen on our side of the Atlantic. This explains why some inventor in the United States has patented there an equipment to protect the bodies of football players. The armour is composed of two sections. Each section comprises a body-piece of stiff resilient material to envelope a part of the wearer's torso. It also includes an arm-guard of rigid material swivelled front and rear to the body-piece, and a ringed shoulder cap which overlies and rests free upon the arm-guard. Protected with this armour the ardent player can rush into the field accoutred like a chevalier in a tournament.

# MINESWEEPERS AT

BY COMMANDER



The crew on board a minesweeper lowering a paravane into the water

**M**INESWEEPING is certainly the most unceasing, and is probably the most dangerous task which the Navy is called upon to fulfil in time of war.

Every day the channels leading into our numerous commercial and naval ports and a broad channel right round our long coast-line must be swept with care, in case some enemy submarine or other minelayer has dumped, unobserved, its deadly cargo in the path of unsuspecting ships.

In addition to this routine sweeping, there are demands, from time to time, for the sweeping of safe channels for our warships operating in the open sea or off the enemy coast in areas where mines are known, or are suspected, to have been laid.

Occasionally, also, it is necessary to sweep such channels through our own minefields, or to remove one of our minefields after it has served some temporary purpose and has become a nuisance to us.

### An Enormous Task

Finally, of course, there is the enormous task, when the war is ended, of sweeping up what remains of the minefields laid by both belligerents.

The magnitude of this task can perhaps be appreciated when it is realised that in the last war some 172,000 mines were laid by the Allies and some 44,000 by the Germans, and that a large proportion of these had to be cleared at some time or another by the minesweepers of one or the other side.

Some idea of the risks involved may be gained by a study of our losses, which averaged over one minesweeper a week for the whole period of four years, three months

and seven days, numbering 246 in all. These losses were heaviest, of course, during the earlier days, when we lost, on an average, one minesweeper for every two mines swept up, and were subsequently, as experience was gained, reduced until, towards the end of the war, the average was one for every eighty mines swept up.

In the present war, therefore, we may reckon on having started with the average approximately where it was when we left off, which is already a matter for concern since whenever a minesweeper is blown up about half her crew is lost. Air attack has, however, introduced a new risk which will doubtless offset some of the advantage which we have gained.

### Classes of Minesweeper

Minesweepers are divided into three classes :

(1) *Routine Sweepers.*—These are usually fishing trawlers and herring drifters, which require but little conversion to fit them for sweeping mines, and whose excellent sea-keeping qualities enable them to perform their duties in almost any weather.

Their function is to search for and locate minefields; not, as a rule, to sweep them up, a task for which their comparatively deep draught renders them unsuitable.

When they find a mine, they at once

Minesweeping Consists of "Combing" the Seas with a "Sweep" which Contacts with and Cuts the Mooring Rope of the Mine. The Mine, Having Positive Buoyancy, then Floats to the Surface, where it is Destroyed or Rendered Harmless

mark the spot where it was found with a dan buoy (a cylindrical float with a flag) and report by signal to their base for the Clearance Sweepers to come out. While waiting for the latter to arrive on the scene, they continue their search with caution, attempting to locate the limits of the field which must be swept.

(2) *Clearance Sweepers.*—These are shallow-draught vessels of various types; often enough they are paddle-steamers which in peace time ply on pleasure trips from seaside piers.

Their function is to come out when mines have been found by the routine sweepers, or by some luckless ship which has run on one of them, and to sweep thoroughly a wide area over which they may have been laid in that vicinity.

Their shallow draught enables them to do this with comparative impunity, as mines are usually set to remain at a depth where they will inflict the maximum damage on ships of large tonnage.

(3) *Fleet Sweepers.*—These are either Sloops, specially constructed for the pur-

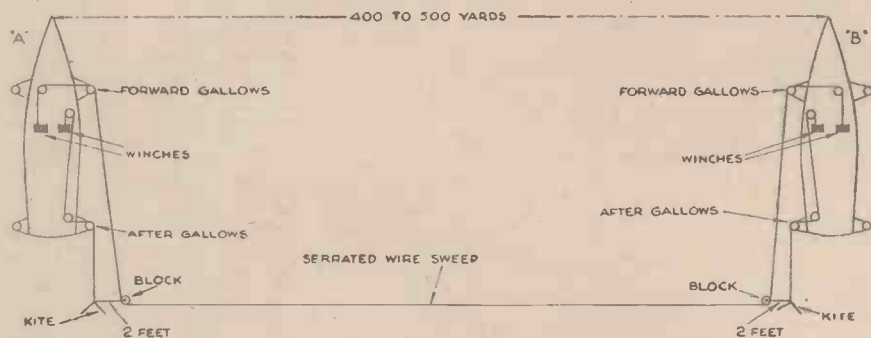

Fig. 1.—Showing how minesweeping is done by a pair of minesweepers working together

# WORK

EDGAR P. YOUNG, R.N.  
(RETIRED)

pose, or fast railway steamers, converted as necessary for sweeping mines.

Their function is to sweep at comparatively high speed ahead of the fleet or of a convoy, in waters where routine sweeping is impossible or has not recently been carried out.

They also are, as a rule, vessels of shallow draught, in order that they may stand more chance of being able to pass unharmed over the mines which have been laid deep to catch the heavier ships which follow.

## Methods of Minesweeping

A mine is usually a spherical or cylindrical object with positive buoyancy, secured by a steel-wire "mooring rope" to a heavy "sinker" which lies on the bottom of the sea.

An automatic device within the mine controls the length to which the mooring rope runs out, in such a way that the mine is usually kept far enough below the surface to allow shallow-draught vessels to pass

Fig. 2.—1. Mine in its normal position. 2. The sweep catches the mooring rope and, sweeping forward, draws the mine downwards and forwards. 3. The serrated wire sweep cuts the mooring rope of the mine, releasing it from its sinker. The mine, having positive buoyancy, rises towards the surface. 4. The mine on the surface where it is riddled with rifle bullets. 5. It sinks and lies harmless on the sea bed

shallow-draught vessels. In places where the range of the tide is very great, it may even happen that, at low water, the mine is actually on the surface.

Another automatic device ensures, or should, in accordance with international law, ensure, that the mine becomes "safe" at once in the event of its breaking adrift from its sinker. This device does not always operate satisfactorily, however, especially if the mine has been immersed for a long

it would, in any case, represent some danger to smaller craft, it is then riddled with rifle or machine-gun bullets until it sinks to the bottom.

Two alternative methods are commonly used both by routine sweepers and by clearance sweepers, whether for locating mines or for sweeping up mines which have been located.

## Two Minesweepers at Work

The first of these necessitates the use of a pair of minesweepers, as shown in Figs. 1 and 2, towing between them a serrated wire sweep, 400 to 500 yards in length.

In order to keep the sweep at such a depth below the surface as to ensure its coming in contact with the mooring rope of the mine, it is passed through a block secured to a device called a "kite," which is towed by each of the sweepers over its inner quarter. The depth at which the "kite" is towed can be adjusted, as shown in Fig. 1.

The sweep is towed through the water. When it comes in contact with the mooring wire of a mine, the latter is drawn forwards in the direction in which the sweepers are moving, and, in the process, slides along the serrated wire of the sweep and is severed. The mine is thus released and floats to the surface, where it can be sunk by rifle or machine-gun fire from one or the other of the sweepers.

It may happen, however, that the sweep fails to cut through the mooring rope of the mine before the mine is drawn over to and strikes one of the "kites." If this occurs, the mine is often detonated by the "kite" and its explosion may severely damage or even destroy the sweeper to which that "kite" is attached.

The greater risk, especially when the

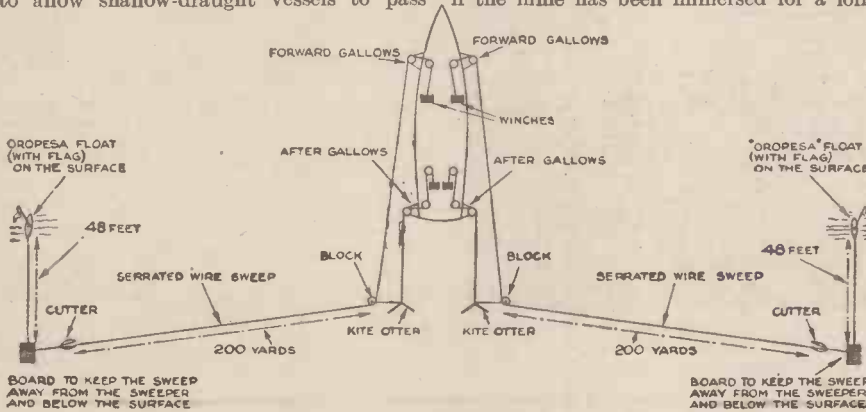
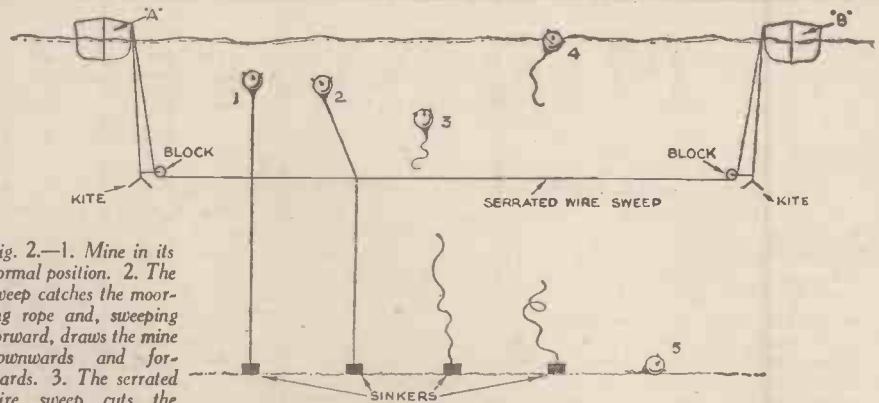

Fig. 3.—Showing a minesweeper with an "Oropesa" sweep out on either side (as a rule only one is used at a time)

over it, but to make contact well below the water-line with the hull of any deep-draught vessel.

At a given state of the tide, therefore, usually at high water, a shallow-draught minesweeper can pass over the mine unharmed. At any lower state of the tide, however, the mine floats nearer to the surface, and becomes a menace even to

time. Minesweeping consists of "combing" the seas with a "sweep" which contacts with, and cuts the mooring rope of the mine. The mine, having positive buoyancy, then floats up to the surface, where it can be spotted. It should, by the same process, be rendered "safe," but, because, as has been said above, the safety device is unreliable, and because

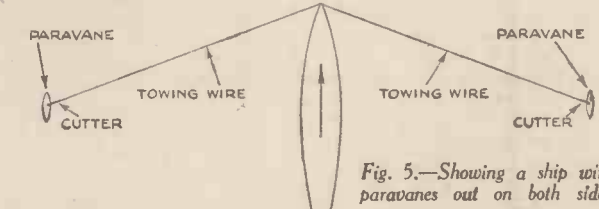
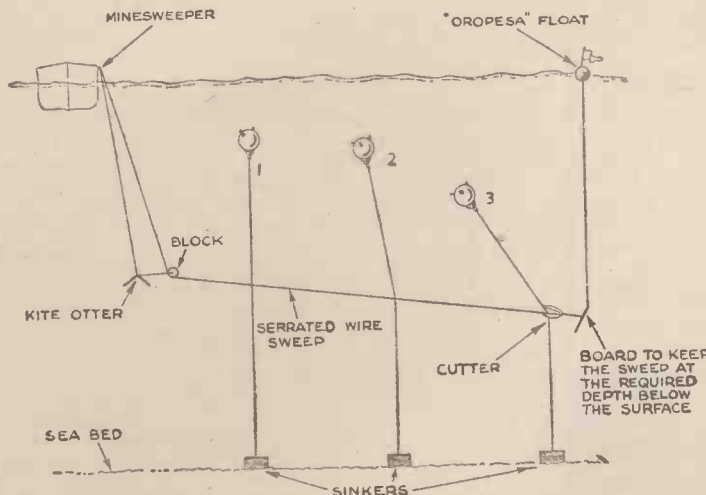

Fig. 4.—(Left) Showing in cross section how a minesweeper operates with one "Oropesa" sweep. 1. Mine in its normal position. 2. The sweep has caught the mooring rope of the mine, but has failed to sever it. 3. The mooring rope of the mine, sliding along the sweep, and perhaps being partially severed in the process, is just passing into the jaws of the cutter, which should sever it and re-lease the mine from the sinker. The mine is then destroyed as mentioned in Fig. 2

sweeper is a trawler, which draws 13½ feet, or more, is that the sweeper itself may come in contact with one of the mines. When this happens, since mines are designed to destroy a battleship, there is not much left of the unfortunate little trawler.

### Another Method

The other method, which is more commonly used to-day because it can be carried out by a single sweeper and because it is safer, is by the use of the "Oropesa" float.

This float, which is named after the minesweeper by which its experimental trials were carried out during the last war, is a torpedo-shaped float with a flag to make its position more visible from a distance. To it, or rather, as is shown in Figs. 3 and 4, to a board attached to it, is secured one end of the sweep, the other end being of course, on board the sweeper.

The board referred to is weighted, and serves to keep the sweep at the required depth below the surface. By taking the angle of least resistance to its passage through the water, it also keeps the outer end of the sweep extended away from the sweeper.

The ship's end of the sweep is kept at the required depth below the surface by a modified type of "kite," known as a "kite otter," as shown in the diagrams.

### Cutting Power

Owing to the fact that there is no actual forwards pull on the outer end of the sweep, special provision must be made to increase the cutting power of the sweep. As can be seen in the diagrams, the serrated wire sweep terminates at its outer end in a cutter, into which the mine's mooring rope eventually slides, if it has not been cut through by the sweep, and by which it should be finally severed.

Fig. 3 shows a minesweeper with "Oropesa" floats out on both sides, but as a rule this method of sweeping is employed on one side only, either side being equally suitable.

The process by which the mine is swept is exactly the same as when two sweepers are working together, but the risk of damage being done to the minesweeper is reduced, owing to the fact that the mine slides away from the sweeper and if it strikes anything before its mooring rope is severed it strikes the board beneath the "Oropesa" float.

### The "Oropesa" Float

The risk run by the minesweeper is still further reduced by the use of the "Oropesa" float in cases where a minefield whose confines are fairly definitely located is being cleared. In such cases, it is possible for the sweeper to steam along outside of and parallel to the edge of the minefield, with its "Oropesa" float alone exposed to the risk of passing through unswept water. Where two minesweepers are working together in the older way, one of them must, of course, have the unpleasant station within the minefield which is being cleared.

Neither of the methods which have been described can be used, however, for sweeping at high speed, nor are suitable, therefore, for use by fleet sweepers. These last employ a high-speed sweep, as shown in Figs. 5 and 6.

The high-speed sweep is towed from the bows, instead of from the stern of the sweeper, thus protecting it to a very considerable extent. This is of great advantage, because fleet sweepers have often to work in waters where no preliminary search for mines can be carried out.

### The Paravane

The sweep consists of paravanes, which are towed on both bows of the sweeper, at the end of a specially strong, light wire sweep, or "towing wire."

The paravane is a torpedo-shaped buoyant metal object with a metal plane

at right-angles to its length which is weighted at one end and is made buoyant at the other. The plane serves to incline the paravane on one side, so that, when towed forwards, it tends to run away from the ship which tows it.

Within the body of the paravane is a hydrostatic valve, which controls a horizontal rudder according as the pressure of the water on it (due to its depth below the surface) is smaller or greater than that set on it, and which thus maintains the paravane (and the outer end of the sweep) at any required depth below the surface.

The inner end of the sweep (towing wire) passes through a "towing shoe," which fits over the stem of the sweeper. This "towing shoe" is raised out of the water when the paravanes are not in use, and is lowered to the forefoot (or lowest part of the stem) when the paravanes are running clear of the sweeper. It is raised again when it is desired to take in the paravanes, in order that the towing wire may be caught in a snatch-hook attached to the wire which is used for hauling in and hoisting the paravane.

is thus released from its sinker, after having been carried well clear of the sweeper, and floats up to the surface, where it can be riddled with bullet holes until it sinks.

Paravanes can be, and are used by all classes of ships as a safety device against mines, and as such are extremely effective. Unless the mine comes in contact with the stem of the ship (which is very improbable), or the after part of the ship, in turning, passes through water which has not been swept by the paravane towing wire (which is only slightly less improbable), a ship towing paravanes cannot be mined.

### Sweeping Magnetic Mines

The sweeping of magnetic mines cannot be carried out satisfactorily or with any degree of safety by any of the methods which have been described. Indeed it is usually more easy and less dangerous to explode such mines than to sweep them up, and very often, since some types of magnetic mine have no mooring rope, but merely lie on the bottom, there is no practicable manner in which they can be swept.

For reasons of secrecy it is not permissible

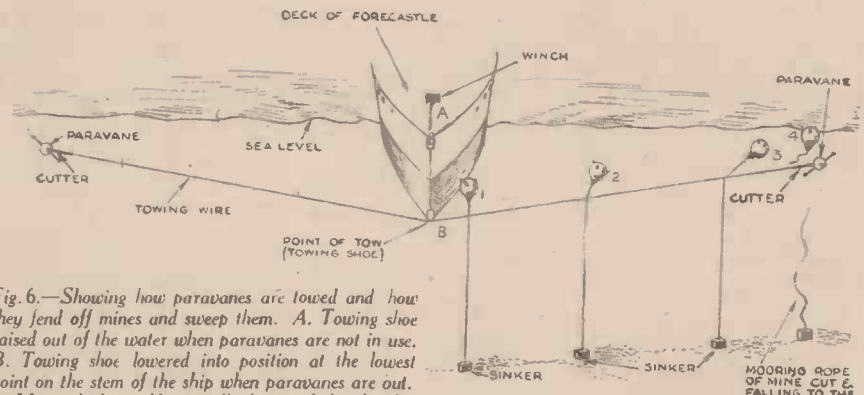

Fig. 6.—Showing how paravanes are towed and how they fend off mines and sweep them. A. Towing shoe raised out of the water when paravanes are not in use. B. Towing shoe lowered into position at the lowest point on the stem of the ship when paravanes are out. 1. Mine which would normally be struck by the ship and exploded is fended off the swell of her bows by the paravane towing wire which fouls its mooring rope. 2. Mooring rope of the mine slides along the paravane towing wire. 3. The mine being drawn away from the ship. 4. Mooring rope of the mine slides into the cutter on the paravane and is cut. The mine then rises to the surface and is destroyed.

### Paravane Chains

As an alternative to the "towing shoe," the "point of tow" of the paravanes may be attached to "paravane chains," which pass through special holes in the forefoot of the sweeper and which can be hove up or down by means of a capstan.

When not in use, the paravanes are carried on special "paravane davits" or, alternatively, are stowed on special slips. In time of war, they are kept constantly ready for use, with their towing wires, attached to the point of tow, coiled up and secured on the fore-castle.

When required for sweeping purposes, they are lowered almost into the water and then slipped, after which they dive and run out at an angle away from the sweeper. As soon as it is seen that they are running correctly, the point of tow is lowered and all is then ready for sweeping.

### How the Sweeping is Effected

Fig. 6 shows how the sweeping is effected. Unless, by bad luck, the mine comes in direct contact with the stem of the sweeper—in which case, of course, it blows the latter to pieces, it is washed to one side by the bow wave and its mooring rope is caught by the paravane towing wire or sweep. As the sweeper moves forwards with the paravane towing wires inclining slightly backwards, the mine's mooring rope slides along the latter until it passes into the jaws of a cutter on the paravane and is severed. The mine

to describe how they are dealt with, but doubtless many readers will exercise their ingenuity in devising means whereby this may be done with the minimum of risk to those who do it.

## VERSATILE USES OF NYLON

FROM parachutes to toothbrush bristles seems a far cry, yet nylon, the remarkable new raw material, can be used for the manufacture of both. In the autumn three factories are to begin production of nylon thread which will be used by the R.A.F. for parachute fabric, balloon "silk" and aircraft construction.

Nylon is stronger and more elastic than silk, is not affected by many everyday chemicals, and will not mildew. It can be blown into filaments as fine as a spider's web, formed into thin bristles or thick rods, and into sheets. Women can wear it in the form of stockings and fishermen have used it for lines. About the middle of June it will be on sale in this country as tooth-brushes.

Nylon bristles are better than hog bristles and absorb only one-fifth as much moisture. Its toughness is such that bristles do not break off or split. Owing to its smooth hygienic surface, nylon is cleaner and not susceptible to bacterial attack.



# Facts About Metals

(Continued from page 375 of May issue)

**Iridium Sponge.**—A spongy form of metallic iridium prepared by strongly heating ammonium chloroiridates. Similar to Platinum Sponge (which see).

**Iron.**—Metallic element. Chemical symbol, Fe (from the Latin *ferrum*). At. No. 26; At. Wt. 56; M.P. 1,530° C.; B.P. 2,450° C.; Sp. Grav. 7.8; Sp. Ht. .111641; Coef. Exp. .00001123; Therm. Cond. (Silver=100) 11.9; Elec. Cond. at 0° C. (Mercury=1) 9.68. (The foregoing data are for pure metallic iron only.)

Iron is the most abundant and useful of metals. It has been known from prehistoric times, and in its various forms, such as cast iron, wrought iron, steel, and alloy steels, it is the metal upon which civilisation has been built up.

**Occurrence:** Iron occurs in enormous quantities in Red Haematite or Specular Iron Ore,  $Fe_2O_3$ ; Brown Haematite,  $2Fe_2O_3 \cdot 3H_2O$ ; Magnetic Iron Ore (Lodestone),  $Fe_3O_4$ , and Spathic Iron Ore,  $FeCO_3$ . It also occurs in small amounts in the free state. It is frequently present in large amounts in meteorites.

Pure iron is a white, lustrous metal, which is capable of taking a high polish. In damp air it soon rusts. It is more difficult of fuse than wrought iron (the purest commercial form of iron), but at red heat, it softens and can be readily welded. Perfectly pure iron is useless for industrial purposes, and the physical properties usually associated with iron are, in reality, those of iron admixed with some definite type of impurity, such as carbon. These various types of iron—*Pig Iron, Cast Iron, etc.*—should be referred to under their separate headings. Iron is the most magnetic of metals. The metal is acted upon by most acids, but in nitric acid assumes an inert or "passive" condition.

**Iron Amalgam.**—It is doubtful if true iron amalgam exists. A compound said to be iron amalgam is prepared by grinding 1 part of finely divided iron powder with 2 parts of mercury chloride and 2 parts of water, adding, also, a few drops of metallic mercury. The product takes the form of a greyish, metallic-looking powder.

**Izod Test.**—A standard test of a metal's resistance to impact. The test-piece of metal (a square bar of 1 cm. side) has a notch in it of 2 mm. depth. The sides of the metal piece have an angle of 45° and the base of the piece forms a rounded groove of .25 mm. radius. This is held in a vice which forms part of the testing machine, and it is struck with a pendulum-like hammer operating from a given distance. The force required to break the metal is then determined and is expressed in foot-pounds of energy. A good steel gives an Izod number of about 45 foot-pounds.

## K

**K.S. Magnet Steel.**—A hard steel, difficult to work. It contains 35% of cobalt and has great magnetic retentivity. It is named after Baron K. Sumitomo, a Japanese.

**K. S. Piston Alloy.**—An aluminium piston alloy made by K. Schmidt, of Germany, from whose initial letters it derives its name. It has a Brinell Hardness of 120-140,

## LIST OF ABBREVIATIONS

The following abbreviations are used throughout this Dictionary:

At. No. . . . .	Atomic Number
At. Wt. . . . .	Atomic Weight
M.P. . . . .	Melting Point
B.P. . . . .	Boiling Point
Sp. Grav. . . . .	Specific Gravity
Sp. Ht. . . . .	Specific Heat
Coef. Exp. . . . .	Coefficient of Expansion
Therm. Cond. . . . .	Thermal conductivity
Elec. Cond. . . . .	Electrical conductivity

and a tensile strength (when heat-treated) of about 40,000 lb. per sq. in. Composition: silicon, 12%; copper, 4.5%; magnesium, .7%; manganese, 1.2%; nickel, 1.5%—remainder aluminium.

## L

**Lanthanum.**—Metallic element.—Chemical symbol, La; At. No. 57; At. Wt. 139; M.P. 826° C.; Sp. Grav. 6.1598; Sp. Ht. .04485.

Discovered in 1839 by Mosander, who named it from the Greek, *lanthanein*, to be concealed, in reference to the difficult task of elucidating its nature.

Lanthanum is one of the rare earth metals. It occurs in the ores, Cerite, Orthite and Gadolinite. Also in Lanthanite, an American ore.

Pure metallic lanthanum is rare. It is a white metal, fairly malleable and ductile. It tarnishes rapidly even in dry air, and when heated in air to 445° C. it takes fire and burns, giving a mixture of lanthanum oxide and lanthanum nitride. In moist air, it speedily becomes coated with white crusts of lanthanum hydroxide. It decomposes water, with the evolution of hydrogen and the formation of lanthanum hydroxide: It is easily dissolved by acids.

One alloy of lanthanum with aluminium, of the composition,  $LaAl$ , does not decompose water, and, moreover, this alloy is stable in air and highly resistant to acids. Its iron alloys are exceedingly hard.

On account of the rarity of the metal, lanthanum has no uses at present. It is, however, a metal with decided "possibilities."

**Lautal.**—A modern aluminium alloy of German origin. Composition: copper, 4.7%; manganese, 1.5%; silicon, 1.2%; remainder aluminium. When well worked and heat-treated, this alloy gives a tensile strength of 25 tons per sq. in. Much used in present-day aero work.

**Lead.**—Metallic element.—Chemical symbol, Pb (from the Latin *plumbum*). At. No. 82; At. Wt. 207; M.P. 326° C.; B.P. 1525° C.; Sp. Grav. 11.33; Sp. Ht. .0315; Coef. Exp. .0000292; Therm. Cond. (Silver=100) 8.5; Elec. Cond. at 0° C. (Mercury=1) 4.8.

An anciently-known metal. Is referred to in the Bible and was worked by the Egyptians. The alchemists connected it with the planet Saturn, and represented it by a scythe, the symbol for Saturn. The ancient Romans much used it for making water-pipes, etc., but they seem to have confused it with tin.

**Occurrence:** the chief ore of lead is Galena,  $PbS$ , which is the commercial ore, but Cerussite,  $PbCO_3$  is not uncom-

mon. Lead is a bluish-grey metal with a bright metallic lustre when freshly cut, but this lustre soon disappears owing to the metal becoming covered with a film of oxide and carbonate. It also acquires this film when placed under water. The metal is soft enough to be indented by the finger nail. It leaves a grey streak when drawn across paper. Traces of antimony, arsenic, copper and zinc harden lead. Lead is not sufficiently malleable to be hammered into foil, but it can be rolled into that condition. It is not very ductile. Under a pressure of 32 tons per sq. in. the metal melts at ordinary temperatures. The metal alloys readily with tin, zinc, antimony, etc., forming very useful alloys. It is chemically reactive, but is fairly resistance to hydrochloric and sulphuric acid. All the chemical compounds of lead are poisonous. Metallic lead is slightly soluble in water containing traces of carbonic acid gas.

**Lead Amalgam.**—Prepared by rubbing lead filings with mercury in a mortar or by pouring molten lead into mercury. Has no definite composition. Possesses a brilliant white colour and remains liquid with as much as 33% of lead. A 50:50 lead-mercury amalgam can be crystallised and a piece of clean lead plunged into this will be found to be covered with crystals of this amalgam when withdrawn.

**Lead Bronze.**—Approximate composition: lead, 10%; tin, 10%; copper, 80%. Introduced about 1870 and used for railway work.

**Leaf Gold.**—Or gold leaf. A very thin sheet of gold obtained by hammering out the mass metal. It is much used for artistic and decorative work on account of its great permanence. "Gold-beating," as the manufacture of gold leaf is called, is one of the oldest of the arts and has so far defied all attempts at mechanisation. Gold leaf as thin as .000004 of an inch has been obtained. Very thin "leaves" of gold transmit green light.

**Lewis's Metal.**—A fusible alloy. M.P. 138° C. Sp. Grav. 8.345. Composition: tin, 1; bismuth, 1 part. The alloy expands considerably on solidifying. It is brittle and can be pulverised to a fine powder.

**Light and Heavy Metals.**—It has often proved difficult to decide where to draw the boundary line between light and heavy metals. This dividing line has at times been arbitrarily fixed by some writers at specific gravities between 3 and 5. The modern tendency, however, is to fix this boundary line between light and heavy metals at the specific gravity of 3.8. Thus metals having a specific gravity of more than 3.8 would be considered to be "heavy." The matter, however, has not yet been definitely decided upon.

**Lipowitz's Metal.**—Composition: cadmium, 3; tin, 4; bismuth, 1.5; lead, 8 parts. Softens at 112° C. and melts completely at 122° C. Has a silvery-white appearance and is useful for soldering Britannia metal, tin and lead, and, also, for taking casts of small and delicate objects.

(To be continued).

# THE "MECHANISM" OF

## High-Speed Pictures at the Rate of



Fig. 1.—The photographic equipment with subject and operator in position

**S**PEECH, to the telephone engineer, is a commodity that must be picked up in one place and delivered promptly, cheaply, and in good condition in another. His first concern is with the means of transport, or transmission, but since this is affected by the peculiarities of the human voice, he must interest himself as well in the characteristics of speech itself. For a number of years members of the Bell Laboratories have been investigating the properties of speech: the frequency of occurrence, for instance, of various sounds; pitch and intensity changes; frequency distribution of energy; and the importance of these and other characteristics to intelligibility. More recently the study has been extended to include the mechanism of speech production, especially the action of the vocal cords in the generation of voiced sounds.

### A Special Mirror

By means of a mirror held at the back of the throat and suitable lighting arrangements, it is easy to view the vocal cords in action; but as the motion of the cords is exceedingly rapid, little can be learned by simply viewing them. To obtain more detailed information, use has been made of high-speed motion picture photography, which has enabled photographs of the rapidly vibrating cords to be taken at rates up to 4,000 pictures per second. When such

pictures are projected at normal viewing rates, about sixteen frames per second, the motion is slowed down by a factor of 250 to 1. Thus, if the cords are making 250 vibrations per second, they appear to make one vibration per second, so that the details of the motion can be clearly seen. This

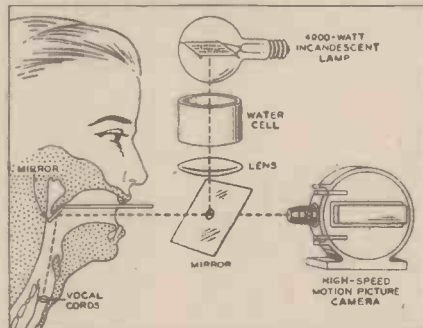

Fig. 2.—Arrangement of equipment for making motion pictures of vocal cords

compares with a ratio of only 5 to 1 that is used in taking ordinary news-reel slow-motion pictures of sporting events; etc.

To provide illumination for the pictures, light from a powerful incandescent lamp is concentrated on the vocal cords by a small laryngeal mirror held in the throat. The

same mirror reflects light back from the vibrating cords to the camera. A diagram of the apparatus is shown in Fig. 2, and a photograph of the equipment, with subject and operator in position, is shown in Fig. 1. The camera itself is a development of the laboratories; its film moves continuously rather than intermittently, a small cube of optical glass rotating at high speed between the lens and the film serving to move the image of the object at the same rate as the film, thus rendering the film and the image stationary with respect to each other. Effective exposure time for each picture is of the order of 1/10,000 second. The film may be projected with a conventional 16-millimeter projector.

### Inside the Throat

Typical "stills" from films taken in the laboratories are shown in Figs. 5, 6, 7 and 8. So that these pictures may be more easily understood, a conventional anatomical drawing of the complete mouth and throat region is shown in Fig. 3. The cartilaginous structure known as the larynx, within which are the vocal cords, is indicated by the arrow. A part of the larynx is the prominence at the front of the throat known as the "Adam's apple"—the thyroid cartilage, shaped like two sides of a triangular box with the apex at the front. A palm-leaf-like structure called the epiglottis attaches to the upper part of the thyroid cartilage. The epiglottis is very flexible and may be either upright, behind the base of the tongue, or folded down to cover the top of the larynx. The rear wall of the larynx is formed by the cricoid and the two arytenoid cartilages. The vocal cords have a common point of attachment to the thyroid cartilage at the front and each is attached to a process of one arytenoid at the rear (Fig. 4). The larynx forms the upper boundary of the trachea or windpipe and opens into the throat of pharynx.

### Respiration

In normal respiration the vocal cords or folds are widely separated at one end, forming a triangular opening of considerable area through which air passes easily. In the production of a voiced sound the cords are drawn close together, but not entirely closed. When the lungs are compressed, as in exhaling, a current of air is caused to flow past the almost closed cords and they are set in vibration.

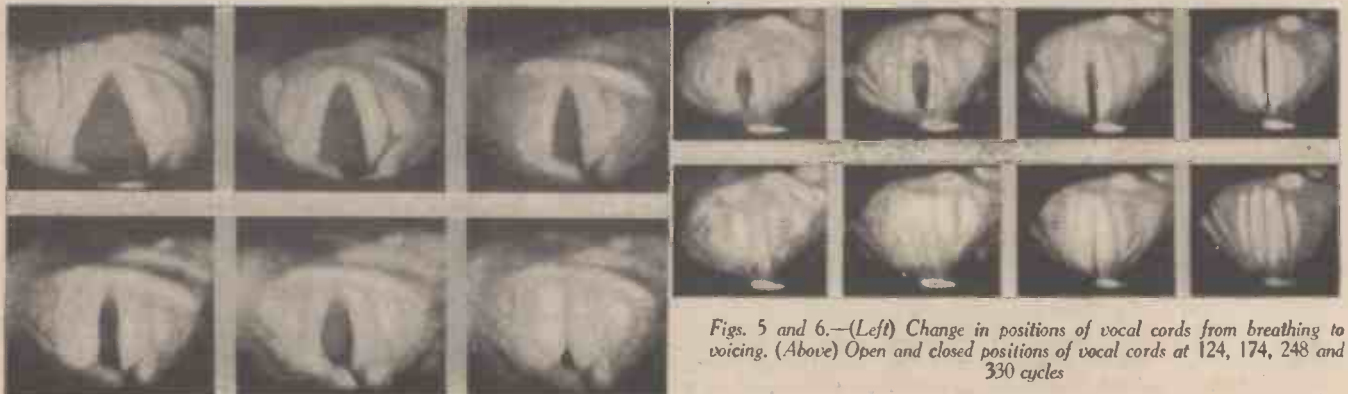

Figs. 5 and 6.—(Left) Change in positions of vocal cords from breathing to voicing. (Above) Open and closed positions of vocal cords at 124, 174, 248 and 330 cycles

# SPEECH PRODUCTION

## of the Human Vocal Cords taken 4,000 Pictures a Second

The breathing position is illustrated in Fig. 5, which also shows the cords being drawn together to begin a sound. Once set into vibration, the vocal cords modulate the direct current of air and generate an alternating air current or sound wave. The sound wave consists of a fundamental and numerous harmonically related overtones. Pitch is determined by the frequency of the fundamental, while the voice is given its characteristic quality by the overtones, which are reinforced in varying ways by the oral cavities. It is this ability of the cavities to reinforce various overtones at will that enables one to produce various speech sounds.

### Voicing

For the pictures the pitch and intensity of the voicing have been varied, but because of the necessity of maintaining the wide-open mouth position, the vowel sound has not been changed. This is the sound "ae," one which gives a particularly favourable view of the larynx. The pitch range covered is from about 120 to 350 cycles per second, and intensities of sound vary from soft to loud conversational speech.

The motion of the cords appears to be rather complex at low pitch, becoming less so as the tone is raised, till at extremely high pitches only the edges of the cords nearest the glottis (as the slit between the cords is called) are seen to vibrate, resulting in a slight change in width of the opening. Vibration also tends to be confined more and more toward the forward portion of the vocal cords. This confined motion is known as the falsetto mechanism. Fig. 6 illustrates the changes in going from a low to a high pitch.

### Cords Relaxed

At a very low pitch the cords appear to be completely relaxed, as may be seen in Fig. 7, which shows one cycle of the cord motion at about 120 cycles per second. Without taking up completely the anatomical explanation, it suffices to say that the tension is small, both in the thyro-arytenoid muscle underlying the vocal cords throughout their length and in the muscles which act on the cords by moving the cartilages to which they attach. As the tension in the various muscles increases, two things take place: the cords become firmer due to contraction of the underlying thyro-

arytenoid, and they are stretched to a greater length by the action of the other muscles. At the low pitch, assuming that they are at the closed portion of the cycle, the cords begin to open from underneath (toward the lungs), the opening progressing upward and outward. The lower portion is also first to close. In other words, there exists a phase difference in the motion between different vertical positions. Horizontally the opening along the length of the cords may also have a phase displacement. When the cords close, a wave-like motion or ripple is seen to pass over the top surface from the glottis toward the walls of the larynx, as the edges of the cords press firmly together.

When the voice is in this range the cords may be tightly closed for as long as half of the cycle. The length of the cords when

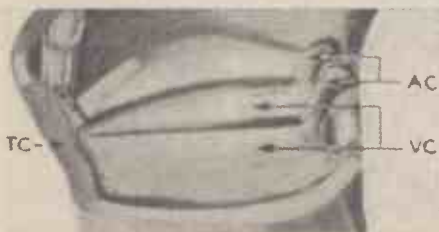

Fig. 4.—VC, vocal cords; TC, thyroid cartilage. AC, arytenoid cartilages

vibrating at about 120 cycles is from  $\frac{1}{2}$  in. to  $\frac{3}{8}$  in. (for the subjects studied). The widest opening is nearly  $\frac{1}{8}$  in.

### Raising the Pitch

As the pitch is raised the motion becomes somewhat simpler; when the folds become more nearly as a unit, so that the opening from below upward is less and less apparent. The length of time they remain tightly closed becomes smaller, until in the falsetto complete closure is usually not attained at all. The length of the cords increases to about  $\frac{3}{4}$  in. and the width of opening decreases to about  $\frac{1}{2}$  in. at 240 cycles. All of these dimensions, of course, vary from subject to subject and change with the intensity of the sound.

The chief variation evident as intensity is changed, without changing the pitch, is that the cords close together very feebly or

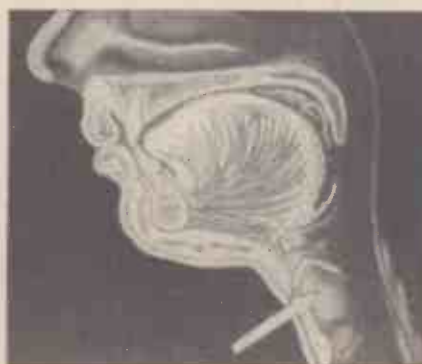

Fig. 3.—The larynx is indicated by the arrow

not at all at very low intensities, while at high intensities they close firmly and may remain closed for an appreciable time, even when vibrating at a high frequency.

One of the most interesting of all the pictures is Fig. 8, showing the production of a cough. Here not only the vocal cords, but the entire larynx, is in movement. At the beginning of the cough the walls of the larynx are greatly constricted, closing completely over the vocal cords. Then air is forced out of the lungs and sudden expansion takes place; the vocal cords are forced apart to a greater extent than ever occurs in normal breathing, and the epiglottis is blown about by the current of air. It is thus apparent how the cough acts to expel any foreign bodies in the larynx.

Reproduced from the Bell Laboratories Record.

## New Aircraft Engine

A NEW aeroplane engine of 24 cylinders, arranged in four banks like a double V, is being mass produced. Stated to be the world's most powerful aero engine, it develops 2,400 horse-power, is supercharged, and built for streamlining into wings and fuselages. The engine weighs less than one pound per horse-power.

## Coloured Bullets

IN the French Air Force, pilots under training are using bullets of different colours, red, yellow, blue and green. This enables the accuracy of their machine-gun fire, at towed targets, to be checked. Fast trainer planes tow the targets, which are canvas "wind socks," as used in R.A.F. training. Fighter pilots swoop towards them and open fire at 200 yards. The targets are examined after the practice, and the pilots' scores are recorded by bullet-marks in their respective colours.

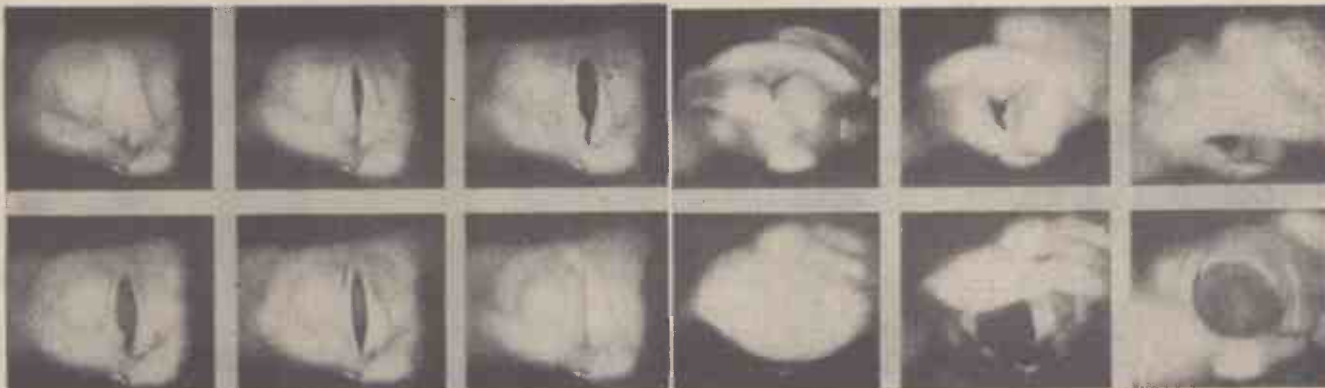

Figs. 7 and 8.—(Left) One cycle of cord movement at low frequency. (Right) Some pictures showing the larynx during a cough

We are indebted to the Postmaster General for the information and illustrations contained in this article



*Sending a telegraphic message by means of the teleprinter and the telephone*

# The Teleprinter

One of the marvels of Modern Communication which one is able to Telegraph messages by any other Telephone Subscriber who is equip-

when it is desired to eliminate noise. It is possible to transmit at a speed of 396 characters or 66 words a minute. Both transmitted and received messages are printed on a roll of paper 8½ inches wide.

The teleprinter being described uses the 5-unit International No. 2 code in which the current impulses forming the code combination for each character are all of equal length. Every 5-unit signal combination is preceded by an impulse which starts the printing mechanism at the receiving end. The operation of the "J" key following the de-

pression of the figure shift key operates an alarm bell at the receiving end. The bell is used for attracting the attention of the distant operator. A high-grade polarised electro-magnet is used for the reception of signals. It has two windings connected in series, each having a resistance of 100 ohms.

## Automatic Starting Switch

Teleprinters may be left unattended for long periods and yet always be ready to receive incoming messages. At the right-hand end of the motor shaft a device for starting and stopping the motor is fitted. At the end of the last signal of a message the machine stops if no further signal is received during an interval of 90 seconds. The first impulse received on the line causes the motor to start again. If required for transmitting, the motor can be re-started by the operator pushing a button inset in

**T**ELEPRINTERS play an active part in the speed and efficiency of modern business. They are used extensively by the post office and for the transmission of news as well as in many other businesses where speed and accuracy are essential. Messages sent by this means are recorded in printed form on the receiving instrument and in addition a local printed copy is recorded on the transmitting machine. The modern instrument, which is illustrated in Figs. 1, 2 and 3 is about twice the size of an ordinary typewriter.

## Unit Construction

Maintenance of the machine is simplified by means of unit construction. When a fault develops it is only necessary to replace the unit in which the fault occurs. In the teleprinter about to be described there are fourteen units as follows:—

- The paper carriage.
- The combination head.
- The type head.
- The ink ribbon unit.
- The main shaft.
- The transmitting unit.
- The cam unit.
- The motor unit.
- The automatic starting switch.
- The keyboard unit.
- The "answer back" unit.
- The printer main base.
- The keyboard main base.
- The wiring unit.

These units are automatically connected, either mechanically or electrically, or both. Driving shafts are so arranged that only one motor is necessary to operate the machine. One high-speed shaft, having a speed of 3,000 r.p.m., is coupled to the motor at one end and to the automatic starter-trip mechanism at the other. This controls the automatic starting switch.

The other shafts are at right angles to the motor shaft, and the one that drives the printing mechanism has a speed of 642.2 r.p.m. In order to preserve the accurate alignment of the printing, the typehead is provided with an outer bearing and also has

an efficient shock absorber. The receiving cam shaft has a speed of 428.6 r.p.m., the transmitting cam shaft 400 r.p.m., and the "answer back" shaft 23.7 r.p.m.

The provision of ball-bearings permits the use of a small motor, thus making power consumption economical, and frequent lubrication unnecessary.

The paper roll is supported in a paper chariot which is coupled to the paper carriage. The paper chariot moves from side to side with the carriage, and thus ensures the correct alignment of the paper. A spring, which is wound up during printing, returns the carriage to the beginning of the line following the receipt of the carriage return signal. As on a typewriter, a bell rings when the end of the line approaches. A ribbon inking device similar to that used on a typewriter is employed on a teleprinter. A special silencing cover can be fitted

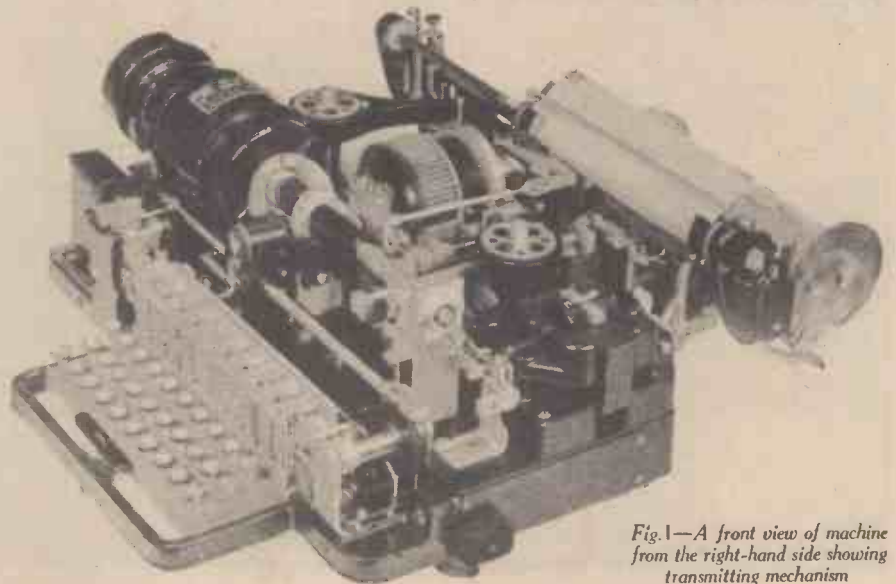

*Fig. 1—A front view of machine from the right-hand side showing transmitting mechanism*

# —How It Works—PART 1

is the Teleprinter with means of a Telephone ped with a Teleprinter.

the teleprinter cover. The motor therefore only operates during the period when the teleprinter is being operated.

## Answering Back

To enable operators to verify that they have established the correct connection, the teleprinter is fitted with what is known as an "Answer Back" device. This device is operated by first depressing the Figure Shift Key and then holding down the key marked "Who are you?" This causes the "Answer Back" device on the "called" operator's machine to repeat its exchange number to the "calling" operator.

## Sending Messages

On depressing a key a clutch is engaged. A series of cams are coupled to the clutch and control the sequence in which the impulses forming the character combination are transmitted. The depressed key is immediately locked down and all other keys on the keyboard are prevented from moving until the code combination has been signalled. Certain of the comb bars, which are free to move longitudinally, are allowed



Fig. 2.—A front view of the teleprinter from the left hand side showing the transmitting mechanism.

to be displaced in accordance with the signalling code for the character which it is required to transmit. A displaced comb bar corresponds to a "marking" signal and a bar which has not been displaced to a

"spacing" signal. The position of each of the comb bars determines whether the "marking" or "spacing" signal shall be transmitted, and the sequence in which the signals are sent is controlled by the selecting levers as they are affected by the rotation of the transmitting cam.

In addition to the current impulses forming the particular character combination, two impulses are automatically transmitted every time a key is depressed. The "start" impulse is one of these. It precedes the character combination and operates the electro-magnet controlling the printer at the receiving end. This, in turn, operates the receiving clutch mechanism. The electro-magnet armature is moved to the "marking" contact by the other impulse. The receiving camshaft is disengaged from the ratchet and the receiving mechanism is brought to rest ready for the reception of the next signal impulse. These are known as the "start" and "stop" impulses.

## Receiving Messages

On the receiving teleprinter the incoming signals pass through the coils of the electro-magnet. A shaft attached to the magnet armature is free to move in either of two directions under the control of the armature. Five comb-setting fingers are withdrawn, or advanced, from their normal position of rest in the same combination as that predetermined on the combination bars on the transmitting end of the circuit. A lever carrying a striker effects this. Its movements are synchronised with the operation of the transmitter tongue as reproduced by the movements of the electro-magnet armature.

The striker oscillates in front of the ends of the five comb fingers. Depending upon the movements of the electro-magnet armature in a "marking" or "spacing" direction, certain of the fingers are pushed inwards where they engage the printing mechanism. The movements of the magnet armature are dependent on the incoming signal impulses, therefore the character combination set up on the transmitter at the sending end is accurately reproduced on the printing mechanism at the receiving end.

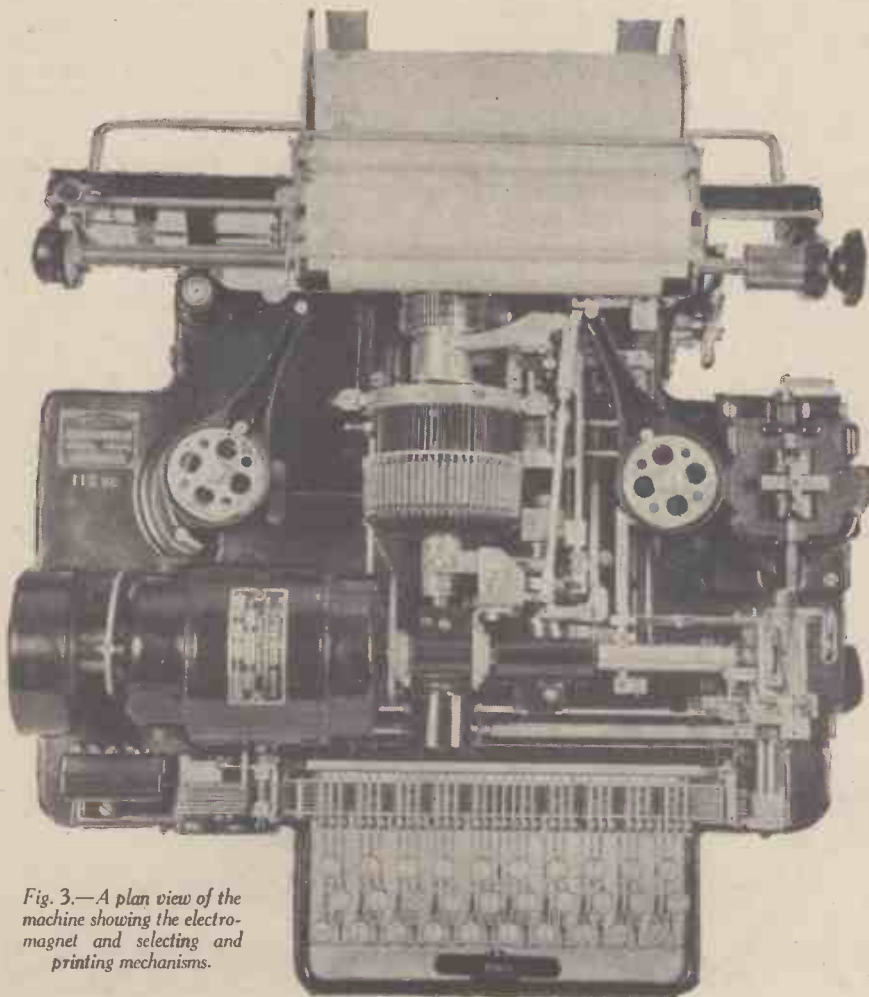

Fig. 3.—A plan view of the machine showing the electro-magnet and selecting and printing mechanisms.

### Printing Mechanism and Character Combinations

In the construction of the combination head the principles of the combination lock are employed. A series of bellcranks or latches are mounted radially on annular bearings round the end of a stationary drum, through which passes the revolving type-head spindle. In accordance with the position of the comb-setting fingers, one of the latches is drawn into an aligned slot prepared across the edges of the receiving combs. In this position, the end of the latch is introduced in the path of the revolving typehead and arrests its motion. The selected type is thus interposed between the type hammer and the paper. Each character is printed at the moment when the selection of the succeeding character is set up on the comb-setting fingers. In consequence, to ensure the printing of the last character of the message, a letter space signal must be sent to print that character.

There are thirty-two different character combinations available by the use of the 5-unit signalling code. For transmitting figures and special characters, known as "secondaries," a much larger number of combinations is required. Some of the keys are, therefore, arranged for sending one of two characters as needed. Two special combinations make this possible, one

The position of the Send-Receive switch is above the transmitting contacts. On the right of Fig. 5 the Start-Stop Selecting Lever and the Selecting Levers can be seen. The upper ends of the selecting levers and the upper end of the transmitting cam pawl abutment can be seen in Fig. 6. The trip lever and trip bellcrank are shown on the right.

The keybars are free to move vertically behind a pair of guide plates shown in Fig. 4. These plates run the whole length of the keyboard assembly, and are situated at the upper and lower ends of the vertical portion of the keybars. Each key is fitted with a pair of rollers in order to reduce friction. The horizontal portions at the top of the keybars are seen resting above the comb bars. The ends can be seen at the extreme left of the keybars. The keys also pass through slots in four racks which prevent lateral movement. These racks are shown at the extreme front of the keys and at the top behind the guide plate. A restoring spring is fitted to each key so as to return it to its normal position when it is released after transmission of a signal combination. One of the keybar racks also acts as a guide plate.

### Locking Bars

There are two locking bars: one is controlled by the Resetting Cam and the other

prevent the depression of a second key until after the first has been released. This bar is situated immediately behind the bevelled rear extensions of the keybars. When a keybar is depressed, an abutment on the vertical portion of the keybar moves the trip bar downwards. This causes the locking bar to be drawn forward under the tension of the locking bar spring to a position immediately beneath the bevelled portion of those keybars which have not been depressed. A spring tends to turn the locking bar arm forward on its pivot thereby bringing this second locking bar under the end of the keybars. This action is prevented by the trip bar arm while all keys are normal but immediately the key depresses the trip bar, the second locking bar is drawn under the end of the keybars which have not been depressed.

### Comb Bars

Each of the comb bars has a series of projections on its upper edge arranged in accordance with the signalling code. These projections determine the combination of signal units to be transmitted for any given character. The projections are situated on the bars so that, with the bars on their normal position the projections are adjacent to the left-hand side of the horizontal portion of the keybars with which it is required they shall engage when operated. Therefore, any key, other than a key which causes five spacing units to be transmitted, must engage with a projection on one or more of the comb bars.

The purpose of the Resetting Lever is to hold the comb bars and the first locking bar to the left, against the tension of the comb bar controlling springs, to release them when the resetting cam is rotated, that is, when a keybar is depressed, and to restore the comb bars and locking bars to their normal position on the completion of one complete revolution of the resetting cam.

### Transmitting Cam Clutch

The Transmitting Cam is constructed as a sleeve and is driven through the transmitting clutch mechanism. A shaft passes through its centre. This shaft carries a ratchet wheel. Actually there are two ratchet wheels, staggered half a tooth, and two pawls mounted on the same pivot. Each of the pawls is pivoted to the cam, and a spring tends to force the hooked ends of the pawls into engagement with the ratchet. This is normally prevented by the action of the transmitting cam pawl abutment.

When a key is depressed, the projection on the vertical portion of the keybar causes the trip bar to move downwards. The trip bar is coupled to a bellcrank, which in turn is coupled to the trip lever. This lever turns in a clockwise direction, and the trip finger is drawn to the right. The transmitting cam pawl abutment is now lifted from the ratchet pawl, which is allowed to engage with the ratchet.



Fig. 4.—Keyboard and transmitting units, detached from main base.

for operating the "Letter Shift" mechanism and the other for operating the "Figure Shift" mechanism. The type selecting mechanism is designed so that all combinations, received between the receipt of a "Letter Shift" signal and the receipt of a "Figure Shift" signal, cause letters to be printed, and the reverse when the "Figure Shift" key is depressed.

A general outline of the teleprinter and its operation having been given, a closer look at some of the units will prove interesting.

### The Transmitting Mechanism

The transmitting mechanism, which is shown in Figs. 1 and 2, is divided into two units, a keyboard unit and a transmitting unit. The keyboard unit and the transmitting units, detached from the main base, are shown in Fig. 4 and in Fig. 5 the transmitting unit is shown with the cover removed. Another view of this unit is shown in Fig. 6.

by the depressed keybar. One of these is situated parallel to and at the rear of the comb bar assembly, viewed from the front of the keyboard. Its function is to lock a depressed keybar until the required combination of current impulses has been transmitted. When the Resetting Cam commences to rotate, the bottom edge of the Resetting Lever moves to the right and the comb bars, which are required to be moved for the signal to be transmitted, are pulled to the right under the tension of their respective controlling springs. One of the small hooked projections on this locking bar engages in a small hole near the end of the depressed keybar and locks it in the operated position until the locking bar is, reset to normal by the resetting lever. This happens when the resetting cam has made a complete revolution. The upward pressure of the restoring spring resets the depressed keybar.

The second locking bar is provided to

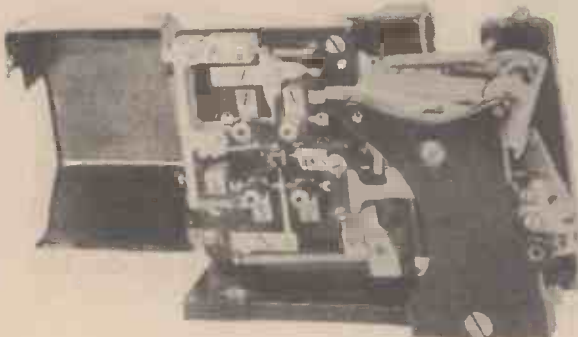

Figs. 5 and 6  
— Two views of the transmitting unit

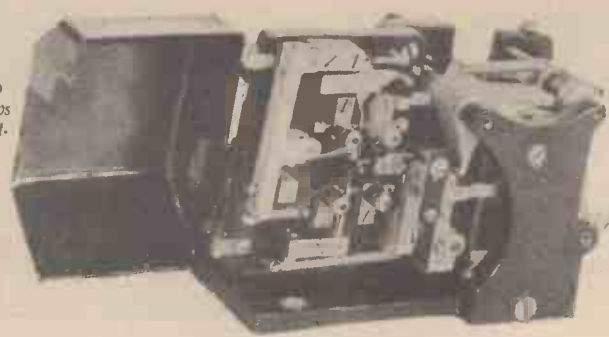



# This is FIGHTING TALK

Two vitally important matters demand your attention—one is your immediate future, the other your position when peace returns.

Perhaps you have lost your job and have to turn to some different kind of work. Perhaps you are faced with new duties and requirements calling for specialised knowledge. Or perhaps you are realising at last that without trained efficiency a man is badly placed in the life of to-day.

## I.C.S. FACTS

Branches in 30 countries ; students in 50. Total of British students 900,000.

The Admiralty and other State Depts. have made special arrangements with the I.C.S. for training of men.

More than 1,000 Instruction Manuals, prepared by I.C.S. in London for postal teaching, are marvels of clearness, accuracy and practical helpfulness.

80 Instructors, many of them Associates, Members or Fellows of their respective technical bodies. All are specialists.

400 Courses of Instruction, including one for **YOU**

**LIFE HAS BECOME A BATTLE. WE MUST FIGHT IF WE ARE TO HOLD OUR OWN**  
**Technical Training is a National Necessity.**  
**The Government are making widespread demands for men possessing it.**

The I.C.S. have been giving a technical training through the post, in unsurpassed quality, for nearly half a century. We trained many thousands of men during the years 1914-18 and are splendidly equipped to render similar service throughout the coming months or years of this second Great War.

*If you need technical training, our advice on any matter concerning your work and your career is yours for the asking—free and without obligation. Let us send you a booklet dealing with the subject in which you are specially interested. It is packed with valuable information. DON'T DELAY. Make "ACTION" your watchword.*



**The time to start preparing yourself for the fight is NOW**

### COUPON FOR FREE BOOKLET

USE PENNY STAMP ON UNSEALED ENVELOPE

**INTERNATIONAL CORRESPONDENCE SCHOOLS, LTD. (Dept. 95), International Buildings, Kingsway, London, W.C.2**

Please send me your booklet containing full particulars of the Course of Correspondence Training before which I have marked X. I assume no obligation.

- |   |  |  |   |
|---|--|--|---|
| <input type="checkbox"/> Accountancy              | <input type="checkbox"/> Diesel Engineering        | <input type="checkbox"/> Lettering                       | <input type="checkbox"/> Scientific Management        |
| <input type="checkbox"/> Advertising              | <input type="checkbox"/> Draughtsmanship           | <input type="checkbox"/> Mechanical Drawing              | <input type="checkbox"/> Short-Story Writing          |
| <input type="checkbox"/> Aeronautical Engineering | <input type="checkbox"/> Electrical Engineering    | <input type="checkbox"/> Mechanical Engineering          | <input type="checkbox"/> Steam Engineering            |
| <input type="checkbox"/> Air Conditioning         | <input type="checkbox"/> Engineering Shop Practice | <input type="checkbox"/> Mining Engineering              | <input type="checkbox"/> Surveying                    |
| <input type="checkbox"/> Architecture             | <input type="checkbox"/> Fire Engineering          | <input type="checkbox"/> Motor Engineering               | <input type="checkbox"/> Telephone and Telegraph Eng. |
| <input type="checkbox"/> Boiler Engineering       | <input type="checkbox"/> Garage Management         | <input type="checkbox"/> Pattern-making                  | <input type="checkbox"/> Textiles                     |
| <input type="checkbox"/> Book-keeping             | <input type="checkbox"/> Gas-Power Engineering     | <input type="checkbox"/> Plumbing                        | <input type="checkbox"/> Welding, Gas and Electric    |
| <input type="checkbox"/> Building                 | <input type="checkbox"/> Heating and Ventilation   | <input type="checkbox"/> Radio Engineering and Servicing | <input type="checkbox"/> Wireless Engineering         |
| <input type="checkbox"/> Chemical Engineering     | <input type="checkbox"/> Hydro Electric            | <input type="checkbox"/> Salesmanship                    | <input type="checkbox"/> Woodworking                  |
| <input type="checkbox"/> Civil Engineering        | <input type="checkbox"/> Journalism                | <input type="checkbox"/> Sanitary Engineering            | <input type="checkbox"/> Works Management             |

#### EXAMINATIONS

Technical, Professional, Matriculation and Civil Service. State the one you wish to pass.....

NOTE.—If your subject is not on the above list, write it here.....

NAME..... Age.....

ADDRESS .....



## TRUE-TO-SCALE MODELS

### BRITAIN'S NAVY "SHIPSERIES"

Waterline Models  
Scale 100'...1"

Portraying every type Now  
making HISTORY.

From Destroyers 6½d. each to  
Battleships 3s. each. 32 different  
types, plus Accessories,  
Rocks, Cliffs and Coastline  
Sections to build FIORDS.

OUR LATEST MODEL

### NORWEGIAN FIORD

complete with units of

### THE BRITISH NAVY

Price 10s. 6d.



Send stamps 2½d. for complete LISTS : A. J. HOLLADAY & Co., Ltd. (Desk P.M.) 3, Aldermanbury Ave., London, E.C.2.

## SKYBIRDS

1/72nd Solid Scale Model  
Aircraft Construction and  
Aeronautical Accessories.

AIRCRAFT IN THE NEWS:—

SPITFIRE	} Complete Sets 3/- Each	
HURRICANE		
MORANE		
CURTISS		
MESSERSCHMITT	} 5/6 each	
SKUA		
BLENHEIM		8/- "
DORNIER		8/6 "
HAMPDEN	10/6 "	

Each set complete with descriptive leaflets and Scale drawings.



## MODELS for the ENGINEER

Last Autumn a new catalogue "Steam Locomotives, Stationary Engines and Everything for the Model Constructor" (AB.12) was introduced, and has been so popular among model men that it ran out of print this spring. We are now pleased to announce the publication of the REVISED EDITION, which is available from our Head Office, Northampton, price 8d. post free.

Other catalogues are:—

- GR.12. Gauge "O" railways and equipment, 3d.
- TT.12. Gauge "OO" railways and equipment, 2d.
- Also Laying Permanent Way, 2d. Building a Traction Engine, 3d. Building a gauge "O" steam Mogul, 6d.



## BASSETT-LOWKE LTD., NORTHAMPTON

LONDON: 112, HIGH HOLBORN, W.C.1. Official air-raid shelter on the premises. MANCHESTER: 28, CORPORATION STREET

### Solders without heat



PENN'S  
PLASTIC  
SOLDER

Mends and Joins all Metal Articles, Enamelware, etc. Aluminium, Iron, Zinc, Tin, Brass and Copper. Repairs Kettles, Pots, Pans, Boilers, Pipes, Petrol Tanks, Car Radiators, etc., without heat. Merely press into hole, it hardens like iron. Won't chip, burn, boil or bake out. Joins any metals and replaces solder for ALL its uses in Home, Garage, Workshop, etc.

9d.

Post 3d.  
3 Tubes 2/- Post  
Free. Send P.O. or  
English stamps.

Wm. PENN LTD., Dept. (P.M.S.)  
623, Holloway Road, London, N.19

## ADD INCHES TO YOUR HEIGHT

Increases in height up to 4½ inches have been obtained with a wonderful new appliance known as the "ROTA" Height and Spinal appliance. The "ROTA" loosens up the spine and gives room for the growth of the pads of cartilage separating the spinal bones. This cartilage is the quickest growing substance in the body, and given a chance to grow, grow it will.

The "ROTA" is fully described in a 16-page book, sent free on application to Chas. T. Trevor (Dept. P.M. 183), 17 Penford Street, Camberwell, London, S.E.5.



The 'ADEPT' LATHE  
1½ in. centres, 6 in. between centres.  
With compound slide-rest, 24/-, or with hand-rest only, 15/- Screw Tail Stock, 6/- extra. Post 1/-.

(Stamp Please)  
'ADEPT' 2½ in. INDEPENDENT 4-JAW CHUCK, Price, 16/-; Post 6d. THE SUPER 'ADEPT', 35/6.

F. W. PORTASS Sellers Street, SHEFFIELD

## BLUSHING

FREE to all sufferers, particulars of a proved home treatment that quickly removes all embarrassment, and permanently cures blushing and flushing of the face and neck. Enclose stamp to pay postage to Mr. M. Temple (Specialist), 32 "Commerce House," 72 Oxford Street, W.1. (Est. 39 years.)

PROTRUDING EARS

ORO, a simple remedy, sets them in position immediately. INVISIBLE, comfortable, and harmless, used any time by adults and children. Endorsed by physicians and users as the best method for correcting this disfigurement. Write for free booklet and testimonials to:—M. TRILETY (R203), 45 Hatton Garden London, E.C.1.

Easily made from our castings  
From 12/6 Per Set.

J. HALLAM & SON  
Upton, Poole, Dorset.

MINIATURE PETROL ENGINES . . . for  
Aeroplanes and Speed Boats. 1 to 60 e.e.  
Send 3d. for particulars.

## FOYLES

BOOKSELLERS TO THE WORLD

New and secondhand books on all technical subjects  
113-125 CHARING CROSS RD., LONDON, W.C.1  
Telephone: Gerrard 5660 (16 lines)



# Building a 2½-in. Gauge Model of the "Flying Scotsman"—5

As already described the locomotive is provided with a spirit-fired water-tube boiler, the tender containing a water tank and spirit reservoir. For those readers who prefer a coal-fired boiler for this model, a suitable design is given in the accompanying illustrations. The length and overall diameter is, of course, the same as the spirit-fired boiler, but the internal construction is different. Instead of external water tubes, there are internal "fire," or flue tubes, and firebox, as shown in the longitudinal section of the boiler given in Fig. 35.

## Boiler Construction

The boiler barrel proper consists of a piece of 3 in. outside diameter solid drawn copper tubing, 12½ in. long, the rear end being cut away, as shown, to allow for the angularity of the firebox front plate. The rear firebox plate is also inclined, and both are deeply flanged for riveting to the inner firebox top and sides. The outer firebox, throatplate, and back plate are also flanged, as indicated.

The whole boiler may be either tack-riveted and silver-soldered, or fully riveted

## Constructional Details of the Coal-fired Boiler

and soft soldered. By tack riveting is meant the holding of the plates together with a few rivets at long pitch. As shown in the illustrations, it is intended that the outer firebox, with the boiler barrel, shall be completely assembled, riveted, and soldered or brazed, including the back plate. The inner firebox is assembled, and riveted and brazed in the same way.

### Tube Plates

In the firebox tube-plate, the seven holes for the tubes have to be carefully marked out and drilled for the ¼ in. diam. flue tubes, which are of solid drawn copper. The holes should be drilled slightly under-size, and reamed out a good fit for the tubes. The flanged tube plate, at the front end of the boiler, also has the holes for the

flue tubes bored and reamed out. In this tube plate holes for the longitudinal stays, steam-pipe fitting, and blower tube, have also to be drilled. The position of these holes is indicated in Figs. 36, 37 and 38.

The foundation ring between the inner and outer firebox walls, consists of a strip of 14 gauge brass or copper, and this is first secured to the inner firebox, as is also the ring around the firehole opening (see Fig. 35). The inner firebox is placed in position in the outer firebox and riveted. The positions of the stays are then marked out (Figs. 35 and 38), and over each point where a stay is to pass a small circular plate is soldered. These plates, which are of hard brass, are the same thickness as the firebox walls, and are ⅞ in. diameter. They are soldered to the inside and outside of the firebox. The stays are of hard-drawn brass or bronze rod, screwed No. 3 B.A., and the firebox walls and circular plates are drilled and tapped accordingly. The threaded ends of the stays are cut off about ⅓ in. beyond the surfaces of the circular plates, and are riveted over. The top ends of the crown stays, also screwed 3 B.A., pass through sheet-brass straps arched over

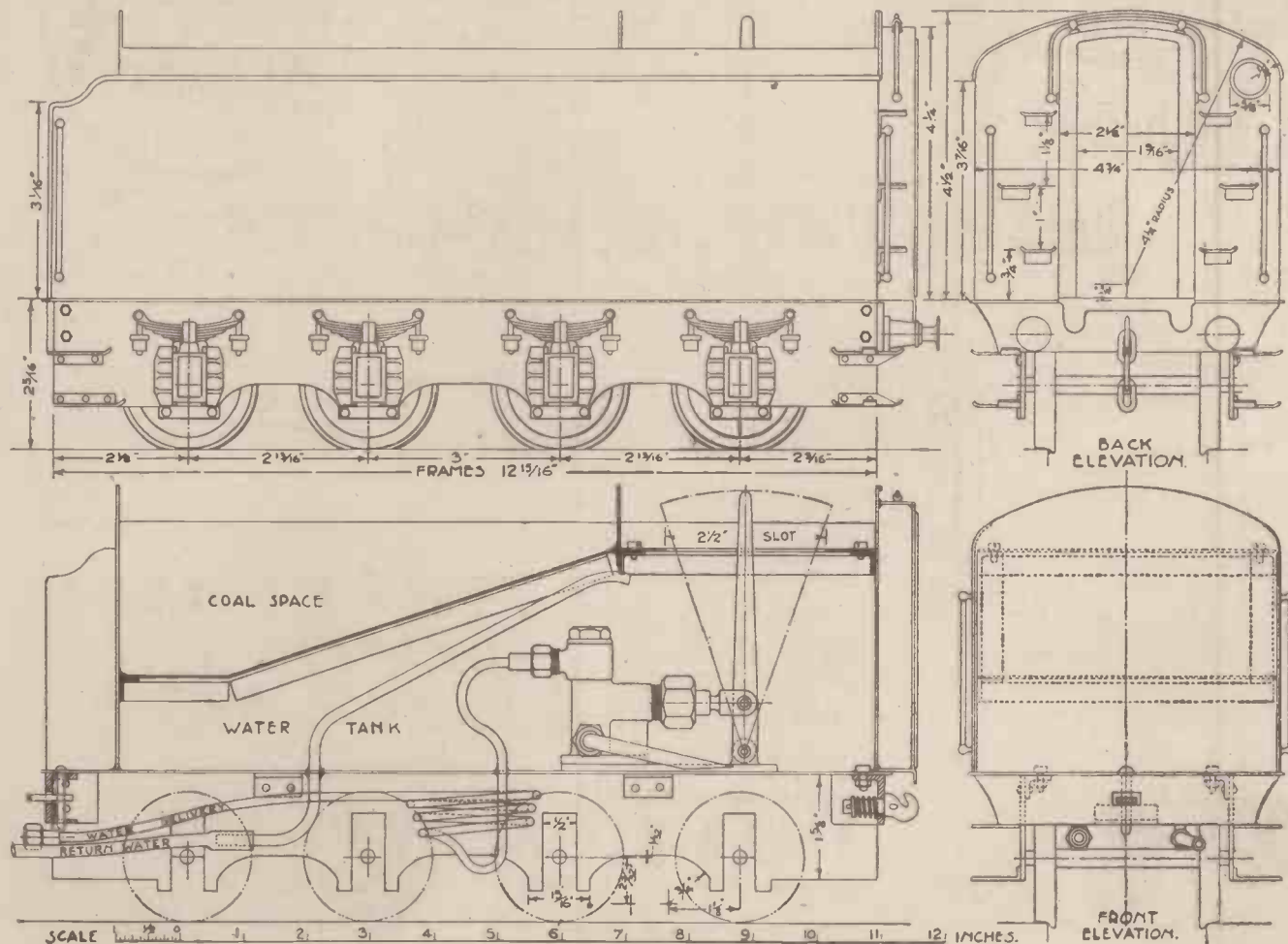

Fig. 40.—Side view, section, and end views of the tender for the coal-fired model "Flying Scotsman."

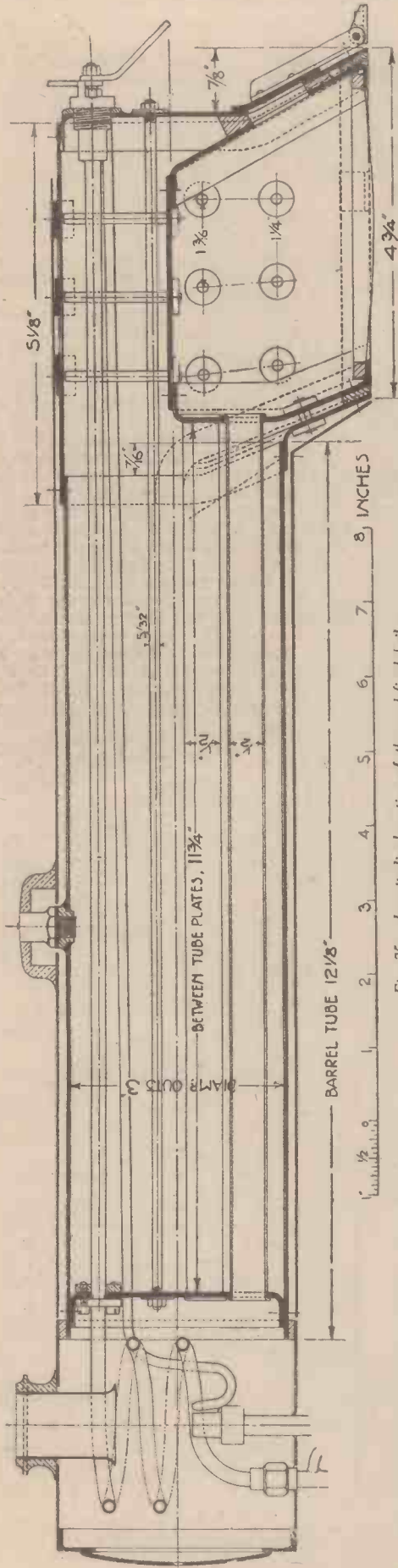
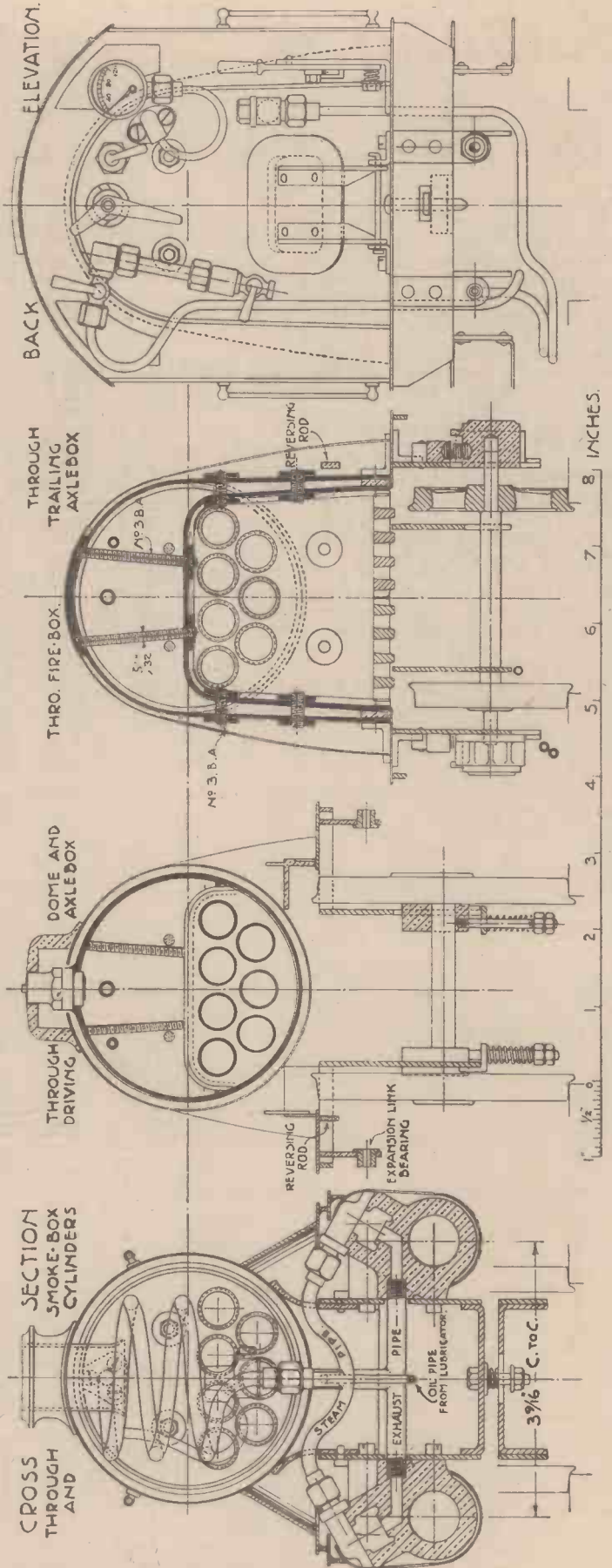

Fig. 35. Longitudinal section of the coal-fired boiler.



Figs. 36 to 39. Cross-sections through cylinders, boiler, and firebox, and rear view of boiler fittings in the cab.

the outer firebox plate, the lower ends of the stays passing through small circular plates soldered inside the inner firebox (Fig. 38). The arched straps are also soldered in place.

#### Fitting the Flue Tubes

The flue tubes are inserted through the tube plates, beaded over, and expanded with a well-greased drift, at both ends, and soldered. The rear ends of the tubes must, of course, be expanded and soldered before the back of the inner firebox is riveted and soldered.

The longitudinal stays, which run the whole length of the boiler, cannot be screwed into the front tube plate and

boiler back plate. These plates therefore have holes drilled a clearance fit for the stays which are secured by No. 3 B.A. nuts, after placing a washer over the end of each stay. The joints must be soldered. The firebars are formed in one piece as a light iron casting, which rests on flanges bent inwards from the front and back plates of the inner firebox.

The firehole door, which is shaped from a piece of brass plate, has two pieces of brass angle riveted to it, the lower ends of the angles being pivoted to two brackets screwed to the footplate (Fig. 39).

It will be seen, by reference to Fig. 39, that the positions of all the boiler fittings inside the cab, with the exception of the

regulator and blower valve, have been altered. This is to allow for the boiler stays and firehole door. Another noticeable alteration is the superheater, which in the coal-fired boiler, is coiled in the smoke-box (see Fig. 35).

#### The Tender

It will be seen on referring to Fig. 40 that the boiler feed pump is placed at the rear of the tender, and above the water tank, at the front, a coal space is provided. Part of the top plate of the water tank is inclined, as shown, and is soldered to brass angles attached to the tender side plates.

All the other parts of the tender are similar to those on the other tender.

## A New One-battery Portable

### Details and Test Report on a G.E.C. Portable Superhet

**T**HERE are many very interesting points about the G.E.C. four-valve battery portable (Model BC4141) which was recently introduced. It is a superhet, and gives real superhet performance, which means that it will give good reception of a number of stations when used in any part of the country. Another important item is the provision of a single dry battery which serves for both high- and low-tension; there is no accumulator to need charging or to add seriously to the weight of the receiver.

The battery (type BB395) supplies H.T. at 90 volts, and L.T. at 1.5 volts. The latter is to feed the filaments of the 1.4-volt battery valves which are used. These valves are used in the following order: X.14 frequency changer, Z.14 intermediate-frequency amplifier, HD.14 second detector, A.V.C. and first L.F. amplifier; and N.14 output. All of these valves are of the comparatively new, dry-battery type with octal base.

#### Sound Design

In constructional details the new G.E.C. portable is extremely interesting. This is because the receiver itself, along with battery platform, is made as a rigid framework and is fitted with a really substantial carrying handle. The outer case, which carries the speaker grille, is made from shaped plywood attractively covered in imitation grained leather. This cover is entirely free from sharp corners and can be removed for replacing the battery (not more often than about once in three months) simply by taking out two screws and lifting it. A valuable feature is that the outer shell does not have to support any weight and can therefore be made very light.

It will be seen from the accompanying illustration that the three controls and tuning scale are on top of the receiver chassis and are accessible due to the rectangular hole in top of the shell. Of the three knobs, that on the right is for on-off switching and for changing from medium to long waves, the centre knob is for tuning and that on the left is for volume control.

#### Built-In Aerials

The receiver itself is a model of compactness, despite the fact that the permanent-magnet speaker unit is 6½ in. in diameter and the L.F. transformer is not a midget. There are two built-in frame aerials, for long- and medium-wave use respectively. In addition, however, there is provision for connecting external aerial and earth

leads when it is wished to increase the range of reception.

It should be mentioned in passing that the dry battery has a valve-holder type connector socket into which a corresponding plug is inserted when the battery is installed. Incorrect connection is therefore impossible, however carelessly the job may be done. As the complete battery is listed at 10s., it will be seen that running costs are very modest for a receiver of this type.

#### Excellent Reception

We have had one of these sets on test for some time, and have been very well pleased with the results obtained. Tuning is childishly easy, and the fact that the station and wavelength marked scale is accurately calibrated is of great assistance.

Our first tests were made in our offices, which are on the fifth floor of a steel-framed building in the Strand, London. In daylight it was possible to receive many stations on the medium waves, and Radio Paris on long waves, at good strength. The Home and Forces stations were received at such strength that it was necessary to turn the volume control well down to avoid overloading the speaker, whilst Radio Paris could be listened to in comfort with the control below maximum. This reception was obtained, it should be noted, in conditions which are very unfavourable, and in which many portable receivers are able to give only mediocre results.

As is always the case when using a frame aerial, there was a useful directional effect but this was not sufficiently critical to make the tuning-in of even weak stations difficult. It was, however, useful in minimising interference from electrical equipment in the building.

Out-of-doors, or in the home (where the shielding effect of steel girders is not experienced) reception was still better. In fact, when using only the frame aerials the range was comparable with that of many older-type battery receivers when connected to a good aerial-earth system. By connecting aerial and earth leads the range was, as expected, considerably extended and was as good as that with the average good "home" receiver with a similar circuit.

#### Dimensions

For the type of receiver, the quality of reproduction was fully satisfactory, on both speech and music. Even the critical listener would find little to complain of in this direction. The makers introduced the set for use in any conditions, and they have succeeded, for it weighs only 19 lb., and



The G.E.C. Portable Superhet

the overall dimensions are 11½ in. by 12½ in. by 7¾ in. In addition, the finish is such that it should withstand the rough usage which it might receive in an air-raid shelter, or when carried by train or car. An important feature in this respect is the flexible mounting of the metal chassis, frame aerials and controls within the interior wooden framework.

The price is £8 18s. 6d. complete.

## For the Schoolroom

**A**NOTHER variety of the scholastic blackboard has made its advent. The object of the invention is to furnish a board with greater facilities in the way of colours and guiding lines than characterises its sable predecessor.

The principle of the device is that of a slate which was in evidence in the Victorian era, when it was used as a child's plaything. The new board has a translucent surface of frosted or ground glass. Behind this is a board providing a light-reflecting background on which there are faint lines. Any coloured chalks may be used to distinguish different parts of a diagram or lesson.

## Manicure by Machinery

**A**N electric manicurist has made its appearance. Working somewhat on the principle of the electric shaver, it combines brush, nail file, emery bar and massager. It is only four and a half inches long, and one and a half inches in diameter. The usefulness of this little machine is not limited to beautifying the hands. A jeweller has used it to clean rings and watches.

## Self-Release Rafts

ACCORDING to Lloyd's List of *Shipping Gazette Supplement*, "Safety at Sea," rafts are recognised as best for emergency. Small ships have hitherto found difficulty in stowing them, but this has now been overcome by a device which suspends the rafts outside the shrouds. They can be released by lifting a ring and if the ship sinks quickly, they will float off. Self-igniting lights which are inextinguishable in water are fitted to buoyant apparatus. These lights must be electrically operated if the ship is a tanker or oil-fuelled. Another safety device is the raft distress light which flashes out the international distress signal automatically for 48 hours.

## Television in Aircraft

INVENTORS in many countries have for some time been experimenting with television apparatus which can be carried in pilotless aircraft. Transmitting machinery has previously been of such size that a 10-ton lorry has been needed to carry it. It is now claimed in America that the size and volume has been so much reduced that the apparatus can be packed into seven

# THE MONTH IN SCIENCE AND

hopes. Outdoor tests are being planned. The engine uses a new type of small battery and yields power equivalent to a petrol engine. The engine is about the size of a silk hat. If tests are successful, Mr. McCurdy intends to offer the project to the Government.

## Armoured Target Boats

IN order to give the R.A.F. real bombing practice, special high-speed target boats have been designed. The boats are manned by a coxswain, deckhand, and wireless operator. Since the practice bombs used are definitely dangerous, the boats are filled with a preparation known as Onazate. It is a composition of expanded rubber ten times lighter than cork. The boats were designed by Mr. Scott-Paine and are forty feet long with a humped back where the

was cut off by canvas screens and he was guided solely by instruments. He kept his machine on the ground until it attained a speed of 110 miles an hour and then climbed to 4,500 feet in a cross wind. He lined up on a course given him by his navigator. The calculations were so accurate that an hour after his departure he was able to give the exact minute when the plane would be over Langley Field.

When he landed he followed a wireless beam from the field, and was warned by the flashing of an electric bulb on the instrument panel when he was 800 feet from the airport. He received a second indication of the wireless marker beam at the edge of the airport. The wheels of the machine bumped on the ground five seconds later.

## New Aerial Mine-Bomb

THE United States Government has been offered a new secret aerial mine-bomb, by its inventor, Lester Barlow, an aerial engineer. It can be produced at one-fifth the cost of T.N.T. The inventor claims that it is a super-high-explosive, is economical to produce, it can be controlled, and does not have to hit the objective to destroy it. It is so powerful, states the inventor, that it can sink warships up to about 10,000 tons, completely destroy life on the decks of a battleship, and wipe out its A.A. guns, or leave a battleship crippled and helpless.

Its shape is a secret, but it consists of a thin metal shell containing liquid oxygen under great pressure, mixed with specially prepared carbon substances. A secret method of detonation produces an enormous gas expansion which destroys human tissues without tearing them with metal. Bombers could carry six at a time and would not need to see the objective. The inventor states that in tests with only five pounds of the explosive, plaster walls have been cracked two miles away.

## New Radio System

MAJOR EDWIN H. ARMSTRONG, a Columbia University professor, who has been responsible for numerous radio inventions as well as being a pioneer of the modern super-heterodyne circuit, has developed a new system of broadcasting which cuts out interference from lightning, sunspots, tramcars, etc. Transatlantic broadcasts will no longer be cancelled if the system is adopted universally. The new system is already being used by 16 American stations, and their broadcasts are free from "atmospherics" and fading.

Eighty other stations are hoping to use the system and have applied for licenses. The Federal Communication Commission is considering the granting of an exclusive ultra-short wavelength to Major Armstrong.

## A New Design of Lifebelt

AN Australian-designed lifebelt has been adopted by the British Admiralty and it is to be issued to the personnel of the Royal Navy.

The new lifebelt, which is fitted round the chest, is inflated by breath, and keeps the head of the wearer above water.



The new automatic lightships or floats which will replace the vessels which have been subjected to Nazi bombing attacks off the East Coast. The floats are automatic and need no crew. They are about 30 ft. long—half the size of an ordinary lightship—have a lantern and bell, and the lights will burn for two months unattended. To planes they would present a very small target

light suit-cases. If the invention lives up to its claims, observation planes equipped with it, and either manned or unmanned, and operated by remote control, can now send views of the underlying terrain back to army headquarters or to receiving stations on ships. This television eye can penetrate through the mist and haze that obscure human vision.

## Electric Aeroplane Engine

EXPERIMENTS are being made with a new type of electric aeroplane engine. According to Mr. J. A. D. McCurdy, president of Aircraft Industries, Ltd., the results are so far promising, but he says that the company are not building up false

heavy armour plating protects the crew from direct hits. On one occasion a bomb hit an unarmoured part and went right through the boat. It was prevented from sinking by the Onazate. A depot ship always stands near by.

## "Blind" Flight of 300 Miles

MAJOR CARL B. McDANIEL, of the United States Army Air Corps, recently accomplished the first completely "blind" flight ever made. He flew a 22½-ton bombing aeroplane without sight of anything outside the cockpit of his machine. The distance of 300 miles was covered in two hours and two minutes. Mr. McDaniel's view of the outside world

# THE WORLD OF INVENTION

A portable vacuum cleaner for horses. This new apparatus was exhibited by a Swiss firm at the Basle Fair, Switzerland.

## By Submarine to the Pole

**SIR HUBERT WILKINS**, the famous explorer, is, despite the war, still carrying out experiments with a "pocket submarine" in which he hopes to sail under the Arctic ice.

He plans to set up a weather station near the Pole, and hopes to sail from Fort McMurray, 200 miles north of Edmonton, through the rivers and lakes of Northern Canada to the Arctic. The submarine will cost about £9,000 and will take about two months to build.

## Fire-fighters' Flame-proof Suit

**FIRE-FIGHTERS** at Royal Air Force Stations can walk through flames with safety. At every air station flameproof suits are ready for instant use whenever flying is in progress. The airmen are always on duty with the fire-tender wearing the lower portion of the flameproof suits.

These Royal Air Force fire suits are designed to enable the wearer to work unimpeded in a serious fire. Unlike suits made entirely of asbestos, these are light. They have silk linings.

The various portions—trousers, boots, jumper, gauntlets and helmet—have been carefully planned so as to facilitate rapid adjustment and easy storage on the fire-tender.

## New Discovery in Egypt

**AT San el Hagar**, recently, an intact tomb of an early Egyptian King was found. This is the third time in modern archaeological history that such a discovery has been made. With the assistance of King Farouk. Professor Montet, the French Egyptologist opened the tomb next to that of King Psousennes, which was discovered last February. King Amenemote, whose sarcophagus was in the tomb, reigned about 1,000 B.C. He was of the 22nd Dynasty. San el Hagar is the ancient City of Tanis, which was built as a holiday resort in the Nile delta about 3,000 years ago by Rameses II. Infiltration of the sea had ruined most of the visible objects, except a massive gold vase. On the sarcophagus were a lovely golden mask, gold hands with a sceptre, and a golden bird.

## Kite to Aid Airmen

**MR. GEORGE TUCHTEN**, of Pretoria, has invented a new type of kite with a luminous attachment. This operates either as a beacon for aeroplanes or may be used for signalling purposes. He claims that his invention will be useful when pilots make forced landings in sparsely populated country. They could reveal their position to searching planes up to 100 miles away, by sending up the kite. Ships that are in distress, and not equipped with wireless, can also use the kite. Attention can be attracted by means of a buzzer attached to the kite, and at night a light may be used for Morse signalling operated from the ground.



## Precision Measurement

**A MACHINE** which works to an accuracy of one-one-hundred-thousandth of an inch is one of the wonders of the Lucas factory in Birmingham. It is known as the universal measuring microscope. The machine stands in a room by itself and is about the size and weight of a small lathe. It has five powerful lenses which enable any article under examination to be thoroughly scrutinised from every angle, and the minutest discrepancy can be detected instantly. Its main purpose is to check fine gauges.

## A New Unit Air Heater

**A NEW** design of unit heater has been produced consisting essentially of a heater battery and fan enclosed in a shell. Adjustable louvres are incorporated on the outlet side. Due to the horizontal extension of the outlet side, a very effective distribution of warm air is obtained over the horizontal plane. The direction of the air leaving the heater can be controlled to suit the mounting height employed, by adjustment of the louvres.

Unit heaters are particularly suitable for use in factories, warehouses, garages and similar places, owing to the high loading of individual heaters which is permissible with this system. The cost of installation is substantially lower than with other direct systems of heating.

## R.A.F. Shooting Practice

**THE R.A.F. gunners** are learning to shoot by means of a turret equipped with an ordinary shot-gun instead of the usual four machine-guns. Clay pigeons are launched and the gunner shoots at these, working the turret exactly as he would in an aerial combat. Another method makes use of a darkened aircraft shed in which are power-operated turrets. A spotlight is focussed on the wall and roof of the shed and made to move slowly along. The gunners have to train their sights on it. It is found that by these means very great improvements can be secured in a short time.

## Movable Partitions

**THE** evacuation of staffs to the country must, we imagine, in some cases necessitate alterations to make a mansion suitable for the role of an office. For instance, a drawing-room may require to be converted into twin rooms. To accommodate this necessity, a newly designed movable partition wall should be a godsend. Its composition includes asbestos cement, and an ingenious connecting arrangement makes dismantling and placing in some other position as simple as the original erection.

Although the walls and doors of these partitions are only 1½ inches thick, they possess a high degree of resistance to fire. And noise does not easily penetrate them. Consequently, the secrets of the management, or those of the typists, would find some difficulty in percolating from one department to another.

## THE "FLYING SUITCASE"

**THE** Handley Page Hampden, which is one of the fastest medium bombers in the world, has recently been giving a good account of itself in attacks on enemy seaplane bases and reconnaissance flights over Germany.

In appearance this aircraft is unusual; and so is its method of construction. The narrow fuselage is of a deep section in the forepart and tapers rapidly to a slim tail boom. The unusual silhouette, seen from the side, has earned it the name of the "flying suitcase." Built on what is known as the split construction system, the whole of the Hampden is split up into small units, thus providing the means of rapid assembly.

The Hampden is an all metal, mid-wing

monoplane capable of carrying a very big load for a long distance at high speed. Fitted with two Bristol Pegasus engines each of approximately 1,000 h.p., it has a cruising speed of about 220 m.p.h. and a maximum speed of 265 m.p.h. The maximum range approaches 2,000 miles. The wing span is 69 ft. 4 ins., the overall length 53 ft. 4 ins., and the all-up weight 8½ tons, of which over 3 tons is "useful load." A crew of three or four is normally carried.

In common with other British aircraft, the defensive armament of the Hampden type has been considerably strengthened since the outbreak of war, giving it a formidable defence against enemy aircraft.

# Chemistry for Beginners

No. 15.—Further experiments in Organic Chemistry—Some  
Interesting Acids and their Compounds

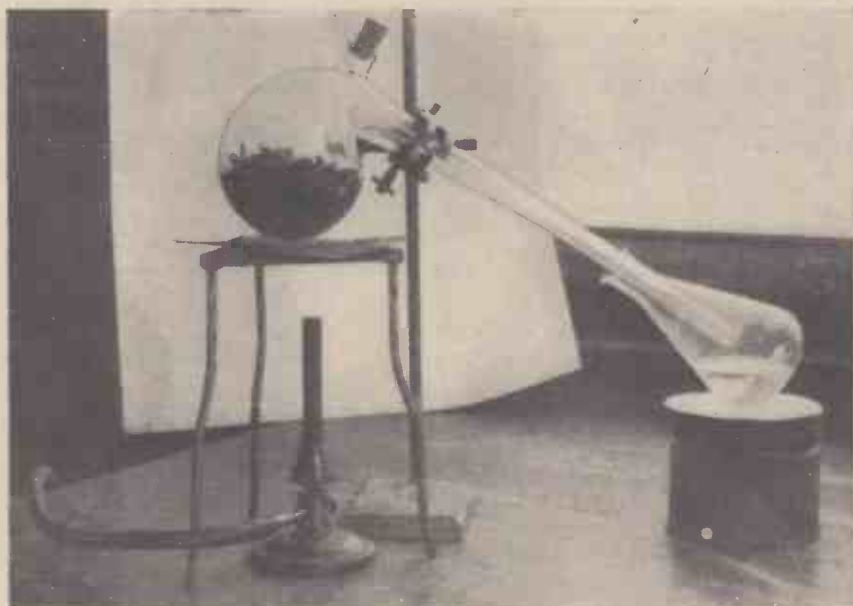

Distilling fresh nettle leaves with water in order to prepare dilute formic acid

**T**HERE exists a very large group of acidic substances known as the "fatty acids," these compounds being so called on account of the fact that some of them, such as stearic and palmitic acids, are present in natural fats and very closely resemble fats in their properties.

The very simplest of the fatty acids, and, perhaps, one of the most interesting of the whole group, is formic acid, a material which any amateur can prepare in his laboratory, at least in a dilute state. Formic acid is the acid of nettles and of ants. Indeed, its name, formic, comes from the Latin, *formica*, an ant, for this acid is secreted by ants, which fact explains the peculiar acidic odour which is often present in the vicinity of an ants' nest. Again, the minute stinging hairs of the common nettle are highly charged with formic acid among other substances, and when the bulbous tips of these hairs are rubbed off by contact of the skin with the nettle, the sharp points of the hairs just penetrate the surface skin and inject a minute quantity of formic acid into it, which fact accounts for the peculiar redness and tingling of the nettle-stung skin.

#### Making Formic Acid

Formic acid has the chemical formula,  $\text{H.COOH}$ . Note particularly the " $-\text{COOH}$ " portion of this formula, because all the fatty acids contain this latter atomic grouping.

To prepare a dilute solution of formic acid in the home laboratory, all we have to do is to collect a handful of nettles, chop them up under water, and then put the entire mass of water and nettles into a retort and gently distil the liquid. A clear solution of formic acid will pass over and will collect in the receiver. This will comprise merely dilute formic acid, yet in many instances it will be sufficiently strong to dissolve metallic carbonates, such as

sodium and zinc carbonates, with the formation of the respective formates.

To make a stronger solution of formic acid we must distil very gently a mixture of approximately equal parts of oxalic acid and glycerine at a temperature just over the boiling point of water. At this temperature carbon dioxide gas is evolved from the mixture and dilute formic acid distils over.

It is a difficult matter for the amateur to prepare absolutely pure and water-free formic acid. However, this may be accomplished by dissolving lead carbonate (white lead) in the dilute formic acid, and by filtering and evaporating the resulting solution of lead formate. The crystals of lead formate which are thus obtained and put into a bulb tube and a stream of sulphuretted hydrogen is passed over them, the lead formate being gently warmed at the same time. In this manner, lead sulphide is formed, which remains as a black mass in the bulb tube, and pure formic acid collects in the receiver as a powerfully acidic liquid, which quickly corrodes and blisters the skin if it is allowed to make contact with it.

#### Metallic "Formate"

Formic acid, in common with all the other "fatty" or "carboxylic" acids,

dissolves metallic hydroxides and carbonates with the formation of metallic formates. In this reaction the hydrogen atom of the  $-\text{COOH}$  group is replaced by a metallic atom. Thus:



Formic acid Sodium formate

This formation of salts is characteristic of all the acids of the group with which we are dealing. For instance:

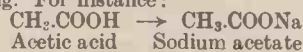

Acetic acid Sodium acetate

and:

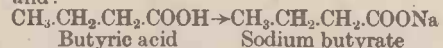

Butyric acid Sodium butyrate

We can, therefore, make any common metallic "formate" or salt of formic acid merely by dissolving the carbonate of the metal in the hot dilute formic acid, and then by evaporating the resulting solution down to crystallisation point. Sodium formate, therefore, may be made by dissolving carbonate of soda in the hot weak formic acid, whilst the brilliant blue copper formate is obtained by dissolving copper carbonate or hydroxide in the acid. Ammonium formate is prepared by neutralising ammonia with formic acid.

This ammonium formate is a very interesting salt because on being heated to about  $230^\circ\text{C}$ . it becomes converted into an entirely different compound known as *formamide*,  $\text{HCONH}_2$ .

Formic acid, in even weak solution, has the power of converting silver solutions into metallic silver. If, for instance, to a solution of silver nitrate we add a little ammonia and then a few drops of formic acid and gently warm the liquid, the latter will rapidly darken with the formation of metallic silver as a black insoluble powder. Sometimes, also, the silver will be precipitated on the sides of the vessel in the form of a brilliant silver mirror.

#### Acetic Acid

The next acid after formic acid in the "fatty" or "carboxylic" series is acetic acid which is present in vinegar to the extent of anything between 5 and 10 per cent.

We may make acetic acid from vinegar by neutralising the vinegar with carbonate of soda and then by evaporating the resulting solution of impure sodium acetate down to dryness. The impure sodium acetate is then placed in a retort, covered over with strong sulphuric acid and distilled, whereupon acetic acid will collect in the receiver.

When wood is heated strongly out of contact with air, tar and other liquors are formed, which latter contain acetic acid.

Acid	Formula	Melting Point	Occurrence
Formic	$\text{H.COOH}$	$+8.3^\circ\text{C}$ .	Nettles. Ants.
Acetic	$\text{CH}_3\text{COOH}$	$+16.5^\circ\text{C}$ .	Vinegar. Wood tar.
Propionic	$\text{C}_2\text{H}_5\text{COOH}$	$-36^\circ\text{C}$ .	Wood tar.
Butyric	$\text{C}_3\text{H}_7\text{COOH}$	$-4^\circ\text{C}$ .	Rancid butter. Perspiration.
Valeric	$\text{C}_4\text{H}_9\text{COOH}$	$-59^\circ\text{C}$ .	Valerian and Angelica roots.
Heptylic	$\text{C}_6\text{H}_{13}\text{COOH}$	$-10.5^\circ\text{C}$ .	Animal urine.
Lauric	$\text{C}_{11}\text{H}_{23}\text{COOH}$	$+43.6^\circ\text{C}$ .	Croton oil.
Myristic	$\text{C}_{13}\text{H}_{27}\text{COOH}$	$+54.0^\circ\text{C}$ .	Seeds.
Palmitic	$\text{C}_{15}\text{H}_{31}\text{COOH}$	$+62.0^\circ\text{C}$ .	Animal fats.
Stearic	$\text{C}_{17}\text{H}_{35}\text{COOH}$	$+69.0^\circ\text{C}$ .	Animal fats

This table gives at a glance the formulae of some of the better-known natural fatty acids.

# MY TRADE'S BOOMING

**Says this  
RADIO  
SERVICE  
MANAGER**



**A BIG OPPORTUNITY  
TO-DAY**

WITH the call-up affecting many thousands of Radio engineers, and wireless playing an increasing part on the Home Front and in the Services, Radio Service Managers are at their wits' end to-day to keep pace with the work in hand. Husbands and brothers who normally knew enough about wireless to diagnose and correct simple troubles of the family set, are away in the Forces, and women send for service men when their set "goes wrong". Servicing is only one of the many busy branches of modern radio, and the industry provides a golden opportunity for youths leaving school and others to learn a remunerative trade. One may study it by reading the following important radio books, which form a complete sequence of authoritative instruction in radio practice to-day. If you are a father, consider radio for YOUR son! Get the set, or singly in the order given.

The following practical books are by **F. J. CAMM**  
(Editor of *Practical Wireless*)

**THE PRACTICAL WIRELESS ENCYCLOPAEDIA**  
Wireless Terms and Definitions stated and explained in concise, clear language. 392 pages. Over 500 illustrations. 7s. 6d. net. (By post 8s.)



**EVERYMAN'S WIRELESS BOOK**  
A Radio Consultant for all, explaining the Operation, Upkeep and Overhaul of all types of Wireless Receivers. 200 illustrations and diagrams. 5s. net. (By post 5s. 7d.)



**SIXTY TESTED WIRELESS CIRCUITS**  
Modern circuits of every type. Diagrams and instructions for assembling and wiring. Details of components and notes on operation. 3s. 6d. net. (By post 4s.)

**PRACTICAL WIRELESS SERVICE MANUAL**  
A complete work on the testing and servicing of all types of wireless receivers. Packed with information. With over 220 illustrations. 288 pages. 6s. net. (By post 6s. 7d.)

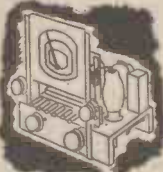

**NEWNES' SHORT-WAVE MANUAL**  
Deals thoroughly with the problems underlying the design of short-wave apparatus, the special circuits which yield the best results, and designs for receivers based on those circuits. 5s. net. (By post 5s. 7d.)

**WIRELESS TRANSMISSION FOR AMATEURS**  
Covers fully and clearly the whole field of wireless transmission. With 120 illustrations. 3s. 6d. net. (By post 4s.)

**WIRELESS COILS, CHOKES AND TRANSFORMERS**  
For every home constructor. 126 illustrations. 3s. 6d. net. (By post 4s.)



Of all Booksellers, or by post from the Publishers:  
George Newnes, Ltd. (Book Dept.), Tower House, Southampton Street,  
Strand, London, W.C.2.

## ENGINEERING WORKSHOP PRACTICE

This up-to-date book provides a complete practical course of instruction in every important branch of engineering workshop methods, materials and equipment. It deals with the underlying principles, craftsmanship, machines, tools, measuring processes and machining methods of to-day, and it will prove indispensable to the engineer, draughtsman, mechanic, apprentice and engineering student. Its scope extends from simple hand tools and machines to the latest elaborate machines and methods employed for mass-production purposes.

### SOME OF THE SUBJECTS

Files, Chisels, Scrapers, Shears, Punches, Burnishers, Hand Screw-cutting Tools, Spanners, Vices, Various measuring methods. Verniers, Micrometers, Gauges, Optical Devices, Fluted and Twist Drills, Grinding Angles, Drilling Data, Small and Large Drilling Machines, Electric Drills, Practical Lathework in all its branches. Machining of Metals and Synthetic Materials. Tungsten-carbide and Diamond Tools. Lapping, Honing, Cleaning, Polishing and Rust-protection of various metals. Grinding Operations and Machines, Milling Operations, Cutters and Machines. Planing, Shaping, Slotting and Broaching Operations. Special Machines for Production Purposes. Plate and Bar Machines. Gears and Gear cutting Methods. Templates, Jigs and Fixtures. Overhauling and Adjusting Machines, Millwright Work. Welding, Brazing and Soldering Metals. Forging Work. Sheet Metal Work. Foundry Work. Patternmaking Practice. Press Work. Engineering Steel and other Metals; their Properties, Testing. Hardening, Tempering and Annealing. Engineers' Drawings. Workshop Calculations, Data, Hints and Recipes.

### THE ILLUSTRATIONS

The book is lavishly illustrated so that the explanations are rendered very clear with examples taken up from actual works practice in many instances. There are 24 full-page plates and 877 line and photographic illustrations in the text.

### ENGINEERING POCKET BOOK

In order to make the work even more comprehensive, we have brought out a pocket book, which is supplied free to all purchasers. It contains many useful tables of Screw Threads, Tapers, Angles, Drill Speeds and Sizes, etc.

### A FREE BOOKLET

To the Caxton Publishing Co., Ltd.,  
119 Clun House, Surrey Street,  
London, W.C.2.

Please send me, free of charge, Illustrated Booklet describing "Engineering Workshop Practice."

Name.....  
Send this form in unsealed envelope or a postcard.

Address.....

G.25. ....

# YOUR LAST CHANCE!

To Obtain AT LESS THAN HALF PRICE

## "MOTOR ENGINEERING"

A comprehensive, accurate and practical work in  
**4 VOLUMES**

Written and compiled by thirty-five experts.  
Indispensable to Motor Engineers, Motor Mechanics  
and Owners of Garages and Service Stations.  
ONLY A FEW SETS LEFT.

**THE BIGGEST BARGAIN FOR YEARS!**

OUR offer of "MOTOR ENGINEERING" for only £2 2s. instead of £4 10s., has brought hundreds of orders from all parts of the country. Garages everywhere are busy servicing cars several years old—cars that will be kept on the road for many months yet—and "MOTOR ENGINEERING" with its expert guidance on repair work for cars and commercial vehicles (1931-7) has been snapped up for the amazing bargain it is. The number of sets left becomes smaller every day, and you are advised to obtain yours immediately if you wish to avoid disappointment. A set will be sent to you on receipt of a first payment of only 2/-. or the complete cash price of £2. Fill up the coupon below now.

### THIS IS WHAT YOU RECEIVE:

**4** Substantial Volumes in Attractive Moroquette—strongly bound for years of wear. They cover the whole subject of Motor Engineering:—Vol. I: ENGINES—Overhauling, Repair and Testing. Vol. II: ELECTRICAL—Equipment and Accessories. Vol. III: CHASSIS—Bodywork, Brakes and Braking Systems. Vol. IV: TRANSMISSION—Clutches, Gearboxes, Universal Joints, Differentials, Rear Axle and Steering Repairs.

Every contributor is an expert—many of them with the biggest car and commercial vehicle firms. Thousands of photographs are included to show the correct sequence of operations. These operations represent the latest practice.

#### Special Chart Case Containing:—

**47** ENGINE TIMING CHARTS covering upwards of 1,000 models of 47 different makes of cars and commercial vehicles, including (1931-7): A.E.C., Alvis, Armstrong-Siddeley, Austin, B.S.A., Buick, Bugatti, Chevrolet, Chrysler, Citroen, Commer, Daimler, Dennis, Ford, Gilford, Guy, Hillman, Hudson, Humber, Jowett, Lanchester, M.G., Morris, Morris Commercial, Reo, Riley, Rover, Scammell, Singer, Standard, Thornycroft, Triumph, Vauxhall, Wolseley, etc., etc.

**24** BLUEPRINTS OF BRAKE LAY-OUT DIAGRAMS dealing with 34 makes and 55 models.

**2** COLOURED MOVABLE MODELS of an Ignition-Compression Engine (Diesel) and a Lucas Combined Cut-Out and Voltage Regulator.

**FREE!** Two-Year Motor Engineering Advisory Service. This entitles you to guidance on any branch of modern motor engineering. The information you require may cost us pounds—but these authorities are at your disposal for **TWO YEARS!**

## HOW TO ORDER

All you do is fill up the Order Form on right and send with Postal Order for 2/- to the address given. You may, if you wish, send the complete purchase price of £2 instead of agreeing to pay eight monthly instalments of 5/-.



WITH THOUSANDS OF PHOTOGRAPHS

● If you do not wish to cut your "Practical Mechanics," copy the wording from the coupon below on to a sheet of paper, add your name and address, and send together with P.O. for 2/- to address given.

### SENT TO YOU CARRIAGE PAID FOR ONLY

Post AT ONCE to

MOTOR ENGINEERING (H.L.B.C.),

**2/-**

Tower House, Southampton Street, Strand, London, W.C.2.

Please send me, carriage paid, MOTOR ENGINEERING. I enclose Postal Order 2/- No..... I agree to remit a further 8 monthly subscriptions of 5/- to complete the purchase price of £2 2/-.. Cash price with order £2.

Name.....

Address.....

Occupation..... Age..... P.Mech.040



The distillation of wood for the production of acetic acid on a laboratory scale is an almost hopeless experiment, and, therefore, we shall not waste space with its description. Suffice it merely to say that the vapours from the distilled wood are passed into milk of lime, whereby calcium acetate is formed and subsequently extracted and converted into acetic acid by distillation with concentrated hydrochloric acid.

Pure acetic acid is a liquid at normal room temperatures but it very readily congeals to a mass of ice-like crystals even when very moderately cooled. For this reason, the pure acid is generally known as *glacial acetic acid*.

The acid has a powerful and penetrating vinegar-like smell, and it tends to corrode the skin when allowed to make contact with it. Just as metallic carbonates and hydroxides produce metallic *formates* when dissolved in formic acid, so, too, carbonates and hydroxides form *acetates* when they are dissolved in acetic acid.

#### Acetate Formation

The practical technique of acetate formation is precisely the same as in the case of making formates. Some acetates are very important compounds. Aluminium acetate for instance, can be used as a waterproofing agent. Lead acetate is known commonly as "sugar of lead" on account of its sweet taste. But it should on no account be tasted, since it is very poisonous. Copper acetate is a dark green crystalline salt. In certain forms it is known as *verdigris*, and it may readily be produced by leaving strong vinegar or acetic acid in contact with sheet copper for a few days.

Just as ammonium formate, when slowly heated, gives formamide,  $\text{HCONH}_2$ , when slowly heated and distilled, so, also, ammonium acetate produces *acetamide*,  $\text{CH}_3\text{CONH}_2$ , when it is heated to about  $140^\circ \text{C}$ . This acetamide, which forms colourless crystalline needles, melting at  $82^\circ \text{C}$ ., is a rather curious substance in regard to the fact that, as ordinarily prepared in the manner described, it possesses the astonishing smell of mice! Actually, however, this characteristic smell is due to the presence of a small trace of some unknown impurity in the acetamide.

When heated with hydrochloric acid or with caustic soda, acetamide is converted into ammonia and acetic acid.

The next acid on the list of "fatty" acids is propionic acid,  $\text{CH}_3\text{CH}_2\text{COOH}$ . This, however, is of little practical interest and importance. It is, also, difficult to make.

Of much more interest is butyric acid,  $\text{CH}_3\text{CH}_2\text{CH}_2\text{COOH}$ , which is present in rancid butter and cheese.

#### Butyric Acid

It is an interesting task to make butyric acid from natural sources in the following way:

Milk is left exposed freely to the air until it turns completely sour, which it does owing to the contained milk-sugar becoming converted into lactic acid by means of an organism, the *lactic ferment*, which is everywhere present in the air and which falls into and contaminates the fresh milk. Expressed briefly, we may write:

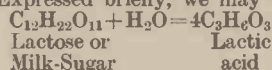

When the milk has turned thoroughly sour, a little decaying cheese is added to it, together with a quantity of precipitated chalk.

Now the decaying cheese also contains an organism, the *butyric ferment*, which has

the power of converting the lactic acid into butyric acid, carbon dioxide and hydrogen:

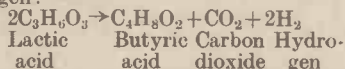

This butyric ferment, however, is killed in the presence of acid. Hence the addition of the chalk (calcium carbonate) to the milk mixture. This neutralises the butyric acid as soon as it is formed, producing calcium butyrate.

Most of the butyrates, or salts of butyric acid, are soluble in water, but calcium butyrate is a very peculiar salt in respect of the fact that it is more soluble in *cold* water than it is in hot water. Thus, by filtering the liquor resulting from the milk mixture, after the mass has been allowed to stand for a fortnight or three weeks, and subsequently by boiling it, the liquid will precipitate calcium butyrate, which is not very soluble in hot water. This salt, when carefully distilled with sulphuric acid, gives butyric acid, which, when pure, is a thick liquid possessing a very sour smell.

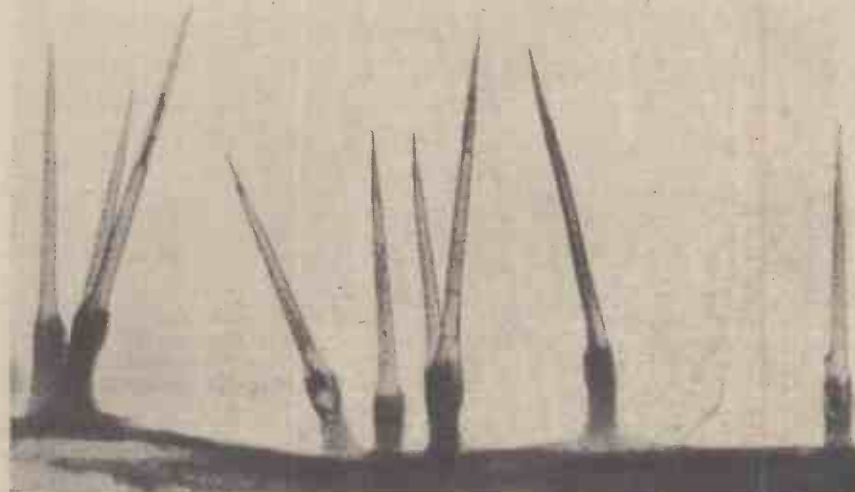

A portion of a nettle leaf seen under a powerful microscope. Note the sharp hairs which contain formic acid and which are capable of injecting it under the skin, thus setting up a "nettle sting"

Another way of preparing butyric acid is to melt butter (about 25 grams of it) and then to add to the mass 60 ccs. of methylated spirit and 10 grams of caustic soda. The mass is heated gently until a clear solution is obtained. It is then more strongly heated to expel the methylated spirit. Finally, it is distilled with sulphuric acid. The distillate will have a very sour and disagreeable smell, since it will be contaminated with other acids besides butyric acid. However, it should be neutralised with sodium carbonate and boiled with calcium chloride solution, whereupon white calcium butyrate will be precipitated. This is then filtered hot and finally distilled with sulphuric acid to obtain butyric acid.

Metallic butyrates are obtained in precisely the same manner as acetates and formates, with which latter they have most properties in common.

Palmitic acid,  $\text{C}_{15}\text{H}_{31}\text{COOH}$ , and stearic acid,  $\text{C}_{17}\text{H}_{33}\text{COOH}$ , are other well-known members of the fatty acid series of compounds. These occur in vegetable and animal fats combined with glycerine.

Take, for instance, beef or mutton suet. When this is kneaded in a cloth bag under hot water, the fat melts and passes out of the bag, leaving merely the animal membranes and connective tissues behind. When the melted fat is cooled down and solidified it is known as *tallow*.

Now, when tallow is heated with dilute

sulphuric acid, or with water under pressure, it is decomposed into glycerine and a mixture of stearic, and palmitic and a few other fatty acids. Other animal fats, such as butter, goose-fat, lard, cotton-seed and olive oils, behave in a similar way, giving rise to glycerine and the constituent fatty acids, chief among which are the almost universal stearic and palmitic acids. (In the case of olive oil, oleic acid is produced.)

The mixture of fatty acids usually is found floating on the surface of the liberated glycerine. Hence, the mixture is submitted to a form of pressing through cloth or canvas, whereupon the glycerine passes through, leaving the fatty acids behind. They are purified by crystallisation from alcohol.

When a vegetable or animal fat is heated with an alkali, such as a solution of caustic soda, the liberated fatty acid immediately combines with the alkali forming the sodium salt of the acid which is a soap.

Thus, for instance, if tallow is heated with caustic soda solution, glycerine and stearic

acid are set free. The glycerine remains unattacked, but the caustic soda and the stearic acid at once react together, forming sodium stearate, a material which is soluble in water and which is, in fact, a soap. Upon these principles the whole of soap-making is based.

By adding a solution of an aluminium or a copper salt to a solution of stearic acid or sodium stearate, the well-known waterproofing agents, aluminium stearate and copper stearate, are produced.

## THE FLYING REFERENCE BOOK

By F. J. GAMM

—is a complete guide to all types of aircraft, which is especially valuable at the present time.

It is packed with facts and figures relating to all branches of flying.

The second edition, just off the press, is right up to date.

Price 5s. from all booksellers, or 5s. 6d., by post from the Publishers, C. Arthur Pearson, Ltd., Tower House, Southampton Street, Strand, London, W.C.2.

# "MOTILUS" PEEPS INTO THE

## Our Model Expert Reviews



*A Bassett-Lowke high-pressure, internally fired model of the Royal Scot that went to America*

As the war progresses, there is certain to be a gradual restriction on the use of all essential materials. But it appears to me that the hobby of model-making will not ever suffer as much as some of the other hobbies. In the first place, the amount of actual materials used in model-making is negligible, and there is generally odd material to be picked up at dealers and model shops in various parts of the country. As far as standard materials are concerned, like railway chairs, castings, rod and tube metal, especially where special sections are required, there is no doubt difficulty will increase as time goes on. Most of the model firms are being allowed by the Ministry of Supply 60 per cent. of their pre-war quantities, but some of this must be cancelled off against the export trade to obtain the foreign credits so much needed in these days. As far as prices are concerned, these are steadily rising, and although in some cases the increase is not more than 10 per cent., in electrical equipment, transformers, rectifiers, etc., the rise is much steeper. Certain metals are under Government control, and therefore the price of these has not risen substantially, but in most cases we have to face the undoubted fact that the price of the finished article is affected owing to increase in labour, overheads, and war-time insurances, etc.

### The "Lion"

Several of my friends in the model world have asked me about the old locomotive of the Liverpool and Manchester railway—the "Lion"—which now stands in a place of honour between platforms 3 and 4 at Lime Street Station, Liverpool. As so many people use this well-known terminus, these details are of fairly general interest, so here they are:—

The "Lion" was built for the Liverpool and Manchester Railway in 1838 by Messrs. Todd, Kitson & Laird, of Leeds, and was probably the first engine made by that firm. It was No. 57 of that railway, and was taken over with other stock by the Grand Junction Railway in August, 1845. Upon further amalgamation it became No. 116 of the London and North Western Railway, which by the Railways Act of 1923 became a constituent Company of the L.M.S. The "Lion" became the property of the Mersey Docks and Harbours Board

in 1859 and worked as a pumping engine at Prince's Graving Dock from then on until August, 1928, when it was presented to the Liverpool Engineering Society, so that it might be preserved for the City of Liverpool. It was restored during 1938 in the L.M.S. shops at Crewe, with the assistance of Mr. J. G. H. Warren, an authority on early locomotive design. The engine is of Robert Stephenson's patent type 1833-1840, with outside sandwich frames of wood between iron plates, and inner frames of wrought iron to carry crank axle bearings. The frames, cylinders, valve and driving gear, wheels and axles are original, and the "Lion" is probably the only locomotive still in working order having the original gab valve motion. The present boiler is of later date, lagged in the style of the period, and the restored engine as a whole represents a type in use on British railways from 1838 to 1848. The tender is not original, but has been adapted from an early tender from the Furness Railway. During the Centenary celebrations of the Liverpool and Manchester Railway, held at

Liverpool in 1930, this interesting old engine worked the "Train of 1830" and carried 18,853 passengers on the Ring Railway which had been specially laid down at Wavertree.

### A Peculiar Model Railway

One comes across some peculiar model railways in one's time, but I have never seen one before that bore a resemblance to a roundabout scenic railway, like we see at seaside resorts, but here is a picture of one built in this style by Mr. R. Hancock, of Balmain, New South Wales. One could have wished, however, that a British model railway could have been used for this display. As you will see, it is an American firm's work—the Lionel Corporation.

### Steam Motor Coach

I paid a visit recently to Mr. Victor B. Harrison's famous Gauge 1 railway at Bishop's Stortford, and was very interested to see that, despite the war, he is making further additions to his line, one of these being a steam motor coach and trailer which is quite unique, I believe, in model railway equipment. Mr. Harrison has no fewer than 36 locomotives, of which 18 are by Bassett-Lowke, seven by Bonds, five by Campbell, and three the work of the owner. His main line run is 430 feet, and with branch line, sidings and other running lines, mounts to the large total of nearly 1,200 feet of track on this magnificent Gauge 1 railway.

### Models from Belgium

As I write the eyes of the world are on the little countries of Europe, and I have recently received from Belgium several pictures of models made to scale in Brussels by the Chemins de Fer, Aviation, Marine.

The illustration shows one of the powerful 4-6-2 Belgian express locomotives used on the fast service between Ostend and Brussels and designed by the famous locomotive engineer Monsieur Flamme. Resting on the footplate is a model of the same locomotive to a scale of 1 in 30, approximately the same size as our Gauge 0. The second

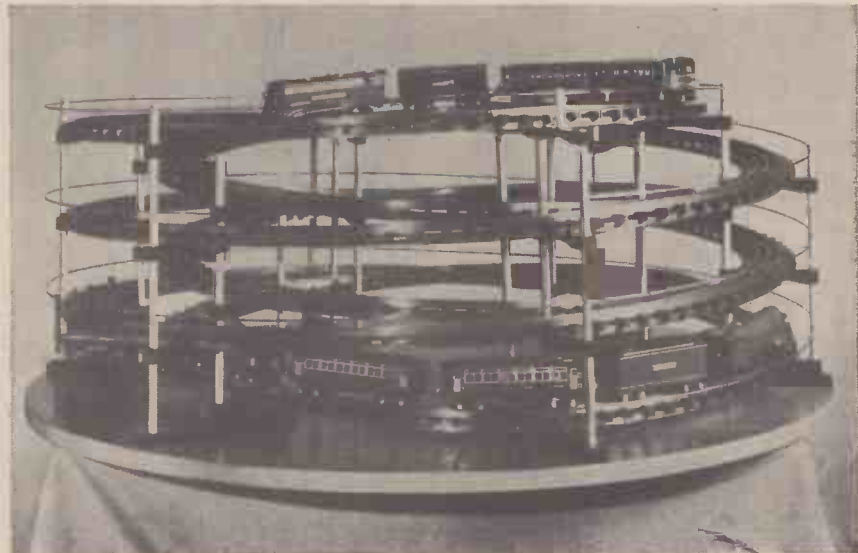

*The roundabout scenic railway—an American-made novelty in Australia*

# MODEL WORLD

## The War-time Position Of Model Makers

is a model of the new railway station at Blankenberg, built to a scale of 1/50th. It is an exterior view, carried out in attractive modern style and showing the Post Office on the corner.

### A Model Tractor

An interesting model is the 50 years old "Eclipse" tractor which was built in the shops of the Frick Manufacturing Company of Pennsylvania in 1889. The Americans make the "Eclipse" tell his own story in this way. "I, next to my big brother the locomotive, was the wonder of my time, for I could move about on my own power. I had the advantage over the locomotive for I needed no rails and no roads. I made my own. I worked hard from early morning to late at night, and all I needed was fire

The 4-6-2 Belgian express with model on the footplate



wherever power was needed for turning machinery, but for a long time some of the farmers would not have me around for fear my boiler would blow up or that my belching smoke and cinders would set fire to their buildings. My life was about 25 years,

1 1/2 inch — 1 foot. My boiler capacity is three pints of water, and my rated horsepower is about one-eighth. This building of my likeness represents the combined efforts of the instructors of Industrial Arts, student teachers, and over 400 students of the Washington Junior-Senior High School, Washington, Pennsylvania. My boiler was made by the O'Brien Construction Company, and this work was made possible by the special permission and co-operation of the Department of Labour and Industry, Harrisburg, Pennsylvania." Quite a novel way of introducing a model's history!

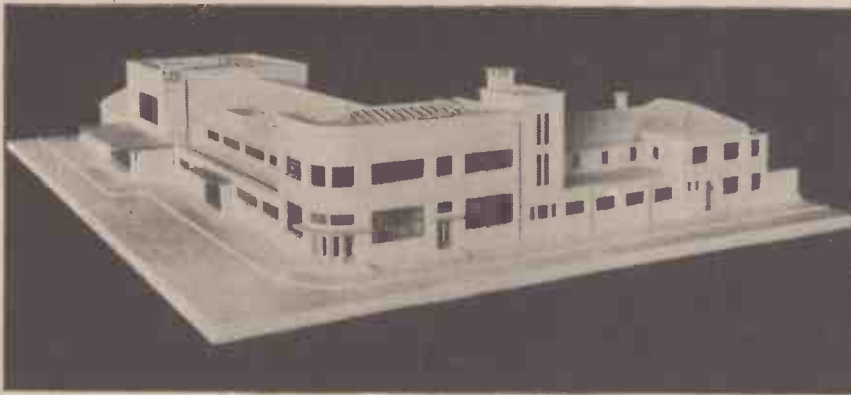

A model of the railway station at Blankenberg

to make the steam, water to cover the crown sheet, and tallow or lubricating oil for my valve gear and cylinder walls. If the roads were dry and not too steep I could travel at the rate of 2 1/2 m.p.h. I was faster than the old horsepower for threshing grain or

but in all this time I fed the hungry. I sawed the timber for the barns and houses, and I helped to make the roads for the automobile. In fact, I am the forerunner of the automobile.

In this model I am built to a scale of

### Trix Twin Layout

I am often asked by those who are contemplating a Trix Twin Railway to suggest what I think is an ideal layout for a space of about 12 feet by 6 feet, and here is a suggestion for the space mentioned. It consists of a double road with a small terminus station, a through station with bay and ample provision in the way of sidings for spare locomotives and rolling stock. It could also incorporate a high-level section by the use of "Lowko" gradients and a high-level station. The controls, locking frame, wiring diagram are also given, and I suggest the operator's well should be in the centre about 3 feet by 2 feet. The numbers given on the station and buildings are the Trix standard "Many Ways" units.

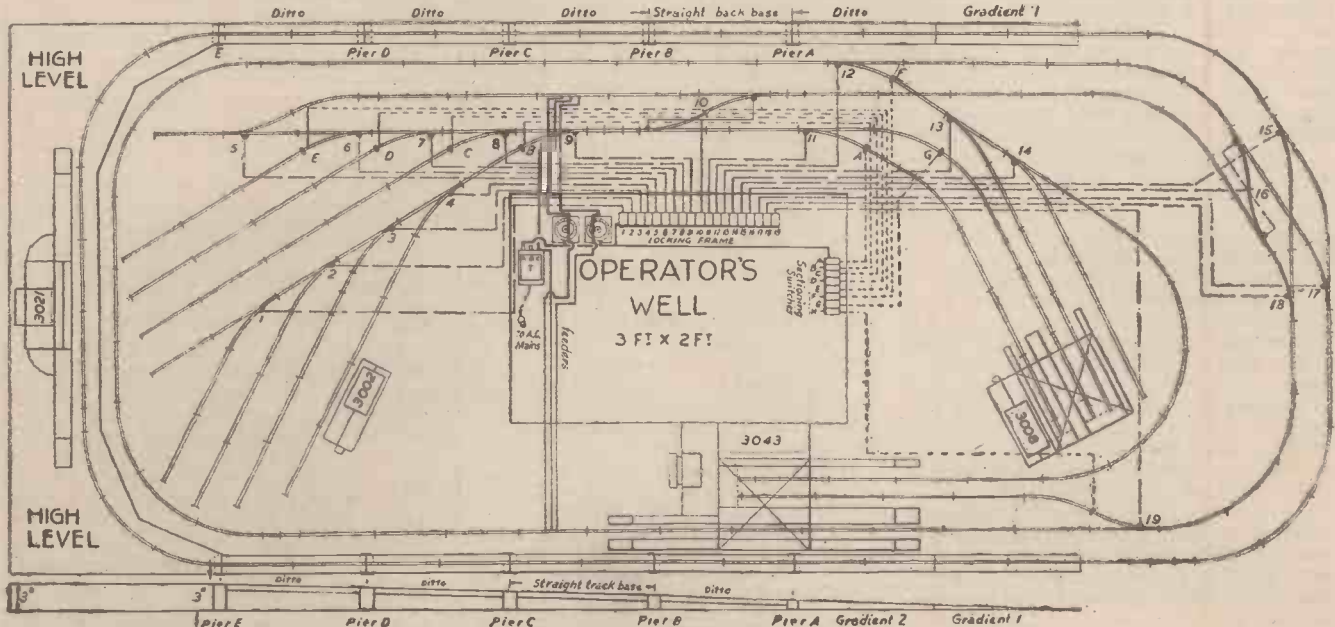

A suggested lay-out for your Trix Twin layout—for a space approximately 12 ft by 6 ft.

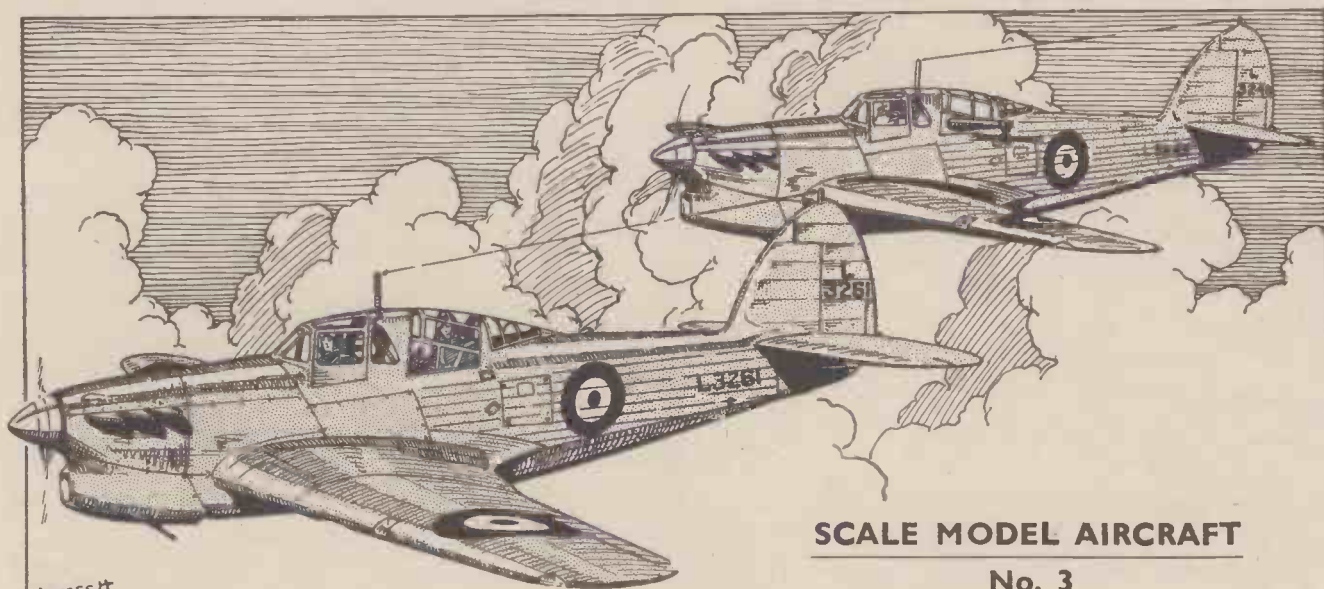

## SCALE MODEL AIRCRAFT

No. 3

# The Hawker Henley

By J. H. Stevens, A.R.Ae.S.

## An R.A.F. Light Bomber which has been Converted for High-speed Target Towing

**T**HE Hawker Henley is the youngest scion of a distinguished line of two-seaters to see service with the R.A.F., R.F.C. and R.N.A.S. The earliest of these were the Sopwith landplanes and seaplanes, mainly converted sporting types, which were used in the early days of the last war. They were followed in 1916 by the first tractor two-seater fighter, the "One-and-a-half Strutter," which, although rather underpowered, did magnificent work during 1916-1917. For the rest of the War the Sopwith Company was best known for its single-seater fighters. After the War the company was re-formed and the present name of "Hawker" (after the firm's chief test pilot and engineer Harry Hawker) was adopted to carry on the Sopwith tradition. The first post-war two-seater type to be used in quantity was the Horsley, a single-engined, long-range day bomber.

### The Famous Hart

This was followed in 1929 by the famous Hart. To do more than mention the Hart and its many variants, the Osprey, Audax, Demon, etc., would be superfluous; but it is worth remembering that it was the Hart, more than any other aeroplane, that broke the old wartime tradition of the "120 m.p.h. two-seater." For a time the Hawker company concentrated upon the development of the Hart and in the production of the various types of Fury until, in 1936, they brought out the Hurricane and, in the following year, the Henley, to Air Ministry Specification P4/34.

In the time that elapsed between the appearance of the prototype Henley and the arrival of the production machines the authorities apparently decided that it would be easy to dispense with the light bomber as a type.

### Target Towing

The result was that the machines were turned over to the duty of target-towing—a necessary, but somewhat degrading work for a good and warlike aeroplane. However, a high-speed target was badly needed for the training of both air crews and anti-aircraft gunners because the radio-controlled Queen Bees, although adequate in their way, and the Gordons and Harts previously used for towing sleeves were very slow. It does, on the other hand, seem a pity that a type which would make such an

excellent dive bomber should not get a chance to perform such duties—particularly when the devastating results of the much slower, and less efficient Junkers Ju 87 in Poland are taken into account.

The Henley bears a fairly close family resemblance to the Hurricane and, in fact, the outer wing panels of both machines are interchangeable—the different centre sections making the necessary variations in wing area to accommodate the different loads. The construction of the Henley is of a curiously mixed and very practical type: the fuselage "core" is the well-tried Hawker tubular girder; the streamlined shape of the fuselage is obtained by wood-framed fabric-covered panels and fairings; the outer wing panels and tail plane are of stressed-skin light-alloy construction; the centre section has light-metal panels, but is not skin-stressed; the fin and all control surfaces are of aluminium-alloy construction covered with fabric. This may, at first, sound complicated and unwieldy, but it will be seen from the description that the designer has, in each case, chosen the structure most suitable for each job.

### The Main Plane Structure

In appearance the Henley is a mid-wing monoplane with the main plane set rather low, but structurally it is a low-wing monoplane. This paradox is explained by the belly beneath the centre section being no more than a bomb compartment with its attendant fairings. The wing is made in three pieces; a centre section and two outer panels. The centre section has two spars composed of heavy-gauge light-alloy webs, with large lightening holes, riveted to the polygonal tubular booms. The transverse bracing is made up from tubular girders and the aerofoil section maintained by

### Hawker Henley—Rolls Royce Merlin II

Span .. .. .	47 ft. 10½ in.
Length .. .. .	36 ft. 5 in.
Wing area .. .. .	342 sq. ft.
Take-off power .. .	880 h.p. at 3,000 r.p.m.
Max. climbing power (12,250 ft.) .. .	990 h.p. at 2,600 r.p.m.
Max. power (16,250 ft.) .. .	1,030 h.p. at 3,000 r.p.m.
Cruising power, 67% (15,000 ft.) .. .	690 h.p. at 2,600 r.p.m.
*Weight empty .. .. .	6,010 lb.
*Weight loaded .. .. .	8,480 lb.
*Max. Speed (17,000 ft.) .. .	272 m.p.h.
*Cruising speed (15,000 ft.) .. .	235 m.p.h.
*Stalling speed (sea level) .. .	65 m.p.h.
*Climb to 20,000 ft. .. .	19.4 min.
*Service ceiling .. .. .	27,000 ft.
*Range at cruising speed .. .	950 miles.
*These figures refer to the target-tower. The bomber is faster; a speed of 300 m.p.h. at 17,500 ft. being claimed.	

comparatively light former-ribs. The centre section is covered with various panels and fairings. The four petrol tanks containing a total of 205 gallons, are carried in the centre section (two in the leading edge and two between the spars) on each side of the fuselage.

#### Wings and Ailerons

The legs of the under-carriage are also completely housed in the centre section when retracted. The outer panels of the wing are of stressed-skin construction. The two centre-section spars are picked up and their line continued by two main spars with dual blanked duralumin webs riveted to extruded I- and T-section flanges. Between these main spars there are two light auxiliary spars with single webs and T-section flanges. The fore-and-aft bracing and the wing section are both provided by light-alloy flanged-blank ribs, or diaphragms. Between the spars "top-hat" sectioned lateral skin stiffeners position the profiles of the ribs and to these, to the spar booms and to the rib flanges the stress-bearing light-alloy skin is riveted. The fabric-covered metal ailerons are of the Frise-balanced type. The all-metal split flaps extend from the inner ends of the ailerons to the sides of the fuselage. Landing lights are let into the leading edges of the outer main-plane sections and navigation lights into the wing tips.

#### The Structure of the Fuselage

The stress-bearing structure is the well-tried Hawker tubular type which proved so successful in the Fury and Hart. It consists of four tubular longerons with side-bracing struts in the form of Warren girders. In plan there are plain cross-struts with wire diagonal bracing. Both the longerons and the short cross- and side-struts are made from round tubing, which is rolled to a square section at the joints so that the various tubes can be bolted together with flat gusset plates. The cross section of the finished fuselage is roughly oval throughout its length. This is obtained by fitting wooden decking and side formers with light wooden stringers and fabric covering. The forward part of the fuselage, as far aft as the pilot's cockpit, has the usual detachable aluminium cowling panels. The cockpit enclosure is of good aerodynamic shape, but is rather less glazed than is usual owing to the rear part forming an ingenious cowling for the protection of the gunner.

#### "Crash Pylon"

There is also a steel tube "crash pylon" between the pilot and gunner. It will be seen from the sketch at the beginning of the article that there are two slightly different cockpit covers. The first is that used on the original bomber and on one target-towing version, in which the target and cable are dropped after use; the other has two windows removed in order to allow room for a long casting which carries a windmill for the re-winding of the target cable.

The engine fitted to the Henley is the liquid-cooled Rolls Royce Merlin II. The arrangement of the radiator is somewhat unusual, though it will be recalled that the prototype Miles Master and production Merlin-Whirleys have similar installations. The radiator is ducted and incorporates the oil cooler and carburettor air-intake within the one cowling. The forward position, close to the airscrew, is the best for cooling and there is, theoretically at least, sufficient propulsive effect from the heated air expelled at the rear to offset the drag of the cowling. A three-bladed controllable-pitch airscrew is fitted. The ejector exhausts

(incidentally, this is a refinement originated by British designers) also provide a considerable thrust at maximum speed, easily overcoming their own parasite drag.

#### The Undercarriage

The undercarriage is of a straightforward type with oleo-pneumatic legs and medium-pressure types. Each unit is retracted hydraulically inwards, and slightly backwards, into the centre section. The tail wheel is also retractable.

The structure of the tail unit is mixed: the tail plane is a stressed-skin unit of light metal, similar in construction to the main-plane sections; the fin is fabric-covered, with a metal framework and leading edge; the rudder and elevators are similar to the ailerons.

#### Equipment

It will be seen that this mixture of methods of construction is by no means haphazard. The main and tail planes carry the heaviest air loads, therefore the structure has a stressed-skin metal covering. The centre section of the main plane houses many items of equipment and requires reinforcing for walkways, so the structure is of the old "spar-and-rib" type with easily detachable covering panels. The fuselage must be very strong, but does not have severe air loads; so that the strength

can be supplied by tubes and the covering by fabric—this is cheap, requires less highly skilled labour, keeps the wood and fabric shops employed and simplifies the installation of equipment. The fabric-covered controls are more general practice, because they have to be light to make mass balancing easy.

#### Colouring

In the peaceful days of last spring and summer, when the Henleys were coming into service, they were painted bright yellow with red, white and blue cockades on the planes and on the sides of the fuselage. A black machine number was painted on fuselage, rudder and under the main planes—tops of letters to the leading edge on the starboard, and to the trailing edge on the port sides. The airscrew blades were black and the spinner was polished aluminium. The walkways on the centre section were black. Although, at the time of writing, no details of the war paint of the Henley have been released; it may be presumed that the top half of the fuselage, the top surfaces of wing and of the tail plane and the fin and rudder would be shadow-shaded in dark green and chocolate brown. The cockades on top of the wing are probably red and blue only, those underneath and on the sides of the fuselage retaining the familiar red, white and blue.

## SIDE, PLAN AND FRONT VIEW OF THE HAWKER HENLEY

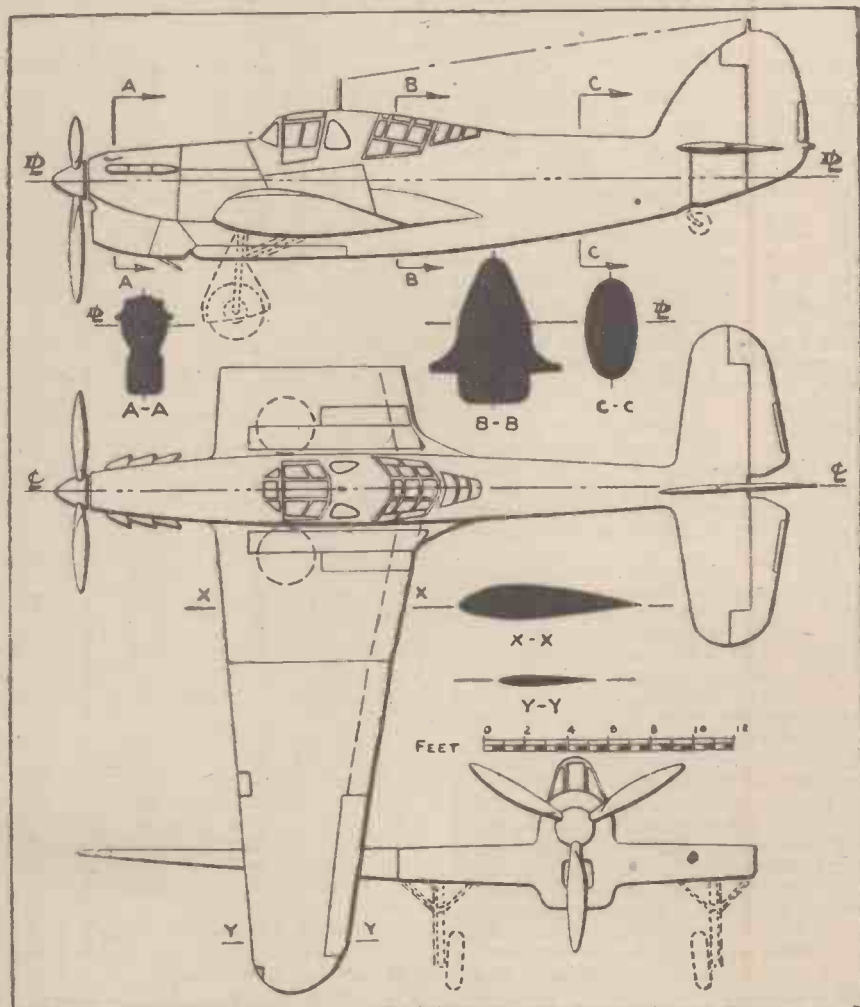

# Pebble Polishing

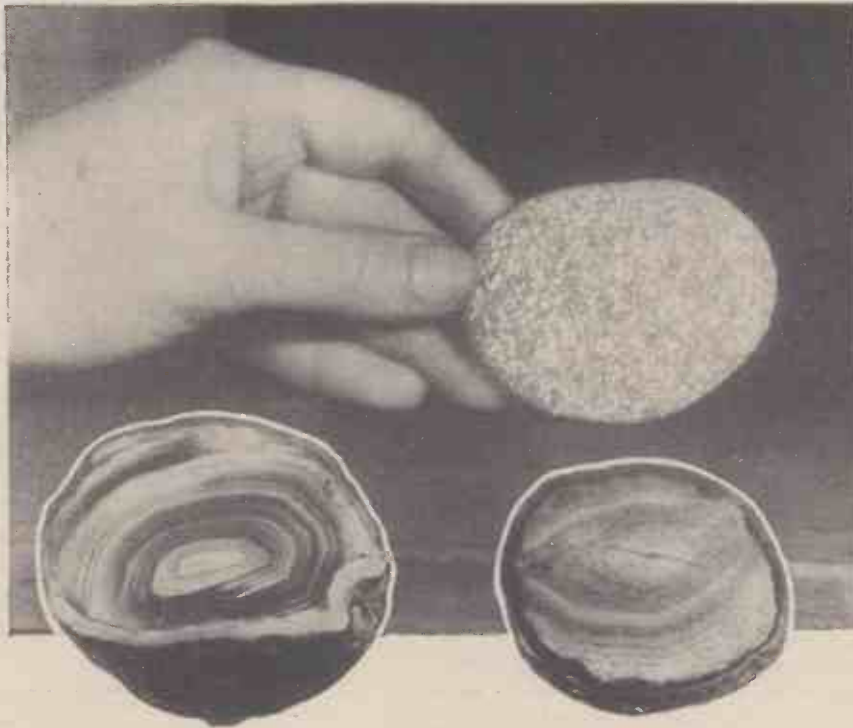

(Above) A lump of common lead ore which has been roughly ground and which now presents a highly attractive glistening appearance. (Inset) The beauty of the agate is revealed when such pebbles are cut into two halves, and the cut faces ground and polished

**T**HE beautiful art of the lapidary, or the cutting and polishing of minerals and semi-precious stones, is one which is not very widely practised nowadays. Yet ornamental and smoothly-polished minerals and stones have ever a peculiar and a characteristic charm, and there are few localities in which such objects, provided they are attractively produced, cannot be disposed of at a profitable rate.

Apart, of course, from the purely commercial side of the art of ornamental stone polishing, there is a strong scientific interest attached to it which will make its appeal to many readers of this journal. The art of stone polishing is by no means a difficult one.

Given reasonable patience and determination, however, any scientific and mechanically-minded reader can turn out, after a little preliminary practice, admirable specimens of polished minerals, particularly of the softer stones. The apparatus required is simple in the extreme. All that is necessary to embark upon the art of pebble polishing are a few grinding and burnishing materials, a hard saw of one description or another, some strong files, a hammer, a cold chisel or two and a few other odds and ends which are usually to be found in or about the average home workshop. If, of course, one can make use of any ordinary grindstone, so much the easier (in some cases) will the rough grinding of the stone be. And as one progresses in the art of stone and pebble polishing and becomes an expert lapidary, it will be advisable to rig up a rough sort of foot or power-operated

high-speed lathe, similar to the one sketched out in the diagram accompanying this article, such a lathe being preferably equipped with interchangeable cutting, grinding and polishing wheels, as will be described later on in these columns.

## Suitable Stones

The actual stones or minerals which are available for lapidary work are, of course, plentiful enough and obtainable everywhere. On the seashore, along the banks of rivers, in the country hedgerows, in fields, lanes, earthworks, sandy banks, and even in one's



Interchangeable polishing wheels for pebble burnishing. These comprise wooden discs about 4 in. diam. and 1½ in. thick. Glued (not nailed) to the edges are: A, leather on which is subsequently glued emery grains. B, soft or chamois leather. C, silk pad or similar material

own house garden or path "finds" of prettily-marked pebbles and stones are of common occurrence, whilst, naturally, almost any common pebble or lump of rock, pro-

## How to Cut, Grind and Polish Minerals and Semi-Precious Stones

vided that it is not too hard, will form quite suitable material for purely practice work.

Having found and selected the stone or lump of rock or mineral for polishing, the first thing to do is to determine the side or face of the object which is to be polished. Sometimes, as, for example, in the case of rounded pebbles, it will be impossible to do this, and in such instances, it will be necessary to cut the rock, pebble or stone in half, or, at any rate, to obtain an approximately straight surface from it.

In some instances, this may be effected by taking advantage of the property of cleavage possessed by some minerals whereby the stone will fracture cleanly along one definite plane when sharply tapped with a hammer or with a hammer and cold chisel.

In other instances, however, the stone or pebble will not respond satisfactorily to this treatment. Here, therefore, we are faced with the necessity of either cutting, sawing or grinding a flat surface on the stone.

Grinding can be effected by rubbing the stone first with a heavy file, and then by rubbing it continually on a flat piece of rough stone, one of the best varieties of which for this purpose is "Yorkshire Grit," which can usually be had from any tombstone cutter or monumental mason. It is essential during the grinding process that the whole operation be performed with the aid of plenty of water to act as a lubricant. The stones should never be allowed to become dry, otherwise a reasonably flat surface will not be attainable without undue energy, expenditure and difficulty.

Sometimes a round stone can be placed in a vice and sawn across with a very fine hacksaw, again using water (and plenty of it) as an essential lubricant.

## Cutting Stones

Workers who are able to construct a lathe similar to the one previously mentioned may often satisfactorily cut hard stones by setting up either a finely-toothed circular saw, or, better still, a plain steel disc having a sharpened edge. Carborundum wheels or "saws" are, of course, now articles of commerce, and if one of these is mounted on the spindle of such a lathe as the one above described, it will be capable of cutting neatly through the toughest of stones. In all cases, however, both the cutting implement and the stone, rock or other mineral under treatment must be lubricated continuously with water.

Having roughly ground, sawn or cut the stone or pebble to a flat face, the polishing of the latter should now be commenced. If the "polishing" face of the stone is still very irregular, it may be filed down, but, generally speaking, the use of a file at this stage should be avoided since such an implement tends to make too deeply incised scratches.

The roughly "faced" stone, mineral or

pebble should now be rubbed, "face" downwards on a "bed" consisting of a perfectly smooth sheet of lead on which has been scattered coarse emery powder and water. Coarse carborundum powder may also be used for this purpose, and, in many instances, with quicker results. The latter powder, however, is more expensive and, for the softer minerals, is definitely unsuitable in the coarser grades, since it "eats" too deeply into the soft stone surface.

Upon the above "bed" the stone is rubbed continuously by hand and in *one-direction only*. A circular and/or a haphazard rubbing motion must be avoided. After a few minutes of rubbing of the stone in the one direction, proceed to rub the stone in a direction at right angles to that of the first rubbing. The rubbing of the stone, therefore, has two movements—"lengthwise" and "across."

Several "beds" of lead sheet, each having successively finer grades of wetted emery or carborundum powder should be provided, and by these means, the stone or pebble face will gradually be "worked" up to the state of a rough polish. This state sets in when no distinct scratches are visible upon the "worked" surface of the mineral or stone.

#### Remove All Scratches

When grinding the stone face down to a rough polish by the above method, do not stop grinding with the one grade of abrasive until all the scratches made by the preceding grade have been completely obliterated. And, of course, in all these grindings, the abrasive must be kept well wetted with water.

The setting up of the final polish upon the rough-polished stone or mineral is not very difficult. The quickest method of achieving this end is to cut out a four-inch disc from a thick piece of wood. The disc should be cut very truly and mounted on the spindle of [the lathe or lapidary's "wheel" which has been previously described. Around the edge of the wooden disc should be firmly glued a stout strip of leather, and on the surface of the strip should also be glued a coating of fine emery (or carborundum) powder. The emery disc, as we may call it, is then revolved at high speed in the lathe, and the rough-polished face of the stone is lightly pressed the while against it, the stone being frequently dipped into oil or turpentine in order to lubricate it at this stage, since water as a lubricant would soften the glue.

It is a good thing to make several of these abrasive wheels, each presenting a finer grade of abrasive and by means of which the face of the stone can be successively worked up to a finer polish.

If such wheels cannot be made, a flat glass sheet should be substituted for it, and the hand rubbing of the stone continued against a scattering of fine abrasive (plus water in this instance) placed on the glass.

#### Final Stage

The final stages of the polish should be placed on the stone face by rubbing it by hand against a sheet of glass over which some gentle abrasive, such as chromium oxide or the very finest carborundum (Grade FFF) has been laid, water being used as the lubricant. Or, in the case of wheel polishing, a wooden disc should be set up on the lathe, the edge of the disc having glued to it a rim of thick chamois leather charged with green chromium oxide or other similar gentle abrasive.

The very last stage of the polish is given to the stone face by means of jeweller's rouge, applied either wet or dry. After

this, a gentle rubbing with a perfectly dry, soft silk pad completes the process, which, in some of its stages, may have appeared to the beginner to be somewhat lengthy, tedious and patience-demanding. However, as the amateur lapidary beholds with the pride of achievement the finely polished and gleaming face of his mineral or selected pebble and discerns thereon the revealed beauty of its natural and ineradicable markings, the labour spent in the polishing process will be deemed well worth the result if only for the sake of the interest inherent in the task.

Needless to say, there are countless modifications of the above general method of stone cutting and polishing. Every lapidary has his own favourite abrasives and grades of abrasives. He has his own individual implements, such as short cleft sticks in which small stones may be securely held cemented in place with pitch or similar adhesive compounds, the pitch being dissolved away in turpentine or other oil at the end of the polishing process.

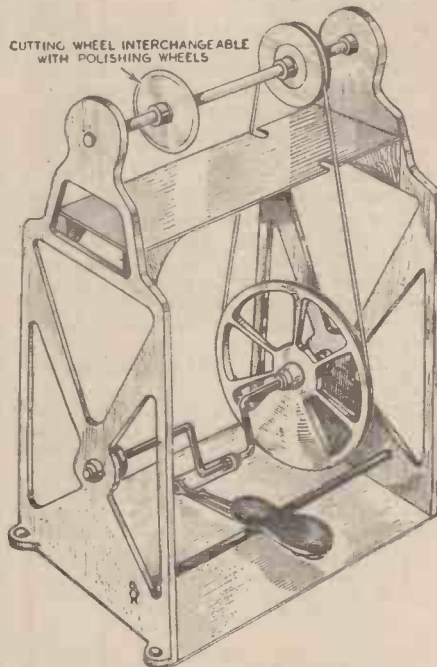

*Although not essential, a simple type of "wheel" or lathe built on these lines is conducive to much labour-saving in the cutting and polishing of pebbles and minerals*

In general, however, the essentials of the stone polishing operation, which is, after all, nothing more than a rubbing down with successively finer grades of abrasives, has been indicated above, and the instructions given will be sufficiently indicative to any interested amateur. Few books have been published on the subject, simply, perhaps, because few people have, in the past, been sufficiently interested in stone polishing. Yet, the task is one which can be full of interest when methodically undertaken, and, often enough, there are financial rewards to be gathered, particularly when, after practice, the worker can turn out highly-polished, strongly and peculiarly marked mineral objects for use as souvenirs, paper-weights, pendants, ornaments and the like.

#### Types of Stones

And now for a rapid review of the various types of stones, semi-precious and otherwise, which may be picked up by the searcher after such objects.

The seashore and the banks of rivers near their estuaries are, naturally, the most prolific in curious and quaintly-marked pebbles, particularly after a period of stormy seas, when strange mineral objects have been cast up by the tides.

In several parts of Britain, genuine amber may be so found. It is usually cast up upon the sea beach after stormy weather and it may take the form of rounded masses or flat fragments of the material. In either instance, however, great care must be taken in polishing native amber in order to develop its full yellow-brown hue, for the material is readily electrifiable by friction, and frequently, when in an electrically-charged condition, it will unexpectedly crack and even, at times, burst into pieces.

On the seashore pebbles consisting of black flint and hard white quartzite predominate. These are usually not worth selecting for polishing treatment, since they are exceedingly hard and possess no internal colours. But among these common pebbles may often be found pebbles of milky quartz banded here and there with golden and greenish veins. Agates, which are hard, many-coloured pebbles, which, when sawn up and polished, show remarkable internal ring formations, are sometimes to be found, as are, also, pebbles of chalcedony, and carnelian, a blood-red (or sometimes pinkish) variety of chalcedony. Frequently, these have been washed down from the coasts of Scotland, although some of them found on the east coast of Britain have been swept across from Norway.

#### From the Sea Shore

Then there are to be discovered on stony sea shores, after the tides have gone out, jaspers—red and dark green—varieties of onyx (greyish, white and brown-black), rose and orange-coloured quartz, and even (although these are much rarer) pale violet-coloured amethysts.

Nearly every curiously marked and banded sea-shore pebble is worthy of cutting and polishing, and the same, of course, applies to those similarly shaped pebbles which are found inland in rivers, on roads, in hedgerows and in fields and in a hundred and one other places and localities.

The hundreds of resplendent-hued minerals which are to be chipped out of rock veins in the mountainous regions of the British Isles are nearly all worthy of polishing treatment, particularly as such minerals may readily be obtained in flattish slabs of fairly large size.

The famous "Blue John" (fluorspar) of the Peak District is well known, as is, also, the olive-green Serpentine of Cornwall and other regions. Even common lead ores, which glisten like polished silver are worthy of at least, rough polishing, whilst the many varieties of copper ores (red, green and olive-hued) form equally interesting material for the lapidary.

In Surrey prettily-banded agates abound, although, of course, it takes a practised eye to recognise these from their rounded and pebble-like exteriors. Moss agates, which, when polished, give the appearance of clumps of greenish moss embedded in milky quartz, are not uncommon in many upland districts, but, unfortunately, like all agates, they are not easy to cut on account of their hardness.

Even the commonest granite, when given a lustrous surface by patient polishing, is a worthy material upon which to work. In large sizes, it may, after a little experience and practice, be cut up into teapot stands, book ends and other ornamental slabs, although, of course, a good deal of equipment is necessary in order to turn out such articles.



## QUERIES and ENQUIRIES

A stamped addressed envelope, three penny stamps, and the query coupon from the current issue, which appears on page iii of cover, must be enclosed with every letter containing a query. Every query and drawing which is sent must bear the name and address of the sender. Send your queries to the Editor, PRACTICAL MECHANICS, Geo. Newnes, Ltd., Tower House, Southampton Street, Strand, London, W.C.2.

### Cellulose Polish

PLEASE tell me the formula for making cellulose polish.—F. M. (Yorks).

YOU can make an effective polishing liquid for polishing cellulose work of all kinds by placing in a bottle the following ingredients: paraffin, 5 parts; linseed oil (raw),  $\frac{1}{2}$  part; methylated spirit, 3 parts. The parts can be calculated either by volume or by weight. Keep the mixture tightly corked and shake it well before using. Apply it to the cellulose work with a soft cloth, rubbing it well in and using it sparingly. You can, if you wish, omit the linseed oil in the above formula, but if you do the degree of polish obtained on the cellulose work will not last as long.

### Liquid Ink Eradicators

WHAT are the formulae for making liquid ink eradicator which act with the application of only one solution? Can you also give me any information as to the strength of the two-solution eradicator which consists of (a) calcium hypochloride, and (b) a dilute acid?—G. R. (Epsom).

ONE-SOLUTION ink eradicator are of varying compositions. Some comprise a strong solution of oxalic acid or of ammonium oxalate, while others combine one (or both) of the above substances with tartaric acid and/or ammonium tartrate. Others, again, are composed of a solution of sodium hypochlorite with or without admixture of sodium hydrosulphide.

Any of the above substances in strong solution will act as an eradicator of certain inks, but there is no such thing as a universal ink eradicator, it not being possible to remove carbon-containing inks without injuring the surface of the paper.

For the two-solution ink eradicator which you name, grind up a quantity of calcium hypochlorite with cold water. Filter the solution and then bottle it, using, for preference an amber-glass bottle. This is solution A. Solution B comprises a dilute solution (say 5 per cent. strength) of hydrochloric or sulphuric acid. When the two solutions are mixed, free chlorine is generated and this exerts a bleaching effect upon some inks, particularly those of the coloured variety.

### Silvering a Mirror

CAN you tell me the formula for silvering glass?—A. S. (Birmingham).

THERE are three general chemical methods of silvering glass. Of these the following, known as the Rochelle salt method, is the most readily worked for average purposes. Make up the following solutions:—

<b>Solution 1</b>		
Silver nitrate	0.5 gram.	
Rochelle salt	0.7 "	Boil and filter.
Water	250 ccs.	
<b>Solution 2.</b>		
Silver nitrate	2.5 grams.	
Water	25 ccs.	

To solution 2 add strong ammonia drop by drop until the precipitate formed just dissolves. After this, add one or two drops of weak silver nitrate solution until the liquid just becomes cloudy again. Then dilute the solution with 250 ccs. of water.

For use, the above two solutions (which should be freshly prepared) should be mixed in equal amounts and *instantly* poured over the surface of the glass. For this purpose, the latter should lie in a perfectly clean dish. Silvering will take place immediately and will be completed within about five minutes.

Before silvering, the glass should be very carefully cleaned preferably by rubbing it over with nitric acid. It should then be well rinsed. Just before silvering, it is advisable to immerse the glass in a strong solution of stannous chloride for a few minutes and, afterwards, to rinse the latter salt away.

Distilled water should be employed for making the solution.

The whole secret of successful silvering is (a) thorough cleanliness of all vessels and solutions, (b) cleanliness of the glass surface, and (c) accurate making up of the solutions. If you have not engaged in this work

previously, it would be advisable for you to perform a few experiments in glass silvering before embarking upon it for a serious purpose.

### Sound Waves

CAN sound waves be reflected, refracted and focussed? If so, can I focus sound with a glass lens and if not what can be used to focus it? Also, will a metal concave reflector reflect it?—F. P. (London, S.E.24).

SOUND waves can be reflected, but not focussed and refracted in the sense that light waves can be. Sound waves, of course, are actually waves in the air or in some other material substance, whereas light waves are much more subtle creations, being electromagnetic in nature.

You cannot focus sound with a glass lens, but you can, to a certain extent reflect it from a plane surface, as, for example, a sheet of rigid metal or other material held at an angle in the path of the sound waves. In this way, the waves can be reflected through a right angle. A concave metal reflector will also reflect sound and, in a peculiar sense, focus it by causing it to converge upon a given area.

### A Fog Filter

CAN you tell me how to make a respirator suitable for using when applying cellulose dope? Also, how can I make a simple filter for fitting over an open window to keep out smoke and fog laden air?—J. G. Leicester.

IT is not usually necessary to employ a respirator when working with cellulose paints and enamels, provided that the surroundings are adequately ventilated and, short of a "service" type of respirator, there is none which would hold back completely the solvent vapours. Such a respirator you would find impossible to construct on your own account in view of the metal, rubber and celluloid face-piece which is required.

To a very great extent, however, you will find it possible to suppress the fumes of cellulose dope, paints and enamels simply by tying several layers of a loose, absorbent cloth over your mouth and nostrils. The cloth should be thoroughly damped (but not actually sodden) with water. Cellulose solvent fumes cannot penetrate a barrier of this description. Hence if you can construct some type of wire frame to fit in front of the mouth and nose and place over it the moistened cloth we think you will obtain reasonable satisfaction from such a simple device.

Three or four layers of fine yet strong muslin stretched over an open window will make a serviceable smoke and fog filter. The muslin sheets must not all be touching. It is best if they are spaced at intervals of half an inch from each other. The muslin needs no damping or any other special treatment. It must, however, be free from holes and flaws and well secured at its edges.

### Thermite

WHAT is the composition of "Thermite" and what happens when it is ignited?—F. S. (Yorkshire).

"THERMITE" is a mixture of aluminium powder, iron oxide (or some similar oxide) and a flux, such as fluorspar. When suitably ignited, the mixture burns with great heat, attaining a temperature of nearly 3,500°C. The iron or other oxide is "reduced" to the metallic state, the aluminium abstracting the oxygen from it. "Thermite" mixtures are frequently used for welding purposes.

### THE P.M. LIST OF BLUEPRINTS

- F. J. CAMM'S PETROL-DRIVEN MODEL MONOPLANE**  
7s. 6d. per set of four sheets, full-size.  
The "PRACTICAL MECHANICS" £20 CAR  
(Designed by F. J. CAMM)  
10s. 6d. per set of four sheets.
- "PRACTICAL MECHANICS" MASTER BATTERY CLOCK  
Blueprint 1s.
- The "PRACTICAL MECHANICS" OUT-BOARD SPEEDBOAT  
7s. 6d. per set of three sheets.
- A MODEL AUTOGIRO**  
Full-size blueprint, 1s.
- SUPER-DURATION BIPLANE**  
Full-size blueprint, 1s.
- The P.M. "PETROL" MODEL MONOPLANE  
Complete set, 5s.
- The 1-c.c. TWO-STROKE PETROL ENGINE  
Complete set, 5s.
- STREAMLINED WAKEFIELD MONOPLANE—2s.**
- A LIGHTWEIGHT GLIDER**  
Full-size blueprint, 2s.
- MODEL DURATION MONOPLANE**  
Full-size blueprint, 2s.
- WAKEFIELD MODEL**  
Full-size blueprint, 2s.
- "FLYING" LOW-WING PETROL MODEL PLANE  
Full-size blueprint of wing sections, 6d.
- LIGHTWEIGHT DURATION MODEL**  
Full-size blueprint, 2s.
- P.M. TRAILER CARAVAN**  
Complete set, 10s. 6d.

The above blueprints are obtainable post free from Messrs. G. Newnes Ltd., Tower House, Strand, W.C.2



# AUTHORITATIVE TRAINING in Wartime

In peacetime The T.I.G.B. home-study courses provided first-class technical education. For several years past the pass percentage of T.I.G.B. Students at Professional Engineering Examinations such as A.M.Inst.C.E., A.M.I.Mech.E., A.M.I.E.E., A.F.R.Ae.S., C. and G., etc., has not once been lower than 96%—and no fewer than 22 FIRST PLACES have been gained. In Wartime the advantages of T.I.G.B. Training are most marked. To-day, The T.I.G.B. courses are the ideal method of qualifying quickly for the great range of posts being offered by Industry and the Government to technically trained engineers, the need for whom needs no over-stressing. Write TO-DAY for "The Engineer's Guide to Success," containing the world's widest choice of engineering courses covering all branches and recognised qualifications. Mention branch, post or qualification that interests you. The T.I.G.B. guarantees training until successful for the one fee.

The Technological Institute of Great Britain  
218 Temple Bar House  
London E.C.4

(Founded 1917)  
20,000 Successes



## RISE TO THE HEIGHT



**of Holiday Happiness**  
Why not be taller for the holidays with the aid of Challoner's Famous Formula  
**H.T.N. TABLETS**  
and safe easy system. No strenuous exercises or old-fashioned appliances. If one box is insufficient we guarantee to supply a further box FREE. A.L.(Wilts.) writes: "Since I started your Treatment I have gained 3 inches in height." Full particulars 1/4d. (part postage) Sample 9d. Book on height improvement 3d., stamps or P.O. only. Sent under plain sealed cover.

THE CHALLONER CO., Dept. C39,  
Laboratory & Works, Hyde Heath, Amersham, BUCKS.

HAVE YOUR OWN  
**CINEMATOGRAPH SHOW**  
AT HOME

The New "Homray" Projector  
Hand Turned Model for 60 & 300ft.  
**32/6**  
Mains Motor Driven Model (Universal)  
**£3.17.6**

Obtainable from leading Stores and Photographic Dealers Write-day for illustrated list and name of nearest stockist  
**HOMRAY PROJECTOR COMPANY**  
(Dept. P.M.), 46 High Pavement, Nottingham



"Working Model Railways." By E. F. Carter. Published by Percival Marshall and Co. 68 pages. Price 1s. 6d. net.

THE fascinating subject of model railways is dealt with in a general way in this useful handbook. It has rightly been said that "no other hobby offers such unlimited scope for individuality and ability," and for general amusement and educational value the hobby of model railways undoubtedly takes pride of place. In this book technicalities have been avoided and the subject has been dealt with in an attractive manner in order to introduce the reader to the pros and cons of the hobby. The meaning of gauge and scale, designing the layout, laying the track, locomotives and rolling stock, and methods of operation are amongst the subjects which are clearly explained with the aid of diagrams and photographic illustrations. This handbook should prove invaluable to all those thinking of taking up the hobby.

## ITEMS FROM THE TRADE

### Rawplug Company's Novel Calendar

THE Rawplug Co., Ltd., makers of the well-known fixing devices, have published a novel calendar for 1940. It shows, in the form of graphs, the hours of moonlight for every month of the year. The moonlight period of each month is shown graduated from blue to white and thus indicates the hours and dates of brightest moonlight at a glance. The hours of sunset and sunrise are given and are shown by means of orange-coloured strips across the top and bottom of each graph. Any reader who is interested in the products of this Company should send for a copy to, The Rawplug Company, Ltd., Rawplug House, Cromwell Road, London, S.W.7

### Floor Staining Made Easy

WHETHER you desire to treat the whole of a floor or merely to stain and varnish the surround, a beautiful effect can easily be obtained by the use of Varnene Oil Varnish stain. With Varnene, the stain sinks deeply into the wood, leaving on the surface a high-gloss varnish which will not readily chip or scratch and which brings out in exquisite detail the grain and "figure" of the wood. Varnene is obtainable in Dark Oak, Mahogany, Walnut, Light Oak and Ebony Black and with these colours perfectly natural wood effects can be obtained on ordinary floor boards. Furniture can also be renovated by using the appropriate shade. A notable feature of Varnene is its smooth, free flow which makes it easy to distribute the colour with the perfect evenness essential to a good result. Clear Varnene, which is colourless, can be used for any varnishing purpose. It is obtainable at most Ironmongers, Oilmen, Grocers and General Stores in 6d., 1s. and 1s. 6d. tins.

## TAKE UP PELMANISM

For  
Courage and Clear-Thinking

### The Grasshopper Mind

YOU know the man with a "Grasshopper Mind" as well as you know yourself. His mind nibbles at everything and masters nothing.

At home in the evening he tunes in the wireless—gets tired of it—then glances through a magazine—can't get interested. Finally, unable to concentrate on anything, he either goes to the pictures or falls asleep in his chair. At the office he always takes up the easiest thing first, puts it down when it gets hard, and starts something else. Jumps from one thing to another all the time.

There are thousands of these people with "Grasshopper Minds" in the world. In fact they are the very people who do the world's most tiresome tasks—and get but a pittance for their work. They do the world's clerical work, and the routine drudgery. Day after day, year after year—endlessly—they hang on to the jobs that are smallest-salaried, longest-houred, least interesting, and poorest-futured!

### What is Holding You Back?

If you have a "Grasshopper Mind" you know that this is true. And you know why it is true. Even the blazing sun can't burn a hole in a piece of tissue paper unless its rays are focussed and concentrated on one spot! A mind that balks at sticking to one thing for more than a few minutes surely cannot be depended upon to get you anywhere in your years of life!

Specialty reduced fees for serving members of His Majesty's Forces

The tragedy of it all is this: you know that you have within you the intelligence, the earnestness, and the ability that can take you right to the high place you want to reach in life! What is wrong? What is holding you back? Just one fact—one scientific fact. That is all. Because, as Science says, you are using only one-tenth of your real brain-power.

### What Can You Do About It?

That is the question you are asking yourself. Here is the answer.

Take up Pelmanism now! A course of Pelmanism brings out the mind's latent powers and develops them to the highest point of efficiency. It banishes such weaknesses and defects as Mind Wandering, Inferiority, and Indecision which interfere with the effective working powers of the mind and in their place develops strong, positive, vital qualities such as Optimism, Concentration, and Reliability, all qualities of the utmost value in any walk of life.

Over half a million satisfied people have taken the Pelman Course. To-day the sons and daughters of men and women who took the Pelman Course long ago are taking the revised Course.

A big and unique asset of the Pelman Institute is its large staff of trained Instructors and Examiners, long experienced and with sympathetic understanding.

The Pelman Institute is known the world over and has old-established and flourishing branches on each of the five continents.

The revised Course is fully explained in "The Science of Success." The Course is simple and interesting and takes up very little time. You can enrol on the most convenient terms. The book will be sent you, gratis and post free, on application to-day to:

### Pelman Institute

(Established over 40 years)

130 Pelman House, Bloomsbury St., London W.C.1

PELMAN (OVERSEAS) INSTITUTES: PARIS, 176 Boulevard Haussmann. NEW YORK, 271 North Avenue, New Rochelle. MELBOURNE, 396 Flinders Lane. DUBAN, Natal Bank Chambers (P.O. Box 1489). JOHANNESBURG, P.O. Box 4828. CALCUTTA, 102 Clive Street. DELHI, 10 Atipore Road. AMSTERDAM, Damrak 68. JAYA, Malabarweg, Malang.

# ELECTRADIX BARGAINS



"LESDEX" MERCURY REMOTE SWITCHES will operate almost indefinitely; hermetically sealed and absolutely gas tight. For Battery or Mains.

S.P. MERCURY GLASS TUBES, 5 amps., 5/-; THERMOMETERS, Panel 21 in. dial, 5/-; ether tube for distant indication, 10/6. FOURNIER THERMOMETERS by Cambridge Instrument Co., 4in. dial, 10-110 deg. Cent. Fitted adjustable electric contacts, 45/-; 12in. right angle Immersion Thermometers to 150 Cent., 3/6.

SWITCH-GEAR CIRCUIT BREAKERS, single-pole, open type breakers, 50 amps., adjustable trip, each 27/6. Single-pole open type 200 amps. time lag 5 to 20 secs., 60/-; S.P. small Circuit-breakers, totally enclosed, up to 4 amps., 6/8, with thermal delay trip, 10/-; 10 amps., 14/-; 20 amps., 18/6. Also in D.P. and triple, 100 amp., 60 v., 2 A.P. Ironclad Switch, 20/-.

CONTACTORS, S.P., 5 to 15 amps. A.C. and D.C., 100 v., 220 v., 250 v., 17/6. Mercury Switches, 230 volt, D.P., 22/-; 15 amps., S.P., 20/-; D.P., 25/-; With time lag of 30 secs., 15 amps., 220 volts, 35/-; Two Starter 20 amps., S.P. Ironclad, 220 volts, D.C. coil, 25/-; Three 4-pole or twin D.P. open type Contactors on bakelite panel, 25 amps., 220 v. D.C. coils, 27/6; Triple ditto and two on, one off, 25/-; Battery charge autos, 15 amps., 10/6; X-Ray Time ex-Switch, 1 to 15 secs. trip, hand type, 40/-.

A.R.P. PETROL ELECTRIC GENERATING SETS for Lighting and Charging, STUART TURNER DIRECT COUPLED SETS, 150 watts D.C., 1,300 r.p.m. 2-stroke water-cooled 1 h.p. 1 cyl. Engine with fuel and oil tank, magneto ignition. On bed plate with 30 volts 5 amps. Dynamo, £12 10/-.

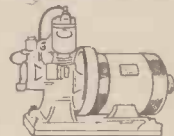

Large size kW S.T. Petrol Electric Sets, 500 watts, 2-stroke water-cooled 1 h.p. 1 cyl. Engine on bed plate direct coupled to 50/70 volts 10 amps. D.C. Dynamo magneto ignition, fuel and oil tank, £17 10s. worth double.

Horizontal Twin Petrol A.B.C. Engine fan-cooled, coupled 11 kW. D.C. Dynamo 50/70 volts 25 amps., Mag. Ignition, sale £25.

21 kW AUSTIN, 2 cyl. water-cooled Engine, Mag. Ignition and 110 volts 25 amps. Dynamo, £28. Austin 3½ kW., 110 volts, £48. Switchboards, £5. Stamp for Special Leaflets.

A.R.P. EDISON HIGH CAPACITY ZINC CELLS for standby lighting, 120 A.H. to 300 A.H. at HALF PRICE 20/- to 25/-. Makers' Prices from £5. Stamp for leaflet.

Medical Shock Cells, 4/- and 6/-.

Small Spark Ignition Coils 6 or 12 volts, 3/6. With vibrator, 4/6.

250 NEON LAMPS. Standard size letter neon bulb with holder 220/240 v., 2/6.

WIRE. Special Clearance Bargain. 45 gauge Eureka 10 m.a. enamelled, 108 ohms per yd., 3/- per lb. 36 gauge Eureka 100 m.a., 1/- per lb. 33 gauge Eureka 250 m.a., 1/- per lb. 29 gauge Eureka, 1/- per lb. 27 gauge Eureka 500 m.a., 10d. per lb.

BARE Resistance Wire, 48 gauge nichrome, 700 ohms per yd., 6/- per oz. Heating Strip, chrome, 1/32 x 16 thou., 2/6 per lb.

TELESCOPES. Navy Telescopes, gun type spotters, 25/-; MAGNETIC Bin. COME ASH with Plain Scale, Bevel glass, brass body. A British Bargain for 6d. only

MOVING-COIL MIKES. P.M. moving-coil mike, model T.M., Echo type, needs no battery, directional correct frequency response, ideal for P.O. A.M. and recording, 55/-; Table stand, 7/6. Transf. 7/6.

FLOOR STANDS, 26in., 12/9; 37in., 15/-; 49in., 18/6.

SELF-EXCITING ALTERNATORS, H.F., 500 cycles, 20 amps., 10 volts, £3 10s. Ditto, double, type W, 500 cycles, 100 volts, 3 amps., and 70 volts, 3 amps. D.C., £5 10s.

MEGERS. 100 volts, 250 volts and Bridge Meggers.

WHEATSTONE BRIDGES, etc. Slider type, 37/6. Pocket Bridge, £6. Plug types, portable, G.P.O., £7 10s. Silver-town, £8. Paul type, 4-dial, cheap. Universal Shunts, 15/-; Reversing Keys, etc., cheap.

METER MOVEMENTS. Full size, moving coil, P.M., for adapting home-made multi-range testers. For 3in. or 4in. dials, 5/-, post 1/-.

G.P.O. TYPE B TELEGRAPH RELAYS, with platinum points, 7/6. Silvertown Horizontal Galvos., two jewels, 5/-, post 6d. Vertical needle G.P.O. Teleg. Galvos., 4/6. Weston 2in. dial centre-zero ammeters, read 1 amp. to 15 amps., 5/-.

TAPE MORSE RECORDERS. For radio to 30 w.p.m. or land line. Portable without case, very complete model with key and meter indicator, £8 10s. Standard G.P.O. type with tape reel on base, £6 10s. For experimenters we have a few incomplete with perfect spring drive, 35/-; Paper tape reels, 6d.

BUZZERS, small type, with cover, 1/6. Power Buzzers, with screw contact and adjustable spring armature, 2/6. Heavy Buzzers in Bakelite case, 3/6.

6/- EMERGENCY PARCELS of useful stand-by electrical and radio repair material and apparatus, 10 lbs. for 6/-. Post free.

20 PAGE SALE LIST STILL FREE ON REQUEST BUT Stamps must be sent for List or with all letters wanting answer.

MOTORS. Low-priced Dynamos, Motors and Motor-driven appliances for D.C. and A.C. 50 cycle supply.

**ELECTRADIX RADIOS**  
218 Upper Thames Street, London E.C.4  
Telephone: Central 4611

# GALPINS

ELECTRICAL STORES  
75 LEE HIGH ROAD, LEWISHAM  
LONDON, S.E.13

Telephone: LEE GREEN 5240  
Terms: Cash with Order

P.M. PUBLIC ADDRESS MOVING COIL SPEAKERS, Large Horn size, 40 in. x 30 in. Flare. Price 75 each. 5/- extra for packing. C/F.

A.C. INDUCTION MOTORS, 200/240 volts, 50 cy., 1 ph., approx. 1 h.p., 1,425 r.p.m., ball-bearing, in new condition, 27/6 each, post 1/-.

X-RAY TUBES, 4 to 7-in. bulbs, tungsten targets, 15/- each; platinum targets, 25/- each. 2/6 extra for packing. C/F.

PHILIPS PRE-STAGE AMPLIFIERS. Consisting of 4 x 4 mt. 750 volt condenser, 400-volt transformer, L.F. choke. Less valves, 10/- each. C/F

WESTON MOVING-COIL MILLIAMM METER-50 to 50 mA., 1-in. dial-model (506), as new, 20/- each. Ditto, 301 model, 0 to 3 mA., 30/-; 0 to 50 mA., 25/-.

VOLTAGE CHANGING TRANSFORMERS, 100/110 to 200/240 volts or vice-versa auto wound. All fully guaranteed. 250 watts, 25/-; 500 watts, 32/6; 1,000 watts, 50/-; 1,500 watts, 62/6; 2,000 watts, 75/-; Delivery guaranteed 7 days from date of order.

STUART TURNER 21 H.P. PORTABLE ENGINE Petrol, twin flat air-cooled complete with all accessories, in good condition. £7 10s., C/F.

DYNAMOS, for charging or lighting, etc., all shunt wound and fully guaranteed. 100-volt 10 amp., 4-pole, 1,500 r.p.m., 90/-; 50/75-volt 15 amp., 1,750 r.p.m., 4-pole, 90/-; 30-volt 10 amp., ball bearings, 1,500 r.p.m., 4-pole, 70/-; 25-volt 8 amp., 1,750 r.p.m., 2-pole, ball-bearing, 37/6; 50/75-volt, 25 amp., 4-pole, 1,500 r.p.m., 110/-.

ELECTRIC LIGHT CHECK METERS, for sub-lettings, garages, etc. 200/250 volts, 50 cy. 1-ph., supply 5, 10 or 20 amps., 6/- each, post 1/-.

TRUVON PUBLIC ADDRESS HORN SPEAKER, UNITS, 15-ohm. speech coil, 6-volt field, 15/- each, post 1/6.

HIGH VOLTAGE TRANSFORMERS for television, neon, etc., 200/240 v. 50 cy. 1-ph. primary 5,000 and 7,000 volts secondary, enclosed in petroleum jelly. Size: 5½ in. x 4½ in. x 4½ in., 7/6 each, post 1/-; Ditto, skeleton type, 5/6, post 9d. All brand new.

PORTABLE LIGHTING ENGINES, 21-twin Douglas, special, air cooling, complete with all fittings, including petrol tanks, etc., fully protected, condition as new, £10. C/F.

SILVERTOWN HORIZONTAL GALVANOMETERS jewelled movements, 5/- each, post 6d.

MULTI-CONTACT RELAYS, EX-G.P.O., as used in automatic exchange, condition as new, small size, suitable for automatic tuning for press-button control heavy platinum contacts, 2/6, post 3d.; 2 for 4/-, post 6d. 2 for 4/-, post 6d.

# BECOME A DRAUGHTSMAN

AND EARN BIG MONEY



Men over 21 urgently wanted for reserved occupations as draughtsmen in Electrical, Mechanical, Aeronautical, Structural, and other Branches of Engineering. Excellent opportunities also for men and women of all ages to become Inspectors, Viewers and Gaugers. Practical experience is unnecessary for those who are willing to learn—our Guaranteed "Home Study" courses will get you in.

**FREE GUIDE.**—The FREE 1940 Guide contains 120 pages of information of the greatest importance to those seeking entry or advancement in Engineering. It gives full details of salaries, openings and prospects in Draughtsmanship, together with particulars of our special rapid courses and employment service and remarkable guarantee of

**SUCCESS—OR NO FEE**

Write now for your copy of this remarkable publication. It may well prove to be the turning point in your career.

**NATIONAL INSTITUTE OF ENGINEERING**  
(Dept. 420) 148, HOLBORN, LONDON, E.C.1.  
(S. Africa Branch: E.C.S.A.,  
P.O. Box 8417, Jo'burg)

# TOOLS

GRAYSON'S Glass-boring Outfits and Tube Cutters avoid risk.—Below.

DRILLS, Taps, Dies, Files, Chisels and Punches. Best quality at keenest prices.—Grayson & Company, 300 Camp Lane, Sheffield.

BRAND NEW POWER TOOLS of quality. 10-inch bandsaws, 54s.; Jigsaws, 22s. 6d.; Bench Drills, 11s.; Circular Saws from 25s.; 3-inch S.C. Toolroom Lathes, from £4 5s. New 1-inch chromium-plated Micrometers, 12s. 6d.; Electric Drills, 37s. 6d.; Grinders.—John P. Steel, Bingley.

MYFORD LATHES have no equal, real Precision job. List free, delivery anywhere. Terms still available. Your lathe taken in part exchange.—Nuttall's, 20, Albert Street, Mansfield.

AN APOLOGY! J. Burke regrets the delay in delivery of orders during March, this being due to circumstances over which we have no control, business having been suspended for nearly three weeks. We would assure our numerous clients that delivery of the following items will be given same day as order received. All previous Adverts are now cancelled as we are unable to obtain further supplies of some lines.

- 3/6 any Lot. Six lots 11.
- 8" Sq. Toolholder with Four H.S. Tools.
- Eight assorted H.S. Tools for above.
- Adjustable Boring Tool with H.S. Cutter.
- 1/8" to 1/4" Silver Steel 13 pieces 13" Long Precision ground to size.
- 1/2" to 3/4" Silver Steel 4 lbs. 2" to 4" long.
- 1/8" to 7/32" Super High Speed Steel, Precision ground, 6 ft. ass. 2" to 3" long.
- Five Slitting Saws, 3/2" to 3/8" thick, 2 1/2" Diam. 5/8" hole.
- Five 1" Round Dies. 1/4"; 3/8"; 1/2"; 5/8"; 3/4"; Whit. or B.S.F. only.
- 500 ass. Brass and Steel Plated Screws, etc.; B.A. and Fine threads. 3/2" to 1/2".
- 100 Bright Hex. Bolts with Nuts, 1/8" to 1/2" Diam. 1/2" to 3" long. Surprising Value.
- 12 Ass. Fine Thread Taps 1/2" to 1" Diam.
- Three Doz. Tungsten Hack-saw Blades, any size 9"; 10"; 12".
- 18 Grinding Wheels. 1/2" to 1" Diam. suitable for Flexible Shaft use.
- Three H.S. Tap or Reamer Fluting Cutters, 1 1/2" Diam. 3/4" Hole. Worth 6/- each.
- 18 ass. Files 4" to 6". Handy variety.
- 12 ass. Files 4" to 12".
- 12 ass. Toolmakers Needle Files. Indispensable.
- 12 ass. Carborundum and Fine Emery Wheels. 1/4" to 3/4" Thick, 2" to 4" Diam. all 1/2" Hole.
- 3 1/2 lbs. Best Blue Twill Emery Cloth Strips. 1/2" to 2" wide; ass. Superfine to Coarse.
- SPECIAL OFFER.—1" All Steel Die-Stocks; 2/6. 1/4" to 1" Adjustable Tap Wrenches, 2/6. Three Doz. Large Files, 12" 16" Ass. Shapes, etc. £1 carr. for.
- £1 orders Car. Paid except abroad.
- J. BURKE, 30, TRIPPET LANE, SHEFFIELD, 1.

# MAKE & MEND with SAMSONITE

The Transparent . . . Heatproof . . . Quick-drying Adhesive Lacer. Ideal for all hobbies and model-making. Instantly joins—

- Wood.
- Ebonite.
- Mica.
- Glass, etc.

Samsonite is also the perfect medium for repairs to household glass, china, leather, fittings—the list is endless. Simple to use. Send 1/- now for a large tube, post free (3 tubes for 2/6).

LAMBART & SMYTH, Ltd. (Dept. P.M.)  
16 VICTORIA STREET, LONDON, S.W.1.

**BE TALLER** CLIENTS GAIN 1 to 6 ins.  
Increased my own Height to 6ft. 3 1/2 ins.  
No Appliances—No Drugs—No Dieting  
ROSS SYSTEM NEVER FAILS  
Fee £2.2s. Complete. Details 6d. stamp:  
MALCOLM ROSS, BM/BYTE, LONDON, W.C.1





All letters should be addressed to the Editor, "THE CYCLIST," George Newnes, Ltd., Tower House, Southampton Street, Strand, London, W.C.2.

Phone: Temple Bar 4363.

Telegrams: Newnes, Rand, London.

VOL. IX.

JUNE, 1940

No. 220

## Comments of the Month

By F. J. C.

AS announced in the last weekly issue of *The Cyclist* it has been found necessary owing to the paper shortage occasioned by the invasion of Norway, to suspend separate publication, but to preserve the continuity of publication by the inclusion of a supplement in PRACTICAL MECHANICS which will include some of the more important features.

Readers of *The Cyclist* are reminded that the staff of that journal are still available to answer technical queries, plan tours, and to continue the service which formed such an important feature of the journal. Great efforts are being made to find a solution to the paper problem, and readers may rest assured that when adequate supplies become available, separate publication will be resumed. When we reappear, as we undoubtedly shall, announcements will appear in the national newspapers, and a sum of money has been set aside for that purpose.

In the somewhat restricted space of the new platform from which we address readers of *The Cyclist*, we shall continue to act as their advocate, and to watch their interests, as well as to criticise and to comment. The supplement may be separated from the paper and bound up in the usual way.

### The Export of Bicycles

THE British Cycle and Motor Cycle Manufacturers were recently invited by the Export Council appointed by the Board of Trade to organise war export groups and at a general meeting of manufacturers two groups were formed to represent the bicycle and motor cycle industries respectively. In view of the shortage of certain classes of material, and the insistence of the war cabinet upon a programme of work to increase the total volume of British exports by £200,000,000, these groups will have an important effect upon the development of the cycle industry during the war. Materials may not be available except to firms who are prepared to co-operate in the objects and work of the export groups. It is expected eventually to export 75 per-

cent. of the material allotted to the bicycle and motor cycle industry, and for the home trade the only supplies available will be the balance of the unexported material. In 1938 the total value of exports of the industry was £4,383,824. Although we have lost the Scandinavian markets, the U.S.A. is now evincing interest in British bicycles, and it is possible that in the near future there will be considerable increase in the export of British bicycles to that country.

### Mr. H. N. Crowe

MR. H. N. CROWE has taken up a commission in the Pay Corps and has been granted leave of absence from his duties at the N.C.U. in consequence. Mr. Crowe, jun., is already in the army. Mr. H. N. Crowe has been secretary of the N.C.U. for just over 21 years, and during the last war he was a major in the Machine Gun Corps. He has performed valuable work for the N.C.U. since he joined it in 1919, when its prestige and its membership were low. In 21 years the membership has steadily increased. One of the innovations for which he was chiefly responsible was the third-party insurance and free legal advice which forms part of the benefits of N.C.U. membership.

### Godwin's Ride

TOMMY GODWIN, on May 1st, demonstrated that his colossal mileage piled up since January 1st, 1939, since when he has averaged over 200 miles each day, has not affected his staying power. After riding nearly 98,000 miles a speed ride was arranged by Charlie Davey from Winchester Cathedral, through Alresford, Alton, Farnham, Chilworth, Dorking, Reigate, Redhill, Nutfield, Godstone, Westersham, Riverhead, Wrotham Heath, Aylesford, Charing to Canterbury Cathedral, a total of 120 miles, which he covered in 6 hrs. 8 mins. 43 secs. The course was not an easy one, and he suffered two punctures, and a delay at a level crossing which lost him a total of nearly 7 mins. He finished his 100,000

miles in 500 days at the Paddington Track on Whit Monday. He used the 4-speed hub gear which has been of so much assistance to him on his ride. He actually finished his 100,000 miles in 499 days.

### The Centenary Club Tour

THE second spring tour of the Centenary Club was carried out last month over a course of nearly 90 miles which took them through the delightful scenery of Shropshire. The members of the Centenary Club are, of course, chiefly bicycle manufacturers and their executives. Frank Urry has again been elected president. Major F. W. Smith was elected vice-president and president elect for 1941, and Mr. H. R. Horden was appointed as secretary in place of Major H. R. Watling. Mr. F. C. Parkes was re-elected as hon. treasurer.

### The London Centre Meeting

THERE was a somewhat stormy atmosphere at the adjourned A.G.M. of the N.C.U. London Centre. It is significant that Press men were not invited, but accounts which reach me show that the members were by no means satisfied with the manner in which the centre has been run. There were criticisms of the manner in which the accounts had been kept, complaints of inaccurate certificates, lack of attention to correspondence, lost books, and so on. It ended with the resignation of the secretary, John Penn, and the assistant secretary, L. J. Gladman. There was much acrimony.

### London Bicycle Polo League

THE recently formed Red Cross Bicycle Polo League is comprised by the Four Aces B.P.C., the Poly Vue B.P.C., the Wren Wheelers C.C., The Pyramid C.C., The Tooting B.C., The Norwood Paragon C.C., The Addiscombe C.C., and The Old Portlians C.C. Meetings will be held Monday, Tuesday, Wednesday and Thursday evenings at the Addiscombe Recreation Ground. Matches start at 7.45 p.m.

### Queries

WILL readers please note that it is essential to enclose a stamped addressed envelope when a postal reply is desired? Where such are not sent, the replies will appear in this journal.

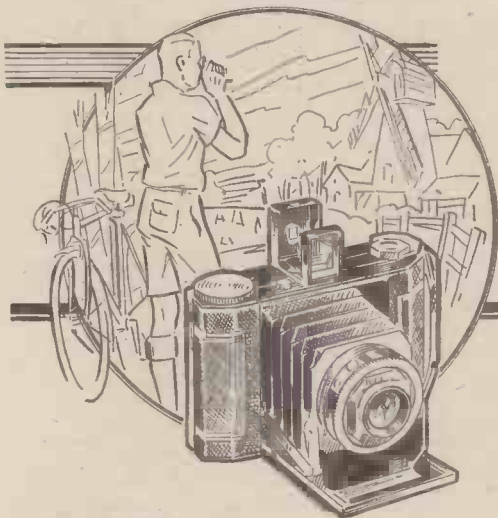

### Friendly Enemies

**VOPEL**, the German, and **Audy**, the Frenchman, were partners in the recent **Pittsburg Six Days' Race**. The event was won by **Walthour** and **Thomas**.

### More Women Cyclists

**ACCORDING** to **Mr. J. W. Bryan**, director of the **B.S.A. Company**, women are causing a minor boom in the cycle industry. In their case they account for 48 per-cent. of the sales. Usually women represent about 22 per-cent. of the bicycle buyers. The purchasers are not all young women, for older women are now taking to cycling, no doubt to accompany their petrol-bereft menfolk.

### No Meriden Service

**THE** Meriden Service held annually at the **Cyclists' War Memorial** at **Meriden Green**, **Warwickshire**, was not held this year. It was usually held during the last week in **May**.

### Bicycle Run of 1,988 Miles

**A** BICYCLE race of 1,988 miles has been arranged by the **All-Union Society for Physical Culture and Sports**. The start will take place on the **Red Square**, in **Moscow** on **July 18**, the national festival of physical culture and sports, and the route followed will be **Moscow-Minsk-Belostok-Lyov-Kiev-Moscow**. The run is to take 25 days. Participating in it will be forty of the best racing cyclists of the **Spartak Sports Society** and forty racing cyclists of other sports societies.

### New Association Secretary

**OWING** to **R. N. Johnston** having joined the army, the hon. secretaryship of the **Northumberland and Durham Cycling Association** has been taken over by **J. Veitch**, whose address is **18 Jubilee Road, Gosforth, Newcastle, 3**.

### Saving Paint

**WHITE** rubber blocks are being laid by **Leicester highway authority** in **London Road**, between a length of the tram-lines, in order to see if they are more effective than white lines in helping motorists in the black-out. The continual painting of white lines is a considerable expense, and if this experiment proves successful the blocks will probably be laid in other roads in the city.

### Presentation of Awards

**THE** question of the presentation of awards in open events was under consideration at a recent **London West D.C.**

# Paragrams

## Current News Reviewed

committee meeting. In the past the usual method adopted has been to present open prizes at club functions after the close of the racing season.

The committee feels that in present circumstances the prizewinners would appreciate an early receipt of the award. A large number of prizewinners will undoubtedly be unable to attend dinners, or even to select awards, later in the year.

It is therefore suggested that clubs promoting open events should award prizes as soon as possible after the event is held.

### Bicycles for Service Men

**GLASGOW'S** Lord Provost, **Mr. P. J. Dollan**, is to approach cycling clubs in **Scotland** asking their members to assist in a scheme for providing service men with bicycles. Clubs in the area are to be approached in the course of the next few weeks.

The appeal by **Mr. Dollan** is on behalf of the **Glasgow Central War Relief Fund**, and the machines are wanted so that sailors and airmen on shore leave at the **Northern Atlantic patrol base** may have exercise and easy communication with civic centres.

The roads near the base are unsuitable for buses and motor-cars, and bicycles form the fastest mode of locomotion. The first cycle for the first consignment has already been presented to the fund at the **Glasgow City Chambers**.

Clubmen with an old bicycle which is in usable condition, but is not being used at the moment, are asked to notify the **Glasgow Central War Relief Fund, City Chambers, Glasgow**.

### Manchester Rally Planned

**CLUBFOLK**, unattached riders and utility cyclists are invited to join forces with cycle dealers in the **Manchester area**.

Half-price admission to the grounds, with its many attractions, a cycle poster competition with plenty of prizes and numerous other arrangements typical of how we hope to "Carry On, Cycling!" are being considered in order to create a constructive drive that will unite all interested in bicycles and cycling.

### Resilion Brake Price Increase

**THE** price of the **Resilion Anchor Brake** is now increased from 5s. 6d. each to 6s. each.

### Brooks' Saddles

**BROOKS** announce price increases as follow: Spring seat saddles: S22/1, 13s. 9d.; S32/1, 11s. 6d.; S25/NH, 14s. 6d.; S20/1H, 15s. 6d.

### One Hundred Thousand Miles

**ONE** day within the scheduled time, **Tommy Godwin** rode round the **Paddington track** on **Whit Monday**,

*A peculiar design of bicycle.*

completing the last lap of the 100,000 miles which he set himself to complete within 500 days. He already holds the annual mileage record, which he completed on **December 31 last**, with a total of 75,065, and he then rode on to complete the present record. He is fitter at the end of the ride than he was at the beginning. He was received at the **Paddington track** by **Messrs. Keller & Hartwell**, of the **Raleigh Company**, his manager, **Charlie Davey**, **Mr. F. J. Camm** (Editor of "The Cyclist"), and others.

### Collapsible Bicycles

**THE** new military technique of invasion by parachutes has been accompanied by the production of collapsible bicycles—a bicycle-made-in-two! Thus, it packs into a small space and can easily be carried in the restricted space of aircraft. The bicycle played a large part in the rapid advances of German troops in **Southern Norway**. Each infantryman, carried, strapped on his back, a collapsible cycle, which he used in the advance up the valleys from **Oslo**. In spite of the heavy kit carried by the German soldiers these machines enabled them to make good speed on what would otherwise have been a long and tedious tramp. The idea, however, is by no means new. Within recent years the **New Hudson Company** manufactured a machine the frame of which could be taken to pieces so that the whole machine could be packed into a suitcase. Collapsible bicycles were produced over fifty years ago.

### The Sharrow C.C.

**THE** **Sharrow C.C.** extend an invitation to all clubmen and unattached cyclists in **H.M. Forces** to their **Wednesday convivial evenings**, when the club gathers at one of the local hostelrys. These social evenings are appreciated by those now unable to attend the usual **Saturday afternoon and Sunday club runs**.

### Velma Open "50"

**THE** **Velma Open "50"** will be held on **July 7**. Entry forms are now available, and the closing date has been extended to **July 1**. Providing an entry of 75 is received, the awards will remain as in past years. Should this number be exceeded the prizes will be increased, and if less they will be reduced. Awards will be put in hand immediately following the event. Applications to **S. R. Forrest, 1, Glenwood Road, Stoneleigh, Epsom, Surrey**.



# THE MODERN TRICYCLE

## The Technical Side of Tricycle Construction

By G. W. Stratton

decides whether he or she is going to have a "differential" rear axle or a "one-wheel-drive" type.

### The Differential

Most of us know what the differential is and does. It works on the same principle as a car axle and incorporates a compensating mechanism which allows the drive to be transferred continuously to both rear wheels even though one may be turning faster than the other, such as when cornering, when one tyre is not inflated to exactly the same pressure as the other (thereby reducing its effective overall diameter) or when one tyre is worn thinner than the other. The "one-wheel-drive" axle is similar in outward appearance mainly because it is necessary to have both sides joined rigidly together. This object is attained by using a hollow steel "drum" in the centre, joining the two half-axes together. "Divided" axles are



A racing tricycle of the type ridden in modern record attempts. - It is equipped with single-speed fixed gear (or freewheel), sprint wheels and tubular racing tyres. It costs 22 guineas (Claud Butler).

**W**AR with its attendant vital need for economy in all directions on the home front, coupled with such factors as the increased car tax, petrol rationing, the discomfort of travelling by the crowded public transport systems, etc., has not only given an immense stimulus to the popularity of the bicycle, but, in addition has caused an acceleration of the rapidly growing pre-war interest in the modern "three-wheeler." It is safe to estimate that approximately double the number of new tricycles are being sold as compared with last year and a word or two on the subject of modern "trikes" will be of interest to everyone.

Firstly, the weight question. The 1940 tricycle, built by one of the lightweight specialists with high-grade light gauge frame tubing, cutaway lug-work (which actually increases the strength of the frame whilst saving weight), light rims and tyres and component parts, can be supplied ready for the road at inside 30 lbs.! Tricycle frames, though light, must withstand stresses and strains additional to those encountered in a bicycle and it is only by long experience, tests carried out by record-breaking tricyclists and research by technical experts, that sufficient knowledge is gained to select exactly the right gauge steel tubing, the angles of the frame, the correct offset on the forks and all the many details which form part of the highly complicated but simply-operated road model of to-day.

### Front Fork Strain

Think for a moment of the terrific strain borne by the fork blades of a tricycle when cornering. The fork crown, with the weight of the rider increased by the impetus of speed behind it, is trying to overtake the front wheel hub. This in turn is straining, through the wheel spokes, against the grip of the tyre on the road. No wonder it takes experts to design and build them. Between the chain stays and joining these through adjuster sleeves to the rear axle, the old-fashioned tricycle had a solid metal bridge.



A modern lightweight touring tricycle such as is used in increasing numbers. This machine is equipped with a three-speed derailleur gear and costs 20 guineas (Claud Butler).

This superfluous weight has now been cut out by an ingenious arrangement that allows a tubular steel bridge to be utilised and the chain stays now continue right through to the adjuster sleeves.

Previously the tricycle rider had two options. He either rode a fixed wheel or a free wheel and once his machine had been delivered to him from the makers, he could not change the gear ratio. That is to say, not without completely dismantling the back axle and differential. Later the two-speed bottom bracket gear gave some advantage over this state of affairs. Now, however, the tricyclist may have his machine equipped with one or two fixed or free gears, a three-speed or a four-speed; internal expanding brakes can be incorporated in the back axle or drive, the frame can be built to suit his stature and any special or peculiar physical characteristics are all taken into consideration before work is commenced on the actual construction of the tricycle. It is at this stage that the rider

never satisfactory because they lack rigidity at this most essential point.

### One Wheel Drive

One side of the "one-wheel-drive" axle contains the driving shaft, the other forms a "fixed" axle into which the "stub" of the offside wheel hub is fitted. It is not possible to claim advantages for this type apart from the fact that it is much cheaper to produce. On the other hand it is equally true that there are no serious disadvantages and price is a big factor in these hard times! Certain it is that the introduction of one-wheel-drive on adult machines has brought the tricycle within reach of many who would not otherwise have been able to enjoy the delights of three-wheel cycling.

There is a fascination about "trike" riding, something distinct and quite apart from the thrill of two-wheel cycling that we all enjoy. Talk to a tricycle rider about it and you will "feel" his keenness although, like most things, you must try it to know that full, deep satisfaction for yourself.



## AROUND THE WHEELWORLD

By Icarus

A Monthly  
Commentary

### Marguerite Wilson to Continue

**M**MARGUERITE WILSON has joined the staff of Claud Butler. She called upon me the other day to tell me that her object in doing so is not only to attack her own 50-mile record, which she hopes to bring within the two hours, but also to attack the few W.R.R.A. records which do not at present stand to her credit. She states that she intends to make the attempt on the same 50-miles Scottish course on which Earnshaw made his 1 hr. 39 min. 42 sec. record. She will, of course, now be mounted on a Claud Butler bicycle. Another of her duties will be to promote the cause of cycling for women by attending rallies and the various Claud Butler depots, where her advice will be available to all prospective women cyclists as well as to those who are already in its ranks.

By the way, she tells me also that she has resigned from the Bournemouth Arrow Cycling Club. She preferred not to give her reasons for doing so. Sounds cryptic!

### Mr. H. N. Crowe

**I**AM sorry that our old friend Crowe is, if only temporarily, like the suspension of *The Cyclist*, to leave his job with the N.C.U. I have not always seen eye to eye with him, nor with the N.C.U. policy which he, as secretary, was expected to carry out. I often suspected that he did not agree with some of it himself, but the loyalty to the cause which helped him to build up the N.C.U. from the wrecked condition in which he found it when he joined it in 1919, did not desert him when he was compelled to pursue an unpopular policy. There are many benefits now enjoyed by N.C.U. members for which Mr. Crowe was responsible, and I hope that when the war is over he will return

to his old post. The announcement goes that he has been granted leave of absence so that he can take up his position as major in the Pay Corps.

In the latter capacity the hope is expressed that he will still be able to give the emergency committee now in command the benefit of his advice. Mr. A. P. Chamberlin is acting as part-time assistant secretary in his absence.



Miss Marguerite Wilson who has now joined the staff of Claud Butler. She intends to make a further onslaught on the W.R.R.A. records this year.

### The C.T.C. Returns

**I**AM glad to see that the Cyclist Touring Club have returned to their headquarters at Paddington. All communications should, in future, be addressed to the C.T.C. at 3, Craven Hill, London, W.2.

### The American Boom

**T**HE Editor of an American cycling paper sent me a cutting from his journal which shows that cycle trade is booming in America. They are selling one million machines a year, and they are hopeful that this year they will touch the 1½ million mark. The

previous best was in 1899 when 1,200,000 bicycles were sold.

Here is a chance for the British manufacturers to dispose of a large number of machines which they are now expected to export.

### A Five-Speed Hub ?

**A**N official of Sturmey-Archer Gears tells me that they have for some time been experimenting with a 5-speed hub gear. It will be remembered that this company was awarded the C.T.C. plaque in 1939 for their 4-speed hub which was considered the greatest improvement in cycle design, construction, or equipment during the year. Although it is not on the market, an experimental model has been produced and under test has confirmed the ideas of its designer. I look forward to testing one of these new hubs in the near future.

### Lend a Hand

**S**OME of the younger members of cycling clubs are under the impression that their sporting activities should be confined to the grabbing of pots, medals and prizes. When asked to lend a hand as marshalls, etc., they are unwilling to do so. It should be made a part of club routine that members not riding must take a turn at marshalling, feeding, and so on.

### Scottish Youth Hostels Handbook

**T**HE 1940 edition of the Scottish Youth Hostels Handbook, just issued, contains the usual complete information about the Youth Hostels in Scotland. It has been entirely redesigned and includes several new features in the shape of sketches of hostels, an index to hostels and the facilities at each, and a valuable set of road maps of Scotland on the scale of 16 miles to an inch. To meet the needs of the moment, paragraphs are included on rationing and ration cards and on photography regulations. Instructions are given on the procedure to obtain permits for visits to the North West of Scotland, and reference is made to the new schemes for Holiday tours and week-end trips to hostels for new members. An attractive new style of cover emphasises the appeal of the hills. No increase has been made in the usual price of 6d. for the Handbook which is obtainable from any bookseller.

### Cyclist Road Deaths

**I**SEE that the number of cyclists who died as a result of road accidents during April, 1940, was 88, as compared with 106 for April, 1939. Of the total, 15 were cyclists under 15 years of age; in 1939 the corresponding figure was 11.



**TRE VITA BATTERY SAVER BULBS**

MAKE EACH BATTERY YOU USE LAST AS LONG AS TEN

- Ref. G246. 2.5v. with 11½mm. Ball Balloon and M.E.S. Cap for use either for Head or for Rear, or for Torches .. 7½d.
- Ref. G247. 3.5v. with 11½mm. Ball Balloon and M.E.S. Cap for use either for Head or for Rear, or for Torches .. 7½d.

WHEN A BRIGHTER LIGHT IS REQUIRED

**TRE VITA ECONOMY BULBS**

MAKE EACH BATTERY YOU USE LAST AS LONG AS FIVE

- Ref. G246. 2.5v. with 11½mm. Ball Balloon and M.E.S. Cap for use either for Head or for Rear, or for Torches .. 7½d.
- Ref. G248. 3.5v. with 11½mm. Ball Balloon and M.E.S. Cap for use either for Head or for Rear, or for Torches .. 7½d.

WHEN REALLY BRILLIANT LIGHT IS REQUIRED

**TRE VITA BRIGHT LIGHT BULBS**

WILL GIVE YOU THE BRIGHTEST LIGHT PROCURABLE

- Ref. G245. 1.5v. with 11½mm. Ball Balloon and M.E.S. Cap for use either for Head or for Rear, or for Torches .. 7½d.
- Ref. G257. 2.5v. with 11½mm. Ball Balloon and M.E.S. Cap for use either for Head or for Rear, or for Torches .. 7½d.
- Ref. G258. 3.5v. with 11½mm. Ball Balloon and M.E.S. Cap for use either for Head or for Rear, or for Torches .. 7½d.

For REAR LAMPS use

- Ref. G125. 1.5v. with 11½mm. Ball Balloon and M.E.S. Cap .. 7½d.

WITH CYCLE DYNAMOS — TRE VITA "TUBA" GIVE LIGHT AT WALKING SPEED.

Send for Price List. Individual bulbs supplied. No charge for postage. Vitality Bulbs Ltd., Neville Place, Wood Green, London, N.22

# YOU GET THE WORLD'S BEST BICYCLES at



—and Britain's best service... at over 230 branches. Currys' experts are always ready to help you and to ensure that you get the utmost value for your money. Currys have built up an unrivalled reputation for supplying EVERYTHING FOR CYCLISTS at the lowest possible prices.

BRITAIN'S LEADING AGENTS FOR...

**RALEIGH**  
FROM £6.3.9

**TRIUMPH**  
FROM £5.10.0

**HERCULES**  
FROM £4.19.9

**CURRY**  
FROM £3.19.6



EASY TERMS STILL AVAILABLE

★ Ask at your local branch for a Free Copy of Currys' complete new 1940 Catalogue or send a postcard to Currys Ltd., Head Office, Great West Road, Brentford, Middlesex.

There's a Curry Branch near you.

Head Office: Great West Road, Brentford, Middlesex.

"Just in time boss"

"Thanks to you Mr. Fibrax"

It's a wise cyclist who has his brakes fitted with Fibrax Brake Blocks. They never fail to grip in any situation—a sudden stop, a slow down in dense traffic, a safeguard on a hill—it's all the same to Fibrax. Economical, too, they will far outlast any ordinary block. Whatever your make of machine, there's a Fibrax Brake Block to fit it. Ask your dealer.

**BRAKE BLOCKS/ and LINERS by Fibrax**

FIBRAX LTD., 2, Tudor Street, London, E.C.4

# AS AN ENGINEERING PROPOSITION



**CANTILEVERS**  
cost 12/- each, front  
or rear, in nickel or  
enamel finish.



In Chromium finish,  
14/- each.



for TANDEM  
13/- each, front or  
rear, N.P. or enamel.



in Chromium finish  
15/- each.

"CANTILEVER" Cycle Brakes will make an instant appeal. You will see that they appear to form an integral part of the bicycle; they do not obtrude like an ugly excrescence. They are anchored firmly at the point where the force is exerted. Your bicycle will be brought to a standstill smoothly, safely and speedily by the lightest touch of the lever. We offer you the finest and most powerful brakes on the market.

Post this coupon

Please send me your catalogue.

Name.....

Address..... (P.M.)

**THE RESILION CO LTD**  
200, LIVERPOOL ROAD, LONDON, N.I.

*NOW, MORE THAN EVER, A CYCLE IS ESSENTIAL  
FOR TRANSPORT & PLEASURE — and a*



There's a screw in the nose of the saddle. Twist it with a coin, and the seat springs relax or grow taut to suit YOU!



★ **REXINE COVER** gives supple "super comfort." Weatherproof. Many times more durable than any other material of equal thickness.

★ **BRY-FELT LINING** Pure Wool Felt of special texture. Soft, yet supremely tough. Removable rear springs in this Roadster Model enable you to ride on 2, 3 or 4 as desired.

★ **TERRY SPRINGS**—are "shockproof." They keep that strength and elasticity for a lifetime.

# TERRY

## ADJUSTABLE-SPRING SEAT SADDLE

### *is Essential for Comfort!*

People who own a cycle possess the cheapest means of getting about. Best of all, they can fit their machine with a **TERRY** Spring Seat Saddle, and so enjoy "limousine seating" comfort. The **TERRY** Saddle is the only one that can be instantly tensioned to suit any rider's exact weight and riding need—hard enough to satisfy the keenest racing man—or soft enough to give luxurious comfort to riders past the middle age.

● ASK YOUR DEALER TO FIT A "TERRY" TO YOUR CYCLE  
Roadster Model (illustrated) 15/6 Club Model 12/-

FAMOUS  
FOR SPRINGS  
& PRESSWORK  
SINCE  
1855

Patent Nos.  
457373, 454892,  
455169

**HERBERT TERRY & SONS LIMITED, REDDITCH, ENGLAND.**





Without gearing the racing men would not be able to put up the fast times they clock in "25," "50," and "100" events

# Gears and Gearing—I.

By A. W. BRUMELL

## The Merits of Variable Gearing Discussed

**B**EFORE dealing with the various varieties of "gears," it would be just as well to define exactly what is meant by that term as applied to bicycles. When a cyclist says he is riding a 60-inch gear, he means that he is riding a machine so fitted that it will travel forward exactly the same distance for one revolution of the pedals as an Ordinary with a front driving wheel of 60 in. diameter. This method of computation is a survival of the early days of cycling before the advent of the modern Safety. Except for a few tricycles, the majority of racing men then rode the high machine and since their cranks and pedals were attached direct to the front hub, the size of gear they could employ depended directly on their length of leg. The taller the rider the bigger the wheel he could bestride. Hence, it became quite natural for the riders to quote the diameters of their front wheels as the sizes of their gears. Normally, it was a case of the bigger the man, the bigger the gear. It took a really tall man to ride a 60-in. gear in those days! Of course, the actual distance covered per revolution of the pedals was 60 by 3.14 in., or say 188½ in., since the circumference of a circle is equal to 3.14 times the diameter.

### Rear-driven Machines

Naturally, when Safeties, rear-driven by means of a chainwheel, chain and small cog on the rear hub, began to be used, it was desirable to have some method of designation which would enable a quick and easy comparison to be made between the gears employed. The old method of designation was so firmly rooted that it proved unshakable and still survives. It is arrived at by dividing the number of the teeth of the chainwheel by the number of teeth of the cog on the rear hub and multiplying by the diameter of the rear wheel. To discover the distance he will travel forward for each revolution of the pedals, the rider must still multiply the figure so obtained by 3.14.

The size of gear employed will depend, obviously, on the strength and ability of the rider. However, the old timeworn dictum that one's gear should be roughly ten times one's crank length still holds good. For the normal English countryside, it is a gear-size that will enable the average rider to swing along comfortably and easily for most of the time over most of the roads on which his or her ride will take place.

### Hill Climbing

Quite often, however, the rider of a single gear finds himself faced with an apparently unclimbable hill or furiously pedalling his heart out with a roaring gear

behind. One cannot possibly be suitably geared for every eventuality with only one gear to call upon. Some old die-hards still rhapsodise enthusiastically over the rhythmic "revving" of a single gear, getting almost lyrical over the even pedal pressure and the silky running of the unencumbered transmission. They forget the hills on which they have to stamp and pull or, worse still, get off and walk. They forget, too, those wind-assisted stretches when their tiny gears felt half their normal size and their feet felt as though they were treading on air and their legs could not "waggle" at half the speed that was possible. In both cases, as in a host of others that could be quoted, there would be great inequality of pedal pressure to say nothing of an almost complete absence of rhythm and a tremendous waste of energy. I used to be an ardent devotee of this school of thought so that I feel well equipped to enlarge on the advantage of variable gearing, by which the happy rider is enabled to choose, by the mere flick of his finger, a gear to suit the peculiar and immediate requirements of the moment and place and thus really to ensure equality of pedal pressure, to say nothing of constancy of pedalling-speed.

### Variable Gearing

My ideal of variable gearing, which eventually one day I hope to attain, is to have a sufficient variety and number of gear sizes at my command, over such a wide range yet withal so close together, that I may always be able to employ a constant, comfortable pedal-pressure at an even, comfortable rate of pedal revolutions, whatever the conditions and gradient, and yet feel I am getting the utmost possible speed and ease out of my machine. That would indeed be rhythmic riding!

To those who are interested only in increased speed and not in increased comfort, I would point out that speeds in every type of road-race in the world, whether massed-start or time-trial, on flat roads or over mountain passes, have increased in absolutely amazing fashion since the advent of variable gears and few indeed have been the events won or records broken of recent years on a single gear. The greatest and longest cycle race in the world, the 3,000 miles "Tour de France," provided a few years ago a vivid example of the complete supremacy of the variable gear. The track riders were officially designated as "Aces" and denied variable gears, whereas the "Tourist-Routiers," the despised second-raters, were allowed to use them. Their superior equipment more than cancelled out the superior physical ability and experience of "the giants." Many of the most prized and valuable stages fell to them and the reputation of the variable gear was made.

(To be continued)

## Classified Advertisements

RATES.—Twelve words 2s. (minimum). 2d. per word after. Each paragraph charged separately.

### NEW CYCLES

**HOBBS OF BARBICAN**, manufacturers of modern frames, cycles, tandems and tricycles. Specialists in frame design. Lists and individual quotations free. Personal attention to every order.—34, Barbican, London, E.C.1.

**GROSE SPUR** All British Cycles, 75s. Art List 100 models free.—Grose, Ludgate Circus, London.

**BAINES** Super Responsive Cycles. Ultra short W/Base, or standard design models. New catalogue free.—Idle Road, Bradford, Yorks.

### ACCESSORIES

**GEORGE GROSE**, the best house for all cycle accessories. Write for beautiful art illustrated list, post free. 3d.—Ludgate Circus, London.

### CAMPING EQUIPMENT

**CAMOUFLAGE** your tent by brushing on Cranger's Solution CamoBrown and Camogreen, which will waterproof and preserve it without stiffening. 1s. 9d., 3s., 5s. 9d.; 1 gallon, 10s. 6d., treats 240 square feet of 6 oz. canvas. From Scout and Guide shops, camping outfitters. Halfords and stores.

### CLEARANCE SALE

**CLEARANCE SALE!**

**AUSTINS** for Dynamo Sets, 16s. 11d., 18s. 11d., 21s.; postage 1s.

**SPECIAL OFFER** till end of April, Gent's Light Roadster and Sports Cycles (new), £3 19s. 9d.; right price, £5 10s.; 3-speed gears, 21s. extra. Send small deposit to secure one. Exchanges.

**SMALL QUANTITY** of Genuine Met. Police Capes. 6s. 3d., postage 1s.; also genuine Met. Police blue waterproof Trench Coats, 14s. 11d., postage 1s. 3d.

**ALL** types of Tail Lamps, complete with brackets, 2s. 3d. to 3s. 9d.; postage 6d.

**ALL** types of Batteries, No. 8, U2, 1829, 1839, flat, 7d. per doz. postage. English and Foreign.

**AUSTINS**, 147-153, High Street, Harlesden, N.W.10. (Wilkesden 2099).

### CYCLES WANTED

**MORRIS** pays top prices for old cycles, ladies' and gents'. Cash waiting at door. Any condition.—Morris, 89, Tottenham Court Road (middle). (Museum 4910.)

### GEARS

**PERCY FREEMAN**, Specialist in Derailleur and Hub Gears; also B.S.A., Raleigh, Sun. Dawes, Rudge and Gazelle in stock.—109, Brownhill Road, Catford, S.E.6. (Hither Green 2779.)

### INSURANCE

**ASK** your dealer for one of our Insurance Certificates; or write direct Vehicle and General Insurance Co., Ltd., Royal Liver Buildings, Liverpool.

### LADIES' AND GENT'S CYCLES

**MORRIS** for used, secondhand and shop-soiled bargains from 30s. Big range, good makes. Deposit secures. Agents all makes.—Morris, 89, Tottenham Court Road (middle).

### TYRES

**10,000 NEW TYRES**. Clearance, best makes, 93% off standard prices. Carriage paid. Price List on application.—Davies, Tyre Factory, Wednesbury.



## SPECIAL CYCLE OFFER

**LIGHTWEIGHT TOURER.** Dunlop Tyres; R.L. Brakes; N.B. bars; rubber Pedals; Chrome plated. Splendid appearance.

**GENT'S £3.15.0**  
**LADY'S £3.19.6**  
**SPORTS MODEL £3.12.0**

## 10/- DEPOSIT

The most inexpensive and convenient means of travel — no petrol or tax worries. Purchase now. On similar terms: English, Rudge, Sunbeam, and Coventry Cross.

**PRIDE & CLARKE LTD**  
153 STOCKWELL ROAD, S.W.9 (BRI 6251.)

**THE CYCLOMETER MANUFACTURERS**

Standard Model - 2/11 each  
De Luxe Model - 3/6 each  
To Fit 24", 26" or 28" Wheels.

**H. J. Thormann Engineering Co. Ltd.,**  
PERREN STREET, LONDON, N.W.5.

Chromium Plated  
**BRITISH MADE**

# WAYSIDE THOUGHTS

By F. J. URRY



## No need for Mile Piling

I WANT to make that plain to everyone, and especially to the younger folk, for I have been frequently told by them that the supreme joy of cycling consists in the distances they can cover in a limited amount of time. You and I know there is a type, and not an uncommon one, that places a higher value on the gathering of miles than the loveliness and beauty of vision to be achieved by lingering along the leagues. I do not decry the splendid athleticism of thousands of my young friends, and that they revel in it is merely a shadow of my own youthful adventures; but the exuberance of their expressions on the fun of achieving distances sometimes reacts on the less agile cyclist and makes him wonder if all this vigour is worth while,

or whether it would not be better to obtain some other type of vehicle if the be-all and end-all of travelling is to chase the leagues most week-ends. You, in your virulent youth, may laugh at this notion; but I look down the long list of my friends, men and women little more than half my age, and I see so many of them who have fallen away. And I wonder often if they would have tired of the saddle and the pedals had their attachments been with the less active people. A case in point comes home to me, where a few evenings ago a man rising forty admitted he often found it uncomfortably vigorous to hold the youngsters all day, and as a result discovered his interest in the club run, as such, was certainly fading. He talked quite sensibly of other means of locomotion, because to him cycling for a couple of decades had been the club run and all the social and active interests the club run connotes. I believe this is one of the reasons, and possibly a main one, why so many old cyclists slip out of the game. They have never learned to become "unattached" riders, and to substitute for the jolly crowd of young folk the easier company of a few old friends, or the loneliness of a day along the road when everyone and everything becomes your friend in interest, and the glory that is cycling's freedom really enters deeply into your soul. Only those of us who have grown old in the game will know exactly what I

mean; but as you grow older I would ask you to remember these things.

## No One Rule

A FEW days ago, like a dutiful parent, I rode my daughter's bicycle home from the repairers, and though it is only a matter of five miles, yet I never had a more uncomfortable journey. It was, of course, largely my own fault, for I was too lazy to adjust the saddle height let alone lower the handlebars, so I sat all hunched up like a round of beef, and rolled home painfully slowly. Having got there I persuaded the lady to let me see her seated on the machine, and lo and behold! it fitted comfortably and easily, and to be candid, I would not have imagined any human being could have ridden that machine with grace or ease. Which only goes to show we should be careful in our criticisms when we see folk awheel, and not to be too prone to alter their position until we are quite satisfied an alteration will achieve better results. During my time I have given cycling advice to thousands of people, basing that opinion on my own comfort, and from results given me have found such advice has been generally accepted; but this recent trail of aching legs and hunched shoulders has made me realise more than ever that there is no fixed rule for the positioning of people awheel, for the acquirement of ease and comfort combined with dignity and grace.



## "OWING" TO WILLIAM THE CONQUERER

Historians tell us that quite a lot of taxes were owing from the comparatively small population of England in 1066.

But to-day, millions of cyclists owe (gladly) everything to Williams—the Conquerors of Transmission Troubles—because their strength is not "taxed" by cycling the "Williams" way. So they pay tribute to Williams in enthusiastic recommendation.



EDWARD WILLIAMS, FOUNDRY LANE, BIRMINGHAM

FIT SAFETY . . . FIT

# Monitor

THE BRAKES  
THAT MAKE  
CYCLING SAFE

7/9  
each

5/6  
each

Manufactured by

THE MONITOR BRAKE CO.  
Monitor Works, Birmingham 6



SUPER CAM

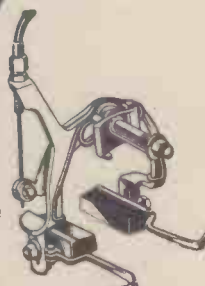

CLIMAX

W.H.W.

Carefree Camping for Cyclists with . . .

## NEWNES CAMPERS' HANDBOOK

By DAVID BALFOUR

How to get the most out of a camping holiday—cheaply and successfully. With all you want to know about tents, sites, camp-cooking and the problems that beset the beginner. There are special chapters on cycle-camping, hike-camping and caravan-camping.

From all booksellers, 2/6, or by post 2/9 from the publishers,

**GEORGE NEWNES, LTD.**  
(BOOK DEPT.)

Tower House, Southampton St., Strand, London, W.C.2

# BUY, EXCHANGE OR SELL

Advertisements are accepted for these columns at 3d. per word (minimum 12 words at 3s.—advertisements of less than 12 words are charged at the minimum rate of 3s.) subject to a discount of 2½% for 6 consecutive monthly insertions or 5% for 12 consecutive monthly insertions. TERMS:—Cash with order. Cheques, Postal Orders, etc., should be made payable to George Newnes, Ltd. The Proprietors reserve the right to refuse or withdraw advertisements at their discretion. All advertisements must be received on or before the 5th of the month preceding date of publication and should be addressed to the Advertisement Manager, "Practical Mechanics," George Newnes Ltd., Tower House, Southampton Street, Strand, W.C.2.

## LITERATURE

**160 PAGES ILLUSTRATED REVISED WORK-SHOP HINTS** and Calculations in Calvert's Mechanics' Handbook, 8d., post free.—Sherratt & Hughes, St. Ann Press, Park Road, Timperley, Ches.

## MISCELLANEOUS

**WANTED FOR PROMPT CASH.** Miniature Cameras, Enlargers and Accessories, Cine Cameras, Projectors and Films, Microscopes, Telescopes and Binoculars. Small Lathes and Precision Tools.—Frank's Camera Exchange, 67 Saltmarket, Glasgow.

**BUILD YOUR OWN WIND CHARGER** and make free electricity. Drawings and instructions, 2s. 6d.—Pearse, Middle Taphouse, Liskeard, Cornwall.

**TELESCOPES, MICROSCOPES,** Scientific Instruments, etc. Send for lists. Sale or Exchange.—C. V. Bolton, F.S.M.C., 49a Leigh Road, Leigh, Lancs.

## MUSICAL INSTRUMENTS

**BAND GUIDE.** Hints on the Bugle, Drum, Flute, Staff Parade formation, etc. Free, post paid.—Potter's (Manufacturers), West Street, London, W.C.2.

## JUBILEE WORM DRIVE HOSE CLIPS



The long-life clip with the ever-tight grip

*The Best Known*  
For Radiator Joints, Air, Oil, and Water Hose Joints

We guarantee a Tight Joint

Stocked by all Garages and Accessory Dealers

L. ROBINSON & CO.,  
25, London Chambers,  
GILLINGHAM, KENT

*It's easier to solder with*

"Baker's" Solderine. For all electrical work and wherever paste flux is preferred. Popular sizes include: 2 oz. tins 6d.; 4 oz. tins 8d. Also supplied in bulk. Obtainable from all wholesalers

**Baker's SOLDERINE PASTE**

Sir Wm. BURNETT & Co. (Chemicals) Ltd.  
Great West Rd. Isleworth Middx.  
TEL. HOUSLEIGH 0470

## OUR ADVICE BUREAU COUPON

This coupon is available until June 29th, 1940, and must be attached to all letters containing queries, together with 3 penny stamps. A stamped addressed envelope must also be enclosed.  
PRACTICAL MECHANICS, JUNE, 1940.

## MODELS

**WATERLINE MODELS.**—True scale Naval Constructional Kits. H.M.S. Hood, Nelson, 4s. 6d. each; Ajax, Achilles, Exeter, 3s.; Cossack, 2s. 6d., etc. Prices 1s. 6d. to 4s. 6d. List post free.—Waterline Models, 77 Grosvenor Road, London, S.W.1.

**RAILWAY BARGAINS** ("0" and "00"). Also other toys. Send 6d. for catalogue.—Below.  
**WANTED FOR PROMPT CASH,** Trix, Dublo, and Marklin "00" Railways.—Georges', 11 Friars Street, Ipswich.

## MODEL AIRCRAFT

**WOLVERHAMPTON.**—Wolverhampton's aeromodellers' rendezvous. **START and SONS,** 61 Victoria Street. Kits by all the popular makers, petrol engines, etc., selected balsa wood, spruce, cements, dopes, rubber, etc., and the most complete range of materials and accessories.

## PHOTOGRAPHY

**PHOTOGRAPHIC MATERIALS.** Plates, films, mounts, chemicals. Interesting money-saving lists free.—"Kimber's," 105 Queens Road, Brighton.

## FOR SALE

**THREE NEW VOLUMES CAXTON'S.** Cost £3. Offer accepted.—Box No. 134, c/o PRACTICAL MECHANICS, Tower House, Southampton Street, London, W.C.2.

## PATENTS AND INVENTIONS

IF YOU have an invention write for particulars of my service.—B/M. Grail, London, W.C.1.

## CHEMISTRY EXPERIMENTS IN YOUR OWN LABORATORY



Post Free OFFER of SAMPLE PARCEL containing many useful pieces of

**CHEMICAL APPARATUS**  
**2/9**

Write also for FREE PRICE LIST of other Sets.

**BECK** (Scientific Dept. A), 60, High St., Stoke Newington, London, N.16.  
Booklet, "Experiments in Chemistry," 6d. P.O.

## INTRODUCING A NEW, IMPROVED, UNIVERSAL DE-LUXE ENGINEERS' THREAD CHART

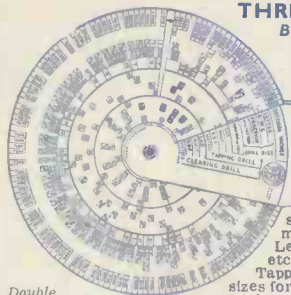

Beautifully Finished White Celluloid. Diameter 3½ Ins. ONLY 1/6 POST 3d. EACH

Drilling, Tapping, Clearing. All sizes and equivalents up to 1 in. at a glance. Sizes, decimals, inches, standard wire gauge millimetres. Drills. Letter sizes, S.W.G. etc. Threads per inch. Tapping Sizes. Clearing sizes for above threads. Imperial and Metric. Satisfaction or money refunded.

Double sided  
**BRITISH SLIDE RULE CO. (Dept. 65), 16, BARTER ST., HOLBORN, LONDON, W.C.1.**

## SITUATIONS VACANT

**AERO AND ENGINEERING INSPECTORS, VIEWERS,** etc. Work of National Importance and Reserved Occupations for men over 21. For FREE GUIDE to rapid preparation and Employment Service for these vacancies, apply National Institute of Engineering (Dept. 372), 148 Holborn, E.C.1.

## WATCHMAKING

**WATCH & CLOCK REPAIRERS.** Send 4d. for complete list of material and tools.—Blakiston & Co., Ainsdale, Southport.

## 3½ MYFORD 3½

**BEST VALUE—INEXPENSIVE**



SUPPLIED TO NUMEROUS LARGE WORKS AND INSTRUCTIONAL CENTRES, ETC.

Bench - Treadle - Motorised Lathes & Accessories

Send P.C. for free illustrated list (your tool merchant's address would be appreciated)

MYFORD ENG. Co., Ltd., Beeston, Nottingham

## An Absorbing Hobby

BUILDING A STUART MODEL IS AN ENGROSSING PASTIME, AND THE RESULT A CONTINUOUS PLEASURE



We illustrate:

STUART NO. 10. High Speed Steam Engine. Bore ¾". Stroke ¾".

Each set is quite complete—drawings and instructions are included.

If you have a lathe—  
The rough castings . . . . . 8/6  
If not—  
Fully machined set . . . . . 19/6  
Ditto, with all holes drilled and tapped . . . . . 25/-

This and many other Stuart engines are fully described in the 72-page CATALOGUE No. 3, 6d. post free.

**STUART TURNER LTD. HENLEY - ON - THAMES**

# GAMAGES

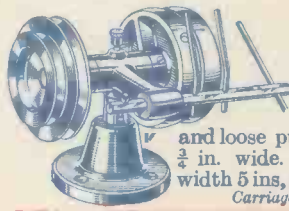

## SMALL COUNTERSHAFTS At an Exceptionally Low Price

These comprise a two-speed grooved pulley 2½ x 3½ ins. diameter for ¼ or ⅜ in. round belt, a pair of fast and loose pulleys, 3½ ins. diameter x ¾ in. wide. Overall length 5½ ins. width 5 ins., height 4½ ins., weight 8 lb. Carriage 1/- England or Wales.

**16/6**

## ALUMINIUM REPAIR OUTFITS

Keep your aluminium ware, castings, etc., serviceable indefinitely with one of these inexpensive repair outfits. Will fill, effectively, holes in aluminium castings, or repair any aluminium article. Contents: 1 lb. B.E.L. metal, 1 tin aluminium flux, 1 steel wire brush, 1 tin preservative and brush, 1 bottle penetrator and brush, and 1 spreader. Complete in strong wood box—12 by 6 by 1½ in.—with full instructions. Post 9d.

**5/4**



AT WELL BELOW  
MAKER'S LIST PRICE

## 1/8 h.p. CROMPTON PARKINSON CAPACITOR START A.C. MOTORS

Brand new. Suitable for driving lathes up to 3½ in., and similar machinery. 1,425 r.p.m. For A.C. 220—250 volts. An opportunity not to be missed.

**67/6**

OR DELIVERED  
ON FIRST OF  
SIX MONTHLY  
PAYMENTS OF  
**12/6**

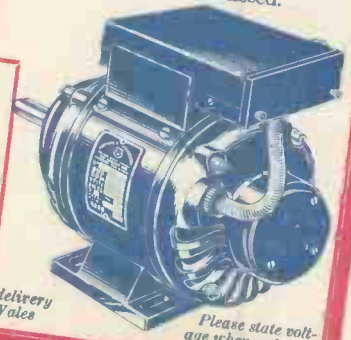

Carriage (outside our free delivery area) 1/6 England and Wales

Please state voltage when ordering



## BOXES OF TWELVE ASSORTED FILES

The best and cheapest way to buy Files. British made and excellent quality. Sizes 6 to 12 inches. Post 9d.

**12 for 5/6**

Also sizes 4 to 8 inches. 12 for 3/3. Post 6d.

## SOCKET SPANNER SETS

Made from special alloy steel, oil hardened and cadmium plated. Six sockets, complete with double-ended ball loaded crank handle. Sizes: ⅜, ½, ⅝, ¾, 1, and 1½ in. Whitworth. PER SET



**3/9**

Post 6d.

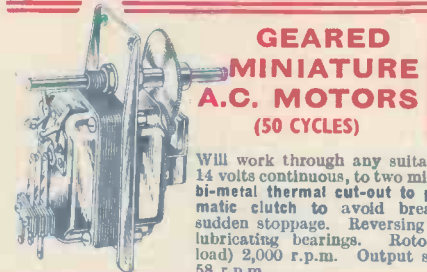

## GEARED MINIATURE A.C. MOTORS (50 CYCLES)

Will work through any suitable transformer. Rating, 12 to 14 volts continuous, to two minutes at 24 volts. Incorporating bi-metal thermal cut-out to prevent overheating, and automatic clutch to avoid breakage under sudden stoppage. Reversing switch, self-lubricating bearings. Rotor speed (no load) 2,000 r.p.m. Output spindle speed 53 r.p.m.

**7/6**

Post 6d.

## COMBINED TRANSFORMER and BELL



This compact, trouble-free outfit is easily fitted, and does not interfere with radio. Bell can be set to ring loudly or softly. For A.C. mains 200-250 volts. Wiring diagram supplied. Exceptional value. **5/11**

Post 6d.

## ELECTRIC BURGLAR ALARM

Fits to the top of any door and rings a powerful electric bell immediately door is opened, and continues until door is closed. Easily put in or out of action by pulling cord at side. Takes ordinary 4½ volt re-charge battery. Complete with battery. **5/6**

Post 6d.

## INSULATED PLIERS



Tested to 12,000 volts.

Strongly made, insulated with thick rubber. In two sizes: 7 in., 2/6. Post 6d. 6 in., 2/-. Post 6d. To-day's Value 3/- and 3/9.



Made in France

## COLUMBUS PATTERN GAUGES

To take inside, outside, and depth measurements. Graduated 5 ins. and 120 mm. and provided with two verniers which give English and Metric readings

**3/9**

Post 6d.

## POLISHING, BORING AND GRINDING HEAD



British made and offered at much below original price. Height 7 in. Total length of spindle, 10 in. Chuck capacity, ¾ in. Weight 7 lb.

Post 11d.

**17/6**

## Heavy Duty, Block Type CONDENSERS

1 MFD. Capacity. Suitable for voltages up to 1,000 A.C. or 2,000 D.C. Tested to 4,000 volts D.C. Dimensions approximately 4½ in. wide, 9 in. overall height, ½ in. thick, Bakelite case.

**2/6**

Post 6d.

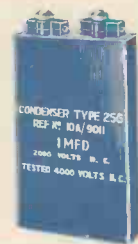

## SURFACE GAUGES

Accurately made and fitted with fine adjustment device. Overall height 12 inches. Diameter of base, 3½ inches

**9/4**

Post 6d.

TOOL BARGAIN LEAFLET FREE ON REQUEST



## SUPER QUALITY STOCKS and DIES

Made in U.S.A.



by Russell Manufacturing Co.

Adjustable dies in 2½ in. diameter collets, cutting ¼, ⅜, ½, ⅝, ¾, 1, and 1½ in. Whitworth threads with a taper tap to each size. Complete with die holder and tap wrench.

Packed in a strong wooden box. **£5.17.6**

OR DELIVERED FOR 23/- DEPOSIT BALANCE IN SIX MONTHLY PAYMENTS OF **17/3**

Carriage (outside our free delivery area) 2/- England and Wales

## HIGH SPEED ELECTRIC HAND DRILLS

A high-grade tool with exceptionally fast penetrative power. Takes up to ½ in. drill. Gamages price is substantially lower than that asked for similar drills elsewhere. Complete with good length of flex and adaptor. For 200/240 volts A.C. or D.C. Post Free. Please state voltage when ordering.

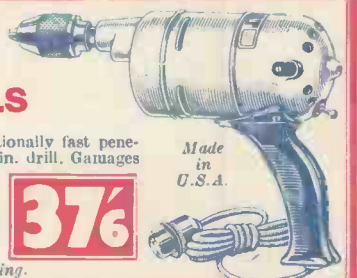

Made in U.S.A.

**37/6**