

**MARVELS OF THE CINEMA ORGAN**

**NEWNES**

# **PRACTICAL MECHANICS**

**JANUARY**

**6<sup>D</sup>**



**GUIDING AIRCRAFT BY WIRELESS - HOW MAPS ARE MADE -  
HOME-MADE BURGLAR ALARMS - HOME-MADE ANILINE DYES -  
BUILDING A 15c.c. PETROL ENGINE - EXPERIMENTS IN PHOTO-ELECTRICS  
BINDING PERIODICALS - PEARL DIVING - PATENT ADVICE - WIRELESS ETC.**



# Practical Mechanics

VOL. II. No. 16  
JANUARY  
1935



Edited by F. J. CAMM

## SUBSCRIPTION RATES :

Inland and Abroad, 7s. 6d. per annum

Canada - - 7s. per annum

Editorial and Advertisement Offices : "Practical Mechanics," George Newnes Ltd., Southampton Street, Strand, W.C.2.  
Registered at the G.P.O. for transmission by Canadian Magazine Post.

## Notes, News and Views

### The Latest French Submarine

THE *Minerve*, a new French submarine of 600 tons, was recently launched from the Cherbourg Naval Dockyard. It is 213 ft. in length, 16 ft. in breadth, and its armament will consist of one 75 mm. gun, one machine gun, and eight torpedo tubes. The vessel is designed for a speed of 14 knots on the surface and 10 knots submerged.

### An Automatic Pilot

THE "auto-pilot," a new self-flying apparatus for aircraft, was recently demonstrated in Berlin. It is stated that it can keep an air liner flying at a given height and speed without human control for a considerable length of time. If the engine stops, it automatically puts the plane into a glide. A fully illustrated article describing how the "auto-pilot" works appeared in the July, 1934, issue of PRACTICAL MECHANICS.

### Photographing a Heart-Beat

BY means of a wonderful appliance known as an electro-cardiograph it is now possible to photograph a heart-beat. The instrument embodies a cathode ray oscillograph, and when in use a doctor simply attaches contacts to the wrist and leg of the patient, and turns on the current, when across a sheet of frosted glass a zig-zag line appears corresponding to the patient's heart-beats.

### A Road made of Steel

EXPERIMENTS are being carried out with a form of steel road construction which is primarily intended for military purposes. The method adopted makes use of a series of pressed steel channels which are laid across the road, side by side, so that the shaped flange along the edge of one channel interlocks with the adjacent flange of the next one. The channels are made of steel of uniform thickness from  $\frac{1}{4}$  in. to  $\frac{3}{8}$  in. according to the nature of the load to be carried. It is claimed that this new form of road construction can be rapidly laid over soft or marshy ground, thus providing a hard surface and facilitating transport.

### New Swiss Power Station

WHAT is claimed to be one of the largest plants of its kind in the world is nearing completion in Switzerland. This is the Dixence hydro-electric power station, comprising five groups, each having one alternator driven by two Pelton wheels. Each group will be capable of producing 21,250 h.p.,

and the power will be distributed over an area of about 4,350 square miles.

### Aligning a Swing Bridge by Light Rays

A NOVEL device is being used in the U.S.A. to indicate when a 300-ft. span of a swing bridge is exactly lined up upon

### THE MONTH'S SCIENCE SIFTINGS

*A Cierva autogiro recently gave a demonstration of landing and taking off in one of the main streets of Paris. It took off with a 50 yds. run, and when landing it stopped within 30 yds.*

*According to a recent report the Fuel Research Board is experimenting with the production of motor spirit from rubber by the action of hydrogen under pressure.*

*The Governor-General of New Zealand, Lord Bledisloe, by pressing a button at Government House, Wellington, 12,000 miles away, started by wireless the machinery in Harland and Wolff's shipyard at Belfast which launched the liner "New Zealand Star."*

*A plant for the production of non-poisonous coal gas has recently been put into service at Hamelin, in Germany. The process consists of converting the carbon monoxide content of the coal gas into carbonic acid and hydrogen by treatment with steam.*

*The world's largest welded bridge, across the River Abushka, at Stalinsk, was recently tested, and opened for traffic. At its widest span the bridge is 85 m. and the width 18 m.*

*A huge new French seaplane, being constructed at Toulouse, and destined for the South Atlantic service, will be capable of 160 m.p.h. It will carry thirty passengers and a crew of eight, and, fully loaded, will weigh 37 tons.*

closing. A photo-electric cell is placed on the end of the span, and a light source on one of the piers. When the ray of light strikes the photo-electric cell a green light is shown on the control bench and a circuit is completed so that the end wedges can be driven in.

### Diesel-engined Flying Boat.

ACCORDING to a recent report, a British flying-boat, a Blackburn *Iris*, is to be

fitted with heavy oil engines. The three Diesel-type engines to be used are 720-h.p. "Culverins," made by Napiers. They are six-cylinder in-line engines, and weigh no more than 2½ lb. per horse-power. Among the advantages claimed for this class of engine is avoidance of magneto troubles and economy in fuel consumption and fuel cost.

### A High-speed Aeroplane

A NEW type of racing plane in which it is proposed to fit a "V" type, 16-cylinder, 2,500 h.p. engine, has recently been designed by Mr. K. Rider, a designer of some repute. Despite its powerful engine, however, the machine will be built on very small lines. The span is only 26 ft. 8 in., and the overall length 27 ft. 9 in., and its approximate weight will be 3,000 lbs. The plane will have a landing speed of 85 m.p.h., and the take-off is facilitated by a variable-pitch propeller which will be incorporated in the design. The cooling of the engine will be carried out by circulating steam, under pressure, through a heat-removing condenser. With a 9-in. pitch propeller at wide-open throttle, the engine consumption is 1 gallon of petrol every 15 seconds, and only enough fuel can be carried for a flight lasting forty minutes. During this short space of time, however, it is estimated that the aeroplane will have travelled 300 miles.

### Measuring Light Intensity

LIGHT intensity in the home can now be read as easily as the temperature with a new device known as a light meter. Its principal purpose is to measure and register the direct intensity of the light in any room, on the proven theory that light, the same as temperature, has a mental as well as a physical effect on humans. The same amount of illumination in a room can be varied by means of different shades of wall-paper. This meter measures the illumination, and registers the correct amount of light necessary for various purposes.

### Tree Surgery

THE Goodyear Tyre and Rubber Co. have now perfected a plastic rubber tree cavity filler, which readily adheres to the cavity or scars of damaged trees, and prolongs their life indefinitely. The cement is supplemented by a new paint for minor cuts and scars which covers cuts resulting from pruning and trimming.

# THE MECHANISM

## ❖ CINEMA ORGAN

Although the cinema organ of the types now were unknown to organ builders a general knowledge and experience possessed by the country has gone far to make the



A front view of an organ, showing the illuminated panels on each side.

THE adaptation of electrical mechanism to the organ has made vast strides in recent years. Many devices hitherto unthought of have been brought into service, developed and perfected. The hundreds of pipes, percussions and effects can be efficiently controlled from a comparatively small console placed at any reasonable distance from the organ itself, which is only made possible by this form of action. The production of new tone-colours featured in most modern organs, and the improvement of those already in use, is a never-ending quest, and the object of almost continuous experiment. The mechanism which makes it possible for one individual to operate so many different tone-colours and effects is necessarily of a very intricate nature. It involves many thousands of contacts, wires and soldered joints, besides hundreds of different points where circuits are controlled by multiplex switches devised for the purpose. The electro-magnet is probably the most important unit in the organ's mechanism as through its medium the action is ultimately set in motion. Of special design, it is capable of forty repetitions a second, which is, of course, consider-

ably faster than any human being can play. The electric contacts throughout the main relay and the console are made of standard silver and are housed in holders made of maple wood. The main cables between the console and the organ are of very strong construction, double cotton covered, enamelled, bound, and finally insulated.

### Second Touch Control

In all but a few cases, at least two of the keyboards, or manuals as they are called, are fitted with second-touch control. This means that by pressing through first touch to second touch a second and quite distinct tone-colour or effect can be produced from the same rows of keys. Ten single or double-touch thumb pistons are arranged under each row of keys, which make it possible for the organist, by pressing any piston, to alter immediately the combination of stops, and produce an entirely different effect. Furthermore, by means of a control board placed at the back of the console, any

combination of stops can be arranged on these pistons at the will of the organist.

As a further means of control, each department of the organ is fitted with a



Action relays and switch boards, in course of construction.

cancel bar, by the depression of which all stop keys on that manual are immediately returned to the normal position, and all stops become dumb. By a complete system of coupling, any one manual can be connected to the pedal organ if required. A full range of orchestral effects is also controlled from the keyboard. These effects are distributed over the various manuals and the pedal-board, the drums, cymbals and triangle on the former, and the Chinese block, castenets, etc., on the latter.

### Special Intermanual Couplers

These couplers are fitted to various organs to augment the usual unison couplers, and are sometimes controlled by first or second touch. For instance, solo octave to accompaniment second touch, or accompaniment sub-octave to great first touch, enables the organist to produce quite unique effects.

The Pizzicato key control is capable, in the hands of an experienced organist, of producing effects which are bewildering to the listener. The pluck of a string or the lipping of a trumpet can be imitated, effects which, but for this device, would be impossible. From this it will be seen that these expression controls at the organist's finger-tips bring almost any imaginable effect within range.

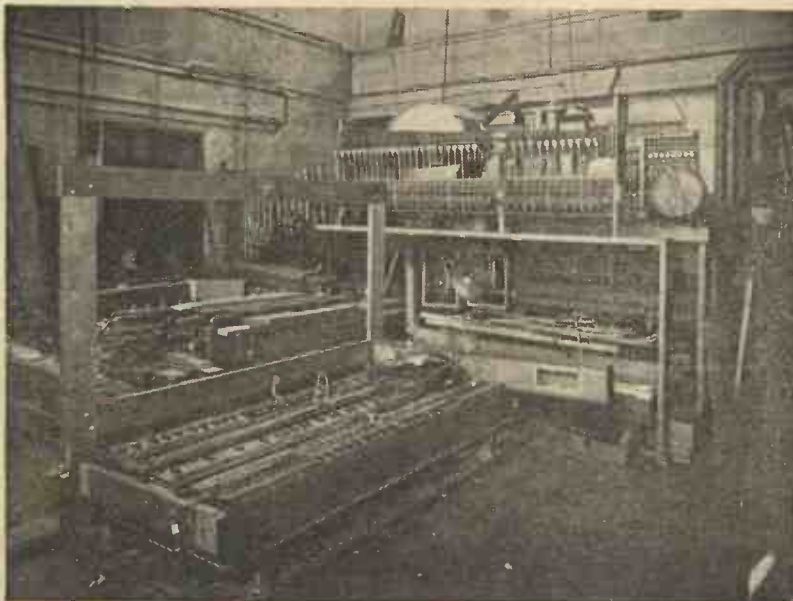

Behind the scenes during the erection of a cinema organ, showing the xylophone, glockenspiel, bass drum, snare drum, cymbal and tom-tom. Unit wind chests are also shown in the foreground.

# OF THE MODERN EXPLAINED

used Includes so many innovations which tion ago, the value of the fundamental the oldest-established organ builders in cinema organ such an outstanding success.

Besides the control of the various organ tone-colours—wood-wind, brass, etc.—there are also provided suitable controls for percussions, drums and other effects. Placed in either the solo or accompaniment chamber of the organ, these percussions and effects are operated by electro-pneumatic action. The drum-sticks, for example, are attached to pneumatic motors operated by electro-magnets, which work with such rapidity as to produce the snare drum or bass drum roll. The former drum is controlled by the manual keys, and as long as the key is depressed the drum will

### Tone-Colours

The number of different tone-colours in an organ depends, of course, on its size and the requirements of the theatre. It does not follow, however, that an

over-poweringly loud organ is large, as certain fundamentals must form the

basis of all properly drawn-up theatre organ specifications, otherwise power, balance and dignity will be sacrificed. Given the fundamentals, a specification can be enlarged to almost any extent, in order to secure variety of tone. Solo stops, such as clarinet, oboe, vox humana, saxophone, French horn, English horn, trumpet and tuba, all go to build up a truly magnificent instrument, capable through the controls mentioned above of almost any variation of tone.

Diapasons, strings, flutes, diaphone and diapason basses, augmented by reeds, produce the fundamental organ tone, and by use of the unit system of construction, which is general throughout all Christie organs (which illustrate this article), these fundamental ranks are fully extended to form bass and treble registers of

suitable strength and balance. The treatment and voicing of this side of the instrument is an all-important and delicate task, because besides being fundamental, some of the stops are also accompanimental.

### Voicing

This is the art of making the pipes "speak." When the pipes are received by the voicer they are quite "dumb" and no sound whatever can be obtained from them. Voicing is a very delicate job and is divided into three quite distinct departments—flue stops, reed stops and tonal percussions. In flue

stops the tone is produced on much the same principle as in a tin whistle, but in reeds, the tone is produced in various forms of reed made of carefully selected brass, vibrating against a brass "shallot." Percussion tone is produced from the actual instruments themselves, which consist of metal or wooden bars of different sizes, fitted with resonators. The bars are struck by specially made hammers. Under the heading of flue stops are such stops as tibia, open diapason, viol d'orchestre, flute, celeste, etc. By manipulation of the lip, languid and windway, the pipes are made to speak, and through the medium of a

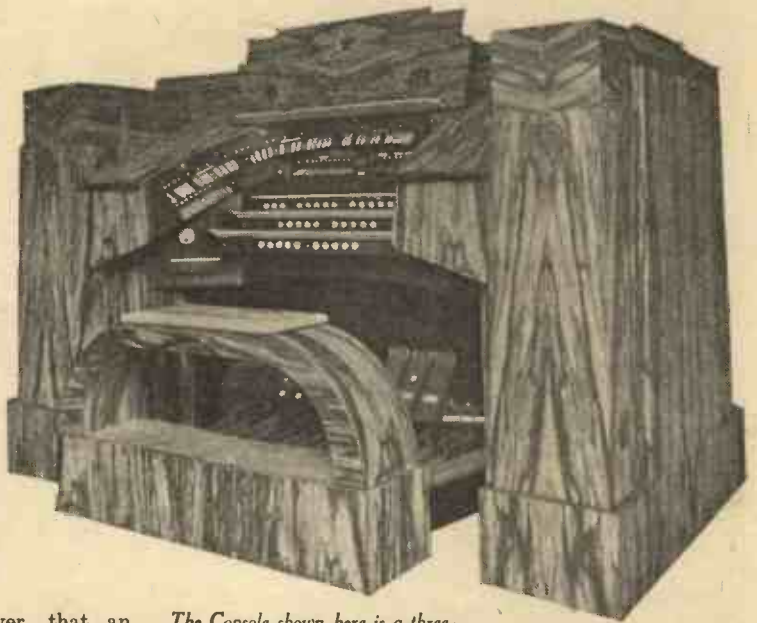

The Console shown here is a three-manual "Christie" organ with a casework of wax-polished marble ebony. This unique and modern design was specially chosen to harmonise with the architectural surroundings of the theatre in which it was installed.



The accompaniment bourdon, flute, diapason, etc.

keep on rolling. The bass drum, cymbal crash, triangle, etc., are controlled from the pedal keys. The same principle is used for tonal percussions, such as a harp, marimba, xylophone, glockenspiel, chimes, vibraphone and chrysoglot. Some require a single blow; others, such as xylophone and glockenspiel, are fitted with a reiterating action as well as a single action. Other effects, such as surf, telephone bell, bird whistle, syren, boat whistle, etc., are operated by stop keys in a special position over the solo keys. The consoles are fitted with crescendo pedal indications, a clock and a voltmeter. The external casework is designed in association with the theatre architect to suit the architectural scheme of the theatre. Almost unlimited designs are available. The console is usually placed on a rise-and-fall platform in the orchestral enclosure.

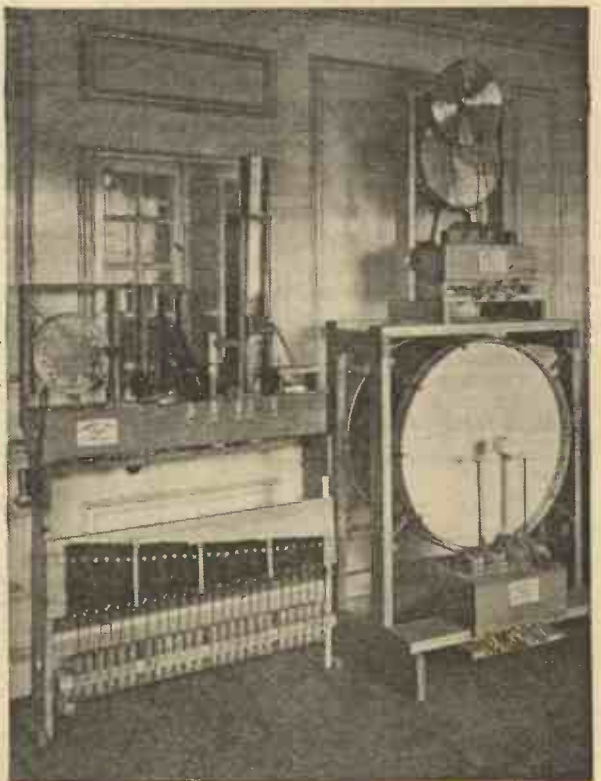

Showing the numerous instruments that are operated by a cinema organ.



A view of the keyboard of an organ showing the large number of controls and notes the organist has to operate.

voicing machine, which is really a miniature organ, each one is treated, cut to pitch length, and balanced against its neighbour. Every stop in the organ is sealed and voiced for the particular theatre in which it is to be installed. In the voicing of reeds, among which are the clarinet, oboe, saxophone, tuba and trumpet, the operation is more complicated and intricate. The reed voicer is responsible for selecting the brass for the "tongues" for cutting it to the exact shape and size required, and for so curving each "tongue" and "loading" it so as to produce the tone required by the voicer.

**Tonal Structure and Scales**

The power and balance of a theatre organ are dependent to a large extent on the scale of the various stops which go to make up the specification; wind pressures also play a large part, and Christie organ scaling is very large and the wind pressures employed are high. Scale is the organ builder's term

for diameter, and the expression 7-in scale means that the lowest "C" of the stop measures 7 in. across the top. When the specification of the organ has been decided upon, it is a tonal specialist's business to set down against each stop the scale to which it shall be made. He has as many as twenty or more scales in one stop alone from which to select, and from this it will be seen that the scaling of an organ requires experience and judgment. In unit organ construction, where numerous tone-colours are secured from comparatively few ranks of pipes, the specification can be very deceptive.

**The Position of the Organ**

In order to obtain the best results from any organ the question of position must be considered. The finest and most complete organ can be ruined by accommodating it in the wrong place. The organ "voicer" can, however, overcome to an appreciable extent many of the acoustic and physical difficulties sometimes encountered, but this

would hear the solo disembodied from the accompaniment by the width of the proscenium.

The second position, namely, over the proscenium, will prove effective in most theatres, its success depending on a short sound duct being as near the screen as possible. Confused tonal results would be caused by a long and badly shaped sound duct, and the more delicate tones of the organ will fail to reach the rear of the auditorium beneath the circle if the outlet is high above the screen.

An organ under the stage is suitable for a short, wide theatre. Sound will appear to come from the screen, but care must be taken to provide ample sound openings and sufficient height, otherwise the organ will be "bottled," and a poor crescendo result. The sound openings, however, must be suitably placed, otherwise the organist sitting in the centre of the orchestral enclosure, in the full stream of sound, is apt to misjudge the volume.

**Most Satisfactory Position**

An organ placed on one side of the proscenium is considered the most satisfactory position, particularly if the grille is kept at a moderate elevation, so that the sound can easily travel under the circle. Two organ chambers arranged one above the other are much to be preferred. With this arrangement a narrow grille, which usually assists the general decorative scheme, can be used with success. The theatre organ is essentially a product of

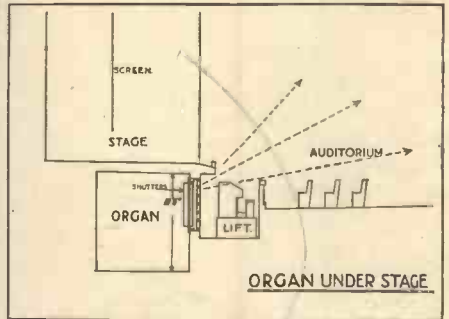

An organ fitted under a stage.

any organ the question of position must be considered. The finest and most complete organ can be ruined by accommodating it in the wrong place. The organ "voicer" can, however, overcome to an appreciable extent many of the acoustic and physical difficulties sometimes encountered, but this

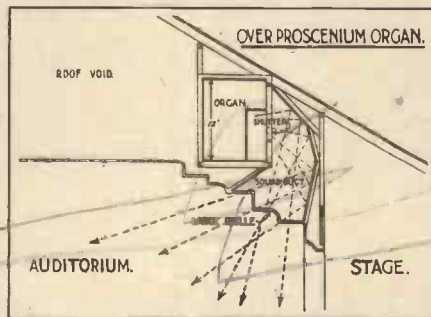

An organ fitted over a proscenium.

modern times, but without the use of all the fundamental principles of organ-building science, no organ, whatever purpose it may be required to serve, can be successful or reliable. In the Christie organ these principles are applied and maintained. Whether it be in the selection of timber, the making of pipes, the manufacture of the electro-pneumatic action or in voicing and finishing, these essential principles are rigidly observed.

The Christie Unit Organ, which is the subject of this article, is manufactured by Wm. Hill & Son and Norman & Beard, Ltd., to whom we are indebted for the above information and illustrations.

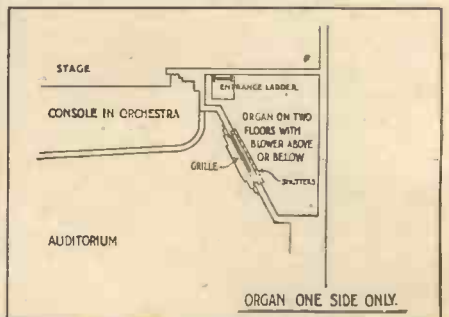

An organ fitted on one side of a proscenium only.

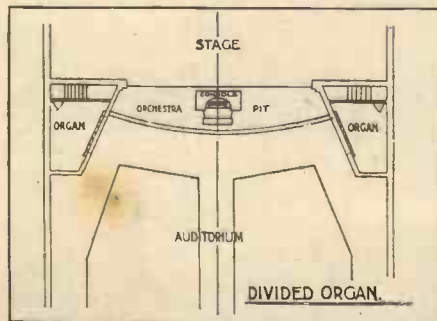

The layout of a divided organ.

can rarely be done without sacrificing some of the delicacy and purity of tone. The line sketches on this page show the four most likely positions for organ chambers, namely: divided, one on each side of the proscenium; over the proscenium; under the stage; and one side of the proscenium.

**A Divided Organ**

Taking the four positions in the order mentioned above, the first is suitable for a large organ of say from 10 to 15 units upwards, that is if there is not too great a distance between the organ chamber. A small organ of 9 units or under would prove very unsatisfactory, however, because if the building is narrow and the sound openings are placed close to the screen, the listener

# GUIDING AIRCRAFT BY WIRELESS BEAMS

Interesting Details of a System of Short-Wave "Beam" Radiation which is used for the guidance of aircraft, thus enabling the pilot to make a "blind" landing at the right spot and at the correct landing angle



By means of two lighthouses similar to the one shown, emitting "light waves," it is possible to acquaint the pilots of aeroplanes of dangerous atmospheric areas and to point out the safest route to follow.

ONE of the riskiest jobs the pilot of an aeroplane has to face is that of landing his machine in foggy weather, when the usual landmarks and signal lights at the aerodrome are completely obscured. Various ingenious schemes have been designed to assist him in these circumstances, including the use of buried cables fed with alternating current and laid around the outside of the landing field. This "leader gear" radiates a sort of wireless "shadow" of the landing field into the upper air, so that the pilot can tell when he is above it.

In America, particularly, they have recently developed a system of short-wave "beam" radiation, which enables a pilot to make a "blind" landing with absolute confidence that he will reach the ground at the right spot, and at the correct landing angle. In addition, a clear-cut radio track or "guideway" is provided from beginning to end of the whole flying course, and it may be as well to explain briefly how this is done before describing the "terminal" wireless aids used when actually landing at the end of the journey.

### Guiding Beams

The long-distance beams which mark out the main route are shown in Fig. 1. Two separate transmitting aerials A, N are

"swinging" the beam from a single aerial to and fro, through a small horizontal angle. In either case the beam on one side is constantly modulated by the Morse letter A, which consists of a dot followed by a dash (.-), whilst the other beam is

similarly modulated by the Morse letter N, which consists of a dash followed by a dot (-.).

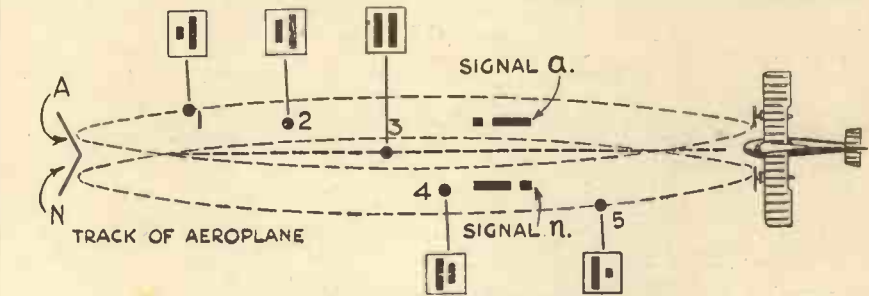

Fig. 1.—A plan of a long-range guideway.

Along the centre line of overlap these two signals "merge" into a continuous

note, which tells the pilot that he is on his proper course. Should he stray to one side or other of this central path, the continuous note breaks up into the characteristic "a" or "n" signal, and so auto-

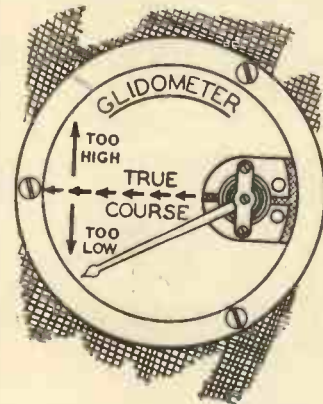

Fig. 3.—The dial of a glidometer.

two vertical lines which remain of equal size so long as the aeroplane flies along the centre line, as shown at 3, Fig. 1. Should the machine deviate to the right or left, one line immediately shrinks in size and becomes shorter than the other, as shown at 1, 2 and at 4, 5.

### Nearing His Destination

As he nears his destination, the pilot runs into a new set of beams radiated locally from the aerodrome. These are shown in elevation in the upper part of Fig. 2, and in plan in the lower part of the sketch. First of all there are two "run-away-indicating" transmitters, each having a limited field of action. They radiate two overlapping fields, as clearly shown in the plan at C, C1, and also carry modulating signals (such as the Morse letters A and N), which give the pilot a very clear-cut indication of his direction as he approaches the landing field. The long-distance beams having now finished their useful purpose, the pilot switches over to his short-wave receiver, which marks the "middle path" between the two overlapping fields C, C1 in the same way as before. Simultaneously, he picks up signals from a horizontally polarized "landing beam" marked B, in the upper part of the diagram. This is radiated on a 3-metre wavelength, modulated with a 60-cycle note.

As the landing beam plays a very important part in the subsequent proceedings, it is shown separately in Fig. 4. The beam is radiated upwards at a definite angle to the horizontal, as shown, and the pilot flies down it along what is called "the line of constant field intensity."

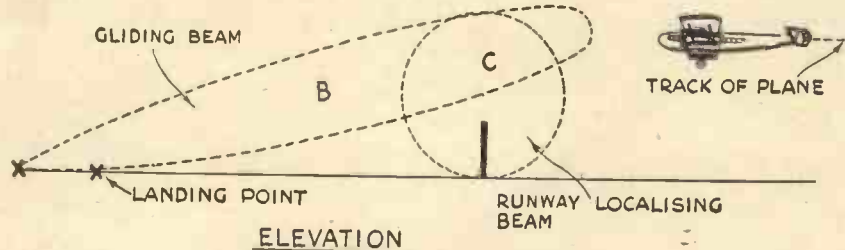

### ELEVATION

Fig. 2.—Showing the guiding and localising beams of an aeroplane.

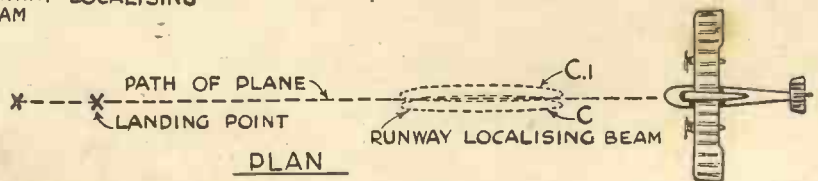

### PLAN

used, set at a slight angle to each other so that the beams overlap along the central line. Or the same effect is secured by

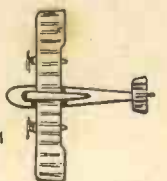

### Obtaining a Correct Gliding Angle

The instrument board on the aeroplane is fitted with a "glidometer" (Fig. 3), which measures the strength of signal pick-up. All the pilot has to do is to steer a downward course such that the needle keeps pointing to the centre of the scale. If the needle goes above or below this centre "zero," the pilot knows that he is flying "too high" or "too low," and corrects accordingly.

One naturally asks why flying along a line of constant field intensity, indicated by the centre or zero point on the glidometer, should automatically bring the machine safely to ground at the correct landing angle. To a certain extent, this is governed by the power radiated from the 3-metre aerial, as well as by the previous calibration of the "glidometer" indicator. But it is based primarily upon the properties of the beam itself.

From Fig. 4 it will be seen that the whole of the radiated energy is concentrated within a club-shaped area. This, of course, is due to the directional type of aerial used. Now at any given distance from the aerial the maximum signal strength will be found along the centre line of the club-shaped beam. But if the aviator came to ground along this centre line, the glidometer needle would not remain at a steady reading throughout, because, as the machine flies closer to the transmitting aerial, it is bound to pick up more signal energy, so

that the needle would show a constantly increasing deflection. Also it is clear from the diagram that flying along the centre line of the beam would bring the machine down at far too steep an angle to make a safe landing.

### "Constant Field Strength"

In order to follow the dotted-line path

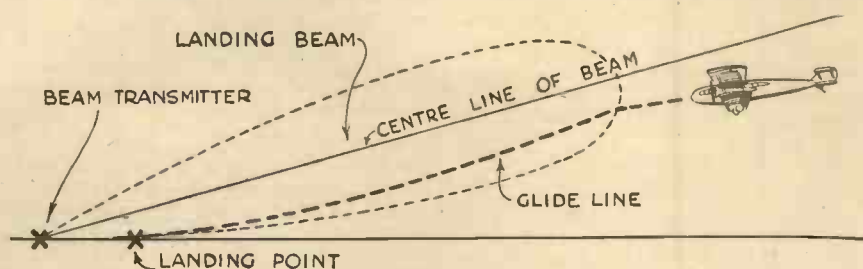

Fig. 4.—A short-wave "gliding" beam.

of "constant field strength," the machine, as it approaches the transmitting aerial (which is located some distance behind the actual landing point), gradually edges farther away from the centre line of maximum field strength, and gets closer to the outside margin of the club-shaped field. In other words, the normal increase in signal pick-up as one approaches the transmitter is "off-set" by curving outwards towards

the outside edge of the beam, where the field is naturally weakest. So that by keeping the pick-up indicator at a steady deflection the machine is automatically guided along a curve which brings it to ground gradually, and at a safe landing angle.

It should be mentioned that the aeroplane is fitted with two separate aerials. The first, used for receiving the long-

distance "routing" signals, consists of a wire mounted vertically behind the cockpit with a horizontal top, which extends back towards the rudder-fin so as to give the aerial a directional effect.

The second, which is used for picking up local beam transmissions from the aerodrome, consists of a short horizontal "di-pole" mounted parallel with the leading edge of the wings.

**M**EETING ocean-liner passengers at Cherbourg and flying them to London. Taking engineers on urgent survey flights along the Persian Gulf. Carrying film producers and their equipment to shoot special scenes in Palestine. Rushing business men to urgent conferences and appointments in this country and abroad. Dashing with trainers and jockeys to race-meetings on the Continent, and flying newly-married couples on aerial honeymoons. Those are just a few of the flights which have been undertaken quite recently, and accomplished with swift success, by the Special-Charter Department of Imperial Airways.

To glance through a list of some of the latest special-charter trips with one of the experts of this department is to realise the vital part which taxiplanes now play in saving that time which is money to so many people who are busy with urgent and important affairs. Take, just as an example, the case of a liner arriving at Cherbourg early in the morning. After this Cherbourg call it steams over to Southampton, arriving there say at about two o'clock the same day; after which the boat-train brings passengers up to London, which they reach probably about five o'clock. But if they send a taxiplane over to Cherbourg the night before, then a passenger can leave the liner directly it reaches Cherbourg, board this waiting aeroplane, and fly from Cherbourg to Croydon in about an hour and a half, a car taking him up to his hotel in the West End in time for breakfast. In this way, therefore, by chartering an air special to meet them at Cherbourg, it is possible for busy men to save an entire day.

Then there was the case, just lately, of an American student who was on his way to this country to sit for a special examination at Cambridge. Instead of putting into Plymouth, as it had been expected to do, the liner in which he was travelling went on to Cherbourg. This meant that, had he relied on ordinary transport, the student would have reached Cambridge just too late for his examination. He wirelessed to Imperial Airways, however, and

## THE VOGUE OF THE TAXIPLANE

an air-taxi solved his problem without any difficulty.

The other day—to take another example of what specially-chartered aeroplanes can accomplish—they had a party of engineers who wanted to do some rapid survey work at various points down the Persian Gulf. One of the machines picked them up from a liner at Alexandria; and in not more than a few days, by air, they covered distances which, by slow and difficult surface transport, would have taken them weeks, or probably months.

### Time Saved

More and more people nowadays are beginning to realise the immense amount of time they can save, when on long and urgent journeys, if they charter an aeroplane rather than travel by boat, train or car. Not long ago Imperial Airways were consulted by a film producer who found that he needed to take a number of important shots at various places out in Palestine. They arranged for him to have a saloon-plane which was big enough to accommodate not only himself and his personal assistant, but also a complete unit of camera-men and their equipment. In this machine they all flew out to Palestine, making rapid trips from place to place, and taking films from the air as well as from the ground. They were, in fact, able to secure in a week or so, and bring back with them by air to London, material which they reckoned it would have taken them months to procure if they had not had the assistance of the aeroplane.

### Odd Predicaments

Odd, sometimes, are the predicaments from which they are called upon to extricate people. The other day they had the case of a big-game hunter who, after he had left England on one of his expeditions, found

he had left behind an essential part of his equipment. This was picked up for him and flown across to Marseilles, where it arrived just in time to reach him before his liner left that port.

At an early hour the other morning a 'phone call came through from a London hotel. It was from a business man who said he wanted to get up to Glasgow just as soon as he possibly could for some urgent interviews and conferences. An air-taxi stood waiting for him by the time he got down to Croydon, and he was flown to Glasgow in time for him to lunch with some of his business friends, and then to go on to his interviews and conferences afterwards.

To professional men the speed of the aeroplane is becoming increasingly valuable. Here, for example, from a recent list of flights, is the case of a number of experts who found it necessary, at short notice, to go from London to Liverpool to inspect a new engineering process. They were all busy folk. The time-factor was extremely important to them. So they chartered a big saloon-plane, in which they lunched while flying to Liverpool. Then they made a rapid inspection of the plant they had come to see. After which they dined in the air on their return to London, being back in town again with a minimum of disturbance of their ordinary routine.

Another rather similar instance was that of the director of certain Anglo-American interests who had dashed over from New York to London, and who could only stay in this country for about a week. During this brief trip he wished to inspect the equipment at a number of factories in different parts of the country. Chartering a fast taxiplane, he did all he wanted to do in a couple of days—which left him time for certain important conferences in London before he hurried back again to New York.

Apart from such business trips, many other uses are now found for specially-chartered aircraft. Surgeons and doctors fly to urgent cases. Invalids are carried in machines equipped specially for their comfort.



# ABOUT GRAMOPHONE RECORDS

*Why does the quality of reproduction fall off towards the end of a record? This question is interesting to all who like to know something about the technical features of gramophones.*

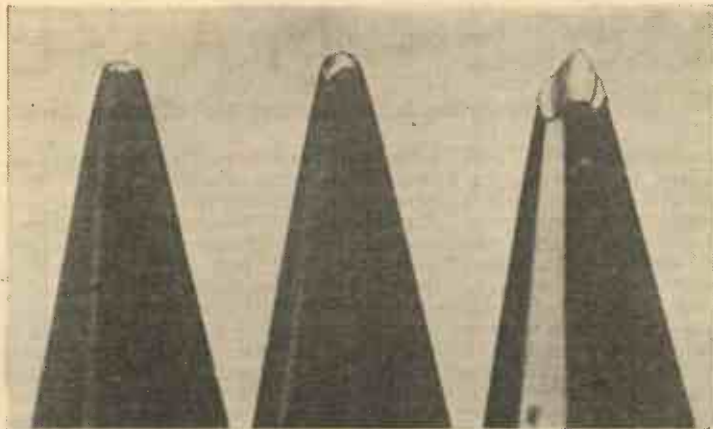

Fig. 2.—A photomicrograph showing (left) an unused loud-tone needle. (Centre) After playing one side of a 10-in. record, and (right) after playing eight sides. Note the bad wear, causing a hump and sharp edges.

THE generally accepted explanation of poor quality is that the point of the needle wears and does not follow the variations in the sound track as it should; but while this assumption is correct up to a point, it is only a half truth. The needle fails to follow the track not so much because it is worn, but because of an inherent difficulty in the recording process.

Sound, musical or otherwise, is produced by vibration of the air; the faster the vibration the higher the note, or *vice versa*. A record plays by reason of the fact that it vibrates a needle-point at various speeds ranging from about 50 to 4,000 times per second. Actually it goes a little lower and a little higher than this, but not very efficiently. If a record is examined with a lens or low-power microscope, it will be

seen that the needle travels and the distance between the wave-crests for any given note. It will also show that as the pitch or frequency of the note increases, the distance between

### DO YOU KNOW THAT—

The circumference of the outside grooves of an average 10 in. record is approximately 29 in. ?

A record plays by reason of the fact that it vibrates a needle-point at various speeds ranging from about 50 to 4,000 times per second. ?

the wave-crests decreases, for it is obvious that to get 3,000 waves into the same length of groove as 50 waves, the former must be very much closer together. But this is not all, for it shows that as the needle gets towards the centre of a record the wave-crest separation becomes smaller and smaller for every note, and it is this cramping which is the main cause of falling-off in the quality of reproduction.

### Wave-crest Separation

The circumference of the outside grooves of an average 10-in. record is approximately 29 in., and the turntable speed 80 revs. per minute (approximately 1.3 revs. per second). This means that the needle has a speed of  $29 \text{ in.} \div 8.7 \text{ in.} = 3.3 \text{ in. per second}$ . To produce a 50-cycle note we have seen that the needle must pass through fifty wave-crests in a second, and as it travels 3.3 in. in this time it follows that the wave separation is  $3.3 \div 50 = .066 \text{ in.}$

When we come to the end of a record, however, it is a different story, for here the circumference may be only 11 in. This means that at 80 revs. per minute the needle only travels 14.3 in. per second, so that the wave-crest separation is now  $14.3 \text{ in.} \div 50 = .286 \text{ in.}$ , as against .754 in. on the outside—in other words, the waves have become cramped together. This cramping does little harm on such a low note as 50 cycles, for the needle-point can easily follow these comparatively large waves, but it is a very different matter with the high notes.

### High-note Loss

Calculating in the same way, it will be found that in the outside grooves the wave-crest separation for a 3,000-cycle note is

approximately  $.0128 \text{ in.}$ , or  $\frac{1}{78} \text{ in.}$  Small as this is, the needle-point will follow it fairly well, and it is not until the inside grooves are reached that trouble arises. Here, owing to the smaller circumference, the wave-crest separation of a 3,000-cycle note may be only  $.0048 \text{ in.}$ , or roughly  $\frac{1}{208} \text{ in.}$ , which is scarcely as large as the needle-point itself. The consequence is that it simply passes through these grooves without vibrating at all, or if it does, only in a feeble and distorted manner. It is due to this difference between the outside and inside grooves, that if the recording is less than usual, the blank part of the record is always on the inside.

It is clear, then, that the chief reason for the falling-off in quality is due to the fact that the needle cannot follow the cramped wave-form; it is only exaggerated, but not caused, by wear of the needle point. This does not mean that needle wear is unimportant, for a much-used point will make a bad start and a worse finish on any record. Imagine the badly worn point shown in the photomicrograph ploughing its way through the grooves of a new record.

Incidentally, the above figures show very conclusively the importance of correct turntable speed. If the disc is recorded at 80 revs. per minute, then it is only at this speed that it will give a true rendering of the original sound. Suppose the speed is increased 20 per cent. to 96 revs. per minute (a fault often found owing to wear of the speed regulator), then it is clear that the whole range of frequencies will increase 20 per cent. What should be a 50-cycle note will become 60 cycles, and 3,000 cycles will be 3,600 cycles.

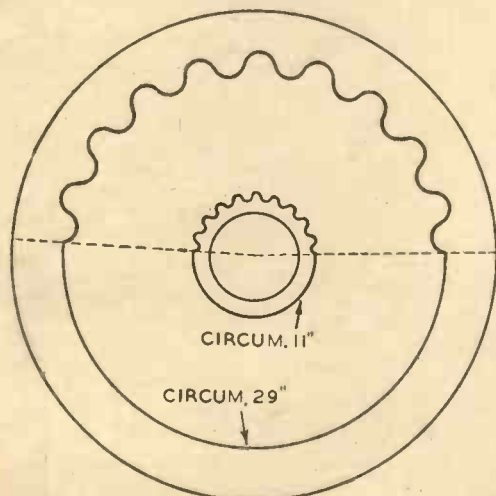

Fig. 1.—Showing the waviness of the grooves, greatly exaggerated, for a 50-cycle note. It will be seen that the distance between the wave-crests becomes much smaller at the end of a record, owing to the smaller circumference. With high notes this cramping prevents the needle from following the sound-track as it should.

seen that the first two or three grooves are quite plain and smooth, but a little farther on they begin to look wavy and irregular. Fig. 1 is a diagram of a record showing the waviness of the grooves greatly exaggerated, and it is easy to see that if a needle-point is drawn quickly through that wavy line, it will be thrown from side to side as it passes along the humps or "wave-crests."

To produce a low note of, say, 50 cycles, we know that the needle must vibrate 50 times per second, or, in other words, it must pass through fifty wave-crests in a



Fig. 3.—A steady 250-cycle note. The waviness of the grooves, which have been filled with chalk, is easily seen.

# HOME - MADE

Some simple, economical and effective alarms

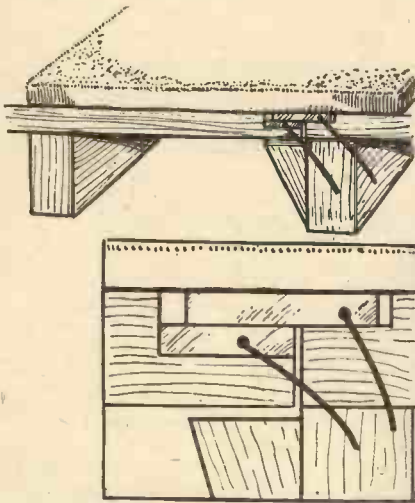

Fig. 7.—Suitable and effective contacts that can be arranged under the mat.

ONE often hears the subject of burglar alarms discussed in terms of mystery. Actually, they are nearly as simple as the household bell system.

There is one decision to make. Shall the burglar alarm be obvious, so that its presence or notification scares off intending intruders (which might also have the effect of drawing attention to valuables), or shall it be hidden and the householder himself rely on the effectiveness of the system? If you intend to take the first alternative, fix the alarm bell in such a position outside the house that no one, not even at night, can fail to see it, but at the same time make absolutely certain that it cannot be reached and thus give anyone the opportunity to prevent it ringing. The alarm bell should, however, be the only thing which is noticeable, all other devices, wires, etc., being well hidden or protected to prevent tampering.

### A Simple System

The simplest system is one in which movements of a door or window cause con-

tacts to close, thus completing the circuit and ringing a bell. There is, however, one serious disadvantage in this system, for it is only necessary to cut or break the wires to stop the bell from operating. Should the intruder notice wires and contacts attached to a window it would be quite a simple matter for him to take a piece of glass out and then cut the wire, so that the window could be fully opened without operating the alarms. The next best system, and one which will be advised for ordinary conditions, is an arrangement of contacts in series with each other, continuously closed, and in which the alarms only operate once the circuit is broken. Immediately this happens the alarm bell rings, and even if the series circuit is made again the bell will still keep on ringing until such time as it is purposely and deliberately stopped. A third system, which works on the Wheatstone Bridge principle, is generally considered the most effective, even against the "technical crack." This system is "set" with the resistance of the alarm circuit balanced against that of an adjustable "arm" and any alteration in the resistance of the alarm

taken from an electric bell and mounted firmly into the top of a wooden box. The faces of the cores are covered with a thin disc of paper, "B" to make sure that the armature "C" will come "unstuck" when current in "A" fails. The armature is riveted to the brass arm "D," which is pivoted at "E." This pivot should be quite free and must allow the arm to fall easily into the two contacts "F" and "F<sub>1</sub>," which are made of thin but very springy brass. "G" is a standard 400-ohm potentiometer used for radio purposes. Beyond these details little more need be said, except that a cover should be spread over the top of the box, which then leaves only the re-setting knot "H" and the resistance to be seen. The box should be

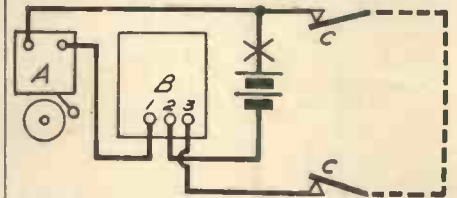

Fig. 1.—The theoretical circuit of the series-relay system.

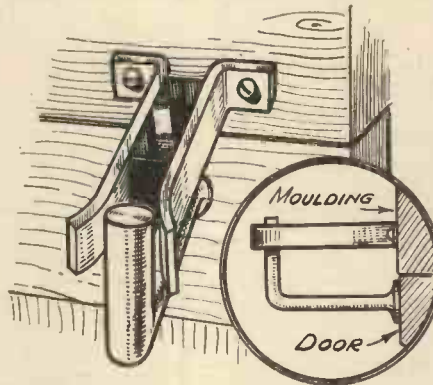

Fig. 3 & 4.—The type of contact which covers most positions where the door moulding juts out over the door; an ordinary cupboard hook provides a satisfactory key, and is shown in operation above.

circuit is sufficient to operate the system. If the intruder cuts the wire or tries to be clever and short circuits the contacts, which he hopes later to separate safely, the balance is upset, and as these systems are generally balanced very closely, no method can be devised which gives any hope of keeping the system balanced for even the shortest space of time. However, this system requires continual attention and is not advised for ordinary household work.

### A Series-Relay System

Fig. 1 shows the main details of the series relay system which is advised. "A" is the alarm bell, "B" the mechanically re-set relay, and "C," "C" the contacts arranged in series throughout the house. The bell is just the ordinary electric bell which can be obtained quite cheaply. If it is intended to put the bell outside the house then a more expensive waterproof type should be used. The relay, shown in detail in Fig. 2, can be purchased, but without the variable resistance, which is included purely to reduce the amount of current passing to the most economical value. "A" is a pair of coils

fixed in a place as remote as possible from any point where an entry might be made, probably an upstairs room is best of all. The alarm bell, too, should be fitted in such a position where it can be easily heard both inside and outside the house, but out of the way of possible interference. When the rest of the system has been completed and all contacts closed, lift the arm "H" against the pole pieces and adjust the knob of the resistance so that the arm just holds up. Some allowance might be made for vibration dislodging the arm. Further economy in current can be effected by rewinding the coil bobbins with 36 or 38 S.W.G. D.S.C.

Usually two 1½-volt bell cells will be ample to operate the system nightly for many months. A switch should be inserted into the battery lead at "X" (Fig. 1), to render the gear inoperative when not required. In testing the system at night, when the ringing of the alarm bell might unnecessarily disturb others, an ordinary flash-lamp bulb can be inserted across the bell contacts and the bell disconnected whilst the tests are made.

### Effective Contacts

The contacts, described later, should be placed in every conceivable place where an entry might be effected. A little window which you might pass might be just the size to fit the intruder, and so every possible

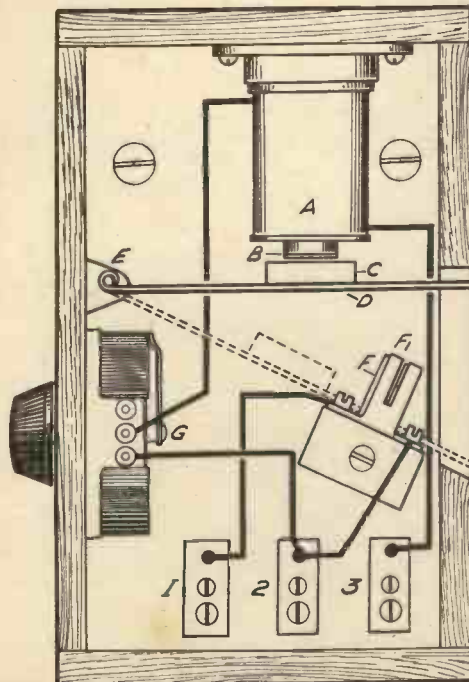
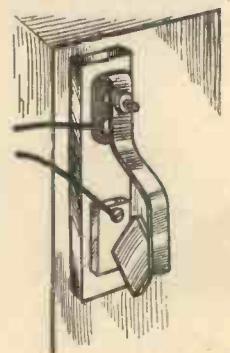

Fig. 2.—The relay shown can be purchased, but without the variable resistance, which is included to reduce the current passing to the most economical value.

Fig. 5.—Large windows which do not open, but provide an excellent opportunity for total removal as a means of ingress, can be safeguarded by a contact of the type shown here.



# BURGLAR ALARMS

which afford ample protection against burglars.

point should be covered, even roof traps and skylights and pantry windows. The various types of contacts which are required are very numerous, and only a few are described here. The main thing to avoid in these contacts is flexible wires or wires attached to moving parts which may be a cause of non-operation later. Fig. 3 shows the type of contact which covers most positions. One of the contacts has a piece of fibre or ebonite fixed to it, to prevent the contacts closing together, connection between the two parts only being made when the key-piece is inserted. The contacts are screwed to the top of the door or window

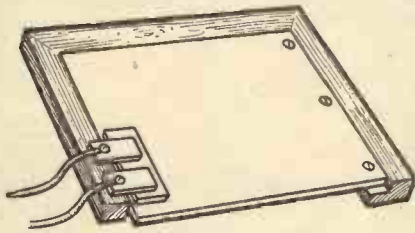

Fig. 8.—Another under-the-mat type of contact which is very effective.

surround and the key, which can be a stout brass screw with the head cut off, is driven into the door itself. The connecting wires are best soldered to the foot of the contacts. Where the door moulding juts out over the door an ordinary cupboard hook provides a satisfactory key and is shown in operation in Fig. 4. The coloured lacquer must be cleaned off the brass before such hooks are used, because it is an insulator. Contacts for metal windows must be mounted on ebonite blocks, which are then secured to the iron frames with metal thread screws, it being necessary to drill and tap in these cases. It might be found that the metal windows are insulated from one another in some cases, but it is always advisable to insulate the key piece as well. Large windows which do not open, but provide an excellent opportunity for total removal as a means of ingress, can be covered by a contact of the type illustrated in Fig. 5. The base should be a thin slip of ebonite and the upper contact of  $\frac{1}{4}$ -in. strip brass. The lower contact is of thin springy brass and just sufficiently strong to hold the solid brass key up in position. The complete

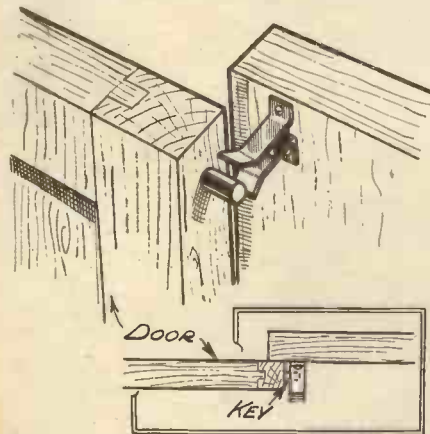

Fig. 11.—A pictorial sketch showing the contact suitable for the circuit shown in Fig. 10.

contact can be secured to the glass with sealing wax or Page's glue. The best position is in the centre of the window, but the device is effective even at the edges. The device operates by the inertia of the key. When vibration shakes the window, the device shakes with it, but the key tends to remain steady, and pushes the thin spring outwards, and relieves the pressure on the solid contact, with the result that the key drops out and breaks the circuit. Precautions and care in making and adjusting the thin spring must be taken to ensure that wind or traffic vibration will not cause the key to fall out.

Where a window or a skylight can be barred  $\frac{1}{2}$ -in. split conduit can be used through each bar of which a thin insulated wire is passed, and connected, as shown in Fig. 6. Ordinary pipe saddles can be used to secure the bars. The effectiveness does not lie in the strength of the tube but in its weakness. No. 36 S.W.G. D.S.C. wire is suitable for use.

### "Under the Mat" Contacts

These can be arranged as shown in Figs. 7 and 8, the first being suitable in wooden floors, and the second on stone or tiled floors. Outside gates can also be contacted, a satisfactory form being shown in Fig. 9.

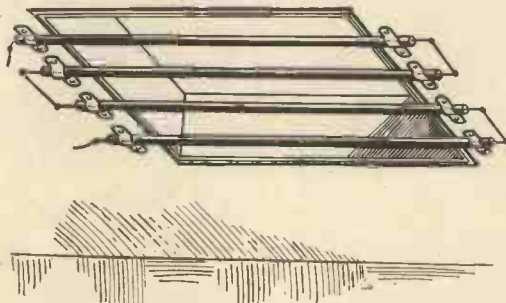

Fig. 6.—A suitable arrangement for safeguarding a skylight by means of a thin insulated wire passed through bars and connected as shown.

The two contact plates are screwed to the gate post and the key piece made from springy brass to the gate itself. Used in such a position the contacts are invisible and also protected from the weather. The wires are passed right through holes drilled in the gate post as shown in Fig. 9. All outside wires should be lead covered and hidden wherever possible, whilst those inside can be of 26 S.W.G. D.C.C. Fig. 10 shows the essentials of a piece of apparatus which is necessary under the following conditions. If a contact is fitted to the front door, the last person out will trip the main relay, merely in the act of opening the door to pass through, and it is impossible for the main relay to stay "up" if the door is left open. To overcome this a special out relay is required which makes the door contacts inoperative until they are closed. "A," in Fig. 10 represents the door contacts which must be open before the system can be "set." The lever "B" is then raised so that the armature "C" is against the core of the magnet "D." The point of the trigger "E" will keep it in position mechanically until such time as the main relay (Fig. 2) is closed. When this happens the coil "F" attracts the armature "C" and releases the trigger "E," which, however, does not fall owing to the line current

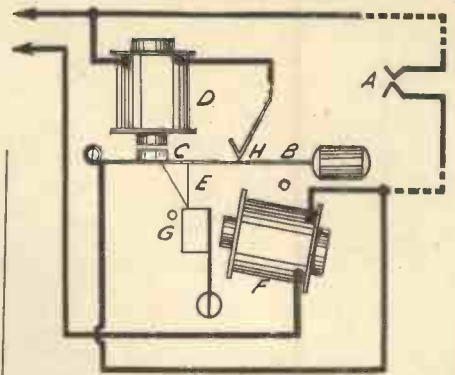

Fig. 10.—A circuit diagram of a special out relay which makes the door contacts inoperative until they are closed.

traversing the coil "D." However, when the door is shut and the contacts "A" close, the coil "D" is short circuited and the armature "C" drops clear, the armature "G" still being held against "F," and the contact "H" broken. This leaves the door contacts "A" in charge, and should these be opened then the alarm bell will ring in the normal way.

### Commercial Burglar Alarm

Readers may also be interested to know that there are a considerable number of burglar alarms obtainable on the market for quite a small outlay. These alarms take various forms and are generally of the make-and-break contact type. Of these, that known as the "Vesta," consisting of a divided sphere, one half of which acts as a bell and the other half containing the mechanism, is a typical example. The half containing the mechanism is also fitted with three legs, and when wound up by twisting the two halves in opposite directions, is placed on the floor legs downwards. The weight of the device causes the legs to recede into the body and acts as a check. When placed behind a door, window, etc., opening them will cause the ball to roll, thus freeing the legs and causing the bell to ring for several minutes.

Door contacts suitable for operating burglar alarms can also be obtained very cheaply and consists of continuous and trigger types. As a further safeguard against burglars, it is also possible to obtain special locking devices for locks which make them practically burglar-proof.

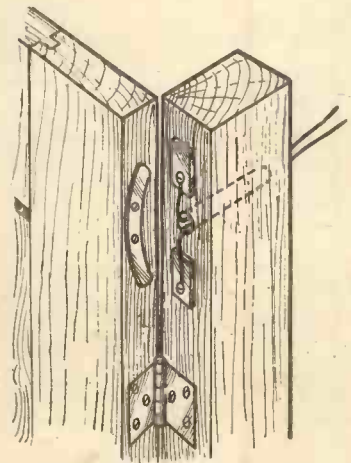

Fig. 9.—A satisfactory method of fitting contacts to an outside gate.

# THE AMPLION RADIOLUX SUPERHET

A FIVE-VALVE ALL-ELECTRIC SUPERHET TABLE MODEL



A three-quarter front view of the Amplion receiver, showing the simple knob layout and the attractive appearance of the cabinet.

**T**HE Amplion A.C. Radiolux Superhet Receiver which incorporates every modern device, the latest valves, knife-edge selectivity, a minimum number of controls, and is moderately priced, is definitely an ideal set for even the most fastidious of wireless enthusiasts. One of the many interesting features is the neon tuning device which is fitted above the tuning scale, which indicates when a station is correctly tuned in. This is achieved when the length of glow in the neon lamp is fully extended. The wave-change switch knob is situated on the right-hand side of the receiver, and the wave bands covered are 200 to 550 metres on the "medium waves" and 900 to 2,000 metres on the "long waves."

#### On-off Switch and Volume Control

The knob on the left operates the on-off switch and volume control, and when connected to the mains the set is switched on by slightly turning this knob in a clockwise direction. Thirty seconds after switching on, the set becomes sensitive, and the volume can then be controlled by continuing the tuning movement of the knob. No difficulty should be found when tuning in any desired station as the illuminated scale has been accurately calibrated in wave-

lengths. Thus, with the wave-change switch in the "medium wave" position, London Regional (342.1 metres) will require a setting just before the 350 engraving on the dial. Many stations will be heard during this tuning process, and by noting the wavelengths as indicated on the scale and referring to published programmes, they should be easily identified.

#### The Circuit

This is of an entirely new design, comprising eight tuned stages. The new H.F. pentode is coupled to an octode frequency changer, which is in turn I.F. transformer coupled to the second H.F. pentode

the receiver. The intermediate transformer is fitted with a small pre-set condenser, to enable it to be carefully tuned to give optimum load and thus obtaining maximum efficiency. An aerial trimming knob is situated at the rear of the receiver chassis and is used for accurate adjustment of the aerial in use. The set is fitted with pick-up terminals and provision is made for connecting an extra loud speaker. The internal speaker may be easily disconnected if so desired, thus enabling the speakers to be worked separately.

#### Testing Out

On test a considerable number of stations were heard on both long and medium waves at good loud-speaker strength. The selectivity was exceedingly good, there being little under 9 kilocycles separation and second channel whistles were entirely absent. On rotating the tuning knob it was found that background noises were very loud between stations, thus showing the high amplification of which the set is capable, but immediately a signal was tuned in the background disappeared, leaving the signals clear and interference free.



Showing the neat and compact chassis layout of the Amplion superhet.

detector, this being R.C. coupled to the pentode output stage. The high frequency variable- $\mu$  pentode controls signals of all strengths without any trace of distortion, and makes the receiver particularly suitable for districts near high-power stations (Droitwich being a typical example). The latest type of octode frequency changer has been employed in the second stage, being coupled to the second detector by a high efficiency I.F. transformer. The second detector circuit which has usually proved difficult to balance has been specially designed, and the unique method employed ensures a pure signal being delivered to the output stage. A recent development in pentode valve design is incorporated in the output stage and allows for an undistorted output of 3 watts. Volume control is effected by controlling the first stage gain by use of a potentiometer which incorporates the mains on-off switch.

#### Other Features

The set is enclosed in a fine walnut cabinet of the conventional table type, which has been designed to prevent boom and box resonance. The Amplion speaker is fitted above

AN IDEAL BOOK FOR THE  
BEGINNER

EVERYMAN'S  
WIRELESS BOOK

5/- or 5/6 by post

From GEORGE NEWNES LTD.,  
8-11 Southampton Street, Strand, W.C.2

#### SPECIFICATION IN BRIEF

RECEIVER: Amplion Radiolux 5-valve superhet. A.C. table model.

MAKERS: Amplion (1932) Ltd.

SPECIFICATION: Five valves. Variable- $\mu$  high frequency pentode, octode frequency changer, intermediate amplifier, high frequency pentode detector, with power pentode output, and an indirectly full-wave rectifying valve. Energised moving coil speaker. Automatic volume control. Cellulose steel chassis. Illuminated full vision scale. Neon light visual tuning. Attractive walnut cabinet, 19 x 15 x 12 in. deep.

PRICE: 12 guineas. A.C. mains 110 or 190/265 volts, 40/100 cycles.



A rear view of the Amplion superhet showing the aerial trimmer knob on the left of the chassis.

# HOW MAPS ARE MADE

*Maps were never so much in demand nor so widely appreciated as they are to-day, but the making of a map is so largely a specialist's work that it still remains something of a mystery to a great number of people.*

## The Scale of the Map

Instances are the scale of the new map (which determines the size of printing sheet required), the colour

scheme to be adopted, affecting the number of printings, the style and number of place-names and of roads, whether the Ministry of Transport's "A" and "B" classified roads are to be shown in different colours or widths and their numbers given, and so on. Maps showing the height of land by contrasting colour-zones with the roads in still another colour may entail as many as nine separate "runs" through the printing machines, adding, of course, very appreciably to the cost. These important points settled, and also the "method" of production decided on, the necessary instructions are passed on to the geographical draughtsmen—trained craftsmen who put the actual work in hand. Firstly, the necessary lines of latitude and longitude may have to be laid down as a framework for the detail, such as the coastline, place-names, roads and (if required) rivers, railways and contours for height, all of which will occupy a skilled draughtsman for weeks, or even months, according to scale and the amount of informa-

tion to be shown. Should this drawing be prepared for photographic reproduction, everything must be delineated with meticulous accuracy and finish. Occasionally the names are set in type, cut into small slips and pasted in position, but obviously this method has not the same flexibility and artistic effect as the "written

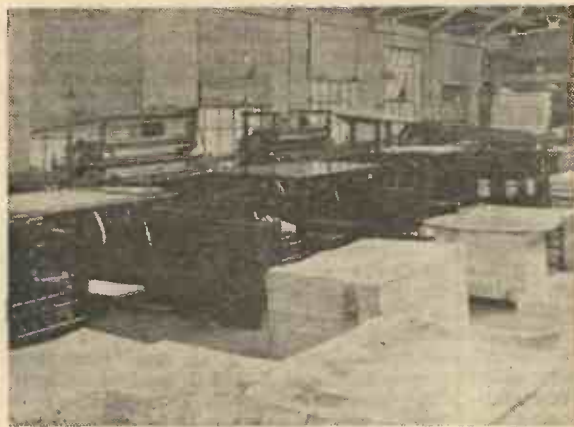

The printing department of Messrs. Geo. Phillips where thousands of copies of maps are produced.

THE earliest maps were, of course, efforts of almost pure imagination, but they showed how even in those far-off days there was already an urge for man to put on record the scanty knowledge he had of his surroundings, eked out by fanciful conceptions of what was beyond his ken. In mediæval times map-making was still almost a Monkish art, the same decorative embellishment being lavished upon a map as upon an illuminated missal, while the coat-of-arms of a generous patron or possibly an ambiguous elephant or dolphin served to fill spaces which might otherwise have been unsightly blanks. But with the spread of exploration in the Elizabethan era maps were called for and produced dealing with hard facts rather than fancy, and it is a combination of the accuracy made possible by our accumulated knowledge with the æsthetic beauty of colour and draughtsmanship at our disposal which renders a good map of to-day a thing both of utility and beauty.

To understand how the finished article is produced by a firm specialising in map-printing it will be necessary to visit first the editorial department whose functions are both selective and critical, and assuming, for example, that an entirely new road map of Great Britain is to be produced, many points must be settled editorially before the actual work is put in hand.



Another view of the geographical department.

word." In either case, the next process is for this original to be reproduced by photolithography upon the "plate" from which it will be printed.

## Engraved on Copper

Should it, however, be decided to have the map engraved on copper, or drawn by the lithographic draughtsman direct upon "stone" (this term still persists although aluminium plates have largely superseded lithographic stones), it is not necessary for the geographical draughtsman to make his original drawing in such finished style in regard to the names, but its accuracy in other respects must still be unimpeachable. For engraving upon copper, a method which for permanence combined with delicacy remains unexcelled, the drawing is passed to the engraver, who reproduces it upon a plate of that metal, from which transfers can be taken and "laid down" upon the aluminium printing plates.

Yet another method is known as wax-engraving, in which case the drawing is copied by incision upon a copper plate thinly coated with wax, type for the names being impressed down to the metal, which is afterwards "etched." The geographical



Geographical draughtsmen at work. These highly skilled men sometimes have to work many months compiling a single map.

draughtsman's work is, however, not yet completed, for as soon as a proof of the black "key" is available from the plate it has to be checked for imperfections, while he colours by hand a second proof to serve as a "colour copy" for the "tinters." Each colour requires a separate plate to itself (or "block" if printed "letterpress") drawn from an "offset" to fit the key, and of these there may be in the case of our "Road Map" as many as six or more. Printing is the art preservative of all the arts, and while this is a great distinction, it is at the same time an immense responsibility, for one mistake, if not detected in time, will be perpetuated on perhaps as many as a million copies, with dire results! Once the black "key" has been passed for press and the "machine plate" is ready in position, the mechanical side comes into play, printed sheets being thrown off at the

rate of 1,000 to 2,000 per hour by the latest types of rotary machines. When the required number have been run off, one of the "colour" plates is substituted for the black and the whole of the sheets run through again, and so on until each colour is printed.

#### Colour Register

Through all these stages, experience and the greatest care are necessary to ensure that good "register" is being obtained, meaning that each colour "fits" to the black "key" and one to the other. It has only to be remembered that as many as sixteen maps may be printed on one sheet and each in perhaps seven or eight different colours to realise that those in charge of the machines have themselves no light responsibility. Lack of space alone prevents one dealing with other activities which may

enter into the making of a map. The process department, for instance, in addition to dealing with the photo-lithographic reproduction of original drawings in line and half-tone, is responsible for the "etching" (eating away portions by acid) of blocks used for letterpress printing, while the transferring department, as its name suggests, is concerned with taking transfers from one plate to another, an essential and highly technical process.

But enough has been said perhaps to make it clear how intricate and varied are the processes of map-making, and to lend a little added interest to the next map which the reader consults. Robert Louis Stevenson wrote, "I am told there are people (although I find it hard to believe) that do not like maps." Perhaps if he had seen a modern map made he would have been still more scathing!

## INTERESTING MODELS

Recent additions to the hundreds of scale models made by the well-known firm of Bassett-Lowke Ltd., Northampton.



The first samples of the "Queen Mary" and the "Normandie," models of the two greatest ocean giants ever built, commencing their trials. These models are accurate in the main dimensions and are about 3 ft. long, being built to a scale of 1 mm. to 1,000 metres. Both models are electrically driven, but steam models are now in the course of construction.

Making waterline models of the famous French liner "Normandie." Here is one of the skilled craftsmen of Bassett-Lowke working out the fine detail necessary in these accurate 100 ft. to the inch waterline models of famous ships.

A Modern Engine Shed. Here is a fine new railway accessory, with saw-tooth-type roof which marks it out as a locomotive shed. The model is designed in model reinforced concrete finish, and the tower is an architectural feature and also a means of housing the lifting door, which in real practice would be of the roll-up type now used on the London Underground for car sheds, etc. Gauge "0" price 25s.

An entirely new range of tunnel entrances designed on modern lines has also been introduced by this firm. They indicate the widespread use of reinforced concrete in recent railway buildings. The tunnel mouths are made to suit both single and double tracks, and embody an interesting feature in the wing walls. These are made so that they can be placed at any angle to the track. The abutment, when used for a permanent model railway, can be arranged to suit the particular "formation of the country." In a temporary line the walls may be set so that the entrance stands up without support. It is suitable for a 0-gauge railway and is reasonably priced.

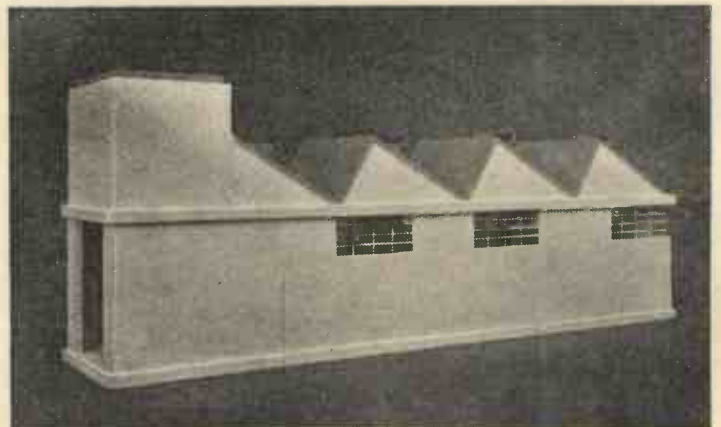



# Pearl Diving

The sight of a pearling fleet returning, the sails of some of them coloured orange by the light of fires burning on the decks, is one of the most picturesque in the world. This article gives some interesting facts concerning the pearl industry.

FOR many centuries the finest pearls in the world have been found in the Persian Gulf, where most of the population of the coast and the islands depend upon the pearl industry for their livelihood. Recently, owing to economic depression in Europe and America and the increased production of cultured pearls in Japan, this very ancient but little-known industry has been severely affected. Eight years ago the value of the pearls exported from the Bahrein Islands during one season was estimated at £2,000,000 sterling; during the last two or three years the value of the annual catch has fallen to less than one-fifth of this amount. About five years ago one pearl, of unrivalled size, shape, and colour, was sold in Bahrein for £15,000, but during 1932 and 1933 no single pearl was sold locally for more than £3,000.

Though cultured pearls were first introduced from Japan more than fifteen years ago, it is only during the last three years that they have flooded the markets of the West.

The centre of the diving industry and the chief market of the Gulf is the Bahrein archipelago, a little independent Arab State which is protected against external aggression by Great Britain, who has had treaty relations with the sheikhs of Bahrein for over a century. The present ruler is Sheikh Hamed ibn Isa Al Khalifah, a member of an ancient Arab family which came originally from the mainland of Arabia.

## The Fleet

Although the richest pearl banks are around Bahrein, the Sheikh receives no direct income from pearls. The revenue of his State is mainly derived from Customs duties upon imports. The value of the imports varies according to the success of the diving season, which lasts from the middle of May till the end of September, while the water is warm. On a day appointed by the Sheikh, which is announced by public proclamation, the pearling fleet, consisting of about 500 great sailing dhows, very like Roman galleys, sets out from Bahrein to the pearl banks, where they are joined by the fleets from the lesser Gulf ports. Until they clear the harbour the boats are propelled by heavy oars, each pulled by two men, who sing the song of the pearlmen as they row. Often the fleet returns at night when the moon and the tide are full. The sound of the oars chanting and the splash of the oars is carried across the still water to the town. The sight of hundreds of white sails, some of them coloured orange by the light of the fires burning on the decks, is one of the most picturesque in the world.

Mechanical apparatus of any kind is forbidden, and the methods of diving have not changed since they were described by fourteenth-century travellers. Each diver wears a clip like a clothes-peg to close his nostrils, leather sheaths protect his fingers and enable him to wrench the shells from

the rocks underneath the sea, and each of his big toes is guarded by a similar sheath. He descends on a rope which has a stone weight attached to it. This is hauled up when he reaches the bottom. Round his neck is slung a string bag, which he fills with shells, attached to a rope with which his comrade, the puller, draws him up again when he gives the signal. Divers remain below the surface for nearly a minute and a half, and they descend about thirty times in one day, often to a depth of 14 fathoms. The shells are heaped on deck during the day and opened in the evening under the vigilant eye of the captain, who puts away the pearls in his sea chest. No diver knows whether it is his shell that contained a pearl. While the men are working they take neither food nor drink, but they eat in the early

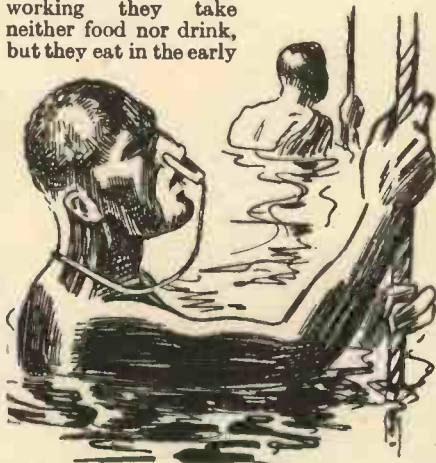

Each diver wears a clip like a clothes-peg to close his nostrils as shown.

morning and after sunset they have a meal of rice and dates and fish. The shells are thrown back into the sea, the divers believing that oysters feed upon the empty shells. They believe, too, that pearls are formed by drops of rain which are caught by the oysters at night.

The work is very strenuous and conditions are hard, but the divers on the whole are healthy and many of them show unusually fine muscular development. The Arab, by nature improvident and thinking nothing of the future, has an ingrained instinct for gambling, and there is always the chance of belonging to a boat which finds a really big pearl. These characteristics and the lack of other occupation have always been sufficient inducement to make Arabs become divers in spite of the hardships of the work.

## A Share of the Profits

The men are paid no wages, but they receive a share in the profits of the season. Divers are entitled to twice the amount which is paid to a puller, as their work is more arduous. There are several different

diving systems, and all of them are very ancient. Usually the captain of the boat borrows money from a merchant on shore to equip and provision his boat and to pay the two annual advances made to the divers at the beginning of the season and halfway through the off season. At the end of the season the pearls are sold, the expenses of the expedition are deducted, the captain takes one-fifth of the profit, and the remainder is divided among the divers and the pullers. But the shore merchant charges interest on the money which he lent to the captain, and the divers pay interest on the money advanced to them by the captain. Frequently the captain himself finances the boat, charging no interest, but in return for this he receives the share of five divers and has the right to purchase the pearls himself at 20 per cent. less than the current market price. In this system, which has increased lately, there are no outstanding debts against the divers. According to the strict letter of the Moslem law the taking of interest is forbidden, but many merchants who deal mostly in rice, not in cash, avoid the stigma of taking interest by agreeing to hand over 100 bags of rice on condition that the borrower returns 120 bags of rice at the end of the season. In this way consciences are satisfied.

The general principle of the diving system is a fair one, when strictly adhered to, but for some time serious abuses crept into it. In 1923 Sheikh Hamed, who was then the Heir Apparent, became Deputy Ruler in place of his aged father, who died two years ago, after a reign of sixty years. With the active support of the British Government he immediately turned his attention to the diving industry, and in a short time he succeeded in carrying out drastic reforms throughout the system. Since then he has never relaxed his efforts to maintain the improved conditions by severely punishing in his courts any infringement of the diving rules which he laid down. He reduced the interest on money advanced to a reasonable rate and restricted the amount of the advances. He instituted a simple system of diving accounts, and now every diver is compelled to keep a little book, which shows his debt to his captain. A staff of clerks are employed by the Government to check these accounts every season, and to report any inaccuracies. A certain percentage of the crew, chosen by the men of each boat, must witness the sale of the pearls by the captain, in order to satisfy themselves that they receive their proper share of the profits, and when a diver dies his diving debt dies with him and his children do not become liable for its payment.

## Buying and Selling Pearls

The diving rules and the system of accounts now form part of the curriculum of the Government schools, and the new generation of divers is learning to protect

(Continued on page 190.)

## LATHE WORK FOR AMATEURS

BUILDING A 15 c.c.  
PETROL ENGINE

Fig. 4.—Make certain that the tapping is square with the face by the method shown.

**B**EFORE cutting the ports in the cylinder liner it is as well to machine the cylinder head casting and also carry out certain drilling on the body of the engine. If the sequence of operations is maintained in the order stated, the construction will become simplified, and after the head and the drilling is completed, parts Nos. 1, 2, 3, 4 and 6 are ready for assembly.

## Machining the Cylinder Head Casting

The aluminium casting for the cylinder head, part No. 4, is cast with a chucking boss on the top and a clamping lug at either side. These lugs may be ignored, as also may be the chucking boss. It is intended to hold the casting by this boss to turn the fins and face the front, afterwards facing the boss and drilling and tapping the sparking plug hole. A more rigid fixing will result by proceeding in the following manner: chuck the casting and face down the boss level with the tops of the fins, bringing the tops of the fins level with a light cut, as illustrated in Fig. 1. Centre-drill and drill a hole right through with an 11 mm. drill. Failing one of this size, use one of  $\frac{3}{16}$ -in. diameter, which, although a few thousandths small, will not materially affect the tapping (see Figs. 2 and 3).

Next tap the hole with a 12-mm. diameter  $\times$  1.25 mm. pitch tap. Make certain that the tapping is square with the face by bringing the tail centre up to the centre hole in the tap, holding the squared end with a spanner resting on the tool slide as in Fig. 4. Run the lathe slowly and keep the centre up to the tap as it feeds in. A clean thread is required for the plug, therefore a sharp tap must be employed and paraffin used as a lubricant.

After boring out the first thread from the hole with a boring tool, as in Fig. 5, or counter-boring slightly with a  $\frac{1}{2}$ -in. diameter

drill to relieve the first thread, the casting can be removed from the chuck. The remainder of the turning is done off of the tapped hole and therefore the next step is to make a screwed peg like that being made in Fig. 6. Chuck a short length of  $\frac{3}{8}$ -in. or  $\frac{7}{8}$ -in. diameter mild steel bar so that about 1 in. is projecting from the chuck and turn it back for  $\frac{3}{8}$  or  $\frac{1}{2}$  in. to 12.5 mm. diameter, leaving a square shoulder. Make an under-cut against the shoulder  $\frac{1}{8}$  in. deep and screwcut the peg the same pitch as the tap. If the lathe used will not cut millimeter pitches, cut 20 threads per inch and reduce the diameter slightly to compensate for the slight pitch error.

Screw the head on to the peg and face the front of it until it is exactly  $\frac{1}{2}$  in. away from the bottom of the cored recess. Take another facing cut about  $\frac{1}{32}$  in. deep commencing from the outside and feed in until a shallow boss of 1  $\frac{1}{8}$  in. in diameter has been formed. Turn over the top to 2 in. diameter, when the head appears as in Fig. 7.

The outside can now be grooved to form the fins. First scribe a short line on the outside of the 2 in. diameter  $\frac{1}{16}$  in. away from the front edge. Similarly, make a mark  $\frac{3}{8}$  in. from the front edge. Grind a  $\frac{1}{2}$  in. parting tool with a slight radius to

remove the sharp corners and set the blade square with the work. Bring the left-hand edge of the tool up to the line first made and part in to a depth of  $\frac{1}{16}$  of an inch. After setting the right-hand edge of the tool against the second line and parting in to the same depth, two parallel sided fins  $\frac{3}{8}$  in. wide should be left standing. These require tapering on both sides from the point to the root so as to leave them  $\frac{1}{8}$  in. in width at the outside. The neatest way to do this is to set the top slide round almost square with the work and face the same side of each fin with the corner of the parting tool.

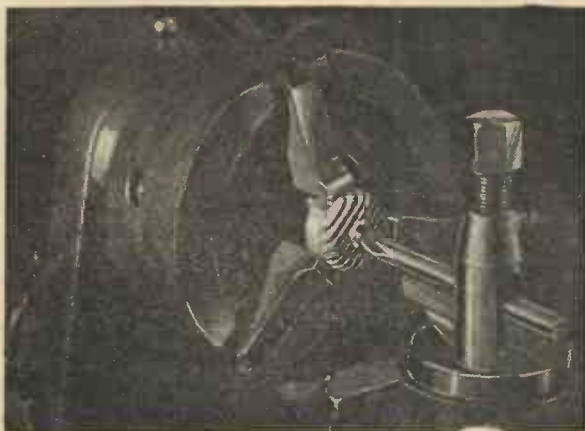
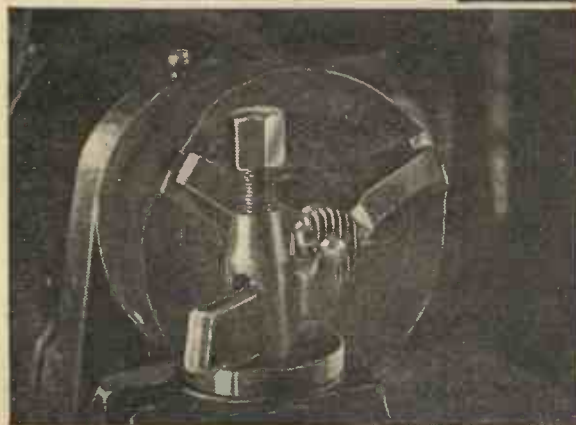

Fig. 5.—Boring out the first thread from the hole with a boring tool.

After setting the slide the same amount out of square in the opposite direction, face the reverse side of each fin in the same manner. Round off the top of each fin and also the sharp edge adjacent to the cross fins. Fig. 8 illustrates this point in the machining.

The cored recess on the front of the head is next bored to take the cylinder liner. When the liner is in position in the machined body casting it projects  $\frac{1}{16}$  in. above the top. It is on this projection that the cylinder head registers and makes a joint. Counter-bore the front of the head to 1  $\frac{1}{8}$  in. diameter, using the end of the liner as a gauge to obtain a good fit. The depth of the counter-bore is made a shade under  $\frac{1}{8}$  in. from the front face. The drawing calls for this measurement to be minus .005 in. This allowance is sufficient to ensure that the bottom face of the recess which, by the



Figs. 1-3.—(Left) Bringing the tops of the fins level with a light cut, (above and right) centre-drill and drill a hole right through the casting as shown.





# MODEL TWO-STROKE

## PART II (Continued from page 84 of the November issue) By W. H. DELLER

way, must be cleanly machined, will bed on to the top of the liner and make a joint when the engine is assembled. One other point before removing the head from the lathe, skim out the cored recess for piston clearance if necessary to 1 in. diameter for a distance of  $\frac{1}{2}$  in. behind the cylinder liner recess. Fig. 9 shows the head completely machined before removal from the lathe.

As a change from pure machine work the rough surface of the cored recess is finished off by hand work. This is where the

Sub-divide the face of the  $1\frac{1}{2}$ -in. diameter collar on the bottom of the head by means of a well-defined pitch circle of  $1\frac{1}{4}$ -in. diameter. This, by the way, could have been conveniently done before the head was removed from the lathe, with the point of a fine screw-cutting tool. Set the head on a V-block in such a position that the

straight portion of the cored hole, matching up with the baffle on the piston, lays at an angle of 45 degrees with the surface plate, and scribe a centre line across the pitch circle. Scribe a second line at right angles to it to give the positions of the four equally spaced stud holes. Centre punch carefully and drill No. 6 B.A. clearance holes with a No. 32 drill. The head can be rested on the fins, which were lightly faced on the lathe for drilling, as in Fig. 12. Great care has to be

### Cutting the Ports in the Liner

Now for the liner! First of all measure the diameter at each end, and in the mouth of the largest end scrape, in the lathe, a 60-degree chamfer, leaving a flat face at the edge  $\frac{1}{2}$  in. wide. Set the liner on V-blocks and divide the circumference into four equal parts with fine lines extending from end to end. Stand the liner on the surface plate with the chamfered end uppermost, as in Fig. 13. The marking-out which follows requires to be done accurately. At a distance of 1 in. from the bottom, mark a line extending about  $\frac{1}{8}$  in. on either side of one of the vertical lines, and  $\frac{1}{8}$  in. above this, mark another line of similar length. Move the liner round in a clockwise direction, and across the next vertical line scribe a line the same length as the other ones,  $\frac{1}{8}$  in. up from the bottom of the liner, and  $\frac{1}{4}$  in. below this scribe a second one. Move the liner round again as before, until the next vertical line is reached. On this one make a line 1 in. up from the bottom and  $\frac{1}{4}$  in. above it mark another one. These markings give the height and width of the transfer, intake, and exhaust ports respectively. Sub-divide the

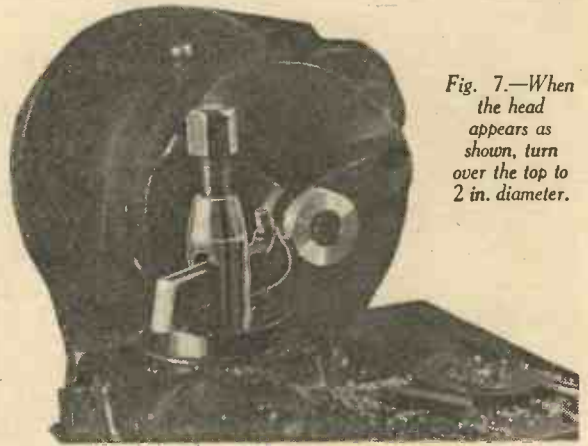

Fig. 7.—When the head appears as shown, turn over the top to 2 in. diameter.

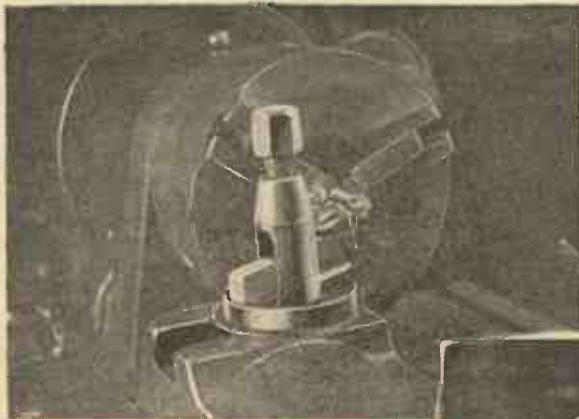

Fig. 6.—The next step is to make a screwed peg as shown.

screwed peg can again be utilised. Screw the head on to it and hold the plain portion of the shank in the vice. Remove all roughness from the interior of the head with small flat and half-round scrapers, as indicated in Fig. 10. Give a final polishing with fine emery cloth wrapped round a piece of wood.

Reduce the diameter of the shouldered portion of the screwed peg so that the thread will enter into the sparking plug hole from the inside of the head. This will then permit the head being held while the cast fins on the top are cleaned up by filing (see Fig. 11).

### Drilling the Head

The four clearance holes to pass the holding-down studs can now be drilled.

Fig. 8.—Round off the top edge of each fin and also the sharp edge adjacent to the cross fins.

taken in the marking out and drilling of these holes as the

face of the collar is but very little wider than the diameter of the drill. Turn the head over and counter-bore the holes, using a pin drill having a longish pilot, slightly below the root of the top fins. The diameter of the counter-bore must be such that it clears the corners of a 6 B.A. box spanner.



Fig. 9.—The head completely machined.



Fig. 10.—Remove all roughness from the interior of the head with a scraper.

width of the transfer port with a line, and on it at  $\frac{1}{2}$  in. either side of the vertical line make a punch mark with a fine centre-punch. Spot these up with a small drill and follow through with a  $\frac{1}{16}$ -in. drill. File each hole out D-shape so as to leave a vertical bar between the holes  $\frac{1}{8}$  in. in width. While filing protect the opposite internal face of the liner against accidents with a piece of card. Interline the width of the intake port as before, and drill  $\frac{1}{16}$  in. diameter holes on it at centre distances of a shade



Fig. 11.—The head being held while the top fins are cleaned.

over  $\frac{1}{8}$  in. on either side of the vertical line. File these holes out D shape also, to leave a centre bar  $\frac{1}{8}$  in. wide. Repeat the first stage of the marking on the exhaust port position and on this centre line and  $\frac{1}{8}$  in.



Fig. 16.—The liner ready for inserting.

either side of the vertical line drill a  $\frac{3}{32}$ -in. diameter hole. File these holes the same shape as the others, leaving a bar of the same width in the centre. As this port has to be  $\frac{1}{4}$  in. in width the holes must also be filed out wider to meet the lines and the rounded ends blended in with a small half-round file.

#### Drilling the Inlet and Exhaust Flanges in Jacket

Before inserting the liner into the cylinder jacket drill a  $\frac{1}{16}$ -in. diameter hole through the centre of the carburettor flange, shown in part elevation on the right hand of Part 1 on the blue print. Elongate this hole on the inside with a  $\frac{1}{16}$ -in. round file until it is  $\frac{1}{8}$  in. wide, to match up with the width of the corresponding port in the liner.

Drill a  $\frac{1}{8}$ -in. diameter hole through the centre of the exhaust flange seen in part section on the left hand of the same portion of the print. This is the operation being carried out in Fig. 14. The hole is then finished out to a rectangular shape, measuring  $\frac{1}{2}$  in.  $\times$   $\frac{3}{8}$  in. with radiused corners, by filing, as in Fig. 15. Remove any burrs left by drilling or filing from the bore of the cylinder jacket, and also see that there is no sand or un-



Fig. 13.—Stand the liner on the surface plate with the chamfered edge uppermost.

wanted roughness of the metal in the transfer channel.

Having noted and remedied any such defects the liner is ready for inserting. The body part No. 1 and liner part No. 6 are seen at this stage in Fig. 16 with the parts lined up in relation to the flanges.

#### Fitting the Liner

There are two ways in which the liner may be put in. The first is by pressing; the other way is to heat the cylinder jacket up slightly over a gas ring (see Fig. 17). This method is, to the writer's mind, the best, as the liner will then fall in and may be twisted, if necessary, to line up with the holes in the flanges. Have the liner handy and heat up the top portion of the aluminium body until the liner slides in. The chamfered end of the liner comes at the top of the cylinder.

#### Fitting the Cylinder Head and Drilling

When cool, put the cylinder head in position, with the straight portion of the core in the head opposite to the exhaust port, the stud holes being set square with the machined faces on the crankcase. Spot up the top of the cylinder jacket by passing



Fig. 15.—The port being finished out to a rectangular shape.

a No. 32 drill through the stud holes in the head as in Fig. 18, putting only sufficient pressure on the drill to lightly countersink



Fig. 17.—One method of inserting the liner.

the metal. Remove the head and drill four holes with a No. 44 drill square with the top face about  $\frac{1}{8}$  in. deep and tap out to No. 6 B.A.

Drill a hole with a No. 26 drill in the centre of the boss in the bottom of the crankcase and spot face, afterwards tapping out with a No. 2 B.A. tap to take the drain plug. Mark out and drill four  $\frac{1}{8}$ -in. clearance holes in the fixing lugs in part Nos. 2 and 3. Put the rear cover in position, that is on the left-hand side of the crankcase with the exhaust



Fig. 14.—A hole being drilled through the centre of the exhaust flange.

port facing and the main bearing housing in the opposite side with the bosses facing upwards. Spot through the fixing holes on each side into the lugs on the crankcase and afterwards drill out to  $\frac{3}{32}$  diameter and tap  $\frac{1}{8}$  in. to a depth of  $\frac{1}{16}$  in. Drill and tap the No. 6 B.A., fixing holes in the exhaust and carburettor flanges, and insert the necessary studs and screws. The shell of the engine, with the exception of a few holes for the ignition system, is completed by cleaning up the crankcase and trimming the flanges of parts 2 and 3 to suit.

A NEW WORK!

## POWER-DRIVEN MODEL AIRCRAFT

Petrol-, Compressed-Air and  
Steam Engines and Models

By F. J. CAMM

96 Pages. 130 Illustrations.

1/- from all newsagents or 1/3 by post from

GEO. NEWNES LTD.,  
8-11 Southampton Street, Strand,  
London, W.C.2.



Fig. 12.—Drilling the four stud holes in the cylinder head. Fig. 18.—Spotting up the stud holes after fitting the cylinder head.

# TRICKS WITH GLASSES

Simple Tricks for the New Year's Party that can be performed at the dinner table.

**C**ONJURING tricks always go down well with both young and old, especially at New Year parties, for they help to keep alive the spirit of entertainment and fun. Here are a number of tricks which can be performed with ordinary glass tumblers, and a little practice will soon make you perfect in any of these very simple "magic" feats, which can quite well be performed at the dinner table.

### Blowing "through" a Solid Object

For the first trick the performer produces a candle set in a candle stick, and arranges a tumbler in front of the candle, raised to the height as the flame. The tumbler should be with the open end up, as

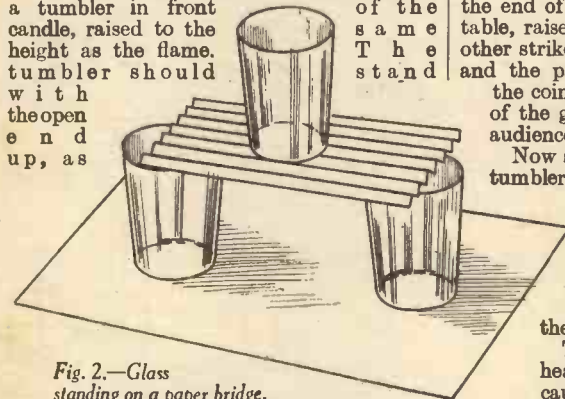

Fig. 2.—Glass standing on a paper bridge.

shown in Fig. 1. He then tells his audience that his gift of magic enables him to blow through solid objects. To prove this he blows with his mouth near the tumbler, and lo! the candle is extinguished.

There is nothing very mysterious in this really, because the single air current made by blowing on the glass divides and journeys round the tumbler, the two streams meeting on the other side and combining to blow out the flame.

The performer now tells his audience that he can support a tumbler on a single sheet of paper resting on two other tumblers. It seems impossible to carry the weight of a heavy tumbler on such a flimsy bridge, but he first folds the paper into accordion pleats, places the bridge across the two tumblers and then the third on the centre of the bridge, which remains quite rigid beneath its weight, as indicated in Fig. 2.

### A Question of Heat

Bringing forth a strip of paper and a coin and, of course, a tumbler, proceed to

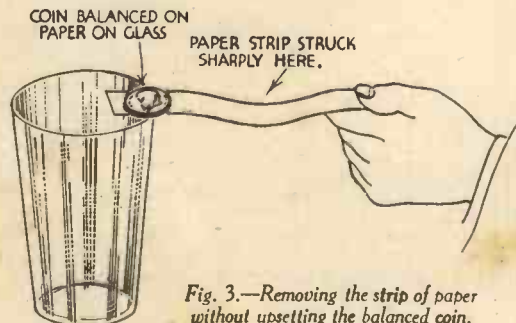

Fig. 3.—Removing the strip of paper without upsetting the balanced coin.

balance the coin delicately on the edge of the tumbler with one end of the paper strip between the coin and the glass. Now ask one of your friends to remove the paper without dislodging the coin. As a rule the victim will either try to jerk the paper away quickly or will draw it away very cautiously, thinking in the latter case that only gentle treatment will keep the coin in position on the tumbler. He will fail every time. But the performer takes the end of the paper which is lying on the table, raises it with one hand and with the other strikes the centre smartly (see Fig. 3) and the paper slides easily from beneath the coin, leaving it balanced on the edge of the glass, to the astonishment of his audience.

Now state that you 'propose to raise a tumbler from the table merely by pressing the palm of your hand over its mouth. Very simple, really! Just drop a lighted match into the glass, place your hand palm downwards on the mouth, and—hey presto!—up comes the tumbler.

The explanation? The match heats the air inside the glass, causing it to expand, but when the hand is placed over the glass the



match is extinguished, the air cools, causing contraction, which creates a partial vacuum, the suction of which holds the tumbler tight against the hand.

### Skill Required

This trick is one requiring skill and precision. Take a glass half full of water, reverse a plate over its mouth, and turn the whole arrangement over so that the plate is resting on the table with the inverted tumbler on top. You say you are going to drink the water from the glass using only one hand.

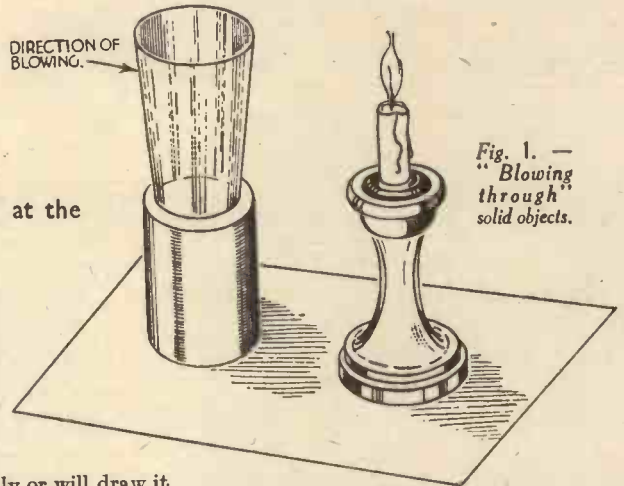

Fig. 1.—Blowing through solid objects.

Bend over, resting the top of your head on the upturned bottom of the glass (see Fig. 4). Press the tumbler tightly against your forehead by raising it up on the plate with one hand, balancing it in place and at the same time raising the head to Fig. 5 position. It is now comparatively simple to remove the plate and drink the water. Remember, though, that all this has to be done with one hand.

Another simple little trick is to knock a glass off the table on to the floor without breaking the glass.

The secret is to put the tumbler on the very edge of the table—mouth uppermost—and then to push it off gently with the right forefinger pressed lightly against the lower part. If this has been done carefully, the tumbler will make a half revolution in its fall and come to rest squarely on its rim. A smash from a fall like this is practically impossible, but it is advisable to practise the trick several times with a cushion on the floor.

A glass can be made to stand on the edge of its base in the following manner: a match is slipped surreptitiously under the table cloth, when, by a little manipulation, the tumbler can be tilted at an angle against the concealed match stick, as in Fig. 6. Thus the unusual sight of a tumbler standing on edge.

### Using an Egg

The entertainer now promises to get a hard-boiled egg into a milk bottle without damaging the egg. After removing the shell, he proceeds to fit the egg into the mouth of the bottle, demonstrating that it will not go in. We watch and wait.



Figs. 4 and 5.—The method of lifting and balancing the glass of water and plate on the forehead prior to removing the plate and drinking the water.

Soon we see the egg sliding down the neck of the bottle, and "plop"—it rests on the bottom unbroken.

This is brought about by placing a lighted match in the bottle to heat and expand the air, the subsequent contraction drawing the egg in. Better still, the trick can be made to appear more mystifying by placing the bottle on a radiator or concealed electric hotplate instead of using a match.

The completion of this trick will be, of course, to get the egg out again. To do this, compressed air has to be built up inside the bottle by blowing into it with the mouth. Then, still keeping the mouth of the bottle sealed tight with the lips, tilt the head backwards until the egg slips down and fills the neck of the bottle. Thereafter,

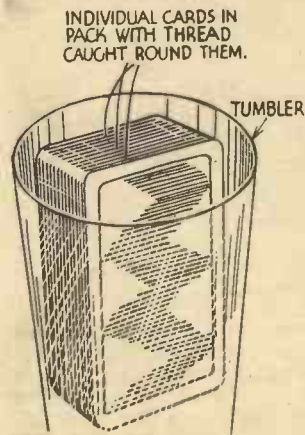

Fig. 7.—*Showing how thread is placed round each card it is intended to raise.*

If the bottle is set down on the table, the egg will slowly emerge.

### The Coin Mystery

The mystery of the next trick is greatly enhanced because, the tumbler being transparent, spectators imagine that they can see everything that is to be seen. Yet, in spite of this, it is quite easy to give the illusion of passing a coin right through the glass and into the tumbler.

What the audience sees is this: The performer lays a pack of cards across the top of a tumbler in such a way that the mouth is entirely closed. He then borrows half-a-crown, which suddenly disappears and as suddenly reappears inside the tumbler.

This is what actually occurs. The magician has previously concealed a half-crown in the palm of his hand—a feat known to magicians as “palming.” He then produces his pack of cards and arranges them in the form of a fan, holding the half-crown against the back of the pack and allowing the audience to see only the face of the cards. He next places the cards face upwards on the glass, taking care that the coin is caught between the glass rim and the pack. The weight of the cards will keep the coin in place. A handkerchief or table napkin is now placed over the cards.

The conjurer now borrows a half-crown from a member of the audience and, holding it in his right hand, appears to transfer it to the left, but really “palms” it. Waving his left hand, which the audience imagines holds the coin, over the glass, he taps the end of the pack opposite to the one covering the coin with the tip of his wand. Naturally, the cards are tilted and the coin falls into the glass with a resounding tinkle. A removal of the handkerchief and the cards provide an opportunity to slip the borrowed coin into the performer's pocket, and the original half-crown can be retrieved from the glass and returned to the owner.

### A “Magic” Card Pack

The last trick is really spectacular. Several members of the audience select cards from a pack. They are returned to the pack and the whole placed in a tumbler. The magician then gives a word of command and the selected cards mysteriously rise one at a time from the tumbler and fall face uppermost on the table.

Two packs of cards are required for this trick, one an ordinary pack specially prepared for the final dénouement, and the other, a trick pack known as a “forcing” pack, obtainable at all conjuring shops. The forcing pack is doctored in such a way

that the audience is compelled to choose certain cards. After these cards have been chosen they are returned to the pack, which can then be shuffled—if desired—by a member of the audience. When it is returned to the conjurer, he lays it down on the table and proceeds to arrange his tumbler and to indulge in any little by-play in order to distract his audience. He then picks up a pack of cards, not, however, the forcing pack, but a pack which he has himself prepared in the following way: He has knotted a long black silk thread through a hole in one card and has placed this card three or four cards down from the front of this pack. He has then arranged the thread up and over the top of the rest of the cards, and while held in that position, cards corresponding to those to be “forced” on the audience have been inserted at intervals, down the pack. Each card as it was pushed down into the pack has taken down with it a loop of the thread, as shown in Fig. 7. The loose end of the thread has been cut to a length of a couple of feet and a bent pin attached to the end.

Fig. 6.—*Balancing a glass on its edge.*



When this specially prepared pack is inserted in the tumbler, the performer hooks the pin into his clothing. Then, when he wishes to make the cards appear he moves his body slowly away from the pack, when the chosen card nearest to him will rise and fall out, followed by the other chosen cards until all have appeared.

ONE of the busiest departments at the Airway Terminus, London, is the Inquiry Bureau, which was established not long ago by Imperial Airways. Here, sitting beside a telephone, is an expert who is ready, at any moment, to answer questions concerning travel by air. He is surrounded by time-tables, weather data, and reports and information of all kinds. It is his job to know everything, not only about flights along the European air-lines, but also about the route from England to the East, and that romantic air line which takes passengers to the heart of Africa, and carries urgent loads in nine days from London to Cape Town. Nothing comes amiss to him. He is an airway encyclopædia.

This summer showed a growing popularity in tours in which flying alternated with trips by train, steamer and motor coach. The Inquiry Officer found much to occupy him in planning such combined trips for holiday folk. After flying to Cologne, for example, one can start picturesque trips by river steamer, or one can embark on motor coach tours of the Rhineland. There has been heavy air traffic this summer to the Belgian coast, where holiday-makers have a choice of many interesting excursions. In addition to such combined air-and-land excursions, there has been a marked increase lately in the number of passengers who arrange European tours in which they make all their journeys from city to city by air. In a trip lasting a week, one can pay flying visits to Amsterdam, Copenhagen, Berlin

## AIRWAY ENCYCLOPÆDIA

and Vienna, returning to London *via* Zurich and Paris. Or, by another itinerary—also lasting a week—one can fly to Paris, Zurich, Milan and Rome, returning to London *via* Marseilles and Paris. The advantage of such flying trips, as the Inquiry Officer will remind you, is that the speed with which you accomplish your journey gives you a maximum of time for sightseeing at the various cities en route.

### To the Belgian Congo

From arranging the details of a personally conducted tour to Switzerland, or a fortnight's excursion by flying-boat over the Mediterranean, the Inquiry Officer will turn to the details of an air trip as far as the Belgian Congo, or will pick up his telephone to tell some inquirer what time an air-mail letter posted in London will be delivered at Bangkok, in Siam. And then, after that, he may be running through the preliminary details of an expedition in which a party of hunters are to fly out to the big-game lands of Africa, taking their guns and equipment with them, and camping out each night under the wings of their machine.

Many of his queries concern dispatching mails by air, or the times of arrival in

London of air mails from points along the Empire routes. Questions crop up, too, as to catching some outgoing air mail with late and urgent letters. In such cases, even if ordinary letter-box dispatches may have been missed, it is possible to rush a letter to the Airway Terminus at Victoria in time to catch the motor coach leaving for the air port. There is also the possibility, as a last resort, of ringing up the post office at the air port at Croydon and dictating over the 'phone any short letter, which will be taken down and included in the load of a 'plane just about to start.

Parcel and freight transport by air is now so much on the increase that a good deal of time is occupied in answering questions from consignors who wish to send all sorts of articles by aircraft, not only to the Continent, but also along the Empire lines.

Inquiries are often received from passengers who ask what sort of flying weather they are likely to have next day, when they are due to leave on some air journey for which they have booked tickets beforehand.

Many of the questions that have to be answered deal with journeys along the Empire routes. When you fly from England to the heart of tropical or semi-tropical lands, and do so in a few days, you have to consider the clothing you will take with you.

In the majority of inquiries, as one might imagine, the time factor is all-important. This applies particularly to the booking of “air specials” or rush journeys.

# 1935 WILL EXPECT MORE FROM YOU THAN 1934 PELMANISM

develops those qualities which will ensure your success

LIFE moves at ever-swifter rate. The standards of yesterday will not do to-day—those of to-day must be keyed up to meet the needs of to-morrow. Swift, hard-thinking, quick decisions, a brain which goes direct towards its goal—these are the essentials of success in the future. Are they a part of your equipment? They should be—they CAN be, if you set to work in the right way.

## WHAT PELMANISM DOES—

IT WILL HELP YOU TO GAIN :—

- CONCENTRATION
- SELF - CONFIDENCE
- MORAL COURAGE
- WILL POWER
- ORGANISING POWER
- GOOD JUDGMENT
- LEADERSHIP
- INITIATIVE
- SELF - CONTROL
- PERSONALITY
- RESOURCEFULNESS
- CREATIVE ABILITY
- DETERMINATION
- RELIABLE MEMORY

And a host of other qualities indispensable to success.

THE 1935 REVISED AND ENLARGED EDITION OF THE PELMAN COURSE IS FULLY DESCRIBED IN THE FREE BOOK ENTITLED "THE SCIENCE OF SUCCESS."

WE SHALL BE GLAD TO SEND YOU A COPY OF "THE SCIENCE OF SUCCESS," 48 PAGES, POST FREE.

Address: The Secretary,

**The PELMAN INSTITUTE**  
130 PELMAN HOUSE, BLOOMSBURY STREET, LONDON, W.C.1.

PELMAN OVERSEAS INSTITUTES.—PARIS: 80 Boulevard Haussmann. NEW YORK: 271 North Avenue, New Rochelle. MELBOURNE: 396 Flinders Lane. DURBAN: Natal Bank Chambers. DELHI: 10 Alipore Road. AMSTERDAM: Leliegracht 30. JAVA: Kromhoutweg 8, Bandoeng. CALCUTTA: 102 Clive Street.



Photo by Kay Vaughan.

### A Personal Message

FROM MR. W. J. ENNEVER

(Founder of the Pelman Institute)

It is because no system in the world but Pelmanism can so surely, so speedily bring out the strong points of your character, and build up those possibilities which exist in everybody's mental equipment, that I ask you to find out more about Pelmanism. You yourself will be the first to admit that you do not wish to stay where you are—let us work together to fit you for a life that is worth while.

### HOW PELMANISM HELPS

**Commercial Traveller:** "Since taking up the Course I have more than trebled my income, which is due solely to your teaching." (L.18180)

**Clerk:** "I have been able to do better work and also to work more rapidly and accurately than hitherto, and to get ahead of my colleagues. Incidentally, it (Pelmanism) resulted in an increase of salary." (H.26398)

**Doctor:** "It is impossible for me to express adequately my appreciation of the Course and my sense of the enormous benefit I have derived; the gain I have already made is great. I only wish I had taken the Course years ago." (P.5115)

**Clergyman:** "I have received more benefits than I have space to record them. I have more energy. I have a better memory. I am succeeding more easily in my life's work. I have found the Course simply bristling with helpful features." (S.22335)

**Solicitor:** "I have no hesitation whatever in recommending the Pelman Course as a wonderful tonic to the mind and brain and an inspiration to the weak and diffident; and no one who practises the system perseveringly can possibly fail to receive great benefit." (K.6069)

**Engineer:** "Pelmanism has benefited me considerably. I have just got a post with £20 a month greater salary than I have ever held—namely, £60 a month and maintenance. I have got absolute confidence in myself." (L.26265)

To The Pelman Institute, 130 Pelman House, Bloomsbury Street, London, W.C.1.

Please send me, free and post free, a copy of "The Science of Success," with full particulars of the Pelman Course.

NAME .....

ADDRESS .....

Occupation .....

All correspondence is confidential.

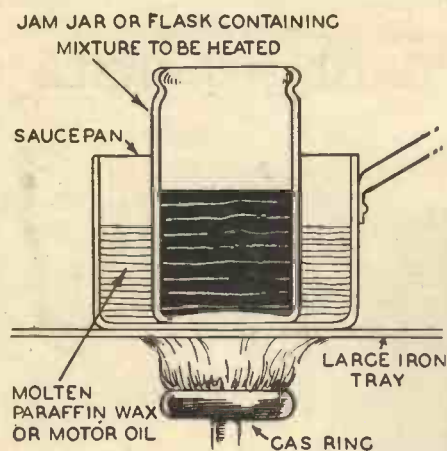

The simple apparatus used for making the dyes.

JUDGING from the text-books of dye-stuff chemistry, the amateur chemical experimenter may well be excused for considering the making of useful dyes to be too difficult and complex a task for him to undertake in the home laboratory. This is undoubtedly true as regards many of the more modern dyestuffs. Nevertheless, there are a few aniline dyes which can be made at home with a surprising amount of ease, and whose preparation entails the minimum amount of apparatus. Careful working during the preparation of these dyes will result in the obtaining of good yields of the dyestuffs. To this end, however, it is necessary to weigh and measure out accurately the various substances which go towards the making of the dyes, for failure to observe accuracy in this direction will result in the dye being contaminated with various unwanted impurities.

#### Naphthol Yellow

This is a yellow powder which dyes wool and silk a brilliant lemon yellow. Cotton must be "mordanted" by a previous steeping in weak alum or tannin solution before it will take the dye.

To prepare the dye proceed as follows: place 1 oz. (28 grams) alpha-naphthol and 2½ oz. of concentrated sulphuric acid in a fairly large flask. Place the flask in a pan of water and allow the water in the pan to boil for four to five hours, periodically removing the flask from the water to shake up the contents thereof. After the lapse of this time, remove the flask from the boiling water and pour the contents of it very cautiously (to prevent spurling) into 8 oz. of cold water contained in a large basin, the mixture being well stirred all the time and for several minutes afterwards. When the mixture has cooled down to room temperature, add to it very gradually and with constant stirring a mixture of 2 oz. of strong nitric acid and ½ oz. of water, care being taken that the temperature of the liquid does not rise above a medium heat. After the mixture has again cooled, strain it through a woollen cloth and wash the solid residue containing the dye free from acid by pouring over it strong salt solution in which the dye is not soluble. Finally, dissolve the dye in a small amount of water, add sodium carbonate to it until it is neutral, and then precipitate the dyestuff by stirring common salt into the liquid. The purified yellow dye is then filtered and dried in a warm oven.

#### Fast Green

This dye is prepared by dissolving ¾ oz. of resorcinol in 20 oz. of water and adding to the liquid 1½ oz. of strong hydrochloric acid and 4 oz. of common salt. The liquid

# HOME-MADE ANILINE DYES

A worth-while Occupation for the more-advanced Chemical Experimenter.

should now be allowed to stand until it is *dead cold*. Preferably, a few lumps of ice should be added to retain a low temperature. One ounce of sodium nitrite (not nitrate) dissolved in about 4 oz. of *cold* water is then added to the above liquid. It must be added drop by drop with thorough stirring, care being taken not to allow the temperature of the liquid to rise to any extent. The addition of the nitrite solution will take about an hour. After this, the liquid should be allowed to stand for two or three hours, during which time it will deposit a brown powder. This powder, which is the dyestuff, should be filtered off, washed with a small quantity of very cold water and dried at a gentle heat. Dissolved in water, it will dye silk and wool green. Cotton, after it has been steeped in alum or iron solutions, is dyed a lighter green.

#### Induline

This is not a difficult dye to prepare. It may be had in two forms, a spirit-soluble dye and a water-soluble one. Both forms of the dyestuff are blue, the water-soluble variety tending towards a violet-blue.

To make induline, place in a large flask 2½ oz. of aniline and add to it drop by drop ¼ oz. of strong hydrochloric acid and ¼ oz. sodium nitrite dissolved in a little water. Allow the well-shaken contents of the flask to stand overnight. Then place the flask in a pan of warm water for two hours in order to heat up the mixture a little.

Add now ¼ oz. of aniline hydrochloride (this can be prepared by cautiously adding hydrochloric acid to aniline and by collecting the white substance formed) to the mixture in the flask. Place the flask in a saucepan containing either molten paraffin wax or motor oil and heat the pan so that the wax or oil attains a temperature of well over the boiling-point of water. This heating should be continued for four hours, the flask being shaken from time to time, and, of course, great care being taken to ensure that the wax or oil does not catch fire. This is best ensured by heating the pan over a large iron plate. After the lapse of four hours or thereabouts, pour the mixture while it is still hot into a large basin of water which has been acidulated with a little hydrochloric acid. Spirit-soluble induline will be precipitated as a blue-black powder. It is filtered off and dried.

To make water-soluble induline, take a portion of the spirit-soluble dyestuff and dissolve it in five or six times its weight of concentrated sulphuric acid contained in a flask or jar. This mixture should be heated in a pan of boiling water until a small sample taken from the flask dissolves completely in a solution of sodium carbonate. The contents of the flask, after having been allowed to cool down, are then very cautiously poured into cold water. The dyestuff which is thus precipitated is filtered off and then dissolved in the smallest possible quantity of caustic soda solution. This solution is then evaporated to dryness and the resulting mass of water-soluble induline is then broken up and powdered.

#### Alizarine Yellow

This dyestuff dyes a golden yellow. It is made by placing in a 1-lb. jam jar ½ oz. of

pyrogallie acid (the photographer's "pyro") ½ oz. of benzoic acid and 1½ oz. of fused zinc chloride. The jar is stood in a saucepan containing paraffin wax or motor oil, and the temperature of the vessel is gradually raised above the boiling-point of water until the contents of the jar cease to foam, and until there is no increase of the brown colour therein. The jar is then allowed to cool down slowly, after which the product is powdered up, boiled with water and filtered. After the filtered liquid has cooled down, crystals of the dyestuff separate out. If they fail to do so, the liquid should be evaporated down to a smaller bulk and again allowed to cool.

Alizarine yellow is essentially a wool dye but it will dye cotton which has been previously soaked in alum solution.

#### Methyl Violet

This is one of the best-known dyes, and it has many uses. In the home laboratory, it is best prepared as follows:—

Take 1 lb. of common salt and mix it intimately with 1 oz. of powdered copper sulphate. Stir into the mixture 1 oz. of phenol (pure carbolic acid) crystals which have been dissolved in a little water. After this, add to the mixture with constant stirring 2 oz. of dimethylaniline. Now transfer the mixture to a large flask or jar and heat it in a pan of warm (not boiling) water for eight hours. After this time, pour the contents of the flask into a large basin and allow to cool. The mass will now contain the dye, methyl violet, together with phenol and salt.

The impure product should be broken up and added to 3 pints of water into which 1 oz. of lime has been stirred. This mixture is heated until all the lumps disappear. The liquid is then allowed to settle, and the clear solution of salt and calcium phenate is poured off from the residue at the bottom of the vessel. This residue is then boiled with dilute sulphuric acid in order to dissolve away the copper oxide which is present. It is then filtered, and solid sodium sulphate is added bit by bit, with constant stirring, in order to precipitate the dye. Finally, the precipitated methyl violet is filtered off and dried at a gentle heat. The dyestuff forms a greenish powder which dissolves in water, forming an intensely violet solution, which may be employed for dyeing purposes or for the making of inks and stains.

#### Sulphur Black

Here is an example of the sulphur class of dyestuffs. It is made by heating in a flask a mixture of 1 oz. dinitrophenol, 2 oz. flowers of sulphur and 5 oz. sodium sulphide (the latter dissolved in about 6 oz. of water). The flask should be placed in a deep pan containing water, and the water must be heated to near its boiling-point for twelve hours. The contents of the flask are then poured out into a large shallow vessel so that the liquid is enabled to expose a maximum surface to the air. As the liquid thus becomes oxidised, the sulphur black will be precipitated. It is soluble in a dilute solution of sodium sulphide.

**LOOK INTO WIRELESS TELEVISION THE FUTURE**



Television is the coming boom in wireless—it will bring even greater prosperity to the industry and create many more opportunities for a career. Men who foresaw the broadcasting boom made good—be trained and prepared for this television boom which must follow as surely as night follows day.

At the **WIRELESS COLLEGE** students receive training in all the latest developments in all branches of the Wireless profession. Marine, Aircraft, Manufacturing, Designing, Experimenting, Sales and Service, etc. *College on sea front. Write for free prospectus.*

**STUDENTS ACCEPTED AS BOARDERS. TRAINING FEE CAN BE PAID AFTER APPOINTMENT SECURED**

**The WIRELESS COLLEGE N. WALES**

**MICROSCOPES FOR ALL**

**SPECIAL OFFER OF 1,700 BRAND NEW STUDENTS' PORTABLE MICROSCOPES, as illustrated.**

Each model has inclinable body, swing mirror, stage clips, and is nicely finished in Black Crystalline Enamel and bright Nickel Plating.

**SHARP DEFINITION IS OBTAINABLE and GOOD WORK CAN BE DONE.**

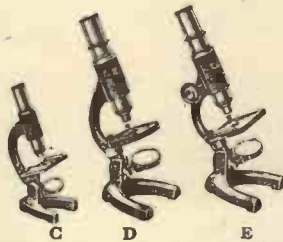

- Model C. Height 5½ in., sliding focus, magnification 25 x linear. Price **5/-**
- Model D. Height 7 in., sliding focus, circular stage magnification 50 x linear. Price **9/6**
- Model E. Height 7 in., rack and pinion focusing, magnification 50 x linear, square stage. Price **12/6**

**IMMEDIATE DELIVERY FROM STOCK. Post Free in Great Britain**  
**BROADHURST, CLARKSON & CO. 63 FARRINGTON ROAD LONDON E.C.1**

**"THE NAVIGATOR A.C. THREE"**

Select **Your Components from the Reliable GOLTONE RANGE**



**"GOLTONE" SCREENED H.F. CHOKES, type S.H.F. As used by Designer for the "NAVIGATOR A.C. THREE"**  
 Highly efficient, Robust mechanical Construction.  
 Inductance 250,000 mics. (approx.)  
 D.C. Resistance 550 ohms.  
 Current 50 m/a (max.) approx.  
 R5/S.H.F. Price **4/-** each.

A few components from the **"GOLTONE" RANGE**—  
 Filters for Scratch, Heterodyne, etc.  
 Second Channel Whistle Suppressor, Iron Cored Tuning Coils, Bakelite Lightning Arrester, Screened Down-Leads, Metal Screened Tubings and Conductors, etc. (as supplied to G.P.O., B.B.C., Admiralty, R.A.F. and leading set makers), "Nodalizer" Hum control and Suppressor, Statoformer, 6-Pin Plugs, H.F. Chokes, 8-Itches, Preset and fixed Condensers.  
 Send for free Radio Catalogue for full range of "Goltone" components, which are obtainable from first-class Radio Stores—refuse substitutes—If any difficulty write direct.

**FREE** ON REQUEST 1934-35 60 page Radio Catalogue of interest to every radio enthusiast.

**Ward & Goldstone**  
 PENDLETON MANCHESTER

**GREAT CHRISTMAS AND NEW-YEAR OFFER!**

A limited number of new B.T.H. Motors, 1/50 h.p. 2,000 R.P.M. Fitted with Special Bearings to allow motor to run horizontally or vertically

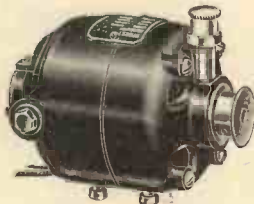

Universal! 110-250v D.C. or A.C. 50 or 100 cycles complete with resistance **30/-**

Carriage Free U.K. 105 pages.

Send to-day for the foremost Electrical List of 1935. Over 1,000 illustrations. Post free 3d.

The Catalogue of the Educational and Experimental World



**GRAFTON ELECTRIC CO.** (Dept. P)

Tottenham Court Rd., London, W.1



How many **MILES** have I walked?

**The PEDOMETER**

will tell you if you carry one in your pocket—it records ¼ miles up to 100 miles and can be set to zero at any time.

**18/6** Post free.

Catalogue No. P1570/255.

**W. F. STANLEY & Co. Ltd.** 286 HIGH HOLBORN LONDON—W.C.1

**HENLEY'S 20th CENTURY BOOK OF**

**10,000**

**MONEY-MAKING FORMULAS, PROCESSES & TRADE SECRETS**

(Complete in one large volume)

At this very moment there are millions of people who want to make more money, but cannot think of an idea; this book will be a wonderful help to such persons—it explains fully how to make and sell almost everything under the sun.

**BIG MONEY-MAKING OPPORTUNITIES** are waiting for both men and women.

With very little capital and without risk you may exploit thousands of proved ways of amassing wealth easily and quickly.

Fortunes have been made through this book, and thousands of people, with very little cash, are launching small business ventures, many of them based upon these formulas. Furthermore, numerous concerns, the owners of which were facing failure, have taken on a new lease of life, simply by seizing upon an idea contained in this vast storehouse of money-making facts and formulas. In many cases the cost of materials for starting a small manufacturing business are practically nil, owing to the utilisation of waste and by-products. There are, without doubt, hidden sources for profit-making which this book will disclose; it will show you how to break fresh ground, how to exploit avenues of money-making that at present seem non-existent

**THIS BOOK IS AN INVESTMENT THAT WILL PAY YOU A THOUSANDFOLD**

No licence or fee whatever is required to use any of these **10,000** Money-Making Formulas, Processes and Trade Secrets—for the purpose of making things or using the methods.

One Formula alone may make your Fortune, and this great book contains 10,000!

PRICE **25/-** or (O.O.D. 25/6) (or 10/- deposit, and three) (Post Free) (monthly instalments of 6/-)

C.O.D. and Instalment terms not applicable to Overseas Orders.

**The Scientific & Commercial Publishing Co. (Dept. P.M.5),** Artillery House, Westminster, London, S.W.1.

# INSULATION

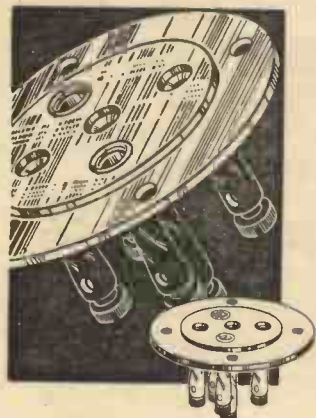

*CLIX  
Points of  
Advantage*

Clix Chassis Mounting Valveholders & Chassis Mounting Strips are

*specified for the*

**"NAVIGATOR  
A. C. THREE"**

# CLIX

Clix obtain maximum insulation by mounting only the heads of valve sockets in thin paxolin, providing true low-loss construction, with resultant gain in efficiency. Although thin, the insulation is very strong, and will not chip or fracture with careless treatment.

*Folder "F" Free.*

**LECTRO LINX LTD.**  
79a Rochester Row, London, S.W.1

## IMPROVE QUALITY AND RANGE

Revitalise your receiver with these British Made Valves which have received high praise from all the radio Press.

*Specified for the*

**"NAVIGATOR  
A.C. THREE"**

One each

AC/HL .. 9/6  
AC/L .. 12/6  
AC/VP .. 13/6

*Obtainable through all good dealers.*

*British made by :-*

**HIGH VACUUM VALVE  
CO. LTD.,**

113-117 Farringdon Rd., London, E.C.1

2-VOLT BATTERY VALVES FROM 3/9		
H 210	H.F. Amplifier...	3/9
D 210	Non-Microphonic Detector	3/9
DDT 220	Duo-Diode-Triode	7/-
L 210	L.F. Amplifier	3/9
P 220	Small Power	5/8
PP 220	Medium Power	6/6
PX 230	Super Power	7/6
Y 220	Medium Power Output Pen. Type	10/6
Z 220	Super Power Output Pen. Type	10/6
B 230	Class "B"	10/6
DB 240	Driver Class "B"	15/6
QP 240	Double Pen. Type for Q.P.P.	19/6
SG 215	Screen Grid	10/6
SG 220	High Slope Screen Grid	10/6
VS 215	Variable-Mu Screen Grid	10/6
HP 215	H.F. Pentode Type	10/6
VP 215	Variable-Mu H.F. Pen. Type	10/6
4-VOLT MAINS VALVES (A.C.) FROM 9/6		
AC/HL	Detector	9/6
AC/DDT	Duo-Diode-Triode	12/6
AC/L	Small Power	12/6
AC/Y	Output Pentode Type	15/6
AC/Z	High Slope Output Pen. Type	15/6
AC/SL	Screen Grid Amplifier	13/6
AC/SB	High Gain S.G. Amplifier	13/6
AC/VS	Variable-Mu Screen Grid	13/6
AC/VH	Variable-Mu High Gain S.G.	13/6
AC/HP	H.F. Pentode Type	13/6
AC/VP	Variable-Mu H.F. Pen. Type	13/6
UU120/350	Full Wave Rectifier (I.H.C.)	10/6
UU120/500	Full Wave Rectifier (I.H.C.)	15/-



**FIT HIVAC AND HEAR MORE**

## IN THE DECEMBER ISSUE

we quoted extracts from the unbiased opinions as expressed and printed by "The Wireless Magazine" and "Amateur Wireless" after they had fully tested out the Amplion "Radiolux" Superhet Receiver.

### NOW AS ALSO PROMISED BY US

you can read the full test report of the technical staff of your own publication. See page 162 of this issue.

# "RADIOLUX" SUPERHET RECEIVER



5-Valve including rectifier. For A.C. Mains 190/265 or 110 volts 40/100 Cycles.

AUTOMATIC VOLUME CONTROL, NEON LIGHT VISUAL TUNING FULL VISION SCALE ILLUMINATED, AND CALIBRATED IN METRES AND DEGREES, ENERGISED MOVING COIL SPEAKER, ALSO CONNECTIONS FOR GRAMOPHONE PICK-UP AND EXTERNAL SPEAKER. CABINET IN TWO-TONE WALNUT.

19 in. High. 15 in. Wide. 12 in. Deep.

D.C. MODEL 190/265 v.

A.C. MODEL.

H.P. Terms : £1 8 0  
Deposit and 12  
Payments of £1 2 9

**13 GNS.**

H.P. Terms : £1 6 6  
Deposit and 12  
Payments of £1 1 0

**12 GNS.**

Those desiring further technical details of this receiver or of the Amplion "Radiolux" Superhet Radiogram, which is also wonderful value for 21 guineas, should please write us for descriptive literature (Ref. P.M.).

AMPLION "LION" SPEAKER IS SPECIFIED FOR THE "NAVIGATION A.C. THREE" - PRICE 47/6

# AMPLION

**AMPLION (1932) LTD.**

82-84 Rosoman Street, Rosebery Avenue, London, E.C.1

Telephone : Clerkenwell 5440-5441



ALL RADIO  
QUESTIONS  
ANSWERED  
FREE.

Every Question  
must be accom-  
panied by the  
Coupon on  
page iii of Cover

# The PRACTICAL MECHANICS

## Wireless Experimenter

**M**ANY requests have been received from readers for a design for a really efficient and low-priced all-mains A.C. receiver, and the object in designing the "Navigator" was to satisfy these requirements. The set is not intended to be very pretentious, but it is one that can be built with remarkable ease and that may be trusted to give excellent reproduction and ample volume from ten or more stations. It will, of course, bring in far more transmissions than this when used in suitable conditions, and with a moderately good outdoor aerial, but the main object in designing the circuit was to ensure good, trouble-free reception of the nearer, British stations and the more powerful foreigners.

### Good Selectivity

The question of price was given full consideration, whilst suitability for modern conditions—especially with regard to the easy elimination of Droitwich, when required—was not overlooked. That is why the coils employed are of the double-wound, or H.F. transformer type. Another feature which is extremely valuable as an aid to selectivity and also for obtaining a complete control of volume is the incorporation of a variable- $\mu$  pentode high-frequency amplifier. This is followed by a leaky-grid detector, with reaction, and by an indirectly heated power valve; a pentode was found unnecessary, since the cheaper triode gave an ample signal output.

The mains equipment is of simple arrangement and entirely trouble-free, employing as it does a Westinghouse dry metal rectifier fed from a Heayberd mains transformer. Rectification is on the voltage-doubler principle, and the D.C. output available for the anodes of the valves is slightly over 200 volts, so that there is a little "to spare"

### THE NAVIGATOR A.C.

#### THREE

A reliable and inexpensive all-mains receiver which is easy to build

for the automatic biasing of the output valve. To ensure the complete elimination of mains hum, an 8-mfd. electrolytic condenser is used for smoothing the rectifier



A three-quarter rear view showing the neat and compact layout of the "Navigator A.C. Three."

output, while a grid-bias smoothing and by-pass condenser of 25 mfd. is used.

In order to prevent any possibility of instability or unsteady reaction control, the detector valve is adequately decoupled by means of a 30,000-ohm fixed resistance and a 2-mfd. fixed by-pass condenser.

### Simple Construction

The simple form of construction need not be emphasised, since it is clearly evident from the drawings and photographs reproduced. First of all the Metaplex

### Mounting the Electrolytic Condenser

Two of the holes for the valveholders (those of the 5-pin type) are 1 in. in diameter, but the third (for the 7-pin holder) is 1 1/4 in. in diameter. The two holes for the coils are 1 1/4 in. in diameter, and can be made at the same time as that for the valve holder. Additional holes must be made for the terminal strips, these holes being about 1/2 in. in diameter, and also for the 8-mfd. electrolytic condenser. There are actually two alternative methods of mounting this condenser, one being to make a 1 1/4-in. hole right through the chassis and mount the condenser on a metal plate, with 3/4-in. hole, attached to the underside; the other is to make a 1 1/4-in. hole half-way through the chassis from the underside, and then to make a 3/4-in. hole right through the centre of this. No matter which method is employed, the metal container of the condenser must make proper contact with the metallised surface of the wood, so that when the first-mentioned method is adopted a bolt must be passed through the plate and chassis to make contact with the upper surface of the latter.

Another point which should carefully be noted in mounting the components is that the mounting bracket for the reaction condenser should be insulated from the metallised surface of the chassis. This is best accomplished by scraping away the metal surface over an area rather larger than that occupied by the foot of the bracket; as a further safeguard, a strip of thin cardboard may be placed between the bracket and the chassis.

### Coil Connections

The wiring of the receiver should not present any difficulty, but a little information concerning the coil connections might be helpful. The coils are not fitted with terminals, but flexible leads are attached to

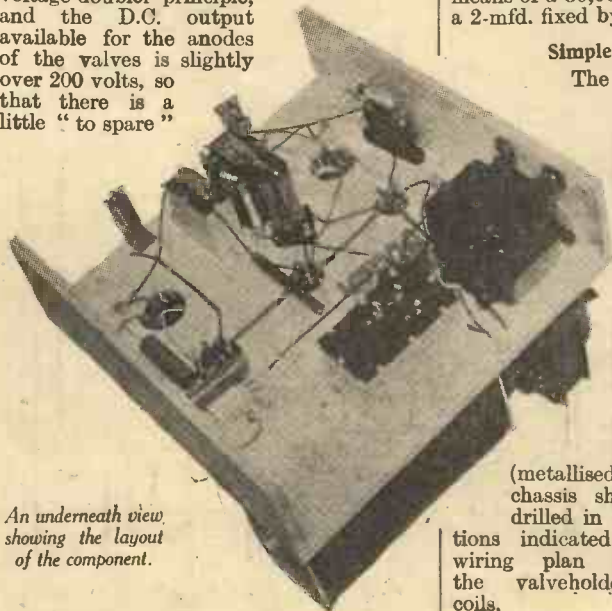

An underneath view showing the layout of the component.

(metallised wooden) chassis should be drilled in the positions indicated in the wiring plan to take the valveholders and coils.

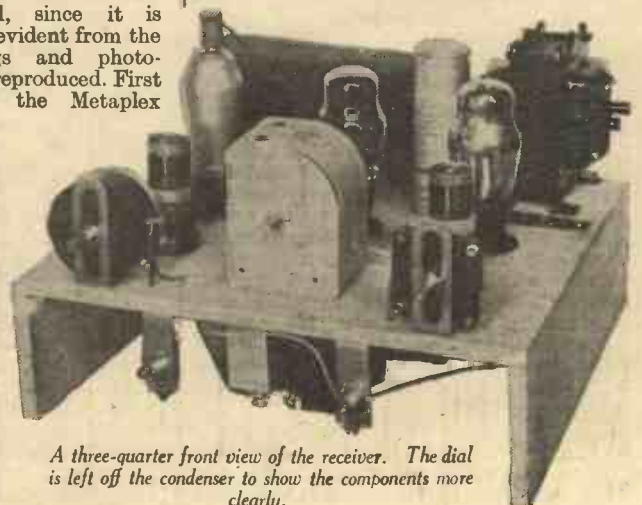

A three-quarter front view of the receiver. The dial is left off the condenser to show the components more clearly.

**LIST OF COMPONENTS**

- One Metaplex Chassis, 12 x 12 in., with 3-in. runners (Peto-Scott).
- Two 5-pin Valveholders (Clix).
- One 7-pin Valveholder (Clix).
- Two Terminal Strips (A and E, and L.S. and P.U.) (Clix).
- Two 2-gang Variable Condensers (J.B. Baby).
- One Condenser Drive (J.B. Type 2082).
- Two Navigator Coils (B.T.S.).
- One Screened H.F. Choke (Ward and Goldstone, Type R5/SHF).
- One 3-point Q.M.B. Switch (Bulgin Type 587A).
- One .0003-mfd. Reaction Condenser (Graham Farish).
- One L.F. Transformer (Varley "Nictet").
- Two 1-mfd. Tubular Condensers (T.M.C.).
- One 2-mfd. Condenser (T.M.C. Type 40).
- One 8-mfd. Electrolytic Condenser (T.C.C. Type 502).
- One 25-mfd. Electrolytic Condenser (T.C.C. Type 521).
- One 4 + 4-mfd. Fixed Condenser (T.M.C. Type B1001).
- One .0002-mfd. Tubular Condenser (T.M.C.).
- Five 1-watt Resistances: one 750 ohms; three 30,000 ohms, and one 2-megohm (Dubilier).
- One Smoothing Choke (Heyberd Type 752).
- One Mains Transformer (Heyberd Type W.16).
- One H.T.8 Metal Rectifier (Westinghouse).
- One Q.M.B. Switch (Bulgin S.80).
- One 1-Amp. Fuseholder (Ward and Goldstone).
- One 2,500-ohm Wire-wound Potentiometer (Varley).
- Connecting Wire, Screws, etc.
- Valves: Hivac, AC/VP (7-pin base), AC/HL, AC/L.
- One Moving-coil Speaker (Amplion Lion).

the contact tags. These leads are coloured for easy identification, the colour coding being as follows:—

**First (Aerial) Coil—**

- Aerial lead—pale blue.
- Earth lead—black.
- Wave-change switch lead—yellow.
- Grid and tuning condenser leads (two)—white.

**Second (Inter-valve) Coil.**

- Grid and tuning condenser leads (two)—white.
- Detector anode lead—dark blue.
- H.T. positive—red.
- Reaction condenser lead—green.
- Wave-change switch lead—yellow.

As these connections and colours are indicated on the wiring plan, there should be no difficulty in following them.

**Final Trimming Adjustments**

After the wiring has been completed, the set can be tried out by inserting the valves, connecting aerial, earth, speaker and mains leads. First set the reaction condenser to its minimum (anti-clockwise) position, turn the wave-change switch to the medium-wave position and then rotate the tuning knob until a station is received. After that, signal strength can be increased by adjusting the reaction condenser, and then the two-gang condenser can properly be trimmed. To do this find a station near the bottom of the dial, turn the trimmer screw on the front section of the condenser to its midway position and slowly turn the second screw, by means of a long screw-driver, until signal strength attains a maximum. In order to check this adjustment, tune to a station near the top of the dial and see if any alteration of the trimmer is required; if so, slightly alter the position of the front trimmer. It will probably be found, however, that reception is best when both trimmers are approximately in their mid-way positions.

**Fitting the Set into a Cabinet**

Once the trimming adjustments have been made the set can, if desired, be fitted

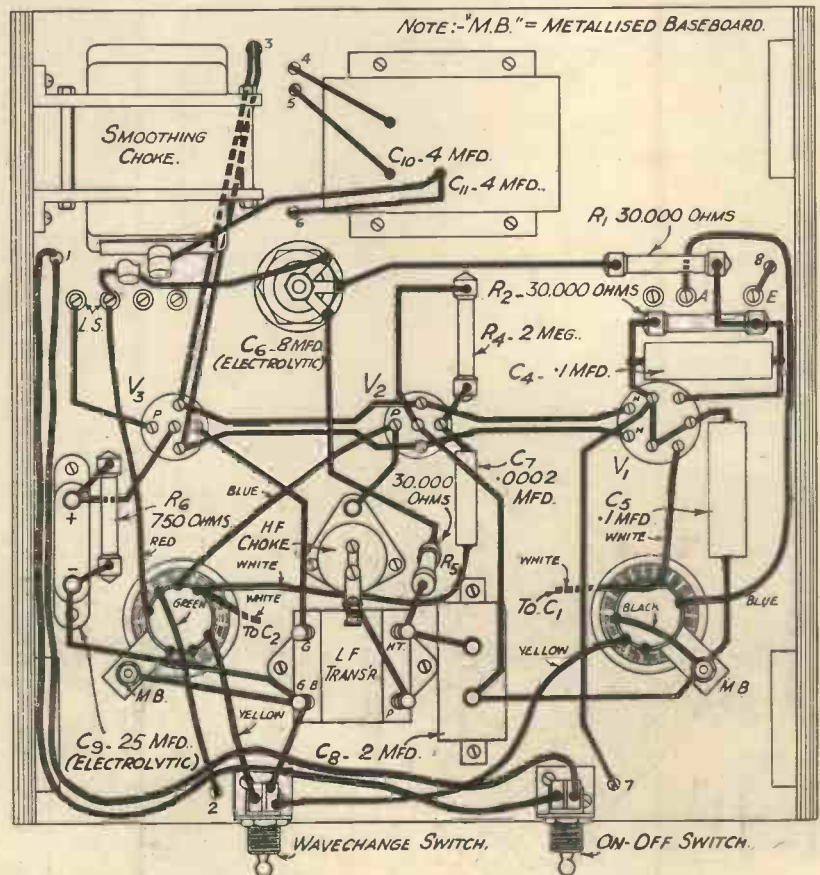
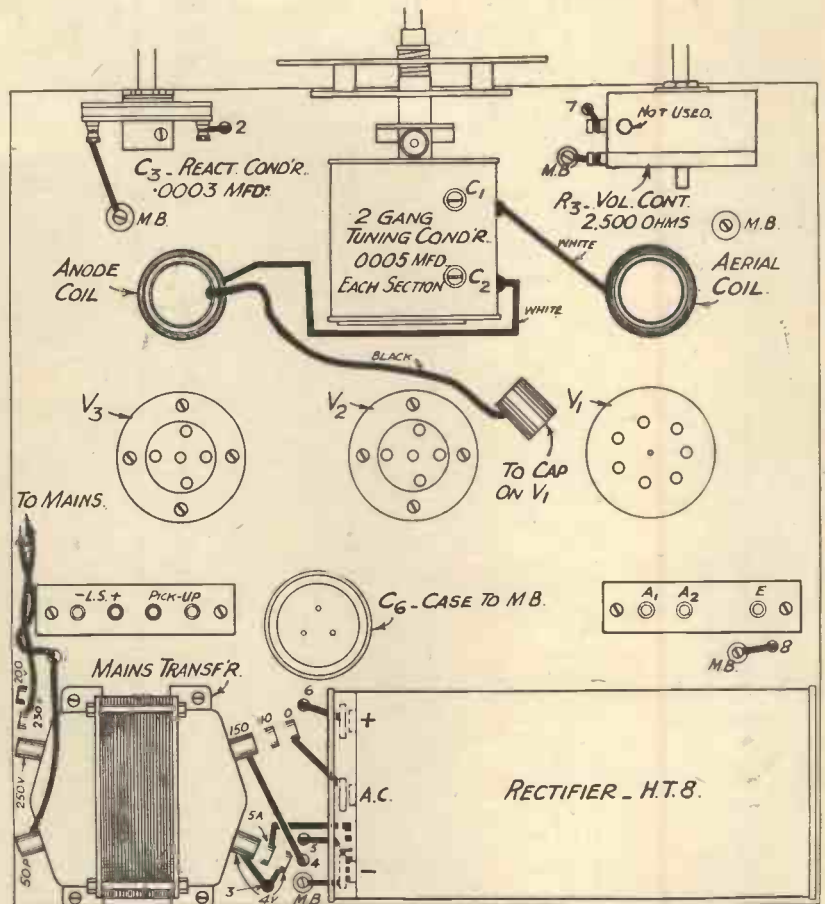

The above and underneath wiring plan of the "Navigator A.C. Three."

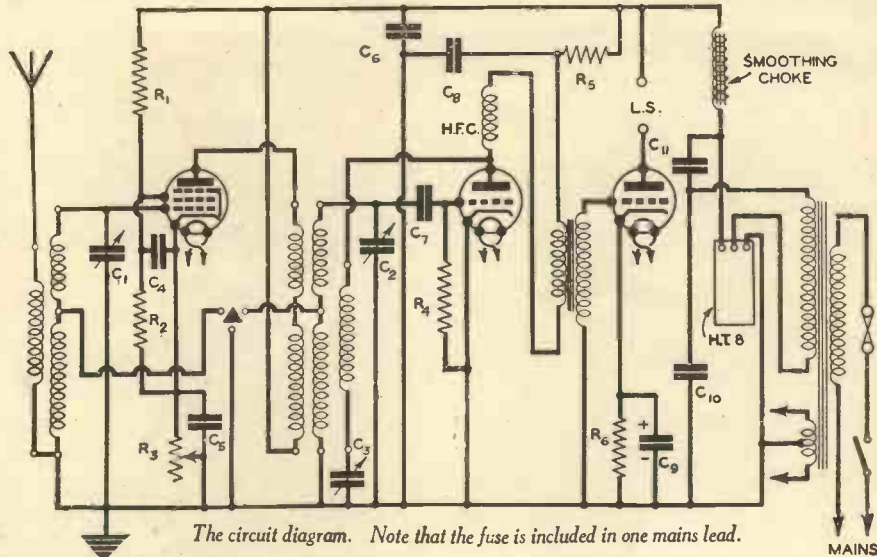

The circuit diagram. Note that the fuse is included in one mains lead.

$\frac{3}{8}$ -in. diameter, for the reaction condenser and volume-control potentiometer  $\frac{1}{2}$  in., whilst the sizes and positions of those holes required for the condenser disc drive are given on the template sent out with this component. It might be mentioned in passing that the condenser drive is not shown in the photographs appearing on a previous page, since it was removed in order to make the rest of the components more clearly visible.

**Connecting a Pick-up**

There are no pick-up connections shown in the wiring plan or circuit diagram, but a gramophone pick-up can easily be attached by joining the two leads to the two ends of the detector grid leak. It will be found that the quality of reproduction is just as good on gramophone as on radio, and the "Navigator" might well form the nucleus of a reliable radio-gramophone of modern type.

into a suitable cabinet. We have not specified any particular cabinet for the purpose, but the constructor can make his choice from a wide range which is made by Messrs. Peto-Scott. Alternatively, the receiver may be fitted into an existing cabinet of either the plain, or radiogram type. The dimensioned drawing of the front of the chassis given on this page will make quite clear the positions required for the holes which receive the controls, and the best method of transferring these dimensions to the cabinet is by making a full-size template, through which the centres of the holes can be pricked with a bradawl. Another method is to hold the complete

chassis against the inside of the cabinet and mark the positions from the projecting component spindles.

After having marked the centres,  $\frac{1}{8}$ -in. holes can first be run through the cabinet from the back, after which the full-size holes should be drilled from the front. All of the holes can be made with a centre-bit held in a brace, those for the switches being

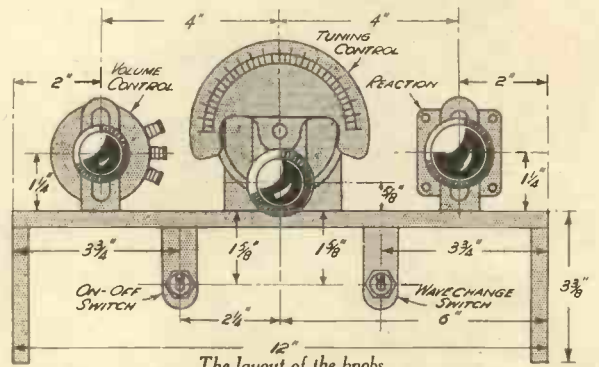

The layout of the knobs.

# AGAIN!! HEAYBERD

HAVE BEEN EXCLUSIVELY SPECIFIED FOR THE—"NAVIGATOR A.C. THREE"

MAINS TRANSFORMER MODEL W.16 - Price 24/-  
L.F. SMOOTHING CHOKE MODEL 752 - Price 12/6

Send NOW with 3d. in stamps for our latest 1935 Handbook "Mains Power for Your Radio"

F. C. HEAYBERD & CO., 10 Finsbury St., LONDON, E.C.2

## The "UNICORN" Electric Drill IS INDISPENSABLE TO ALL MECHANICS

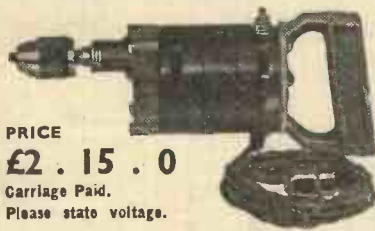

PRICE  
**£2.15.0**

Carriage Paid.  
Please state voltage.

Efficient, a model of accuracy and workmanship, and trouble-free qualities are the features of this drill. Its equipment comprises a powerful A.C. or D.C. Motor, voltages 100/120, 200/230, 230/250, with Armature Shaft in ground alloy steel. Hobbled gears in metal housing. Hoffman ball thrust. Keyless chuck,  $\frac{1}{2}$ -in. capacity. Aluminium die cast handle. Current consumption 175 watts, using  $\frac{1}{2}$ -in. drill on mild steel. 8 ft. Cab tyre flex with earth wire. Weight 5 lbs.

The drills are British Made and are designed for drilling up to  $\frac{1}{2}$ -in. diameter and are guaranteed under these conditions for six months and are now in constant use in many factories. Send for Illustrated leaflet to:—  
**CORONA ENGINEERING CO., Leighton Place, Kentish Town, N.W.5**  
Tele.: GULLIVER 3739

# GET A HOME CINE

FOR A FEW SHILLINGS DOWN!

Pay the balance over\* a further 8 equal monthly payments while enjoying movies at home. Get in touch with us now—Don't let the winter go by without this splendid home entertainment.

## PATHESCOPE HOME MOVIE

(as illustrated), embodies in miniature, with the greatest simplicity, yet with the maximum of working efficiency, all the principles of professional motion-picture projectors. A perfectly clear, brilliant, flickerless picture, 3 ft. by 2 ft. 6 in. is shown at 10 ft. from the screen.

£6/15/0 9 monthly payments of 15/9

EVERY CINE MODEL IN STOCK

LISTS FREE AND POST FREE

THE LARGEST AND BEST HOME CINE

DEMONSTRATION ROOMS in ENGLAND



# CITY SALE & EXCHANGE

(1929) LTD.

59 & 60 CHEAPSIDE, LONDON, E.C.2

# BINDING YOUR ISSUES OF "PRACTICAL MECHANICS"

With very few tools it is quite a simple matter to bind your own copies of "Practical Mechanics"

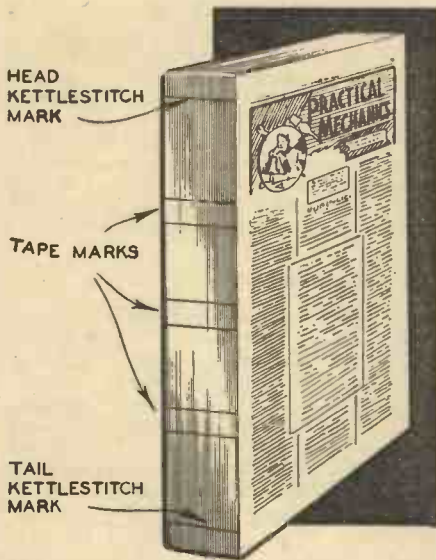

Fig. 2.—Details of the sewing positions, which are shown by the pencil marks.

**T**HERE are very few tools needed for bookbinding—a shoemaker's hammer, a sharp knife, a large darning needle, a glue pot and brush, a bone paper folder, and an ordinary wooden bench-vice for pressing. If a vice is not available the improvised press shown in Fig. 1 will admirably suit the purpose. The local bookbinder or any stationer should supply all the necessary materials.

Begin by piling up the Numbers 1 to 12 in their correct order. Now, starting with No. 12, tear off the paper cover and remove the wire staples. PRACTICAL MECHANICS is made up into three folded "sections" tacked lightly together with glue. Separate these and scrape off any old glue with a sharp knife, taking care not to damage the paper in doing so. Treat the remaining magazines in the same way, finishing with No. 1 on top of the pile. Run through the pile to make sure every section is in its proper place.

The book is now ready for sewing together. On the end of the first section make dots  $\frac{1}{4}$  in. from the top and bottom. Divide the space between the dots into four equal parts and on either side of these marks make further dots  $\frac{1}{4}$  in. apart. Using the first section as a guide, mark the last section in a similar manner. Replace the sections in their respective positions and knock up the

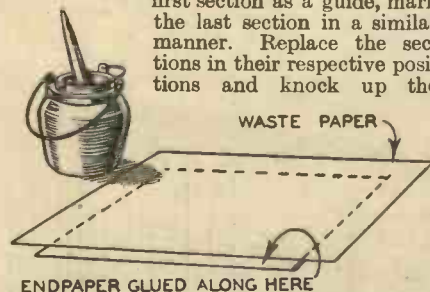

Fig. 5.—The method of gluing the cartridge endpapers at the front and back of the book.

book until the head and back are quite level. Draw pencil lines across all the sections joining the dots already made. The resulting marks on each section give the sewing positions (Fig. 2).

### The Sewing Equipment

A darning needle, a hank of 3-cord thread and about a yard of  $\frac{1}{2}$ -in. linen tape, are now required. Special bookbinder's tape is preferred. It is a special stiff variety and so easier to manage than the ordinary tape.

The latter may be used, however, and if desired, stiffened with thin glue.

Cut three pieces of tape long enough to go round the back of the book and overlap about 2 in. on each side.

Thread the needle with a good length of thread. Place the first section face downwards on the table, holding it open with left hand. Pass the needle through the head "kettlestitch" mark, leaving an end about 3 in. long, out at the first tape mark, in at the second, and so on until the needle finally comes out at the tail kettlestitch mark. Slip the tapes through the three loops thus formed, holding the 2-in. overlap

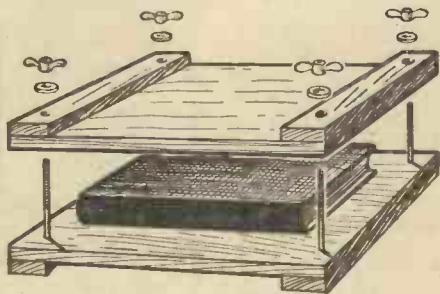

Fig. 1.—A simple form of press.

under the section, thereby keeping the tapes in position. Pull up the thread tight and place the second section in position, making sure it is level at head and back. Pass the needle through the tail kettlestitch mark of this section round the tapes to the head. Draw the thread tight, always pulling in the direction of the needle in doing so, to prevent tearing the paper, and tie to the loose end left at the start (Fig. 3). Place the third section in position and sew back again to the tail. At this point it is joined to the second by a kettlestitch, or loop stitch, as shown in Fig. 4. The fourth section is sewn in the same direction as the second, joining the third at the head with another kettlestitch.

### New Threads

The sewing proceeds in this manner, passing the thread round the tapes, pulling tight and kettlestitching at the ends, until the whole book is completed. Sewing is an operation that takes a fair time and it should not be hurried. When new thread is required it is tied to the old length, but always on the outside.

The back of the book swells considerably in sewing, and to reduce this it is lightly tapped with the hammer every six sections or so, holding the book firmly while doing so.

With the sewing completed the title page and index is to be "edged on," together with the endpapers. The endpapers are simply two pieces of folded white cartridge paper, cut to the size of the book, that protect the first and last pages.

Edge on the title page first by placing it face downwards on a waste sheet of paper and laying another sheet  $\frac{1}{4}$  in. away from the folded edge. Glue the exposed strip, and taking up the page lay it in position on the book. Rub the glued portion with the finger tip. Edge on the cartridge endpapers at the front and back of the book in the same way (see Fig. 5). The book is now put in the press or vice to reduce the swelling further. In the case of the home-made press, care should be taken to keep the screws even, tightening each nut a little at a time, thus ensuring an even pressure on the book. Screw down as hard as possible.

### The Pressing Operation

After pressing for about an hour the book is ready to be glued up. This operation consists of brushing glue over the back and rubbing it in the grooves of the sections with the fingers. This holds the sections together more securely.

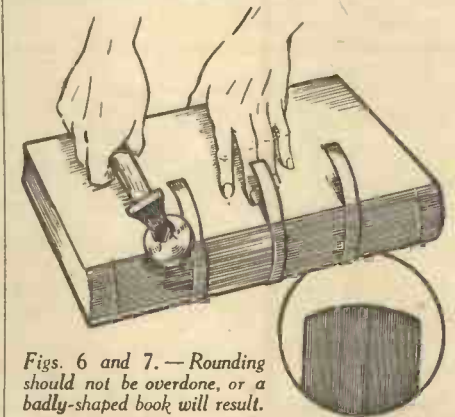

Figs. 6 and 7.—Rounding should not be overdone, or a badly-shaped book will result.

The fore-edge has now to be cut level, but the head and tail edges are left until later. If the sewing has been done well and the sections are fairly level, it may be put in the vice between two strawboards and sandpapered with fine sandpaper.

With the fore-edge cut the book has now to be "rounded." This gives the book that familiar round formation at the back and fore-edge. Another object of rounding is

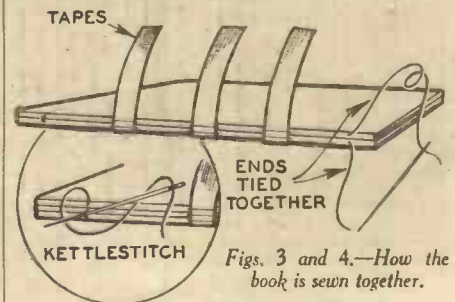

Figs. 3 and 4.—How the book is sewn together.

(Continued on page 196).

Fig. 1.—A close-up view of the business end of the machine gun camera.



# THE AERIAL GUN-FIRE RECORDING CAMERA

An interesting camera which enables the airman to gain accuracy without danger.

THE infantryman, along with the other members of the defences of the country, has to gain a great deal of practice in the use of his weapon of offence and defence, and much of his time is spent at the "butts." Here targets composed of linen or canvas stretched over frames are raised or lowered from concealed dugouts, and firing of actual bullets is carried out at varying distances, the hits on the target being signalled by various means. The airman, unfortunately, cannot fire at aeroplanes, although there are many other interesting devices for his practice. For instance, a "sausage" (similar to the familiar wind-stocking raised at the aerodrome to indicate the direction of the wind) may be towed by an aeroplane, but there will naturally be a risk of the

novitiate hitting the tower, or at any rate, the spent bullets when they fall to earth may have sufficient impetus to cause injury if they should hit anyone. Ammunition costs money, and this is a further deterrent to actual firing in the air. There is a very novel solution to the problem, however, and this lies in what is known as the camera-gun. The illustrations on this page show an American form of this invention—which, like all sound things, was the invention of an Englishman during the Great War.

### How the Gun Works

The airman is provided with machine-guns, some of which are designed to fire "through" the propeller, and others of which are fixed to movable mountings so that they may be pointed in any direction. The famous British Scharff mounting is for the use of an observer and permits the gun to be raised to any angle at the same time as it swings round the cockpit, and thus provides a really universal mounting. The camera-gun is generally used with one of these mountings in preference to the forward firing type, as it is more easily replaced for practice, and requires less dismantling in order to provide for films or actual "rounds" as desired. The gun is built almost to the proportions of the actual gun in use—in this country the Lewis, and in the illustrations a famous American gun. Where the normal ammunition is fed to the firing chamber a small box is built, into which fits a roll of standard camera film such as would be used by the man-in-the-street in a  $3\frac{1}{2} \times 2\frac{1}{2}$  in. camera. The process of loading and unloading is exactly similar to that in the

popular hand camera, and the film is, in fact, almost the same as can be bought in the average store.

Mounted in the "muzzle" of the gun is a glass screen over which is engraved the familiar rings of a target, bull, inner, magpie, and outer. In addition, two lines representing the vertical and horizontal diagonals are marked. The "trigger" of the gun operates a shutter as in our familiar hand cameras, and a mechanism similar to the normal recoil-loading apparatus of the genuine machine-gun changes the film, rolling round the exposed section and bringing the next into position. A small



Fig. 2.—When the film magazine is in place, the camera mechanism is lowered into the well in the gun case.

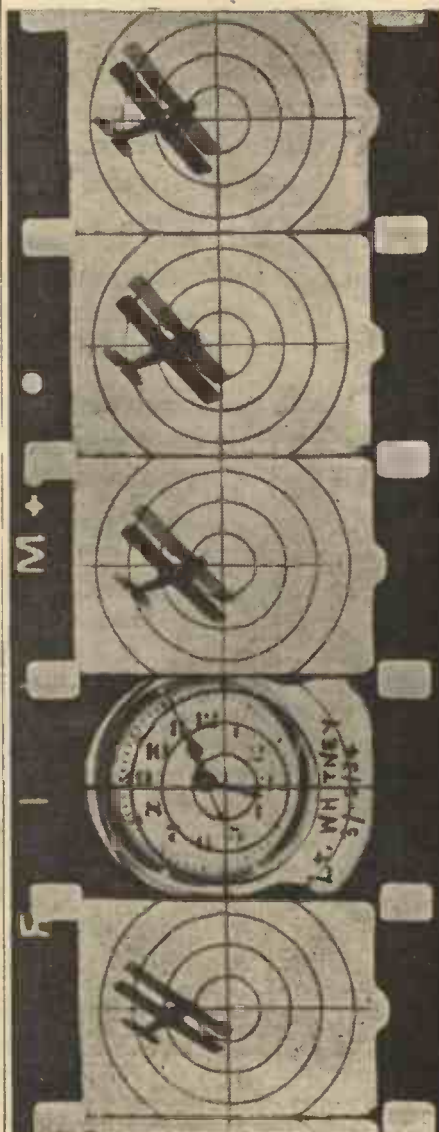

Fig. 3.—Some interesting examples of bursts of "fire" made with the camera gun.



**"but you  
are only  
a  
mechanic!"**



How can you reasonably expect the boss to promote you to a responsible post purely on your practical skill as a Mechanic?

Modern Engineering demands, more than ever before, a sound knowledge of underlying technical principles. Without this knowledge a mechanic cannot hope to get out of the "hammer and file brigade."

Yet, never before, were there so many glowing opportunities for bedding yourself down into a comfortable post where you will not be paid by the hour, and will not be looked upon as "part of the machinery," to be started and stopped at will.

A few letters after your name will put you "head and shoulders" above your fellows, and will open up opportunities for better paid jobs, which are at present closed to you.

The 1935 edition of our Handbook "ENGINEERING OPPORTUNITIES" shows just where these opportunities lie and the easy way in which you may prepare for them. Among a host of interesting things the book gives details of all recognised "pay-raising" Examinations, such as A.M.I.C.E., A.M.I.Mech.E., A.M.I.A.E., A.M.I.E.E., A.M.I.W.T., G.P.O., C. & G., B.Sc., Matric., etc., and outlines over 100 Home-Study Courses in all branches of Civil, Mech., Elec., Motor, Radio and Aero. Engineering, Building, etc.

Under our Guarantee of "NO PASS—NO FEE" you are completely safeguarded.

★ **Be advised** before the next man steps in front of you. Send for your **FREE** copy of "ENGINEERING OPPORTUNITIES" to-day, and learn what chances you are missing. The book is FREE and is bound to help you, whether you go any further in the matter or not. **Send a postcard to-day.**

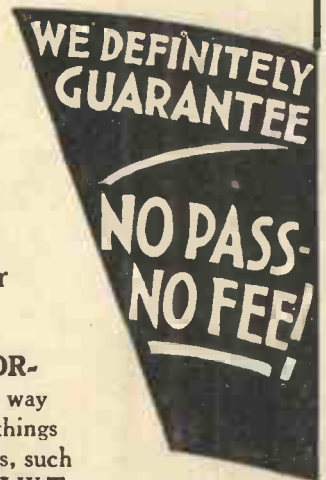
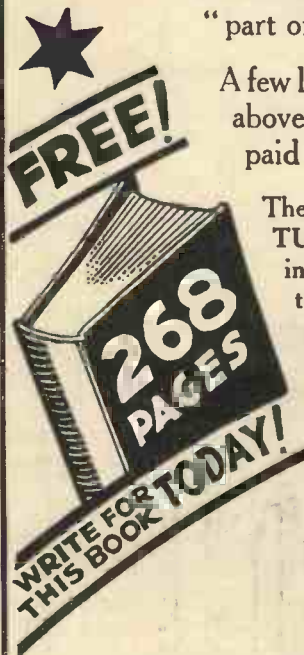

## BRITISH INSTITUTE OF ENGINEERING TECHNOLOGY

(Principal: PROFESSOR A. M. LOW, D.Sc.)

410 SHAKESPEARE HOUSE, 29-31 OXFORD STREET, LONDON, W.1

Sth. African Enquiries: P.O. Box 4701 Jo'burg.

Australasian Enquiries: P.O. Box 3597 Sydney.

# MANUFACTURING A MODEL TANK LOCOMOTIVE

AN INTERESTING TOUR OF A MODEL-MAKING FACTORY



Fig. 2.—Shaping the boiler barrel—a very intricate operation.

It is an interesting and comparatively rare privilege to go over a big model locomotive factory and see the production of every type of railway accessory. Locomotives, coaches, rolling stock, track, signals and points—everything a model railway owner wishes for—can be traced right from their very beginnings—a sheet of steel, a bar of iron, a rod of brass—until, in an incredibly short space, the finished article stands before us, spick and span.

The most fascinating process of all is the quantity production of a model locomotive, because this contains the greatest number of operations and calls for more intricate preparation than accessories with no initial power unit. A particularly interesting scale model is the new six-coupled tank loco-

motive recently produced by a famous Northampton model-making firm.

### Producing the Design

The locomotive is first designed in the draughtsman's office by a skilled engineer-draughtsman with knowledge of manufacturing diffi-

culties, and the finished drawing goes to the selling department for approval. From the approved design a hand sample is produced, and at the same time the "blanks" are made. Thi is highly skilled work, and has to be very carefully executed, as the accuracy of the whole batch of locomotives depends on the correctness and detail of the sample. From the "blanks," skilled workers fashion out tools in hardened tool steel by means of a hand press. These are very expensive to produce,

and are the manufacturer's heaviest production cost. Meanwhile the designs of the locomotive are reproduced in correct colours on tinned steel sheets by a lithographic process. This finish is not affected, like enamel or paint, by the various manufacturing operations.

The press tools, fitted up in huge power presses, stamp out these tinplate parts in a

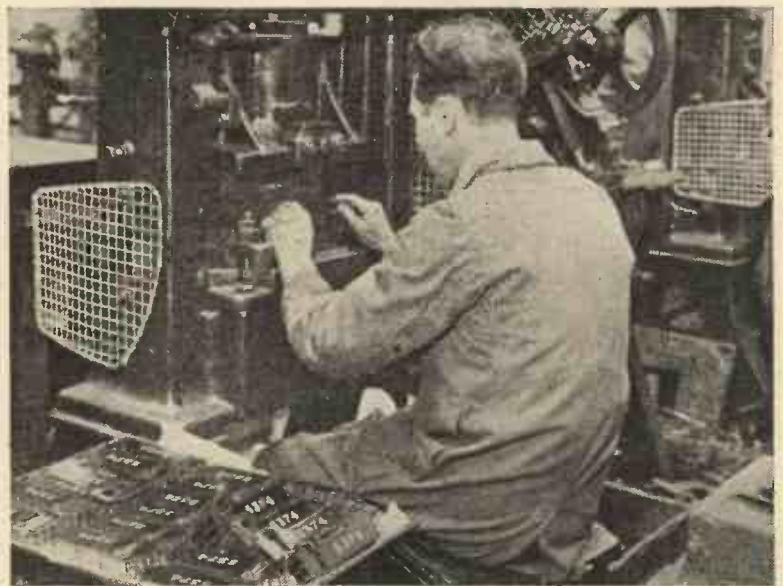

Fig. 1.—Press work on the tinplate parts. Stamping out the cab sides.

culties, and the finished drawing goes to the selling department for approval. From the approved design a hand sample is produced, and at the same time the "blanks" are made. Thi is highly skilled work, and has to be very carefully executed, as the accuracy of the whole batch of locomotives depends on the correctness and detail of the sample. From the "blanks," skilled workers fashion out tools in hardened tool steel by means of a hand press. These are very expensive to produce,



Fig. 3.—A part of the assembling table—fixing the buffers and buffer beams to the under-framing.

series of four or five operations. The part in Fig. 1, a cab side, is blanked in the first press and passes to others for the following operations—beading over the edges to take off sharpness, embossing the outline, piercing assembling holes, cutting and turning over the lugs which fix the parts together. The various tinplate parts, cab and tank sides, boiler, cab roof, under-framing, buffer beams, are all produced in this way, taking many, or few, operations according to the intricacy of the part.

### The Presses

These are formidable pieces of machinery, giving a pressure of over 40 tons on the ram head, but before this can descend  $\frac{1}{4}$  in. the operator's hands are thrust away by the safety guard, which comes down automatically with the tool.

Another press operation, illustrated in Fig. 2, is shaping the boiler barrels. In the foreground are two circular boiler barrels as they appear before the final shaping. Curving the boiler is done by a process which inevitably causes the lugs to curve inward. As the tool comes down on the barrel on the press it forms the firebox sides, and flattens out the lugs ready for fixing to the underframe.

After press work comes the assembling,

when the solid parts, chimneys, domes, safety valves, buffers, cylinders, bogie and driving wheels, meet the tinplate parts.

#### Assembly

Fig. 3 shows a model maker fixing the buffers and buffer beams to the underframing. The chimney, dome and steam valve are also fitted to the boiler barrel, and Fig. 4 shows the cylinders being assembled. In the case of clockwork or electric locomotives, the cylinders are merely dummies, which have no effect on the working of the locomotive. They are put there for correctness and accuracy of detail, which is so necessary in a scale-model locomotive. These solid parts, which add the finishing touches to a model, are cast in steel moulds from liquid alloys of aluminium and zinc, and are polished and finished on lathes and hand polishers.

#### Colouring the Models

The smart black and red locomotive bodies pass round the assembling table, nearing completion, until only the mechanism and driving wells are missing. Now each body is prayed with varnish, and this bright finish is made permanent in a special drying oven. The mechanism, whether clockwork or electric, comes from a different department, with the six-coupled driving wheels already attached, and it is fitted into

MODEL AEROPLANES AND AIRSHIPS  
1/-, or 1/2 by post from  
Geo. Newnes Ltd.,  
8-11 Southampton Street, Strand, W.C.2



Fig. 4.—Assembling the cylinders.

the tank body, and the complete locomotive now goes through the hands of expert finishers, who repair any little defect which the finished model may have sustained during manufacture.

Now each body is sprayed with varnish, and this bright finish is made permanent in a special drying oven.

#### Tests

Before boxing, every locomotive is tested for speed, power and ability to negotiate curves. The tank locomotive illustrated, although six-coupled, runs easily on a 4-ft. diameter circle, and is therefore particularly appropriate for indoor railways of limited space. Models of six-coupled passenger expresses like the "Royal Scot" and "Flying Scotsman" require a diameter of at least 6 ft. to run satisfactorily.

#### Over 400 Operations !

The manufacture of this locomotive is certainly an interesting process. There are over 400 operations in it, but progress in the model-making industry is increasing every year, and two, three and even four operations can often be performed simultaneously, or on the same machine.

Tools are the most expensive item, and they run up the cost of a scale model, but once made, they will last practically for ever.

## AN IMPORTANT WELDING DEVELOPMENT

IN the laboratory, numerous interesting experiments can be carried out which, for one reason or another, have no commercial application. Until recently, the electric welding of aluminium castings came within this category, and therefore practically the only method employed was that of the oxy-acetylene blow pipe.

Unfortunately, oxygen unites readily with aluminium at welding temperatures, and the application of any flame causes the rapid formation of oxide, which is one of the fundamental difficulties of welding this metal and its alloys. This oxide is a poor conductor of heat, and the operator has to break through it by a process called "puddling," or must dissolve the oxide by use of a special flux.

The electric arc, however, contains no oxygen other than that which may be drawn from the air, and it will be clear that if aluminium can be welded electrically the formation of oxide and its attendant disabilities will be greatly reduced.

#### Several Years of Experimenting

After experimental work extending over a period of several years, Barimar Ltd., the scientific welding engineers, of 14-18 Lamb's Conduit Street, London, W.C.1, who have already a well-founded reputation for reliable aluminium welding, are now able to utilise the electric arc for the welding of this material and to undertake these repairs under their "money-back" guarantees. Apart from the question of oxide, another important advantage is the localisation of heat. Although the electric arc is considered to have the higher temperature, the heat of the oxy-acetylene flame is diffused over a wider area, and as aluminium is a rapid conductor of heat, it is difficult to weld any part of a casting of this material without other portions of the work being affected.

The hall-mark of a skilful oxy-acetylene welder is his ability to judge and control the effects of heat to a nicety; failure in

An electrical process for welding aluminium, giving more perfect results at reduced cost.

this respect leads to distortion, and subsequent need for rectification. By the aid of the electrical method, the chances of distortion are virtually eliminated, and as machining is reduced to a minimum, substantial savings in cost are effected and quick delivery ensured.

#### Remarkable Results Obtained

There may be cases in which the old method will still be used, but these are likely to be few, for remarkable results are being obtained with the electrical method. Difficult examples of work, such as broken crankcase supports, which have been smashed off the main casting, and main bearing housings which have parted company with the rest of the crankcase, are typical instances of the type of work which is now being handled at the Barimar workshops. The former class of repair indicates the strength of this new method of welding, and the latter the perfect accuracy that is achieved.

It has been said that the application of electric welding is enormous, and so far, the potentialities remain almost unrealised. Certainly the process described opens up large possibilities, particularly for the heavier classes of work.

The truth of these remarks is impressed upon anyone

who is fortunate enough to have the opportunity to witness the large amount of work of this kind in daily progress.

Barimar have been instrumental in introducing several advances in modern welding methods, but none has been quite so striking as this commercial system for electrically welding aluminium castings.



Showing a welding operation in progress.



# CHAMPIONS of the MODEL WORLD!

For speed, efficiency and realism—supreme. ALL the excitement of driving Stanier's new design 2-6-0 "MOGUL" Monster is yours, if you are the possessor of this wonder model here, fitted with double action piston valve cylinders—one of the finest gauge "O" all-British models yet built.

Matt black with silver lining is the colour scheme of the fine American express below, which, among other things, is fitted with a remarkable amount of detail—cow-catcher, imitation glass windows and imitation coal on the tender, and will negotiate a curve of 3 ft. radius.

This New York Central Railway model costs **7 Gns.** Electric 20 volts a.c. Sequence reversing from cab or track.



Single Cylinder Traction Engine. Burrell Type. A finished model of this fine engine costs **16 Gns.**

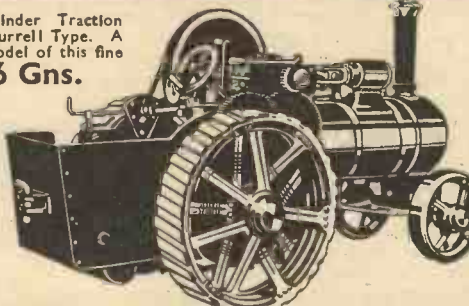

The pistons and valves of this new Stanier model are of stainless steel, and it has modified Walschaerts' valve gear. 18 inches overall, it is supplied in either black, or L.M.S. Red for those who wish to use it for Passenger Service.  
Price, steam, and electric **£5 5 0**

This splendid Traction Engine should greatly interest readers of PRACTICAL MECHANICS. Mr. Camm has made one, and the complete set of castings, parts and drawings can be obtained, as well as the finished model. Full details are in the BASSETT-LOWKE Stationary Engine List, B.12, price 6d. post free.

**HAVE YOU HAD YOUR COPY of the NEW BASSETT-LOWKE Model Railway Catalogue?** Not since the war have there been so many new fascinating models in this book. Price 6d. only, New A.12 is a wonder book for boys.

If you have not asked for "RUN YOUR OWN TRAIN SERVICE," the new photogravure booklet Bassett-Lowke have just produced, write for it this moment. Just send a penny stamp for postage and ask for Free Booklet No. 12. If you live near London, Northampton, or Manchester, there is a great chance for you. Call in at the BASSETT-LOWKE shops there and see the models

**BASSETT-LOWKE LTD.**  
NORTHAMPTON London: 112 High Holborn, W.C.1  
Manchester: 28 Corporation Street

**FITTED CHESTS OF GUARANTEED TOOLS**

47 Strongly made Standard Size Tools British Made

**50/-** F.O.R.



EVERY TOOL FULLY GUARANTEED

**Free Gift** to every purchaser of the above a 6/6 Volume on "Home Wood Work" will be sent free.

- CONTENTS**
- |   |                        |
|---|------------------------|
| 1 Hand Saw, 24" Blade                               | 1 Smoothing Plane      |
| 1 Tenon Saw, 10" Blade                              | 1 Brace                |
| 1 Keyhole and Pad Saw                               | 3 Centre Bits          |
| 12" Blade.  | 1 Set of 3 Gimlet Bits |
| 1 Claw Hammer                                       | 1 Square               |
| 1 Pin Hammer  | 1 Axe                  |
| 2 Files (Handled)                                   | 1 Oilstone             |
| 1 Rule  | 1 pair Pincers         |
| 1 Gouge (Handled)                                   | 1 Small Screwdriver    |
| 3 Chisels (Handled)                                 | 1 Large Screwdriver    |
| 2 Brad Awns   | 1 Glass Cutter         |
| 2 Gimlets   | 1 Spokeshave           |
| 1 pair Pipe Grips                                   | 1 Punch                |
| 1 pair Construction Pliers                          | 1 Level                |
| (cutter, broad grip and flat grip, and wire cutter) | 1 Marking Gauge        |
| 1 Oil Can   | 1 Cork Rubber          |
| 2 Pencils   | 2 Sheets Sand Paper    |
| 1 Soldering Iron                                    | 1 Rawlplug Outfit      |
| 1 Tool Chest  | 1 Instruction Book     |
|   | 1 Croid Glue           |
|   | 1 Tin Fluxite          |
- Complete in Fitted Chest

**Special Notice**

**TOOLS TOOLS TOOLS**



**New Catalogues Just Issued**

1. Catalogue of SPECIAL OFFERS FREE. Post 2d.
2. Catalogue of Tools for Bricklayers, Plumbers, Plasterers, Slaters, etc. Postage 3d.
3. Complete Catalogue of Woodworkers' and Metalworkers' Tools (243 pages, fully illustrated), 2/- post free. The amount of 2/- may be deducted from first order of 10/-.

**S. TYZACK & SON, Ltd.**  
(DEPT. P.M.5)  
341, 343 & 345 OLD ST., LONDON, E.C.1



There was a young fellow named Fred  
At the Garage he was always ahead  
He was just a mechanic—Who just didn't panic—  
But calmly used FLUXITE instead!

See that FLUXITE is always by you—in the house—garage—workshop—anywhere where simple, speedy soldering is needed. Used for 30 years in Government Works and by the leading engineers and manufacturers. Of all Ironmongers—in tins 4d., 8d., 1/4 and 2/8.

Ask to see the Fluxite Small-Space Soldering Set—compact but substantial—complete with full instructions—7/6. Ask also for Leaflet on Case Hardening Steel and Tempering Tools with Fluxite.

**THE FLUXITE GUN**

is a handy and economical tool that enables you to put the Fluxite where you want it on the soldering job, and is clean and simple to use. Nothing to remove—no mess—no trouble.

Always READY FOR USE.  
Also used to project grease into grease cups, bearings, etc.

Just fill the nozzle portion—half fill the cup—put together and press as required.

PRICE 1/6

ALL MECHANICS WILL HAVE

**FLUXITE**

IT SIMPLIFIES ALL SOLDERING



FLUXITE LTD. (Dept. P.M.), DRAGON WORKS, BERMONDSEY STREET, S.E.1

# THE PRINCIPLES OF THE ELECTRIC MOTOR

An interesting article dealing with the electric motor in all its phases.

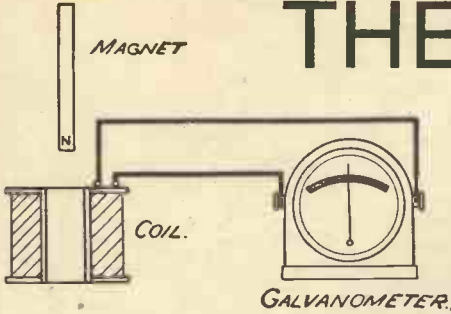

Fig. 1.—An experiment with coil and magnet to illustrate electro-magnetic induction.

ALL electro-magnetic machines depend on the principle of induction discovered by Faraday in 1831. A coil of wire is connected in series with a sensitive galvanometer that has a central zero. If a bar magnet is now passed into the coil, the galvo will "kick," indicating that a current is flowing in the wire. Now remove the magnet and the needle will be deflected in the opposite direction (see Fig. 1). Move the magnet quickly and then slowly, and notice that the deflection depends upon the speed, or the rate of cutting lines of force. The explanation is, that round the bar magnet there is a field of

Experiments have been performed that prove that the mechanical force is proportional to the strength of the field and current, and the length of the conductor.

### The Action of an Electric Motor

To understand the action of an electric motor, consider a wire in a uniform magnetic field, and assume that the current is passing through the paper and perpendicular to it, then the wire will move in the direction of the arrow (see Fig. 2). If a rectangular coil is suspended by two flexible conducting ligaments in a similar field and a current passed through it, then the coil will turn and set itself at right angles to the lines of force. Since the coil remains stationary in this position, then mechanical work is only being done while it is turning through 180 degrees. The problem is to keep the coil moving, and this is achieved by fitting a commutator.

and rotates on the head of the pin. Fix two bar magnets, one on either side of the coil, with a north pole opposite a south, touch the two pins with flexible leads from a 3-volt dry battery, and the armature will revolve at quite a rapid speed (see Fig. 4).

### Series, Shunt, and Compound Wound

Modern machines are divided into three classes—series, shunt, and compound wound—and each has its own particular application. In these three types the armature is in series with the field coil; in the shunt the field is connected across the

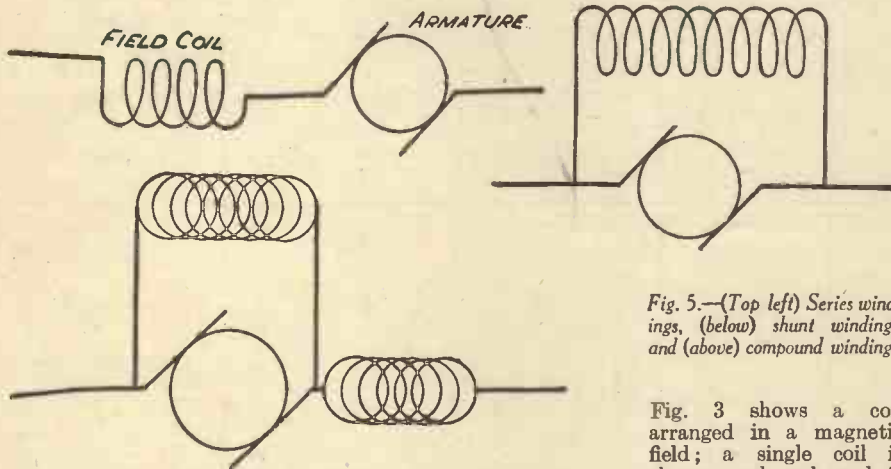

Fig. 5.—(Top left) Series windings, (below) shunt windings, and (above) compound windings.

Fig. 3 shows a coil arranged in a magnetic field; a single coil is shown, and each end is

fitted with a plate upon which bears a brass brush. A current is then passed through the coil, causing it to rotate until it is vertical; in this position the brushes bridge or short-circuit the segments, but the momentum of the coil carries it past this spot. It will be clearly seen that the current is reversed in the coil, and so it continues to rotate. This may be easily demonstrated by winding a coil of wire on a cork, push two pins in for commutator segments and connect the ends of the coil to them. A third pin is pushed through a small hole in a piece of tin and then into the cork so that the arrangement is suspended,

and when these cut a wire that lies perpendicular to them, a voltage is induced in the wire which depends on the rate of cutting of the lines. An electro-magnet may be considered as a magnet and will give the same results if used in the above experiment. It will be seen that mechanical work has to be done to produce electrical energy; thus if the above process is reversed, mechanical energy will be liberated. Reconsider the above experiment; if a magnet is placed before the coil and a current of electricity passed through the coil, then the magnet will be either drawn into or expelled from the coil.

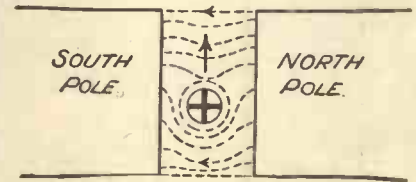

Fig. 2.—Diagram illustrating principle of electric motor.

armature, and the compound combines both the windings as in Fig. 5, which shows the three types. Series-wound machines are used for traction work on trams and electric locomotives, since they exert a large force when the machine is at rest and just moving slowly. Shunt-wound machines run at constant speed for varying loads, and are used for general work, such as line shaft driving where the load varies between quite large limits. The compound-wound machine may be designed for three definite purposes—to obtain a high starting force with a maximum speed limit on light or no loads, thus combining the shunt and series machines, and secondly to obtain a speed load characteristic in between the shunt and series machines; and thirdly, to obtain a constant speed at all loads, and thus correct the shunt motor variations. It will be seen that it is useless to install a series-wound machine to drive, say, a small lathe, because as soon as the machine is started, it runs up to a very high speed; the lathe is operated and the motor slows down, but as soon as the work is finished, it again runs up to a high speed. This characteristic may be seen in the smallest models. The external appearance of the three types is just the same provided that they are in the same frames. Fig. 6 gives the characteristics of these motors.

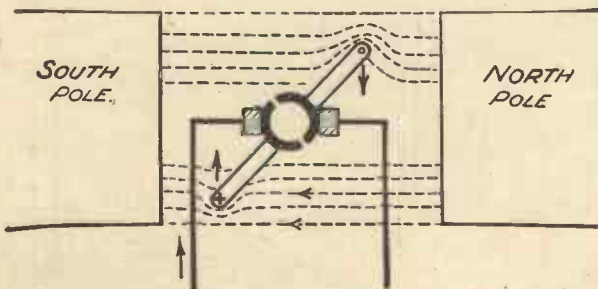

Fig. 3.—A further diagram showing the principle of the electric motor.

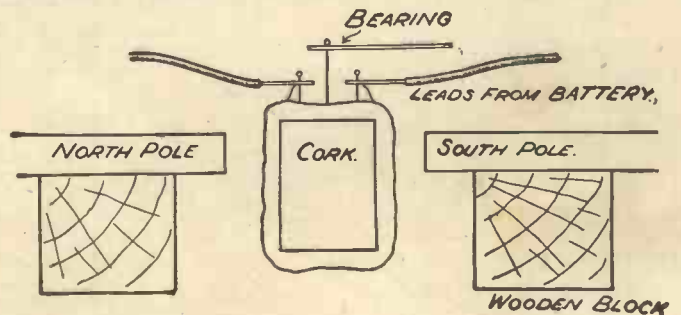

Fig. 4.—An experiment to illustrate the principle of the electric motor.

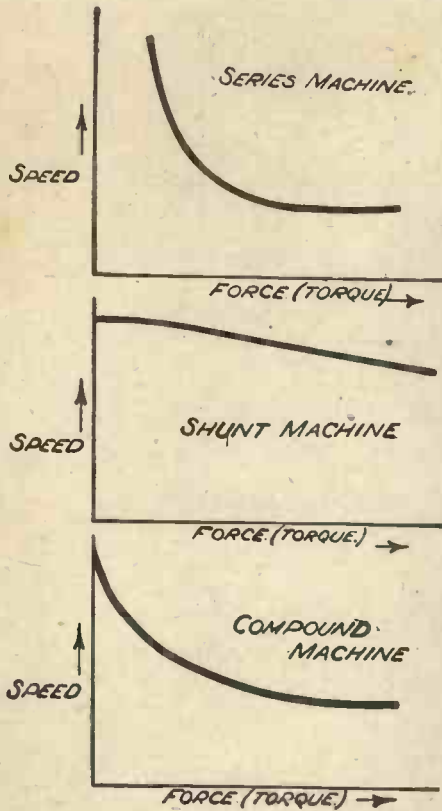

Fig. 6.—Characteristic performance curves of series, shunt- and compound-wound motors.

**The Efficiency of an Electric Motor**

This is very high when compared with other sources of power; but of the total electrical power supplied to the terminals of the motor, only a certain fraction is available as mechanical energy at the pulley, the remainder being lost in the motor. When a current flows through a wire, a heating of the wire takes place (depending on the current passing through the wire and the resistance of the wire), thus, since currents are flowing in the machine through circuits of definite resistance, heating of the machine takes place. In a machine with deep coils, that is, with many turns wound in layers upon each other, heat generated is not easily dissipated, and hence there is a marked temperature rise in the field coils. In the armature the heat is lost due to cooling currents set up by its rotation, but in large machines, ventilating ducts are cut in the armature to increase this effect. The greatest loss in armatures would be the eddy current loss, if the machines were made with solid armatures. Eddy currents are

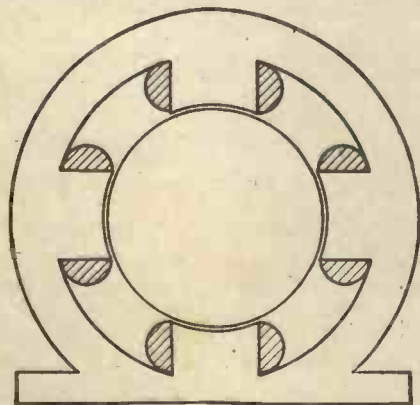
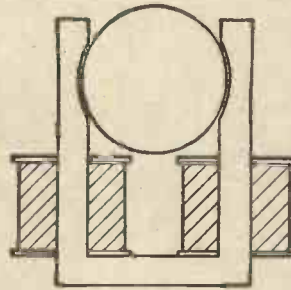

Fig. 11.—Four coils wound to produce consecutive north and south poles.

currents of electricity which are set up in the material and conductors of an armature. A solid armature revolving in a magnetic field acts as a conductor of very low resistance, thus very large currents will be induced in it, causing considerable power and heating losses. This difficulty is overcome by using laminations, therefore the voltages are only small and have high resistance circuits to travel. The laminations, core discs or stampings, as they are termed, are insulated from each other either by thin paper or shellac varnish, and should measure not more than 0.025 in. thick. The eddy current loss in the conductors becomes important only in machines with thick conductors, and is generally neglected in small motors. Some energy, depending on the current and the resistance of the contact, is lost in the heating of the commutator and brush gear, and to keep this low the areas must be as large as possible. Mechanical losses are due to the friction of the brushes, bearings and air, but as the brush pressure should be about 1½ lb. per square inch of contact area, an increase in this will naturally retard the machine. In all revolving parts there is friction losses in the bearings, and to minimise this, ball races are employed in small machines. Since the armature can be of considerable size, it naturally has a large air resistance which is most marked in turbine-driven machines. This may amount to 16 per cent. of the bearing losses.

Fig. 9.—Two coils wound in opposite directions.



**How a Motor Functions**

What happens when a motor is connected to a source of power? The switch is closed, and consequently there is a large rush of current until the machine has attained full speed. Consider a shunt motor with a resistance in the armature of 1 ohm, a huge current will pass, and even in the case of a model this may do considerable damage. Apply Ohm's Law to this machine when operated from the mains at a voltage of 230, and since  $\frac{\text{voltage}}{\text{current}} = \text{resistance}$ , a current of 230 amperes would flow. Although the armature would immediately start to revolve, some of the coils would probably burn out and all the fuses in the circuit would "blow"; hence the necessity for a starter. Most starters may be regarded as a variable resistance in series with the machine, therefore the current is kept at a reasonable value when the switch is first closed. The armature conductors cut lines of force just as in a dynamo, thus an E.M.F. is induced that tends to prevent the current flowing, which is known as the back E.M.F. This is the electromotive force or voltage. Consider a series-wound machine at rest; the switch is closed, and as there is no back E.M.F. a large current will flow until the machine is running quickly. If the machine is now loaded, the speed and E.M.F. drops, but as the applied voltage remains constant the current increases, and thus the motor is able to drive the load.

There are very few people who have the facilities for making a machine from their

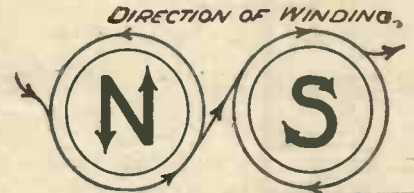

Fig. 7.—Direction of coil windings.

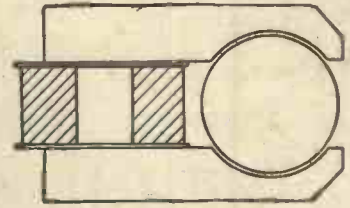

Fig. 8.—Single coil wound in only one direction.

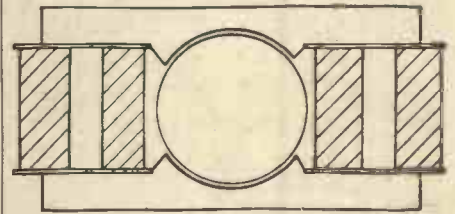

Fig. 10.—A different arrangement of two coils wound in opposite directions.

own designs, but there are a large number who could repair and rewind their own machines if they had sufficient information. The field magnets of small electric motors are wound to produce consecutive north and south poles. If a bar of iron is wrapped from end to end with insulated wire and the electro-magnet so formed connected to the terminals of a battery, a north and south pole are produced. When the magnet is bent into the shape of a horseshoe, the coil appears to be wound in opposite directions. If this is borne in mind when winding field magnets, mistakes will not be made. To remember this, consider Fig. 7. Some of the more common types of field magnet, with the direction of the coils, are shown in Fig. 8.

**Field Coil Insulation**

This is very important, and when possible the wire should be wound on a fibre former that can be slipped on to the pole pieces or field magnets. The winding space should be circular or square with well-rounded corners, and as long as possible, so that the heat generated will be easily dissipated from the surface of the windings. Former wound coils may be made in the lathe and the final layer should be put on a backing of brown

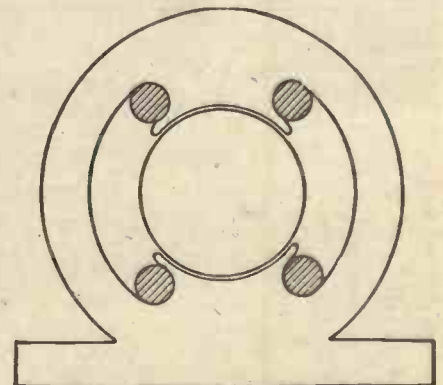

Fig. 12.—Two coils wound in the same direction.



# PRACTICAL EXPERIMENTS IN PHOTO-ELECTRICS

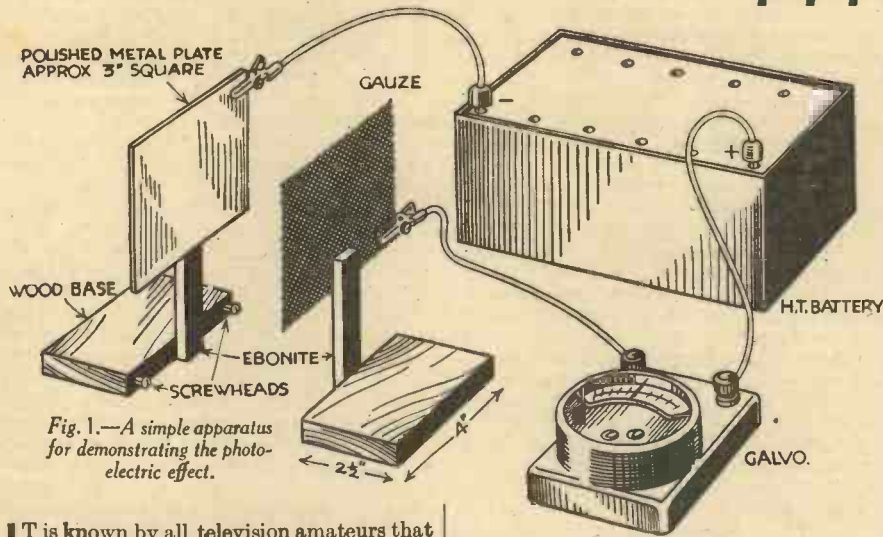

Fig. 1.—A simple apparatus for demonstrating the photo-electric effect.

It is known by all television amateurs that the modern photo-electric cell owes its origin to the discovery made in 1888 by Hallwachs, a German physicist, that areas of certain metals, when strongly illuminated by violet, or, better still, by ultra-violet rays, lose almost immediately a charge of negative electricity which has been previously imparted to them. This effect is usually known as the "Hallwachs effect."

In addition to the above, however, it was discovered also that an uncharged insulated metal plate is able to acquire a positive charge when ultra-violet rays fall upon it. Such phenomena were studied by a number of scientists and, eventually, they gave rise to a device of supreme practical importance—the photo-electric cell.

It is possible to the amateur to make a number of interesting experiments based upon the early observations of Hallwachs and others. Such experiments are easy to carry out and they are of value in view of the fact that they illustrate in a very definite and striking manner the fundamental principles of the photo-electric cell.

In the first of these experiments construct the apparatus shown in Fig. 1. It consists of two small wooden bases, approximately  $4 \times 2\frac{1}{2}$  in. in area. Each base has an ebonite upright. To one of these uprights is secured a piece of coarse wire gauze. To the other upright is fixed a metal plate, the plate being fastened by means of a lump of plasticine or a dab of sealing-wax placed at the back. The metal plate should be about  $3 \times 3\frac{1}{2}$  in. square, the area of wire gauze being about the same dimensions also.

### Preparing the Plates

A number of plates of different metals should be provided, such as plates of copper, zinc, sheet iron, tinned iron, aluminium and brass. It is absolutely essential that these plates should be brought to a high polish on one side. A mirror-like surface is not essential, but the plates should be rubbed over first with coarse and then with fine sandpaper (with the exception of the tinned iron) in order to expose a fresh and untarnished surface to the light action.

Connect a wire to the gauze and connect up the other end of the wire to one terminal of

a galvanometer or other current-indicating instrument, the more sensitive the better.

Next connect another wire to the metal plate and the other end of this wire to the negative terminal of a radio high-tension battery which should possess an E.M.F. of the order of 100 or 120 volts. The positive terminal of the H.T. battery is connected to the galvanometer, thus completing a circuit from metal plate to metal gauze.

Before making these connections be sure that all the apparatus (H.T. battery and galvanometer excepted) is perfectly dry. If you have any doubts upon the matter it is best to place the wooden stands supporting the metal plate and gauze for half an hour in a warm oven in order to drive off traces of moisture which would very probably ruin the experiments.

Having fixed up the apparatus as shown at Fig. 1 and described above, move the wire gauze assembly up to the metal plate so that the gauze faces squarely up to the

There are a number of simple and easily-performed photo-electric experiments which are able to offer many absorbing half-hours to the student. Such experiments are particularly those concerned with the underlying principles of the photo-electric cell.

plate and is separated from it by a space of about  $\frac{1}{8}$  or  $\frac{1}{4}$  in. (not more). On no account, however, must the gauze actually touch the plate, otherwise the H.T. battery circuit would be completed and the galvanometer probably ruined.

Note now the galvanometer reading. It will be seen that no current flows. Now take a few inches of magnesium ribbon and burn it in front of the metal gauze and at a distance of about 6 in. away from it. The burning magnesium will flood the metal plate with ultra-violet rays. Instantly the galvanometer needle will be deflected, showing that a current is passing. Moreover, as the burning magnesium ribbon is moved up to the wire gauze the galvanometer deflection will increase, whilst if the magnesium ribbon is withdrawn from the gauze the galvanometer needle will show a decreased deflection, thus proving that the current-generating property of the ultra-violet light is proportional to its intensity at the metal surface—a law which governs rigorously the functioning of all light-sensitive devices.

### The Effect on the Plates

Repeat the above experiment with the various metal plates. It will be found that a zinc plate gives the best result. After zinc comes aluminium. Copper, brass and tinned iron show a very considerably decreased effect and sometimes, if they are not highly polished, they do not show it at all.

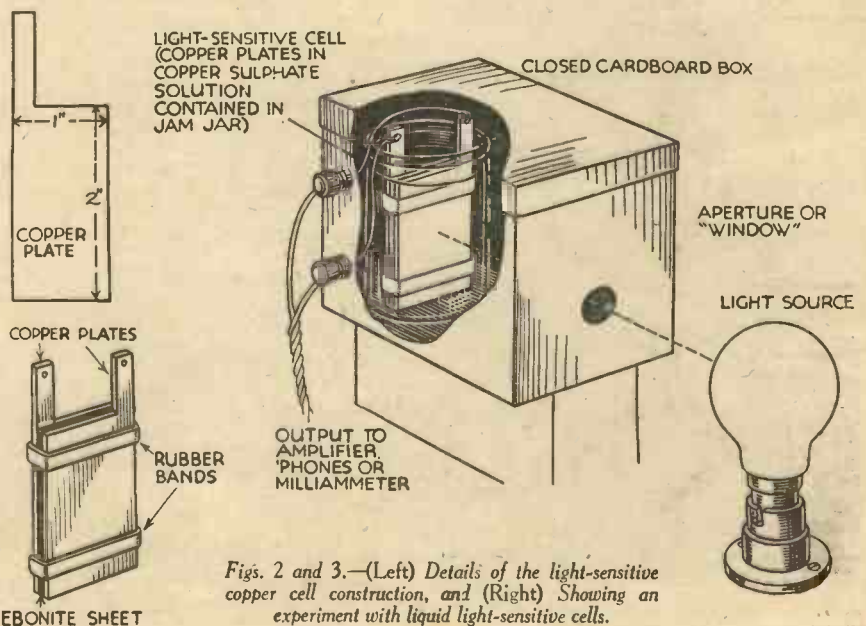

Figs. 2 and 3.—(Left) Details of the light-sensitive copper cell construction, and (Right) Showing an experiment with liquid light-sensitive cells.

What is the explanation of the above effect? It is not difficult to grasp. The metal plate, being connected up to the negative pole of the H.T. battery, is negatively charged. When the plate is acted upon by ultra-violet rays it loses a portion of its charge. Thus the equilibrium of the battery circuit is disturbed and a small current flows.

It will probably be found that any given metal plate will only show that the photo-electric effect in this manner a certain number of times—say, half a dozen times. After this it will undergo a species of "photo-electric fatigue." This is due to the slight tarnishing or surface oxidation undergone by the plate. If the plate is rubbed over thoroughly with fine sandpaper so as to expose a fresh surface, it will be found to show the photo-electric effect as well as ever.

The underlying cause of the photo-electric effect is readily grasped. When a light ray of a certain vibration-frequency—a ray of ultra-violet light, in the above case—falls upon a polished metal surface, it knocks away from one of the surface atoms one or more electrons, the electrons being shot off from the metal surface in a manner similar to that in which they are emitted from a heated valve filament, although less copiously. The H.T. battery simply supplies a "driving potential," the electrons being caught by the gauze screen, the circuit thus being completed.

The photo-electric effect is best shown by the alkali metals, potassium, sodium, rubidium and caesium. Such metals, although they enter into photo-electric cell construction, cannot be employed in the above experiments because, in contact with air the surfaces instantly become covered with a layer of oxide. In photo-electric cells such metals remain bright indefinitely on account of the absence of air in the vacuum cells.

Besides metal plates certain crystals are light-sensitive and can be made use of in the above experiments. If, for instance, instead of a polished zinc or aluminium plate we employ a crystal of galena, the well-

known wireless rectifying crystal of former days or, better still, a piece of molybdenite the same effect will usually be obtained with the apparatus described. Not all galena crystals are sensitive in this manner. Their sensitivity depends upon some unknown factor. Hence, the experimenter who has a quantity of galena crystals available will have to play the game of trial and error with them until he hits upon a crystal which displays strongly the photo-electric effect.

Other crystals which are similarly photo-electric are chalcopyrite and iron pyrites, both of which were formerly well-known as radio rectifiers.

#### Liquid Light-sensitive Cells

These cells provide a large field for amateur experimentation. One of the simplest cells of this type is seen at Fig. 2. It comprises two copper sheets, approximately  $2 \times 1$  in., which are cut with an attached lug, to which a connection may be made. The copper sheets should be well cleaned by rubbing them over with strong soda solution, then by rubbing them with coarse and, finally, with fine sandpaper. A suitably-sized piece of ebonite sheet separates the copper plates which are attached to it by means of two rubber bands.

Make up a 1 per cent. solution of copper sulphate (about 5 grains of copper sulphate in an ounce of water is the right proportion) and stand the copper plates in a vessel containing this solution. Preferably, a three or four days' immersion should be allowed and the immersion should be carried out in the dark.

After a few days the cell will have "formed." A fine coating of copper oxide will be present on the surface of the plates, this thin film being light-sensitive.

Now obtain a cardboard box sufficiently large enough to contain the cell. Make an aperture in the side of the box so that light passing through this "window" may fall upon one of the copper plates of the cell, the other being unilluminated. Connect leads from the copper plates to a pair of headphones or to the input terminals of a

radio amplifier equipped with a loud speaker.

On holding a bright light-source near to the "window" of the box and interrupting the light more or less rapidly by jerking a sheet of cardboard up and down in the path of the light rays, a series of clicks will be heard in the phones or loud speaker, these clicks being generated by pulses of current from the light-sensitive cell.

A cardboard disc provided with radial slots will, when revolved in the path of the light rays, give rise to a humming noise in the phones of speaker. Also, if by any chance a miniature arc-light can be obtained, it will be possible to listen-in to the irregular pulsations of current passing through the arc.

Needless to say, all these effects may be studied by substituting a sensitive micro-ammeter in the external circuit of the cell in place of the phones or radio amplifier. Micro-ammeters, that is to say, instruments which read down to a few millionths of an ampere, are costly articles, however, and not many experimenters possess them.

For purposes of reference, however, it may be convenient to state that a copper light-sensitive cell constructed on the lines indicated above will under the illumination of a 100 candle-power electric bulb placed about 6 or 8 in. away from it, deliver up a current of about 80 micro-amps, which current, incidentally, is a large one compared with the minute currents generated by the vacuum and gas-filled types of photo-electric cells.

Other types of liquid light-sensitive cells can be constructed. Nickel plates can be immersed and "formed" in a solution of nickel sulphate, silver plates in silver nitrate solution, aluminium plates in aluminium sulphate solution and so on. Be careful, however, in all experiments to have the plates perfectly clean before they are immersed in the solution for the "forming" of the cell. Allow at least three days—better, often a week—for the cell to form. Upon such details of plate-surfacing and plate-forming depends entirely the whole success of experiments in connection with liquid light-sensitive cells.

## AN INTERESTING MODEL OF THE "ROYAL SCOT" LOCOMOTIVE

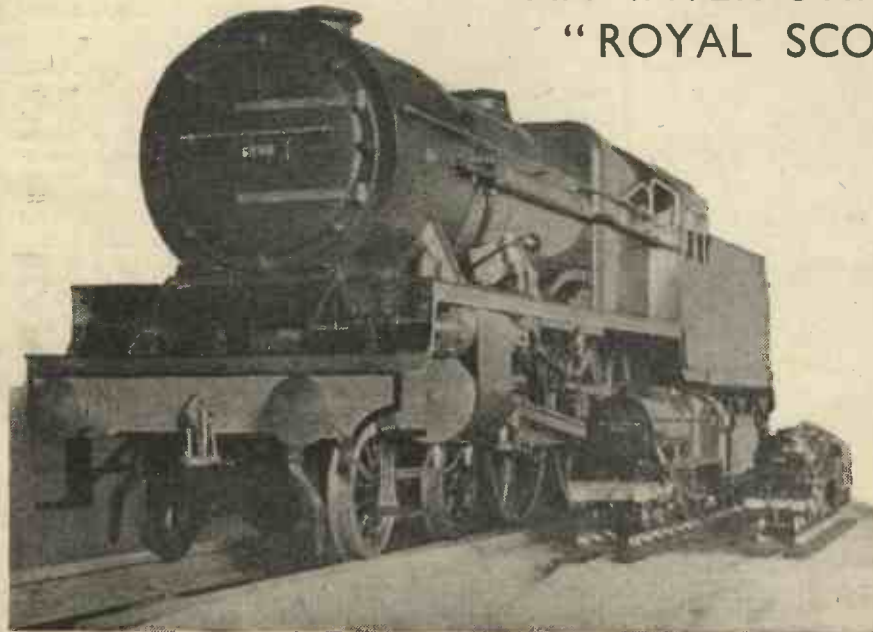

Showing models of the "Royal Scot" built to three different scales.

**B**ASSETT-LOWKE LTD. have just completed a magnificent model of the "Royal Scot" built to a scale of  $1\frac{1}{4}$  in. to the foot,  $7\frac{1}{4}$  gauge, and over 8 ft. long. It has recently been on show at their London Branch, 112 High Holborn, W.C.1, where it has been much admired by connoisseurs of high-class locomotive construction.

It burns solid fuel, has piston valve cylinders, full Walschaert's valve gear and mechanical lubrication. The boiler is fed by two injectors and also steam pump mounted on footplate. The photographs reproduced herewith show this magnificent model together with a gauge 1 model in steam and a gauge "O" electric "Royal Scot," all built throughout at Northampton.

Bassett-Lowke have just issued their new Model Railway Catalogue, Section "A," which contains particulars of all these models, and this will be sent post free to all our readers, and we should recommend them to send for a copy price 6d. from Northampton, or call for one at their London or Manchester Branch.

# A 4<sup>3</sup>/<sub>4</sub>-IN. GAUGE GARDEN RAILWAY LOCOMOTIVE. PART IV

By E. W. TWINING

MENTIONED in my articles on the  $\frac{1}{2}$ -in. scale G.W.R. "Castle" class locomotive the alternative methods of making all riveted seams steam-tight, but the boiler for this  $\frac{3}{4}$ -in. gauge engine is too large to permit of silver soldering, and the plates and flanges before riveting must either be tinned and have soft solder run in after riveting is completed, or dependence must be put upon caulking, as is the practice with full-size boilers. In this case, however, we are dealing with copper and not steel, and it will be rather risky to rely upon caulking. It is understood, of course, that no dependence for strength is to be put on the use of solder, and the riveting should be done as thoroughly as if no solder were going to be used. The whole of the plate work will be completed first, inner and outer fire-boxes all riveted up, the tube plates having the holes drilled and reamed out for the tubes to make a perfectly tight fit. The tubes are then passed into place and expanded at both ends with a tapered steel drift and beaded over, the whole boiler then being heated with a blow pipe or blow lamp, and the solder run into the seams.

### The Steam Pipe

The steam pipe from the regulator in the dome to the front tube plate must be introduced before all the flue-tubes, otherwise it will be impossible to get it in. The whole regulator, complete on the pipe, can be fixed in the tube plate before it is riveted in the boiler shell or the steam pipe can be passed down through the dome opening and expanded in the tube plate after riveting. The girder-stays on the firebox crown must, of course, be fixed and bolted up before the box is secured in the boiler.

### Firebox Stays

All the screwed rod-stays will, of course, be put in after the box is riveted in place. The holes for the stays will be drilled through both plates at one operation, and each of the holes in the inner and outer boxes will also be tapped together. The copper rod should be screwed so that the thread, when finished, is a fairly tight fit in the tapped holes. The pieces of rod for each stay should not be cut off to the required length before being screwed into the plates. It is better to thread a long length of rod, file the inner end square, screw the rod into both plates and then saw off nearly flush with the outer firebox plate; file the rod square again and screw in the next stay, and so on until all are in place. The ends of the stays are riveted over to make them steam-tight, and this riveting will be facilitated if the filed end of the rod

is slightly countersunk by having just the point of a drill run into the squared surface. After the outer ends of the stays are cut off they also are filed flat and countersunk with a drill. When riveting over the raised edges above the countersink the ball end of a light hammer is used, the opposite end of the stay being supported on a bit of steel held in the vice with a rounded or slightly pointed end on which the countersink will rest. The resulting shape of the stay after riveting is shown in the cross section through the firebox in Fig. 12 and also in the longitudinal section (Fig. 7). If this riveting is properly done the stays

should be steam-tight without the need for soldering.

### Footplate End of the Engine

The general-arrangement drawings of the engine are completed with the exception of one view. This is an elevation of the rear end showing all the driver's fittings and is given in Fig. 13. It is impossible to fix the steam valves for the injectors at a point higher up on the back plate than the position in which they are shown. This is not really sufficiently high to ensure no water entering the valves and passing to the injectors, and it will be advisable, therefore, to insert copper pipes in the screwed holes in the plate and let these pipes turn upwards inside the boiler so that the steam shall be taken from as near the top of the boiler and as far above the water level as possible. It will be best to put these pipes into the back plate before the plate is riveted in place. The pipes will need to be large enough for the threaded ends of the valves to screw inside them.

Another way to do the job, of course, would be to solder smaller diameter pipes into the valve itself and screw the valves into the back plate before the plate is fixed.

I have not previously mentioned, although the fact is noted at the side of the firebox cross section (Fig. 12), that the two injectors are of a pattern and make known as the "Cert." These injectors, as the name implies, are absolutely reliable, since they will pick up and work instantly under a considerable range of pressures. The great advantage about them is that they contain a check valve at the water delivery end. This is provided in order to ensure that should the main check valve of the boiler leak the hot water passing back to the injector shall not make it sufficiently hot to prevent it working. The great thing to ensure an injector starting quickly is to keep it as cold as possible.

It will be noticed that the feed-water pipes, which couple up to the tender, are above the footplate. In this position it is much easier to get access to the unions when connecting or disconnecting the tender.

The blower pipe on the right-hand side of the boiler is carried along inside the lagging and enters the smoke-box through a hole in the heavy jointing ring, to which the front end of the boiler barrel is riveted. In Fig. 7 I have shown the end of the blower pipe of rather large diameter. The end should really be contracted to form a jet or else have a brass plug

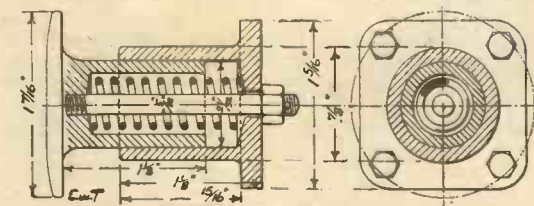
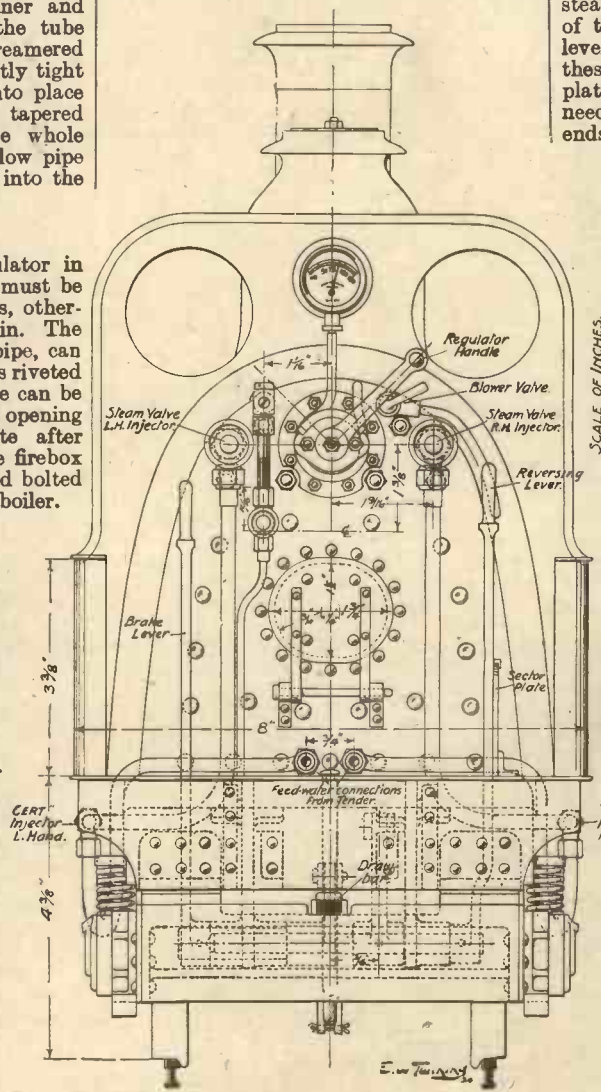

Figs. 13, 14 and 15.—(Above) Elevation of the footplate end of the engine. (Right) Details of the brake and reversing lever shafts under the footplate. (Left) Details of the buffer.

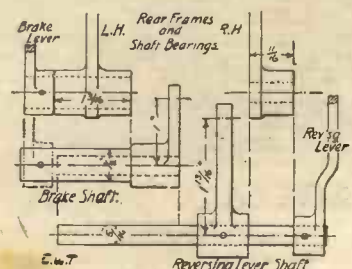

silver-soldered in the pipe, the plug having a hole about  $\frac{1}{2}$  in. diameter drilled in it. As already mentioned, the brake lever shaft is hollow and fits over the reversing lever shaft. This description, however, may not make matters very clear. Both the shafts are shown in Fig. 13, but here again some explanation may be necessary, and so I have appended a detail drawing in Fig. 14, in which I have drawn the several components separated. No details have been given hitherto of the buffers, and a sectional view of one of these forms the subject of Fig. 15.

**The Tender**

It merely remains for me to give a drawing of a tender suitable for the engine. Did space permit I would have given alternative ideas regarding this—one, a design for a

the horizontal plate extending the whole length of the tender. The tender body can be either of very thick tinned-steel plate, well and strongly soldered together with angles, or of planished plate, in which latter case jointing will have to be by riveting.

**The Water Tank**

In either case I have thought it advisable to make the water tank a separate unit, which can be dropped into position after the tender is finished. This tank should be made of either brass or copper. Attention is called to the fact that the back of the tank is curved from top to bottom, this being necessary in order to drop the tank into place. In the horizontal steel plate referred to either one large or two small holes must be cut over the centre axle and another, or another pair, near the front end

overhang sufficiently wide for a strip of wood projecting downwards to keep the seat in position. The simplest form of foot-rest, which should be removable, is a plain strip of oak with two notches sawn in it to engage with the lower edge of the frame plate in the opening immediately in front of the leading wheels. The fuel space, or coal bunker, should have a sloping plate at its front edge to carry the bottom of the bunker over the feed-water pipes.

**Stoking Arrangement**

The view of the back of the firebox in Fig. 13 shows a properly designed door. This feature is, however, to some extent, ornamental, since I suggest that the easiest way in which stoking can be performed when driving the engine is to have a coal chute, or hopper, one end of which is

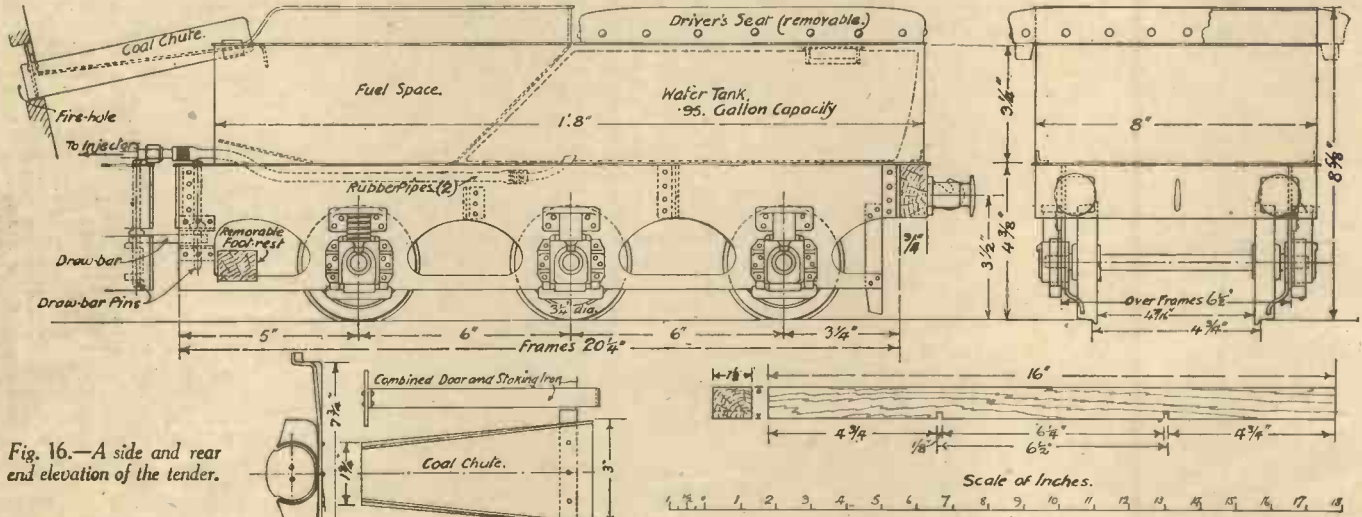

Fig. 16.—A side and rear end elevation of the tender.

more proportionate tender, on which the driver would not ride, and the other a low-sided vehicle with a seat and foot-rest to accommodate the driver. A tender of this second kind is shown in Fig. 16. With a tender which is more or less a scale model the driver would have to ride on a truck behind the tender, in which case he would have to fit detachable rods to all the important fittings on the engine so as to enable him to reach, through these rods, all the controls. Perhaps, after all, the most satisfactory way is to build a tender strong enough to be ridden upon.

By referring to Fig. 1 it will be seen that the wheels, axle boxes, horns, springs, etc., for this tender are exactly the same size as the corresponding parts on the radial truck of the engine and can be cast from the same patterns. The frames are of the same thickness as those of the engine, as is also

of the tender over the removable foot-rest. These holes are to allow of the passage of the water pipes. In the under side of the tank two short, curved, copper pipes are soldered. The connection from these to the unions, which couple up to the engine, can very well be by two pieces of strong rubber pipe. As these pipes are subject to no other disturbing force than the suction from the injectors, rubber will serve the purpose here perfectly. At the front end of the tender two stretcher plates will be riveted between the frames. These will be drilled at the centre to take the tender draw-bar pin, which will be exactly like that on the engine.

The driver's seat is a piece of board, deal or any other suitable wood, padded on the top side with felt and covered with cloth, leather or Rexine, as may be preferred. The width of it should be slightly greater than the tender body so as to have an

inserted in the fire hole, the hinged door in this case being lowered to the engine foot-plate. The other end of the chute, or hopper, will rest upon the tender body by means of a strip of steel plate riveted to it, as shown in the separate sketch in Fig. 16. For closing the fire hole temporarily, when stoking is not being done, a steel plate, roughly oval and cut to the shape shown, is riveted to another bent strip of steel, which strip forms a handle. This acts not only as a door, but as a stoking iron, the coal being dropped into the chute by hand and pushed into the firebox with the tool. This whole arrangement will be found much more convenient. Having completed the description of the building of the engine and tender, the next and concluding article will deal with suitable permanent way upon which may run the locomotive and passenger trucks.

its own interests. When the changes were first introduced they were violently opposed by the merchants and the captains, and the illiterate divers regarded them with sullen indifference, having been persuaded that they would not benefit by them. The Moslem leaders supported the Sheikh, and their assistance contributed considerably towards carrying out the reforms. It has taken some years for the divers to appreciate the improved conditions, but now they realise that they are far better off to-day than they were in the past.

The buying and selling of pearls are done in the neighbourhood of certain coffee shops in the two chief towns of Bahrein, Manama and Muharraq, and in the handsome offices and houses of the big pearl merchants who come every season, usually travelling by

**PEARL DIVING**

(Continued from page 165).

air, from Paris, India, Persia, and Arabia. Though the climate of the Gulf is notorious, living conditions in Bahrein have much improved lately, especially since the introduction of electricity. Manama, the capital of Bahrein, is a pleasant town, with clean bazaars, wide roads, and shady public gardens. It is the merchants who make the big profits, not the captains and the divers. The famous pearl which was sold for £15,000 was bought from the boat for about £6,000. Most of the sales are transacted through brokers, who go from buyer to buyer, carrying their pearls knotted in a little twist of scarlet twill.

A stranger seeing two Arab dealers bargaining would suppose that they were fighting; they tear their headcloths from their heads, seize each other by the beard, and often one of them rushes frantically from the room, but returns a moment later, to make another offer. If many people are present and two men do not want their prices to be heard, they adopt a different method. Each places his hand under a cloth, and they indicate the amounts by signs; a grasp of the whole hand means 1,000, a touch on the palm means 500, a pressure of one finger means 100, and a pinch on the joint of a finger represents 10.

[The above article recently appeared in The Times, to which paper we give full acknowledgment.]



# FIVE-MINUTE AMUSEMENTS

Some Interesting Novelties and Tricks for the Christmas Party.

**A**T this time of the year when everybody is thinking of parties, etc., a little thought and foresight will go a long way towards making an affair of this kind smooth-running and successful if you are able to devise a number of interesting tricks to keep the company amused. The following tricks will be found quite simple to perform and only apparatus which can be found in any household is used.

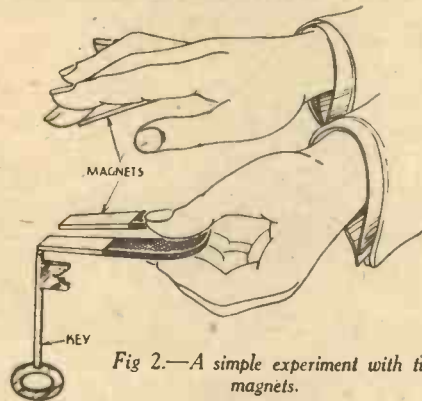

Fig. 2.—A simple experiment with two magnets.

### The Electrified Walking-stick

The performer should carefully balance a walking-stick on the back of a chair as shown in Fig. 1 and then ask anyone who may be present to come forward and without touching the stick or chair to remove the stick. It should be pointed out that blowing on the stick or stamping or doing anything that will cause any vibration to the floor, chair, etc., is forbidden. When the person finds he is unable to remove the stick in the desired manner, produce a piece of brown paper and a clothes brush, and having electrified the paper by rubbing it briskly with the brush a number of times, hold it fairly close to either end of the stick, thus causing it to swing round, following the paper and finally falling off.

### The Ping-Pong Race

The apparatus required for this game are two ping-pong balls, two pieces of brown paper, and two clothes brushes. Place the two balls on a table, electrify the paper by the process stated pre-

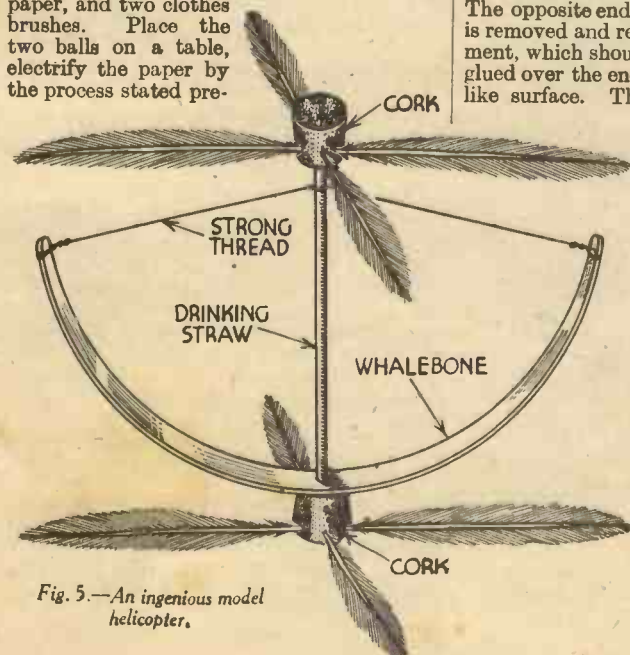

Fig. 5.—An ingenious model helicopter.

viously, and hold it near the ball so that it is attracted towards it. By drawing the paper along in front of the ball, the ball will be made to move the whole length of the table. Thus, when played by two players, an amusing race will result, the object being to see who can make his ball arrive at the end of the table first.

### An Experiment with Magnetism

Obtain two small magnets and a key or other metal object. This trick depends on the fact that like poles repel one another and unlike poles attract. Hang the key from the end of one of the magnets as shown in Fig. 2, and slide the other along it. The poles will then come together and the key fall. When demonstrating this trick to an audience, conceal the second magnet in the hand as shown.

### A Simple Match Trick

Obtain a box of safety matches and arrange the box and matches as shown in Fig. 3. As will be seen, the middle horizontal match is firmly gripped between two other matches which are fitted into the top of the box. Light the top match in the centre and the problem which the audience has to solve is which of the supporting matches will light first. Try it and see what happens!



Fig. 3.—Which of the supporting matches will light first?

### Aerial Spinners or Vortex Rings

In the illustration Fig. 4 B is an oblong box measuring 12 x

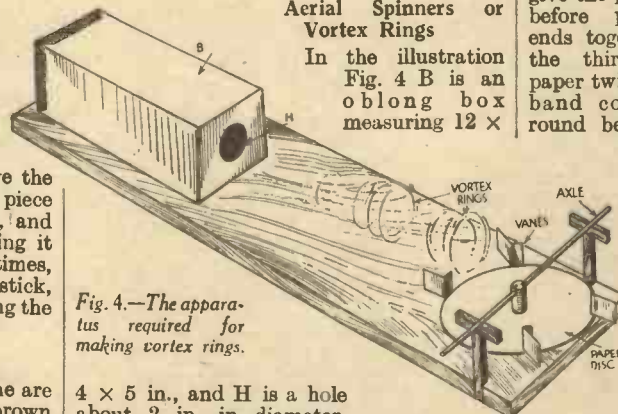

Fig. 4.—The apparatus required for making vortex rings.

4 x 5 in., and H is a hole about 2 in. in diameter. The opposite end of the box is removed and replaced by a sheet of parchment, which should be tightly stretched and glued over the end so as to present a drum-like surface. The smoke for making the rings is produced by soaking two pieces of blotting paper in strong hydraulic acid and ammonia respectively. They should then be placed in the box, pushing the first-named up to the far end of the box and the other to the middle. They must not touch one another. By smartly tapping the parchment at the back of the box, vortex rings can be shot out as desired. A candle a yard or two away can be snuffed out with one of these rings, or they can be made to rebound from one another like rubber balls. The little paper wheel which is shown in

the illustration can also be made to rotate by means of the rings.

### A Novel Flying Machine

The machine shown in Fig 5 shows a model of the earliest heavier-than-air flying machine constructed by Sir George Cayley in 1796. All that is required to construct this model helicopter is eight feathers, two corks, a piece of light tubing, such as a drinking straw, a piece of whale bone, and a piece of thread. Note that the two sets of feathers must be reversed so that they both lift the machine. They are set at a slight angle, each set forming a four-bladed propeller.

### The Manhattan Bands

Obtain four strips of paper about 5 ft. to 6 ft. long and about an inch wide, and prepare them in the following manner. Make the first strip of paper into an ordinary band by gluing the two ends together as shown in Fig. 6, and for the second give the paper a twist before pasting the ends together. For the third strip of paper twist the paper band completely round before joining

the ends (see Fig. 6). With a pair of scissors cut each of the three bands down the middle and you will obtain the results which are shown beneath the bands in Fig. 6.

### A Trick with Scissors

Obtain a fairly large pair of scissors, and hang the loops on your little fingers with the palms of the hands facing outward. The scissors should then be swung upwards and over towards you, without letting them slip off your fingers, at the same time shutting your fists and bringing them together, knuckles touching and the backs of the hands outwards. Now try and complete

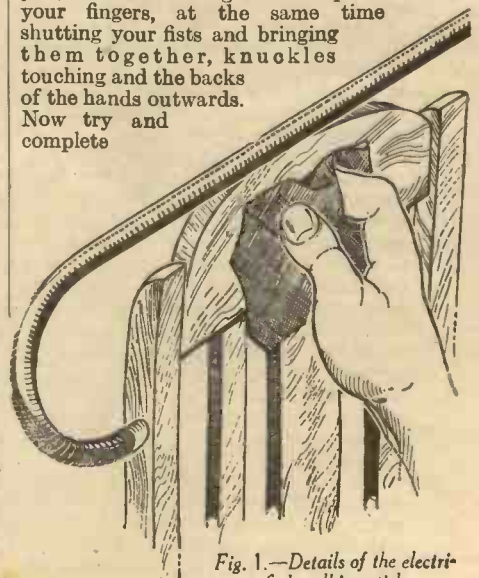

Fig. 1.—Details of the electrified walking-stick.

this manoeuvre with the scissors pointing away from you. Until you know the secret it seems impossible to end up in any other way than with the scissors pointing towards you or tied up in your fingers.

To do this simple little trick successfully you should let the scissors slip down your fingers to the last joint, before swinging them over. When you have done this let the loops of the scissors lie flat against your palms, with the tips of the fingers inside, and then turn your knuckles in, to meet (see Fig. 7).

**A Weighty Problem**

This is less of a trick than an experiment in physics, but it makes perfectly good drawing-room magic. Obtain a board

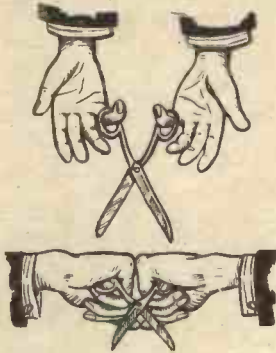

Fig. 7.—An explanation of the scissors problem.

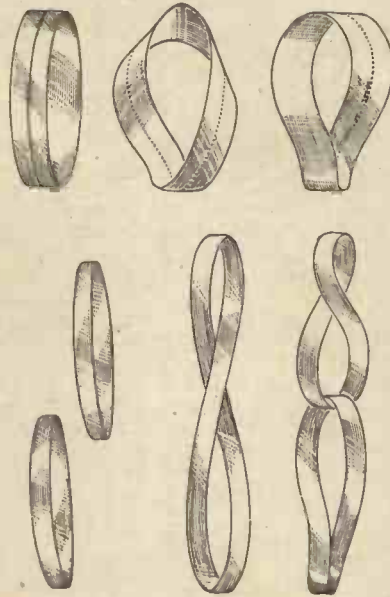

Fig. 6.—Details for making the manhattan bands.

about 3 ft. long and not too wide, a newspaper, and a sturdy table. Place the board on the table so that a third of its length projects over the edge, unfold the paper and

place it over the board to cover the part that rests on the table (see Fig. 8). Now press down on the projecting piece of board and the other end will rise easily enough, the paper making no difference. But ask someone to knock the board down with a blow of the fist. If he is discreet he will refuse to try, but if he does, no matter how hard the blow, the board will be unmovable, provided the blow is sharp and sudden. The explanation is atmospheric pressure. If the blow is sudden there is no time for the air to rush beneath the paper and board to equalise the pressure on the upper surface. As the pressure (14 lbs. to the square inch) on a single page of a daily paper is nearly 3 tons, the person who tries to raise it with a blow of his fist is not likely to succeed.

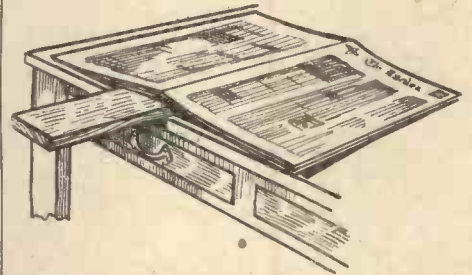

Fig. 8.—Details of the board and paper.

**S**OME remarkable reports have come to hand, recently, of long-range wireless reception between British air-liners and ground stations, and also between air-liners in flight.

The other day, for example, an amateur operator residing at Victoria West, Cape Province, South Africa, picked up messages sent out by the air-liner "Astræa," of Imperial Airways, when that machine was flying between Alor Star and Singapore, in Malaya. The distance between the aircraft in flight and the station picking up the message was approximately 5,200 miles.

**Signals from Air-liners**

The signals from the air-liner, which were routine messages on a short wavelength, transmitted while the machine was making a night flight, were received so well by the amateur at Victoria West that they came through at loud-speaker strength. Such long-distance reception is all the more remarkable when the fact is taken into consideration that the air-liner's power output is only 60 watts. Not long ago, while one of the aircraft on the Africa air mail was flying near Mpika, its operator got into wireless touch with another aircraft on the same route which, at the time, was flying at a point 2,000 miles distant, communication being maintained for several minutes without fading or interference. On another occasion, while an Imperial Airways machine was making an aerodrome survey along the route from England to Australia, its operator established communication with the Sydney wireless station at a time when the aircraft was in flight at a point over 5,000 miles from that city.

**Over the White Nile**

Another similar instance occurred while tests were being made with an improved type of short-range wireless apparatus: a machine while flying above the White Nile, between Juba and Kampala, managing to

**WONDERS OF LONG-RANGE WIRELESS**

establish communication over a distance of 4,000 miles with a station in England. During the same trials one of the operators, while over Central Africa, picked up and could hear quite plainly a news broadcast from a station at Miami, Florida. Long-range contacts were also established with stations in Germany and Italy; while Cairo received short-wave messages, without any

fading, from a machine more than 1,000 miles away, flying southward towards Cape Town.

**The Derby Result**

As yet another example of such long-range reception the fact may be mentioned that the result of this year's Derby was picked up by the operator in an Imperial Airways liner when the machine was flying between Baghdad and Basra. He communicated it at once to the passengers who, although they were at the moment high above the desert, thus became aware of what had won the race within a minute or so of the finish on Epsom Downs.



Wireless receivers being loaded on to an Imperial Airways Aeroplane at Croydon recently for dispatch to France.



A postcard to Guaranteed Tools Ltd., 12/13 Chiswell Street, London, E.C.1, will bring you full details of the G.T.L. Tool Chest and Home Repairing Outfit—the most complete set of fine Sheffield tools and equipment for the home handyman. [100.]

**For Draughtsmen**

It is not easy nowadays to improve upon the modern draughtsman's equipment, but the drawing kit shown herewith will not only prove decidedly practical and useful, but shows definite progress in the methods employed for recording sketches, and drawings of all types. The board itself is bounded on the bottom and left-hand side by two raised straight edges, firmly fixed at an exact right angle, and divided in inches and one-sixteenths, or metric scale. The paper on which the drawing is to be made is firmly attached to board, in the form of a pad, by two interscrews at the top. These interscrews are quickly loosened by means of the edge of a coin to allow the pad to be renewed or exchanged for one of tracing cloth or another type of paper, etc. This obviates the use of drawing pins, and avoids loss of time in fixing a new sheet of paper to the board. Only one moving implement is required for drawing both horizontal and vertical lines to the full width and length of the paper. This is accomplished by sliding the L-square along one or other of the two fixed straight edges.

A Review of the Latest Devices for the Amateur Mechanic. The address of the Makers of the Items mentioned can be had on application to the Editor. Please quote the number at the end of the paragraph.

**A Three-in-One Machine**

THE ingenious little machine shown at the top of this column works as a motor, dynamo or shocking coil. It is finished in best glossy enamel, and the gears are well made, and do not lock. The set is sold complete with bulb and handles, and full instructions are supplied. This novel little

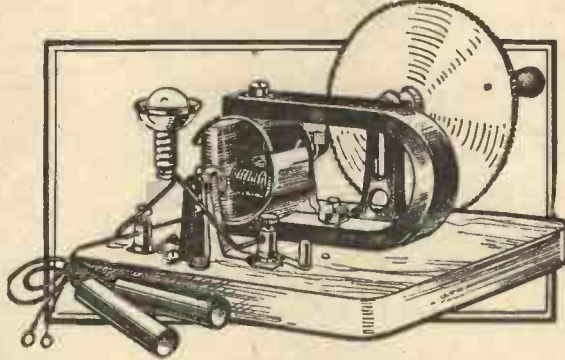

An ingenious three-in-one machine which works as a dynamo, motor or shocking coil.

machine measures 5½ in. × 4 in. × 3½ in., and sells at the moderate price of 10s. [98.]

**"Unique" Slide Rules**

THE use of the slide rule is slowly extending. It is no exaggeration to say that every person who makes calculations of any sort should be familiar with this valuable time-saver, and it is truly amazing that so many to whom a slide rule would be invaluable are unacquainted with it.

There seems to be an ineradicable impression that the slide rule is difficult to use and that a technical education is essential. There can be no greater mistake. Anyone who can work in the decimal system—and this surely means nearly all who make calculations—can learn to use a slide rule in half an hour and become proficient after quite a short time.

The "unique" slide rule illustrated in the second column has played a part in increasing the number of users of this instrument. It has been on the market for years and has therefore stood the supreme test of time. The manufacturers tell us that readers of PRACTICAL MECHANICS in all parts of the British Empire buy "Unique" rules which are equal in utility to instruments costing four or five times the modest prices asked. [99.]

A second moving implement in the form of a 45-60-75 degree triangle enables lines, by employing the three angles, to be drawn at 15-degree intervals throughout the circle with equal ease and rapidity. For intervening angles an ordinary protractor can also be used.



The "Unique" slide rule.

Attached to the board is a rigid flap cover which is provided with a series of packets securely to hold the L-square, triangle, pencils, compasses, etc. (these in turn being protected with a further waterproof cloth flap. This cover, when folded across the board, is fastened by means of press studs, so that a complete and compact outfit for recording all types of drawings is contained and adequately protected, in a cloth-covered case. In addition a strong waterproof satchel is provided as an extra to facilitate carrying of the block and protector against climatic conditions. It costs 15s. [101.]

(Continued on page 195.)

**A Complete Outfit of Tools**

HOW often you hear people say, "Yes, I'd tackle the job myself if only I had the tools"—perhaps they're referring to furniture or fixtures for the home, radio cabinets for friends, or one of the hundred odd jobs about the home and garden—but they must pay others to do the job because they lack proper equipment.

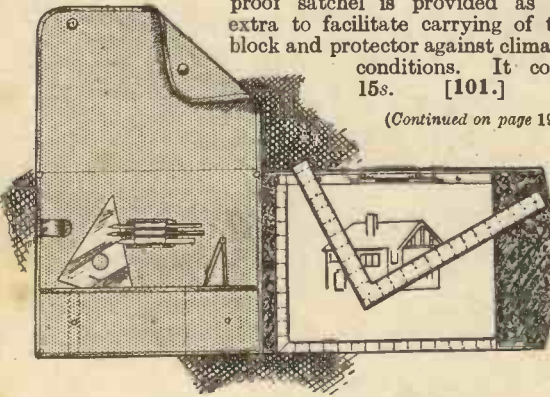

A complete portable draughtsman's kit.

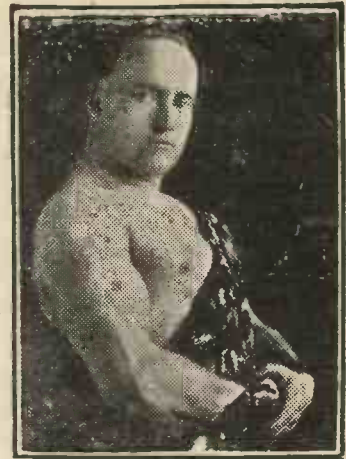

**80,000 PEOPLE HAVE READ THIS AMAZING BOOK!**



PAST the 80,000 mark, and still going strong! If you would read something that would stir your very vitals—if you would learn something the like of which you had never even dreamed! Then send for this book and read how YOU can charge your body full of vitality, add five inches to your chest, acquire the power of battering rams in your arms, and develop a neck and legs like pillars! It's all here in this very book explained in detail, and you'll agree, like thousands of others have, that it's the most amazing book you have ever seen.

**WATCH THEM TURN AROUND!**

NOTICE how every woman prefers the fellow who carries himself with head up. Notice how the broad-shouldered man always gets their eye. They want a dependable he-man, when they make their choice—one who can protect them. AND YOU CAN BE THAT MAN. Remember, I do not only promise it, I GUARANTEE IT. Now, don't put it off a minute. Get going to new happiness, and real manhood, to-day!

**YOURS FREE IF YOU SEND NOW!**

THIS month, to every reader of this paper who is interested—here's my offer: To prove to you what I have said about "The Secrets of Muscular Strength—and How to Acquire It" I am going to give ONE FREE ISSUE providing you make application at once. This book has been the cause of changing the lives of thousands of men. I have received countless thousands of wonderful letters and photographs of actual transformation of men who never thought they could acquire strength and development! Make me PROVE these assertions to you by sending for your copy this minute, not to-morrow, you may be too late, but to-day—NOW! Are you ready? Let's go!

-----RIP OUT—POST NOW-----

ALFRED J. BRITON (Dept. P),  
8 Broadway, London, W.6.

Please send me absolutely FREE a copy of your latest book, "The Secrets of Muscular Strength—and How To Acquire It."

NAME.....

ADDRESS.....

# The LATEST Novelties

The address of the makers of any device described below will be sent on application to the Editor, PRACTICAL MECHANICS 8-11, Southampton St., Strand, W.C. 2. Quote number at end of paragraph.

### Morse Writing Apparatus

THOSE readers who like experimenting with electrical apparatus will no doubt be interested in the morse inker shown in the sketch below. This piece of apparatus is accurately designed and of best finish in

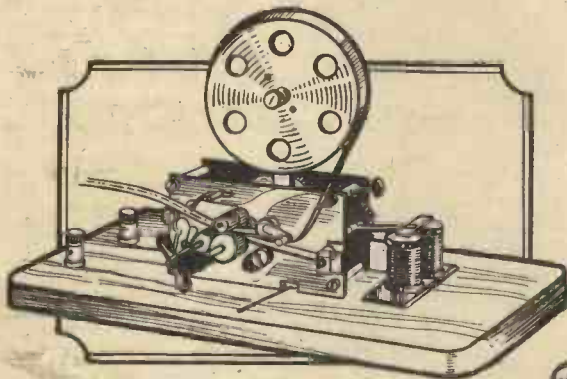

Details of the morse inker described in the text.

polished brass. The motor is of first-class clockwork, and the set is capable of working with a two-valve set. It is obtainable complete with paper roll, inking disc, key, and full instructions for working. A small taper is also provided, and for those readers who desire to take up morse it is an excellent practice machine. It costs 28s. [92.]

### Spotlights, Torches, etc.

THE photograph at the bottom of this page shows a fine range of torches, spotlights, etc., which are always useful to the handyman. Of special mention is the inspection headlamp, which is fitted to the head by means of an elastic band. This has the advantage of leaving both hands free to do whatever work is needed. It is fitted with a nickel battery-container that can quickly be attached to a button, pocket or belt. The cost is 7s. 6d., and a convenient case covered in black leather cloth, lined



A fine range of torches and flashlights

with velveteen, can also be obtained at 3s. 6d. Another useful light is the "snap-lite," which can be carried in the waistcoat pocket. This is a very tiny light, so designed that a slight pressure on the reflector lights it automatically. It costs 1s. 6d. [93.]

### The "Anglepoise" Table Mirror

THE "anglepoise" mirror shown herewith is extremely novel and has many uses, chief of these being that it is a definite aid to solving shaving problems. No matter how difficult the light, this mirror can be adjusted to make the very best of it. It is made of 1/4-in. plate-

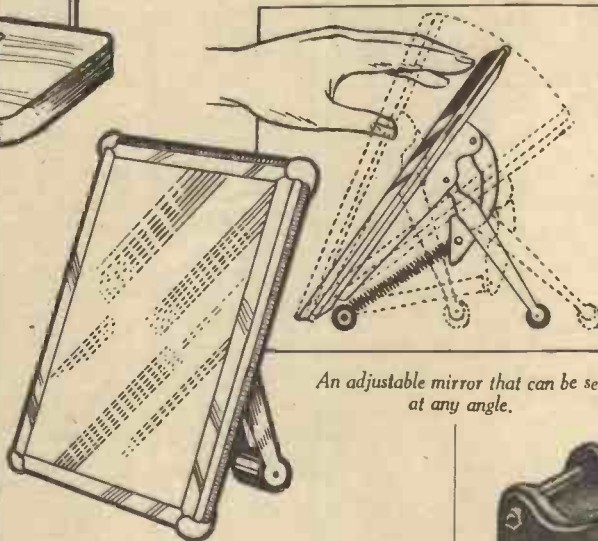

An adjustable mirror that can be set at any angle.

glass, 10 in. x 7 in., bevelled and frameless, which is mounted upon a strong back available in several picturesque colours. The "anglepoise" action, which is of the utmost strength and neatness, is chromium-plated.

The mirror can stand at the very edge of the table even if glass covered and it will not slip off. Although it needs but a touch to adjust the angle, yet a blow will not knock it over. It is obtainable for 21s. [94.]

### Run your Models from the Mains

THE only way to get the utmost satisfaction with miniature locomotives or other similar working models is to run them from the mains. The transformer shown on this page enables you to run your models with maximum efficiency, at extremely low running costs and trouble-free operation. These transformers can be handled with perfect safety, their well-protected special output plugs and sockets ensuring perfect insulation. Encased in attractive finished black aluminium cast frames, it has output tappings of 6, 12 and 22 volts. The variable control gives voltage increases in one volt steps. The current output of the model is 3 amperes, thus allowing powerful model locomotives to be run at the same time as current is drawn for lighting the signal and track lamps. To obtain 6 volts, plug into the 0 and 6v. tappings; to obtain 12 volts, plug into the 0 and 12v. tappings, and to obtain 22 volts plug into the 12v. and 22v. tappings. The standard transformers are designed for use on A.C. mains 200-250 volt, 40-100 cycles. Special models are obtainable for 100-110-volt mains at no increase in price. It sells at the very moderate price of 27s. 6d. [95.]

### Point-operating Device

A SIMPLIFIED model of the actual point-operating device now in use on various railways is now on the market. After switching on the current from the signal cabin, the action is entirely automatic. The machine moves the switch



A transformer suitable for running models from the mains.

over and then switches off the current completely, leaving the switch firmly locked. Suitable for 0-gauge, it costs £3 10s. [96.]

**EVERY CIRCUIT CALLS FOR THE ACCURACY AND RELIABILITY OF**



**T.M.C. HYDRA**  
BRITISH-MADE CONDENSERS

Made by **T.M.C.-HARWELL (SALES) LTD.**  
Telephone Mfg. Co. 233 Shaftesbury Avenue, W.C.2

**DEEPEES LIMITED** 35 BEAK STREET, REGENT STREET, LONDON, W.1  
PHONE: 2560 GERRARD.  
MANUFACTURERS OF AND DEALERS IN ALL SCIENTIFIC INSTRUMENTS

10-in. Ebonite Plate Wimshurst Machine, nickelled fittings. Every possible refinement.  
£3. 10. 0. Carriage extra.

SOME KNOW US. SOME DON'T. CALL AND MAKE OUR ACQUAINTANCE. YOU WILL BE SURPRISED AT OUR UNIQUE STOCK.  
AT HOME 9 to 7. 1 o'clock SATURDAYS.

**INCREASE YOUR HEIGHT FOR 1935**



Good Luck favours the Tall, everyone agrees. So why not be taller? This is the best time to add those vital inches that only the Challoner Treatment gives so quickly and readily. No arduous time-wasting exercises or appliances. One box will work wonders. But if one is insufficient we guarantee to supply another FREE. E. H. (Sutton) writes: "Results beyond expectations." Follow his lead. Send 1½d. stamp for full details in sealed envelope. Sample 7½d. Book on height improvement 3d. P.O. or stamps only. Overseas, Return Air Mail 6d. extra.

THE CHALLONER CO. (late Bond Street), Dept. E90, Laboratory and Works, Hyde Heath, Amersham, Bucks.

**Engineers' Guide**

containing the widest choice of engineering courses in the world

Study at home with The T.I.G.E. for a well-paid post. Become an A.M.I.C.E., A.M.I.Mech.E., A.M.I.E.E., etc. Training until Successful is guaranteed. WRITE NOW for Free Guide stating branch, post or qualification that interests you, to THE TECHNOLOGICAL INSTITUTE OF GREAT BRITAIN, 123 Temple Bar House, London, E.C.4. (Founded 1917, 19,000 Successes.)



**To Success**

(Continued from page 193.)

**An Electric Heater**

A HEATER that will no doubt be appreciated by most readers, especially motorists, and suitable for 200/250 volts 50 watts, can now be obtained at a very moderate price. Measuring 13 in. long, 2 in. in diameter, it is obtainable complete with 3 yd. of flex and an adaptor. It consumes only 50 watts, and gives twenty hours heat for about a penny. For the car owner it ensures quick starting during cold weather and prevents the engine freezing.

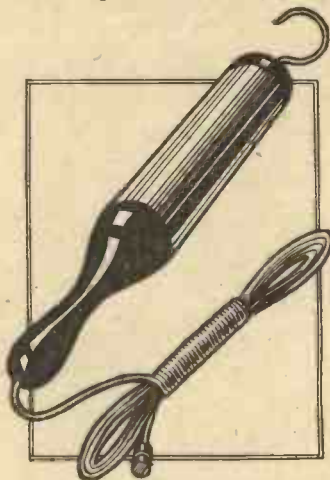

An electric heater which is moderately priced and has a number of uses.

The heater will also be found useful for keeping an even temperature in airing cupboards, etc. The price is only 9s. 6d., but with three-core flex costs 1s. 9d. extra. [102.]

**A Flashing Lampholder**

THE automatic flashing lampholder shown at the foot of this column will prove very useful for shop window display, electric signs, decorations, etc. You simply plug a "Blinker," as it is called, into a lampholder and insert the lamp in the usual way. The bulb will then attract attention by flashing automatically. No fitting or adjustment is necessary, as it is entirely automatic, and the period of flashing is tuned to prevent discomfort to the eyes. It is supplied for all standard voltages and from 40 to 100 watts. It costs 5s. [103.]

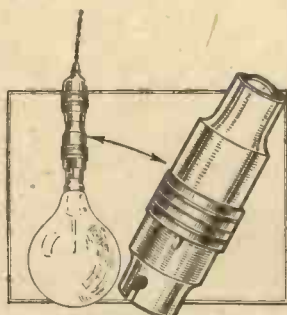

Details of the automatic flashing lampholder.

**"00" Gauge Railway**

THOSE readers interested in model railways cannot do better than pay a visit to Messrs. Hambling, of 26 Charing Cross Road, London, W.C.2, to inspect their new showrooms. This firm are the London agents for "Merco" productions, and all of this firm's interesting products are on view. Useful advice on track layouts, suitable accessories, etc., are gladly given to interested visitors.

**THE GLUE THAT GRIPS**

Use **Ste-Fix**

**A PURE VEGETABLE GLUE**

**ODOURLESS COLOURLESS**

For Joinery, Fretwork, Leather, Model-making, Repairing Pottery, Glass-ware etc. and for all purposes where a really powerful adhesive is required.

In Tubes 2d., 6d. and 9d.

Made by the Proprietors of **STEPHENS' INKS,** 57 Aldersgate Street, E.C.1.

**ALWAYS READY FOR USE**

**An Absorbing Hobby**

Building a Stuart model is an engrossing pastime, and the result a continuous pleasure



We illustrate:  
**STUART NO. 10.**  
High Speed Steam Engine.  
Bore ¾".  
Stroke ¾".

Each set is quite complete—drawings and instructions are included.

If you have a lathe—  
The rough castings - - - - 8/6  
If not—  
Fully machined set - - - - 18/6  
Ditto, with all holes drilled and tapped 25/-

This and many other Stuart engines are fully described in the 80-page Catalogue No. 3. 6d. post free.

**STUART TURNER LTD.**  
**HENLEY - ON - THAMES**

**GOVT. Surplus TELESCOPES**



High-grade Instruments to rigid Only Admiralty Specification. Cost £25 17/6 each. Telescopes were for long-range naval and army guns. Focus draw-outs avoided by internal adjustment operated by milled band g. on rapid thread screw. A fitting is provided for the use of a pea lamp for night sighting. Telescopes are slightly soiled but otherwise perfect, and each is in hard wood carrying case. They are **A WONDERFUL BARGAIN** at 17/6.

**Best Value Ever Offered in MICROPHONES.** 5,000 new Western Electric type Transmitters, speech and sound 1/- each etc., complete and perfect, 1/- post 2d. Microphone Transformers, 3s. 6d. each.

**HOME RADIO MIKES**  
5/6 and 15/- Illustrated List Free.

**EDISON STEEL CELLS.** We have some of these high capacity discharge cells cheap up to 400 a.h.

**COIL TURN COUNTERS,** for checking the number of turns up to 9,999 on dial. Soiled only, 1/3 each.

**METERS.** We carry large stocks of Meters, all ranges. Special Charging CZ 3-0.3 amps. 5/- Pole Testers, 2/6, 0-20 volts, 5/6, 0-50 volts, 5/6, 0-100 volts, 5/6, 0-200 volts, 6/6, all A.C. or D.C.

**MOTORS.** Special line of A.C. fractional H.P., 100 volt, 15/-; 220 volt, 17/6. Large stock of all sizes for Cine work. State volts and supply.

Write for Special Bargain List "P.M." Free.

**ELECTRADIX RADIOS**

218 Upper Thames Street, London, E.C.4  
Telephone: Central 4611.

**BINDING YOUR ISSUES OF "PRACTICAL MECHANICS"**

(Continued from page 178.)

to take up the swelling at the back. Firstly, rub a damp cloth over the back to make the hardened glue pliable.

Fig. 6 illustrates the method of rounding. The pages are pulled over with the left hand and gently tapped into position at the back with the right hand. One-half being done, turn the book over and round the other half. Repeat these operations several

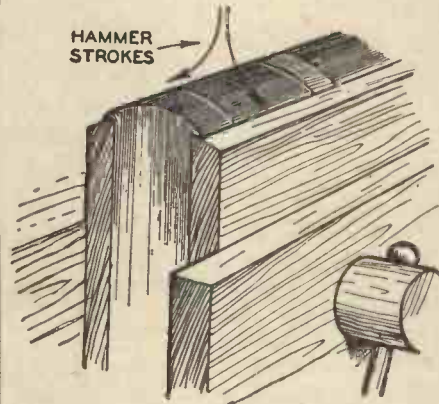

Fig. 8.—With a hammer lightly tap the sections over to each side until the back takes on the shape shown.

times until the back takes on an even convex form. Rounding should not be overdone or a badly shaped book will result; Fig. 7 shows the right form.

**The Head and Tail Edges**

Here again, if the sections are fairly level, they may be sandpapered between strawboards. "Backing" the book is the next step. Shape two pieces of wood as shown in Fig. 8, and place a board on each side of the book a short distance away from the back equal to the thickness of strawboard used for the cover. Taking care the boards do not slip, lower the whole into the vice and tighten securely.

With the hammer, lightly tap the sections over to each side until the back takes on the shape shown in Fig. 8. This forms a groove on each side to accommodate the cover boards, and from now the book must not be laid on its side without a board underneath to protect these grooves.

Cut a piece of bookbinder's mull, or coarse muslin, about 1 in. less than the length of the back and wide enough to overlap 1 1/2 in. on each side. Glue the back and place the mull in position, 1/2 in. away from the head and tail.

Now cut a piece of fairly stiff brown paper slightly less than the length of the back and twice the width. Glue up the back of the book again and fold the paper in half lengthwise. Lay one of the folded sides on to the glued back, rubbing down with the paper folder. Once again glue the back and rub down the other half of the paper. Leave undisturbed until dry.

**The WEBLEY SERVICE AIR RIFLE, Mk. II.**

No licence required to purchase

WRITE FOR DESCRIPTIVE FOLDER

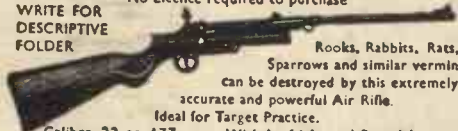

Rooks, Rabbits, Rats, Sparrows and similar vermin can be destroyed by this extremely accurate and powerful Air Rifle. Ideal for Target Practice.

Calibre 22 or 177 With Leaf-sight and Peepsight.

WEBLEY & SCOTT, Ltd. 306 Weaman St., BIRMINGHAM 4

**I WILL MAKE YOU A BRILLIANT PIANIST**

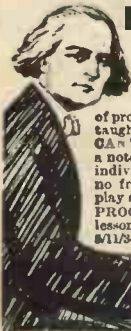

I do not say I may—I WILL if I accept you as my pupil. I am enrolling 80-100 adults every week and DURING THE PAST 30 YEARS HAVE TAUGHT 40,000 pupils of all ages, occupations and degrees of proficiency to play the piano brilliantly. I have taught over 2,000 these last 12 months and I CAN TEACH YOU, even if to-day you do not know a note. I give Lessons personally to suit your individual needs using ordinary musical notation, no freakish methods, enabling you to read and play at sight any standard musical composition. PROOF:—"I am extremely delighted with the lessons and am progressing wonderfully."—E. M., 8/11/34. Y40066. Age 24. Send p.c. for FREE Book "Mind, Muscle and Keyboard," and form for FREE advice. Say Advanced, Moderate, Elementary or Beginner. MR. H. BECKER, (Dept. 258) 63 Fleet Street, London, E.C.4

**THE AERIAL MACHINE-GUN RECORDING CAMERA**

(Continued from page 179.)

ruby window is provided in order that the operator may easily ascertain the number of pictures which have been taken.

The airman takes to the air and searches round for his opponent—another airman who is undergoing a similar stage of training. He manoeuvres round until he sees his adversary and then dives on him, or comes up under his tail, according to the method of attack which he has decided upon. Training his "gun" on the 'plane, he waits

which will take it approximately to the centre. By the size of the image it would probably be just past the centre when the "bullet" hits its target, and thus the hit would be just about the bottom of the observer's cockpit. For a direct hit on the engine, for instance, the machine should be direct on a diagonal with the foreshortened view shown in this picture. Obviously, if the machine appeared in the picture travelling exactly at right-angles to the attacking machine, it would be seen on the horizontal



Fig. 4.—The close resemblance of this camera to the standard service machine-gun is evident from this photograph.

until his pilot has brought the machine into a suitable position, and as the 'plane looms up into his sights he presses the trigger. Instantaneously a picture of the attacked 'plane is taken, through the target rings, and it only remains to develop the film and ascertain the accuracy of his aim. Obviously, it cannot be arranged that a delay action occurs on the gun so as to take a picture of the actual spot which would be hit, so calculations have to be made, and the right-angled lines are very useful here. For instance, in the actual example (Fig. 3) the attacked 'plane is travelling on a line

line, and its position on the "rings" would correspond with the size of the picture, thus again depending upon its distance from the attacker at the moment of firing. If the image is too small, it will indicate that the trigger was pressed too soon, and thus the bullet would have dropped (owing to its trajectory) before it reached the 'plane. It is obviously dangerous to get too close, but the larger the image the better the shot; and during the war some very interesting pictures were taken, in many of which the pilot or observer in the attacked 'plane could be identified.



**BE A MAN**

I positively GUARANTEE to give you Robust Health, Doubled Strength and 10-25" more muscle in 30 days or return your money in full. The famous STEBBING 4-in-1 Course consists of four great courses in one, yet costs only 5/- post free. It has been proved (1) The most effective HEALTH and ENERGY System ever devised; (2) It quickly builds NORMAL WEIGHT and VIRILE MANHOOD; (3) It develops a Strong Will, rigid SELF-CONTROL; and (4) It includes an amazing SUCCESS and PERSONAL MAGNETISM Course. Complete Course, 5/-

No extras, no appliances to purchase. Further details sent privately, under plain, sealed cover. LIONEL STEBBING, STEBBING INSTITUTE, Dept. C.P., 28 Dean Road, London, N.W.2.

# REPLIES TO QUERIES & ENQUIRIES

If a postal reply is desired, a stamped addressed envelope must be enclosed. Every query and drawing which is sent must bear the name and address of the sender and be accompanied by the coupon appearing on page 111 of cover. Send your queries to the Editor, PRACTICAL MECHANICS, Geo. Newnes Ltd., 8-11 Southampton Street, Strand, London, W.C.2.

## ADAPTING A CAR DYNAMO

"I have a 12-volt car dynamo which I should like to incorporate in a small charging unit to supply D.C. for my car accumulator or drive a model railway, etc.

"It appears to be a fairly heavy type C.A.V. from an old Daimler car.

"Would you be kind enough to advise me as to what type of electric motor would be most suitable to drive it? Our current is 200 v. A.C.

"Also could I couple up to the motor a centrifugal water pump (from car) to work a fountain or cascade from my rock garden to pond, say a lift of 3ft. to 4 ft. between water levels?" (E. C., Bournemouth.)

You will require a  $\frac{1}{2}$ -h.p. motor running at about 1,500 revolutions. Try and obtain direct drive if possible and have a shunt regulator in the dynamo field circuit for voltage control.

You can couple the pump to the motor, as this will only require a very small fraction of the total power. We cannot give any details of the Daimler pump, but doubt if it will lift more than 3 ft., as these are designed more as impellers to circulate the water rather than suction and delivery pumps; however, the experiment is well worth trying.

## DETECTION AND COAGULATION OF BLOOD

"(1) Could you give me details of all the known tests for detecting the presence of blood?"

"(2) A list of substances that coagulate blood and the approximate times they take?" (E. C. B., Harpenden, Herts.)

The detection of blood is carried out by means of one or more of the following tests:—

The suspected blood, no matter whether in a liquid, dried or pasty condition, or in the form of a stain on cloth or other material, is dissolved in a solution of one part of glycerine in seven parts of water. Rust stains will not dissolve in this solution; blood stains are soluble in it. The blood solution, prepared as above, is then subjected to the following tests:—

### (1) Microscopic Test

A drop or two of the solution is examined under a microscope. If blood corpuscles are seen, the presence of blood is conclusive.

### (2) "Hæmin Test"

If the blood or the blood stain is old, the corpuscles will have disappeared. However, they will leave their colouring matter behind them. This can be detected by adding a drop or two of dilute acetic acid to a small quantity of the blood solution and also a grain or two of common salt. The resulting liquid is then gently heated in a small test-tube. It is then allowed to cool. On cooling, dark brown minute crystals will often separate out. These are crystals of "hæmin," and they can be identified under the microscope. The above "hæmin test" can be confirmed by adding a drop or two of hydrogen peroxide to the test-tube containing the hæmin crystals. Small bubbles of gas will be evolved from each crystal.

It will be found that this test is perfectly conclusive for blood, no matter how old it may be.

### (3) Guaiacum Test (Day's Test)

Add a drop or two of tincture of guaiacum to the solution of the blood stain and then pour a few drops of ozonised ether on to the top of the liquid contained in a test-tube. A blue colour will be produced at the place where the two liquids meet if blood is present in the solution. This is an extremely delicate test for blood.

### (4) Spectroscopic Test

This gives the best proof of the presence of blood. A drop or two of the blood solution is examined in a special type of spectroscope. Certain dark spectral lines are produced if blood is present. This test is said to be sensitive to one-thousandth part of a grain of blood hæmoglobin. It should be noted that the above tests do not indicate whether the blood is of human or animal origin. There is no conclusive test for deciding this point. A good opinion can be formed, however, by an experienced analyst by examining the blood corpuscles under the microscope.

The following chemicals coagulate blood. It is impossible to indicate their coagulation times, because in every case the coagulation time differs from individual to individual and from animal to animal. It also varies in different states of health. Generally speaking, however, blood takes from one and a half to eight minutes to coagulate properly. The following coagulants are listed roughly in order of their efficiency: Mineral acids, ferric chloride, calcium chloride, alum, tannic acid (also all substances containing tannic acid and tannins), lead acetate, gallic acid, lime, salts of some of the heavier metals, such as copper sulphate, lead nitrate, silver nitrate, zinc sulphate, cadmium sulphate and bismuth nitrate.

## INSTALLING A D.C. PLANT

"I have been a reader of 'Practical Mechanics' for some time, and have taken great interest in 'Replies to Queries,' having always found some very enlightening information on that page.

"I am now myself faced with some problems, so perhaps you will be good enough to assist me. I have recently been transferred (through my occupation) from a town to a rural district, and the new house is without electricity. I am desirous of installing a private plant to supply D.C. current at 200 v.

"My questions are:—

"(1) What must be the output of my generator to operate four 60-watt lamps, two 100-watt lamps, and one 550-watt vacuum cleaner?"

"(2) Where can I obtain such generator at most reasonable cost?"

"(3) What type and capacity must my batteries be?"

"(4) What number do I require?"

"(5) Of what horse-power must my driving unit be to perform the work?"

"(6) What will be the approximate cost of installing plant? (Please give list with approximate prices opposite.)

"If you can answer me these questions, I shall be very grateful, as I have asked several electrical engineers, who appear to be very reluctant to part with information." (R. P., Nr. Sheffield.)

We cannot recommend the installation

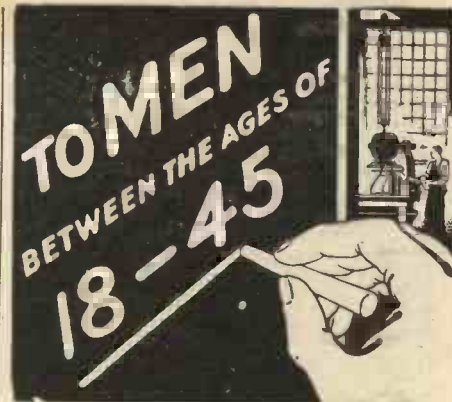

Things are happening to-day which vitally affect you!

If you are about 18, perhaps you are getting settled in your chosen work and already feeling the strain of competition for a better position. If you are in the 40's, your family responsibilities are near the peak, the necessity for money is tense—and younger men are challenging your job. And men of the ages between 18 and 45 face similar problems, in one form or another.

The most valuable employment security to-day is the security a man creates for himself—in himself! Through training, he is able to adapt himself to new conditions, to utilise experience without being handicapped by habit! He masters jobs and makes new jobs. He meets emergencies—and is not overwhelmed by them. And this is an age of emergencies.

For 43 years the International Correspondence Schools have helped thoughtful and ambitious men to acquire the training they need. To-day with this need more urgent than ever, this world-famous institution offers greater opportunities than ever. Why not permit us to show you the way to greater security and larger earnings? Our expert advice is free. Write to-day.

## ...COUPON FOR FREE BOOKLET...

INTERNATIONAL CORRESPONDENCE SCHOOLS, LTD.,  
Dept. 95, International Buildings, Kingsway,  
London, W.C.2

Please send me your booklet containing full particulars of the Course of Correspondence Training before which I have marked X. I assume no obligation.

- |   |  |
|---|--|
| <input type="checkbox"/> Accountancy              | <input type="checkbox"/> Marine Engineering            |
| <input type="checkbox"/> Advertising              | <input type="checkbox"/> Mechanical Engineering        |
| <input type="checkbox"/> Aeronautical Engineering | <input type="checkbox"/> Mining Engineering            |
| <input type="checkbox"/> Architecture             | <input type="checkbox"/> Motor Engineering             |
| <input type="checkbox"/> Bookkeeping              | <input type="checkbox"/> Plumbing                      |
| <input type="checkbox"/> Building                 | <input type="checkbox"/> Radio                         |
| <input type="checkbox"/> Chemical Engineering     | <input type="checkbox"/> Railway Equipment and Running |
| <input type="checkbox"/> Civil Engineering        | <input type="checkbox"/> Salesmanship                  |
| <input type="checkbox"/> Draughtsmanship          | <input type="checkbox"/> Steam Engineering             |
| <input type="checkbox"/> Electrical Engineering   | <input type="checkbox"/> Textiles                      |
| <input type="checkbox"/> Engineering Design       | <input type="checkbox"/> Woodworking                   |

Examinations, state which.....

The I.C.S. teach wherever the post reaches, and have a wide variety of courses of Study. If, therefore, your subject is not in the above list, write it here.

Name..... Age.....

Address.....

## LET ME BE YOUR TRAINER



I will train you to be the MAN you want to be. How would you like such a development as the man in the photo? Get Virile Health, Manly Strength, Stamina, Personal Magnetism and enjoy every moment of your life. I have had THIRTY YEARS' experience in training all ages. My system is different from others. Why not have a PERSONAL TRAINER all to yourself? Every pupil is trained according to his requirements and receives UNLIMITED TRAINING. I will send you a Free Lesson and a Handsome Photo Plate and full details on application. It is the personal touch which counts in Postal Tuition. It costs nothing to enquire. WRITE NOW.

Dept. "P.1."

PROFESSOR GARRUD'S INSTITUTE  
BEDFONT LANE, FELTHAM, MIDDLESEX

AIRCRAFT SUPER  
SEND 1/6 NOW

Not a new watch but an old and tried favourite in a modern style, as supplied to members of Air Force, Army and Navy. 1/6 deposit secures this watch—non-magnetic, shock and vibration-proof. Recoil Click spring prevents over-winding. Unbreakable glass. Silver or plain luminous dial as desired. Untarnishable Chrome case and Chrome milanese adjustable bracelet. Not until this watch keeps time to a minute a month is it allowed to leave our model factory. Guaranteed 10 years in writing. Send only 1/6. Test for 7 days. If satisfied send 2/6 fortnightly until 3/7/6 is paid in all. Cash price 3/6. Ladies' solid silver model same price and terms.

AIRCRAFT PRODUCTS LTD. (P.M. 101),  
89 New Oxford Street, London, W.O.1.  
(Opposite Glaves' Central Entrance.)

Add 50/- WEEKLY  
to your earnings

by charging accumulators  
in your spare time.

Complete plant for A.C. mains incorporating Westinghouse Rectifiers to charge 105 L.T. cells weekly. Price 23/6, or 8s. monthly. Send for descriptive Booklet No. P.M.14.

M.P.R. Ltd  
ESSEX.



## WHY BE THIN?

BUILD UP YOUR BODY AGAINST ILLNESS  
AND DISEASE. DON'T HIDE YOUR BONES  
UNDER AN OVERCOAT!

Thousands have put on weight and muscular tissue with  
the aid of

VITAEAPON (THE ENEMY OF  
THINNESS)

A customer writes:—"After my illness I gained 15 lb. in weight, and my nerves improved tremendously as the result of a six weeks' course of Vitaeapon."

Vitaeapon is not a drug—simply take two tablets  
with the morning and evening meal.

Obtainable only from:—

WESTCOTT & CO. (Dept. P.),  
37 Albemarle Street, Piccadilly, London, W.1.

For Week's Trial Supply send P.O. for 3/- or 15/- for full six weeks' course. Abroad by registered post, 3/6 and 16/-, post free. Sent in plain covers.

A new book, entitled "Thinness: Its Cause and Cure" sent free with every six weeks' course.

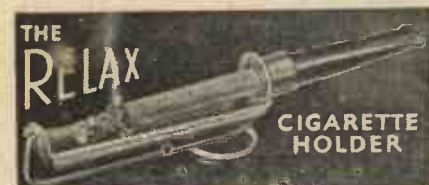

CIGARETTE  
HOLDER

THIS COMBINED ASH-TRAY AND CIGARETTE HOLDER will be found ideal for smokers while reading or relaxing. The tray will catch ash irrespective of the position of the holder, its upright position being maintained by gravity, and it will be found almost impossible to upset. The "RELAX" is both light and strong, and is provided with a small stand as shown. The tray is polished aluminium and the support and stand stainless steel. The mouthpiece is made in Black, Blue, Red and Amber.

Sole Manufacturers: BRYANT BROS.,  
Perseverance Works,  
2a Brighton Road, LONDON, E.6 Post Free

PRICE  
1/9

of a 200-v. plant for such a small load. The cost is prohibitive and the maintenance work on the cells, etc., would occupy a man for the greater part of his time each day. Fifty volts would be ample for your needs, and the cost will be greatly reduced. Answering your questions in the order as asked:—

- (1) About 200 v. 6 amperes.
- (2) Messrs. Electradix Radios, of Upper Thames Street, London, will supply new and second-hand machines.
- (3) Lead-acid open-topped glass-boxed cells of 80 ampere-hours.
- (4) A minimum of 100.
- (5) Three h.p. to cope with all loads.
- (6) Very approximate prices:—  
Batteries £50  
Wiring for seven points £8  
Engine and generator, second hand £20

The above figures must only be taken as a very rough guide, as you have not given us sufficient details for a very exact reply.

## HOUSE WIRING

"With reference to your interesting and helpful article on 'House Wiring for Electric Lighting' in your October, 1934, issue, I would like information about the following:—

"(a) In the case of braided cable, to keep within the regulations must it be enclosed in metal tubing where it is let into the channels made in the plaster of the walls?

"(b) Would an amateur experience any trouble in obtaining the materials required?

"(c) Is the lead from the right-hand terminal of the iron clad (when fixed in position) always recognised as the lead from the earthed main?

"(d) What is the ratio of the costs of using either of the three types of cables, and which cable do you suggest?" (J. E., Lancs.)

(a) It is essential that the wire is run through conduit in the plaster.

(b) The materials can be obtained from any supply house.

(c) It is immaterial which side of the switch is earthed, but the earth lead must of course, be connected to the correct side,

(d) If you are adopting the method of wiring as in the article, tough rubber-sheathed cable must be used, and thus we recommend a 600-megohm grade. Prices for this wire per 50 yd. are: 1/044 cable, 8s. 4d.; 3/029, 10s. 3d. The above is for single cable, and there is a slight reduction on a 100 yd.

## THE "MERCURY HEART"

"Could you explain for me the following phenomenon? : When a needle is stuck into a small globule of mercury in a dish containing moderately concentrated sulphuric acid, the mercury at once begins to 'beat,' imitating the action of the human heart.

"The following clues may help: (a) There must be carbon in the needle; (b) only certain concentrations of acid will do; (c) the surface tension of the mercury must be a maximum (i.e., it must be clean). I have been unable to obtain a satisfactory explanation of this, so I hope you can oblige me." (E. J. S., Northumberland.)

The phenomenon of the "mercury heart" is not a well-known one, and it is one concerning which there exists no authoritative explanation.

It is usually assumed that the effect is due to the existence of a local electric cell—a difference of potential—between the steel and the mercury, the acid acting as the electrolyte. This explanation, however, is open to certain difficulties, mainly the one which you point out, i.e., that only steel containing carbon will show the effect. (Some workers, however, have reported that certain alloys of iron-nickel and iron-chromium give the "mercury heart" effect, although there is no confirmatory evidence in this respect.)

Another explanation of the phenomenon is that an amalgam is formed between the mercury and the steel, and that the dissolving effect of the acid on this sets up a pulsation in the mercury.

Still another explanation is that the dissolving effect of the acid on the steel needle and on the mercury globule takes place at different rates, thereby creating a vibratory period in the system.

What the Clubs  
are Doing

Club Reports for inclusion in this feature should not exceed 250 words in length, and should be received not later than the 12th of each month for inclusion in the subsequent month's issue.

STREATHAM COMMON MODEL  
RAILWAY CLUB

OUR clubroom at 201 Gleneldon Mews, High Road, Streatham, is open now every night each week for members' use.

We are having a small stand at the Schoolboys' Own Exhibition, and we shall welcome any readers to it. We had a most interesting and entertaining lecture by Mr. Fletcher of the West Essex M.R.C. in November, on "Scenic Effects." Mr. Fletcher has a complete "00" gauge line and passed on a number of interesting tips to members. Our latest issue of *The Rocket* is now ready, and can be obtained from the Secretary, price 5d. Full particulars from L. J. Ling, Brooke House, Rotherhill Avenue, Streatham, S.W. 16.

## INSTITUTE OF SCIENTIFIC RESEARCH

ON Saturday, December 1st, as a change from a lecture, a discussion entitled

"Can it be done?" was held. Interesting facts about perpetual motion, interplanetary transport, underground cities, flying bicycles, tides as sources of power, etc., were brought to light by members, and the discussion proved very enjoyable.

On Wednesday, January 2nd, a visit will be paid by the club to the match works of Bryant & May Ltd., and on Saturday, January 5th, a lecture entitled "The Atom and its Constituents" will be given by the Secretary.

May we once again remind readers of NEWNES PRACTICAL MECHANICS that a Correspondence Section has been formed in conjunction with the club, and that all persons interested should communicate with the secretary, Mr. D. W. F. Mayer, 20 Hollin Park Road, Roundhay, Leeds 8.

## PARK MODEL AIRCRAFT LEAGUE

ON Wednesday, January 30th next, a Dance, Social Evening and Exhibition of Models will be held from 7 p.m. till 12 at the FARNAN HALL, Farnan Road, STREATHAM. Tickets (1s. 6d. each) from the Dance Organizer, Mr. F. J. Saul, 305 Commonsides East, Mitcham, Surrey.

The Fourth Annual General Meeting and election of officers will be held at the Streatham Hall on Friday, February 1st. Meeting commences at 7 o'clock sharp. F. H. Dillistone, Hon. Sec., 112 Rodenhurst Road, Clapham Park, S.W.4.



# Money Making IDEAS

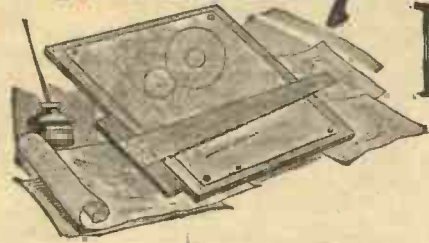

## PROPELLING A VESSEL BY SEA WATER

"I wish to submit the following idea for your approval. I also wish you to advise me as to whether I should patent it, and how to do so, if necessary.

"The idea is the propulsion of a vessel by sea water. Water is drawn in through the bows by a powerful force pump. As the piston of the pump moves back, the water is forced into a pipe, which is tapered off like a fish-tail exhaust, which increases the pressure, and is led out at the stern of the ship. By Newton's third law, to every action there is an equal and opposite reaction; the ship must be propelled forward by the force of water at the stern. For a reverse motion two such pumps will be required.

"This idea is advantageous inasmuch that it is more economical and also makes the vessel more sensitive to her helm." (M. O., Pembs.)

The proposed method of propelling ships by taking in water at the bows and ejecting it under pressure at the stern, commonly known as jet propulsion, is probably as old as the screw propeller. Many Patents have been granted for constructions embodying the jet principle, but so far as is known none has been a success.

It has now the established opinion that a jet propeller is much inferior to the screw as a means for propelling ships, and for this reason the inventor is advised not to expend further thought on his invention.

## A FOLDING BED-SETTEE

"Can you advise me regarding a patent I have for a folding bed-settee? This settee has been in manufacture for the last two and a half years by a furniture firm, under licence from me with a three-year agreement. The patent, as it stands, has for a claim, 'A folding bed-settee of the type hereinbefore described, whereby a single action only is required to convert from settee to bed form, and from bed to settee form.'" (J. W., Glasgow.)

It is difficult to give a definite opinion as to whether the new construction of convertible bed-settee is covered by the Inventor's original Patent, without a copy of the original Patent Specification, and fuller particulars of the improvement.

From the meagre particulars furnished, it would appear that the original Patent should cover the improved construction, but this naturally depends on how the Specification of the original Patent was drafted.

If the original Patent does not cover the improved construction, it could possibly form the subject-matter for a Patent of Addition to the original Patent. A Patent of Addition is only granted for an improvement in or modification of the original invention. No fees are payable on Patents of Addition, but they remain in force for the same term as the original Patent.

## SUGGESTED BY OUR READERS

It would not be possible to amend the original Patent to include the new improvement.

It may be good policy to apply for a new independent Patent for the improvement, but, as before stated, no definite opinion can be given without fuller particulars. The Inventor is advised to place the whole matter before a reliable and competent Patent Agent.

## A PROBLEM OF PARTNERSHIPS

"I am experiencing trouble with my partner in applying for the full patents on certain Prov. Patents, and would like your advice.

"Two years ago I conceived the ideas and asked Mr. B. (who is my partner now) to help me in my experiments and to see whether the ideas were patentable; he went into the matter and told me that it was covered, we dropped it; twelve months after, I found out that the matter patented had no bearing on my ideas. Having experimented with Mr. B. and taken him into my confidence I thought I was bound to him, so I approached him again and took patents out in our joint names, I paying the expenses. He has been trying to float a company, using the patent numbers as security, but his methods were rather on the border line, so I dropped out of the scheme, thereby stopping it.

"Now I want to take out full patents he won't advance any money to pay his share, and won't be satisfied with anything less than 50 per cent. if I pay everything, so we are at a deadlock. Can I apply for the Full Patents in my own name? I shall lose the priority time, I know; that can't be helped, the question is, can he stop me from getting the patent? The patents are dated January 31st, 1934." (H. R., Lancashire.)

There is provision under the Patents Acts for either one of joint Applicants for a Patent, where a Provisional Specification has been filed, to file a Complete Specification on the Application. Where disputes arise between joint Applicants as to proceeding with an Application, the Comptroller, if satisfied that one or more of such persons ought to be allowed to proceed alone, may allow him, or them, to proceed with the Application and may grant a Patent to him, or them, so, however, that all parties interested shall be entitled to be heard before the Comptroller. An appeal from the decision of the Comptroller may be made to the Appeal Tribunal, i.e., a judge of the High Court.

If your partner has refused to join you in completing the Application and agrees to have his name removed from the Application, provided he has not been described as joint inventor with you on the Application Form, you can apply to amend the Application by striking out his name without proceeding under the above section of the Act, in which case you can complete the Application without losing the priority date thereof and could obtain a Patent in your name alone, without fear of your partner successfully opposing the grant of the Patent.

# YOU CAN CONQUER

## The common COLD BY MAXALDING

Cold is only congestion and the resultant invasion of bacteria, through bad circulation and poor condition. For years past I have invited a Medical test of my method, promising that every organically sound person can prevent cold-catching or cure an existing cold.



**COURTLANDT SALDO,**  
SON OF A. M. SALDO,

stated by an eminent surgeon to be physically perfect, demonstrating the Maxalding control and development of the *SERRATUS MAGNUS* muscles. The stronger these muscles become, the greater will be the rib-separation at the moment when the nerve impulse is active.

Photograph guaranteed unretouched.

## Investigate Maxalding

by Letter or Coupon. If the Coupon is used *Please delete the unnecessary items* and post it together with the following particulars to Mr. Saldo: Name, Address, Age and Occupation. No obligation involved.

### COUPON

1. I suffer from and desire to be cured of Constipation, Indigestion, Bilioussness, Nervous Debility, Lung Weakness, Liver Sluggishness, Fatigue, Stomach Weakness, Lumbago, Obesity, Susceptibility to Colds, Lack of Self-Confidence, Dizziness when Stooping, Lack of Physical Development.
2. I desire to secure great nervous energy.
3. I desire to secure great speed and endurance.
4. I desire to secure great strength and heavy muscular development.

NAME.....

ADDRESS.....

Occupation..... Age.....

Postage or reply coupon for 3 ounces appreciated.

**MAXALDING (Dept. 869),**  
**14 Cursitor St., London, E.C.4**

# INEXPENSIVE CHEMISTRY EQUIPMENT

FOR STUDENTS' LABORATORIES  
 Complete range of **OHMIC** Apparatus in Bottles from 3d. each.—  
 Extensive selection of **APPARATUS**, including Beakers, Flasks, Graduated Ware, Condensers, Retorts, Balances, etc.  
**SPECIAL PARCEL OF APPARATUS.**  
 1 Flask, flat bottom 100 c.c., 1 Beaker, spouted 100 c.c., 5 Test Tubes 4 in. x 1 in., 1 Thistle-Funnel 20 c.m., 3 ft. Glass Tubing, 1 Rubber Cork 2 holes 4 inches Rub. Post  
 ber Connection Tubing, 1 Glass Stirring Rod. **2/6** Free  
**BECK (Scientific)** 60 HIGH STREET, (Dept. A.) STOKES NEWINGTON, N.16  
 Write for Catalogue—FREE.

<b>PATENTS, TRADE MARKS AND DESIGNS</b>	<b>ADVICE, HANDBOOK AND CONSULTATIONS FREE!</b>
<b>KINGS PATENT AGENCY LTD.</b>	
Director: B. T. King, O.B.E., Reg. Pat. Agent G.B., U.S.A. & Can.	
146a Queen Victoria St., LONDON, E.C.4	
and 87 Chancery Lane (near Patent Office), W.C.2.	
49 Years References. <b>TELEGRAMS:</b> GEOLGIC, LONDON.	
<b>PHONE:</b> CURY 6161.	

## PRACTICAL HINTS ON PATENTING and the development of inventions.

Sent free on application.

**THE IMPERIAL PATENT SERVICE**  
 First Avenue House, High Holborn, W.C.1.  
 Principal: M. E. J. GHEURY DE BRAY, F.P.S.  
 Preliminary Consultation Free. Telephone: Holborn 9191.  
 Telegrams: Imperatrix, London.

### PATENTS, DESIGNS AND TRADE MARKS

A VALUABLE GUIDE ON INTERNATIONAL PROTECTION OF INVENTIONS.  
 100 Pages - - Post Free, 6d.  
**The TECHNICAL ADVERTISING AGENCY**  
 253 (D) Gray's Inn Road, London, W.C.1

### FROST & CO.

70 Old Compton St., London, W.1  
 Engineers, Tool and Model Makers.  
 Models of all descriptions.  
 Inventors, Scales and Advertising.  
 Patterns, Castings, or Finished Parts, Small Stampings and Press Tools.  
 Experimental and Repetition Work

## DON'T BE BULLIED



Learn to fear no man. The **BEST** self-defence ever invented, namely, **JULIUS**. Easy to learn. Send 2 penny stamps for **SPLENDID ILLUSTRATED LESSONS**, Photo **ARTICLE** Testimonials and particulars, or P.O. 1/- for **FIRST PART** of my course. You will be more than delighted.  
 Dept. P., Behnelm House, Bedford Lane, Fenchurch, Middlesex.

## HAVE YOU A RED NOSE?

Send a stamp to pay postage, and you will learn how to rid yourself of such a terrible affliction free of charge.  
 Address in confidence—  
**P. TEMPLE, Specialist,**  
 "Palace House," 128 Shaftesbury Avenue, W.1  
 (Est. 30 years.)



**"IDEAL-LATHES"** 3in. S.C. LATHES from 14.  
 3 1/2 in. S.C.B.G. from £7/18/6. LISTS, Stamp please.  
**J. WILLIMOTT & SON**, Neville's Factory, Chilwell, Notts.

### SOUND AND PICTURES

"I have thought of an idea for combining pictures with gramophone records, and I should be glad of your opinion as to its novelty. I have not been able to make a model of it, but theoretically it may work. Will it be necessary to make a model to patent it, if I draw it out fully?"  
 "I have drawn it so it works with ordinary records, to give simpleness in working, but it may work with a sound track as on talking films, and also the pictures put on a Blattnerphone strip."  
 "The principle on which it works is the Stroposcope, the intermittent light masking the movement of the picture, but if this does not act it should work just the same with ordinary film mechanism." (R. W. R., Birmingham.)

The proposed construction of apparatus for reproducing sound from gramophone records in combination with the projection of pictures from films is thought to be novel and forms fit subject-matter for protection by Letters Patent. The inventor is probably aware that the broad idea of projecting pictures from films in combination with the reproduction of sound from gramophone records is not broadly novel, the first "talking" pictures employed gramophone records for reproducing the sound. The proposed construction, essentially for home use, is novel so far as is known from personal knowledge, and if properly marketed, should prove a commercial success. It is not necessary to make a model of the invention before applying for protection by Patent, but it would be advisable to make a model during Provisional protection before completing the Patent Application, and a model would probably be necessary if it be desired to obtain financial assistance in putting the invention on the market.

The inventor is advised to file an Application for Patent for his invention with a Provisional Specification, which will give him protection for about twelve months. This procedure is the least expensive way of obtaining protection and gives the inventor time to work out the details of his invention and obtain financial assistance before incurring any great expense, the only drawback is that the official search for novelty is only made after the filing of a Complete Specification. Should you desire to proceed further in protecting your invention, the Editor will doubtless be able to put you in touch with a reliable Patent Agent, as professional assistance is desirable.

### A NOVEL INK BOTTLE

"A little idea has occurred to me and would like your opinion concerning same."  
 "Perhaps you have observed that it is difficult to get the last 'three-quarter inch' depth of ink out of the ordinary bottle with a self-filling pen. This idea is intended to remedy that state of affairs, as far as possible."  
 "Do you think a bottle of this type would have any commercial value? If it is novel, would it be worth taking out a patent?" (R. S., Shetland.)

The proposed ink bottle, if novel, could form fit subject-matter for protection by Letters Patent. A certain measure of protection could also be obtained by registration as a Design. The idea is novel so far as is known from personal knowledge, but it would be advisable to make a search amongst prior Patent Specifications. The ink bottle would possibly appeal to certain manufacturers specialising in ink for the users of fountain pens, but it is not thought to have any great commercial value.

# The DOSSELL Studio

**GOOD IDEAS—**  
 are often rejected because of unconvincing drawings! Let us prepare attractive illustrations which will convey your idea quickly and clearly to Manufacturers, Editors, Agents, etc.  
 We specialise in Patent Office and Technical drawings of all descriptions.  
 Write or phone us at  
**HIGH HOLBORN HOUSE, HIGH HOLBORN, W.C.1.**  
 Hol. 8638



## BE TALL

Your Height increased in 14 days or money back. The amazing Stebbing System soon brings 3-5 inches increase and new energy. The first, original, and the one **GENUINE GUARANTEED** Height Increase System. Recommended by Health and Efficiency. Complete Course, 5/-, or Booklet free, privately.  
**STEBBING SYSTEM**, Dept. M.P., 28 Dean Rd., London N.W.1

## BAND GUIDE

Makers: **POTTER'S**  
 38/38, West Street, Charing Cross Road, LONDON, W.C.2  
 Giving hints on the Bugle, Drum and Flute, also Parade Formations, use of Parade Cane, Staff, etc., free and post paid.

## BLUSHING FREE

to all sufferers, particulars of a proved home treatment that quickly removes all embarrassment, and permanently cures blushing and flushing of the face and neck. Enclose stamp to pay postage to Mr. M. Temple (Specialist), "Palace House," 128 Shaftesbury Avenue (2nd Floor), London, W.1. (Est. 30 years.)

## ROSS for HEIGHT!



**RESULTS SPEAK FOR THEMSELVES!** No Applications—No Drugs. No Dieting.  
 Pupil, age 19, gains 5 ins. in 6 wks.  
 " " 21, " 5 ins. in 5 mths.  
 " " 30, " 3 1/2 ins. in 16 dys.  
 " " 30, " 2 ins. in 4 wks.  
 " " 40, " 1 1/2 ins. in 6 wks.  
**ROSS SYSTEM** Increased my own height to 6' 3 1/2". NEVER FAILS  
 Hundreds of Testimonials from all over the world  
 Fee: £2 2s. complete. Details free. Write NOW  
**L. MALCOLM ROSS**, Height Specialist.  
 Scarborough, England. (P.O. Box 15.)

## MAKE YOUR OWN LEAD SOLDIERS

Cowboys, Indians, Animals, etc. Our **CASTING MOULDS** produce thousands without previous experience, from any scrap lead, etc. Illustrated Catalogue **FREE**. Sample Mould 2/9 post free.  
**J. TOYMOULDS**, 18 Kenyon Street, Birmingham 3.  
 Mention "Practical Mechanics."



## Baker's SOLDERING FLUXES

Sold in 6d. and 1/- tins at all Cycle Accessory Dealers, Tool Shops, Ironmongers, etc.  
 Write for your free copy "Joining of Metals" to  
**SIR W. BURNETT & CO. LTD.** (CHEMICALS)  
 GREAT WEST ROAD, Uxbridge, MIDDLESEX