

PRACTICAL

May 1991 • £1.50

ELECTRONICS

SCIENCE AND TECHNOLOGY

FREE
in this
issue

**32-Page
Greenweld
Catalogue**

Digital Compact Cassette

Philips is set to
revolutionise HiFi

Stabilised Power Supplies

Vital equipment
at a low price

Data Sheet

The 6522 VIA

How It Works

Get inside a VCR

£2000 to be Won!

Turn to page 30 for details

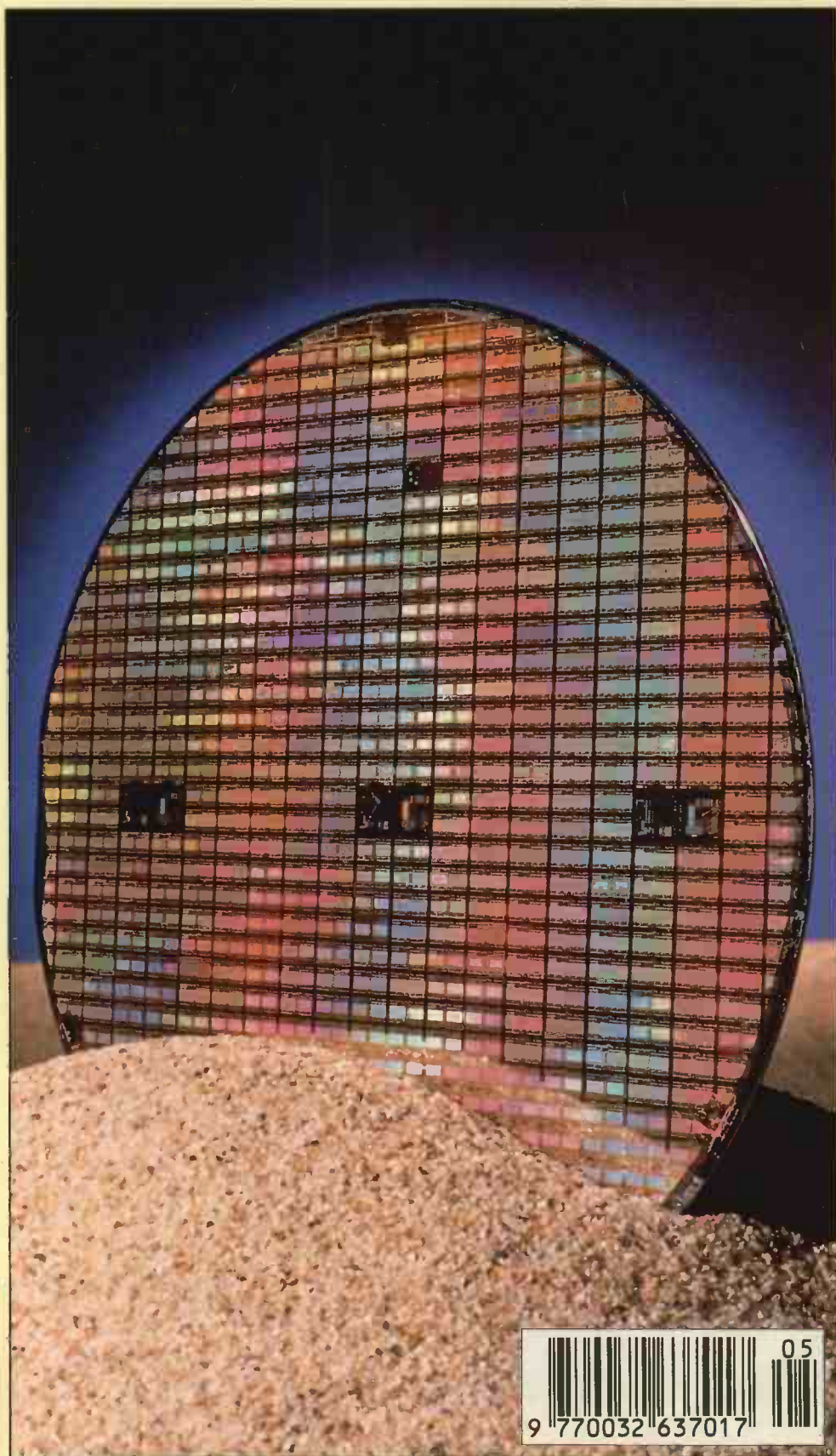

MICRONTA®

TALKING METER

ZERO POINT
ZERO ONE
VOLTS AC



NEW

22-164

£79.95

Tandy®

Talking Multimeter. Press a button on the probe and the meter calls out its reading in clear English. The reading is also shown on the unit's large easy to read LCD display. Features autoranging, autopolarity, continuity sounder, diode-check and over-range indicators. 10 megohms input. Measures to 1000 VDC, 750 VAC, 300 mA AC/DC, 30 megohms. Measures: 6¹³/₁₆ x 3⁵/₃₂ x 1¹/₄".

InterTAN U.K. Ltd., Tandy Centre, Leamore Lane, Walsall,
West Midlands. WS2 7PS Tel: 0922 710000

This month...

Digital Compact Cassette promises to cause a revolution in personal sound to equal or surpass the original Compact Cassette. CDs are wiping out vinyl LPs, but cassette sales have been even larger. Ian Burley reports on the new Philips system.

Our main project, John Becker's Telesnap, introduces video capture technology on your personal computer, while Chronos is a high-spec universal timer.

One of the most obvious examples of high technology in the home is the Video Cassette Recorder, which we take apart in How It Works. Another example of ubiquitous technology is the transistor which was instrumental in bringing about modern electronics. Another revolution may be on the way if room temperature superconductors become available. We take a look at the development of both of these technologies as well our usual coverage of the latest in electronics.

Kenn Garroch, Editor

Build It

TeleSnap	15
<i>Grab pictures off your TV and save them with a PC</i>	
Very Low Cost Power Supply	27
<i>Owen Bishop shows how easy it is to build a safe simple PSU</i>	
PE Chronos.....	37
<i>Build a Universal Counter Timer with this project</i>	

Features

Digital Compact Cassette.....	10
<i>Philips' breakthrough in personal HiFi revealed by Ian Burley</i>	
Transistors.....	22
<i>The origins of one of the most fundamental inventions ever</i>	
How It Works.....	46
<i>We take the lid off a VCR</i>	
Microcontrollers	44
<i>Replace dedicated circuitry with a single chip – but which one?</i>	
Superconductors	50
<i>The room temperature superconductor stands to revolutionise the world. John Brook examines the background</i>	

Next month...

Regulars

Wavelength.....	5
<i>We listen to what you say</i>	
Innovations.....	6
<i>A look at the latest chips and gadgets, and a roundup of international electronics news</i>	
Data Sheet	31
<i>The widely used 6522 VIA gets the data sheet treatment</i>	
Practical Components.....	34
<i>Two bits of metal and an insulator – there is a lot more to capacitors than meets the eye</i>	
Techniques	58
<i>Andrew Armstrong with power controllers and Standing Wave Ratios</i>	
Book Reviews	61
<i>The latest in libraryware</i>	
Barry Fox	63
<i>The President of Philips looks to the future and reveals the identity of a secret partner</i>	



As personal computers become cheaper and more powerful the specialist software required to produce professional quality PCBs follows suit. We test Seetrax's CAD package.

Editor: Kenn Garroch Technical Editor: Andrew Armstrong Technical Illustrator: Derek Gooding Advertisement Manager David Bonner Production Editor: Richard Milner Production Assistant: Michael Sullivan Office Manager: Laura Esterman Office Secretary: Wendy Rhodes Publisher: Angelo Zgorelec • Practical Electronics Intra House 193 Uxbridge Road London W12 9RA Tel: 081-743 8888 Fax: 081-743 3062 Telecom Gold: 87: SQQ567 • Advertisements The Publishers of PE take reasonable precautions to ensure that advertisements published in the magazine are genuine, but cannot take any responsibility in respect of statements or claims made by advertisers. The Publishers also cannot accept any liability in respect of goods not being delivered or not working properly. © Intra Press 1991. Copyright in all drawings, photographs and articles published in PRACTICAL ELECTRONICS is fully protected, and reproduction or imitations in whole or in part are expressly forbidden. All reasonable precautions are taken by PRACTICAL ELECTRONICS to ensure that the advice and data given to readers is reliable. We cannot, however, guarantee it, and we cannot accept legal responsibility for it. Prices quoted are those current as we go to press. All material is accepted for publication on the express understanding that the contributor has the authority to permit us to do so. • Practical Electronics is typeset at Intra Press on Macintosh computers using Quark Xpress. Reproduction by Tetracolor Ltd. Printing by Andover Press, St Ives plc. Distribution by Seymour Press • ISSN 0032-6372 •

Psst... Powerful Software Saves Time

ISIS - Intelligent Schematics

ISIS SUPERSKETCH - our highly popular schematic drafting package. Still only **£69** (basic library).

ISIS DESIGNER - no nonsense schematic capture with Netlist, Bill of materials and ERC reports. Excellent value at **£275**.

ISIS DESIGNER+ - Design Management Tool with Hierarchical Design, Auto Annotation and ASCII data import. Unrivalled features for just **£475**.

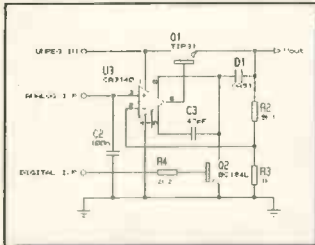

- Auto wire router.
- Auto dot placement.
- Auto label generator.
- Auto component finder.
- Object oriented 2D drawing.
- Comprehensive libraries.
- Integral Device Editor.
- Output to dot matrix, pen plotters, lasers, POSTSCRIPT.
- Export to DTP in IMG or DXF.
- Runs on any PC compatible with mouse.

ARES - Advanced Routing

PCB II - an exceptionally easy to learn PCB drafting package - ideal for the computer-phobic and only **£69**.

ARES - advanced PCB design with netlist integration, 10 routing layers, EMS memory support, DRC, auto ground planes and more. Attractively priced at **£275**.

ARES AUTOROUTE - our new autorouter uses an advanced multi-strategy algorithm to achieve very high completion rates. **£475** price tag includes ARES.

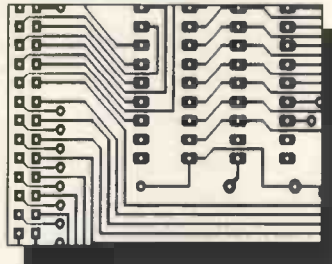

- Topological Route Editor
- Unlimited user configurable pad, track and via styles.
- Surface mount & metric support.
- 1 thou resolution.
- 30x30 inch max board size.
- Object oriented 2D drawing for silk screen graphics.
- Drivers for dot matrix, pen plotters, lasers, POSTSCRIPT, gerber, NC drill.

Labcenter
Electronics

COMBINATION PRICES

SUPERSKETCH & EXT LIB & PCB II .. £149
 DESIGNER & ARES £500
 DESIGNER & ARES AUTOROUTE..... £675
 DESIGNER+ & ARES..... £675
 DESIGNER+ & ARES AUTOROUTE.. £850
 Prices inc UK delivery, exc VAT.



Call for demo disks today - 0274 542868.



14 Marriner's Drive, Bradford. BD9 4JT

UPGRADE OR BUILD YOUR OWN IBM COMPATIBLE



MOTHERBOARDS

CPU	RAM	L/SPEED	PRICE
286-12	0k	16Mhz	£105
286-12	1Mb	16Mhz	£165
386 SX	0k	19Mhz	£285
386-25	0k	33Mhz	£485
386-33	64k cache	54Mhz	£850

GRAPHIC CARDS

VGA	256k	16 BIT	£75
SUPER VGA	512K	16BIT	£95

ADD-IN CARDS

Floppy Hard Disc Controller	£59
I/O Card for XT/AT	£28

BOOKS

Build your own 80286 IBM Comp-Pilgrim	£16.30
PC Upgrade Book South	£11.85

KEYBOARDS

IBM + COMPATIBLE	£35
AMSTRAD 1640/1512	£59
PS2 + COMPAQ	£75

FLOPPY DRIVES

360k	5.25	£55
1.2M	5.25	£59
720k	3.5	£55
1.44	3.5	£59

HARD DISC DRIVES

ST 225 20Mb 68MS 5.25"	Half Height	£145
ST 251 40Mb 28MS 5.25"	Half Height	£240
IDE hard disc 40Mb 28MS 3.5"	Half Height	£219
Dual Drive Cable Set		£10

Write, Phone or Fax for a FREE Catalogue
 All prices exclude 15% VAT (Carriage by Post)

MANY OTHER PERIPHERALS AVAILABLE

PANRIX
ELECTRONICS

93 KENTMERE APPROACH,
 LEEDS LS14 1JW.
 Tel: 0532 650214
 Fax: 0532 300 488



Global

Fast Efficient Design & Test

INTEGRAL LOGIC PROBE, PULSERS, INDICATORS & SWITCHES

CMOS & TTL COMPATIBLE

LARGE SOLDERLESS BREADBOARDS 2520 CONTACT POINTS (Lifetime Guarantee)

INTEGRAL POWER SUPPLIES

COST EFFECTIVE FOR EDUCATION

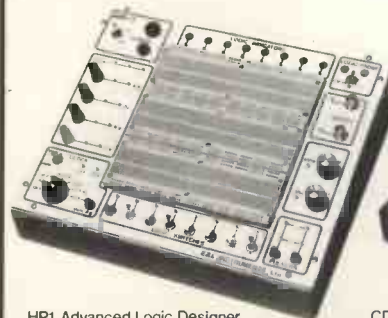

HP1 Advanced Logic Designer



CDA1 Proto-Board

E & L Instrument Global Specialist



TEACHING & TESTING

Rackery Lane, Llay, Wrexham, Clwyd, LL12 0PB, United Kingdom
 Telephone: (0978) 853920
 Telex: 61556
 Fax: (0978) 854564

Wavelengths

If you have any comments, suggestions, subjects you think should be aired, write to PE

Double Winner

I can't believe my luck. When I was lucky enough to win £118.16 in the reader loyalty bonus, published in the March issue, I didn't think anything would come of any entry to the next bonus. However, upon reading the April issue of PE, I discovered that my name was on the winners list again! I look forward to receiving my second cheque and will certainly continue to read PE.

Mr. D Brook
Mill Hill
London

Video What Adaptor?

It is unusual for me to put pen to paper (or indeed, fingers to keyboard) on such a matter. However, I feel that I am bound to correct the mistakes I encountered in the 1991 March edition of PE. Normally I choose to ignore mistakes when they appear, but one discrepancy in particular seems to be made by many electronics related publications.

Surely VGA (in your article on CAD) refers to Video Graphics Array not Versatile Graphics Adaptor, and MCGA to Multi-Colour Graphics Array not Multi-Colour Graphics Adaptor. I have also seen the VGA referred to as the Versatile Graphics Adaptor in Penfold's book; Upgrading and Repairing PC's. When I saw this in Mr. Penfold's book myself and my colleagues could not restrain out laughter. However, to find he same mistake in a magazine which ought to know better is quite outrageous. I believe the correct definitions are:

MDA	Mono Display Adaptor
CGA	Colour Graphics Adaptor
EGA	Enhanced Graphics Adaptor
MCGA	Multi-Colour Graphics Array
VGA	Video Graphics Array

Could I suggest that you specifically mention when

reviewing PC graphics software, whether or not the software supports the higher resolutions offered by the different graphics adaptors (as opposed to emulation of lower screen modes). for example, Easy-PC claims to support CGA, EGA and VGA. However, the highest mode that the software operates in is EGA. Thus on a PC equipped with VGA, the graphics adaptor runs in EGA mode.

A second discrepancy I have encountered is that Ian Poole refers to MOS (in his article - The Integrated Circuit Story) as meaning Metal On Silicon. Doesn't MOS refer to Metal Oxide Semiconductor? Or am I missing the point?

After getting used to the of format magazine, I am intrigued to know why you have changed the layout? Otherwise, well done!

Phillip J Turner
Tredworth
Gloucester

After looking through quite a few mags and dictionaries, it seems that you are quite correct with your definitions of PC display adaptors.

MOS strictly speaking stands for Metal Oxide Semiconductor which refers to oxides of iron, zinc, cobalt and nickel. However, as you rightly say, it is also generally used for metal oxide silicon. The construction of the latter is a series of layers of silicon, silicon oxide and metal (Al or Si) and could be referred to as Metal On Silicon.

With regard to the redesign of PE, we thought it was time that a magazine about modern electronics should have an up-to-date look.

Proportional Error

At the risk of becoming a pain in the posterior could I point out an innacuracy that occurred in the article on the resistor in the April issue of PE.

The formula for relating

resistance to resistivity is incorrect and should read

$$R=rl/a$$

where l is the length of the conductor in metres.

I would quibble over the phrase "...(R) of a conductor is proportional to its cross sectional area" It is actually inversely proportional as the formula immediately shows.

The value for the resistivity of silver shown in the table is incorrect and should, presumably, read 0.95×10^{-8} .

Andrew Chadwick
Hull

You are correct about the resistivity it seems that the = symbol should have been α . However, I would say that proportional without a qualification can refer to inversely or directly, it is still proportional.

On checking the value for silver, it seems that the symbols Ag and Hg were mixed up. The resistivity for the first is 1.59×10^{-6} and the latter is 95.7×10^{-6}

Correct Symbol?

I noticed that in your newly designed Practical Electronics that the symbol for a resistor has been changed from the standard 'squiggle' to a square box. As a reader of long standing, I am rather confused by this change from what I thought was the standard engineering symbol. I don't mind the new design but could you possibly revert back to the old symbol?

John Bilson
Wirral
Cheshire

Looking through various reference books reveals that both the 'squiggle' and the block are standard symbols. The block is easier to draw so I'm afraid that we will be staying with it for the foreseeable future. ■

What's In The Bin?

Chip Count

The new 87C52 from Signetics doubles the memory size of the industry standard 80C51 microcontroller offering 8kbyte EPROM and 256 bytes of RAM. There is also an extra 16-bit timer, giving a total of three, and the device is available in either 16MHz or 20MHz versions.

Signetics has also announced that it will be producing a 4Mbit CMOS EPROM. The 27C240 is organised as 256kx16 bits for use with 16-bit and 32-bit systems. With access times of 150ns and 200ns and a standby power consumption of 100µA the chip comes in both 40-pin dual in line (DIL) and 44-pin plastic leaded chip carriers (PLCCs).

For more information contact Signetics at 811 E. Arques Avenue, PO Box 3409, Sunnyvale CA 94088-3409, USA.

Designed with a minimum footprint of 78x70mm, the new graphics LCD family from Trident Microsystems provides displays in sizes from 80x32 to 240x128 pixels. Many of the units have on-board controllers and static RAM (SRAM) to simplify interfacing. For more information contact Trident Microsystems on 0737 765900.

Offering a successive approximation ADC (analogue to digital converter), a 5.25V reference, clock oscillator and microprocessor interface, the MAX 173 takes an input voltage in the range 0 to 5V. The MAX177 offers a similar spec but has input sample and hold, a 2.5V input range and an 8.33µs

The days of the bench full of test equipment could soon be over if the new Global VIP is anything to go by. It emulates a 4.5 digit multimeter, chart recorder and data logger on any IBM-PC/XT/AT/386 EGA compatible computer system. The single card simply plugs into a spare socket and its accompanying software provides voltage measurement in ranges from 0 to 1000V and current from 0 to 10A in both AC and DC. Resistance can be monitored up to 20MΩ and capacitance to 2µF.

All calibration settings are blown into EEPROM at the factory but can be altered as necessary. Any data recorder can be output in comma delimited format allowing it to be sent to a printer or analysed in other software packages such as spreadsheets, databases and wordprocessors. The only drawback is the price of £499. However, the same system (or very similar) is available from Alpha Electronics at £495. For more information, contact Global on 0978 853920 or Alpha on 0942 873434.

conversion time. Both give 10-bit conversions and require 5V, -12 or -15V supplies. For more information contact Kudos Thame on 0734 351010.

The PCM1750 is an

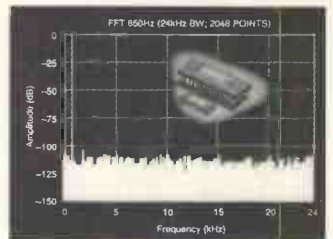

ADC aimed at the audio market. It offers two converters giving 18-bits resolution each, an internal 2.75V reference and internal sample and hold. Conversion times of 4.5µs permit up to four times over-sampling in the audio bandwidth (0 - 20kHz). The device will accept two ±2.75V audio inputs and outputs capable of driving TTL loads. As a companion to the chip, the DF1750 is a filter which takes the digital output of the PCM1750 and suppresses any signal outside the audio passband. This increases the signal to noise ratio by approximately 6dB. For more information contact Burr Brown, PO Box 11400, Tucson AZ 85734, USA.



Suckered Up



The Pen-Vac is a miniature vacuum pump designed mainly for picking up components, specifically SMDs. It weighs less than 1oz and is available with a variety

of probes. It is available from OK Industries, Barton Farm Industrial Estate, Chickenhall lane, Eastleigh, Hants, SO5 5RR on 0703 643279.

With the rise and rise of notebook personal computers, the time has come for a chip set that reduces all of the functions of a PC/AT laptop into as few devices as possible. The VL82C310 SCAMP-LT provides control for the CPU, DRAM (up to 16M bytes) and AT bus interface. The VL82C107 SCAMP combination chip is a keyboard/mouse controller, real timer clock

Soft Chip

and DMA decoder. The VL82C312 SCAMP power management unit (PMU) is what makes the whole system as portable as possible since it reduces power consumption by monitoring all activity to detect when certain parts of the system are unused so that they can be powered down. The chip also provides a range of glue functions such as chip selects and interface logic functions that weld the system together. The chips are intended for use with 80286 and 80386SX systems with clock speeds from 10 to 20MHz. For more information, contact VL82CNB, VLSI Inquiries Dept. 134, 200 Parkside Drive, San Fernando CA 91340 USA.

Devices & Tools



A set of new tools has just been announced by Ungar. This includes a new cutter design which cuts with a shearing motion rather than the standard crush method and minimises component shock and operator force - reducing the possibility of Carpel Tunnel Syndrome, paralysis of the fingers due to pressure in the palm of the hand. For more information contact Ungar Eldon Industries UK, 0462 814914

The model 604 Minilab from Tandem Technology provides seven basic bench top instruments in one enclosure. These are a

To guard against microprocessor crashes, Dallas Semiconductor has produced the Micro Softener. Compatible with the 8086 (V40), 6303, 68HC11 and the 80C196 the chip uses a lithium battery to provide uninterruptable power for the following functions: power monitor, watchdog timer, non-volatile controller, address decoder, bootstrap ROM, 4x8-bit parallel I/O ports, dual-port register file and interrupt controller. The idea is that if the power is removed from the system, the softner chip holds the status and allows the system to continue when power is restored, no matter how long the stoppage. The soft aspect refers to the built in bootstrap ROM which can be reprogrammed via a serial port from the PC. This means that

upgrades can be installed at any point during the system's lifetime or personalised at purchase time to 'load and go'.

A voltage detector is used to monitor the power level and the chip can initiate a call for help if trouble occurs. The idea is that the system can be connected to a modem and when anything untoward happens, a central controller is dialled up and test software downloaded to check out the problem. The memory and microprocessor execution times can be monitored so that any problems can be pinpointed and, possibly, fixed.

The Micro Softener allows increased reliability in situations where power fluctuations are common and provides all of the functions of a peripheral interface chip as well.

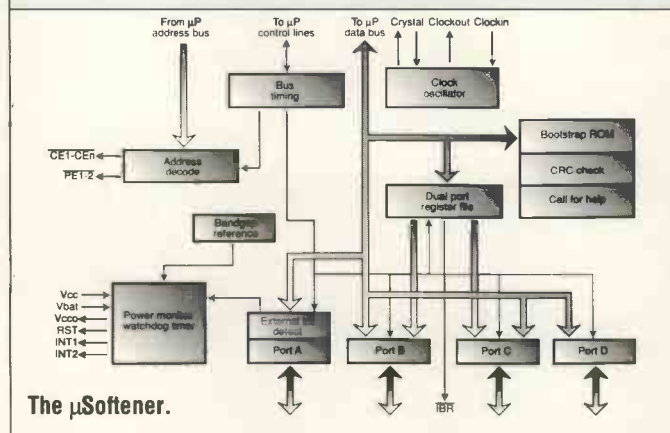

13MHz sweep function generator, frequency counter, power amplifier, ±15V 1A bipolar power supply, +15V and -15V isolated dual power supply, 5V 3A power supply and a true RMS 3.5 digit multimeter, all powered by a built-in mains power supply. measuring 328x240x175mm and weighing

6kg, the unit costs £845 and is available from Tandem Technology, Tel 0243 532766.

A new low cost DMM (Digital Multi Meter) from Global specialities sports an LCD display, DC voltage measurement to 1000V, AC to 750V and current measurement to 10A. Resistances can be

measured to 2MΩ and visual and audible continuity plus diode tests are available. Weighing only 180g and costing £49.95, the 735 is guaranteed for 12 months. For more information phone Global on 0978 854564.



The Tek 404 from the The Instrument Centre is a continuity tester with built-in protection. For resistance ranges from 0 to 170kΩ the audio output is used with a visual display for 0 to 8k. The probe tip voltage is 9V at 5mA and the audio frequency is 2.8kHz. Supplied with a two year guarantee, the TEK 404 costs £24.95 and is available from TIC on 0633 280566.

The Hitachi V209 is a battery powered oscilloscope now available from Thirlyby Electronics. Weighing 5.3kg it has a bandwidth of 20MHz, a vertical sensitivity of between 5mV and 5V per division and timebase speeds from 0.5μs/div and 0.2s/div. A built-in TV sync separation circuit allows stable observation of both horizontal and vertical waveforms.

Another scope from Tandem Technology is the BWD Powerscope II which offers safety at high voltages, up to 15KVA or 100A. All controls and the case are insulated and the input terminals are shrouded

and recessed. Four 30MHz differential input channels are provided with input sensitivities between 20mV/div and 15kV. As well as being safe, the unit is portable and can be powered from AC or DC between 90V and 264V from 45 to 440Hz, or its built-in battery pack. For more information tel 0243 532766.

A new enclosure is



now available from Bopla. Named Elegant and moulded from high impact polystyrene with a two tone grey finish, it is made as two halves that can be screwed together. All sizes in the range have protection up to IP 54. For more information, contact Bopla on 0296 399 999.

Computers



Finding the right part usually means looking through a whole selection of catalogues, listings, files, and such. However, Burr-Brown has now launched its electronics selection guide on disk for IBM-PC compatible computers. It holds more

In Control

Hitachi recently announced the launch of its new H series of micro-controllers. Available in 8, 16 and 32 bit sizes there are two main sub-families, the 300 and 500. The first offers 57 simple instruction types in a RISC (Reduced Instruction Set Computer) type format, including fast multiply and divide functions. There is a maximum of 64Kbytes of address space with three operating modes which allow internal ROM (16kbytes) and RAM (512 bytes) to be enabled or disabled where necessary. Also built into the device are a 16-bit free running timer, an 8-bit multifunction timer, pulse width modulation timer (PWM), serial interface offering synchronous and asynchronous operation,

an 8-bit ADC, nine I/O ports giving 57 bi-directional and 9 input only pins, clock generator and nine external interrupts, all of which comes in an 84-pin package.

The 500 series is similar to the 300 but is built around a 16-bit internal architecture that supports a highly orthogonal instruction set and address space up to 16Mbytes.

Operation speeds of up to 10MHz are possible with throughput increased by the majority of instructions being only 2 bytes long. Power consumption is typically 12mA at 6MHz with low power sleep modes available to save 30% of operating current. Standby mode, which retains all of the internal registers, uses only 0.01µA.

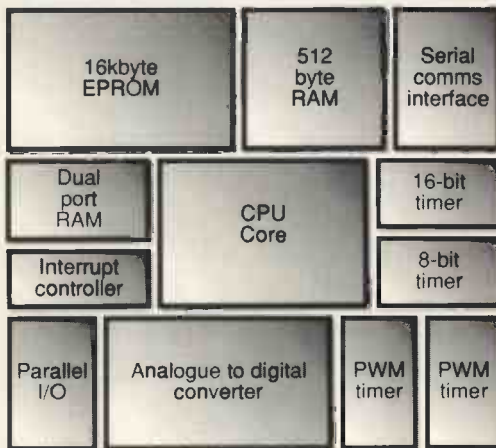

The main components of the H8/330

than 1250 current component models and allows quick access via a menu system to eleven product categories, including analogue functions, ADCs, DACs, DC/DC converters, instrumentation amplifiers and voltage to frequency converters. Updates can be

downloaded from the electronic bulletin board service so that the catalogue can be kept up to date.

If you think that your computer is at risk from static, a new mat from OK industries could be the answer. Designed to be placed under the

keyboard, it connects to ground via a lead so that any charges built up by rubber shoes on nylon carpets are drained away to earth. For more information, contact J. Dornan Industries UK Ltd. on 0703 619841.

Help is at hand for anyone who wants to know more about CAD systems. Pink Software has released Teach Yourself CAD, 30 pages of information on disk along with Turbocad. Covering drawing lines, understanding X and Y coordinates, relative and absolute positions, snapping, dimensioning, shading, text, mirroring, filleting and using symbols, the package also allows the user to evaluate Turbocad. Priced at £9.99 (inc VAT and pp), the disk works on any IBM-PC/XT/AT compatible with hard disk, 640k or RAM, DOS 2.0 or later and a wordprocessor. For more information contact Pink Software on 071 259 2100.

Events

The All Formats Computer Fair will be held on 21st April at the Birmingham Motorcycle Museum, Coventry Road, Solihull, West Midlands (J6 of the M42 where it meets the A45). Tickets are available from John Riding on 0225 868100.

CD-ROM Europe 91 will be held at the Novotel in Hammersmith, London on 21-23 May. The exhibition is dedicated to CD-ROMs and features the latest hardware, software and multimedia. For more information, contact Jane West on 0733 60435. ■

Finally... an exceptional PCB and Schematic CAD system for every electronics engineer!

BoardMaker 1 is a powerful software tool which provides a convenient and professional method of drawing your schematics and designing your printed circuit boards, in one remarkably easy to use package. Engineers worldwide have discovered that it provides an unparalleled price performance advantage over other PC-based systems.

BoardMaker 1 is exceptionally easy to use - its sensible user interface allows you to use the cursor keys, mouse or direct keyboard commands to start designing a PCB or schematic within about half an hour of opening the box.

HIGHLIGHTS

Hardware:

- IBM PC, XT, AT or 100% compatible.
- MSDOS 3.x.
- 640K bytes system memory.
- HGA, CGA, MCGA, EGA or VGA display.
- Microsoft or compatible mouse recommended.

Capabilities :

- Integrated PCB and schematic editor.
- 8 tracking layers, 2 silk screen layers.
- Maximum board or schematic size - 17 x 17 inches.
- 2000 components per layout. Symbols can be moved, rotated, repeated and mirrored.
- User definable symbol and macro library facilities including a symbol library editor.
- Graphical library browse facility.
- Design rule checking (DRC)- checks the clearances between items on the board.
- Real-time DRC display - when placing tracks you can see a continuous graphical display of the design rules set.
- Placement grid - Separate visible and snap grid - 7 placement grids in the range 2 thou to 0.1 inch.
- Auto via - vias are automatically placed when you switch layers - layer pairs can be assigned by the user.
- Blocks - groups of tracks, pads, symbols and text can be block manipulated using repeat, move, rotate and mirroring commands. Connectivity can be maintained if required.
- SMD - full surface mount components and facilities are catered for, including the use of the same SMD library symbols on both sides of the board.
- Circles - Arcs and circles up to the maximum board size can be drawn. These can be used to generate rounded track corners.
- Ground plane support - areas of copper can be filled to provide a ground plane or large copper area. This will automatically flow around any existing tracks and pads respecting design rules.

Output drivers :

- Dot matrix printer.
- Compensated laser printer.
- PostScript output.
- Penplotter driver (HPGL or DMPL).
- Photoplot (Gerber) output.
- NC (ASCII Excellon) drill output.

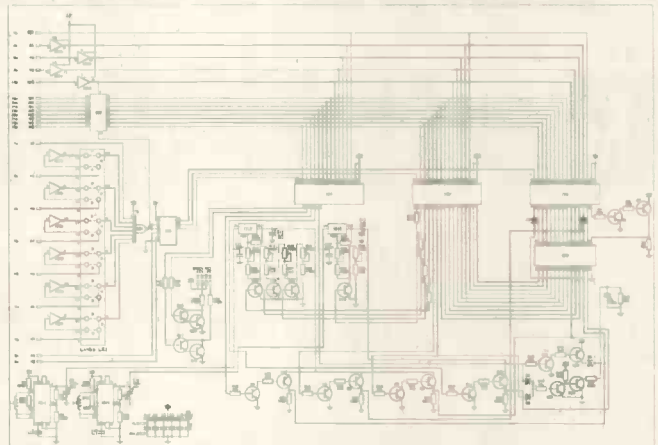

Produce clear, professional schematics for inclusion in your technical documentation.

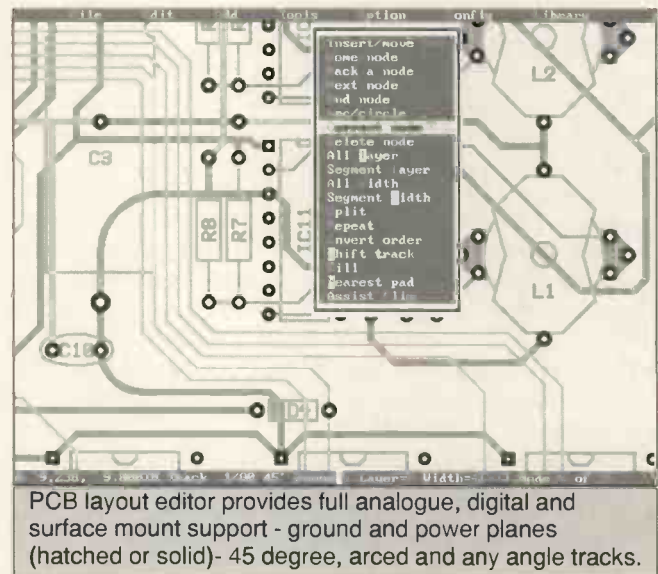

PCB layout editor provides full analogue, digital and surface mount support - ground and power planes (hatched or solid)- 45 degree, arced and any angle tracks.

£95

Despite its quality and performance, BoardMaker 1 only costs £95.00 + £5.00pp + VAT. Combine this with the 100% buy back discount if you upgrade to BoardMaker 2 or BoardRouter and your investment in Tsien products is assured.

Don't take our word for it. Call us today for a FREE demonstration disk and judge for yourself.



tsien

Tsien (UK) Limited
Cambridge Research Laboratories
181A Huntingdon Road
Cambridge CB3 0DJ
Tel 0223 277777
Fax 0223 277747

All trade marks acknowledged

Philips Set To Storm The HiFi World

The Digital Compact Cassette, recently shown at CES in Las Vegas, could prove to be the undoing of DAT. Ian Burley explains how it works and how it shapes up.

If you stopped the average person in a street using a Walkman personal stereo and asked them who invented the cassette mechanism, the chances are they wouldn't know. It's actually 27 years since the Compact Cassette was introduced by Philips and it sparked off a revolution in domestic audio all around the world. A few interesting statistics show how lucrative the audio cassette market is - 2.6 billion cassettes are sold every year and the figure is growing steadily, 60% of these cassettes are blank, the rest pre-recorded.

However, time moves on and digital technology has a firm grip on the future of audio. In the early 80s Philips and Sony collaborated to produce the digital compact disc. Digitally coded music is hiss-free, has a dynamic range far exceeding even the best domestic analogue

tape players and unlike records, there aren't any crackles and scratches. Despite its relatively high cost, the CD is gradually killing the vinyl record industry.

The Japanese Angle

A Sony-led consortium of mainly Japanese electronics companies went on to develop digital audio tape (DAT) with the expectation that it would replace the venerable compact cassette as the world standard for high quality personal and even professional recording. DAT has an audio capability comparable with CD and it is quite possible to make virtually perfect copies of CDs with it. Unfortunately this was to prove its undoing.

The music software publishing industry stopped DAT in its tracks, claiming that the threat of music

piracy was unacceptable. Hardly anybody would produce pre-recorded DAT albums and so volume sales of DAT recorders never got off the ground. Another reason why DAT wasn't exactly popular with the software industry was that DATs are difficult and expensive to duplicate in high volumes.

Mechanically speaking, DAT recording technology can be loosely described as a miniaturisation of the video recorder. A helical-scan spinning drum contains the record and playback heads. This prevents high speed tape duplication and the mechanisms themselves are relatively expensive and fragile. DAT was ready to go five years ago but even after the DAT lobby agreed to limit its copying capability with a serial copy management system, to prevent copies from being copied, support for DAT remains weak.

Philips says it was clear quite early on that DAT was going to be a loser - a comment from one of the key development contributors to the DAT standard! The two biggest growing markets for audio cassettes are personal stereos and in-car Hi-Fi Philips points out that you simply can't build affordable DAT personal stereos. It also questions whether DAT is robust enough to survive the shock, vibration-prone and sometimes extremely hot environment of the automobile. But above all that, Philips believed it could develop a high quality digital cassette that had compatibility with everyday audio cassette tapes. Apparently most households have libraries of between 50 and 60 cassettes, with many well above that figure. That collection of

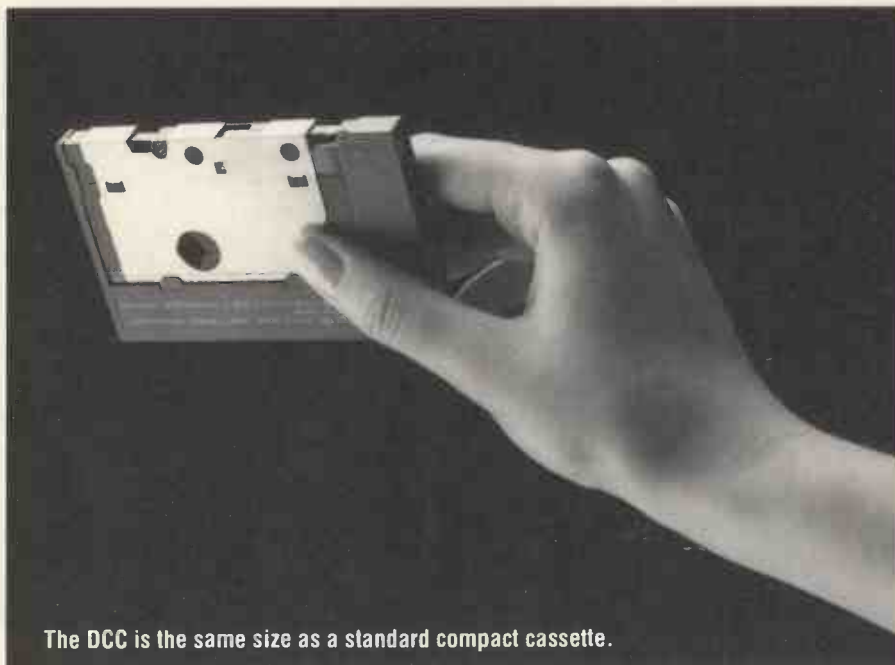

The DCC is the same size as a standard compact cassette.

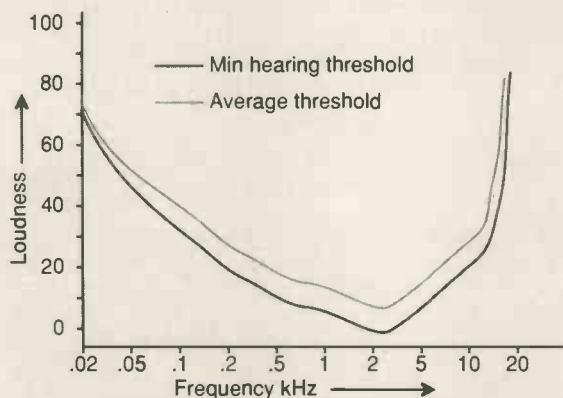

1. The ear is more sensitive to middle frequencies and varies from person to person.

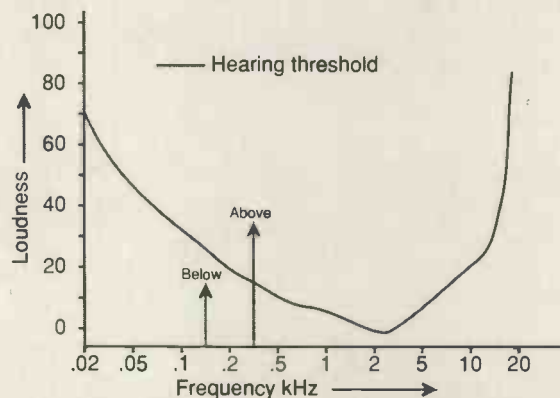

2. Only sounds above the threshold can be heard.

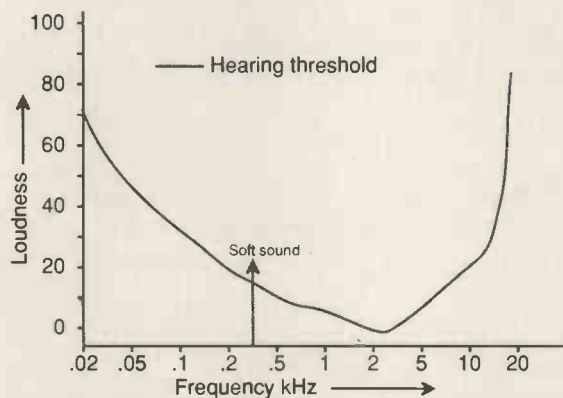

3. The soft sound is audible since it is above the threshold.

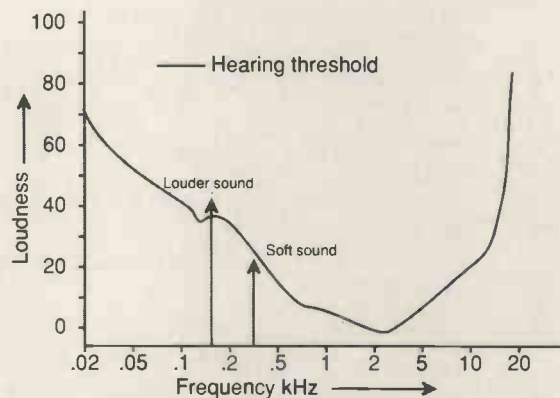

4. The loud sound increases the threshold and masks the soft sound which no longer needs to be recorded.

billions upon billions of tapes around the world is going to be a major marketing advantage in favour of the new Philips system.

So, the Philips Digital Compact Cassette, or DCC, was unveiled earlier this year at the Consumer Electronics Show in Las Vegas. What Philips showed was a minor technological marvel and unwelcome news to the struggling DAT.

What Is DCC?

A DCC cassette doesn't look like a conventional cassette although it has the same dimensions. On the outside there is a thin sliding metal dust guard, rather like that on a 3.5 inch floppy disc. One side of the cassette is completely flat and in commercial form would feature album/inlay graphics, as would the spine. On the other side the tape spools are exposed by sliding the guard to one side as would happen when the DCC is inserted in a player. The action also exposes the tape ready for the capstan and pinch-rollers and of course the

record/playback head. The DCC shell has been designed to withstand high temperatures, especially important in car cassette players.

DCCs can only be inserted one way around. Auto-reverse is a standard specification and any pretty graphics on the case will be on full display when the cassette is in use. Like video tapes, the spools are locked when out of the machine to prevent unspooling and potential jamming. The tape itself is the same width and has the same transport speed as ordinary cassettes.

The first DCC tapes will be 90 minutes long at 45 minutes per side and will be known as D90s - there is also provision for a D120 tape (60 minutes per side). Philips says the tape formulation is nothing exotic, which cannot be said for the metal particle systems used in DAT.

The Business End

Things start looking clever when you look at the record/playback head. Borrowing technology from disk drive manufacturers, the head

surface is manufactured on ferrite wafers using thin film techniques in similar fashion to silicon chip production. The composite DCC head has no less than 9 tracks to deal with; 8 audio data tracks and one ancillary track which deals with programme indexing and even real-time textual playback for things such as *Karaoke* functions where you can read the words of a song as they are being sung by the performer.

The same head incorporates a pair of conventional analogue stereo tracks for playing back standard cassettes. At present there is no mention of incorporating an analogue record facility. The rest of the tape transport mechanism is fairly standard. Philips notes that despite the apparent complexity of the head, digital play azimuth tolerance is actually less exacting than in analogue playback.

Now onto the cleverest bit of all - how to stuff a digital audio signal onto a tape which by rights only has one quarter the bit-wise capacity at 384kbits per second. The simple answer is that you don't and before

Magnetic tape – a brief history

Magnetic tapes are basically made from a plastic strip coated with a magnetically sensitive material. The problem of making this to a reliably high standard is something that has plagued the audio industry for years.

The range of frequencies or bandwidth that can be put onto a tape is determined by the number of signal transitions that can be resolved per unit length. The first tape recorders built in 1900 by Valdemar Poulsen used a steel strip which moved at high speed past the recording head and was able to resolve a wavelength of around 1mm. At the end of World War 2, BASF and AEG in Germany had started to develop paper strips coated with thin layers of magnetic iron dust – an idea patented by Fritz Pfleumer of Dresden in 1928. Unfortunately, pure iron dust had the disadvantage of rusting during use and was also capable of exploding during manufacture. The wavelength that could be impressed on tapes of this type was around 100 micrometres.

Eventually, Gamma Ferric Oxide was used to provide a reasonably reliable coating. Research during the 1960s in the US by Du Pont came up with

chromium dioxide which offered higher coercivity and better temperature and pressure stability. Coercivity is the amount of magnetic flux needed to return a magnetic material from saturation to zero. As the size of the magnetic particles falls and the recorded wavelength reduces, the amount of coercivity of the magnetic media must be increased so that neighbouring particles don't demagnetise each other.

The only Japanese company to take up a license to make Du Pont's tape was Sony with the rest of the Japanese electronics industry deciding to go its own way. By 1973 TDK had developed Avilyn which put small quantities of cobalt into a surface of acicular gamma ferric oxide to give an even higher coercivity than chromium oxide.

With the limits having been reached for chrome and cobalt technologies, a new technique had to be developed for 8mm video and DAT which required very short wavelengths to be put onto the tape. The solution lay with pure iron metal tape which can be manufactured in two ways. The first uses a plastic base film which is coated with acicular

particles of pure metal. The second evaporates the metal in a vacuum and deposits it on a chilled plastic base film. This results in a coercivity of 1000 oersted and requires high very powerful magnetic heads to magnetise it.

The two main types of head are Sendust coated or amorphous metal. The first uses a standard ferrite head covered with a sputtered Sendust layer. Amorphous metal is made by heating the material up to its melting point and then cooling it in around 1000th of a second. This causes the metal to have a non-crystalline structure which is corrosion resistant, hard and able to deal with very high magnetic fields. The wavelength capability of modern metal tape is now less than one micrometre (around 0.7 μ m). New technologies of non-crystalline cobalt nickel alloy deposited on thin films give layers less than 0.5 microns thick which allows more tape to be packed onto a spool, increasing the possible recording time of a cassette. The drawback is that thin coatings can't cope with low frequencies which is fine for video and digital but not for analogue systems.

you say, aah – it's compressed, that's not the case either. In fact Philips has developed a code translation system which eliminates redundant data from the incoming signal. This is based on the physiological fact that human beings can't hear everything which a conventional digital source, like DAT or CD, plays. The primary objective of digital recording is to preserve as accurately as possible the signal from something like a microphone, but in digital form. The theory goes that human ears can't hear sound components which are masked out by louder ones. For

example, if you can hear the birds twittering outside through an open window and then you gradually turn your HI-FI volume up, eventually you will only be able to hear the HI-FI playing.

Philips had to develop an encoding system not by relying on matching scope readings of the source and recorded signals but by letting expert human listeners make comparisons. In other words, the way our ears and brains manage sounds has been mimicked and burned into chips which form what's known as PASC or Precision Adaptive Sub-band Coding.

PASC works by splitting the complete incoming digital signal into 32 sub-bands. Each sub-band is coded as a bit value between 0 and 15 according to the PASC reference which is modelled on the human ear.

Whereas digital signals would always use 16 bits of data space, PASC allocates none at all for bands with no signal (coded '0') up to 15 for the maximum signal content. The average allocation is 4 bits per sub-band, a quarter of the conventional space required by a full digital signal.

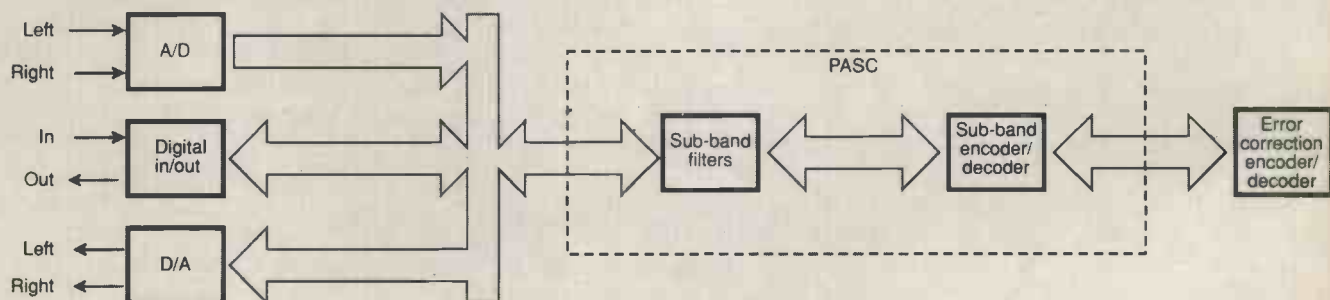

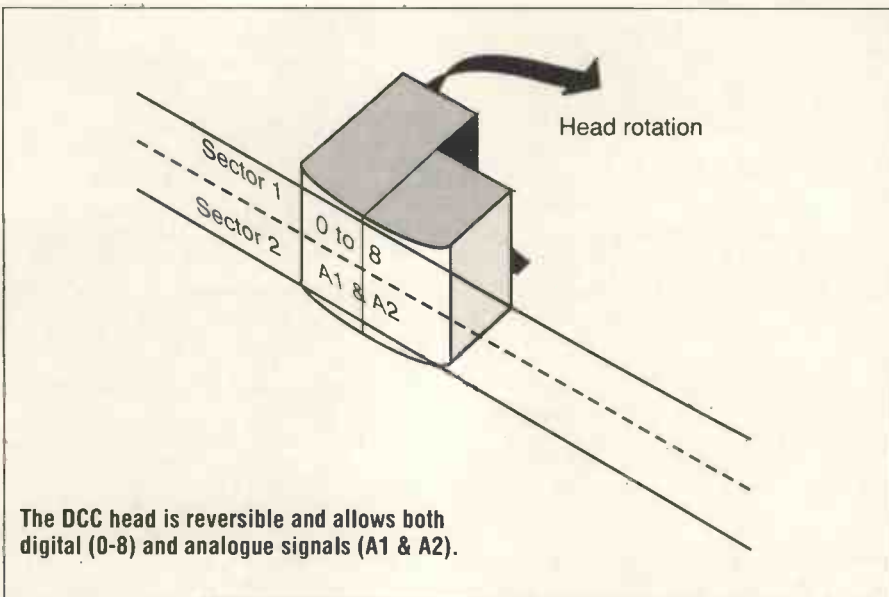

The DCC head is reversible and allows both digital (0-8) and analogue signals (A1 & A2).

Easy On The Ear

The PASC firmware has been modelled from scratch on human responses and fine-tuned by extensive panels of listeners over an 18 month period. Philips says that its expert panels can't tell the difference between DAT and CD sources and DCC recordings. As all humans are slightly different and some people can be extraordinarily sensitive, it's likely that some extreme HI-FI-buffs may not be at home with DCC but the fact is that there is virtually no hiss, the dynamic range is way above analogue cassette tape at 105dB and total harmonic distortion is better than 93dB.

In the early days there were many sonic inaccuracies in the coding. Listeners complained of instruments wandering around the sound stage and other spatial problems, but these have now been defeated, according to Philips.

DCC is now at the production engineering stage and Philips confidently predicts DCC players will start to appear towards the end

of next year. Initial prices are expected to be in the £250 region, at least half that of comparable DAT players. Most of the signs are good for DCC. Philips itself is a big audio software supplier so support from the record industry should be more easily achieved than with DAT. Backwards compatibility with

standard audio cassettes is a very big plus and commercial tapes will be relatively cheap to duplicate. Sound quality will be much better than ordinary tapes and Philips happily states it is comparable with CD.

The Downside

On the negative side, Philips as a worldwide electronics group is in serious financial trouble having just announced £1.4Bn in losses. With failed innovations like LaserVision and the V2000 video format behind it, some pundits say Philips isn't up to exploiting its technical prowess. Sony has hit back with a simplified DAT mechanism which is cheaper, though not as cheap as DCC. Luckily Philips appears to have a Japanese Fairy Godmother in the form of Matsushita - Japan's largest electronics group and the force behind names like Technics and Panasonic. Unless something very silly happens, we should all be taking DCC cassettes for granted in 27 years time. ■

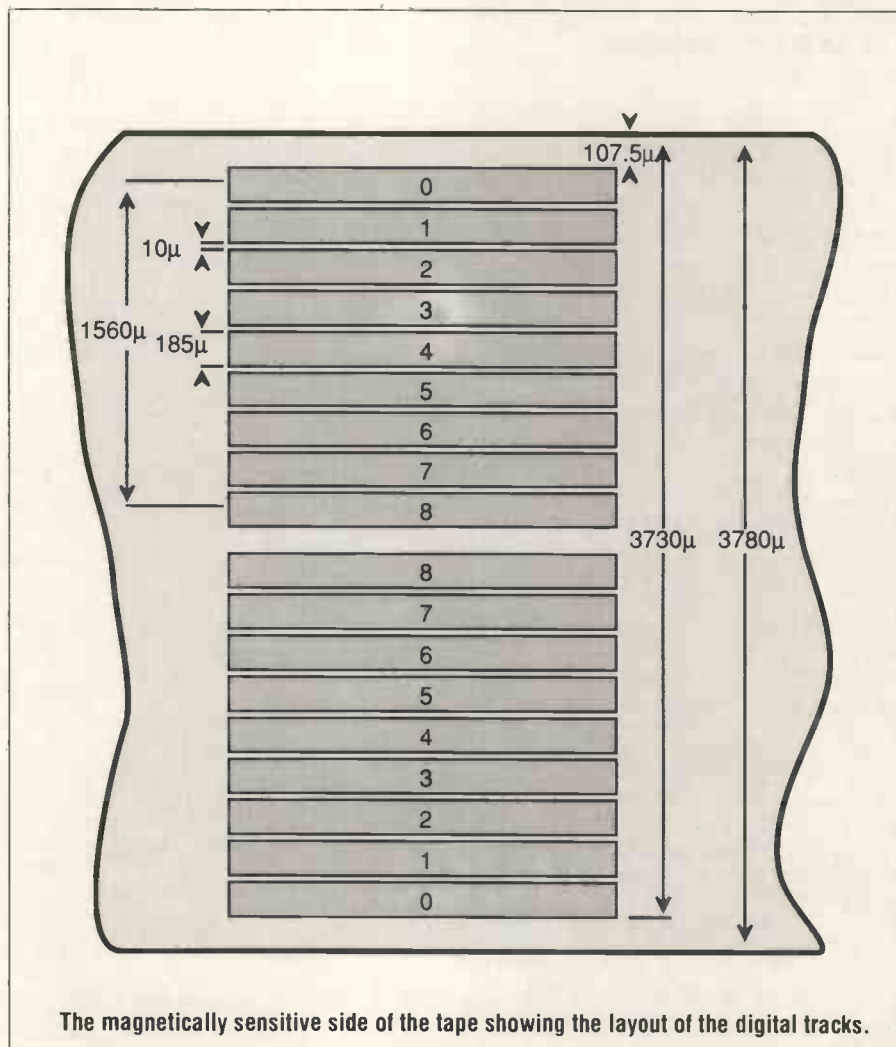
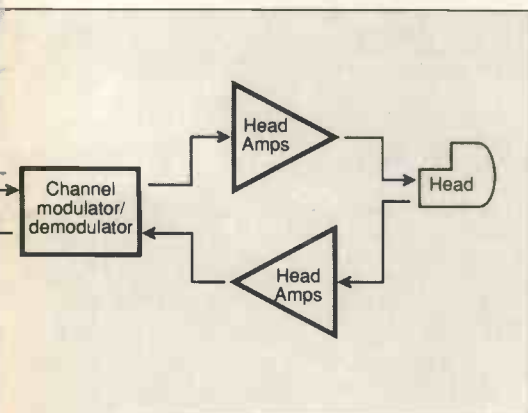

The magnetically sensitive side of the tape showing the layout of the digital tracks.

Shoot Your TV With A PC

John Becker shows how a PC-compatible computer can snap a picture from the TV, load it into memory and modify it from software.

Here's a project that will provide a lot of interest for PC owners who enjoy programming and messing around with graphics. It captures pictures from TV sets and stores them on disk so that they can be manipulated and displayed by computer program at a later date.

Using a high speed analogue to digital converter (ADC), the unit samples the TV picture signal and stores the data in on-board memory. Once captured, the picture data is transferred to the computer's disk drive under control of a Basic program. It can then be re-imported and manipulated to extract and modify picture details as desired.

In The Frame

The start of a TV picture is signalled by a pulse which is used to trigger and synchronise the unit with the TV. In the UK, the TV video bandwidth is nominally 5.5MHz and the picture is made up of 625 lines, of which only 575 are visible. The complete picture is transmitted in two sections, made up from odd and even numbered lines and interlaced to form the final image. It takes one twenty-fifth of a second to transmit both. The unit has been designed to record just one part, ignoring whether it consists of the odd or the even lines.

GW-Basic, the dialect in which the software was written, allows for the plotting of a graphics picture consisting of 199 lines by 319 columns. To simplify the unit's memory and control requirements, a recording capacity of 65536 (64K) samples has been allowed for. By setting the sampling rate to 4MHz, each sampled TV line is represented by 256 samples. This allows 256 TV lines to be recorded with a reasonable degree of definition. Since the usable portion of each part of the transmitted picture consists of 287 lines, only 31 lines are lost. Of the 256 lines recorded, any consecutive grouping of 199, or less, can be displayed simultaneously.

The recorded data is a numerical representation, from 0 to 63 (six bits), of the picture signal amplitude sent to the TV's screen. When sent to the computer screen the varying amplitudes can be represented as changes in colour. The number of colours available will depend on the monitor screen and, possibly, the software used. Monochrome monitors can be used with the unit using the recorded data to generate high contrast displays by showing the image as straight black and white.

The pictures generated may be used as interesting screen displays or written to a printer. Experienced PC users will also be able to

incorporate them in a wide variety of graphics applications.

The unit should work with any standard IBM compatible computer and uses the standard interface slots. Unfortunately, it is not practical to use this unit to capture pictures from colour TVs. Whereas a monochrome TV video signal can be tapped at a single point, a colour TV video signal is split and sent to several cathodes on the tube.

Stashing The Numbers

Fig.1 and Fig.2 show the block and main circuit diagrams for the project.

In Fig.2, the 4MHz recording control clock generator is formed around IC3e. The clock signal triggers the memory address counters and the digital conversion of the video data.

The video signal is brought into IC7, a 6-bit high speed flash ADC chip. IC7 has two reference inputs, of which one is tied to the +5V line and the other set at about 0.5V by R4. On receipt of a clocking pulse, the chip converts analogue signal input levels which lie within the set range into an equivalent digital output on pins B1 to B6. These lines are connected to the data inputs of two 32Kbyte memory chips, IC8 and IC9, and to a tri-state octal gate, IC10. The overflow (OFL) output of IC7, although connected to the memories and gate, plays no active part in this circuit.

The memory address at which each sample is stored is determined by the twin counters IC5 and IC6. These are connected in series and are clocked at the same rate as the ADC. Between them, IC5 and IC6 provide access to all memory

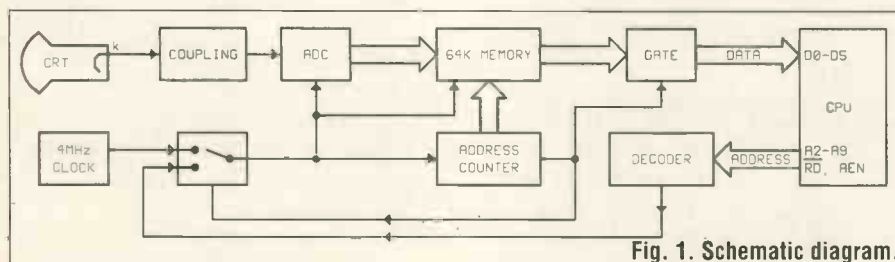

Fig. 1. Schematic diagram.

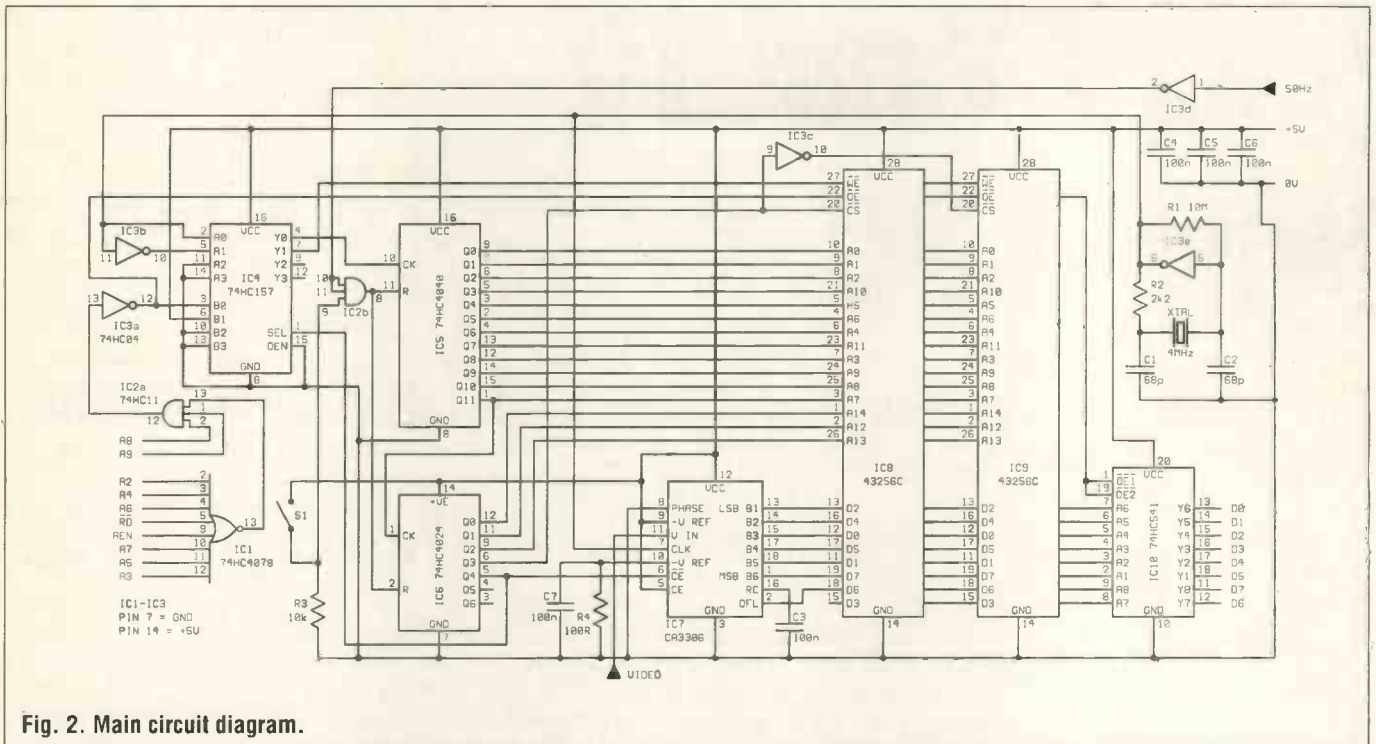

Fig. 2. Main circuit diagram.

address lines A0 to A14. The selection of which memory is active is controlled by the Q3 output of IC6. This is the equivalent of address line A15. When low, A15 causes IC8 to become active by taking its CS (chip select) pin low. The CS pin of IC9 is also controlled by A15, via the inverter IC3c. Thus IC9 is only active if A15 is high.

Storing The Image

To record a picture, S1 is closed, allowing 50Hz field pulses from the TV to pass through the AND gate IC2b and repeatedly reset the counters IC5 and IC6. Between each reset pulse, the counters and the ADC are clocked at the full 4MHz rate and each byte of data is recorded by the selected memory. When S1 is opened, the last recorded picture remains in memory. During the first 32768 counts following the end of the reset pulse, IC8 records the ADC data. When A15 goes high, IC9 records the next 32768 data samples. On count 65537, the Q4 output of IC6 (A16) goes high and will remain so for the next 65535 counter steps. The A16 line controls the enabling of IC7 and the gated routing of the clock signal source. When high, A16 disables IC7, putting its outputs into a high impedance state, so effectively removing them from the memory data lines. The high state of A16

also switches the multiplexing gate IC4 so that the clocking signal from IC3e is no longer routed to the counter chain via IC4 A0/Y0. Instead, the clocking can now come from the computer, via IC4 B0/Y0.

IC4 also controls the Write Enable (WE) pins of IC8 and IC9. In record mode, IC4 routes the 4MHz clock signal inverted by IC3b, via A1/Y1 to set the memories into their Write state when the clock phase is low. Only the memory selected by A15 will be affected. When A16 is high, IC4 selects the B1/Y1 path, so setting and holding the WE pins of both memories for Read mode.

Once A16 has been set high and the B-path of IC4 is open, the computer can step the counters through all 65536 addresses and read the memory contents at each address.

Consideration was given to using the computer keyboard to trigger the unit's sampling routine. It was decided to use a separate external switch since this allows a picture to be snapped from the TV even when in the middle of programming modification lines for other sampled pictures.

Computer Connection

The circuit has been designed to be read from computer memory map location hex \$0300. Via one of the computer's expansion slots, the

circuit is directly connected to the address, data and control buses. Decoding of the address bus is performed by the octal NOR gate IC1 and the triple-input AND gate IC2a. IC1 requires that address lines A2-A7, AEN and the RD lines should all be low. When this condition prevails, IC1's output pin 13 goes high. This provides one input for IC2a. When address lines A8 and A9 are also high, IC2a is activated and its output goes high. (Observant readers will spot that in fact IC2 will be triggered when the computer reads from any of locations hex \$0300-0303 since address lines A0 and A1 are not used.)

Two functions are controlled by the action of IC2a being triggered. The output from IC2a pin 12 is inverted by IC3a whose negative-going output triggers the clock input of IC5, stepping the count on by one place. The same logic-low condition also activates the output enable (OE) pins of the memories and of the data gate IC10. Consequently, each time the controlling software calls the read \$0300 command, consecutive memory data from the unit will automatically be presented to the computer data lines. When the computer is not reading via \$0300 (or \$0301-0303), the outputs of the memories and IC10 will be in a high impedance state.

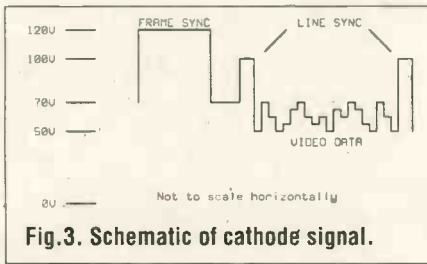

Picture Source

The TV set for which the unit was designed was a low-cost black and white mains portable with a 12-inch screen (measured diagonally). Mains power is delivered to the set via a built-in isolating transformer. Initial safety checks were carried out to ensure that the plug and leads were correctly wired and that the chassis was grounded. In the absence of a circuit diagram for the set, it was decided to tap the video signal from the most obvious point – the cathode of the picture tube. Oscilloscope probings were made to establish which of the CRT (cathode ray tube) socket pins were the cathode and ground connections. At all times, proximity to the separate EHT (extra high tension) lead to the tube was avoided since it could be expected to be carrying a potential of several thousand volts. The oscilloscope probes were only connected when the TV was disconnected from the mains.

The signal feeding to the cathode pin contained the line and frame sync pulses and the video data. The 50Hz frame-sync pulse peaked at 120V and the 15.625kHz line sync pulse peaked at 100V, while video data swung between 50V and 70V (see Fig.3). Other readings revealed that the tube heater was powered by 12VDC, that the brightness-controlling pin voltage was variable between -25Vdc and +25Vdc, and that another pin carried the line sync pulses peaking at 300Vdc. All voltages were referenced to chassis ground.

Only connections to the cathode and ground pins were required and the circuit in Fig.4 shows how the signal voltages are attenuated and the sync and video data extracted. The resistor chain R9, R10 and VR3 is connected between the CRT cathode and ground. The component values were selected so that the peak maximum voltage of 120V at the cathode could be set by VR3 to less than 5V at the junction

of R9 and R10. Constructors should establish by calculation the optimum resistor chain values to suit their own TV signal level characteristics.

Precautions

In the interests of safety, the use of an opto-isolator between the TV and the unit would have been preferable and a for this circuit is shown in Fig.5. The isolator should have a bandwidth of at least 4MHz, preferably higher, and its LED resistor value must be calculated to suit the device and the cathode voltages. However, having satisfied myself concerning the safety aspects of my own TV set and of the environment within which the unit was to be used, the simpler resistive coupling of Fig.4 did the job. An advantage of using this method is that it imposes less of a load on the TV's cathode drive circuit (an opto-isolator requires around 10mA to drive its internal LED). With the prototype, a dedicated connection between the TV ground and unit ground was not used since both were already indirectly grounded via the earthed mains plugs.

It is stressed that readers must give full consideration to the safety of the intercoupling and grounding techniques they choose to use and of the way in which they are implemented. It is also recommended that TV CRT signal levels, polarities and contents should be determined before building the unit.

Sorting The Signals

In Fig.4, the tapped voltage from R9/R10 is buffered by TR1. VR1 is used to set the signal level fed to TR2, allowing adjustment of the amount of amplification given to the video portion of the signal. In the final setting-up, the level is adjusted so that the maximum output signal level is close to +5V while the line sync pulse portion drives the transistor into saturation. In the software there is a routine which looks out for the saturation (0V) portion of the swing, using it to determine the initial line sync point. The setting of this level is not particularly critical since the software routines can be modified to take care of line sync and amplitude deviations.

The only hardware sync extraction directly required is that of the 50Hz frame pulse. This is derived via the network from C8 to TR3. VR2 adjusts the signal so that the pulse is cleanly extracted, swinging TR3's output between +5V and 0V. The adjustment of this signal is a little more critical than that of the video as it controls the resetting of the unit's counters and thus of the primary reference point. Too much amplification could result in video data producing undesirable pulses.

Putting It All Together

Fig.6 and Fig. 9 show the printed circuit board track and component layouts. The PCB has been designed to plug straight into the expansion sockets of a PC. It may be treated

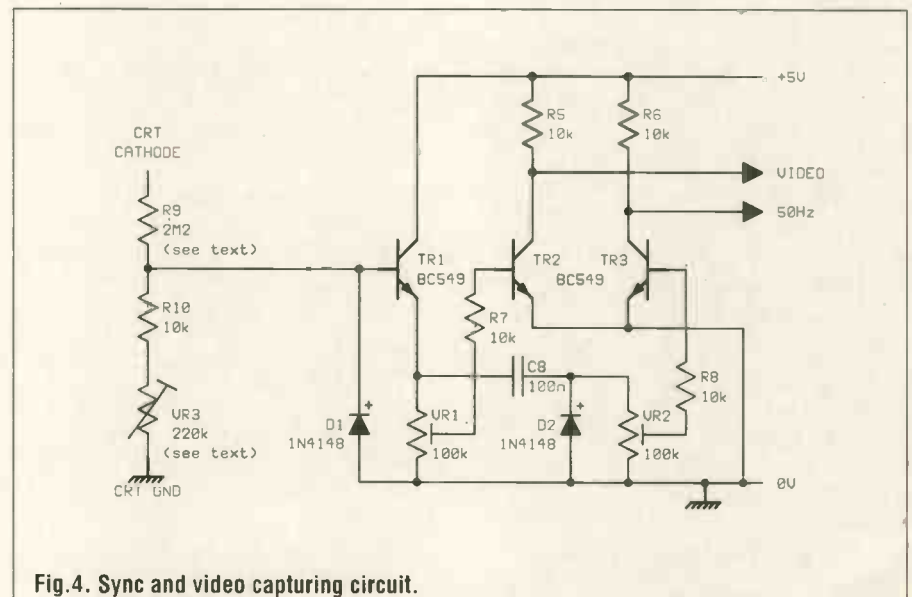

Fig. 4. Sync and video capturing circuit.

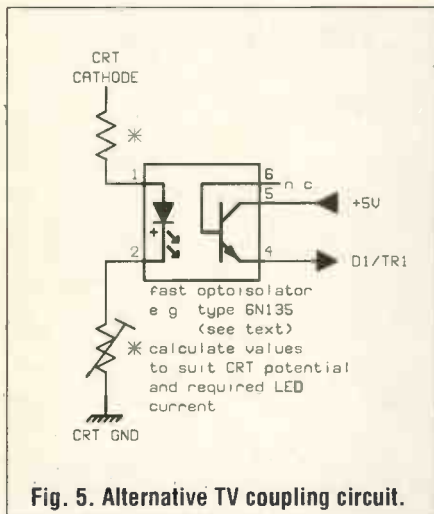

Fig. 5. Alternative TV coupling circuit.

either as a double or single sided board. If it is built as double-sided, the interconnections between upper and lower tracks should be made by inserting pins into the interconnecting holes, soldering them on both sides.

If only single sided board making facilities are available, the upper and lower sides may be treated as two separate boards. Each should be plugged into separate PC expansion sockets (these sockets are internally connected on PCs), observing the correct track polarities. In this instance, only the socket-connecting tracks of the second PCB are used, wiring them to their equivalent points on the main PCB. With the latter board, link wires must be made as shown in the drawing. If preferred, a length of Veroboard could be substituted for the second board since in this role it only serves as a plug.

Additional wiring points have been put onto the PCB allowing it to be connected to the computer via a 20-way cable harness terminated in a separate expansion interface plug. This enables constructors to test the assembled board outside the computer. On completion of testing, the wiring harness can be removed and the unit plugged directly into the expansion socket.

Programmable Pictures

The software was primarily written in GW-Basic, as shown in Fig.7. This dialect offers selection of three graphics colours at one time, plus a background default colour. (Regrettably, I could find no way in which the PC's colour registers could directly accessed via GW-Basic). However, Locomotive Basic 2 allows simultaneous selection of 16 colours. Perversely, though, the version used does not allow access to the expansion ports, preventing direct use of the Tele Snapper unit. The way round this is to first access the unit via GW-Basic, outputting the sampled data to disk. Locomotive Basic 2 can then be loaded together with the program in Fig.8 and the disk file inputted, allowing full manipulation of the data and colour display formats. Some remarkable display results can be achieved in this roundabout way.

The software listing in Fig.7 has been written as a simple framework which can be modified and added to as desired. It has three sections:

data capture, re-input for pictorial display with modification, and re-input for display as oscilloscope-type waveforms. (Experimenters will spot that this project can be used to display waveforms from signal sources other than TVs, so serving as a simple scope.)

Lines 10 and 20 in the listing set the background and text colour parameters, together with the graphics mode and frame area. For sampling the TV via the unit, line 30 remains as a REM statement, bringing in the disc file opening routine at line 50. In this line the file name within quotes should be changed as appropriate.

Line 60 cycles the unit through the first few TV data lines, ignoring them since they do not hold picture data. This loop may be contracted or extended as preferred. Line 70 looks for the zero-level line sync data, from which initial screen positioning is determined. This line may also be changed or omitted.

The main sampling routine starts at Line 80 in which a loop allowing for 199 TV screen lines to be input is set up. There are, in fact, 256 screen lines held by the unit's memory, all of which could be input, though only the first 198 will be displayed owing to screen limitations.

Line 90 sets the loop length required for one line. The figure of 256 is important since this represents the number of samples taken on each line as set by the unit's 4MHz sampling clock. As only six data lines, D0-D5, are used, the value input as variable E is ANDed with 63, thus knocking out bits 6 and 7. To reduce its byte size, the result is converted to an Ascii character and sent to disc. The data is also sent to the screen as a pixel of one of four colours, as determined by the result of dividing E by 16 in line 110. At the end of both loops the disk file is closed and the program stops.

By converting data to ASCII characters, the file size for one complete TV frame of 256 lines is approximately 200Kbytes. Obviously, there are several ways in which this quantity can be reduced. For example, the data could be compacted into much longer strings. It would also be possible to increase some bytes by different powers and OR them with other bytes, taking advantage of the

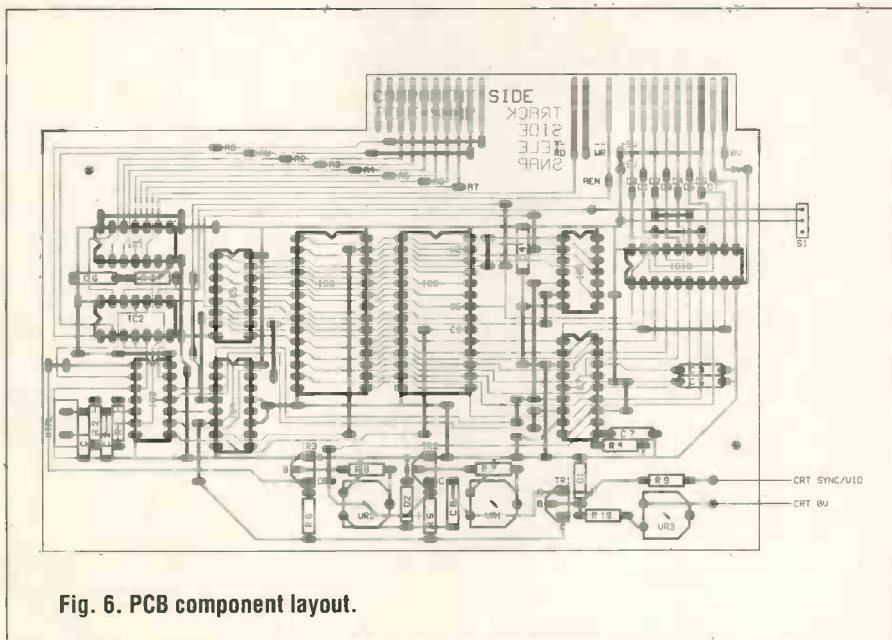

Fig. 6. PCB component layout.

```

100 CLOSE #3:CLS
110 OPEN #3 INPUT "STORE8"
120 E=5000
130 FOR D=5000 TO 0 STEP -
15
140 C=0:D1=D:A1=A
150 FOR A=1 TO 5120 STEP 20
160 INPUT #3,E$
170 E=ASC(E$)-64
180 P=INT(E/4)
190 IF P=F THEN 220
200 LINE A1;D1,A;D COLOUR F
210 A1=A:D1=D:F=P
220 NEXT A
230 LINE A1;D1,A;D COLOUR F
240 NEXT D
250 CLOSE #3

```

Fig. 8. Locomotive Basic screen plotter.

full 256 Ascii values. However, such compacting and subsequent decoding will result in speed penalties.

To re-input the data, line 30 should be amended to route the program to line 150. The file name in this line should be changed as required. In this example, the first 14 TV lines are input and ignored. From line 220 the main input loops are set up and the disc data is input as E\$ to be converted back to a numeral held as E. Between this point and the instruction to plot the pixel on screen, any amount of manipulation can be performed by inserting suitable conditional and corrective lines. The final answer is a colour attribute value, usually between 0 and 3, held as variable P and plotted on screen in line 260.

To make more space for the modifying statements, call RENUM to renumber the program lines. Additional program lines may be inserted to write the modified data to another disc file. Selected sections of pictures can be extracted in this way, allowing for picture line length shortening as well, provided that subsequent input routines are amended accordingly. Data may also be stored as graphics symbols, selecting specific areas as detailed in the GW-Basic manual.

To display data as a scope-type waveform amend line 30 to route the program to section three at Line 300. This routine is of particular benefit when first setting-up the presets on the PCB. It can also give guidance when writing display modifying instructions.

Fig.8 shows an example of a disc file input and plotting routine as written for Locomotive Basic 2, allowing a choice of 16 colours. ■

```

10 SCREEN 0:COLOR 4,5:SCREEN 1:COLOR 0,1:KEY OFF
20 VIEW (1,1)-(258,198),0,3
30 REM GOTO 150
40 REM TRANSFER FROM MEMORY CARD TO DISC ROUTINE
50 OPEN "STORE8" FOR OUTPUT AS #1
60 FOR F=1 TO 8*256:E=INP(768):NEXT
65 REM 768 IS DECIMAL OF HEX $0300
70 FOR F=1 TO 256:E=INP(768) AND 63:IF E>0 THEN NEXT
80 FOR F=1 TO 199
90 FOR A=1 TO 256:E=INP(768) AND 63
100 PRINT #1,CHR$(E+64)
110 PSET (A,F),E/16
120 NEXT:NEXT:CLOSE #1
130 STOP
140 REM DISC RE-INPUT AND DISPLAY ROUTINE
150 OPEN "STORE8" FOR INPUT AS #1
160 LOCATE 2,2:PRINT "WAIT!"
170 FOR A=1 TO 14*256:INPUT #1,E$:NEXT
180 LOCATE 2,2:PRINT " "
190 LOCATE 2,34:PRINT "BLU 1"
200 LOCATE 3,34:PRINT "RED 2"
210 LOCATE 4,34:PRINT "WHT 3"
220 FOR F=1 TO 199
230 FOR A=1 TO 256
240 INPUT #1,E$:E=ASC(E$)-64
250 P=INT(E/16)
260 PSET (A,F),P
270 NEXT:NEXT:CLOSE #1
280 STOP
290 REM SCOPE-TYPE DISPLAY ROUTINE
300 OPEN "STORE8" FOR INPUT AS #1
310 FOR G=1 TO 10:F=1:D=0:CLS
320 FOR A=1 TO 8:FOR B=1 TO 256
330 INPUT #1,E$:E=ASC(E$)-64
340 LINE (B,D+C)-(B,D+E),F:C=E
350 NEXT:F=F+1:IF F>3 THEN F=1
360 D=D+20:NEXT:NEXT

```

Fig. 7. GW-Basic listing

Components

Resistors

R1 10M
R2 2k2
R3, R5-R8, R10 10k
R4 100R
R9 2M2 (see text)
All 0.25W 5% carbon or better

Potentiometers

VR1, VR2 100k min horiz preset
VR3 220k min horiz preset
(see text)

Capacitors

C1, C2 68p polystyrene
C3-C7 100n polyester

Semiconductors

D1, D2 1N4148
TR1-TR3 BC549
IC1 74HC4078
IC2 74HC11
IC3 74HC04

IC4 74HC157
IC5 74HC4040
IC6 74HC4024
IC7 CA3306
IC8, IC9 μ PD43256C
IC10 74HC541

DIL IC Sockets

14-pin (4 off), 16-pin (2 off), 18-pin, 20-pin, 28-pin (2 off)

Miscellaneous

S1 SPST min toggle switch

XTAL 4MHz crystal

Printed circuit board

Constructors note

The author's semiconductors were all purchased from RS/Electromail.

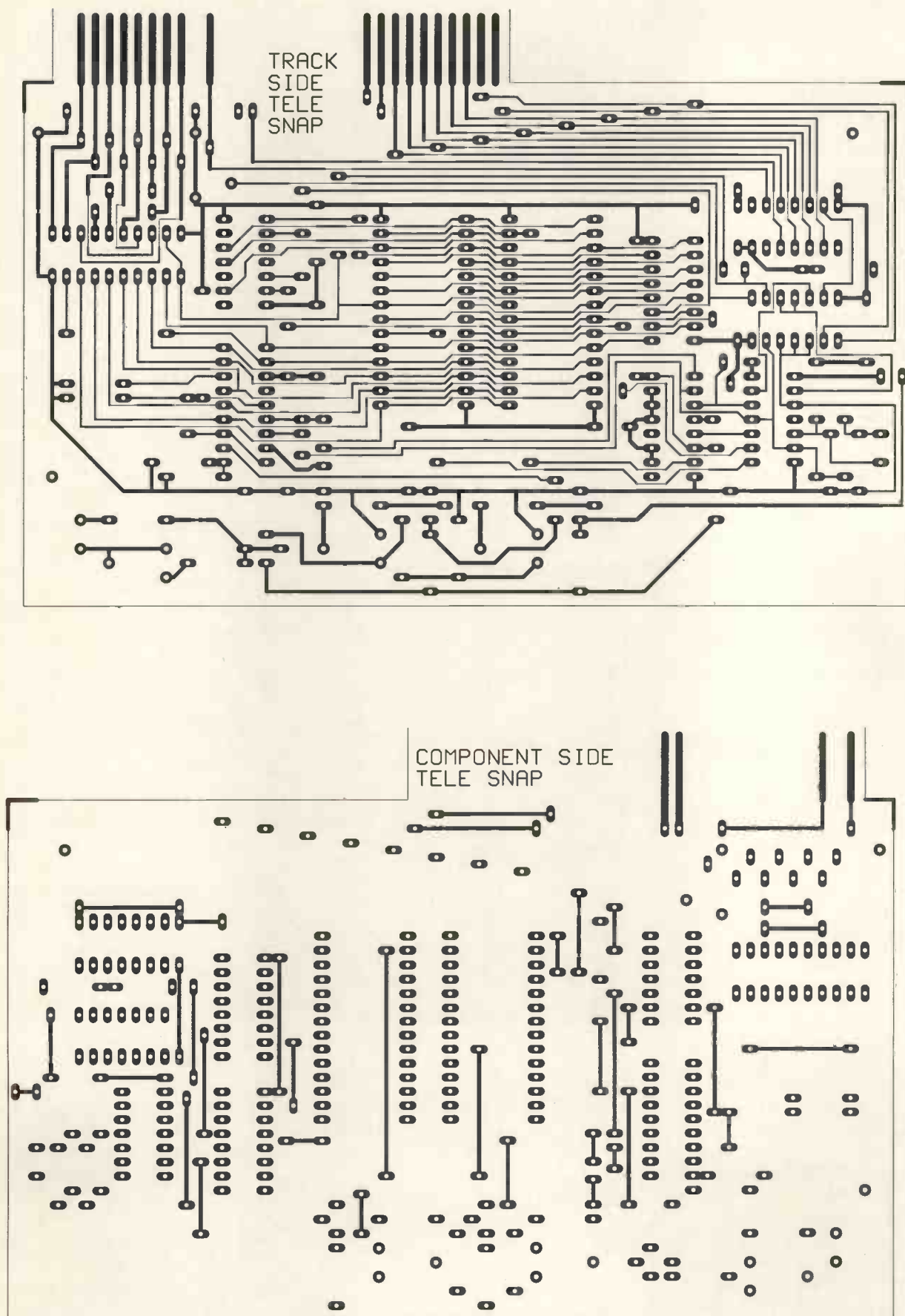

Fig. 9. The PCB track layouts.

JUST A SMALL SELECTION FROM OUR RANGE OF OVER 120 KITS

KIT NO	DESCRIPTION	PRICE £(EA)
1001	0.2 WATT FM TRANSMITTER	4.16
1004	LIGHT SWITCH	5.83
1006	800 WATT MUSIC-TO-LIGHT	4.99
1009	1 WATT FM TRANSMITTER	5.42
1011	MOTORBIKE ALARM	8.33
1013	AM-FM-VHF RECEIVER	13.33
1014	3x700 WATT WIRELESS MUSIC-TO-LIGHT	10.82
1018	GUITAR TREMELO	7.08
1020	0-5 MINUTE TIMER	5.42
1022	METAL DETECTOR	4.16
1026	RUNNING LIGHTS	8.33
1029	4 SOUNDS ELECTRONICS SIREN	4.99
1030	LIGHT DIMMER	4.59
1034	CAR BATTERY CHECKER	2.92
1036	TRANSISTOR TESTER	3.75
1037	DISCO STROBE LIGHT	11.25
1038	AM-FM AERIAL AMPLIFIER	2.92
1044	GRAPHIC EQUALIZER	12.91
1045	SOUND EFFECT GENERATOR	6.66
1047	SOUND SWITCH	9.58
1049	ULTRASONIC RADAR	14.98
1055	FM RECEIVER USING TDA7000	12.49
1059	TELEPHONE AMPLIFIER	8.33
1065	INVERTER 12V D.C. TO 220V A.C.	20.82
1069	12V D.C. FLUORESCENT TUBE UNIT	5.42
1073	VOX	6.24
1074	DRILL SPEED CONTROLLER	4.99
1075	ELECTRONIC DICE WITH L.E.D.s	6.66
1084	TV LINE AMPLIFIER	3.34
1091	GUITAR PRE-AMPLIFIER	7.50
1098	DIGITAL THERMOMETER WITH LCD DISPLAY	20.82
1111	LOGIC PROBE	3.75
1114	ELECTRONIC LOCK	7.50
1117	TV PATTERN GENERATOR	9.17
1119	TELEPHONE LINE RECORDING	4.16
1122	TELEPHONE CALL RELAY	6.66
1124	ELECTRONIC BELL	4.99
1125	TELEPHONE LOCK	6.66
1129	NEGATIVE ION GENERATOR	14.16
1130	TELEPHONE "BUG" DETECTOR	3.34
1133	STEREO SOUND-TO-LIGHT	9.52
1203	MINI FM TRANSMITTER WITH MIC. (SUPPLIED READY ASSEMBLED)	4.16

All kits contain a Silk-Screened high quality p.c.b., components, solder, wire and FULL instruction sheet.

Plastic boxes with silk screened front panels are available for some of the kits. Full details are given in our catalogue.

SPECIAL OFFER

QIC BACK 60MEG TAPE STREAMER
QIC 60 FORMAT - INTERNAL FITTING
5.25" TRAY - ALL PARTS SUPPLIED
EXCEPT DC600 CARTRIDGE
CAN BE USED ON XT, AT & PS2

PRICE : £184.00

3.5" EXTERNAL FLOPPY DISC DRIVE BY WELL KNOWN
MANUFACTURER 1 MEG (720K FORMATTED)
GREY - COMPLETE WITH CASE

PRICE : £36.00

FLOPPY DISC DRIVES

Internal	£	Amstrad	£
5.25" 360K	37.00	FD1 3" 664/6128	79.95
5.25" 1.2M	40.00	FD6 3.5" 2086	85.00
3.5" 720K	39.00	FD7 3.5" 2286	85.00
3.5" 1.44M	42.00	FD9 3.5" PC2000	95.00
External		FD11 5.25" PC2000	95.00
5.25" 360K	45.00	SD1 3.5" PC200	95.00
5.25" 1.2M	48.00	SD2 5.25" PC200	95.00

ALL DRIVES BY WELL KNOWN MANUFACTURERS

Twin 360K 5.25" Floppy Disc Drive complete with Power Supply. Enclosed in a professional white case complete with mains lead. Connections are via a 37 Pin "D" Socket. Full connection details supplied.

TWIN FDD + PSU£68.95

GENDER CHANGERS

STANDARD	
25 way male-female	£3.50
25 way female-female	£3.50
MINI VERSION	
9 way male-male	£2.95
9 way female-female	£2.95
25 way male-male	£3.50
25 way female-female	£3.50

CABLES, LEADS & MISCELLANEOUS (* LEADS ARE 2 METRES LONG)

RS232 male to male	*£5.00
RS232 male to female	*£5.00
Centronics to Centronics	*£27.00
FDD Power Splitter (standard)	£4.00
Power Extension Cable (M/B)	£6.00
FDD IDC Pin to Edge Conn PCB	£4.00
Power Lead for 3.5" Floppy	£3.00
Keyboard Extension Lead	*£5.50
Monitor Extension Lead	*£5.50
5.25" Tray for 3.5" Floppy	£5.50

These are just examples from our comprehensive stocks of computer items. Please contact our sales office if the item you require is not shown

★ ALL PRICES INCLUDE VAT ★

UK Orders:
Add £2.00 carriage

Europe & Eire:
Deduct 15% VAT
(divide price by 1.15)
Add £5.00 carriage

Outside Europe
Deduct 15% VAT
(divide price by 1.15)
Add £10.00 carriage

Hobbykit Ltd.

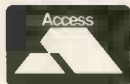

CREDIT CARD HOTLINE
 081-205 7485



**UNIT 19
CAPITOL INDUSTRIAL PARK
CAPITOL WAY
LONDON NW9 0EQ
FAX NO: 081-205 0603**

For a comprehensive guide covering our Computer products, Kits, Test Equipment and Tools please send an A4 envelope stamped as follows:

UK:
£0.45
Europe & Eire:
£1.00
Outside Europe:
£2.75

The Transistor Story

Ian Poole's latest history lesson takes in at that multi-purpose electronic component, the transistor.

Transistor technology is the corner stone of modern electronics. Without semiconductors the world would be a totally different place. Everything from domestic goods like video recorders to the highest technology commercial and military equipment depends on semiconductors and their associated circuitry. It is quite a staggering thought that when the first people started to investigate some of the effects which were to lead to the development of the transistor, there were few resources made available because valves and thermionic technology seemed to be the way of the future.

Early Days

Some of the first semiconductor effects to be used were in early radio receivers. At this time the most insensitive part of the radio

was the detector. Accordingly many people were investigating new methods of converting the RF (radio frequency) signals to audio frequencies. Early ideas like the coherer, a glass tube containing iron filings which were made to stick together and complete an electrical circuit which in turn made a bell ring, were unsatisfactory. A solution was found when Ambrose Fleming of University College London invented the thermionic diode valve. This was a great improvement over anything else but was not the complete answer and had several drawbacks. It required a battery supply to energise the heaters that produced the electrons and was expensive to make.

Other organisations like the de Forest Company in the USA were investigating ideas, taking care not to infringe Fleming's patents. The

1906	The Cat's Whisker is invented.
1926	Schrodinger's Equation is formulated.
1940	OHL demonstrates the rectifying properties of a PN junction.
1945	Bardeen, Brattain, and Shockley come together as a team to work on semiconductors.
1947	On 16th December the first transistor works.
1954	The first production transistor is announced by Teal.

first was the triode valve which was used purely as a rectifier. The other was a semiconductor device, the crystal detector which soon became known as the 'Cats Whisker'. Essentially it consisted of a crystal of galena (lead sulphide) with a small piece of wire touching it. Unfortunately, it was notoriously unreliable, as the position of the whisker to be changed quite frequently, and it was very inefficient. Even so it gained wide spread use until the early 1920's because it was cheap and easy to make.

In view of its advantages people used the basic idea as a starting point for new devices. But since the method of operation was not understood, it proved rather difficult – the main improvement was to use silicon crystal instead.

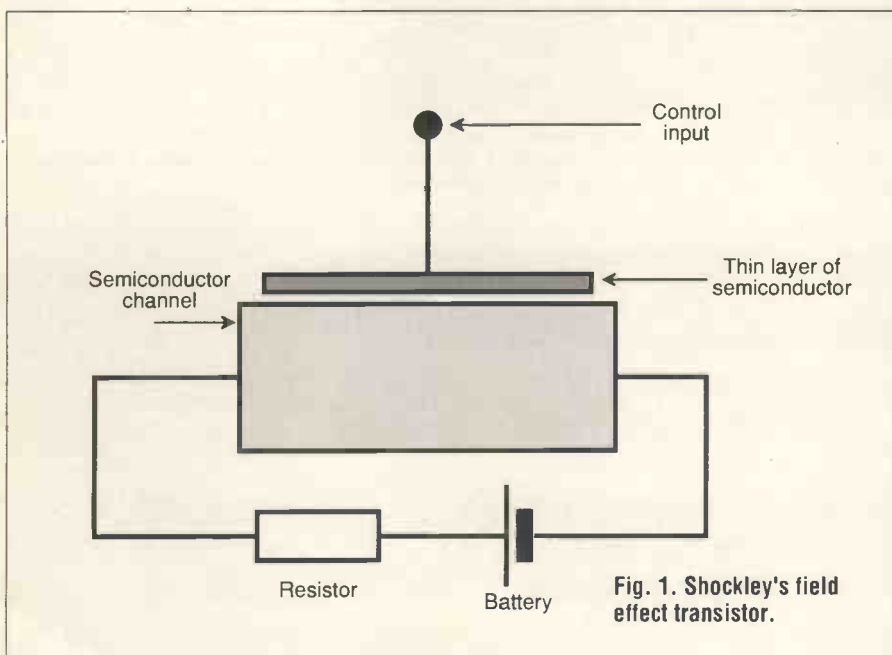

Fig. 1. Shockley's field effect transistor.

The Transistor Team

John Bardeen was born in Wisconsin on 23rd May 1908. His academic career started at the University of Wisconsin after which he went to Princeton for his PhD. After a fellowship at Harvard he took up a teaching post at Minnesota University. Finally he joined the solid state group at Bell Laboratories in the Autumn of 1945. In 1956 with Shockley and Brattain he received a Nobel Prize for his work on the transistor. However, by this time he was working on superconductivity. In fact it was this work that he considered his greatest achievement and in 1972 he was awarded a second Nobel Prize. He received a number of other notable awards including a gold medal from the Soviet Academy of Sciences. He died at the beginning of February 1991 aged 82.

Walter Brattain was born in China in 1902. Shortly after his birth his parents returned to the USA and he grew up in Washington State. He took his first degree at Whitman College in Washington State and in 1929 he moved to the University of Minnesota for his PhD. After leaving university Brattain attempted to enter Bell Laboratories but he failed and joined the National Bureau of Standards. However on a second attempt he managed to enter Bell where he was quickly employed in work on copper oxide semiconductor rectifiers. He remained at Bell until his retirement in 1967 at which time he took up the post of visiting professor at Whitman College until his death at the age of 85.

William Shockley was born in London on 13th February 1910 of American parents. He remained in England until he was three and then the family returned to the USA he obtained his first degree at the California Institute of Technology and then he moved on to the Massachusetts Institute of Technology for his PhD in 1936. After leaving university he joined Bell Laboratories to work on electron diffraction. In 1955 he set up his own company called Shockley Semiconductors in his home town of Palo Alto. Later the company name was changed to Shockley Transistor, but it had to close in 1969. In 1963 Shockley also became a professor at Stanford University.

Theoretical Work

In the early days of wireless thermionic valve technology was used almost exclusively. This meant that the majority of research work was in this area rather than with other possibilities. After all, small improvements in valves could reap large rewards, and as they were still comparatively young they could be improved quite easily.

In spite of this, academic research was beginning to be applied to some of the fundamental laws of physics. The first breakthrough came in 1926 when Schrodinger developed an equation which described the behaviour of the electron. A year later Heisenberg developed a theory known as the Uncertainty Principle. Other eminent scientists soon joined the ranks and Bloch started to develop his band theory and Peierls devised the concept of holes in a crystal lattice.

The Climate Changes

The advent of the Second World War gave a boost to research in electronics. One of the early successes of the British war effort had been the deployment of radar and the need arose for further developments in the area of microwave diodes with very low values of capacitance. Existing valve diodes were not well suited to high frequencies because of their

physical size – the alternative was to turn to semiconductors.

Experts from the UK and USA in all the fields associated with diode technology were brought together. Very quickly work started on producing point contact diodes – a development of the cat's whisker. Another result was the doping of silicon with trace elements to produce N-type and P-type materials.

More Discoveries

Of all of the developers, Bell Laboratories was quickest to see the possibilities associated with semiconductors. In order to improve progress a number of specialist teams were set working on slightly different fields of semiconductor research. The most famous of these teams consisted of

Bardeen, Brattain, and Shockley who started to work towards an idea Shockley formulated about a field effect semiconductor triode.

Shockley had worked through a number of calculations and he thought that the resistance of a section of semiconductor could be changed by applying a charge to an electrode close to it but physically insulated from it. Accordingly he constructed a device like that shown in Fig. 1. To his surprise and consternation it didn't work. He called in Bardeen who suggested that electrons were being trapped in the uneven surface and shielding the channel of the device from the external field.

Unfortunately they could not think of a way round the problem until a chemist named Gibrey suggested immersing the device in an electrolyte. This idea gave a

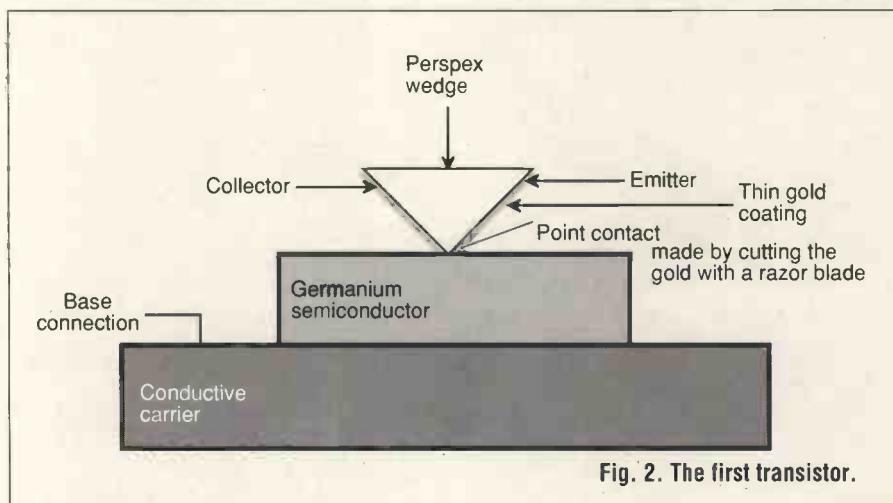
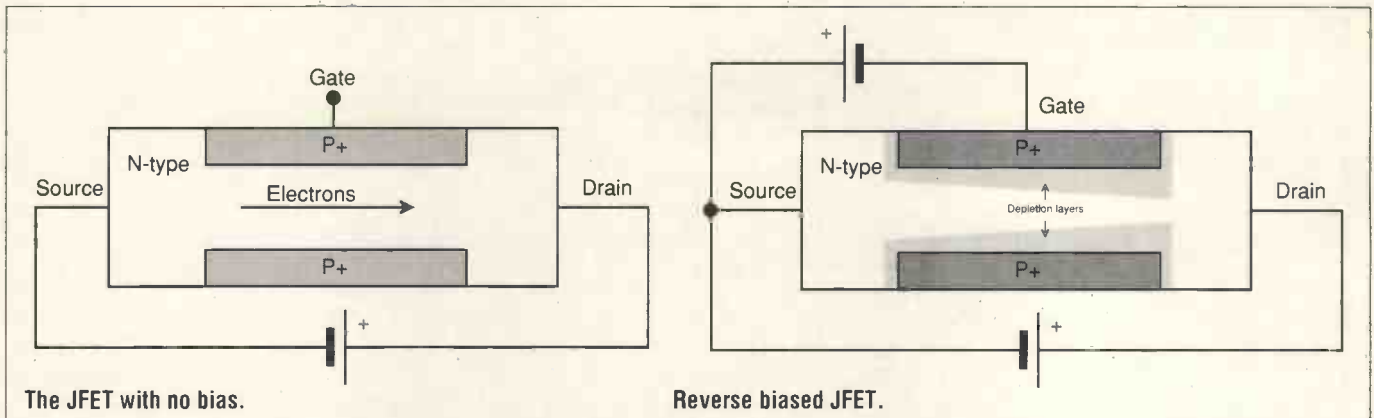

Fig. 2. The first transistor.



The JFET with no bias.

Reverse biased JFET.

Operation of a JFET

As with all transistors, junction FET's have three contacts, the gate, drain and source. The second two form a channel along which electrons can flow when a voltage is applied across them. The amount of current that flows is governed by the conductivity of the channel and the drain source voltage. Putting a voltage between the gate and

the source with the gate connected to negative and the source to positive reverse biases the transistor. In this condition, the number of charge carriers in the areas around the gate decrease and form a depletion layer which has a higher resistance than the normal channel. Increasing the amount of reverse bias voltage increases the

amount of depletion and hence increases the resistance of the channel. The conductivity or resistance of the channel can therefore be controlled by the voltage between the gate and the source – this is the basic requirement for an amplifier.

certain amount of success and some amplification was obtained but only at low frequencies.

In order to overcome this problem further ideas were investigated which entailed evaporating a gold spot onto the channel of the device. This proved to be quite effective and they found that the conductivity could be altered by changing the bias. However they also noticed that when a point contact was placed near the gold spot this third

electrode gave some gain. This was a great surprise to the team who in trying to invent a field effect device had stumbled across the transistor.

Once the initial effect had been noticed they made further improvements very quickly. They soon worked out that two point contacts placed very close together would give a better effect. To do this some gold was evaporated onto a wedge of perspex and the tip cut with a razor blade. This point was then placed onto some germanium

semiconductor. The experiment was carried out on 16th December 1947 and it worked first time, giving a transistor with a reasonable amount of gain. Seven days later they demonstrated the transistor to some top executives in Bell but nothing was released to the press for six months so that further work could be carried out.

PN junctions

The junctions in transistors depend on two types of material, N type and P type. The first is made from silicon which is doped with a very small amount of impurity such as arsenic, antimony or phosphorous. This causes extra electrons to be donated or made available for conduction in the normally non-conducting crystal lattice – hence the term N or negative type. P type material is silicon doped with aluminium, indium or boron which has accept electrons from the normal lattice leaving holes which effectively conduct positive charge – hence P or positive type. Joining the two types together forms a PN junction with some of the holes migrating to the N type and some of the electrons to the P type. Because the loss of electrons and holes causes potentials to build up in

the different materials, only a limited amount of transfer can take place before the resulting potential repels any more movement – the P type acquires a negative charge due to incoming electrons replacing the holes and the N type a positive charge due to additional holes being formed from lack of electrons. Connecting a battery across the junction with the positive terminal to the N type (reverse bias) material increases the normal junction potentials so nothing moves across and a layer of non-conduction or depletion forms. Placing the battery the other way around (positive terminal to the P type or forward bias) overcomes the internal potentials and a current flows through the circuit – the basic operation of a diode.

Manufacturing

The transistor in its first form was very crude, inefficient and difficult to manufacture with any degree of reliability. The next stage in its development was to improve it so that it could be made cheaply and in large quantities.

In 1949, Shockley was the first to come up the idea of replacing the point contacts with P-N junctions created by doping the semiconductor. Whilst his ideas were perfectly sound in theory he was not able to implement them, except in the laboratory, because the technology of the time was not sufficiently advanced.

A little later a man named Teal, who was working on growing single crystals of semiconductors, managed to dope specific areas and make multiple junctions. However it was not until 1954 that the first production devices were available. They were produced by an almost

unknown company in America called Texas Instruments.

It did not take long before other companies started producing their own transistors, and as the 1950s progressed more became available. Even so they remained expensive and by the end of the decade a typical audio transistor would cost about £1.50 or thirty shillings in the money of the day.

Fortunately in the 1960s production techniques were improved and silicon became more widely used causing the price of transistors to fall dramatically. ■

The IGFET

The insulated gate field effect transistor or IGFET uses electrostatic forces in a different way to the normal field effect transistor. The source and drain regions are made from heavily doped N type material (N+) implanted in a P type substrate. The gate made by placing a layer of insulation, usually silicon dioxide followed by a layer of aluminium as shown in the top diagram. The PN junctions around the source and drain form depletion layers and prevent current flow through the device (i). By applying a small voltage across the source and gate, the holes in the substrate are repelled allowing the depletion layer to stretch from the source to the drain (ii). Raising the voltage further causes electrons from the source to move into the region beneath the gate which forms a layer of electrons between the source and the drain, known as the inversion layer (iii). A voltage applied across the drain and source will now cause a current to flow, the size of which depends on the conductivity of the channel and the drain to source voltage. When voltage flows through the channel, the voltage at the drain is less than that at the source and the depletion layer thickness increases at the drain (iv). As the voltage across the channel increases the depletion layer thickness increases further and makes the inversion layer thinner and eventually pinches it off (v). Any more increases in voltage simply cause the pinch point to move towards the source (vi). The drain current continues despite the loss of the inversion layer because electrons are swept through the depletion layer by the high voltage across the source and drain.

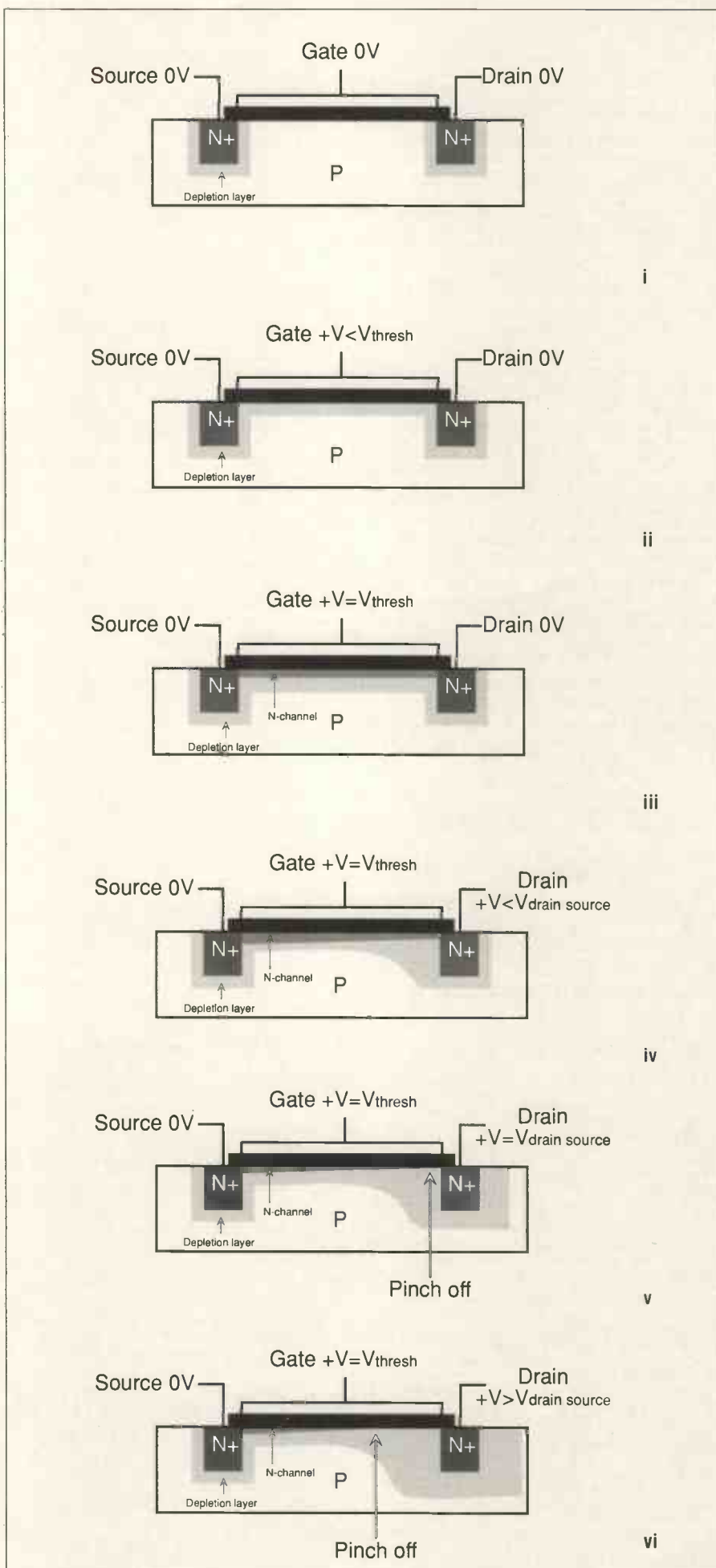

We Have The Power

Dual power supplies are essential when building and designing electronic circuits. Unfortunately they are expensive and difficult to build, Owen Bishop has a solution...

Operational amplifiers are used in many circuits and, more often than not, they require a dual power supply. Usually this must be in the range $\pm 5V$ to $\pm 12V$ and to provide such a supply during the design, building and testing stages of a project is not always easy. A commercially-built dual supply is invariably expensive because it is likely to have many refinements that are not strictly essential for the average user. Batteries are suitable but expensive, and you need a lot for a dual supply. A drawback is that those on the positive side of the circuit tend to go flat more quickly, making the supply unbalanced. The only solution is to build a dual PSU, but here the beginner runs into the problems of working with mains voltages and ensuring that the finished product is totally safe.

Pre-fab PSU

This project gets around the difficulties of wiring up the mains sections of the circuit by using the cheap mains adaptors or battery eliminators that are usually housed in an extra-large plug-top which fits directly into a mains socket. A light lead, usually ending in a multiple plug, provides a rectified (DC) current at a low voltage. Many of these adaptors have a switchable outputs of 3V, 4.5V, 6V, 7.5V, 9V and 12V. The economics of large-scale production are such that these units sell for considerably less than it would cost to buy the equivalent transformer, rectifying and smoothing components, enclosure, and mains plug.

Unfortunately, the cheapest of these adaptors have two big

disadvantages. Their output voltage is unregulated and is seldom near the nominal value. The unregulated curve of Fig. 1 shows how the output voltage, nominally 9V, varies with the current being drawn from the unit. These figures were obtained from one of the adaptors eventually used in this project. For currents up to about 70mA, the output voltage is over 11V. It is less than 9V for currents in excess of 550mA. Thus if the powered circuit is switching LEDs, relays, lamps, loudspeakers or other devices that require appreciable current, the supply voltage changes wildly with variations in current demand. This can lead to all kinds of feed-back effects, even putting the circuit into continuous oscillation. The situation is particularly serious with op-amp circuits because very often the positive supply is called upon to provide more current than the negative supply. Inevitably this

unbalances the power lines and upsets the working of the amplifier circuits.

The other disadvantage of the cheapest units is that they are not protected against overloading. A few moments of excessive current and the winding of the transformer burns out.

This project uses a pair of adaptors to provide the basic DC power and follows them with regulator circuits to provide a constant output voltage and current-limiting. The regulator circuits are continuously adjustable from $\pm 5.6V$ to $\pm 12V$. If used as a single supply, the unit can provide from 5.6V to 24V DC. The maximum current obtainable depends on the rating of the adaptors used. The regulated curve of Fig.1 shows the output voltage against current with the adaptor switched to its nominal 12V range and the regulator circuit adjusted to

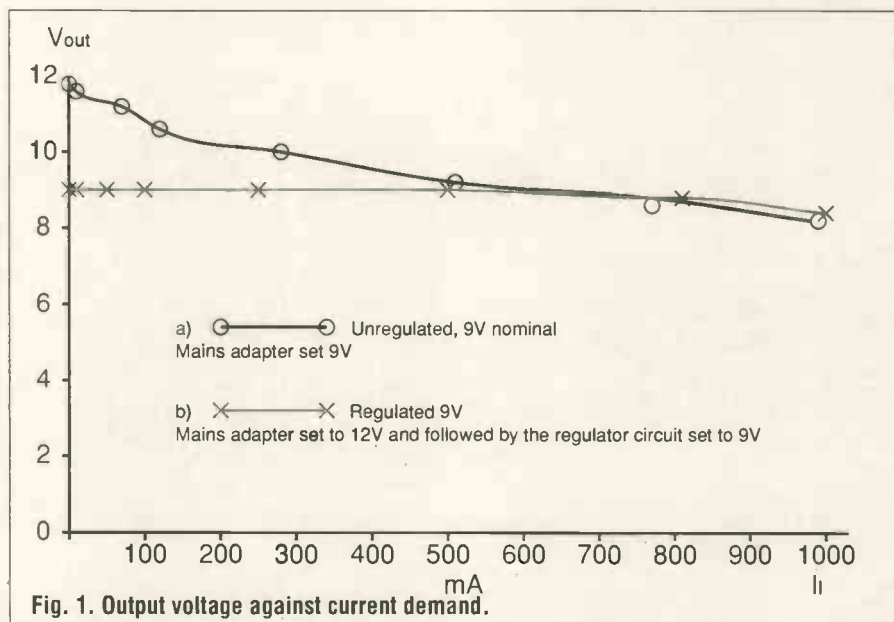

Fig. 1. Output voltage against current demand.

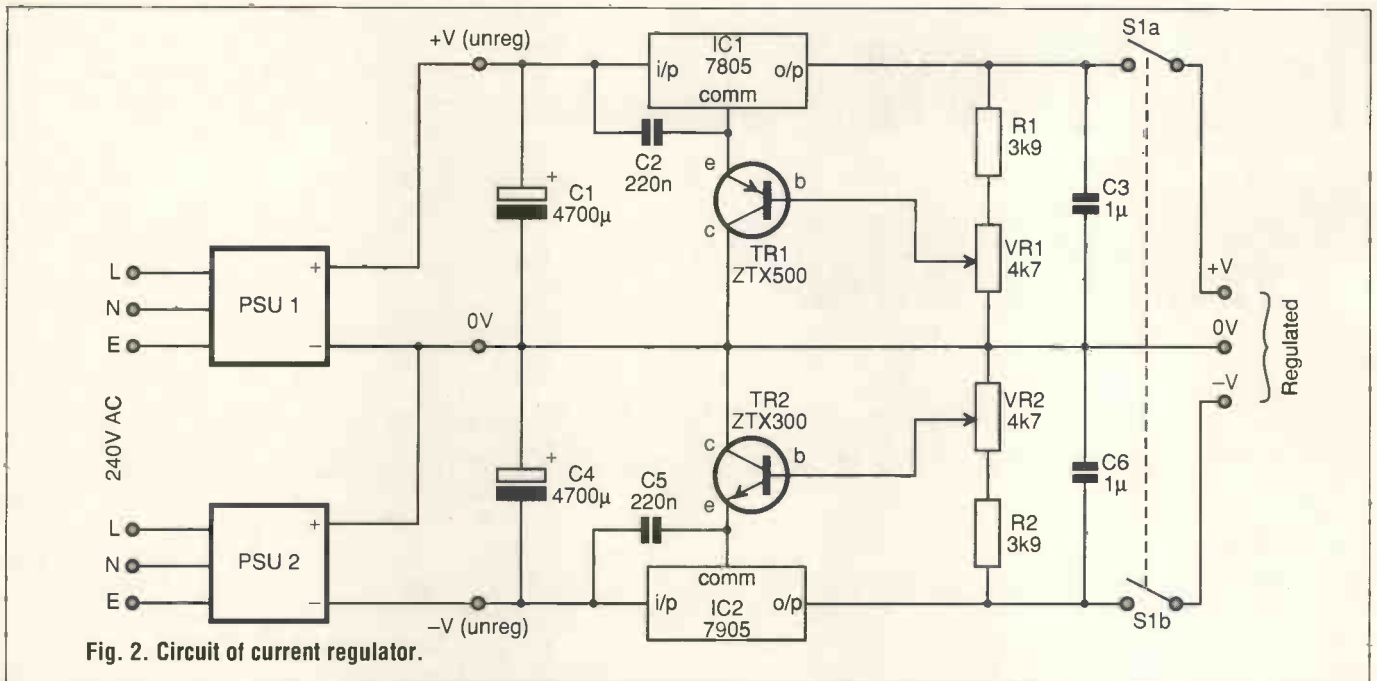

Fig. 2. Circuit of current regulator.

9V. Output remains within 0.1V of 9V for current up to 800mA, falling only to 8.4V at 1A, the maximum power delivery of the adaptor.

The positive half of this project can also be built on its own to improve the output characteristics of a single mains adaptor.

Regulation In Operation

Fig. 2 shows how two identical adaptors are wired together to give a +V/0V/-V output. The common 0V line passes through the circuit to the regulated output side. Taking the positive supply first, we have a large-value capacitor C1 to provide additional smoothing. Adaptors are often poorly smoothed, presumably because a capacitor of suitable size would add to the size and cost of

the unit. Next comes a three-terminal regulator IC wired so as to produce an output higher than that for which it is designed. IC1 is the familiar 7805 regulator, with an output of +5V. Its common terminal is connected to the emitter of TR1 instead of to the 0V line.

Since the output voltage of the regulator is constant at 5V above the voltage at its common terminal, the voltage at the wiper of VR1 is also constant. There is also a fixed voltage drop of 0.6V between the base and emitter of TR1. Consequently, the output voltage remains constant at a value equal to 5V plus 0.6V plus the voltage at the wiper of VR1. By varying the setting of VR1 we adjust the output voltage. The range extends from

5.6V up to about 2.5V less than the input voltage. The 2.5V is the headroom required to enable the regulator to function as such. The output from the regulator is stabilised by C3 and then goes to a switch.

The negative supply is the mirror image of the positive supply. It uses a 7905 negative voltage regulator. TR1 is of the NPN type, in contrast to the PNP transistor used on the positive side.

Getting It Together

The first step is to decide on the model of adaptor to be used. Unless you are building only the single supply, you need a pair of such units. It is essential that the output side of the adaptors is floating that

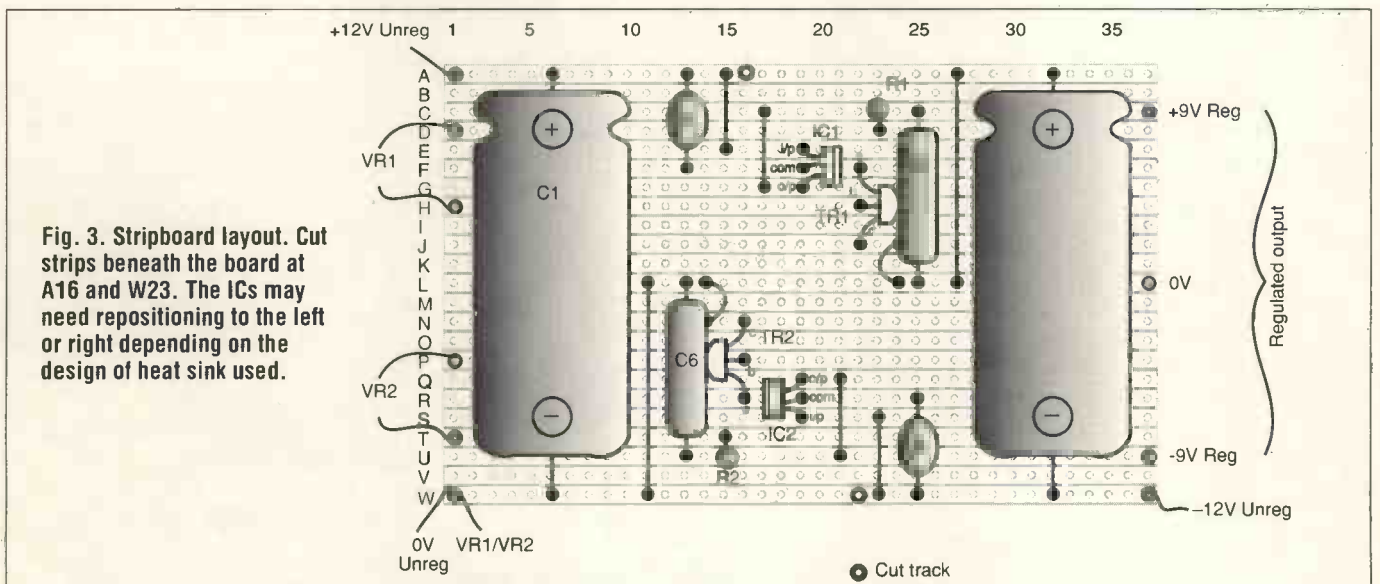

Fig. 3. Stripboard layout. Cut strips beneath the board at A16 and W23. The ICs may need repositioning to the left or right depending on the design of heat sink used.

is, the 0V terminal is not wired to mains Earth. In all the adaptors tried, the output is fully floating, but can be checked by measuring the voltage between the 0V terminal of one adaptor and the +V terminal of the other, when both are plugged in - this should give a zero reading.

The final design used a pair of adaptors switchable to 3V, 4.5V, 6V, 9V and 12V (all unregulated) with a maximum current rating of 1A each. They actually had current-limiting built in, but this is not essential as the regulators provide for it as well. Some adaptors are rated at only 800mA and, although the regulators will not allow more than 1A to flow, there is a possibility that prolonged excess current in the range 800mA to 1A may eventually burn out the adaptor. As a safeguard, 800mA fuses should be wired in the positive and negative lines. The smallest adaptors deliver only 300mA, so a 250mA fuse should be used for protection, and possibly a regulator of lower rating, such as 500mA.

The strip-board layout (Fig.3) has a certain amount of symmetry, but note that the terminal connections of the regulators are NOT identical (Fig. 5). Also C1 and C4 are not oppositely orientated. When the wiring is complete, the clip-on heat sinks should be fitted to each regulator. The strip-board is mounted in a plastic box and the potentiometers and switch are mounted on one side of it. The pots are wired (Fig.4) so that turning the left-hand one (VR2) anticlockwise reduces the negative output from -

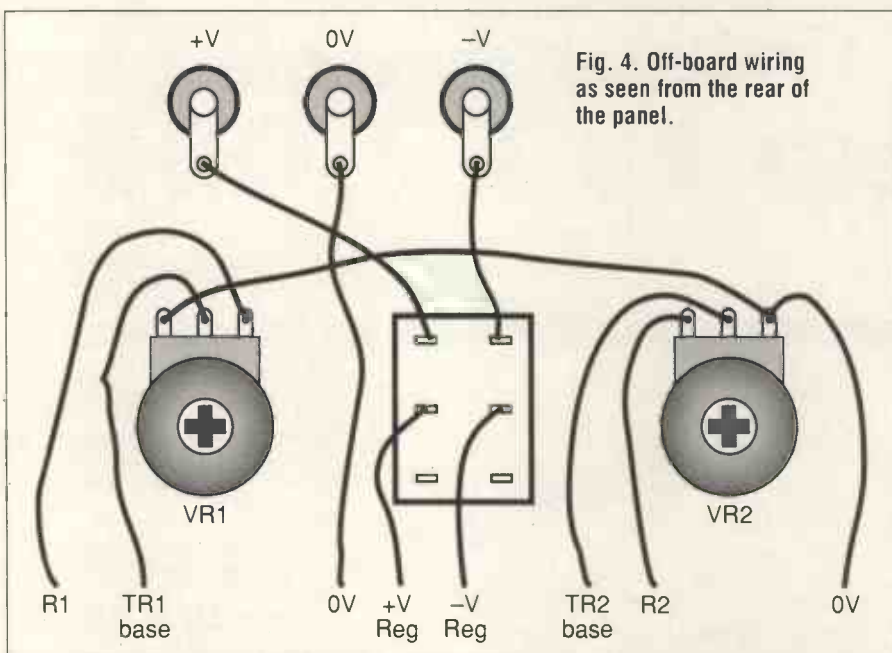
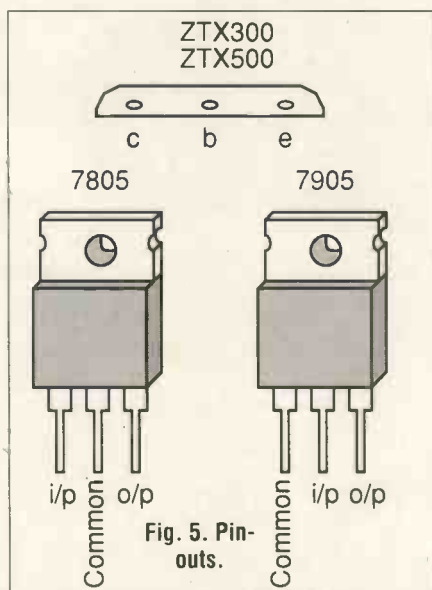

Fig. 4. Off-board wiring as seen from the rear of the panel.

5.6V to -9V (or less). Turning the right-hand knob (VR1) clockwise increases the positive output from +5.6V to +9V (or more).

The adaptors may be connected to the board either directly or by means of a pair of plugs mounted on the enclosure. The output from the circuit goes to three terminal posts which allow for connections to external circuits either by 4mm plugs, spade terminal or bare-ended wires. It is suggested that the terminal posts be red (+V), white (0OV) and black (-V).

Setting Up

Normally the adaptors are switched to their +12V range and the controls adjusted to give the required outputs in the range +5.6V to +9V. The +5.6V setting is higher than that normally recommended for 74 and 74LS logic ICs. However, most seem to operate normally at voltages up to +6V. There is no problem with the 4000 series of CMOS and the 74HC and 74AC series as these are rated to +15V. If it is essential to produce exactly +5V from this project, fit an additional 2-pole switch to connect the common terminals of each regulator to the 0V line. This grounds the emitters of the transistors, putting them temporarily out of action.

If only small currents are being drawn, it is preferable to switch the adaptors to +9V, making use of the fact that the excess voltage at currents up to about 50mA (Fig.1)

provides sufficient headroom. This minimises heating of the ICs. For currents up to 100mA it is also possible to obtain regulated voltages up to +12V by switching the adaptors to +12V and making use of the excess voltage to give headroom. ■

Components

Resistors

R1, R2 3k9, 0.25W, 5%
VR1, VR2 4k7 carbon potentiometer

Capacitors

C1, C4 4700µF, electrolytic, 25V working
C2, C5 220nF polyester
C3, C6 1µF polyester

Semiconductors

TR1 ZTX500 PNP transistor
TR2 ZTX300 NPN transistor

Integrated circuits

IC1 µA7805UC 5V regulator
IC2 µA7905UC -5V regulator

Miscellaneous

PSU1, PSU2 mains adaptors, unregulated, 9V/12V (see text)
S1 double-pole-double throw rocker or toggle switch
stripboard approx 24 strips x 37 holes (e.g. cut from 100mm x 74.1mm standard board)
10x1mm terminal pins
2xclip-on finned heat sinks, approx 40°/W, TO220 type
knobs for VR1 and VR2
Sockets to fit adaptor plugs (optional)
Fuses and fuse-holders, optional

Practical Electronics is giving away up to £2,000 Pounds to its readers!

Celebrate the beginning of Summer with some new equipment, and PE could be paying for it.

We're offering to refund 10 readers of Practical Electronics up to £200.00 for purchases made from advertisers in this issue (including all products from our advertisers' catalogues like Maplin, Greenweld etc.)

The rules are simple:

Buy any product from any advertiser and we will refund you all or part of the cost, up to a maximum value of £150, or £200 if you are a subscriber.

All you have to do is complete and cut out the coupon below and send it to us with proof of purchase. Then if you are one of the lucky readers drawn out of the bag, we will refund your money.

Needless to say, this is one offer you really can't afford to refuse!

Buy any product from any of our advertisers!

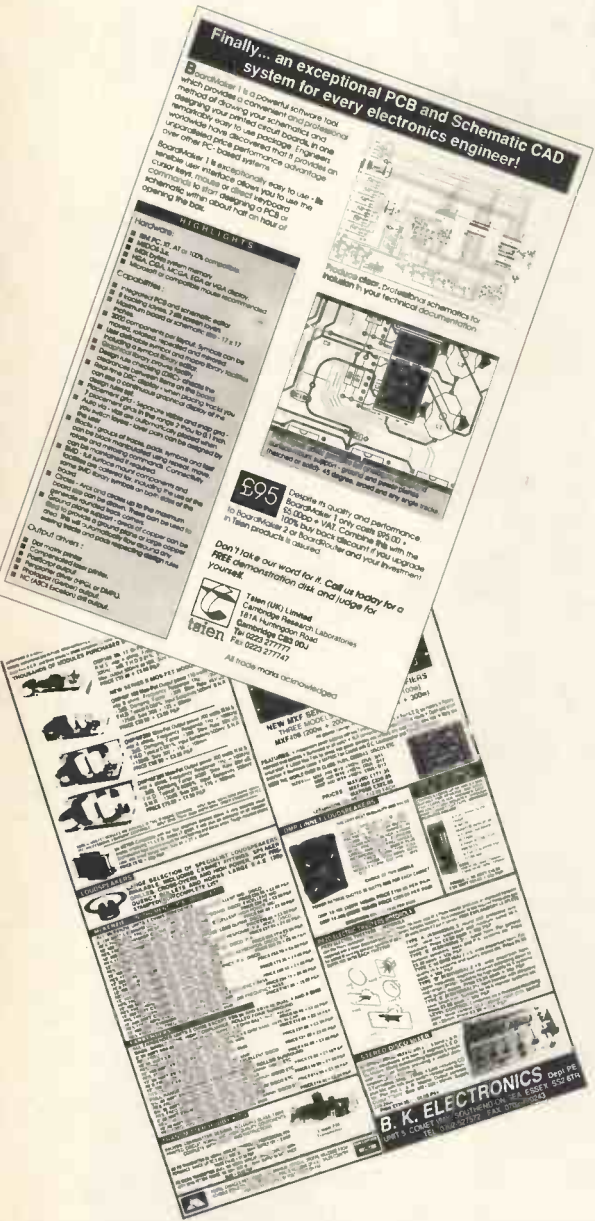

Send to: PE Reader Loyalty Bonus, May 1991
Intra Press, 103 Uxbridge Road, London W12 9RA

I purchased price.....
as advertised by

Name

Address.....

Town..... Postcode.....

I am a Subscriber Complete and return this coupon by May 31st. The winners will be announced in the August issue of PE.

The 6522 VIA

Possibly one of the most useful chips available to a microprocessor system designer, Data Sheet looks at the device used to talk to the real world in the BBC micro.

Designed to make life easy for programmers, the 6522 Versatile Interface Adaptor is also an easy device to attach to a microprocessor system. This month's data sheet takes a close look at the chip, its operation and capabilities.

Pin connections

Pin	Name	Description
1	Vss	Ground, usually set to 0V.

2-9 PA0-7 Data port A. Any of the pins can operate either as in or out depending on the settings in the data direction register. When set for output, a '1' bit written to data register A will appear as a +5V signal on the appropriate pin. A '0' bit sets the pin to 0V. If a '1' output is pulled low by an external load while in output mode, reading from data register A will return the low ('0') rather than the actual setting. The same applies to lines pulled high when they are set low – see PB0-7. When used as input, the value read from data register A will correspond to the voltage level on the pin; 5V gives a '1' and 0V gives a '0'. When latching is disabled, the value read in is the value at the port. Using the CA1 latch will only read in the data on the port when the latch was set, regardless of what voltage levels are actually present.

10-17 PB0-7 Data port B, is similar to that of pins 2-9 with the exception that data direction is controlled by data direction register B and latching by CB1. Unlike port A, the data read from port B when it is set to output is that which was written to it. For example, setting PB0 to out and then writing a '1' to it sets the PB0 pin to +5V. If a load pulls this down to 0V, reading from PB0 will still return a '1' – unlike port A where a '0' would be read in. Bit seven of this port (PB7) can also be controlled by timer 1 which

uses it as an output for one-shots and square waves. Bit six can be used by timer 2 as an input to count it down to zero.

18 CB1 Control line B one, used to generate interrupts, handshakes and control the shift register. For more information, see the register descriptions.

19 CB2 Control line B two, similar to CB1 but providing more flexible operation.

20 Vcc Supply pin, usually set to +5V.



21 $\overline{\text{IRQ}}$ Interrupt request, is sent low when an internal interrupt flag and the interrupt enable bit is set. This output is usually connected to the microprocessor interrupt input.

22 $\overline{\text{R/W}}$ Read/Write, used to transfer data to and from the 6522 along the microprocessors data bus. When high, it indicates that data is being transferred out of the 6522 (a read) and low defines data being transferred in (write). This line has no effect unless the 6522 has been selected by setting CS1 high and $\overline{\text{CS2}}$ low.

23 $\overline{\text{CS2}}$ Chip select two is

used in conjunction with CS1 such that when both are true – CS1 = '1' and $\overline{\text{CS2}}$ = '0' – the 6522 becomes active on the data bus and data can be read from or written to it.

24 CS1 Chip select one. See pin 23.

25 ø2 Phase two clock. All of the internal operations are governed by the timing on this pin. Its name derives from the 6502 clock designations ø1 and ø2 which are 50% duty cycle square waves exactly out of phase with each other. The transfer of data is also regulated by this clock and is only moved when it is high.

26-33 D7-D0 Data bus. Transferring data to and from the 6522 to the main microprocessor takes place over this bus. This actually happens when R/W is correct and ø2 is high.

34 $\overline{\text{RST}}$ Reset. Sending this low clears all internal registers to zero apart from timers one, two and the shift register.

35-38 RS3-RS0 Reg select. These are normally connected to the address bus of the microprocessor and are used to select which of the 16 internal registers are to be written or read. For example, connecting them to the lowest four bits of the address bus and then using the chip select signals to specify a base address (the complete address minus the bottom four signals) at which they become active means that the internal registers will be at base address+0 to 15 consecutively.

39 CA2 Control line A two. This are similar to CB2 except that it may be used in conjunction with port A instead.

40 CA1 Control line A one. Again, this is similar to CB1 but is used with port A.

Internal registers

0 DRB

PB7	PB6	PB5	PB4	PB3	PB2	PB1	PB0
-----	-----	-----	-----	-----	-----	-----	-----

Data register B.

Port B is functionally very similar to port A (see reg 1) except that handshaking occurs through CB1 and CB2.

1 DRA

PA7	PA6	PA5	PA4	PA3	PA2	PA1	PA0
-----	-----	-----	-----	-----	-----	-----	-----

Data register A.

This connects directly the pins PA0 to PA7. Each bit can be either in or out depending upon the setting of DDRA. Write handshaking is performed with CA1 and CA2 such that as soon as data is written to this register, CA2 goes low. Data is acknowledged by the external device setting CA1 low which then send CA2 high again and sets the appropriate interrupt flag (CA1). An alternative mode pulses CA2 low for one clock period of $\phi 2$. This enables the microprocessor to transfer data under interrupt control at a speed defined by the external hardware – as soon as the data is taken, the processor is informed and more data can be set up. For read handshaking CA1 is used to latch the data into the port and generate an interrupt to let the microprocessor take the data.

2 DDRB

DB7	DB6	DB5	DB4	DB3	DB2	DB1	DB0
-----	-----	-----	-----	-----	-----	-----	-----

Data direction register B.

Setting individual bits to '1' or '0' defines which of the pins in data register B are input and output. A '0' defines the pin to be input making it high impedance to external hardware. A '1' makes the pin output the value written to data register B. for example, with DDRB holding the value 128, pins PB0 to PB6 will be input and PB7 output. Writing 255 to DRB sets PB7 high but has no effect on PB0 to PB6 unless their directions are changed.

3 DDRA

DA7	DA6	DA5	DA4	DA3	DA2	DA1	DA0
-----	-----	-----	-----	-----	-----	-----	-----

Data direction register A.

This operates in exactly the same way as DDRB except that it works for DRA.

4 T1C-L

Timer one write low byte latch, read low byte counter.

Writing to this register will load the eight data bits into timer 1's low order

latches. As a 16-bit timer/counter both high and low bytes must be transferred before it can start counting. Reading from this register gets the current value of the low eight bits of the timer and the T1 interrupt flag is cleared.

5 T1C-H

Timer 1 high byte write, low byte transfer and count trigger.

The high eight bits of the latches of timer 1 are loaded with the data written to this register. The contents of both the low and high order latches are then transferred and the T1 interrupt flag is cleared (to zero). If the timer is in free run mode, counting will start from the new value.

6 T1L-L

Time 1 write low byte latch, read.

Writing to register operates in the same way as for register four. Reading from it transfers the data from the low byte of the counter to the data bus and hence to the microprocessor. Unlike register four, however, the T1 flag is not cleared.

7 T1L-H

Timer 1 high byte latch write, read.

Data written to this register is placed into the high order latches but no transfer to the counter is made until it times out and restarts when both low and high bytes are reloaded. Reading from this register gets the contents of the high order latches.

8 T2C-L

Timer 2 low byte latch write, read.

Timer 2's low order latches are loaded with data written to this register. Any reads return the data from the low order counter and clear interrupt flag T2.

9 T2C-H

Timer 2 high byte write, low byte transfer, read high byte.

This register serve to connect directly to the high order counter of timer 2 since writing loads the counter and transfers the low byte. The T2 interrupt flag is also cleared. Reading transfers the high eight bits of the counter to the microprocessor.

10 SR

Shift register

The shift register has eight operating modes. The first (0) disables it although data can still be read or written and data will be shifted left from CB2 on each CB1 positive edge. The SR interrupt flag is disabled in this state.

Logic diagram.

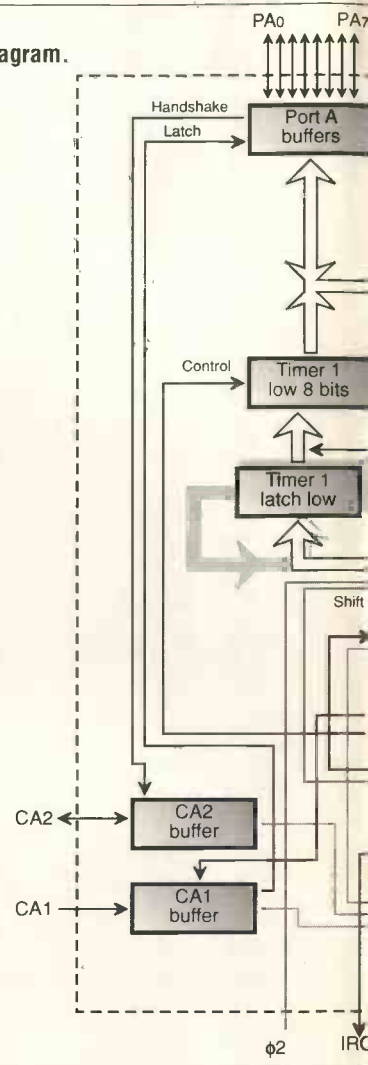

Mode 1 uses the low eight bits of timer 2 to control the shift-in rate. Timing pulses are output on CB1 to allow external devices to synchronise with the bit stream and the time between each transition is controlled by the value on the low order latch of T2. Reading or writing the SR when the SR interrupt flag is set will trigger a shift operation. Otherwise the first shift happens when T2 times out. Eight bits are shifted in from CB2 and the SR interrupt flag is set, stopping any more shifts until a read or write of the register takes place. This allows 8-bits of data to be read in at a set rate after which the microprocessor is notified and can read the new byte. Note that data is shifted in on the positive edge of CB1.

Mode 2 shifts in from CB2 under control of the system clock $\phi 2$ and pulses for external synchronisation are output on CB1. After the shift register is read, data will be read in at one bit per $\phi 2$ clock transition for a total of eight bits. At this point the SR interrupt flag is set and operation ceases until the register is read again.

Mode 3 shift data in from CB2

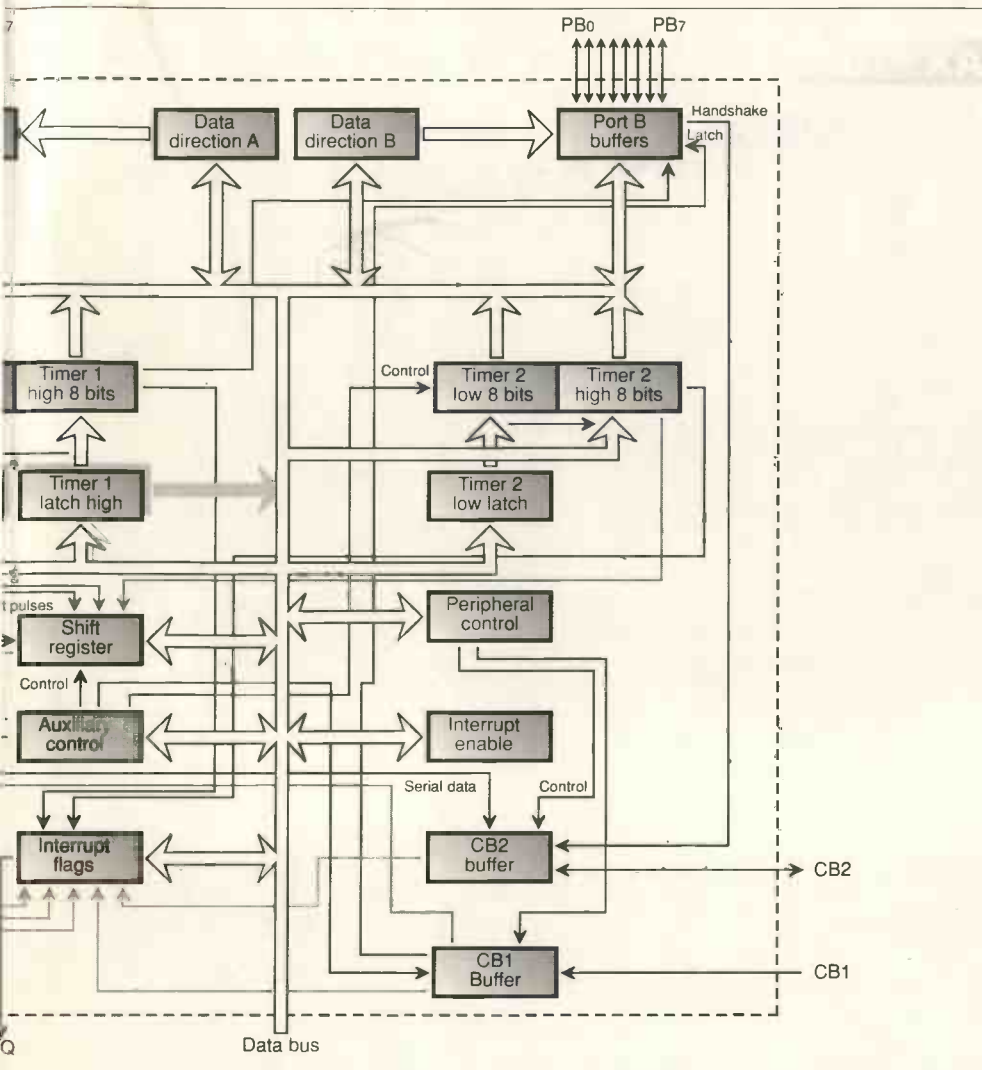

Peripheral control.

CA1, CA2, CB1 and CB2 are controlled by this register. Bit zero defines the interrupting edge of CA1, bits 1 to 3 the operation of CA2, bit 4 the edge of CB1 and bits 5 to 7 how CB2 is used.

13 IFR

CA2	CA1	8 shifts	CB2	CB1	T2	T1	IRQ
-----	-----	----------	-----	-----	----	----	-----

Interrupt flag register.

Various operations within the 6522 generate interrupts. These are flagged in this register with bit seven being a master flag which indicates that an interrupt has occurred – the reason for it being bit seven is that many 8-bit microprocessors automatically test this bit when the value is loaded. This gives a quick easy check to see if an interrupt occurred. The flags can be cleared by reading or writing the various registers associated with the flags or by writing a '1' to the relevant bit in the IFR. This doesn't work with bit 7 since this will only clear when no interrupts are present. Interrupt flags will only be set if enabled in the IER. The CA2 and CB2 lines have an independent interrupt function and flags set by them can only be cleared by writing to the IFR.

14 IER

Interrupt enable register.

Bits set (to '1') in this register (apart from bit 7) enable their respective interrupts. Control is unusual in that writing to this register uses bit seven to indicate whether bits should be cleared or set. For example, to set bits zero and four (enable flags CA2 and CB1) the byte 145 is written. Bit seven, when set, defines that all flags denoted by '1' in the byte should be set. If bit seven is clear then bit set in the byte will clear their respective enables – to use the same example, writing 17 to the IER clears enables 0 and 4. Reading from the register always returns the state of the bits with bit seven always set to '1'.

15 DRA

Data register A without handshake

This operates in exactly the same way as DRA but CA1 and CA2 perform no handshaking functions.

Electrical specification

Port B can source 1mA at 1.5V
 Min logic 1 input voltage = 2.4V
 Max logic 0 input voltage = 0.4V
 Min input current = 1.8mA
 Min logic 1 output voltage = 2.4V
 Max logic 0 output voltage = 0.4V
 Min current sink capability = 1.6mA

under control of clock pulses on CB1. This allows external hardware to control the speed of transfer. This SR interrupt will be generated after eight pulses and is reset by reading the register. Shifts are not stopped by the flag being set and shifts occur on positive edges of CB1.

Mode 4 shifts out onto CB2 under control of T2 in free running mode. After writing data to the shift register, shifts take place continuously with the eight bits being output repetitively. As usually, CB1 outputs the shift clock pulses.

Mode 5 also shifts out to CB2 under control of T2 but if the SR interrupt flag is set nothing happens until the SR is read or written or T2 times out. After eight shifts, the SR interrupt flag is set (to one) and shifting stops. The shift pulses are output on CB1 to help with external synchronisation.

Mode 6 uses the system clock to shift the data at CB2 into the shift register. This is similar to mode 2 except for the direction of the transfer.

Mode 7 shifts data in from CB2 under control of CB1. Operation is similar to mode 3.

11 ACR

7	6	5	4	3	2	1	0
---	---	---	---	---	---	---	---

T1 control
 00 Int when loaded PB7 off
 01 Cont int PB7 off
 10 Int when loaded PB7 one shot
 11 Cont int PB7 square wave

T2 control
 0 Timed interrupt
 1 Count pulses on PB6

Shift reg control
 000 Disable
 001 Shift in under T2
 010 Shift in under a2
 011 Shift in under CB1
 100 Shift out under free run T2
 101 Shift out under T2
 110 Shift out under a2
 111 Shift out under CB1

Port A latch enable
 Port B latch enable

Auxiliary control register

Control of the timers, latches and the shift register are undertaken by this register. Bits 0 and 1 enable the latches for ports A and B respectively – set to 1 to enable. Bits 2 to 4 define which mode the shift register is to operate in. Bit 5 controls timer 2 and bits 6 and 7 timer 1.

12 PCR

7	6	5	4	3	2	1	0
---	---	---	---	---	---	---	---

CA2/CB2 control
 000 Input -ve active edge
 001 Independent -ve edge int
 010 Input +ve active edge
 011 Independent +ve edge int
 100 Handshake out
 101 Pulse out
 110 Low out
 111 High out

CB1/CA1 interrupt control
 0 Negative edge
 1 Positive edge

The Capacitor

For something so simple, the capacitor has a myriad of uses and is indispensable in electronic circuits from filters to microprocessor systems.

After resistors, capacitors are probably the second most widely used electronic component. In their basic form they consist of two metal plates separated by an insulator or dielectric, see Fig. 1. Applying a direct current fills up one plate with electrons making it negative with respect to the other plate which becomes positive. When the supply voltage is removed, the charge leaks away through the dielectric, the casing and the metal connections. For larger capacitors most of the leakage is through the dielectric so its structure and material is quite important.

The permittivity of a material is the ratio of the capacitance of a capacitor using the material and the capacitance of the same capacitor using a vacuum. Charges in a dielectric are displaced by the electric field – negative charges go towards a positive field and vice versa. Dielectrics with a high permittivity have easily polarised charges that create a polarisation effect that opposes the applied field drawing more charge onto the electrodes. A list of common permittivities is shown in table 1.

Capacitors are normally classified by the type of insulator used in their construction. Table 2 gives a list of most of the common types with their capacity ranges.

AC/DC

Capacitors find a number of uses in electronic circuits, they block direct current and allow alternating current through. However, they also react to AC in a way that depends upon the frequency. The following formula defines the impedance or reactance of a capacitor:

$$X_c = 1 / (2\pi f C) \Omega$$

where C is the capacitance and f the frequency. One of the useful results of this is that the impedance varies with the frequency and, depending upon the configuration of the circuit, filters that pass low frequencies only (low pass) and filters that pass high frequencies only (high pass) can be created as in Fig. 2.

Structure

Capacitors are made in a number of ways and probably the simplest use impregnated paper or plastic placed between two pieces of metal foil which form the plates. All of this is rolled up to make it as small as possible. An alternative is to stack the plates and connect them in parallel, a technique used to produce sturdier devices from less flexible materials. To get different ranges and performances, various dielectrics are used (see table 3). The voltage rating of a capacitor is important because if exceeded, it will cause arcing between the plates which will destroy the dielectric. The insulation resistance of the dielectric is therefore quite important as well as being dependent upon the operating

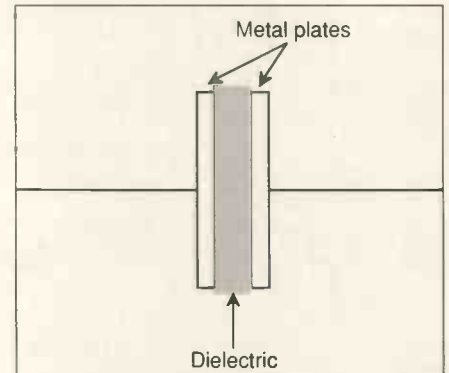

Fig. 1. Basic capacitor.

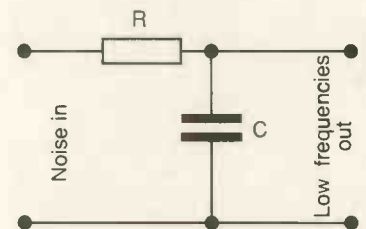

Fig. 2a. Low pass filter.

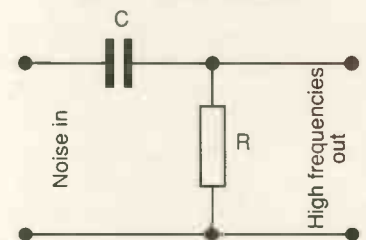

Fig. 2b. Low pass filter.

conditions. For non-sealed capacitors, high humidity and temperatures can cause deterioration of the insulator to the stage where it will stop working. Sealed capacitors don't suffer as much but are still prone to temperature disruption.

The Farad

The values of capacitors are measured in Farads which in turn are defined in terms of the voltage and charge on the device. These are related as follows:

$$C = Q/V$$

where C is the capacitance in Farads, Q the charge in coulombs and V the voltage in Volts. A Coulomb is the unit of electrical charge with one electron being 1.602×10^{-19} coulombs. Unfortunately, the Farad is rather a large amount so capacitances are usually given in micro farads or μF (10^{-6}), nano farads or nF (10^{-9}) or pico farads or pF (10^{-12}).

Aluminium oxide	7
Ceramics	35 to 6000+
Dry air	1.0001
Polystyrene	2.5
Polythene	3.3
PTFE	2
Tantalum oxide	11
Vacuum	1

Table 1. Some common permittivities.

Glass	0 – 1μF
Mica	0 – 1μF
Ceramic	0 – 1μF
Polythene	.001 – 10μF
Polystyrene	.001 – 10μF
Polyester	.001 – 10μF
Polycarbonate	.001 – 10μF
Solid tantalum	.01 – 102μF
Wet tantalum	.05 – 2x102μF
Tantalum foil	.1 – 103μF
Aluminium electrolytic	.1 – 106

Table 2. capacitance ranges.

To get very high capacitance in a reasonably small volume, electrolytic capacitors use aluminium foil sandwiched in an electrolyte as in Fig. 3. The only drawback is that this type of device must be connected the correct way around. The schematic symbol for a normal capacitor is shown in Fig. 4 with the electrolytic next to it. The plate shown as a solid bar is the negative terminal and the hollow one the positive, connected to the positive side of the circuit.

To get the required value for a

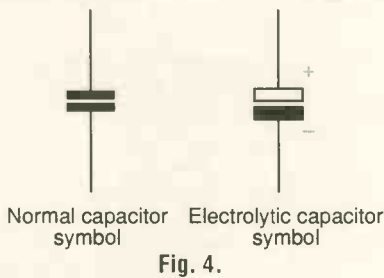
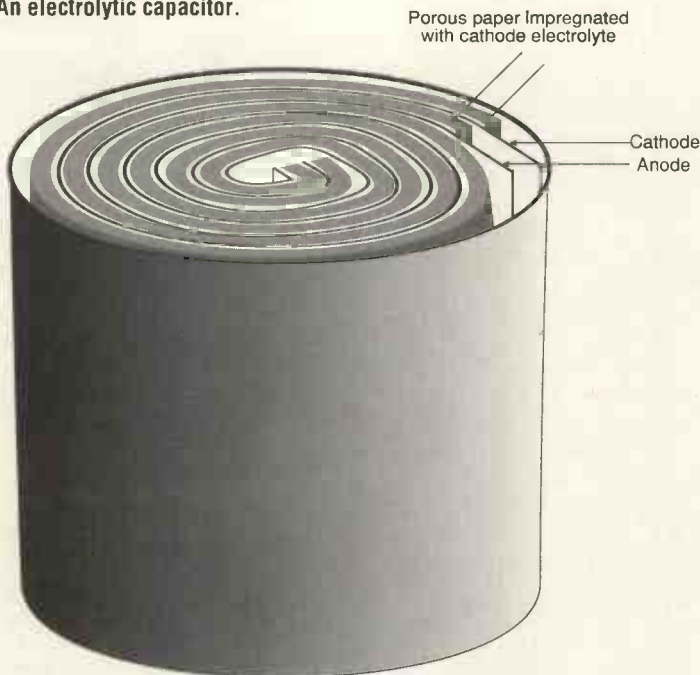

Fig. 4.

Fig. 3. An electrolytic capacitor.



Coupling – in series, blocks DC but allows AC through
 Bypass – in parallel forms a low impedance path to ground
 Tuning
 Timing – RC tuned circuits
 Ripple suppression – absorbs peaks in supply
 Arc suppression – reduces or absorbs noise
 Energy storage – creates high currents in a short time
 Power factor correction – uses phase change

Table 4. Capacitor usage.

circuit, capacitors can be connected in series or parallel as shown in Fig. 5 – note that this is the opposite to resistor combinations. ■

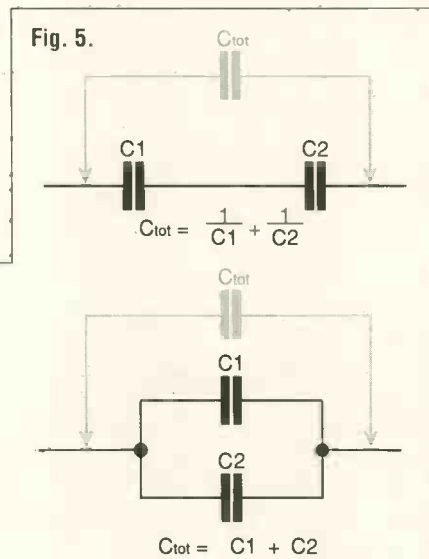

Fig. 5.

Mica
 High frequency coupling, timing and filters
 Reliable
 1pF to 1μF
 100V to 2000V
 Tolerance ±5% to ±5%

Low loss ceramic
 As for mica but better operation at high temperatures
 Small size
 10pF to 4.7μF
 50V to 100V
 Tol. ±1% to ±20%

Disk ceramic
 Coupling, bypass in radio and intermediate frequencies
 Cheap
 1pF to .22μF
 3V to 10 000V
 Tol. ±20% to ±100%

High voltage ceramic
 High voltages and radio frequencies
 180pF to 16000pF
 6V to 40kV
 Tol. +50% to -20%

Plastic (PTFE, polycarbonates, etc.)
 General purpose
 .001μF to 22μF
 30V to 400V
 Tol. ±25% to ±10%

Mylar film and paper
 General purpose AC
 Very low leakage
 .001μF to 10μF
 50V to 600V
 Tol. ±5% to 10%

Aluminium electrolytics
 Filters
 Cheap, polarised
 1μF to 270 000μF
 3V to 450V
 Tol. -20% to +100%

Tantalum
 Rugged small high value
 Normally polarised but non-polar also available
 1μF to 1200μF
 3V to 300V
 Tol. ±5% to 20%

Table 3. Capacitor Specifications.

The Time Has Come For Many Things...

Accurate time and frequency measurement is vital to the electronics designer. Anthony H Smith BSc starts of the PE Chronos project with a look at the specifications..

Why name a universal counter timer (UCT) Chronos? Well, certainly not to pretend that it is the god of all such instruments – it has many limitations and certainly can't do everything. Instead, the UCT to be described over the next few months will represent a highly versatile piece of test gear, capable of carrying out the vast majority of time and frequency measurements encountered in both amateur and professional work.

The Chronos, although not being especially difficult to build, is not really intended for the raw beginner, so if you've any doubts about your constructional capabilities, it may be best to consider a simpler counter timer project to whet your appetite. Also, the Chronos can't be tested and calibrated using only an old voltmeter – you'll need access to a good 10MHz oscilloscope (preferably dual trace), and a signal generator, logic pulser and logic probe will be required at various points along the way. It's not the

kind of project that can be knocked up in a weekend – be prepared to spend plenty of time getting it just right.

What's In The Box

The specifications of Table 1 introduce the sixteen measurement functions available on the Chronos. For each function, any one of four range settings can be selected; the particular range chosen determines both the speed and resolution of the measurement, and in certain cases determines the accuracy, too.

The required function is selected using either of two front panel pushbuttons; pressing the up button steps the functions up from 1 to 16, whereas the down button steps the functions in the opposite direction. The particular function selected is indicated by one of sixteen front panel LEDs. Similarly, the required range is chosen by a single button which steps through the settings from 1 to 4, with one of four LEDs indicating the chosen range.

For any of the functions selected, a particular unit's LED will be illuminated, indicating the relevant units (seconds, microseconds, kilohertz, hertz or megahertz) for the measurement being made.

The Chronos has three input signal channels, A, B and C with most measurements being carried out using channels A and B. Channel C is reserved for VHF frequency measurements. Channels A and B are identical, each channel has a variety of controls which allows the operator to set up optimum measurement conditions for the particular signal being measured. Channel C, on the other hand, has no user controls, and simply amplifies and prescales the input signal to bring it within the counter's range.

Returning to Table 1, selecting function 1 displays the frequency of the signal at input A, whereas function 2 displays the frequency at input B. Any signal in the frequency range DC (direct current) to 10MHz can be accommodated. However, this is only a minimum bandwidth – in practice, you may find that inputs A and B can trigger on frequencies slightly greater than 10MHz.

For functions 1 and 2, the range selected determines the gate time, the time the counter's main gate is open, and thus the length of time to complete the measurement, and also the measurement resolution. Thus, for example, measuring a signal of 1.234kHz on range 1 will take only 10 milliseconds and will be displayed as 1.2kHz. If range 4 is selected, the same signal will be displayed as 1.2345kHz, but will take 10 seconds to measure.

With functions 1 or 2 selected,

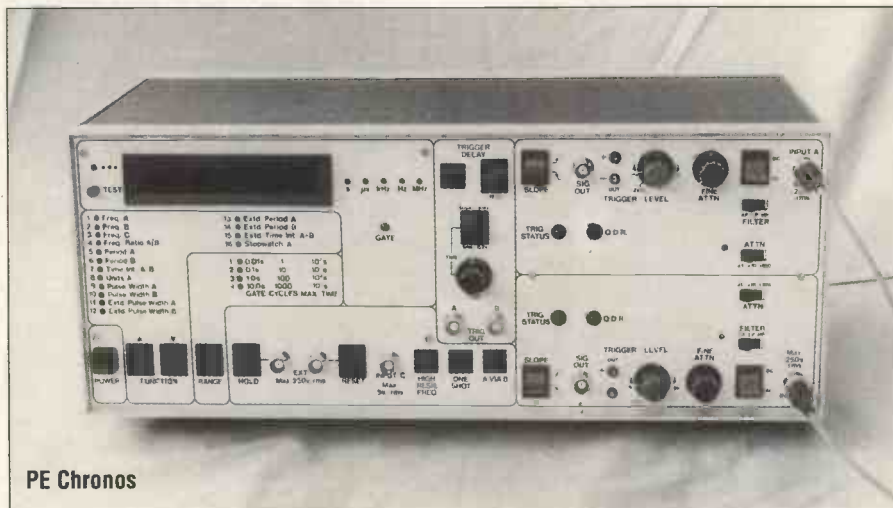

frequency at input C. This can take any value in the range 1MHz to 100MHz, although this is only a nominal range and the maximum measurable frequency is likely to be as much as 150MHz, or more. All frequencies are displayed in MHz, and, once again, the range selection determines the gate time and resolution.

Three Channels

Channels A and B can perform a wide variety of measurements on lower frequency signals and there are several reasons why two identical channels are used. Firstly, they allow for rapid comparison of different signals. By connecting inputs A and B to different circuit nodes, the frequencies at both can be compared simply by changing from function 1 to function 2, and vice-versa.

A second, and perhaps more important, reason for having two channels arises from the need to make measurements on a parameter based directly on a particular relationship between the two signals. The time interval between two signals is one example. Another is frequency ratio – by selecting function 4, the ratio between the frequencies at inputs A and B is computed such that the display reads:

$$\frac{\text{frequency at A}}{\text{frequency at B}}$$

For this function the maximum frequency at input A is 10MHz, whilst that at input B is limited to 2MHz. (The display in this case would read $10,000,000/2,000,000 = 5$).

For cases where the frequency at A is much greater than that at B, the ratio will be much larger, the maximum being 108:1 = 99,999,999. By choosing a higher range, the number of cycles at input B over which the measurement is averaged is increased, as is the resolution of the reading. Also, since the accuracy of this function is limited only by the +1 count error, a tenfold increase in resolution (say from range 2 to range 3) will cause a tenfold reduction in the relative magnitude of 1 count, and thus a tenfold increase in the reading's accuracy.

Note that increasing the range

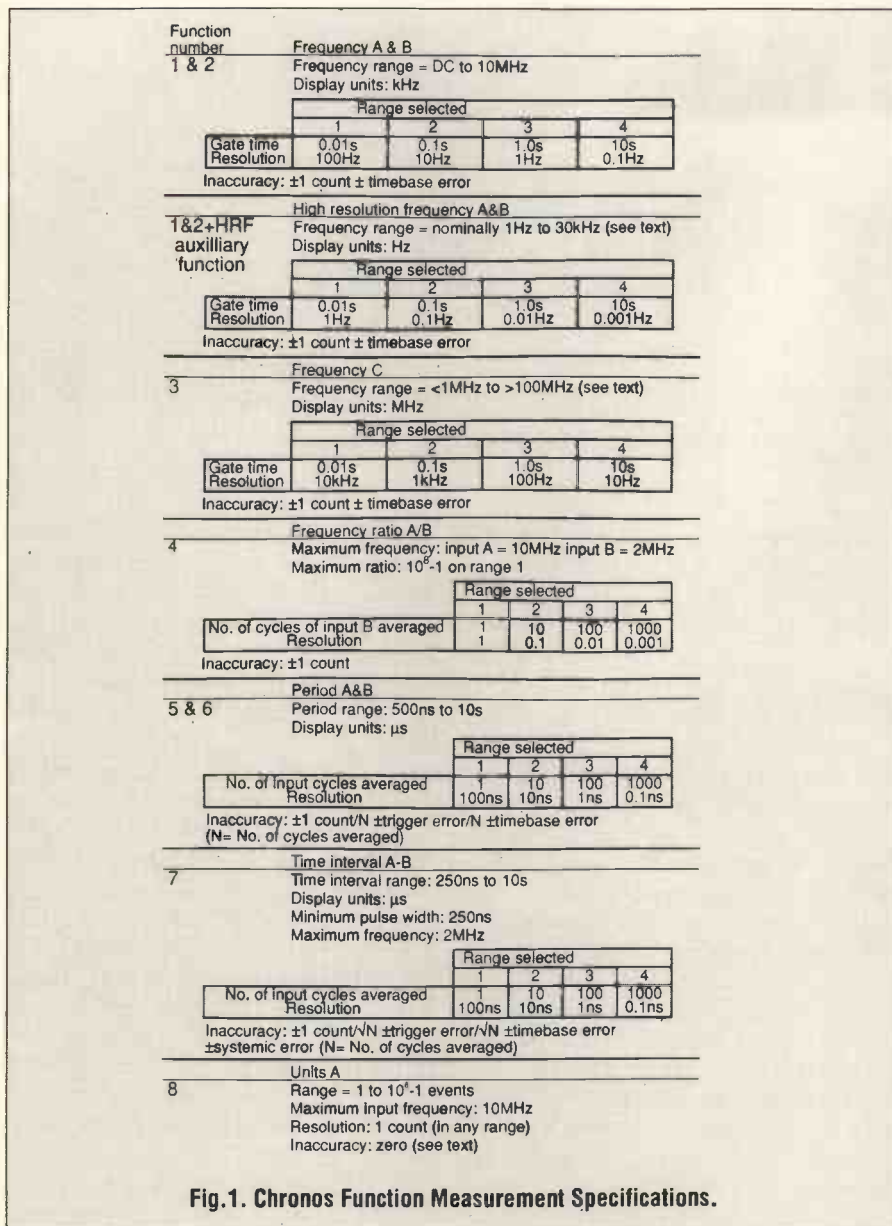

Fig.1. Chronos Function Measurement Specifications.

all frequencies are displayed in kilohertz units – an input of 23Hz will be displayed as .023kHz, whereas an input of 7.654321MHz will be displayed as 7654.321kHz. The measurement error for functions 1 and 2 is a combination of quantisation and timebase error.

High Resolution

Ranges 1 and 2 can be selected to make relatively quick, low resolution measurements (for example, measurements of frequencies which are varying with time), whereas high resolution measurements (ranges 3 and 4) can be achieved only by sacrificing measurement speed.

Fortunately the Chronos features a special auxiliary function, namely High Resolution Frequency (HRF), which increases the resolution by a

factor of 100, without increasing the measurement time. Thus, by selecting HRF and range 1, a 1.2345kHz signal can be displayed as 1234Hz, whilst still taking only 10 milliseconds to measure.

Note that HRF can only be used to increase the resolution of signals in the range 1Hz to 20kHz – higher frequencies cannot be accommodated. When selected, HRF displays the frequency with units of hertz, and only applies when functions 1 or 2 are selected – for functions 3 to 16, HRF has no effect, and cannot accidentally corrupt the measurements. The accuracy of an HRF is the same as for a standard frequency measurement.

Very High Frequency

Selecting function 3 measures the

will increase the measurement time. For instance, say the period of input B is 0.1s. In range 1, the measurement will take $1 \times 0.1s = 0.1s$, whereas for range 4, it will take $1000 \times 0.1s = 100$ seconds.

In The Interval

As well as being able to measure frequencies, Chronos can cope with other parameters as well. By selecting function 5 or 6, the period of the signal at A or B, respectively, can be measured. Any period in the range 500ns to 10s can be accommodated and will be displayed as so many microseconds (for example, a period of 5.6789ms will be displayed as 5678.9 μ s).

Like the frequency ratio function, selecting a higher range will increase the number of input cycles over which the measurement is averaged. This will increase the resolution and reduce the measurement error since the ± 1 count error and \pm trigger error are both reduced by the factor N, where $N = 1, 10, 100$ or 1000 for ranges 1, 2, 3 and 4 respectively. The timebase error is not reduced by period averaging.

There are many cases where the length of time between two points on different waveforms needs to be measured. Function 7 allows this for the signal at input A followed by any point on the signal at B – the length of this interval can be anything from 250ns to 10s, and is displayed as microseconds.

For the Chronos to measure time intervals correctly, the width of the pulses at inputs A and B must be no less than 250ns, and they must occur at a frequency no greater than 2MHz.

Once again, the range switch can be used to increase the number of intervals averaged, with a corresponding increase in resolution (and measurement time). Note that the ± 1 count error and trigger error are reduced only by the square root of the factor N.

Eventful Counting

Selecting function 8 puts the Chronos into units counting mode, where each event occurring at input A is clocked up on the display. An event is any signal which causes channel A to trigger. For example, it could be derived from the closing of

Function number	Pulse width A & B			
9 & 10	Time interval range: 250ns to 10s Display units: μ s Minimum pulse width: 250ns Maximum frequency: 2MHz			
	Range selected			
No. of pulses averaged	1	2	3	4
Resolution	100ns	10ns	100ns	1000ns
Inaccuracy: as per time function				
	Extended pulse width A&B			
11 & 12	Pulse width range: 2 μ s (min), max depends on range Display units: seconds Maximum input frequency: 350kHz			
	Range selected			
Max desirable pulse width	1	2	3	4
Resolution	100s	1000s	10ks	100ks
	1 μ s	10 μ s	100 μ s	1ms
Inaccuracy: ± 1 count \pm trigger error \pm timebase error \pm systemic error				
	Extended period A & B			
13 & 14	Period range: 1 μ s (min), max depends on range Display units: seconds			
	Range selected			
Max measurable period	1	2	3	4
Resolution	100s	1000s	10ks	100ks
	1 μ s	10 μ s	100 μ s	1ms
Inaccuracy: ± 1 count \pm trigger error \pm timebase error				
	Extended timer interval A-B			
15	Time interval range: 2 μ s (min), max depends on range Display units: seconds Minimum pulse width = 100ns Maximum frequency = 500kHz			
	Range selected			
Max measurable interval	1	2	3	4
Resolution	100s	1000s	10ks	100ks
	1 μ s	10 μ s	100 μ s	1ms
Inaccuracy: ± 1 count \pm trigger error \pm timebase error \pm systemic error				
	Stopwatch A			
16	Timing range: 1 μ s to 100ks Display units: seconds			
	Range selected			
Max measurable time	1	2	3	4
Resolution	100s	1000s	10ks	100ks
	1 μ s	10 μ s	100 μ s	1ms
Inaccuracy: ± 1 count \pm trigger error \pm timebase error				

Fig.1. Chronos Function Measurement Specifications cont.

a switch, the output from a sensor, relay contacts and so on.

Events can occur at any rate up to a maximum of 10MHz (ten million events per second), and the Chronos can display a maximum of 99,999,999 events before it overflows.

Finger On The Pulse

Functions 9 and 10 allow the Chronos to measure the duration of any pulses occurring at inputs A and B, respectively, provided the pulses are no shorter than 250ns, no longer than 10s, and do not occur at a rate in excess of 1MHz.

The range selection affects the resolution, measurement time and accuracy in just the same way as for time interval measurements, and the pulse width is displayed in microseconds.

Extensions

The time measurements of functions 5,6,7,9 and 10 are intended for applications requiring high resolution readings of time periods as short as 250ns.

Unfortunately, these functions are limited to periods no greater than 10s, which in many cases is just not long enough. Consequently, six long-range functions have been incorporated into the Chronos to increase the range of time measurements to more than 27 hours.

Functions 11 and 12 are extended pulse width functions at inputs A and B respectively and permit the measurement of any pulse as narrow as 2 μ s, or lasting as long as 100,000s. These functions are intended to measure the duration of long term events. For example, the length of time a process is in operation, the time it takes to complete a chemical reaction, the length of time a sensor is activated and so on.

Pulse width averaging is not available (it would take far too long, anyway, averaging 100 twenty-second pulses would take over half an hour). Instead, the selected range determines the resolution and maximum length of the measurement – the higher the range the longer the measurement can be, but with a corresponding reduction

Aux functions

High resolution frequency:

Operates with functions 1 and 2 (frequency A & B). Increases the resolution of frequency measurement by a factor of 100. Available for low frequency inputs only.

Trigger delay:

With this activated, the counter ignores re-triggering during the set delay time. Range: 1 50µs to 5ms, 2: 5ms to 200ms. Range 1 or 2 selected by front panel switch and varied by front panel potentiometer control.

Read-out: the set delay time is indicated by operating the read switch.

Trigger outputs:

Buffered replicas of digital signals from channels A and B available at two front

panel BNC connectors (short circuit protected).

One shot:

Puts the counter into a single event mode, such that the first in a series of measurements is held on the display – all subsequent events are ignored.

A gated via B:

Allows the triggering of A by Input B.

Hold:

Operating this freezes the display at the value of the current measurement. Hold can be selected by:

Front panel pushbutton – the first press activates hold, the second releases it.

Front panel BNC input: active low input, protected to 250V RMS maximum, TTL/CMOS compatible.

Reset:

Halts any measurement in progress, sets the display to zero and prepares the counter for the next measurement. Reset also doubles as a priming control for functions 7, 9 and 10 (see text). It is also selected by:

Front panel pushbutton – counter is reset only while the button is pressed.

Front panel BNC input: active low input, protected to 250V RMS, TTL/CMOS compatible.

Display test:

Front panel pushbutton enables all display segments giving a display of all eights with decimal points and illuminates the overflow LED.

Table 2.

in resolution.

The period of any signal in the range 1µs to 100,000 seconds can be measured by selecting functions 13 or 14. Once again, the reading is displayed in seconds and the selected range determines the resolution and maximum possible value of the measurement.

By choosing function 15, a similar type of measurement can be made on completely different

signals. When selected, this function allows the Chronos to display the time interval between an event at input A followed by an event at B. Provided these events are at least 100ns wide and do not occur at a rate greater than 500kHz, any interval in the range 2µs to 100,000 seconds can be measured.

Perhaps the most obvious application for this type of measurement is in the timing of a

race. If the firing of the starter pistol is the event at A, and the breaking of the finishing tape is the event at B, the winning time can be measured down to the last microsecond with range 1 selected.

Stopwatch Operation

A more familiar device for measuring a race is a stopwatch, and by selecting function 16 the

Interak 1 SINGLE BOARD COMPUTER "SBC-1"

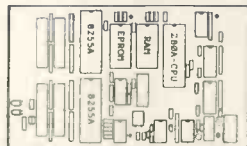

A computer doesn't *have* to look like you'd expect a computer to look. It doesn't *have* to have a keyboard and a screen and floppy disks and so on.

The SBC-1 has the bare minimum of chips a Z80 computer can have and still be a computer: A 4 MHz Z80-CPU chip, an EPROM chip (up to 32K), a static RAM chip (up to 32K) and a pair of 8255A I/O (input/output) chips giving 48 individual lines to waggle up and down. There are one or two additional "glue" chips included, but these are simple "74LS" or "HC" parts.

A star feature is that no special or custom chips (ie PALs, ULAs, ASICs etc) are used — and thus there are no secrets. The Z80A is the fastest and best established of all the 8-bit microprocessors — possibly the cheapest too!

Although no serial interface is included, it is easy for a Z80A to waggle one bit up or down at the appropriate rate — the cost is a few pence worth of code in the program: why buy hardware when software will do?

Applications already identified include: Magnetic Card reader, mini printer interface, printer buffer, push button keypad, LCD alphanumeric panel interface, 40-zone security interface for auto sending of security alarms, code converter (eg IBM PC keyboard codes to regular ASCII), real time clock (with plug in module), automatic horticultural irrigation controller.

By disabling the on-board Z80A-CPU this card will plug into our Interak 1 CP/M Plus disk-based development system, so if you don't fancy hand-assembling Z80 machine code you don't have to!

The idea is (if you are a manufacturer) you buy just one development system and then turn out the cheap SBC-1 systems by the hundred. If you are really lazy we can write the program for you and assemble the SBC-1 cards so you can get on with manufacturing your product, leaving all your control problems to us.

Greenbank

For more details write or phone us:
Greenbank Electronics, Dept PE05, 460 New Chester Road, Rock Ferry, Birkenhead, Merseyside. L42 2AE. Tel: 051-645 3391.

Make sure you never miss an issue of Practical Electronics by placing a regular order with your newsagent. To help him obtain it for you, fill in and give him this form.

Please reserve a copy of Practical Electronics for:

Name

Address

.....

Town

Post Code

Practical Electronics (ISSN 0032-6372) is on sale from the first Thursday of each month and is published by Intra Press.

The distributor for Practical Electronics is:

**Seymour Press
Windsor House
1270 London Road
Norbury
London SW16 4DH**

General Specification

Display	
readout	8 digit, 7 segment, 0.5" LEDs, automatic DP indication.
Units	5 LEDs indicating s, μ s, kHz, Hz, MHz
Overflow	LED indicated reading out of range

Power requirements

Mains operation only – 240V RMS, 50Hz, 20VA

Internal Timebase

10MHz crystal oscillator or 10MHz DIL oscillator module (optional)

Crystal oscillator

Stability ± 80 ppm (this is the degree to which the frequency of the oscillator may be adjusted to correspond with a reference, also known as calibration)

Temperature stability dependent on crystal type, typical values are ± 50 ppm over -10°C to $+60^{\circ}\text{C}$

Supply voltage stability < 1.5 ppm for 10% supply variation

Aging dependent on crystal type, typically ± 10 ppm/year

External timebase

Frequency = 10MHz, input at rear BNC connector, automatically overrides internal timebase
Signal requirement is 50% duty cycle, HCMOS logic level

Input impedance = $1\text{M}\Omega/20\text{pF}$

Input protection: 50mA quick blow fuse

Instrument temperature range

0 to $+40^{\circ}\text{C}$

Dimensions

Width = 432mm height = 169mm
depth = 228mm

Weight

4.25kg

Rear panel facilities

Power connector, external timebase input, mains fuse holder (250mA antisurge – no other type should be used).

Table 3.

Chronos can be made to operate in just the same way, albeit much more precisely.

In stopwatch mode, as soon as the event begins, time starts accumulating on the display which continues counting up until the event finishes. However, the start of

the next event does not wipe the reading clear. Instead it continues the count from where the previous event finished. As with other extended time functions, the selected range determines the maximum time span and the measurement resolution and all readings are displayed in seconds.

Additional Features

Apart from the 16 main functions already mentioned, there are several additional functions and controls which extend the scope and versatility of the instrument – listed in table 2.

Like the high resolution frequency mode described earlier, Trigger Delay is also an auxiliary function which can be switched in as an adjunct to the selected function. However, it can be brought into play with any function (although it has no effect on function 3) and is used as a kind of digital filter to remove the effects of noise, interference and false triggering.

To a large extent, the input conditioning circuits can be used to clean up most noisy, distorted input signals. However, there are certain cases where even the most sophisticated input circuits can't cope so it becomes necessary to make use of more powerful techniques, such as trigger delay. (This feature is found on many top flight UCTs such as the Philips PM6652, but it is often called trigger hold off, or just hold off).

The most serious problems arise when making measurements on signals output from switch contacts or relay contacts which are beset with a phenomenon known as contact bounce. What happens is that instead of opening and closing cleanly, the contacts (particularly if worn or dirty) actually bounce back and forth for a while causing contact interruptions.

Bounce is a problem not only because it reduces the electrical life of the switch or relay contacts, but also because each of the many contact interruptions causes electronic equipment such as a UCT to mistrigger, tens, hundreds, or even thousands of times during the contact bounce time. Consequently, what should have been recorded as just one opening or closing of the contact may, in fact, register as

hundreds.

Trigger delay provides a way out of this problem. As soon as the counter has triggered, trigger delay prevents the counter from triggering erroneously on any of the unwanted bounce pulses for a time period called the delay time. Provided the delay time is longer than the bounce time, none of the bounce pulses can cause mistriggering.

Useful Feedback

Also shown in Table 2 are trigger outputs. These signals are buffered replicas of the digital signals output from the trigger delay section to the remaining processing circuits in the UCT. In other words, these outputs allow us to look at the input signals after they have been filtered, amplified, shaped and processed by the input circuits and the trigger delay circuits.

The trigger outputs are very important forms of feedback which allow the effects on the input signal to be seen as the various input conditioning controls are changed. Without these and other forms of feedback, it can be extremely difficult to perceive how the input signal is changed as it passes through the input and trigger delay circuitry.

Capture

The one shot function is another auxiliary feature activated by a front panel pushbutton. Although it can be brought into operation with any function, it is only really useful with functions 4 to 15. As the name suggests, one shot is used to measure just one of many events. It operates very simply and once activated, it causes the next measurement to be held on the display – any successive events at the inputs have no effect and are not displayed.

Selective Gating

Next on the list of special features is the A gated via B function. What this means is that the signal at channel A will be counted only when the signal at input B is at the correct level. In other words, all triggering of channel A is put under direct control of the signal at input B.

Hold and Reset

No counter worth its salt is complete without hold and reset functions, and the Chronos features both of them in two forms – either pushbutton activated, or operated by an external signal.

The hold pushbutton operates an electronic latch, with the first press this activates hold, the second press releases hold. This allows the operator to take his or her hands from the instrument while the reading is written down.

The reset facility does not require latching operation. One press of the button resets all the internal counters and latches and resets the display to its zero condition. The Chronos will remain reset until an incoming signal starts a new measurement.

Note that the Chronos is automatically reset when it is switched on with the display being cleared to zeros ready for the first measurement to begin – function 1 and range 1 are automatically selected.

As mentioned above, both hold and reset can be operated by external signals applied to the hold

and reset BNC inputs on the front panel. The inputs are active low, such that a simple switch connected to the inputs can be used for remote control of the hold and reset functions if the user is making measurements at a point some distant from the unit.

Alternatively, hold and reset can be controlled via logic signals applied to the same inputs (they are TTL/CMOS compatible, and have an input impedance of about 800k). Both inputs feature overload protection up to 250V RMS at 50Hz, so don't worry too much about the chance of damaging them.

Damaged Segments

The last control mentioned in table 2 is display test. Current seven segment displays are highly reliable devices, but should a segment malfunction the effect might not be obvious and can lead to erroneous results.

To guard against this, the display test function switches on all segments including the overflow LED at the press of a button.

The Chronos displays its results on eight, seven segment LED

displays with 1/2 inch high digits, and indicates the relevant units by illuminating one of the five LEDs alongside the display.

When the display reads 99999999, the next count will obviously cause it to overflow. This occurrence is indicated by an overflow LED which leaves us in no doubt that the reading is out of range.

Note that the UCT also features a gate LED. This is a form of feedback since it provides information about the counter's measurement circuits. When illuminated, either a measurement is taking place, or that the Chronos is ready and waiting for the next measurement to begin.

The timebase used within the UCT is, perhaps, the single most important part of the instrument, since it determines the accuracy and stability of all measurements. Because of this two different types are available plus provision for an external one.

Next month's article will look at the brains of the system, the 7226 universal counter chip. Also covered will be the conditions imposed on the signals before they are fed into the system. ■

Subscribe to Practical Electronics

Set your sights on technology with

- ⊕ Great Projects – like the PC EEPROM Programmer, or the Box that Bites portable burglar alarm
- ⊕ Innovations – the latest chips and gadgets, and a world electronics round-up
- ⊕ How It Works – explodes important electronic hardware
- ⊕ Data Sheet – full pin-outs and technical stats on a major chip
- ⊕ Techniques – expert answers to your technical problems

To order a 12-month subscription and get a free gift, fill in and return this form (or a photocopy) to:

Practical Electronics Subscriptions
Intra House
193 Uxbridge Road
London W12 9RA

UK Readers

One Year Subscription at £18.....
 BAEC/Educational Rate £16.20

Overseas Readers

Surface Mail at £22.....
 BAEC/Educational Concession Rate £19.80

Air Mail at £39.....
 BAEC/Educational Concession Rate

I enclose proof of BAEC membership

I enclose proof of Educational status (e.g. Headed paper)a

I wish to start/renew my subscription from theissue.

As my free gift I would like to receive (tick one)

The Practical Electronics Binder

The Transistor Equivalents Guide.....

Please send my monthly copy of PE to:

Name

Address

Town.....

Post Code

I enclose a cheque/postal order for

Or: Please charge my VISA/MasterCard
 Number

Expiry date

Signature (for credit card orders).....

(N.B. Cheques/Postal Orders or Banker's Drafts must be made out in £ Sterling, payable to Intra Press.)

EPROM PROGRAMMERS

MODEL 200 – £295 (other models from £195)

- Includes MSDOS driver software, serial cable, comprehensive manual, 32 pin ZIF socket and universal object file editor/converter.
- Programs virtually all EPROM devices currently available including micro-controllers (nearly 600!).
- Emulation capability with our E512 or the Greenwich Instrument emulators.
- Easy to set up – *not* a plug in board.
- 12 Month Guarantee. Money back if not completely satisfied.
- Designed, manufactured and supported in the UK.



Z8 ADAPTER FOR MODEL 200
 ● Programs Zilog and SGS parts
 ● All Security Functions Programmable £75
 Increasingly popular 8 bit microcomputer available in CMOS versions.

PIC 16C5x ADAPTER FOR MODEL 200
 ● Available for DIL or SOIC parts
 ● Manufacturer approved algorithms From £75
 The 16C54/7 is a range of low cost, low power, high speed microcontrollers ideally suited to low or high volume developments

8 PIN SERIAL EEPROM ADAPTER FOR MODEL 200
 ● Reads & programs over 50 devices
 ● 1°C (M8571, X2402), 9306, 2506 etc. £95
 As used for security devices in many car radios, mobile radios, cellular phones & security systems.

Adapters available also include
 ● 8748/41 family £75
 ● 8751 family £75
 ● 40 pin EPROMs up to 4 Mbit £75
 ● 63701/5 from £75
 ● 32 pin PLCC EPROMs £85
 ● 647180 £125
 Other families in development – please enquire.

We also sell Bipolar and Gang Programmers, EPROM Emulators and Erasers and a universal cross-assembler for IBM PCs and compatibles.

Write or phone today for Free Information Pack
 Tel: (0666) 825146 Fax: (0666) 825141



MQP ELECTRONICS, PARK ROAD CENTRE, MALMESBURY, WILTSHIRE, SN16 0BX UK

Scandinavian customers please contact:
 Digitron A/S, Alesund, Norway
 Phone 071-45 890 Fax 071-45 453

German customers please contact:
 Syntaron, Grasbrunn B. München, Germany
 Phone 089/4602071 Fax 089/4605661



VARIABLE VOLTAGE TRANSFORMERS

INPUT 220/240V AC 50/60	OUTPUT 0-260V	Price	P&P
0.5KVA 2.5 amp max	£29.00	£3.75	(£37.65 inc VAT)
1KVA 5 amp max	£37.40	£4.25	(£47.90 inc VAT)
2KVA 10 amp max	£54.00	£5.48	(£68.40 inc VAT)
3KVA 15 amp max	£71.50	£6.24	(£89.40 inc VAT)
5KVA 25 amp max	£126.50		(Carriage on request)

VOLTAGE CHANGING TRANSFORMER

1250 Watt auto. Tapped 0-90V, 100, 110, 115, 120, twice to obtain voltages between 90 and 240V. Fitted in heavy duty louvered metal case. Fused input. Price incl VAT & p&p £39.50.

COMPREHENSIVE RANGE OF TRANSFORMERS-LT-ISOLATION & AUTO 1110-240V Auto transfer either cased with American socket and mains lead or open frame type. Available for immediate delivery.

ULTRA VIOLET BLACK LIGHT FLUORESCENT TUBES
 4ft 40 watt £10.44 (£12.00 inc VAT) Caller only
 2ft 20 watt £7.44 + £1.25 p&p (£9.99 inc VAT)
 13in 10 watt £5.80 + 75p p&p (£6.53 inc VAT)
 12in 8 watt £4.80 + 75p p&p (£5.38 inc VAT)
 9in 6 watt £3.96 + 50p p&p (£4.52 inc VAT)
 6in 4 watt £3.96 + 50p p&p (£4.52 inc VAT)
230V AC BALLAST KIT for either 6in, 9in or 12in tubes. £5.50 + 55p p&p (£6.36 inc VAT)
 For 13in tubes £6.00 + 75p p&p (£7.75 inc VAT)

400 WATT UV LAMP
 Only £34.00 + £2.50 p&p (£41.98 inc VAT)
175 WATT SELF BALLASTED BLACK LIGHT MERCURY BULBS Available with BC or ES fitting. Price incl VAT & p&p £19.84.

12 VOLT BILGE PUMPS

Buy direct from the importers
 500 GPH 15h head 3 amp £16.00 inc.
 1750 GPH 15h head 9 amp £20.18 + £2.00 p&p (£25.50 inc VAT)

EPROM ERASURE KIT

Build your own EPROM ERASURE for a fraction of the price of a made-up unit kit of parts less case includes 12in 8 watt 2537 Angst Tube Ballast unit pair of bi-pin leads neon indicator on/off switch safety microswitch and circuit £14.00 + £2.00 p&p (£16.40 inc VAT)

SUPER HY-LIGHT STROBE KIT
 Designed for Disco, Theatrical users etc.
 Approx 16 joules Adjustable speed £48.00 – £2.00 p&p (£57.50 inc VAT)
 Case and reflector £22.00 + £2.00 p&p (£27.60 inc VAT)
 SAE for further details including Hy-Light and industrial Strobe Kits.

WIDE RANGE OF XENON FLASH TUBES

Write/Phone your enquiries
EXTENSIVE RANGE OF DIFFERENT TYPES OF GEARED MOTORS AVAILABLE FROM STOCK
WASHING MACHINE WATER PUMP
 Brand new 240V AC fan cooled can be used for a variety of purposes. Inlets 1 1/2 in. Outlet 1 inch. Price including p&p and VAT – £10.95 or 2 for £20 including p&p and VAT.

12V DC 20 RPM REVERSIBLE MOTOR

Swiss precision built. Ideal for robotics. Size: length inc. shaft 90mm, Diameter front fixing 38mm square. Currently advertised by well known supplier at £27.00 plus p&p & VAT. Our Price £14.95 inc. p&p & VAT

GIANT BLOWER EXTRACTOR UNIT

Twin output centrifugal blower 1HP 240V AC motor. Output approx. 3800 c.f.m. Size: Length 100cm; Height 27cm; Depth 26cm; Fixing plate 106x33cm. Price £125 + VAT Ex warehouse.

TORIN CENTRIFUGAL BLOWER
 230V ac 2.800 RPM 0.3amp 130mm diameter impeller outlet 63 x 37mm overall size 195 x 160 x 150mm long
 Price £17.50 - £2.50 p&p (£23 inc. VAT)

SHADED POLE GEAR MOTORS
 In the following sizes:
 9 RPM 12 RPM 30 RPM 160 RPM 110V AC or 240V AC with capacitors (supplied). Price incl VAT & p&p £12.85

GEARED MOTORS
 including capacitor and transformer for 240V AC operation. Price incl VAT & p&p £23.00.

SOLID STATE EHT UNIT

Input 230 240V AC. Output approx 15KV. Producing 10mm spark Built-in 10 sec timer. Easily modified for 20 sec. 36 sec to continuous. Designed for boiler ignition. Dozens of uses in the field of physics and electronics, eg supplying neon or argon tubes etc. Price less case £8.50 + £1.00 p&p (£10.95 inc VAT) NMS

HEAVY DUTY MOTOR
 Croutz 115V/230V AC heavy duty 17PM motor Anticlockwise type 82/015. Size 68mm diameter x 55mm long. Shaft 6mm diameter x 20mm long. Price inc. VAT & p&p £18.40.

RHEOSTAT
 50W 2 ohm 5amp ceramic power rheostat. Price inc. VAT & p&p £10.35

MICROSWITCH
 Pye 15amp changeover lever microswitch, type S171. Brand new Price £5 for £6.90 inc VAT & p&p.
 NMS – NEW MANUF SURPLUS
 R&T – RECONDITIONED AND TESTED



Whether your requirement for surveillance equipment is amateur, professional or you are just fascinated by this unique area of electronics SUMA DESIGNS has a kit to fit the bill. We have been designing electronic surveillance equipment for over 12 years and you can be sure that all of our kits are very well tried, tested and proven and come complete with full instructions, circuit diagrams, assembly details and all high quality components including fibreglass PCB. Unless otherwise stated all transmitters are tuneable and can be received on an ordinary VHF FM radio.

UTX Ultra-miniature Room Transmitter. Smallest room transmitter kit in the world! Incredible 10mm x 20mm including mic. 3-12V operation. 500m range..... £15.95

MTX Micro-miniature Room Transmitter. Best-selling micro-miniature room transmitter. Just 17mm x 17mm including mic. 3-12V operation. 1000m range..... £12.95

STX High Performance Room Transmitter. High performance transmitter with a buffered output stage for greater stability and range. 22mm x 22mm including mic. 6-12V operation. 1500m range..... £14.95

VT500 High-Power Room Transmitter. Powerful 250mW output providing excellent range and performance. Size 20mm x 40mm. 9-12V operation. 3000m range..... £15.95

VXT Voice Activated Room Transmitter. Triggers only when sounds are detected. Very low standby current, variable sensitivity and delay with led indicator. Size 20mm x 67mm, 9V operation, 1000m range..... £18.95

QTX180 Crystal Controlled Room Transmitter. Narrow band FM transmitter for the ultimate in privacy. Operates on 180 MHz and requires the use of a scanner receiver or our QRX180 kit (see catalogue). Size 20mm x 67mm. 9V operation. 1000m range..... £39.95

SCRX Subcarrier Scrambled Room Transmitter. Scrambled output from this transmitter cannot be monitored without the SCDM decoder connected to receiver. Size 20mm x 67mm, 9V operation, 1000m range..... £21.95

SCDM Subcarrier Decoder Unit for SCRX. Connects to receiver earphone socket and provides decoded audio output to headphones. Size 32mm x 70mm. 9-12V operation..... £21.95

HVX400 Mains Powered Room Transmitter. Connects directly to 240V AC supply for long term monitoring. Size 30mm x 35mm. 500m range..... £18.95

ATR2 Micro Size Telephone Recording Interface. Connects between telephone line (anywhere) and cassette recorder. Switches tape automatically as phone is used. All conversations recorded. Size 16mm x 32mm. Powered from line..... £12.95

UTLX Ultra-Miniature Telephone Transmitter. Smallest telephone transmitter kit available. Incredible size of 10mm x 20mm! Connects to line (anywhere) and switches on and off with phone use. All conversations transmitted. Powered from line. 500m range..... £14.95

TLX700 Micro-Miniature Telephone Transmitter. Best-selling telephone transmitter. Being 20mm x 20mm it is easier to assemble than UTLX. Connects to line (anywhere) and switches on and off with phone use. All conversations transmitted. Powered from line. 1000m range..... £12.95

STLX High-Performance Telephone Transmitter. High power transmitter with buffered output stage providing excellent stability and performance. Connects to line (anywhere) and switches on and off with phone use. All conversations transmitted. Powered from line. 1500m range..... £15.95

TKX900 Signalling/Tracking Transmitter. Transmits a continuous stream of audio pulses with variable tone and rate. Ideal for signalling or tracking purposes. High power output giving range up to 3000m. Size 25mm x 63mm. 9V operation..... £21.95

CD600 Professional Bug Detector/Locator. Multicolour readout of signal strength with variable rate bleeper and variable sensitivity used to detect and locate hidden transmitters. Switch to AUDIO CONFIRM mode to distinguish between localised bug transmission and normal legitimate signals such as pagers, cellular, taxis etc. Size 70mm x 100mm. 9V operation..... £49.95

*** SPECIAL ***

DLTX/DLRX Radio Control Switch. Remote control anything around your home or garden, outside lights, alarms, paging system etc. System consists of a small VHF transmitter with digital encoder and receiver unit with decoder and relay output, momentary or alternate, 8-way di1 switches on both boards set your unique security code. TX size 45mm x 45mm, RX size 35mm x 90mm. Both 9V operation. Range up to 200m. Complete System (2 kits)£49.95
 Individual Transmitter DLTX£18.95
 Individual Receiver DLRX£36.95

A build-up service is available on all our kits if required.

UK customers please send cheques, POs or registered cash. Please add £1.50 per order for P&P. Goods despatched ASAP allowing for cheque clearance. Overseas customers send sterling bank draft and add £5.00 per order for shipment. Credit card orders welcomed on 0827 714476.

OUR LATEST CATALOGUE CONTAINING MANY MORE NEW SURVEILLANCE KITS NOW AVAILABLE. SEND TWO 22P STAMPS OR OVERSEAS SEND TWO IRCs.

SUMA DESIGNS

The Workshops
 95 Main Road, Baxterley,
 Nr. Atherstone, Warwickshire CV9 2LE



Tel: 0827 714476

SERVICE TRADING CO

57 BRIDGMAN ROAD, CHISWICK, LONDON W4 5BB
 081-995 1560
 ACCOUNT CUSTOMERS MIN. ORDER £10



Showroom open Monday/Friday



An ample Parking Space

Micro-controllers: A Buyer's Guide

In dedicated logic dead? Peter Fasoli looks through the data sheets and comes across some interesting features which show that this may be the case.

Microprocessors have changed quite a lot since they were developed in 1969. Originally quite a few support chips were required for a system to be made operational. As designs got better and the density of transistors on chips increased, the capabilities improved and microprocessors diverged into a number of areas. High performance microprocessors such as the 68000 and the 80X86 series form one strand of development and single chip microprocessors or micro-controllers another. These take the

form of a computer-on-a-chip and have all of the control, memory, processing and I/O circuitry in a single package. The first of these was the Texas TMS1000 which had a pre-programmed ROM built in and was used in a variety of applications from musical doorbells to toys.

In general, microcontroller architectures are the same as the more mainstream microprocessor systems such as 6502, 68000, Z80 and so on. The main blocks are shown in Fig. 1. As well as the central processing unit there is

ROM to hold the program, RAM for data, an I/O port to get data into and out of the system and all of the decoding logic needed to control the various functions. Many controllers also have built in timers and serial ports. For development purposes, manufacturers offer versions of their chips with EPROM (Erasable Programmable Read Only Memory) rather than ROM so that the controlling programs can be tested and changed without having to throw the chip away and start again.

Packaged in standard 40 pin DIL (Dual In Line) cases, the EPROM versions or micro-controllers are usually made from ceramic material with a small window on top to allow the UV (Ultra Violet) light to get in to erase the EPROM. There are around 62000 transistors on the more basic chips – this compares with 172000 in the Intel 80286 microprocessor used in PC/AT compatible computers. The power consumption is usually about 40mA and some provide power down modes that reduce this to 10µA – an important facility in projects where power is only available from batteries.

I Got The Power

One of the main uses for micro-controllers is to replace complex logic systems. There are times when, although it may be possible to construct a chunk of synchronous logic to perform a specific function, it is cheaper, quicker and easier to use a microcontroller – even though using this may seem like building a nuclear power station specifically to run a 40W light bulb.

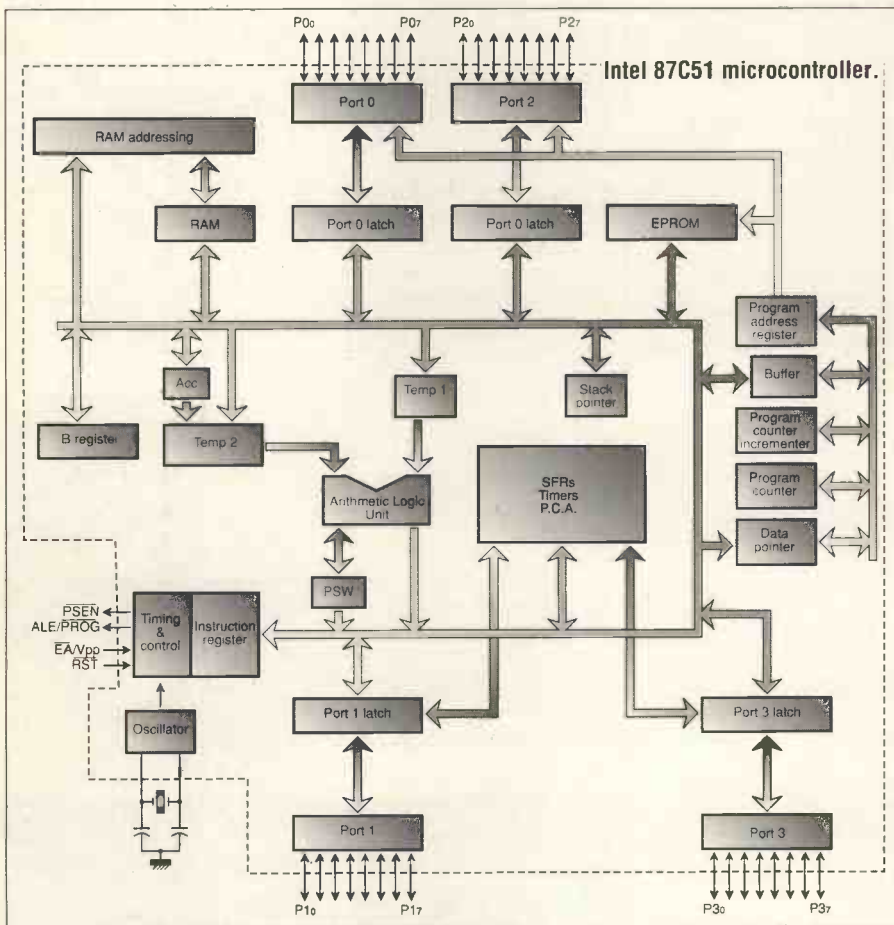

Micro-controllers fall into two main categories, one time programmable (OTP) and EPROM. The first has its ROM defined by the manufacturer and once set up, can't be changed - it is possible to get a manufacturer to blow a ROM to any pattern, it's just a matter of paying for it. The EPROM types can be re-programmed over and over but are usually about four times the cost of OTP versions. They can normally be blown in standard programming units and if they don't fit, special adaptors can be used. Many manufacturers supply support software in the form of emulators, assemblers and languages which run on main stream machine such as IBM PC compatibles. These allow software to be written and tested before downloading it into the EPROMs for on-board use. Some micro-controllers offer protection in the form of security bits. Once these are set, the only way to look at the software is to erase them. Unfortunately, this also erases the rest of the memory.

As far as processing power is concerned, micro-controllers are available in anything from four to 32 bits, the most common being eight bits. They all have I/O lines, with some having as many as 56. Other unusual features found in the top of the range systems are phase locked loops, dual CPUs, RGB video drivers, DMA systems, and serial communications controllers for speeds up to 2.5Mbits/s.

Quick Roundup

One of the most widely used range of micro-controllers is produced by Intel. The commonest are the 8748H and 8749H which offer a good selection of functions and have EPROM sizes of one or two kilo bytes. The rest of the range can have program areas up to 32k allowing

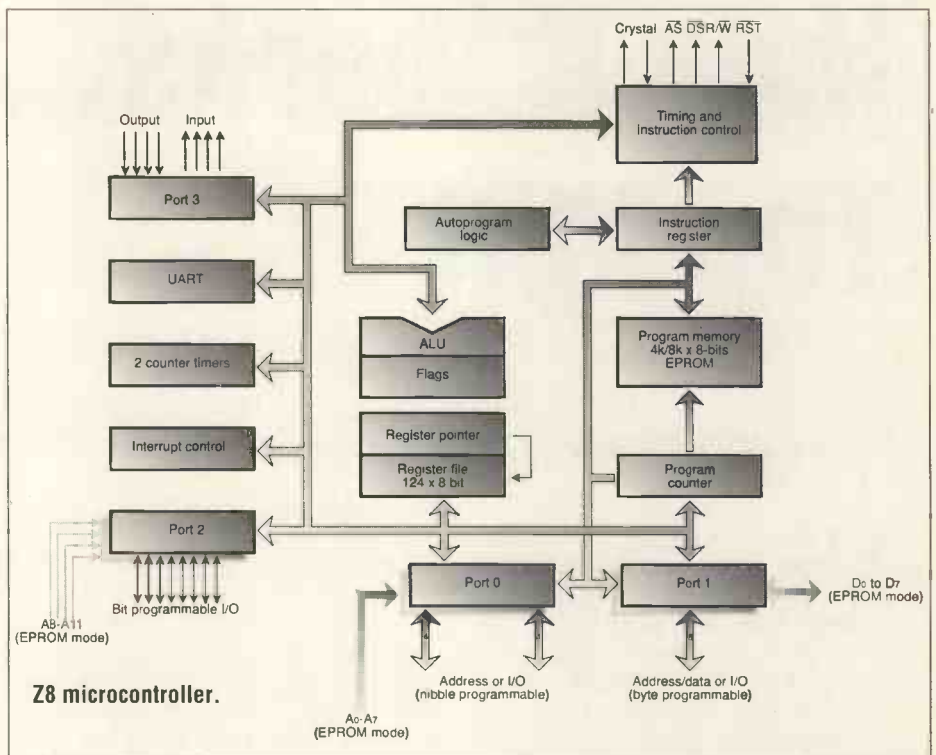

Z8 microcontroller.

more complex programs and data to be stored. The top of the range MCS-51 is manufactured using Intel's advanced HMOS technology and has a user configurable n-bit counter, adders and magnitude comparators.

Another range of micro-controllers that might be of interest to constructors is from SGS Thomson. The Z8 series (second source of Zilog) has a 144 eight-bit internal registers, 2k, 4k or 8k bytes of EPROM, 32 lines of programmable I/O, 47 instruction types with six addressing modes with ability to operate on four-bit BCD, eight-bit bytes and 16-bit words. By making use of the Z-bus they can be interfaced to external chips, such as additional I/O controllers and memory, allowing a wide range of systems to be implemented. Also available is an in circuit emulator which connects via an RS232 link to PC/XT/AT

compatible computers. Prices for EPROM versions of the Z8 are in the region of £15.

The TMS77C82 from Texas Instruments is a more expensive device (around £40 for the EPROM version) that provides a large number of functions. It has 62 instructions split into eight areas and can be programmed just like a standard 2764 EPROM with an adaptor.

The MELPS 740 series from Mitsubishi comes in 64-pin packages offering up to 56 I/O lines. Their architecture is pretty standard as is a range from Toshiba which is compatible with the Z80. The TMPZ84C810AF-6/AF has a Z80 CPU, SIO, CTC, DMA and all the other devices associated with a Z80 system, all in one 100-pin package.

Probably the top of the range in micro-controllers is the ST series from SGS Thomson. These operate at speeds up to 24MHz, offer 14 addressing modes and can access up to 16Mbytes of memory. They have up to nine parallel eight-bit I/O ports and 16/32-bit instruction sets. They also offer on-chip fuses, hardware address scrambling, memory access control and physical hardware detectors.

There are lots of micro-controllers available and although they offer a wide range of options and facilities, price is usually the limiting factor. ■

Some of the more common chips

Make	Device	ROM	RAM	I/O	Timers	Serial Port
Intel	8744	4k	256	32	2	Yes
Intel	8748H	1k	64	27	1	Yes
Intel	8749H	2k	128	27	1	Yes
Intel	87C51FA	8k	256	32	3	Yes
Intel	87C51FB	16k	256	32	3	Yes
Intel	87C51FC	32k	256	32	3	Yes
Intel	8752BH	8k	256	32	3	Yes
Intel	8798	8k	232	32		No
SGS	Z86E11	4k	128	32	1	Yes
SGS	Z86E21	8k	240	32	2	Yes
Texas	TMS77C82	8k	256	32	3	Yes

How It Works...

The VCR

Now almost as common as the TV set, the video cassette recorder is not a major form of home entertainment. PE takes the covers off and peeks inside.

Video Cassette Recorders (VCR) are now almost as common as TV sets in most homes. Introduced in the early 70s, a number of machines were available with Betamax, VHS, V2000 among others vying to set the standard for what was to become a major fad of the 80s. Eventually, only two formats were real contenders, Betamax and its strange stacked reels and, the eventual winner, VHS.

Helical Scanning

The step from recording sound on magnetic tape to doing the same with video signals is one of increased bandwidth. Early reel to reel machines used 1 inch wide tape and made the most of the available bandwidth by moving the tape past the record/playback head at high speed. Unfortunately, this type of transport mechanism meant that it had to be built to a fairly high specification.

Improvements in magnetic media technology and the use of helical scanning meant that far more data could be crammed into a smaller area. By spinning the record/playback head at high speed, the effective rate at which the data could be stored or retrieved was increased. Aligning the head at an angle to the tape layed down the information as a series of slanted tracks. This allowed the cassette tape to be narrower and move at reduced speed giving rise to the modern video cassette recorder.

On time

Early VCRs were playback only but by building in a full colour TV tuner, programmes could be recorded from the air while another channel was being viewed on a normal TV. The inclusion of a timer meant that recordings could be made and viewed at a later date. Early timers only switched the tape

on at a certain time, leaving the VCR running until the tape finished. The latest machines allow a large number of on/off programmed times to be set so that viewers can go on holiday and not miss a single episode of Neighbours.

In The Machine

When they are out of the machine, VHS cassettes have their reels locked and cover the tape up with a flap. Once in the machine the reels become unlocked and the tape guard lifts up to expose the tape. Pressing the play or record buttons cause the tape loading rollers to pull a length of tape from the cassette and wrap it around the spinning head. The transport then transfers it from the feed reel to the take up reel and information is transferred to or from the tape. Audio information is transferred via a static head which puts information on a separate track to the video signal – this is one of the reasons why an option to record sound separately is generally available.

The Future

The modern VCR has not really changed since it was first introduced. Minor improvements have been the introduction of stereo and half speed transport systems that double the capacity of standard length tapes – at a slight reduction in quality. The VCR looks set to run for quite a while yet, the only possible contender for its prime position may be erasable optical discs when they become available in large quantities. ■

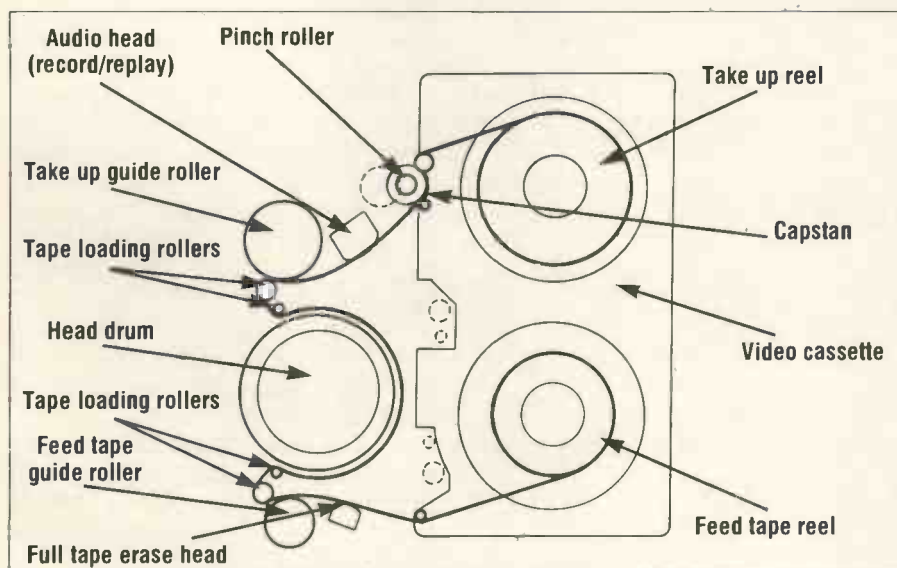

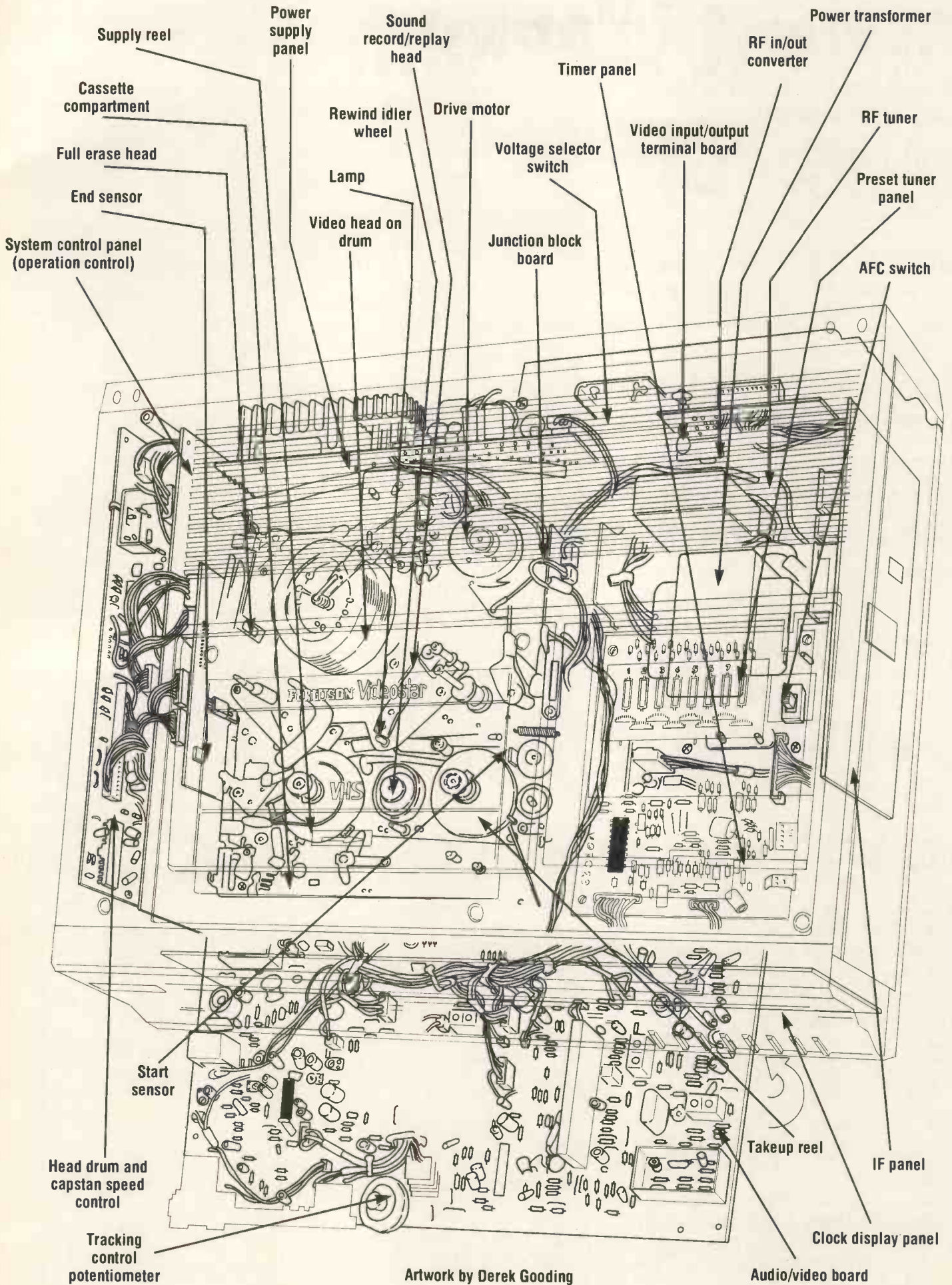

Artwork by Derek Gooding

Rewarding Loyalty

You can be a winner with our Reader Loyalty Bonus.

This month's top ten readers:

J. Hewitt of Wimbledon has £115.00 refunded for trading with Number One Systems.

Antony Kidd of Aberdeenshire receives £90.95 for buying goods from Maplin Electronics.

P Doherty of Brighton who bought £84.49 worth of goods from B.K. Electronics.

Ben Willcox of Scarborough has the £74.65 he spent with Maplin refunded.

Paul Vickery of Tiverton, Devon traded with Maplin Electronics and has £70.49 refunded.

A. Anderson of Crewe gets back the £56.17 he spent with Cirkit.

C.W. Workman of Cheltenham claims his £33.99 which he spent with B.K. Electronics.

J. Smith of London N6 secures his £24.95 for purchasing goods from Keytronics.

Leon Volawek from Pontypridd is reimbursed £18.95 for trading with Maplin Electronics.

B. Patel of Bradford has £12.95 repaid for his purchase from Henry's.

See page 30 for entry details!



FREE

CRICKLEWOOD ELECTRONICS



90'S DECADE COMPONENT CATALOGUE

- ONE OF THE LARGEST RANGES OF COMPONENTS IN THE UK
- FAST AND EFFICIENT SAME DAY PERSONAL SERVICE
- VERY COMPETITIVE PRICE; QUANTITY DISCOUNTS AVAILABLE
- DISCOUNT VOUCHERS INCLUDED
- NO MINIMUM ORDER

CRICKLEWOOD SUPPLY MOST OF THE COMPONENTS FOR P.E. PROJECTS. 13,000 STOCKLINES (MANY UNOBTAINABLE ELSEWHERE) PLEASE PHONE US FOR YOUR SPECIFIC NEEDS.

FILL IN THE COUPON AND POST IT TO RECEIVE YOUR FREE CRICKLEWOOD ELECTRONICS CATALOGUE AND VOUCHERS WHICH YOU CAN USE AGAINST YOUR NEXT PURCHASE.

Cricklewood Electronics Ltd
40 CRICKLEWOOD BROADWAY, LONDON, NW2 3ET
Tel: 081-450 0995/452 0161
Fax: 081-208 1441 Telex: 914977

VISA

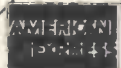

TELEPHONE ORDERS OUR SPECIALITY

**CRICKLEWOOD ELECTRONICS
COMPONENTS CATALOGUES**

PLEASE SEND.....COPIES OF THE
FREE CRICKLEWOOD ELECTRONICS
CATALOGUE TO:

NAME

ADDRESS

.....

.....

.....

Remittance enclosed £.....

PCBs for PE Projects

Practical Electronics' circuit boards make assembly much simpler. All our PCBs are fully drilled and roller tinned – just slot in and solder the components as shown in the project

Mail Order

Select the boards you want and send your order to:
PE PCB Service, Practical Electronics, Intra House, 193
Uxbridge Road, London W12 9RA
Prices include VAT, postage and packing. Add £2 per board for
overseas airmail.

Cheques should be made payable to Intra Press (payments by
Access and Visa also accepted). Quote the issue, project name
and PCB code number. Print your name and address in black
capitals. Please do not send any other correspondence with
your order.

Phone Order

Use your access or Visa card and phone 081 743 8888.

Although many boards are held in stock, occasionally they
must be re-ordered before despatch, so please allow 28 days
for delivery.

Older circuit boards may have been deleted from the
catalogue. Please check the latest issue of Practical Electronics
before ordering.

Photocopies of the original project text are available for £1.50
each (£2 overseas).

We do not carry components. Refer to our advertising pages
for suppliers.

DEC 89

VIDEO AGC STABILISER 199 £6.50
MINI METRONOME 201 £5.90

JAN 90

BARGRAPH TACHOMETER 202 £5.90
EEPROM PROGRAMMER (KEYBOARD VER) 203 £14.50

APR 90

PC/INTERFACE 209 £5.90

MAY 90

EPROM POLY-PROG (MAIN PCB) 210 £8.50

JUNE 90

EPROM POLY-PROG (TOP PCB) 211 £7.50
MESSAGE MAKER 212 £9.50
BAUD RATE CONVERTER 213 £4.90
INTERMITTENT WIPER 214 £3.90
CIRCUIT BREAKER 215 £4.90

JULY 90

MORSE DECODER 216 £9.50

AUG 90

VOLTAGE PROBE 218 £5.80
AF OCTAVE MEASURER:
FILTER DRIVE 219 £6.60
ANALOGUE FILTER 220 £7.35

SEP 90

AF OCTAVE MEASURER
AMPLIFIER 221 £7.35
SWITCHED FILTER 222 £7.35

SWITCHED FILTER DRIVE	223	£7.35
TELE-SCOPE – MAIN PCB	224	£11.50
OCT 90		
TELE-SCOPE – SIGNAL PCB	225	£4.90
TV INTERFACE	226	£4.90
CHIPTESTER	227	£11.50
NOV 90		
BIKE COMPUTER		
– MAINPCB	228	£9.50
– POWER SAVER	229	£4.90
DEC 90		
8748 PROGRAMMING ADAPTOR	230A/B	£6.50
FEB 91		
FROST ALARM	233	£5.50
DIGITAL COMPASS	234A/B/C	£16.50
SERIAL MULTIPLEXER	235	£6.50

OTHER BOARDS AVAILABLE IN SMALL NUMBERS

175, 178
181, 183
194, 197
204, 206, 208

THESE BOARDS ARE NOT BEING REPRINTED

Advertisers' Index

ADM Electronics	54
BK Electronics	57
Cambridge Computer Sci.	55
Coles Harding	54
CR Supply Company	55
Cricklewood Electronics	48
Electronics Shop	54
Fraser Electronics	54
Global Specialities	4
Greenbank Electronics	40
Hobbykit Electronics	21
J&N Bull Electrical	26
JJ Components	36
JPG Electronics	55
Keytronics	14
Labcenter	4
Laser Alarms	55
London Electronics College	54
Lys Electronics Components	36
Maplin	OBC
Marapet	55
Mauritron	56
MQP Electronics	43
NCT	60
NR Bardwell	55
Number One Systems	IBC
Omni Electronics	54
Panrix Electronics	4
Partridge Electronics	56
Radio & Telecom Corr. Sch.	54
Service Trading	43
Simpsons Manufacturing	55
Stewart of Reading	60
Suma Designs	43
Tandy	IFC
Tsien (UK)	9

When The Dream Comes True

John Brook on superconductors, from their origin at the beginning of the century to the latest discoveries using higher temperatures..

What began as an obscure phenomenon of the early part of the century has developed over the years to become one of the holy grails of modern physical electronics. Since they were discovered superconductors have promised many things from resistance free wiring and super power magnets, to ultra fast switching circuits and picoprocessors.

In The Beginning

The first hint that resistanceless conductors could be made was in 1911 when Kamerling-Onnes used liquid helium to study the behaviour of metals at low temperatures. He found that the electrical resistivity of pure mercury dropped to zero at around the boiling point of helium. Thinking this a new state of matter, the others being solid, liquid, gas and plasma, he dubbed it the superconducting state. The temperature at which resistance disappears he named the transition

temperature. Fig. 1 shows how the resistance of mercury drops to zero at just over 4.1K. The theoretical minimum temperature is -273.15°C and occurs when all molecular motion stops. A special temperature scale known as K or Kelvin (named after Lord Kelvin, an early pioneer of physics) is used to define absolute temperatures. Conversion to centigrade is simply a matter of subtracting 273.15 from the K value – unlike Fahrenheit, Kelvin and Centigrade have the same gradient so no other conversion factor is needed.

After a little more experimentation, it was soon discovered that other materials could become superconductors and that they had different transition temperatures – see table 1. However, the term superconductor does not necessarily mean perfect conductor, even though it offers no resistance to current flow under the right conditions. In 1933, W Messener (born 1882) discovered that superconductors had a feature not supported by theoretically perfect

conductors. Internally, the magnetic field is always zero., that is, they will not allow any magnetic flux to exist within them. Fig. 2 shows that a normal conductor, when placed in a magnetic field, allows the field to pass straight through. A superconductor, on the other hand, has a surface current that creates a magnetic field within the material just cancelling the external magnetic field. This is an important property of certain superconductors and puts limits on their practical use.

With The Flow

Current within a superconductor operates as with normal conductors, via electrons moving charge from one end of the conductor to the other. The lack of resistance and other effects is due to the indirect interaction of pairs of electrons via local elastic deformations of the metal crystal and was first explained by John Bardeen (of transistor fame), Leon Cooper and John Schrieffer in 1957. In normal conductors, the current flows through the material and encounters electrons which disperse randomly towards the electric field and get in the way causing resistance. In a superconductor the current is carried by electron pairs known as Cooper pairs which attract rather than repel each other due to their like charges. Their collective momentum carries them through the material at a fixed rate rather than the random rate of normal conduction. This means that the current is conducted without variation with the result that the resistivity appears to be zero.

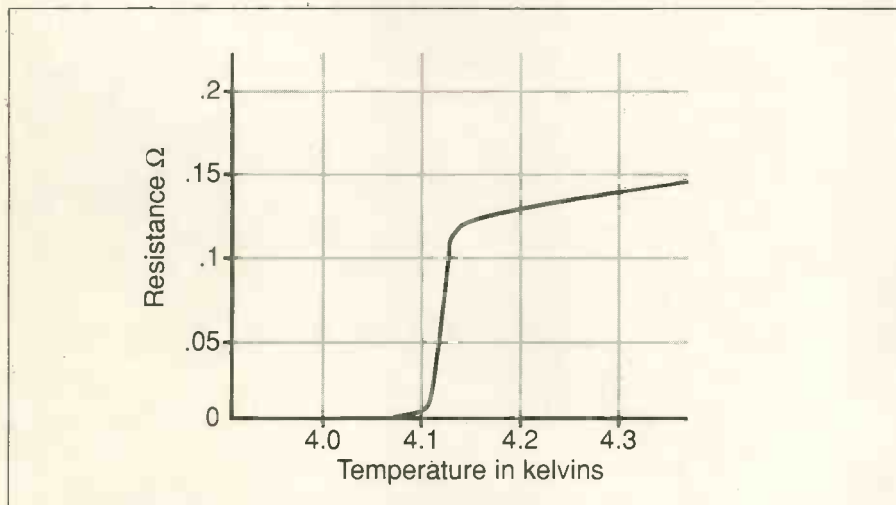

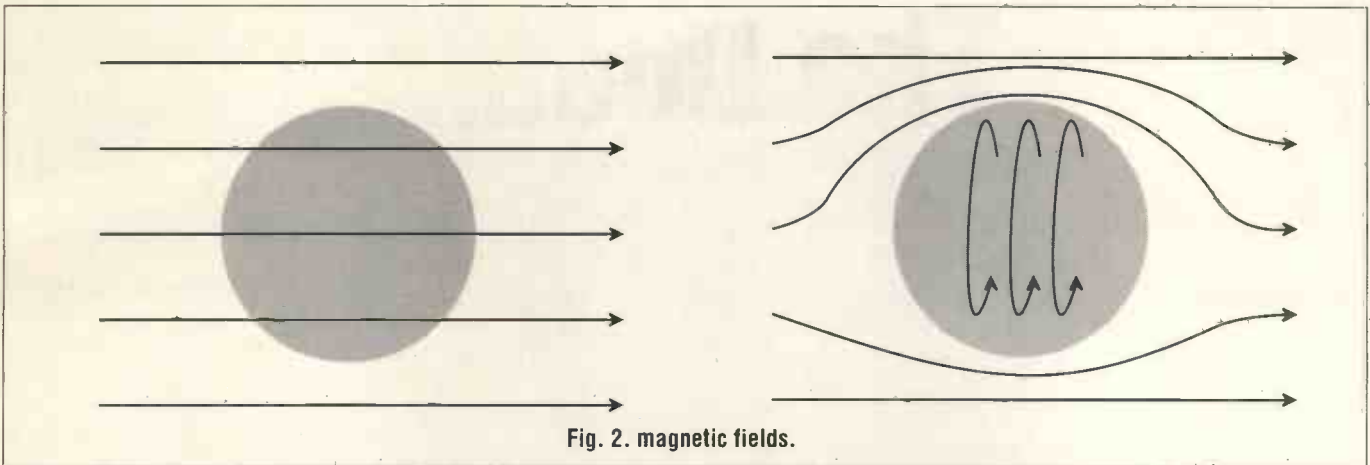

Fig. 2. magnetic fields.

As the current flow is increased the momentum of the electrons rises until a limit is reached where superconductivity is destroyed. This critical current also leads to a maximum magnetic field which prevents the material from being used to form large electromagnets. Fortunately, there are two types of superconductor, known as I and II. The first has just two states, superconducting and normal and suffers from magnetic field strength limitations. The second type has three states, superconducting, mixed and normal. In the mixed state a magnetic field passes through the material in the same way as a normal conductor but the lack of resistance is maintained. This allows it to be used to create high power magnetic fields (more than 10Wb/m²) for use in large electromagnets.

The Heat Is On

Early superconducting materials had to be cooled to the very low temperatures of liquid helium before they would work. However, by 1973 J R Gavaler in the USA made a compound of Nb₃Ge with a

Element	Critical temp (K)
Tungston	0.01
Cadmium	0.56
Aluminium	1.19
Mercury	4.15
Niobium	9.46
Technetium	7.92 to 8.22
ZrAl ₂	0.30
AuBe	2.64
NiBi	4.25
Nb ₃ Al	17.5
Nb ₃	18.05
Nb ₃ Al ₈ Ge ₂	20.05

Table 1. Example critical temperatures.

transition temperature of 22.3K which is above the boiling point of liquid hydrogen (20.45K). In 1986 a team of IBM scientists in Zurich was able to produce a superconductor that operated at 35K by using a compound of barium, lanthanum and copper oxide. This led, in 1987, to the production of a compound that included yttrium and copper oxide operating at 98K. In the last few years there have been reports of a superconductor operating at 294°K (an amazing 21°C or, roughly, room temperature) although they are unsubstantiated and have not yet been repeated. Even if this is not true, recent developments suggest that a reproducible room temperature superconductor should appear within the next ten years.

Applications

There are a number of ways in which superconductors can be used, one example is superconducting wire.

What is, perhaps, unusual about high temperature superconductors is that they are not very good normal electrical conductors. In practice, the compounds don't resemble metals at all, they are not malleable and cannot, easily, be made into wires. Because of their brittle nature, they have to be supported by filaments of other materials. One method that has been tried is to surround the superconductor with a sheath of copper. A single strand cable can be used in applications where the magnetic field level is quite low. For high field strengths, multiple core cables can be made up (see Fig. n). The big problem with modern superconducting cables is the need

for coolant. Because of the lack of resistance, once the current required for the magnetic field has been introduced into the windings, the power source can be removed. The only power required by the system is that needed to keep the magnets at low enough temperatures to maintain their superconducting nature.

The Future

In 1962 Brian Josephson working at Cambridge University came up with the idea of a very low temperature sandwich of superconductors separated by an insulator. He predicted that a small direct current would flow between

Absolute Zero

In 1662 Robert Boyle formulated a law which related the temperature, pressure and volume of a gas. It states that a given fixed mass of gas at a constant temperature has a volume which is inversely proportional to its pressure. Reducing the temperature and keeping the pressure constant reduces the volume. At -273.16°C (-459.69°F) this reaches zero and is defined as the absolute zero of temperature.

In low temperature physics, the use of kelvins, the unit of absolute temperature, has taken over from celsius or fahrenheit and is also known as the thermodynamic temperature scale. It is defined with respect to an idea reversible heat engine working on a Carnot cycle between two temperatures, T₁ and T₂. If Q₁ is the heat received at the higher temperature and Q₂ the heat lost at the lower temperature T₂, then T₁/T₂ is equal to Q₁/Q₂.

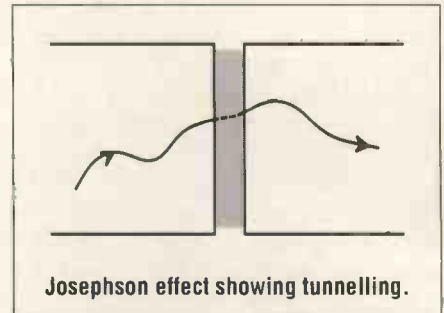
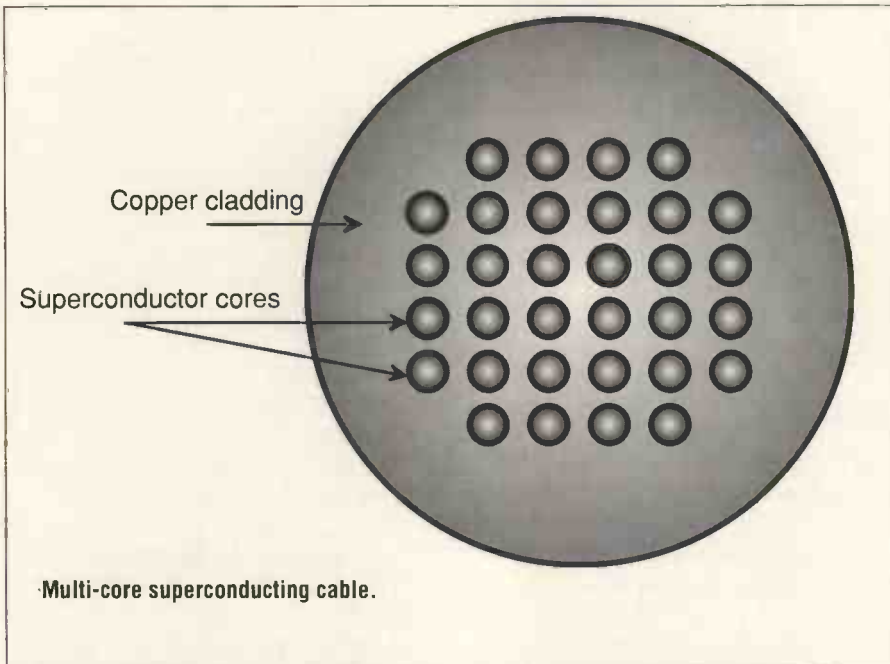

realign themselves with the field and release any energy they picked up. This can be detected and used to form an image that does not rely on harmful radiation such as X-rays.

Another use for Josephson junctions is as electronic switches since they can operate in a similar way to a transistor but at more than 100 times the speed. A microprocessor or, perhaps, picoprocessor based around the Josephson junction idea would be able to outperform current computer technology by a large factor.

High temperature superconductors may also find uses in magnetic bearings which take advantage of the fact that magnetic flux doesn't go through a superconductor. The design is simple and was first tried out in 1960. It consisted of a disk and a cylinder, but made from superconducting material. The disk floats on the magnetic flux and the spin is controlled via the spin of the cylinder. The main problem at the

the two superconductors even though there was no potential difference between them. This was verified in 1963 by Anderson and Rowell at Bell Telephone Labs as was the effect of a magnetic field on such a junction. The AC Josephson effect predicted that connecting a DC voltage across the junction would cause oscillating supercurrents which would produce or absorb electromagnetic radiation. If a monochromatic radiation source (say a laser) was applied to the junction, the Josephson oscillator would lock on to it. This effect makes the Josephson junction an ideal sensor

for EM radiation and magnetic fields and is known as a SQUID (Superconducting Quantum Interference Device).

A major use of a high temperature SQUIDs when they become available would be in nuclear magnetic resonance (NMR) scanners. These are used with other sensors to produce images of the interior of a patient. They work by generating a large magnetic field around the subject with a large electromagnet. The protons in the tissue molecules align themselves with the field and an injection of radio frequency excites them. As the RF burst decays, the protons

Cryogenics

The study of materials at low temperatures has been a branch of physics for many years. Early workers in the area were James Joule and William Thompson, who later became Lord Kelvin, first Baron. They explained the Joule-Thompson effect which states that the temperature falls when a gas is permitted to expand without any more energy coming in from the outside. This effect is used in modern fridges and freezers. Gases such as Freon (a fluoro-carbon) are compressed raising their temperatures and delivering heat to a radiator outside the fridge. From there the gases are pumped to an expansion valve inside the fridge where they are allowed to evaporate, a process which absorbs heat.

In 1895 James Dewar (the inventor of the vacuum flask) succeeded in

liquefying hydrogen using the Joule-Thompson effect and, in 1908, H K Onnes liquefied helium in the same way. Modern cryogenics (from the Greek kruos meaning frost) uses the Joule-Thompson effect plus a number of methods to get down to extremes of temperature. By placing the material to be studied in contact with liquefied gases such as hydrogen and helium which are then allowed to evaporate, temperatures down to around 4K are achieved. The minimum temperature that can be reached in this way is about 0.3K. To get lower than this paramagnetic cooling is used. Paramagnetism is the weak magnetisation of a material in the same direction as an applied magnetic field. The effect varies inversely with temperature and involves the partial

alignment of orbital electron dipoles. The material to be cooled is placed in contact with liquid helium and subjected to a strong magnetic field. Any heat generated is conducted away to the helium which, in turn, conducts it out of the cooling system. When this is stable, the helium is removed and the magnetic field reduced to zero. This cools the material to temperatures of around 10^{-2} K to 10^{-3} K. Unfortunately, heat leaks back into the system so achieving stability is very difficult. To cool material still further, a complicated process known as nuclear adiabatic demagnetisation is used. This brings the temperature down to record levels of around 2×10^{-7} K.

moment is the cost of cooling and production of suitable superconductors. The advent of high temperature superconductors may see this simple experiment become a reality.

Another use for high temperature superconductors is in alternating current transformers. Research in 1963 deduced that a 40% saving in size wight and cost could be achieved if high temperature superconductors were available to replace standard copper windings. Current systems would require too much cooling equipment to be effective so this possibility will have to wait until room temperature superconductors become a reality. ■

Bibliography

Superconductivity, Experimenting in a new technology by Dave Prochnow from Tab Books, ISBN 0-8306-3132-1

Physics of the atom by Wehr, Richards and Adair from Addison Wesley, ISBN 0-201-08584-4

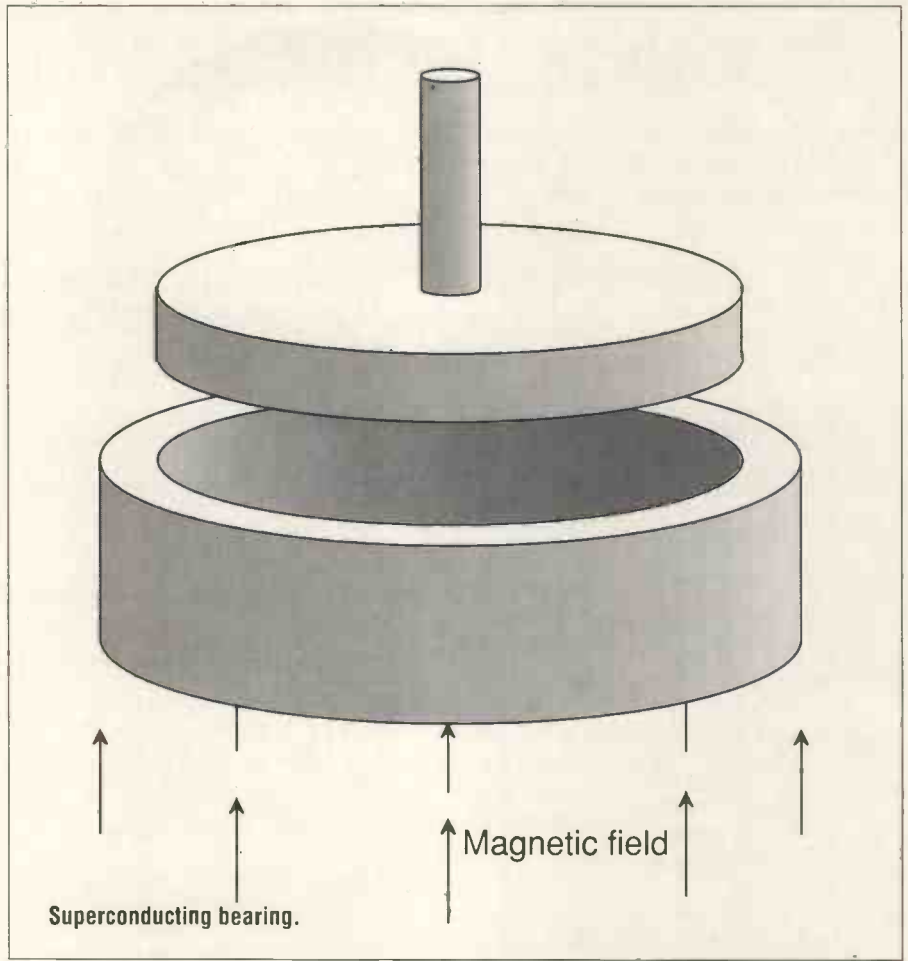

Dry Joints

Jan 91 LCD rev counter

The 4048 should be a 4068 8 i/p NAND

The IC numbering should have been IC2, IC3, IC1 in order left to right. Additionally, the tracks IC4

Pin 34 (Store) and Pin 33 (Reset) are transposed.

IC4 pin 31 is correctly tied to +5V. \ The notation should read \overline{INH} .

A further point has arisen, if erratic Store triggering occurs, connect the unused inverter IC1f in parallel with IC1b, cut the track connecting IC1 pin 3 to ground, then wire IC1 pin 3 to IC1 pin 9 and wire IC1 pin 4 to IC1 pin 8.

Thanks to Andrew Bowman

March 91 MIDI Analyser

The main circuit diagram slipped off the page, see below.

March 91 Car positioning aid

In Fig. 5 the line labelled To IC5 pin 14 should have gone to 14G and not 14F

Fig. 6 - There should have been cuts at 15C, 15D, 15E and 15F. There should be no cut at 26E and tracks G and H should be connected together in column 25.

Fig. 7 - There should have been cuts at 22L, 22N, 22O, 22Q, 22S and 24P and links from 20A to 20B, 15H to 15J, 35P to 35S

Thanks to Mr. Allen of Wolverhampton.

Frequency Master March 91

Page 22 - col 3 Fig 7 should read Fig. 4

Page 24 - Fig. 4 should actually have been Fig. 5

Page 25, components list - R1 2470k should read R12 470k, VR1-VR 210k should read VR1, VR2 10k

Eprom Programmer April 91

Page 21 - Fig. 11 disappeared. However, since all it showed was the pin outs of various memories, it wasn't all that vital. ■

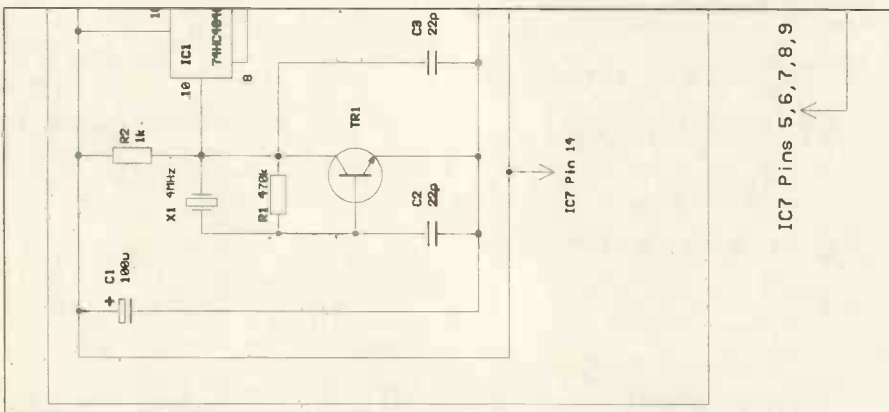

Practical Electronics Classified Ads

Reach thousands of serious electronic and computer enthusiasts - advertise in PE Classified pages:
 Rates 20p (plus 3p VAT) per word or £8.50 (plus £1.28 VAT) per column cm. All classified advertisements must be pre-paid. Send your copy, with remittance payable to Intra Press, (Payment by Visa or Access accepted - ads may be phoned in) to:

**Practical Electronics, Intra House, 193 Uxbridge Road, London W12 9RA.
 Tel: 081-743-8888. Fax: 081-743-3062**

Education

FULL-TIME TRAINING COURSES

2 YEAR

BTEC NATIONAL DIPLOMA

Electronics and Communications Engineering

(TV, Computers, Programming, IT)

1 YEAR

BTEC NATIONAL CERTIFICATE

1. Electronic Equipment Servicing

(TV, Video, CCTV)

2. Computing Technology

(Microprocessors, DataComms, Interfacing)

3. Information Technology

(Telecomms, Satellite TV, Networks)

4. Software Engineering

(Assembler, BASIC, Pascal, CAD/CAM)

★ Those eligible can apply for E.T. grant support ★

★ An equal opportunities programme ★

COURSES COMMENCE

Monday 22nd April 1991

LONDON ELECTRONICS COLLEGE

Dept: AA, 20 Penywern Road,
 London SW5 9SU. Tel: 071-373 8721

Start training now for the following courses.

- Telecomms Tech C&G 271
- Radio Amateur Licence C&G
- Microprocessor
- Introduction to Television

Send for our brochure - without obligation or telephone us on 06267 79398 (Ref: PE5/91)

Name.....

.....

.....

Radio & Telecommunications Correspondence School,
 12 Moor View Drive, Teignmouth,
 Devon TQ14 9UN

Retailers

EDINBURGH

OMNI

stock a wide range of electronic components at
**174 Dalkeith Road
 Edinburgh EH16 5DX**

Tel: 031 667 2611

Open Mon-Fri 9am-6pm
 Sat. 9am-5am

NEW CATALOGUE OUT NOW

Price is just £1.50

Contact Omni Electronics now for details

LONDON N WEST

CRICKLEWOOD ELECTRONICS

One of the largest ranges of components in the UK!

40 Cricklewood Broadway,

LONDON NW2 3ET

Tel: 081-450 0995/452 0161

Project your retail image here!

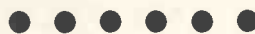

Phone David Bonner for details on
081-743-8888

Retailers

MANCHESTER

THE ELECTRONICS SHOP

We stock a large range of electronic components, test equipment, telephone accessories, computer accessories, microphones, speakers, discolorighting, mixers, meters, stylus, so call in and have a look around.

29 Hanging Ditch, Manchester M4 3ES

Telephone: 061-834-1185

Fax: 061-833-2969

SOUTHSEA

ELECTRONIC COMPONENTS

EVERYTHING FOR YOUR NEXT PROJECT

THE BIGGEST DISPLAY IN THE SOUTH IS AT

FRASER ELECTRONICS

42 ELM GROVE ★ SOUTHSEA ★ HANTS

Telephone: 0705-815584



Surplus

SURPLUS/REDUNDANT ELECTRONICS COMPONENTS WANTED

ICs - Tuners - Transistors - Valves - Diodes etc - any quantity considered - immediate payment.

ADM ELECTRONICS SUPPLIES

Tel 0827 873311

Fax: 0827 874835

TURN YOUR SURPLUS

ICs transistors etc into cash, immediate settlement. WE welcome the opportunity to quote for complete factory clearance.

Contact:

COLES-HARDING & CO.,

103 South Brink, Wisbech, Cambs.

ESTABLISHED 15 YEARS

Tel: 0945 584188 - Fax: 0945 588844

Modernising your workshop?
 Sell your old equipment through PE Classifieds pages.

Surveillance

Kits, Plans, Assembled Units, Surveillance Microtransmitters, Phone Recording Switches, Trackers, Defence /Protection Circuits, Plus much more. Send 2 x 22p stamps for lists, or tel. 05436 76477 24hrs. Everything for the budding 007. ACE(PE). 53 Woodland Way, Burntwood, Staffs. WS7 8UP.

Miscellaneous

encoders etc. Contact Trustford Electronics. Tel: 0924-455853 (24 hrs.) Collectors. MARCONIPHONE A2 Twin Valve Instrument Number 3628. BBC Decal. Serious enquiries 0803 867473 Circuit Diagram and Instructions for a 25 Watt FM Broadcast Transmitter. Cheques/POs £3.50 to AM Enterprises, 44 Altyre Way, Beckenham, Kent BR3 3HA
FREE!!!! FREE!!! FREE!!!
 EIGHT MICROTRANSMITTER PLANS (WORTH

Miscellaneous

FOR SALE
 Practical Electronics in Binders volumes one (1965) to ten (1974) and later loose copies. Offers for lot (0905) 54318.

Miscellaneous

DO YOU USE TELEPHONE LINES?

CONNECT YOUR EQUIPMENT TO THE TELEPHONE SYSTEM without the cost and delay of type approval.

ACHIEVE THIS BY USING OUR Approved transmit, receive and hybrid systems for use on P.S.N. (normal dialling system), Private circuits, or Music Programme circuits.

THE LEGAL ECONOMICAL SOLUTION for broadcasting signals – Security alarm signalling – linking of remote factory sites for P.A. – intercom etc.

Call 0268 793381 or Fax 0268 565759 FOR FULL DETAILS

PARTRIDGE ELECTRONICS
 A.C. PARTRIDGE LTD.

UNIT D
 318 HIGH ROAD
 BENFLEET
 ESSEX SS7 5HB

SERVICE MANUALS

Available for most equipment. TVs, Videos, Test, Amateur Radio etc. Write or phone for quote.
Mauritron (PE), 8 Cherry Tree Road, Chinnor, Oxon OX9 4QY
Tel: (0844) 51694. Fax: (0844) 52554

FM Broadcast transmitting lynx, stereo

£3.95) PLUS THREE CATALOGUES OF PLANS/MANUALS COVERING SURVEILLANCE, COUNTERSURVEILLANCE, UNUSUAL SPECIALIST ELECTRONICS, LOCKSMITHING, "JAMES BOND" VEHICLE MODIFICATIONS, PYROTECHNICS, SECURITY, PROTECTION SYSTEMS, MONEY-MAKING, ELECTRIFICATION DEVICES, MICROTRANSMITTER KITS/UNITS PLUS MORE... FOR YOUR CATALOGUES/FREE PLANS, JUST SEND 5x17P STAMPS (P&P):-

SPECIALIST CONSULTANTS, PO Box 33, TORQUAY TQ2 7ES

WORKSHOP CLEARANCE.

Components, equipment, software, books. S.A.E. for lists. MEAKIN. West End Gardens, Fairford, Glos. GL7 4JB.

Oscilloscope double beam 10MHz. Portable (tequipment) £120, AVO 8 Mk5 cased £100, both excellent, geiger counter £50 wanted. Transistorized 20-60 MHz oscilloscope not working/"cheap!" 0803-882572.

GWBasic and dBase III+ (.PRG) files compiled to standalone .EXE progs. S.S.A.E. Williams R/O 56, Main Street, Mexborough, S. Yorks. S64 9DU.

Electronic components. Test gear and technical miscellany shop, free component catalogue sent on request. 75 Priory Road, Southampton. (0703) 584680.

Workshop Clearout. TO3 Heatsinks, 60x75x16mm, approx. 3.5oC/W.

Normal price £2.00, selling for 50p each. P&P £1 per order, orders over £15 deduct 10%. Orders to K.S.

Termie, 57 Rosemead Drive, Oadby, Leicester, LE2 5SD.

PE Loyalty Bonus brings results!

CLASSIFIED COUPON

									£3.29
									£4.94
									£6.58
									£8.23
									£9.87
									£11.52

Rates are 20p per word plus 3.5p VAT (lineage, for semi-display advertisements contact our Ad. Dept.). All classified advertisements must be pre-paid. Please send your copy with the remittance (payable to Intra Press or payments by Visa or Access accepted) to: Practical Electronics Classified Dept., Intra House, 193 Uxbridge Road, London W12 9RA. Tel: 081-743-8888, Fax: 081-743-3062

DMP POWER AMPLIFIER MODULES-TURNABLES-DIMMERS-LOUDSPEAKERS-19 INCH STEREO RACK AMPLIFIERS

OMP POWER AMPLIFIER MODULES

Supplied ready built and tested.

OMP POWER AMPLIFIER MODULES Now enjoy a world-wide reputation for quality, reliability and performance at a realistic price. Four models available to suit the needs of the professional and hobby market, i.e. industry, Leisure, Instrumental and Hi-Fi etc. When comparing prices, NOTE all models include Toroidal power supply, integral heat sink, Glass fibre P.C.B. and Drive circuits to power compatible VU meter. Open and short circuit proof.

THOUSANDS OF MODULES PURCHASED BY PROFESSIONAL USERS

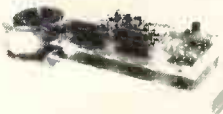

OMP100 Mk 11 Bi-Polar Output power 110 watts R.M.S. into 4 ohms. Frequency Response 15Hz - 30KHz - 3dB, T.H.D. 0.01%. S.N.R. - 118dB, Sens. for Max. output 500mV at 10K, Size 355 x 115x65mm. PRICE £33.99 + £3.00 P&P.

NEW SERIES II MOS-FET MODULES



OMP/MF 100 Mos-Fet Output power 110 watts R.M.S. into 4 ohms, Frequency Response 1Hz - 100KHz - 3dB, Damping Factor, >300, Slew Rate 45V uS, T.H.D. Typical 0.002%, Input Sensitivity 500mV, S.N.R. - 125dB, Size 300 x 123 x 60mm. PRICE £39.99 + £3.00 P&P.



OMP/MF200 Mos-Fet Output power 200 watts R.M.S. into 4 ohms, Frequency Response 1Hz - 100KHz - 3dB, Damping Factor >300, Slew Rate 50V uS, T.H.D. Typical 0.001%, Input Sensitivity 500mV, S.N.R. - 130dB, Size 300 x 155 x 100mm. PRICE £62.99 + £3.50 P&P.



OMP/MF300 Mos-Fet Output power 300 watts R.M.S. into 4 ohms, Frequency Response 1Hz - 100KHz - 3dB, Damping Factor >300, Slew Rate 60V uS, T.H.D. Typical 0.0008%, Input Sensitivity 500mV, S.N.R. - 130dB, Size 330 x 175 x 100mm. PRICE £79.99 + £4.50 P&P.

NOTE— MOS-FET MODULES ARE AVAILABLE IN TWO VERSIONS STANDARD INPUT SENS 500mV BAND WIDTH 100KHz PEC / PROFESSIONAL EQUIPMENT COMPATIBLE— INPUT SENS 775mV BAND WIDTH 50KHz ORDER STANDARD OR PEC



Vu METER Compatible with our four amplifiers detailed above. A very accurate visual display employing 11 L.E.D diodes (7 green, 4 red) plus an additional on/off indicator. Sophisticated logic control circuits for very fast rise and decay times. Tough moulded plastic case, with tinted acrylic front. Size 84 x 27 x 45mm. PRICE £8.50 + 50p P&P.

LOUDSPEAKERS



LARGE SELECTION OF SPECIALIST LOUDSPEAKERS AVAILABLE, INCLUDING CABINET FITTINGS, SPEAKER GRILLES, CROSS-OVERS AND HIGH POWER, HIGH FREQUENCY BULLETS AND HORNS, LARGE S.A.E. (30p STAMPED) FOR COMPLETE LIST.

McKENZIE:— INSTRUMENTS, P.A., DISCO, ETC.

- ALL MCKENZIE UNITS 8 OHMS IMPEDENCE
- 8" 100 WATT C8100GPM GEN PURPOSE, LEAD GUITAR, EXCELLENT MID, DISCO PRICE £28.59 + £2.00 P&P.
- RES. FREQ. 80Hz FREQ. RESP. TO 14KHz SENS. 99dB
- 10" 100 WATT C10100GP GUITAR, VOICE, ORGAN, KEYBOARD DISCO, EXCELLENT MID PRICE £34.70 + £2.50 P&P.
- RES. FREQ. 70Hz FREQ. RESP. TO 6KHz SENS. 100dB
- 10" 200 WATT C10200GP GUITAR, KEYBOARD, DISCO, EXCELLENT HIGH POWER MID PRICE £47.48 + £2.50 P&P.
- RES. FREQ. 45Hz FREQ. RESP. TO 7KHz SENS. 103dB
- 12" 100 WATT C12100GP HIGH POWER GEN, PURPOSE, LEAD GUITAR, DISCO PRICE £36.66 + £3.50 P&P.
- RES. FREQ. 45Hz FREQ. RESP. TO 7KHz SENS. 98dB
- 12" 100 WATT C12100TC TWIN CONE HIGH POWER WIDE RESPONSE, P.A., VOICE, DISCO PRICE £37.63 + £3.50 P&P.
- RES. FREQ. 45Hz FREQ. RESP. TO 14KHz SENS. 100dB
- 12" 200 WATT C12200B HIGH POWER BASS, KEYBOARDS, DISCO, P.A. PRICE £64.17 + £3.50 P&P.
- RES. FREQ. 40Hz FREQ. RESP. TO 7KHz SENS. 100dB
- 12" 300 WATT C12300GP HIGH POWER BASS LEAD GUITAR, KEYBOARDS, DISCO, ETC. PRICE £85.79 + £3.50 P&P.
- RES. FREQ. 45Hz FREQ. RESP. TO 5KHz SENS. 100dB
- 15" 100 WATT C15100BS BASS GUITAR, LOW FREQUENCY, P.A., DISCO PRICE £53.70 + £4.00 P&P.
- RES. FREQ. 40Hz FREQ. RESP. TO 5KHz SENS. 98dB
- 15" 200 WATT C15200BS VERY HIGH POWER BASS PRICE £73.26 + £4.00 P&P.
- RES. FREQ. 40Hz FREQ. RESP. TO 4KHz SENS. 99dB
- 15" 250 WATT C15250BS VERY HIGH POWER BASS PRICE £80.53 + £4.50 P&P.
- RES. FREQ. 40Hz FREQ. RESP. TO 4KHz SENS. 99dB
- 15" 400 WATT C15400BS VERY HIGH POWER, LOW FREQUENCY BASS PRICE £94.12 + £4.50 P&P.
- RES. FREQ. 40Hz FREQ. RESP. TO 4KHz SENS. 102dB
- 18" 400 WATT C18400BS EXTREMELY HIGH POWER, LOW FREQUENCY BASS PRICE £167.85 + £5.00 P&P.
- RES. FREQ. 27Hz FREQ. RESP. TO 3KHz SENS. 99dB

EARBENDERS:— HI-FI, STUDIO, IN-CAR, ETC.

- ALL EARBENDER UNITS 8 OHMS EXCEPT EB8-50 AND EB10-50 DUAL 4 AND 8 OHM, BASS, SINGLE CONE, HIGH COMPLIANCE, ROLLED FOAM SURROUND
- 8" 50 WATT EB8-50 DUAL IMPEDENCE, TAPPED 4 & 8 OHM BASS, HI-FI, IN-CAR PRICE £8.90 + £2.00 P&P.
- RES. FREQ. 40Hz FREQ. RESP. TO 7KHz SENS. 97dB
- 10" 50 WATT EB10-50 DUAL IMPEDENCE, TAPPED 4 & 8 OHM BASS, HI-FI, IN-CAR PRICE £12.00 + £2.50 P&P.
- RES. FREQ. 40Hz FREQ. RESP. TO 5KHz SENS. 99dB
- 10" 100 WATT EB10-100 BASS, HI-FI, STUDIO PRICE £27.50 + £3.50 P&P.
- RES. FREQ. 35Hz FREQ. RESP. TO 3KHz SENS. 96dB
- 12" 60 WATT EB12-60 BASS, HI-FI, STUDIO PRICE £21.00 + £3.00 P&P.
- RES. FREQ. 28Hz FREQ. RESP. TO 3KHz SENS. 92dB
- 12" 100 WATT EB12-100 BASS, STUDIO, HI-FI, EXCELLENT DISCO PRICE £32.00 + £3.50 P&P.
- RES. FREQ. 26Hz FREQ. RESP. TO 3KHz SENS. 93dB
- FULL RANGE TWIN CONE, HIGH COMPLIANCE, ROLLED SURROUND**
- 5 1/4" 60 WATT EB5-60TC (TWIN CONE) HI-FI, MULTI-ARRAY DISCO ETC. PRICE £9.99 + £1.50 P&P.
- RES. FREQ. 63Hz FREQ. RESP. TO 20KHz SENS. 92dB
- 6 1/4" 60 WATT EB6-60TC (TWIN CONE) HI-FI, MULTI-ARRAY DISCO ETC. PRICE £10.99 + £1.50 P&P.
- RES. FREQ. 38Hz FREQ. RESP. TO 20KHz SENS. 94dB
- 8" 60 WATT EB8-60TC (TWIN CONE) HI-FI, MULTI-ARRAY DISCO ETC. PRICE £12.99 + £1.50 P&P.
- RES. FREQ. 40Hz FREQ. RESP. TO 18KHz SENS. 89dB
- 10" 60 WATT EB10-60TC (TWIN CONE) HI-FI, MULTI-ARRAY DISCO ETC. PRICE £16.49 + £2.00 P&P.
- RES. FREQ. 35Hz FREQ. RESP. TO 12KHz SENS. 86dB

TRANSMITTER HOBBY KITS

PROVEN TRANSMITTER DESIGNS INCLUDING GLASS FIBRE PRINTED CIRCUIT BOARD AND HIGH QUALITY COMPONENTS COMPLETE WITH CIRCUIT AND INSTRUCTIONS

- 3W FM TRANSMITTER 80-108MHz, VARICAP CONTROLLED PROFESSIONAL PERFORMANCE, RANGE UP TO 3 MILES, SIZE 38 x 123mm SUPPLY 12V @ 0.5AMP. PRICE £14.49 + £1.00 P&P.
- FM MICRO TRANSMITTER (BUG) 100-108MHz VARICAP TUNED COMPLETE WITH VERY SENS FET/MIC RANGE 100-300m SIZE 36 x 46mm SUPPLY 9V BATT. PRICE £8.62 + £1.00 P&P.



POSTAL CHARGES PER ORDER £1.00 MINIMUM. OFFICIAL ORDERS WELCOME FROM SCHOOLS/ COLLEGES/ GOVT BODIES ETC. PRICES INCLUSIVE OF V.A.T. SALES COUNTER VISA ACCESS ACCEPTED BY POST, PHONE OR FAX



OMP VARISPEED TURNTABLE CHASSIS



★ MANUAL ARM ★ STEEL CHASSIS ★ ELECTRONIC SPEED CONTROL 33 & 45 ★ VARI PITCH CONTROL ★ HIGH TORQUE SERVO DRIVEN DC MOTOR ★ TRANSIT SCREWS ★ 12 DIE CAST PLATTER ★ NEON STROBE ★ CALIBRATED BAL WEIGHT ★ REMOVABLE HEAD SHELL ★ CARTRIDGE FIXINGS ★ CUE LEVER ★ POWER 220 240V 50 60Hz ★ 390 x 305mm ★ SUPPLIED WITH MOUNTING QUT-OUT TEMPLATE
PRICE £59.99 + £3.50 P&P.

OPTIONAL MAGNETIC CARTRIDGES

STANTON AL500
PRICE £16.99 + 50p P&P

GOLDRING G850
PRICE £6.99 + 50p P&P

OMP MOS-FET POWER AMPLIFIERS, HIGH POWER TWO CHANNEL 19" INCH RACK

THOUSANDS PURCHASED BY PROFESSIONAL USERS



NEW MXF SERIES OF POWER AMPLIFIERS
THREE MODELS:— MXF200 (100w + 100w)
MXF400 (200w + 200w) MXF600 (300w + 300w)
All power ratings R.M.S. into 4 ohms.

FEATURES: ★ Independent power supplies with two Toroidal Transformers ★ Twin L.E.D. Vu meters ★ Rotary indexed level controls ★ Illuminated on/off switch ★ XLR connectors ★ Standard 776mV inputs ★ Open and short circuit proof ★ Latest Mos-Fets for stress free power delivery into virtually any load ★ High slew rate ★ Very low distortion ★ Aluminium cases ★ MXF600 Fan Cooled with D.C. Loudspeaker and Thermal Protection

USED THE WORLD OVER IN CLUBS, PUBS, CINEMAS, DISCOS ETC.

SIZES:— MXF 200 W19" x H3 1/2" (2U) x D11"
MXF 400 W19" x H5 1/4" (3U) x D12"
MXF 600 W19" x H5 1/4" (3U) x D13"

MXF200 £171.35
MXF400 £228.85
MXF600 £322.00
SECURICOR DELIVERY £12.00 EACH

OMP LINNET LOUDSPEAKERS

THE VERY BEST IN QUALITY AND VALUE



MADE ESPECIALLY TO SUIT TODAY'S NEED FOR COMPACTNESS WITH HIGH OUTPUT SOUND LEVELS. FINISHED IN HARDWEARING BLACK VYNDIE WITH PROTECTIVE CORNERS, GRILLE AND CARRYING HANDLE INCORPORATES 12" DRIVER PLUS FULL FREQ RANGE 45Hz-20KHz BOTH MODELS 8 OHM. SIZE H18" x W15" x D12"

CHOICE OF TWO MODELS

POWER RATINGS QUOTED IN WATTS RMS FOR EACH CABINET
OMP 12-100 (100W 100dB) PRICE £159.99 PER PAIR
OMP 12-200 (200W 102dB) PRICE £209.99 PER PAIR

SECURICOR DEL.— £12.00 PER PAIR

OMP SLIDE DIMMER

1K WATT & 2.5K WATT
CONTROLS LOADS UP TO 1KW & 2.5KW SUITABLE FOR RESISTIVE AND INDUCTIVE LOADS BI-ACK ANODISED CASE READILY FLUSH MOUNTED THROUGH PANEL CABINET CUT-OUTS. ADVANCED FEATURES INCLUDE:—

- Full 1/2 65mm SI IDF TRAVEL
- NFON
- MONITOR INDICATOR
- FI ASH OVRRIDE BUTTON
- HIGH & LOW I/F V/FI PRESETS
- FULLY SUPPRESSED TO BS 800

SIZES:—
1KW H128 - W40 - D55mm
2.5KW H128 - W76 - D79mm
PRICES:— 1K WATT £15.99
2.5K WATT £24.99 + 60p P&P

PIEZO ELECTRIC TWEETERS-MOTOROLA

PIEZO ELECTRIC TWEETERS — MOTOROLA

Join the Piezo revolution. The low dynamic mass (no voice coil) of a Piezo tweeter produces an improved transient response with a lower distortion level than ordinary dynamic tweeters. As a crossover is not required these units can be added to existing speaker systems of up to 100 watts (more if 2 put in series). **FREE EXPLANATORY LEAFLETS SUPPLIED WITH EACH TWEETER.**

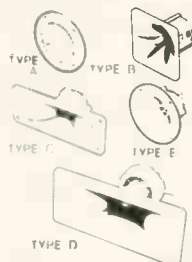

'TYPE 'A' (KSN2036A) 3" round with protective wire mesh, ideal for bookshelf and medium sized Hi-Fi speakers. Price £4.90 each + 50p P&P
TYPE 'B' (KSN1005A) 3 1/2" super horn. For general purpose speakers, disco and P.A. systems etc. Price £5.00 each + 50p P&P
TYPE 'C' (KSN6016A) 2" x 5" wide dispersion horn. For quality Hi-Fi systems and quality discos etc. Price £6.99 each + 50p P&P
TYPE 'D' (KSN1025A) 2 x 6" wide dispersion horn. Upper frequency response retained extending down to mid range (2KHz). Suitable for high quality Hi-Fi systems and quality discos. Price £9.99 each + 50p P&P
TYPE 'E' (KSN1038A) 3 1/2" horn tweeter with attractive silver finish trim. Suitable for Hi-Fi monitor systems etc. Price £5.99 each + 50p P&P
LEVEL CONTROL Combines on a recessed mounting plate, level control and cabinet input jack socket. 85 x 85mm. Price £3.99 + 50p P&P

STEREO DISCO MIXER

STEREO DISCO MIXER with 2 x 5 band L & R graphic equalisers and twin 10 segment L.E.D. Vu Meters. Many outstanding features 5 inputs with individual faders providing a useful combination of the following:—
3 Turntables (Mag.) 3 Mics. 4 Line including CD plus Mic with talk over switch Headphone Monitor. Pan Pot L & R. Master Output controls. Output 775mV. Size 360 x 280 x 90mm. Supply 220-240V.
Price £134.99 — £4.00 P&P



B. K. ELECTRONICS Dept PE
UNIT 5, COMET WAY, SOUTHWEND-ON-SEA, ESSEX. SS2 6TR
TEL: 0702-527572 FAX: 0702-420243

Techniques

Andrew Armstrong explains standing waves and train controllers.

SWR is often misunderstood. The voltage standing wave ratio is the ratio of maximum to minimum AC voltage on a transmission line. If the line is perfectly matched, the same voltage will appear everywhere, but a mismatch, which would reflect power back from antenna to transmitter, gives rise to a series of nodes and antinodes along the length of the line.

There is a fixed relationship between the ratio of node to antinode voltage and the proportion of the power reflected from the antenna. Table 1 shows some typical values. As you can see, most of the transmitter power is radiated even in the presence of what most people would regard as an excessively high SWR.

The reflection of power from the antenna is not the whole story. When the power reaches the transmitter some of it will be absorbed by the output stage,

heating it up, and some will be reflected back to the antenna. Of the latter, some will be radiated, and some will be reflected again. Even with a high SWR, it is possible for most of the transmitter power to be radiated.

The snag with a high SWR is that semiconductor transmitter output stages can be damaged by having power reflected back into them. In addition to heating the output transistor, the reflected power increases the peak voltage on the output stage. Many RF power transistors do not have very high voltage ratings, so they can easily be damaged by high levels of reflected power. For this reason, most transmitters include protection circuits which reduce output power if reflected power is detected.

One effect of this is that transmitter power is reduced, and in most cases this causes much more reduction to the transmitted

signal than does the reflection itself. It is for this reason that it is worth reducing SWR to a low level in most cases.

SWR Measurement

Two types of circuit are in common use for swr indication. Fig. 1 shows a very low cost design, but one which responds better at higher frequencies, and which cannot provide a measurement of power. Fig. 2 shows a design which has a more even response, but which costs more.

Both circuits rely on the fact that the voltage and current are in phase on a matched transmission line. In the design shown in Fig. 1, power is coupled to each of the two pickup lines both inductively and capacitively. In phase voltage and current add on one line, and subtract on the other. Proper choice of resistor value R will ensure that the subtraction results in cancellation of the signal on one line and doubling of that on the other.

Reflected power will put the current and voltage out of phase, so that complete cancellation will no longer occur, and reflected power will be indicated.

The circuit of Fig. 2 uses a pickup coil wound on a torroid for inductive pickup. This is capacitively shielded from the transmission line, so there is no frequency dependent effect here. A voltage signal is supplied by a resistive divider, and the addition and cancellation works as described above. This circuit has the advantage that it performs uniformly over the range of

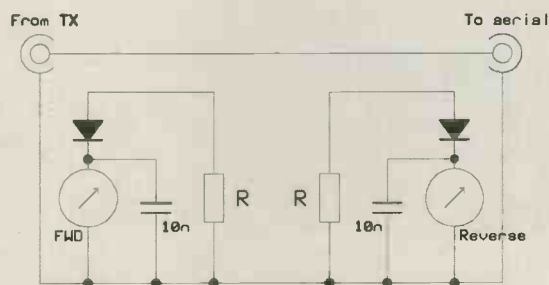

Fig. 1. low cost design.

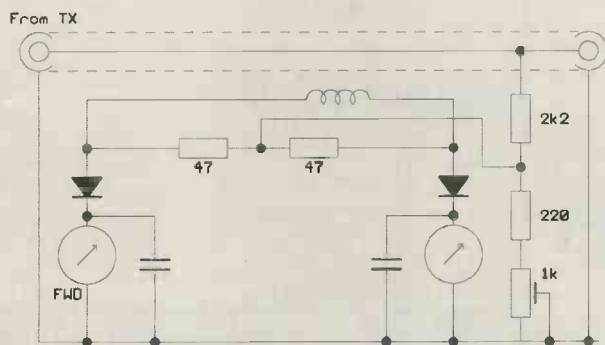

Fig. 2. This method has a better response.3

Table 1

% of power reflected	SWR
0	1:1
20	1.5:1
33	2:1
50	3:1

frequencies for which leakage inductance is small, and the effects of stray capacitance are small, compared with the wanted part of the coupled signals.

With careful assembly and choice of components, one instrument of this type can function over two decades of frequency. If you want to build your own SWR meter, the circuit of Fig. 1 is recommended if it is only to be used over a limited frequency range such as the CB band, while the design of Fig. 2 is more suitable for a general purpose instrument.

Train Controller

Do you have among your past issues a construction feature for a thyristor controller for 12V model railways, and if so could I please have a copy?

Michael Vaughn
Haslemere
Surrey

I cannot recall such a project, but here is a design which you may be able to use. Assuming that you want to phase control the power to the motor using the triacs, the circuit shown in Fig.3 should be adaptable for the purpose.

This design uses a full-wave bridge rectifier employing diodes in one half and thyristors in the other. The thyristors are phase-controlled to give pulses of DC of similar shape to the AC pulses produced by a conventional lamp-dimmer. Fig. 4 shows a typical output waveform, from the thyristor-controlled bridge. To carry out phase control, the first thing needed is a timing reference. This is generated by Q1, whose base is fed from its own half-bridge using 1N4148 signal diodes. This keeps the transistor switched on through most of the cycle, allowing it to switch off briefly around zero crossings. This generates a reset pulse which is used to reset a ramp generator.

The ramp generator employs

one-quarter of a quad Norton opamp. This sort of opamp responds to current rather than voltage signals on its inputs, so that the output remains at zero if the two input currents are the same.

The current into the non-inverting input is set to approximately 11µA by RV1 and R4. The output voltage then changes in such a way as to charge C1 at 11µA. Simple calculation shows that this will produce a 5V ramp at a frequency of 100Hz (because the ramp generator is reset 100 times per second).

This ramp signal is added to an adjustable DC signal at the non-inverting input of a second Norton opamp, wired as a comparator. The inverting input of this comparator is biased, so that it cannot quite be switched over by the ramp signal alone. If the speed potentiometer, RV2, is advanced to provide some DC signal in addition to the ramp, then the opamp will switch over near the end of the ramp.

The more DC signal is applied, the earlier in the ramp the opamp will switch over, until, with the pot fully advanced, the opamp will remain switched over all the time. The output of this comparator controls Q2, which switches the input to a pair of thyristor optoisolators. These are used to trigger the thyristors forming part of the

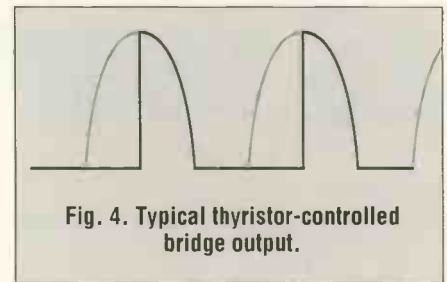

Fig. 4. Typical thyristor-controlled bridge output.

bridge: these thyristors are therefore phase-controlled, with timing derived from the ramp waveform.

The power supply for the electronics is derived from yet another half-bridge rectifier, with a conventional smoothing capacitor and voltage regulator IC.

To adjust RV1, first set RV2 for minimum speed, then adjust RV1 until the thyristors just trigger at the end of the waveform. Then turn RV1 back until they just stop triggering. This is all the calibration required for the unit.

Because of the effects of leakage reactance in the mains transformer, the timing of the ramp reset pulses may vary as the loading is changed. In some cases, this could cause anomalous speed changes at one end or other of the control range. If this problem occurs, experiment with capacitors in the range 100nF to 10µF (non-polarised) in parallel with R1 or R2, providing phase advance and retard respectively. ■

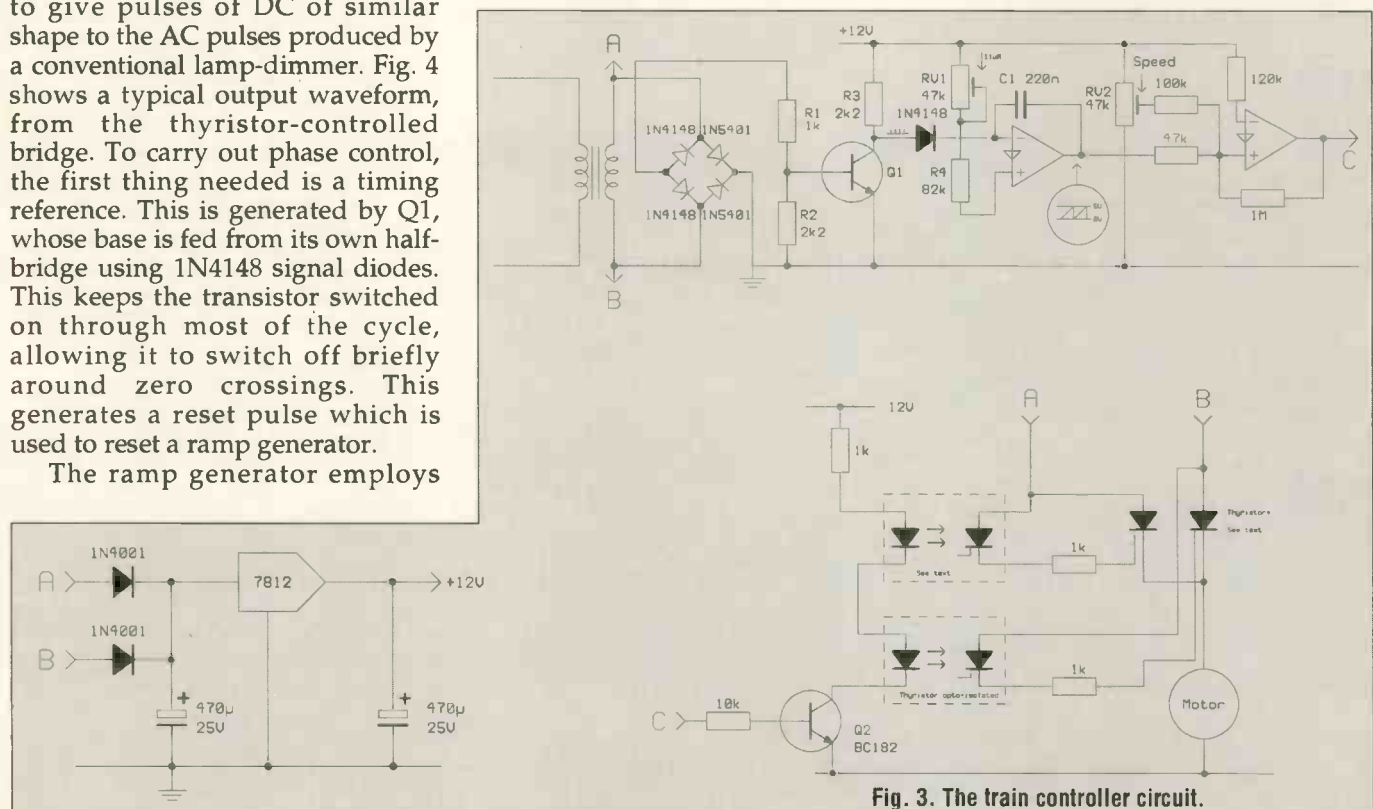

Fig. 3. The train controller circuit.

25 Years

UK in the Space Race? A computer with 1k of RAM? PE has seen it all.

May 1966

The editorial 25 years ago this month mentioned that fact that UK ought to be getting into the Space Race. Not for the fun of it, but because of the need for good communications and the use of satellites. The Space Race was still in its infancy with the USA and USSR competing to see who could get the biggest craft aloft. As the editor of the time said, 'Can we afford not to participate in space?'

Interesting features this month included radio control of models, using the free transistor guide and a beginners' guide to mounting valves.

1976

The editorial ten years later concerned the apparent cheapness of components. This is one of the reasons why electronics became a hobby in the first place. The editor voiced his concern over the cheapness of digital watches where the cost of the non-active parts of the design were more expensive than the electronics. The amount of electronics that could be crammed onto a chip in 1976 was nothing compared with present day capabilities and the throw-away watch is now a reality. Fortunately, there seems to be no devaluation of high technology so the worries of ten years ago were unfounded.

1981

It seems that May was the month for free gifts, 1966 had its transistor guide, 1976 a piece of stripboard and 1981 a project case. The magazine also featured a new look News and Market Place. This featured the new ZX81 from Uncle Clive costing £69.95 and £49.95 in kit form. It had an 8k Basic in ROM, a40 key touch keypad and an 'amazing' one kbyte of RAM. Also featured was a Prestel Adaptor at a cost of £200 and a portable black and white TV from JVC costing £295. It seems that electronics gadgets have definitely become cheaper, especially personal computers.

1986

Looking through the What's New section of five years ago showed that LCD technology has not progressed a great deal. The latest was a 640x200 line display from Epson, billed as a replacement for the CRT. In the What's To Come section, much was made of the new colour LCD displays soon to be available for portable TVs. It has taken five years for them to see the light of day in portable computers. Barry Fox gave one of the first full descriptions of DAT, a technology that never took off and withadvent of DCC, probably never will. ■

WE HAVE THE WIDEST CHOICE OF USED OSCILLOSCOPES IN THE COUNTRY

TEKTRONIX 2445 Four Trace 150MHz Dual TB	£1200
TEKTRONIX 2245A Four Trace 100MHz Dual TB	£1000
TEKTRONIX 2235 Dual Trace 1000MHz Delay Sweep	£650
TEKTRONIX 2215 Dual Trace 50MHz Delay Sweep	£450
TEKTRONIX 475 Dual Trace 200MHz Delay Sweep	£550
TEKTRONIX 465 Dual Trace 100MHz Delay Sweep	£450
H.P. 1722B Dual Trace 275MHz Delay Sweep, 5 Function LED Display for Real Time Measurement	£750
H.P. 1740A Dual Trace 100MHz Delay Sweep Trig	£350
PHILIPS PM217 Dual Trace 50MHz Delay Sweep	£400
TELEQUIPMENT D775 Dual Trace 50MHz Delay Sweep	£250
GOULD OS3000 Dual Trace 40MHz Delay Sweep TV Trig	£250
GOULD OS1100 Dual Trace 30MHz TV Trig	£180
GOULD OS300 Dual Trace 20MHz	£250
GOULD OS250R Dual Trace 15MHz TV Trig	£160
COBSOR CDU150 Dual Trace 35MHz Delay Sweep from £100	£150
S.E. LABS SM111 Dual Trace 18MHz	£130
TEKTRONIX 2210 Digital Storage Dual Trace 50MHz (20MS/s Sampling Rate) As New	£1150
GOULD 4035 Digital Storage Dual Trace 20MHz	£750
GOULD OS4020 Digital Storage Dual Trace 10MHz	£450
GOULD OS4000 Digital Storage Dual Trace 10MHz	£300
THIS IS JUST A SAMPLE - MANY OTHERS AVAILABLE	
H.P. 8112A Programmable Pulse Generator 50MHz	£1500
BRADLEY Oscilloscope Calibrator 192 with Cal Cert.	£800
DATRON 1061 Auto Cal DMM True RMS etc.	£650
SOLARTRON 7075 DVM up to 7 1/2 digit AC/RMS/DC/OHM	£700
R&S SW084 (Sweep Gen with display) 0.1-1000MHz	£750
MARCONI TF2008 AM/FM 10KHz-510MHz Sig Gen	£450
MARCONI TF2015 AM/FM 10-520MHz Sig Gen with TF2171	£400
MARCONI TF2015 with Synchroniser TF2171	£250
V TF2016 AM/FM 10KHz-120MHz Sig Gen with TF2173	£350
MARCONI TF2016 without Synchroniser TF2173	£175
MARCONI TF2356/2357 Level Osc/Meter 20MHz ..the pair	£950
H.P. 8620C Sweeper Main Frame (Pkg-ns available)	£1000
LEADER LV5581A Vectorscope	£600
TEKTRONIX 491 SPEC ANALYSER 1.5-12.4GHz from £1000-£1400	£1400
SYSTRON DONNER 1702 Sig Gen 100Hz-1GHz	£950
POLARAD Sig Gen 1105B 0.2-4.4GHz	£500
POLARAD Sig Gen 1105B 1.8-4.4GHz	£500
POLARAD Sig Gen 1207A 3.7-4.4GHz	£500
POLARAD Sig Gen 1207A with 1509 Freq Doubler	£750
POLARAD Sig Gen 1208A 8.95-11GHz	£500
POLARAD Sig Gen 1208A with 1510 Freq Doubler	£750
TEKTRONIX 1M504 with PG50C SG503/TC501	£2250
RACAL STORE 14DS 14 Channel Magnetic Tape Recorder	£2000
MARCONI 9081 Synthesiser Sig Gen 8-520MHz	£650
RACAL 9009 Mod Meter 10MHz-1.5GHz	£350
RACAL 9301 RMS Voltmeter 10KHz-1.5GHz	£250
TIME 2004 DC Voltage Standard 0.005%	£450
SOLARTRON 7150 Digital Multimeter 6 1/2 digit	£300
AVC Valve Characteristic Meter VCM163	from £250 £350
FERROGRAPH RTS2 Recorder Test Set	from £200
THURLBY PL320MD Twice 30V 2A Quad Mod Digital	£200

TELEQUIPMENT CT71 Curve Tracer	£250
MARCONI TF2700 Universal LCR Bridge, Battery from	£125
MARCONI TF237A Automatic Distortion Meter 400Hz/1KHz	£100
MARCONI MOD Meters TF2300, TF2300B; TF2303 from	£100
MARCONI TF2603 RF Millivoltmeter 50KHz-1.5GHz	£75
MARCONI TF2430 Digital Freq Counter 10Hz-80MHz	£60
MARCONI TF15201 RF Power Meter 500MHz-1025MHz 500mW	£25
MARCONI TF893A AF Power Meter 20Hz-35KHz 20mW 10W	£20
RACAL 9915 Freq Counter 10-520MHz Crystal Oven	£150
FARNELL PSU H30/100 0-30V 0-100A	£750
UNINTERRUPTED Power Supply type RBS-AC 500VA	£150

AVO 8 - MULTIMETERS
GOOD WORKING ORDER - PHYSICALLY NOT BRILLIANT SUPPLIED WITH BATTERIES & LEADS ONLY £30
ALL OTHER MODELS AVAILABLE

LEADER LMV198A Two Ch Mv/meter 5Hz-500KHz/1mV-300V KIKUSUI AVM23 AC Voltmeter Dual Ch-10Hz-500KHz 300uV-100V
Solartron 7045 Multimeter 4 1/2 digit 30 ranges Auto/Man FARNELL Pulse Gen System 1Hz-10MHz Single/Double LOGIC PROBE type 33000A TTL/CMOS (P&P £3)
Large range of BENCH POWER SUPPLIES available from X-Y PLOTTERS Various Models from £25-£400

SOME BRUEL & KJØER EQUIPMENT ALWAYS AVAILABLE. PLEASE ENQUIRE.

LEVELL TM3B AC Microvoltmeter 1Hz-3MHz 5uV-500V £50
LEVELL TM3A AC Millivoltmeter 1Hz-3MHz 5uV-500V £40
LEVELL Oscillator TG152 3Hz-300KHz Sine Sq from £55
LEVELL Oscillator TG150M 1.5Hz-150KHz Sine Wave £20
LEVELL Decade Osc TF66A 0.2Hz-1.22MHz Low dist from £35

NEW EQUIPMENT

HAMEG OSCILLOSCOPE HM1005 Triple Face 100MHz Delay Timebase £792
HAMEG OSCILLOSCOPE HM604 Dual Trace 60MHz Delay Sweep £610
HAMEG OSCILLOSCOPE HM203 7 Dual Trace 20MHz Component Tester £338
HAMEG OSCILLOSCOPE HM205 3 Dual Trace 20MHz Digital Storage £810
All other models available - all oscilloscopes supplied with 2 probes



BLACK STAR EQUIPMENT (P&P all units £5)
APOLLO 10 100MHz Ratio Period Time Interval etc £222
APOLLO 100 100MHz (As above with more functions) £295
METEOR 100 FREQUENCY COUNTER 100MHz £109
METEOR 600 FREQUENCY COUNTER 600MHz £135
METEOR 1000 FREQUENCY COUNTER 1GHz £178
JUPITOR 500 FUNCTION GEN 0.1Hz-500KHz Sine Sq In £110
ORION COLOUR BAR GENERATOR Pal TV Video £209
All other Black Star Equipment available

HUNG CHANG DMM 7030 3 digit Hand held 28 ranges including 10 amp AC/DC 1% ACC (P&P) £4 £39.50
As above DMM60100 25% £33.50
Carrying cases for above £3.00 ea

OSCILLOSCOPE PROBES Switched X1X10 (P&P £3) £11

This is a very small sample of stock. SAE or telephone for LIST of OVER 700 ITEMS. Please check availability before ordering. CARRIAGE all units £16. VAT to be added to total of goods and carriage.

STEWART OF READING
110 WYKHAM ROAD, READING, BERKS RG6 1PL
Tel: 0734 68041 Fax: 0734 351696
Callers welcome 9am to 5.30pm MON-FRI (UNTIL 8pm THURS)



NATIONAL COLLEGE OF TECHNOLOGY

Packaged Short Courses

The National College of Technology (NCT Ltd) offers a range of packaged short courses in analogue electronics, digital electronics & fibres, optoelectronics & programmable logic controllers for study at home or at work. The advantages are that you may,

- commence at any time
- work at your own pace
- have a tutor (optional)

and there is no travelling involved. BTEC certificates are available subject to the conditions of the award. These highly popular packed courses contain workbooks, a cassette tape, circuit board and components necessary to provide both theoretical and practical training.

Whether you are a newcomer to electronics or have some experience and simply need updating, there is probably a packaged short course ready for you. Write or telephone for details, quoting Practical Electronics, to:

NCT Ltd, Bicester Hall
5 London Road, Bicester
Oxon OX6 7BU
or telephone (0296) 613067 Ext. 202

PE Scans The Latest Books

This month's reviews take a look at the exploits ESA, the operation of the atmosphere and the design of superheterodyne radio receivers.

Currently Press Publications Editor at the European Space Agency (ESA), Beatrice Lacoste is in a good position to observe the aims and achievements of ESA.

Presumably due to the author's occupation, the style reads more like marketing hype than informative good readable writing. Starting off with an overview of Europe's success in space and its participation in quite a few US coups, the book examines the Ariane launch system and looks forward to the Columbus Free Flying space station and trips to Mars. One of the more interesting chapters is that concerning the amount of 'space junk' now in orbit – there are around 7000 objects the size of tennis balls or larger in orbits up to 36,000km.

Subsequent chapters look at various aspects of space operations, from satellites looking down to those which look outward, including the HST (Hubble Space Telescope) and its unfortunate malady.

ESA's future seems to be to look deeper into space and, while commercial satellites provide a source of income, the real work of ESA is about exploring the universe. However, without support from the various government, none of this will be possible. In the real world, space costs money – lots of it – so commercial development will have to come first.

Title: Europe: Stepping stones to space
Author: Beatrice Lacoste
Price: £10.95
Publisher: Orbic Ltd.
ISBN: 1-873244-00-2

There are around 7000 objects the size of tennis balls or larger in orbit...

On The Air

This book is a mine of information concerning the structure of the atmosphere. After all, understanding how radio waves are transmitted through it requires a pretty intimate knowledge.

Starting off with a look at the sun, complete with diagrams and figures such as the sun's output being 340×10^{24} watts, the book paves the way for an understanding of how it affects the atmosphere. The following chapters cover sunspots, the Maunder Minimum and the ionosphere and its various layers before getting on to radio propagation.

Unfortunately, the chapter entitled Radio Wave Propagation doesn't actually describe how this works. A brief look at the electric and magnetic fields of a radio wave gives no real clue as to how radio waves are generated and received in aerials. Instead, the author concentrates on how they get from A to B and what affects them while they are travelling.

The next chapters look at transmissions through the troposphere, Earth, Moon, Earth bouncing, satellites and meteor scatter. The main body of the book

then finishes up with a chapter on noise generated in the atmosphere and its resultant effects on radio transmissions.

The writing style is easily understood and not terribly technical. A good book for the fundamentals.

Title: An Introduction To Radio Wave Propagation.

Author: J G Lee

Price: £3.95

Publisher: Bernard Babani BP293

ISBN: 0-85934-238-7

Build A Superhet

RA Penfold must be one of the most prolific writers in the hobby electronics field. His latest offering describes how to build a superheterodyne radio receiver.

Chapter one describes how the superhet works and why it is better than a tuned radio frequency (TRF) receiver. The next chapter looks at the basic circuit diagrams, explaining how they operate. All of the circuits are designed to be constructed and full component lists are given. Unusually, very little information is given on how to build the physical unit – there are no PCBs or stripboards in sight.

The final chapter looks at additional circuits to enhance the performance of the basic receiver: a signal strength meter, various filters and mains power supply.

Title: Short Wave Superhet Receiver Construction

Author: R A Penfold

Price: £2.95

Publisher: Bernard Babani BP276

ISBN: 0-85934-221-2

The Fox On Philips

Barry talks to the President of Philips about DCC, Astra and his resignation.

Philips is now nearly a hundred years old and company employees have worked on the warm assumption that there will always be a Philips, with their jobs and pension secure.

Now, under the new President Jan Timmer, there is a storm of change. Philips ended 1990 with a net loss. Sales were down 3% and there is talk of Japanese Matsushita buying a stake.

Jan Timmer refuses to give press interviews so the company's AGM in Eindhoven was a rare opportunity to hear him speak frankly and answer questions. He began by explaining why he gives no press interviews.

"I have no time for them. My shareholders would object if I spent half my time talking to journalists and that's how long it would take me. It's also not right that my ideas should be published first and then discussed. And if what I say is bland then it is not worthwhile giving the interview".

Timmer uses the saved time for talking with as many employees as possible. His Centurion programme (with allusions to the tank, a hundred years of Philips and the personal commitment of Roman soldiers) began last October. It has come as a nasty shock to the passengers who have grown accustomed to the luxury of buck-passing. Every employee, whatever their status, is now accountable for everything they do, or fail to do.

If Philips doesn't become profitable will Timmer resign?"

"Yes".

Will Philips clear the air by releasing the now famous, or infamous, letter written by Peter Groenenboom to the EC in Brussels? Groenenboom is head of the TV divisions at Philips and a staunch supporter of the MAC transmission system. He wrote to the EC complaining that Astra and Sky were exploiting a loophole in the EC's 1986 Directive which requires that all satellite

broadcasters use MAC.

Astra is classed as a communications satellite because it operates on lower powers and frequencies than the direct broadcast satellites. The original Directive expires at the end of 1991 and Groenenboom wanted the EC to close the loophole. So Sky and the German TV channels broadcasting from Astra in PAL would have to switch to MAC, leaving several million viewers with PAL receivers staring at blank screens.

Like a kindergarten squabble, Astra has been complaining about

Matsushita is the largest consumer electronics company in the world and its support is the key to success

what Astra says Philips has been saying about Astra! Surely the simple answer is for Philips to tell the world what Groenenboom actually said to the EC?

"You are right that this campaign was provoked by the letter from Peter Groenenboom," says Timmer. "But we did not release it. I do not think a private letter to the EC can be published by us. The EC will have to agree. I have seen the letter and I do not believe that the discussion would have been clearer and less emotional if the letter had been published. I believe far more would have been written if the letter had been published".

Late in 1990, Philips was confident that when DCC was

formally unveiled at the January Consumer Electronics Show in Las Vegas, Matsushita (Panasonic/Technics) would stand up and be counted as co-developer, backer and licensor of the new format. Matsushita is the largest consumer electronics company in the world and its support is the key to success of any new product. But at Las Vegas Matsushita remained silent and Philips was left able to talk only vaguely about a "major Japanese manufacturer" being partner in the venture. Matsushita's subsidiary companies round the world were told to say nothing.

A couple of months later, and just before Philips' AGM, Mike Aguillar, Vice President of Technics in the USA, said he was finally authorised to confirm that DCC was a joint venture between Matsushita and Philips. All looked set for a confidence-boosting fanfare at Eindhoven.

But Timmer said nothing about DCC.

In the light of the US announcement, would Timmer identify Philips's Japanese partner in DCC?

"We agreed not to say anything about the involvement of our Japanese colleagues in DCC until they had made their own announcements. I did not know that a senior officer of Matsushita had said that. I do not know whether he was authorised by his head office in Japan to make that statement. But managers make statements. Even in Philips managers sometimes make statements. But I will say this...."

We do not deny what the senior executive said".

The industry is full of rumours about further joint ventures between Philips and Matsushita. "I can honestly say that everybody talks with everybody about joint ventures", says Timmer.

True, last year Sony had been planning to pledge support for DCC, too. ■

EASY-PC, SCHEMATIC and PCB CAD

Over 7500 Installations
in 50 Countries Worldwide!

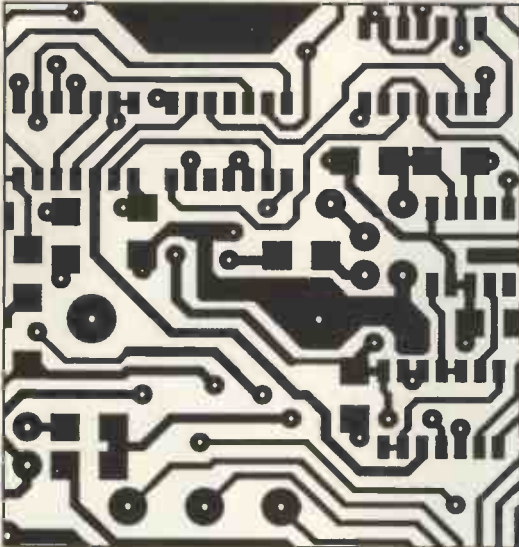

- Runs on:- PC/XT/AT/286/386/486 Herc CGA EGA VGA.
- Design:- Single sided, Double sided and Multilayer boards.
- Provides Surface Mount support.
- Standard output includes Dot Matrix / Laser / Inkjet Printer, Pen Plotter, Photo-plotter and N.C. Drill.
- Superbly easy to use.
- Not copy protected.

Still Only £98.00!
Plus P&P+VAT

BRITISH DESIGN AWARD 1989

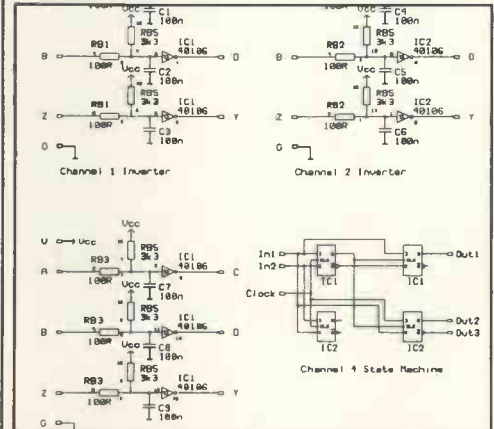

Standard Library includes over 400 Symbols.
Additional Libraries available.

AC CIRCUIT ANALYSIS ANALYSER II £195

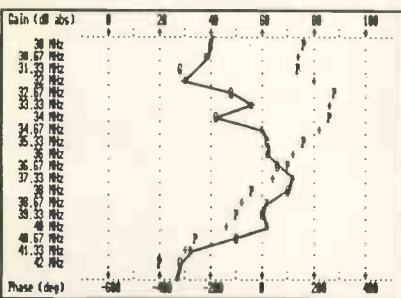
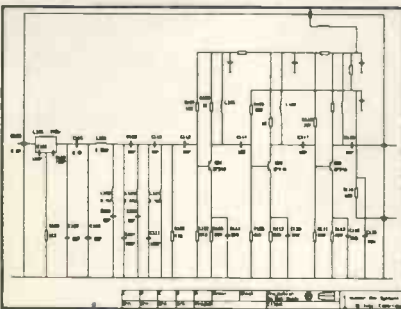

- Evaluate the performance of your designs prior to breadboarding.
- Make modifications to them and assess the new performance in minutes, rather than hours or days.
- ANALYSER II can save thousands of pounds in test equipment

EVALUATE DESIGN MODIFICATIONS IN MINUTES!

SMITH CHART CAD Z-MATCH II £195

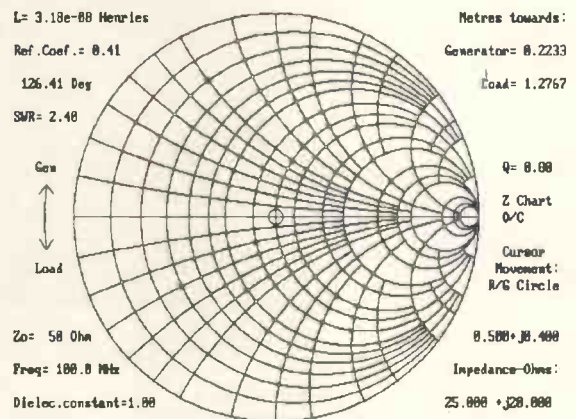

Z-MATCH II takes the drudgery out of RF matching problems and includes many more features than the standard Smith Chart. Provides solutions to matching problems using transmission line transformers, stubs, discrete components etc.etc.. Supplied with comprehensive user instructions including many worked examples.

For full information, Write, Phone or Fax:-

Number One Systems Ltd. I

REF: PE, HARDING WAY, ST.IVES, HUNTINGDON, CAMBS, ENGLAND, PE17 4WR.

Telephone: 0480 61778 (7 lines) Fax: 0480 494042

International: +44-480-61778, l'Fax: +44-480-494042 ACCESS, AMEX, MASTERCARD, VISA Welcome.

The CAD Specialists

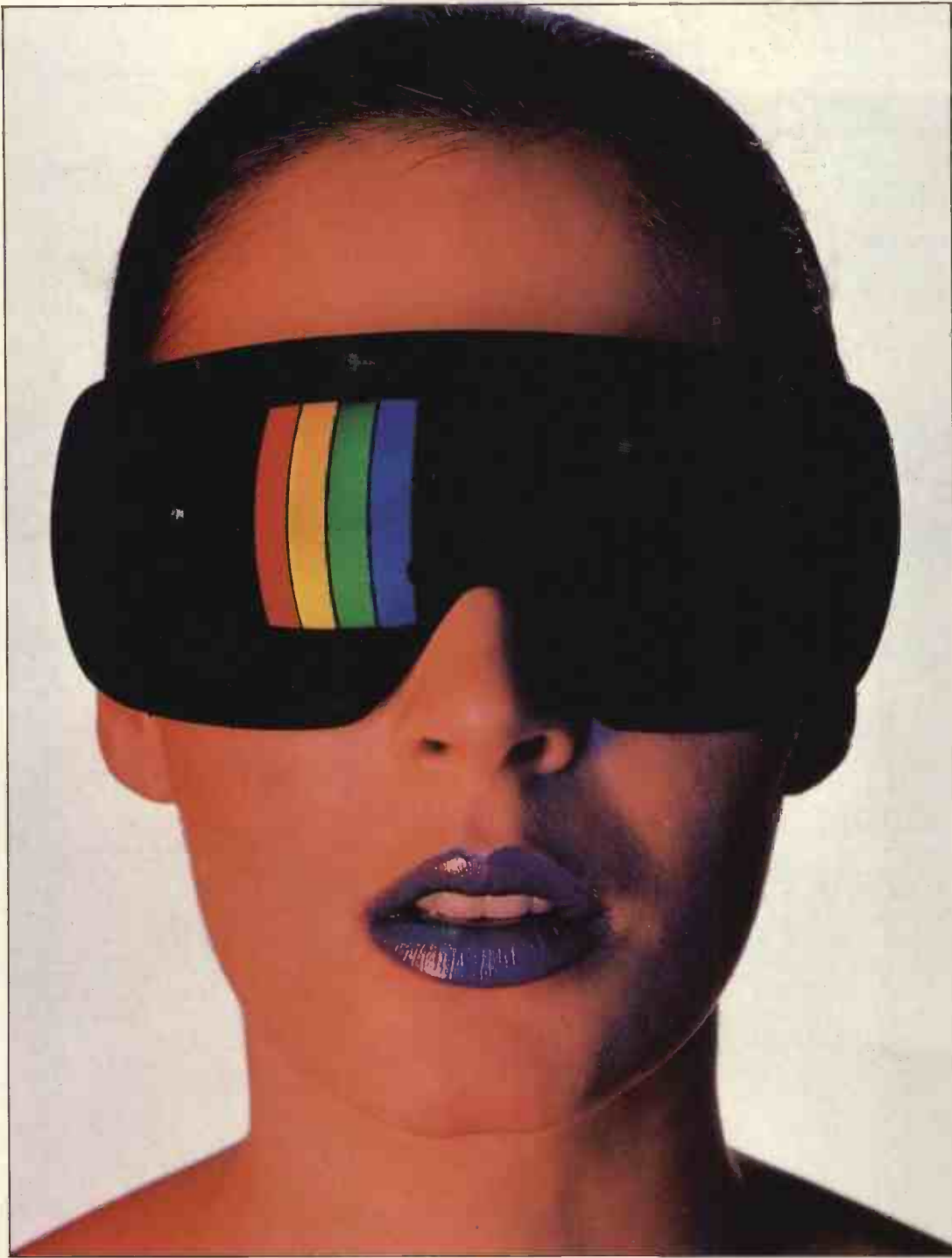

NICAM!

...set your sights on a better sound!

Experience a new sensation. An experience that opens up a whole new spectrum of sound.

Put yourself on stage at the Albert Hall, surrounded by a great orchestra. Imagine the sound you will hear, every nuance, every note; or travel up the Nile with an intrepid explorer, a journey not only full of breathtaking beauty and colour, but rich in the sounds of another continent; or capture the hidden gasps of 100,000 hardened fans at Wembley for the F.A. Cup Final, when the ball skims the crossbar with the last kick of the match; follow with your ears as well as your eyes, dodging the bullets, as your favourite hero battles out of yet another tight corner, it's just like being in a cinema!

Nicam hi-fi stereo will turn your living-room into a living room of

sound! You don't settle for second best with television picture quality, why settle for second best in television sound quality? Nicam sound is the new high quality digital stereo sound system, pioneered by BBC, ITV and TV/video manufacturers. In fact so good is Nicam it is comparable to the superb sound reproduction of the compact disc, when played through your existing hi-fi arrangement. If your television hasn't got a built-in Nicam decoder, you will need the Maplin Nicam Tuner System. Ultimately almost all of your favourite programmes will be broadcast in superb hi-fi quality stereo-sound! Without a Maplin Nicam Tuner you won't be able to capture every sound to its full.

Nicam hi-fi stereo. Catch your breath, open your eyes, and pin back your ears! It's what your hi-fi system was made for... It's what your ears are made for!

DIGITAL STEREO TV SOUND FROM YOUR HI-FI

The complete kit contains all the components required to build the unit. However you will also need: a power supply, 12V at 600mA regulated e.g. YZ21X at £8.95; a co-ax Y adaptor e.g. FS23A at £1.20; a co-ax lead to connect to your TV or video; RW36P 2m long at £1.28, JW39N 5m long at £1.98, or JW40T 10m long at £2.95; a phono lead to connect to your hi-fi e.g. RWS0E at 98p or a SCART/Peritel lead JW36P at £4.95. An Infra-red remote control kit is also available LP20W at £29.95. Complete kit LP19V only £139.95 incl. VAT + £1 mail-order handling charge.

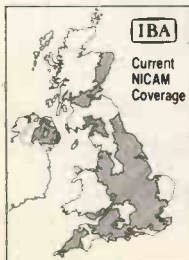

IBA
Current
NICAM
Coverage

Maplin ELECTRONICS

CREDIT CARD HOTLINE
0702 554161

For a friendly welcome and the very best of service why not visit our shops in Birmingham, Brighton, Bristol, Leeds, London (Edgware and Hammersmith), Manchester, Newcastle-upon-Tyne, Nottingham, Reading, Southampton and Southend-on-Sea.

Subject to availability. Prices subject to change.

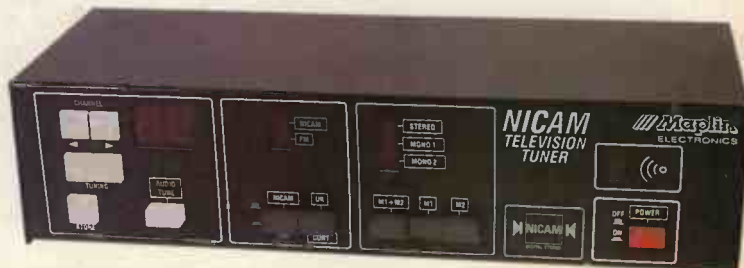

Digital stereo sound companion for your TV set.