

PRACTICAL

SEPTEMBER 1990 • £1.50

ELECTRONICS

SCIENCE AND TECHNOLOGY

TELE-SCOPE

Using your tv as an oscilloscope

DESK THERMOMETER

Coolly gain your degree in Celsius

HOME-BASE

Look what's coming home from Chicago!

BASIC ELECTRONICS

Follow your guide to what's what in electronics



REALISTIC®

Walkie talkies

49 MHz FM
Fully Approved To
DTI Specs MPT-1336

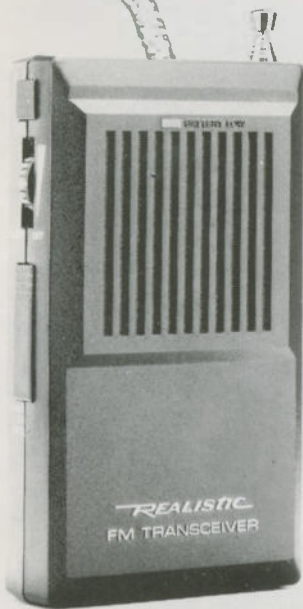

21-401

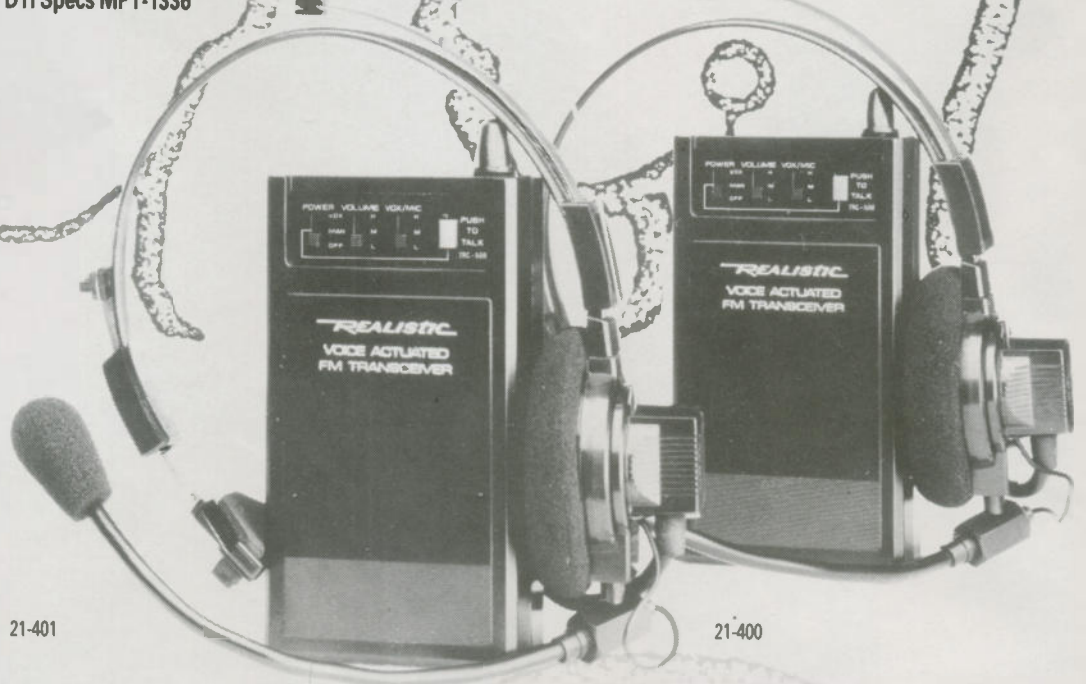

21-400

EACH
£24⁹⁵

• Licence Not Required

Realistic TRC-501. Only 25.4mm thick and five ounces light! Call button transmits a tone signal. Low-battery indicator, push-to-talk button, telescopic aerial. Includes belt clip. Requires one 9v battery.

PAIR
£59⁹⁵

• Licence Not Required

Realistic TRC-500. Voice-actuation gives you hands free communication. Dual-conversion superhets for high sensitivity and clear 2-way communication. Volume switch. With belt clips. Each headset requires 9v battery.

Tandy®

Over 400 Tandy Stores And
Dealerships Nationwide. See
Yellow Pages For Address Of
Store Nearest You.

InterTAN U.K. Ltd., Tandy Centre, Leamore Lane, Walsall, West Midlands. WS2 7PS
Tel: 0922 710000

PRACTICAL ELECTRONICS

VOL 26 NO 9

SEPTEMBER 1990

CONTENTS

CONSTRUCTIONAL PROJECTS



Page 12 ▲

Page 39 ▼

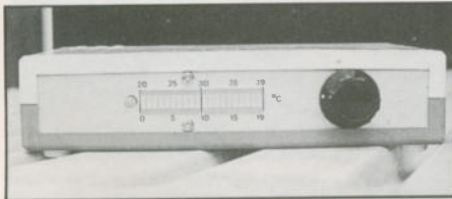

Page 19 ▼



Page 32 ▼



NEXT MONTH

We've just the job for addicts of electronic design, building and testing: a really superb and versatile chip-tester. Our imaginative and unique Tele-Scope will be put into service. There's discussion of a revolutionary technique for futuristic monitoring of domestic gas and electricity reading. And we've a simple voice-operated switch that should really turn you on. Don't miss these or our regular great features.

★ ALL ARE REVEALED IN OUR OCTOBER 1990 ISSUE

★ ON SALE FROM FRIDAY 7TH SEPTEMBER

PE TAKES TECHNOLOGY FURTHER – BE PART OF IT!

PE TELE-SCOPE by John Becker12
Turn your tv into an oscilloscope without tinkering with its innards by building this unique interface module. It's a lower cost way to give your circuits the screen test.

AF OCTAVE MEASURER - PART 2 by Joe Chamberlain23
Detailing the amplifiers and switched filter circuits of the multi-octave audio frequency analyser that's been developed especially for devoted audio designers and repairs.

SCOPE EXPANDER - PART TWO by John Becker35
Testing and putting the finishing touches to the memorable 64K signal sampler that gives your oscilloscope at least eight digital traces.

DESK THERMOMETER by Owen Bishop39
You're sure to give a warm welcome to our easy-to-calibrate modular temperature monitor.

FLASHER ALARM by Paul Benton45
We'll leave the puns to you, this circuit's even more practical and is especially useful to drivers whose indicators excessively go on the blink.

SPECIAL FEATURES

RADIO PAGING by Mike Sanders19
In an overcrowded radio spectrum pagers are economic users of the airwaves and quick bleeps or brief lcd messages are being well received.

HISTORY OF TECHNOLOGY - EDISON by Ian Poole31
Arguably the most prolific inventor ever, Edison set up an invention factory, mass-creating revolutionary innovations. He also discovered the semiconductor effect.

HOME-BASE by Ian Burley32
State-side some possible futures have been displayed at the Summer Consumer Electronics Show in Chicago. We review what could be coming our way.

BASIC ELECTRONICS - PART NINE by Owen Bishop48
We discuss an assorted selection of devices and circuits this month, particularly phototransistors, thyristors and jfets. There are some more modules to build as well.

HOME DATA SYSTEMS by Wayne Green.....52
Our renowned American correspondent enthusiastically considers the potentialities for cd-rom data bases.

REGULAR FEATURES

EDITORIAL by John Becker - Tools for the job9
LEADING EDGE by Barry Fox - Mapping perspective8
SPACEWATCH by Dr Patrick Moore - HST teething troubles46
INDUSTRY NOTEBOOK by Tom Ivall57
NEWS AND MARKETPLACE - what's new in electronics 4
SPECIAL SUBS OFFER - FREE binders for PE subscribers10
BOOKMARK - the Editor's browse through some new books52
ARMCHAIR BOOKSHOP - haven for practical bookworms58
PCB SERVICE - professional PCBs for PE Projects60
HOW TO DO IT - the route to better board building61
ADVERTISERS' INDEX - locating favourite stockists62

TEACHING KITS

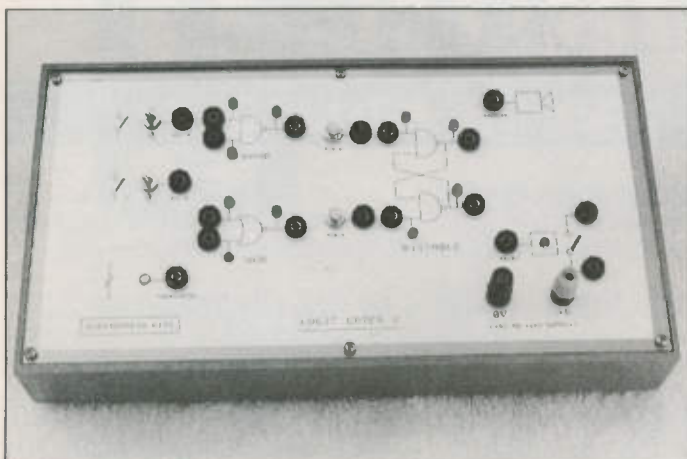

The new National Curriculum stipulates, we are pleased to say, that all secondary school children are to be taught the sciences. In many cases schools will have to consider purchasing more teaching aids to cover the information technology and basic electronics requirements.

To meet the potential demand, Electrotech Kits in conjunction with their local teaching staff have developed a small range of economically priced electronic teaching aids. The initial range of three units includes a basic transistor switch, the logic gates NOT-AND-OR, and the logic gates NAND-NOR plus the bistable.

All units are built into standard sized rugged plastic cases having sloped panels. Transparent perspex front panels present the student with a schematic diagram of the unit's functions. The use of perspex significantly reduces the graffiti that can be written onto the front panel!

Components are contained within

the plastic case to prevent accidental damage from occurring while in use. A standard format has been adopted where input devices are on the left hand side of the front panel, processing functions in the middle, and output devices on the right hand side. 4mm banana sockets are used, with appropriate connecting leads, for the student to interconnect sections of each unit.

All units operate from an external 9V to 12V dc supply. Supply terminals with integral 4mm sockets are fitted to enable the external dc supply to be easily connected to the unit. An internal mains power supply can be fitted on request.

Prices range from £52 to £65 for units purchased in quantities of one to nine, and from £46 to £59 for units purchased in quantities of ten or more.

For more information contact Electrotech Kits, 202 Aylesbury Road, Berton, Aylesbury, Bucks, HP22 5DT. Tel : 0296 28961.

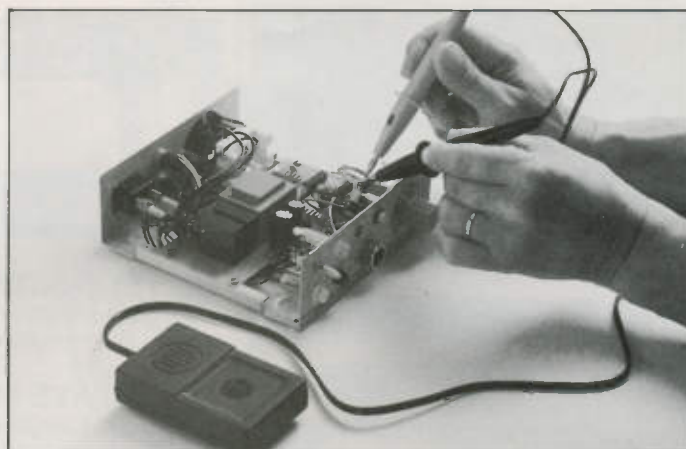

NOISY NOSER

Here's a good idea from Swissinco, a voltage and continuity probe tester which makes noises related to the probed condition. The Cirtest Type 84 incorporates a piezo-ceramic buzzer which emits a variety of tones which are different in frequency and loudness to indicate the test results, thus avoiding the need to visually check readouts whilst making tests.

This high-quality Swiss-made instrument is supplied in a very robust polystyrol casing and meets a variety of safety standards. Voltage protection up to 440V ac and the ability to indicate dangerous voltages are two particular features of what is claimed to be a maintenance-free product.

The probe works from a 4.5V power source, and instrument protection is provided electronically. It is supplied in six versions: resistance; voltages and current; resistance and current; resistance, voltage, current and dangerous voltage; with built-in spot light; for measuring resistance up to 10M; and a version which also features

a switch-on frequency generator (1kHz), as well as a zero ohms comparison switch.

For further information contact Bruce Letchford, Swissinco, Units 1 and 2, Townsend Industrial Estate, Waxlow Road, London NW10 7NU. Tel : 081-965 9505.

CELLULAR POLISH

British Telecom is part of a group bidding for a licence to build and run cellular radio mobile communications service in Poland.

The consortium is led by Swedish Telecom International, part of Televerket, the Swedish PTT, and includes Fintelcom as well as BT.

The group is proposing to provide a service based on NMT, the Nordic Mobile Telephone system which started in Scandinavia in 1981. NMT now has more than 1,100,000 customers in 12 countries in Europe.

CATALOGUE

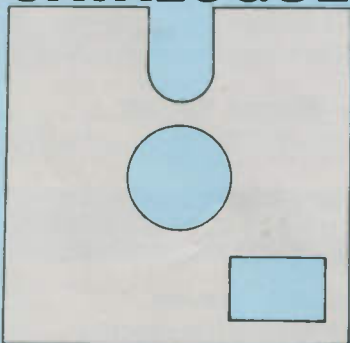

DATABASE

Our browse through recently received literature

Bull Electrical's catalogue and latest newsletter lists a good selection of those bargains for which the company are famous. The catalogue is in a new style, consisting of 30 pages in a handy A5 format, making it easy to read and use. Among the bargains highlighted in the newsletter are tv sound decoders

which enable you to receive sound and video signals straight from a tv aerial, but without using a tv set. Mains fans, mylar cone speakers, and a remarkably low priced led display are featured too. So are mini (24 column) dot matrix printers, for only £10 each. Among the 1000 or so items in the catalogue there are probably many which you would be hard pressed to locate elsewhere, if at all. The catalogue is priced 25p and is well worth obtaining. Bull Electrical, 250 Portland Road, Hove, Sussex, BN3 5QT. Tel 0273 203500. Note this new number, which has several lines on it and replaces the previous system.

Hills Components' catalogue looks as though it is probably of more interest to those who are involved professionally in electronics. We know there are a fair number of PE readers who are in the trade, in many instances running their own small electronics businesses of various types. The catalogue, in over 110 well-illustrated A4 pages, covers the electronic spectrum. Products range from aerial accessories, batteries, cables, connectors and computer hardware, to components, meters, test gear, speakers, tools and transformers. If you are a serious user of electronic products, have a close look through this interesting selection. Hills Components Ltd, Units 5-6, Melinite Industrial Estate, Brixton Road, Watford, Herts, WD2 5SL. Tel 0923 52000.

Babani's catalogue of electronics, radio and computer books should definitely be on your reference shelf. Whether you are wanting to learn about electronics and its allied subjects, or to build even more projects than you already do, you'll undoubtedly find there are many books listed which will help you in these and other aims. It's a nicely illustrated pocket-sized book which lists the titles in subject matter order, with a brief description of each book. Bernard Babani (Publishing) Ltd, The Grampians, Shepherds Bush Road, London W6 7NF. Tel 081-603 2581.

AUDIOPHILE SPEAKERS

Bitstream pioneer Philips has displayed further commitment to audiophile sound with the introduction of a new high quality three-way 150 watt loudspeaker, the FB815.

The quality of this speaker is the result of extensive use of advanced computer design techniques and exhaustive listening tests at Philips' newly equipped sound lab in Dendermonde, Belgium.

Structural integrity was a priority in the design of the 815 which features a 19mm thick high density chipboard cabinet with a 30mm thick baffle.

The three-way system includes an eight inch bass driver and four inch mid range cone with soft coatings and a soft ring mounting. High end reproduction is handled by an 18mm soft dome tweeter manufactured in 'Supronyl' and featuring Philips' developed 'ferrofluid' cooling for high power applications.

Finished in dark walnut, the FB815 is a medium sized speaker measuring 630 x 270 x 270 mm with computer optimised crossover filters and an overload protection system. The speakers come complete with

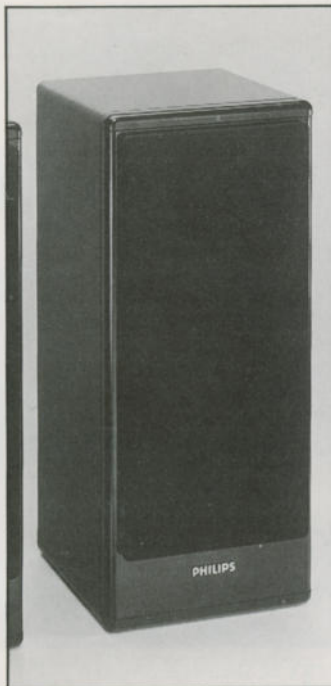

spiked stands and are priced at £229.00.

Ask your local Philips stockist for more details, or speak to Julie Harding at Mathieu Thomas Ltd, 8 Westminster Palace Gardens, Artillery Row, London, SW1P 1RL. Tel 071-222 0833.

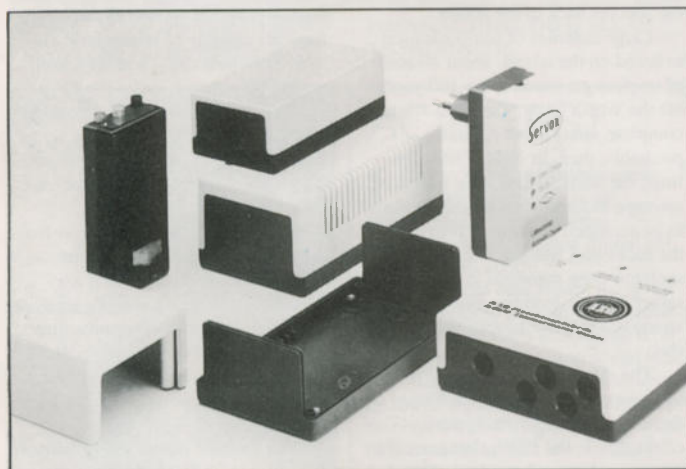

ELEMENTARY DEAR BOPLA

The enclosure known as Element is, according to Bopla, ideal for small instruments and electronic units. Bopla have now made available another version, this time having a mid-grey lower shell, while still maintaining the traditional colours of light grey upper shell and dark grey base.

The enclosure is made from two interlocking sections. It has the advantage that when the upper section is removed, components can be installed quickly and conveniently into the lower section. For mounting a chassis or pcb, threaded brass inserts are provided as standard in the lower

section. The cases are moulded in high-impact polystyrene which is easily drilled or machined if required.

For more information contact Bopla Ltd, 29 Faraday Road, Aylesbury, Bucks, HP19 3RY. Tel : 0296 399999.

EVENTS DIARY

If you are organising any event to do with electronics, big or small, drop us a line, we shall be glad to include it here.

Please note: Some events listed here may be trade or restricted category only. Also, we cannot guarantee complete accuracy of the information, so check details with the organisers before setting out.

Sep 18-21. EFTPOS 90. Exhibition and conference on electronic retailing, Alexandra Palace, London. 0273 722687.

Sep 21-25. IBC Exhibition, Pier Pavilion, Brighton.

Sep 25-27. British Laboratory Week, Olympia, London. 0799 26699.

Oct 2-4. Eurostat 90, Barbican Red Hall, London. 0799 26699.

Oct 20-21. North Wales Radio Rally, Aberconway Centre, Llandudno. 0492 532459, or via callsign GW7EXH.

Nov 6-8. Total Solutions, NEC Birmingham. 0799 26699.

CALLBANK

A new personalised cellular answering and messaging service called Callbank has been launched by Millicom Cellular (UK) Ltd. Millicom says it is the first service provider to offer its own voice messaging system.

Operating on both Cellnet and Vodafone networks, Callbank offers a full range of features and is priced more competitively than other similar services. Two levels of service are currently available with new additions to be introduced throughout this year.

Millicom have also told us of their new hand portable cellular telephone. It has a superior battery life and is one of the smallest and lightest phones on the market.

Millicom's phone, the Kokusai KE101, incorporates a high performance film battery which

dramatically increases operation time. The standard model offers up to 100 minutes 'talk time' in Vox mode and 18 hours standby time. With the optional long life battery, these times are increased up to 250 minutes and 40 hours respectively. The battery is rechargeable.

For further information contact Frankie Delamain, Millicom Cellular (UK) Ltd, South Bank Business Centre, Ponton Road, London SW8 5BL. Tel : 071-757 5000.



Advertisers Awake!

Don't let your competitors steal all the glory of PE News Page Publicity - have YOUR interesting new products highlighted here as well as theirs! Send us concise

details plus a good photo and we'll do our best to publicise them.

First come first served, and it must be interesting. It's up to you to keep us all informed!



BREWING SATCOMS

Three of the yachts which finished the Whitbread Round the World Race used a new Inmarsat satellite communications system throughout the race to keep in touch with their home base and with each other.

Merit, *Gatorade*, and *Equity and Law* were able to keep in constant contact while they raced through the Pacific and Atlantic Oceans using the Inmarsat-C satcoms system.

Inmarsat-C has been available as a pre-operational service for about a year throughout the Atlantic Ocean Region. Since December 1989, a limited test and demonstration capability has also been available in the Pacific Ocean. The system will offer two-way data messaging globally, including telex and data transmission.

Communications from the racing yachts sent via the Inmarsat-C system included position reports, communications with other yachts in the race and status reports back to their base stations. In one case, details of a yacht's technical difficulties were called ahead to the next port so that the

spare parts they needed were waiting when the yacht arrived. The central base station in Southampton that monitored the entire race also relied on regular reports from the satcom-fitted yachts for up-to-the-minute status reports on the progress of the race.

According to Antonio Chiotto of Europ Assistance, one of *Merit* and *Gatorade's* sponsors, "satellite communications were absolutely indispensable to keep our operations centre in constant contact with the crews. Satcoms allowed us to give critical assistance to solve various technical and medical problems that arose during the race."

Inmarsat, with 59 member country investors, operates a global system of eight satellites to provide mobile communications for maritime, aeronautical and land mobile customers worldwide.

For further information contact Elizabeth Hess, Inmarsat, 40 Melton Street, London NW1 2EQ. Tel : 071-387 9089.

YOUNG WOMAN ENGINEER AWARD

With more young women forging ahead in the engineering industry, it is anticipated that the standard of competitors will be exceptionally high for this year's coveted Young Woman Engineer of the Year Award, now in its thirteenth year.

Nominations, from suitably qualified young women under the age of 30, are invited by the Institution of Electronics and Electrical Incorporated Engineers (IEEIE), and should be submitted by 1st October 1990.

Having successfully completed the necessary technical education and training, all entrants will be required to prove themselves capable of holding a responsible position at Incorporated Engineer level.

The aim of the Award, sponsored jointly by the IEEIE and the Caroline Haslett Memorial Trust (CHMT), is to highlight the exciting career prospects available for women in electronic and electrical engineering.

In addition to gaining prestige associated with the Award, the 1990 Young Woman Engineer of the Year will receive a silver rose bowl and a prize of £500. The most promising younger entrant will receive the CHMT's Mary George Memorial prize of £100.

Copies of the Award nomination form and brochure are available from The Secretary, IEEIE, Savoy Hill House, Savoy Hill, London WC2R 0BS. Tel : 071-836 3357.

BUCCANEERING WILD LIFE



The Shearwater Project is Dyfed Wildlife Trust's attempt to re-introduce a colony of Manx Shearwater birds to Cardigan Island. A vital part in the project is being played by AF Bulgin's tough waterproof Buccaneer cable connectors. The products are being used to connect up a solar-powered sound system, broadcasting the bird's calls, which experts hope will attract the species back to the island.

Large colonies of sea-birds used to breed on the island, about 40 acres of treeless grassland lying 300 yards off the Welsh coast. The birds were in complete safety from natural predators, then, in 1934 a 7000 ton liner, the SS Herefordshire, parted her towrope in rough seas whilst on route to be scrapped and was driven onto the rocks on Cardigan Island. Her skeleton crew managed to reach the safety of the island but, unfortunately, so too did the rats leaving the doomed ship.

The rats totally exterminated the shearwaters, and also the puffins there too. The rats in turn were eradicated in the 1960s, but even after 25 years of natural recolonisation, neither shearwaters nor puffins have returned to the island.

In an attempt to redress the

situation, the island's management committee are experimentally using sound recordings to create an audible impression of an established colony.

A wide range of industries not normally involved in conservation have become interested in the project, supplying equipment and carrying out research on the Trust's behalf. The resulting sound broadcasting equipment comprises a sophisticated stand-alone solar powered static ram recorder capable of broadcasting up to 55W of bird call, switching itself on and off automatically. It was designed to operate unattended even in severe maritime weather for up to five years with minimal maintenance. Its amplifier is installed in a die-cast aluminium case and the Trust, recognising that the connections from the case to the rest of the equipment would have to be waterproof and rugged, asked the advice of specialist electronic component manufacturers, AF Bulgin. The company donated 22 Buccaneer connectors to the project, enough for the main system, its back-up recorder and amplifier.

For further information contact A.F. Bulgin & Co PLC, Bypass Road, Barking, Essex, IG11 0AZ. Tel : 081-594 5588.

MR SEMICONDUCTOR DIES AT 62

Dr. Robert Noyce, the co-inventor of the integrated circuit died at his home in Texas at the beginning of June.

Affectionately known by his colleagues in Silicon Valley as 'Mr Semiconductor', Dr Noyce played a vital role in the development of the world-wide semiconductor industry. He was a co-founder of Fairchild in

1957, and helped to set up Intel, of which he was still vice-chairman at the time of his death. For the last two years of his life he also spent much time working as chief executive of Sematech, the American semiconductor research consortium.

Dr Noyce was 62 and died from a heart attack.



TRANSATLANTIC BRAIN SWAP

Micro Devices feel that "for the first time in the UK, designers can get hands-on experience with the latest advances in hardware Digital Neural Network (DNN) technology". The company, based in Florida, has signed an agreement with the English-based company Tubb Research, allowing them to provide full sales and engineering assistance for a range of ics which utilise 'brain-like' neural networks.

The ics have been designed to make very fast comparisons and decisions on real world data. One low cost chip can provide the

performance of a 25 MIPS processor! Programming is eliminated because the network is trained.

By experimenting with this leading-edge technology, the UK designer can at last incorporate DNN into a vast range of products, to add 'learning' and 'intelligence', from office equipment to financial market analysis, from defence and space equipment, to robots and cars.

For further information contact Tubb Research Ltd, 7a Lavant Street, Petersfield, Hants. GU32 3EL. Tel : 0730 60256.

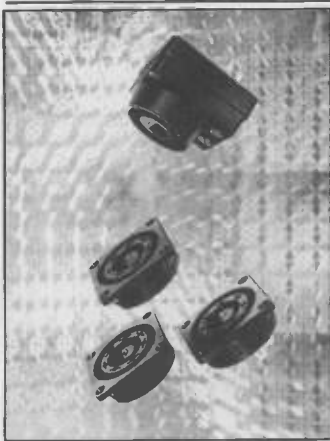

8 TO THE BAR

With more and more users of disco lighting systems turning to printed circuit board control, Bulgin have added a panel mounting connector with pc spills to their widely used Disco 8 family of connectors.

The new model PX0552/PC is an eight pole connector moulded from glass filled nylon, with a maximum rating per pin of 6A 250V ac. Its mouldings are polarised to prevent accidental misconnection.

For more information contact A.F. Bulgin & Co PLC, Bypass Road, Barking, Essex, IG11 0AZ. Tel : 081-594 5588.

ACID TEST

Litmus paper yet again seems further threatened as an endangered species with the introduction of ET's new digital pH meter, model 8000.

It is a hand held meter, using the latest electronic technology to make it simple to use and to measure 0.00 to 14.00 pH with an accuracy of 0.02 pH. All measurements are displayed on the 12.5 mm high liquid crystal display, which incorporates the mode of measurement and low battery indication.

For more information contact Mrs D. Prior at Electronic Temperature Instruments Ltd, 52 Broadwater Street East, Worthing, West Sussex, BN14 9AW. Tel : 0903 202151.



CHIP COUNT

MEGACELL MICROS

The powerful ST6 family of HCMOS single chip microcontrollers is now available from Impulse.

Manufactured in a proprietary low power HCMOS process by SGS/Thomson, the ST6 family comprises a range of applications-orientated microcontrollers. The 8-bit architecture of the range features a simple instruction set, and includes the ability to perform 16-bit manipulation. (The data we received actually says "1-bit" but we're pretty sure it means 16-bit!) A wide range of operating voltages from 2V to 6V is supported, and clock speeds can be up to 8MHz.

This family features a 'Megacell' modular approach to its specifications, meeting a wide range of applications requirements. Thus a core cpu can be complemented with a choice of memory sizes and an extensive variety of i/o and peripheral options. These include adcs, serial i/o, 16 and 8-bit counter/timers, DTMF generation, watchdog systems, lcd devices and so on. A range of standard configurations is available from Impulse.

Memory options include rom sizes of up to 8K bytes coupled with ram sizes of 64, 128 or 256 bytes. Versions using eeprom for program memory are also available.

PC383C562 MICROCONTROLLER

The new PC383C562 cmos controller from Philips is an 80C51-based type with all the extra functions needed to enable it to control a variety of advanced consumer equipment such as satellite tv, video recorders and high-end cd players. The 'extras' include an 8-bit adc, a dual dac with pulse-width modulated outputs to drive stepper motors and another 16-bit timer/counter.

The basic elements of the chip are 8K bytes mask programmed rom, and 256 bytes of ram. Both are expandable off-chip to 64K bytes. A full duplex UART serial interface and five i/o ports are included.

In addition to the standard features of the 80C51, the new microcontroller has an extra 16-bit counter/timer (coupled to three compare and four capture registers), a 16-bit watchdog timer and an idle and power-down modes for low power operation.

The extra 16-bit time/counter makes the device well suited for applications such as automatic tuning. The on-chip 8-bit adc can be used to track parameters such as battery voltage or the position of a cd player's laser.

NE8392A TRANSCEIVER

Philips has just released a new transceiver, the NE8392A, for use in the interface chip sets for Ethernet and Cheapernet (Thin Ethernet) local area networks (LANS).

The transceiver is connected between the coaxial cable of the LAN and the data terminal equipment (via isolation circuits). The data terminal ics are available from other sources.

The device consists of a receiver, transmitter, collision detector, heartbeat generator and jabber timer. During transmission the jabber timer is initiated to disable the transceiver in the event of a 'longer than legal length' data packet. Collision detection circuitry monitors the signals on the coax cable. At the end of every transmission the heartbeat generator creates a pseudo-collision for a short time to ensure that the collision circuitry is functioning correctly. (Own up, how many of you thought the chip had medical applications?!)

MANUFACTURER'S ADDRESS

Impulse Electronics, Hammond House, Caterham, Surrey, CR3 6XG. Tel : 0883 46433.

Philips Components Ltd, Mullard House, Torrington Place, London WC1E 7HD. Tel : 071-580 6633.

The Department of Photogrammetry at University College London has for four years been working with British companies Thorn EMI and LaserScan of Cambridge on a technique of generating three dimensional maps from two dimensional pictures. Not surprisingly the military is in on the act. The Royal Signals and Radar Establishment at Malvern helped with the research, and the Ministry of Defence chipped in with £0.9 million on top of £1.6 million from the British Government.

UNDER-MAPPED

Essentially the system is a computer which builds three dimensional images of the earth's surface from pictures snapped by satellite. The project is part of the Alvey programme. Indeed, project leader Peter Muller of UCL says it is "the only Alvey project with a commercial future".

"The surface of the earth is appallingly badly mapped," says Muller. "There are no maps at all for large areas of Africa and Asia".

LEADING

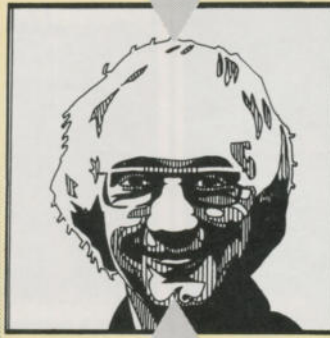

EDGE

ground. By working in parallel, the transputers can process around 200 picture points per second and build a full image in a few hours, compared to a fortnight per image with previous systems.

The same technology can be used to produce terrain models for mineral exploration, give patients a preview of what they will look like after facial surgery and predict earthquakes by pin-pointing strains in the earth's surface. The first commercial use will be to map volcanoes in Siberia.

FUZZY LOGIC

In Japan there has been a lot of talk recently about gadgetry that relies on "fuzzy logic". This is a way of writing computer programs so that they can cope with fuzzy information like "maybe it does this" and "probably it does that" and "perhaps it would go there". Normally computers deal only in the hard facts "yes" or "no". Fuzzy logic helps military systems decide, on balance, whom to attack. It helps

MAPPING PERSPECTIVE

OVER-JARGONED

The press got a private briefing ahead of the University's Chancellor H.R.H. The Princess Royal. Although UCL had been smart and employed a PR agency to try and translate the technology into something halfway to understandable English, I did still wonder what on earth HRH made of the bump she was given.

"Note the dense haze and jet contrails on the left image in a Lambert Zone-3 map projection ... image displayed in the UCL Dynamic Visualisation Toolkit program, DISP, on a Sun graphics work station ... an orthographically projected image is first created ... a planimetric flight path is first hand drawn as a wireframe view ... the first data-sets created will be global topography ... using the UK Along-Track Scanning Radiometer..." and so on and on and on.

Who says the royal family don't earn their living?

It reminded me of the way Dennis Thatcher manages to look interested when obliged to follow wife Margaret round the latest Japanese factory in Britain to mass-produce widgets.

"Oh look", he says. "There goes another one, just like the last one."

SPOT-LITE

The UCL system is actually very clever, once you get past the jargon. UCL has been working with pictures of the Earth received from the French Spot satellite, which orbits the earth at an altitude of 840km. Spot's

BY BARRY FOX
Winner of the
UK Technology Award

**Although
cartographers
welcome hi-d global
cartography, will the
rest of us be over
the moon with fuzzy
auto-focus?**

camera has a strip of 6000 solid state light sensors which scan the image line by line, in a raster of 6000 lines, like a very high definition tv camera.

To provide the information needed for 3-D analysis, the camera looks at the earth through a mirror which can be tilted by 27 degrees either way. On one pass over a selected area on the ground the mirror is tilted one way. On another pass over the same area, weeks, months or even years later, the mirror is tilted in the opposite direction. This provides two pictures of the same terrain, taken at a difference angle of 54 degrees. UCL uses a gang of 32 transputers, working in parallel, to compare the picture pairs, identify identical objects and deduce their height from the different perspectives. The computer then either generates a three dimensional image on a tv screen or adds colour to a flat paper image to signify height above sea level. The system is accurate to 10 metres on the

computers fly planes. The Japanese are now trying it on consumer electronics equipment and the first publicity push is from Sanyo. The company recently unveiled a new camcorder with fuzzy logic in Japan, the US and Europe.

The theory makes some sense. The auto-focus and auto-iris exposure electronics take a lot of fine readings instead of a few coarse ones, and then follow a set of rules on how to interpret the results and adjust the camera. But the camera is only as good as its rules. It can't do what humans do and mentally over-ride visual cues - like listening to someone behind you at a cocktail party. Sanyo's focus system has 21 rules. The crunch question is how they cope with well known auto-focus crackers, like a white shirt seen through wire netting or someone in the audience walking in front of a telephoto shot of a band on stage.

OUT-FOXED

I wish I could tell you the good news that fuzzy logic beats these crackers. But, with what may sound to some like somewhat fuzzy logic, Sanyo UK wouldn't let me go to their demonstration of this interesting new technology because I have in the past referred in print to Sanyo UK's failure to communicate on interesting new technology.

However well the camera does or does not cope with difficult scenes, is it really wise for Sanyo (both in Europe and the USA) to boast the feature "Fuzzy Auto Focus"? For most punters, the last thing an auto-focus system should be is fuzzy. **PE**

Man is a tool-using animal ... without tools he is nothing, with tools he is all.

So pronounced Thomas Carlisle sometime during the 19th Century, at a time when technology was, on an immense and glorious scale, making its impact felt on society.

We, at the end of the 20th Century, think our technology and accomplishments are incredible, that the tools we have today can achieve more than any of those invented by our predecessors. But is it necessarily so? It's a matter of perspective, and how you define the achievements wrought with the aid of tools. Had we lived a hundred years ago, our wonder at the marvels being worked around us and by us would surely have been no less than we experience today.

With interest, I have been following the progress of the Channel Tunnel. I've visited the Shakespeare Cliff site a few times and once the press waiting list shortens hope to tour the tunnel itself. The giant borer and its associated machinery are impressive examples of the precision to which we are capable of working with tools on a grand scale. The lasers and computers used to guide the cutting show our tooling capabilities at the other end of the scale. That we can manipulate electrons and photons is indeed a modern miracle. And yet, the Victorians believed that they also could put a tunnel under the Channel.

PRACTICAL ELECTRONICS



TOOLS FOR THE JOB

It's sometimes a mistake to think that today's tools are the only ones which could do the job. You've only got to look at the great railway tunnels built by the Victorians. They rightly had faith that they possessed the tools with a Chunnelling ability. It was only politics that prevented them from achieving it.

But *possessed the tools* is the key phrase. It's usually nonsense to attempt a job without the right tools. At times you may be lucky: you may find that a coin in your pocket is simply a screwdriver in disguise, or that your teeth really grew up to be bottle openers. But don't count on it. You won't

always find that imaginative thinking can metamorphose mundane objects into the tools you need. You may come a cropper because you haven't given full thought to the implications of attempting something for which you may be ill-prepared.

A handful of readers found themselves in this predicament over the *Eprom Poly-Programmer*. They had read part one in *PE* May 90 and enthusiastically rushed out to buy the components. Very commendable! Except that they should have waited for part two in June so that they could better assess whether they had the tools for the job. Regrettably, they hadn't. The *Eprom Poly-Programmer* is a sophisticated device which is partly controlled by its own eprom. That eprom needs to be programmed on another programmer. These few unfortunate readers found themselves in a Catch-22 situation: they wanted a programmer but hadn't a programmer to program it!

So I chatted with Kevin Browne, the project's designer. Very kindly, he agreed to program readers' eproms for the project in return for a very nominal donation towards his expenses. Problem solved - he has the tools.

But take heed, however enthusiastic you are, before you start a job make sure you know what's involved *and that you've got the tools for it.*

THE EDITOR

Editor:

John Becker

Sub-Editor:

Helen Armstrong

Technical Illustrator:

Derek Gooding

Group Advertisement Manager:

Jacqueline Barlow

Advertisement Executive:

David Bonner

Production Editor:

Richard Milner

Office Manager:

Tim Lyster

Office Secretary:

Wendy Rhodes

Publisher:

Angelo Zgorelec

Practical Electronics,
Intra House, 193 Uxbridge Road,
London W12 9RA
Tel: 081-743 8888
Telecom Gold: 87: SQQ567
Fax: 081-743 3062

Readers' Enquiries

All editorial correspondence should be addressed to the editor and any letters requiring a reply should be accompanied by a stamped addressed envelope, or equivalent payment.

We regret that lengthy technical enquiries cannot be answered over the phone.

Advertisements

The Publishers of PE take reasonable precautions to ensure that advertisements published in the magazine are genuine, but we cannot take any responsibility in respect of statements or claims made by advertisers. The Publishers also cannot accept any liability in respect of goods not being delivered or not working properly.

© Intra Press 1990. Copyright in all drawings, photographs and articles published in PRACTICAL ELECTRONICS is fully protected, and reproduction or imitations in whole or in part are expressly forbidden. All reasonable precautions are taken by PRACTICAL ELECTRONICS to ensure that the advice and data given to readers is reliable. We cannot, however, guarantee it, and we cannot accept legal responsibility for it. Prices quoted are those current as we go to press. All material is accepted for publication on the express understanding that the contributor has the authority to permit us to do so. ISSN 0032-6372

PE Services

SUBSCRIPTIONS - Annual subscription rates are £18.00 for the U.K. or £21.00 overseas (Air mail overseas is £39.00). Please send your cheques (payable to Intra Press), payment by Visa or Access also accepted, to: Practical Electronics, Subscription Dept., P.O. Box 500, Leicester LE99 0AA. Telephone: 0858 410510 (ask for Practical Electronics Subscriptions).

BACK ISSUES - We still have a limited number of the back issues from the last three years available (Certain issues from earlier years are also available, but check before ordering). Price £1.75 - overseas £2.25 (inclusive of postage). Orders should be sent to our editorial address.

BINDERS - to hold 12 issues of PE are also available from our editorial address. Price £5.95 (overseas £6.95 - surface mail). Post included.

BOOK SERVICE - see the Book Service advertisement in the magazine.

PCB SERVICE - details inside.

Cover Photo:
Ed Davis

SPECIAL SUBS OFFER!

SUBSCRIBE AND BE GIFTED!

TAKE OUT 12 MONTHS' SUBSCRIPTION TO PE AND CHOOSE A GIFT:

★ A FREE BINDER TO HOLD 12 COPIES OF PE WORTH £5.95

OR

★ A FREE 300 PAGE BOOK "INTERNATIONAL TRANSISTOR EQUIVALENTS GUIDE" WORTH £3.95

EXTRA SPECIAL OFFER TO STUDENTS, TEACHERS AND BAEC* MEMBERS SAVE 10% AND RECEIVE THE GIFT OF YOUR CHOICE!

(*British Amateur Electronics Club)



If you already subscribe to PE you can take advantage of this special offer by extending your existing subscription - please advise your current subscription number or say from which month you want your subs to run.

Yes please PE, put me on course to a hi-tech future: Enrol me on your priority subscription list and send me 12 issues and my free gift for the following special price:

UK readers

£18

£16.20 (student/teacher/BAEC)

Overseas Readers

£22

£19.80 (student/teacher/BAEC)

Proof of my student/teacher/BAEC status is attached (e.g. headed notepaper etc.).

I wish my subs to start from the earliest possible issue

I wish to extend my existing subscription for a further 12 months commencing with the issue dated

As my free gift I would like to receive:

The Binder

The Transistor Equivalents Guide

Please send my monthly copy of PE to:

Name and address

.....

.....

Post Code

I enclose a cheque / postal order

Please charge to my Access / Visa card number

Send this form (or a photocopy of it) to:
Practical Electronics Subscriptions, 193
Uxbridge Road, London W12 9RA

COMPUTER ICs

80C31 MICRO	£2
P8749H MICRO	£5
BBC MICRO PARTS	
SN76489AN	£3
VIDEO ULA 201647	£10ea 10+ £8
6845 CRT	£5
6522 PIA	£3
DM88LS120	£4.50
AY3-10150 UART	£2.50
8086 processor ex-equipment	£2
USED 41256-15	£1.50
USED 4164-15 ex-equipment	£1
9 x 41256-15 SIMM MODULE NEW	£10
8 x 4164 SIP MODULE NEW	£8
HD 146818 CLOCK IC	£2
2864 EEPROM	£3
27128A 250ns EPROM USED	£2 NEW £2.30
FLOPPY DISC CONTROLLER CHIPS 1772	£16 ea
68000-8 PROCESSOR NEW	£5
HD63484-8	£5
ALL USED EPROMS ERASED AND BLANK CHECKED CAN BE PROGRAMMED IF DESIRED.	
2716-45 USED	£2 100/£1
2732-45 USED	£2 100/£1
2764-30 USED	£2 100/£1.60
27C256-30 USED	£2
27C512 USED (ALSO 27512)	£3.00
1702 EPROM EX EQPT	£5
2114 EX EQPT 60p 4116 EX EQPT	70p
6264-128k static ram	£3.00
62256-12 32K static Ram	£7.00
2532 EPROM USED	£2
4416 RAM	£3.00
USED 4416-15 RAM	£2
USED 41464-15	£5

REGULATORS

LM317T PLASTIC TO220 variable	£1
LM317 METAL	£2.20
7812 METAL 12V 1A	£1
7805/12/15/24V plastic	38p 100+20p 1000+ 18p
7905/12/15/24 plastic	38p 100+20p 1000+ 18p
CA3085 TO99 variable reg	2/£1
LM338 5A VARIABLE	£5

CRYSTAL OSCILLATOR

1.8342 £1 each 1M, 1.8432M, 4M, 16M	£1.50 each
CRYSTALS	
2.77 MHz/4.000 MHz/4.9152MHz 20MHz 49.504MHz, 8M, 16.568M	£1 each

TRANSISTORS

BC107, BCY70 PREFORMED LEADS	
full spec	£1 £4/100 £30/1000
BC557, BC548B, BC238C, BC308B	30/£1 £3.50/100

POWER TRANSISTORS

N POWER FET IRF531	3/£1
P POWER FET IRF531	2/£1
2SC1520 sim BF259	3/£1 100/£22
TIP141/2 £1 ea TIP112/125/42B	2/£1
TIP35B TIP35C	£1.50
SE9301 100V 10A DARL. SIM TIP121	2/£1
2N3055 EX EQPT TESTED	4/£1
PLASTIC 3055 OR 2955 equiv 50p	100/£38
2N3773 NPN 25A 160V £1.80	10/£16

QUARTZ HALOGEN LAMPS

A1/216 24V 150 WATTS	£2.28
H1 12V 50W (CAR SPOT)	£1.60
14 WAY ZIF S/KT	£1
TEXTTOOL single in line 32 way. Can be ganged (coupling supplied) for use with any dual in line devices.	2/£2
28 WAY TEXTTOOL ZIF SOCKET EX NEW EQUIPMENT	£2.50

CAPACITORS COMPUTER GRADE

3300uF 350V SIC SAFCO FELSIC 037	£4(£1.50)
2200uF 160V SIC SAFCO FELSIC C038	£4(£1.20)
24,000uF 50V	£3 (1.30)

TURNS COUNTING DIALS

10 turn dial 21 mm dia. fits 3mm spindle	£2
10 turn digital dial (3 digits) for 3mm or 6mm shaft	£3.50
10 turn clock face dial for 6mm spindle	£4

MISCELLANEOUS

MAINS ADAPTOR 9V DC 200mA	£1.25
SLOPING FRONT PLASTIC CASE 225 x 215 x 76mm	
76mm WITH ALL FRONT PANEL 200 x 130mm	£3.30
HUMIDITY SWITCH ADJUSTABLE	£2
WIRE ENDED FUSES 0.25A	30/£1
NEW ULTRASONIC TRANSDUCERS 40kHz	£2/pair
12 CORE CABLE 7.0.2mm OVERALL SCREEN	70p/METRE
OP AMP LM10CLN	£2.90
BNC 50 OHM SCREENED CHASSIS SOCKET	3/£1
BNC TO CROC CLIPS LEAD 1 metre	£1
LEMAGE EARTH LEAKAGE TRIP 35A 30mA trip	£9.00
AMERICAN CHASSIS 2/3 pin SOCKET	2/£1
USED 3 1/2" FLOPPY DISCS D/S 720K	50p 10/£4
TO-220 HEAT SINK sim RS 403-162	10/£2.50
SMALL MICROWAVE DIODES AEI DC1028A	2/£1

D.I.L. SWITCHES 10 WAY £1 8 WAY 80p 4/5/6 WAY	80p
180 volt 1 watt ZENERS also 12v & 75v	20/£1
VN10LM 60V 1/2A 50hm TO-92 mostlet	4/£1 100/£20
MIN GLASS NEONS	10/£1
MINIATURE CO-AX FREE PLUG RS 456-071	2/£1
MINIATURE CO-AX FREE SKT. RS 456-273	2/£1.50
DIL REED RELAY 2 POLE n/o CONTACTS	£1
PCB WITH 2N2646 UNIJUNCTION with 12v 4 POLE RELAY	£1
400m 0.5w thick film resistors (yes four hundred megohms)	4/£1
STRAIN GAUGES 40 ohm Foil type polyester backed balco grid alloy	£1.50 ea 10+ £1
ELECTRET MICROPHONE INSERT	£0.90
Linear Hall effect IC Micro Switch no 613 SS4 sim RS 304-267	£2.50 100+ £1.50
HALL EFFECT IC UGS3040 + MAGNET	£1
OSCILLOSCOPE PROBE SWITCHED X1 X10	£10
CHEAP PHONO PLUGS	100/£2 1000/£18
1 pole 12 way rotary switch	4/£1
AUDIO ICs LM380 LM386	£1 ea LM324
555 TIMER 5/£1 741 OP AMP	5/£1
ZN414 AM RADIO CHIP	80p
COAX PLUGS nice ones	4/£1
COAX BACK TO BACK JOINERS	3/£1
4 x 4 MEMBRANE KEYBOARD	£1.50
15,000uF 40V	£2.50 (£1.25)
INDUCTOR 20uH 1.5A	5/£1
1.25" PANEL FUSEHOLDERS	3/£1
CHROMED STEEL HINGES 14.5 x 1" OPEN	£1 each
12v 1.2w small wire ended lamps fit AUDI VW TR7 SAAB VOLVO	10/£1
12V MES LAMPS	10/£1
STEREO CASSETTE HEAD	£2
MONO CASS HEAD £1 ERASE HEAD	50p
THERMAL CUT OUTS 50 77 85 120°C	£1 ea
THERMAL FUSE 121°C 240V 15A 220°C	5/£1
TRANSISTOR MOUNTING PADS TO-5/TO-18	£3/1000
TO-3 TRANSISTOR COVERS	10/£1
STICK ON CABINET FEET	30/£1
PCB PINS FIT 0.1" VERO	200/£1
TO-220 micas + bushes	10/50p 100/£2
TO-3 micas + bushes	15/£1
PTFE min screened cable	10m/£1
Large heat shrink sleeving pack	£2
CERAMIC FILTERS 6M/9M/10.7M	50p 100/£20
1eC chassis plug rfi filter 10A	£3
potentiometers short spindles values 2k5 10k 25k 1m	
2M5 lin	5/£1
500k lin 500k log	4/£1
40kHz ULTRASONIC TRANSDUCERS EX-EQPT NO DATA	
OMRON 12V G2V DIL RELAY 2 POLE CHANGEOVER	2/£1
SCART CONVERTOR	£1
BZY48C12 WIRE ENDED 12V 7WATT ZENER 17K STOCK	5/£1
3M/SCOTCHFLEX 50 WAY ROUND JACKETED FLAT CABLE 3659/50 (50 WAY IDC RIBBON WITH FOIL AND BRAID SCREENS, ROUND SECTION WITH BLACK PVC OUTER) £1. METRE, 100' REEL	£65 (£1.50)
FANS 240V 120mm (OTHER VOLTAGE/SIZES USUALLY AVAILABLE)	£6 (1.50)
MOULDED INDUCTOR 470UH SIZE OF 1W RES	8/£1

DIODES AND RECTIFIERS

1N4148	100/£1.50
1N4004/S04 1A 300V	100/£3
1N5401 3A 100V	10/£1
BA158 1A 400V fast recovery	100/£3
BA159 1A 1000V fast recovery	100/£4
120V 35A 22UD	65p
BY127 1200V 1.2A	10/£1
BY254 800V 3A	8/£1
BY255 1300V 3A	6/£1
6A 100V SIMILAR MR751	4/£1
1A 800V BRIDGE RECTIFIER	4/£1
4A 100V BRIDGE	3/£1
6A 100V BRIDGE	2/£1
8A 200V BRIDGE	2/£1.35
10A 200V BRIDGE	£1.50
25A 200V BRIDGE £2	10/£18
25A 400V BRIDGE £2.50	10/£22

SCRs

PULSE TRANSFORMERS 1.1+1	£1.25
2P4M EQUIV C106D	3/£1
MCR72-6 10A 600V SCR	£1
35A 600V STUD SCR	£2
TICV106D 800mA 400V SCR	3/£1 100/£15
MEU21 PROG. UNIJUNCTION	3/£1

TRIACS

BT 137-600 8A TO-220	2/£1
BT138-600 12A TO-220	70p
MEU21 PROG. UNIJUNCTION	3/£1
NEC TRIAC AC08F 8A 600V TO220	5/£2 100/£30
TXAL225 8A 400V 5mA GATE 2/	£1 100/£35
3TA08-400 8A 400V 5mA GATE ISOL TAB	£1
CA3059 0 VOLTAGE SWITCH	£1 each

DIACS 4/£1

CONNECTORS

D25 IDC SOCKET FJITSU	£2
34 way card edge IDC CONNECTOR (disk drive type)	£1.25
CENTRONICS 36 WAY IDC PLUG	£2.80
CENTRONICS 36 WAY IDC SKT	£4.00
BBC TO CENTRONICS PRINTER LEAD 1.5M	£3.00
CENTRONICS 36 WAY PLUG SOLDER TYPE	£4
USED CENTRONICS 36W PLUG+SKT	£3

USED D CONNECTORS price per pair

D9 60p, D15 £1.50, D25 £2, D37 £2, D50 £3.50 covers 80p ea.	
WIRE WOUND RESISTORS	
W21 or sim 2.5W 10 of one value	£1
R10 OR15 OR22 2R0 4R7 5R0 5R6 8R2 10R 12R 15R 18R 20R 22R 27R 33R 47R 56R 62R 91R 120R 180R 390R 430R 470R 680R 820R 910R 1K15 1K2 1K5 1K8 2K4 2K7 3K3 3K0 5K0	4 FOR £1

W22 or sim 6W 7 OF ONE VALUE	£1
R47 R62 1R0 1R5 1R8 3R3 6R8 9R1 12R 20R 24R 27R 33R 51R 56R 62R 68R 100R 120R 180R 220R 390R 560R 620R 910R 1K0 1K2 1K5 1K8 2K2 2K7 3K3 3K9 4K7 8K2 10k 15K 16K 20K	£1
W23 or sim 9W 8 of one value	£1
R22 R47 1R0 1R1 56R 62R 100R 120R 180R 220R 300R 390R 680R 1K0 1K5 5K1 10K	£1
W24 or sim 12W 4 OF ONE VALUE	£1
R50 2R0 9R1 18R 22R 27R 56R 68R 75R 82R 100R 150R 180R 200R 220R 270R 400R 620R 1K0 6K8 8K2 10K 15K	£1

PHOTO DEVICES

SLOTTED OPTO-SWITCH OPCOA OPB815	£1.30
2N5777	50p
TIL81 PHOTO TRANSISTOR	£1
TIL38 INFRA RED LED	5/£1
4N25, OP12252 OPTO ISOLATOR	50p
PHOTO DIODE 50p	6/£2
MEL12 (PHOTO DARLINGTON BASE n/c)	50p
4 DIGIT LED 7 SEG. DL4770	£1
LEDs RED 3 or 5mm 12/£1	100/£8
LEDs GREEN OR YELLOW 10/£1	100/£6.50
LEDs ASSORTED RD/GN/YW + INFRA/RED	200/£5
FLASHING RED OR GREEN LED 5mm 50p	100/£40
HI BRIGHTNESS LEDS C0X24 RED	5/£1

STC NTC BEAD THERMISTORS

G22 220R, G13 1K, G23 2K, G24 20K, G54 50K, G25 200K, RES @ 20°C DIRECTLY HEATED TYPE	£1 ea
F822W NTC BEAD INSIDE END OF 1" GLASS PROBE @ 20°C 200R	£1 ea
A13 DIRECTLY HEATED BEAD THERMISTOR 1k res. Ideal for audio Wien Bridge Oscillator	£2 ea

CERMET MULTI TURN PRESETS 3/4"

10R 20R 100R 200R 250R 500R 2K 2K2 2K5 5K 10K 47K 50K 100K 200K 500K 2M	100/£4 each
---	-------------

IC SOCKETS

6 pin 15/£1 8 pin 12/£1 14/16 pin 10/£1 18/20 pin 7/£1, 22/24/28 pin 4/£1 40 pin 30p	
--	--

SOLID STATE RELAYS

40A 250V AC SOLID STATE RELAYS	£18
--------------------------------	-----

POLYESTER/POLYCARB CAPS

100n, 220n, 63v 5mm	20/£1 100/£3	
1n/3n/5n/6n/8n/210n 1% 63v 10mm	100/£6	
10n/15n/22n/33n/47n/68n 10mm rad	100/£3.50	
100n 250v radial 10mm	100/£3	
100n 600v sprague axial 10/£1	100/£8 (£1)	
2u2 160v RAD 22UD	2u2 100v RAD 15mm	100/£10
10n/33n/47n 250v ac x rated 15mm	10/£1	
470n 250v ac x rated rad	4/£1	
1U 600V MIXED DIELECTRIC	50p ea.	
1u0 100v RAD 15mm, 1u0 220v RAD	£8/100	
2U2 250V PMT CAPS. STOCK 6K	£20/100	

RF BITS

MINIATURE CO-AX 50Ω URM95	100m/£12
TRIMMER CAPS ALL	4/50p
SMALL 5pl 2 pin mounting 5mm centres	
SMALL MULLARD 2 to 22pF	4/50p
SMALL MULLARD 5 to 50pF	4/50p
larger type grey 2 to 25pF black 15 to 90pF	
TRANSISTORS 2N4427	60p
FEED THRU CERAMIC CAPS 1000pF	10/£1
MICROWAVE X BAND GUNN OSCILLATOR 9 TO 11GHz EX-EQUIPMENT (DOPPLER SHIFT MICROWAVE MODULE)	£9.50

MINIATURE RELAYS Suitable for RF

5 volt coil 1 pole changeover	£1
5 volt coil 2 pole changeover	£1
12 volt coil 1 pole changeover	£1

MONOLITHIC CERAMIC CAPICITORS

10n 50v 2.5mm	100/£4.50
100n 50v 2.5mm or 5mm	100/£6
100n ax short leads	100/£3
100n ax long leads	100/£6
100n 50v dil package 0.3" rad	£10/100

STEPPER MOTORS

7.5 DEGREES PER STEP 2 12 volt windings	£4
---	----

KEYTRONICS

TEL. 0279-505543

FAX. 0279-757656

P O BOX 634

BISHOPS STORTFORD

HERTFORDSHIRE CM23 2RX

MAIL ORDER ONLY

MIN CASH ORDER £3.00 OFFICIAL ORDERS WELCOME
UNIVERSITIES COLLEGES SCHOOLS GOVT. DEPARTMENTS

MIN. ACCOUNT ORDER £10.00

P&P AS SHOWN IN BRACKETS (HEAVY) ITEMS

65p OTHERWISE (LIGHT) ITEMS

ADD 15% VAT TO TOTAL

ELECTRONIC COMPONENTS

BOUGHT FOR CASH



The aim of this project is to enable readers to use a television set as an oscilloscope. It has several applications. Primarily, it will have enormous appeal for anyone who is interested in electronics but does not wish to spend a few hundred quid on a true scope. This will cost you less than £100. For those who already have a scope, this interface will provide an additional visual means of monitoring signals and can be used in parallel to the scope. It has a third application as well: as an educational project allowing teachers to display signal waveforms on a large screen for the benefit of the whole class. Fourthly, it will give experience in high speed digital electronics and an insight into the nature of tv and computer screen control.

As a circuit design, the project is worth studying in its own right, even if you don't intend building it, for it is a good example of an interactive digital system in which the operation of each part is heavily dependent upon feedback from other parts in a semi-closed network.



PE TELE-SCOPE

WHAT IT DOES

The project is an interface which samples signal waveforms and converts them into a format which can be sent to a tv via its aerial socket. It is not necessary to make any internal modification to the tv. The tv will simply react to the interface signals as if they had originated from a tv transmitter, video recorder or computer video output. The only requirement for the tv is that it should be capable of being tuned to channel 36. This channel is the same one as required for use with many home computers, such as the BBC and Commodore 64, etc. The interface can be used with colour or black and white tvs.

Digital and analogue signals can both be handled by the interface and displayed on the tv screen. The input frequency range is from dc to in excess of 2MHz.

Many of the facilities found on true oscilloscopes are included: manual and automatic synchronisation control; ac and dc signal selection; input amplitude and gain control; triggering on either positive or negative edges of the waveform; frequency range selection; internal or external sync selection; internal or external time-base clock selection. An additional control allows the signal to be 'frozen' at any moment and displayed as a static waveform on the screen, remaining unchanged for as long as you want. In other words, it acts as a storage scope.

LIMITATIONS

Those are the 'pros'. There are, though, some 'cons'. The main drawback is that the

After years of waiting for the technology to become available, John Becker presents a PE first – an interface that turns your tv into an oscilloscope!

displayed waveform is a sampled one. This means that with analogue signals (sine waves, triangle waves etc.) the displayed trace will consist of discrete steps and not be as smooth as with an ordinary scope.

For square waves I have used a different sampling technique to that used for analogue signals and the resulting display does not consist of discrete steps. The adverse effects of sampling square waves does not become significantly apparent until the input frequency approaches that of the sampling clock. When the sampling clock is not synchronised to the input frequency, the duration of each input square wave as seen on the screen will vary fractionally. The variation will be related to the phase of the signal and the clock at the moment the sample is taken.

The sampling technique also places

limitations on the use of the unit to measure relative dc signal levels. These will only be displayed to within an accuracy of \pm one vertical screen step. However, there are 64 vertical steps available, so the drawback is only a minor one.

Despite the limitations, the 'Tele-Scope' is a very useful adjunct to the hobbyist's test bench. As a visual signal monitor and tracer it will open new horizons for those who feel blind-folded when only using a meter to check circuit operations.

REVIEWING TECHNOLOGY

So far as I know, no hobbyist magazine has ever published a project that enables a tv to be used as a high-speed scope. (If anyone knows differently, please let me know!) My own idea for designing one goes back many years to when much of my hobby time was spent messing around with old tvs. One year I had persuaded my home-built scope to display miniature green tv pictures. Could I reverse the situation, I wondered, using the tv as a scope? By hard-wiring into parts of the tv, I found that I could but, without completely modifying the tv's time-base generators (which was beyond my abilities at that time), the result had a very limited bandwidth. The limit, of course, was dependent on the tv's horizontal scan rate, which had been set by the manufacturers to be pretty tightly fixed.

Some years later I experimented with feeding a modulated signal into the tv aerial input to see if I could come up with a project suitable for PE readers to use without modifying tv circuitry. I achieved results, but could not give the unit the input frequency range I wanted. It also had the



slight drawback of displaying the signal sideways! To achieve a vertical display without turning a tv on its side it is necessary to sample the vertical-going input signal and replay it horizontally. At that time, semiconductor technology was insufficiently advanced to allow sampled reorientation to be readily carried out at any meaningful speed. To have produced such a sophisticated unit in those days (20 years ago?) would have involved many, many components and pcbs.

I was reminded of my ancient experiments when the screen of my workshop computer (Commodore 3032) failed. Until I was able to obtain a circuit diagram for the display circuitry (ultimately offered and supplied by many kind PE readers) I had to use a portable tv as the monitor. This first required me build a uhf modulator and vdu signal mixer to interface between the computer and tv. Building the module prompted me to re-examine the feasibility of 'tele-scopes'. The technology required is well and truly with us now. Hence the PE Tele-Scope. Its functional block diagram is shown in Fig.1.

SIMPLE COMPLEXITY

The block diagram may look complex to some of you, and indeed there are a lot of parameters to be considered when designing a project such as this. However, the design complexity should not cause readers to worry unduly about building the project. You don't need to understand all the design logic in order to build and use the unit. Nearly all the chips are digital and there is no tricky setting-up to be carried out. Providing the components are bought from a reliable source and care is taken

when soldering the pcb and wiring, assembly of the unit should be within most reader's capabilities.

The design has five main circuit sections: input signal conditioning, signal sampling, storage, synchronisation timing, and tv interface.

UP, DOWN AND SIDWAYS

Conventionally, we regard a signal waveform as having an amplitude which varies vertically. If this amplitude is displayed on a screen then a high voltage will be displayed at a higher point of the screen than a lower voltage. We also regard time as travelling horizontally. In keeping with these basic man-made assumptions, an oscilloscope moves a glowing dot across its screen from left to right, representing the time factor. The dot can also be moved up or down the screen depending on the voltage level detected by the scope's circuitry at a given point in time. When the dot reaches the right hand side of the screen it shoots back to the left and restarts its travel across. With suitable synchronisation, the relationship between the horizontal timing and vertical deflection can be controlled so that a waveform becomes displayed on the screen.

With a scope, the vertical position of the screen dot is always relative to the signal level being monitored, and the rate at which it travels across the screen can be readily changed by varying the rate of a separate controlling oscillator. With a tv set, both the vertical and horizontal dot deflections are related to time (though of course it's voltage which causes the dot to be in a particular position). The tv set has two internal oscillators, one controlling the vertical position, the other controlling the

horizontal. Vertically, the dot travels down the screen and back again to the top 50 times a second (60 times in some countries, and also see the notes at the end of part two). For each time the dot travels down the screen, it is also caused to travel across it a far greater number of times. With the tv sets in common use now the horizontal rate is 625 times for each vertical transition (though in earlier times the horizontal rate used to be 405 times). Neither of the rates can be significantly varied by the tv's user-accessible controls. Nor can we apply an external voltage to the dot in order to change its screen height. How, then, can we cause the tv to shows its dot in a position relative to an external signal voltage and timing factor? By a bit of jiggery-pokery!

BLANKING

A tv signal appears as a picture on the screen due to third option available with a tv tube (cathode ray tube, or crt), that of being able to vary the brilliance of the dot, from nil to full. These changes in brilliance are controlled by the signal transmitted to the tv by the broadcasters and are synchronised to the correct vertical and horizontal positions. We can also use this tube attribute in order to create the illusion of a scope-type waveform display, by turning the dot on and off at related points during its vertical and horizontal travels.

SAMPLING

Two processes are required. First, we take samples of the signal voltage at frequent intervals, storing the result each time as an

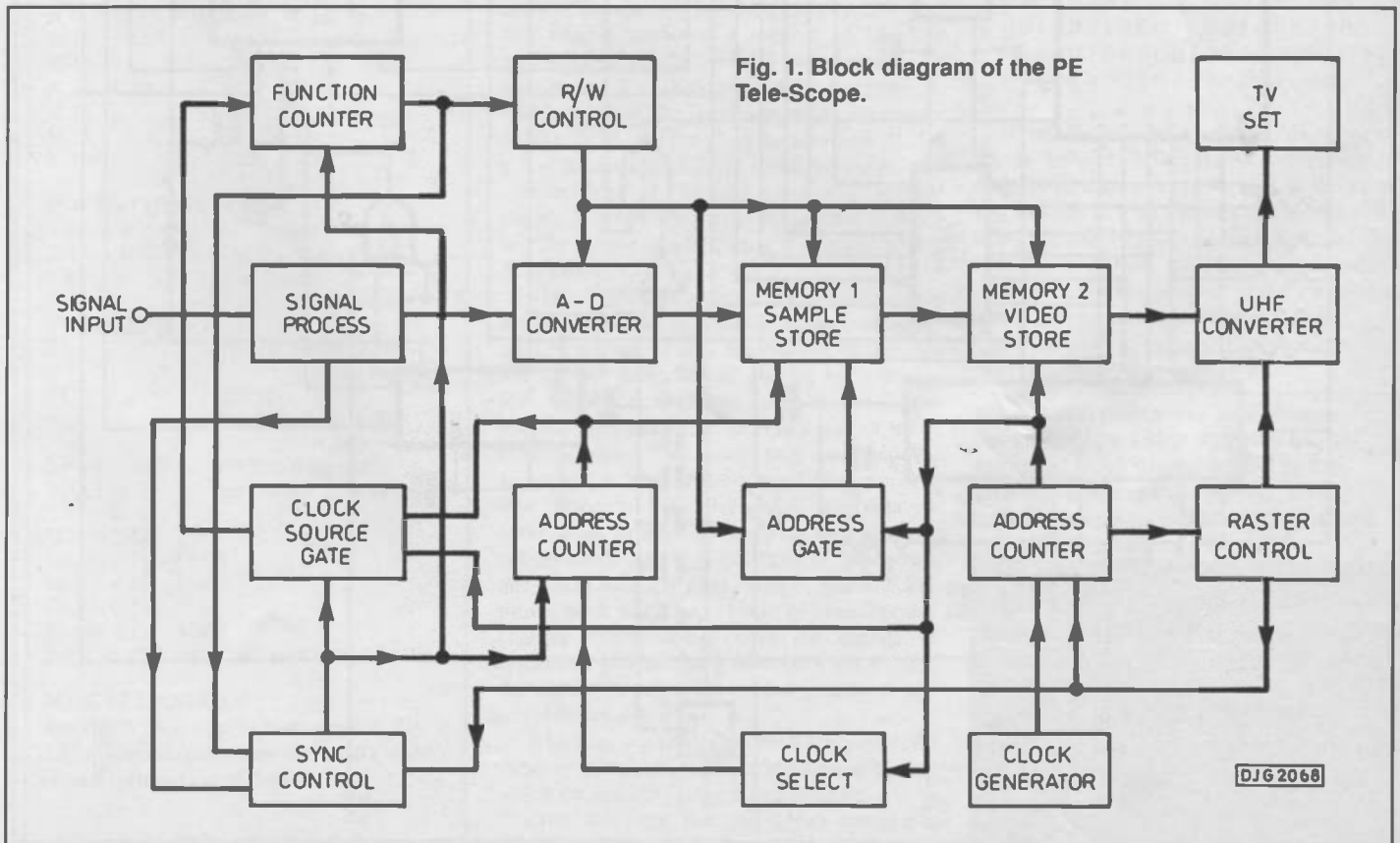
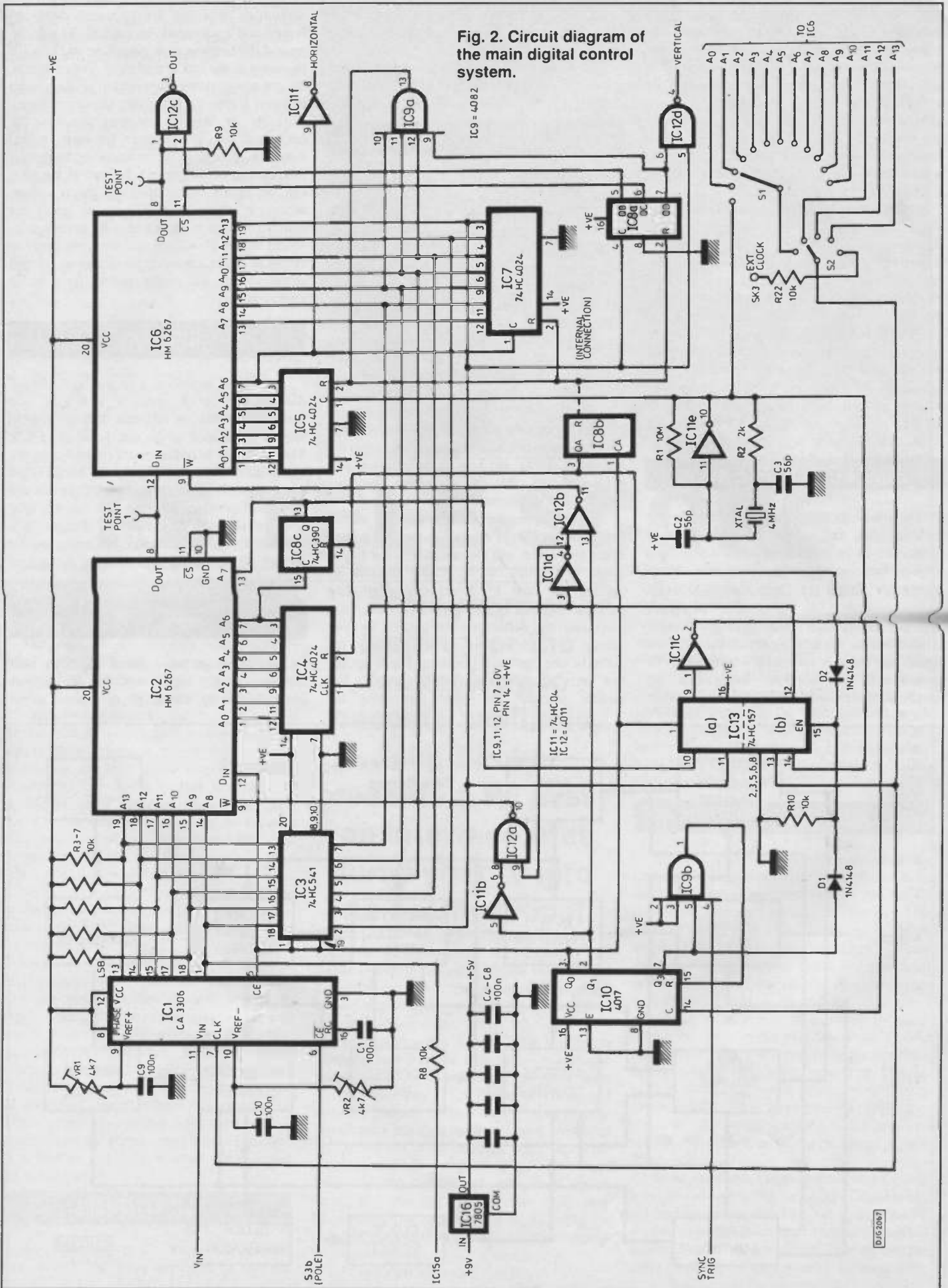

Fig. 1. Block diagram of the PE Tele-Scope.

Fig. 2. Circuit diagram of the main digital control system.





equivalent digital number. The number is related to the equivalent height of the voltage. We can also regard the number as being related to the number of times that a dot has travelled across a tv screen before it has dropped to a particular screen height. The sample number can therefore be regarded as representing the screen line number.

For example, suppose that we are able to sample the signal at 625 different points during its vertical travel. We could then regard point 1 as representing the highest possible voltage, and

point 625 as representing the lowest possible voltage. If an individual sample shows that a voltage is present when point 13 is sampled, then that sample can be considered as occurring on tv line 13, likewise point 14 would relate to line 14, point 97 to line 97, and so on. Having taken a group of samples of the signal and stored it, we then replay the store telling the tv to turn on its dot only if the line count corresponds to the same number held in store. If the same number is not in store, then the screen remains blank for that line. In the example above, only lines 13, 14 and 97 would have the dot displayed on them.

Of course, we also have to tell the tv at what point along each line the dot should be turned on or off. We don't necessarily want the screen to show the dot moving across its full width, that would just look like streaks on the screen. It is also necessary, then, to relate the taking of each sample not only to the voltage, but also to the time at which it is taken. The process needs to be synchronised.

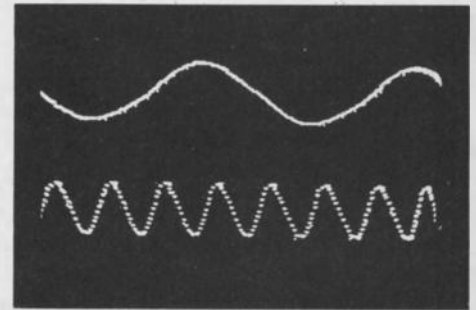

Photographs taken of the author's tv screen using the Tele-Scope to display two analogue waveforms at different frequencies. It can be seen that the definition is dependent on the sampling rate.

second memory. This will be discussed later; it is used to enable the screen to constantly display the previous samples while the first memory is busily recording another batch.)

COMPONENTS

MAIN UNIT AND SIGNAL BOARD

RESISTORS

- R1 10M
- R2 2k
- R3-R10, R15, R19, R20, R22 10k (12 off)
- R11, R16-R18 100k (4 off)
- R12 1M
- R13, R14, R21 4k7 (3 off)
- All 0.25W 5% carbon film

CAPACITORS

- C1, C4-C10 100n polyester (8 off)
- C2, C3 56p polystyrene (2 off)
- C11 220n polyester
- C12 1n8 polystyrene
- C13-C15 33µ 6.3V elect (3 off)
- C16 100p polystyrene

SEMICONDUCTORS

- D1, D2 1N4148 (2 off)
- IC1 CA3306
- IC2, IC6 HM6267 (2 off)
- IC3 74HC541
- IC4, IC5, IC7 74HC4024 (3 off)
- IC8 74HC390
- IC9 4082
- IC10 4017
- IC11 74HC04
- IC12, IC15 4011 (2 off)
- IC13 74HC157
- IC14 TL084
- IC16 7805

POTENTIOMETERS

- VR1, VR2 4k7 preset
- VR3, VR5, VR6 1M lin rotary (3 off)
- VR4 10k preset

SWITCHES

- S1 1p12w break-before-make rotary
- S2 2p6w break-before-make rotary
- S3 dpdt min toggle
- S4-S7 spst min toggle (4 off)

SOCKETS

- 14-pin dil ic (8 off)
- 16-pin dil ic (3 off)
- 18-pin dil ic
- 20-pin dil ic (3 off)
- 2mm sockets for inputs (see text) (3 off)

MISCELLANEOUS

- Knobs (5 off), box to suit (approx 210 x 150 x 40mm), pcb supports (8 off), 4MHz crystal, printed circuit boards.

CELL BLOCKS

To achieve sync we don't actually store the sampled number as such. Instead, we regard the number as being the address in memory at which a 1 or 0 is stored. Before each group of samples is taken, the memory contents are all set to zero. We then regard the memory as consisting of several blocks of addresses. Each block is treated as the storage area relating to an individual screen line. A separate automatically controlled clock counter is also used which sets another set of addresses which relate to individual memory cells within each block.

In the example above, suppose the clock counter has reached a count number of 20. The first sample produced a number of 13. The memory thus selects block 13 and places a 1 at its 20th cell. The clock steps on by one place, at which moment the next sample is taken. Its number is 14, and the clock number now 21. So a 1 is stored at cell 21 of block 14. Again the counter steps on by one place and another sample is taken. This time the counter is at 22 and the sample is at 97. So a 1 is stored at cell 22 of block 97.

The sampling takes place for as many times as there are cells in a block. If the number of cells in a block is 256, the number of samples that will be taken before playing back is also 256. At the end of the sampling batch, the memory then has all its address lines put under counter control. The counter now waits until the screen dot is back at the start of line one. It is then triggered to play back its data in consecutive order, first stepping through each cell of block one, then each cell of block two, and so on until the final count is reached. The timing is set so that the change of block number changes synchronously with the change of screen line number. Each time a cell has a 1 in it the screen dot is turned on, but turned off if a cell contains a 0.

When the full replay has been completed, the memory is then reset with 0s in all its cells, after which the sampling process begins again.

(You will spot that the circuit contains a

ILLUSTRATION

To illustrate the sampling point, let's take a couple of examples, just looking at a section of memory having five blocks each of 21 cells. Suppose that during sampling the following sample numbers are produced consecutively during cell count numbers 1 to 21.

- 1, 2, 3, 4, 5, 4, 3, 2, 1, 2, 3, 4, 5, 4, 3, 2, 1, 2, 3, 4, 5

At each sample a 1 is stored in the relevant cell. This can be visualised in tabular form, with the cell count horizontally, and the sample/block number vertically:

```

100000001000000010000
010000010100000101000
001000100010001000100
000101000001010000010
000010000000100000001
    
```

If you squint your eyes you should see that the 1s follow a triangular waveform pattern. And if that data were to be sent to the tv as a series of bits turning the screen on or off, 105 of them, consecutively along each line and down each block in turn, the screen would actually show a triangular waveform at the top left hand corner, five lines deep and 21 bits long.

On another occasion, the memory might record this next sequence:

Also taken using the Tele-Scope, these photos show a digital signal sampled both digitally and in the analogue sampling modes. The sample steps in the analogue mode are clearly shown.

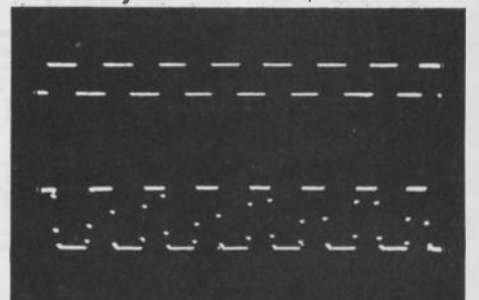

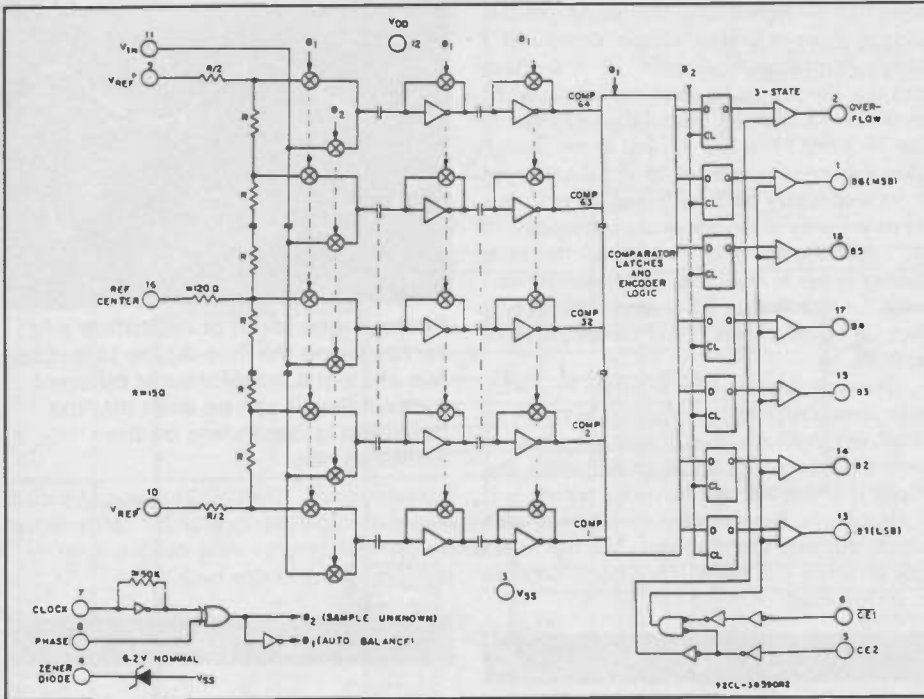
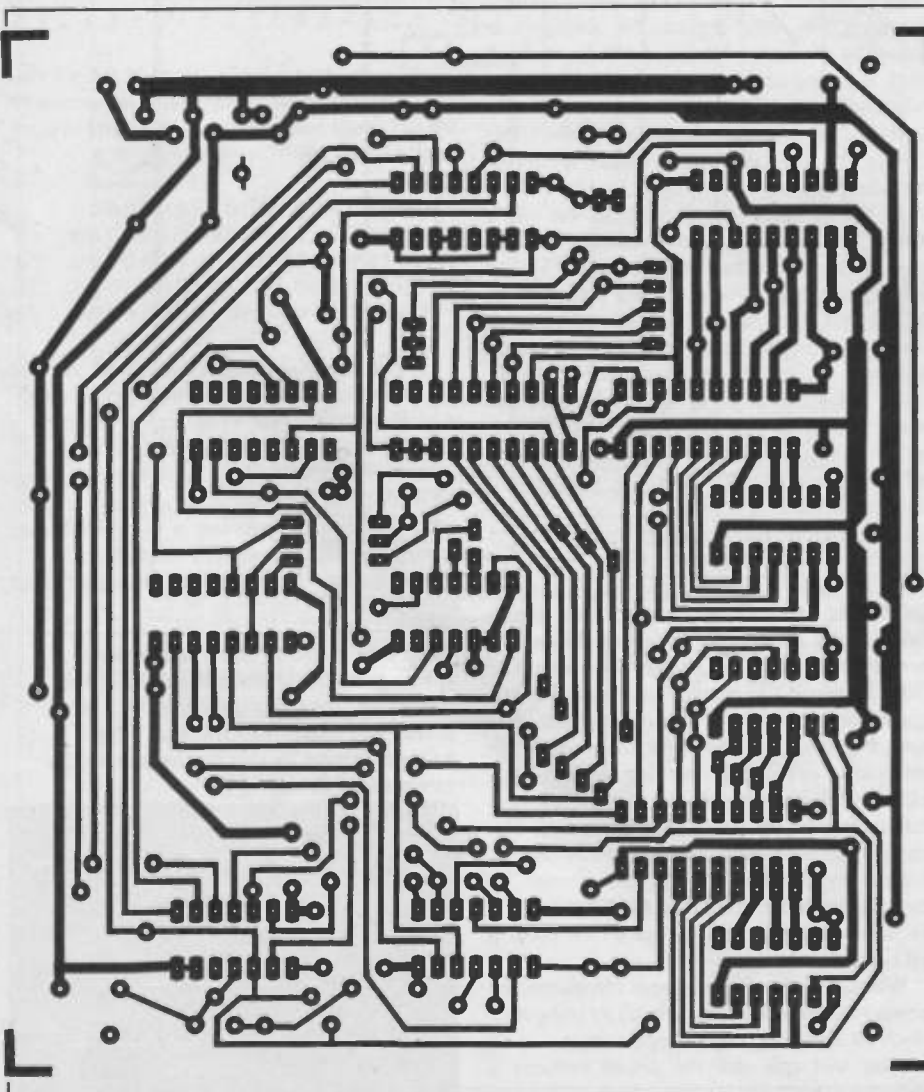

Fig. 3. Block diagram of the CA3306. Kindly supplied by Harris Semiconductors.

Fig. 4. Main printed circuit board track layout for the digital system of the Tele-Scope.



1, 1, 1, 1, 1, 5, 5, 5, 5, 5, 1, 1, 1, 1, 1, 5, 5, 5, 5, 1.

In tabular form again, the results would be:

```

111110000011111000001
000000000000000000000
000000000000000000000
000000000000000000000
000001111100000111110

```

... which is getting on towards being a square wave. A true square wave would of course be expected to show an instantaneous change between high and low. But any transition, however fast, always take time to complete, and there will always be a slope between opposing aspects of a square wave (though it will be too fast to see except on the most sophisticated equipment). This will be especially true of digitally sampled waveforms where only one sample can be taken at any given moment. The next sample will always be placed in the next memory cell.

This is the reason why I have used two different sampling techniques in the unit, one for digital and the other for analogue signals, as you will see shortly.

SCREEN MEMORY OPTIONS

The tabular examples above are a very coarse representation of waveforms and we can achieve far better results if we use a very fast sampling rate, squeezing as many dots as we possibly can onto each screen line. There are practical matters to consider, though, such as the maximum rate at which circuitry can handle all the necessary procedures, and the availability of memory space. Suppose we want 1000 dots on each line and we want to use all 625 lines. We would need a memory of 625000 bits. Not an unreasonable demand it would seem. But those 625000 memory cells have to be accessed once every 50th of a second, requiring an address clock rate of 31.25MHz. Memories of that size and speed are beyond the pockets of those for whom this project is intended. And if money is no object, you'd be better advised to spend it on a true scope. The main intention of this project is to offer visual test bed facilities at a lower cost.

Let's look at the situation from that side, then. What high speed 1-bit memories are available at a reasonable price? A 16K x 1-bit memory such as the 6267 is an obvious choice. It costs about £8.00 at full retail price but by shopping around can probably be bought for less.

We have to partition the chip into blocks and lines, and with a 16K memory (having 16384 locations) we have to compromise between dot definition and screen area usage. I have opted for a split for 64 lines with 256 bits available for each line. Accessing 64K 50 times a second requires a minimum clock speed of around 820kHz, though of course we actually need a faster clock than this since we are now only using part of the screen, and we must also synchronise with the screen line generator built into the tv.



SAMPLING CONSIDERATIONS

The speed, cost and availability of the signal sampling chip is the next consideration. Many of you will be familiar with well-established analogue to digital converters such as the ZN427 and ZN448. These, though, have a maximum conversion rate of 10 microseconds, meaning that only 100,000 samples can be taken each second. For analogue signals, sampling must be carried out at least three times faster than the signal's frequency, consequently a sampling rate of 100kHz allows a maximum input frequency of about only 33kHz. The ZN427 and ZN448 are thus far too slow for a unit which I wanted to be able to handle signals of at least 1MHz.

A chip which allows that rate and which is available at a reasonable cost (about £7) is the CA3306 flash adc, (see Fig. 3). This is a 6-bit converter which can handle in excess of 10 million a-d conversions per second. Its 6-bit output produces 64 separate address numbers, which suits the memory split discussed above. Being a slightly specialist chip, the CA3306 may not be widely available from hobbyist suppliers. If you have any difficulties purchasing it, or the memory chip 6267, contact the manufacturers' UK distributors, such as

Electromail (a company related to RS Components) on 0536 204555. But give your regular supplier a call first since he may stock them and not have told me about it. He may also offer to get them for you - tell him they're useful chips to have on sale.

SAMPLING CIRCUIT

The d-a chip CA3306 is shown as IC1 in the main circuit diagram, Fig.2. The input signal to be converted is brought into the chip's pin 11. Inside the chip is a ladder network of resistors which preset separate comparison voltages against which the input signal is judged. The judging is performed by a series of comparators whose outputs are fed to coded latch gates. The gates need to be triggered by an external clock pulse allowing them to pass their data to the outputs.

The clock signals can come in to the chip via its pin 7 at any (preferably consistent) rate up to at least 10MHz. The unit has been designed to allow the clock to come from an external signal generator, or directly from within the unit. Internally, the clock source is derived from the 4MHz master oscillator circuit around IC11e which controls the address counters. The signal can be applied at the full 4MHz rate, or as a

binary subdivision of it via the counters IC5 and IC7. Between them, switches S1 and S2 select the clocking rate.

The voltage range across which IC1 will produce its full selection of output numbers, 0 to 63, is determined by two reference voltages, one each for the upper and lower limits. The inclusion of VR1 and VR2 at IC1 allows these levels to be preset. There is nothing tricky about setting the best levels as the effects of adjusting the presets will be clearly seen on the tv screen.

IC1 has tri-state outputs, meaning that in addition to being able to deliver the converted code as high and low logic states, a third state exists in which the outputs are turned off. In this mode they have a very high impedance and have no affect upon other circuitry connected to them. Both pins 5 and 6 of IC1 can control the chip's on/off output state. One is used in the analogue conversion process, the other during digital conversion, as described later.

RECORDING

In the analogue conversion mode, the outputs are held open by a high voltage applied to IC1 pin 5 by IC10 pin 3. The output numbers act as one address code sent to the first memory chip, IC2. These numbers represent the block address codes referred to earlier. The second set of address codes is delivered sequentially to IC2 from the counter IC4, whose clock source depends on whether the memory is recording or playing back.

During recording, IC4 is clocked at the same rate as IC1, although the signal is routed via the multiplexed gate IC13 (in to pin 13, and out of pin 12). The same clock signal also controls IC2's read-write mode, though it is routed by an inverter, IC11d, and another gate, IC12a.

On receipt of the clock's positive-going pulse, IC1 is triggered, passing its conversion code to IC2 lines A8 to A13. Simultaneously, the read/write pin of IC2 goes high, putting the memory into playback mode. Counter IC4 is unaffected by the positive clock level. When the clock goes low, IC1's outputs retain their conversion code, IC4 is stepped on by one place, and IC2 is put into write (record) mode. (In other applications IC1 could be triggered by the negative-going pulse edge by taking the Phase pin 8 to 0V instead of +5V.)

At this moment, the address seen by IC2 represents the block number from IC1 and the line number from IC4. Into that address is written a logic 1, as supplied by the currently-high pin 3 of IC10 (a decade counter). When the clock goes high again, the process will be repeated and logic 1 placed into the next consecutive line address at the new block address from IC1.

The process continues until IC4 has cycled twice through its count, finally triggering IC8c so that its Q output, pin 13, goes low. IC8c can simply be regarded as an extension of IC4, allowing for an 8-bit count rather than a 7-bit one. The low-going output of IC8c is taken into pin 10 of the multiplexer IC13, out through its pin 9, via the inverter IC11c, and then to the decade counter IC10, clocking it on by one place.

We shall learn next month what happens now!

Fig. 5. Component layout on the main digital system printed circuit board.

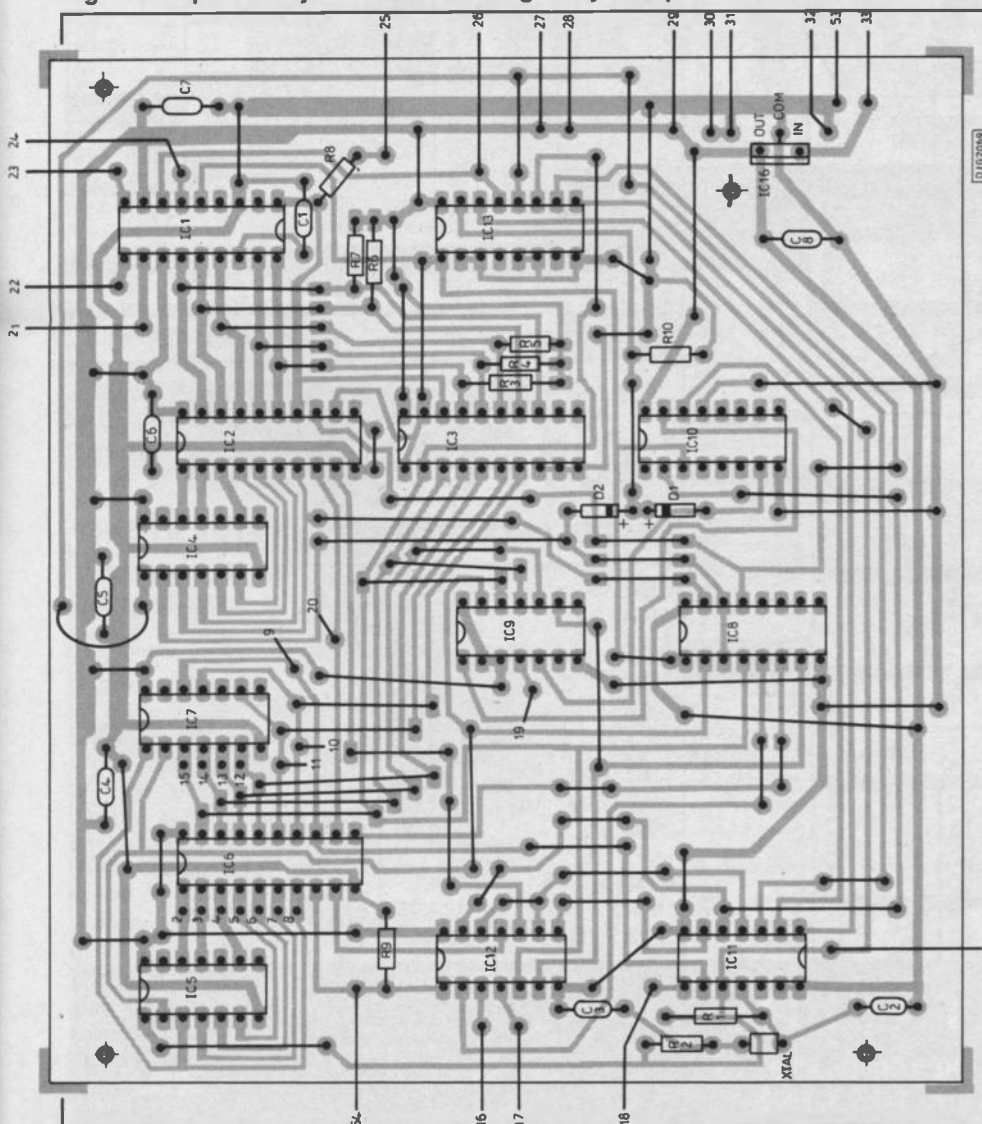

TTLs		74LS SERIES		74ALS SERIES		74S SERIES		74V SERIES		74VCT SERIES		74VHC SERIES		74VHC16 SERIES		74VHC162 SERIES		74VHC163 SERIES		74VHC164 SERIES		74VHC165 SERIES		74VHC166 SERIES		74VHC167 SERIES		74VHC168 SERIES		74VHC169 SERIES		74VHC170 SERIES		74VHC171 SERIES		74VHC172 SERIES		74VHC173 SERIES		74VHC174 SERIES		74VHC175 SERIES		74VHC176 SERIES		74VHC177 SERIES		74VHC178 SERIES		74VHC179 SERIES		74VHC180 SERIES		74VHC181 SERIES		74VHC182 SERIES		74VHC183 SERIES		74VHC184 SERIES		74VHC185 SERIES		74VHC186 SERIES		74VHC187 SERIES		74VHC188 SERIES		74VHC189 SERIES		74VHC190 SERIES		74VHC191 SERIES		74VHC192 SERIES		74VHC193 SERIES		74VHC194 SERIES		74VHC195 SERIES		74VHC196 SERIES		74VHC197 SERIES		74VHC198 SERIES		74VHC199 SERIES		74VHC200 SERIES		74VHC201 SERIES		74VHC202 SERIES		74VHC203 SERIES		74VHC204 SERIES		74VHC205 SERIES		74VHC206 SERIES		74VHC207 SERIES		74VHC208 SERIES		74VHC209 SERIES		74VHC210 SERIES		74VHC211 SERIES		74VHC212 SERIES		74VHC213 SERIES		74VHC214 SERIES		74VHC215 SERIES		74VHC216 SERIES		74VHC217 SERIES		74VHC218 SERIES		74VHC219 SERIES		74VHC220 SERIES		74VHC221 SERIES		74VHC222 SERIES		74VHC223 SERIES		74VHC224 SERIES		74VHC225 SERIES		74VHC226 SERIES		74VHC227 SERIES		74VHC228 SERIES		74VHC229 SERIES		74VHC230 SERIES		74VHC231 SERIES		74VHC232 SERIES		74VHC233 SERIES		74VHC234 SERIES		74VHC235 SERIES		74VHC236 SERIES		74VHC237 SERIES		74VHC238 SERIES		74VHC239 SERIES		74VHC240 SERIES		74VHC241 SERIES		74VHC242 SERIES		74VHC243 SERIES		74VHC244 SERIES		74VHC245 SERIES		74VHC246 SERIES		74VHC247 SERIES		74VHC248 SERIES		74VHC249 SERIES		74VHC250 SERIES	
7400	0.30	74LS00	0.24	74ALS00	1.80	4555	0.36	AD7581	12.00	LM748	3.30	TL062	3.25	68809E	12.00	2018-150	4.00	32768Hz	2.00	AD5611	20.00																																																																																																																																																																												
7401	0.30	74LS01	0.24	74ALS01	1.80	4556	0.30	AD7582	11.00	LM1011	4.80	TL061	4.80	68809E	12.00	2101	4.00	1.00 MHz	1.70	AD5611	20.00																																																																																																																																																																												
7402	0.30	74LS02	0.24	74ALS02	1.80	4560	1.40	AD7583	11.00	LM1012	4.80	TL060	4.80	68809E	12.00	2107B	5.00	1.8437 MHz	2.25	AD5611	20.00																																																																																																																																																																												
7403	0.30	74LS04	0.24	74ALS04	1.80	4566	1.40	AD7584	11.00	LM1013	3.00	TL060	3.00	68809E	12.00	2111A 35	4.00	2.4570 MHz (S)	2.50	AD5611	20.00																																																																																																																																																																												
7404	0.36	74LS05	0.24	74ALS05	1.80	4568	2.40	AD7585	11.00	LM1014	3.00	TL060	3.00	68809E	12.00	2114	1.50	3.12 MHz	1.75	AD5611	20.00																																																																																																																																																																												
7405	0.30	74LS08	0.24	74ALS08	1.80	4569	1.70	AD7586	11.00	LM1015	3.00	TL060	3.00	68809E	12.00	2117	4.00	3.12 MHz	2.50	AD5611	20.00																																																																																																																																																																												
7406	0.40	74LS09	0.24	74ALS09	1.80	4572	0.45	AD7587	11.00	LM1016	3.00	TL060	3.00	68809E	12.00	2118	1.50	3.12 MHz	1.75	AD5611	20.00																																																																																																																																																																												
7407	0.40	74LS10	0.24	74ALS10	1.80	4583	0.90	AD7588	11.00	LM1017	3.00	TL060	3.00	68809E	12.00	2119	1.50	3.12 MHz	1.75	AD5611	20.00																																																																																																																																																																												
7408	0.30	74LS11	0.24	74ALS11	1.80	4584	0.48	AD7589	11.00	LM1018	3.00	TL060	3.00	68809E	12.00	2120	1.50	3.12 MHz	1.75	AD5611	20.00																																																																																																																																																																												
7409	0.30	74LS12	0.24	74ALS12	1.80	4585	0.48	AD7590	11.00	LM1019	3.00	TL060	3.00	68809E	12.00	2121	1.50	3.12 MHz	1.75	AD5611	20.00																																																																																																																																																																												
7410	0.30	74LS13	0.36	74ALS13	1.20	4724	1.50	AD7591	11.00	LM1020	3.00	TL060	3.00	68809E	12.00	2122	1.50	3.12 MHz	1.75	AD5611	20.00																																																																																																																																																																												
7411	0.30	74LS14	0.50	74ALS14	2.25	4441	1.50	AD7592	11.00	LM1021	3.00	TL060	3.00	68809E	12.00	2123	1.50	3.12 MHz	1.75	AD5611	20.00																																																																																																																																																																												
7412	0.30	74LS15	0.24	74ALS15	1.80	4442	1.50	AD7593	11.00	LM1022	3.00	TL060	3.00	68809E	12.00	2124	1.50	3.12 MHz	1.75	AD5611	20.00																																																																																																																																																																												
7413	0.30	74LS16	0.24	74ALS16	1.80	4443	1.50	AD7594	11.00	LM1023	3.00	TL060	3.00	68809E	12.00	2125	1.50	3.12 MHz	1.75	AD5611	20.00																																																																																																																																																																												
7414	0.70	74LS21	0.24	74ALS21	3.00	14419	2.80	AD7595	11.00	LM1024	3.00	TL060	3.00	68809E	12.00	2126	1.50	3.12 MHz	1.75	AD5611	20.00																																																																																																																																																																												
7416	0.36	74LS22	0.24	74ALS22	3.00	14490	4.20	AD7596	11.00	LM1025	3.00	TL060	3.00	68809E	12.00	2127	1.50	3.12 MHz	1.75	AD5611	20.00																																																																																																																																																																												
7417	0.40	74LS24	0.50	74ALS24	2.25	14495	4.20	AD7597	11.00	LM1026	3.00	TL060	3.00	68809E	12.00	2128	1.50	3.12 MHz	1.75	AD5611	20.00																																																																																																																																																																												
7420	0.40	74LS25	0.24	74ALS25	3.00	14500	6.30	AD7598	11.00	LM1027	3.00	TL060	3.00	68809E	12.00	2129	1.50	3.12 MHz	1.75	AD5611	20.00																																																																																																																																																																												
7421	0.60	74LS27	0.24	74ALS27	3.00	14599	3.00	AD7599	11.00	LM1028	3.00	TL060	3.00	68809E	12.00	2130	1.50	3.12 MHz	1.75	AD5611	20.00																																																																																																																																																																												
7422	0.36	74LS28	0.24	74ALS28	3.00	22100	3.00	AD7600	11.00	LM1029	3.00	TL060	3.00	68809E	12.00	2131	1.50	3.12 MHz	1.75	AD5611	20.00																																																																																																																																																																												
7423	0.36	74LS30	0.24	74ALS30	4.00	22101	7.00	AD7601	11.00	LM1030	3.00	TL060	3.00	68809E	12.00	2132	1.50	3.12 MHz	1.75	AD5611	20.00																																																																																																																																																																												
7425	0.40	74LS32	0.24	74ALS32	3.00	40966	0.80	AD7602	11.00	LM1031	3.00	TL060	3.00	68809E	12.00	2133	1.50	3.12 MHz	1.75	AD5611	20.00																																																																																																																																																																												
7426	0.40	74LS33	0.24	74ALS33	3.00	40014	0.48	AD7603	11.00	LM1032	3.00	TL060	3.00	68809E	12.00	2134	1.50	3.12 MHz	1.75	AD5611	20.00																																																																																																																																																																												
7427	0.32	74LS37	0.24	74ALS37	1.70	40085	1.20	AD7604	11.00	LM1033	3.00	TL060	3.00	68809E	12.00	2135	1.50	3.12 MHz	1.75	AD5611	20.00																																																																																																																																																																												
7428	0.43	74LS38	0.24	74ALS38	2.50	40097	0.36	AD7605	11.00	LM1034	3.00	TL060	3.00	68809E	12.00	2136	1.50	3.12 MHz	1.75	AD5611	20.00																																																																																																																																																																												
7430	0.30	74LS39	0.24	74ALS39	3.00	40966	0.80	AD7606	11.00	LM1035	3.00	TL060	3.00	68809E	12.00	2137	1.50	3.12 MHz	1.75	AD5611	20.00																																																																																																																																																																												
7432	0.36	74LS42	0.50	74ALS42	3.50	40100	1.20	AD7607	11.00	LM1036	3.00	TL060	3.00	68809E	12.00	2138	1.50	3.12 MHz	1.75	AD5611	20.00																																																																																																																																																																												
7433	0.30	74LS47	0.80	74ALS47	3.50	40101	1.20	AD7608	11.00	LM1037	3.00	TL060	3.00	68809E	12.00	2139	1.50	3.12 MHz	1.75	AD5611	20.00																																																																																																																																																																												
7437	0.30	74LS48	0.90	74ALS48	3.50	40102	1.20	AD7609	11.00	LM1038	3.00	TL060	3.00	68809E	12.00	2140	1.50	3.12 MHz	1.75	AD5611	20.00																																																																																																																																																																												
7438	0.40	74LS51	0.90	74ALS51	3.50	40103	1.20	AD7610	11.00	LM1039	3.00	TL060	3.00	68809E	12.00	2141	1.50	3.12 MHz	1.75	AD5611	20.00																																																																																																																																																																												
7440	0.40	74LS54	0.24	74ALS54	3.00	40104	1.20	AD7611	11.00	LM1040	3.00	TL060	3.00	68809E	12.00	2142	1.50	3.12 MHz	1.75	AD5611	20.00																																																																																																																																																																												
7441	0.80	74LS55	0.24	74ALS55	3.00	40105	1.50	AD7612	11.00	LM1041	3.00	TL060	3.00	68809E	12.00	2143	1.50	3.12 MHz	1.75	AD5611	20.00																																																																																																																																																																												
7442A	0.70	74LS73A	0.30	74ALS73A	1.80	40106	0.48	AD7613	11.00	LM1042	3.00	TL060	3.00	68809E	12.00	2144	1.50	3.12 MHz	1.75	AD5611	20.00																																																																																																																																																																												
7443A	1.80	74LS74A	0.36	74ALS74A	1.80	40107	0.85	AD7614	11.00	LM1043	3.00	TL060	3.00	68809E	12.00	2145	1.50	3.12 MHz	1.75	AD5611	20.00																																																																																																																																																																												
7444	1.10	74LS75	0.45	40001	0.20	40108	3.20	AD7615	11.00	LM1044	3.00	TL060	3.00	68809E	12.00	2146	1.50	3.12 MHz	1.75	AD5611	20.00																																																																																																																																																																												
7445	0.70	74LS76A	0.36	40002	0.20	40109	1.20	AD7616	11.00	LM1045	3.00	TL060	3.00	68809E	12.00	2147	1.50	3.12 MHz	1.75	AD5611	20.00																																																																																																																																																																												
7446A	1.00	74LS78	0.42	40002	0.25	40110	2.25	AD7617	11.00	LM1046	3.00	TL060	3.00	68809E	12.00	2148	1.50	3.12 MHz	1.75	AD5611	20.00																																																																																																																																																																												
7447A	1.80	74LS82A	0.42	40003	0.25	40111	2.25	AD7618	11.00	LM1047	3.00	TL060	3.00	68809E	12.00	2149	1.50	3.12 MHz	1.75	AD5611	20.00																																																																																																																																																																												
7448A	1.00	74LS85	0.42	40003	0.25	40112	2.25	AD7619	11.00	LM1048	3.00	TL060	3.00	68809E	12.00	2150	1.50	3.12 MHz	1.75	AD5611	20.00																																																																																																																																																																												
7450	0.36	74LS86	0.35	40003	0.25	40113	2.25	AD7620	11.00	LM1049	3.00	TL060	3.00	68809E	12.00	2151	1.50	3.12 MHz	1.75	AD5611	20.00																																																																																																																																																																												
7451	0.35	74LS90	0.48	40009	0.45	40114	2.25	AD7621	11.00	LM1050	3.00	TL060	3.00	68809E	12.00	2152	1.50	3.12 MHz	1.75	AD5611	20.00																																																																																																																																																																												
7453	0.38	74LS91	0.80	40010	0.45	40115	2.25	AD7622	11.00	LM1051	3.00	TL060	3.00	68809E	12.00	2153	1.50	3.12 MHz	1.75	AD5611	20.00																																																																																																																																																																												
7454	0.38	74LS92	0.35	40011	0.24	40116	2.25	AD7623	11.00	LM1052	3.00	TL060	3.00	68809E	12.00	2154	1.50	3.12 MHz	1.75	AD5611	20.00																																																																																																																																																																												
7456	0.55	74LS93	0.54	40012	0.24	40117	2.25	AD7624	11.00	LM1053	3.00	TL060	3.00	68809E	12.00	2155	1.50	3.12 MHz	1.75	AD5611	20.00																																																																																																																																																																												
7470	0.50	74LS95B	0.75	40013	0.24	40118	2.25	AD7625	11.00	LM1054	3.00	TL060	3.00	68809E	12.00	2156	1.50	3.12 MHz	1.75	AD5611	20.00																																																																																																																																																																												
7471	0.50	74LS96	0.75	40014	0.24	40119	2.25	AD7626	11.00	LM1055	3.00	TL060	3.00	68809E	12.00	2157	1.50	3.12 MHz	1.75	AD5611	20.00																																																																																																																																																																												
7472	0.45	74LS107	0.40	40015	0.24	40120	2.25	AD7627	11.00	LM1056	3.00	TL060	3.00	68809E	12.00																																																																																																																																																																																		



Radio paging was meant to be a quick and simple method of getting in touch with people on the move, rather like a tap on the shoulder. No long messages to the recipient, just a bleep; this would save on the radio spectrum. Pagers now exist for receiving and storing messages.

Neither are there any facilities for the recipient to communicate with the sender via the pager. The recipient has to get to the telephone to communicate with the sender. This results in a pager that is small and light and requires low power, to power a receiver only.

Therefore pagers are usually small and light, weighing 80 gm to 120 gm. They are also rugged, some of them being designed to withstand up to six drops on a concrete surface from a height of 1.2 metres.

The Electrical Research Association carries out tests on pagers. These are attached to the body in eight different positions to stimulate real life situations. With a 10 μ V/m signal, a call success rate of 80% is achieved with most pagers. Pagers must also be capable of working from within fast moving vehicles and from within buildings. The pagers must be capable not only of detecting signals but also correcting errors.



British Telecom's series 1200 Message Master radio pager.

Mike Sanders turns over to a new pager and gets the message.

station where it is transmitted by radio to the called pager. Four to eight different tones of bleep are available depending on the manufacturer, though in noisy environments it would be difficult to distinguish between the tones.

As pagers have grown in popularity, there

RADIO PAGING

The kind of people who use pagers are the ones who need to be contacted right through the working day but are so mobile that they may not be at a desk or even a car phone for any length of time. Such people are salespersons, service engineers, medical personnel, drivers, people in the construction industry, etc. These people may have to be contacted in order to redirect them elsewhere or for consultations.

ON SITE AND WIDE AREA PAGING

The main coverage areas for paging are on site (within a building or compound) and wide area (in a portion of the country).

On site paging is usually restricted to about a quarter of a mile. Wiring encircles the building and acts as an aerial which is connected to a central transmitter and encoder.

With wide area paging, customers carry equipment which is bought or rented and the pagers are centred on the telephone network.

Wide area networks can cover cities, counties and even the whole country as with British Telecom's Mobile Communications which encompasses more than 400,000 pagers.

In the USA, wide area paging networks started in the 1960s. In the UK, a trial system started in Reading in 1973. The trial was a success and the London network was started in 1976 with just one paging code then two operating at five calls per second. The national service with forty zones was started in 1981 and now uses 380 base stations which

use radio equipment for transmitting the messages.

PAGER TYPES

Pagers used in wide area paging are of three types: tone, display and voice. Specialist pagers also exist. For instance, safe pagers are required in the petrol, chemical and mining industries where there is the risk of an explosion.

Silent pagers are required in noisy environments where a bleep would not be heard and also at a meeting where one would not want to be disturbed. These silent pagers are equipped with a flashing light or a vibrator so that the wearer can feel a message coming in.

But to return to the standard pagers, the tone pager emits a bleep. The caller dials the pager number from a telephone and the call is routed over the telephone network to a base

has been a need for better and more sophisticated display type pagers. Two types exist displaying numeric and alphanumeric information. The numeric type displays telephone numbers only whereas the latter can also display messages.

The advantage of a display pager is that the recipient knows who the message is from and whether an urgent return call is required. This is a far cry from the original two tone pager - one tone usually meant 'call the office' and the other 'call home'. This has meant more air time and therefore a pressure on the radio spectrum.

In order to send a message, the sender calls an office and dictates his message to the operator who then transmits it to the recipient. The more expensive pagers can receive a greater number of alphanumeric characters and store a greater number of messages. When the memory is full, the first message is deleted so the pager works on a first in, first out principle. The owner can protect

Fig. 1. Simple radio paging network.

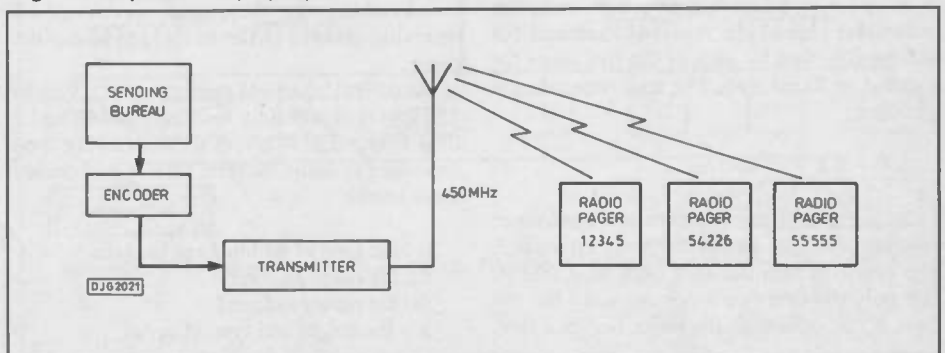

whichever messages he wishes to retain.

Pager memories vary from 10 messages of 40 characters each, to 20 messages of 400 characters each. In addition, pagers exist with a printer option. This is another departure from the original pager which was supposed to be small and light and nudge one in the ribs to say 'call the office'.

With the desire for speedier communications, networks are being set up where there is no need for the caller to get in touch with a central bureau by phone to send a message. Instead messages can be created on a computer which are then downloaded to the bureau computer for automatic transmission.

Bureaux that offer radio paging in addition to British Telecom's Mobile Communications are Inter City, Air Call and Digital Mobile Communications. Some bureaux offer special services like advising which subscribers are out of the country.

In spite of extra air time taken by message paging, one of the useful applications is for a broker to update the price of a commodity to all his contacts. For instance "the price of oil is 10 cents a barrel". (JR would have a fit if he received that one! Ed.)

TECHNICALITIES

A small radio paging network may be thought of comprising an encoder to select the called pager, the base section transmitter and the pagers themselves as in Fig.1. The pager codes may be generated either by a sequence of binary pulses or a combination of audio tones.

One system using audio tones in sequence is known as the ZVEI 5-tone system. Another system adopted by The Consultative Committee for International Radio (CCIR) is shown alongside the ZVEI system for comparison in Fig.2.

The CCIR scheme was meant for marine use but is used by some UK operators for land mobile paging. A modified form of the ZVEI code is also used for the UK 12.5 kHz radio system. As can be seen in Fig.2, the tones last for 70 ms but a modified form of the CCIR used in the UK employs a lower tone duration of 40 ms.

It can be seen from Fig.2 that these are twelve different tones representing digits 0 to 9 and a special function tone X and repeat tone. If five tones (five digits) are used to represent each pager code then 100,000 code combinations can be obtained.

In order to transmit a five digit code the transmitter receives a turn on command for 100 ms followed by each of the five tones for a period of 70 ms each. The total time taken is therefore:

$$100 + 5 \times 70 = 450 \text{ ms}$$

At the end of the sequence the transmitter switches off and awaits the next command. The pager in turn decodes each tone and if, say, only the first two tones are valid but the third is not valid then the pager begins a time

Digit	Tone Frequencies in Hz			
	ZVEI	ZVEI modified	CCIR/EEA	EIA
1	1060	970	1124	741
2	1160	1060	1197	882
3	1270	1160	1275	1023
4	1400	1270	1358	1164
5	1530	1400	1446	1305
6	1670	1530	1540	1446
7	1830	1670	1640	1587
8	2000	1830	1747	1728
9	2200	2000	1860	1869
0	2400	2200	1981	600
Repeat	2600	2400	2110	459
X	970	825	1055	2151
Tone duration (ms)	70	70	100CCIR 40EEA	40

Fig 2. 5-tone systems.

out sequence. If the third code is not received after about 110ms the pager resets and waits for the next transmission.

ZVEI stands for Zentralverband der Elektrotechnischen Industry, the Central Association of the German Electrical Industry. Since it is designed to operate on channel separations of 20kHz there is a problem in transmitting the highest tone of 2800Hz on a 12.5kHz band and the modified ZVEI or depressed ZVEI uses a tone of 825Hz instead of 2800Hz.

Another system developed by the Electrical Industries Association (EIA) is also shown in Fig 2. In general, the systems employing longer timings result in a slower call but increased reliability.

When digits are repeated the repeat tone is used. An example will make this clear. Suppose the number of the called pager is 54226, the pager decoder would respond to only one of the twos and the received code would be 5426. To prevent this, 542R6 is transmitted. Similarly for 55555, 5R5R5 would be transmitted, and so on.

Although 5 tone codes have been discussed, other systems exist using two, three and up to seven tones. The X or alternative tone is used when there is a repeater in the communication link to prevent a burst of interference from keying the repeater link.

The 450MHz (uhf) band is good for radio paging within a city since man-made noise (electrical sparking from motors, etc.) is lower at uhf. Also small wavelengths at uhf are better at penetrating gaps in buildings than vhf. In addition, at these small wavelengths a receiving aerial is easier to include within the pager.

At 450MHz, a field strength of 10µV/m to 15µV/m is required for tone only pagers and a field strength of 40µV/m to 50µV/m for tone and voice systems. Several factors will decide these levels:

- the kind of buildings in the area
- the range required
- the power radiated
- the height and type of aerial.

In order to obtain a satisfactory signal inside a building, the field strength outside the building may have to be as high as 400µV/m to 600µV/m.

The height and gain of an aerial will also determine the area of coverage. Fig.3 shows a low gain aerial on a building and the area of coverage. Fig.4 shows an aerial with a much higher gain than that in Fig.3 and making the aerial directional throws a larger shadow near the building. This means that the signal will be far too weak near the building.

Before a radio paging system is set up, field strength measurements are taken by means of a quarter wave aerial mounted on a car which drives around the area.

BT RADIO PAGING

There are five main paging control centres in London, Birmingham, Manchester, Bristol and Edinburgh which control 40 zones. In order to provide flexible coverage there are also six regions in addition to zones. The regions are larger than zones for those that require large coverage and include the Home

Figs 3 and 4. Low and high gain aerials.

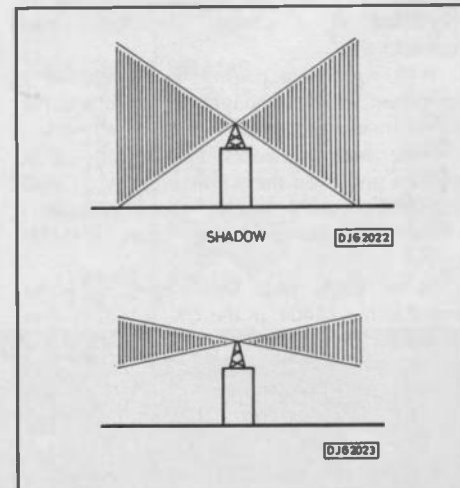

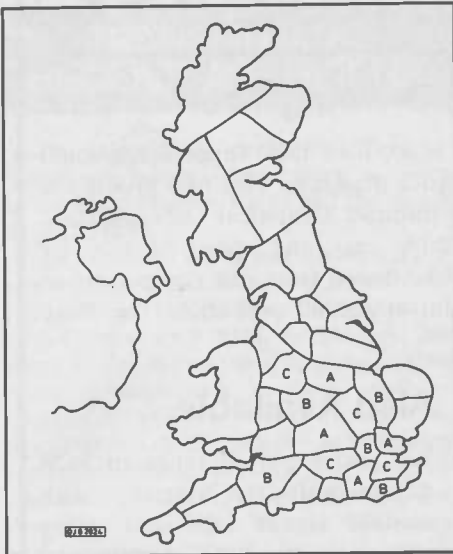

Fig 5. Frequency re-use.

Counties, Midlands, North East, North West, Scotland and West/South Wales.

The British Telecom radio paging network uses transmission frequencies as shown in a honeycomb fashion, as in Fig.5, so that no two frequencies share a common boundary and therefore the likelihood of interference is reduced.

The five main paging control equipment (pce) systems use GEC 4180 mini-computers and are interlinked and each has its message unit for storing and forwarding messages, as in Fig.6. Up to eight zone transmission controllers (ztc) are linked to a pce and up to 24 transmitters to each ztc.

Each pager is parented onto a pce and also allocated a four digit national number followed by six digits which are unique to the pager. Instead of dialling the pager number, a caller can dial the BT radio paging centre directly and get an on-line connection to the pce.

The pce then performs all the translations by looking up tables in its memory regarding the number called, method of routing, call queuing, zones called, etc.

Three 25kHz radio channels are allocated nationally in the 153MHz band. The messages are digitally encoded using the Radio Paging Code number 1 (RPC1) recommended by the CCIR.

The digital signals then modulate a carrier since it is meaningless to transmit a digital train by radio unless it modulates an rf carrier. The type of modulation used is frequency shift keying (fsk) where two frequencies are used, one to indicate mark and the other space. The deviation from the centre frequency is + 4.5kHz and the data rate is 512 bits per second.

Each pager can have up to four unique numbers and the procedure for sending messages is different from bleep only calls. To send a message, the caller telephones a manual bureau and gives the required paging number and message. Alternatively, a message paging number allocated to the home pce can be contacted by telex on dial-up data facilities.

British Telecom radio-paging also offers a voice message storage bank. If this is destined

for a pager with tone only facilities, the message is intercepted and recorded. The recipient is then alerted and can receive the message at any moment after that, by using the telephone.

The transmitters can output 100W and are duplicated at each site but use the same aerial with changeover arrangements. Remote monitoring of each transmitter is achieved from each ztc with each transmitter constantly updating its status.

PAGING CODE 1

In 1975 the Post Office Code Standardisation Advisory Group (POCSAG) was formed to recommend a new paging code because it was realised that the codes in existence at the opening of the London zone would not satisfy the call rate or numbering capacity. The meetings were attended by manufacturers of pagers in Europe, Asia and America.

In 1978 POCSAG published its recommendations for tone only calls. Its capacity was more than two million pagers, each pager having four unique numbers and a call rate of 15 calls per second. The CCIR adopted the recommendations in 1982 and the name was changed from the POCSAG code to the Radio Paging Code Number 1.

Each transmission begins with a preamble consisting of bit reversals and lasting 1.125 seconds. Then follows a string of 32-bit code words encoded in BCH (Bose Chaudhuri Hocquenghem) and made up of:

- 21 information bits
- 10 check digits
- 1 even parity bit.

The code has a Hamming distance of five

and corrects 2-bit errors and detects 3-bit errors.

The earliest tone-only pagers accepted two errors per codeword and corrected one error per message but the capability is improving all the time.

The first numeric message RPC1 pagers were produced in 1983 and the sensitivity was nearly as good as tone only pagers, the loss being about 2dB for a 10 character message.

The inclusion of message paging (numeric and alpha-numeric) reduced the air time slightly. With a traffic load of 70% the delay is 2.5s for a mixture of calls while for tone only calls and a 70% load, the delay is 1s.

The RPC1 code is good and consideration is being given to increasing the transmission rate from 512 bit/s to 1200 bit/s.

CONCLUSIONS

The need for radio paging was felt by a highly mobile society as early as the 1960s and 1970s. Paging coverage can be regarded as on-site or wide area. The on-site being restricted to the building but the wide area being as wide as the network is able to cope.

Types of pagers considered were tone only, numeric, alpha-numeric and voice. The codes in most common use are five tone codes and because there are so many different standards, the networks are incompatible. An advanced code the RPC1 which has received CCIR approval was then discussed.

Modern pagers offer users more than just a bleep, which puts an added strain on air time. Pagers are improving all the time both in memory capacity as well as in the ability to detect and correct errors. All this has been brought about by the large scale integration of circuits.

PE

Fig 6. Radio paging network.

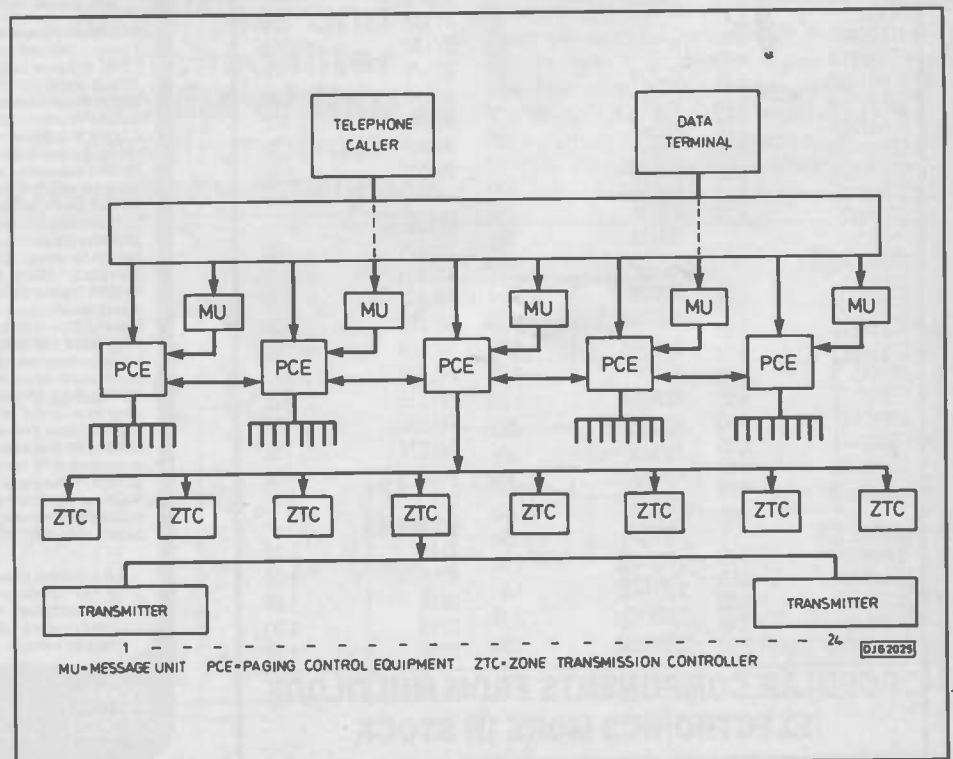

TRANSMIT AND RECEIVE AMPLIFIERS

The transmit and receive amplifiers are housed on a common circuit board as shown in the block diagram Fig.14 and the circuit diagram Fig.15.

The first stage of the transmit section is a combining amplifier using the virtual earth configuration. The amplifier is designed to have a loss of some 20dB. At first sight this seems strange but the signal level through the filters is maintained at about +6dB to minimise the effects of noise in the filters and this level has to be reduced before being applied to the output amplifier. The maximum transmitter output signal level for a single tone is limited to 0dB in order to maintain an adequate overload margin when all ten signals are present, so it is necessary to reduce the filter output level to achieve this. The combining amplifier is followed by a switched attenuator having 10dB steps. This attenuator is interesting in that with accurate components the accuracy of the attenuation steps is better than 0.2dB using standard E24 range component values. The attenuator setting selected by switch S1 is fed to the output amplifier. The output impedance of this amplifier is largely defined by R23 and is

Fig 14. Amplifier board schematic diagram.

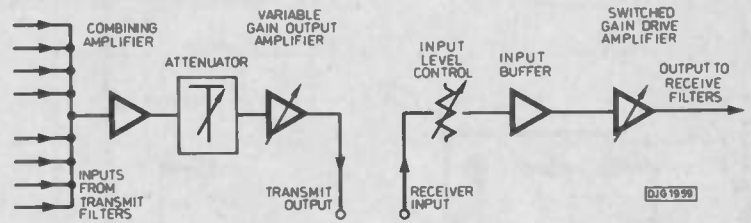

terminated in 600 ohms the size of capacitor required to prevent loss of signal level at 25Hz would be about 47 uF, which could only be realised by using an electrolytic capacitor, and if you use one in which polarity do you connect it? Far safer to use a high quality audio transformer if it is required to isolate the output when feeding a low impedance load.

In the receive section provision is made to terminate the input in 600ohms before the receiver blocking capacitor when switch S3 is closed. Blocking capacitor C1 then prevents any applied dc being fed to the amplifier input. The potentiometer VR24 is provided to allow adjustment of the signal level into the receive amplifier. The second amplifier stage has its gain adjusted by switch S2 to provide controlled steps in receiver sensitivity of 10dB. Standard E24 range components are used.

S3, R24, C1, VR24 and R25 are all mounted on the front panel of the instrument and all other components on the circuit board. The printed circuit track layout is shown in Fig.16 and the component layout in Fig.17.

SWITCHED CAPACITOR FILTERS

Having looked at the conventional method of implementing a band pass filter design it is now time to consider an alternative approach, that of using switched capacitor filters.

One of the problems with using conventional analogue filters is the necessity of making up awkward component values. With switched capacitor filters, provided a suitable circuit configuration is chosen, the

AF OCTAVE MEASURING

600 ohms. The specified output level is obtained when the output is terminated with a 600 ohm resistive load. The level at the amplifier output is thus +dB for a 0dB output signal. The feedback on the output stage is adjusted by potentiometer VR21 to provide a continuous output level adjustment range of 10dB. The maximum output level of 0dB is produced when the potentiometer is set to maximum resistance. It should be noted that the design does not incorporate a blocking capacitor in the transmit output. If the output is used to feed a high impedance load it is practical to provide a blocking capacitor of say 470nF. However, if the output is

Part Two, in which Joe Chamberlain details the amplifiers and switched filter circuits of this multifunction frequency analyser.

response of the filter is defined by resistors (which may be chosen in this application to be standard values) and the frequency of an applied switching signal. The switching signal is 100 times the centre frequency of the filter. This at first sight seems to be an ideal solution to all the filter construction problems but life is never that simple! One of the snags with using any digitally controlled device is that by one mechanism or another spurious products are generated when the frequency of the signal applied to the device approaches that of the switching frequency controlling it.

This phenomenon is known as "aliasing" and occurs due to the production of

Fig 15. Amplifier board circuit diagram.

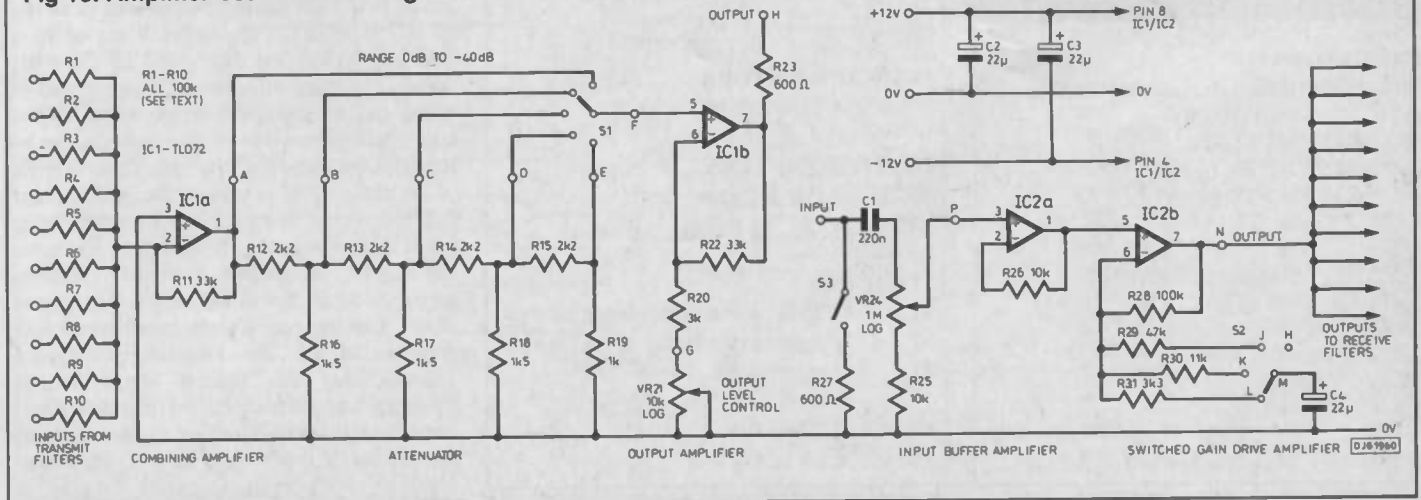

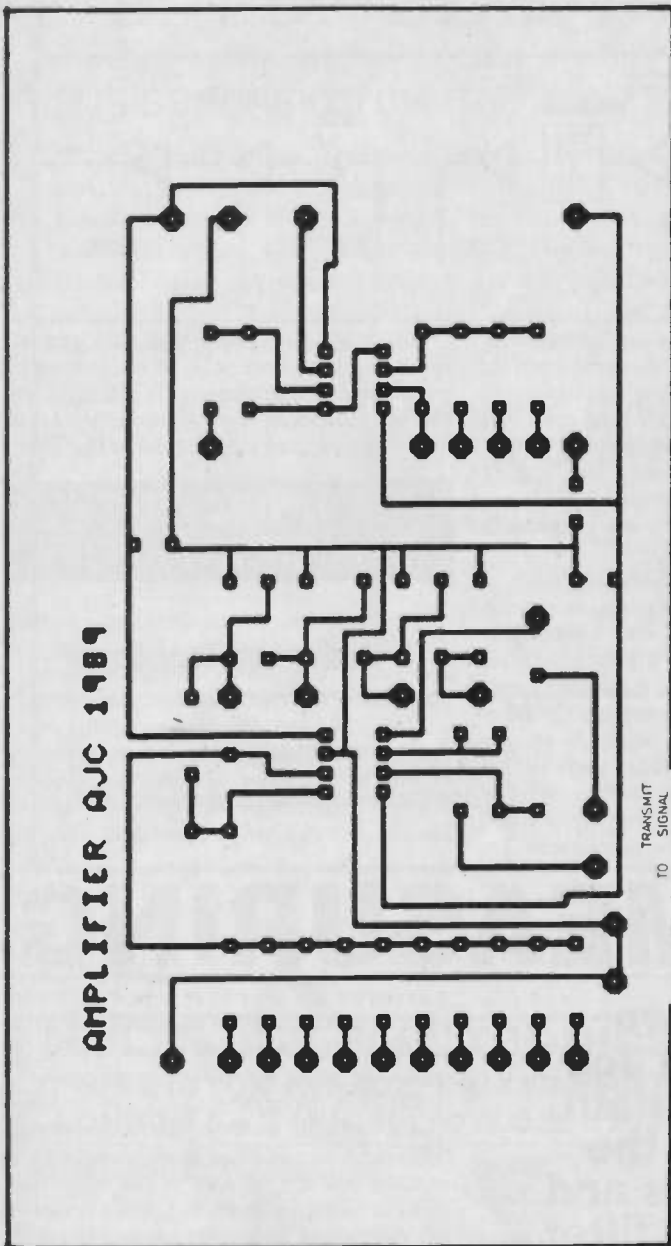

Fig 17. Track layout for transmit and receive amplifiers. When copying this and other tracks ensure that ic pin spacing is exactly 0.1 inch.

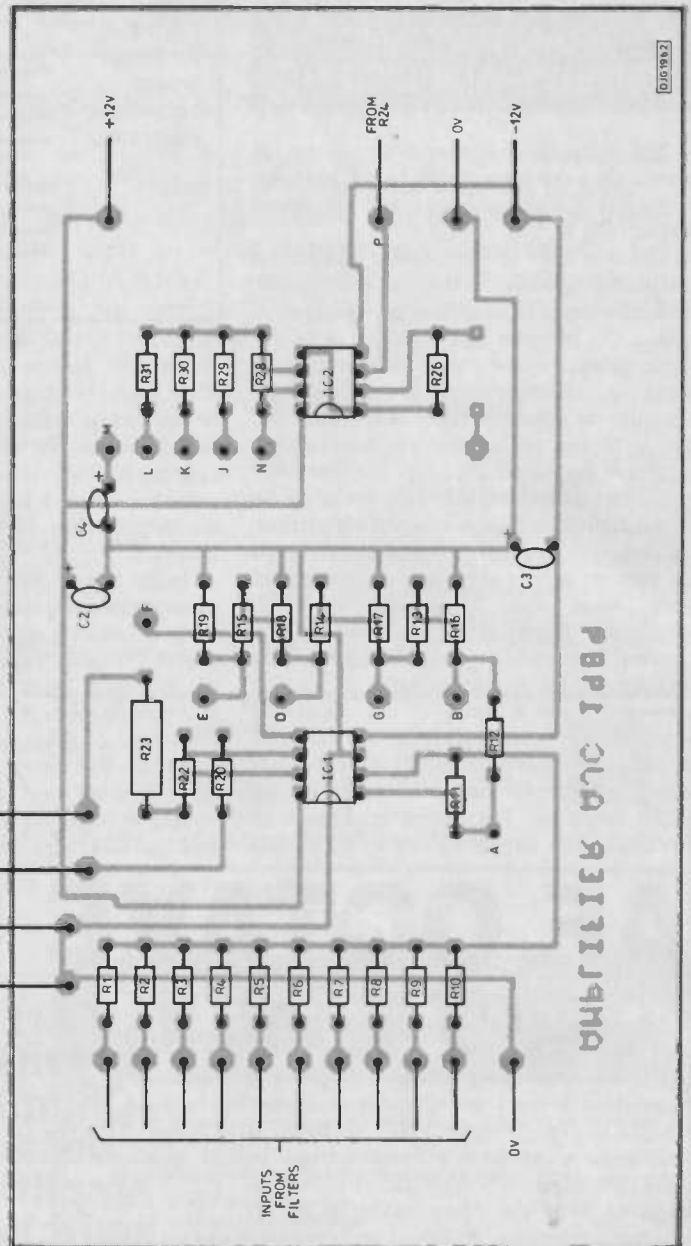

Fig 16. Component layout for transmit and receive amplifiers.

AMPLIFIER BOARD COMPONENTS

RESISTORS

R1-R10	100k (nominal value but see text) (10 off)
R11,R22	33k (2 off)
R12-R15	2k2 2% (4 off)
R16-R18	1k5 2% (3 off)
R19	1k 2%
R20	3k
R23,R27	600ohms 2% (2 off)
R25,R26	10k (2 off)
R28	100k
R29	47k
R30	11k
R31	3k3

All 0.25W 5% unless marked

CAPACITORS

C1	220n polycarbonate or polyester
C2,C3	22 μ 25V electrolytic (2 off)
C4	22 μ 6V tantalum

SEMICONDUCTORS

IC1,IC2 TL072 (2 off)

POTENTIOMETERS

VR21	10k log rotary
VR24	1M log rotary

SWITCHES

S1	2p6w make before break rotary
S2	3p4w make before break rotary
S3	spco toggle

MISCELLANEOUS

8 pin dil ic sockets (2 off)

intermodulation products generated by the switching signal (f_0) and its harmonics beating with the signal frequency (f_s). This produces signals having frequencies of f_0+f_s , f_0-f_s , $2f_0+f_s$, $2f_0-f_s$ and so on. If any of these products fall in the pass band of the filter spurious outputs will result. The same sort of effect can be seen with analogue to digital converters. In most cases, the problem can be resolved by putting a low pass filter in front of the active filter to prevent frequencies near the switching frequency reaching the filter input. As the switching frequency is 100 times the signal frequency a simple resistor-capacitor network will suffice for the transmit filters. Problems can also be experienced with components of the switching frequency leaking onto the filtered signal output. Spurious input signals to the transmit filters can be removed by inserting shunt capacitors across the driver board output attenuator, although with even moderate lengths of

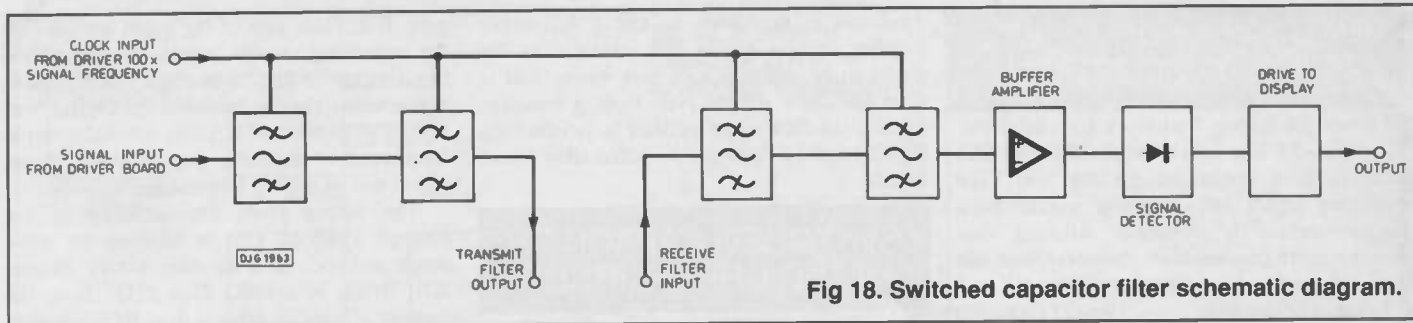

Fig 18. Switched capacitor filter schematic diagram.

screened lead to connect the driver to the filter such capacitors are generally unnecessary. The receive filters would require low pass filters on their inputs to achieve maximum accuracy but for the degree of resolution provided on the display this degree of complication is not necessary.

The schematic and circuit diagrams for the switched capacitor filter are shown in Fig. 18 and Fig. 19.

On the switched capacitor filter board the output spurious contents are removed by R7 and C1 for the transmit filter, and R14 and C2 for the receive filter. Although the switched

filters are designed to have a nominal pass band gain of unity there is still a danger that dc offset potentials may be present at the filter output, so to ensure that these do not cause errors in the precision detector circuit, an ac coupled buffer amplifier stage is used to isolate the detector. In other respects the detector and display circuits are similar to the analogue filter board.

The overall performance of the switched capacitor filter is similar to that of the analogue filter but some problems may be experienced with the highest frequency unit (12.8kHz) as the switching frequency for this

SWITCHED CAPACITOR FILTER COMPONENTS

RESISTORS

- R1,R3,R4
- R6,R8,R10
- R11,R13 100k 2% (8 off)
- R2,R5,R9
- R12 10k 2% (4 off)
- R7,R14 22k (2 off)
- R15 1M
- R16 56k
- R17 100k
- R18,R19 1k
- R20 4k7
- R21 22ohms

All 0.25W 5% unless marked

CAPACITORS

- C1,C2 see table
- C3 220n polycarbonate or polyester
- C4 2μ2 6V tantalum
- C5-C7 22μ 25V electrolytic (3 off)

SEMICONDUCTORS

- IC1,IC2 MF10 (2 off)
- IC3 TL072

MISCELLANEOUS

- NSM3915 10 element log bargraph display module
- 20 pin dil sockets (2 off)
- 8 pin dil sockets

FREQUENCY SENSITIVE CAPACITORS C1 AND C2

Frequency	Capacitor
25Hz	47n
50Hz	22n
100Hz	10n
200Hz	4n7
400Hz	2n2
800Hz	1n2
1600Hz	680p
3200Hz	330p
6400Hz	150p
12800Hz	68p

All 20% tolerance or better

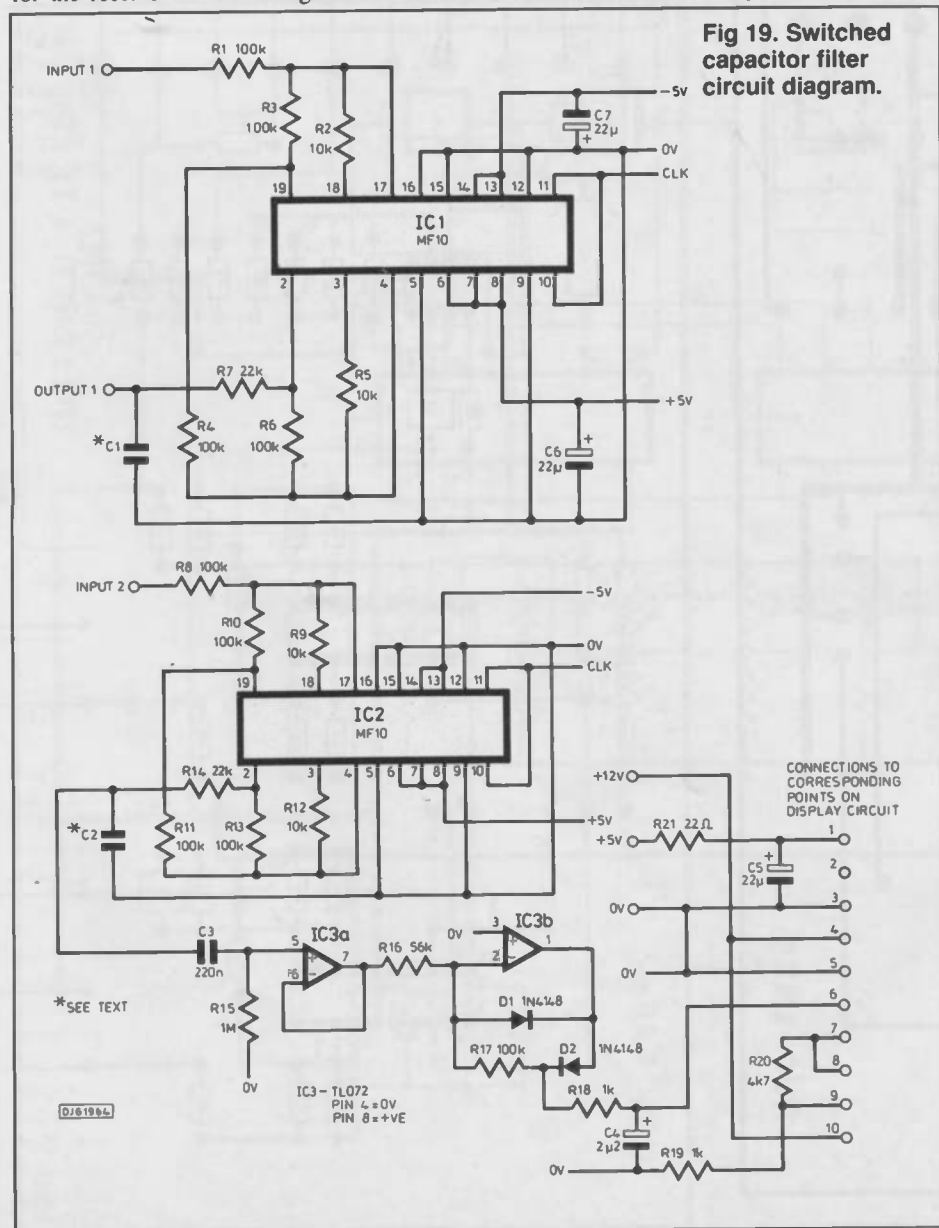

Fig 19. Switched capacitor filter circuit diagram.

is 1.28MHz which is reaching the limit for the specified performance of the MF10. It is possible to change the filter configuration to make it operate with a switching frequency of 50 times the tuning frequency by taking pin 12 to the +5V line instead of the 0V line. The filter is then controlled by the 640 kHz switching signal and a similar overall pass band response is obtained. Aliasing can become more of a problem, however, and the value of the low pass filter capacitors C1 and C2 should be doubled.

While on the subject of low pass filters, C1 and C2 are the only two components of the filter which have to be specially adjusted for different pass band frequencies. The frequency determining element being the switching frequency which is selected from the driver board.

The precision rectifier circuit is a half wave detector. Where asymmetrical signals are to be detected, for example speech or

music, it is necessary to use a full wave rectifier version but in this instance, as the signal to be detected is a sine wave (that is what the filter selects even from a complex signal), the half wave rectifier is satisfactory. Figs 20 and 21 show the switched filter board details.

SWITCHED CAPACITOR FILTER DRIVE CIRCUIT

The signal source and switching waveforms for the switched capacitor filters are derived from a slightly more complex circuit that is used for the analogue filters. The block schematic diagram of the driver board is shown in Fig.22 and the circuit diagram in Fig.23.

The primary signal source for this version of the driver is a 5.12MHz crystal controlled oscillator built around a 4011 quad NAND

gate, IC1. Only two of the gates are used so the remaining unused inputs are tied to the negative power line. A frequency of 5.12MHz was chosen simply because the crystal was readily available and is easily divided down in frequency to produce the required output signal and switching frequencies.

The output from the oscillator is fed through a second gate to improve the wave shape and then to a 12-stage binary counter IC3, which is a 4040. Output Q1 from the counter is used to drive a dual BCD counter, IC2, connected as a divide by 100 counter. Ten of the remaining outputs from IC3 (Q2 to Q11) are used at the clocking drives to the various filter stages. The output from the divide by 100 counter is connected to the input of a second 12-stage counter, IC4, the outputs from which form the signal sources for the filters. The output attenuators from each stage of IC4 are similar to those used for the analogue version except that provision is

Fig 20 and 21. Component and track layouts for the switched capacitor filter circuit.

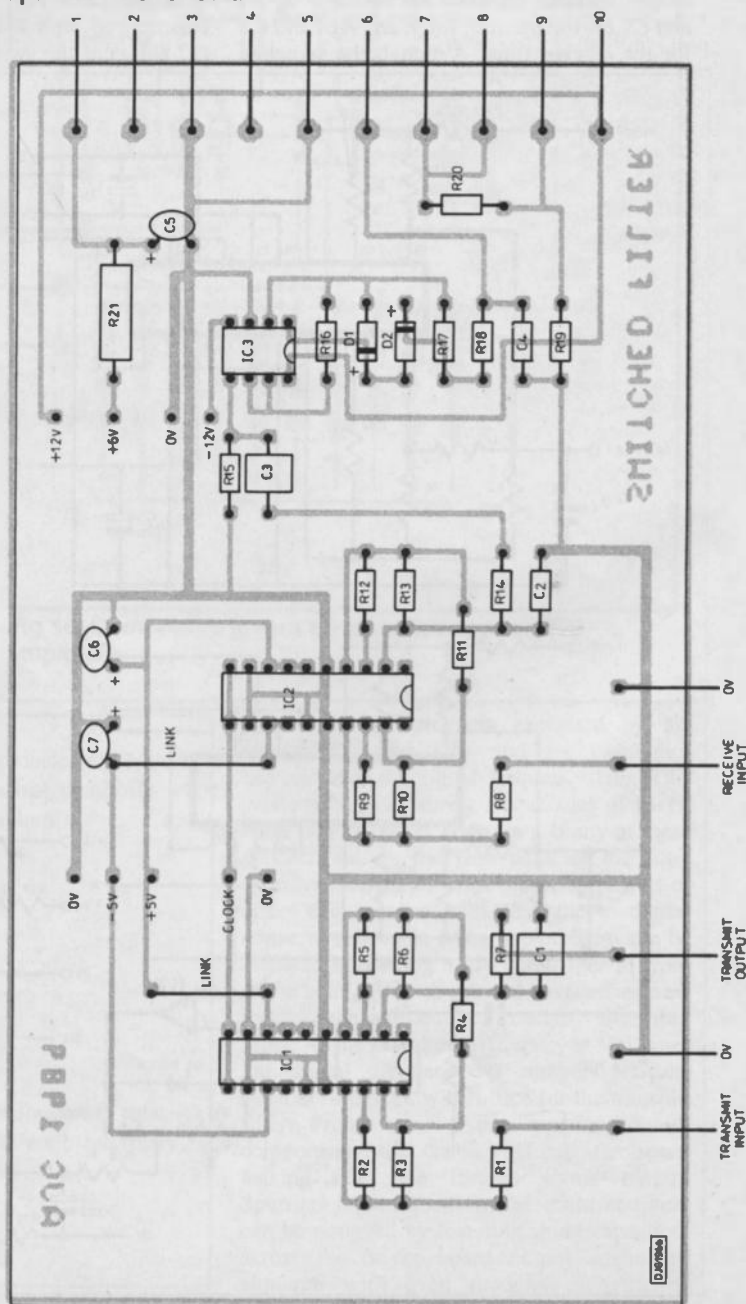
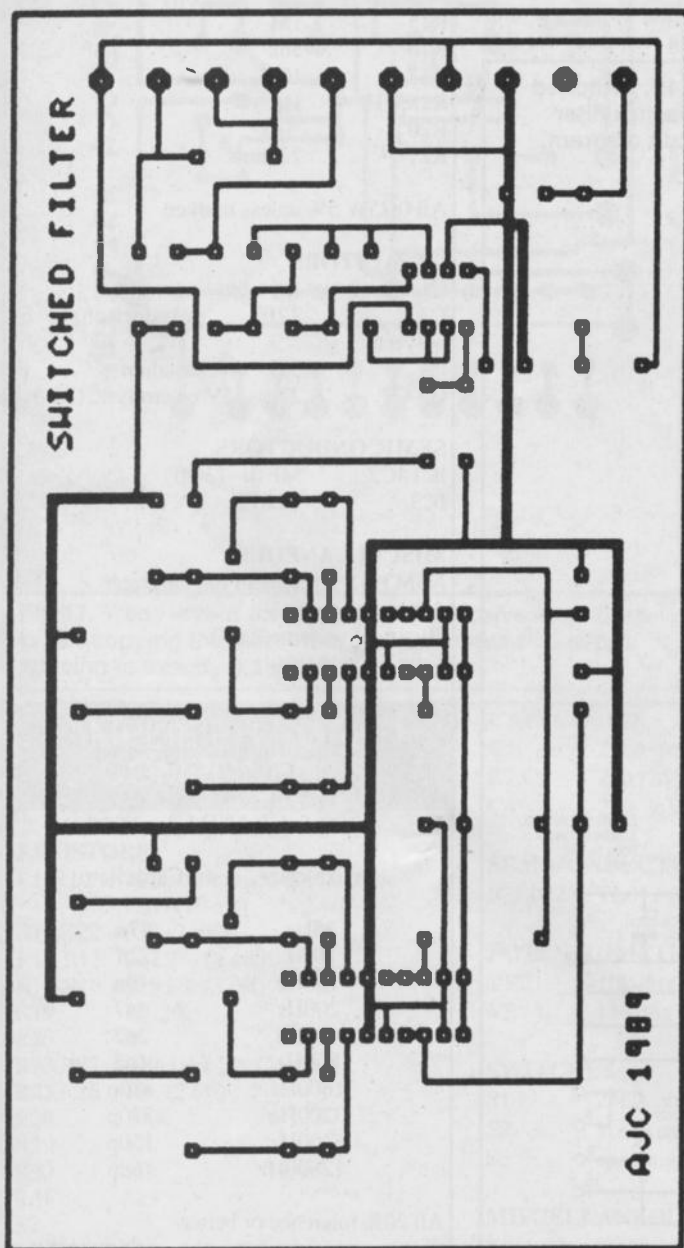
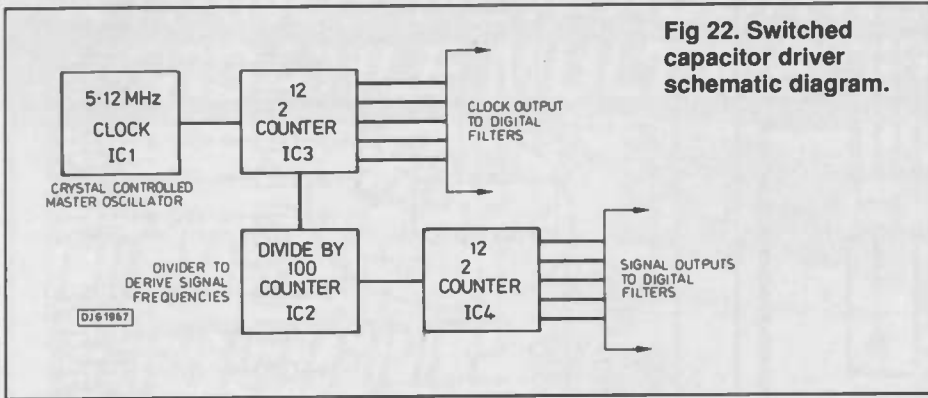

Fig 22. Switched capacitor driver schematic diagram.



made to incorporate a shunt capacitor to help with aliasing problems, although in practice, I have experienced no problems in the transmit filters with aliasing.

CONSTRUCTION

A minor difficulty in constructing the unit is in mounting the display devices and providing the connections to the filter boards.

I wired all the display units to a common board and then mounted the whole board on the front panel of the instrument. This works, but it is not a very elegant solution to the problem. It is probably better to mount the filter boards vertically behind the display modules and provide a flexible wiring harness between them.

It is important to use screened wiring to interconnect the various boards. Although the signal levels between the input and output of

SWITCHED CAPACITOR FILTER COMPONENTS

RESISTORS

- R1 330k
- R2-R21 10k (20 off)

All 0.25W 5% carbon or better

CAPACITORS

- C1-C10 same values as for C1 and C2 in the switched capacitor filter, depending on frequency (10 off)
- C11,C12 22 μ 25V electrolytic

MISCELLANEOUS

- X1 5.12 MHz crystal
- IC1 4011
- IC2 4518
- IC3,4 4040
- 14 pin dil sockets
- 16 pin dil sockets (3 off)

Fig 23. Switched capacitor driver circuit diagram.

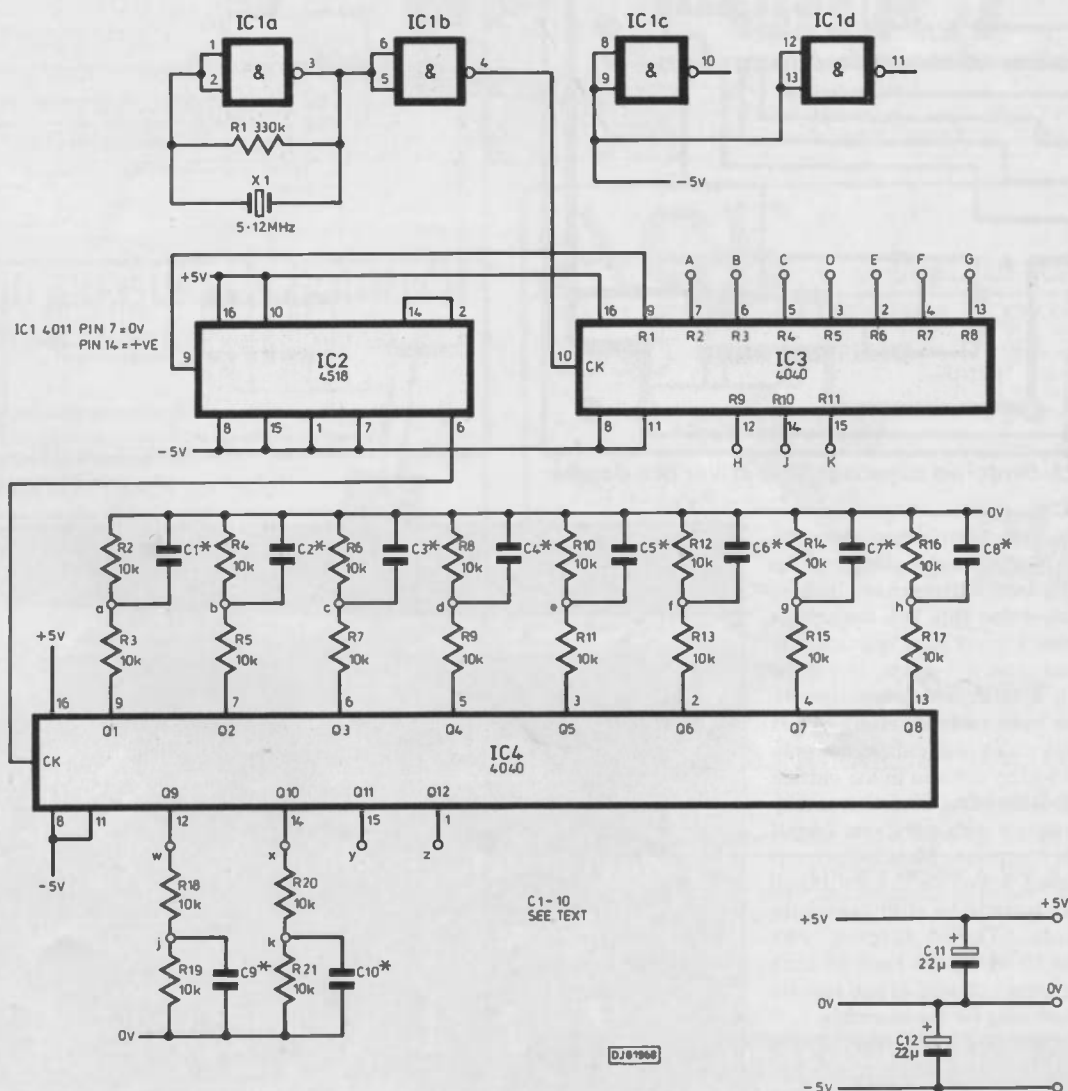

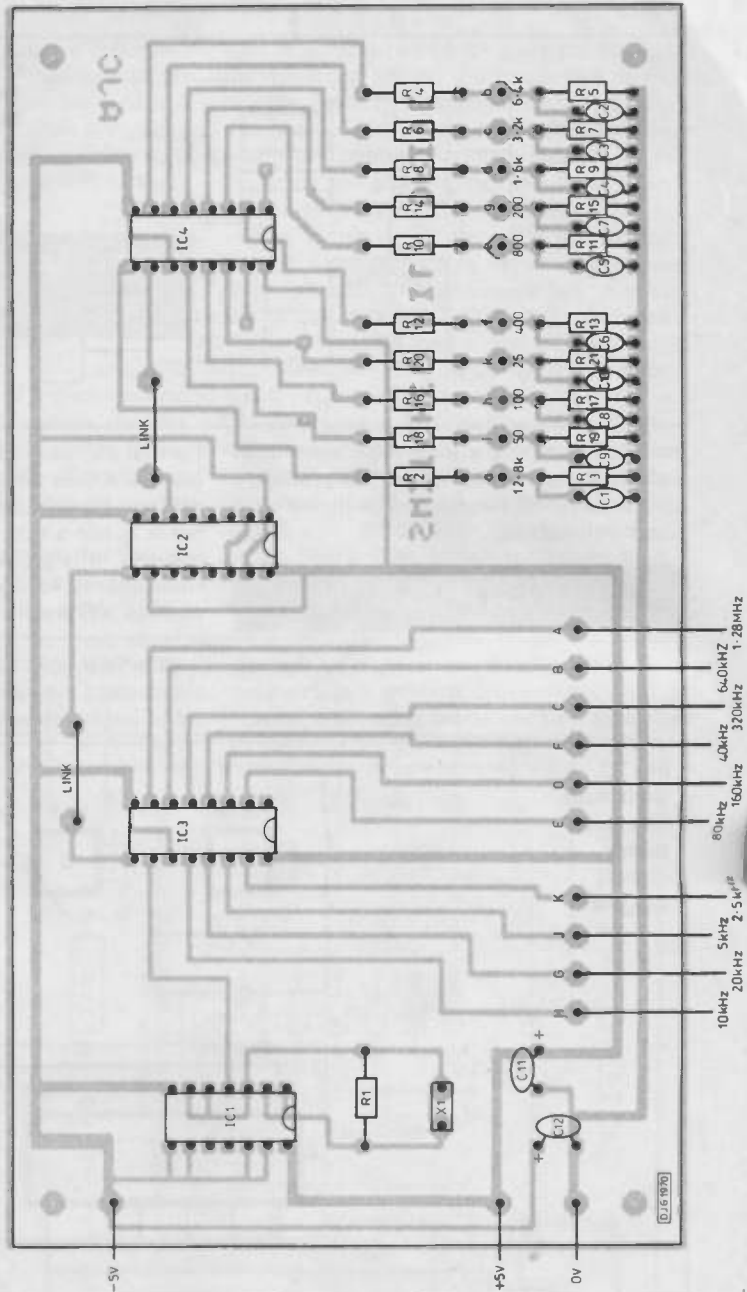
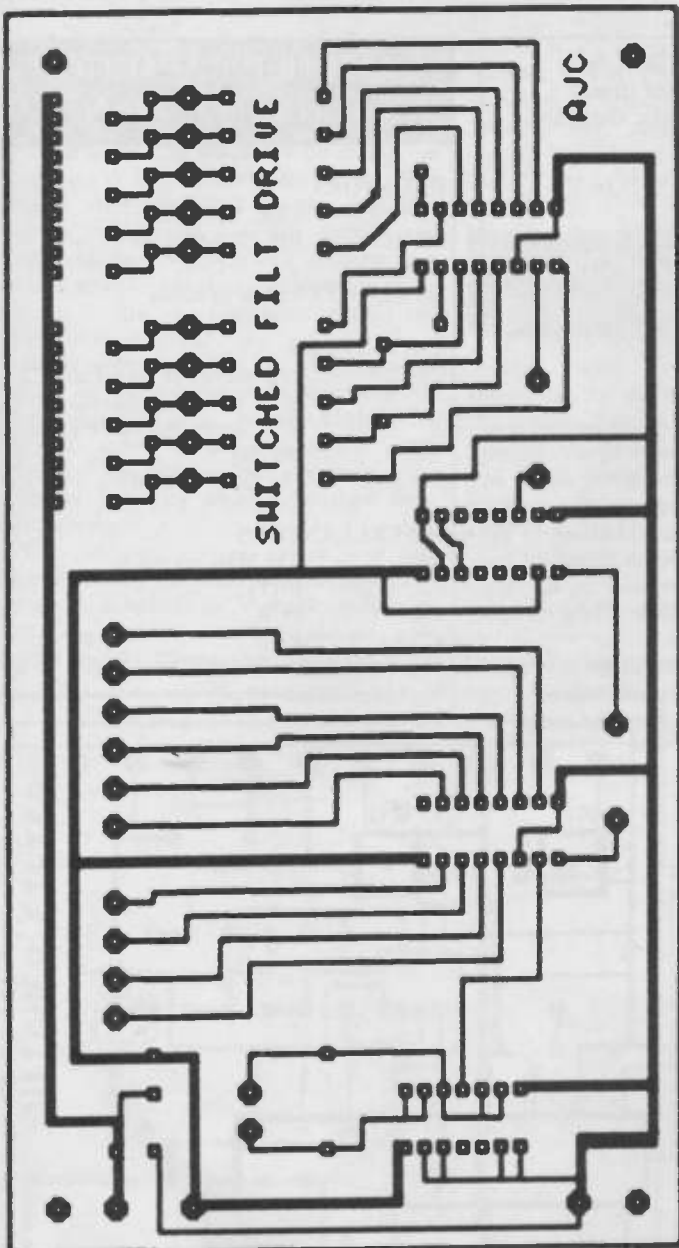

Figs 24 and 25. Switched capacitor filter driver pcb details.

the filter boards, for example, are about the same level there is considerable danger of the harmonics of the transmitter driver leaking into the output or, worse still, into the receive section. It is also a good idea, particularly with the switched capacitor driver, to put the drive circuit in a screened compartment. There are some very fast switching edges around this board which will radiate not only into the internal wiring but also to the outside world where, as with home computers, they can cause interference with television signals and/or fm radio reception. Metallic screens must be provided between the switched capacitor filter boards to stop crosstalk between boards. These screens can conveniently be fixed on the back of each circuit board by means of screws and spacers and serve as a mounting for the assembly.

The photo on the right shows the interior of the boxed unit.

Next month we shall give further constructional information plus details of the power supply and alignment.

PE

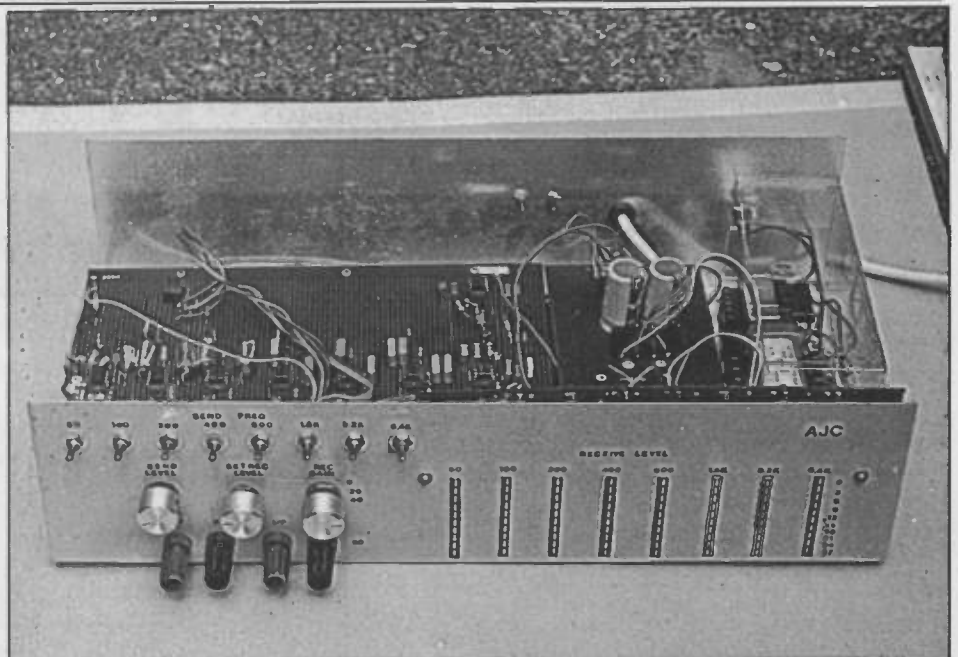

A HANDY NEW ADDITION TO OUR VERSATILE MULTIMETER RANGE

£38.⁹⁸ inc. VAT
please add £1.00
for p+p

DIGITAL CAPACITANCE METER

An extremely useful hand-held capacitance meter measuring from 1pF to 20,000µF in nine ranges.

Features include:

- 13mm, 3.5 digit LCD
- Zero adjustment
- Low battery indicator
- One year warranty
- Supplied with battery (PP3), manual and test leads
- Just one of our many low cost Digital Multimeters - send for full details



Specification

ranges	res.	accuracy
200pF	0.1pF	+ (0.5% + 1 digit + 0.5pF)
2nF	1.0pF	+ (0.5% + 1 digit)
20nF	10pF	+ (0.5% + 1 digit)
200nF	100pF	+ (0.5% + 1 digit)
2µF	1.0nF	+ (0.5% + 1 digit)
20µF	10nF	+ (0.5% + 1 digit)
200µF	100nF	+ (0.5% + 1 digit)
2000µF	1µF	± (1.0% + 1 digit)
20,000µF	10µF	+ (2.0% + 1 digit)

Overload protection	0.25A 250V fuse
Excitation voltage	3.2V, all ranges
Dimensions	180 x 85 x 38mm

OUT NOW!

- The new Cirkuit Catalogue
- 184 pages
 - Discount vouchers
 - 1,000's of products



Cirkuit

£1.60 inc.

SAME DAY DESPATCH - 0992 444111

Cirkuit Distribution Ltd.
Park Lane, Broxbourne, Herts. EN10 7NQ
Tel. Enquiries (0992) 441306 Fax. (0992) 464457

HAND HELD FREQUENCY COUNTER

INTELLIGENT INSTRUMENT FOR PROFESSIONAL USE

MODEL 1300 H/A

Frequency range from 1Mhz to 1.3Ghz
Sensitivity: 1 - 10 Mhz : 10 - 150mV, rms
10 - 100 Mhz : 1 - 50mV, rms
1 - 1.3 Ghz : 10 - 80mV, rms



MODEL 2400H

Frequency range from 10Mhz to 2.4Ghz
Sensitivity: 10 - 60 Mhz : 10 - 150mv,rms
60 - 2 Ghz : 3 - 100mv, rms
2 - 2.4 Ghz : 5 - 100mv, rms



ACCURACY +/- 1 PART PER MILLION 25 TO 35 DEGREES C.TCXO TIME BASE IS STANDARD.

ALL COUNTERS HAVE 8 DIGIT RED .28" LED DISPLAYS. ALUMINIUM CABINET IS 3.9" H x 3.5" W x 1". INTERNAL NI-CAD BATTERIES.

A FULL LINE OF ANTENNA, CARRYING CASE, AND ACCESSORIES IS AVAILABLE.

ONE YEAR PARTS AND LABOUR GUARANTEE

DAVE TRONICS LTD
330 KILBURN LANE
LONDON W9 3EF
TEL: 081 968 0227
FAX: 081 968 0194

AGE

A & G ELECTRONICS LTD.

ELECTRONIC COMPONENTS MAIL ORDER COMPANY.

1990 COMPONENTS

Lowest prices for quality components.

CATALOGUE IS

AVAILABLE NOW.

summer special

This offer is for a limited period.

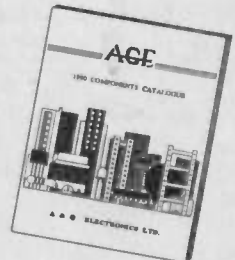

Dont miss out !!!

Order a catalogue now and we send you a

0.5" ORANGE DUAL LED DISPLAY

Value £ 2.00 absolutely free !!!

Simply complete and return the order form below and we will send your free gift.

PLEASE SEND COPIE(S) OF THE A & G ELECTRONICS CATALOGUE AT £1.00 (REFUNDABLE WITH MY FIRST ORDER) AND MY FREE GIFT(S) TO :

NAME

ADDRESS

.....

I HAVE ENCLOSED £

A & G ELECTRONICS LTD.

Free Post ,100 Park Avenue ,

London E 6 2BR. (No Stamp Required)

TEL : 081-552 2386 Fax : 081 - 519 3419.

EASY-PC, SCHEMATIC and PCB CAD

**NEW VERSION:-
NOW DRAWS EVEN FASTER!**

**Only
£98.00**

**BRITISH
DESIGN
AWARD
1989**

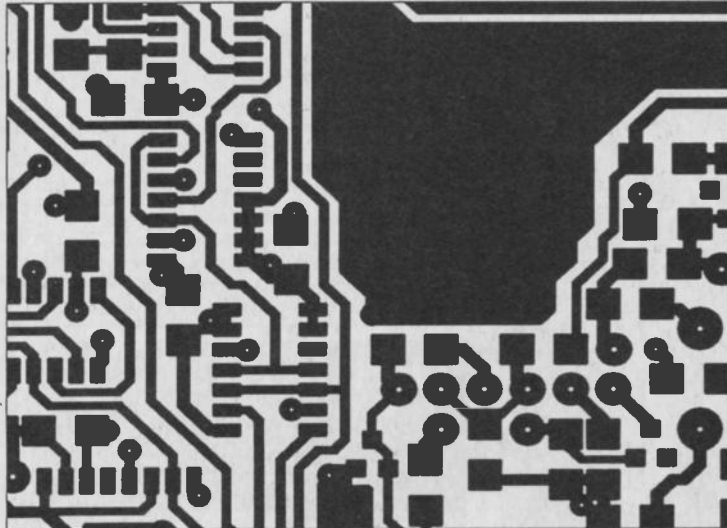

Also:- over 400 Symbols!

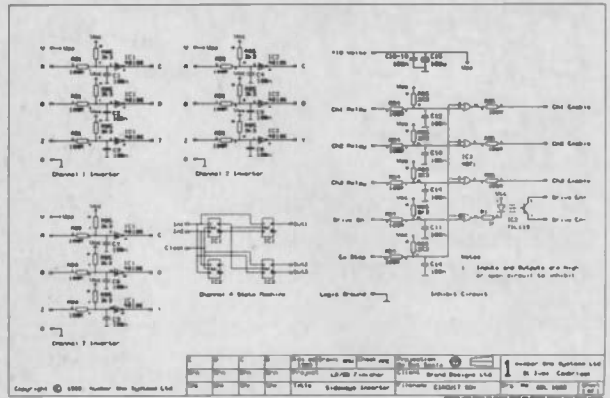

Fast Professional Quality Output - Affordable Price

SMITH CHART PROGRAM – Z-MATCH II

For IBM, PC/XT/AT and clones.

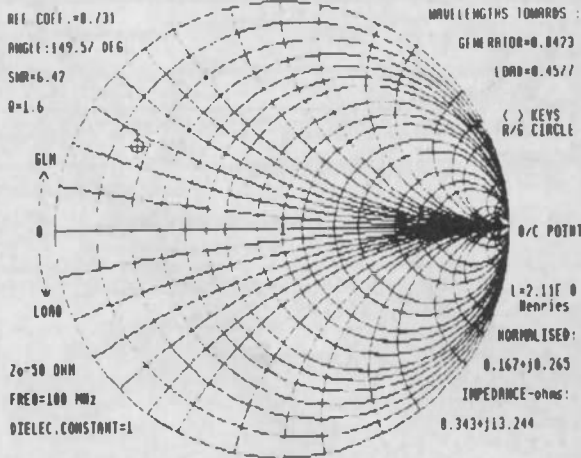

Z-MATCH – Takes the drudgery out of R.F. matching problems. Includes many more features than the standard Smith Chart. Provides solutions to problems such as TRANSMISSION LINE MATCHING for AERIALS and RF AMPLIFIERS with TRANSMISSION LINE TRANSFORMER and STUB MATCHING methods using COAXIAL LINES MICROSTRIP, STRIPLINE and WAVEGUIDES. The program takes account of TRANSMISSION LINE LOSS, DIELECTRIC CONSTANT, VELOCITY FACTOR and FREQUENCY. Z-MATCH is supplied with a COMPREHENSIVE USER MANUAL which contains a range of WORKED EXAMPLES £195 for PC/XT/AT etc

CIRCUIT ANALYSIS BY COMPUTER – ANALYSER II

For IBM, PC/XT/AT and clones.

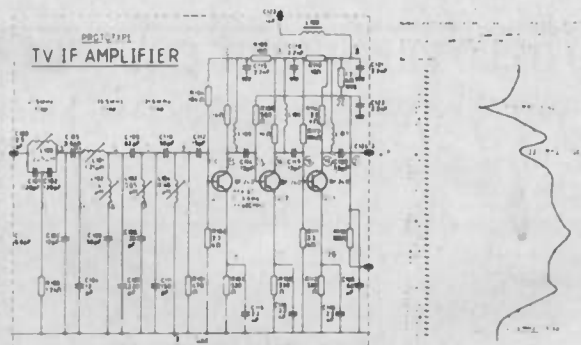

"ANALYSER II" – Analyses complex circuits for GAIN, PHASE, INPUT IMPEDANCE, OUTPUT IMPEDANCE and GROUP DELAY over a very wide frequency range. Ideal for the analysis of ACTIVE and PASSIVE FILTER CIRCUITS, AUDIO AMPLIFIERS, LOUDSPEAKER CROSS-OVER NETWORKS, WIDE-BAND AMPLIFIERS, TUNED R.F. AMPLIFIERS, AERIAL MATCHING NETWORKS, TV I.F. and CHROMA FILTER CIRCUITS, LINEAR INTEGRATED CIRCUITS etc. STABILITY CRITERIA AND OSCILLATOR CIRCUITS can be evaluated by "breaking the loop". Can save days breadboarding and thousands of pounds worth of equipment. £195 for PC/XT/AT etc.

Write or 'Phone for full details:-
Number One Systems Ltd.

REF:PE, HARDING WAY, SOMERSHAM ROAD, ST.IVES, HUNTINGDON, CAMBS, PE17 4WR, ENGLAND.
Telephone: 0480 61778 (6 lines) Fax: 0480 494042

The CAD Specialists

ACCESS, VISA, AMEX Welcome.



There can be few people who have made as many inventions as Edison. He was one of the most exceptional inventors there has ever been, and at one time he was making a new invention about every week. During the whole of his life he took out well over one thousand patents, many for inventions which are in every day use even now.

BIRTH

Thomas Alva Edison was born on the 11th February 1847 in a town called Milan, in the state of Ohio, USA. His father, Samuel Edison was a harsh man who often beat his son. This and his hearing disability resulted in the young Edison being backward at school. In fact, his formal schooling only lasted for three months before he was expelled because he showed no educational ability. Fortunately, his mother, Nancy could see more ability in the boy and she continued to teach him at home. She proved to be very successful because she brought his inquisitive nature to the fore. She even went as far as building a small chemistry laboratory in the basement of their house for him. This proved to be very successful because Edison was able to perform his own experiments and observe many scientific

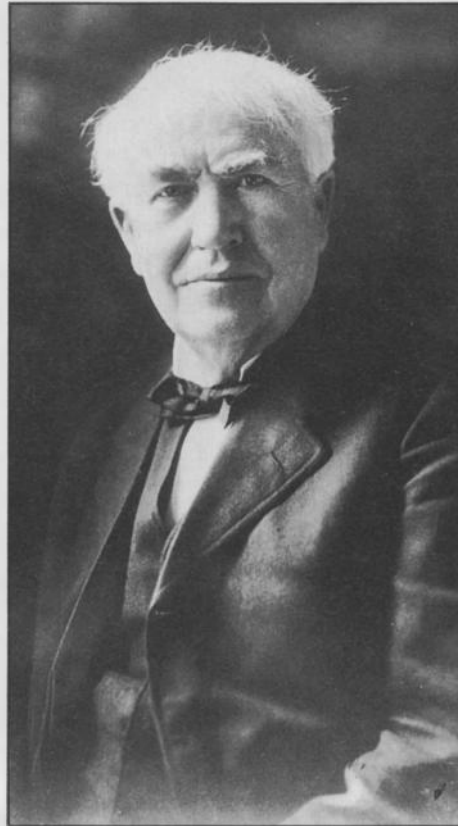

LABORATORY MOVES

Edison's set-up at Newark was not ideal for him in a number of ways and he soon found the need to move. As a result, he decided to set up a new laboratory, but this time in a village called Menlo Park which was also in New Jersey. He took with him a number of the skilled men from Newark and before long inventions of all sorts were turning out of the new laboratory.

Here he made a tremendous number of inventions and some of the more innovative ones like the phonograph gained him recognition all over the world. In fact, Edison aimed all his work at ideas which would have an application and could be sold. This is a major reason for his success. There were even larger projects on the horizon.

LIGHTS IN THE DARKNESS

At this time, the vast majority of lighting was by gaslight. Edison saw that it might be possible to use electricity to fulfil this role. If it was possible, he

EDISON

effects. It also started to bring out his interest in electrical and mechanical devices. He even made some batteries himself and carried out a number of tests and experiments with them.

IN BUSINESS

Money was short in the Edison house and his father earned very little. As a result, Edison himself went out and started to earn some money himself at the age of 12. He did this by selling newspapers on the trains which ran in the district. As he had to sell them on board the trains and had plenty of spare time on his hands he did plenty of reading and he even set up a small laboratory on the train. He later looked back on these times as the happiest days of his life.

As he grew older, Edison trained himself to use the new telegraph systems which were just beginning to be introduced and between 1863 and 1868 he earned his living as a roaming telegraph operator, even operating behind the enemy lines in the civil war.

During this time he kept up his reading, buying a copy of one of Faraday's books. Inspired by the book he decided to become an inventor. This idea soon started to become reality when he took out his first patent in 1868.

Photograph Courtesy of The Institution of Electrical Engineers.

Ian Poole highlights how Edison's prolific ideas resulted in many patents, and an invention-factory, but that the semi-conductor effect, though observed, was never exploited.

THE TIDE TURNS

The year 1869 saw Edison down and out. He was unable to secure a steady job despite the fact that he was looking for one, and his money soon ran out. He had to resort to any small jobs he could find. One which he came across was to repair a telegraphic "tic-a-tape" machine. This he did so well that the company asked him to stay on to repair other machines when they stopped working. Edison soon settled in and true to style he even modified and improved a new printer which was just coming into use. This earned him the enormous sum of \$40,000 from the manufacturer and with this he was able to set himself up in business as an inventor in Newark in New Jersey. This was what he enjoyed most of all and soon his laboratory started to produce a number of useful inventions and improvements, most of which were related to the telegraph.

thought, it would be far more convenient, flexible and safe. However, there were tremendous problems to overcome as nobody had built a large electrical system at this time, at least not one on a scale to compete with gas lighting. Undaunted, in 1878 Edison started to devote his energies to devise a system which could do this.

The first hurdle he had to overcome was to raise sufficient money for his research and an initial system. This did not present too much of a problem as his past record meant that he was a fairly safe risk for the banks and he soon raised £300,000. Then he set up a new company specifically for the research into his lighting project. This he called the Edison Electric Light Company, but later he also set up other companies to manufacture and sell the lights and systems.

Next he had to devise how he would actually organise the lighting system. Very basic decisions, like the voltage and whether bulbs would be run in parallel or in series, all had to be made. In addition to this, new bulbs had to be developed which would be reliable over long periods of time. At this time a number of incandescent bulbs had been made but their life was very short. The only other form of electric light at the time was the carbon arc lamp and this was far too large and bright for domestic households.

The development was carried out with the utmost urgency as Edison wanted his

Continued on page 45



HOME-BASE

This month and next I'm concentrating entirely on the Summer Consumer Electronics Show which was held in Chicago.

Summer CES is a smaller affair than the Las Vegas based Winter event held each January, but that didn't rule out any interest in Chicago. An estimated 70,000 visitors attended CES this time, to see the exhibits from over 1,000 companies.

Sony's founder and living legend, Akio Morita, gave an inspirational keynote speech looking back over the history of consumer electronics and he stressed the importance of the relationship between consumer electronics manufacturers and the providers of



Akio Morita, founder of Sony

Ian Burley strides into the future at the Summer Consumer Electronics Show

"software" - music and video recordings, for example, which bring all the gadgets to life. Morita humbly admitted that Sony had been forced to learn from its mistakes when the video recorder first appeared on the scene. Sony Beta machines were generally considered to be technically superior compared with the competition, but Sony failed to gain software industry support for the Beta format until it was too late. Today, Sony makes VHS recorders, based on the standard developed by its rivals.

An example of conflict today is that hifi manufacturers are still at sixes and sevens with the music software industry. Digital audio tape was ready for the market several years ago, but the record industry's piracy paranoia has meant its refusal to support dat with pre-recorded software. This has put the future of dat in jeopardy. Akio Morita looks forward to a time when electronics manufacturers and the Arts work in harmony. The successful introduction of music compact disc technology is a happy example of successful cooperation. Morita, whose company exhibited at the first CES event 40 years ago, even cheekily suggested that one day CES might stand for the Consumer Entertainment Show.

GOODIES

So what goodies pulled the crowds in Chicago this year? In January the CES organisers promised the attraction of high definition television. In the end only Barco actually had any hardware to show and that was only prototype a hdtv video projector. This time we weren't disappointed. Toshiba and Panasonic turned up with hdtv demos on their impressive stands and Barco announced the availability of its hdtv projector.

JVC, Sony, Olympus and Panasonic were showing tiny hand held camcorders with advanced features and a degree of "artificial intelligence" built in. With FCC approval now granted, US households will be able to link televisions, videos and video cameras around the home with short range household wireless broadcasting accessories. There was news of the American quest for a comprehensive set of home-automation standards.

Computer firm, Commodore, stole a hefty chunk of the lime-light with the unveiling of its cd rom based multimedia machine, called cdtv. Based on Commodore's Amiga computer technology, do we have a serious threat to the aspirations of Philips' cd-i in the leisure multimedia stakes?

We also had a good look at the latest electronic personal organisers, translators, encyclopaedias, phone accessories, electronic games and more; read on:



Commodore Amiga with infra-red mouse, tracker ball and remote control

CDTV

First of all, Commodore's cdtv effort. While Philips and Motorola finally ready themselves for a cd-i assault on the fledgling home multimedia market next year, Commodore has decided that the waiting has gone on long enough. With some undoubted inspiration from the original inventor of the video game and founder of Atari, Nolan Bushnell, Commodore has put together a cd-rom player married to Amiga computer technology which Commodore confidently predicts will thwart cd-i before that gets off the ground.

Using the Amiga's impressive video chips, the cdtv will be able to display and manipulate full colour high resolution computer images and video stills as well as chunks of motion video. The ISO 9660/High Sierra cd rom standard is used and the player will also read cd+g (cd with graphics) discs and play standard music cds.

The success of cdtv rests in its software support. A cd rom disc has a 550Mb capacity, or 250,000 pages of text, or up to 14 hours of sound - depending on the sampling rate, or several hundred full-screen uncompressed pictures. The software companies will hopefully take these attributes and produce multimedia encyclopaedias, interactive learning courses, games with huge scenarios and life-like graphics and, and much more. Theoretically, multimedia systems like cdtv and cd-i are only limited by the imagination.

The central cdtv unit is a rather anonymous and conventional looking front-loading cd player, though the discs actually load in a protective cartridge. It wouldn't look out of place in a hifi stacking system. The entry level just includes a relatively simple infra-red remote control. With this you will be able to use the cdtv as a music cd player and look around the contents of a cd rom application. Options will include:

a mouse, tracker ball, joysticks, external floppy disc drive and a computer keyboard. It will be possible to expand the cdtv to near enough the specification of a Commodore Amiga 500 computer. Commodore also promises an Amiga computer to cdtv specification upgrade kit.

The cdtv is not intended to be a technical competitor with cd-i. The latter will offer full screen digital motion video with the help of some technically very advanced hardware. Commodore has to make do with software driven motion video for the cdtv, though this was not demonstrated at CES. Nonetheless, Commodore is about a year ahead of Philips in getting its product to market, assuming the promised September shipping date is met and you get a very useful computer into the bargain. The cdtv is expected to sell for around £500-£600, about the same price as Philips' predictions for the first cd-i machines which aren't due until the middle of next year. The multimedia revolution is already hitting the computer industry hard. 1991 will see multimedia coming of age in the home too.

HDTV

I have been very fortunate to see high definition tv for myself. The pin-sharp wide-screen image offered by hdtv is quite remarkable when compared to conventional tv, especially the very tired American NTSC standard. At CES this time, lots more people were granted the privilege of being able to wonder at hdtv for the first time courtesy of Toshiba and Panasonic. The former was content to show an hdtv video played back continuously on an hdtv monitor, while Panasonic showed a rear-projector and a picture filing system using hdtv. In Japan, several "art galleries" have opened up which display artistic treasures through the hdtv medium. Panasonic showed a 12" optical disc used for recording still images and moving sequences rather like an over grown cd-i system. Round the corner, hdtv monitors were hooked up to a computer system with image digitizers and colour printers.

Both Toshiba and Panasonic drew awe-struck crowds. Barco ran basically the same hdtv projector demo in a small private theatre I saw back in January. Second time around, the magic when the hdtv projector took over from the NTSC one, in mid presentation, was just as intoxicating, especially with a little help from the superb Fosgate surround sound system used.

Representatives from the huge French Thompson television manufacturing group attended the show but didn't have a stand. It's Thompson's aim to introduce an intermediate hdtv or advanced tv which incorporates the wide-screen dimensions of the Japanese hdtv proposed standard but without the expense of very ambitious definition specifications. Meanwhile, the American television industry remains fearful that unless it organises itself quickly, it may not have a say in the standard setting for hdtv. Unfortunately, it's still difficult to predict exactly when hdtv will hit the consumer - 1995 seeming to be the majority guess.

More next month!

Ian Burley is the News and Features editor for BT Micronet, an on-line computer and technology magazine published on Prestel by British Telecom.

Panasonic HDTV back projector



Remember the new
Component Catalogue
available from
early 1990

CRICKLEWOOD ELECTRONICS

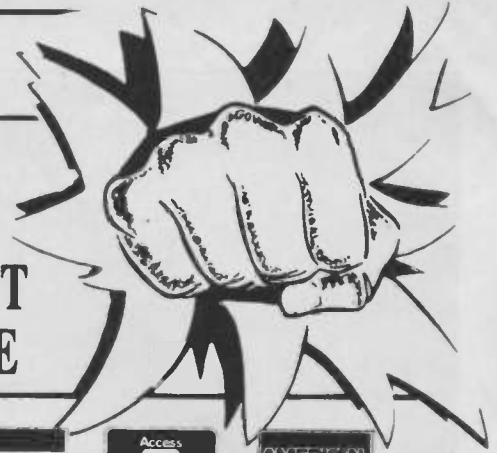

**BIGGER
AND BETTER**

**1990 COMPONENT
CATALOGUE**

- ONE OF THE LARGEST RANGES OF COMPONENTS IN THE UK
- FAST AND EFFICIENT SAME DAY PERSONAL SERVICE
- VERY COMPETITIVE PRICE; QUANTITY DISCOUNTS AVAILABLE
- DISCOUNT VOUCHERS INCLUDED
- NO MINIMUM ORDER

CRICKLEWOOD SUPPLY MOST OF THE COMPONENTS FOR P.E. PROJECTS. 13,000 STOCKLINES (MANY UNOBTAINABLE ELSEWHERE) PLEASE PHONE US FOR YOUR SPECIFIC NEEDS.

FILL IN THE COUPON AND POST IT WITH YOUR CHEQUE, PO ETC FOR £1.50 TO RECEIVE YOUR 1990 CRICKLEWOOD ELECTRONICS CATALOGUE AND VOUCHERS WHICH YOU CAN USE AGAINST YOUR NEXT PURCHASE

Cricklewood Electronics Ltd
40 CRICKLEWOOD BROADWAY, LONDON, NW2 3ET
Tel: 081-450 0995/452 0161
Fax: 081-208 1441 Telex: 914977

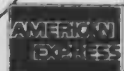

TELEPHONE ORDERS OUR SPECIALITY

CRICKLEWOOD ELECTRONICS 1990 COMPONENTS CATALOGUE

PLEASE SEND COPIES OF THE 1990
CRICKLEWOOD ELECTRONICS CATALOGUE AT
£1.50 TO:

NAME

ADDRESS

Remittance enclosed £

BRIAN PRICE BOHM ORGAN STUDIOS

66 Ashchurch Drive, Wollaton, Nottingham NG8 2RA
Telephone/Fax: 0602-284766

33 years of experience in high quality Organ and Keyboard design
behind every BOHM product.

The LATEST from BOHM 900/910 Series Organs

- ★ 400 sounds in NEW BOHM H.D.S. System
- ★ 256 Sampled Rhythms and Accompaniments
- ★ 22 Track Sequencer
- ★ Touch-Sensitive keyboards 49 Notes
- ★ All features fully Programmable by user, Soundcard or Optional Floppy Disc.
- ★ Available in choice of cabinets and Veneers.

520 Expander

- ★ Full Organ features. Stereo Voicing
- ★ Sound Sampled Rhythms
- ★ Fully Programmable from Soundcard

STATION ONE EXPANDER

- ★ All features of 900 Series Organs
- ★ Plus 48 track sequencer
- ★ Unlimited Programming facilities for Sounds, Rhythms and Accompaniments
- ★ Storage on soundcard, Floppy Disc, Hard Disc or very large Internal memory
- ★ Supplied with 400 Sounds and 120 Rhythms.

We are also the UK suppliers for the BOHM IC ES10.
Available with full Technical Information.

Supplied in kit form or built by:
THE BOHM SPECIALISTS

Part Exchanges welcome. Please write or phone for NEW English brochures and price list. — Callers by appointment please.

Contact your local agent:

South Wales:
Vernon Pursall
66 Colcot Road
Barry
South Glamorgan
Tel: 0446-733277

Scotland:
Keyboard Services
9 Kingswood Road
Kingswell
Aberdeen
Tel: 0224-744585

North West:
Nick Stammers
Westling, Tenfields
Heaton Le Hole
Tyne and Wear
Tel: 091-526 3589



Happy Memories

4116	150ns	only pulls	£1.00	2716	450ns	5 Volt	£3.20
4164	100ns	64K x 1	£1.25	2532	450ns	Only pulls	£3.50
41256	100ns	256K x 1	£2.25	2732	450ns		£2.15
41464	100ns	64K x 4	£2.75	2764	250ns		£2.15
44256	100ns	256K x 4	£7.50	27128	250ns		£2.25
41000	100ns	1024K x 1	£6.95	27256	250ns		£2.45
6116	150ns	Low power	£1.45	27C256250ns			£2.45
6264	100ns	Low power	£2.45	27512	250ns		£4.75
62256	100ns	Low power	£5.95	27C512250ns			£4.75
SIMMS	100ns	1 Meg x 9	£75.00	and 80ns			£79.00

Please call for prices of other chips. Same chips but different speeds, quantity discounts etc. Second (pulled) chips available for many of the above devices at substantially lower cost. Call for availability and price of these and other items.

Low profile IC sockets:	Pins	8	14	16	18	20	24	28	40
	Pence	5	9	10	11	12	15	17	24

We always have a large quantity of surplus computer equipment for sale; printers, disk-drives, add-on boards, monitors etc. Please ask for our surplus equipment list or call with your requirements as new items are added so frequently the list is never up to date!

Please add 50p post & packing to orders under £15. VAT to be added to total. Access orders by phone or mail welcome. PLC, government & Educational orders welcome for minimum invoice value of £15 net.

HAPPY MEMORIES (EL), FREEPOST,
Kington, Herefordshire. HR5 3BR.
Tel: (054 422) 618 Sales, 628 fax



(no stamp needed unless first-class required)





By now you should have completed the pcb assembly and are urgently awaiting the control wiring details. Fig.10 reveals all!

INITIAL TESTING

The only setting up that needs to be done is that of VR3, plus the scope sync, time-base, and amplitude settings. As said last month, VR3 should be adjusted for satisfactory display height while watching the screen. On my own scope, the amplifier input amplitude control was set on the 0.5V/cm range to give adequate screen coverage. The choice may vary depending on your scope. The dc setting is preferable to the ac one if you have a choice on this aspect.

Since the illusion of eight traces depends on scope time-base speed and sync, these will need adjusting on the scope in order to see the data correctly. First connect the scope's signal probe to the trace output socket, SK1, and set the scope channel amplifier for the range which will allow a swing of about 3.5V to just about fill the screen vertically. Set the time-

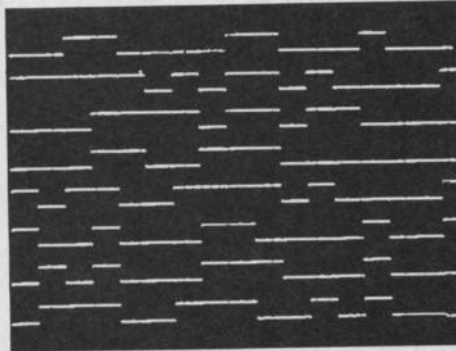

Photo 3: Typical traces photographed on the author's oscilloscope and generated using this project coupled to an 8-bit logic source.

derived from the external clock source. Switch S3 up so that IC9b will be triggered by the NAND gate IC6. Switch S2 up to hold the system at reset. Switch all address line switches S4-S10 upwards, so setting the memory to the lowest data block address once sampling has been completed. Turn VR1 fully anticlockwise, so that no signal data will be superimposed on the output ramp waveform.

Now switch S3 down allowing the sampling routine to commence on the first available input clock pulse. Observe the scope screen. The rate at which this shows trace changes will depend on the input clock rate. Providing it's of a reasonable speed, of say, at least 2-3kHz, you will see the scope trace gradually step up the screen, perhaps jerking slightly between steps. Having reached the top of the scope screen, the trace will drop back down again, and start climbing once more. It will repeat this action several times until the full count sequence has been completed.

MULTIPLE DISPLAY

At the end of the sequence you should see the screen jump to display several traces simultaneously. The actual apparent quantity may vary at this time until the scope controls are adjusted. You could see eight lines straight away, though you could equally possibly see only four, perhaps with additional steps on them. It's also feasible that you might only see a rising stepped waveform, possibly with

SCOPE EXPANDER

base for a sweep speed of 50 to 100µs. Connect the unit's sync output to either the external sync input or the second signal input channel (if you have one), and switch the scope's sync switch for triggering on a positive-going signal from the selected channel. (Syncing via the channel connected to S1 will not produce the desired effect.) Connect the unit to a suitable clock and data source, for example to the parallel output socket of a computer. It is preferable at this time that the data source should produce random output codes.

Set the data source and its clock running. Switch S1 down, so that the input sync is

Part Two.
In which John Becker describes the testing and use of this scope trace multiplier, data store and logic analyser.

additional sub-steps on each step. Adjust the sync lock control on the scope until the traces become static. If necessary, then switch the time-base to a higher or lower setting until you clearly see eight traces. You may also need to switch the scope input amplifier to a different gain or attenuation setting, so that the traces better fill the screen.

Now you can adjust VR1 so that the data stored in memory is multiplexed out onto the screen traces. Slowly turn VR1 clockwise and you should see steps appear on some or all of the lines. It is assumed at this point that a fair mixture of logic 0 and logic 1 has been recorded in the block you are examining. If

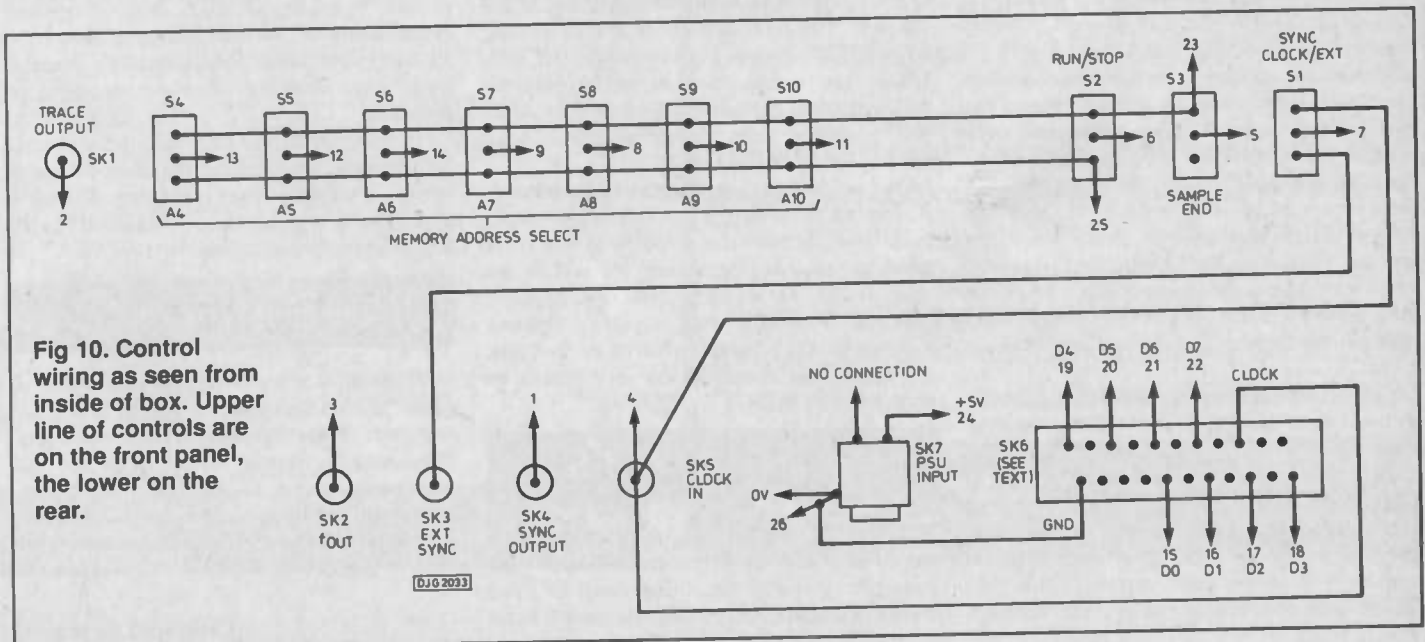

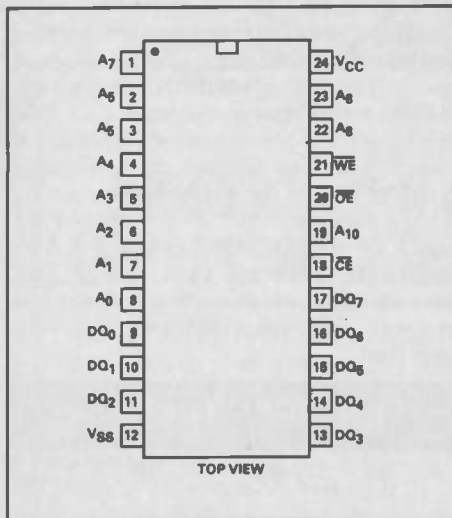

Fig 11. Pin outs of the unit's static random access memory (sram).

you don't see any change, the most likely reason, apart from a circuit malfunction, will be because your signal data source was placing zeros on all the lines. It's equally possible that your data source has been placing all logic 1s on the lines, in which case you will see all lines rise up as you turn VR1. If, as expected, a mixture of data has been recorded, increasing VR1 will increase the amplitude steps on each line. Continue turning VR1 until the steps are clearly visible yet do not encroach on the line above them. On my own scope the best step heights were about 200mV high. Photo 3 shows a shot of the scope screen displaying traces produced by the unit.

BYTES AND BITS

Once you've set VR1 satisfactorily, you can check that other memory data blocks hold different data. You do this by switching on any combination of S4-S10 to bring a different memory block onto the lines.

The maximum number of data bits that will normally be displayed on any one line is 16, as dictated by the size of each memory block. If it is obvious that fewer than 16 bit positions are on screen, then reduce the scope time-base setting until 16 bits are catered for. By slowing down the time-base speed even further you can display more than 16 bits per line, but after the 16th bit, the other bits will be a repetition of the first 16, as the unit will be recycling through the same block for another time. You may alternatively increase the time-base speed so that you can deliberately examine fewer bits, though these will always be the first bits in any memory block.

If you have a programmable data source it is possible to make further checks on the unit. Program the source to repeatedly send the binary codes for decimal numbers 0 to 255 in sequence out to the unit. Set all address switches up. Set S1 down, S3 up, and then take S1 down and then up. This primes the unit to wait for an input sequence. Now run the programmed source. As it cycles through

its 0-255 sequences, the unit will record them, finally switching back to replay mode at the end of the full cycle.

Now you can examine that the unit has recorded the binary digits correctly. The lower trace will contain the least significant bits and will thus show more steps. The line above will show half the number, the one above half of that, and so on. The top four lines should all be low since the code on display only represents decimal numbers 0-15, requiring only a 4-bit code. You will need to switch on some of the address switches to show a representation of the higher numbers. Do this and see what happens, checking your estimation of the binary number shown at each point on the screen against a binary to decimal chart.

It is conceivable that the unit may have ignored the first zero, recording only from the first 1. This will be due to the unit's reaction time to the starting sync pulse. The result will be that you see the binary equivalents of 1 to 16 on screen.

TESTING OPTION

The device I used to program a check data sequence was my good-old Commodore 3032 Pet. (It's still without its own screen, but I've designed an interface for it so that it now feeds via a uhf modulator into a portable tv. More on that in the PE Tele-Scope article!) This is the program I used:

```
100 DRT=59459: OUT=59471: AT=59468:
DN=205: UP=237: POKE OUT,255
```

```
110 FOR A=0 TO 255: POKE OUT,A:
POKE AT,DN: POKE AT, UP: NEXT A:
GOTO110
```

DRT is the data direction register, which is set as an 8-bit output by poking it with 255. OUT is the output register into which data is written and from which the data is sent to the output port. AT is the ATN (attention) line register. This is used as the clock source for the unit. The ATN line is set low by poking AT with DN, and set high by poking AT with UP. If you intend using a similar program with your own computer, all the register codes will probably need changing (check your manual for the equivalents).

As written, the above routine increments A, poking the resulting number to the output port. You can poke the output with any other number you like, providing it's within the range 0-255. For example, you could poke it with the contents of the computer's memory location relating to the value of A. For this, the second statement in line 110 would be changed to POKE OUT, PEEK(A).

OTHER TRACES

If you have a scope with more than one trace, a dual or triple-trace scope for example, you can use the second or third traces simultaneously with the unit's octal

tracing. You will need to adjust the scope controls to make room for the additional traces, then you simply use the other probe or probes to monitor the additional lines you want to examine.

The scope must still be synchronised from the specified sync point in the unit, but the unit itself can be synchronised to any other point in the circuit you're examining. The required sync point is brought in to the sync input socket SK3. S1 should now be switched up to route the sync signal to IC9a.

BRILLIANCE

When the scope's additional channels are used in parallel with the unit you will notice that there is a difference in the apparent brightness of the additional channel traces. The unit's multiplexed signal will be less bright than the additional traces. This is because you are seeing the additional traces at their normal screen-crossing rate, whereas the multiplexed signal is in reality crossing the screen at only one eighth of this rate. Why only one eighth? Visualise what is actually happening to the trace. It crosses the screen in order to display the lowest line. It then jumps up by the height of the first step, and again it crosses. It does this repeatedly until all eight steps and transitions have been made. In the meantime the trace from the second true channel has crossed the same point on the screen eight times. You're dealing with an illusion for the multiplexed lines, but that illusion results in the eye seeing each line for less time than that of the true additional channel.

A further point to be aware of is that by switching on the scope's additional channels you may, depending on the nature of your scope, be changing the rate at which all the traces occur. If your scope generates its second trace by alternating between the two input channels, then every second step of the multiplexed trace may disappear. Adjustment of the scope's time-base rate should compensate for the scope's internal switching, allowing all eight channels to reappear.

If using a second true channel you can, for example, monitor the unit's clock signal while observing the multiplexed traces. This clock signal is also available for triggering external equipment, via SK2.

LOGIC ANALYSING

From all that has been said you will have gathered that unit enables you to check the sequence of events on eight different digital lines simultaneously. These lines do not necessarily need to be 8-bit data lines associated with, for example, a computer output or similar 8-bit data source. They

Continued on page 43

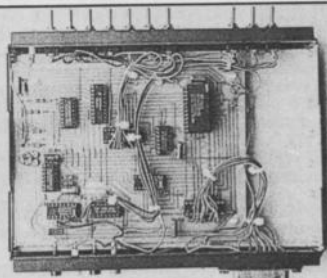

ALL KITS INCLUDE PCBs

THIS MONTH'S GREAT PE FEATURE!

TELE-SCOPE (PE SEP-OCT 90) Interface for turning any tv into an oscilloscope. Plugs into aerial socket. It can save you hundreds of pounds!
Comps & case :SET 303 £89.95

FREQUENCY COUNTER-GEN (PE SEP 89)
Great value & highly versatile test gear. 2 freq gens produce analogue (over 20kHz) & digital (over 2MHz) waveforms. Lcd counter displays freq of int & ext sigs to 4MHz. Components & case (excl lcd) : SET 296 £33.50 (LCD counter module PCIM300 available from Cirkit).

MONO-STEREO ECHO STATION (PE OCT 89)
Lengthy echo, reverb, multi-tracking, phasing, flanging, chorus & vibrato effects with mono & stereo signals. Echo to 25ms on std unit. Echo to 166ms & multiple range choice on long unit. Infinite reverb on both units. Extended delay version : SET 294L £65.00. Standard delay version : SET 294S £33.50.

PHONOSONICS
LEADING SUPPLIERS OF KITS FOR PE PROJECTS SINCE 1972

MESSAGE MAKER (PE MAY-JUN 90)
Give sophistication to your displays: put moving messages of your choosing on a semi-intelligent alphanumeric lcd screen. Computer or eeprom operation. Logic comps & case (excl eeprom) : KIT 299.1 £32.50. LCD module extra : £29.50

MORSE DECODER (PE JUL 90)
Semi-intelligent module decodes morse from radio, cassette, etc, displaying on alphanumeric lcd screen. No prior knowledge of morse reqd, but unit will help you learn it! Logic components & case : KIT 300.1 £30.95. Programmed eeprom extra : £15.00. LCD module extra : £29.50.

EEPROM PROGRAMMERS (PE JAN-FEB 90)
Eeproms are re-programmable without the need for erasing with uv light. Here's a choice of programmers! 16-digit keypad data entry unit : KIT 297.1 £67.50. Hex-switch data entry unit : KIT 297.2 £29.95.

RADIO CLOCK (PE MAR-MAY 90)
Decodes Rugby signals & displays time and calendar data on led screen. Needs no batteries, resetting or winding up - you need never be late again! Receiver logic comps : KIT 298.1 £13.00. Decoding logic comps : KIT 298.2 £36.50. Programmed eeprom extra : £15.00. LED module extra : £11.00.

DUAL BEAM SCOPE (PE NOV 88-JAN 89)
Ideal for the enterprising constructor - a diy twin-trace 1MHz scope with all the usual features for variable time-base, sync & input on both channels. Set of circuit components : KIT 290 £57.50. CRT, transformer & case excl - catalyst states purchase sources.

SCOPE EXPANDER (PE AUG-SEP 90)
Multiply your test viewing - give your scope 8 digital traces on 1 chan. Also acts as logic analyser. Comps & case : SET 302 £45.95

VOICE SCRAMBLER (PE JUN 88)
Retain your communications privacy with 32 switch-selectable coded chans. Transmitted signal incomprehensible to unauthorised listeners without equivalent unit. Unit doubles as coder and decoder, switchable. Comps & case : SET 287 £49.50.

GEIGER COUNTER (PE AUG 86)
High level radiation detector with speaker, meter and computer output. Upgraded version of orig PE project as demonstrated 3 times on BBC tv. Battery operated, very portable. Components & case : SET 264 £65.50.

CATALIST

Many more PE projects in our Catalist! Send medium sized SAE for your copy and with all enquiries. (Overseas send £1.00 to cover postage.)

ORDERING

Add 15% VAT on all UK orders. Add P&P - kits over £50 add £3.50, others add £2.50. Photocopies £1.00 per monthly part plus 50p post. Insurance 50p per £50. (Overseas: double UK P&P & ins rates.) Payment CWO, CHQ, PO, ACCESS, VISA. Order by post or via answering machine.

PHONOSONICS, DEPT PE99,
8 FINUCANE DRIVE, ORPINGTON,
KENT, BR5 4ED.
Tel: 0689 37821 (answering machine).

Interak 1
BUILD YOUR OWN COMPUTER

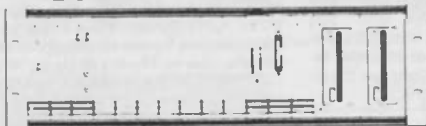

INTERAK can be commenced with the minimum of outlay. Bare boards from £10.95. Buy or borrow or steal the components or buy from us - all parts available separately. No special or custom chips (ie PALs, ULAs, ASICs etc) used - no secrets.

Go as fast or as slowly as your funds and enthusiasm permit.

Made for those who must know what goes inside. Full circuit diagrams and descriptions are provided. And honestly, can you really use a computer effectively if you don't know what's inside and nobody will tell you?

Solid engineering construction - something to be proud of. 19" 3U rack mounting plug-in circuit boards and modular construction keeps obsolescence at bay.

Flourishing Independent Users Group and newsletter. Hundreds of programs on disk at little or no cost from the Users Group.

Program in machine code (Assembler), Basic, C, Forth, etc. Database, Word Processing, Scientific applications.

Cassette tape operation or disk (up to 4 drives, 1 Megabyte 3.5" available from us, but you can add 3", 5.25", 8" if you want). Disk operating system CP/M Plus.

64K RAM, Z80 based at present with potential for expansion to a 16 Megabytes address space and Zilog's latest Z80280 in the future.

Needs no specialised knowledge to construct and we will happily get you out of a jam if you get into one.

Availability of personal and individual after sales service, impossible to obtain from large companies who are only after your money.

Security of supply - from Greenbank Electronics, established in 1970.

Greenbank

For more details write or phone us:
Greenbank Electronics, Dept E09P, 460 New Chester Road,
Rock Ferry, Birkenhead, Merseyside, L42 2AE. Tel: 051-645 3391

BTEC Electronic & Computer
Engineering

For a practical course blending computing, electronics and engineering relevant to industry:

Join us in **September 1990** for the **BTEC National Diploma or Certificate. Two Years, full or part-time**

This course is highly relevant to industry and emphasises practical experience for further details please contact:
The Faculty of Science & Technology
School of Scientific Technology,
North East Surrey College of Technology
Reigate Road, Ewell, Epsom Surrey KT17 3DS
Telephone: 081-394 3096/98/99

nescot
North East Surrey College of Technology

ONE POUND PACKS

All packs are £1 each. Note the figure on the extreme left of the pack ref number and the next figure is the quantity of items in the pack, finally a short description.

- BD2 5 13A spurs provide a fused outlet to a ring main where devices such as a clock must not be switched.
- BD9 2 6V 1A mains transformers upright mounted with fixing damps.
- BD11 1 6.5-in speaker cabinet ideal for extensions, takes our speaker. Ref. BD137.
- BD13 12 30 watt reed switches, it's surprising what you can make with these - burglar alarms, secret switches, relay, etc., etc.
- BD22 2 25 watt loudspeaker two unit crossovers.
- BD30 2 Nicad constant current chargers adapt to charge almost any nicad battery.
- BD32 2 Humidity switches, as the air becomes damper the membrane stretches and operates a microswitch.
- BD42 5 13A rocker switch three tags so on/off, or change over with centre off.
- BD45 1 24hr time switch, ex-Electricity Board, automatically adjust for lengthening and shortening day, original cost £40 each.
- BD49 5 Neon valves, with series resistor, these make good night lights.
- BD56 1 Mini uniselector, one use is for an electric jigsaw puzzle, we give circuit diagram for this. One pulse into motor, moves switch through one pole.
- BD67 1 Suck or blow operated pressure switch, or it can be operated by any low pressure variation such as water level in water tanks.
- BD103A 1 6V 750mA power supply, nicely cased with mains input and 6V output leads.
- BD120 2 Stripper boards, each contains a 400V 2A bridge rectifier and 14 other diodes and rectifiers as well as dozens of condensers, etc.
- BD128 10 Very fine drills for pcb boards etc. Normal cost about 80p each.
- BD132 2 Plastic boxes approx 3in cube with square hole through top so ideal for interrupted beam switch.
- BD134 10 Motors for model aeroplanes, spin to start so needs no switch.
- BD139 6 Microphone inserts - magnetic 400 ohm also act as speakers.
- BD148 4 Reed relay kits, you get 16 reed switches and 4 coil sets with notes on making c/o relays and other gadgets.
- BD149 6 Safety cover for 13A sockets - prevent those inquisitive little fingers getting nasty shocks.
- BD180 6 Neon indicators in panel mounting holders with lens.
- BD193 6 5 amp 3 pin flush mounting sockets make a low cost disco panel.
- BD199 1 Mains solenoid, very powerful, has 1in pull or could push if modified.
- BD201 8 Keyboard switches - made for computers but have many other applications.
- BD211 1 Electric clock, mains operated, put this in a box and you need never be late.
- BD221 5 12V alarms, make a noise about as loud as a car horn. Slightly soiled but OK.
- BD252 1 Panostat, controls output of boiling ring from simmer up boil.
- BD259 50 Leads with push-on 1/4in tags - a must for hook-ups - mains connections etc.
- BD263 2 Oblong push switches for bell or chimes, these can mains up to 5 amps so could be foot switch if fitted into pattress.
- BD268 1 Mini 1 watt amp for record player. Will also change speed of record player motor.
- BD305 1 Tubular dynamic mic with optional table rest.
- BD653 2 Miniature driver transformers. Ref. LT44, 20k to 1k centre tapped.
- BD548 2 3.5V relays each with 2 pairs changeover contacts.
- BD667 2 4.7 uF non-polarised block capacitors, pcb mounting.

There are over 1,000 items in our One Pound Pack List. If you want a complete copy please request this when ordering.

GIGER COUNTER KIT includes tube, PCB and all components to make a 9V counter £34. Ref 39p1

PERSONAL STEREOs Again customer returns but complete and with stereo head phones a bargain at only £3.00 each. Our ref 3P83.

MAINS OPERATED MICROWAVE CONTROL PANEL with Touch switches. This unit has a 4 digit display with a built in clock and 2 relay outputs - one for power and 1 for pulsed power level. Could be used for all sorts of timer control applications. Only £6.00. Our ref 6P18.

EQUIPMENT WALL MOUNT Multiangle for speakers etc. £3 each ref 3P72.

SUB-MIN TOGGLE SWITCH Body size 8mm x 4mm x 7mm SBDT with chrome dolly fixing nuts. 3 for £1. Order ref BD649.

COPPER CLAD PANEL for making PCB. Size approx 12in long x 8.5in wide. Double-sided on fibreglass middle which is quite thick (about 1/16in) so this would support quite heavy components and could even form a chassis to hold a mains transformer, etc. Price £1 each. Our ref BD683.

MAINS FANS Brand new, snail type. Approx. 6" x 4" approx. 70W only £4.00. Ref. 4P58.

REAL POWER AMPLIFIER for your car, it has 150 watts output. Frequency response 20Hz to 20KHz and signal to noise ratio better than 60dB. Has built in short circuit protection and adjustable input level to suit your existing car stereo, so needs no pre-amp. Works into speakers ref. 30P7 described below. A real bargain at only £57.50. Order ref: 57P1.

POWERFUL IONISER

Generates approx. 10 times more IONS than the ET1 and similar circuits. Will refresh your home, office, workroom etc. Makes you feel better and work harder - a complete mains operated kit, case included £18.00. Our ref 18P2.

REAL POWER CAR SPEAKERS. Stereo pair output 100W each. 4-Ohm impedance and consisting of 6.5in woofer, 2in mid range and 1in tweeter. Ideal to work with the amplifier described above. Price per pair £30.00.

Order ref: 30P7.

VIDEO TAPES These are three hour tapes of superior quality, made under licence from the famous JVC Company. Offered at only £3 each. Our ref 3P63. Or 5 for £11. Our ref 11P3. Or for the really big user 10 for £20. Our ref 20P20.



ELECTRONIC SPACESHIP. Sound and impact controlled, responds to claps and shouts and reverses when it hits anything. Kits with really detailed instructions. Ideal present for budding young electrician. A youngster should be able to assemble but you may have to help with the soldering of the components on the pcb. Complete kit £10. Our ref. 10P81.

COMPOSITE VIDEO KITS. These convert composite video into separate H sync, Vsync and video. Price £8.00. Our ref 8P39.

12" HIGH RESOLUTION MONITOR Amber screen, beautifully cased for free standing, needs only a 12V 1.5 amp supply. TTL input, sep syncs required. Brand new in makers' cartons. Price: £22.00. Order ref: 22P2.

BUSH RADIO MIDI SPEAKERS Stereo pair. BASS reflex system, using a full range 4in driver of 4 ohms impedance. Mounted in very nicely made black fronted walnut finish cabinets. Cabinet size approx 8.5in wide, 14in high and 3.5in deep. Fitted with a good length of speaker flex and terminating with a normal audio plug. Price £5 the pair. Our ref 5P141.

3.5in FLOPPY DRIVES We still have two models in stock: Single sided, 80 track, by Chicon. This is in the manufacturers metal case with leads and IDC connectors. Price £40, reference 40P1. Also a double sided, 80 track, by NEC. This is uncased. Price £60, reference 60P2. Both are brand new. Insured delivery £3 on each or both.

YUASHA LEAD ACID BATTERIES 6V 10A. Superb Value at only £12.00 REF 12P24 or 2 for £20.00 ref 20P29. Also some 12V 1.9AH £7.00 REF 7P19.

VERY POWERFUL 12 VOLT MOTORS. 1/3rd Horsepower. Made to drive the Sinclair CS electric car but adaptable to power a go-kart, a mower, a rail car, model railway, etc. Brand new. Price £20.00. Our ref. 20P22.

SINCLAIR CS WHEELS. Set of 4 wheels with inner tubes and tyres. 2 13" dia. front wheels and 2 6" dia. rear wheels. Brand new £6 each 13" Ref 6P10 16" Ref 16P11.

ELECTRONIC SPEED CONTROL KIT Suitable for controlling our powerful 12v motors. Price £17.00. Ref. 17P3 (heatsink required).

ORGAN MASTER Is a three octave musical keyboard. It is a beautifully made, has full size (piano size) keys, has gold plated contacts and is complete with ribbon cable and edge connector. Can be used with many computers, request information sheet. Brand new, only £15 plus £3 postage. Our ref 15P15.

HIGH RESOLUTION MONITOR. 9in black and white, used Philips tube M24306W. Made up in a lacquered frame and has open sides. Made for use with OPD computer but suitable for most others. Brand new. £20.00 plus £5 post. Our ref 20P26.

PHILIPS LASER

This is helium-neon and has a power rating of 2mW. Completely safe as long as you do not look directly into the beam when eye damage could result. Brand new, full spec. £35.00. Mains operated power supply for this tube gives 8kv striking and 1.25kv at 5mA running. Complete kit with case £15.

12 VOLT BRUSHLESS FAN. Japanese made. The popular square shape (4.5in x 4.5in x 1.75in). The electronically run fans not only consume very little current but also they do not cause interference as the brush type motors do. Ideal for cooling computers, etc., or for a caravan. £8 each. Our ref 8P26.

MINI MONO AMP on p.c.b. size 4in x 2in (app.)

Fitted Volume control and a hole for a tone control should you require it. The amplifier has three transistors and we estimate the output to be 3W rms. More technical data will be included with amp.

Brand new, perfect condition, offered at the very low price of £1.15 each, or 13 for £12.00.

JOYSTICKS for BBC, Atari, Dragon Commodore, etc. All £5.00 each. All brand new, state which required.

SUB-MIN PUSH SWITCHES Not much bigger than a plastic transistor but double pole PCB mounting. 3 for £1.00. Our ref BD688.

AA CELLS Probably the most popular of the rechargeable NICAD types. 4 for £4.00. Our ref. 4P44.

20 WATT 4 OHM SPEAKER With built in tweeter. Really well made unit which has the power and the quality for hifi 6.5in dia. Price £5.00. Our ref. 5P155 or 10 for £40.00 ref. 40P7.

MINI RADIO MODULE Only 2in square with ferrite aerial and solid dia. tuner with own knob. It is superb and operates from a PP3 battery and would drive a crystal head phone. Price £1.00. Our ref. BD716.

BULGIN MAINS PLUG AND SOCKET The old and faithful 3 pin with screw terminals. The plug is panel mounted and the socket is cable mounted. 2 pairs for £1.00 or 4 plugs or 4 sockets for £1.00. Our ref. BD715, BD715P, or BD715S.

MOSFETS FOR POWER AMPLIFIERS AND HIGH CURRENT DEVICES 140v 100watt pair made by Hitachi. Also available in H pack Ref 25J99 and 25K343 £4.00 a pair. Ref 4P51.

TIME AND TEMPERATURE LCD MODULE A 12 hour clock a Celsius and Fahrenheit thermometer a too hot alarm and a too cold alarm. Approx 50x20mm with 12.7mm digits. Requires 1AA battery and a few switches. Comes with full data and diagram. Price £9.00. Our ref. 9P5.

REMOTE TEMPERATURE PROBE FOR ABOVE. £3.00. Our ref. 3P60. **25 WATT STEREO AMPLIFIER IC STK043.** With the addition of a handful of components you can build a 25 watt stereo amplifier. Supplied with a circuit diagram. £4.00 REF 4P69.

600 WATT AIR OR LIQUID MAINS HEATER Small coil heater made for heating air or liquids. Will not corrode, lasts for years. Coil size 3in x 2in mounted on a metal plate for easy fixing. 4in dia. Price £3.00. Ref. 3P78 or 4 for £10.00. Our ref. 10P76.

EX-EQUIPMENT SWITCHED MODE POWER SUPPLIES Various makes and specs but generally +5, +12V ideal bench supply. Only £8.00. Our ref 8P36.

ACORN DATA RECORDER Made for the Electron or BBC computer but suitable for others. Includes mains adaptor, leads and book. £12.00. Ref. 12P15.

PTFE COATED SILVER PLATED CABLE 19 strands of .45mm copper will carry up to 30A and is virtually indestructible. Available in red or black. Regular price is over £120 per reel. Our price only £20.00 for 100m reel. Ref. 20P21 or 1 of each for £35.00. Ref 35P2. Makes absolutely superb speaker cable!

NEW PIR SENSORS Infra red movement sensors will switch up to 1000w mains, UK made, 12 month manufacturers warranty, 15-20m range with a 0-10min timer, adjustable wall bracket. Only £25.00. Ref 25P16.

MAINS FANS 80mm square silent mains fans ideal for equipment cooling where space is at a premium. They give quite a good draught and use about 12 watts. £9.00 ref 9P10.

10 MEMORY PUSHBUTTON TELEPHONES These are customer returns and sold as spares. They are complete and may need slight attention. Price £6.00 Ref 6P16 or 2 for £10.00 Ref 10P77 BT approved.

MINIATURE DOT MATRIX PRINTERS. These are 24 column 5v and similar to the one sold by Radio Spares for £46.00. You can have one for £10 ref 10P92.

MYLAR CONE SPEAKERS. These 85mm square 35ohm 2 watt speakers are ideal for outside use as they are virtually waterproof. £1.00 each ref BD903.

SPECTRUM SOUND BOX Add sound to your Spectrum with this device. Just plug in. Complete with speaker, volume control and nicely boxed. A snip at only £4.00. Our ref. 4P53.

BBC JOYSTICK INTERFACE Converts a BBC joystick port to an Atari type port. Price £2.00. Our ref. 2P261.

TELEPHONE EXTENSION LEAD 5m phone extension lead with plug on one end, socket on the other. White. Price £3.00. Our ref. 3P70 or 10 leads for only £19.00 Ref. 19P2.

LCD DISPLAY 4.5in digits supplied with connection data £3.00. Ref. 3P77 or 5 for £10. Ref. 10P78.

CROSS OVER NETWORK 8 Ohm 3 way for tweeter midrange and woofer nicely cased with connections marked. Only £2.00. Our ref. 2P255 or 10 for £15.00. Our ref. 15P32.

REVERSING LIGHT ALARM Fits to car reversing light and sounds when reversing. Only £2.00. Our ref. 2P248.

BASE STATION MICROPHONE Top quality uni-directional electret condenser mic 600r impedance sensitivity 16-18KHz - 68db built in chime complete with mic stand bracket. £15.00. Ref. 15P28.

MICROPHONE STAND Very heavy chromed mic stand, magnetic base 4in high. £3.00 if ordered with above mic. Our ref. 3P80.

SOLAR POWERED NICAD CHARGER 4 Nicad AA battery charger. Charges 4 batteries in 8 hours. Price £6.00. Our ref. 6P3.

MAINS SOLDERING IRON Price £3.00. Our ref. 3P65. **SOLDERING IRON STAND** Price £3.00. Our ref. 3P66. **SHARP PLOTTER PRINTER** New 4 colour printer originally intended for Sharp computers but may be adaptable for other machines. Complete with pens, paper etc. Price £16.00. Our ref. 16P3.

CAR IONIZER KIT Improve the air in your car, clears smoke and helps prevent fatigue. Case req. Price £12.00. Our ref. 12P8.

NEW FM BUG KIT New design with PCB embedded coil 9v operation. Priced at £5.00. Our ref. 5P158.

NEW PANEL METERS 50uA movement with three different scales that are brought into view with a lever. Price only £3.00. Ref. 3P81.

STROBE LIGHTS Fit a standard edison screw light fitting 240V 40min. flash rate available in yellow, green. Complete with socket. Price £10 each. Ref. 10P80 (state colour required).

WHITE EXTENSION CABLE WITH A DIFFERENCE It is flat on one side making it easy to fix and look tidy. 4 core, suitable for alarms, phones etc. Our price only £5.00 for 50m reel. Ref. 5P153.

METAL PROJECT BOX Ideal for battery charger, power supply etc. Sprayed grey size 8in x 4in x 4.5in. Louvred for ventilation. Price £3.00. Ref. 3P75.

TV SOUND DECODER Nicely cased, mains powered with 8 channels. Will drive a small speaker directly or could be fed into HIFI system etc. £12.00 each. Ref 12P22.

2KV 500WATT MAINS TRANSFORMERS Suitable for high voltage experiments or as a spare for a microwave oven etc. £10.00 Ref 10P93.

STC SWITCHED MODE POWER SUPPLY 220V or 110V operation giving 5v at 2A +24 at 0.25A +12 at 0.15A and +90v at 1A. £12.00 each. Ref 12P27.

YUASHA SEALED LEAD ACID BATTERIES 6V 10AH ONLY £9.00 each or 2 for £15.00 Ref 15P37.

PC STYLE CASES 18" x 18" x 6" Complete with fan abd grill illuminated power switch and IEC filtered power input plug. Priced at only £15.00 Ref 15P38.

PC POWER SUPPLIES Brand new with built-in fan and power switch on the back +5 +5 +12 -12 150 Watt made by Aztec £25.00 each Ref 25P18. **BOSCHERT SWITCHED MODE POWER SUPPLIES** +5 at 15A +12 at 2A +24 at 2A 220V or 110V input. Brand new and guaranteed. Retail price is £180! Ours £20. Ref 20P30.

BULL ELECTRICAL

Dept. PE 250 PORTLAND ROAD, HOVE, BRIGHTON, SUSSEX BN3 5QT.

MAIL ORDER TERMS: Cash, PO or cheque with order. Please add £2.50 service charge. Monthly account orders accepted from schools and public companies. Access and B/Card orders accepted - minimum £5. Phone (0273) 203500. Fax: (0273) 23077.

POPULAR ITEMS - MANY NEW THIS MONTH

1990 CATALOGUE NOW AVAILABLE PLEASE SEND £" X 9" SAE FOR FREE COPY



Electronic thermometers with led numeric displays are common nowadays and may be purchased ready-made for far less than the cost of the individual components. They usually display the temperature to a tenth of a degree - but are they *really* that precise? This circuit has a bargraph display instead, which indicates temperature to the nearest degree on the Celsius scale. Many people prefer such a display since, at a glance, it gives a clearer visual impression of temperature than is given by a series of digits. The illuminated display of the instrument is a distinctive and attractive addition to any desk-top. The display is reminiscent of the conventional liquid-in-glass thermometer. A row of 20 leds indicates temperature within one of two 20-degree ranges, 0°C to 19°C and 20°C to 39°C. This fully covers the range likely to be encountered in the average living-room or workshop. It is possible to adapt the design to cover other ranges between 40°C and 100°C, as will be explained later.

The similarity of the display to an ordinary thermometer is enhanced by the 'bulb' at one end of the bar. But the bulb is not the part that senses temperature. It is an led, of the type that can be made to glow with different colours. It glows green when the display is switched to the lower range and it glows red when it is switched to the higher range. In this way it acts as a range indicator.

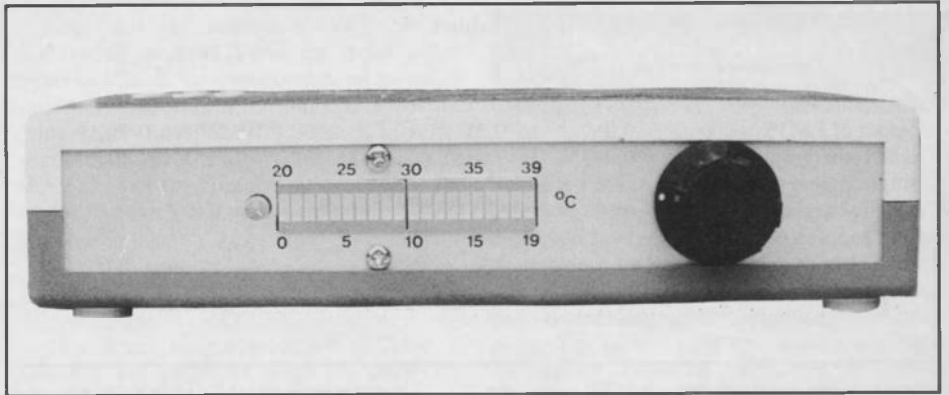

One of the advantages of the LM35, as compared with sensors of other types such as thermistors and diodes, is that it draws very little current. Its operating current is only 56µA, and thus very little power is dissipated in the device. This means that there is virtually no self-heating effect to upset the accuracy of measurements.

Fig.1 shows that the output from the sensor is passed to an adder. This is an operational amplifier which adds various voltages to the output voltage to match it to the input required by the bargraph display. Since the range of inputs to the bargraph ics is larger than the output range of the sensor, we also need a multiplying amplifier. Table 1 sets out the calculations that these two amplifiers have to perform. Use the table as a model for your

own calculations, should you wish to adapt the design to other temperature ranges.

Consider the low range first. While the temperature rises from 0°C to 20°C, the output of the sensor rises from 0V to 0.2V. The sensor and amplifiers are operating on a split supply, +4.5V, and the values in the table are with reference to the 0V rail. On the other hand, the bargraph ics must receive the increasing input needed to light up the leds one by one. The bargraph ics accept an input in the range 0.015V to 1.5V below the positive supply (ie 7.5V with a 9V supply). For convenience, we have settled on an input range of 0.015V to 7.015V, so that an increase of 1°C is equivalent to 0.35V increase in input. These figures are shown in the third

DESK THERMOMETER

HOW IT WORKS

The main sections of the circuit are shown in the system diagram (Fig.1). The temperature sensor is an LM35 precision Celsius temperature sensor. This ic, which operates on any supply voltage in the range 4V to 20V, has an output which is linearly proportional to the Celsius temperature. When temperature is 0°C the output is 0V. As temperature increases, the output rises by 10mV per degree. Thus, as 25°C, for example, the output is 0.25V. This easily understood relationship between temperature and output voltage makes calibration of the circuit very straightforward. It also makes it easy to adapt the circuit to other ranges of temperature.

The LM35 is manufactured in two versions, LM35CZ and LM35DZ. The CZ version covers the range -40°C to 110°C. To measure temperatures below zero, it is powered by a split supply and gives negative output voltages at such temperatures. In this circuit we use the cheaper DZ version, which has a smaller range, 0°C to 100°C. This can be powered with a single supply but this makes it less precise at temperatures below 2°C. We use it with a split supply to obtain full precision (+0.9°C) over the entire range. Precision is better than this (+0.6°C) at typical room temperatures.

Whatever the weather, you'll warm to Owen Bishop's easy-to-calibrate led display.

line of Table 1. However, when we are working out what the amplifiers have to do, we must relate the bargraph input voltages to the amplifier split supply voltages. We must subtract 4.5V from bargraph inputs to show what the amplifier outputs must be. This has been done in the fourth line of the table.

We now have to find out what the amplifiers must do to convert a voltage ranging from 0V to 0.2V into a voltage ranging from -4.485V to +2.515V. The conversion is made by adding a certain fixed voltage and then multiplying. The multiplying factor is the easiest to work out. The voltage range from the sensor is 0.2V, and the

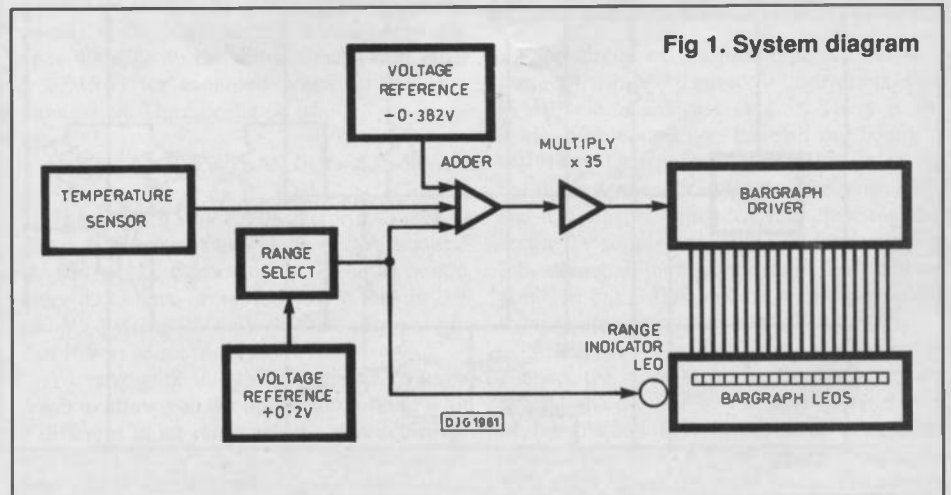

Fig 1. System diagram

Range	Table 1	
	1) Low	2) High
Temperatures	0°C to 20°C	20°C to 40°C
Output of LM35	0.0V to 0.2V	0.2V to 0.4V
Input to bargraph (single supply)	0.015V to 7.015V	0.015V to 7.015V
Input to bargraph (split supply)	-4.485V to +2.515V	-4.485V to +2.515V
Conversion - add	-0.128	-0.328
multiply	X35	X35

bargraph in put range is 7V, so the multiplying factor is $7/0.2 = 35$.

Now we can work out the voltage to be added. Call this v . The conversion equation can be written for the low end of the scale (0°C):

$$35(0 + v) = -4.485$$

Solving this equation gives: $v = -0.128$. You can check that the equation for the upper end of the scale (20°C) gives the same value for v .

On Range 2, the output from the sensor varies from 0.2V to 0.4V, a range of 0.2V, as before. The bargraph input is to be the same as on Range 1. The multiplying factor is 35, as before. At the low end of range 2 (20°C) we find:

$$35(0.2 + v) = -4.485$$

Solving this equation gives:

$$v = -0.328$$

Thus we have to add -0.128V on Range 1, and -0.328V on range 2. There are various ways of doing this. In this circuit, we add -0.328V on both ranges, and switch in an extra voltage of +0.2V when the instrument is on range 1. A rotary switch is used to connect the +0.2V when on range 1, and to control the colour displayed by the range indicator led.

CIRCUIT DETAILS

The 9V power supply (see later) is split by a potential divider (R1,R2) to give +4.5V, 0V and -4.5V rails (Fig.2). The sensor (IC1) is powered from the 0V and +4.5V rail, but has a pull-down resistor (R3) connected to the -4.5V rail to give a 0V output at 0°C. These connections can also be used with the LM35CZ, if you are building a thermometer to operate at temperatures below zero. The amplifiers (IC2, IC3) are powered from the +4.5V and -4.5V rails.

The opamps are cmos types, specially designed to operate on low-voltage supplies.

IC2 is connected as a summing amplifier, with three inputs to the inverting input, each by way of a resistor (R4-R6). These and the feedback resistor (R7) all have the value 15k and, to reduce errors, should all be of 1% tolerance. The -0.328V input is provided by a band-gap reference voltage device (D23). This produces a reference voltage of -1.26V (typically) at the point indicated. A variable potential divider (VR1) taps off 0.328V which is fed through R6 to the amplifier. Another voltage reference (D2) produces a reference voltage of +1.26V (typically) at the point indicated. A variable potential divider (VR1) taps off -0.328V which is fed through R6 to the amplifier. Another voltage reference (D2) produces a reference voltage of +1.26V, which is tapped by the potential divider VR2 to give +0.2V. When Sib is in the range 1 position, this voltage is fed to the amplifier through R15. Since a summing amplifier of this kind produces the *inverse* of the sum of its inputs, the output of IC2 on Range 1 is:

$$(V_{out} - 0.328 + 0.2) = -(V_{out} - 0.128)$$

On Range 2 the output is:

$$(V_{out} - 0.328)$$

Note that the setting of VR1 can be slightly adjusted to allow for input offset errors in IC2. IC3 is connected as an inverting amplifier with gain of 35. Since R10 has the value 15k, we adjust VR3 so that, in series with R11, it gives a total feedback resistance of 525k. Since the polarity of the output is the inverse of the input, the output of IC3 on Range 1 is:

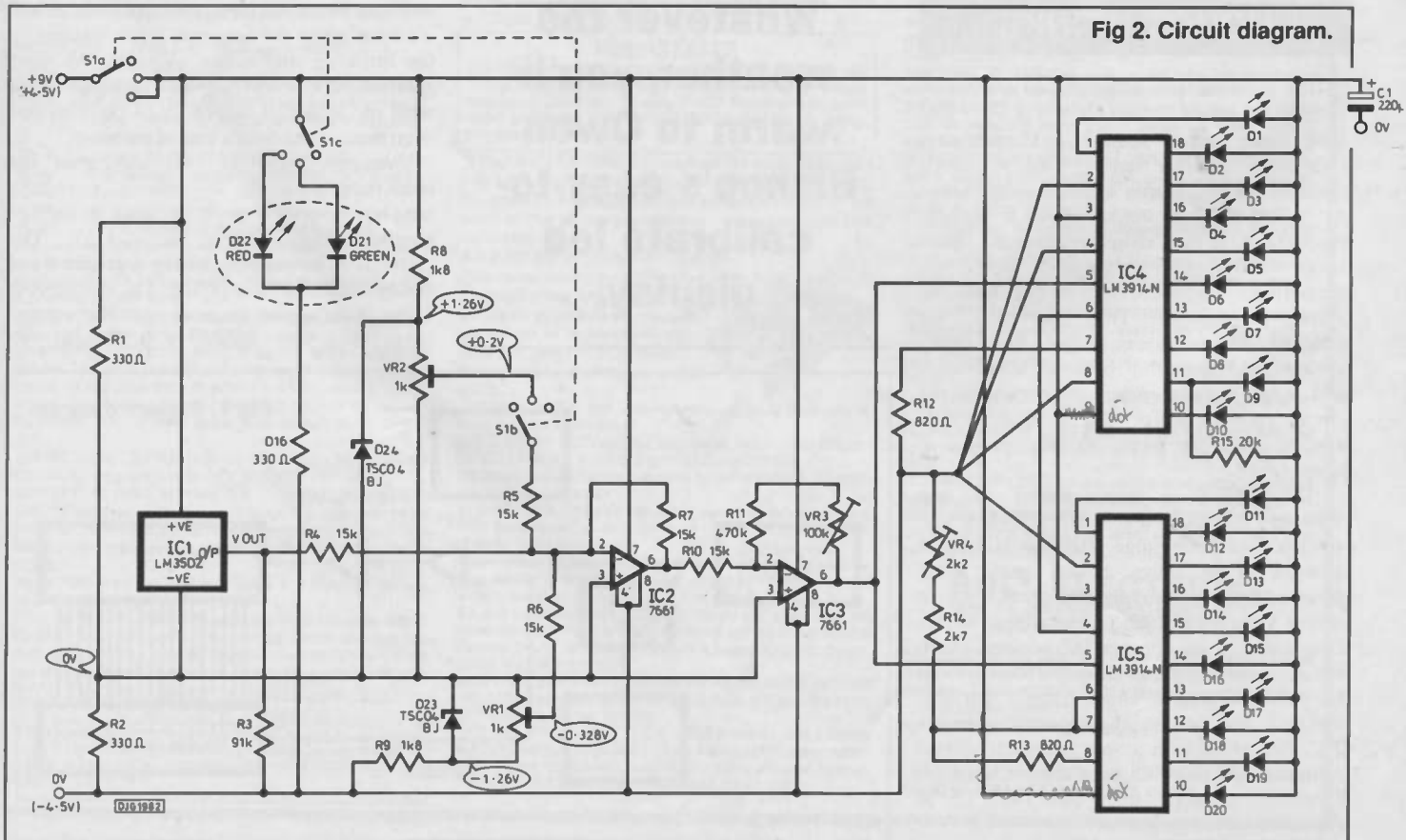

Fig 2. Circuit diagram.



$$(V_{out} - 0.328 + 0.2) = -(V_{out} - 0.128)$$

On Range 2 the output is:

$$(V_{out} - 0.328)$$

COMPONENTS

RESISTORS

R1, R2	330, 1% (2 off)
R3	91k
R4-R7, R10	15k, 1% (5 off)
R8, R9	1k8 (2 off)
R11	470k
R12, R13	820 (2 off)
R14	2k7
R15	20k
R16	330

(Carbon 0.25W, 5% tolerance, unless otherwise specified)

POTENTIOMETERS

VR1, VR2	1k horizontal sub-miniature presets
VR3	100k horizontal sub-miniature presets
VR4	2k2 horizontal sub-miniature presets

CAPACITORS

C1	220n tantalum
----	---------------

SEMICONDUCTORS

D1-D20	10-bar dil led array (green or red) (2 off)
D21/D22	tri-colour led
D23, D24	TSC04BJ band-gap voltage reference. 1.26V (2 off)
IC1	LM35DZ precision Celsius temperature sensor
IC2, IC3	ICL7611 cmos operational amplifier (2 off)
IC4, IC5	LM3914N bargraph driver (2 off)

MISCELLANEOUS

S1	4-pole, 3-way rotary switch
Knob for S1	
Strip-board	(a) 12 strips by 67 holes, (b) 26 strips by 11 holes, (c) small scrap for mounting sensor
1mm terminal pins	single-sided (27 off) and double-sided (4 off) transistor socket
8-way dil sockets	(2 off)
18-way dil sockets	(2 off)
20-way dil sockets	(2 off)
15cm 20-way ribbon cable	
Instrument case	180mm x 120mm x 40mm
Bolts for mounting display panel	
(Optional) 9V 400mA regulated mains power supply unit	and 3.5mm mono jack socket.

Note that the setting of VR1 can be slightly adjusted to allow for input offset errors in IC2. IC3 is connected as an inverting amplifier with gain of 35. Since R10 has the value 15k, we adjust VR3 so that, in series with R11, it gives a total feedback resistance of 525k. Since the polarity of the output is the inverse of the input, the output of IC3 on Range 1 is:

$$(35 \times -(V_{out} - 0.128)) = 35(V_{out} - 0.128)$$

This is the output specified in Table 1. Similarly, the output on range 2 is $35(V_{out} - 0.328)$.

The two bargraph ics (IC4, IC5) are connected in cascade. Each receives its input from IC3 at pin 5. The ics contain a series of comparators which compare the input voltage against voltages found along an internal chain of resistors. We have to arrange that the voltage at one end of the chain is -4.5V and is +2.515V at the other. The low end of the chain in IC4 (pin 4) is connected to the -4.5V rail. The high end of the chain in IC4 (pin 6) is connected to the low end of the chain in IC5 (pin 4). The high end of the chain in IC5 (pin 6) is connected to a stabilised reference voltage (pin 7). This is set to give a reference voltage of +2.515V. To work out how to obtain this, it is simpler to return to considering the power supply to the bargraph ics as being 0V and 9V. We need to set the reference to 7.015V. The reference is set by setting the ratio between two resistors, R13 and the combined resistances of R14 and VR4. For simplicity we refer to R14+VR4 as Rc. The reference voltage obtained is given by:

$$V_{REF} = 1.25(1 + R_c/R13)$$

or:

$$R_c/R13 = V_{REF}/1.25 - 1$$

For a reference voltage 7.015V we get:

$$R_c/R13 = 7.015/1.25 - 1 = 4.6 \text{ (approx)}$$

Now we have to take into account the fact that the value of R13 also determines the current through the display diodes. In other words, it determines the brightness of the display. If the power supply is able to provide up to 400mA, we can allow about 15mA ($I_{eD} = 0.015A$) for each led when all leds are illuminated. The calculation is:

$$R13 = 12.5/I_{eD} = 12.5/0.015 = 833 \text{ ohms}$$

This gives a suitable value for R13 as 820 ohms. A resistor of this value is also required for IC4 (R12). Consequently, Rc must be 4.6 times 833 ohms, or 3833 ohms. If R14 is 2k7 and VR4 is 2k2, this allows the voltage at pin 7 of IC5 to be set to 7.015V.

We have gone into this calculation in some detail to allow you the option of working with a different input range and to adjust display brightness according to the capabilities of your power supply.

POWER SUPPLY OPTIONS

This circuit is designed to be powered by a stabilised mains psu, with an output of 9V at up to 400mA. Such units are cheaply available ready-built for plugging into a 13-amp mains socket. The advantage of having the psu external to the instrument case, is that this avoids heating the interior of the case, producing falsely high temperature readings. If you are intending to mount the sensor externally, this advantage does not apply, but there are still the advantages of low cost and avoiding the hazards of building the parts of the circuit which have live mains voltages. Mains powered psus often have a switchable output range. Make sure that the one you buy has a 9V output and that it is stabilised (the cheapest psus are not stabilised and are useless for this application). Make sure too that it is capable of delivering up to 400mA, without a drop in output voltage. Some psus are not protected against overloading and simply burn out if required to supply more current than they are intended to do.

Alternatively, the thermometer may be powered by a 9V battery, either a PP3, or a six cells in a 9V battery box. A battery may be housed inside the instrument case as it does not produce appreciable heat. The difficulty with a battery is that the bar leds consume large amounts of current. The battery soon becomes partly discharged and the accuracy of readings is badly affected. The brightness of the display can be reduced to save power, as described above, but power requirements are still large enough to run down the battery fairly quickly. A much better way of saving power is to change the display to 'dot mode'. Instead of the whole bar, only one led (the top end of the bar) is illuminated. To change to dot mode, omit the connections between the 9V supply rail and pin 9 of IC4 and IC5. This puts the ics into dot mode. Then connect pin 9 of IC4 to pin 1 of IC5 (which is also connected to D11 cathode). This ensures that D10 is turned off when the input voltage exceeds the maximum for IC4.

CONSTRUCTION

The circuit of the prototype is built on a piece of strip-board cut to fit into vertical slots in the instrument case (Fig.3). There is one solder-blob connection beneath the board, at G10/H10. One point to remember in laying out the board is that several of the pins of IC4 and IC5 must be grounded very close together on the 0V supply rail. This is indicated in Fig. 2 by taking all these connections to a common point. In Fig. 3 this point is the portion of the lowest copper strip between L39 and L45.

A length of 20-way ribbon cable is used to connect the main board to the display board (Figs.4 and 5). The +9V supply to the anodes of the display leds is taken by a separate flexible lead from a point close to where the +9V supply joins the main board. The current

Fig 3. Stripboard layout and reverse side.

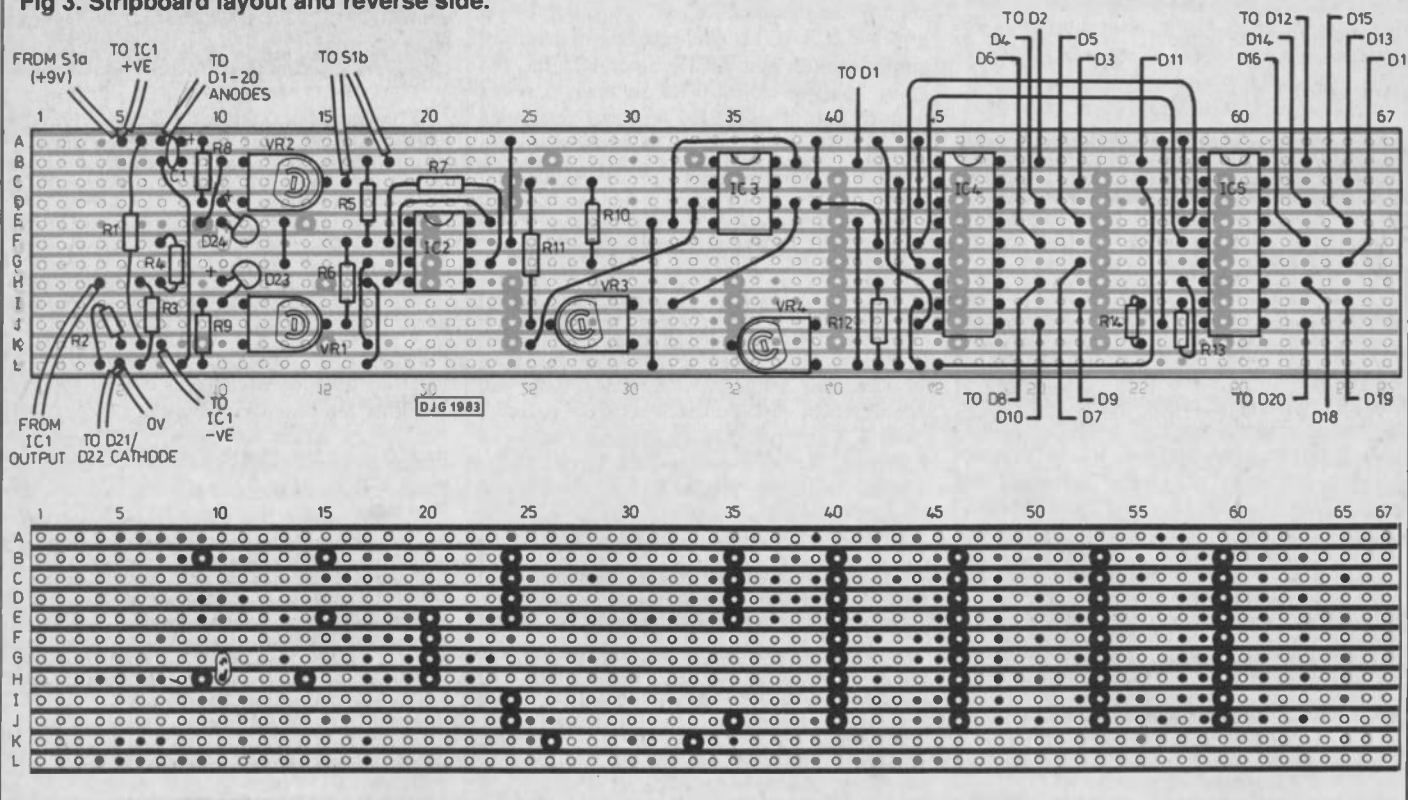

to the leds may be several hundred milliamps and the capacitor C1 is required to damp out oscillations as leds are switched on or off.

The leds are purchased as dil arrays, each of 10 leds. The arrays plug into two 20-way dil sockets on the display board. The strips between opposite pins of the sockets are cut beneath the board. So that the board can be mounted to the front panel, it is preferable for the wiring to the board to be inserted on the strip side of the board. The 20k resistor (R15) is required only for a dot mode display, but it does not affect the display in bar mode. Use double-sided terminal pins on this board so that other leads can be soldered to the rear of the board.

S1 acts as an on/off and range selecting switch. The figure shows a 4-pole 3-way switch, but a 3-pole 4-way switch could be used instead.

The sensor can be mounted inside the

enclosure or externally. In the prototype it is mounted at the rear of the enclosure. A transistor socket is soldered to a small piece of strip-board and this is held in position by a short length of pcb adhesive-backed guide. You could bolt the board in position, or use Bluetack or a 'sticky fixer', instead. The bottom rear and top of the case is bored with ventilation holes in the region of the sensor. It is a good idea to insulate the part of the enclosure in which the sensor is situated by walling it off with expanded polystyrene. This prevents heat from the circuit (and particularly the ribbon cable) from affecting the sensor. This is important if the instrument is to run continuously, rather than to be switched on only when a temperature reading is required. Mounting the sensor externally eliminates heating problems. To mount the sensor externally, run the leads from the main board to a stereo jack socket mounted on the rear panel.

SETTING UP

You need a room thermometer, preferably an accurate mercury-filled type, graduated in degrees Celsius. Measure the room temperature and then switch on the instrument to a range that includes this temperature. The 'bulb' led glows green or red, depending on the range selected.

Connect a voltmeter between the 0V supply (the pin at L5 on the main board) and pin 6 of IC5. Adjust VR4 until the reading is 7.015V (or as close to it as your voltmeter can indicate). Connect the voltmeter to the 0V rail of the sensor and opamps (the junction of R1 and R2). Check that Vout from the sensor is in the region 0V to 0.4V, depending on room temperature. Since you know what the room temperature is, you will be able to work out what Vout should be (see earlier).

Adjust VR1 so that the voltage at its wiper

Fig 4. Display board.

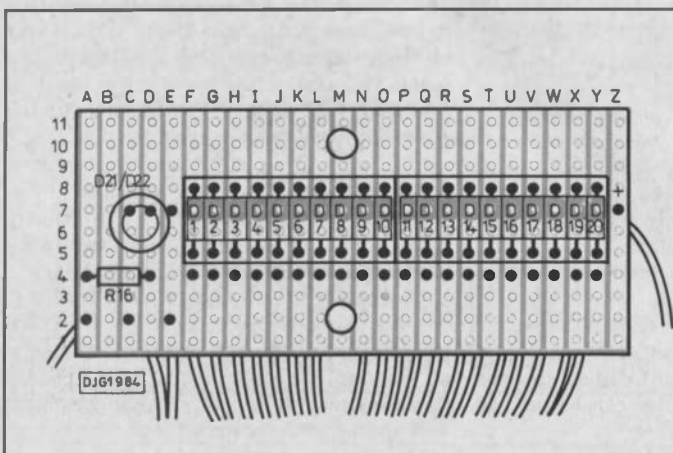
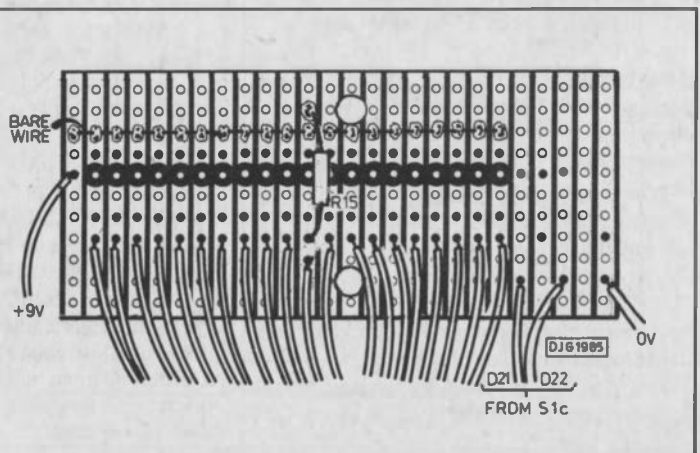

Fig 5. Display board reverse side.





is -0.328V (or as close to it as your meter can indicate). Adjust VR2 to +0.2V. Check and note the output of IC2, at pin 6. This is -(Vout - 0.328). Connect the voltmeter to the output of IC3, at pin 6. Adjust VR3 until the output is -35 times the output of IC2.

The number of leds illuminated on the display depends on the room temperature. Grip the sensor gently between thumb and fore-finger. The bars extends in length. Release your grip and the bar contracts as the sensor cools down. If the turning on of the leads is slow, so that the 'top' of the bar consists of two or three half-on leds, you are having problems with oscillations in the circuit. Try increasing the value of C1, and check that all power line connections are securely made. If you are using a battery, check that its voltage is at full strength. Put the thermometer in a room in which the temperature is a little below 20°C Switch to range 1. Now grip the sensor between your thumb and finger to warm it. By gripping or releasing the sensor you can make the temperature increase or decrease in the region of 20°C. Switch between ranges and, if necessary, adjust VR2 until there is a smooth transition between ranges.

This completes the initial calibration. Try putting the thermometer in situations at different temperatures and compare its readings with your standard room thermometer. Leave both in a new situation for five minutes or more to give them time to reach the new temperature. Do not expose

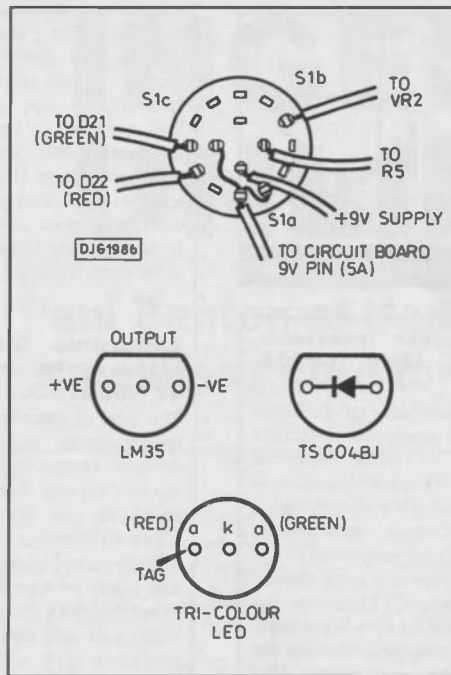

Fig 6. Switch wiring and pin-out details.

either the room thermometer or the sensor to direct sunlight as this will result in spurious readings. You may find that it is necessary to make slight adjustments to the settings to take account of inaccuracies in the original settings or small errors inherent in the amplifier circuits.

SCOPE EXPANDER

Continued from page 36

had the unit at the time I was designing the Rugby Clock I would most certainly have used it to monitor several different aspects of that circuit at the same time, storing and holding them for examination. This would have saved me the trouble of writing several diagnostic machine code programs so that I could use the Pet as a monitor. I have also used the unit extensively in analysing the behaviour of another circuit I am working on.

You will have also spotted that the project I'm describing now can be used as a logic analyser as well as an event monitor. You have, of course, just seen how it can be used in this way when I was referring above to checking the scope screen data states against the binary to decimal chart. The unit can't perform the binary to decimal conversion for you, as a computer would, but for simple analysis you can use it in conjunction with a b-d chart, with good effect.

This is most certainly a versatile and worthwhile piece of test equipment which I am pleased to have introduced to my workshop. I'm sure you'll be pleased to do likewise.

PE

PE

WE HAVE THE WIDEST CHOICE OF USED OSCILLOSCOPES IN THE COUNTRY

H P 174A Dual Trace 100MHz Delay Sweep	£550
TELECOMPONENT DB3 Dual Trace 50MHz Delay Sweep	£300
GOULD O5300A Dual Trace 40MHz Dual Sweep TV Trg	£200
TELECOMPONENT DP55 Dual Trace 50MHz Delay Sweep	£275
COBSON CDD150 Dual Trace 35MHz Delay Sweep	£180
GOULD OS1100 Dual Trace 30MHz TV Trg	£210
S E LABS SM111 Dual Trace 100MHz	£130
TRUD C3156A Dual Trace 20MHz	£250
H P 122A Dual Trace 150MHz TV Trg	£175
GOULD O2555 Dual Trace 150MHz TV Trg	£180
PHILIPS PM323 Dual Beam 100MHz TV Trg	£150
GOULD O2550B Dual Trace 150MHz TV Trg	£160

THIS IS JUST A SAMPLE - MANY OTHERS AVAILABLE

TEXTROMX 2215 DUAL TRACE 80MHz SWEEP DELAY WITH MANUAL, PROBES, FRONT COVER, POUCH ONLY £500

MARCONI TF2015 AM/FM 0.1-100MHz 2 Ch Gen with TF2171	£450
MARCONI TF2015 without Synthesiser TF2171	£300
MARCONI TF2016 AM/FM 100K-120MHz 2 Ch Gen with TF2173	£400
MARCONI TF2016 without Synthesiser TF2303 from DYNAMAR 1525 AM/FM 0.1 - 100MHz 2 Ch Gen	£250
H P 6200 Signal Generator 1-110 MHz	£420
H P 618C Signal Generator 0.1-7.6 GHz	£420
H P 618B Signal Generator 1.8-4.2GHz	£420
FERRAGRAM HRTS Recorder Test Set	£275
WOLKE Woo & Futur Meter ME108	£180
LEAFER LMY108A Top CHANNEL Multimeter 50MHz 500KHz 100 uV 300V	£100
FEEDBACK FG01 2 Ch Gen 0.001Hz-1MHz Sine/Sq/Tri	£150
MARCONI Automatic Character Meter TF2337A 400Hz or Measures down to 0.01%	£100
LE VELL OSCILLATORS TG152/TG200 series from MARCONI TF2700 UNIVERSAL LCR BRIDGE. Battery from	£ 95

HAMEG LOGIC SYSTEM

HM8001 8 Man Trns with HM8032 Sine Wave Generator 20KHz - 200MHz	£150
HM8030 2 Function Generator 0.1 - 1MHz Sine/Sq/Tri/Saw and HM8011 Digital Multimeter 4.5 digit	£275
SADETA MC321 COLOUR BAR GENERATOR RF Bands 13MHz & Video, Sound Carrier Unmod (P&P £7)	£125
SADETA COLOUR BAR GENERATOR PAL MCV 01 & PATTERNS Packet Set, Rechargeable Belt Computer with Battery Charger Unmod (P&P £6)	£50
Large Colour Bar Generator KG1 8 test Patterns (P&P £4) only	£40
ADBEAR CROSS-HATCH GENERATOR Type CM6030-DB Crown and Gray Scale/Bar Generator Manual or BATTERY - Unmod (P&P £12 (P&P £3))	£100
TRIO RF SIGNAL GENERATOR Type SG462 1000Hz-30MHz Unmod (P&P £7)	ONLY £50
ADVANCE S0820 AM 150KHz-220MHz	£45 (P&P £7)
MICROTEXTX CLUB MONITOR 14" COLOUR	£80

TELEPHONES - YES! REAL DIAL TYPE TELEPHONES

that don't slide around the desk. Type No. 745 supplied with standard BT plug (Used)..... Only £5 each. Quantity discount

Used equipment - with 30 days guarantee. Manuals supplied, if possible. This is a VERY SMALL SAMPLE OF STOCK. SAE or Telephone for LISTS. Please check availability before ordering. CARRIAGE all units £16. VAT to be added to total of Goods & Carriage.

STEWART OF READING
110 WYKEHAM ROAD, READING RG6 1PL, BERKS RG6 1PL
Tel: 0734 68041 Fax: 0734 351696
Callers welcome 9 am - 5.30 pm (until 8 pm Thursday)

TEKTRONIX OSCILLOSCOPE 2236 Dual Trace 100MHz Delay Sweep £750
PHILIPS OSCILLOSCOPE PM3217 Dual Trace 50MHz Delay Sweep £500
GOULD O5300 Oscilloscope Dual Trace 20MHz £250
GOULD 1421 Digital Storage Dual Trace 20MHz £750
THANDAR PL3200MD 0-30V 2A Tracer Quad Mode Digital Meter £200
FEEDBACK FSG 606 Sweep Function Generator 0.01Hz - 1MHz (P&P £7) £200
SOLAARTRON 7045 Multimeter 44 digit LED 30 ranges Auto/Manual (P&P £7) £125
LOGIC PROBE Type 3300A TTL/CMOS (P&P £3) £10
FARNELL Oscillator LF M3 10Hz-10MHz Sine/Square £200
RACAL 8015 Freq Counter 10Hz-520MHz (Crystal Chan) £150
MARCONI 8000 Series Universal Counter Ten ans. Jern £150
MARCONI ATTENUATORS TP2162 DC-1MHz 200 ohm to 0.111ohm (P&P £7) £35
HATHFIELD ATTENUATORS 50 ohm DC-250MHz 0-100dB/600 ohm DC-1MHz (New Price £135) (P&P £4) ONLY £50

AVO MULTIMETERS (P&P 10 all

Avco 8c, 8c and Ministry Versions. With Batteries & Leads..... From £30	
TEST LEADS for Avco 8c, Red & Black with 2 croc Clips & 2 leads..... (P&P £3) £5	
Black EVER READY Case for Avco. Un-used..... (P&P £3) £15	
BATTERIES 15Vbatts..... £3 each, 10 for £25 (P&P extra)	
AVO TRANSISTOR ANALYSER M42 C7446 suitcase style. With Batteries & operating instructions..... ONLY £25 (P&P £7)	
MARCONI AF Power Meter TF 883A 20KHz-350Hz, 20mV - 10W With Manual..... ONLY £25 (P&P £7)	
MARCONI RF Power Meter TF 1152A/1 DC-500MHz 0.5 - 25W, 50 ohm With Manual..... ONLY £30 (P&P £7)	

NEW EQUIPMENT

HAMEG OSCILLOSCOPE HM1005 Triple Trace 100MHz Delay Timebase	£750
HAMEG OSCILLOSCOPE HM 604 DUAL TRACE 60MHz Delay Sweep	£575
HAMEG OSCILLOSCOPE HM 205 4 Dual Trace 20MHz Compartment Tester	£314
HAMEG OSCILLOSCOPE HM205 2 Dual Trace 20MHz Digital Storage	£527
All other models available & all oscilloscopes supplied with 2 probes	
BLACK STAR EQUIPMENT (P&P all units £5)	
APOLLO 10 - 100MHz Counter Time or Ratio/Period/Time interval etc.	£222
APOLLO 100 - 100MHz (AS) (as above with more functions)	£285
METEOR 100 FREQUENCY COUNTER 100MHz	£ 90
METEOR 600 FREQUENCY COUNTER 600MHz	£126
METEOR 1000 FREQUENCY COUNTER 10Hz	£170
JUPITER 500 FUNCTION GENERATOR 0.1Hz-500KHz, Sine/Sq/Tri	£110
ORION COLOUR BAR GENERATOR P&P/Manual	£200
All other Black Star Equipment available.	
HUNG CHANG QM 7030 31/2 digit, Hand held 20 ranges including 10amp AC/DC 0.1% Acc. (P&P £4)	£30.50
As above QM 6010 0.25% Acc	£33.50
Carrying Cases for above.....	£ 3
OSCILLOSCOPE PROBES Statcheiba x1, x10. (P&P £3)	£11

New from Edward Arnold

DIGITAL CIRCUITS
J R Nowicki/L J Adam

A fundamental guide to the world of computers, data communications and control circuits. The larger number of worked design examples can, in most cases, be implemented directly on a breadboard system, together with unworked exercises to test the readers design skills.
Published March 1990 320 pages £12.95 net paperback
ISBN 0 7131 3641 3

Z80 MACHINE CODE INTERFACING
D B Harland

Assuming no previous knowledge, this text leads the reader through the principles of programming in machine code, using exercises which can be used on Z80 microprocessors and can be readily adopted for use on other 8-bit micros.
Published May 1990 160 pages £8.95 net ISBN 0 7131 3581 6

ELECTRONICS
Practical Applications and Design

C Morris
Published October 1989 160 pages £8.95 net paperback
ISBN 0 340 50427 7

COMPUTER INTERFACING
Connection to the Real World

M D Cripps
Published August 1989 240 pages £11.95 net paperback
ISBN 0 7131 3588 3

Edward Arnold
Hodder & Stoughton Publishers
Mill Road, Dunton Green, Sevenoaks, Kent TN13 2YA
Tel: 0732 450111 Fax: 0732 461321



Your Ed looks at some of the new books recently received.

Build Your Own Universal Computer Interface. Bruce Chubb. Tab Books. £19.05. ISBN 0-8306-3122-4.

In over 300 pages, this American book provides an in-depth coverage of how you can build a universal computer interface system (UCIS) that is readily attachable to many different computers. Among the computers for which detailed information is given are the IBM PC, XT, AT, System/2 and their compatibles, various models of TRS80, Apple II, VIC20, Commodores 64 and 128, and Heathkit/Trionix H8. The BBC family of machines is not mentioned so far as I can see. (Have the Americans been denied access to one of the UK's more popular computers?) However, the author advises that "If you have a computer that I haven't covered, please don't give up on the UCIS. Study the reference manual for your computer and compare its bus description to examples I've covered." The book claims to detail the complete technology of universal computer interfacing from theory to step-by-step assembly instructions. Both hardware and software are covered. You are shown how you can use interfacing circuits with your computer to control just about anything, from home security systems and robotics to model train layouts and all types of industrial control systems. This is a book full of useful information that should spark off your imagination to make better use of your own computer.

Troubleshooting and Repairing VCRs. Gordon McComb. Tab Books. £17.20. ISBN 0-8306-2960-2.

In the USA, from where this book originates, it is estimated that 50% of all households have at least one video cassette recorder (vcr). For Americans, troubleshooting, repairing and maintaining vcrs is both a lucrative business for repair technicians and an expensive proposition for consumers. If you are of the opinion that a similar situation applies in the UK, then you could well find benefit from this book. Gordon McComb is a regular author for Tab and he is also a certified electronics technician who owns and operates a successful vcr and electronics business. This book thus comes straight from the horse's mouth, and it is designed specifically for the consumer. It offers complete schematics and step-by-step details on general upkeep and repair of home vcrs, from the simple cleaning and lubricating of parts, to troubleshooting psu and logic circuitry problems. The author explains, in a non-technical manner, the care and repair of all types of vcr, though you should not expect that your own specific model will be mentioned by name. He introduces the vcr, giving you the basics of operation and installation, and explaining general preventative maintenance procedures. He describes troubleshooting techniques and procedures for the vcr itself, as well as citing problems not caused by the vcr, such as bad tapes, improper hook-up, malfunctioning tv and others. Flowcharts are provided for vcr malfunctions, including decks that don't turn on, won't play tapes, start/stop problems, and many other situations. If your vcr is out of guarantee and misbehaving, this book could put you on track to inexpensively solving the problem.

Advanced BASIC Scientific Subroutines. B.V.Cordingly and D.J.Chamund. Macmillan. £9.50. ISBN 0-333-43569-9.

I am not sure that this book will necessarily help you directly with your electronics problems, though some of the routines given may help solve a particularly troublesome logic problem. The book is really aimed at those who are more involved with computing, but I know that many of you are deeply involved in both disciplines. Contained within the book is a valuable selection of program subroutines in structured Basic. It will be of immediate practical use for the solution of a wide range of mathematical and statistical problems. The subroutines are written in a highly portable version of standard Basic and are suitable for use with IBM PCs and compatible

machines. They cover generation of random numbers, probability, density and distribution functions, general statistics, analysis of variance, linear regression, matrix operations, interpolation, numerical analysis, calculus, solution of equations, and complex numbers. If you are involved in these areas the Basic routines presented will be invaluable and remove the need to write and debug your own programs. Even if your machine is not an IBM PC compatible, the routines will need only very slight modification (if any) to use them with your own computer. A diskette, containing all the programs included in the book for use on an IBM PC is also available from the publishers. Currently the disk is priced at £22 plus vat.

Electronic Display Devices. Edited by Shoichi Matsumoto. John Wiley and Sons. £39.95. ISBN 0-471-92218-8.

The first chapter sets out basic knowledge regarding the history of development, principles and construction of electronic display devices, comparing their performance and characteristics. The other seven chapters discuss particular display devices, in the areas of: principles of operation and systems; materials and physical properties; structure and manufacturing processes; drive methods and circuitry; display characteristics and performance; applications and uses; problems and outlook. To facilitate understanding, in all chapters many drawings, tables and photographs are provided, as are references and bibliographies at the end of each chapter. This is a specialist book and is best suited to those who have an advanced interest in electronic display devices. The editor is part of the Toshiba Corporation and the book is a translation from the original Japanese text.

Practical Digital Control. A.M. Zikic. Ellis Horwood Ltd. £57. ISBN 0-7458-0479-9.

Even if the price were to be lower, this book should still be regarded as a book for the advanced electronics designer. It is a two part study of computer controlled systems which is intended to familiarise the reader with digital control aspects, requirements and techniques. The book contains an introduction to the practical aspects of computer usage for control purposes, interfacing and implementation problems and limitations. It includes discrete direct and state space design techniques, with necessary mathematical introductions at appropriate points throughout. An extensive list of references where further theoretical or practical information can be found.

OP-AMP CIRCUITS MANUAL. R.M. Marston. Heinemann Newnes. £12.95. ISBN 0-434-91207-7.

The opamp is one of the most popular and versatile building blocks used in modern electronic circuit design, and will be a device close to the heart of practically all readers. The devices are available in three basic forms, the 'standard' (741, etc) type, the Norton (LM3900, etc), and the OTA (CA3080 and LM13600, etc). This book explains how each of these device families works and shows how to use them in practical applications. Over 300 circuits, diagrams and tables are presented. Although the manual is specifically aimed at the practical design engineer, technician and experimenter, it will be of equal interest to the electronics student and the amateur. It deals with its subject in an easy-to-read, down-to-earth, non-mathematical, and very comprehensive manner. I recommend this book to any reader who wants to gain more knowledge about opamps.

PUBLISHER'S ADDRESS

Ellis Horwood books are distributed by Halsted Press, a division of John Wiley and Sons.

Heinemann Professional Publishing, Halley Court, Jordon Hill, Oxford, OX2 8EJ. Tel : 0865 311366.

John Wiley and Sons, Baffins Lane, Chichester, West Sussex, PO19 1UD. Tel : 0243 779777.

Macmillan Education Ltd, Houndmills, Basingstoke, Hants, RG21 2XS. Tel : 0256 29242.

Tab Books are imported from the USA by John Wiley and Sons.

FLASHER ALARM

Anyone who drives a car must be quite aware of the problem of flashers! The flashers, that is, which indicate whether cars are turning right or left.

If the vehicle is turned sharply once the flashers have been set, the indicator will usually cancel. But, if the direction of the vehicle is relatively straight, the off switch may not trigger. Net result: the driver can become a flasher, often oblivious to the fact that the indicator continues to flash for several miles. This can be a potentially dangerous situation, and also an aggravating one to other road users.

In some cars the flasher unit ticks loudly enough to be heard by the driver, but not in all cars. My first idea to remedy the situation, for my own car was to instal a buzzing reminder in which the buzzer was attached to the feed wire of the lamps, using a couple of diodes. This was tried for two miles before the wires were pulled off and the buzzer stamped on! The sound of the buzzer 'doing its thing' on every flash was too much to take.

A happy medium was found by then using the circuit in Fig. 1, which uses a decade counter to trigger the buzzer once for every ten flashes. A simple solution that's kinder to the ears and other drivers!

PI:

INGENUITY UNLIMITED

Paul Benton of Hednesford, Staffs offers a painless cure for persistant flashers.

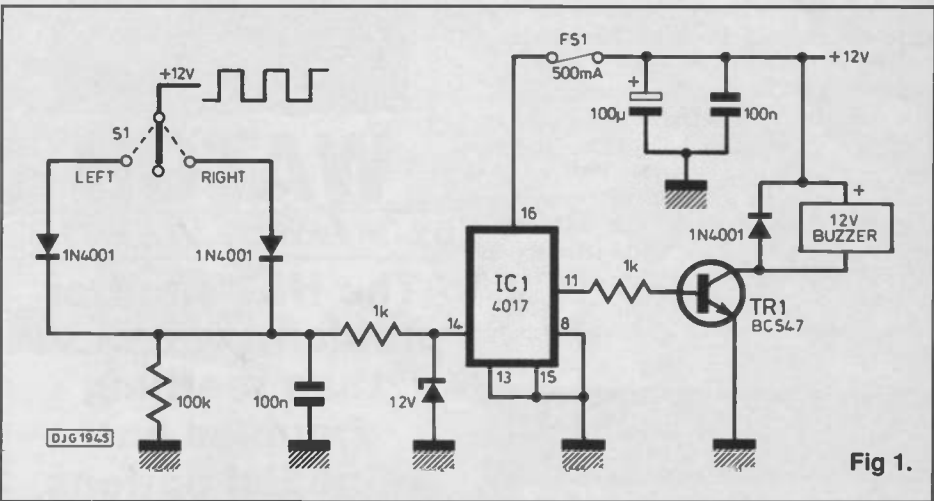

Fig 1.

EDISON continued from page 31

system to be the first and there were other people, like Swan in England, who were also working on developing better light bulbs. Then in 1879 Edison demonstrated the bulb he was to use. It had a carbon filament, and although it was nowhere near as reliable as today's bulbs it was a massive improvement on anything else which could be made at the time. Edison also demonstrated the system he was going to use. It would have the bulbs connected in parallel, so that if one bulb blew others could still operate. In addition to this they could also be turned on and off independently.

With the work progressing at tremendous rate the first system was soon opened. This happened on 4th September 1882 when Edison himself switched on the first commercial lighting system. It illuminated part of New York from a power station on Pearl Street in the centre of the city. This was a major milestone as it was the first time that electric lighting had been available in this way and it soon caught on.

SEMICONDUCTORS

Even so, work was still going on the prevent the blackening which occurred on

the inside of the bulbs. Several ideas were tried to overcome the problem. One of these was to place a second electrode into the bulb. When this was done Edison noticed that if he placed a battery between the two electrodes current would flow, but only in one direction. As he could see no application for this he did not investigate it any further. Even so he did demonstrate the effect (which he called the Edison Effect) to other people including Professor J.A. Flemming who was later to develop the diode valve for radio. Had it not been for Edison making the first observations of this effect then electronic technology would undoubtedly not be where it is today.

YEARS PASS

Edison's light company grew rapidly as the number of people using electric lights increased. He also found that the amount of work his inventors were having to do to keep pace with all this was increasing. As a result, Edison had to move his laboratories again, but this time it was to West Orange in New Jersey.

Not everything which Edison turned his hand to was successful. One major set back came when he had to unsuccessfully end a project for magnetically separating

iron ore from low grade deposits. He had spent colossal amounts of money on it and he had borrowed heavily from the banks. Consequently he lost control of his major company, The Edison General Electric Company. This was merged in 1892 with a number of other electrical companies to form the General Electric Company which is still one of the giants in America today. Although this was obviously a major blow for him he took it philosophically and continued with his other inventions.

LAST YEARS

As Edison grew older he carried on with his work and did not retire. If anything, his life became more varied as he took on different types of work. As one example, he became head of a naval research board during the first world war and this gave him the opportunity to work on weaponry. Apart from this he spent a lot of time trying to devise ways of obtaining rubber from garden weeds, as well as whole host of other ideas.

Edison died in 1931 at the grand age of 84. During his life he had invented more than any other person and was probably the only person ever to own an invention factory - which is what he called his laboratories.

PI:

On August 10 the Magellan space-probe is scheduled to enter a closed orbit round Venus. Magellan, launched in May last year, has one aim only: to complete and improve the radar maps of Venus' surface - which we can never see directly, because of the constant layer of dense cloud. Magellan is on course, and at present all the instruments seem to be in perfect working order. Radar mapping should go on for some years, at least for much longer than one 'Venus year' of 224.7 Earth-days.

Other probes have also been in the news. Giotto, which flew through Halley's Comet in 1986, passed by the Earth in July this year, and will be sent on to rendezvous with Comet Grigg-Skjellerup; much of its equipment is still functioning, though unfortunately the camera, which took those magnificent pictures of the Halley nucleus, is no longer operative. The Galileo probe is continuing its tortuous path to Jupiter, and approval has been given for the launch of the Cassini space-craft to Saturn in the mid-1990s.

The new office of the Royal Greenwich Observatory, at Cambridge, has been officially opened; the fate of the telescope at Herstmonceux-Castle is still undecided. Meanwhile, Dr Paul Nurdin, the famous astrophysicist, has been appointed Deputy Director of the RGO.

HUBBLE SPACE TELESCOPE

As most people know, there are serious problems with the Hubble Space Telescope - the great 94-inch reflector which was sent into a path round the Earth earlier this year, and which was expected to produce results far superior to anything possible with ground-based telescopes which have to look through the whole of the unsteady, obscuring atmosphere.

Preliminary "teething troubles" had been expected; for example, there were vibrations caused by the heating and cooling of the British-built solar panels, as the space-craft

SPACE

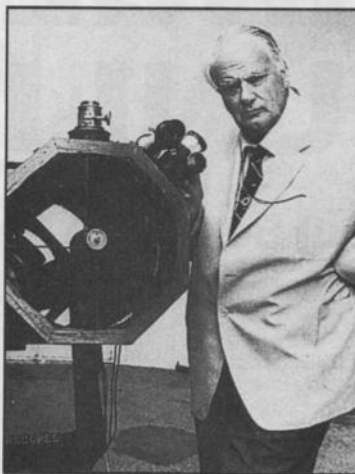

WATCH

BY DR PATRICK MOORE CBE

The HST's mirror problems are more than teething troubles but remedial options are being discussed

moved in and out of the sunlight, and radiation effects were also more pronounced than had been anticipated, periodically 'wiping' the memory of some of the on-board instruments. However, all this could be coped with. Much more serious is the revelation that there is something very wrong with the optical system. The trouble may lie with the main mirror or with the secondary; in any case, it prevents the images from being

brought to a sharp focus - and unless it can be remedied, the Hubble Telescope will not be able to do nearly as much as had been hoped.

What went wrong? There are several possibilities. One is that the main mirror has been wrongly constructed - and remember, a tiny error can have catastrophic results with regard to the telescope's performance. Another suggestion is that the tests with the primary and secondary mirrors acting together were not carried out with sufficient rigour. It is also possible that the trouble comes from the fact that the telescope ought to have been launched years ago, and has been 'lying around' waiting.

NONSENSE

Inevitably, the whole situation has been seized upon by those people who are always anxious to belittle the whole space programme. It has been claimed that "heads will roll"... that the telescope is "a white elephant" and that it is "the most expensive failure in scientific history". Frankly, this is nonsense. When working at the very limit of modern technology, it would be over-optimistic to expect perfection at the first attempt - and the Hubble telescope is something entirely new.

REMEDIES

We must look round for a remedy, and there are several alternatives. A "repair crew" could be sent up to see what can be done, though admittedly this does not seem to be practicable before about 1993. It may be possible to adapt the ground equipment to compensate for the errors in the mirrors. As a last resort, there is the idea of bringing the telescope back to the ground, repairing it and re-launching it. Which, if any, of these options will be taken up remains to be seen.

Yet even if nothing can be done to correct the fault, the telescope must not be dismissed as a failure. Optically, it should still at least equal any telescope on the surface of the Earth; more importantly, it can carry out

THE AUGUST SKY

August is not the best time of the year for stargazing, even though the nights are becoming longer. This month the Moon is full on August 6, and in a way this is a pity, as it will interfere with the start of the Perseid meteor shower. The Perseids can always be relied upon to provide a good display, and they reach their maximum on August 12, by which time the Moon will have vanished from the evening sky; but during the first week or so it is undeniable that they will be largely drowned by the brilliant moonlight. The Perseid shower ends around August 17, the Moon is new three days later.

Of the planets, Mercury and Jupiter are to all intents and purposes out of view, but Venus continues to be a splendid object in the east before dawn - though the phase is now well over 80 per cent, and no telescope will show anything definite upon the brilliant gibbous disk. Mars is also in the morning sky, south of the Pleiades or Seven Sisters in Taurus; it has become brighter than any star visible from Britain apart from Sirius, though it will

not be at its best until the latter part of November. Saturn is low in the south, in Sagittarius (the Archer), but by the end of August it will have disappeared by midnight.

There will be a partial eclipse of the Moon on August 6, but it will not be visible from Britain. In fact, from our islands there are no more eclipses this year.

The night sky is still dominated by the "Summer Triangle" of Vega, Deneb and Altair. The star-clouds in Sagittarius are visible in the south-west (remember that Saturn lies in this area, and is much brighter than any of the adjacent stars), while the Square of Pegasus is coming into view in the east. Altair, in Aquila, is distinguished by having a fainter star to either side of it. During August we may well see a naked-eye comet, Levy's, in this area; it may even have a detectable tail, and according to calculations the magnitude may rise to as much as three - but after the disappointment of Austin's Comet earlier this year, I hesitate to make any predictions!



researches in the ultra-violet region of the electromagnetic spectrum, which no ground-based telescope can do, at some wavelengths, because of the screening effects of the Earth's air. So it has been well worth building, despite the expense; even if it does not come up to all its expectations, it has shown the way for future instruments.

NASA has had a bad period: not only the Hubble fault, but also the temporary grounding of all the Shuttles. Let us hope that things can soon be put right, and that the space programme will be in full operation again before the end of the year.

Pictures show the HST's mirror and solar panels during manufacture. They were kindly supplied by NASA.

PE

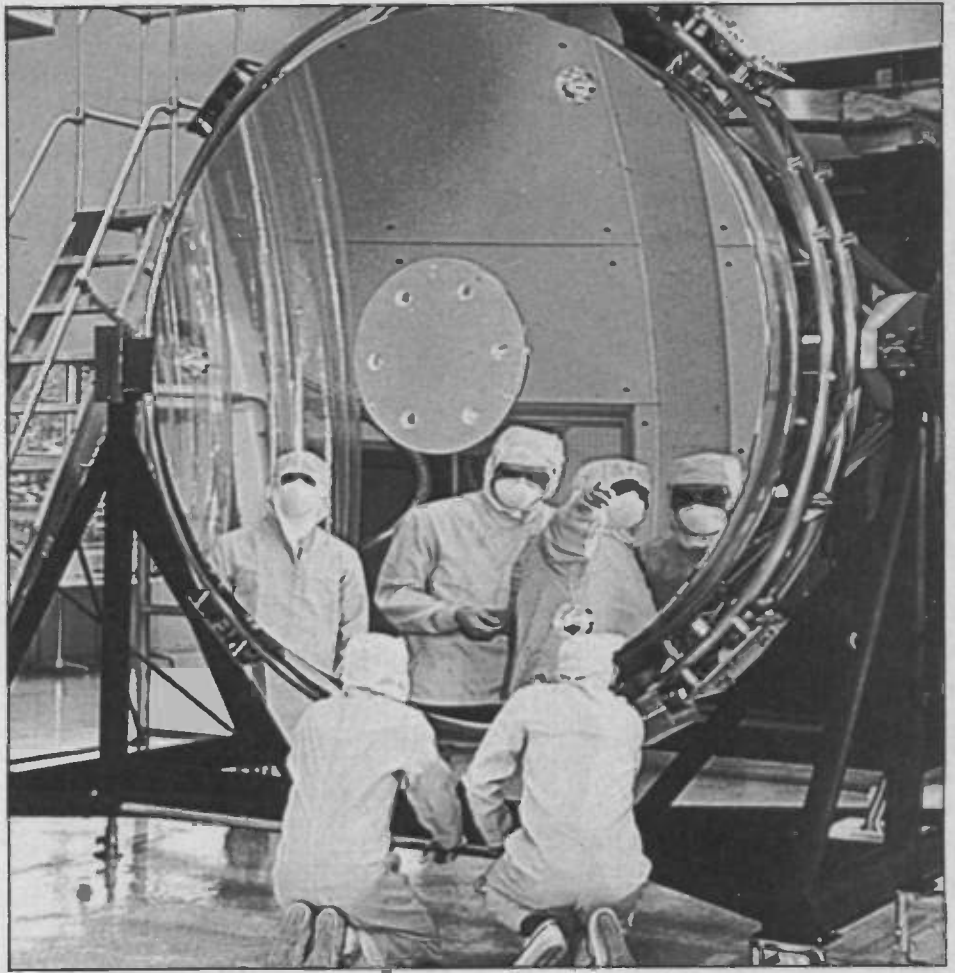
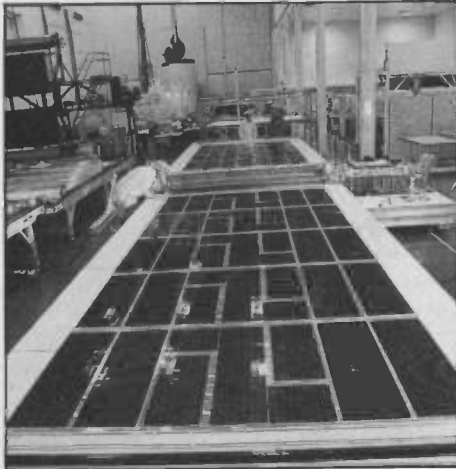

Astronomy Now

Britain's leading astronomical magazine

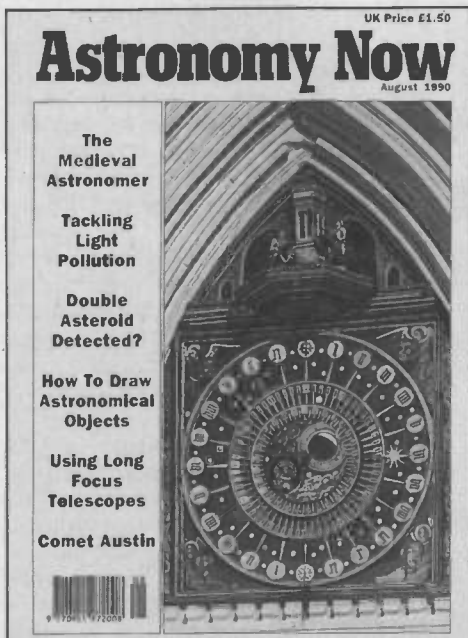

In the August issue:

- The Medieval Astronomer ○
- Tackling Light Pollution ○
- Double Asteroid Detected ○
- How To Draw Astronomical Objects ○
- Using Long Focus Telescope ○
- Comet Austin ○
- ○ ○

plus: News Update - The Night Sky - Sky Watch Down Under and more...

August issue on sale now - price £1.50!

This month we present a varied selection of devices and circuits with many useful and interesting applications. But first we include the modules and a system we did not have space for last month. Fig. 1 shows the component layout for the transistor amplifier Module 10.

MORE MODULES

11 Loudspeaker amplifier

This is the emitter follower amplifier of Fig. 22 last month, but with different component values to give it lower output impedance. The collector current is 20mA and the loudspeaker is coupled to the emitter voltage by a large-value capacitor. This provides an output suitable for a small room with moderately low background noise. (Fig. 2).

Parts required: R1 56k; R2 330 ohm; C1 100n polyester; C2 470µ electrolytic; TR1 ZTX300 npn transistor; LS1 loudspeaker 8-ohm (or crystal earphone); stripboard 63mm x 25mm (Vero 15354).

12 Microphone

Use a ready-made crystal microphone, with the leads stripped so that they can be inserted into the sockets of Module 10. To save expense you may use what is usually catalogued as a 'crystal microphone insert'.

ANOTHER SYSTEM

Intercom

Fig. 3 shows a one-way intercom system, complete with a call buzzer. You need a battery

Fig 1. (right).
Component layout for
Module 10.
Fig 2. (below).
Component layout for
Module 11.

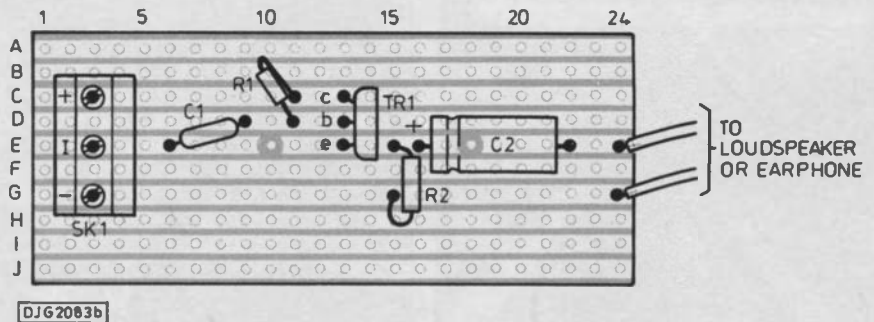
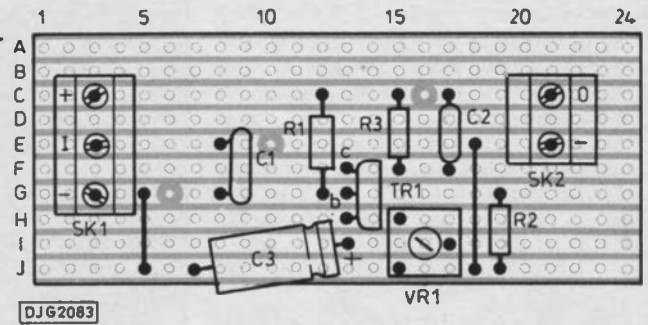

BASIC ELECTRONICS

at each end.

The 0V line is shared by the audio circuit and the call circuit, so only three wires are required between the transmitting and receiving stations. Experiment with this system, substituting other types of amplifier for the specified modules. Can you convert this into a 2-way system? You will need two microphones and two loudspeakers but it makes sense to use the same amplifiers for both stations. You will need to design a switching system to allow each station to be put into 'send' or 'receive' mode.

Fig 3. System diagram of a one-way intercom.

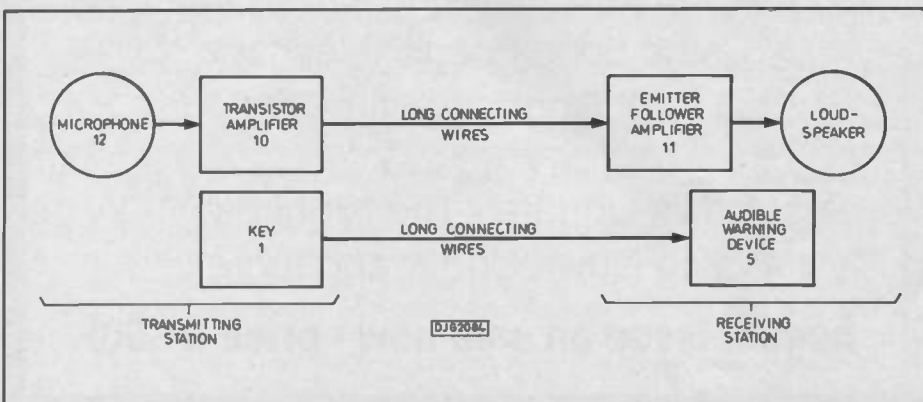

By Owen Bishop Part 9 - Assorted devices and circuits

**Phototransistors,
thyristors and jfets are
important variations on
the transistor theme. We
look at theory and
investigate some of their
actions.**

PHOTOTRANSISTOR

A phototransistor is essentially an ordinary bipolar junction transistor enclosed in a translucent package. Some of them, such as the TIL32, are encapsulated in clear resin. The package is moulded to focus the light on to the transistor. Others, such as the BPX25 and the TIL81, have a metal case with a glass or plastic lens at one end to concentrate light on to the transistor inside. It is instructive to examine a phototransistor of this type with a hand lens. You can see the tiny silicon chip bearing the transistor and the gold leads joining the chip to the external leads. Looking at this reminds us how small the actual transistor is compared with the package which contains it. We can realise how it is possible for several hundred, or even several thousand, transistors to be fabricated on the chip of an integrated circuit.

Fig. 4 shows a phototransistor in symbolic form with collector and emitter terminals but no base terminal. A base terminal is not essential since, as with the photodiode, the action of the phototransistor depends on the minority carriers generated when light falls on it. The more intense the light, the more carriers. The collector-base junction is reverse-biased (see Part 4, April 1990) and so

Fig 4. Symbol for a phototransistor



DJ62037

a small leakage current flows from the collector region to the base. Transistor action occurs, as described in an earlier part of this series, but this time it involves minority carriers. As a result the small base-collector leakage current leads to a very much larger collector-emitter leakage current. In effect, we have a photodiode with built-in amplification. This is why a phototransistor is considerably more sensitive than a photodiode.

Although an external connection to the base is not essential, and is not provided in many types of phototransistor, the switching time of the device can be reduced by providing a base current. If the phototransistor has a base terminal, its symbol is the same as that for an ordinary transistor, with the addition of the two arrows shown in Fig.4.

THYRISTOR

This is a 4-layer device, consisting of alternate layers of p-type and n-type semiconductor material (Fig.5a). It is easier to understand its action if we split it down the middle as in Fig.5b. Then it appears as two interconnected transistors, one npn and the other pnp, as in Fig.5c. In use, the emitter of the pnp transistor (known as the *anode* of the thyristor) is made positive to the emitter of

Fig 5. Thyristor (a) structure, (b) shown as two transistors, (c) transistor connections.

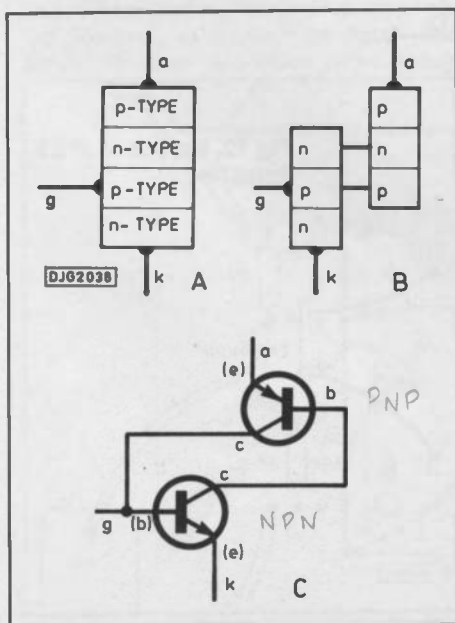

DJ62038

the npn transistor (known as the *cathode* of the thyristor). Since neither transistor is receiving base current, no current flows through the device.

If the base of npn transistor (known as the *gate* of the thyristor) is now made slightly positive, the transistor is turned partly on and collector current begins to flow through it. This current flowing *into* the collector of the npn transistor results in current flowing *out* of the base of the pnp transistor. This turns the pnp transistor on too. Now current flows out through the collector of the pnp transistor, and supplies base current to the npn transistor. The increased current turns the npn transistor more fully on and this in turn draws more current from the pnp transistor, turning it more fully on. In a matter of microseconds, both transistors are fully on and current flows freely from the anode to the cathode of the device. At this point it is no longer necessary to supply an external base current to the npn transistor. In other words, it requires only a brief positive pulse, applied to the gate, to put the thyristor into its fully conducting state.

Once a thyristor is conducting, it continues to conduct for as long as its anode is positive of its cathode. If the supply is removed, conduction stops and it then requires a pulse at the gate to start it again. Because of its transistor nature, the thyristor conducts only from anode to cathode and not in the reverse

Fig 6. Symbol for a thyristor.

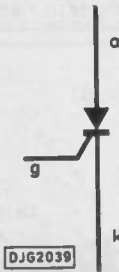

DJ62039

direction. In this respect it is like a diode. Its symbol (Fig.6) emphasises this fact, being the same as the diode symbol with the addition of the gate terminal.

Thyristors have many switching applications. For example, in a photographic flash-gun, a thyristor is used to turn on a large

Fig 7. Part of a flash-gun circuit.

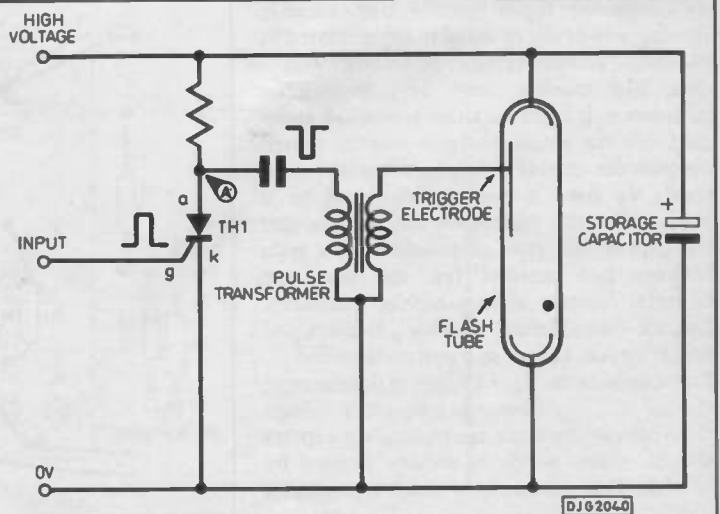

DJ62040

Fig 8. Simple thyristor power-control circuit.

discharge current very rapidly. In Fig.7, a low-voltage pulse applied to the gate turns on the thyristor. The sudden rush of current through thyristor produces a negative-going pulse at A. This pulse is passed through the coupling capacitor to the primary coil. A pulse of several kilovolts is induced in the secondary coil, triggering the flash-tube to discharge.

A frequent application of the thyristor is in power control (Fig.8). The circuit is powered by alternating current. A triggering pulse is applied to the gate at a given point in the positive half-cycle. This turns the thyristor on. Current flows through the thyristor for the remainder of the positive half-cycle, but ceases when the voltage becomes zero. By suitable circuitry (which we do not have space to describe here), it is possible to provide a pulse during each positive half-cycle. By adjusting the timing so that pulses occur earlier or later in the half-cycle, we control the length of time for which the thyristor is conducting (Fig.9). This controls the amount of power supplied to the load. A circuit of this type can be used to control the brightness of a lamp or the speed of a motor. The main disadvantage of this technique is that the thyristor conducts during the positive half-cycle only. This means that no more than half the power is available from the supply. More complex circuits using two thyristors can be used to give greater power or a related device, known as a *bi-directional thyristor* or *triac* can be used.

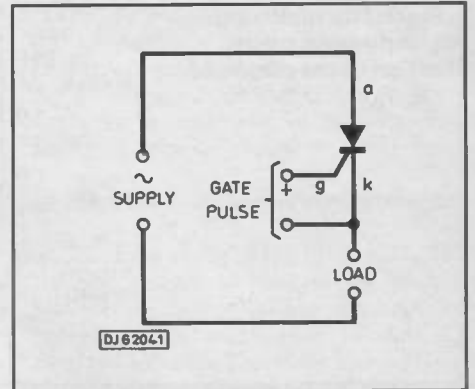

DJ62041

Fig 9. The rectifying and power-control action of the circuit of Fig 8.

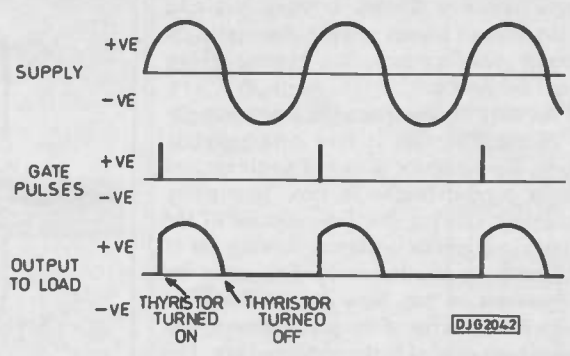

JFET

This acronym stands for *junction field-effect transistor*. We have already met field effect transistors (fets) in an earlier issue. Then we described mosfets, which rely for their action on the field produced around an insulated electrode, known as the gate. The jfets act in a similar way, but rely on the effect of a reverse-biased *on junction*.

An *n*-channel jfet consists of a bar of *n*-type material (Fig.10). The bar is heavily doped, so there are plenty of majority carriers (electrons). This means that the bar has low resistance, typically less than 200 ohms. One end of the bar has a terminal known as the *source* (the source of electrons entering the bar) and the other end is known as the *drain* (through which electrons drain away to the positive supply rail). The gate consists of a region of *p*-type material surrounding the bar (though shown to one side of it in Fig.10, for simplicity). As in a *pn* diode, a depletion region forms on either side of the *pn* junction. Since the *p*-type material is more heavily doped than the *n*-type region, the depletion region lies more in the bar than in the gate. If this *pn* junction is reverse-biased (the *p*-type made negative of the *n*-type), the depletion region becomes wider. The bigger the reverse voltage, the wider the region. The effect of this is to vary the width of the bar available for the conduction of electrons from source to drain. The transistor behaves as a variable resistor, the resistance of which is controlled by the gate potential.

The high degree of insulation provided by the depletion region means that currents flowing into or out of the gate are measured in picoamps, and can be ignored. In other words, jfets, like mosfets, have very high input impedance. It is the variation in *voltage* at the gate, not the amount of gate current, which controls the current through the transistor. In short, we have a *current* controlled by a *voltage*. For this reason, we can not measure the gain of this type of transistor as a ratio between two currents (eg, the base and collector currents as in a bipolar transistor). Instead, we define another measure of amplification, known as *transconductance*:

Transconductance, $g_m = \frac{\text{Change in drain current}}{\text{Change in gate-source voltage}}$

When we measure resistance, we express this in ohms, which is *voltage divided by current*. This tells us how much a conductor

resists the passage of current. With the fet we are measuring conductance, or how much the conductor *allows* the current to flow. It therefore makes sense to have a unit which is *current divided by voltage*. The name for the unit of conductance is the *mho* (*ohm* spelt backwards!), though an alternative name, the *siemens* is usually preferred. In the case of fets, the *mho* or *siemens* are too large for convenience, so transconductance is usually expressed in millimho or millisiemens (mS).

Let us look at a jfet in action as an amplifier (Fig.11). As with the bipolar junction transistor (the 'ordinary' transistor), jfet amplifiers may be built in various ways. The one described here is the *common-source* amplifier, which corresponds to the *common-emitter* amplifier of the bipolar junction transistor. The gate is connected to the 0V rail by the gate resistor R_g . This has a high value to give the amplifier high input impedance (1M). Since the current flowing through R_g is virtually nil, there is no appreciable voltage drop across this resistor, and the gate potential is 0V. When current flows through the transistor, there is a voltage drop across the other two resistors R_g and R_d . Thus the source terminal is at a positive voltage or, to put it the other way round, the gate is negative with respect to the source. This is the condition necessary for operation of the transistor, as shown in Fig.10.

The transistor itself acts to conduct a given current for a given input voltage, V_{in} . In the

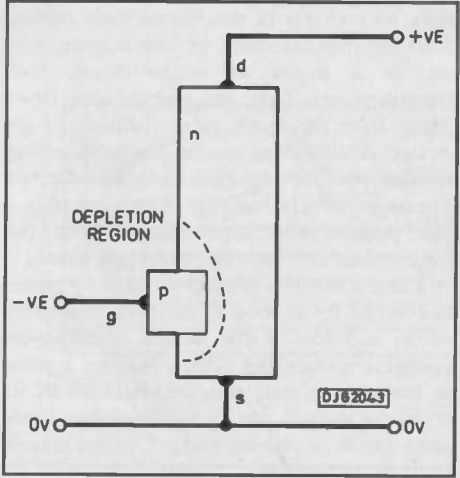

Fig 10. Junction field effect transistor.

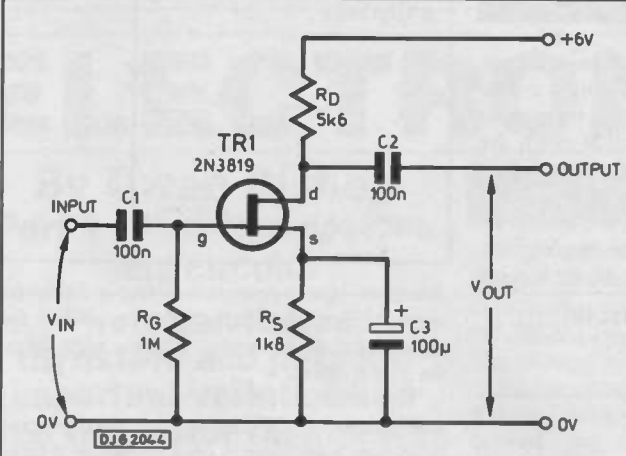

Fig 11. JFET Common source amplifier (Investigation 1).

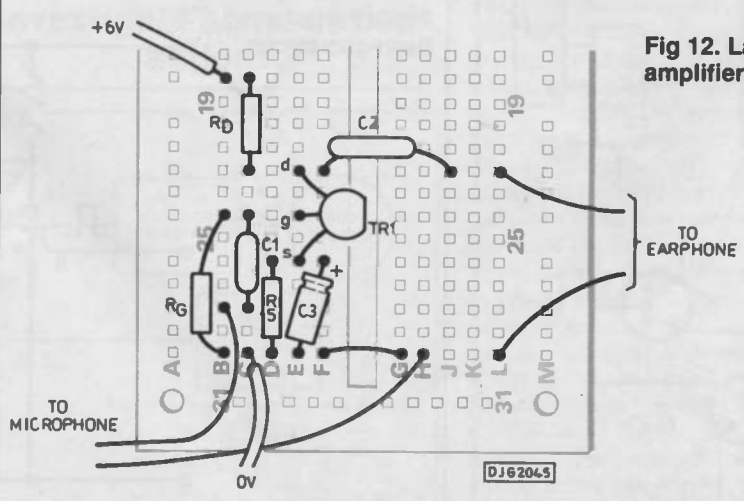

Fig 12. Layout of JFET amplifier.

circuit of Fig.11 the current for a given through a resistor R_g and a voltage develops across it. As explained in a previous issue, we are using the resistor to turn a current into a voltage. This is V_{out} . Thus the amplifier circuit as a whole is a voltage amplifier. To see how the jfet operates in practice, try this investigation.

Investigation 1 - a common-source jfet amplifier

Connect the circuit of Fig.11 as shown in Fig.12. Connect a microphone insert to the input side and a crystal earphone to the output. Preferably, the earphone should be on a long lead, so that it can be in a separate room. Try speaking into the microphone.

How does this amplifier compare in performance with the common-emitter amplifier you tried in a previous part? What is the function of C_3 ? (Hint: try the amplifier with and without this capacitor) What is the name given to this capacitor?

Investigation 2 - jfets and electric charge

The breadboard layout (Fig.13) is similar to that of Fig.12, except that C_1 , C_2 and R_g are omitted. This allows the gate voltage to 'float'. V_{out} is measured with a voltmeter connected between the 0V rail and the drain terminal of the transistor. A small metal plate (eg, a square of aluminium kitchen foil) is connected to the gate terminal. Hang the plate over the edge of workbench.

Take a strip of plastic and rub it with a woollen cloth. You can use the same strips of polythene and acetate sheet as you used in Part 1 of this series. Rubbing charges the strip. Bring a charge polythene strip near the metal plate. What happens to V_{out} ? Repeat, using an acetate strip. What happens now? What can you deduce about the nature of the charge on the polythene strip and on the acetate strip?

Try the effect of charging other types of plastic by rubbing them on fabrics of various kinds.

Try touching the metal plate with your finger. What happens? Try this again while you are touching an earthed conductor. Walk around the room on a nylon carpet, wearing

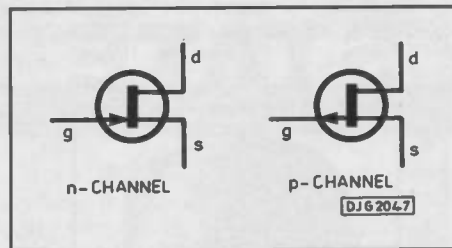

Fig 14. JFET symbols.

plastic-soled or rubber-soled shoes; touch the plate again. What happens?

The type of jfet used in the investigations is an *n-channel jfet*. Less frequently we use *p-channel jfets*, in which the bar is p-type material, the gate is n-type and conduction is by holes (Fig.14).

CONSTANT CURRENT SOURCE

A useful circuit element is one that generates a constant current, independently of the load and the supply voltage (within limits). Such a circuit is shown in Fig.15. This one makes use of one of the properties of the bipolar junction transistor. When we investigated the action of the transistor in a recent issue, we found that, for a given base

Fig 15. Constant current source.

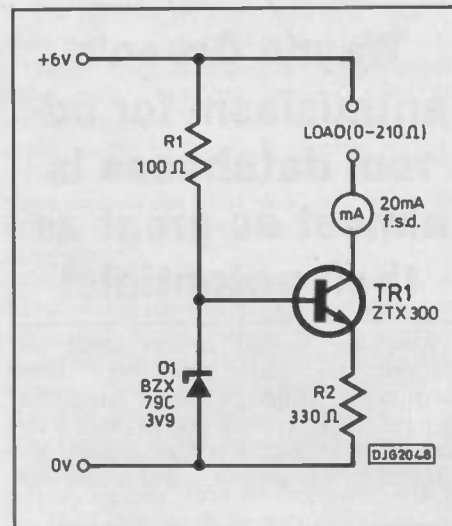

current, the collector current remains more-or-less constant over a wide range of collector-emitter voltages. Even if you do not need to use a constant current source, studying how it works is an easy way of revising certain aspects of electronic circuits.

Investigation 3 - a constant current source

Set up the circuit of Fig.15, as in Fig.16. A 100-ohm resistor is used as the load, R_L . Measure the current through the load. Now increase the load to 150-ohm, 180-ohm, 220-ohm, and 330-ohm. Record the current through each load. Reduce the load to 68-ohm, 47-ohm, and 27-ohm. Measure the current through each load.

With 27-ohm as the load, reduce the supply voltage to 4.5V by tapping the battery holder so as to use only three of the four cells. This reduces the supply voltage by 25%. Is the current through the load also reduced by 25%?

The zener diode holds the base of TR_1 at a steady voltage. What is the voltage across R_1 ? What is the voltage drop (V_{be}) between the base and emitter of the transistor? Calculate the current through R_2 . The maximum permissible value of the load resistor is that for which the voltage drop across it is equal to the drop across R_1 . If it was greater, the collector-base junction would be reverse-biased and the transistor would not work. Calculate the maximum load resistance.

To be continued next month, when we shall look at Unijunctions, more reference sources and power supplies, and discuss the investigations.

POINTS ARISING

Part 3 March 90

Several words were omitted from the first paragraph on page 26. This is how it should have read:

When a steady current (ie direct current) flows through one coil it generates a magnetic field in the core. But, since the current is constant, the magnetic field is constant and has no effect on the other coil. If an alternating current is passed through the one coil, this produces an alternating magnetic field.

Fig 13 (left). Layout for Investigation 2.

Fig 16 (below). Layout of circuit in Fig. 15.

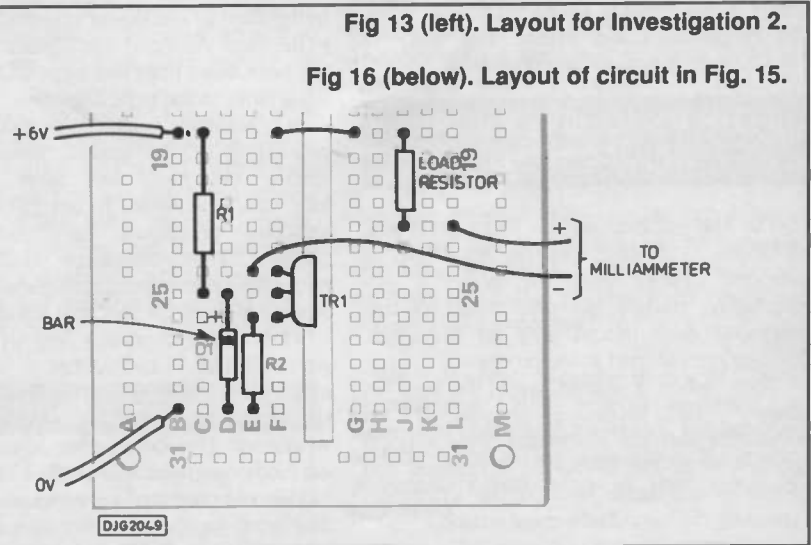
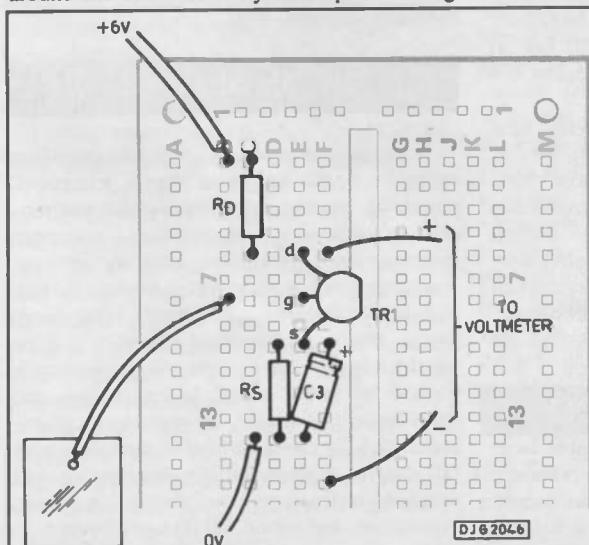

With the costs of health care escalating, the health industry is looking for possible economies. In this vein (pardon), there is a trend toward educating doctors to be specialists and repair people rather than being information processors.

In the past, doctors were trained to memorise vast quantities of information as a way to help them with the diagnosis of medical problems. With information becoming easier to access via computers, and increasing computer portability, there is a lessening need for doctors to have to depend on their memories.

In the last few years we've seen more and more home medical guides being published, but these have several drawbacks...not the least of which is their expense. Depressingly few people are willing to invest in these books as a safety precaution for their families.

Then there's the difficulty of finding what you need in these books if you don't already know what's wrong. The diagnostic process is often too complicated for this approach to be helpful. I suppose we can add to the mix a

STATE



SIDE

get this critical confidential information past the conscious mind, which acts like a censor. It turns out this is an ideal application for a computer.

By attaching a sensor to a finger to read changes in moisture and pulse rate, it's possible to set up an effective lie detector system which will help a computer deal directly with the subconscious mind. When we're anxious about something, even subconsciously, our palms sweat. This was originally designed to give our ancestors better traction for climbing trees when things got tense. This automatic mechanism still works and can easily be measured with a differential ohmmeter circuit connected to a computer.

We've had psychiatrist-imitating computer programs (such as Eliza) for over twenty years, so all we need to do is adapt them to this application and we'll have a quick and dependable psychological diagnostic system.

By using a computer to chase down the traumas which have contributed to an illness, there's much less anxiety over the reaction of a doctor to things which a person might

HOME DATA SYSTEMS

low level of literacy in lower income groups and an inability to cope with what is often rather technical language.

We do have some information systems developing which are better geared to this kind of application...such as the cd-rom. We're able to cram an enormous amount of information on a compact disc these days. One friend of mine has just put out a cd-rom full of Macintosh software with 719 megabytes of data. That's over 350,000 pages of data, all nicely cross-indexed in depth.

A medical text in fairly plain language, complete with a good index which would allow us to search for symptom combinations and which could even include an interactive diagnostic program to be downloaded into ram, is now practical.

The first use of such a new product would be for medical offices, hospitals and clinics, where it would help lower diagnostic costs. But as cd-rom reader prices drop, this will even become practical for households.

THE PSYCHOLOGICAL COMPONENT

The medical industry has had a great deal of trouble in dealing with the mind and its profound control over the body. It has reluctantly, grudgingly, come to accept that the mind does indeed play an important, possibly critical, part in the process.

Thus, when a doctor wants to treat an illness, it's becoming recognised as imperative that the associated psychological component of the illness be diagnosed and treated at the same time as the symptoms caused by the mind-body combination.

Wayne Green's enthusiasm for cd-rom databases is almost as great as their potentials!

Alas, our medical schools aren't yet equipped to deal with this added complication, so though doctors realise that the mind and its problems may be either at the heart of an illness, or at least substantially contributory, they are unequipped to deal with this.

This is an area where computer technology in the form of intelligent systems is beginning to develop. Artificial Intelligence (AI) has, so far, been more hope and hype than reality, but it's a move in the right direction.

As scientists make progress with their unwinding of the genetic genome, they're finding out more and more about how inherited weaknesses in our DNA molecular structure predispose us toward certain illnesses. This information would obviously help give a computerised diagnostic system an edge in looking for potential health problems.

How can a computer help us to find the psychological component which has contributed to triggering an illness - perhaps taking the easy path provided by a genetic weakness? This information is available from our subconscious minds, but it's cleverly hidden and protected by our conscious minds. The work for the computer then is to help us

consciously want to hide. Less embarrassment. This makes the discovery of the underlying psychological factors precipitating an illness much easier to uncover. Indeed, experiments in taking patient histories via computers were pioneered in the UK and found to be substantially less stressful than questions from a nurse or doctor. This resulted in more honest answers.

By combining the data base made possible by cd-roms and an interactive diagnostic program, we'll have a powerful tool for families to use at home to help prevent illness or speed their recovery.

When the underlying psychological component of an illness - or even what seems like an accident - are uncovered, it is possible to greatly speed the recovery. And this holds true even for bruises, burns, and cuts, which can often heal in a fraction of the time normally required.

HOME REPAIRS

Some people invest in an almost unending series of books on home repair. Electrical, plumbing, heating, refrigerators, dishwashers, air conditioners, thermostats, security systems, lawn care, tree pruning, roofing, leaks, windows, wallpapering, kitchen design, bathroom fixtures, furniture refinishing, patios, pools, gardens, etc. Wouldn't it be worthwhile to have everything you ever wanted to know about home repairs and enhancement available, all thoroughly cross-indexed? This can be available, complete with full colour, high definition illustrations and detailed instructions on design, building, installation, and repair...all on one cd-rom.

You want to know what's available in intercom systems and how to install them? It's there. Maybe you'd like a couple loudspeakers on your porch or patio. No problem.

CALL THE LAWYER?

No, look up your legal question on a Home Legal Advice cd-rom. For the price of one hour at your lawyer's office...or even on the phone...you can have the answers to a hundred thousand legal questions all at hand and easy to find.

Small businesses will find that such a resource will save them an incredible amount on questions on contracts, licences, and so on. A cd-rom can have hundreds of legal forms all ready to be used. Wills, apartment rentals, leases, home buying details, traffic violations, etc.

BOOKS

Wouldn't you like to have an in-depth index to every book published, complete with a thorough cross-index so you can find what you're interested in? It could even have reviews reprinted from magazines and newspapers to help you decide which book you want. The front covers could be shown in full colour...plus even some commentary or a sales pitch by the author in his or her own voice.

The cd-rom could also have an interactive program built in for maintaining your own library. You'd unload this program into your hard disk drive and keep your own cross-indexed library data there.

MAGAZINES

There are thousands of special interest publications, but how can you find the ones you'd like to read? Only a few ever make it to the newsstands, so many great magazines are difficult to find out about. A cd-rom index to magazines and newsletters would let you look for those which may be of particular interest to you. I subscribe to five skin diving magazines, but I'll bet there are a dozen more around the world which I might enjoy if I knew about them.

In the music field there are publications devoted to calliope, bluegrass, theatre organ, and other music special interests. Most of these are nicely done, but very obscure.

You wouldn't believe how many specialised travel publications there are. I get over a dozen, but there are hundreds more.

If you're a Macintosh fanatic (like my wife, Sherry), then you'll want to know about the dozens of Mac publications. If you're going to get into home computing or desktop publishing, you're going to need all the information you can get.

Would you believe there are over 500 magazines and newsletters devoted to amateur radio? Packet, moonbounce, amateur tv, weather satellites, ham radio satellites,

radio teletype, you name it and there's a publication somewhere...or, more likely, three.

MUSIC

How about a cd-rom index to every available phonograph record? Well, cds these days, now that lps are blowing away. This would enable you to find out what's available by any composer, performer or group. You might want to find hammered dulcimer, steel drum, or carousel band organ music.

I have such a cd-rom already available which lists over 45,000 cds and has in-depth reviews of several thousand of them which have been printed in my publications over the last five years. It also provides a summary of over one million reader evaluations of many other cds. There are many full colour cd covers and even sound samples with full digital audio sound quality.

PET TOPICS

How about one for pet lovers? This would provide pet owners with information on selecting, buying, feeding, training, grooming, health maintenance, etc. It could include reprints of important articles from pet magazines...thousands of them, all indexed. It would tell how to photograph pets, how to show them, and what to watch for healthwise.

How about a cd-rom for home electronics? This could cover the various types of telephones...how to select, buy, install and repair them. VCRs, hi-fi systems, radios, vacuum cleaners, fax machines, perhaps a video camera for your door, etc. How do Nicads work and how often should they be charged?

How about car repair and maintenance? A cd-rom could take you through just about any emergency. It could show you how every model car is designed and what generally fails first with them. Would you like to install a cd player in your car? Which models will fit? How can you do the installation yourself and save hundreds of pounds? How about car security systems? How do they work? Which are best? How much do they cost? How do you install them? Which tyres work best on which cars? Everything you ever wanted to know about your car, right there waiting for you...in detail.

You're into skin diving? Then you'll want to know how experts rate various diving vacation spots around the world. You'll want to know the details on the latest diving computers, watches, fins, snorkels, masks, regulators, wet suits, etc. You'll want to read reviews from a dozen diving magazines on new products and on dive locations. You'll want to see full colour, high definition pictures of fish.

MOVEABLE FEASTS

Maybe you're into movies. How about a cd-rom index to every current and old movie,

complete with reprints of reviews? You'd want good still shots from them, pictures of the stars and supporting actors. You'd want their bios too, all indexed. This would help you find the best movies for video rental and not waste your time on B-movies.

For people who have an interest in more than tv dinners, a cooking cd-rom could provide tens of thousands of recipes, complete cooking courses for breads, pastries, salads, curries, desserts and so on. It could cover how to grow and prepare herbs...and when to use them. Do you know how to make baklava? Bialys? Spring rolls? What kitchen accessories should you get...and why? Where can you get the ingredients? How about mail order suppliers of speciality food products?

ENCYCLOPAEDIC

Once we start getting cd-rom players into the home, we're going to have a whole new industry supplying encyclopaedic information on almost any subject. In a few years I believe this is going to be a big industry...in case you're looking for an industry where you can get in early.

It shouldn't be long before most home cd players are beefed up to handle the fast, frequent searching required for cd-rom use, so the better cd players will also play cd-roms. This might add 20% to the cost of the player.

On the other hand, if digital tape ever gets going, it could replace cd-roms for data handling applications. One two-hour dat can hold two to three times as much information as a cd...and it has the benefit of being able to be updated. Cd-roms are optical devices, so one needs to buy a new cd-rom disc in order to get an update. And there are very few data bases which don't require frequent updates. We'll see how that develops.

Dats could be updated via satellites, fibre optics or just plain swapping of the cassettes. Cd-roms, which cost about 50p to make, may do better as throw-away items when replaced...like old phone books.

ON-LINE DATABASES?

Sure, we'll probably see some of this information available to computers over the telephone, but the slowness and cost of on-line systems as compared to home use will limit their sales. Remember, as soon as computers came down in price we saw on-line computing services blow away.

Ten years from now, when you enviously see lots of new millionaires, don't say I didn't warn you. I've called the turn early on cellular telephones, microcomputers, and the compact disc. Many of those who followed my advice are filthy rich today. The down-sides to being rich are vastly overrated.

PE

Dr. Wayne Green lives in New Hampshire, USA, where he runs a successful publishing company. His hobbies include scuba diving and skiing. He is also passionately interested in the future of education.

PRACTICAL ELECTRONICS CLASSIFIED

Reach thousands of serious electronic and computer enthusiasts. Advertise in PE Classified pages: Rates 20p per word or £8.50 per single column cm (plus VAT). All classified advertisements must be pre-paid. Send your copy with the remittance (payable to Intra Press or payment by Visa or Access accepted) to: Practical Electronics, Intra House, 193 Uxbridge Road, London W12 9RA. Tel: 081-743-8888. Fax: 081-743-3062
LET PE WORK FOR YOU!

EDUCATION

FULL-TIME TRAINING COURSES

2 YEAR

BTEC NATIONAL DIPLOMA

Electronics and Communications Engineering

(TV, Computers, Programming, IT)

1 YEAR

BTEC NATIONAL CERTIFICATE

1. Electronic Equipment Servicing

(TV, Video, CCTV)

2. Computing Technology

(Microprocessors, DataComms, Interfacing)

3. Information Technology

(Telecomms, Satellite TV, Networks)

4. Software Engineering

(Assembler, BASIC, Pascal, CAD/CAM)

★ Those eligible can apply for E.T. grant support★

★ An equal opportunities programme ★

COURSES COMMENCE

Monday 17th September 1990

LONDON ELECTRONICS COLLEGE

Dept: AA, 20 Penywern Road, London SW5 9SU. Tel: 071-373 8721

Start training now for the following courses.

- Telecomms Tech C&G 271
- Radio Amateur Licence C&G
- Microprocessor
- Introduction to Television

Send for our brochure - without obligation or telephone us on 06267 79398 (Ref: PE8/90)

Name.....

Radio & Telecommunications Correspondence School, 12 Moor View Drive, Teignmouth, Devon TQ14 9UN

EDUCATION

TRAIN FOR THE 21ST CENTURY

TRAIN FOR A CAREER IN COMPUTER MAINTENANCE

- ▶ ATTRACTIVE SALARIES & BENEFITS
- ▶ CAREER DEVELOPMENT & PROGRESSION
- ▶ VARIED & INTERESTING WORK
- ▶ SECURITY
- ▶ MOBILITY
- ▶ PLEASANT WORKING ENVIRONMENTS
- ▶ JOB SATISFACTION & INVOLVEMENT
- ▶ STATUS

These are some of the benefits of a career in Computer Maintenance.

A seven week course at Cerco Training Limited provides the gateway to employment in this rapidly expanding sector of the computer industry.

If you are aged eighteen or over and pass our aptitude tests, Cerco can arrange sponsorship or affordable, easy payment terms to cover course fees, and we provide a free placement service for all course graduates.

For full details phone Roger Parr on 0270 626300 or write to Cerco Training Limited, Alvaston Business Park, Middlewich Road, Nantwich, Cheshire CW5 6PF.

MONEY BACK GUARANTEE OF EMPLOYMENT TRAINING



TRAINING IN MICROPROCESSOR SYSTEMS

Enhance your career prospects in this dynamic growth area of technology. There are immediate vacancies for electronics technicians with HNC qualification.

One year full time courses commencing on 17th September 1990 are offered by ASTRA TRAINING SERVICES LTD., The UK's largest training provider, at MILTON KEYNES.

UK residents with electronics qualifications or experience may apply.

Our intensive courses combine academic and practical training with industrial experience.

This is a Training Agency funded equal opportunity course and training allowances will be paid. Please phone 0908-670001 for an application form and information pack or write to:

TONY WHITE
 MILTON KEYNES SKILL CENTRE,
 CHESNEY WOLD, BLEAK HALL
 MILTON KEYNES MK6 1LX

IS YOUR ADVERTISEMENT A TIGHT SQUEEZE?

STRETCH OUT IN THE DISPLAY PAGES OF PE!
 PHONE DAVID BONNER FOR DETAILS ON 081-743-8888

RETAILERS

EDINBURGH

OMNI ELECTRONICS

stock a wide range of electronic components at 174 Dalkeith Road Edinburgh EH16 5DX
 Tel: 031 667 2611
 Open Mon-Fri 9am-6pm Sat. 9am-5am
NEW CATALOGUE OUT SOON
 Price is just £1.50
 Contact Omni Electronics now for details

MANCHESTER

THE ELECTRONICS SHOP

We stock a large range of electronic components, test equipment, telephone accessories, computer accessories, microphones, speakers, disc-lighting, mixers, meters, stylis, so call in and have a look around.

29 Hanging Ditch, Manchester M4 3ES
 Telephone: 061-834-1185
 Fax: 061-833-2969

SOUTHSEA

ELECTRONIC COMPONENTS

EVERYTHING FOR YOUR NEXT PROJECT
 THE BIGGEST DISPLAY IN THE SOUTH IS AT

FRASER ELECTRONICS

42 ELM GROVE ★ SOUTHSEA ★ HANTS
 Telephone: 0705-815584

Barclaycard

STAFFORDSHIRE

COMPONENT SOLUTIONS Ltd.

"answering your component problems"

Unit 62, Enterprise Centre, Bedford Road, Stoke-on-Trent, Staffs., Tel: 0782 287038

Resistors 1/4 W 5% carbon (E12) 1p metal film 1%3p
 Resistor Pack 85 different E12 values + zero ohm link total content
 1000 resistors£8.95
 LEDs red/green 3/5mm6p each. Yellow 11p
 Cable ties 75mm1p each £5.95/1,000 £49.50 per 10,000
 Stepping motor 4 phase 12v 7.5 step 50 ohms£8.95
 SAA1027 stepping motor driver chip£3.95
 FM transmitter kit good quality sound£7.94
 High quality photo resist copper clad epoxy glass boards
 Dimensions single sided double sided
 3x4 inches£0.95
 £1.07
 4x8 inches£2.40
 £2.68
 6x12 inches£5.37
 12x12 inches£10.66

Special Offers
 Computer Grade Capacitors with screw terminals 38000uf 20v £2.50
 8700uf 10v £1.95, 6800uf 15v £2.95, 10000uf 16v £1.50
 7 segment Common anode led display 12mm£0.45
 LM2931A TS.0 Low drop out 5V regulator T0220 package£0.85
 BS250 P channel MOSFET £0.45, BC559 transistor£3.95 per 100
 74LS05 hex inverter £10.00 per 100, used 8748 Microcontroller£3.50
 Stereo L/W/M/FM Tuner pre-amp assembly complete with volume/tone
 controls and tuning scale Brand new in makers carton£5.95, family £2.50
 Circuit diagram description and setting up procedure for tuner
 assembly described above £0.50. 5 digit 6v electromagnetic counter
 £1.95
 Hour counter (used) 7 digit mains 240V AC 50Hz£0.95
 LCD display 16 digit 7x5 dots dot matrix£2.50
 Query keyboard 58 key good quality switches£5.00
 25p for P&P per order (VAT inc.)
 wide range of CMOS TTL 74HC 74F Linear transistors kits
 capacitors, resistors tools etc always in stock
JPG Electronics 276 Chatsworth Road Chesterfield S40 2BH
 Access orders (0246) 211202. Callers welcome

Carbon Film Resistors 1/4W E24 series 0.51R to 10MΩ - 1p
 100 ohm per value - 75p 1000 off in even hundreds per value - £7
 Metal Film 1/4W 10R0 to 1MΩ 5% E12 series - 2p 1% E24 series - 3p
 1/2Watt metal/carbon film E24 series 1R0 to 10MΩ - 11p
 1 Watt metal/carbon film E12 series 4R7 to 10MΩ - 5p
 BC107/8/9 - 12p BC547/8/9 - 8p BC182L 184L - 10p
 BFY50/51/52 - 20p 2N3055 - 50p TIP31A, 32A - 25p TIP41, 42, - 40p
Tantalum bead subminiature electrolytics (Mids/Volts)
 0 1.35, 0.22 35, 0.47 35, 3 316, 4.7 16 - 14p 4.7 35 - 15p
 2.2 35, 4.7 25, 10 5 - 15p 4.7 35, 6.8 16 - 16p 10 16, 22 6 - 20p
 22 16 - 30p 33 10 - 30p 47 10 - 35p 100 6 - 40p
Aluminium Electrolytics (Mids/Volts)
 1 50, 2 250, 4 7 25, 4 7 50, 10 16, 10 25, 10 50 - 5p 22 16, 22 25 - 6p
 22 50, 47 16, 47 25, 47 50 - 6p 100 16, 100 25 - 7p 100 50 - 12p
 100 100 - 14p 220 16 - 8p 220 25, 220 50 - 10p 470 16, 470 25 - 11p
 1000 25 - 18p 1000 35, 220 25 - 22p 4700 25 - 70p
Miniature Polyester Capacitors 250V Wdg. Vertical Mounting
 01, 015, 022, 033, 047, 068 - 4p 0.1 - 5p 0.15, 22 - 8p 0.47 - 8p
Mylar Capacitors 100V Wdg. Vertical Mounting E12 Series
 1000p to 8200p - 3p 01 to 068 - 4p 0.1 - 5p 0.15, 0.22 - 6p
Subminiature Ceramic Plate 100V Wdg. E12 Series Vertical Mounting
 2% 1P8 to 47P - 3p 56P to 330P - 4p 10% 390P to 4700P - 4p
 Ceramic plate disc E6 Series 50V 22P to 047 - 2p
Polystyrene Capacitors 63V Wdg. E12 Series Axial Mounting
 10P to 820P - 3p 1000P to 10,000 - 4p 12,000P - 5p
 1N4148 - 2p 1N4002 - 4p 1N5404 - 14p W01 bridge - 25p
 0A91 - 8p AA143 - 8p W005 - 20p 1N4006 - 6p
Zener diodes E24 series 3V3 to 33V 400mW - 8p 1 watt - 12p
 L.E.D's Red, Green & Yellow 3mm & 5mm - 10p 8mm - 35p
 20mm fuse 0.1A to 5A quick blow - 5p Anti Surge - 6p
 High Speed drills 0.8mm, 1.0mm, 1.3mm, 1.5mm, 2mm - 30p
 Expo Reliant drilling machines 12V d.c. with improved 3-jaw chuck 6.50
 Nicads AA - 80p HP 11 - £2 PP3 - £4.20 Universal Chargers - £8.50
 Glass reed switches single pole make contacts - 8p Magnets - 12p
 VAT inclusive. Return postage 25p (free over £5) Lists free

THE C.R. SUPPLY CO.,
 127 Chesterfield Road,
 Sheffield S8 0RN. Tel. 557771.

PE WORKS FOR YOU!

Cooke International
 DO YOU WANT USED
 SCOPES, SIGNAL GENERATORS, POWER
 SUPPLIES, POWER METERS, DVM'S,
 OSCILLATORS, ATTENUATORS,
 TEST EQUIPMENT.

Contact: Cooke International, Unit Four,
 Fordingbridge Site, Main Road, Barnham, Bognor
 Regis, West Sussex PO22 0EB.
 Tel: 0243 545111, Fax: 0243 542457
 Wide range of items available. Send for lists.

CAMBRIDGE COMPUTER SCIENCE LTD

10MByte Winchester, used, 3 months Wty, £42.00 each
 5.25" Disk Drives, 80 Track DSDD £34.00 each
 5.25" drive cases, room for drive, PSU and fan £10.00 each
 5.25" Disk Drives, 80 Tk DSDD Used No Wty £15.00 each
 (The £15.00 drives are sold on a strictly "as is" basis)
 5.25" Disks, DSDD, 48kpi boxes of 10 £3.00/box
 40W PSU 5V 3.75 A, 12V 1.5A-12V 0.4A cased with on/off switch £10.00 each
 Gould PSU 0-30V @5A Limited quantity only at £45.00 each
 Single Data lead (BBC Micro to Disk Drive) £2.00 each
 Dual Data lead (BBC Micro to 2 Disk Drives) £4.00 each
 Power lead (BBC Micro to Disk Drive) £2.00 each
 Dual power lead (BBC Micro to 2 Disk Drives) £4.00 each
 68000 CPUs (The first orders get 10MHz chips) £3.50 each
 8086 CPU chips £2.00 each
 Z80A CPU, CTC, P10 £1.20 each; DMA £2.00 £4.50 all 4
 74LS TTL, pick and mix, buy 10 or more for £0.12 each
 Types available: '00 '02 '04 '08 '11 '13 '15 '20 '21 '26 '27 '30 '32
 '33 '38 '42 '75 '83 '96 '107 '109 '122 '132 '136 '139 '145 '151
 '153 '157 '158 '163 '164 '166 '191 '193 '298 353' 365 £70
 2764 EPROMS (Ex-equipment) £1.00 each
 27128 EPROMS £2.50 each
 27C256-25 EPROMS £2.50 each
 256K Byte DRAM Modules, removed from equipment £6.00
 6116 2K Byte SRAM £1.10 each
 6264 8K Byte SRAM -15 £3.00 each -12 £3.80 each
 65256 32K Byte rams £7.00 each
 8K Byte NV ram chips £3.00 each £10.00 four
 20 pin dll low profile IC sockets £0.50 (ten) - £4.00 (100)
 40 pin dll low profile IC sockets £0.60 (ten) - £5.00 (100)
 CPU cards (Newbrain) Z80 CPU, 3 EPROMS & 80 + mostly 74LS ICs. £2.00 each
 Keyboard, 100 keys on board LCD & micro if £8.00 each
 Metal Project Boxes drilled & painted but unused 28 x 32.5 x 5cm £5.00 each
 Toroidal mains transformer 12V 4A & 0.4A, 12-0-12 @0.1A & 2A
 9-0-9 @0.2A £4.00 each - £6.00 for 2 - £8.00 for 3
 Video Tapes, E180 VHS £2.50 each
 Smoke detectors, small size £7.00 each
 Smoke detectors, large with escape light and pause feature £13.00 each
 Prices include postage. Add 50p to orders below £5.00.
 All items new unless stated. Add 15% VAT to all prices.
 Send an SAE for our latest list or for more info.
Dept PE, 374 Milton Road, Cambridge, CB4 1SU Tel:
0223 424602 or 0831 430496 or 0831 430552
 (Please note mail order only)

**Practical
 Electronics
 Classified
 Works!**

10th May 1990

Dear Mr. Bonner,
 Just a line to say that
 I was delighted with
 the response from my
 advert in the June
 Practical Electronics;
 the number and quality
 of replies exceeded my
 best expectations.

Yours sincerely,

 M. H. C. Lewis
 Newcastle-upon-Tyne

**Phone David Bonner
 on 081-743-8888 for
 details!**

**30 DAYS GUARANTEE. PLEASE ADD VAT.
 CHECK AVAILABILITY & CARRIAGE COSTS.**

AUDIO GENERATOR 10KHZ TO120 KHZ SINE CARD SO £115
 SIGNAL GENERATOR 144H - 10 KHZ TO 72 MHZ £22.50
 MARCONI TW2015 AM/FM 10-520MHZ SIG GEN £225
 MARCONI 2002AS 10KHZ - 72MHZ SIG GEN £100
 BRIDGE MEGGERS/VARLEY/MURRAY LIST AT £850 OUR PRICE
 AS NEW £85 YES £85

COMPUTER FIELD
 CALCOMP DIGITIZERS JUST IN MODEL 2000 12 INCH X 12 INCH
 SPECIAL PURCHASE SO ONLY £90
 VARIOUS MODEMS FROM £40
 CGA, EGA, AND VGA STOCK AND PRICES CHANGE FAST SO
 TELEPHONE. £45
 PRINTERS WIDE RANGE FROM £45
 COLOUR PRINTERS
 SIGMET IMX JET £120
 DATA GEN RIBBON £140

FANS
 5 INCH 125 VOLTS £2.50
 5 INCH 240 VOLTS £4.50
 3 INCH 240 VOLTS £6.50

Try Our Bumper Component Pack!
 ICs - Capacitors - Diodes - Leds
 Bridge Rectifiers, and other components etc.
 Only £3.00 + £1.00 P&P

**A. WOOD. NORTH WEST.
 94 WORSLEY ROAD, FARNWORTH
 TEL: BOLTON (0204) 71795
 OPEN 7 DAYS A WEEK**

**SURPLUS/REDUNDANT ELECTRONICS
 COMPONENTS WANTED**

ICs - Tuners - Transistors - Valves - Diodes etc - any quantity
 considered - immediate payment.

ADM ELECTRONICS SUPPLIES
 Tel 0827 873311 Fax: 0827 874835

FOR SALE
 100 new resistors assorted £1.00.
 Buy £5.00 worth and receive other type
 components free!
 Contact: Ray, 71 Tothale Turn, Liverpool 27 L27 4YO

**H.S.S. TAPS & DRILLS
 INDUSTRIAL QUALITY**
 Set includes 1 drill + 1 tap
 Sizes available M3, 4, 5 & 6
ONLY £3.49 + 50p p&p.
 Send cheque to
R. Scott, 28 Hunter Road, Nottingham, NG5 6QZ
 Send SAE for quote on all
 your engineering supplies.

N.R. BARDWELL LTD

200-Signal diodes 1N4148£1.00
 100-Rectifier diodes 1N4001£1.00
 100-Zener diodes 6V8 400mW£1.00
 30-Assorted Dll sockets up to 40 pin£1.00
 30-Assorted Sockets/Concs. Dll, Edge, I.D.C., Header etc£1.00
 30-Transistors BC478£1.00
 20-Miniature SPIC0 Slide switches£1.00
 20-Magnetic ear pins + lead and Plug£1.00
 75-Electrolytics 4.7uF 63V£1.00
 1-10 Watt stereo amplifier - 4 controls and data£2.95
 Prices include VAT, postage 60p. All items new.

Many other lines in stock.
 Shop open Mon/Sat 9.30-5.30. Lists S.A.E.
288 ABBEYDALE ROAD, SHEFFIELD S7 1FL
 TEL: (0742) 552886 FAX: (0742) 500689

TURN YOUR SURPLUS
 ICS transistors etc into cash, immediate
 settlement. WE welcome the opportunity to
 quote for complete factory clearance.
 Contact:
COLES-HARDING & CO.,
 103 South Brink, Wisbech, Cambs.
 ESTABLISHED 15 YEARS
 Tel: 0945 584188 - Fax: 0945 588844

COMPONENTS

ELECTRONIC COMPONENTS

Send for our 1991 Catalogue!
Contains 000's of product lines
including SMD components.

Send cheque or P.O. for £1.80
to:

SARM DIGITAL

13, Pearl Street, Macclesfield,
Cheshire SK10 2AL

Mail Order Only.
Prop. N. Farrar

KITS

VELLEMAN KITS

Over 100 Project kits in stock.
Send 50p for 1990 Catalogue plus
price list.

Electronic Retailers wanted
throughout the country with a view
to stocking our product.

High Q Electronics
PO Box 14810
London NW7 4RF
Tel: 0707-263562



MISCELLANEOUS

**SATELLITE
SELLING SPREE**

90cm Parabolic Antennas	£59.00
(including AZ-EL mount)	
Receivers from	£49.00
LNB's from	£37.00
Universal mounts	£ 9.25
Cable "1F" RG6 £.0.35 per mtr.(30 mtr. rolls)	
Filmnet Decoders	£52.00

For Orders and Full details contact:

Zeta Satellite
Telephone No: 0625 583850

**III C.E.S. N.W.
FOR ELECTRONIC COMPONENTS**

**TEST EQUIPMENT REPAIRS
IBM PC-ACCESSORIES
AT DISCOUNT PRICES**

Let us source that difficult to find
component for your kit or project.
Send for details of all our services.

**Appt. 2, No. 8 Merlon Gardens,
Colwyn Bay, Clwyd
North Wales LL29 7PR**

Tel:0492 533083 Fax: 0492 534716

C.S. COMPONENTS (Est. 4 years). Suppliers &
stockist of electronic components, electronic
valves, military equipment and spares. Obsolete
and hard to find products are our speciality. C.S.
Components, Southfield House, 11 Liverpool
Gardens, Worthing, West Sussex BN11 1R

SURVEILLANCE

Surveillance devices, lasers, Tesla
coils, scramblers, ultrasonic and many
more, over 150 designs. Send SAE to:
Plancentre, Old Wharf, Dynock Road,
Ledbury HR8 2HS

MICROTRANSMITTERS, VHF, Phone
transmitters Bleepers, Vox, Phone
recorders, kits or built. Also plans for
handheld EHT units, sonic guns etc.
SAE to: P.O. Box 55 Cannock, Staffs
for free list.

NEW VHF MICROTRANSMITTER KIT,
tuneable 80-115 MHz, 500 metre
range, sensitive electret microphone,
high quality PCB. **SPECIAL OFFER**
complete kit **ONLY £5, assembled and
ready to use £8.95** post free. Access
orders telephone 021 411 1821.
Cheques/ P.O.'s to: **Quantek
Electronics Ltd, (Dept P.E.), 45a
Station Road, Northfield,
Birmingham, B31 3TE**

Voice/Sound activated switches easy
to follow diagrams and uses, only £1.00.
Components and PCBs available from
Herrington, 63 Home Farm Road,
Hanwell, London W7 1NL

**BP 34 wanted. Practical Repair and
Renovation of Colour TV's.** Good price
paid for book or photocopy. Contact:
B.S.Smart 27 Knowle Road, Maidstone, Kent
Tel: 01-945-5338 (day) or 0622 51501 (eve.)
**My Fortel CCDHP Time Base Corrector
needs repair.** Service information
literature/sheet(s) or repair help wanted. 0642
583075.

**OP37. Very low noise high performance
op-amp.** The ultimate device for high quality
audio. £3.45. Data and application notes 75p.
P&P 25p. NCJ Electronics, 38 Murrayfield
Road, Hull. HU5 4DW.

**Wanted Interak-1 modular computer
system - complete working system preferred
for computer student.** Tel: Dave Hodgson
Mbro. 0642-828779.

CLASSIFIED COUPON

									£3.22
									£4.83
									£6.44
									£8.05
									£9.66
									£11.27

Rates are 20p per word plus 3p VAT (lineage, for semi-display advertisements contact our Ad. Dept.). All classified advertisements must be pre-paid. Please send your copy with the remittance (payable to Intra Press or payments by Visa or Access accepted) to: Practical Electronics Classified Dept., Intra House, 193 Uxbridge Road, London W12 9RA. Tel: 081-743-8888, Fax: 081-743-3062

By coincidence, the United Nations' scientific panel on global warming reported its findings on the greenhouse effect in the very same week that the International Radio Consultative Committee's plenary assembly failed to agree on a world standard for high-definition television.

Apart from the UN link there seems no obvious connection between enhanced atmospheric carbon dioxide and hdtv. The second appears trivial compared with the serious implications to mankind of the first. Yet in fact hdtv does epitomise the human activities which are adding more parts per million every year to the natural level of CO₂ in the atmosphere. It is a new technology which sooner or later will become a new contributor to industrial production.

Initially, compatible broadcasting systems like Eureka 95 (see February and March 1989 issues) will not result in any immediate increase in tv set manufacturing. That's the point of adopting an 'evolutionary' compatible

INDUSTRY



NOTEBOOK

shareholders of electronics companies are not fundamentally interested in the technology or social impact of new products. They are only concerned to the extent that successful new products, better mousetraps, will expand markets, keep the factories going and maintain sales and profits.

In contrast is the class of electronic applications which are very useful to us but not exploitable in a mass market. The products here are devices and systems used in science, medicine, education, industrial automation and so on. They are manufactured in small quantities by specialist firms, and nobody makes a fortune out of them. Some electronic automation systems I've seen are essentially one-off: each is designed for its particular plant and will work nowhere else.

It's in this area that electronics can be of direct help in environmental problems like the greenhouse effect. Take, for example, the monitoring of flue gases from boilers and other industrial installations. There are many physical principles by which you can measure,

GREENHOUSE ELECTRONICS

system. But obviously the whole purpose of the development is for viewers eventually to be able to enjoy the higher definition picture on new sets capable of displaying them.

The commercial motivation behind hdtv, justifying the r&d expenditure and manufacturing investment, is the boost it's likely to give to the television sector of the consumer electronics industry. In the past we have had shots in the arm from new transmission standards, colour, larger screens, teletext, remote controls, vcrs and, most recently, digital stereo sound. Arriving this year will be 16:9 wide-screen sets. Initially these will work on existing transmission standards, but they are also a practical step on the way towards hdtv reception and display.

At the time of writing the French industry minister has just announced a £2 billion collaboration between Philips and Thomson on hdtv development. The two firms have not yet confirmed it. But if they do get together it will make good sense. First of all Philips and Thomson have been major contributors to the development of the Eureka 95 system. Secondly, their alliance would form a stronger defence of the European consumer electronics industry against the undoubted willingness of the Japanese to manufacture hdtv sets for a European transmission standard.

You may think I'm being unreasonable in singling out hdtv as a 'culprit' in the worsening of the greenhouse effect. In fact the manufacture and use of motor cars will be responsible for a very much greater volume of CO₂ and other gas emissions into the atmosphere. I've merely picked on hdtv because it's a modern application of electronics and one which will probably have a wide market, initially as a luxury trade. As

By Tom Ivall

Electronics has two opposing ecological aspects, one adding to pollution, the other capable of monitoring its reduction. Both have to co-exist, but the latter must prevail.

individuals we could manage without it. Most people are still unaware of its potential existence and therefore don't feel particularly deprived without it.

When the broadcasters and set manufacturers eventually produce this new enhancement to home entertainment we shall, of course, be persuaded that we really do need it. And when the price of sets comes down, as it undoubtedly will, we shall no longer be worried by thoughts of extravagance and conspicuous consumption.

It will, however, be one more example of industrial production, commercial activity and economic growth driven forward by human craving and its satisfaction. The likely ecological disasters resulting from global warming will make the more thoughtful among us ask how much longer the industrialised countries can be allowed to continue on this path without restraint.

I've also picked on hdtv as representative of a particular class of electronic applications - as against another class which is relevant here. hdtv is an application which results in consumer products. These are simply grist to the mill of the electronics business. The

say, the carbon dioxide content of such gases. Some of these lend themselves to use in direct-reading instruments. One such instrument is the katharometer, another the mass spectrometer, a third the infra-red absorption analyser. All give electrical output signals which can be a/d converted, transmitted digitally and subsequently processed in computers.

Gas measuring instruments are an essential part of emission control systems. These are already being used on industrial plant to achieve more efficient burning of fossil fuels and so save energy and reduce emissions into the atmosphere. The electronic systems of motor cars would do well to include this principle rather than some of the trivial electronic gimmicks we are seeing at the moment.

With the aid of electronics the condition of the Earth's atmosphere is also being monitored from outside - by instruments carried in satellites. Most recent are five geostationary satellites strung out at roughly 70° intervals round the Earth. Some are European spacecraft (Meteosat) and others American (GOES Geostationary Operational Environmental Satellite).

As the names indicate, these satellites are partly for short-term weather forecasting and partly for longer-term environmental observations. In both types a radiometer working in the visible, infra-red and water-vapour wavelength regions measures the radiance of the Earth and its cloud cover. This instrument provides information - transmitted back to Earth as digital data which is being used to monitor both atmospheric pollution and water vapour concentration - another contributor to global warming.

PE



PRACTICAL ELECTRONICS BOOK SERVICE

Here is your Editor's choice of books he thinks will be of interest to electronics and computer enthusiasts



BEGINNERS AND EARLY STARTERS

Mini-Matrix Board Projects.
R.A.Penfold. 112 pages. £2.50. Order Code BP99

Shows a selection of 20 useful and interesting circuits that can be built on a mini-matrix board of 24 holes by 10 copper strips in size - an ideal book for early experimenters.

From Atoms to Amperes.
F.A.Wilson. 160 pages. £3.50.
Order Code BP254.

For the absolute beginner, clearly explaining the fundamentals behind the whole subject of electricity and electronics.

Electronic Projects for Beginners.
F.G.Rayer. 128 pages. £1.95.
Order Code BP48

Specially for the newcomer to electronics who is looking for a book containing a wide range of easily made projects. Some circuits need no soldering and many others show actual component and wiring layouts.

Electronics Build and Learn
R.A.Penfold. 128 Pages. £5.95. Order Code PC 101

Combining theory and practice, the book describes a circuit demonstrator unit that is used in subsequent chapters to introduce common electronic components and circuit concepts, complete with practical experiments.

Practical Electronic Building Blocks
R.A.Penfold. There are two books -
Book 1 : 128 pages. £1.95.
Order Code BP117
Book 2 : 112 pages. £1.95.
Order Code BP118

Book 1 is about oscillators and gives circuits for a wide range, including sine, triangle, square, sawtooth and pulse waveforms and numerous others from voltage controlled to customised IC types.

Book 2 looks at amplifiers, ranging from low level discrete and opamp types to IC power amps. A selection of mixers, filters and regulators is included.

30 Solderless Breadboard Projects
R.A.Penfold. Two books each of 160 pages. Book 1 : £2.95. Order Code BP107. Book 2 : £2.25. Order Code BP113.

Each project is designed for building on a Verobloc breadboard and is accompanied by a description, circuit and layout diagrams and relevant constructional notes. Many of the components are common to several projects. Book 1 covers linear devices, and Book 2 covers CMOS logic chips.

Beginners Guide to Building Electronic Projects
R.A.Penfold. 112 pages. £1.95. Order Code BP 227

Shows the complete beginner how to tackle the practical side of electronics and includes simple constructional projects.

SATELLITE TV

Satellite TV Installation Guide - 2nd edition John Breeds. £11.95. Order Code STV1

Full of vital information for any competent DIYer who wishes to install a satellite TV antenna and obtain optimum reception quality.

An Introduction to Satellite Television
F.A.Wilson. 112 pages. £5.95. Order Code BP195

Informative answers to many of the questions about this communications revolution. The information is presented on two levels, one aimed at the complete beginner, the other at professional engineers and serious amateur enthusiasts.

TEST AND MEASUREMENT

Getting the Most from Your Multimeter
R.A.Penfold. 112 pages. £2.95. Order Code BP239

There's more to what you can do with a meter than meets the casual eye. The book covers the basics of what you can do with analogue and digital meters and discusses component and circuit testing.

Test Equipment Construction
R.A. Penfold £2.95.
Order Code BP248

Describes in detail how to construct some simple and inexpensive, but extremely useful, pieces of test equipment.

Oscilloscopes 2nd Edition
I.Hickman. £12.95. Order Code NT3

Subtitled 'How to Use Them, How They Work' the book is illustrated with diagrams and photographs and is essential reading for any one who wants to know about scopes, from first principles to practical applications.

How to Get Your Electronic Projects Working.
R.A.Penfold. 96 pages. £2.50.
Order Code BP110.

Essential reading for anyone who wants first-time success in project assembly. Covers tracing mechanical faults as well as testing for failures of active and passive components of most types.

AUDIO AND MUSIC

Introducing Digital Audio
I.Sinclair. 112 pages. £5.95.
Order Code PC102

A non-mathematical introduction to the new digital technology, discussing the principles and methods involved in devices such as CD, DAT and sampling.

Electronic Music Projects
R.A.Penfold. 112 pages. £2.50. Order Code BP74

24 practical constructional projects covering fuzz, wah, sustain, reverb, phasing, tremolo etc. The text is split into four sections covering guitar, general, sound generation and accessory projects.

More Advanced Electronic Music Projects
R.A.Penfold. 96 pages. £2.95.
Order Code BP174

Complementing BP74 by covering more advanced and complex projects including flanging, chorus, ring modulation, plus a selection of drum, cymbal and gong circuits.

Computer Music Projects
R.A.Penfold. 112 pages. £2.95. Order Code BP173

Shows how home computers can produce electronic music and covers sequencing, analogue and MIDI interfacing, digital delay lines and sound generators.

Practical MIDI Handbook
R.A.Penfold. 160 pages. £5.95.
Order Code PC103

A practical how-to-do-it book for musicians and enthusiasts who want to exploit the capabilities of MIDI. Covers keyboards, drums, sequencers, effects, mixers, guitars, and computer music software.

MIDI Projects
R.A.Penfold. 112 pages. £2.95. Order Code BP182

Practical details of interfacing many popular home computers with MIDI systems, and also covering MIDI interfacing to analogue and percussion synths.

Electronic Synthesiser Construction.
R.A.Penfold. 112 pages. £2.95. Order Code BP185.

Even relative beginners should find the monophonic synthesiser described here within their capabilities if the book is thoroughly read. Individual aspects of the synth are dealt with separately and PCB designs are shown for the main modules.

DIGITAL AND COMPUTING

A Concise Introduction to MS-DOS.
N. Kantaris. 64 pages. £2.95.
Order Code BP232

A ready-reference guide for those who need a quick insight into the essential command functions of this operating system, but who don't have the time to learn it fully.

An Introduction to Computer Peripherals

R.A. and J.W. Penfold. 80 pages.
£2.50. Order Code BP170

Covers such items as monitors, printers, disc drives, cassettes, modems, etc. explaining what they are and how to use them with your computer and with each other.

Digital Logic Gates and Flip-Flops. Ian R. Sinclair. 192 pages. £8.95. Order Code PC 105

Intelligently looks at the basic building blocks of all digital circuits and is intended for enthusiasts, students and technicians who seek to establish a firm grasp of fundamental principles.

Introduction to 6800/6802 Microprocessor Systems

R.J. Simpson and T.J. Terrell. 238 pages. £10.95. Order Code NT9

The book covers systems hardware, programming concepts and practical experimental work that will assist in understanding the 6800/6802 microprocessor, with additional information on the 6802D5E evaluation system.

An Introduction to 68000 Assembly Language.

R.A. and J.W. Penfold. 112 pages.
£2.95. Order Code BP184

Covers the fundamentals of writing programs that will vastly increase the speed of 68000 based machines such as the Commodore Amiga, Atari ST range, Apple Macintosh, etc.

Getting the Most from Your Printer
J.W. Penfold. 96 pages. £2.95.
Order Code BP181

How to use the features found on most dot-matrix printers from programs and popular wordprocessors, showing examples of what must be typed to achieve a given effect.

Micro Interfacing Circuits

R.A. Penfold. Two books, each of 112 pages.

Book 1 : £2.25. Order Code BP130.

Book 2 : £2.75. Order Code BP131

Both books include practical circuits and useful background information though pcb layouts are not included. Book 1 mainly covers computer input-output techniques. Book 2 deals primarily with practical application circuits.

An Introduction to 6502 Machine Code.

R.A. and R.W. Penfold. 112 pages.
£2.95. Order Code BP147

Covers the main principles of machine code programming on 6502-based machines such as the Vic-20, Oric-1/Atmos, Electron, BBC and Commodore 64. It assumes no previous knowledge of microprocessors or machine code and gives illustrative programming examples.

A Z-80 Workshop Manual.

E.A. Parr. 192 pages. £3.95.
Order Code BP112

A book for those who already know Basic but wish to explore machine code and assembly language programming on Z80 based computers.

Practical Digital Electronics Handbook

M. Tooley. 208 pages. £6.95.
Order Code PC 104

Nine constructional projects introduce digital circuits, logic gates, timers, microprocessors, memory and interface circuits - an essential book for anyone interested in digital devices.

DATA AND INFORMATION BOOKS

NEW! Radio and Electronics Engineer's Pocket Book - 18th Edition. Keith Brindley. 325 pages. £9.95. Order Code NT 11

An invaluable compendium of facts, figures and formulae and is indispensable to the designer, student, service engineer and all others interested in radio and electronics.

NEW! Microprocessor Pocket Book. Steve Money. 252 pages. £9.95. Order Code NT 12

Provides a wide selection of information which will be of general use to anyone involved in developing, designing or servicing, or who just wants to learn more about microprocessor systems.

NEW! Computer Engineer's Pocket Book - 2nd Edition. Michael Tooley. 224 pages. £9.95. Order Code NT 13

An invaluable compendium of facts, figures, circuits and data indispensable to designers, students, service engineers and all others interested in computer and microcomputer systems.

Op Amps

B. Dance. £7.95.

Order Code NT2

Subtitled 'Their Principles and Applications' this interesting book is written in a simple non-mathematical style and provides a source of practical circuits that use both commonplace and more sophisticated opamps.

Electronic Hobbyists Handbook

R.A. Penfold. 96 pages. £4.95. Order Code BP233

Provides a source of useful information that the amateur enthusiast is likely to need for day-to-day pursuance of hobby electronics.

Newnes Electronics Pocket Book

I.E. Parr. £9.95.

Order Code NT10

Presents all aspects of modern electronics in a readable and largely non-mathematical style, and is a good source of valuable information for enthusiasts and professional engineers alike.

Key Techniques for Circuit Design

G.C. Loveday. £6.95.

Order Code BM 101

Tackles the problems of designing circuits from scratch, introducing the concept of target specifications, the design sequence, device selection, rules of thumb, and useful equivalent circuits.



GENERAL CONSTRUCTIONAL

Electronic Science Projects.

Owen Bishop. 144 pages. £2.95. Order Code BP104

A bumper bundle of experimental projects ranging in complexity and including a colour temperature meter, electronic clock, a solid state (led display) scope, an infra-red laser, a fascinating circuit for measuring the earth's electrical field strength, and many more.

Electronic Security Devices

R.A. Penfold. 112 pages. £2.50. BP56

Full of ideas for keeping your valuables safe. The circuits include designs for light, infra-red, ultrasonic, gas, smoke, flood, door and baby sensors.

More Advanced Electronic Security Projects. R.A. Penfold. 112 pages. £2.95. Order Code BP190

Follows on from where BP56 leaves off and describes a number of more up-to-date and sophisticated projects, such as pyro-sensors, infra-red and doppler-shift detection, fibre-optic loops, and many others.

Electronic Projects for Cars and Boats.

R.A. Penfold. 96 pages. £1.95.

Order Code BP94

15 fairly simple projects that can be used with a car and/or boat. Stripboard constructional details are included, as are explanations of the circuit theory.

Power Supply Projects

R.A. Penfold. 96 pages. £2.50.

Order Code BP76

A selection of power supply designs, including simple unregulated, fixed voltage regulated and variable voltage stabilised, ni-cad charger, voltage step-up, and inverter.

More Advanced Power Supply Projects

R.A. Penfold. 96 pages. £2.95.

Order Code BP192

Covers more advanced topics than BP76 and includes precision supplies, switch mode and computer controlled supplies, plus a selection of miscellaneous circuits.

Popular Electronic Circuits.

R.A. Penfold. 160 pages. £2.95. Order Code BP80

Containing a wide range of circuit designs for experienced constructors who are capable of producing working projects direct from a circuit diagram without specific constructional details.

HOW TO ORDER

State your order code and your name and address clearly. Enclose a cheque, PO or international money order (add 50p postage per book - £1.00 for overseas surface mail), and send to:

PE Book Service

Intra House

193 Uxbridge Road

London W12 9RA

Books are normally delivered within 10 days but please allow 28 days for delivery.

PE PCB SERVICE

IT IS EASY TO BUILD PRACTICAL ELECTRONICS PROJECTS!

Simplify your project assembly - use a ready-made printed circuit board. All are fully drilled and roller tinned. Just slot in the components as shown in the project texts, and solder them. PCBs are the professional route to project perfection.

MAIL ORDERING

Select the boards you want, and send your order to: PE PCB SERVICE, PRACTICAL ELECTRONICS, 193 UXBRIDGE ROAD, LONDON W12 9RA.

Prices include VAT and postage and packing. Add £2 per board for overseas airmail. Cheques should be made payable to Intra Press (Payments by Access and Visa also accepted). Quote the project name and PCB Code Number, and print your name and address in Block Capitals. Do not send any other correspondence with your order.

TELEPHONE ORDERS

Use your Access or Visa card and phone your order to **081-743-8888** clearly stating your name and address, card number and order details. All orders receive priority attention. Many PCBs are held in stock, so they are dispatched within a few days, but please still allow 28 days for delivery in case a PCB is temporarily out of stock.

We can only supply the PCBs listed here! Please always check the latest issue of PE before ordering.

We can also supply the photocopies of the text at £1.50 for each project part inclusive of postage and packing (overseas £2.00).

Please note that we do not supply components - they can be ordered from our advertisers!

NOV 87	MIDI EXPANDER - Music Interface	159	£5.04
DEC 87	RS 232C TO MIDI	160	£6.43
FEB 88	DC MOTOR SERVO	165	£7.53
MAR 88	APPLIANCE TIMER	166A/B	£9.38
	LOGIC ANALYSER - Double-sided	168	£20.65
APR 88	LIGHT METAL EFFECTS	169	£7.10
JUNE 88	AMSTRAD ROM EXPANSION	173	£12.60
	MAINS MODEM	174	£4.90
JULY 88	VOCALS ELIMINATOR	175	£4.90
AUG 88	SPEAKING CLOCK	176	£16.75
SEPT 88	BBC MULTIPLEXER	177	£4.50
OCT 88	METAL DETECTOR	178	£6.50
DEC 88	PANNING MIXER	181	£7.80
MAR 89	CAMERA SHUTTER TIMER	187	£9.95
APR 89	PC MULTIPOINT	188A/B	£20.55
MAY 89	KIRLIAN CAMERA	189A/C	£10.50
JUNE 89	DELUXE METRONOME	198	£10.95

JULY 89

PROJECTOR SYNCHRONISER 190A £9.50

AUG 89

HAND CLAPPER 192 £6.50

SEP 89

EASI-BUILD - COMPRESSOR 193 £5.90

FREQUENCY COUNTER-GENERATOR 194A/B £12.50

OCT 89

EASI-BUILD VOICE-OP-SWITCH 195 £5.90

HOME SECURITY CONTROLLER 196A/C £19.50

DEC 89

VIDEO AGC STABILISER 199 £6.50

ECHO STATION 200A/B £11.50

MINI METRONOME 201 £5.90

JAN 90

BARGRAPH TACHOMETER 202 £5.90

EEPROM PROGRAMMER (KEYBOARD VER) 203 £14.50

FEB 90

EEPROM PROGRAMMER (SWITCH VERSION) 204 £4.90

MODEM 205 £11.50

MOCK STEREO 206 £4.90

MAR 90

RADIO CLOCK (TUNER AND PULSE) 207 £6.50

APR 90

RADIO CLOCK (DISPLAY DECODER) 208 £13.50

PC/INTERFACE 209 £5.90

MAY 90

EPROM POLY-PROG (MAIN PCB) 210 £8.50

JUNE 90

EPROM POLY-PROG (TOP PCB) 211 £7.50

MESSAGE MAKER 212 £9.50

BAUD RATE CONVERTER 213 £4.90

INTERMITTENT WIPER 214 £3.90

CIRCUIT BREAKER 215 £4.90

JULY 90

MORSE DECODER 216 £9.50

AUG 90

SCOPE EXPANDER 217 £9.50

VOLTAGE PROBE 218 £5.80

AF OCTAVE MEASURER:

FILTER DRIVE 219 £6.60

ANALOGUE FILTER 220 £7.35

SEP 90

AF OCTAVE MEASURER 221 £7.35

AMPLIFIER 222 £7.35

SWITCHED FILTER 223 £7.35

TELE-SCOPE 224 £11.50

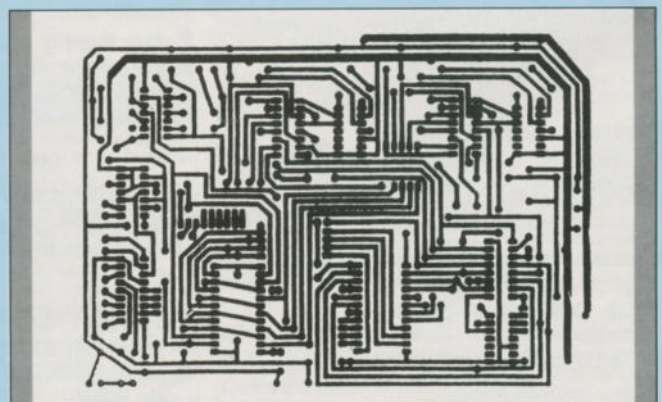

**PE PCBs are the professional route
to project perfection!**

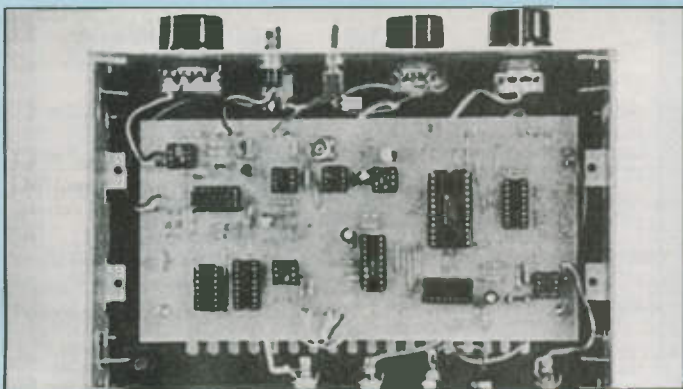

NICE AND EASY DOES IT

Building the projects published in PE is a lot easier than some of you perhaps might think. Especially when you use one of our professionally made printed circuit boards.

It's almost like painting by numbers. All the pcbs are fully drilled, and basically all you need to do is slot in the components and carefully solder them to the pcb track pads. Their places are shown in the drawings published with the project.

IDENTITIES

Component identities are usually clearly marked on them. Even if they are colour coded, like some resistors and capacitors, their values are easily worked out from component colour code charts. From time to time we publish these charts, but if you don't already have one, send a 9in x 4in stamped and self-addressed envelope to the Editorial office asking for one.

TOOLS

For many projects you only need a few simple tools - Soldering iron between 15W and 25W, with a bevelled tip. Damp sponge for keeping the tip clean. Good multicore solder of 18swg or 22swg grade. Fine nose pliers for wire shaping. Adjustable spanner or heavy pliers for tightening nuts. Miniature screwdriver for adjusting preset controls. Small wire cutters for trimming component leads. Drill and selection of bits for drilling holes in boxes. Strong magnifying glass for checking joins in close up. It's also preferable to have a multimeter for setting and checking voltages. There are some very good low cost ones available through many of our advertisers, but get one that is rated at a minimum of 20,000 ohms per volt. Many projects do not require you to have a meter, but if you are serious about electronics, you really should have one.

ASSEMBLING THE PCB

Authors will sometimes offer their own advice on the order of assembly, but as a general guide, it is usually easier to assemble parts in order of size. Start though with the integrated circuit sockets. Please use them where possible, they make life much easier than if you solder the ics themselves - with sockets you can just lift out an ic if you want.

Then insert and solder in order of resistors, diodes, presets, small capacitors, other capacitors, and finally transistors. Clip off the excess component leads after you have soldered them. Now use a magnifying glass, ideally one that you can hold to your eye, and take a good look at the joints, checking that they are satisfactorily soldered, and that no solder has spread between the pcb tracks and other joins. Be really thorough with visual checking since errors like this are the most likely reason for a circuit not working first time.

SOLDERING

Bring the tip of the iron into contact with the component lead and the pcb solder pad, then bring the end of the solder into contact with all three, feeding it in as it melts. Once sufficient solder has melted to fully surround the pad and the lead, remove the solder, and then the iron. Now allow the join to cool before touching it, otherwise the solder may set unsatisfactorily. If it does move, just reheat the join once more.

WIRING

Connecting the pcb to the various panel controls is the final assembly stage. Do this just as methodically, following the published wiring diagram. You can connect the wires to the pcb in one of three ways. The best is to insert terminal pins into the connecting holes on the pcb, and then solder wires direct to them. Or, pass the end of the wire through the pcb hole, soldering it on the other side. Alternatively, the wire can be carefully soldered direct to the pcb tracking. In all cases first strip the plastic covering off the wire, twist the strands together, and apply solder to them to keep them secure.

TESTING

Now you are ready to test and use the project as described by the author. Components can occasionally fail, but these days it is extremely uncommon, and if you have followed the instructions, been careful with your joins, and bought the parts from a good supplier, you will have the enormous satisfaction of having built an interesting and working unit. It really can be easy if you do it with care.

CHOOSE ONE NOW!

The PE PCB Service list shows all the pcbs available through PE. Look down the list and see which title takes your fancy - there must be at least one that will interest you! You will probably already have the relevant issue of PE, but even if you don't we can still help you.

BACK ISSUES

We can usually supply copies of back issues of PE up to three years old. These are £1.75 each including postage (£2.25 for overseas readers). If we no longer have the issue needed, we will be pleased to send a photocopy of the article for the project that you want to build. These are £1.00 each per issue, including postage (£1.50 to overseas readers).

OBTAINING PARTS

Some projects are available from advertising suppliers as complete kits. Otherwise, all the components listed in the text will be available from suppliers who specialise in individual components.

Occasionally a specific part may only be available from a particular supplier, if so the source will be given in the parts list. Otherwise there should be no difficulty in buying the parts. We have many good suppliers advertising in PE so have a look through their adverts - that's why they're here! Even though a part may not be listed in the adverts, a phone call or two should find a supplier who will be pleased to help. Like us, they too are in the business of encouraging you to enjoy electronics!

PE

VARIABLE VOLTAGE TRANSFORMERS

INPUT 220/240V AC 50/60 OUTPUT 0-280V
 200W 0.1 amp max £24.00 p&p £3.00 (E31.05 inc VAT)
 0.5KVA 2.5 amp max £28.50 £3.75 (E34.79 inc VAT)
 1KVA 5 amp max £34.00 £4.25 (E43.98 inc VAT)
 2KVA 10 amp max £49.00 £5.50 (E52.68 inc VAT)
 3KVA 15 amp max £65.00 £8.25 (E81.94 inc VAT)
 5KVA 25 amp max £115.00
 Carriage on request

VOLTAGE CHANGING TRANSFORMER
 1250 Watt auto. Tapped 0-90V, 100, 110, 115, 120, twice to obtain voltages between 90 and 240V Fitted in heavy duty louvered metal case. Fused input. Price incl VAT & p&p £39.50

FULL COMPREHENSIVE RANGE OF TRANSFORMERS-LT-INSULATION & AUTO (110-240V Auto transfer either case with American socket and mains lead or open frame type. Available for immediate delivery.

ULTRA VIOLET BLACK LIGHT FLUORESCENT TUBES
 4ft 40 watt £10.44 (£12.00 inc VAT) Ceiling only
 2ft 20 watt £7.44 + £1.25 p&p (£9.99 inc VAT)
 13in 10 watt £5.80 + 75p p&p (£7.53 inc VAT)
 12in 8 watt £4.80 + 75p p&p (£5.38 inc VAT)
 9in 8 watt £3.80 + 50p p&p (£5.12 inc VAT)
 6in 4 watt £3.00 + 50p p&p (£5.12 inc VAT)

230V AC BALLAST KIT for either 6ft, 9in or 12in tubes £5.50 + 55p p&p (£6.96 inc VAT)
 For 12in tubes £6.00 + 75p p&p (£7.75 inc VAT)

400 WATT UV LAMP
 Only £34.00 + £2.50 p&p (£41.98 inc VAT)

176 WATT BELF BALLASTED BLACK LIGHT MERCURY BULBS Available with BC or ES fitting. Price incl VAT & p&p £18.84.

12 VOLT BILGE PUMPS
 Buy direct from the importers
 500 QPH 18h head 3 amp £18.00 inc
 1750 QPH 18h head 9 amp £19.25 + £2.00 p&p (£25.00 inc VAT)

EPROM ERASURE KIT
 Build your own EPROM ERASURE for a fraction of the price of a make-up unit. Kit of parts less case includes 12in 8 watt 2537 Argon Tube Ballast unit pair of bi-pin leads neon indicator and 9 switch safety microswitch and cover £14.00 + £2.00 p&p (£18.40 inc VAT).

SUPER MY-LIGHT STROBE KIT
 Designed for Disco. Theoretical users etc. Approx 16 joules. Adjustable speed £48.00 + £2.00 p&p (£52.50 inc VAT)

Case and reflector £22.00 + £2.00 p&p (£27.80 inc VAT)
 SAE for further details including My-Light and industrial Strobe Kits

WIDE RANGE OF XENON FLASH TUBES
 Write/Phone your enquiries

EXTENSIVE RANGE OF DIFFERENT TYPES OF GEARED MOTORS AVAILABLE FROM STOCK

WASHING MACHINE WATER PUMP
 Brand new 240V AC fan cooled can be used for a variety of purposes. Inlets 1 1/2 inch. Outlet 1 inch. Price including p&p and VAT - £10.95 or 2 for £20 including p&p and VAT.

SPECIAL OFFER AC CAPACITORS

2 MFD 440V £2.50	5.4 MFD 440V £4.00
4.1 MFD 440V £3.50	5 MFD 440V £3.00
5 MFD 440V £4.00	12 MFD 400 £4.00

p + p 50p per unit plus VAT to be added to total.

TORN CENTRIFUGAL BLOWER
 230V ac 2,800 RPM 0.8amp 130mm diameter impeller outlet 63 x 37mm overall size 195 x 180 x 150mm long. Price £17.50 + £2.50 p&p (£23 inc VAT)

SHADED POLE GEAR MOTORS
 in the following sizes:
 9 RPM 12 RPM 80 RPM 180 RPM 110V AC or 240V AC with capacitors (supplied). Price incl VAT & p&p £12.85

GEARED MOTORS
 71 RPM 20in inch torque reversible 115V AC input including capacitor and transformer for 240V AC operation. Price incl VAT & p&p £23.00.

SOLID STATE SHT UNIT
 Input 230/240V AC. Output approx 15KV. Producing 10mm sparks. Built-in 10 sec timer. Easily modified for 20 sec, 30 sec to continuous. Designed for boiler ignition. Dozens of uses in the field of physics and electronics eg supplying neon or argon tubes etc. Price less case £8.50 + £1.00 p&p (£10.93 inc VAT) NMS

HEAVY DUTY MOTOR
 Croutal 115V/230V A.C. heavy duty 1RPM motor. Anticlockwise type £20.15. Size 68mm diameter x 55mm long. Shaft 6mm diameter x 20mm long. Price inc VAT & p&p £18.40

RHEOSTAT
 50W 2 ohm 5 amp ceramic power rheostat. Price inc VAT & p&p £10.35

MICROSWITCH
 Pys 15amp changeover lever microswitch, type S171. Brand new. Price 5 for £6.50 inc VAT & p&p.

12V DC 20 RPM reversible motor
 Swiss precision-built ideal for robotics. Length including shaft 90mm. Front fixing 38mm. Currently advertised by well known at £27.00 + P+P + VAT. Our price £14.95 incl. P+P and VAT.

NMS = NEW MANUF SURPLUS
 R&T = RECONDITIONED AND TESTED

SERVICE TRADING CO
 57 BRIDGMAN ROAD, CHISWICK, LONDON W4 5BB
 081-995 1560
 ACCOUNT CUSTOMERS MIN. ORDER £10

PROGRAMMABLE ELECTRONIC LOCK KIT

NEW

Keys could be a thing of the past with this new high security lock. Secure doors to sheds, garages, even your home or prevent the unauthorised use of computers, burglar alarms or cars. One 4-digit sequence will open the lock while incorrect entries will sound an alarm. The number of incorrect entries allowed before the alarm is triggered is selected by you. Further entries will be ignored for a time also set by you. Only the correct sequence will open the lock and switch off the alarm. The sequence may easily be changed by entering a special number and code on the supplied keyboard. Kit includes: keyboard, alarm buzzer, high quality PCB and all electronic components. Supply: 5 - 15V d.c. Will drive our Latch Mechanism (701 150 @ £16.50) or relay directly.

XK131 £17.35

DISCO LIGHTING KITS

DL8000K 8-way sequencer kit with built-in opto-isolated sound to light input. Only requires a box and control knob to complete. **£34.60**

DL1000K 4-way chaser features bi-directional sequence and dimming 1kW per channel. **£21.00**

DL21000K Uni-directional version of the above. Zero switching to reduce interference. **£11.80**

DLA/1 (for DL & DL21000K) Optional opto input allowing audio 'beat'/light response. **80p**

DL3000K 3-channel sound to light kit, zero voltage switching, automatic level control and built-in mic. 1kW per channel. **£17.00**

POWER STROBE KIT
 Produces an intense light pulse at a variable frequency of 1 to 15Hz. Includes high quality PCB, components, connectors, 5Ws strobe tube and assembly instructions. Supply 240V ac. Size: 80 x 50 x 45. **£15.00**

VERSATILE REMOTE CONTROL KIT

Includes all components (+transformer) for a sensitive IR receiver with 16 logic outputs (0 - 15V) which with suitable interface circuitry (relays, triacs etc - details supplied) can switch up to 16 items of equipment on or off remotely. Outputs may be latched to the last received code or momentary (on during transmission) by specifying the decoder IC and a 15V stabilised supply is available to power external circuits. Supply 240V AC or 15 - 24V DC at 10mA. Size (exc transformer) 9x4x2 cms. Companion transmitter is the MK18 which operates from a 9V PP3 battery and gives a range of up to 60ft. Two keyboards are available - MK9 (4-way) and MK10 (16-way). **£17.00** (inc transformer)

MK18 Transmitter **£7.80**
 MK9 4-way Keyboard **£2.40**
 MK10 16-way Keyboard **£7.00**
 601133 Box for Transmitter **£2.60**

VOICE RECORD/PLAYBACK KIT

This simple to construct and even simpler to operate kit will record and playback short messages or tunes. It has many uses - seatbelt or lights reminder in the car, welcome messages to visitors at home or at work, warning messages in factories and public places, in fact anywhere where a spoken message is announced and which needs to be changed from time to time. Also suitable for toys - why not convert your daughter's £8 doll to an £80 talking doll!!

Size 76 x 60 x 15mm
 Message time 1 - 5 secs normal speed, 2 - 10 secs slow speed

XK129 £22.50

INDEX TO ADVERTISERS

A & G Electronics Ltd.....29	J&N Bull Electrical.....38
ADM Electronics.....55	JPG Electronics.....55
Astra Training Services Ltd.....54	Keytronics.....11
Astronomy Now.....47	Lab Center Electronics.....22
N.R. Bardwell.....55	London Electronics College.....54
BK Electronics.....63	Maplin Electronics.....OBC
Bohm Organ.....34	Multilode Electronics.....22
Cambridge Computer Science..35	Nescot.....37
CERCO Training Ltd.....54	Number One Systems.....30
C.E.S. NW.....56	Omni Electronics.....54
Cirkit Distribution Ltd.....29	Phonosonics.....37
Cricklewood Electronics Ltd.....34	Radio & Telecom School.....54
C.R. Supply.....54	R. Scott.....55
Coles-Harding & Co.....55	Sarm Digital.....56
Component Solutions Ltd.....54	Service Trading.....62
Cooke International.....55	Stewart of Reading.....43
Dave Tronics Ltd.....29	Suma Designs.....22
Edward Arnold.....43	Tandy.....IFC
Fraser Electronics.....54	Technomatic Ltd.....18
Greenbank Electronics.....37	The Electronics Shop.....54
Happy Memories.....34	A. Wood (Northwest).....55
High Q Electronics.....56	Zeta Services.....56

PLEASE MENTION PRACTICAL ELECTRONICS WHEN REPLYING TO ADVERTS

TH ELECTRONICS

13 BOSTON RD. LONDON W7 3SJ
 TEL: 01-567 8910.
 FAX: 01-566 1916

ORDERING INFORMATION:
 All prices exclude VAT. Free P & P on orders over £50 (UK only), otherwise add £1 + VAT. Overseas P & P: Europe £3.50. Elsewhere £10. Send cheque/PO/Visa/Access No. with order. Giro No. 529314002
LOCAL AUTHORITY AND EXPORT ORDERS WELCOME
 GOODS BY RETURN SUBJECT TO AVAILABILITY



POWER AMPLIFIER MODULES-TURNABLES-DIMMERS-LOUDSPEAKERS-19 INCH STEREO RACK AMPLIFIERS

OMP POWER AMPLIFIER MODULES

Supplied ready built and tested.

OMP POWER AMPLIFIER MODULES Now enjoy a world wide reputation for quality reliability and performance at a realistic price. Four models available to suit the needs of the professional and hobby market i.e. Industry Lesure. Instrumental and Hi-Fi etc. When comparing prices NOTE all models include Toroidal power supply. Integral heat sink. Glass fibre P.C.B. and Drive circuits to power compatible Vu meter. Open and short circuit proof.

THOUSANDS OF MODULES PURCHASED BY PROFESSIONAL USERS



OMP100 Mk 11 Bi-Polar Output power 110 watts R.M.S. into 4 ohms. Frequency Response 15Hz - 30KHz - 3dB. T.H.D. 0.01% S.N.R. -118dB. Sens for Max output 500mV at 10K. Size 355 x 115 x 65mm. PRICE £33.99 + £3.00 P&P.

NEW SERIES II MOS-FET MODULES



OMP/MF 100 Mos-Fet Output power 110 watts R.M.S. into 4 ohms. Frequency Response 1Hz - 100KHz - 3dB. Damping Factor >300. Slew Rate 45V uS. T.H.D. Typical 0.002%. Input Sensitivity 500mV. S.N.R. -125dB. Size 300 x 123 x 60mm. PRICE £39.99 + £3.00 P&P.



OMP/MF200 Mos-Fet Output power 200 watts R.M.S. into 4 ohms. Frequency Response 1Hz - 100KHz - 3dB. Damping Factor >300. Slew Rate 50V uS. T.H.D. Typical 0.001%. Input Sensitivity 500mV. S.N.R. -130dB. Size 300 x 155 x 100mm. PRICE £62.99 + £3.50 P&P.



OMP/MF300 Mos-Fet Output power 300 watts R.M.S. into 4 ohms. Frequency Response 1Hz - 100KHz - 3dB. Damping Factor >300. Slew Rate 60V uS. T.H.D. Typical 0.0008%. Input Sensitivity 500mV. S.N.R. -130dB. Size 330 x 175 x 100mm. PRICE £79.99 + £4.50 P&P.

NOTE - MOS-FET MODULES ARE AVAILABLE IN TWO VERSIONS. STANDARD INPUT SENS 500mV BAND WIDTH 100KHz. PEC PROFESSIONAL EQUIPMENT COMPATIBLE. INPUT SENS 75mV BAND WIDTH 50KHz. ORDER STANDARD OR PEC.



Vu METER Compatible with our four amplifiers detailed above. A very accurate visual display employing 11 LED diodes (7 green, 4 red) plus an additional on off indicator. Sophisticated logic control circuits for very fast rise and decay times. Tough moulded plastic case with tinted acrylic front. Size 84 x 27 x 45mm. PRICE £8.50 + 50p P&P.

LOUDSPEAKERS



LARGE SELECTION OF SPECIALIST LOUDSPEAKERS AVAILABLE, INCLUDING CABINET FITTINGS, SPEAKER GRILLES, CROSS-OVERS AND HIGH POWER, HIGH FREQUENCY BULLETS AND HORNS, LARGE S.A.E. (30p STAMPED) FOR COMPLETE LIST.

McKENZIE:- INSTRUMENTS, P.A., DISCO, ETC.

- ALL McKENZIE UNITS 8 OHMS IMPEDANCE
- 8" 100 WATT C8100GPM GEN PURPOSE LEAD GUITAR EXCELLENT MID DISCO RES FREQ 80Hz FREQ RESP TO 14KHz SENS 99dB PRICE £28.59 + £2.00 P&P.
- 10" 100 WATT C10100GP GUITAR VOICE ORGAN KEYBOARD DISCO EXCELLENT MID RES FREQ 70Hz FREQ RESP TO 6KHz SENS 100dB PRICE £34.70 + £2.50 P&P.
- 10" 200 WATT C10200GP GUITAR KEYBOARD DISCO EXCELLENT HIGH POWER MID RES FREQ 45Hz FREQ RESP TO 7KHz SENS 100dB PRICE £37.48 + £2.50 P&P.
- 12" 100 WATT C12100GP HIGH POWER GEN PURPOSE LEAD GUITAR DISCO RES FREQ 45Hz FREQ RESP TO 7KHz SENS 98dB PRICE £36.66 + £3.50 P&P.
- 12" 100 WATT C12100TC TWIN CONE HIGH POWER WIDE RESPONSE P.A. VOICE DISCO RES FREQ 40Hz FREQ RESP TO 14KHz SENS 100dB PRICE £37.63 + £3.50 P&P.
- 12" 200 WATT C12200B HIGH POWER BASS KEYBOARDS DISCO P.A. RES FREQ 40Hz FREQ RESP TO 7KHz SENS 100dB PRICE £64.17 + £3.50 P&P.
- 12" 300 WATT C12300GP HIGH POWER BASS LEAD GUITAR KEYBOARDS DISCO ETC RES FREQ 45Hz FREQ RESP TO 5KHz SENS 100dB PRICE £85.79 + £3.50 P&P.
- 15" 100 WATT C15100BS BASS GUITAR LOW FREQUENCY P.A. DISCO RES FREQ 40Hz FREQ RESP TO 5KHz SENS 98dB PRICE £53.70 + £4.00 P&P.
- 15" 200 WATT C15200BS VERY HIGH POWER BASS RES FREQ 40Hz FREQ RESP TO 4KHz SENS 99dB PRICE £73.26 + £4.00 P&P.
- 15" 250 WATT C15250BS VERY HIGH POWER BASS RES FREQ 40Hz FREQ RESP TO 4KHz SENS 99dB PRICE £80.53 + £4.50 P&P.
- 15" 400 WATT C15400BS VERY HIGH POWER LOW FREQUENCY BASS RES FREQ 40Hz FREQ RESP TO 4KHz SENS 102dB PRICE £94.12 + £4.50 P&P.
- 18" 400 WATT C18400BS EXTREMELY HIGH POWER LOW FREQUENCY BASS RES FREQ 27Hz FREQ RESP TO 3KHz SENS 99dB PRICE £167.85 + £5.00 P&P.

EARBENDERS:- HI-FI, STUDIO, IN-CAR, ETC.

- ALL EARBENDER UNITS 8 OHMS EXCEPT EB8-50 AND EB10-50 DUAL 4 AND 8 OHM. BASS, SINGLE CONE, HIGH COMPLIANCE, ROLLED FOAM SURROUND
- 8" 50 WATT EB8-50 DUAL IMPEDANCE, TAPPED 4 8 OHM BASS HI-FI, IN-CAR RES FREQ 40Hz FREQ RESP TO 7KHz SENS 97dB PRICE £8.90 + £2.00 P&P.
- 10" 50 WATT EB10-50 DUAL IMPEDANCE, TAPPED 4 8 OHM BASS HI-FI, IN-CAR RES FREQ 40Hz FREQ RESP TO 5KHz SENS 99dB PRICE £12.00 + £2.50 P&P.
- 10" 100 WATT EB10-100 BASS HI-FI STUDIO RES FREQ 35Hz FREQ RESP TO 3KHz SENS 96dB PRICE £27.50 + £3.50 P&P.
- 12" 60 WATT EB12-60 BASS HI-FI STUDIO RES FREQ 28Hz FREQ RESP TO 3KHz SENS 92dB PRICE £21.00 + £3.00 P&P.
- 12" 100 WATT EB12-100 BASS STUDIO HI-FI, EXCELLENT DISCO RES FREQ 26Hz FREQ RESP TO 3KHz SENS 93dB PRICE £32.00 + £3.50 P&P.
- FULL RANGE TWIN CONE, HIGH COMPLIANCE, ROLLED SURROUND
- 5 1/2" 60 WATT EB5-60TC (TWIN CONE) HI-FI MULTI-ARRAY DISCO ETC RES FREQ 63Hz FREQ RESP TO 20KHz SENS 92dB PRICE £9.99 + £1.50 P&P.
- 6 1/2" 60 WATT EB6-60TC (TWIN CONE) HI-FI MULTI-ARRAY DISCO ETC RES FREQ 38Hz FREQ RESP TO 20KHz SENS 94dB PRICE £10.99 + £1.50 P&P.
- 8" 60 WATT EB8-60TC (TWIN CONE) HI-FI MULTI-ARRAY DISCO ETC RES FREQ 40Hz FREQ RESP TO 18KHz SENS 89dB PRICE £12.99 + £1.50 P&P.
- 10" 60 WATT EB10-60TC (TWIN CONE) HI-FI MULTI-ARRAY DISCO ETC RES FREQ 35Hz FREQ RESP TO 12KHz SENS 86dB PRICE £16.49 + £2.00 P&P.

TRANSMITTER HOBBY KITS

PROVEN TRANSMITTER DESIGNS INCLUDING GLASS FIBRE PRINTED CIRCUIT BOARD AND HIGH QUALITY COMPONENTS COMPLETE WITH CIRCUIT AND INSTRUCTIONS



3 watt FM Transmitter

3W FM TRANSMITTER 80-108MHz VARICAP CONTROLLED PROFESSIONAL PERFORMANCE RANGE UP TO 3 MILES SIZE 38 x 123mm SUPPLY 12V 0.5AMP PRICE £14.49 + £1.00 P&P

FM MICRO TRANSMITTER BUG 100-108MHz VARICAP TUNED COMPLETE WITH VERY SENS FET MIC RANGE 100-300m SIZE 56 x 46mm SUPPLY 9V BATT PRICE £8.62 + £1.00 P&P

* PRICES INCLUDE V.A.T. * PROMPT DELIVERIES * FRIENDLY SERVICE * LARGE S.A.E., 30p STAMPED FOR CURRENT LIST.

OMP VARISPEED TURNTABLE CHASSIS



- ★ MANUAL ARM
- ★ STEEL CHASSIS
- ★ ELECTRONIC SPEED CONTROL 33 & 45
- ★ VARI PITCH CONTROL
- ★ HIGH TORQUE SERVO DRIVEN DC MOTOR
- ★ TRANSISTOR SCREWS
- ★ 12 DIE CAST PLATTER
- ★ NEON STROBE
- ★ CALIBRATED BAL WEIGHT
- ★ REMOVABLE HEAD SHELL
- ★ CARTRIDGE FIXINGS
- ★ CUE LEVER
- ★ POWER 220 240V 50/60Hz
- ★ 390-305mm
- ★ SUPPLIED WITH MOUNTING CUMMOT TEMPLATE

PRICE £59.99 + £3.50 P&P.

OPTIONAL MAGNETIC CARTRIDGES

STANTON AL500 PRICE £16.99 + 50p P&P

GOLDRING G850 PRICE £6.99 + 50p P&P

OMP MOS-FET POWER AMPLIFIERS, HIGH POWER, TWO CHANNEL 19 INCH RACK

THOUSANDS PURCHASED BY PROFESSIONAL USERS



NEW MXF SERIES OF POWER AMPLIFIERS

THREE MODELS:- MXF200 (100w + 100w) MXF400 (200w + 200w) MXF600 (300w + 300w)

All power ratings R.M.S. into 4 ohms

FEATURES: ★ Independent power supplies with two Toroidal Transformers ★ Twin L.E.D. Vu meters ★ Rotary indexed level controls ★ Illuminated on off switch ★ XLR connectors ★ Standard 775mV inputs ★ Open and short circuit proof ★ Latest Mos-Fets for stress free power delivery into virtually any load ★ High slew rate ★ Very low distortion ★ Aluminium cases ★ MXF600 Fan Cooled with D.C. Loudspeaker and Thermal Protection

USED THE WORLD OVER IN CLUBS, PUBS, CINEMAS, DISCOS ETC.

- SIZES:- MXF 200 W19 - H3 1/2 (2U) - D11
- MXF 400 W19 - H5 1/4 (3U) - D12
- MXF 600 W19 - H5 1/4 (3U) - D13

MXF200 £171.35
MXF400 £228.85
MXF600 £322.00

SECURICOR DELIVERY £12.00 EACH

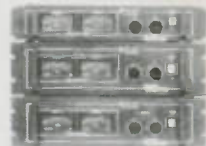

OMP LINNET LOUDSPEAKERS

THE VERY BEST IN QUALITY AND VALUE



MADE ESPECIALLY TO SUIT TODAY'S NEED FOR COMPACTNESS WITH HIGH OUTPUT SOUND LEVELS FINISHED IN HARDWEARING BLACK VINYLIDE WITH PROTECTIVE CORNERS GRILLE AND CARRYING HANDLE INCORPORATES 12 DRIVER PLUS HIGH FREQ HORN FOR FULL FREQ RANGE 45Hz-20KHz BOTH MODELS 8 OHM SIZE H18 - W15 - D12

CHOICE OF TWO MODELS

POWER RATINGS QUOTED IN WATTS RMS FOR EACH CABINET

OMP 12-100 (100W 100dB) PRICE £159.99 PER PAIR

OMP 12-200 (200W 102dB) PRICE £209.99 PER PAIR

SECURICOR DEL:- £12.00 PER PAIR

OMP SLIDE DIMMER 1K WATT & 2.5K WATT

CONTROLS 5 LOADS UP TO 1KW & 2.5KW BUT ALSO FOR RESISTIVE AND INDUCTIVE LOADS BLACK ANODISED CASE REARLY FLUSH MOUNTED THROUGH PANEL CABINET CUT-OUTS ADVANCED FEATURES INCLUDE:-

- Full 1/85mm SLIDE TRAVEL
- NFON MONITOR INDICATOR
- FLASH OVERRIDE BUTTON
- HIGH & LOW LEVEL PRESETS
- FULLY SUPPRESSED TO BS 880

SIZES: 1KW H128 - W40 - D56mm 2.5KW H128 - W70 - D73mm

PRICES - 1K WATT £15.99 2.5K WATT £24.99 + 60p P&P

PIEZO ELECTRIC TWEETERS-MOTOROLA

PIEZO ELECTRIC TWEETERS - MOTOROLA

Join the Piezo revolution. The low dynamic mass (no voice coil) of a Piezo tweeter produces an improved transient response with a lower distortion level than ordinary dynamic tweeters. As a crossover is not required these units can be added to existing speaker systems of up to 100 watts (more if 2 put in series). FREE EXPLANATORY LEAFLETS SUPPLIED WITH EACH TWEETER.



TYPE 'A' (KSN2036A) 3 round with protective wire mesh ideal for bookshelf and medium sized Hi-Fi speakers. Price £4.90 each + 50p P&P

TYPE 'B' (KSN1005A) 3" super horn. For general purpose speakers disco and P.A. systems etc. Price £5.00 each + 50p P&P

TYPE 'C' (KSN6016A) 2" 5 wide dispersion horn. For quality Hi-Fi systems and quality discos etc. Price £6.99 each + 50p P&P

TYPE 'D' (KSN1025A) 2" 6 wide dispersion horn. Upper frequency response retained extending down to mid range (2KHz). Suitable for high quality Hi-Fi systems and quality discos. Price £9.99 each + 50p P&P

TYPE 'E' (KSN1038A) 3" horn tweeter with attractive silver finish trim. Suitable for Hi-Fi monitor systems etc. Price £5.99 each + 50p P&P

LEVEL CONTROL Combines on a recessed mounting plate level control and cabinet input jack socket 85 x 85mm. Price £3.99 + 50p P&P

STEREO DISCO MIXER

STEREO DISCO MIXER with 2 x 5 band L & R graphic equalisers and twin 10 segment L.E.D. Vu Meters. Many outstanding features 5 inputs with individual faders providing a useful combination of the following - 3 Turntables (Mag) 3 Mics 4 Line including CD plus Mic with talk over switch Headphone Monitor Pan Pot L & R Master Output controls Output 775mV Size 360 x 280 x 90mm Supply 220-240V

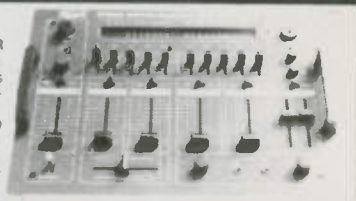

Price £134.99 - £4.00 P&P

B. K. ELECTRONICS Dept PE
UNIT 5, COMET WAY, SOUTHEND-ON-SEA, ESSEX. SS2 6TR
TEL: 0702-527572 FAX: 0702-420243



POSTAL CHARGES PER ORDER £1.00 MINIMUM OFFICIAL ORDERS WELCOME FROM SCHOOLS COLLEGES GOVT BODIES ETC. PRICES INCLUSIVE OF V.A.T. SALES COUNTER VISA ACCESS ACCEPTED BY POST PHONE OR FAX



1991 BUYER'S GUIDE TO ELECTRONIC COMPONENTS

Maplin

FEATURING:
AN ELECTRONICS
CAST OF
THOUSANDS!

COMING
to your local WHSMITH from
7th SEPT

**POWER-PACKED
WITH OVER
600 PAGES!!**

**STARRING
HUNDREDS OF
NEW PRODUCTS
AT SUPER
LOW PRICES!**



ROD BROWN

Order you copy of the New MAPLIN Catalogue on sale September
Pick up a copy from any WHSMITH for just £2.45 or post this coupon now to receive your
copy for just £2.45 + 50p p&p. If you live outside the U.K. send £4.85 or
20 International Reply Coupons. I enclose £2.95.

Name _____
Address _____
Post Code _____
Send to Maplin Electronics
P.O. Box 3, Rayleigh,
Essex S50 8LR.

PERFORMANCES DAILY
At your local branch
of WHSMITH
ONLY £2.45



PE91