

PRACTICAL

DECEMBER 1989 • £1.25

ELECTRONICS

SCIENCE AND TECHNOLOGY

**VIDEO AGC
STABILISER**

**Build a Video Signal
Cleaner Interface**

**MINI
METRONOME**
**Be Flashy With Our
Easy Metre-Beater!**

**ECHO
STATION**
**Join The Chorus Line
With Multistaged
Polyphony**

HF RADIO
**Understand RF/IF
Filters And Detectors**

**THERMAL
VOLTMETER**
**Put Power
Monitoring On The
Hot-Line!**

**PLUS:
ANNUAL
INDEX 1989!**

REALISTIC®

PORTABLE PROGRAMMABLE SCANNERS

10-CHANNEL PROGRAMMABLE SCANNER

- ▼ Covers: 68-88 MHz VHF-Lo, 136-174 MHz VHF-Hi And 406-512 MHz UHF
- ▼ Frequency Synthesized - No Crystals To Buy
- ▼ LCD Channel Display
- ▼ Direct Entry Keyboard
- ▼ Manual And Scan Modes
- ▼ 1/8" Jack For Earphone

20-9139



£249.95



20-9135

200-CHANNEL PROGRAMMABLE SCANNER

- ▲ Covers: 68-88, 108-136 MHz (AM), 136.005-174, 380-512 And 806-960 MHz
- ▲ Frequency Synthesized - No Crystals To Buy
- ▲ Lockout Key Temporarily Bypasses Unwanted Channels
- ▲ Two Speed Scan And Search
- ▲ LCD Display And Switchable Backlight
- ▲ 1/8" Earphone Jack And BNC Jack For External Aerial

Tandy®

Tune into Tandy TODAY

Over 400 Stores And Dealers Nationwide Prices may vary at Dealers. Offers subject to availability.

Tandy, Tandy Centre, Leamore Lane, Walsall, West Midlands, WS2 7PS

PRACTICAL ELECTRONICS

VOL 25 NO 12

DECEMBER 1989

CONTENTS

COMPETITION RESULTS

MAPLINOSCOPY WINNERS!45

All is revealed - the winners and the answers to the competition with Maplin 20MHz oscilloscope as prizes!

CONSTRUCTIONAL PROJECTS

VIDEO AGC STABILISER by Robert Penfold12

Copy-protected video tapes may not satisfactorily play back on some video machines. Using an agc stabilising interface might help cure the problem.

MONO-STEREO ECHO STATION - PART TWO by John Becker .27

Taking up where we left off in Oct 89, we conclude the construction and setting-up of this very versatile audio effects modifier.

THERMAL CONVERSION VOLTMETER by Rod Cooper ..35

A companion to the true rms ammeter of June 89, this ingenious voltmeter is specifically designed for use in power electronics.

GATED TIMING by Andrew Armstrong38

As an answer to this month's Ask PE query, Andrew describes another way in which timing periods can be extended, using selectable digital gates.

MINI METRONOME by John Becker48

A flashy led and audio additive circuit doubly marks accented beats for musicians, and is this month's Easi-build project.

SPECIAL FEATURES

REPAIRING THE AL80 by Vivian Capel17

The manufacturers of the old-time favourite power amp may be obsolete, but the module needn't be!

HF RADIO - PART FIVE by Mike Sanders21

In the penultimate article in the series, special refinements to receivers are examined, including agc and squelch considerations.

A PARTY TO REMEMBER by John Becker30

The Party's over but the memories (and the hangovers?) linger on. Nostalgic reunions, spirited chats, a shining award, an odd-ode and a tour round the Steam Museum suitably commemorated our 25th Birthday.

UCT MEASUREMENTS - PART TWO by Anthony H. Smith ..41

Concluding the authoritative advice on how to get the best out of universal counter timer measurements.

REGULAR FEATURES

EDITORIAL by John Becker - Cop out9

LEADING EDGE by Barry Fox - Deaf video phones8

INDUSTRY NOTEBOOK by Tom Ivall - "Sorry, wrong person!"57

SPACEWATCH by Dr Patrick Moore - Neptune and Venus46

PRODUCT FEATURES

ANNUAL INDEX - January to December 198960

NEWS AND MARKETPLACE - what's new, where and when4

PCB SERVICE - professional PCBs for PE Projects44

BOOKMARK - Your Ed browses through some new books50

ARMCHAIR BOOKSHOP - haven for practical bookworms.....58

ADVERTISERS' INDEX - locating favourite stockists62

PE FURTHERS TECHNOLOGY'S FUTURE - BE PART OF IT!



Page 4 ▲

Page 27 ▼

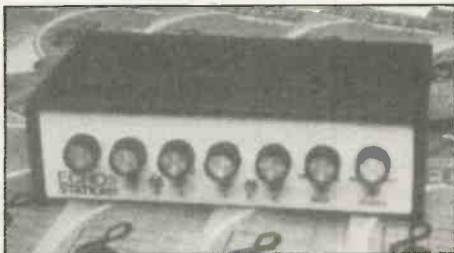

Page 30 ▼



NEXT MONTH

INTO THE NINETIES WITH PE!

We ring in Christmas and the New Decade with our bumper bundle of project ideas, including a keypad operated Eeprom Programmer that's far too good to miss. And, especially for the early starters, we begin a brand new series on Basic Electronics, telling you how and why electronics works! Plus, of course, our usual feast of other great features.

★ WELCOME THE NEW
DECADE WITH

OUR JANUARY 1990
ISSUE

★ ON SALE FROM FRIDAY
DECEMBER 1ST

★ YOU CAN'T BEAT OUR
VALUE

★ OR OUR CELEBRATED
OFFERINGS!



NEW AMSTRAD FAX FACTS

On display at the PC Show in September was a really elegant-looking personal fax machine from Amstrad, their FX9600T, selling at £599 plus vat.

One nice touch is that the machine has an in-build full function telephone handset allowing hands-free dialling as well as a 100-number library of commonly used fax and phone numbers. The sheet feeder takes up to 20 sheets at a time (if you've ever used as fax you'll know the advantage

of this facility), and there is a built-in cutter which automatically cuts the received sheets to their original lengths.

Alan Sugar, Amstrad's chairman is obviously proud of the last two features, saying, "We have looked carefully at fax machines already sold in this price sector and have noted that they failed to incorporate (these) two very important features. Our £600 machine includes them and many others that you could only expect to find on a model costing nearly twice as much."

The other key features that this fax incorporates are: CCITT Group 3 compatibility; user-friendly

interactive lcd display with 20 digits by two lines; local copying facility enabling desktop copying of originals; separate fax and phone autodialling allowing up to 50 fax numbers and a further 50 phone numbers to be stored; automatic redial; special 16-shade halftone feature ensuring clear transmissions of photos and graphics; standard built-in parallel port offering high quality Epson and IBM compatible printer option, and the sending of fax documents from a word processor without using paper. There is an additional feature that enables personal signatures to be scanned and stored in memory (can't help thinking, though, I wouldn't want mine stored like this for fear of fraudulent use).

For the business operator the machine offers a choice of using either BT or Mercury communication lines. Amstrad say this machine is the first fax to be Mercury compatible. Finally, the machine has a battery back-up, a paper-out alarm, and confirms that the transmission has been received.

"Personal computers are now a commonplace sight on people's desks and in their homes", observes Alan Sugar, "and I consider that before long the same will be true of our fax machine."

For further information on the FX9600T, contact Amstrad at 169 Kings Road, Brentwood, Essex, CM14 9BB. Tel: 01-240 2520.

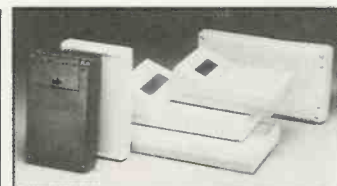

ANONYMOUS ENCLOSURE

OK Industries have dubbed their PacTec range 'the anonymous enclosures' because, says the managing director James Dornan, of their simple, gimmick-free, functional external design. Hundreds of thousands of these plastic boxes house hundreds of manufacturers' electronic circuits, but the brand remains anonymous.

The latest instrument enclosure kits, made from impact resistant abs in moulded-through colours, are simple both to 'design into' and assemble. Internally, moulded-in bosses, card guides and panel guides cut assembly time and production costs, and the cases can be supplied in kit and production quantities off-the-shelf. Eliminating tooling costs, the PacTec enclosures can, nevertheless, be customised with specific customer panel designs.

For further information contact: OK Industries UK Ltd., Barton Farm Industrial Estate, Chickenhall Lane, Eastleigh, Hants SO5 5RR. Tel: 0703 619841.

CATALOGUE

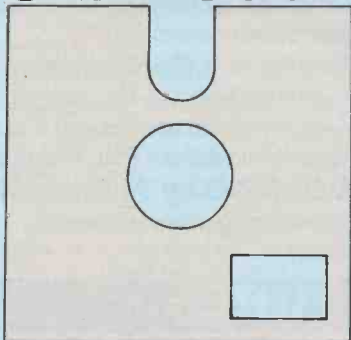

Continuing our alphabetical browse through advertisers' literature

Maplin have sent another copy of their catalogue. There's no doubt that this bumper cat, of over 500 pages, is a must for any electronics enthusiast, whether a raw beginner, or fully-fledged expert. From components, kits and pcbs to tools, test gear and transformers, plus masses more, this book covers the ranges. For this catalogue, contact Maplin Electronics, PO Box 3, Rayleigh, Essex, SS6 2BR. Tel: 0707 554161. Maplin also have a professional supplies division too. I can't altogether go along with the claim that the catalogue associated with this division is the 'Electronic Component Buyers Encyclopaedia' but it has a good range of products, from batteries through ics to xenon tubes. Maplin Professional Supplies are at PO Box 777, Rayleigh, Essex, SS6 8LU. Tel: 0707 552961.

What an amazing organisation Mauritron are! Over 20 A4 pages in which they highlight their stocks of service manuals, repair and data guides (even covering vintage wireless sets), and magazines. Many computing and electronic mag back issues are listed, including PE!

Mauritron also offer to do their best to obtain service manuals for unusual or obsolete pieces of equipment. They also publish the Mauritron Review which, they say, is a unique publication catering for anyone who ever uses, repairs or sells any electronic/electrical equipment. Other services are offered by this enterprising company as well. Mauritron Technical Services, 8 Cherry Tree Road, Chinnor, Oxon, OX9 4QY. Tel: 0844 51694.

Number One Systems say that their theme is to "make Computer Aided Design affordable". It is also apparent from the literature they've sent that they make cad easy as well. Among their many software packages they cover pcb design (including one specifically for hobbyists), pen and photo plotting, a schematic symbol library for 7400 ttl series, several versions of ac linear circuit analysis, and a text processor for programmers. Additionally, they have a range of hardware, including pen plotters and pens. They also have the Q.A.Robot, a fully automatic, computer controlled, non-contact, optical inspection system for industrial applications. Number One Systems Ltd, Harding Way, Somersham Road, St Ives, Cambs, PE17 4WR. Tel: 0480 61778.

Omni Electronics have sent their current catalogue, though they say that a new one will be issued towards the end of the year. Don't wait though, for their current cat has a great many items suited to the hobbyist constructor. They have a very wide selection of active and passive components, including semiconductors, resistors, capacitors, pots, knobs, stepper motors, uhf modulators, meters, etc. Of special interest to those who make their own pcbs are the items of pcb equipment and materials, including ferric chloride. Omni Electronics, 174 Dalkeith Road, Edinburgh, EH16 5DX. Tel: 031-667 2611.

Phonosonics' specialise in the supply of kits for published projects, many of them published in PE. Their latest catalogue has had many more kits added to the range, and covers projects as varied as computer add-ons, sound effects, music modifiers, test gear, environmental monitors, and even a few fun designs! Send a stamped addressed envelope to Phonosonics, Dept PEC, 8 Finucane Drive, Orpington, Kent, BR5 4ED. Tel: 0689 37821.

THE ABC OF ACTIVE BOOKS

News has come in of an intended product that could well represent the next significant wave in computing technology.

The Active Book Company is developing a pocket computer without a keyboard. The Book Computer will be about the size of a paperback book, and so fit into an inside jacket pocket. You will interact with the active book by using a pen which, in conceptual terms, writes on 'electronic paper'. The 'paper' will in fact be a liquid crystal display plus a transparent graphics tablet, and the pen an electronic stylus emitting a small electromagnetic field. The paper is arranged as pages in a book, with chapters and page numbers. Having the illusion of a book, ABC say that we can draw on the knowledge that people already have about books, their organisation into chapters, contents pages, indexes, and so on.

It is intended that the book should naturally fit into the existing computer environment and be compatible with both UNIX and MS-DOS operating systems. IBM PCs can be used as base stations with which active books communicate wherever they are in range of a comms link, typically within a ten metre radius.

The Active Book Co was conceived by Dr Hermann Hauser, pictured above, a founder of Acorn Computers in the late 70s, and developer of the BBC micro. For the last three years he has been Vice President of Research of the Olivetti



Group. With his link with Acorn, its probably not surprising that the heart of the active book is an Acorn product, the ARM, or Acorn Risc Machine. Using Risc architecture, the microprocessor is capable of very high speeds of operation since it has fewer instruction command sets with which to contend.

ABC expect that the book will cost less than £1000, and will additionally serve as a paperless fax machine. They also intend that it shall be a dictating machine, using an integral microphone, storing the spoken message in the computer's digital memory. ABC haven't disclosed the book's memory size, but in the region of at least 100 pages of text is likely, though could ultimately be as high as 300 pages.

The launch date of the active book is somewhat dependent on the availability of additional financial investment, but could be in about a year's time. If you've got a few quid to invest, you could well reap a fortune from the expected success of this new development.

The Active Book Company Ltd are at 4a Market Hill, Cambridge, CB2 3NJ. Tel : 0223 355144.



PE AT PC SHOW

Our sister magazine, *Program Now*, was on full display at September's PC Show at Earls Court and had a roaring success encouraging new readers and advertisers, as well as welcoming familiar friends.

Determined not to leave all the glory to our sister, PE prominently found a position on this year's enlarged stand. We'd just received the 25th Anniversary Issue from the printers and so were pleased and proud to have that

on display, together with enlarged colour posters of its cover and that of the very first issue from Nov 64. Behind the desk in the photo David Hewett and David Bonner attend to interested customers. On the right and ignoring the photographer, *PN* Editor Nigel Stuckey rests his elbow while discussing in depth programming.

Making a guest appearance (!) on the stand on the Friday, I was pleased to chat with several PE readers, including

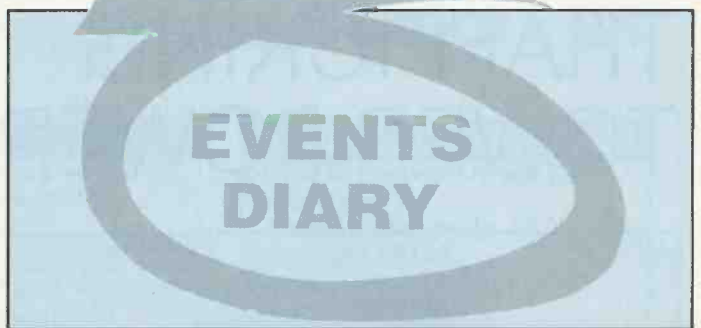

If you are organising any event to do with electronics, big or small, drop us a line, we shall be glad to include it here.

Please note : Some events listed here may be trade or restricted category only. Also, we cannot guarantee information accuracy, so check details with the organisers before setting out.

Nov 7-11. Productronica. 8th International Trade Fair for Electronics production. Munich Trade Fair Centre. 01-948 5166.

Nov 14-16. Total Solutions. Incorporating Drives, Motors, Controls, Interface, Data Acquisition, Telemetry UK, Coil Winding. NEC Birmingham. 0799 26699.

Dec 3. 8th 'Aerial' Christmas Vintage Wireless stall sale and swap-meet, Clarence House, Bristol. Entrance by advance ticket, booking forms from (sae please): Doris Roe, 7 Ashdown Road, Portishead, Bristol BS20 8DP.

1990

Mar 7-8. Laboratory 90. G-Mex Centre, Manchester. 0799 26699.

Mar 9-10. London Amateur Radio Show. Picketts Lock Centre, Edmonton, North London. Advance ticket sales and trade enquiries to The Secretary. LARS, 126 Mount Pleasant Lane, Bricket Wood, Herts AL2 3XD. 0923 678770.

Mar 28-29. Laboratory, Science & Technology Show. Kelsey Kerridge Sports Hall, Cambridge. 0799 26699.

Apr 9-11. Cable and satellite exhibition and conference. Olympia, London. 01-486 1951.

Apr 4-5. Drives, Motors, Controls. New Century Hall, Manchester. 0799 26699.

Apr 24-26. British Electronics Week. Olympia, London. 0799 26699.

Jun 26-28. Infrared Technology. Wembley Conference Centre. 0799 26699.

some who had been devotees for all 25 years. I was particular delighted to be warmly congratulated by two readers who said their choice of a career in electronics was directly attributable to PE's inspiration over the years. It was also amusing to be greeted by someone who recognised me from my 'digitised' (as he put it) picture on the editorial page! It turned out that he writes for *Wireless World* and now wishes to join my illustrious band of authors. Great places, are Shows!

PC SHOW PRAISES PUBLISHER

Show News, the daily news publication produced for exhibitors at the PC Show, devoted a short feature to our Publisher, Angelo. It told how

Angelo had become the originator not only of *Personal Computer World* magazine, but also of the PC Show itself.

Both ideas were conceived in the Troubadour coffee house, in the Brompton Road, London. "This quaint establishment", reported *Show News*, "brought together Meyer Solomon, a poet, programmer and linguist, and Angelo Zgorelec, a newsagent, magazine distributor and computer enthusiast. Between them, they dreamt up PCW."

"Angelo became publisher and Meyer the editor. Their first working premises were a corner bench in the Troubadour and a telephone box outside."

The first issue of *PCW* appeared on February 8th 1978.

Sometime, when Angelo isn't looking, perhaps I'll tell a fuller tale of his interesting publishing career; you'd be fascinated!

TRAFFICKING TOWER POWER



Traffic jams are no problem for this British Telecom technician as he steers his car 40 feet above the Suffolk countryside.

The vehicle is not a modern-day Chitty Chitty Bang Bang. It's being used in a test programme as part of a quality project sponsored by BT Mobile Communications to check the efficiency of various types of cellphone aerial.

Parked on its test-bed in the sky, the car can be easily manoeuvred. This enables radio signals from a nearby transmitter to be picked up at various angles by the vehicle's aerial, which is connected to monitoring equipment in the tower.

Roger Stuckey, who is in charge of the antenna test ranges at British Telecom's Martlesham Research Laboratories, explained: "It's not a gimmick, but serious research aimed at achieving a true representation of antenna performance."

"Mounting the aerial above ground eliminates possible interference to the radio signal, such as from surrounding buildings or nearby vehicles. The car itself, a scrap vehicle, creates a true-to-life situation of how the aerial would be located."

PROOP'S NEW SNOOP

At the beginning of September, Messers Proops opened their warehouse to the public.

The 10,000 sq ft warehouse, stocking a wide range of new and surplus items from solar panels to back magnets, from pcbs to valves, will be open six days a week, offering the professional and enthusiast alike an Aladdin's cave of surplus high and low-tech components, suitable for a wide range of projects and activities, at a fraction of the cost.

Managing Director Sydney Proops, who was part founder of Proops of Tottenham Court Road, says that the warehouse had already become a magnet for engineers, modellers, electronic enthusiasts, diy, research and development engineers and even design, theatre and film people looking for items for sets, and all he is now doing is to respond to the demand.

Sydney Proops said, "We have had so many people calling on the warehouse since the closure of the Tottenham Court Road Proops that we have decided to open the warehouse to the public. We believe that it is unique in the London area and possibly in the UK."

The warehouse is open from 9.00 am to 5.30 pm five days a week, and from 10.00 am until 2.00 pm on Saturdays. It can be reached by public transport; the nearest tube is Camden Town, the nearest railway station is also Camden Town and the bus service is the 214 which runs every 15 minutes Mondays to Fridays.

Proops of Tottenham Court Road opened in the early 1950s and closed some nine months ago with 'bereavement' notices in the specialist press and on LBC radio. During its 30 years of trading, the shop established a reputation second to none among professionals and hobbyists alike (including your Editor) for the quality of its high and low tech surplus materials and components.

Proop's warehouse is at Heybridge Estate, Castle Road, Camden Town, London. Tel: 01-267 1718

INMARSAT POWER-UP

Inmarsat's third generation satellite system will have enough power and capacity to offer a full range of multi-customer, worldwide mobile communications services using small, low-cost terminals.

The third generation satellite network will be highly flexible, capable of dynamically reallocating power and bandwidth on a global scale. This will allow Inmarsat to provide special coverage facilities to cope with particular service needs or emergencies around the world. The proposals are for three or four dedicated spacecraft with options for up to a total of nine.

The total EIRP (effective isotropically radiated power) of the satellites will be 48 dBW, nearly 10 times the effective capacity of the Inmarsat II satellites, due to be launched in 1990 and 1991, or 30 times the capacity of the satellites currently in operation. The liftoff mass is expected to be in the 1,800 - 2,500 kilogram range, and the satellites will feature a minimum of four spot beams for mobile communications in key service areas in addition to global coverage.

"Inmarsat's third generation satellites will have enough capacity to meet existing and new mobile services for projected demand into the 21st century," said Dr Ahmad Ghais, Inmarsat's Director of Engineering and Operations.

For further information, please contact: Elizabeth Hess, Inmarsat, 40 Melton Street, London NW1 2EQ. Tel: 01-387 9089.



STAR GENERATOR

SG4160B is a compact portable rf signal generator now available from Alpha Electronics. A wide frequency range from 100kHz to 150MHz can be both internally and externally modulated. This very low cost instrument is ideal for checking and aligning IF circuits and tuners in am/fm audio and video systems. Many applications are found in service and manufacturing industries as well as in education and with the hobbyist.

The six frequency ranges of this stable, solid state generator are clearly marked on a large dial and go from 100 to 320kHz, 300 to 1100kHz, 1 to 3MHz, 10 to 35MHz and 32 to 150MHz. Accuracy is ± 3 per cent with frequencies up to 450MHz

available on the third harmonic. Crystal oscillator facilities allow crystals from 1 to 15MHz of the HC-6U holder type to be plugged into the front panel. Output is controlled via a high/low attenuator and fine level control. Internal amplitude modulation is at 1kHz which is also available as an audio output. External modulating frequencies are from 50Hz to 20kHz.

Housed in an attractive case with a carrying handle, model SG4160B measures just 150 x 250 x 130mm and weighs approximately 2.5kg. AC power requirements are 115/230V 50/60Hz at approximately 3VA. This useful rf generator is fully guaranteed for one year and is available ex-stock at £79 plus vat.

For further information contact Alpha Electronics Ltd, Unit 5, Linstock Trading Estate, Wigan Road, Atherton, Manchester M29 0QA. Tel: 0942 873434.

CENTENNIAL UNDERTAKING

Yet another birthday to celebrate - this year sees the 100th anniversary of the Strowger telephone exchange. It was in 1889 that Kansas City undertaker Almon Strowger patented the idea for automatic switching. He was spurred on to invent the system after discovering his local telephone operator was married to his business rival - and was connecting potential customers to him!

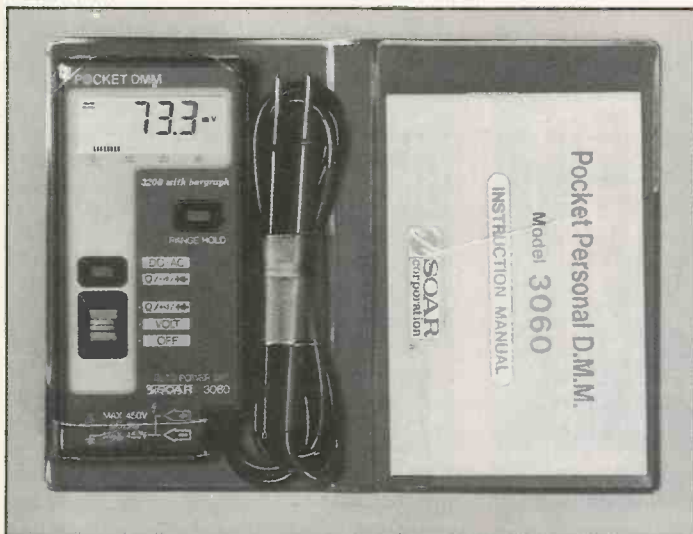

SOARLY NEEDED

The new ultra-compact Soar model 3060 is a uniquely designed, personal digital multimeter that incorporates a 3200 count, 3 1/2 digit read out, a 32 segment analog bar graph, a variety of advanced features and can be operated with one hand.

This dmm is ideal for quick, on-site applications and measures 51 x 106 x 10mm, weighs 100 grams and offers high speed auto or manual ranging. It delivers high speed sampling on the 32 segment bar graph display and is fully protected on all ranges to 450V. Virtually "drop-proof", the model includes an automatic power off feature which contributes to extra long battery life and low power consumption. The pocket-sized dmm also tests diodes and has a useful continuity beeper function.

The meter employs the dual slope integration method for measuring ac and dc voltages up to 450V, and resistances from 300 ohms to 30Mohms. It is supplied complete with a soft, protective carrying case to guard against accidental drops. Using standard LR44 or SR44 "button cell" batteries, it has both over-range and low battery indicators. Accessories include an instruction manual, test lead, protective case and two batteries.

Ideal for the technician, engineer or enthusiast, this new mini-dmm serves as an excellent "carry-along" instrument that belongs in every field kit.

For further details contact:
Solex International, 95 Main Street,
Broughton Astley, Leics LE9 6RE.
Tel: 0455 283486.



POWER ANALYSER

Now freely available from Northern Design is a technical data sheet for their new Power and Energy Analyser. Accurate, portable and easy to use, the PEA 200 digitally indicates Power as Wh,

Volts, Amps, Power Factor and Energy as Wh or kWh. Ideal for both single and 3 phase systems it measures from 1mA to 2000 Amps. Unaffected by waveform distortion the fundamental frequency can be from dc to 400Hz.

For further information contact: Ian Hutchinson, Northern Design (Electronics) Ltd., 228 Bolton Road, Bradford, West Yorkshire, BD3 0QW. Tel: 0274 729533.

CHIP COUNT

This month's choice of newly introduced chips for the spotlight.

NEW 555 TIMER

One of the most universally used chips in timing circuits has for many years been the good old 555. You'll be interested to know that another version has been added to the existing range of variations.

Philips has introduced two cmos timers to the range, the 74HC5555 and 74HCT5555, which offer substantial advantages over the popular bipolar 555 timer in terms of power consumption, increased precision and economy of external components. The latter are due to advances in the timer design.

In the new types, a frequency divider is driven by an oscillator and thus virtually eliminates timing variations due to threshold voltage variations. As the frequency divider divides by a programmed number ranging from 2 to 2¹⁴, low values of C and R can be used. Using a low value of capacitance can lead to substantial savings in both space and cost. In contrast, greater timing periods can be accomplished with fewer problems associated with capacitor leakage.

Facilities are provided for three oscillator arrangements. The internal oscillator can be used with either an external RC or crystal. Alternatively, an external oscillator can be used.

The 74HC5555 operates with normal cmos voltage levels, whilst the 74HCT5555 operates with ttl voltage level inputs. Both devices are comparable to, but improvements on, the 10343, which is available from other manufacturing sources. A related device from Philips is the 1CM7555C, which is a cmos version of the standard popular 555 timer.

PCF8578 AND PC8579 LCD DRIVERS

The Philips family of I²C-bus lcd drivers has been extended to include a new cmos chip set. The chip set is designed to drive medium-rate multiplex dot matrix lcds and consumes less than one twentieth the current of competing products, typically 20 microamps per chip. The set, which comprises types PCF8578 and PCF8579, will drive full graphics or character displays using between 1:8 and 1:32 multiplex and can be configured to drive from 256 up to a maximum of 40,960 dots.

The PCF8578 is an lcd row-and-column controller/driver with forty outputs which are typically used for driving 5-by-8 dot matrix displays, although any format is possible. Standing alone this chip can drive up to 384 dots in various combinations of rows and columns, depending on the multiplex rate. The ic can be cascaded with one or more PCF8579s for horizontally larger displays. The maximum configuration is 32 by 1280 dots.

The PCF8578 provides clock and display synchronisation for the PCF8579. It can work with up to 32 cascaded PCF8579s, either as a row/column driver, or as a row driver with up to 32 row outputs.

Overall control is exercised by a microcontroller, which communicates with the ics via a two-line bidirectional I²C-bus. The microcontroller thus controls the device's operation, and determines parameters such as the multiplex rate, blanking and loading modes. The address and bus lines of both chips are ttl and cmos compatible.

For more information on the chips highlighted above contact Philips Components Ltd, Mullard House, Torrington Place, London WC1E 7HD. Tel : 01-580 6633.

We all lose some of our hearing with age. The top end rolls off from 20 kHz at birth to 10 kHz in later years. Sensitivity to quiet sounds goes down too. But age alone does not usually cause complete deafness. Some people are born profoundly deaf, others lose their hearing through illness or exposure to excessively loud sound over a long period of time.

There are 50,000 people in Britain who rely on sign language for communication, one fifth of the deaf population. These people cannot communicate by phone. Conventional videophones can send and receive only still pictures so are no use for sign language conversation.

The new ISDN (Integrated Services Digital Network) works in the digital domain and can carry 64 kilobit/second pulse trains, which is enough to convey moving colour video. There is some blurring on motion but ISDN would allow sign language communication. However it will be many years before domestic subscribers get ISDN connections - if ever.

LEADING

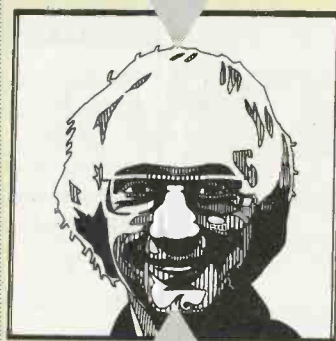

EDGE

The new system takes advantage of the fact that some areas of the picture, for instance corners, seldom contain motion. So there is no need to keep on transmitting the same digital description of the same picture part. The system transmits only information about changes in the picture, caused by motion, such as facial expressions and hand signs.

Processing circuitry in the modified videophone divides each full picture into 64 rectangular sections, in eight rows of eight. It then examines each section and compares it with a record of the last picture which has been temporarily stored in a solid state memory. When the picture content in a section remains the same, the transmitting videophone sends just one digital control bit down the line, indicating that the receiving videophone can pull that whole rectangle from its memory of the last picture, and display it unchanged.

When the processor senses that the picture content in a rectangle has changed, it splits the area into 16 smaller rectangles, four rows of four, and examines each

DEAF VIDEO PHONES

British Telecom has worked with the University of Essex to develop a new kind of video telephone which allows the deaf to "talk" by phone. It sends moving video pictures down conventional phone lines. The pictures look like black-on-white cartoon images but they convey sign language "characters". Facial characteristics are clear enough to allow callers to recognise each other.

People who have used the system say they would prefer to watch a full colour image, but BT has found that monochrome cartoon outlines are as accurate at conveying sign language messages as broadcast quality tv pictures. Although the hardware is still only in prototype form, BT believes that it will lead to a system which sells for "the price of a good quality video recorder".

The first working model has already been successfully used by one profoundly deaf couple between their home near Ipswich and the headquarters of the Suffolk Deaf Association. The main advantage of the system is that it does not require deaf people to learn the new discipline of typing text into a keyboard terminal.

BT's published description of the system was so garbled and superficial that most press reports failed to explain how the technology works. This is a pity because the system is clever and quite simple - once you have found the right person inside BT to explain it.

As a starting point, researchers at BT's laboratories at Martlesham and the University of Essex, took a videophone of the type already developed for ISDN use.

The videophone has a screen, 6 cm across, which displays a tv image made up

BY BARRY FOX
Winner of the
UK Technology Award

Briefly covered in last month's news page, the invention that will help the deaf communicate by phone is discussed in greater detail.

from 64 horizontal scanning lines. Each line is made up from 64 individual picture points or pixels. For an illusion of smooth motion, ten full pictures per second must be transmitted. The videophone thus needs to transmit information describing around 40,000 separate picture points per second (64 x 64 x 10).

If the technique used by fax machines is employed, whereby one digital bit switches each pixel between black and white, the data rate becomes 40 kb/s. This is well within the capability of a 64 kb/s ISDN line. But existing phone lines were designed to carry analogue speech, have a bandwidth of 3 kHz and can only carry data at a maximum of 14.4 kb/s. Often crackly lines reduce the top speed to 9.6 kb/s.

separately. Where there has been no change in a small rectangle, the transmitting phone sends one digital bit and the receiving videophone displays that area from memory. Where motion is detected in a rectangle, the processor splits the area again into even smaller rectangles. Again it sends one bit for each area where no motion is detected and again it subdivides any rectangle in which motion is sensed. This sub-division goes on until the system is examining individual pixels.

Because the amount of motion in the picture dictates the amount of digital bits needed, and because the amount of motion will always be changing, the data rate continually changes. On average the system reduces the number of bits by a factor of four, which brings communication within the capability of analogue phone lines.

Where there is so much motion over large areas of the screen that the system cannot reduce the data rate to the required 14.4 or 9.6 kilo bit/s, the processor automatically starts playing another trick. It reduces the number of full pictures sent from 10 per second to 8 or even 6. The motion on screen starts to look jerky and over-active callers are obliged to reduce the speed at which they make signs. So the system is self regulating.

In the future colour images will be sent over ISDN lines, with twelve bits used to describe each picture point, eight for monochrome detail and four for colour. The data rate will be reduced by the same technique of sensing motion and sending only essential information.

PE

Recently, an electronics teacher wrote to me about a couple of *PE* designs which had interested the enthusiastic pupils.

On receipt of the pcbs from the PCB Service the teacher had found that obtaining components was a tedious job due to now being tied to pin spacings. "In many cases", comments the teacher, "hole spacing and component sizes available from my usual supplier looked very silly. There are also some components which I am having difficulty locating. Please can authors be more precise on the purchasing source for components? I think saying that parts can be obtained from advertisers in the journal is something of a 'cop out' and loses you circulation quite unnecessarily."

It is not the authors who are responsible for the exclusion of component sources, it is strict publishing policy. There are two occasional exceptions to this. The first is when a particular component is only available from one supplier, who is then named as the source for that part. The second is an extension to the first, when an advertiser has instigated the project design and is the sole source of some parts, in which case he may be quoted as the kit source.

When items are believed to be readily available, we do not quote

PRACTICAL ELECTRONICS



COP OUT

a source. It would be highly offensive to source A if we quote source B when A stocks the parts as well. Nor can we quote both A and B, because in reality the list probably runs from A to Z. We know that this may mean that a reader has to shop around for parts, but in many cases it only takes a phone call or letter to a few suppliers to locate the parts. We also know that many readers have catalogues from many sources - it doesn't cost a lot to send off for them, and a lot of them are free. Anyone who is doing electronics as a serious hobby or subject is being unfair to themselves if they don't have a

reasonably sized catalogue library.

If a reader has difficulty locating a component of the same size as that used by the author, there are three main choices. One is to build the circuit on Veroboard or similar instead of a pcb. The second is to make the board oneself, modifying the track to accommodate the different sizes. The third, and easiest, is to carefully reshape the component leads or, if they are not suitable for this, to solder stout wires to them and then carefully bend the wires to shape.

It's worth while remembering that electronics is a pursuit that requires initiative and an analytical ability. The ability to think out alternative solutions to physical problems is just as important as the ability to find electronic, logical or mathematical solutions. Doing electronics is not like playing with plastic plug-in bricks. Certainly there are some things that can be achieved by doing little more than plug one bit to another, but the person who really wants to pursue electronics as a serious activity must not expect everything to be available on a plate. *PE* does its best to provide a very full plate of information, but readers may at times have to provide their own salt and pepper!

THE EDITOR

Editor:

John Becker

Sub-Editor:

Helen Armstrong

Technical Illustrator:

Derek Gooding

Advertisement Executives:

David Bonner, Richard Caplis

Office Manager:

Louise Hewett

Production Manager:

David Hewett

Publisher:

Angelo Zgorelec

Editorial and Advertising Address:

Practical Electronics,
Intra House, 193 Uxbridge Road,
London W12 9RA
Tel: 01-743 8888
Telecom Gold: 87: SQQ567
Fax: 01-743 3062

Advertisements

All correspondence relating to advertise-



ments, including classified ads, should be addressed to: **The advertisement department, Practical Electronics, at the above address and telephone number.**

Readers' Enquiries

All editorial correspondence should be addressed to the editor and any letters requiring a reply should be accompanied by a stamped addressed envelope, or equivalent payment.

We regret that lengthy technical enquiries cannot be answered over the phone.

Subscription Address:

Practical Electronics, Subscription Dept.,
P.O. Box 500, Leicester LE99 0AA.

Annual Subscription Rates:

U.K. £15.00 Overseas £18.00

Cover Illustration

Science Photo Library

© Intra Press 1989. Copyright in all drawings, photographs and articles published in PRACTICAL ELECTRONICS is fully protected, and reproduction or imitations in whole or in part are expressly forbidden. All reasonable precautions are taken by PRACTICAL ELECTRONICS to ensure that the advice and data given to readers is reliable. We cannot, however, guarantee it, and we cannot accept legal responsibility for it. Prices quoted are those current as we go to press. All material is accepted for publication on the express understanding that the contributor has the authority to permit us to do so. **ISSN 0032-6372**

Published on 1st Friday of each month by Intrapress, 193 Uxbridge Road, London W12 9RA. Printed in England by Andover Press Ltd. Andover, Hants. Distributed by Quadrant Publishing Services 01-661 8526. PRACTICAL ELECTRONICS is sold subject to the following conditions, namely that it shall not, without the written consent of the Publishers first having been given, be lent, resold, hired out or otherwise disposed of by way of Trade at more than the recommended selling price shown on the cover, and that it shall not be lent, resold, hired out or otherwise disposed of in a mutilated condition or in any unauthorised cover by way of Trade or affixed to or as part of any publication or advertising. Literary or pictorial matter whatsoever.

For fast delivery telephone
your order on 01-205 9558
using VISA Access Card



Orders welcome from
government depts &
educational establishments

TECHNOMATIC

Techno House 468 Church Lane, London NW9 8TQ.

Tel: 01-205 9558 Fax: 01-205 0190

All prices ex VAT
Prices are subject to
change without notice
Please add carriage
(a) £8.00 (Courier)
(b) £3.50
(c) £1.50
(d) £1.00

Archimedes Computer Systems

All Archimedes systems are fitted with new RISC OS systems.

Model	Basic	Colour*
A3000	£649	£849
310	£899	£1099
410/1	£1199	£1399
420/1	£1699	£1899
440/1	£2499	£2699
PC Emulator	£60	

Carriage £12/system £8/computer

*Colour monitor can be Acorn AKF11 or Philips CM8833

Technomatic Special Deal

To get you going on any of the above Archimedes systems you purchase from us, we will contribute 10% of its cost towards any additional hardware or software purchase you make from us or to pay for extended finance if you require the facility.

The following MultiScan Monitors can be supplied at special prices when purchased with a computer:

TAXAN 770+	£419(a)	MTS9600	£375(a)
CM1686 16"	£1499(a)		

(for the extra HiRes modes on 400 series)

Extended Finance

We can offer extended finance for 11 months under our special offer detailed above or for 24/36 month period at 12.75% (approx APR 26%). Please send for details. Technomatic is a licensed credit broker.

R140 UNIX SYSTEM

Technomatic is an authorised dealer.
Pse send for details

Techno 410/1 Upgrade Specials

3Mb RAM + 49Mb HD (fitted)	£840
3Mb RAM + 40Mb HD (fitted)	£720
1Mb RAM + 20Mb HD (fitted)	£325

(All hard drives are with fast access times)

These prices apply only when purchased with Arc 410/1 (Your discount entitlement can be used towards paying for any of the above kits)

EXPANSION SYSTEMS

RISCOS kit (305/310/440)	£29(b)
1Mb RAM upgrade (410)	£149(c)
3Mb RAM upgrade (410)	£429(b)
2Mb upgrade (420)	£290(b)
1Mb RAM upgrade A3000	£199(b)
3.5" Int Drive Upgrade	£118(b)
(please specify 305/310 or 410)	
External Drive Adaptor	£30(c)
External 5.25" Drive with psu (40/80T)	£90(b)
Acorn 20 Mb Upgrade (305/310)	£449(a)
Techno 20Mb upgrade kit (410)	£199(a)
Techno 40Mb upgrade kit (410)	£349(a)
Techno 49Mb upgrade kit (410)	£465(a)
Techno Ext HD upgrade (300 & 400 series)	POA
Acorn Backplane (2 slots)	£37(c)
TechnoLog Backplane (4 slots)	£39(c)
Fan for TechnoLog	£8(d)
Acorn ROM podule	£51(c)

We have a large range of expansion cards in stock please send for details.

MULTI I/O Podule

A low cost card provides: Video Digitiser, Sound Sampler, a full RS232 interface, 3 ROM skts & Joystick interface within RISCOS environment. Details on request. £117(b)

Archimedes SOFTWARE

LANGUAGES & PROG. TOOLS

ANSI C/ISO PASCAL/ FORTRAN 77	each £95(c)
PROLOG X/LISP	each £175(b)
TWIN Editor	£27(d)
Archimedes Assembler	£185(b)
Software Dev. Toolbox	£185(b)
RISC BASIC Compiler (SV)	£85(c)
Chares Toolkit	£32(d)
Clares Toolkit+	£41(d)

WORD PROCESSORS

1st Word Plus	£79(c)	Graphics Writer	£27(d)
Pipedream	£89(c)	P. Spellchecker	£43(d)
Pipedream Ver 3 (inc Spelling checker)	£129(c)		

SPREADSHEETS

Logistix	£95(c)	SigmaSheet	£57(c)
----------	--------	------------	--------

ACCOUNT SYSTEM

Minerva's Suite*	each £54(d)
(Order Processing/Sales Ledger/Stock Manager/ Purch. Ledger/Nom. Ledger)	
*Requires System Delta plus	
Home Accounts	£41(d)

GRAPHICS/ART/CAD

Pro Artisan	£137(b)	Artisan	£30(d)
Artisan Support Disc			£17(d)
Atelier	£90(b)	Auto Sketch	£55(c)
Gamma Plot	£52(d)	Render Bender	£59(b)
Presenter	£24(d)	SVARC-PCB	£167(b)
SV Solid CAD	£41(d)	SV Super Dump	£20(d)
Sv Real Time Solids Modeller			£75(c)

NEW PRODUCTS

technoSCAN Scanner 200dpi £159(b)
Genius Digitising Tablet £249

GAMES

Hoverbod/Missile Control	each £12(d)		
Orion/Freddie's Folly/Jet Fighter	each £12(d)		
Fugitive Quest/Rise in Crime/Overload	each £26(d)		
Zarch	£15(d)	Conqueror	£24(d)
Enthar Seven	£29(d)	Minotaur	£9(d)
Clares 3 Pack	£12(d)	Viking	£17(d)
Thundermonk	£12(d)	Corruption	£20(d)
Pacmaria	£16(d)	Terramex	£16(d)

DATABASES

System Delta Plus	£57(c)
System Delta Plus Prog Ref Manual	£25(d)
Reporter*/Mailshot*	each £33(d)
School Administrator	£125(b)
Alphabase	£37(d)
*Requires System Delta plus	

MISCELLANEOUS

PC Emulator	£79(d)
HEARSAY Comms Package	£55(d)
MAYA Terminal Emulator	£29(d)
Control (setup utility)	£13(d)
(inc VT52, ANSI, Tektronix 4034, Kermit protocols)	
Arcomm	£29(d)
Presenter II	£POA

EMULATED PACKAGES

VIEW/Viewsheet/Viewstore	each £47(d)
Interword/Intersheet	each £35(d)
Wordwise	£20(d)

EX-SERVICE EQUIPMENT

Our Service department has a number of disc drives, monitors and printers available for sale at reduced prices. Please send for detailed list.

MASTER SERIES

AMB15 Master 128 £439(a)

The Master package includes: View Word processor and Viewsheet spreadsheet software and EITHER Educational/Fun software bundle with STARdataBASE package OR A 200K 40T DS single drive TS200. Please specify your choice.

ADC06 Turbo 65C102 Module £115(b)

Technomatic is a Acorn Authorised Econet Referral Centre. We carry a full range of Econet Accessories in stock.

DISC DRIVES

400K/640K per mechanism (all drives)

5.25" Double sided (40/80T Sw):

TS400 Single	£80(b)
PS400 Single with psu	£90(b)
TD800 Dual	£160(a)
PD800 Dual with psu	£170(a)
PD800P Dual with psu plinth mounted	£185(a)
3.5" Double Sided	
TS351 (5.25")	£69(b)
PS351 (5.25" Case + psu)	£95(b)
TD352 Dual	£126(a)
PD352 Dual with psu	£139(a)

Combo Drives 5.25" + 3.5" & psu

PD853	£170(a)
PD853P plinth mounted	£190(a)

WINCHESTER DRIVES

P30HD 30Mb Hard Drives	£410(a)
Other sizes available	

PRINTERS

EPSON

LX800	£145(a)	LQ500	£225(a)
FX850	£285(a)	LQ850	£405(a)

STAR

LC10	£149(a)	LC10 Colour	£199(a)
		LC24-10	£269(a)

NATIONAL PANASONIC

KXP1081 incl master lead	£139(a)
KXP1124	£269(a)
Integrex Inkjet Colour	£515(a)
Hitachi 672XD A3 Plotter	£479(a)

PLOTTERS

Hitachi 672XD A3 4 pen plotter Special £409(a)
Roland DXY880A A3 Flatbed 8 pen plotter £495(a)

This advertisement can only show an example of the range of products stocked by Technomatic. So send for our latest free BBC catalogue providing detailed information and prices on BBC Computer Systems, Peripherals, Software and Books.

NAME.....

ADDRESS.....

Post Code.....

Return to Technomatic Ltd, Techno House,
468 Church Lane, London NW9 8TQ.

Please mention **Practical Electronics** when contacting advertisers

TTLs		LINEAR ICs		CPU's		RAMS		CRYSTALS		INTERFACES	
7400	74393	74LS379	4536	AD581	12.00	LM723	0.60	TC9109	5.00	68B09	10.00
7401	74393	74LS381	4538	ADC0808	11.90	LM725CN	4.00	TC9490	1.00	68B09E	12.00
7402	74393	74LS390	4540	AD7910DC	25.00	LM731	0.65	TD4120	2.25	2016	4.00
7403	74393	74LS393	4541	AN103	2.00	LM741	0.22	TD1022	4.50	2107A	5.00
7404	74393	74LS395A	4543	AY1 5050	1.00	LM747	0.70	TD1024	1.50	2111A-35	4.00
7405	74393	74LS399	4551	AY3 8010	4.50	LM748	0.30	TD1170S	3.00	2114-3	2.50
7406	74393	74LS400	4553	CA3080	1.00	LM751	0.30	TD2002	3.25	2114-35	4.00
7407	74393	74LS405	4555	CA3091	0.80	LM751A	1.50	TD2003	3.00	2114-35	4.00
7408	74393	74LS406	4556	CA3092A	1.10	LM752	0.30	TD2004	2.40	2114-35	4.00
7409	74393	74LS407	4557	CA3092B	1.10	LM753	0.35	TD2005	2.40	2114-35	4.00
7410	74393	74LS408	4558	CA3094	1.10	LM753	0.35	TD2006	2.40	2114-35	4.00
7411	74393	74LS409	4559	CA3095	1.10	LM754	0.35	TD2007	2.40	2114-35	4.00
7412	74393	74LS410	4560	CA3096	1.10	LM755	0.35	TD2008	2.40	2114-35	4.00
7413	74393	74LS411	4561	CA3097	1.10	LM756	0.35	TD2009	2.40	2114-35	4.00
7414	74393	74LS412	4562	CA3098E	2.50	LM757	0.35	TD2010	2.40	2114-35	4.00
7415	74393	74LS413	4563	CA3099A	3.75	LM758	0.35	TD2011	2.40	2114-35	4.00
7416	74393	74LS414	4564	CA3100E	0.90	LM759	0.35	TD2012	2.40	2114-35	4.00
7417	74393	74LS415	4565	CA3101E	0.90	LM760	0.35	TD2013	2.40	2114-35	4.00
7418	74393	74LS416	4566	CA3102E	0.90	LM761	0.35	TD2014	2.40	2114-35	4.00
7419	74393	74LS417	4567	CA3103E	0.90	LM762	0.35	TD2015	2.40	2114-35	4.00
7420	74393	74LS418	4568	CA3104E	1.30	LM763	0.35	TD2016	2.40	2114-35	4.00
7421	74393	74LS419	4569	CA3105E	1.30	LM764	0.35	TD2017	2.40	2114-35	4.00
7422	74393	74LS420	4570	CA3106E	1.30	LM765	0.35	TD2018	2.40	2114-35	4.00
7423	74393	74LS421	4571	CA3107E	1.30	LM766	0.35	TD2019	2.40	2114-35	4.00
7424	74393	74LS422	4572	CA3108E	1.30	LM767	0.35	TD2020	2.40	2114-35	4.00
7425	74393	74LS423	4573	CA3109E	1.30	LM768	0.35	TD2021	2.40	2114-35	4.00
7426	74393	74LS424	4574	CA3110E	1.30	LM769	0.35	TD2022	2.40	2114-35	4.00
7427	74393	74LS425	4575	CA3111E	1.30	LM770	0.35	TD2023	2.40	2114-35	4.00
7428	74393	74LS426	4576	CA3112E	1.30	LM771	0.35	TD2024	2.40	2114-35	4.00
7429	74393	74LS427	4577	CA3113E	1.30	LM772	0.35	TD2025	2.40	2114-35	4.00
7430	74393	74LS428	4578	CA3114E	1.30	LM773	0.35	TD2026	2.40	2114-35	4.00
7431	74393	74LS429	4579	CA3115E	1.30	LM774	0.35	TD2027	2.40	2114-35	4.00
7432	74393	74LS430	4580	CA3116E	1.30	LM775	0.35	TD2028	2.40	2114-35	4.00
7433	74393	74LS431	4581	CA3117E	1.30	LM776	0.35	TD2029	2.40	2114-35	4.00
7434	74393	74LS432	4582	CA3118E	1.30	LM777	0.35	TD2030	2.40	2114-35	4.00
7435	74393	74LS433	4583	CA3119E	1.30	LM778	0.35	TD2031	2.40	2114-35	4.00
7436	74393	74LS434	4584	CA3120E	1.30	LM779	0.35	TD2032	2.40	2114-35	4.00
7437	74393	74LS435	4585	CA3121E	1.30	LM780	0.35	TD2033	2.40	2114-35	4.00
7438	74393	74LS436	4586	CA3122E	1.30	LM781	0.35	TD2034	2.40	2114-35	4.00
7439	74393	74LS437	4587	CA3123E	1.30	LM782	0.35	TD2035	2.40	2114-35	4.00
7440	74393	74LS438	4588	CA3124E	1.30	LM783	0.35	TD2036	2.40	2114-35	4.00
7441	74393	74LS439	4589	CA3125E	1.30	LM784	0.35	TD2037	2.40	2114-35	4.00
7442	74393	74LS440	4590	CA3126E	1.30	LM785	0.35	TD2038	2.40	2114-35	4.00
7443	74393	74LS441	4591	CA3127E	1.30	LM786	0.35	TD2039	2.40	2114-35	4.00
7444	74393	74LS442	4592	CA3128E	1.30	LM787	0.35	TD2040	2.40	2114-35	4.00
7445	74393	74LS443	4593	CA3129E	1.30	LM788	0.35	TD2041	2.40	2114-35	4.00
7446	74393	74LS444	4594	CA3130E	1.30	LM789	0.35	TD2042	2.40	2114-35	4.00
7447	74393	74LS445	4595	CA3131E	1.30	LM790	0.35	TD2043	2.40	2114-35	4.00
7448	74393	74LS446	4596	CA3132E	1.30	LM791	0.35	TD2044	2.40	2114-35	4.00
7449	74393	74LS447	4597	CA3133E	1.30	LM792	0.35	TD2045	2.40	2114-35	4.00
7450	74393	74LS448	4598	CA3134E	1.30	LM793	0.35	TD2046	2.40	2114-35	4.00
7451	74393	74LS449	4599	CA3135E	1.30	LM794	0.35	TD2047	2.40	2114-35	4.00
7452	74393	74LS450	4600	CA3136E	1.30	LM795	0.35	TD2048	2.40	2114-35	4.00
7453	74393	74LS451	4601	CA3137E	1.30	LM796	0.35	TD2049	2.40	2114-35	4.00
7454	74393	74LS452	4602	CA3138E	1.30	LM797	0.35	TD2050	2.40	2114-35	4.00
7455	74393	74LS453	4603	CA3139E	1.30	LM798	0.35	TD2051	2.40	2114-35	4.00
7456	74393	74LS454	4604	CA3140E	1.30	LM799	0.35	TD2052	2.40	2114-35	4.00
7457	74393	74LS455	4605	CA3141E	1.30	LM800	0.35	TD2053	2.40	2114-35	4.00
7458	74393	74LS456	4606	CA3142E	1.30	LM801	0.35	TD2054	2.40	2114-35	4.00
7459	74393	74LS457	4607	CA3143E	1.30	LM802	0.35	TD2055	2.40	2114-35	4.00
7460	74393	74LS458	4608	CA3144E	1.30	LM803	0.35	TD2056	2.40	2114-35	4.00
7461	74393	74LS459	4609	CA3145E	1.30	LM804	0.35	TD2057	2.40	2114-35	4.00
7462	74393	74LS460	4610	CA3146E	1.30	LM805	0.35	TD2058	2.40	2114-35	4.00
7463	74393	74LS461	4611	CA3147E	1.30	LM806	0.35	TD2059	2.40	2114-35	4.00
7464	74393	74LS462	4612	CA3148E	1.30	LM807	0.35	TD2060	2.40	2114-35	4.00
7465	74393	74LS463	4613	CA3149E	1.30	LM808	0.35	TD2061	2.40	2114-35	4.00
7466	74393	74LS464	4614	CA3150E	1.30	LM809	0.35	TD2062	2.40	2114-35	4.00
7467	74393	74LS465	4615	CA3151E	1.30	LM810	0.35	TD2063	2.40	2114-35	4.00
7468	74393	74LS466	4616	CA3152E	1.30	LM811	0.35	TD2064	2.40	2114-35	4.00
7469	74393	74LS467	4617	CA3153E	1.30	LM812	0.35	TD2065	2.40	2114-35	4.00
7470	74393	74LS468	4618	CA3154E	1.30	LM813	0.35	TD2066	2.40	2114-35	4.00
7471	74393	74LS469	4619	CA3155E	1.30	LM814	0.35	TD2067	2.40	2114-35	4.00
7472	74393	74LS470	4620	CA3156E	1.30	LM815	0.35	TD2068	2.40	2114-35	4.00
7473	74393	74LS471	4621	CA3157E	1.30	LM816	0.35	TD2069	2.40	2114-35	4.00
7474	74393	74LS472	4622	CA3158E	1.30	LM817	0.35	TD2070	2.40	2114-35	4.00
7475	74393	74LS473	4623	CA3159E	1.30	LM818	0.35	TD2071	2.40	2114-35	4.00
7476	74393	74LS474	4624	CA3160E	1.30	LM819	0.35	TD2072	2.40	2114-35	4.00
7477	74393	74LS475	4625	CA3161E	1.30	LM820	0.35	TD2073	2.40	2114-35	4.00
7478	74393	74LS476	4626	CA3162E	1.30	LM821	0.35	TD2074	2.40	2114-35	4.00
7479	74393	74LS477	4627	CA3163E	1.30	LM822	0.35	TD2075	2.40	2114-35	4.00
7480	74393	74LS478	4628	CA3164E	1.30	LM823	0.35	TD2076	2.40	2114-35	4.00
7481	74393	74LS479	4629	CA3165E	1.30	LM824	0.35	TD2077	2.40	2114-35	4.00
7482	74393	74LS480	4630	CA3166E	1.30	LM825	0.35	TD2078	2.40	2114-35	4.00
7483	74393	74LS481	4631	CA3167E	1.30	LM826	0.35	TD2079	2.40	2114-35	4.00
7484	74393	74LS482	4632	CA3168E	1.30	LM827	0.35	TD2080	2.40	2114-35	4.00
7485	74393	74LS483	4633	CA3169E	1.30	LM828	0.35	TD2081	2.40	2114-35	4.00
7486	74393	74LS484	4634	CA3170E	1.30	LM829	0.35	TD2082	2.40	2114-35	4.00
7487	74393	74LS485	4635	CA3171E	1.30	LM830	0.35	TD2083	2.40	2114-35	4.00
7488	74393	74LS486	4636	CA3172E	1.30	LM831	0.35	TD2084	2.40	2114-35	4.00
7489	74393	74LS487	4637	CA3173E	1.30	LM832	0.35	TD2085	2.40	2114-35	4.00
7490	74393	74LS488	4638	CA3174E	1.30	LM833	0.35	TD2086	2.40	2114-35	4.00
7491	74393	74LS489	4639	CA3175E	1.30	LM834	0.35	TD2087	2.40	2114-35	4.00
7492	74393	74LS490	4640	CA3176E	1.30	LM835	0.35	TD2088	2.40	2114-35	4.00
7493	74393	74LS491	4641	CA3177E	1.30	LM836	0.35	TD2089	2.40	2114-35	4.00
7494	74393	74LS492	4642	CA3178E	1.30	LM837	0.35	TD2090	2.40	2114-35	4.00
7495	74393	74LS493	4643	CA3179E	1.30	LM838	0.35	TD2091	2.40	2114-35	4.00
7496	74393	74LS494	4644	CA3180E	1.30	LM839	0.35	TD2092	2.40	2114-35	4.00
7497	74393	74LS495	4645	CA3181E	1.30	LM840	0.35	TD2093	2.40		

There have been a number of systems over the years which have been designed to combat video and audio "pirating". The success of such systems seems, so far at any rate, to have been strictly limited. The problem is in finding a system that renders a video tape (or whatever) uncopyable without making it unplayable as well! Also, there must obviously be no easy way of defeating the system.

SYNC DOCTOR

Early attempts at copy protection for video tapes centred around doctoring of the synchronisation pulses. They seem to have been rather unsuccessful, with no ideal compromise being possible. Doctoring the synchronisation pulses sufficiently to make tapes uncopyable also tended to make them unplayable on some video recorders. Using a more mild form of doctoring eliminated this problem, but meant that the tapes could be copied using some recorders. Large sums of money were reported to have been lost by companies who had to exchange doctored tapes that proved to be unusable by their purchasers.

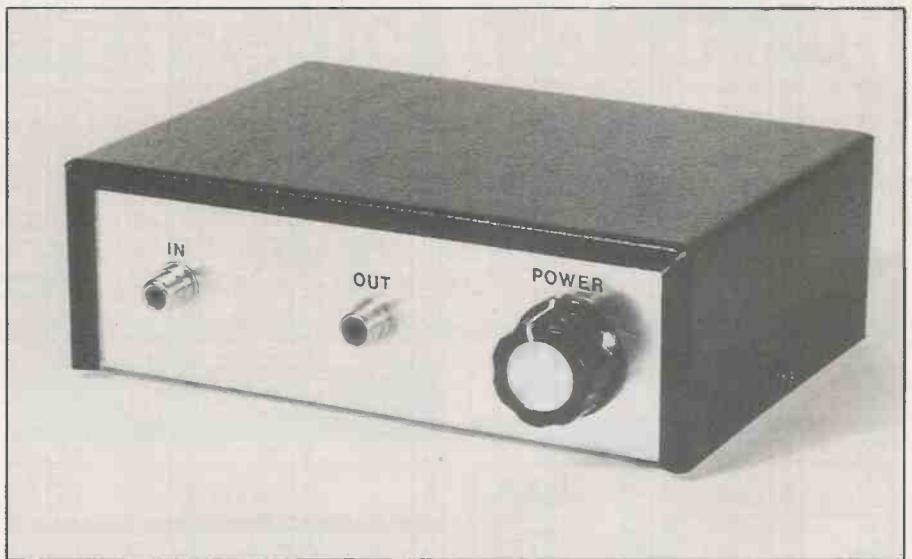

who owns equipment which gives problems when playing back some of the latest films! There is a way around the problem which involves the use of so-called agc stabilisation. This usually involves removing some or all of the offending pulses via an out-board unit rather than any tampering with the agc circuits of the video equipment.

The unit described here is designed to "wipe" the initial part of each video frame (ie the part where the Teletext signal goes in a broadcast television signal) and should help if used with equipment that has problems playing back copy protected tapes. It processes the composite video signal, and is designed to fit between the recorder and a monitor, or the monitor input

VIDEO AGC STABILISER

Modern techniques are more sophisticated, and in general are successful. Rather than altering the synchronisation pulses in some way, the current trend is to add extra pulses to the recorded signal. These are not designed to fool the synchronisation circuits of the recorder at all, but are aimed at confusing the agc circuits. The effect of copying a tape that is protected in this way is said to be periods of very high and very low picture brightness, making the copy totally unusable. This system still relies on recording equipment responding to the signal from the tape in one way, while playback equipment responds to it in another. With a wide variety of video equipment using different techniques in widespread use, there are inevitably some people who run into problems (and presumably some people who have recorders that are "blind" to the doctoring techniques).

AGC STABILISATION

It would seem likely that anyone who buys or hires a video tape that gives less than good results when played on fully working video equipment is legally entitled to a refund. After all, any doctored or added pulses are not part of the VHS standard. This is probably cold comfort to anyone

BY ROBERT PENFOLD

Some video recorders can't replay copy-protected tapes correctly. This signal-cleaner re-addresses the problem.

of a television which has this facility. It should be possible to feed the output of this processor into a suitable modulator unit so that it can be used with a television set that does not have a monitor input. However, as yet I have not tried this.

BLANKED OUT

The function the unit must provide is quite simple, and merely involves blanking out the initial section of each frame (or the very top part of the screen if you prefer to look at it this way). Matters are complicated by the fact that video signals are quite complex. There is the positive going picture modulation signal, the negative

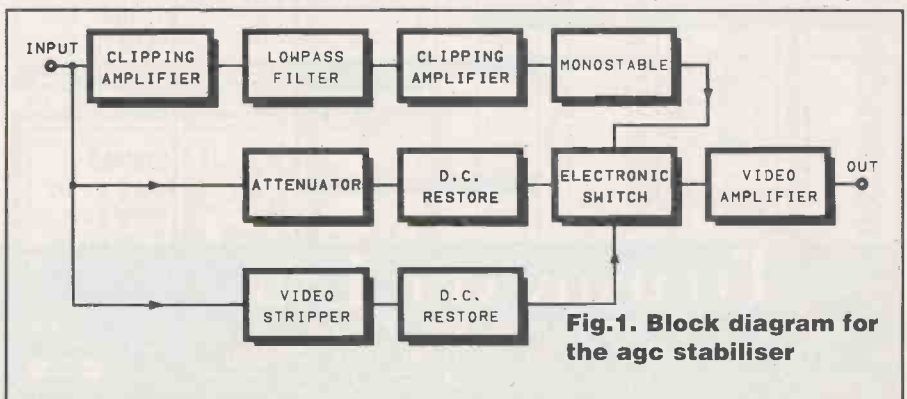
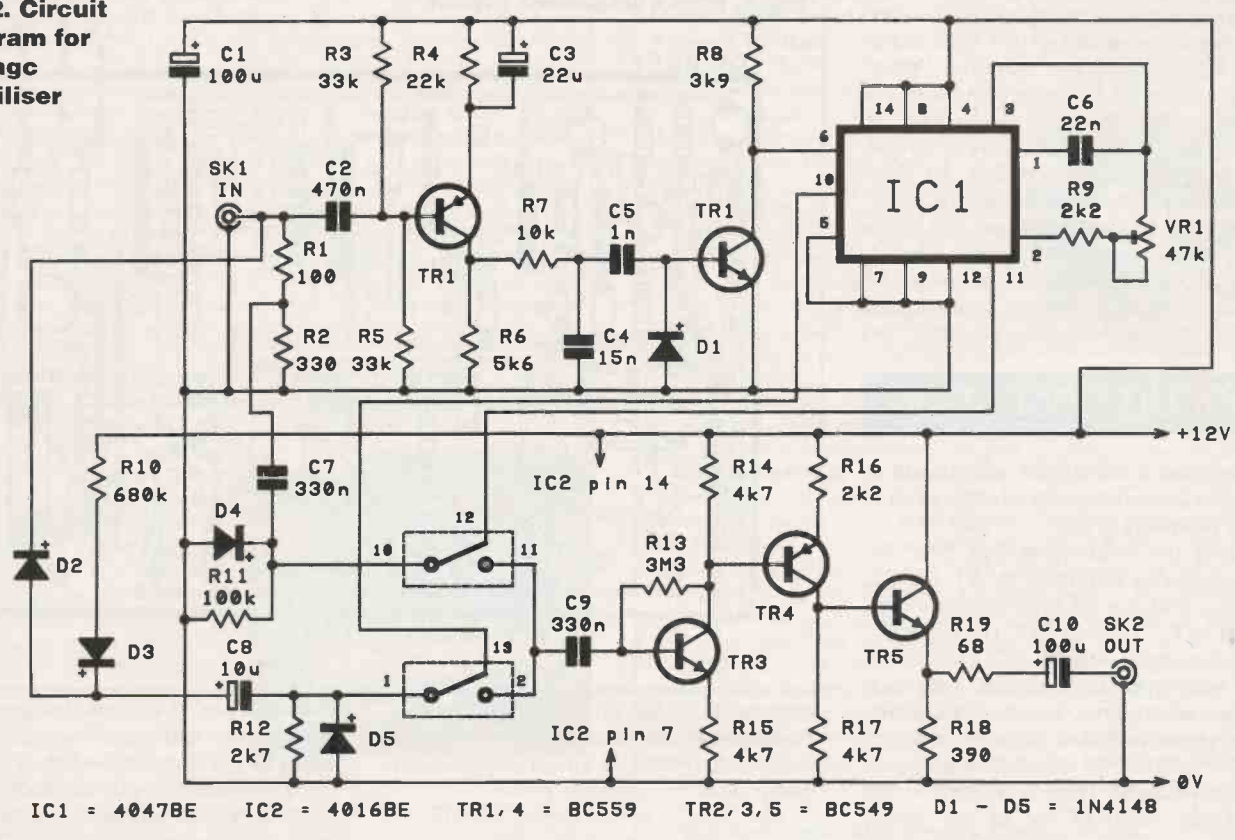

Fig.1. Block diagram for the agc stabiliser

Fig.2. Circuit diagram for the agc stabiliser



IC1 = 4047BE IC2 = 4016BE TR1, 4 = BC559 TR2, 3, 5 = BC549 D1 - D5 = 1N4148

synchronisation pulses, and the colour burst signal somewhere in between. The important point to note when blanking part of a video signal is that the synchronisation signal must not be blanked. It must be left largely intact or problems with picture roll, a shifted picture, or even a complete loss of synchronisation will result. Fig.1 shows the block diagram for the agc stabiliser, and helps to explain the way in which the synchronisation problem is overcome.

The main signal path is through an attenuator, a dc restoration circuit, an electronic switch, and a video amplifier. This is the route that the signal takes for the vast majority of the time, and it only takes the alternative route during the brief blanking periods. With the electronic switch (which is a changeover type) set to the opposite position, the signal path is through the video stripper, another dc

restoration stage, the electronic switch, and the video amplifier. The video stripper is a form of diode clipping circuit, and its effect is to clip off the positive going video signal while leaving the negative going synchronisation pulses largely unaffected. These pulses are attenuated slightly by the stripper circuit, and it is for this reason that the unprocessed signal is taken to the electronic switch via an attenuator. This ensures that the two signals have well matched amplitudes when they reach the electronic switch.

By switching over to the secondary signal path during the blanking periods, the modulation signal (complete with extra pulses) is removed while the synchronisation signal is maintained. This system works well in practice, but there is a potential problem caused by a lack of symmetry in the circuits ahead of the

electronic switch. This results in the bias levels of the two signals tending to drift apart so that there are large dc jumps as the electronic switch chops from one signal to the other. It is not possible to preset the bias levels so that the signals are kept precisely in step. They might start out at suitably matched bias levels, but changes in the intensity of the modulation signal would soon have them drifting apart again, and by quite substantial amounts. The dc restoration circuits overcome this problem by keeping both signals with their negative peaks at the 0 volt supply level. This also ensures that both signals are kept at voltages that can be handled properly by the electronic switch. The video amplifier at the output of the unit compensates for the losses through the other circuits in the signal path. It also provides the circuit with the correct output impedance (75 ohms).

Fig.3. The mains power supply circuit.

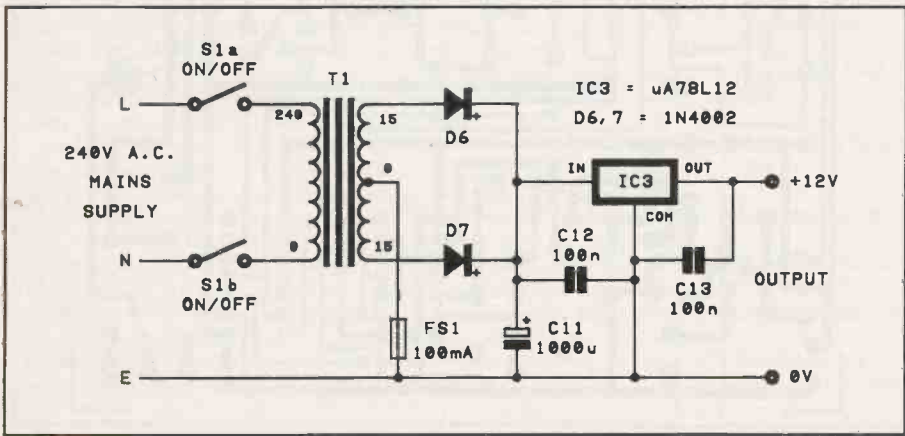

The rest of the unit is devoted to producing the blanking signal. The synchronisation pulses consist of frame pulses at a frequency of 50Hz, and line pulses at a frequency of 15.625kHz. There are actually only twenty five complete pictures per second, with two interlaced frames making up each complete picture. This system gives reduced picture flicker. The blanking pulse can be provided by a monostable multivibrator triggered on the leading (negative going) edge of each frame synchronisation pulse. However, these pulses must first be filtered out from the other elements of the signal, particularly the line synchronisation pulses.

First the signal is severely clipped, and this effectively removes the picture

modulation signal. A lowpass filter then substantially attenuates the line synchronisation signals. Apart from being at a higher repetition frequency, these pulses are also much shorter than the frame synchronisation pulses (about 5µs as opposed to 160µs in fact). Quite simple lowpass filtering can therefore be very effective at reducing the higher frequency pulses while leaving the longer and much lower frequency ones largely intact. Another clipping amplifier processes the filtered pulses to produce a strong signal that can drive the monostable properly.

CIRCUIT OPERATION

The main circuit of the unit appears in Fig.2, but the mains power supply circuit is shown separately in Fig.3.

Taking the main signal path first; the input attenuator is formed by R1 and R2, and these feed into the dc restoration circuit formed by C7, D4, and R11. The electronic switch is a cmos 4016BE (IC2) which is a quad spst type. In this case only two switches are required, and these are driven in anti-phase with their outputs connected together so that the required changeover action is obtained. There is no need to add an inverter ahead of one of the control inputs because the monostable has anti-phase (Q and not-Q) outputs.

The video amplifier is a three stage dc coupled circuit based on TR3 to TR5. This has two common emitter amplifiers (TR3 and TR4) followed by an emitter follower output stage (TR5). Although common emitter amplifiers normally have a very high voltage gain, in this circuit the voltage gain is kept down to the required level of about 6dB (two times) by the use of massive amounts of local negative feedback. This feedback is provided by the unbypassed emitter resistors (R15 and R16). A useful byproduct of this negative feedback is that it gives the amplifier a wide bandwidth of several megahertz. Remember that we are dealing with video signals, and that these contain frequencies well into the megahertz range. On the face of it there is no reason for including the second common emitter stage. It is essential though, as there is a phase inversion through each common emitter stage, and the second stage is needed in order to re-invert the signal back to the correct phase. Unlike audio signals, the correct phasing of video signals is crucial. The picture modulation must be positive going and the synchronisation signals must be negative pulses. TR5 gives the amplifier a low output impedance, and R19 trims the output impedance to give the correct figure of (near enough) 75 ohms.

D2 acts as the basis of the video stripper circuit. The bias provided by R10 controls how severely the signal is clipped, and the value of this component has been selected to give a good compromise between attenuation of the modulation signal and

Fig.4. PCB component layout

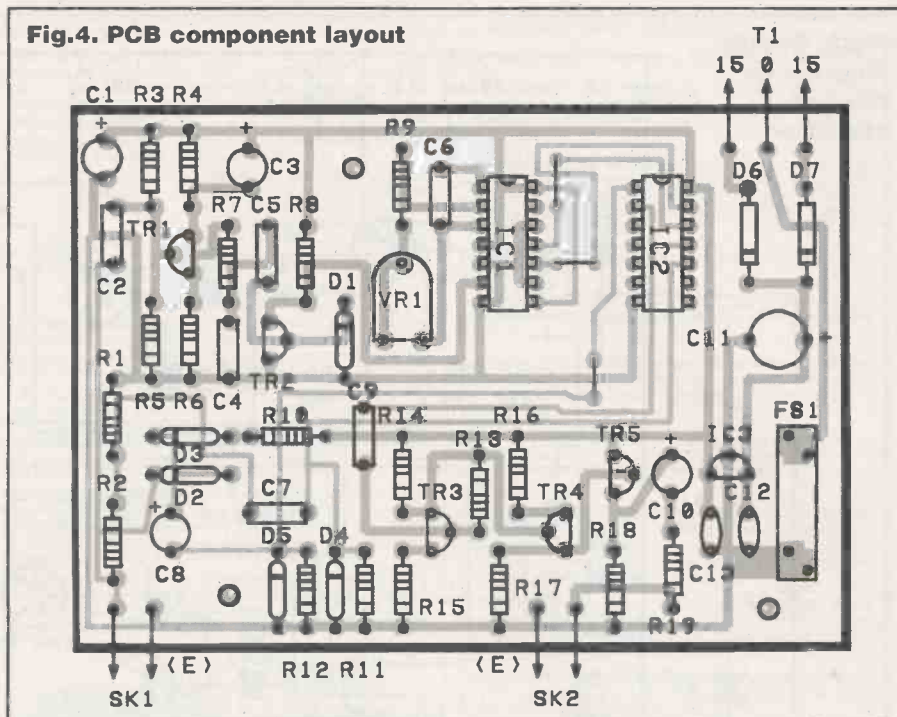

preservation of the synchronisation pulses. The output of this circuit feeds into another standard dc restoration circuit and then into its section of the electronic switch.

TR1 operates in the clipping amplifier at the input of the frame synchronisation filter circuit. This is followed by a simple single pole lowpass filter using R7 and C4. C5 couples the filtered pulses to the clipping amplifier based on TR2. This drives the input of the monostable, which is a negative edge triggered circuit based on a cmos 4047BE astable/monostable (IC1). The output pulse duration is set by C6, R9, and VR1. The latter gives an adjustment range of approximately 0.12ms to about 2.7ms. This enables the unit to blank a large number of lines at the top of the screen, and in practice VR1 is adjusted so that the main picture signal is not significantly affected. Only the unused lines need to be suppressed. As explained previously, the

monostable has Q and not-Q outputs which provide the anti-phase control signals needed by the electronic switch.

A reasonably smooth and stable 12 volt supply is needed, and this is provided by a simple mains power supply circuit. This has push-pull rectification and a small monolithic voltage regulator (IC3) to give a well smoothed output. The current consumption of the main circuit is only about 15 milliamps, and a small voltage regulator is well able to handle this.

CONSTRUCTION

Most of the components fit on to the printed circuit board, details of which are shown in Fig.4. Both the diode integrated circuits are cmos types, and consequently require the normal anti-static handling precautions to be observed. Pin 3 of the

Fig.5. PCB track layout

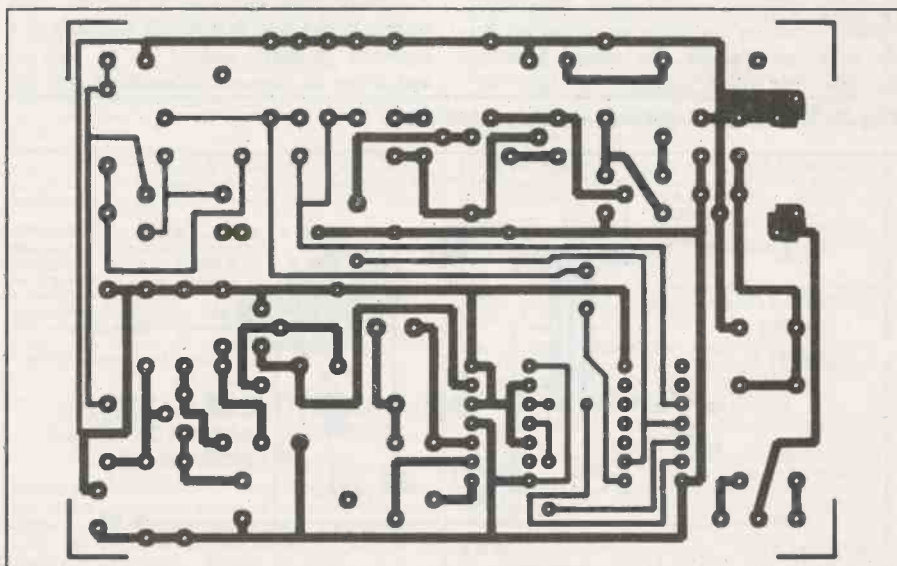



4047BE apparently has no static protection circuit, and this device therefore needs to be handled with extra care. Sockets should be used for both devices, but they should not be fitted into the holders until the board and all the wiring have been completed. Until then they should be left in their anti-static

packaging. The cmos 4066BE analogue switch can be used in place of the 4016BE in most circuits, and both devices seem to work perfectly well in this circuit.

The fuse is mounted on the board via a pair or 20 millimetre fuse-clips. It is advisable to use an anti-surge fuse rather than the more usual "quick-blow" variety. Otherwise there is a strong risk that the fuse will "blow" each time the unit is switched on, due to the large initial charge current into C11. Note that the capacitors are all printed circuit mounting types, and that the "axial" variety might not fit into the layout very well. It is advisable to use polyester capacitors of the correct (7.5 millimetre) pitch, as types having a different pitch could easily be damaged if you try to persuade them to fit on to this board. Fit pins to the board at the points where connections to off-board components will be made, and do not overlook the three link wires.

A metal instrument case having dimensions of about 150 by 100 by 50 millimetres will accommodate all the components, and there are several cases of about this size to choose from. Note though, that as this is a mains powered project the case must be a type that can only be opened with the aid of a screwdriver or other tool. Types with "clip-on" panels or covers are unsuitable for safety reasons. The on/off switch is mounted well towards the right hand end of the front panel, with the two sockets fitted to its left. I used phono sockets for both SK1 and SK2, but these can obviously be any type that will match your video equipment. A hole for the mains lead must be drilled in the rear panel, well towards the left hand end of the panel (as viewed from the rear). This hole should be fitted with a grommet to protect the cable.

The printed circuit board is mounted on the base panel of the case, with the usual stand-offs or spacers being used to hold the underside of the board clear of the metal casing. Mount the board as far to the left of the unit as possible so that there is sufficient space left for the mains transformer to fit to its right. You will probably have difficulty in obtaining a 15 - 0 - 15 volt mains transformer, but a twin 15 volt type should be readily obtainable and is perfectly suitable. It should be connected in the manner shown in the wiring diagram of Fig.6. The transformer

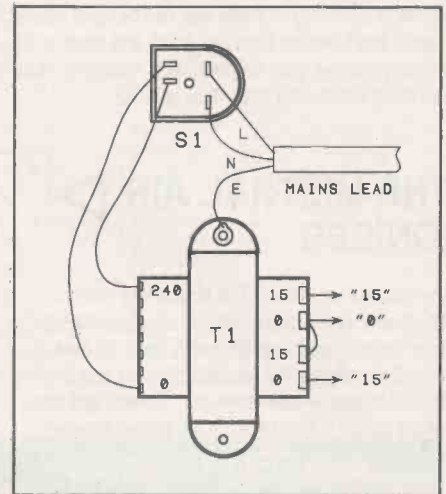

Fig.6. Power supply wiring

only needs to have a secondary current rating of about 50 milliamps, but the smallest type you are likely to find is one having a 100 to 200 milliamp rating. A type having a higher rating is quite suitable provided there is sufficient space for it in the case (I had no difficulty in using a 200 milliamp type). The metal case of the unit must (for safety reasons) be earthed to the mains earth lead. A soldertag on one of T1's mounting bolts provides a convenient way of making this connection.

ADJUSTMENT

With the unit switched on and connected between a video source and a monitor, the picture should appear on the monitor with no significant change in picture quality being apparent. By adjusting VR1 you should be able to blank a small section at the top of the screen, and vary the amount of the picture that is blanked. Simply adjust VR1 to blank as much of the screen as possible without removing any of the main picture lines.

The value of R10 controls the degree of blanking in the top part of the picture. The specified value should be perfectly satisfactory, but if necessary you can obtain more complete blanking by using a higher value here, or a stronger synchronisation signal (but with lower attenuation of the video modulation signal) by using a somewhat lower value.

PE

COMPONENTS

RESISTORS

R1	100
R2	330
R3, R5	33k (2 off)
R4	22k
R6	5k6
R7	10k
R8	3k9
R9, R16	2k2 (2 off)
R10	680k
R11	100k
R12	2k7
R13	3M3
R14, R15, R17	4k7 (3 off)
R18	390
R19	68

All 0.25 watt 5% carbon

POTENTIOMETER

VR1	47k sub-min hor preset
-----	------------------------

CAPACITORS

C1, C10	100µ 16V radial elect (2 off)
C2	470n polyester 7.5mm pitch
C3	22µ 16V radial elect
C4	15n polyester 7.5mm pitch
C5	1n polyester 7.5mm pitch
C6	22n polyester 7.5mm pitch
C7, C9	330n polyester 7.5mm pitch (2 off)
C8	10µ 25V radial elect
C11	1000µ 25V radial elect
C12, C13	100n ceramic (2 off)

SEMICONDUCTORS

IC1	4047BE
IC2	4016BE
IC3	uA78L12
TR1, TR4	BC559 (2 off)
TR2, TR3, TR5	BC549 (3 off)
D1 to D5	1N4148 (5 off)
D6, D7	1N4002 (2 off)

MISCELLANEOUS

SK1, SK2	Phono socket (2 off)
T1	15 - 0 - 15 volt 100mA mains transformer (see text)
FS1	100mA 20mm anti-surge
S1	Rotary mains switch

Printed circuit board, instrument case about 150 x 100 x 50mm, pair of 20mm fuseclips, 14pin dil ic holder (2 off), control knob, mains lead and plug, wire, solder, pins, etc.

Interior view of unit housing showing positioning of pcb and transformer.

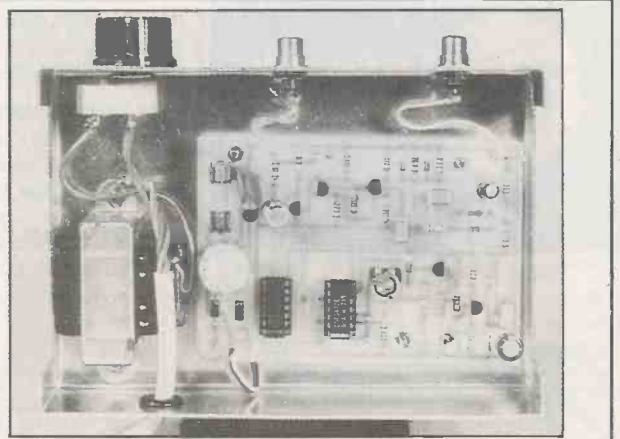

AIR IONISERS

By means of points raised to a very high voltage, ionisers re-structure the air you breathe, turning ordinary air molecules into potent negative ions. The effects of breathing in these ions can be quite startling. Almost everybody reports that it makes them feel good, and there is now strong evidence that it can also improve your concentration, make you more healthy and alert, make you sleep better, and even raise your IQ.

THE MISTRAL AIR IONISER

The ultimate air ioniser. The Mistral has variable ion drive, built-in ion counter and enough power to drive five multi-point emitters with ease. Its nine main drive stages, five secondary drives and four booster stages give an immense 15 billion ions per minute output – enough to fill the largest room in a matter of seconds.

The parts set contains everything you need to build the Mistral: components, PCB, case, emitter and full instructions. If you're keen to increase the output still further, there's an optional eight-point internal emitter set to give extra ionising capability, and an almost silent piezo-electric ion fan to drive the ions away from the emitter and into the room.

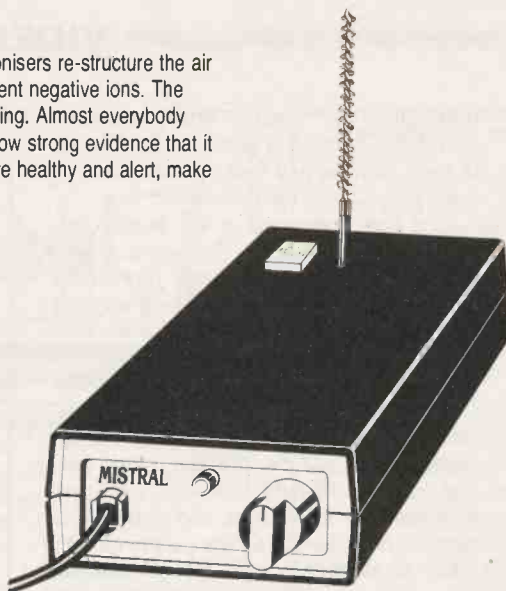

MISTRAL IONISER PARTS SET £32.66

INTERNAL EMITTER PARTS SET (optional) £3.22

ION FAN (optional) £11.27

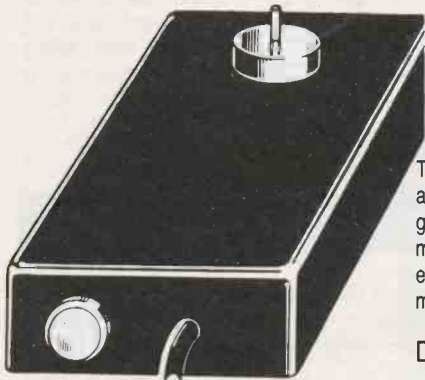

THE DIRECT-ION

The ideal bedside ioniser. If you're keen to see what all the fuss is about, and to experience the ion effect for yourself, this is the one to go for. The Direct-ion parts set contains PCB, 66 components, case, mains lead, and even the components for the tester. Don't forget the experiments: there's the smoke trick, triffids, the living emitter, and more. And full constructional details too, of course.

DIRECT-ION PARTS SET £14.72

THE Q-ION

Check out the ion levels around your house. The Q-ion will measure the output of any ioniser, test the air to see where the ions are concentrating, help you set up fans and position your ioniser for best effect, and generally tell you anything you want to know about ion levels in the air. The readout is in the form of a bar graph which moves up and down as the Q-ion sniffs the air in different parts of the room. Readings up to 10^{10} ions per second, positive or negative.

Q-ION COMPLETE PARTS SET £21.16

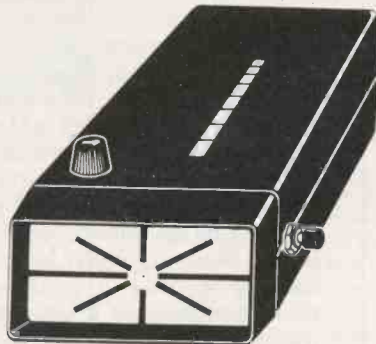

KIRLIAN CAMERA

Bioplasmic fields, auras, or just plain corona discharge? No matter how you explain them, the effects are strange and spectacular. Can you really photograph the missing portion of a torn leaf? Can you really see energy radiating from your finger tips? Most researchers would answer 'yes' to both questions.

Our Kirlian photography set contains everything you need to turn the Mistral into a Kirlian camera, your bedroom or spare room into a darkroom, and to expose, develop and print Kirlian photographs (photographs made with high voltage electricity instead of light). The set includes exposure bed, safelight bulb, developing and fixing chemicals, trays, imaging paper and full instructions. A Mistral ioniser parts set is also required.

KIRLIAN CAMERA SET £19.78

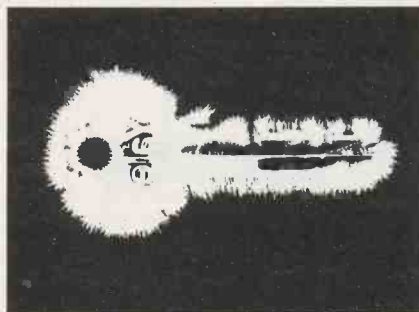

IONISER EXPERIMENTS

* The Vanishing Smoke Trick

Light up a cigarette and gently puff smoke into a glass jar until the air inside is a thick, grey smog. Carefully invert the jar over the ioniser so that the emitter is inside. Within seconds the smoke will vanish! This is one of the best demonstrations of an ioniser's air cleaning action and with a large jar the effect is quite dramatic.

* Triffids

Connect a length of wire from the ioniser emitter to the soil in the pot of a houseplant. One with sharp, pointy leaves is best. Hold your hand close to the plant and the leaves will reach out to touch you! In the dark you may see a faint blue glow around the leaf tips – this works better with some plants than with others, so try several different types. The plants don't object to this treatment at all, by the way, and often seem to thrive on it.

* The Electric Handshake

Wear rubber soled shoes. Touch the ioniser emitter for a few seconds until your body is thoroughly charged up. When your hair stands on end, that's just about enough. Then give everyone you meet a jolly electric handshake. Just think, you could lose all your friends in a single evening! (A meaner trick still is to charge up a glass of water or a pint of beer. Even your family won't speak to you after that!)

Specialist
SEMICONDUCTORS

Tel: (0600) 3715 LIMITED
SALES DEPT., ROOM 108, FOUNDERS HOUSE, REDBROOK, MONMOUTH, GWENT.

ORDERING

All prices include VAT
UK orders: please add £1.15 postage and packing.
Eire and overseas: please deduct VAT and add £5.00 carriage and insurance.



ACCESS

Phone 0600 3715 for immediate attention to your Access order.

The AL80 amplifier module is a popular unit that has been on the market since early 1978. It joined a Bi-Pak range consisting of the AL30 and AL60, 10 and 25-watt units which had been going for some years previously.

There was nothing fancy about the design from the hi-fi viewpoint, and there was no output limiting or short-circuit protection; the circuit was just a straightforward fairly conventional power amplifier. It delivered 35-watts rms into a range of impedances from 16 ohms down to 3 ohms, and operated at single-pole supply voltages from 40-60V, with a below 0.1% harmonic distortion rating (typically 0.06%).

Lower powers were obtained with the lower supply voltages and higher output impedance loads; the output could thus be tailored for the intended use. The maximum rating of 35 watts was sufficient to enable the module to be used for a wide range of applications, and the impedance range added to its versatility.

Apart from these, a major attraction for amateur constructions and professional custom-built equipment alike was its size. It was just 4 inches by 2.5 inches including a flat metal plate which served as a heat sink. For power requirements below 10 watts, no

Technology resolutely marches on, but old-time favourites need not be trodden down to dust, as Vivian Capel proves.

The device was thus contact-cooled in contrast with most power chips and modules that are air-cooled and so need to be mounted outside the equipment casing to ensure an adequate air flow. This was a big advantage which simplified construction, and combined with its small size made the module an ideal choice for many custom-built systems.

Public address amplifiers for small halls is one application for which many AL80s have been used. In fact many thousands of these modules have been produced and installed in a wide range of equipment in the years since their introduction.

The more observant readers will have

hoped some manufacturer will fill before very long), this creates a problem for those having AL80s in use that have developed faults or may do in the future.

Although they are repairable, there has up till now been no published circuit diagram, service information or parts list. The hitherto ready availability of the modules, their moderate cost and the ease of fitting, has meant that replacing and discarding the defective module has been the most practical course when a fault occurred.

The following information has thus been prepared and is presented to aid the repair and servicing of faulty modules.

CIRCUIT DESCRIPTION

The input is via C2 to the base of TR1 which is a pnp device connected across the output circuit that is at half-supply voltage, and earth. Its supply is thereby modulated with the output voltage so providing negative feedback. Capacitors C3 across the input and C6 limit the hf response to prevent hf oscillation. The base bias is decoupled by R1 and C4.

REPAIRING THE AL80

other heat sinking was needed, but for the maximum 35 watts, the plate had to be bolted on to a 16 swg aluminium sheet of at least 45 square inches. Bolting it to a metal chassis or equipment case gave ample heat-sinking in most cases.

noticed that I have been using the past tense in this description. The reason is that, unfortunately, the makers have ceased trading, and the units are no longer available. Apart from a gap in the range of power units available for custom-building, (which it is

The output from TR1 is directly coupled to TR2 which is a npn transistor configured as an emitter follower. It thus has a gain of less than unity, but gives a good drive current to TR3 across which C10 gives further hf limiting.

TR3 drives the bases of the power driver transistors TR5 and TR6. These are a complementary pair that are connected in series across the supply via their emitter and collector resistors. The current through them and hence also through the output pair to which they are directly coupled, depends on the potential difference between their bases. This is regulated by TR4 which is mounted on the heat sink. Any increase in temperature, increases its current which reduces the potential difference between the bases of TR5 and TR6, thereby reducing their current and the current through the output pair.

So there is a degree of long-term self-regulation, with heat sink temperature rises reducing output current. This does not protect against heavy overloads such as when the output is short-circuited, as then the output devices could be destroyed before the heat-sink temperature rose significantly.

The output pair are not complementary but are both npn transistors. They have no emitter resistors, and the output capacitor is not included. This is omitted to save space

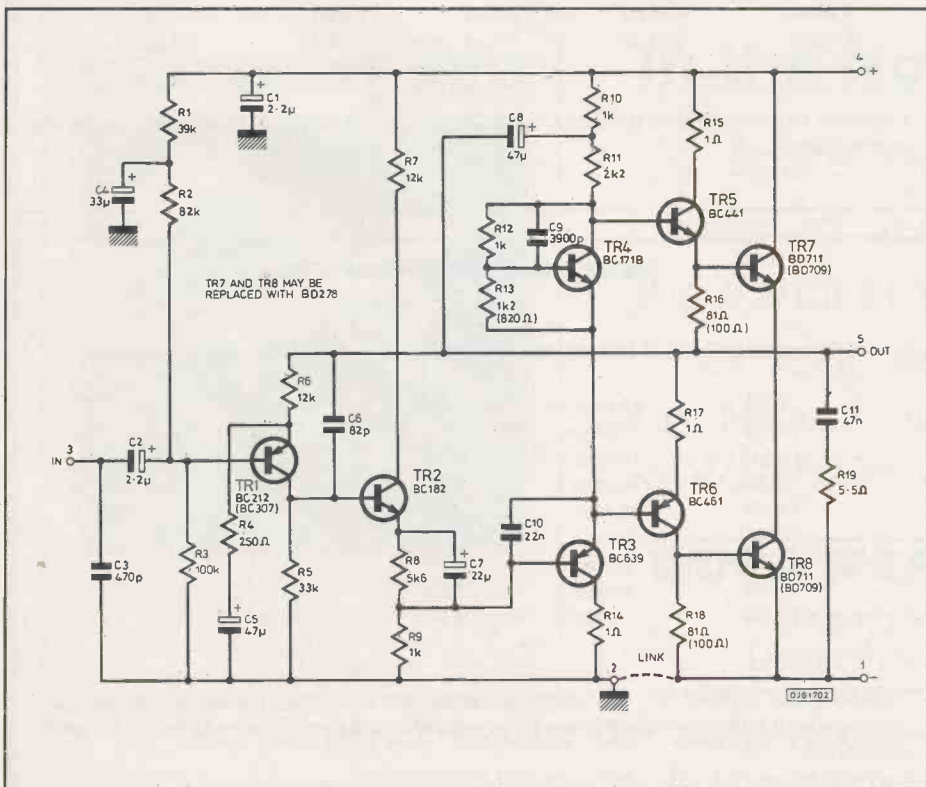

Left: Circuit diagram of the AL80 amplifier module.

MATCHED PAIRS

If possible, try to get a matched pair for output and drivers. Some suppliers will match up a pair though unfortunately most will not. If you have a transistor tester that measures H_{fe} (and such an instrument is very useful for all serious work involving transistors), it is worth buying two or even three pairs of each, and getting the closest match possible. Often a couple of reasonably matched pairs can thus be achieved, thereby providing a back-up pair for the future. At least a grossly mismatched pair will be avoided.

As with all directly-coupled amplifiers, systematic stage-by-stage fault-finding is not feasible because a fault in one stage can upset the dc working conditions in all the other stages, so all can thus exhibit fault symptoms. Transistors are the most likely culprits followed by electrolytic capacitors. Whatever the fault then, the best plan is to remove each transistor in turn and test it. Testing in situ can be misleading due to the presence of shunt circuits.

In the case of a s/c output pair, check the impedance of the load. If it seems to be high enough, that is over 3 ohms, the fault could be due to an earlier transistor failure. Should TR4 go o/c for example, the forward bias through the drivers is

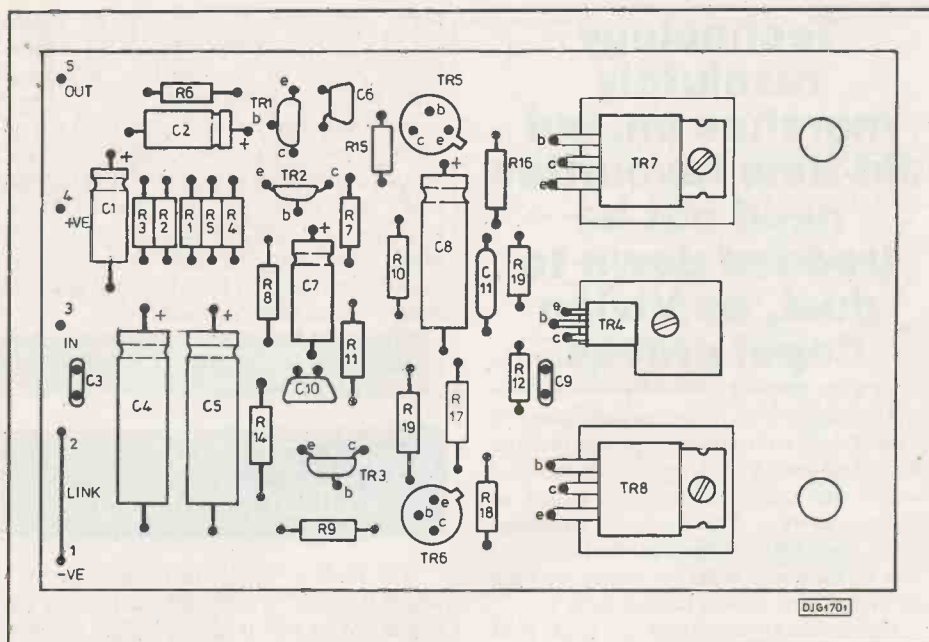

Component layout on the AL80 printed circuit board.

on the panel and usually can be easily accommodated as an axial component wired between the output on the module and the output socket on the amplifier. In addition, the value can thus be selected to suit the load.

C11 and R19 provide further hf roll-off to complement the capacitors fitted in earlier stages.

along with the 1 ohm emitter resistors. A snag here is that BD709 or BD711 transistors, both of which have been used for the output in the AL80, are not generally available. A suitable substitute which requires no circuit changes is the BD278. The BC441 and BC461 drivers and all the other transistors should be no problem to obtain.

FAULTS

The unit has proved to be reliable with few faults developing. This no doubt is partly due to its uncomplicated design consisting of just eight transistors and eleven capacitors of which only six are electrolytics. Most of the troubles that have occurred have been due to external causes such as overloading the output stage. When used as a public-address amplifier, this is likely due to non-technical persons adding extra speakers thereby reducing the load impedance below the minimum specified.

When this happens, as there is no overload protection, the output transistors object and finally go s/c. The visible effect is that the two resistors R15 and R17 disintegrate in a puff of smoke. On examination of the circuit though, it can be seen that these are not in the output stage at all but are the emitter resistors of the drivers. So why should they go?

The answer is because when the output transistors go short-circuit, the drivers start feeding the load through the s/c output devices, and behave as if they were the output transistors. Of course, they are not man enough to feed a load that higher-powered output transistors couldn't manage so they too go s/c. Hence the burnt-out emitter resistors. (Moral: never get ideas above your station.)

The repair thus involves replacing both the output pair and the driver transistors

OUTPUT CAPACITOR VALUES

Output load	20 Hz	40 Hz	60 Hz	80 Hz
3-4 ohms	1,000 μ F	470 μ F	330 μ F	220 μ F
8 ohms	470 μ F	220 μ F	150 μ F	100 μ F
16 ohms	220 μ F	100 μ F	68 μ F	47 μ F

Capacitor values to nearest preferred value, to give ± 2 dB response to indicated frequency at given loads.

HEAT SINK REQUIREMENTS

Output power	Load Impedance	Supply Voltage	Heat Sink Area
7.5W	16 ohm	35V	8 in ²
10.0W	16 ohm	40V	10 in ²
12.5W	16 ohm	45V	20 in ²
15.0W	8 ohm	35V	15 in ²
17.5W	16 ohm	55V	35 in ²
20.0W	8 ohm	40V	20 in ²
25.0W	8 ohm	45V	30 in ²
35.0W	8 ohm	55V	45 in ²
37.5W	3 ohm	35V	40 in ²

Heat sink area depends not only on output power but on supply voltage too because this governs the quiescent current through the output transistors. Heat sink is of 16 gauge aluminium.



increased thereby increasing their current, and thus also the current through the output stage.

ELECTROLYTICS

If no fault is found with any of the transistors, next, check the electrolytics. All have voltages across them, so check for these. The absence of a reading suggests a s/c capacitor, but measure the associated resistors before replacing it in case one has gone o/c. If there are voltages across the capacitors, bridge a replacement across each in turn, remembering to observe polarity. If this clears the fault, the capacitor is o/c.

GENERAL

When two modules are used at high power, such as a stereo pair or a separate speaker and hearing-aid loop supply in a public-address system, ensure that there is adequate heat sinking. It should be double that of a single module. If the chassis area is less than the required amount, extra sinking can be obtained by mounting the modules on an aluminium strip or bar which itself is bolted to the chassis. (A suitable offset may be obtained from an aluminium window maker.) The bar will also lift the print board clear of the chassis and so prevent the possibility of any part shorting to the chassis. If the clearance is small, the chassis area

under the print should be covered with plastic tape.

As much as possible of the integral heat sink should be in contact with the chassis or bar. It should not be supported on nuts and washers on the fixing bolts in order to give chassis clearance. A little heat-sink paste smeared between the module and the bar, and the bar and the chassis will help to increase heat conductivity.

The negative of the output and driver stages is isolated from that of the rest of the circuit on the board, possibly to enable a quick check of the quiescent current, and also permit the earlier stages to be powered for testing without running the output stage. The two, (points 1 and 2 on the board), should be linked for normal use. **PE**

FANG-TASTIC

My dentist tells me he can spot electrical or electronic engineers in any crowd - by the strange slots worn in their teeth! Fangs, he observes, should not be used as wire-strippers! No doubt manicurists could make a similar observation regarding finger-nails. Hands up and open mouths all those who dare to say you're not guilty.

I can't, for one! What else are nature's natural tools for, if not for wire-stripping? Well, years ago I did invest twenty or thirty quid on a sophisticated stripper (!) but it broke eventually, and I never got round to replacing it. Until now.

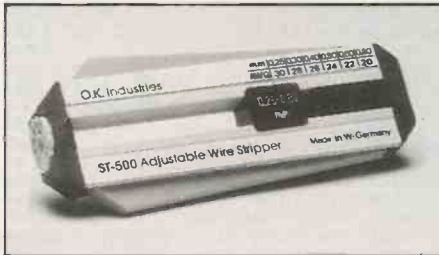

In the post came a news release from OK Industries. "OK's new ST-500 adjustable wire stripper", said the first paragraph, "is a precision tool which quickly and accurately strips 20-30 awg (0.25 to 0.8mm) wire, its hardened blades tackling all types of wire insulation, including Teflon."

So I rang Mr Dorman at OK and corralled him into sending me a free sample to try out. Which I have. Yes, as news release para two says, it's "effortless to use and easy to set up, and the lightweight, squeeze action tool has an adjustable wire stop to ensure consistent strip lengths."

If it weren't already too late, my dentist would be delighted, but for me fangs ain't what they used to be. There's new hope for the claws though!

You could save your gnashers and nails (for about a tanner) by contacting Mr J. Dorman at **OK Industries UK Ltd**, Barton Farm Industrial Estate, Chickenhall Lane, Eastleigh, Hants, SO5 5RR. Tel: 0703 619841.

CRICKLEWOOD ELECTRONICS

OUT NOW!

1989 100 PAGE COMPONENT CATALOGUE PRICE £1

SEND OFF FOR YOUR COPY TODAY...

- WE STOCK AN UNRIVALLED RANGE
- ALL OUR COMPONENTS ARE FIRST CLASS BRANDED ITEMS
- WE OFFER A SAME DAY SERVICE ON ALL STOCK ITEMS
- NO MINIMUM ORDER—IF YOU NEED ONE COMPONENT WE CAN SUPPLY ONE COMPONENT
- WE HAVE ADOPTED A NEW LOWER PRICING POLICY + QUANTITY DISCOUNTS
- FREE VOUCHERS WITH YOUR CATALOGUE—ORDER ONE NOW!...

JUST FILL IN THE COUPON OPPOSITE AND POST IT WITH YOUR £1 PAYMENT TO THE ADDRESS BELOW. YOU WILL RECEIVE NOT ONLY OUR SUPERB 100 PAGE CATALOGUE, BUT ALSO FREE VOUCHERS WHICH YOU CAN USE ON YOUR NEXT COMPONENTS ORDER.

CRICKLEWOOD ELECTRONICS LTD 40 CRICKLEWOOD BROADWAY LONDON NW2 3ET TEL: 01-450 0965/452 0161 FAX: 01-208 1441 TELEX: 914977

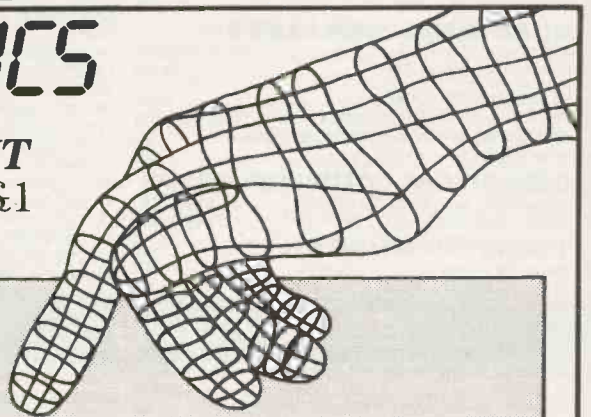

FREE VOUCHERS!

SEND OFF FOR YOUR CATALOGUE AND VOUCHERS TODAY.

I WOULD LIKE TO RECEIVE..... COPY(COPIES) OF THE 1989 CRICKLEWOOD ELECTRONICS COMPONENT CATALOGUE. I ENCLOSE £..... PLEASE ENCLOSE MY FREE VOUCHERS.

Tape your £1 coin here, or send a cheque or postal order for £1.00 for every catalogue you require.

NAME.....
 ADDRESS.....



ELMASET INSTRUMENT CASE

300 x 133 x 217mm deep £10 ea (£2.20)

REGULATORS

LM317T PLASTIC TO220 variable £1
LM317 METAL £2.20
7812 METAL 12V 1A £1
7805/12/15/24V plastic 35p 100+20p 1000+ 15p
7905/12/15/24 plastic 35p 100+20p 1000+ 15p
CA3085 TO99 variable reg 2/£1
LM338 5A VARIABLE £5

COMPUTER ICs

BBC MICRO PARTS
VIDEO ULA 201647 £10ea 10+ £8
6845 CRT £5
6522 PIA £3
DM88LS120 £4.50
AV310150 UART £2.50
IM6402 UART £3
8086 processor equipment £2
USED 41256-15 £3.00
USED 4164-15 ex-equipment £1
9 x 41256-15 SIMM MODULE NEW £25
8 x 4164 SIP MODULE NEW £8
HD 146818 CLOCK IC £2
2864 EEPROM £3
12728A 250ns EPROM USED £2 NEW £2.30
FLOPPY DISC CONTROLLER CHIPS 1771 £10 ea
FLOPPY DISC CONTROLLER CHIPS 1772 £16 ea
68008 PROCESSOR EX-EQPT £5
ALL USED EPROMS ERASED AND BLANK CHECKED
CAN BE PROGRAMMED IF DESIRED.
2716-45 USED £2 100/£1
2732-45 USED £2 100/£1
2764-30 USED £2 100/£1.60
27C256-30 USED £3
27C512 USED £3.50
1702 EPROM EX EQPT £5
2114 EX EQPR 60p 4116 EX EQPT 70p
6264-15 8k static ram £3.50
4416 RAM £3.50
USED 4416-15 RAM £2
USED 41464-15 £7
ZN427E-8 £3.50
ZN428E-8 £3.50

CRYSTAL OSCILLATOR

1.8342 MHz £1 each

CRYSTALS

2.77 MHz/4.000 MHz/4.9152MHz 20MHz 49.504 MHz

TRANSISTORS

BC107, BCY70 PREFORMED LEADS
full spec £1 £4/100 £30/1000
BC557, BC548B 30/£1 £3.50/100

POWER TRANSISTORS

OC35 (Marked CV7084) £1
POWER FET IRF9531 8A 60V 2/£1
2SC1520 sim BF259 3/£1 100/£22
TIP141/2 £1 ea TIP112/125/42B 2/£1
TIP35B TIP35C £1.50
SE9301 100V 10A DARL. SIM TIP121 2/£1
2N3055 EX EQPT TESTED 4/£1
PLASTIC 3055 OR 2955 equiv 50p 100/£35
2N3773 NPN 25A 160V £1.80 10/£16

QUARTZ HALOGEN LAMPS

A1/216 24V 150 WATTS £2.25
H1 12V 50W (CAR SPOT) £1.50

14 WAY AMP ZIF SOCKET

TEXTTOOL single in line 32 way. Can be ganged (coupling supplied) for use with any dual in line devices. 2/£1
14 WAY AMP ZIF SOCKET 2/£1

CAPACITORS COMPUTER GRADE

3300uF 350V SIC SAFCO FELSIC 037 £6(£1.50)
2200uF 160V SIC SAFCO FELSIC CO38 £4(£1.20)

TURNS COUNTING DIALS

all for 0.25" shaft
10 turn dial 21 mm dia. fits 3mm spindle £2
10 turn digital dial (3 digits) for 3mm or 6mm shaft £3.50
10 turn clock face dial for 6mm spindle £4

MISCELLANEOUS

ASSORTED SWITCHES, ROCKER, SLIDE, PUSH .. £2.50
SLOPING FRONT PLASTIC CASE 225 x 215 x 76mm
76 mm WITH ALU FRONT PANEL 200 x 130mm ... £4.00(£1)
HUMIDITY SWITCH ADJUSTABLE £2
WIRE ENDED FUSES 0.25A 30/£1
NEW ULTRASONIC TRANSDUCERS 40kHz £2/pair
12 CORE CABLE 7/0.2mm OVERALL SCREEN. £1/3 metres
POWERFUL SMALL CYLINDRICAL MAGNETS 3/£1
OP AMP LM10CLN £2.90
BNC 50 OHM SCREENED CHASSIS SOCKET 3/£1
BNC TO CROC CLIPS LEAD 1 metre £1
MOULDED INDUCTOR 470µH
size of a 1 watt film resistor 5/£1

TO-220 HEAT SINK sim RS 403-162 10/£2.50

SMALL MICROWAVE DIODES AEI DC1028A 2/£1
D.I.L. SWITCHES 10 WAY £1 8 WAY 80p 4/5/6 WAY ... 50p
180 volt 1 watt ZENERS also 12v & 75v 20/£1
PLASTIC EQUIPMENT CASE 9 x 6 x 1.25 in. WITH FRONT AND REAR PANELS CONTAINING PCB WITH EPROM 2764-30 AND ICS 7417 LS30 LS32 LS74 LS367 LM311 7805 REG. 9 WAY D PLUG, PUSH BUTTON SWITCH, DIN SOCKET £1.90
VN10LM 60v 1/2A 5ohm TO-92 mosfet 4/£1 100/£20
MIN GLASS NEONS 10/£1
RELAY 5v 2 pole changeover looks like RS 355-741 marked STC 47WB05T £1 ea
MINIATURE CO-AX FREE SPLIT RS 456-071 2/£1
MINIATURE CO-AX FREE SKT. RS 456-273 2/£1.50
DIL REED RELAY 2 POLE n/o CONTACTS £1
PCB WITH 2N2646 UNIJUNCTION with 12v 4 POLE RELAY £1
400m 0.5w thick film resistors (yes four hundred megohms) 4/£1
STRAIN GAUGES 40 ohm Foil type polyester backed balco grid alloy £1.50 ea 10+ £1
ELECTRET MICROPHONE INSERT £0.90
Linear Hall effect IC Micro Switch no 613 SS4 sim RS 304-267 £2.50 100+ £1.50

HALL EFFECT IC UGS3040 + MAGNET £1
OSCILLOSCOPE PROBE SWITCHED X1 X10 £10
CHEAP PHONO PLUGS 100/£2 1000/£18
1 pole 12 way rotary switch 4/£1
AUDIO ICS LM380 LM386 £1 ea
555 TIMER 5/£1 741 OP AMP 5/£1
ZN414 AM RADIO CHIP 80p
COAX PLUGS nice ones 4/£1
COAX BACK TO BACK JOINERS 3/£1
4 x 4 MEMBRANE KEYBOARD £1.50
15.000UF 40V £2.50 (£1.25)
INDUCTOR 20uH 1.5A 5/£1
NEW BT PLUG + LEAD £1.50
1.25" PANEL FUSEHOLDERS 3/£1
CHROMED STEEL HINGES 14.5 x 1" OPEN £1 each
12v 1.2w small wire ended lamps fit AUDI VW TR7 SAAB VOLVO 10/£1
12V MES LAMPS 10/£1
STEREO CASSETTE HEAD £2
MONO CASS. HEAD £1 ERASE HEAD 50p
THERMAL CUT OUTS 50 77 85 120°C £1 ea
THERMAL FUSE 121°C 240V 15A 5/£1
TRANSISTOR MOUNTING PADS TO-5/TO-18 £3/1000
TO-3 TRANSISTOR COVERS 10/£1
STICK ON CABINET FEET 30/£1
PCB PINS FIT 0.1" VERO 200/£1
TO-220 micas + bushes 10/50p 100/£2
TO-3 micas + bushes 15/£1
PTFE min screened cable 10m/£1
Large heat shrink sleeving pack £2
CERAMIC FILTERS 6M/9M/10.7M 50p 100/£20
MAINS LEAD WITH MOULDED 13A PLUG AND IEC SOCKET £1.50
IEC chassis plug rfi filler 10A £3
Potentiometers short spindles values 2k5 10k 25k 1m £1
2M5 lin 5/£1
500k lin 500k log 4/£1
40kHz ULTRASONIC TRANSDUCERS EX-EQPT NO DATA £1/pr
PLESSEY INVERTER TRANSFORMER 50 CYCLES
11.5-0-11.5V to 240v 200VA £6 (£3)

DIODES AND RECTIFIERS
1N4148 100/£1.50
1N4004/SD4 1A 300V 100/£3
1N5401 3A 100V 10/£1
BA158 1A 400V fast recovery 100/£3
BA159 1A 1000V fast recovery 100/£4
120V 35A STUD 65p
BY127 1200V 1.2A 10/£1
BY254 800V 3A 8/£1
BY255 1300V 3A 6/£1
6A 100V SIMILAR MR751 4/£1
1A 800V BRIDGE RECTIFIER 4/£1
4A 100V BRIDGE 3/£1
6A 100V BRIDGE 2/£1
8A 200V BRIDGE 2/£1.35
10A 200V BRIDGE £1.50
25A 200V BRIDGE £2 10/£18
25A 400V BRIDGE £2.50 10/£22

SCRs
PULSE TRANSFORMERS 1:1+1 £1.25
MCR72-6 10A 600V SCR 3/£1
35A 600V STUD SCR £1
TICV106D 800mA 400V SCR £2
MEU21 PROG. UNIJUNCTION 3/£1

TRIACS
BT137-600 8A TO-220 2/£1
BT138-600 12A TO-220 70p
NEC TRIAC AC08F 8A 600V TO220 5/£2 100/£30
TXAL225 8A 400V 5mA GATE 2/£1 100/£35
TRAL2230D 30A 400V ISOLATED STUD £4 each

DIACS 4/£1
BT137-600 8A TO-220 2/£1
BT138-600 12A TO-220 70p
NEC TRIAC AC08F 8A 600V TO220 5/£2 100/£30
TXAL225 8A 400V 5mA GATE 2/£1 100/£35
TRAL2230D 30A 400V ISOLATED STUD £4 each

CONNECTORS

D25 IDC SOCKET FUJITSU £2
34 way card edge IDC CONNECTOR (disk drive type) £1.25
CENTRONICS 36 WAY IDC PLUG £2.50
CENTRONICS 36 WAY IDC SKT £4.00
BBC TO CENTRONICS PRINTER LEAD 1.5M £3.50
CENTRONICS 36 WAY PLUG SOLDER TYPE £4
USED CENTRONICS 36W PLUG+SKT £3

USED D CONNECTORS price per pair
D9 60p, D15 £1.50, D25 £2, D37 £2, D50 £3.50 covers 50p ea.

WIRE WOUND RESISTORS

W21 or sim 2.5W 10 of one value £1
R10 OR15 OR22 2R0 4R7 5R0 5R6 8R2 10R 12R 15R 18R 20R 22R 27R 33R 47R 56R 62R 91R 120R 180R 390R 430R 470R 680R 820R 910R 1K1 1K2 1K5 1K8 2K4 2K7 3K3 3K0 5K0 R05 (50 milli-ohm) 1% 3w 4 FOR £1
W22 or sim 6W 7 OF ONE VALUE £1
R47 R62 1R0 1R5 1R8 3R3 6R8 9R1 12R 20R 24R 27R 33R 51R 56R 62R 68R 100R 120R 180R 220R 390R 560R 620R 910R 1K0 1K2 1K5 1K8 2K2 2K7 3K3 3K9 4K7 8K2 10k 15K 16K 20K
W23 or sim 9W 6 OF ONE VALUE £1
R22 R47 1R0 1R1 56R 62R 100R 120R 180R 220R 300R 390R 680R 1K0 1K5 5K1 10K
W24 or sim 12W 4 OF ONE VALUE £1
R50 2R0 3R1 18R 22R 27R 56R 68R 75R 82R 100R 150R 180R 200R 220R 270R 400R 620R 1K0 6K8 8K2 10K 15K

PHOTO DEVICES

SLOTTED OPTO-SWITCH OPCOA OPB815 £1.30
2N5777 50p
TIL81 PHOTO TRANSISTOR £1
TIL38 INFRA RED LED 5/£1
4N25, OP12525 OPTO ISOLATOR 50p
PHOTO DIODE 50p 6/£2
MEL12 (PHOTO DARLINGTON BASE n/c) 50p
RPY58A LDR 50p ORP12 LDR 70p
LEDs RED 3 or 5mm 12/£1 100/£6
LEDs GREEN OR YELLOW 10/£1 100/£6.50
LEDs ASSORTED RD/GN/YW + INFRA/RED 200/£5
FLASHING RED OR GREEN LED 5mm 50p 100/£35

STC NTC BEAD THERMISTORS

G22 220R, G13 1K, G23 2K, G24 20K, G54 50K, G25 200K, G16 1M, RES @ 20°C DIRECTLY HEATED TYPE £1 ea
FS22B NTC BEAD INSIDE END OF 1" GLASS PROBE RES @ 20°C 200R £1 ea
A13 DIRECTLY HEATED BEAD THERMISTOR 1k res. Ideal for audio Wien £2 ea

CERMET MULTI TURN PRESETS 3/4"
10R 20R 100R 200R 250R 500R 2K 2K2 2K5 5K 10K 47K 50K 100K 200K 500K 2M2 50p each

IC SOCKETS

6 pin 15/£1 8 pin 12/£1 14/16 pin 10/£1 18/20 pin 7/£1, 22/24/28 pin 4/£1 40 pin 30p

SOLID STATE RELAYS

40A 250V AC SOLID STATE RELAYS £18

POLYESTER/POLYCARB CAPS

100n 63v 5mm 20/£1 100/£3 1000/£25
1n/3n/5n/6n/8n/20n 1% 63v 10mm 100/£6
10n/15n/22n/33n/47n/68n 10mm rad 100/£3.50
100n 250v radial 10mm 100/£3
100n 600v sprague axial 10/£1 100/£6 (£1)
2u2 160v rad 22mm 100/£10
10n/33n/47n 250v ac x rated 15mm 10/£1
470n 250v ac x rated rad 4/£1
1U 600V MIXED DIELECTRIC 50p ea.

RF BITS

MINIATURE CO-AX 50Ω URM95 100m/£12
12 volt CO-AXIAL relays sim. RS 349-686 £6
Ex-equipment, with BNC tails
TRIMMER CAPS ALL 4/50p
SMALL 5pf 2 pin mounting 5mm centres 4/50p
SMALL MULLARD 2 to 22pF 4/50p
SMALL MULLARD 5 to 50pF 4/50p
larger type grey 2 to 25pF black 15 to 90pf
TRANSISTORS 2N4427 60p
FEED THRU CERAMIC CAPS 1000pF 100/£1

MINIATURE RELAYS

Suitable for RF
5 volt coil 1 pole changeover £1
5 volt coil 2 pole changeover £1
12 volt coil 1 pole changeover £1

MONOLITHIC CERAMIC CAPICITORS

10n 50v 2.5mm 100/£4.50
100n 50v 2.5mm or 5mm 100/£6
100n ax short leads 100/£3
100n ax long leads 100/£6
10n 50v dil package 0.3" rad £4/100 £35/1000
100n 50v dil package 0.3" rad £10/100

STEPPER MOTORS

4 PHASE 2.9V WINDINGS £3.50

KEYTRONICS

TEL. 0279-505543

FAX. 0279-757656

P O BOX 634

BISHOPS STORTFORD

HERTFORDSHIRE CM23 2RX

MAIL ORDER ONLY

MIN CASH ORDER £3.00 OFFICIAL ORDERS WELCOME
UNIVERSITIES COLLEGES SCHOOLS GOVT. DEPARTMENTS
MIN. ACCOUNT ORDER £10.00
P&P AS SHOWN IN BRACKETS (HEAVY) ITEMS
65p OTHERWISE (LIGHT) ITEMS

ADD 15% VAT TO TOTAL
ELECTRONIC COMPONENTS
BOUGHT FOR CASH

In the final parts, we shall examine special refinements to receivers and transmitters, like agc and squelch, as well as expand on previous sections covering detection and amplification.

THE AM RECEIVER

It would be as well to begin with a few definitions.

Sensitivity

This is the weakest signal that can be detected without distortion and is limited by noise produced within the receiver itself. The formal definition of sensitivity is the minimum input carrier voltage required to provide a specified signal to noise ratio at the output of the IF stage.

The signal to noise ratio specified at IF because fm detectors provide an improvement in signal to noise ratio. Another definition applied to am receivers is the minimum input carrier voltage modulated 50% at 1kHz and producing the specified signal to noise ratio at the output of the detector.

Selectivity

The ability of the receiver to tune in the required signal and reject other signals is the selectivity. This depends on the circuits before the detector, mainly filters in the IF stage.

IF rejection

This is the ratio in dB of inputs at IF and the desired carrier to produce equal outputs from the mixer and varies with tuning. For instance an am receiver tuned to 1605kHz will be in a better position to reject an interfering signal at 455kHz than if it were tuned to 555kHz.

Image rejection

The image frequency is given by $f = f_0 + f_{if}$ where f_0 is the oscillator frequency and f_{if} is the IF. When the image frequency is picked up by the aerial and reaches the mixer, it beats with the oscillator. The image rejection in dB is the ratio of f to the required input to produce equal outputs from the mixer. Once again the value varies with tuning and 50dB is typical for a good communications receiver.

RF AND IF STAGES

An rf amplifying stage has many requirements some of which are high power gain and low noise figure, stability and selectivity to prevent spurious, image and IF frequencies reaching the input of the mixer. It should have a linear amplification in order to amplify strong signals without cross modulation distortion (cmd) or intermodulation distortion (imd), and also

isolate the aerial from the mixer and local oscillator.

In active devices like transistors which produce third order distortion when the desired signal and interfering signal are fed to the input, amplitude modulation of the interfering sign can be transferred to the desired signal. This is called cross modulation and occurs when the desired signal is weak and in the adjacent channel to the interfering signal from a stronger transmitter. This can occur in the mixer as well as rf amplifier and fets are often used in both stages.

The local oscillator must be stable so that the receiver's tuning does not drift with voltage or temperature, since the local oscillator frequency decides the sum and difference frequencies at the output of the mixer.

An IF of 455kHz for am and 10.7MHz for fm broadcast were chosen in the days of the vacuum tube since a low IF meant less lead inductance and stray capacitance and therefore higher gain and better stability.

However, this does not help the image rejection since the IF is separated by only 910 kHz from the am broadcast band. For fm (88MHz to 108MHz), the separation between rf and an image frequency is 21.4MHz which is no better than for am, percentage wise.

Although valves are still around, particularly in high power transmitters, the

HF RADIO

Noise figure

This is defined as:

$$\frac{\text{input signal to noise ratio}}{\text{output signal to noise ratio}}$$

For multistages, 5dB to 10dB is typical for a good receiver from the aerial input to the IF output.

Part Five by Mike Saunders

In this last part we look at RF and IF stage design, filters and detectors.

transistor has distinct advantages whenever it is possible to use them. They are smaller, cheaper and give good gain to higher frequencies. They have a lower impedance than vacuum tubes and the stray capacitance is less.

Since they need less power, more stages can be used without increasing the cost significantly. A frequency up conversion in the mixer is also possible for producing a higher IF giving a simpler front end design and better image rejection.

AM receivers are popular right through the frequency range from lf to vhf and the main application is for entertainment broadcast. Since there is a broadcast station in almost every city, the signal is good and an rf stage may not be required.

Fig. 1 shows a simple am tuner without an rf stage and the mixer and local oscillator

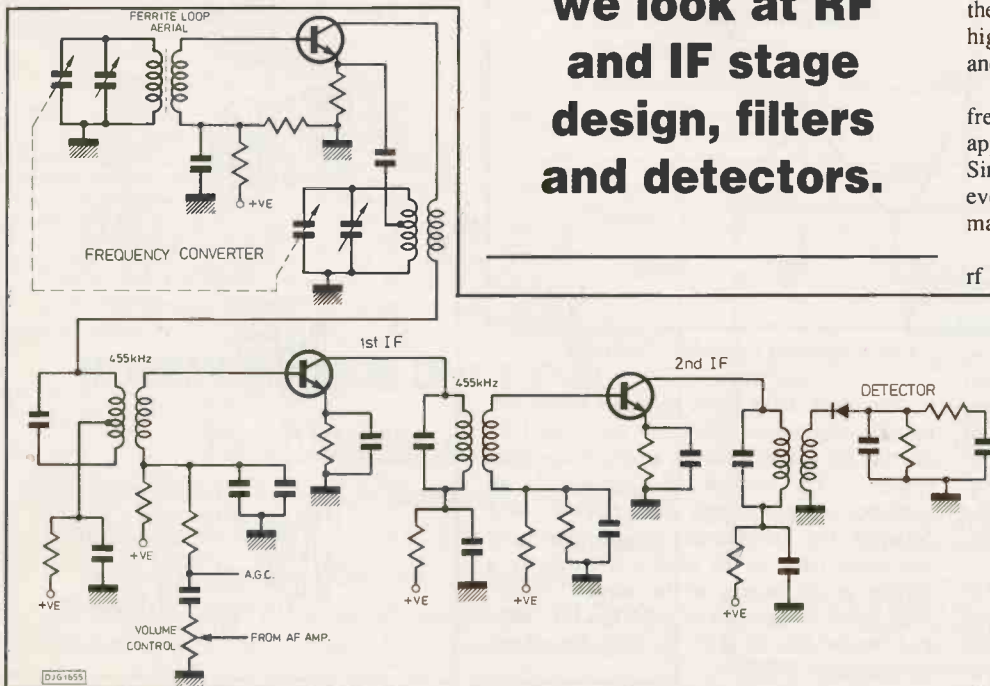

Fig 1.
Simple AM tuner

combined in a stage called a frequency converter. In addition if a diode detector is used, the result is a cheap, lightweight receiver which is portable. The IF filters are single tuned transformers.

If a $10\ \mu\text{V}$ signal is received at the aerial and a 2 volt signal is required at the detector, the gain over all those stages is 106dB. If the IF stages can provide 90dB of gain, then the mixer stage need provide only 16dB. Two to four transistor stages will do the job and if ics are used, two are usually sufficient, one for the rf-IF stages and another for the audio.

FILTERS

If ics are used then transformer coupling is unnecessarily bulky. This led to research into ceramic and saw (surface acoustic wave) filters. These are small, provide a better response than transformer coupling, and require no tuning.

However tuned transformers are still used as IF filters because they are cheap, provide good impedance matching by the use of tapped windings and high attenuation outside the passband. The alternatives are piezoelectric or magnetostrictive filters.

Mechanical filters are made from piezoelectric ceramic or magnetostrictive ferrite. These convert electrical signals into mechanical vibrations which are sent through a mechanical resonator of high Q and a transducer at the output. Such filters are useful at frequencies up to 600kHz with bandwidths of 0.1% to 10% of the centre frequency.

Ceramic filters are made from piezoelectric ceramics with centre frequencies of a few kilohertz to 10.7MHz and bandwidths of 0.05% to 20% of the centre frequency. Fig. 2 shows a ceramic filter, its equivalent circuit and frequency response.

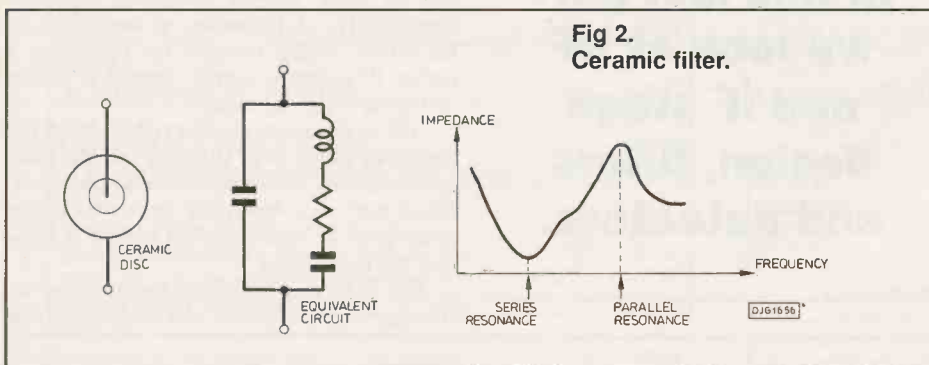

Crystal filters can serve the same purpose as bulky transformers by coupling between pairs of electrodes. Fig. 3 shows a monolithic (simple) quartz crystal filter and equivalent circuit where C is the input and output capacitance, C2 the capacitance of the gap and k is the coupling coefficient between the resonant regions where $k = \text{bandwidth} / \text{resonant frequency}$.

In the fundamental mode the thickness of the wafer is half the wavelength and harmonic nodes occur at odd multiples of half wavelength. Monolithic filters have a high Q

Fig 3. Crystal filter.

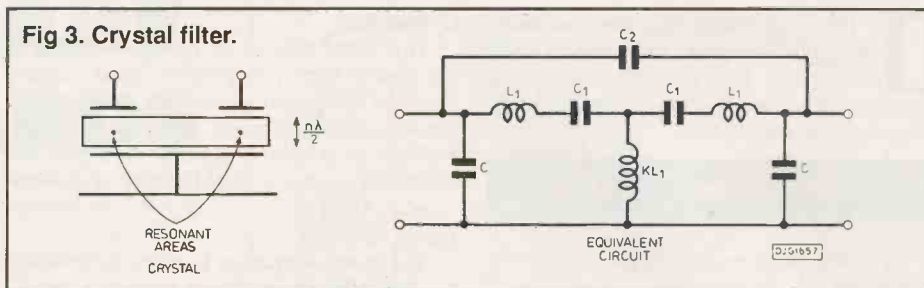

and so the bandwidth is restricted to a few tenths of 1% of the centre frequency. The bandwidth is sufficient for ssb, fm and telephone (4kHz) circuits in the frequency range 5MHz to 350 MHz.

Surface acoustic wave (saw) filters are another means of cutting down on space and weight and are popular in television IF amplifiers. The insertion loss is 10dB to 30dB which is higher than conventional filters but the compensation is a wider bandwidth and better shaping of the band.

Fig. 4 shows the construction of a saw filter. The spacing of the fingers determines the wavelength and the overlap determines the strength of the signal. The number of sections defines the bandwidth approximately as

Fig 4. SAW filter.

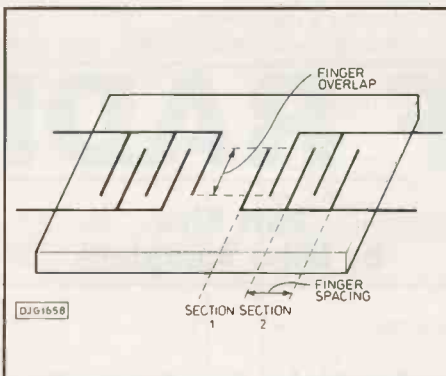

Fig 2. Ceramic filter.

follows: resonant frequency = sections / bandwidth

Therefore delay lines, bandpass filters and pulse compression filters can be created by altering the length, spacing, and overlap of the fingers. The method of operation is an acoustic wave through the electric field between the interleaved fingers which is converted back to an electrical wave by a similar set of fingers at the output. Filters with centre frequencies of 10MHz to 800MHz and bandwidths of 0.3% to 20% have been constructed.

THE DETECTOR

The most common detector for am receiver application is the diode envelope detector, Fig. 5. It is also used for ac-dc conversion in voltmeters and as video detectors in tv receivers since it is simple and the output is fairly linear.

In Fig. 5, the diode conducts near the peak of each cycle charging capacitor C1 to the peak value of each cycle. The diode is reverse biased on the downward slope of each cycle and C1 discharges through R1, Fig. 5b. If C1 is of the wrong value it will be too slow to follow the modulation and clip the waves (Fig. 5c) or if it is too fast it will follow the rf variations more closely, Fig. 5d, producing an excessive ripple in the output.

Since the detector output has a dc component proportional to the modulating audio, it can be used for automatic gain

Fig 5. (a) Diode detector, (b) input and output wave forms, (c) clipped waveform, (d) charge/discharge too fast.

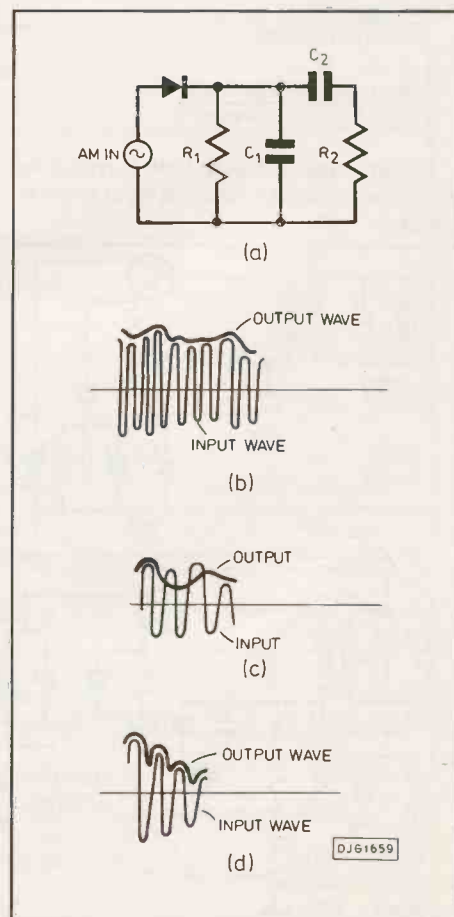



control (agc). In any case it must not be allowed to reach the audio amplifier or it will cause instability by altering the operating point. Capacitor C2 blocks this dc. Another form of detector is the product detector. This is not strictly a detector in that it does not demodulate the signal to its audio component as in the diode detector. It is more in the nature of a mixer in that it accepts dsb or ssb and a local carrier and produces a difference frequency.

With dsb the phase and frequency of the carrier are more critical than for ssb and a pilot some 20db down on the signal is transmitted to synchronise the voltage controlled oscillator (vco) in the receiver's phase locked loop, Fig. 6.

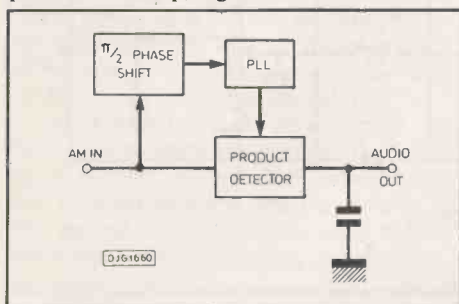
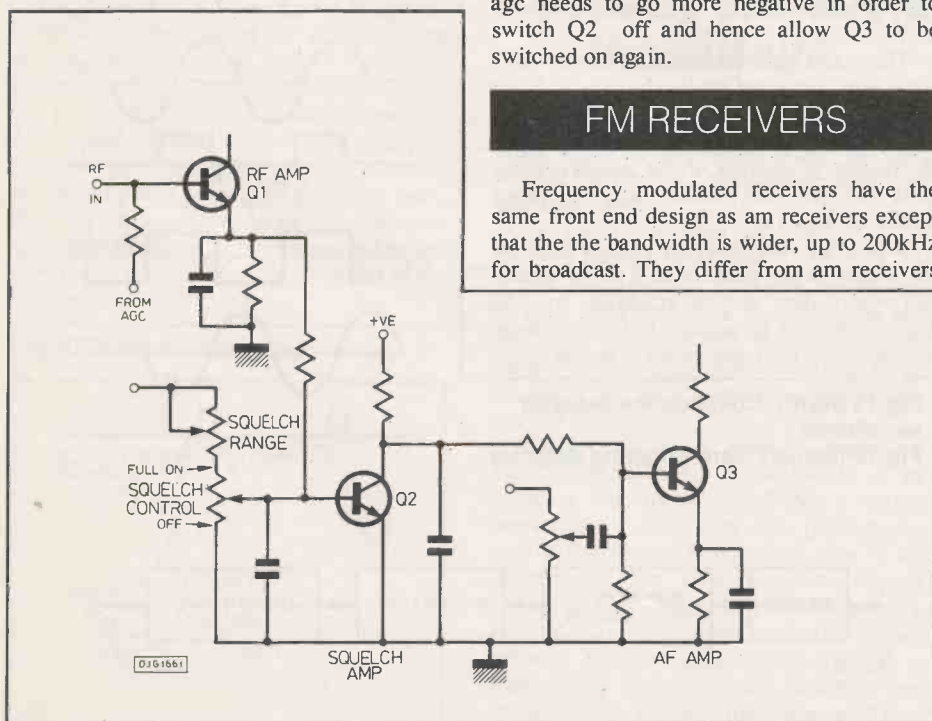

Fig 6. Product detector with PLL.

In dsb operation if the frequency of the carrier is correct but the phase is not, then the amplitude of the audio output is reduced. If the frequency is incorrect or drifting then the upper sideband (usb) and lower sideband (lsb) are different.

Fig. 6 shows a 90° phase shift network since many phase detectors in phase locked loops (pll) require the vco to be 90° out of phase with the incoming signal. The pll provides the required frequency but the audio amplitude can be adjusted for maximum output by adjusting the phase network.

Fig 7. Squelch circuit.



FM RECEIVERS

Frequency modulated receivers have the same front end design as am receivers except that the bandwidth is wider, up to 200kHz for broadcast. They differ from am receivers

Fig 8 (top). FM receiver block diagram.
Fig 9. IF stages of FM receiver.

AGC AND SQUELCH

Automatic gain control (agc) is required because the signal at the aerial of a radio or tv receiver varies greatly as the receiver is tuned from channel to channel. A strong signal would overload the mixer and cause distortion, therefore the gain of the rf stage must be reduced by negative feedback.

Agc is also applied to the IF stage in order that the input to the detector is constant. However, agc is not applied to the mixer since good mixer operation depends on a stable mixer. But agc is used for other purposes such as squelch circuits, tuning meters, S meters.

Squelch circuits are required to bias the first audio stage to cut off until the received signal is strong enough to switch it on with the help of agc. This helps remove background noise which is tiring in channels shared by multi-users such as citizens band (cb) radio.

Fig. 7 shows a simple squelch circuit. The operation of the circuit is a combination of the setting of the squelch control and the strength of the agc voltage. With the squelch control off (base of Q2 earthed), Q3 is switched on, but with the squelch on, Q3 is cut off and the agc needs to go more negative in order to switch Q2 off and hence allow Q3 to be switched on again.

in that they require frequency detectors, amplitude limiters and a larger IF bandwidth.

Although fm receivers are not affected by amplitude induced noise, they are affected by phase distortion. For instance if the phase of the sideband relative to the carrier is not accurate, the modulating signal cannot be recovered properly.

Fig. 8 shows a block diagram of an fm receiver. Most commercial ic packages provide a gain of about 40db and if say 15db is allocated to the rf amplifier and mixer, then 25db is supplied by the IF stage. The ic package incorporating the IF also incorporates the fm detector, and the manufacturer's specification shows the input voltages for a choice of s/n ratio, limiting, audio output, etc.

In order to amplify fm signals without distortion, the transfer function of the IF stage must be linear, ie, the filters and amplifiers must have a characteristic whose phase decreases linearly with frequency. In practice no device is ideal and the next best solution is to use components such that their non-linearities cancel each other.

Fig. 9 shows a block diagram of the IF stages of an fm receiver. Phase distortion would be of less interest to a designer of low quality communications receivers than to a designer of a high fidelity entertainment broadcast receiver.

FM DETECTORS

The basic aim of an fm detector is to produce an output voltage when the input voltage varies in frequency from a reference. The ideal fm detector has a transfer function as shown in Fig. 10. For input frequencies with equal spacing above and below the reference the output voltage has the same

Fig 10. Transfer function of ideal FM detector.

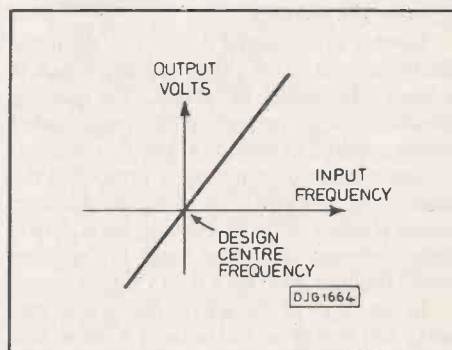

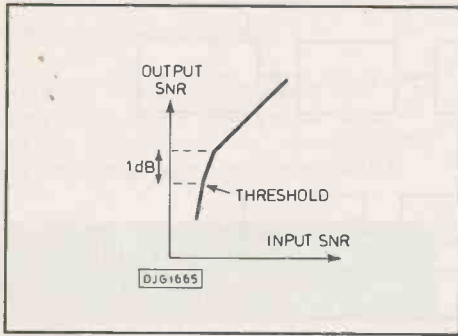

Fig 11. Input/output SNR of FM detector.

amplitude but opposite polarity. Practical detectors are not entirely linear and have voltage and frequency limits.

There is a threshold signal to noise ratio (snr) for each type of detector and modulation index. If the input snr is better than this threshold then the output snr is even better, Fig. 11. This improvement results because one is trading bandwidth for snr ie, the bandwidth of the audio at the detector output is less than the IF at the detector input.

Another way of looking at it is that the signal power in the whole bandwidth contributes towards the output signal power, whereas the noise contribution is from only the limits of the modulating frequency. Above the threshold snr if the modulating index is increased while keeping the highest modulating frequency fixed, the output signal power is increased but the output noise power does not increase.

Raising the modulation index means the detector threshold must be raised or the input snr will fall below this threshold. Below the threshold, the output snr gets better as the IF bandwidth or modulation index is decreased. At present a phase locked loop (pll) is the best available fm detector although low threshold detectors are being developed.

The improvement in snr above the threshold results in a bonus called 'capture' in which the strongest signal is heard and any annoying interference disappears. This is a sharp contrast from am and makes fm the obvious choice for mobile radio where there is not only electrical interference but the radio spectrum is crowded.

The capture ratio is the ratio in db of desired to undesired signal to provide a 30db suppression of the undesired signal. The precise definition is a complex measurement of suppression of one signal generator by another at a number of standard inputs. High fidelity domestic receivers have capture ratios between 1db and 2db.

When a strong signal is received, the noise disappears and this is called quieting which is a direct consequence of capture. The quieting sensitivity of a receiver is the unmodulated carrier required to provide a specific reduction in output noise over the noise present in the absence of a signal. A domestic receiver would produce 30db of quieting for a 1.7µV signal whereas a narrow band fm receiver would produce 20db for a 0.5µV signal.

In the days of the valve, the device was bulky and expensive and because it ran so hot,

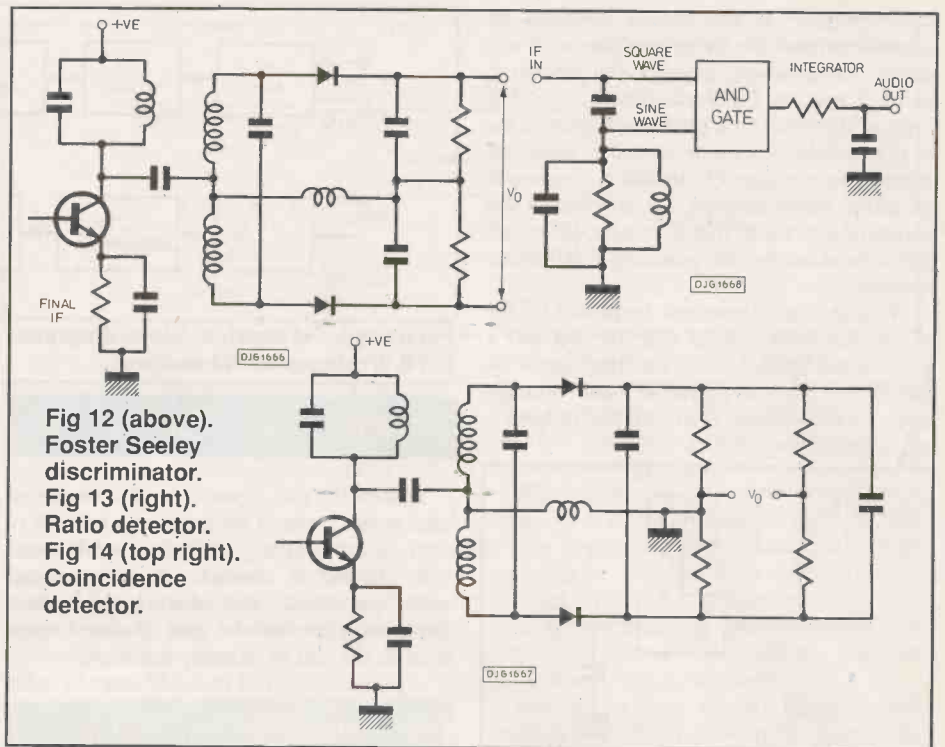

**Fig 12 (above). Foster Seeley discriminator.
Fig 13 (right). Ratio detector.
Fig 14 (top right). Coincidence detector.**

its life was limited. With the invention of the transistor, the Foster-Seeley detector (Fig. 12) was replaced by the ratio detector, Fig. 13. The ratio detector is less sensitive to amplitude variations of the incoming signal. Am rejection is defined as the ratio in decibels of fm detector audio power output for a specific fm input, to the audio power output for a specific am input.

In a coincidence detector, the IF is turned into a square wave by hard limiting to a square wave. The square wave is split and fed to an AND gate Fig. 14. One half is fed directly to the AND gate and the other half through a phase shift network. The phase shift network includes a resonant circuit of high Q and the input to the AND gate is a sine wave whose frequency is the same as the IF mid-frequency.

The AND gate produces an output only when both inputs are positive going. If either input is negative going there is no output. The length of the output pulse will depend on the degree of overlap of the positive going parts of the waveforms, ie, the phase difference, Fig. 15.

When the waveforms are exactly in phase the length of the pulse is half the IF period and when they are in antiphase by 180 degrees, there is no output. In between these two extremes, the pulse varies in length.

The output of the AND gate is fed to an RC integrator whose output will be proportional to the average value of the input pulses and the output of the integrator is therefore a reproduction of the modulating waveform.

After hard limiting the IF, one of the difficulties of fm detection is to decide the instantaneous frequency of the square wave. One method is to use a zero crossing detector and measure the intervals at which the carrier crossed the zero line. Doubling this gives the period T of the wave and the reciprocal 1/T gives the frequency.

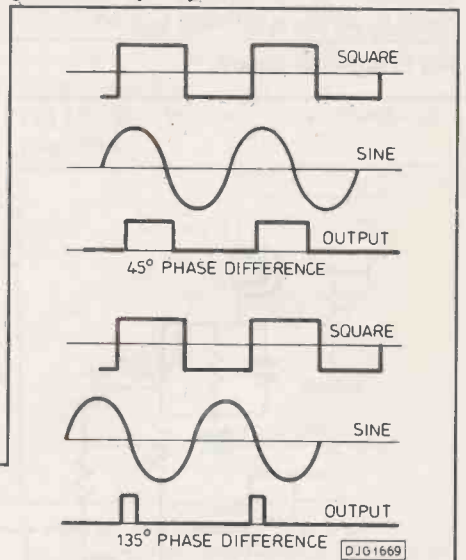

**Fig 15 (right). Coincidence detector waveforms.
Fig 16 (below). Zero crossing detector.**

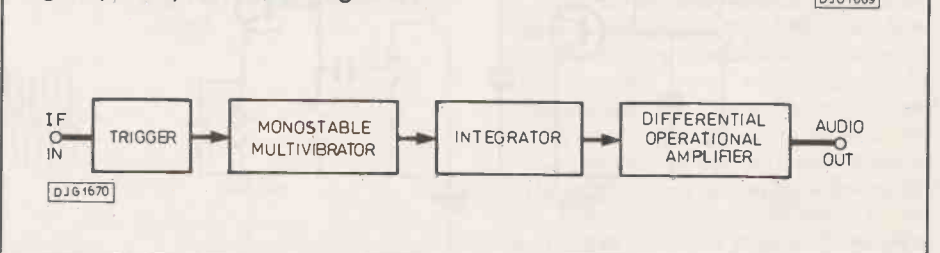



This method is expensive and the output is better than normally required for communications. A simpler method is to use a monostable. The Q and Q outputs, Fig. 16, are applied to RC integrators and then to a differential operational amplifier.

The output of the operational amplifier is the difference between the average values of Q and Q multiplied by a constant. If the input signal frequency drops, the average voltage at Q increases and that at Q decreases making the output of the operational amplifier negative. Similarly the output of the operational amplifier will become positive if the input signal increases in frequency. The result is a linear relationship between the IF deviation and the amplitude output of the operational amplifier.

STEREO RECEPTION

A stereo reception relies on the broadcast of a right (R) and left (L) channel. When stereo records were produced in the 1950s, an attempt was made to also broadcast stereo music. The early attempt was by transmitting one channel on am and the other on fm by those stations which held both licences.

This was not satisfactory and the present method of transmitting both channels on the same fm carrier replaced it. Instead of transmitting the left and right channels, the sum (L + R) and difference (L - R) are transmitted. This is because mono receivers must be able to receive stereo broadcasts without the necessity for modification. Therefore a mono receiver detects the (L + R) signal which is also what a mono transmitter would send out.

The modulating wave of an fm stereo signal is shown in Fig. 17 where the difference signal (L - R) modulated a 38kHz subcarrier to produce a DSB/SC. The sum (L + R) is transmitted in phase with the subcarrier so that the subcarrier oscillator at the receiver can be synchronised with the subcarrier oscillator in the transmitter.

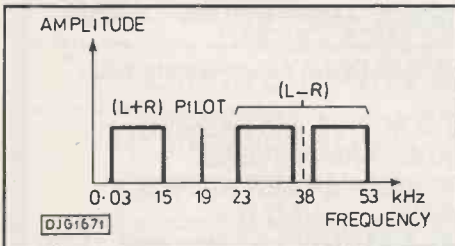

Fig 17. Modulating wave of FM stereo.

A pilot is transmitted instead of the subcarrier because the pilot fits in a slot far removed from the channels whereas the subcarrier is only 30Hz away from the sidebands and therefore requires expensive filters.

An fm stereo receiver adds and subtracts the (L + R) and (L - R) signals in order to obtain the original L and R channels. A mono receiver on the other hand does not expect to see anything above 15kHz therefore the (L + R) signal is accepted and everything else discarded by filtering.

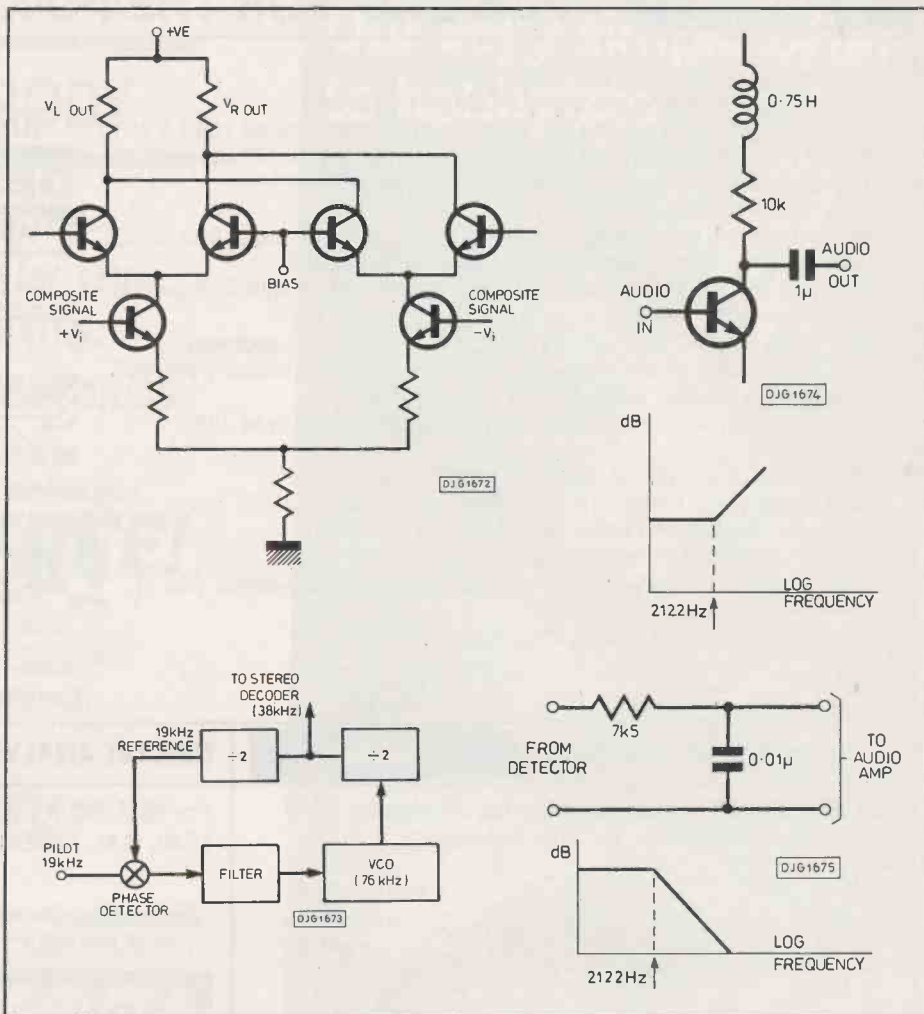

Fig 18 (top left). FM stereo decoder. Fig 19 (bottom left). Generation of subcarrier. Fig 20. (top right). Pre-emphasis. Fig 21 (bottom right). De-emphasis.

A popular form of fm stereo decoding circuit is shown in Fig. 18. The 38kHz subcarrier is usually generated on the same chip by means of a pll, Fig. 19. The 19kHz pilot is applied to a phase detector whose output controls a 76kHz vco which is an RC relaxation oscillator.

A divide by two circuits provides the 38kHz subcarrier and a further divide by two provides a 19kHz for comparison into the phase detector.

During the propagation the higher frequencies get attenuated more than the lower frequencies and therefore they need

extra amplification (pre-emphasis). At the receiver the higher frequencies, above 2122Hz, are de-emphasised.

Pre-emphasis is carried out by a differentiator, as in Fig. 20, consisting essentially of an RL network of time constant 75 µs, and de-emphasis by an integrator (Fig. 21) consisting of an RC network of the same time constant.

Next month we conclude the series by discussing transmitters and converters. PE

A practical method of improving radio reception amplification using a vacuum tube.

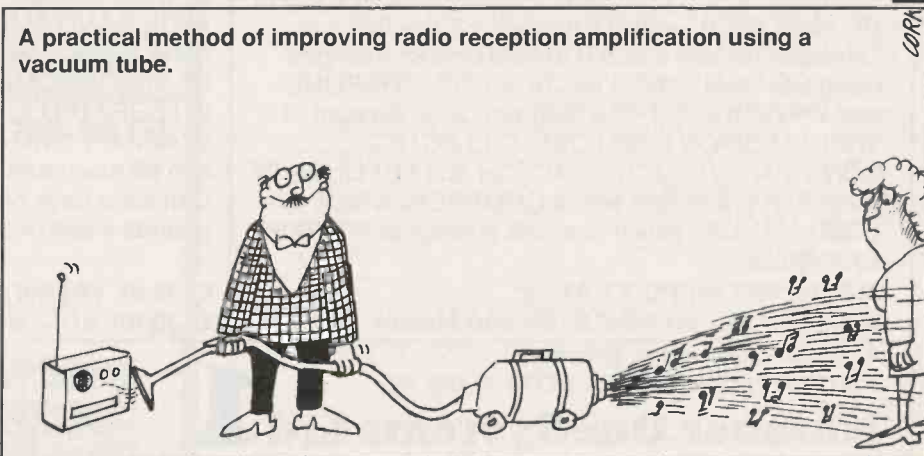

MAKING ELECTRONICS C.A.D. AFFORDABLE

EASY-PC

PCB CAD, FOR THE PC/XT/AT

TINY-PC

- Are you still using tapes and a light box?
- Have you been putting off buying PCB CAD software?
- Have you access to an IBM PC/XT/AT or clone inc Amstrad 1640 & 1512
- Would you like to be able to produce PCB layouts up to 17" square?
- With up to 8 track layers and 2 silk screen layers?
- Plus drill template and solder resist?
- With up to eight different track widths anywhere in the range .002 to .531"
- With up to 16 different pad sizes from the same range?
- With pad shapes including round, oval, square, with or without hole and edge connector fingers?
- With up to 1500 IC's per board, from up to 100 different outlines?
- With auto repeat on tracks or other features – ideal for memory planes?
- That can be used for surface mount components?
- With the ability to locate components and pads on grid or to .002" resolution?
- With an optional auto via facility for multilayer boards?
- With the ability to create and save your own symbols?
- That can be used with either cursor keys or mouse?
- That is as good at circuit diagrams as it is a PCB's?
- That outputs to Dot Matrix Printer, Pen-Plotter or photo-plotter (via bureaux)?
- Where you can learn how to use it in around an hour?

**BRITISH
DESIGN
AWARD
1989**

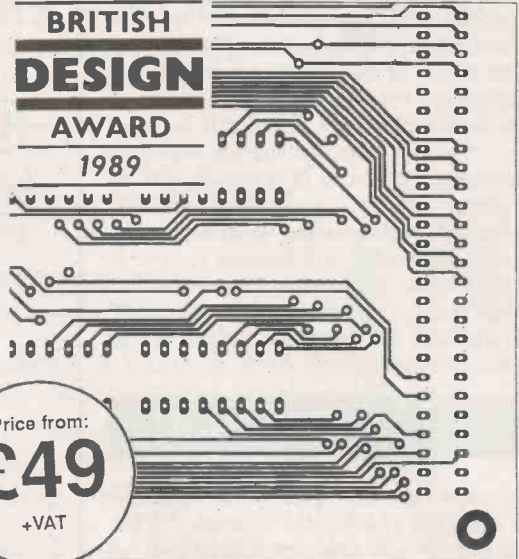

Price from:
£49
+VAT

Excellent quality from dot matrix printer

SMITH CHART PROGRAM – Z-MATCH

For IBM, PC/XT/AT and clones inc. Amstrad 1512 and 1640 and BBC B, B+ and Master.

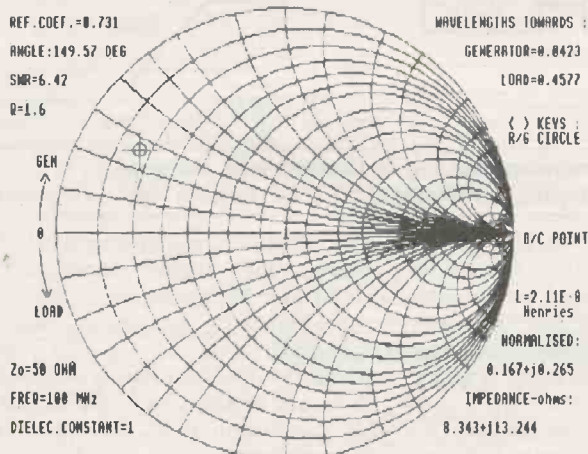

Z-MATCH – Takes the drudgery out of R.F. matching problems. Includes many more features than the standard Smith Chart. Provides solutions to problems such as TRANSMISSION LINE MATCHING for AERIALS and RF AMPLIFIERS with TRANSMISSION LINE TRANSFORMER and STUB MATCHING methods using COAXIAL LINES MICROSTRIP, STRIPLINE and WAVEGUIDES. The program takes account of TRANSMISSION LINE LOSS, DIELECTRIC CONSTANT, VELOCITY FACTOR and FREQUENCY. Z-MATCH is supplied with a COMPREHENSIVE USER MANUAL which contains a range of WORKED EXAMPLES

£130 ex VAT for PC/XT/AT etc.
£65.00 ex VAT for BBC B, B+ and Master

All major credit cards accepted
WRITE OR PHONE FOR FULL DETAILS:- REF PE

Number One Systems Ltd



CIRCUIT ANALYSIS BY COMPUTER – ANALYSER II

For IBM, PC/XT/AT and clones inc. Amstrad 1512, 1640, R.M. NIMBUS, and BBC B, B+, and Master.

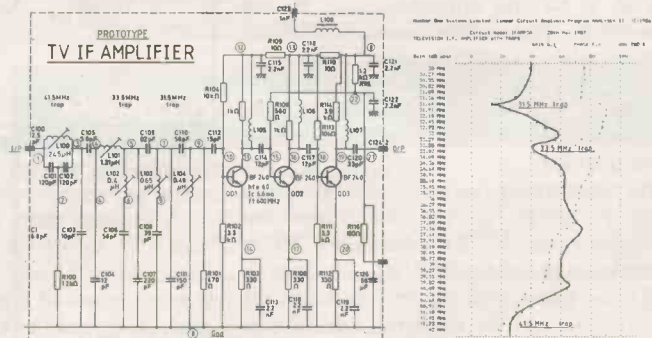

"ANALYSER II" – Analyses complex circuits for GAIN, PHASE, INPUT IMPEDANCE, OUTPUT IMPEDANCE and GROUP DELAY over a very wide frequency range. Ideal for the analysis of ACTIVE and PASSIVE FILTER CIRCUITS, AUDIO AMPLIFIERS, LOUDSPEAKER CROSS-OVER NETWORKS, WIDE-BAND AMPLIFIERS, TUNED R.F. AMPLIFIERS, AERIAL MATCHING NETWORKS, TV I.F. and CHROMA FILTER CIRCUITS, LINEAR INTEGRATED CIRCUITS etc. STABILITY CRITERIA AND OSCILLATOR CIRCUITS can be evaluated by "breaking the loop". Can save days breadboarding and thousands of pounds worth of equipment.

£195 ex VAT for PC/XT/AT etc.
£130 for BBC, B, B+ and Master

Harding Way, St Ives, Huntingdon Cambs, PE17 4WR
Tel: St Ives (0480) 61778 (4 lines)
We provide full after-sales support with free telephone 'hotline help' service.
Software updates are free within 6 months of purchase date.



In part one, Oct 89, I described the delay circuit options and modulation control. On now to the signal routing options.

INPUT AND OUTPUT

Since, in nature, echo and reverb signals are not necessarily direction conscious, especially in enclosed spaces, only one delay circuit is used, even though the unit is intended for stereo operation. There is, of course, no reason, other than financial, why separate delay stages should not be provided for each of the stereo channels. But, being cost conscious, I have used just the one delay path, routing both channels through it, and feeding the processed signal equally to both stereo output channels. Fig.9 shows the input and output signal circuit.

BAND PASS

Both input signals are also taken to the mixer-filter stage around IC1a. Here the combined signal level amplitude can be increased by VR1, from x1 one up to about x10. Some of the upper frequencies are removed by the action of C3 and C4, to reduce distortion through the delay stage. The band pass range for IC1a is about 100Hz to 5kHz.

Bass frequencies are those most prone to cause feedback howl in reverb modes and so I've included a bass-cut control, VR2. The cut can be set from nil up to around 1kHz. From the junction of C6 and R7, the composite signal is taken into C22 of the delay stage.

Following the delay stage, the signal is brought into IC1b. Here, the steps induced by the clocked sampling referred to earlier are partially filtered out. C8 and C9 set the

upper frequency filtering limit. The second filter around IC2 further smooths out the sampling steps, with C7 and C12 setting the frequency cut off. The upper limit is set at around 3.5kHz which allows adequate filtering out of clocking frequencies as low as 10kHz. Since the dominant frequencies in music lie at less than about 3.5kHz, it is basically the upper harmonics which are lost in the filtering, not the main signal content.

SPLIT AND MIX

The delayed and filtered signal is taken via the level control VR4 and split equally between IC1c and IC1d, where it is mixed with the original stereo signals. The processed signal can also be fed back into the delay chain at a level set by VR3.

Don't forget that when using more than one output from the MN3011, the signal

MONO-STEREO ECHO STATION

The stereo signal is input to the identical mixer stages IC1c and IC1d. The two channels retain their separate identities and amplitudes at the output of these ics, although there is an inversion of phase. The direct through frequency range is around 20Hz to better than 30kHz.

Part two - in which John Becker finds a constructive route through the operational delays.

levels will be added together, which could result in distortion if the levels are too high.

For effects where the processed signal is required on its own without being mixed with the original, the output may be taken directly from the wiper of VR4 to a separate output socket. (I have not included

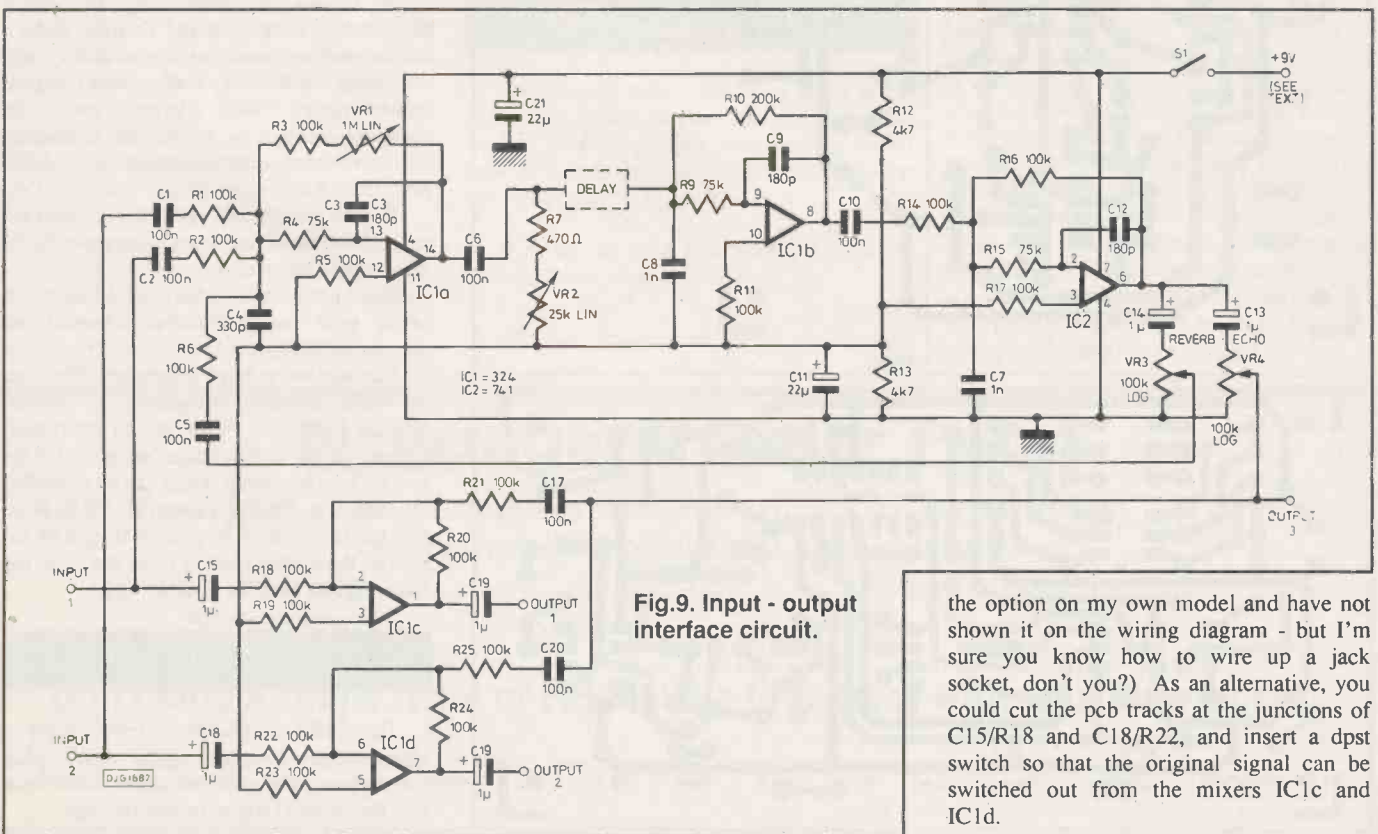

Fig.9. Input - output interface circuit.

the option on my own model and have not shown it on the wiring diagram - but I'm sure you know how to wire up a jack socket, don't you?) As an alternative, you could cut the pcb tracks at the junctions of C15/R18 and C18/R22, and insert a dpst switch so that the original signal can be switched out from the mixers IC1c and IC1d.

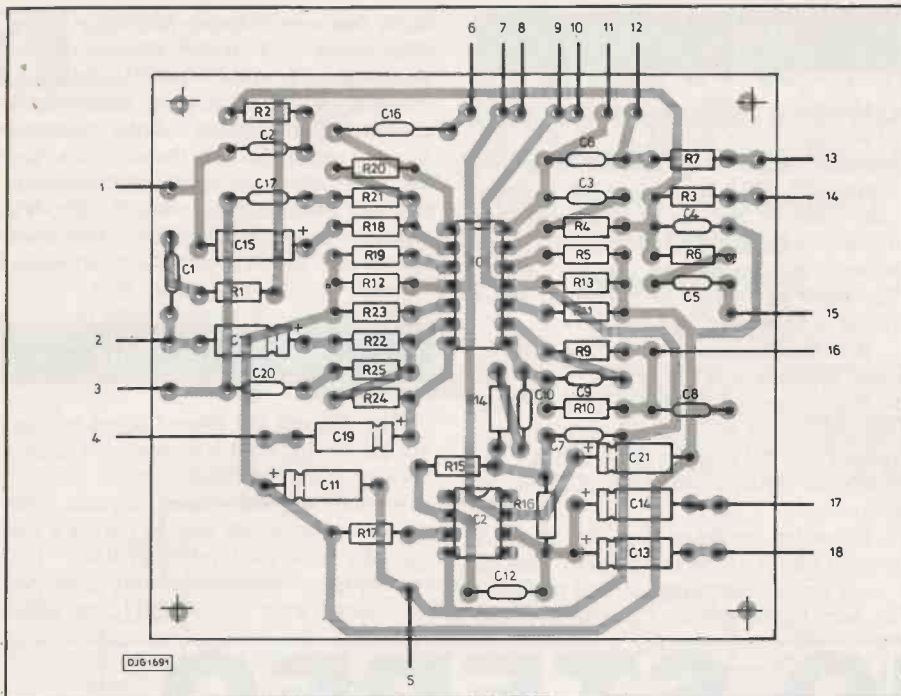

Fig. 10. Component layout for the interface pcb.

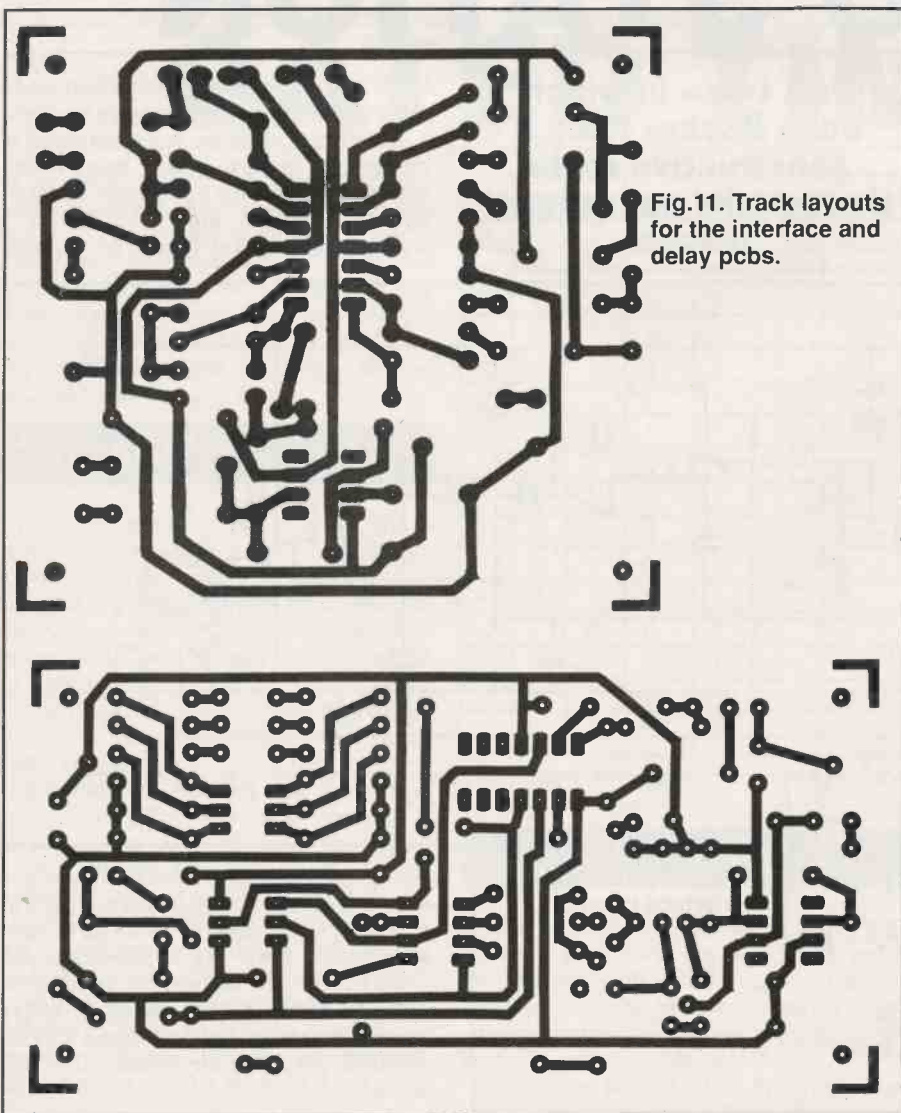

Fig. 11. Track layouts for the interface and delay pcbs.

SUPPLY VOLTAGES

The circuit has been designed to work with a single 9V battery as the power supply, though voltages up to around 15V dc are acceptable. At 9V the current consumption is around 11mA.

The maximum signal input strength to the delay chips is 1V rms for the MN3011, and 1.8V rms for the MN3004. Input levels above these figures will cause distortion, but will not damage the chips, providing the levels don't exceed the psu voltage.

The unit is designed for use with preamplified signals, and immediately prior to a power amplifier.

RATES AND MEASURES

Now for a list of the various clock rates and delay times to be expected. Individual units may vary slightly in their measurements due to normal component tolerance factors, but not too significantly.

Signal delays with the clock range controlled by VR9 set for 10kHz to 100kHz are :

MN3004	2.56ms to 25.6ms
MN3011 output 1	1.98ms to 19.8ms
MN3011 output 2	3.31ms to 33.1ms
MN3011 output 3	5.97ms to 59.7ms
MN3011 output 4	8.63ms to 86.3ms
MN3011 output 5	13.95ms to 139.5ms
MN3011 output 6	16.64ms to 166.4ms

Delay times may be extended beyond these figures by decreasing the clock frequency below 10kHz, though with a consequent reduction in signal quality and increased possibility of clock signal breakthrough. The latter may be compensated for by equivalent increasing of relevant capacitor values in filters IC1b and IC2.

Reverb lengths are controllable from nil to infinite (total feedback) irrespective of delay clock frequency.

Modulation rate : 8Hz to 13 secs. A faster rate range can be achieved by decreasing C27.

Modulation control example : VR9 set for basic clocking frequency of 16kHz, VR7 set midway, VR8 set to maximum output - clock sweep range becomes 10kHz to 23kHz. The sweep range can be extended by reducing the resistance of VR7. Note that the basic clock frequency should be set so that the sweep control does not drop the clocking rate into the audible range.

SETTING UP

Turn VR4 to minimum level, apply a signal to either or both of the inputs, plug the outputs into your amplifier and check that the original signal passes through.

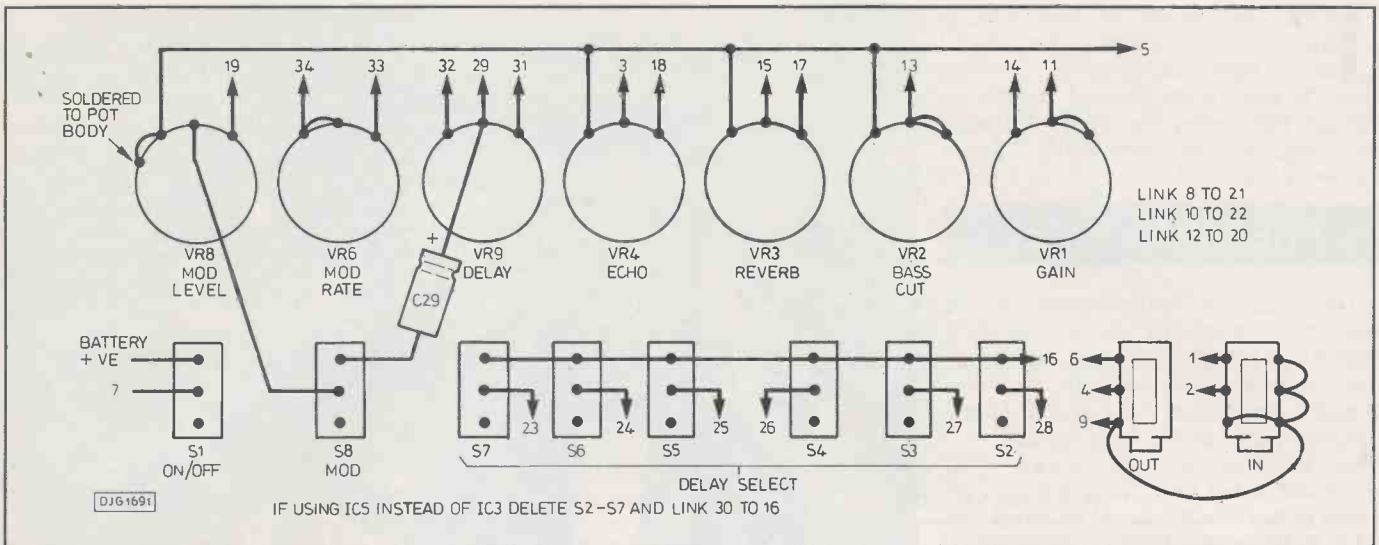

Fig.12. Control wiring diagram.

Set VR1 and VR3 to minimum, switch off S8 and turn up VR4 until a noticeably different signal quality is experienced. It is best if the signal has a significant beat to it so that echo repeats will be clearly heard. Play around with the delay switching options and the setting of the delay rate pot VR9, determining that the delay stage is functioning. Then check that feedback occurs when the reverb control VR3 is used. Now switch on S8 and test out the

modulation rate and control functions of VR6 and VR8.

Any malfunction is likely to be due to incorrect assembly or wiring, in which case thoroughly recheck your work.

Finally, set the preset pots for optimum conditions. If you have a scope, the setting of VR5 should be made to give symmetry to the delayed signal at VR4. For this, the signal strength should be close to maximum. Without a scope, adjust VR5

until minimum distortion is heard with strong signals. If you can hear no difference, set it about midway.

Adjust VR7 for the smoothest modulation when VR8 is at maximum level. VR10 should be adjusted until the clocking oscillator is not heard when VR9 is at minimum level (lowest clock speed).

So, there you are, a simple multipurpose delay unit using bbd chips other than the sadly missed TDA1022 and TDA1097. **PE**



★ LEARN BY BUILDING ★ ENJOY BY USING ★

PROJECT KITS

★ BE CREATIVE ★ GET KITTED! ★

HAPPY 25TH BIRTHDAY TO PRACTICAL ELECTRONICS! PHONOSONICS TOO ARE VETERANS - WE'VE SUPPORTED PE FOR 17 YEARS!



PE ECHO STATION
DETAILS IN CATALOGUE

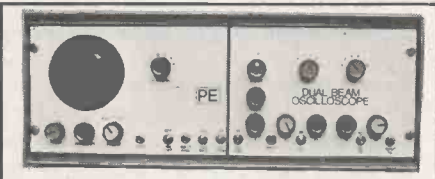

PE DUAL BEAM OSCILLOSCOPE
Details in catalogue.

MORE KITS IN CATALOGUE
SEND MEDIUM S.A.E. FOR CATALOGUE AND WITH ALL ENQUIRIES
(OVERSEAS SEND £1.00 TO COVER POSTAGE)

BURGLAR ALARM CONTROLLERS

MULTIZONE CONTROL SET280 £23.90
Two entry-zones, anti-tamper loop, personal attack, entry-exit timing, timed duration, automatic resetting, latching LED monitors.

SINGLE ZONE CONTROL SET279 £10.50
With timed duration control and latching LED monitor. Both units can be used with any standard detection devices, such as contact or magnetic switches, pressure pads, tremblers, ultrasonics, infrared etc., and will activate standard bells, strobes or sirens.

COMPUTER KITS

The software listings published with the computer kit projects are for use with C64, PET and BBC computers.

CHIP TESTER SET258F £41.50
Computer controlled logic and chip analyser.

EPROM PROGRAMMER SET277 £26.20
Computer controlled unit for 4K Eproms.

MICRO-CHAT SET276 £69.50
Computer controlled speech synthesiser.

MICRO-SCOPE SET247 £49.50
Turns a computer into an oscilloscope.

MICRO-TUNER SET257 £57.40
Computer controlled, tuning aid and freq counter.

MORSE DECODER SET269 £26.70
Computer controlled morse code-decoder.



PE FREQUENCY COUNTER AND GENERATOR
DETAILS IN CATALOGUE

VARIOUS

VOICE SCRAMBLER SET287 £49.50
32 switchable channels to keep your communications confidential.

STORMS! £35.50 each unit
Raw nature under panel control! Wind & Rain SET250W. Thunder & Lightning SET250T.

DISCO-LIGHTS SET245F £69.50
3 chan sound to light, chasers, auto level.

EVENT COUNTER SET278 £36.60
4-digit display counting for any logic source.

ENVIRONMENT

ELECTRONIC BAROMETER SET285 £41.20
Computer controlled unit for monitoring atmospheric pressure.

GEIGER COUNTER SET264 £65.50
A nuclear radiation detector for environmental and geological monitoring. With built in speaker, meter and digital output. This project was demonstrated on BBC TV.

ORDERING

Add 15% VAT. Add P&P - Sets over £50 add £3.00. Others add £2.00. Overseas P&P in catalogue. Text photocopies - Oscilloscope £3.00, Geiger £3.00, Weather £2.00, others £1.00, plus 50p post or large SAE. Insurance 50p per £50. MAIL ORDER, CWO, CHQ, PO, ACCESS VISA. Telephone orders: Mon-Fri, 9am - 6pm. 0689 37821. (Usually answering machine).

MORE KITS IN CATALOGUE

PHONOSONICS, DEPT PE99, 8 FINUCANE DRIVE, ORPINGTON, KENT, BR5 4ED.

MAIL ORDER

In the words of the old song, *What a night it was, it really was such a night!* Such a night was September 27th 1989 when PE and friends gathered together to celebrate PE's twenty-five years of history. The venue was the Kew Bridge Steam Museum, London.

PREPARATORIES

The preparations for the celebrations had been on our minds for months, the party dominating the thoughts and actions of everyone in the office, especially Mary-Ann Hubers, Louise Hewett and Publisher Angelo Zgorelec. Questions like: Who should come? What shall we eat and drink? What decorations do we have? What gift shall we present to Sir Clive Sinclair as his award? All had to be thoroughly discussed and solutions concluded.

The Birthday issue itself, its contents and appearance, had occupied me far longer than any other issue, until a week before the party when the pages at last were sent to the printers. Somewhat anticlimactically, I now had to prepare the December issue, trying to



Some of PE's well-wishers enjoy nostalgic reunions and spirited chats at the Kew Bridge Steam Museum. The rest of the crowd are off-stage, touring the ancient pumping machinery.

CELEBRATING A PARTY TO REMEMBER!

ignore the November one which was out of my hands until we received the printed copies. These arrived at the office with only hours to spare before the party, at which we were to present them to everyone there!

The party preparations were going on right up to the last minute before our guests arrived. Balloons were being blown, banners going up, food laid out, microphones placed,

The glittering cut-glass PE Technology Award



Ignoring his Bacchanalian hangover, John Becker recalls the festivities of PE's 25th Anniversary Party!

and the steam engines brought up to steam - it wasn't just a party to celebrate the hi-tech, but a grand tour of Ancient Technology as well.

GREETING GUESTS

Angelo and myself greeted our guests as they arrived at the main entrance, inviting them to sign our commemorative visitors book, and directing them through the maze of corridors between the historical machinery, and along to the main hall. It was a real pleasure to greet so many people whom I had come to know over the years, and to welcome those I only knew by reputation but had never met. When Sir Clive arrived, he too was obviously pleased to see people he had known since his early days in electronics.

In fact, it was obvious that many people knew each other, and the hubbub of

reminiscing chatter and the gentle murmur of working steam engines was an exhilarating and heart-warming sound.

HEART-FELT WELCOMES

We'd agreed, Angelo and I, that we would keep speeches to a mere minimum - we wanted people to enjoy themselves in true party fashion, not to have their ears bent for too long by formal speeches. So, it was almost with reluctance that I intruded upon the conversations by asking for people's attention to a few formalities!

Angelo then warmly welcomed everyone, and said a special word of thanks to Sir Clive for joining us all, and how pleased we were that the readers had shown such discernment in nominating him for the PE Technology Award.

On accepting the mic back from Angelo, I offered my own greetings to all present, most of whom were part of PE's story, going right back to the early days. There were PE staff members, advertisers, authors, printers, distributors, manufacturers, retailers and readers. It was certainly a proud day for us who now work on PE to have them all join in our celebrations. We were especially pleased to have with us PE's founding editor, Fred Bennett, and his successor Mike Kenward. Sadly, one expected special guest, Dr Patrick Moore, was unable to join us as he'd been delayed in South Africa.



Sir Clive Sinclair, awarded in recognition of his technology achievements over the last twenty-five years.

AWARDING SIR CLIVE

We were proud too that our readers had overwhelmingly voted Sir Clive as the personality who has done most to promote technology over the last twenty-five years. Loud applause greeted him as I invited him to come forward to receive the award, an absolutely superb glittering glass pyramid, standing a good ten inches high. It was inscribed with the words, "The Practical

Devotees to technology: PE founding editor Fred Bennett, his successor Mike Kenward, Sir Clive Sinclair, PE publisher Angelo Zgorelec, current PE editor John Becker.



Electronics 25th Anniversary Award 1989 Presented to Sir Clive Sinclair in Recognition of his Achievements in Technology."

Beaming broadly, Angelo presented the award to Sir Clive, who thanked us all smilingly, accompanied by the brilliance of numerous camera flash guns, followed by more loud applause.

TECHN-ODE-OLGY

Then I broke my oath of brevity! I couldn't let an occasion like a PE Silver Anniversary Party pass without a commemorative Odd-Ode, which I'd just happened to scribble down on the back of an old pcb while waiting in a traffic jam on the way to the party!

In days of old
Young Fred, so bold,
This PE mag invented -

He'd seen the signs
That hi-tech times
Were for the fans intended,
And his battle cry
Was heard on high:
"This market's undefended!"

So from Sixty-Four
With PE's galore
The hobbyists he contented,
Bringing folks to grips
With boards and chips,
And features techno-splendid!

Then Mike from Fred
Became the Ed,
And though now relocated,
Through the Micro years
He brought great cheers,
And PE much commended!

But recession's hold
Brought plights untold
And fortunes were upended,
Till from the wings,
"Allelujah!" rings -
Guardian Angelo has descended!

Now we're legend bound
And techno-crowned
And our pages are well tended,
Thus to such acclaim
We admit our fame,
With glowing pride subtended.

So raise your beers
To hi-tech years
And make us all beholden
To turn PE
From Silvered glee
Into the bloomin' Golden!

GRAND TOUR

After which, a libation to PE and Technology; then on to the Grand Tour!

You probably don't know, but Derek Gooding, as well as being our illustrious technical illustrator, also helps to run the Steam Museum. It was only natural then, that he should guide us round the highly impressive pumping machinery, gleaming with the typical well-oiled brightness of well-cared-for precision engineering. Derek's knowledgeable and witty commentary had us enthralled while the massive machinery sleekly drove the beams and pistons through their motions.



PE's technical illustrator Derek Gooding describes the fascination of the Steam Museum machinery, flanked by Helen and Andrew Armstrong, PE sub editor and author respectively.

If you're ever near the Kew Bridge Steam Museum, do call in for a look round, it's really interesting. You'll find it in Green Dragon Lane, Brentford, Middx, phone 01-568 4757. It's open daily, and the engines are 'In-steam' at weekends.

EAT, DRINK AND BE MERRY!

Many of us then stayed on for more chats, while attempting to consume the remaining consumables, animal, vegetable, but not mineral - champagne and other similar beverages are far more appropriate than mineral waters!

Then off home, exhilarated!

PE

MAGENTA ELECTRONICS Ltd

PROJECT KITS

Magenta supply Full Kits: Including PCB's (or Stripboard), Hardware, Components, and Cases (unless stated). Please state Kit Reference Number, Kit Title and Price, when ordering.
REPRINTS: If you do not have the issue of P.E. which includes the project, you will need to order the instruction reprint as an extra: 80p each. Reprints are also available separately - Send £1 in stamps. Magazine dates refer to Everyday Electronics.

REF NO.	KIT-TITLE	PRICE	REF NO.	KIT-TITLE	PRICE
816	STEPPING MOTOR DRIVER As featured in Aug P.E. Superb controller with half-step ability Offer Price with MD35 Motor	£7.94 kit only £14.99	581	VIDEO GUARD Feb. 87	£8.94
812	ULTRASONIC PET SCARER May 89	£13.80	584	SPECTRUM SPEECH SYNTH. (no case) Feb. 87	£22.28
807	MINI PSU Feb 89	£22.71	578	SPECTRUM I/O PORT less case Feb. 87	£10.05
806	CONTINUITY TESTER	£10.28	569	CAR ALARM Dec. 86	£13.28
803	REACTION TIMER Dec. 88	£31.93	563	200MHz DIG. FREQUENCY METER Nov. 86	£67.98
801	DOWNBEAT METRONOME Dec. 88	£18.71	561	LIGHT RIDER LAPEL BADGE Oct. 86	£10.86
800	SPECTRUM EPROM PROGRAMMER Dec. 88	£28.72	560	LIGHT RIDER DISCO VERSION	£20.89
795	SEASHELL SYNTHESIZER Nov. 88	£26.61	559	LIGHT RIDER 16 LED VERSION	£14.52
795	I.R. OBJECT COUNTER Nov. 88	£31.56	556	INFRARED BEAM ALARM Sept. 86	£30.19
790	EPROM ERASER Oct. 88	£26.57	544	TILT ALARM July 86	£8.33
786	UNIVERSAL NICAD CHARGER July 88	£7.44	542	PERSONAL RADIO June 86	£12.28
780	CABLE & PIPE LOCATOR April 88	£16.35	528	PA AMPLIFIER May 86	£28.70
775	ENVELOPE SHAPER Mar 88	£15.96	523	STEREO REVERB Apr. 86	£28.16
769	VARIABLE 25V-2A BENCH POWER SUPPLY Feb 88	£52.96	513	BBC MIDI INTERFACE Mar. 86	£29.76
763	AUDIO SIGNAL GENERATOR Dec. 87	£14.53	512	MAINS TESTER & FUSE FINDER Mar. 86	£9.39
739	ACCENTED BEAT METRONOME Nov 87	£22.31	497	MUSICAL DOORBELL Jan. 86	£19.95
740	ACOUSTIC PROBE Nov 87 (less bolt & probe)	£18.46	493	DIGITAL CAPACITANCE METER Dec. 85	£44.25
744	VIDEO CONTROLLER Oct. 87	£31.03	481	SOLDERING IRON CONTROLLER Oct. 85	£5.83
745	TRANSISTEST Oct 87	£10.33	464	STEPPER MOTOR INTERFACE FOR THE BBC COMPUTER less case Aug. 85	£8.95 £16.50
734	AUTOMATIC PORCH LIGHT Oct. 87	£18.29	461	OPTIONAL POWER SUPPLY PARTS	£5.47
736	STATIC MONITOR Oct. 87	£9.22	455	CONTINUITY TESTER July 85	£5.60
723	ELECTRONIC MULTIMETER Sept 87	£50.01	455	ELECTRONIC DOORBELL June 85	£6.60
728	PERSONAL STEREO AMP Sept 87	£15.24	453	GRAPHIC EQUALISER June 85	£28.69
730	BURST-FIRE MAINS CONTROLLER Sept 87	£14.45	444	INSULATOR TESTER Apr. 85	£20.85
724	SUPER SOUND ADAPTOR Aug 87	£40.89	430	SPECTRUM AMPLIFIER Jan 85	£7.36
718	3 BAND 1.6-300MHz RADIO Aug. 87	£28.25	392	BBC MICRO AUDIO STORAGE SCOPE INTERFACE Nov 84	£38.61
719	BUCANEER I.B. METAL DETECTOR inc. coils and case, less handle and hardware July 87	£28.17	387	MAINS CABLE DETECTOR Oct. 84	£5.89
720	DIGITAL COUNTER/FREQ METER (10MHz) inc. case July 87	£71.43	386	DRILL SPEED CONTROLLER Oct 84	£9.24
722	FERMOSTAT July 87	£12.93	362	VARICAP AM RADIO May 84	£14.00
711	VISUAL GUITAR TUNER Jun 87	£24.48	337	BIOLOGICAL AMPLIFIER Jan 84	£25.71
715	MINI DISCO LIGHT Jun 87	£13.41	263	BUZZ OFF Mar. 83	£5.95
707	ACTIVE I/R BURGLAR ALARM Mar. 87	£37.97	242	2-WAY INTERCOM no case July 82	£6.06
			240	EGG TIMER June 82	£7.31
			205	SUSTAIN UNIT Oct 81	£18.78
			108	IN SITU TRANSISTOR TESTER June 78	£10.03
			106	WEIRD SOUND EFFECTS GEN. Mar. 78	£8.33
			101	ELECTRONIC DICE Mar. 77	£6.67

TOP KITS F

MOSFET VARIABLE BENCH 25V 2.5A POWER SUPPLY



A superb design giving 0-25V and 0-2.5A. Twin panel meters indicate Voltage and Current. Voltage is variable from zero to 25V. Current-Limit control allows Constant Current charging of NICAD batteries, and protects circuits from overload. A Toroidal transformer MOSFET power output device, and Quad op-amp IC design give excellent performance.

OUR KIT REF. 769 £52.96

COMPONENTS, KITS, BOOKS, TOOLS,
MOTORS, GEARS, PULLEYS, OPTICAL
FIBRES, ROBOTICS, AND MUCH MUCH
MORE-IN OUR
CATALOGUE £1.00

EE TREASURE HUNTER

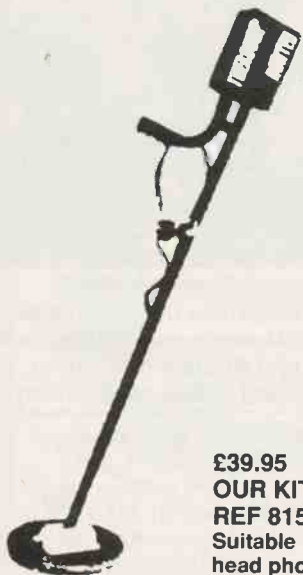

£39.95
OUR KIT
REF 815
Suitable
head phone
£1.99

P.I. METAL DETECTOR

A sensitive pulse induction Metal Detector. Picks up coins and rings etc. up to 20cms deep. Low "ground effect". Can be used with search-head underwater. Easy to use and build, kit includes search-head, handle, case, P.C.B. and all parts as shown.

DIGITAL FREQUENCY 200 MHz METER

KIT REF 563 £67.98

An 8 digit meter reading from A.F. up to 200 MHz in two ranges. Large 0.5" Red LED display ideal for AF and RF measurements. Amateur and C.B. frequencies.

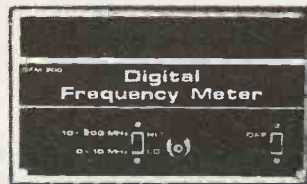

VISUAL GUITAR TUNER



Crystal controlled, with a super rotating LED display. Indicates high, low, and exact degree of mistuning. Use with pick-up or mic. Also has audible output.

KIT REF E711 £24.98

3 BAND SHORTWAVE RADIO

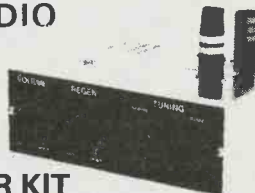

OUR KIT
REF 718 £28.25

Covers 1.6-30 MHz in 3 bands using modern miniature coils. Audio output is via a built-in loudspeaker. Advanced design gives excellent stability, sensitivity and selectivity. Simple to build.

MOTOR- GEARBOX ASSEMBLIES

Miniature gearboxes complete with quality electric motor. Variable ratios by fitting 1 to 6 gears. 1.5-4.5v, 3-2200 rpm. Long 3mm shaft. Ideal for robots and buggies.

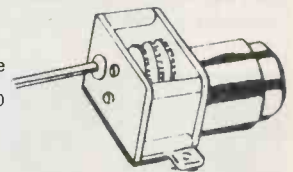

SMALL (MGS) £3.99 LARGE (MGL) £4.55

ADVENTURES WITH ELECTRONICS

BOOK £4.75 PACK £22.35
An easy to follow book suitable for all ages. No soldering, uses an S DEC breadboard. Lots of clear diagrams and instructions to build 16 projects. Component pack includes S DEC and all components for the projects.

LEGO Technic Sets
TEACHERS WE ARE STOCKISTS OF THE WHOLE RANGE. CONTACT US FOR BROCHURES. VERY COMPETITIVE PRICES AND QUICK DELIVERIES

STEPPING MOTORS 12 VOLT

48 STEPS 1035 £16.50
200 STEPS M0200 £16.80

OPTICAL
FIBRES
TRIAL
PACK OF
10
METRES.
Nine
assorted
types
& data.

£1.99

Fax: 0283 46932
Phone: 0283 65435



ROM MAGENTA

A SELECTION OF OUR BEST PROJECT KITS

As usual these kits come complete with printed circuit boards, cases, all components, nuts, screws, wire etc. All have been tested by our engineers (many of them are our own designs) to ensure that you get excellent results.

INSULATION TESTER

An electronic High Voltage tester for mains appliances and wiring. An inverter circuit produces 500 volts from a PP3 battery and applies it to the circuit under test. Reads insulation up to 100 Megohms. Completely safe in use.



OUR KIT REF 444 £20.85

MAGENTA ELECTRONICS LTD
 PE16 HUNTER STREET,
 BURTON-ON-TRENT,
 STAFFS. DE14 2ST.
 0283 65435, Mon-Fri 9-5 Sat 9-2
 Access/Barclaycard (Visa) by
 phone or post.
 24 hr Answerphone for credit
 card orders.
 Our prices include VAT

ADD £1 P&P TO ALL ORDERS.
PRICES INCLUDE VAT.
SAE ALL ENQUIRIES.
OFFICIAL ORDERS WELCOME
OVERSEAS: Payment must be
sterling.
IRISH REPUBLIC and BFPO. UK
PRICES.
FAX: 0283 46932

DIGITAL CAPACITANCE METER

Simple and accurate (1%) measurements of capacitors from a few pF up to 1,000 uF. Clear 5 digit LED display indicates exact value. Three ranges pF, nF, and uF. Just connect the capacitor, press the button and read the value.



£44.25
OUR KIT
REF 493

MAGENTA

68000

LOWCOST

CROSS-ASSEMBLER
FOR BBC. ALSO
AVAILABLE
(£60.00
DISK)

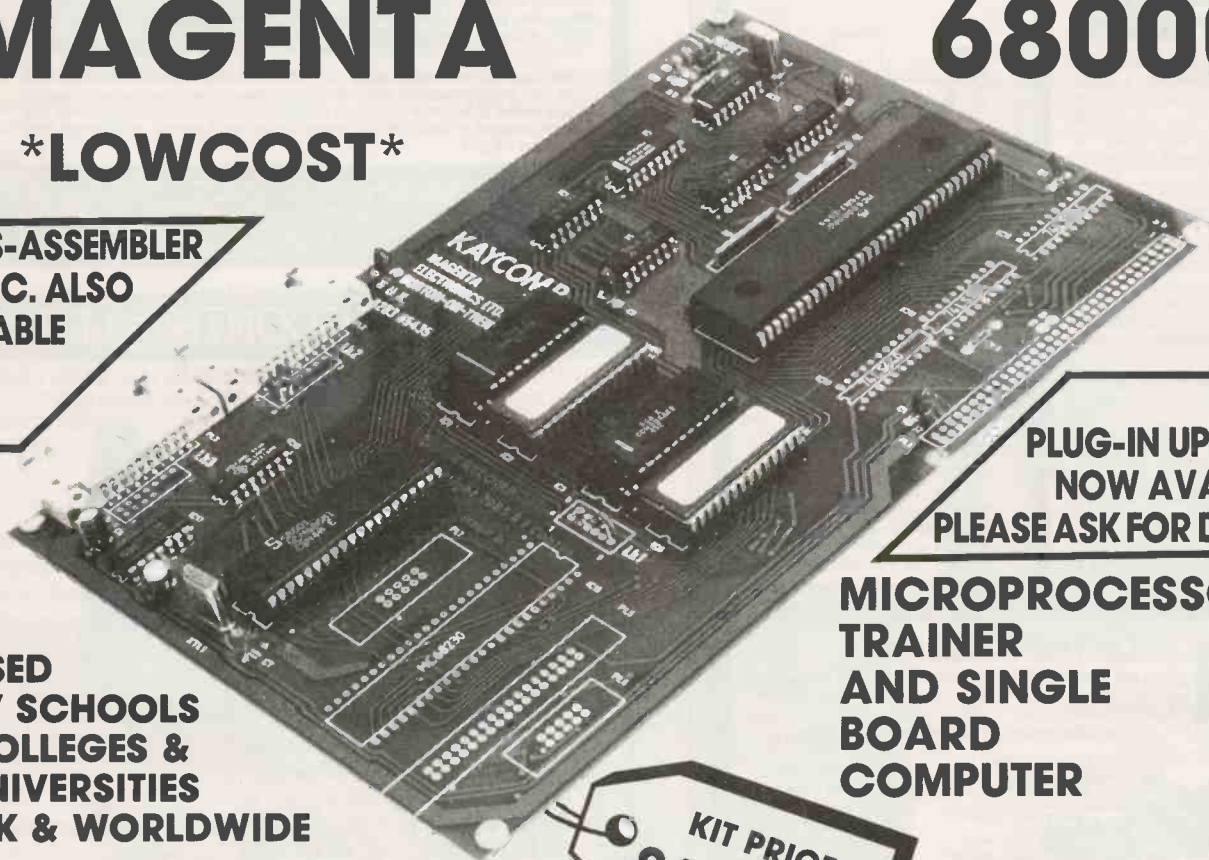

68020
PLUG-IN UPGRADE
NOW AVAILABLE
PLEASE ASK FOR DETAILS

USED
BY SCHOOLS
COLLEGES &
UNIVERSITIES
U.K & WORLDWIDE

MICROPROCESSOR
TRAINER
AND SINGLE
BOARD
COMPUTER

***PERFECT FOR ROBOTICS**
APPLICATIONS REQUIRING
POWER AND SPEED*

KIT PRICE
£110 INC VAT

OTHER OPTIONS, DATA PACKS,
AND LITERATURE AVAILABLE
- SEND FOR DETAILS.

- Full 8MHz 68000 Processor with 16 bit data bus.
- Top-class monitor program included on two Eproms.
- Communicates via RS232 Interface to terminal, BBC computer, P.C. computer etc.
- Use as a Trainer, or as a stand-alone computer system.
- Fast, powerful processing - Ideal for real time control systems.

- Dual U.A.R.T. allows simultaneous connection of printer and terminal.
- Add-on options include: G64 Bus, 68230 P.I.T. 8k and 32K Ram upgrades, and line by line assembler.
- Available from stock now - with support literature and full technical back up.

STANDARD SYSTEM IN KIT FORM (Ref 600)	£110.00	68230 P.I.T. ADD ON OPTION (Ref 603)	£11.97
STANDARD SYSTEM BUILT & TESTED	£190.00	G64 BUS ADD-ON (Ref 604)	£ 5.49
LINE BY LINE ASSEMBLER PROGRAM (IN EPROM)	£ 27.00	8K x 16 RAM UPGRADE (Ref 605)	£24.00
POWER SUPPLY (Ref 609)	£ 13.99	32K 16 RAM UPGRADE Ref 606	£52.00

VOICE RECORD/PLAYBACK KIT

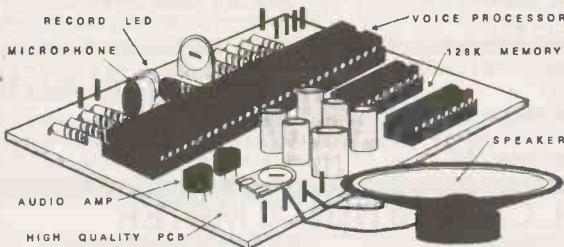

This simple to construct and even simpler to operate kit will record and playback short messages or tunes. It has many uses - seatbelt or lights reminder in the car, welcome messages to visitors at home or at work, warning messages in factories and public places, in fact anywhere where a spoken message is announced and which needs to be changed from time to time. Also suitable for toys - why not convert your daughter's £8 doll to an £80 talking doll!!

Size 78x60x15mm
 Message time 1 - 5 secs normal speed, 2 - 10 secs slow speed

XK129 £22.50

DISCO LIGHTING KITS



DL8000K 8-way sequencer kit with built-in opto-isolated sound to light input. Only requires a box and control knob to complete. **£34.60**

DL1000K 4-way chaser features bi-directional sequence and dimming 1kW per channel. **£21.00**

DLZ1000K Uni-directional version of the above. Zero switching to reduce interference. **£11.80**

DLA/1 (for DL & DLZ1000K) Optional opto input allowing audio 'beat'/light response. **80p**

DL3000K 3-channel sound to light kit, zero voltage switching, automatic level control and built-in mic. 1kW per channel. **£17.00**

POWER STROBE KIT

Produces an intense light pulse at a variable frequency of 1 to 15Hz. Includes high quality PCB, components, connectors, 5Ws strobe tube and assembly instructions. Supply: 240V ac. Size: 80 x 50 x 45. **£15.00**



VERSATILE REMOTE CONTROL KIT



Includes all components (+transformer) for a sensitive IR receiver with 16 logic outputs (0-15V) which with suitable interface circuitry (relays, triacs, etc - details supplied) can switch up to 16 items of equipment on or off remotely. Outputs may be latched to the last received code or momentary (on during transmission) by specifying the decoder IC and a 15V stabilised supply is available to power external circuits. Supply: 240V AC or 15-24V DC at 10mA. Size (exc transformer) 9x4x2 cms. Companion transmitter is the MK18 which operates from a 9V PP3 battery and gives a range of up to 60ft. Two keyboards are available - MK9 (4-way) and MK10 (16-way).
 MK12 IR Receiver **£17.00**
 (inc transformer)
 MK18 Transmitter **£7.80**
 MK9 4-way Keyboard **£2.40**
 MK10 16-way Keyboard **£7.00**
 601133 Box for Transmitter **£2.60**

ELECTRONIC LOCK KIT

Don't lock yourself out! This high security lock kit will secure doors to sheds, garages or your front door and the built-in alarm will deter would be prowlers. Scores of uses including area access preventing unauthorised use of machinery or even disabling your car. One correct 4 digit code (out of 5000) will open the lock. Incorrect entries sound the alarm and disable the keyboard for up to 3 mins. Kit includes 12 way keypad, and operates from 9 to 15V (50uA) supply. Will drive relay or 701 150 lock mechanism.

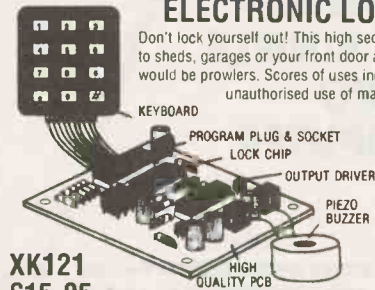

**XK121
 £15.95**

TH ELECTRONICS

13 BOSTON RD. LONDON W7 3SJ
 TEL: 01-567 8910.
 FAX: 01-566 1916



ORDERING INFORMATION:

All prices exclude VAT. Free P & P on orders over £50 (UK only), otherwise add £1 + VAT. Overseas P & P: Europe £3.50. Elsewhere £10. Send cheque/PO/Visa/Access No. with order. Giro No. 529314002
LOCAL AUTHORITY AND EXPORT ORDERS WELCOME
GOODS BY RETURN SUBJECT TO AVAILABILITY

SURVEILLANCE PROFESSIONAL QUALITY KITS

A range of high quality kits as supplied to leading UK security companies, all in-house designed and produced, not to be confused with cheap imports. All kits come fully documented with concise assembly and setting-up details, fibreglass PCB and all components. All transmitters are fully tuneable and can be monitored on a normal VHF radio or tuned higher for greater security. Build up service available if required.

- MTX Micro Miniature audio transmitter.**
 17mm x 17mm. 9V operation. 1000m range. **£12.95**
- VT500 Hi-power audio transmitter.**
 250mW output. 20mm x 40mm. 9-12V operation. 2-3000m range. **£15.95**
- VOX75 Voice activated transmitter.**
 Variable sensitivity. 30mm x 40mm. 9V operation. 1000m range. **£18.95**
- CTX900 Sub-carrier scrambled audio transmitter.** Cannot be monitored without decoder fitted to radio. 30mm x 40mm. 9V operation. 1000m range. **£21.95**
- DSX900 Sub-carrier decoder unit for monitoring CTX900.** Connects to radio earphone socket. Provides output for headphones. 35mm x 50mm. 9-12V operation. **£21.95**
- HVX400 Mains powered audio transmitter.**
 Connects directly to 240V AC supply. 30mm x 35mm. 500m range. **£18.95**
- XT89 Crystal controlled audio transmitter.**
 High performance. 100mW output. Supplied with xtal for 108MHz. Others available to 116MHz. 85mm x 28mm. 9V operation. 2-3000m range. **£36.95**
- TKX900 Tracker/Beeper transmitter.**
 Transmits continuous stream of audio pulses. Variable tone and rate. Powerful 200mW output. 63mm x 25mm. 9V operation. 2-3000m range. **£21.95**
- ATR2 Micro size telephone recording interface.** Connects between telephone line (anywhere) and cassette recorder. Tape switches automatically with use of phone. All conversations recorded. Powered from line. 10mm x 35mm. **£12.95**
- TLX700 Micro Miniature telephone transmitter.** Connects to line (anywhere) switches on and off with phone use. All conversations transmitted. 20mm x 20mm. Powered from line. 1000m range. **£12.95**
- XML900 RF bug detector.** Variable sensitivity. Triggers LED and beeper when in presence of RF field. Detects MTX 15-20 feet. 55mm x 55mm. 9V operation. **£26.95**
- XL7000 Professional bug detector/locator.** Variable sensitivity. Twin mode ten segment LED readout of signal strength with variable rate beeper. Second mode AUDIO CONFIRM distinguishes between localised bug transmission and normal legitimate signal such as pagers, cellular etc. 70mm x 100mm. 9V operation. **£54.95**

UK customers please send cheques, PO's or registered cash. Please add £1.50 per order for P&P. Goods despatched ASAP allowing for cheque clearance. Overseas customers send sterling bank draft or Eurocheque and add £5.00 per order for shipment. Credit card orders accepted on 0827 714476. Full catalogue available on receipt of 28p stamp. Trade enquiries welcome.



THE WORKSHOPS
 95 MAIN ROAD, BAXTERLEY
 Nr Atherstone. WARCS CV9 2LE



0827 714476

Z80A MICROCONTROLLER

A low cost single board micro-system providing all the requirements needed for many applications in industrial, experimental and educational fields.

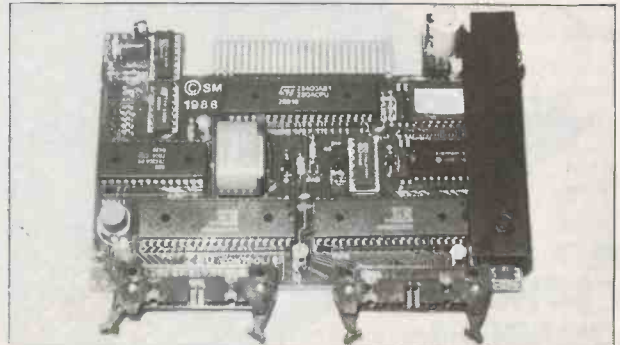

Just some of its extensive features include:

- ★ Z80A CPU operating at 4MHz
- ★ EPROM socket - jumper link selectable as 2, 4, 8, 16 or 32K accepts 2716/2732/2764/27128/27256 EPROMS
- ★ RAM socket - jumper link selectable as 2, 8 or 32K accepts 6116/6264/62256 CMOS static RAMS - battery back up included
- ★ INPUT/OUTPUT - 2 Z80 PIOs providing 32 programmable I/O lines
- ★ HARDWARE COUNTER/TIMER - a Z80 CTC providing four independent counter/timer circuits
- ★ Expansion boards available - DtoA, 8 channel AtoD, RS232 serial I/O etc
- ★ Full documentation and user notes

Z80 Single Board Controller fitted with 2Kx8 CMOS static RAM ONLY £94.95 + VAT - BUILT AND TESTED !!

Specialising in microprocessor data logging and control applications, we provide a complete service covering any or all of the stages from initial hardware and software design through manufacture to final installation.

Phone/send for full details - OEM, trade and overseas enquiries welcome

SM ENGINEERING
 Telephone 0323-766262

'St. Georges' Lion Hill Stone Cross
 Pevensey, East Sussex BN24 5ED



The true rms voltmeter of this design uses exactly the same electronic circuit as the ammeter already described in PE June 89. The only difference is that the heater coil on diode sensor D1, which is a low-resistance heater consisting of a few turns of thick Nichrome wire in the ammeter version, is now a high-resistance heater consisting of a large number of turns of fine, insulated Nichrome wire. There are also some physical differences which will be described later.

HEATER COIL

The wire used for the voltmeter heater coil is 47 or 48 swg enamelled Nichrome (available from Magenta Electronics) which is doubled back on itself and then twisted together before being wound onto the coil former. This reduces any inductive effects which would make the effective input resistance dependent on frequency, and thus affect the reading. Fig. 1 shows how to wind the twist into the wire.

Do not worry about handling such fine wire; Nichrome is much tougher than copper wire of the same diameter. It is however difficult to see the wire in poor light, so this job is best done in strong light. I did it out-of-doors on a sunny day and had no problem.

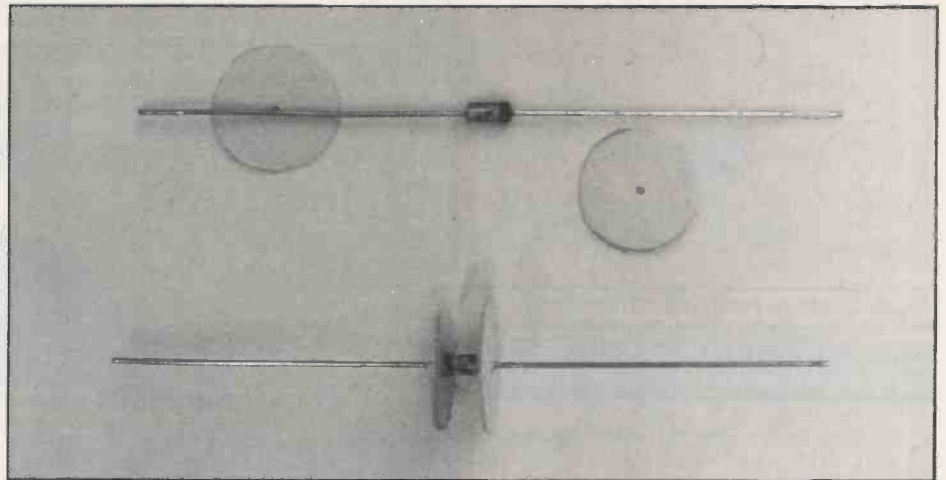

Fig 2. Diode and card cheeks before and after assembly.

with Araldite. Fig. 3 shows how. The cheeks are made oversize to begin with, and are cut down to size after coil-wind is complete. Make sure there is a generous fillet of Araldite as shown, since this ensures good electrical isolation between input and the instrument.

The best way to wind the coil is by hand - there are not so many turns that a mechanical method is needed. There is however a knack in starting the turns, because Nichrome wire is slightly springy. Use the cotton thread at the

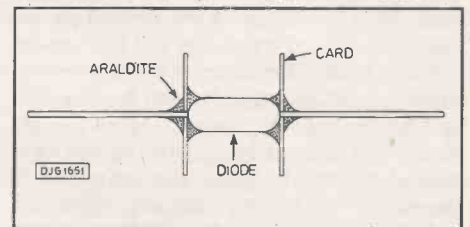

Fig 3. How the coil former should be glued for maximum insulation.

THERMAL-CONVERSION VOLTMETER

First, wind off a length of wire which gives a resistance of just over 5k. With 47 swg this length is about 10 metres and with 48 swg about 7 metres, but these figures can vary due to slight differences in the alloy and manufacturing tolerances when drawing the wire. Err on the generous side.

Now, find the mid-point and attach a piece of cotton thread. Combine the two loose ends and tie on a thin rubber band. Fix the rubber band to something solid at waist height (a door handle is very convenient!) and put the cotton thread in the chuck of a hand-drill. Do not try to use a power drill or the results will be spectacularly messy. Now, keeping some tension on the wire via the rubber band, turn the drill and twist the wire, stopping if necessary to even out the twists along the length. There is no well-defined number of twists to recommend - just keep going until it gets difficult to produce even twisting.

COIL FORMING

The coil former is made by taking diode D1 and cementing two thin card cheeks onto it

Fig 1. How to wind the twist into the wire.

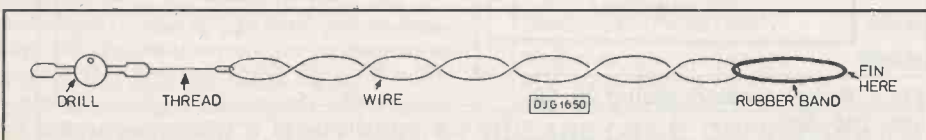

Rod Cooper follows his previous ammeter with another meter for use in power electronics.

mid-point to hold the wire in place while you wind on a few turns, but do not put any turns over the thread. After about ten turns, the wire will hold itself in place and you can slip the cotton thread off, and you can then continue winding. Without this technique, you will find it difficult to commence the turns.

After a number of turns, you can double-back on the winding to help minimise inductance, although this is not strictly necessary for general use on the types of applications outlined in the June issue. When winding is finished, test the resistance with an ohmmeter, and then wind off a few turns at a

time testing as you go until you have exactly 5k ohms. The heater coil can then be completed by winding on a few turns of fine cotton thread to hold the Nichrome wire in place and to provide some mechanical protection during assembly. Leave about 2 or 3 cm of wire as lead-outs.

HEAT SINKS

Unlike the ammeter, which used four copper heat-sinks, the voltmeter has only two heat-sinks. The amount of heat which would be conducted down fine Nichrome lead-out wires is negligible compared with the much thicker ammeter lead-out wires, so it is not worth providing a heat-sink. The heat exit path is confined to the diode leads, and the heat-sinks for these are exactly the same as those used in the ammeter, except that the spacing dimensions are different. The recommended distances are shown in Fig. 4.

Because there are only two heat-sinks, the heat exit path length must be shortened to keep the right balance between the thermal time-constant and sensitivity. If you reduce the distances shown in Fig. 4, the sensitivity goes down, but the time needed to take a reading also goes down, and vice versa. Like the ammeter, the practical result is a compromise, which can be altered at will to suit the constructor.

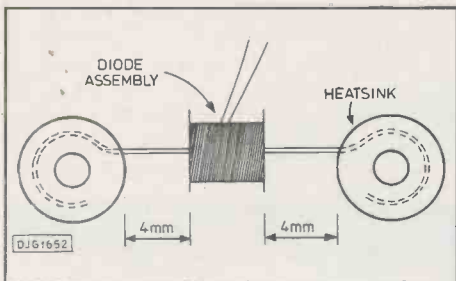

Fig 4. Diode to heatsink dimensions.

SENSOR ASSEMBLY

As with the ammeter, the diode and heater assembly is covered in a small piece of polystyrene top and bottom. I used 7mm polystyrene, with a piece of bright capacitor foil sandwiched between two layers for both top and bottom sections to reflect heat and thus prevent radiation losses. The pieces of polystyrene were simply pushed into place between the heat-sinks and held in place by friction. To enclose the heater coil completely, a little pressure was applied to squash the polystyrene down over the assembly. There is sufficient "give" in polystyrene to do this, but be careful.

Don't forget to pull out the two lead-out wires before finally encapsulating the diode/heater assembly. These two wires need to be anchored, otherwise they are likely to be damaged during assembly. The easiest way is to mount a piece of terminal strip as close as possible to the heat sinks. Although it is quicker to make flying leads out of these wires by simply soldering on extension wires, if you pull out one during assembly, you will have to start all over again. The photograph shows an alternative to tag-strip anchoring.

The compensating diode D2 can be clipped onto the heat-sink or glued on with Araldite. In the photograph, this has been removed for clarity.

CIRCUIT ASSEMBLY

Assembly of the rest of the circuit is straightforward and has been described in the June article. Calibration is similar and is done with a dvm and a variable voltage power supply. First, zero the meter with VR1, connect the power supply to the input and set up 25 as monitored on the dvm. Adjust R8 for fsd on the meter and mark on the scale with Letraset or similar. The scale, you will remember, will need to have the existing numerals removed. The power supply is now set up for 20V, 15V, 10V, and 5V, and the corresponding points put in on the scale.

Having set the instrument for a basic sensitivity of 25V f s d , it is now possible to produce other ranges using the usual resistor divider chain, and I suggest ranges of 25, 50, 100, 250, and 500V. These cover the likely use on 110V, 240V, and 440V, supplies, and the ranges can be obtained using readily available preferred resistors if you copy the network shown in Fig. 5. Bear in mind that the resistor chain will become warm with prolonged use, so mount all the resistors as far away as possible from the heat-sensitive parts of the circuit.

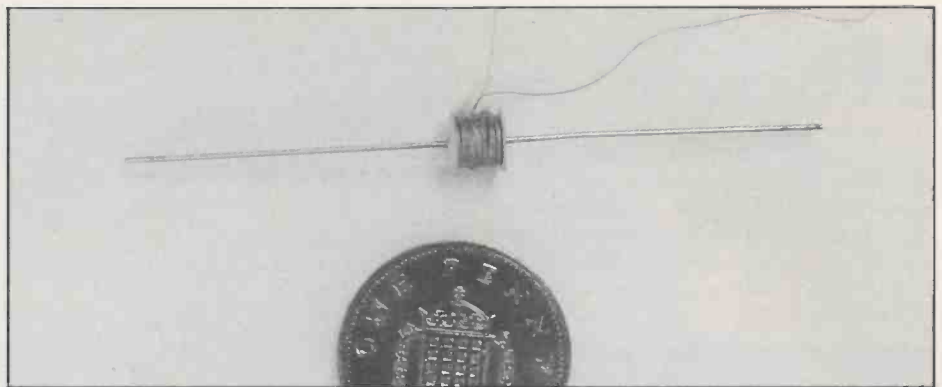

Fig 6. Completed heater coil (1p piece indicates size)

VOLTMETER USE

The instrument is as easy to use as any voltmeter, but you must bear in mind that it is intended for use in power electronics. The input current needed for f s d is 5mA on any range, and when measuring a circuit already taking 10 amps for instance the added load of 5mA is neither here nor there. What this instrument will *not* do is measure voltages where power levels are small and impedances are high.

Before use, and especially if you intend to 'float' the instrument, it is advisable to give an insulation test to make sure that the input is well isolated from the rest of the circuit, and the metal case. Most insulation testers (such as Megger) can give a 1000V test.

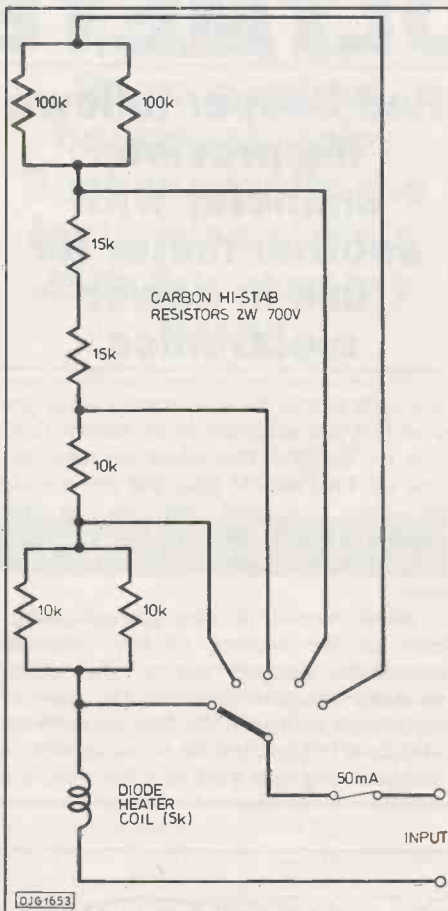

Fig 5. Range network giving 25, 50, 100, 250, 500.



Fig 7. Heater coil assembled with heat sinks on an aluminium plate for demonstration. Note tags for heater leadout wires and position of lower polystyrene insulator (top layer not yet in place).

INPUT PROTECTION

As with most test gear, overloads will occur from time to time even with the most careful user. With the ammeter, a fuse was used to prevent burn-out of the heater coil, but this method is not such a good solution to the problem with this voltmeter because 5mA fuses are just not available. The lowest commercial fuse I have seen has been 50mA, and this does not give sufficient protection to the input heater coil.

The circuit of Fig. 8 gives reasonable protection against most of the overloads likely to be encountered. It works like this; the normal maximum output from the ic is approximately 2 volts, (and if it is not, it should be adjusted to be 2V by altering the feedback resistor R5. If it rises to 3V then zener diode D1 conducts and the small-signal scr TH1 fires, energising the relay. The heater coil can easily withstand 3V, so no damage is done by this level of overload. The change-over contacts on the relay switch the input away from the heater coil and into a dump resistor R2. This resistor is required to lessen the possibility of a voltage higher than the

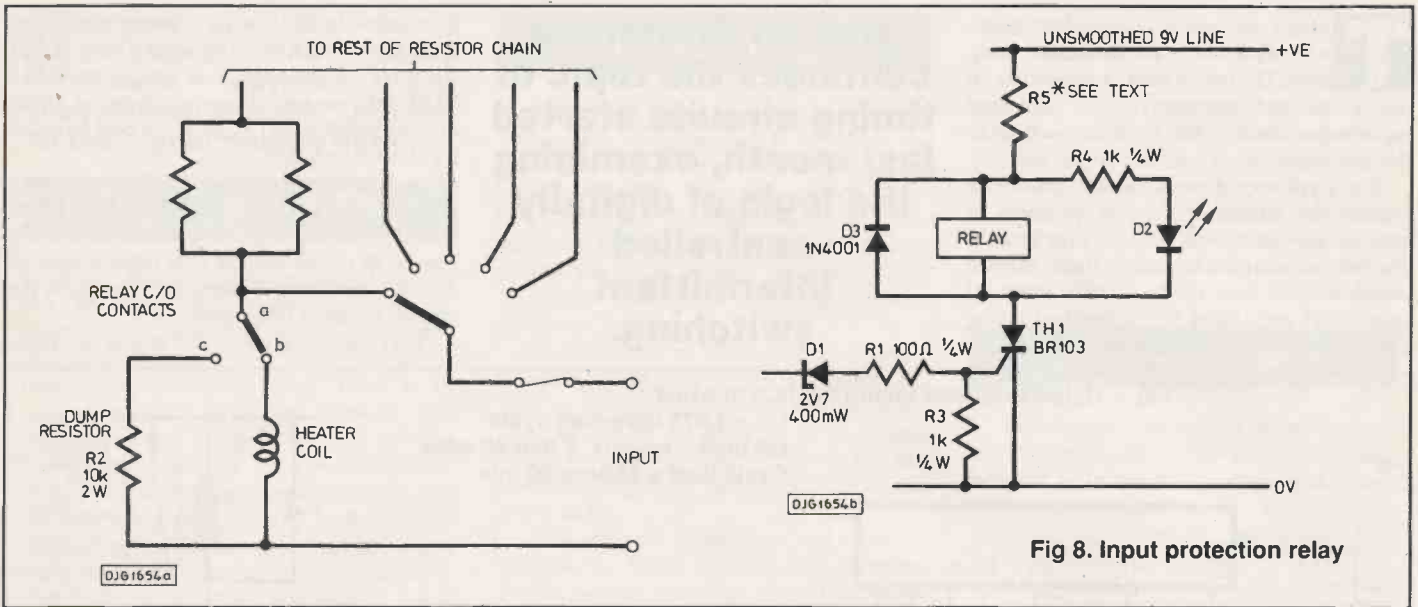

Fig 8. Input protection relay

blocking voltage of the contacts appearing across contacts a and b. The scr latches on, since the relay current is chosen to be higher than the holding current of the scr, and this means that there is no input to the heater coil even when the overload is removed.

Without latching, an overload could come and go without the user noticing, and this is never a good practice because damage could be done to the circuit under test with no apparent cause. Also, if the instrument is left unattended (feeding a chart recorder for example) a standing overload could cycle the relay indefinitely, and latching prevents this situation arising.

Indication of overload is given by led D2.

through to contribute to the heating effect in the input heater coil. A high crest factor cannot be claimed when back-to-back diodes are used.

COMPONENTS

D1	2.7V 400mW zener
D2	led
D3	1N4001
R1	100R 1/4 watt
R2	10k 2 watt
R3	1k 1/4 watt
R4	1k 1/4 watt
R5	choose to give approx 6V across relay coil when Th1 fires
Th1	small scr BR103
Relay	submin 6V c/o type

ARISING POINTS

Finally, there were a couple of errors in the June issue. Firstly, on page 50, the division line on one of the equations was missing, which must have been very puzzling for some readers: this was $E_{av} = \frac{V^2 T}{2R}$

Secondly, the term T was missing from the right hand side of the equation $\frac{V^2 T}{2R} = \frac{V_e^2 T}{R}$

OPERATIONAL NOTES

There are two facets of this system to be noted. Firstly, it will not operate if the instrument is turned off and an overload applied to the input. Secondly, it will not cope with a cataclysmic overload. A sudden enormous overload will damage the heater coil before the relay has time to operate, so a 50mA fuse in the input circuit is definitely a good idea.

Other forms of input protection used in more conventional instruments are not applicable. Back-to-back diodes for example would clip any spikes that might normally occur in proper operation. These should of course be allowed

THE DREADED VIRUS

The greatest current nightmare for anyone using a computer must surely be the fear of the system becoming infected by a virus. That nightmare recently became reality for us at Intra Press, and the production of all three magazines, *PE*, *Program Now* and *Astronomy Now* was severely threatened.

Eagle-eyed David Hewett, who is responsible for operating our sophisticated Macintosh DTP system, began to suspect that the software routines were not responding as fast as they should.

Prudently, he ran a virus-detecting software routine. To our horror it indicated a positive response - we were infected! A grand pow-wow ensued between David, *PN* editor Nigel Stuckey and *PN* technical editor Jon Lansdell. Thank heaven for the expertise of our sister magazine's analysts! They discovered the infection was by a less-virulent virus known as 'nVIR'. With the amount of material that comes through our offices, the virus might have originated from many sources. A bit more detective work, though, strongly suggested it had come in from Yugoslavia.

With diagnosis complete, a vaccine was provided by the Apple Centre at Chiswick, and administered to the sick system. "Apple today keeps the virus at bay", says the old proverb - and with due justification. Our DTP is fully restored to natural health, and not a sign of lethargy, even among the operators!

Newsagent Order Form

Dear Newsagent, I like reading Practical Electronics magazine. Please deliver/save one copy each month until further notice.

My name is
Address

Don't miss a single issue of PE! Make a firm order with your Newsagent!

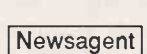

Though the circuit shown last month will work better than a design using only 555 type timers, it is possible to reduce cost and complexity while improving performance. Here is the reasoning leading to this conclusion:

It is intuitively obvious that one could gate together the outputs of the counter stages to generate waveforms with differing time periods. The basic requirement to achieve this is that the complete cycle time of the counter (from all zeros to all ones) must be the required timing cycle. In this case the figure is half an hour.

Andrew Armstrong continues the topic of timing circuits started last month, examining the logic of digitally controlled intermittent switching.

transistors, so that the logic output must be at logic 1 to switch on. The output is to be off for more of the time it is on, so choose a NOR gate because its output is at 0 if either or both inputs is at 1. This is the best function for the output gate.

Gating together Q9 and Q8 immediately gives a duty cycle of 4:12. It is then necessary to add logic to change this to 3:13. The NOR of Q9 and Q8 is at logic 0 most of the time, and logic 1 is required to inhibit the output, so invert this signal.

That uses three gates, and leaves one input

Fig 1. Gated extended timing method in which:

Q6 = 1.875 mins/half cycle
On time = approx 5 min 40 secs
Cycle time = approx 30 min

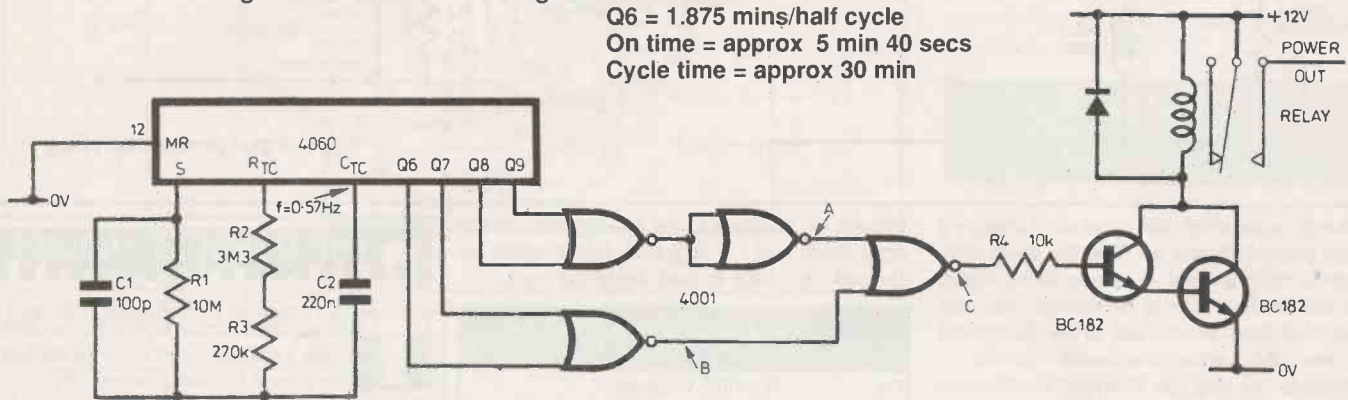

GATED TIMING

Considering only the ON times, the lowest frequency output is on for 15 minutes, the next one for 7.5 minutes, and so on. A very simple solution would be to gate together the final two counter outputs from last month's circuit to give a time period of 7.5 minutes. Such a simple requirement could be carried out by two diodes, but I would not say that 7.5 minutes is close enough to 5 minutes.

0100 AND COUNTING

To choose a time period to better than ± minute, four adjacent counter outputs are needed, with the lowest frequency output running at one cycle per half hour. The data book shows that the 4060 lacks a Q10 output, so that the lowest frequency outputs in a group of four are Q6 to Q9 inclusive. To produce the required frequency on Q9 requires a frequency of 0.57Hz on the oscillator, much lower than last month's design.

The oscillator design itself deserves mention at this point. The basic time constant is $(R2+R3) \times C1$, but this is affected by the loading of the diode protected CMOS inputs. Consequently R1 is added to minimise the spurious capacitor charging current which flows when the voltage on the bottom end of C1 is outside the power supply rails. Unfortunately the addition of this resistor leaves the input vulnerable to noise, so to make sure that the counter only receives one clock pulse per clock cycle rather than a double bounce, C1 is added.

Q9	Q8	Q7	Q6	A	B	C
0	0	0	0	0	1	0
0	0	0	1	0	0	1
0	0	1	0	0	0	1
0	0	1	1	0	0	1
0	1	0	0	1	1	0
0	1	0	1	1	0	0
0	1	1	0	1	0	0
0	1	1	1	1	0	0
1	0	0	0	1	1	0
1	0	0	1	1	0	0
1	0	1	0	1	0	0
1	0	1	1	1	0	0
1	1	0	0	1	1	0
1	1	0	1	1	0	0
1	1	1	0	1	0	0
1	1	1	1	1	0	0

Truth table for Fig. 1.

DECODING

The method of designing the decoding circuit is not totally obvious. Inspection of the counter truth table suggests that the function could be performed with a single CMOS IC, probably some sort of quad 2-input gate. The reasoning was as follows:

"The relay is to be driven by a pair of npn

of the output gate spare. What happens if I simply gate together Q7 and Q6 and feed the resulting signal to the output gate? (Adds three columns to truth table.) That works!"

The method of design is thus a combination of straight analysis, and drawing something out to see if its logic is correct. The same style of reasoning would apply to different timing requirements (and other types of problem) though in some complicated cases it might be easier to use two binary comparators to build a digital window comparator to determine the required range. It is more satisfying, however, to design a simple circuit which does the job well.

ABOUT ASK PE

Ask PE is a most-monthly column in which the most interesting readers' technical enquiry (in the opinion of the Editor) will be answered to the best of the columnist's ability. Individual queries will not be answered, even if stamped addressed envelopes are sent. The sole exception to this is that, when a column has been written, a photocopy of the material may, at the Editor's discretion, be sent to the questioner ahead of publication if an sae is enclosed. Please mark envelopes clearly "ASK PE", and enclose *no other correspondence* because these envelopes will be forwarded straight to the columnist.

PE

THERE IS SOMETHING IN THIS FOR EVERYBODY

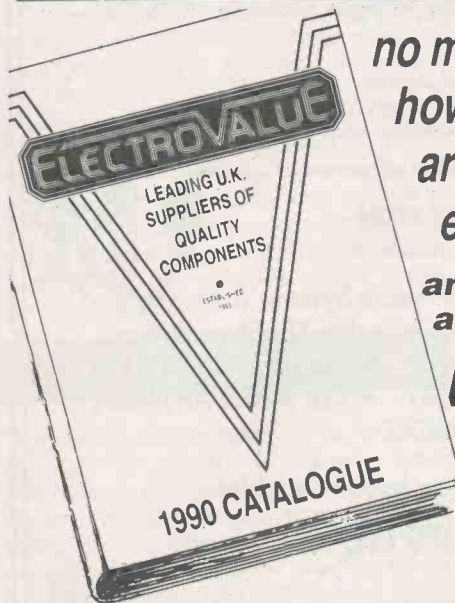

*no matter
how far you
are into
electronics
and it's
absolutely
FREE!*

PHONE
Englefield Green
0784 433 603
Fax 0784 435 216
Telex 264475

Manchester
061 432 4549
Fax 061 432 412

● ORDERS SENT POST FREE IN U.K.
● ACCESS/VISA FACILITIES
(min. order £5)

Head office/sales/Admin/Shop
28 St. Jude's Rd., Englefield Green, Egham
Surrey TW20 0HB. (0784 435 216)
Manchester
680 Burnage Lane, Manchester M19 1NA
(061 432 4945) (Fax 061 432 4127)

WRITE
Electrovalue Ltd
FREEPOST
28a St. Jude's Rd.,
Englefield Green,
Egham
Surrey TW20 8BR

Please mention this mag. when writing

GLOBAL ELECTRONICS

1 WINKLEY STREET
LONDON E2 6PT

The name for your components

ONLY QUALITY BRANDED COMPONENTS

LOW PRICES – NO MINIMUM ORDER

LARGE QUANTITY PRICING

HAVING PROBLEMS FINDING A
COMPONENT? – CONTACT US!

PHONE FOR OUR FREE CATALOGUE

10% OFF CATALOGUE PRICES WITH
THIS ADVERT!!

OFFER VALID UNTIL FEBRUARY 1990

NEW PRODUCTS BEING ADDED
CONSTANTLY

PHONE: 01-739 8199

Our very simple offer to hobbyists

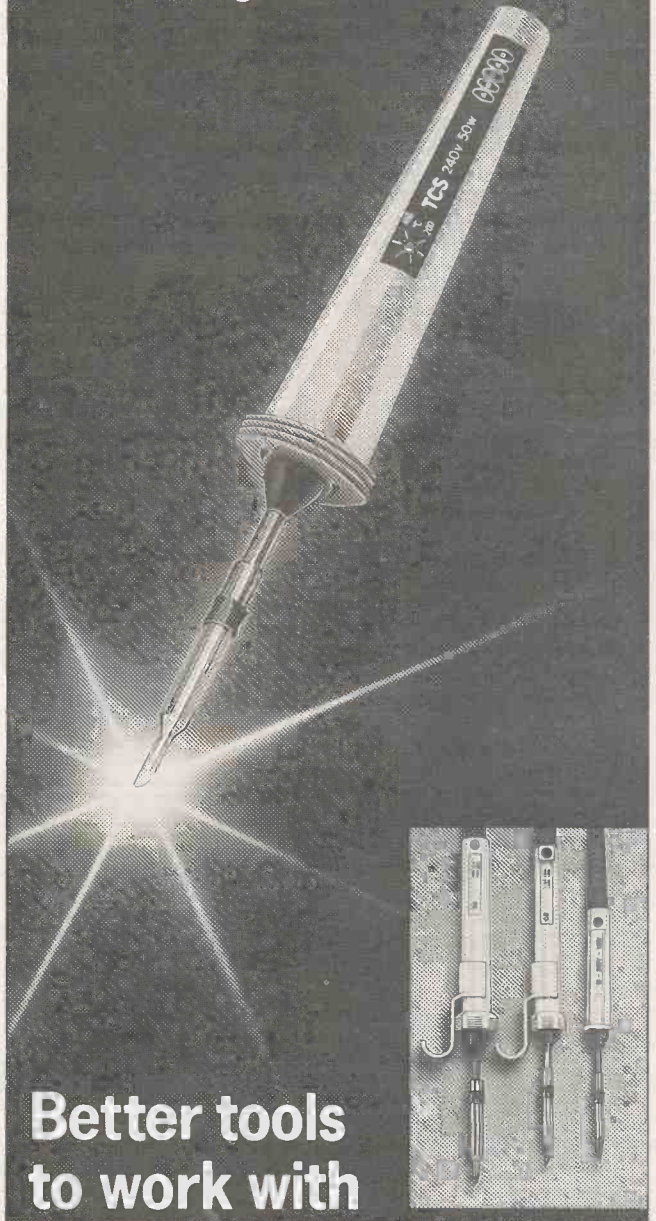

Better tools to work with

● Antex TCS 240V 50W and
TCS 24V 50W.

● Temperature Controlled Soldering Irons for electronic and electrical applications – an essential item in the hobbyist's tool kit.

● Temperature range 200° to 450° C. Analogue proportional control $\pm 1\%$. Max. temperature achieved within 60 seconds.

PLUS

● Antex M-12W; CS-17W; and XS-25W. Available in 240 or 24 volt.

● Tools specially designed for fine precision soldering.
Ideal for all electronics craftsmen and hobbyists.

For full information on the comprehensive Antex range of soldering irons, power supply units and accessories, please clip the coupon.



Antex (Electronics) Limited, 2 Westbridge Industrial Estate, Tavistock, Devon PL19 8DE. Tel: 0822 613565. Fax: 0822 617598. Telex: 9312110595 AE G. Please send me full details of the full range of Antex soldering products.

Name _____

Address _____

Postcode _____ (PE 1)



Established since 1973 Hills Components can offer the trade a selection of nearly 4,000 product lines covering the following ranges

- Aerials & Accessories
- Batteries & Accessories
- Cables & Accessories
- Computer Accessories
- Connectors (all types)
- Electronic kits/Modules
- Filters/Fuses
- Hardware/Fixings
- Headphones/Intercoms
- Connecting leads (all types)
- Microphones
- Multimeters
- Passive Components
- P.C. Boards
- Relays
- Speakers
- Switches
- Service Aids
- Soldering Equipment
- Telephones & Accessories
- Transformers

TRADE ENQUIRIES ONLY

Please phone or write quoting your company name & address for a copy of our 1990 catalogue

TRADE ONLY

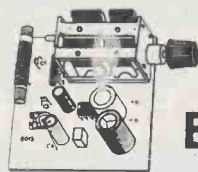

ELECTRONIC KITS & MODULES

FOR HOBBYISTS ELECTRONICS ENTHUSIASTS EDUCATIONAL ESTABLISHMENTS ETC.

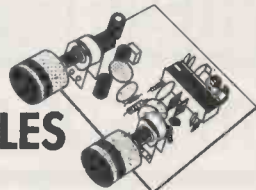

Build your own:
Geiger-Mueller Indicator, Metal Detector, Stereoa Amplifier Digital Combination Lock, or any of the many other kits available for numerous applications

Each kit comes in component form with easy to follow instructions for assembly

OVER 100 KITS TO CHOOSE FROM

Some of the popular kits include

- * Antenna Amplifiers
 - * Lie Detectors
 - * Alarm Systems & Monitors
 - * Infra-Red Light Barriers
 - * Sirens - Kojak-Warship-FBI-Ships-Space
 - * Micro-Wave Indicators
 - * Radios & Receivers
 - * Electronic Barking Dog
 - * Lighting Consoles
 - * Amplifiers (up to 200w)
 - * Car Aerial Amplifiers
- PLUS MANY MANY MORE**

Call us now for details of your local Stockist

HILLS COMPONENTS LTD

Units 5 & 6
Melinite Industrial Estate
Brixton Road, Watford
Herts WD2 5SL
0923 52000

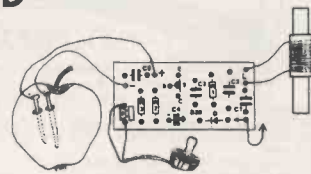
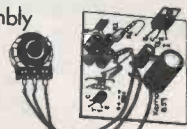
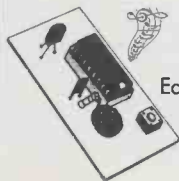

WE HAVE THE WIDEST CHOICE OF USED TELESCOPES IN THE COUNTRY

H.P. 174A Dual Trace 100MHz Delay Sweep...	£500
TELEQUIPMENT 083 Dual Trace 50MHz Delay Sweep...	£300
GOULD OS300A Dual Trace 40MHz Del. Sweep TV Trng...	£300
TELEQUIPMENT D755 Dual Trace 50MHz Delay Sweep...	£275
KIKUSUI 5530A Dual Trace 35MHz	£250
COSSOR COU150 Dual Trace 15MHz Delay Sweep...	£180
GOULD OS1100 Dual Trace 10MHz TV Trng	£210
S.E. LABS SM111 Dual Trace 15MHz	£130
TRIO CSI 568A Dual Trace 20MHz	£250
H.P. 1220A Dual Trace 15MHz TV Trng	£200
GOULD OS255 Dual Trace 15MHz TV Trng	£210
PHILIPS PW3233 Dual Beam 10MHz TV Trng	£200
GOULD OS255A Dual Trace 10MHz TV Trng	£140

THIS IS JUST A SAMPLE - MANY OTHER AVAILABLE

MARCONI SANGERS 65888 Sig Source 8 - 12.5MHz	£650
MARCONI TF2008 AM/FM 100KHz - 510MHz Sig Gen	£375
MARCONI TF2015 AM/FM 10-520MHz Sig Gen with TF2171	£550
MARCONI TF2015 without Synchroniser TF2171	£425
MARCONI TF2016 AM/FM 100KHz-120MHz Sig Gen with TF2173	£400
MARCONI TF2016 without Synchroniser TF2303 from	£300
DYMAR 1525 AM/FM 0.1 - 184 MHz Sig Gen	£200
H.P. 620B Signal Generator 7-11 GHz	£400
H.P. 618C Signal Generator 3.8-7.6 GHz	£400
H.P. 618B Signal Generator 1.8-4.2GHz	£400
FERRORGRAPH RTS2 Recorder Test Set	£275
WOLKE Low & Fxkter Meter ME108	£100
LEADER LMV185A Two CHANNEL Millivoltmeter	£100
5MHz-500KHz 100 Ohm - 300V	£120
FEEDBACK FG601 Sig Gen 0.001Hz-1MHz Sine/Sq/Tri	£150
MARCONI Automatic Clibration Meter TF2337A 400Hz or Measures down to 0.01%	£100
LEVELL OSCILLATORS TG152/TG200 series from	£ 95
MARCONI TF2700 UNIVERSAL LCR BRIDGE. Battery from	£150
PHILIPS PW6456 FM Stereo Generator	£ 95

HAMEG MODULAR SYSTEM

HM3001 Main Frame with HM8032 Sine Wave Generator 20Hz - 20MHz	£375
HM8032 Function Generator 0.1 - 1MHz Sine/Sq/Triangle and HM8011.2 Digital Multimeter 4.5 digit	£375
SADELTA WC321 COLOUR BAR GENERATOR RF Bands 1/3/4 & Video Sound Carrier. Unused (P&P £7)	£125
SADELTA COLOUR BAR GENERATOR PAL WC101, 8 PATTERNS Pocket Size, Rechargeable Bact. Complete with Battery Charger Adaptor. Unused(P&P £4)	£50
DECOARTORTING Colour Bar GENERATOR type 62514	£125
Lighthouse Colour Bar Generator K31. 8 test Patterns (P&P £4) only	£40
LABSEAR FIELD STRENGTH METERS	£10 (P&P £7)
LABSEAR CROSSHATCH GENERATOR Type CM6038-DB Cross-hatch Grey Scale/Blank Reser. Mains or BATTERY. Unused £18. Used £12 (P&P £3)	£18
TRIO RF SIGNAL GENERATOR Type SG402 100KHz-30MHz Unused (P&P £7)	ONLY £50
ADVANCE SG628 AM 150kHz-220MHz	£45 (P&P £7)

TELEPHONES - YES! REAL DIAL TYPE TELEPHONES - that don't slide around the desk. Type No. 746 supplied with standard BT plug (Used)..... Only £5 each. Quantity discount

Used equipment - with 30 days guarantee. Manuals supplied, if possible. This is a VERY SMALL SAMPLE OF STOCK. SAE or Telephone fol Lists. Please check availability before ordering. CARRIAGE all units £16. VAT to be added to total of Goods & Carriage.

STEWART OF READING

110 WYKEHAM ROAD, READING RG6 1PL, BERKS RG6 1PL
Tel: 0734 68041 Fax: 0734 351696
Callers welcome 9 am - 5.30 pm (until 8 pm Thursday)

TEKTRONIX OSCILLOSCOPE 2235 Dual Trace 100MHz Delay Sweep	£750
PHILIPS OSCILLOSCOPE PM3217 Dual Trace 50MHz Delay Sweep	£500
GOULD OS300 Oscilloscope Dual Trace 20MHz	£250
GOULD 1421 Digital Storage Dual Trace 20MHz	£750
THANDAR PL3200MD 0-30V 2A Twice, Quad Mode Digital Meters	£200
FEEDBACK FSG 805 Sweep Function Generator QD1Hz - 1MHz (P&P £7)	£125
SOLARTRON 7645 Multimeter 44 digit LED 30 ranges AutoManual (P&P £7)	£18
LOGIC PROBE type 3300A TTL CMOS. (P&P £3)	£18
FARNELL Oscillator LFM3 10Hz-10MHz Sine/Square	£200
RACAL 9915 Pres Counter 10Hz-520MHz (Crystal Over)	£150
RACAL 9900 Series Universal Counter Timers	£150
MARCONI ATTENUATORS TF2162 DC-1MHz 800 ohm. G-1116B (P&P £7)	£35
HATFIELD ATTENUATORS 50 ohm DC-250MHz 0-100dB/800 ohm DC-1MHz (New Price £135) (P&P £4) ONLY £50	

AVO MULTIMETERS (P&P 10 all)

Avo 85, 85 and Ministry Versions. With Batteries & Leads	from £50
TEST LEADS for Avo's. Red & Black with 2 croc Clips & 2 prongs	
	(P&P £3) £5
Black EVER READY Case for Avo's. Un-used	£15
BATTERIES 15Volts	£3 each, 10 for £25 (P&P extra)

AVD TRANSISTOR ANALYSER W4. CT446 outcase style. With Batteries & operating instructions. ONLY £25 (P&P £7)
MARCONI AF Power Meter TF893A 20Hz-35KHz 20mW - 10W. With Manual. ONLY £25 (P&P £7)
MARCONI RF Power Meter TF1152AM. DC-500MHz 0.5 - 25W. 50 ohm With Manual. ONLY £30 (P&P £7)

NEW EQUIPMENT

HAMEG OSCILLOSCOPE HM1005 Triple Trace 100MHz Delay Timebase	£726
HAMEG OSCILLOSCOPE HM 604 DUAL TRACE 60MHz Delay Sweep	£375
HAMEG OSCILLOSCOPE HM 203 6 Dual Trace 20MHz Component Tester	£314
HAMEG OSCILLOSCOPE HM205. 2 Dual Trace 20MHz Digital Storage	£527

All other models available & all oscilloscopes supplied with 2 probes

BLACK STAR EQUIPMENT (P&P all units £5)
APOLLO 10 - 100MHz Counter Timer Ratio/Period/Time interval etc... £222
APOLLO 100 - 100MHz (AS above with more functions) £295
METEOR 100 FREQUENCY COUNTER 100MHz £ 99
METEOR 600 FREQUENCY COUNTER 600MHz £126
METEOR 1000 FREQUENCY COUNTER 1GHz £178
JUPITER 500 FUNCTION GENERATOR 0.1Hz-500KHz Sine/Sq/Tri. £110
ORION COLOUR BAR GENERATOR Pal/TV/Video £209
All other Black Star Equipment available.

HUNG CHANG OHM 7030 3 1/2 digit, Hand held 28 ranges including 10Am/AC/DC 0.1% Acc. (P&P £4) £39.50
As above OHM 6010. 0.25% Acc. £33.50
Carrying Cases for above. £ 3

OSCILLOSCOPE PROBES Switchable x1; x10. (P&P £3) £11

electronize Car Electronics

MICRO-PRESSURE CAR ALARM

This new type of alarm is triggered by a unique pressure sensing system. As any vehicle door is opened, air is drawn out, causing a minute drop in air pressure. A sensor detects this sudden pressure change and sets off the alarm.

A sophisticated arrangement of electronic filters and timers provide features to match ultra-sonic systems but at a fraction of the cost.

- * 1 Micro-Pressure intruder detection.
- * 2 Operates on all doors and tailgate.
- * 3 No door switches needed.
- * 4 Automatically armed 1 minute after leaving vehicle.
- * 5 10 second entry delay with audible warning.
- * 6 Sounds horn intermittently for 1 minute.
- * 7 Easy fitting - only 3 wires to connect - no holes to drill.
- * 8 Compact design can be hidden below dashboard.
- * 9 All solid state Power MOSFET output - on relays.

MICRO-PRESSURE ALARM KIT	£12.95
ASSEMBLED READY TO FIT	£18.95

VOLT DROP CAR ALARM

Our latest alarm using the popular voltage drop method of triggering. Based on the timers of the micro-pressure alarm it offers features 4 to 9 above but relies on the existing door switch operation for triggering.

VOLT DROP ALARM KIT	£11.75
ASSEMBLED READY TO FIT	£17.75

TOTAL ENERGY DISCHARGE IGNITION

Our long established Extended CDI system retains the contacts to allow easy fitting whilst the electronics removes the adverse effects. The unique spark generating system still out performs the latest all electronic systems.

TOTAL ENERGY DISCHARGE IGNITION	£18.95
ASSEMBLED READY TO FIT	£24.90

All Electronize kits include clear, easy to follow instructions, quality components and everything needed, right down to solder and heatsink compound.

Order direct (Please quote Ref. H01 and add or send for more details from:- £1 post and packing per item.)

ELECTRONIZE DESIGN tel. 021 308 5877

2 Hillside Road, Four Oaks, Sutton Coldfield, B74 4DQ

Last month we looked at "faithful readings" and errors of misapplication and frequency.

PERIOD MEASUREMENT

Period error = ± 1 count
 \pm time base error
 \pm trigger error

The measurement of signal period uses the same circuitry as that used for frequency measurement; however, when measuring period, the input signal itself produces the gating signal, such that the gate time equals the input period t_p , and the pulses counted during this time are generated by the time base (see Fig. 9 and compare with Fig. 7).

Just as with frequency measurement, the lack of phase coherence between the gating signal and the counted clock pulses means that we again have a ± 1 count uncertainty in the reading. This time, however, the ± 1 count corresponds to ± 1 clock period, and so

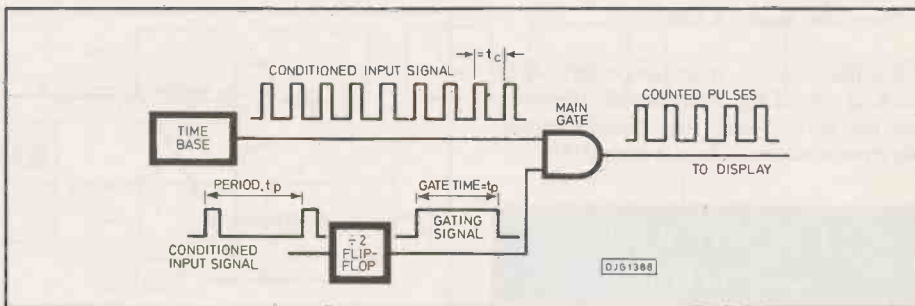

Fig.9 Basic period measurement scheme.

In the example of Fig. 10, the gate should normally be opened at point A, but the noise spike causes it to open too early (at point B) by the amount t_e seconds.

If we denote the noise amplitude by V_n , it can be seen that:

$$\frac{V_n}{t_e} = \frac{dV}{dt}, \text{ and rearranging: } t_e = \frac{V_n}{dV/dt}$$

Consequently, the trigger error is given by:

$$\text{Trigger Error, TE} = \pm 2t_e = \pm 2V_n \text{ seconds,} \\ \frac{dV}{dt}$$

zero). Consequently, when making time measurements, it is always best, wherever possible, to choose signals with very fast rise and fall times.

For sinewaves, the trigger points should be located at zero-crossings, since the sinusoid's slew rate is largest here. We can calculate the magnitude of the trigger error for a sinewave with, say, a 40dB signal-to-noise ratio, as follows:

$$\text{Input signal, } V = V \sin 2\pi ft; \\ \text{differentiating: } \frac{dV}{dt} = 2\pi fV \cos 2\pi ft.$$

UCT MEASUREMENTS

the quantisation error contribution is simply $\pm t_c$, where t_c = one clock period.

Furthermore, since the counted clock pulses are derived from the time base oscillator, we must remember to include the \pm time base error in the assessment of the total period error.

So far, the error sources are similar to those for frequency measurement. However, we must also consider one more, namely 'trigger error'.

Trigger error is a random error caused by noise on the input signal and noise inherent in the counter's input circuitry. For our purposes, we will ignore circuit noise since it is usually much smaller than signal noise.

In both period and time interval measurements, the input signal(s) controls the opening and closing of the main gate; thus, any noise on the signal will cause the hysteresis threshold to be crossed either too soon or too late, leading to a distortion of the gate time.

Fig.10 Noise causes trigger error.

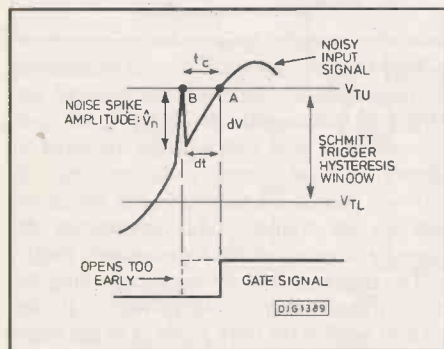

PART TWO BY ANTHONY H. SMITH BSc

For anyone with an expensive counter-timer it's vital to understand it correctly and avoid the pitfalls.

where dV/dt is simply the slew rate of the input signal at the trigger point. We must include the factor ± 2 because the noise may cause the gate to:

- open early and close late: $TE = +2t_e$,
- or: open late and close early: $TE = -2t_e$.

It is quite possible, of course, for the gate to open early and close early, or open late and close late, such that the error 'cancels itself out'. However, when specifying errors we must deal with worst-case possibilities, such as those above.

We see immediately from the expression for TE that this error can be minimised by reducing the input signal noise, and/or increasing the signal slew rate. (Indeed, you may be wondering why trigger error is not included in the error specifications for frequency measurement. This is because the main gate is controlled by digital signals derived from the time base, which - theoretically at least - are noiseless, and have infinite slew rate, thus reducing TE to

This is a maximum at the zero-crossing of the input sinewave, where $\cos 2\pi ft = 1$, ie, $\frac{dV}{dt} \text{ MAX} = 2\pi fV$. Thus, $TE = \pm \frac{2V_n}{2\pi fV}$

and since the SNR = 40dB, we know that $V_n = 0.01V$. Hence:

$$TE = \pm \frac{0.01}{\pi f} = \pm \frac{0.003}{f} \text{ seconds.}$$

We can specify the trigger error time as a percentage of the period itself, as follows:

$$\text{Percentage Error} = \frac{TE}{\text{PERIOD}} \times 100 = \frac{TE \times 100}{f} \times 100$$

$$= \pm \frac{0.003}{f} \times f \times 100 = \pm 0.3\%$$

Thus, the trigger error can be as large as 0.3% of the period itself. This is quite a substantial error, and we can see how it affects the overall period error in the following example:

EXAMPLE:

Input Signal = 100kHz sinewave, 40dB SNR.

Time Base Oscillator Nominal Frequency = 10MHz.

Time Base Oscillator Frequency Error = $\pm 8.8 \times 10^{-6}$.

Quantisation error component = $\pm t_c = \pm 100\text{ns}$.

Time Base error component = $\pm 8.8 \times 10^{-6} \times \text{PERIOD} = \pm 8.8 \times 10^{-6} \times 10\mu\text{s}$

= ± 88 picoseconds (which is negligible!)

Trigger error component = $\pm 0.3\%$ of PERIOD = $\pm 0.03\mu\text{s} = \pm 30\text{ns}$.

Thus: total error = $\pm 130\text{ns}$.

For this example, quantisation error is as much as 1% of the input period. However, had the period been, say, 10 milliseconds, this error would have been a mere 0.001%.

RECIPROCAL COUNTERS

We see from the above example that quantisation error is the dominant factor only when measuring short periods (ie, for high frequencies), whereas for frequency measurements, this error dominates only at low frequencies.

For example, assume we wish to determine the exact mains supply frequency. In frequency mode, using a 1 second gate time, the reading will simply be 50Hz, ie, we can measure the frequency with a resolution of 1Hz. The quantisation error as a percentage of the input frequency will be:

$$\text{Percentage Quantisation Error} = \pm \frac{1}{\text{FREQUENCY}} \times 100 = \pm \frac{1}{50} \times 100 = \pm 2\%$$

If we now switch to period mode and find that the display reads, say, 19.9970 milliseconds, we can determine the frequency simply by taking the reciprocal:

$$\text{Frequency} = \frac{1}{\text{PERIOD}} = \frac{1}{19.9970 \times 10^{-3}} = 50.0075\text{Hz}$$

(Note the improved resolution).

The percentage quantisation error (assuming a clock period of $t_c = 100\text{ns}$) is simply:

$$\text{Percentage Quantisation Error} = \pm \frac{t_c}{\text{PERIOD}} \times 100 = \pm \frac{100 \times 10^{-9}}{19.9970 \times 10^{-3}} \times 100 = 0.0005\%$$

Obviously, we can dramatically improve both resolution and accuracy by making a period measurement and then taking the reciprocal. A reciprocal counter works in the same way: first, the input period is measured, then arithmetic circuits compute the reciprocal which forms the required frequency display.

To ensure that quantisation error is minimised even when measuring high frequencies, most reciprocal counters use a method known as 'multiple period averaging' which maintains high accuracy and optimum resolution at all frequencies (we will examine this powerful technique in the next part).

The reciprocal measurement technique is also ideally suited to making burst frequency measurements. Fig. 11 shows a typical burst frequency signal.

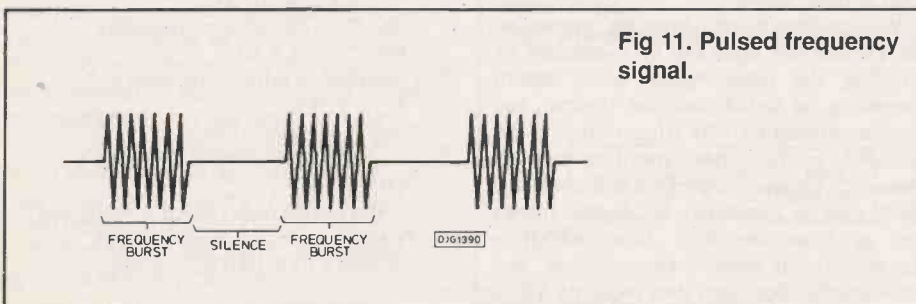

Fig 11. Pulsed frequency signal.

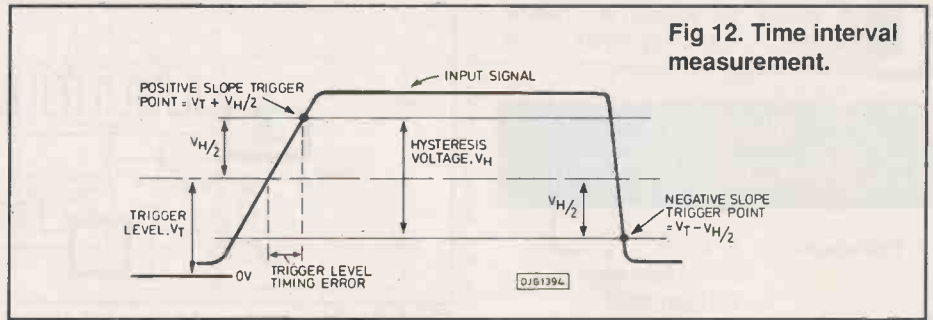

Fig 12. Time interval measurement.

Using the conventional frequency mode, the cycles occurring during the frequency burst are accumulated as normal, but the displayed reading will be totally incorrect due to the absence of cycles during the 'silent' period.

The reciprocal counter, however, starts the measurement with the first cycle of the frequency burst, measures its period, and then displays the correct frequency: the silent periods thus have no effect on measurement accuracy.

TIME INTERVAL ERRORS

Time interval error = ± 1 Count

- \pm Time base error
- \pm Trigger error
- \pm Systematic error

Like period measurement, a time interval reading suffers from quantisation error, time base error, and trigger error, although the latter must be specified slightly differently to account for possible differences in slew rate at the 'start' and 'stop' inputs:

$$\text{Trigger Error} = \pm \frac{(\text{Peak Noise Voltage on Start Signal})}{\text{Start Signal Slew Rate}}$$

$$+ \frac{(\text{Peak Noise Voltage on Stop Signal})}{\text{Stop Signal Slew Rate}}$$

The additional 'systematic' error actually covers two new sources of error, namely 'differential channel delay' and 'trigger level timing error'.

The time interval measurement scheme is represented in Fig. 12, where the start signal sets the flip-flop, thus opening the main gate, and the stop signal resets the flip-flop which closes the main gate.

It takes time for each input signal to propagate through the probe cable and conditioning circuitry; consequently, the start and stop channels have small, but finite, propagation delays. Any difference in these delays gives rise to the differential channel

delay error. For example, if the start channel delay is 8ns, and that of the stop channel is 10ns, the difference will set the flip-flop 2ns too early, causing a corresponding erroneous increase in the gating signal.

When measuring time intervals of 10 μs or more, such errors are usually small enough to be negligible. However, several high performance counters such as the Hewlett Packard HP5345A can measure single time intervals as short as 2ns, such that the differential channel delay can no longer be ignored and must be removed.

This is no easy matter, however, and requires that the conditioning circuits be fitted with special variable delay elements which can be trimmed so as to equalise the propagation delays. Furthermore, the probe cables must be exactly the same length: a difference of just one inch is enough to introduce a differential delay of around 9.1ns.

Unfortunately, even if we manage to remove the differential channel delay, we must still contend with the trigger level timing error.

If all input signals were clean, sharp pulses, trigger level timing error would not exist. In practice, however, all signals have a particular slew rate; for pulses, this means finite rise and fall times, and indeed, the time interval mode is often used to measure these parameters.

Fig 13. Time interval mode measures rise time.

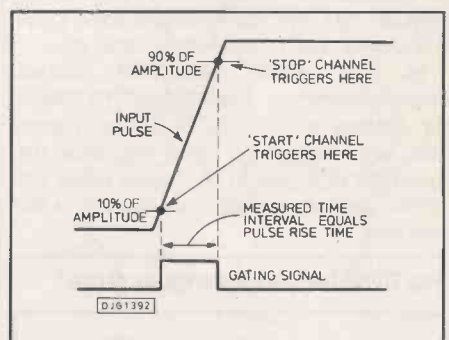

Fig. 13 shows how rise time is determined by measuring the time interval between the 10% and 90% amplitude points. Since both the start and stop channels are required to trigger on the same waveform but at different points, the accuracy with which we can set the trigger points determines the ultimate accuracy of the measurement itself.

The trigger points are set by adjusting the uct's trigger level potentiometer. If the control knob is the only guide as to the value

of the trigger level, it is almost impossible to set the trigger points accurately, even if the control has a calibrated scale.

Those counters which feature signal monitor and trigger monitor outputs allow the conditioned input signal and Schmitt trigger output to be superimposed on an oscilloscope screen; the point where the waveforms cross is the apparent trigger point (Fig. 14).

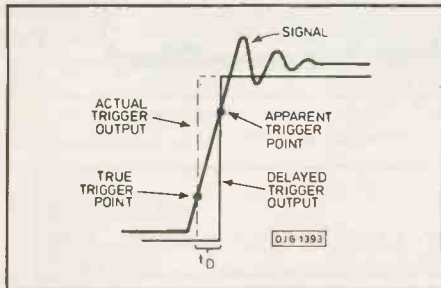

Fig 14. Problems in setting trigger point.

For measurements above a few microseconds, this technique provides a reasonably accurate means of setting the trigger points.

Unfortunately, when dealing with very short time intervals, delays within the counter which result in the trigger output being delayed relative to the signal output by the amount t_D , cause the apparent trigger point to be substantially different from the true trigger point.

In fact, correct setting of the trigger points can only be accomplished if the trigger level voltage itself can be read from the instrument panel. However, even this has its limitations. Fig. 15 shows that if we assume (incorrectly) that triggering occurs at the trigger level, we will incur a trigger level timing error given by:

$$\text{Trigger Level timing Error} = \frac{\text{Half Hysteresis Voltage } (=V_H/2)}{\text{Signal Slew Rate at Trigger Point}} \quad \text{seconds}$$

Since triggering occurs at the trigger points, rather than at the trigger level, we must bear in mind that:

Positive Slope Trigger Point
Voltage = $V_T + V_H/2$,

and: Negative Slope
Trigger Point Voltage = $V_T - V_H/2$.

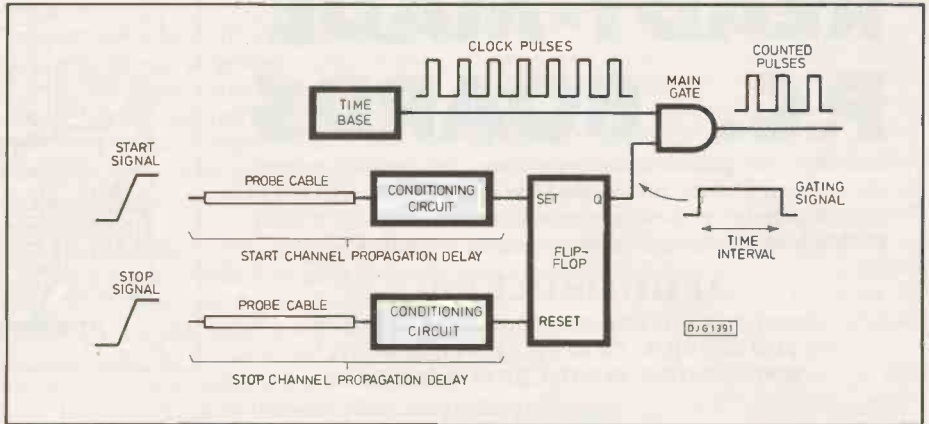

Fig 15. Trigger level timing error (shown for positive slope).

Take care, however, if the input signal has been attenuated: for example, if we attenuate the input by a factor of x10, a trigger level of, say, 0.5 volts corresponds to a trigger level of 5 volts relative to the signal itself.

Incidentally, provided the input pulses are large enough to trigger the counter's input correctly, the 'totalise' mode of measurement (sometimes called 'events counting') will suffer no error at all, and will simply continue to accumulate all input events as they occur. However, it is arguable that this mode is not a true form of measurement, since the input signal is not being compared with any reference standard.

In the next article, we shall look at a special averaging technique used to minimise random errors, and at several unusual techniques employed to extend the range of the basic unit. PE

SUMMARY

Fig. 16 summarises the errors associated with each type of measurement.

Remember that any additional modes (such as Pulse Width, Rise/Fall Time, and Phase Measurement) which rely on a time interval measurement are likely to suffer from all sources of error.

Fig 16. Summary of errors associated with each type of measurement.

Measurement Mode	Frequency	Period	Time Interval
Types of Error			
±1 Count (A Random Quantisation Error)	✓	✓	✓
± Time Base Error	✓	✓	✓
± Trigger Error (A Random Error)		✓	✓
± Systematic Error			✓

PROGRAM

THE PROFESSIONAL SOFTWARE DEVELOPERS' JOURNAL *NOW*

NOVEMBER ISSUE OUT NOW!

In this issue:

- ☆ Writing a Compiler ☆ File Handling in Fortran ☆
- Widows dBases Head to Head ☆ Plus our regular news, book reviews, The Analyst and more!

Available from all good newsagents - £1.50

Published by Intra Press - Publishers of Practical Electronics

SOFTMACHINE DISTRIBUTION LTD

386 MOTHER BOARDS

16/20MHz 386 M/B
16/20MHz 286 M/B
VGA CARD

Ex-stock Cash & Carry, from Computer Casing Specialist
Trade Hours: 10-6pm (Sat 10-1pm)

SOFTMACHINE DISTRIBUTION LTD.
Unit F, 18 Harbet Rd, Lea Valley, Hastingwood Trading Estate,
North Circular Rd, Edmonton, London N18 3LR
Fax: 01-807 2748 Tel: 01-803 6068

DEMS ONLY

READY-MADE P.C. BOARDS

Simplify your project assembly – use a ready-made printed circuit board. All are fully drilled and roller tinned. Just slot in the components as shown in the project texts, and solder them. PCBs are the professional route to project perfection.

MAIL ORDERING

Select the boards you want, and send your order to
**PE PCB SERVICE, PRACTICAL ELECTRONICS,
193 UXBRIDGE ROAD, LONDON W12 9RA.**

Prices include VAT and postage and packing. Add £2 per board for overseas airmail. Cheques should be crossed and made payable to Intra Press.

Quote the project name and PCB Code Number, and print your name and address in Block Capitals. Do not send any other correspondence with your order.

TELEPHONE ORDERS (OPEN 24 HOURS)

Use your Access card and phone your order to

0268 289923

clearly stating your name and address, card number, and order details.

All orders receive priority attention, but allow 28 days for delivery in case a PCB is temporarily out of stock.

WE CAN ONLY SUPPLY THE PCBs LISTED HERE

CHECK LATEST ISSUE FOR PRICES BEFORE ORDERING

PHOTOCOPIES OF THE TEXTS MAY BE BOUGHT FROM THE EDITORIAL OFFICE AT £1.00 EACH PART (£1.50 OVERSEAS), P&P INCLUSIVE.

COMPONENTS ARE AVAILABLE FROM ADVERTISERS.

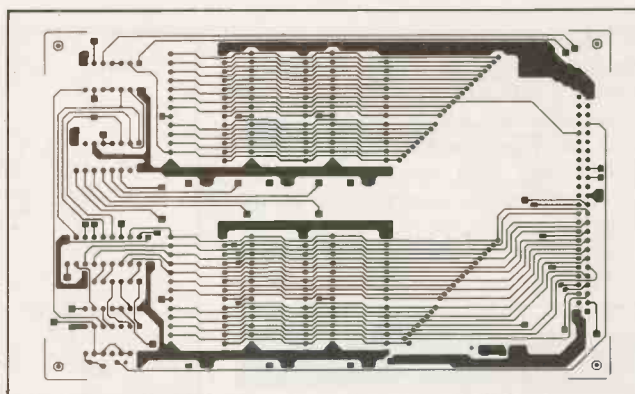

MAR 87			
4 CHANNEL ENHANCER	135	£4.60	
LIGHT PEN – uses fibre optics for accuracy	136	£4.10	
ULTRASONIC TAPE MEASURE	138	£9.50	
APR 87			
VIGILANTE CAR ALARM – keeps cars alert	139	£5.90	
INDUCTIVE LOOP TRANSCEIVER – remote control for models:	143/144	£7.80	
MAY 87			
BRIGHT FUZZ – Foot operated overdrive	145	£3.90	
JUN 87			
AUDIO SIGNAL GENERATOR	146	£10.20	
JUL 87			
WORD GENERATOR – 16-bit binary words	147	£13.42	
SCOPE STORE oscilloscope add-on data storage	148	£11.94	
SEP 87			
SPEECH PROCESSOR – clarifies speech	150	£5.86	
GCSE TIMER UNIT – versatile variable delay	151	£5.18	
FUNGEN – triple waveform signal generator	152/153	£9.69	
LIGHT CONTROLLER – delayed switching	154	£4.64	
OCT 87			
TEACHER LOCKER – digital lock control	155	£7.50	
POWER SUPPLY – stabilised ±15V	156	£7.50	
GUITAR TO SYNTH – music interface	157A/B	£9.95	
NOV 87			
DUAL POWER SUPPLY – GCSE	158	£6.20	
MIDI EXPANDER – Music Interface	159	£5.04	
DEC 87			
RS 232C TO MIDI	160	£6.43	
TEACHER RADIO – GCSE	161	£5.58	
JAN 88			
LEGO BUGGY DRIVER	163	£6.42	
FEB 88			
TEACHER TALKBACK – GCSE	164	£6.36	
DC MOTOR SERVO	165	£7.53	

MAR 88			
APPLIANCE TIMER	166A/B	£9.38	
TEACHER LIGHTSHOW – GCSE	167A/B	£9.09	
LOGIC ANALYSER – Double-sided	168	£20.65	
APR 88			
LIGHT METAL EFFECTS	169	£7.10	
TEACHER COUNTER	170	£4.95	
	171	£4.92	
MAY 88			
RF SPEECH PROCESSOR	172	£6.26	
JUN 88			
AMSTRAD ROM EXPANSION	173	£10.80	
MAINS MODEM	174	£4.27	
JULY 88			
VOCALS ELIMINATOR	175	£4.31	
AUGUST 88			
SPEAKING CLOCK	176	£16.75	
SEPT 88			
BBC MULTIPLEXER	177	£4.50	
OCT 88			
METAL DETECTOR	178	£6.50	
DEC 88			
PLD PROGRAMMER	179	£9.90	
	180	£4.90	
PANNING MIXER	181	£7.80	
JAN 89			
RUDOLPH'S NOSE	182	£6.25	
ANGEL'S HALO	183A/B	£9.40	
CANDLE FLICKER	184	£6.25	
MAR 89			
CAMERA SHUTTER TIMER	187	£9.95	
APR 89			
PC MULTIPORT	188A/B	£20.55	
MAY 89			
KIRLIAN CAMERA	189A/C	£10.50	
JUN 89			
SOLAR HEATING CONTROLLER	197	£7.20	
DELUXE METRONOME	198	£10.95	
JULY 89			
PROJECTOR SYNCHRONISER	190-E	£9.50	
AUG 89			
EASI-BUILD – VODALEK	191	£4.90	
HAND CLAPPER	192	£6.50	
SEP 89			
EASI-BUILD – COMPRESSOR	193	£4.90	
FREQUENCY COUNTER-GENERATOR	194A/B	£12.50	
OCT 89			
EASI-BUILD VOICE-OP-SWITCH	195	£4.90	
HOME SECURITY CONTROLLER	196A/C	£19.50	
DEC 89			
VIDEO AGC STABILISER	199	£6.50	
ECHO STATION	200A/B	£11.50	
MINI METRONOME	201	£4.90	

PE COMPETITION RESULTS

MAPLINOSCOPY!

WE'VE TRACED THE TRIPLE WINNERS!

Maplin AND **PE**

COMBINED FORCES IN THE
SEPT 89 ISSUE TO LET
THREE OF YOU WIN A
SUPERB MAPLIN TRIPLE-
TRACE 20MHZ
OSCILLOSCOPE!

THESE ARE THE LUCKY WINNERS :

Dr Colin G. Owen of Luckington, Wilts.

J.F. Young of Totnes, Devon.

G. Harris of Bromyard, Herefordshire.

CONGRATULATIONS
TO THE THREE OF YOU!

THE ANSWERS!

These are the answers I was after:

1. The initial letters CRT stand for Cathode Ray Tube.
2. The name Rayleigh is renowned for electronic supplies (Maplin have their HQ there of course!)
3. Signal phase and frequency comparison patterns on a scope screen are called Lissajous Figures.
4. In a scope tube the electron beam starts its journey to the screen from the cathode.
5. In the list including oscilloscope, video camera, tv set, radio, computer, cash dispenser, radar, the odd one out was radio.
6. The common link in the list was that all except the radio commonly have a crt or other visual display.

ANALYTICALS

The response to this competition was astonishingly high and it's a shame that you all couldn't win. Owning an oscilloscope gives electronic enthusiasts a tremendous advantage when pursuing their circuit building or testing. We know the winners will really benefit from their good fortune.

It was most unexpected that quite a few of you did not know what the letters CRT stood for. Those who were wrong on this mostly thought the answer was *Cathode Radar Tube* - well fooled, weren't you! A handful thought the answer was *Caesium Ray Tube*. At least I didn't spot anyone answering *Capacitive Resonance Trigger*! But why didn't a lot of you write in the answer as requested? you just circled *Other* and left it at that.

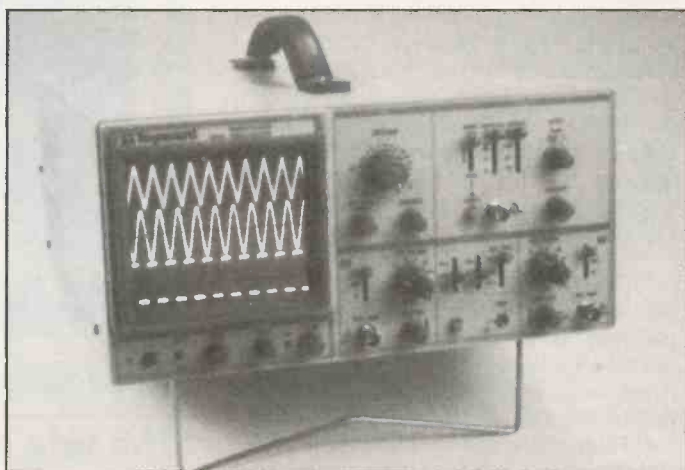

RAYLEIGH

The answers to Q2 were interesting. Most of you spotted that because Maplin were so generously involved in the competition this question was related to them. The commonest wrong answer was *Bicycles*; no, bikes are not manufactured by Rayleigh - the spelling for that is Raleigh. Sir Walter also used the latter spelling, so the answer of *Plymouth Hoe* should have been regarded as a trick one - a few of you fell for it! The answer of *Maplin Sands* was also a trick one - certainly Maplin named themselves after Maplin Sands, but their HQ is not on the Sands (which are tidal and a Ministry of Defence Danger Area!). I was happy to accept either *Electronic Supplies* or a written-in answer relating to Maplin's electronic activities.

But I was also interested by the number of you who knew the name Rayleigh had other historical significance. Baron Rayleigh (1842-1919) was one of the most eminent British physicists; an authority on sound vibrations, and the co-discoverer with Sir William Ramsey of the gas Argon. Several physical terms are named after Rayleigh, but so far as I know he had no connection with the invention of the CRT (as one reader suggested). He was awarded the Nobel Prize for physics in 1904.

Q3 ONWARDS

Nearly all knew that *Lissajous* Figures (or patterns) were Q3's answer. Only one person said *Lissotrichous*, and no one said *Listeria*.

The only wrong answer given to Q4 was *Anode*, and only a small percentage of you quoted it.

Q5 and Q6 proved what versatile imaginations there are among PE readers when it comes to spotting relationships. Most of you actually spotted that *Radio* was the one I was looking for, and that the link was related to crts or some other form of visual display. A good case for *Cash Dispenser* was made by several people, and *Oscilloscope* also had a few well-reasoned supporters. There were too many answers to Q6 for quotation, but two I especially liked: *Computer* was odd because electronics is not essential to its operation (examination of the definition of a computer reveals the truth of this); *Oscilloscope* was odd because only it could be won in this competition!

Well done, the winners; commiserations to the rest of you - better luck next time!

We have still not heard just what has been the result of the supernova in the large cloud of Magellan which made headline news in 1987. Reports of a pulsar have still not been confirmed, and we do have to admit that at the moment the situation is unclear. The supernova itself has faded far below naked-eye visibility, but it can still be seen with large telescopes - provided you are lucky enough to be observing from the southern hemisphere!

Astronomers are still awaiting the launch of the Hubble Space Telescope, which should have been in orbit long ago, but was delayed by the Shuttle disaster. (To refresh your memory, the HST is a 94-inch reflector which will be sent into an orbit 300 miles above the Earth's surface). Now, at last, there is a definite schedule: March 1990. Let us hope there are no further delays.

On the debit side, we have the virtual loss of the astrometric satellite Hipparcos, which was intended to provide the most accurate catalogue of stellar parallaxes and proper motions ever compiled. It was launched by the Ariane rocket in August, but its own propulsion failed - this time, one cannot blame Ariane - and Hipparcos ended up in an orbit which makes it virtually useless. Unfortunately there was no 'back-up'. No doubt another Hipparcos will be built, but there is no denying that this is a grave setback, and one's sympathy goes out to the scientists who have given years of their lives to the project and were looking forward to the final catalogue to be produced in the mid-1990s. The cause of the failure is still obscure; in the end it may have to be put down to 'just one of those things'.

SPACE

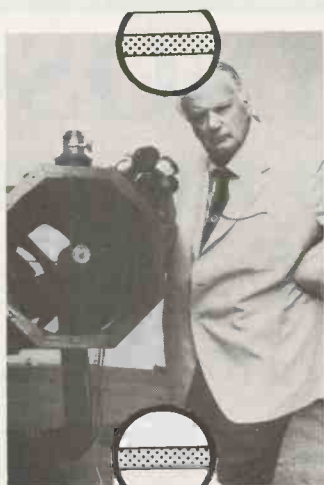

WATCH

BY DR PATRICK MOORE CBE

The fate of Hipparcos is distressing to all concerned, but the success of the Neptune fly-by is a magnificent achievement.

NEPTUNE

Now, weeks after the event, we can start to evaluate the results of the Voyager 2 pass of Neptune on August 25. There is no doubt that it was a major triumph. Remember, Voyager was launched in August 1977, and its design had been completed several years before that. This means that by modern standards it is an ancient vehicle; the technology of the 1970s seems to take us back into a sort of Stone Age. To complicate matters further, Voyager 2's main receiver failed as early as 1978. After a brief recovery it went out action permanently, and ever since then Voyager has been operating on its back-up system, which is in itself faulty. This makes it all the more remarkable that at the Neptune pass, after a journey of more than 4,000 million miles, everything was working even better than at any other time during the mission.

How could this be done? Simply by updating the equipment on Earth - so that the 1970s Voyager was operating with the technology of the late 1980s. It reached its target within six minutes of the predicted time. (British Airways, please copy.) Moreover, it was under full control. As it drew in towards Neptune, six new inner satellites of the planet were discovered; one of these was well over 100 miles in diameter (larger than one of the previously known satellites, Nereid), and it was impossible to adjust Voyager so that a close range picture could be taken of it. The satellite proved to be very dark, and rather irregular in shape, with one large crater. The second of the new

THE NOVEMBER SKY

Several of the planets are on view this month, but Mercury is not among them; it passes through superior conjunction on November 10, and will too close to the Sun to be seen. Venus, however, is a brilliant evening object. It is a long way south of the celestial equator (its declination is around -26°) but by the end of the month it is visible for almost two hours after sunset. It reaches eastern elongation on November 8, and should then theoretically be at half-phase; but during evening elongations dichotomy is always slightly early (Schroter's effect). By the end of the month the phase will be reduced to 36%, and it will be time to start looking out for the elusive Ashen Light; observers with adequate telescopes please note.

Mars is drawing slowly away from the Sun, but the apparent diameter is still below 4 seconds of arc, and at magnitude 1.6 Mars is no brighter than Castor in Gemini. Jupiter, however, is coming up to opposition (which it reaches at the end of December) and since it is well north of the equator it is on view for most of the night. Jupiter has been of unusual interest recently; the South Equatorial Belt, which at the start of the year was the most conspicuous belt on the planet's disk, has virtually disappeared, so that telescopic observers will be very much on the alert. Saturn, the other giant, is still an evening object, but is very low, and sets not long after the Sun. Uranus and Neptune are both fairly near it, but at the moment neither of these can be seen without optical aid.

The Moon is at First Quarter on November 6, full on the 13th, Last Quarter on the 20th, and new on the 28th. Perigee is due on November 12, and apogee on the 25th. There are no solar or lunar eclipses this month, but the Sun is becoming more and more active,

so that we may well have more displays of aurorae - though it is impossible to be sure, and we may have to wait a long time for a display as good as last March.

Comet Brorsen-Metcalf will still be visible. There are also two meteor showers. The Taurids are active throughout the month, but are usually rather sparse. Not so with the Leonids, which reach their peak on the 17th. Occasionally, the Leonids are spectacular, as last happened in 1966, we do not really expect much this year, but we may be fairly sure of another 'storm' in 1998 or 1999, and it is worth keeping watch just in case the Leonids take us by surprise.

Orion now rises at a respectable hour, and will dominate the evening sky all through the winter and into spring; with its two leaders, the red Betelgeuse and the pure white Rigel, it is certainly the most impressive of all the constellations. Following it round, Sirius, the brightest star in the sky, comes into view after midnight. Capella, the yellow star in Auriga, is almost overhead; Ursa Major, the Great Bear, is low in the north, though from Britain it never sets. The so-called 'Summer Triangle' (Vega, Altair and Deneb) is descending in the west, though of these bright stars only Altair is not circumpolar. The Square of Pegasus remains prominent in the southwest; below it is the large, dim constellation of Cetus, the Whale, whose only real claim to fame so far as the naked-eye observer is concerned is the presence of the red variable star Mira.

The W of Cassiopeia is very high up. Its three leading stars (Alpha, Beta and Gamma) are all about magnitude 2, but Gamma is definitely variable, while Alpha may be. Look at them, and see whether you can decide which of the three is the brightest!

satellites was also imaged satisfactorily.

Voyager made a whole series of discoveries during its pass. Neptune does have rings - three of them, though they are very faint, and parts of them are almost beyond the threshold of Voyager's visibility; there is no chance of seeing them directly from Earth. Neptune itself is a dynamic world, very different from the bland Uranus; there is one feature, the Great Dark Spot, which dominates the entire scene. It has been likened to the Great Red Spot on Jupiter, though it is not red (it is merely rather less blue than the rest of the planet). The magnetic field of Neptune is a surprise. It is weaker than those of the other giant planets, and, as with Uranus, the magnetic axis is inclined sharply to the axis of rotation; the angle is around 50 degrees, as against 58 and a half degrees for Uranus. Oddly, then, Neptune seems to be much more like Uranus than either Jupiter or Saturn from a magnetic point of view.

Triton, Neptune's large satellite, was the highlight of the whole mission; its pink and white surface, coated with nitrogen and methane ice, was seen in detail (earlier fears of a cloud-laden atmosphere proved to be unfounded; the Tritonian atmosphere is very tenuous indeed, with a ground pressure of no more than 0.01 millibar). It may also be that beneath the surface, at a depth of no more than a hundred feet or so, there may be a sea of liquid nitrogen; when this nitrogen percolates upward, it 'explodes' and produces



Neptune, featuring the Great Dark Spot. Photo by courtesy of NASA-JPL.

what may be termed an ice volcano (or, more appropriately, an ice geyser). Nothing of the sort had been expected, particularly as Triton, with its temperature of -400 degrees Fahrenheit, is the chilliest place ever visited by a spacecraft.

All in all, I feel that the most remarkable triumph of the mission was the endurance of Voyager 2 itself. Even now it has not completed its task, though Neptune and the other planets have been left far behind. We hope to maintain contact for the next 25 years,

by which time Voyager will have reached the edge of the heliosphere (that part of the Galaxy over which the influence of the Sun is dominant). Until its power fails, it will go on sending back data about the solar wind, interplanetary magnetic fields, cosmic rays and much else. Then, sadly, it will be gone. In just under 300,000 years time it will pass within 4.3 light-years of Sirius; I wonder whether any 'Sirians' will find it and examine the record that it carries, hoping to find out whence? I would like to think so.

PE

Astronomy Now

Britain's leading astronomical magazine



In the November issue:

☆ Space Telescope Readied for Launch ☆ Jeremiah Horrocks and the Transit of Venus ☆ Neptune in Close-up ☆ Meteor Myths ☆ plus: News Update - The Night Sky - Sky Watch Down Under and more...

WIN A MEADE TELESCOPE!

Remember to look out for our December issue competition!

November issue on sale now - price £1.50!

Published by Intra Press - Publishers of Practical Electronics

Six months ago, in the June 89 issue, Robert Penfold described a really sophisticated metronome that would suit the music workshop of any equally-sophisticated musician. But I know that not all of you music fiends need a deluxe machine to knock out the beats in the back bedroom. So for this month's Easibuild project, I've a circuit that's somewhat further down the spectrum in deluxification, but which offers you a broad selection of beat markings and rates.

FUNCTIONS

Not only does the unit have an audio output, it has a red/green led visual display as well. You can 'program' it for accenting one beat in two, or one beat in three, and so on up to one beat in ten, plus constant running without any accent at all. The basic rate is controllable from the panel between about 20 and 200 beats per minute, though you can change the range at the time of setting-up if you prefer.

In keeping with the nature of this series, I've made the circuit quite simple, using just two ic's: a quad opamp, and a decade counter.

CLOCKING

The first of the opamp sections is shown in Fig.1 as IC1a. This forms the master clock oscillator, and is of a type which I have described in other Easibuild projects, for

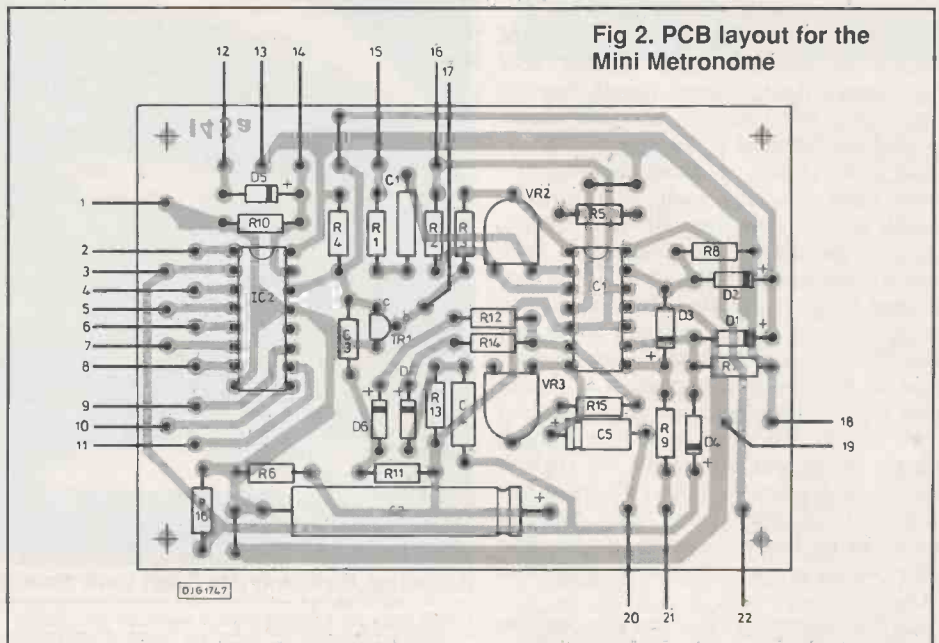

Fig 2. PCB layout for the Mini Metronome

Whatever the closing time you can count the bars with John Becker's flashy simple super sonic metre beater.

example in the *Wheezy-Jeeby Sirens* of June 89. The oscillation rate is set by C1, VR2 and the total resistance of VR1 plus R1. VR2 set the basic range, and VR1 then controls it from the panel.

The 324 opamp used does not reliably swing cleanly between the levels required to drive the decade counter chip, and so TR1 has been included to ensure the maximum swing. Also connected to TR1 is S1a which allows you to

MINI METRONOME

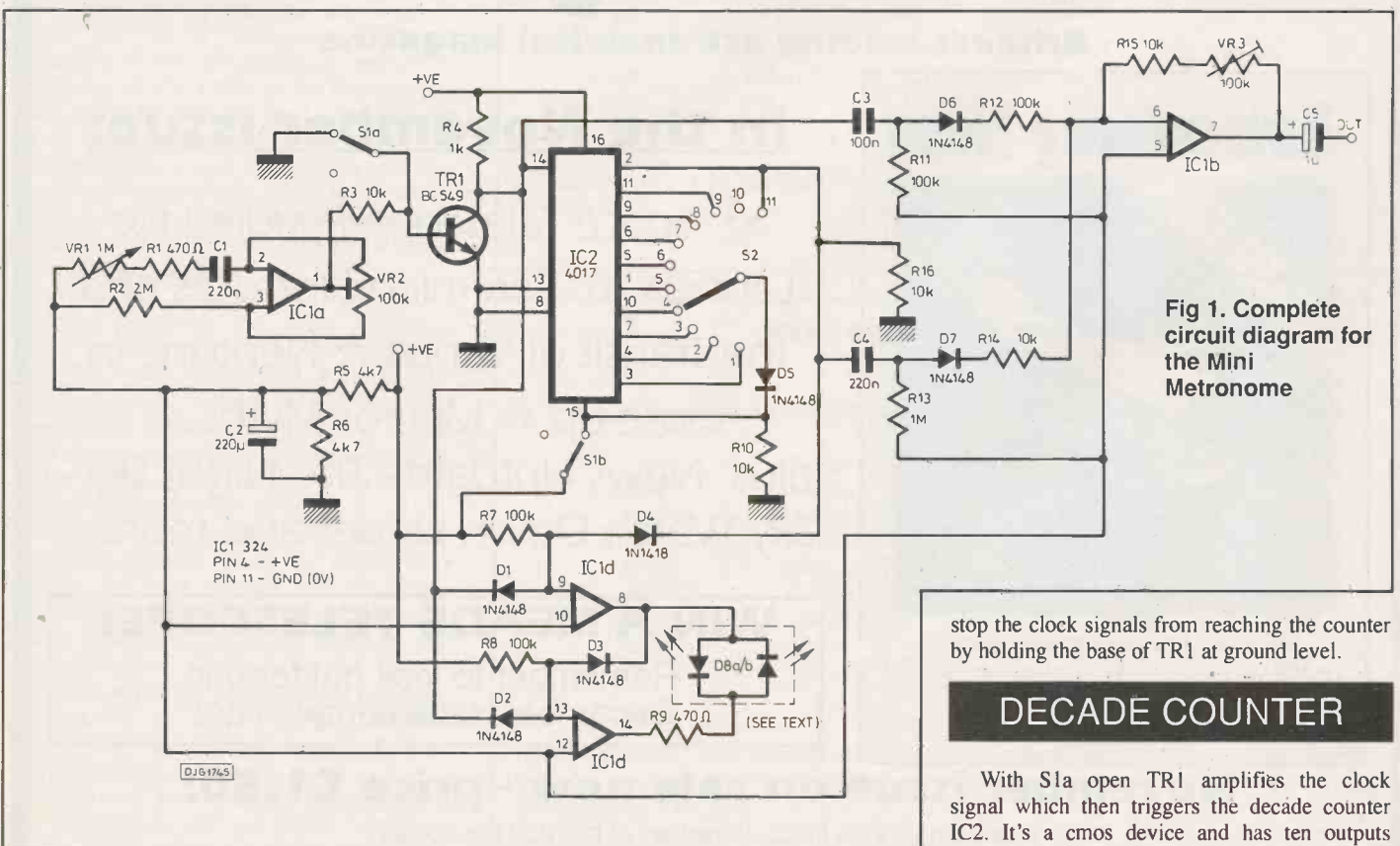

Fig 1. Complete circuit diagram for the Mini Metronome

stop the clock signals from reaching the counter by holding the base of TR1 at ground level.

DECADE COUNTER

With S1a open TR1 amplifies the clock signal which then triggers the decade counter IC2. It's a cmos device and has ten outputs



which normally are consecutively triggered high once every ten clock pulses. As one output goes high, so the preceding one goes low. The ic has a reset input too, of course, and so the cycle of ten can be shortened by selecting any of the outputs to trigger the reset on whichever division beat you wish.

CLICK ROUTE

You will see that the signal from TR1 also is routed to the circuit around IC1b. The pulses are shaped by C3 and R11 and their spikiness is dictated by the value of both components. The spiky pulse is amplified by IC1b and can be fed to any normal amplifier and speaker system, from which they will be heard as clicks. The sound of the click will depend on how spiky it is. The clicks coming along the C3 route are those for the 'tick' sound. The 'tock' sound comes from the counter route.

S2 selects which output you want to use as the reset pulse fed back via D3. Each time IC2 is

COMPONENTS

RESISTORS

R1, R9	470 ohms (2 off)
R2	2M or 2M2
R3, R10, R14-R16	10k (5 off)
R4	1k
R5, R6	4k7
R7, R8, R11, R12	100k (4 off)
R13	1M

All 0.25W 5% carbon film.

CAPACITORS

C1, C4	220n polyester (2 off)
C2	220µF 16V elect
C3	100n polyester
C5	1µF 16V elect

SEMICONDUCTORS

D1-D7	1N4148 (7 off)
D8	red-green led (see text)
TR1	BC549
IC1	324
IC2	4017

POTENTIOMETERS

VR1	1M lin rotary
VR2, VR3	100k skeleton preset (2 off)

SWITCHES

S1	min dpst toggle
S2	1p12w rotary
S3	min spst toggle

MISCELLANEOUS

PP3 battery clip, pcb supports (4 off), 14-pin dil ic socket, 16-pin dil ic socket, mono jack socket, knobs (2 off), printed circuit board, box to suit, solder and wire.

Fig 3. Wiring details

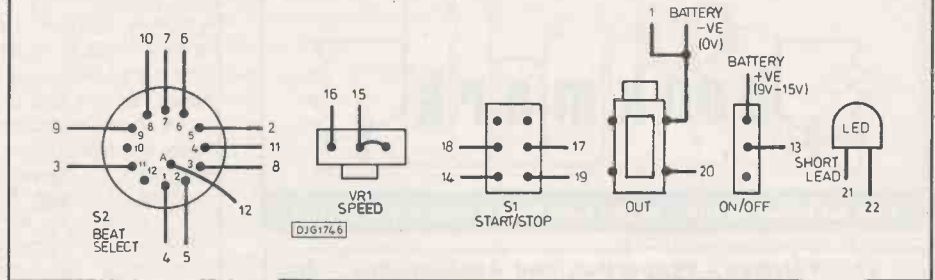

reset, its '0' output goes high, and generates a pulse across C4 and R13. Since C4 has a greater value than C3, a heavier pulse will be amplified by IC1b.

FLASHY BITS

Now for the flashy bit! I've used IC1c and IC1d as a special gating circuit driving a bi-colour led. Depending on the polarity of the voltage across it, the led will show red, or green, or nothing at all. The polarity across the led depends on the output states of IC1c/d. These are conditioned by the logic states of their inputs as controlled by R7, D1, D2 and D3. There are four output combinations: both outputs high, both low, and either output high with the other low. In the first two states neither part of the led will be active, but in the latter two states the relevant colour will glow, depending on the polarity. Because of the action of D3, the output from IC2 pin 2 will override the output of TR1, thus each normal beat will show as one colour, with the accented beat shown by the other. Between each beat neither led will glow.

DIODE GATING

The action is as follows: Basically, both opamps are connected as comparators with the reference level set by the voltage at R5/R6. Ignoring the action of D3 and D4 for the moment, when the collector of TR1 is low so too will be the inverting inputs of IC1c/d, via D1 and D2, consequently both outputs will be high and the leds don't glow. When TR1 collector is high, D1 and D2 block the positive voltage from reaching the opamps. Instead they are biased by the positive voltage through R7 and R8, and thus both outputs are low and the leds still don't glow.

However, when the '0' output of IC2 (pin 2) is low, as it will be for each unaccented beat, the inverting input of IC1c will also be held low via D4, and that opamp output will be high. When the collector of TR1 is also high the output of IC1d will be low, therefore current will flow from IC1c to IC1d via the respective conducting led, which will then glow. When IC2 pin 2 is high, on the accented beat, and TR1's collector is also high, the output of IC1c will go low, pulling down the inverting input of IC1d via D3. Thus the output of IC1d will be forced low, and the current will flow in the opposite direction, through the other led.

When S1 is switched off, not only will TR1 cease to conduct, but the counter will automatically be reset to zero by S1b, ensuring that the beat pattern always starts from the same point.

The unit is intended for powering by a 9V battery, such as a PP3 or PP9, though it may also be powered by any voltage up to 15Vdc.

CONSTRUCTION

The main points to observe in construction are the correct polarity of all the semiconductors, though the led may be inserted either way round, depending on which colours you want to mark the beats. You may alternatively use two separate leds of different colours, inserted in opposite directions.

With the switch S2, the locating washer under the crimped washer should be adjusted so that only eleven positions can be selected. In positions 1 and 11 no accent will be seen or heard - each beat will be the same.

Initially, set VR2 midway then, once you know the circuit is functioning, readjust it until VR1 varies the rate within the range required.

The audio output should be taken to the line input of an ordinary home amplifier. VR3 should first be set at minimum resistance (least gain through IC1b), and if necessary then increased to provide greater pulse amplification. However, do not increase VR3 too much otherwise the beat emphasis could be lost. The settings of the amplifier tone controls could also affect the audible difference between the marked and unmarked beats.

PE

Fig 4. Pcb track layout

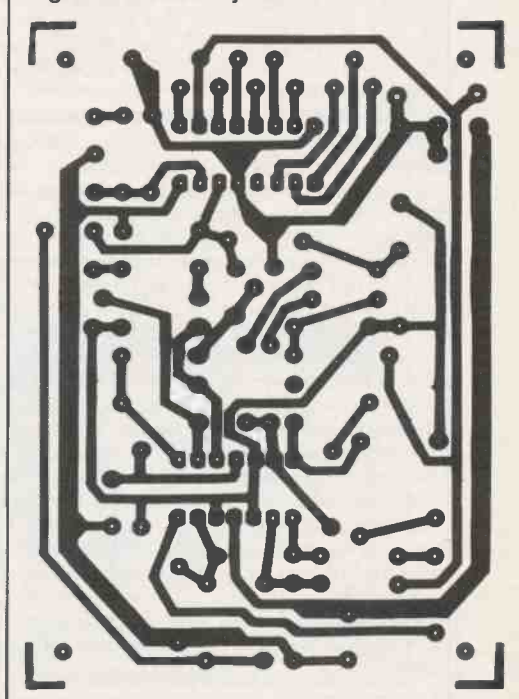

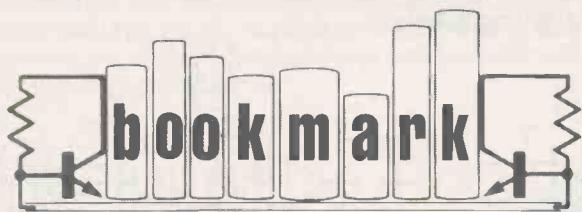

Your Ed looks at some of the new books recently received.

Soft Ferrites - Properties and Applications - 2nd Edition. E.C. Snelling. Butterworths. £60. ISBN 0-408-02760-6. Very much a book for the advanced constructor/designer. It is concerned with the technically important properties of magnetically soft ferrites at frequencies up to about 100MHz, and the application of these ferrites to inductors, transformers and related devices. It is primarily intended for electronic engineers and physicists whose work involves design or development using these ferrites. The first four chapters deal with the properties of ferrites and magnetic materials in general. The next six chapters deal with a basic type of ferrite cored device, including inductors, high frequency transducers, transformers and antennas. The final chapter examines the properties of windings and is followed by four appendices covering calculations, wire tables, publications and symbols. A comprehensive list of references and bibliography follows each chapter. Undoubtedly a highly informative book which has been thoroughly updated since the first edition of 1969.

Audio IC Circuits Manual. R.M. Marston.

Heinemann Newnes. £10.95. ISBN 0-434-91210-7. I am sure that anyone who is interested in designing and building audio circuits will find this book to be an extremely useful addition to the workshop library. It's full of circuit building blocks for audio processing, preamps, power amps, high-power amps, led bargraph displays, ccd delay-lines and power supplies. A reasonable selection of ic types is quoted, most of them readily available, and although I know that a couple of chips listed are obsolete, having been deleted by the manufacturer (TDA1022 and TDA1097), circuits using alternative chips are given. I would also liked to have seen more formulae given - not of the higher maths type, but of the more usual common-or-garden variety. Unless basic formulae are contained in a book of this nature, the adventurous constructor can be at a loss for information on how to modify the circuits shown to cater for different parameters - the filters section is one such area that would have benefited. Nonetheless, I am pleased to recommend this book to average-capability readers.

The Digital IC Handbook. Michael S. Morley. Tab Books £39.30. ISBN 0-8306-9302-5. "Fast, accurate information guaranteed to simplify your search for the right digital ic", is the claim made on the cover of this book. No, Tab, I cannot accept that this statement will be true for the majority of electronics designers in Britain. I acknowledge that some of the text material on the nature of general logic families may be of use to those whose understanding of electronics is still rudimentary. But the rest of the information, taking up most of the pages, seems almost totally irrelevant to beginners or experienced designers. The bulk of the pages principally consist of lists and more lists of device numbers, brief descriptions of their functions, a few parameters, and the price in US dollars. As one who spends much of his time designing, I believe that I would find little practical benefit from the data. There should at least be the pin-out configurations shown, and what use is the dollar price to those who buy products in Britain? I find that there is usually no substitute for the data books produced by chip manufacturers, and these books are readily available and not too expensive. Most manufacturers will be only too happy to sell (and sometimes to give away free) their data books to seriously interested designers. Distributors such as RS Components and Electromail also sell a good selection of data books. (If any PE advertisers also sell them, publicise the fact by telling me.) I would far sooner have readers buy slightly outdated *real* data books than spend £39.30 on a book that looks impressive but which is far too short on useful content.

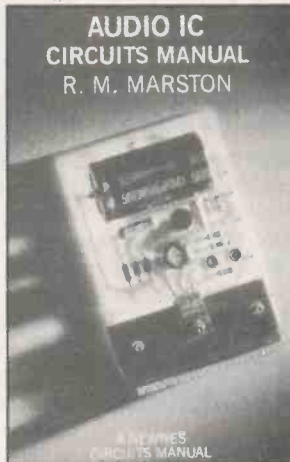

Computers and Music.

R.A.Penfold. PC Publishing. £7.95. ISBN 1-870775-07-4. Robert Penfold is, of course, one of PE's well respected authors. As usual, he's in top form with this book that should interest anyone who wants to know more about computer controlled music making. Although I felt wary of the statement on the back of the book that 'No previous computer knowledge is needed', many people may well find the statement to be true, for Robert gives a thorough covering of the basics of computing, devoting four chapters and over 80 pages to the subject. In those pages he starts right back at the computer keyboard, progresses through rams and eproms, discusses ports and peripherals, and takes a look at actual computers. Among them, he comments on the Commodore 64/128, BBC Master, Amstrad CPCs, Spectrum, Atari ST, Amiga, Yamaha C1, and IBM PCs and compatibles. The remaining three chapters then discuss specifics about Midi, music software, and Midi instruments. Finally, three glossaries define terms, give hexadecimal numbers, and offer shopping advice on printers, computers, synthesisers and samplers, and software. An extremely useful book.

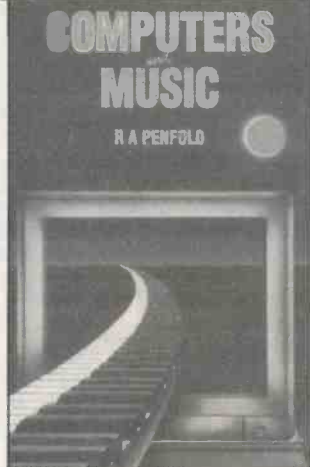

Practical Electronics for GCSE.

Owen Bishop. John Murray (Publishers) Ltd. £6.95. ISBN 0-7195-4632-X. As well as being a frequent and highly respected contributor to PE, Owen is the author of very many books. I am delighted by the way in which he is presenting the information in his latest book. There is a similarity in style and illustrative presentation that will be familiar to those who have been following Owen's recent Digital Electronics series for PE. Many of the simpler instructional circuit assemblies are designed for use with plug-in breadboards, though Veroboard is also used for some of them. The publishers claim that the book offers the most comprehensive course of fully documented electronics practicals yet made available at this level. I can well believe it, and Owen makes the subject *interesting*. The book is split in to five parts: Electronics Workspace, Practicals, Modules, Electronic Systems, Data. The first section looks at components and tools, power supplies, measuring, and construction, with a selection of useful photographs tracing the assembly of a project. The Practical section starts off looking at electric current, following on with aspects such as resistance, capacitance, inductance, and then through diodes, transistors, logic gates, memories, amplifiers, and filters. Under Modules come various subjects, including input, process, and output modules. Part four has a selection of useful and practical circuits to build, and part five is a short appendix giving a few ic and transistor connections and design data, concluding with a summary of the symbols used in the book. This is undoubtedly a very thoroughly thought out book and will be of immense value to anyone in the early stages of learning about electronics, even if they are not doing GCSE.

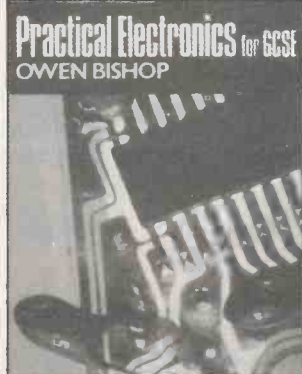

Build Your Own 80386 IBM Compatible and Save a Bundle.

Aubrey Pilgrim. Tab Books. £13.20. ISBN 0-8306-3131-3. If you live in America you probably could 'save a bundle', but otherwise it could cost you a packet trying to obtain the parts from the US suppliers quoted. In any case, the assembly procedure only takes up a small part of the book, and the relevant illustrations appear mainly concerned with showing you how to insert plugs into sockets. The remainder of the book is largely concerned with descriptions of various peripheral devices, backup systems and troubleshooting tips, the latter basically of the commonsense variety "if it breaks down try not to panic...if you can't solve the problem, call your vendor for help".



Designing with Linear ICs. G.C.Loveday. Benchmark Book Company. £8.75. ISBN 1-87104702-1. One aspect of this book immediately takes my interest, that it realistically discusses the use of proprietary cad software for analysis of opamp circuit responses. The book is aimed at the serious user of linear ics but will also be of interest to those who have only rudimentary knowledge and wish to know more. Some of the sections require an understanding of mathematics, but not at a particularly high level. There are numerous illustrative examples of practical circuits, mainly associated with opamps, though a whole chapter is devoted to timer ics. The fifth chapter sets some worked design problems, dealing with the concepts, procedures and rules of thumb required in analogue design. Solutions to the problems are given in the final chapter. This appears to be an invaluable book to have on one's bookshelf or workbench. It's also apparent that Mr Loveday should be sharing his knowledge with electronic hobbyists through PE's pages -I'll be looking into it!

Laser Experimenter's Handbook - 2nd Edition.

Delton T. Horn. Tab Books. 11.10. ISBN 0-8306-3115-1. First, A **WARNING** - lasers can be dangerous and the projects within this book are not for inexperienced constructors. The book gives background information on the theory and history of lasers while offering a number of practical, simple experiments that use relatively low power and present minimum risks. Those projects include a simulated laser, an infrared detector, a continuous wave solid state laser, and modulated laser beam transmitter and receiver. Although I



warn about the potential danger of the projects, the overall information given in this book will be of interest to those who wish to know more about lasers in theory and in practice. For those who are experienced and responsible constructors, the five projects should make interesting experimental circuits. Note, though, that the constructional information is fairly minimal and that you will probably need to purchase some of the components direct from the American suppliers quoted. Within the constraints of my warning, this book is worth reading.

The Laser Cookbook - 88 Practical Projects. Gordon McComb. Tab Books. 14.25. ISBN 0-8306-9390-4. I spent some time considering whether or not I should give publicity to this book - some of the projects are potentially extremely dangerous. I am also horrified by the humorous(?) phrase in the introduction about "playing 'laser-tag' with the cat". Lasers are too dangerous to be used in any situation that is not under very close control they can blind, and some of the power supply voltages can be lethal. However, there is much information in this book which will be of interest to experienced and responsible constructors and it is for their benefit that I have decided not to 'censor' the book. It has over 400 pages, and contains 24 chapters, several of which are concerned with laser theory, safety procedures, required tools and where to obtain parts. Among the topics, the book shows how lasers can be used in holography, optics and optical experiments, laser guns, laser light shows, laser beam intrusion and detection systems, aerodynamics and airflow study, coherent light seismology, laser beam communication, laser and fibreoptics computer data links, and precision measurement. There is no doubt that this is an interesting book, but if you buy it, **DO TAKE CARE.**

Computer Hobbyists Handbook. R.A. & J.W. Penfold. Babani. 5.95. ISBN 0-85934-196-8. Robert (of PE fame) has combined with his brother to produce this large format 120 page handbook. The Penfolds say in their preface: "The aim of this book is to provide a useful range of data and general information on a variety of computer topics, including such things as interfaces, computer languages, Midi, and numbering systems. There is also a useful lexicon of computer terms, and some helpful appendices. This book is not intended to be a course in computing, but does provide a useful reference for data and information in a single source where it can be quickly and easily found. It does not simply supply raw data, but where necessary detailed explanations are also included. It should be equally useful to both beginners and more experienced hobbyists." Yes, I think I can go along with that so far as brief examination of the book shows. It certainly appears to be a book to which one would turn for subject definitions. However, doing a check on a few items of relevance to one of my computers, an Amstrad 1640, I was forced to conclude that my user handbooks would still be needed. Probably the book will be of greater value to an early starter than to one who has been involved with computing for many years.

The Handbook of Microcomputer Interfacing - Second Edition. Steve Leibson.

Tab Books. 15.60. ISBN 0-8306-3101-1. This is good healthy volume of over 300 pages which is basically about how to get information into and out of computers. In other words, it's about interfacing. Its nine chapters cover Bits Bytes and Buses, Component-Level Busses, Backplane Busses, Parallel Interfacing, Serial Interfacing, Interfacing to Analog Devices, Time, Interrupts, and Direct Memory Access Interfacing. Three appendices cover a number base

THE HANDBOOK OF MICROCOMPUTER INTERFACING
Second Edition

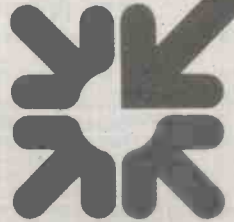

calculator program, integrate chips, and ic manufacturers. The book concludes with a parts list and index. The information presented will be of interest to any reader (whichever side of the Atlantic they live!) who is after a good introduction to computer hardware and I am pleased to recommend it.

Encyclopaedia of Electronic Circuits - Volume One.

Rudolf F. Graf. Tab Books. 28.15. ISBN 0-8306-1938-0. I said of Volume Two when I reviewed it a few months ago that I wished I had Volume One as well. Now I have, thanks to the helpfulness of Karen Brown at John Wiley and Sons, the importers. This is as much a book for every enthusiast as its companion. It has over 750 pages and shows nearly 1300 circuits! The circuits are arranged in alphabetic subject order within 98 basic circuit categories. There is an extremely thorough master index, and an unusual index as well - this quotes the original source of the circuits, ie manufacturer's data sheet, electronics magazine etc, and will be of use should additional information be required. I am pleased to possess both volumes of this encyclopaedia, and thoroughly recommend either or both of them to any electronics experimenter. The price is certainly not high for the quantity of information offered. This is sort of book at which Tab excel, and deserves to be on the workbench.

The Complete Electronics Career Guide. Joe Risse. Tab Books. 12.60. ISBN 0-8306-3110-0. There is no in which I can say that this book is suitable for the UK market. It cannot possibly be relevant when all the information regarding companies and qualifications is oriented to the American market. There might be the occasional paragraphs that cross the Atlantic successfully, but they will be few and far between. It seems highly irresponsible for Tab to introduce this book to the UK.

How to Draw Schematics and Design Circuit Boards with Your IBM-PC. Steve Sokolowski. Tab Books. 11.10. ISBN 0-8306-9334-3.

This certainly appears to be a useful book from Tab, and is applicable to IBM-PCs or compatibles. Purchasers of the book can order the software on disk using a reply card supplied with the book, or they can key it in from the lengthy Basic listings published. The author shows how you can draw lines, circles and schematic symbols with your PC using the directional arrow on the keyboard. There are four chapters in this nearly-200 page book. The first one covers the Schematic Designer program, looking at how graphics are displayed, how they can be drawn and new symbols added, and a practical circuit drawing is illustrated, for a power supply. Chapter two gives the pcb designing program, discussing various aspects of it, and discussing how to modify the program. CAE program screen displays are discussed in chapter three. Chapter four is a series of appendices, covering such items as the hierarchy of cae reserve words, a summary of cae commands, making backup copies, and a glossary of terms.

PUBLISHERS' ADDRESSES

Bernard Babani (Publishing) Ltd, The Grampians, Shepherds Bush Road, London W6 7NF. 01-603 2581.

Benchmark Book Company, 18 Regency Close, Uckfield, E. Sussex TN22 1DS.

Butterworth Scientific Ltd., Westbury House, Bury Street, Guildford GU2 5BH.

John Murray (Publishers) Ltd., 50 Albermarle Street, London W1X 4BD.

Heinemann-Newnes, 22 Bedford Square, London WC1B 3HH. 01-637 3311.

PC Publishing, 4 Brook Street, Tonbridge, Kent TN9 2PJ.

Tab Books are imported by **John Wiley and Sons Ltd**, Baffins Lane, Chichester, W. Sussex, PO19 1UD. 0243 779777.

APPOINTMENTS



An important message for Communications Technicians

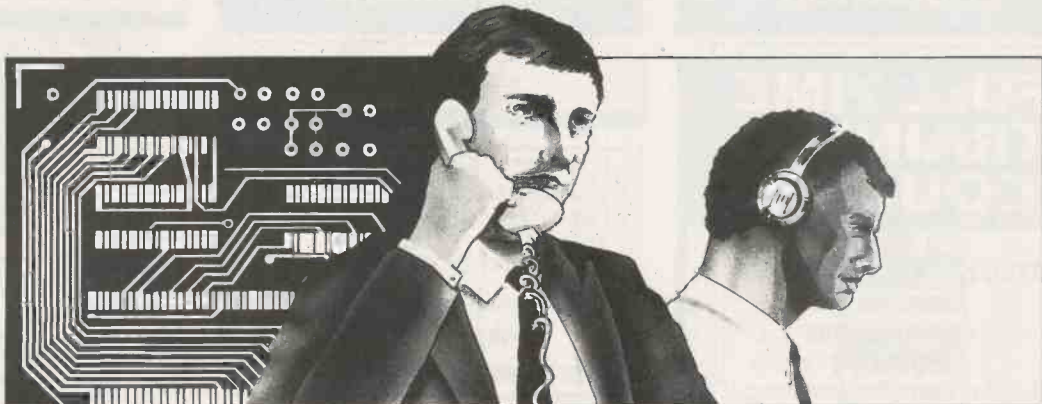

Advanced electronics is playing an increasingly major role in the development of London Underground. As we modernise our stations, offices and railway sites, we can now offer more scope and opportunities for Communications Technicians than ever before—installing closed circuit television and on-train radio, public address systems, telephone and data networks.

You will work a basic 38-hour week at a weekly rate of £212 but, with the opportunities for overtime and night work, can expect to earn around £286. You will also enjoy free travel on the Underground and most London Buses—plus 75% discount on British Rail for you and your family. Benefits include 25 days holiday

a year—and genuine prospects for promotion.

If you have had technical training, in any two of the specialist disciplines mentioned above, and hold a recognised qualification, this could be your opportunity to get ahead fast in our modern, forward-looking organisation.

For further information and an application form, please fill in the coupon, quoting Ref. CT3 and post it to: Miss Ashley Sezgin, London Underground Limited, Signal & Electrical Engineering (Contractors) Unit, 3rd floor, Griffith House, 280 Old Marylebone Road, London NW1 5RJ.

We are an equal opportunities employer.

COMMUNICATIONS TECHNICIANS

Please send me an application form for the post of Communication Technician:

NAME _____

ADDRESS _____

_____ POSTCODE _____

CT3

PRACTICAL ELECTRONICS CLASSIFIED

Reach thousands of serious electronic and computer enthusiasts. Advertise in PE Classified pages: Rates 20p per word or £8.50 per single column cm (plus VAT). All classified advertisements must be pre-paid. Send your copy with the remittance (payable to Intra Press or payment by Visa or Access accepted) to: Practical Electronics, Intra House, 193 Uxbridge Road, London W12 9RA. Tel: 01-743 8888. Fax: 01-743-3062
LET PE WORK FOR YOU!

EDUCATION

FULL-TIME TRAINING COURSES

2 YEAR BTEC NATIONAL DIPLOMA

Electronics and Communications Engineering

(TV, Computers, Programming, IT)

1 YEAR

BTEC NATIONAL CERTIFICATE

1. Electronic Equipment Servicing

(TV, Video, CCTV)

2. Computing Technology

(Microprocessors, DataComms, Interfacing)

3. Information Technology

(Telecomms, Satellite TV, Networks)

4. Software Engineering

(Assembler, BASIC, Pascal, CAD/CAM)

★ Those eligible can apply for E.T. grant support ★

★ An equal opportunities programme ★

COURSES COMMENCE

Monday 8th Jan. 1990

LONDON ELECTRONICS COLLEGE

Dep: AA, 20 Penywern Road, London SW5 9SU. Tel: 01-373 8721

Start training now for the following courses.

- Telecomms Tech C&G 271
- Radio Amateur Licence C&G
- Microprocessor
- Introduction to Television

Send for our brochure - without obligation or telephone us on 06267 79398 (Ref: PE12/89)
 Name.....

Radio & Telecommunications Correspondence School, 12 Moor View Drive, Teignmouth, Devon TQ14 9UN

RETAILERS

BATH

L.F. HANNEY

77 Lower Bristol Road, Bath, Avon.
 Tel: 0225-24811

Your electronics component specialist for

AVON, WILTS. & SOMERSET

Open every day, except on Thursday

EDINBURGH

OMNI ELECTRONICS

stock a wide range of electronic components at

174 Dalkeith Road
 Edinburgh EH16 5DX

Tel: 031 667 2611

Open Mon-Fri 9am-6pm

Sat. 9am-5am

Send 2x20p stamps for CURRENT CATALOGUE!

HERTFORDSHIRE

Cirkit

Please see our display advertisement in this issue for more details.

Help PE Readers!

Project your component image here!
 Phone PE on 01-743-8888

LONDON EAST

AGE A & G ELECTRONICS LTD.

ELECTRONIC COMPONENTS MAIL ORDER COMPANY.

Electronic components, I.C.'s, diodes, LED's, capacitors, potentiometers, solar chargers, computer disks, video tapes, aerosols, etc.

Brand new quality components at unbeatable prices.

1990 catalogue is out now

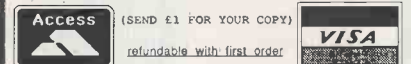

100 Park Avenue, London E6 2SR. Tel: 01-552 2386

MANCHESTER

DEANSGATE ELECTRONICS

We stock a large range of electronic components, test equipment, telephone accessories, computer accessories, microphones, speakers, disc lighting, mixers, meters, stylus, so call in and have a look around.

263 Deansgate, Manchester
 Telephone: 061-834 1185

SOUTHSEA

ELECTRONIC COMPONENTS

EVERYTHING FOR YOUR NEXT PROJECT
 THE BIGGEST DISPLAY IN THE SOUTH IS AT

FRASER ELECTRONICS

42 ELM GROVE ★ SOUTHSEA ★ HANTS
 Telephone: 0705-815584

Barclaycard

Access

STAFFORDSHIRE

MAGENTA ELECTRONICS Ltd

Shop now open
 callers welcome

135 Hunter Street,
 Burton-on-Trent
 Staffs, DE14 2ST

Resistors 1/4 W 5% carbon (E12) 1p metal film 1%3p
 Resistor Pack 85 different E12 values + zero ohm link total content£8.95
 1000 resistors£8.95
 LEDs red/green 3/5mm6p each. Yellow 11p
 Cable ties 7.5mm1p each £5.95/1,000 £49.50 per 10,000
 Stepping motor 4 phase 12v 7.5 step 50 ohms£8.95
 SAA 1027 stepping motor driver chip£3.95
 FM transmitter Kit good quality sound£7.94
 High quality photo resist copper clad epoxy glass boards
 Dimensions single sided double sided
 3x4 inches £0.95 £1.07
 4x8 inches £2.40 £2.68
 6x12 inches £5.37
 12x12 inches £10.66

Special Offers
 Computer Grade Capacitors with screw terminals 38000uf 20v £2.50
 8700uf 10v £1.95, 68000uf 15v £2.95, 10000uf 16v £1.50
 7 segment Common anode led display 12mm£0.45
 LM2931A T5.0 Low drop out 5V regulator T0220 package£0.85
 BS250 P-channel MOSFET £0.45, BC559 transistor£3.95 per 100
 74LS05 hex inverter £10.00 per 100, used 8748 Microcontroller £3.50
 Stereo LW/MW/FM Tuner pre-amp assembly complete with
 volume/tone controls and tuning scale Brand new in makers carton
 £5.95, faulty £2.50
 Circuit diagram description and setting up procedure for tuner
 assembly described above £0.50. 5 digit 6v electromagnetic counter
 £1.95
 Hour counter (used) 7 digit mains 240V AC 50Hz£0.95
 LCD display 16 digit 7x5 dots dot matrix£2.50
 Querty keyboard 58 key good quality switches£5.00
 95p for P&P per order (VAT inc.)
 wide range of CMOS TTL 74HC 74F Linear transistors kits
 capacitors, resistors tools etc always in stock
 JPG Electronics 276 Chatsworth Road Chesterfield S40 2BH
 Access orders (0246) 211202. Callers welcome

**IS YOUR
 CLASSIFIED AD
 A TIGHT SQUEEZE?**

**STRETCH
 OUT**

**in the display pages
 of PE! Phone RICHARD
 CAPLIS on
 01-743-8888 for details!**

Cooke International
 DO YOU WANT
 SCOPES, GENERATORS, POWER
 SUPPLIES, POWER METERS, DVM'S,
 OSCILLATORS, ATTENUATORS,
 TEST EQUIPMENT.

Contact: Cooke International, Unit Four,
 Fordingbridge Site, Main Road, Barnham,
 Bognor Regis, West Sussex PO22 0EB.
 Tel: 0243 545111, Fax: 0243 542457
 Wide range of items available. Send for lists.

PROGRAM NOW
**The Professional Software
 Developers Journal**
 Available from all good
 newsagents -price £1.50
 From The publishers of Practical
 Electronics

Carbon Film Resistors 1/4W E24 series 0.51R to 10MΩ - 1p
 100 off per value - 75p 1000 off in even hundreds per value - £7
 Metal Film 1/4W 10R to 1MΩ 5% E12 series - 2p 1% E24 series - 3p
 1/2Watt metal/carbon film E24 series 1R0 to 10MΩ - 1½p
 1 Watt metal/carbon film E12 series 1R0 to 10MΩ - 5p
 BC107/8/9 - 12p BC547/8/9 - 8p BC182L 184L - 10p
 BFY50/51/52 - 20p 2N3055 - 50p TIP31A, 32A - 25p TIP41, 42, - 40p

Tantalum head subminiature electrolytics (Mids/Volts)
 0.1/35, 0.2/25, 0.4/35, 3.3/16, 4.7/16 - 14p 4.7/35 - 15p
 2.2/35, 4.7/25, 10/5 - 15p 4.7/35, 6.8/16 - 16p 10/16, 22/6 - 20p
 22/16 - 30p 33/10 - 30p 47/10 - 35p 100/6 - 40p

Aluminium Electrolytics (Mids/Volts)
 1/50, 2.2/50, 4.7/25, 4.7/50, 10/16, 10/25, 10/50 - 5p 22/16, 22/25 - 6p
 22/50, 47/16, 47/25, 47/50 - 6p 100/16, 100/25 - 7p 100/50 - 12p
 100/100 - 14p 220/16 - 8p 220/25, 220/50 - 10p 470/16, 470/25 - 11p
 1000/25 - 18p 1000/35, 220/25 - 22p 4700/25 - 70p

Miniature Polyester Capacitors 250V Wkg. Vertical Mounting
 01, 015, 022, 033, 047, 068 - 4p 0.1 - 5p 0.15, 22 - 6p 0.47 - 8p

Mylar Capacitors 100V Wkg. Vertical Mounting E12 Series
 1000p to 8200p - 3p 0.1 to 0.68 - 4p 0.1 - 5p 0.15, 0.22 - 6p

Subminiature Ceramic Plate 100V Wkg. E12 Series Vertical Mounting
 2kΩ 1P8 to 47P - 3p 56P to 330P - 4p 10% 390P to 4700P - 4p
 Ceramic plate/disc E6 Series 50V 22P to 0.47 - 2p

Polystyrene Capacitors 63V Wkg. E12 Series Axial Mounting
 10P to 820P - 3p 1000P to 10,000 - 4p 12,000P - 5p
 1N4148 - 2p 1N4002 - 4p 1N5404 - 14p W01 bridge - 25p
 OA91 - 6p AA143 - 8p W005 - 20p 1N4006 - 6p
 Zener diodes E24 series 3V3 to 33V 400mW - 8p 1 watt - 12p
 L.E.D.'s Red, Green & Yellow 3mm & 5mm - 10p 8mm - 35p
 20mm fuse 0.1A to 5A quick blow - 5p Anti Surge - 8p
 High Speed drills 0.8mm, 1.0mm, 1.3mm, 1.5mm, 2mm - 30p
 Expo Reilant drilling machines 12V d.c. with improved 3 jaw chuck 6.50
 Nicads AA - 80p HP11 - £2 PP3 - £4.20 Universal Chargers - £6.50
 Glass reed switches single pole make contacts - 8p Magnets - 12p

VAT inclusive. Return postage 25p (free over £5). Lists free.

THE C.R. SUPPLY CO.,
 127 Chesterfield Road,
 Sheffield S8 0RN. Tel. 557771.

CAMBRIDGE COMPUTER SCIENCE LTD

10MByte Winchester, used, 3 months Wty, £42.00 each
 5.25" Disk Drives, 80 Track DSDD £34.00 each
 5.25" Disk Drives, 80Tk, DSDD Used, No Wty £15.00 each
 5.25" Disks, DSDD, 48tpi boxes of 10 £3.00/box
 50W PSU 5V 6A, 12V 2.5A, -5V 0.5A, -12V 0.5A £16.00 each
 Gould PSU 0-30V @5A Limited quantity only at £45.00 each
 Single Data lead (BBC Micro to Disk Drives) £2.00 each
 Dual Data lead (BBC Micro to 2 Disk Drives) £ 4.00 each
 Power lead (BBC Micro to Disk Drive) £2.00 each
 Dual leads (BBC Micro to 2 Disk Drives) £ 4.00 each
 68000 CPUs (The first orders get 10MHz chips) £3.50 each
 74LS TTL, pick and mix, buy 10 or more for £0.12 each

Types available: '00 '02 '04 '08 '11 '13 '15 '20 '21 '26 '27 '30
 '32 '38 '42 '75 '83 '96 '107 '109 '122 '132 '136 '139 '145 '151
 '153 '157 '158 '163 '164 '166 '191 '193 '298 '365 '670

EPROMS 27128 used £1.50 each; new 27128-25 £2.50 each
 6264 8K Byte SRAM -15 £3.00 each -12 £3.80 each
 65256 32K Byte rams £7.00 each
 8K Byte NV ram chips £3.00 each £10.00 four
 20 pin dil low profile IC sockets £0.50 (ten) - £ 4.00 (100)
 40 pin dil low profile IC sockets £0.60 (ten) - £ 5.00 (100)
 Keyboard, 100 keys on board LCD & micro iif £8.00 each
 Toroidal mains transformer 12V 4A & 0.4A, 12-0-12 @0.1A & 2A,
 9-0-9 @0.2A £4.00 each -£6.00 for 2. -£8.00 for 3

Prices include postage. Add 50p to orders below £5.00. All items
 new unless stated. Add 15% VAT to all prices. Send an SAE for our
 latest list or for more info. **Dept PE, 374 Milton Road,
 Cambridge, CB4 1SU Tel: 0223 424602**

74HC series ICs
 74HC00 19p 74HC02 19p 74HC03 19p
 74HC04 19p 74HC08 19p 74HC10 19p
 74HC11 26p 74HC14 39p 74HC20 19p
 74HC27 31p 74HC30 35p 74HC74 38p
 74HC86 29p 74HC107 36p 74HC138 41p
 74HC161 48p 74HC175 52p 74HC393 69p

74LS series ICs
 74LS00 20p 74LS02 20p 74LS05 20p
 74LS30 20p 74LS32 20p 74LS51 20p
 74LS90 30p 74LS93 30p 74LS107 23p
 74LS112 23p 74LS138 35p 74LS139 35p
 74LS151 38p 74LS164 38p 74LS193 55p
 74LS245 58p 74LS374 52p 74LS375 64p

74F series ICs
 74F00 32p 74F02 32p 74F64 32p
 74F174 77p 74F251 64p 74F353 64p
 74F373 91p 74F398 96p 74F399 96p

ECL series ICs
 10101 1.15 10102 1.15 10103 1.15
 10104 1.15 10124 3.68 10125 3.68

A wide range of components and TTL, CMOS and
 ECL ICs are available. We also supply PC, XT and
 AT spares at **LOW PRICES**. Write or phone for our
FREE catalogue.

Resistors at bulk prices **Your Mix**
 Carbon film, 0.25W, 5% 1p each or 45p for 50
 Metal film, 0.25W, 1% 3p each or £1.35 for 100

IC sockets, solder type (pin:price)
 14:10p, 16:11p, 20:14p, 24(0.6 or 0.3):16p.

IC sockets with 0.1uF decoupler
 14:60p, 16:65p.

Prototyping boards (Verø)
 IBM XT £45.00, IBM AT £52.00

ACCESS welcome by post or phone. Callers by
 appointment please. VAT INCLUDED. Please add
 50p for post and packing. Catalogue free. No min-
 imum order charge.

BLACKMORE ELECTRONICS LTD.
 FREEPOST, Blandford Forum
 Dorset DT11 7BR

0258 451347 (24hr answerphone)

Series X Mixer Kits
 ★ up to 1,000 inputs
 ★ 60+ 100 mm faders, pots,
 panels and audio switches
 ★ 6-9 echo sends
 ★ versions for recording PA,
 radio, disco
 ★ circuit diagrams
 ★ From **£9.92**

Send 40p for catalogue to: K. Tek, P.O. Box 172a,
 Surbiton, Surrey KT6 6HN. Tel:01-399-3990



>>>RESISTOR PACKS<<<

**1/4W 5% CARBON FILM
 E12 RANGE 10R to 10M**

**10 of any 1 value 6p
 10 OF EACH VALUE
 Total 730 resistors
 £3.95**

Add 35p P&P & 15% VAT

**RMOS P.O. BOX 3
 USK GWENT NP5 2YF.**

BLACKMORE ELECTRONICS LTD.
 FREEPOST, Blandford Forum
 Dorset DT11 7BR

0258 451347 (24hr answerphone)

TURN YOUR SURPLUS
 ICS transistors etc into cash, immediate
 settlement. WE welcome the opportunity to
 quote for complete factory clearance.
 Contact:
COLES-HARDING & CO.,
 103 South Brink, Wisbech, Cambs.
 ESTABLISHED 15 YEARS
 Tel:0945 584188 - Fax: 0945 588844

**SURPLUS/REDUNDANT ELECTRONICS
 COMPONENTS WANTED**

ICs - Tuners - Transistors - Valves - Diodes etc - any
 quantity considered - immediate payment.
ADM ELECTRONICS SUPPLIES
 Tel 0827 873311 Fax: 0827 874835

Do not gamble with your advertising!
 Use Practical Electronics
 with confidence!
 Phone our Advertisement Dept. on
01-743-8888 for details!

CLASSIFIEDS

SERVICES

MAKE YOUR OWN PCBs



9x6 U.V. Lightbox	£85 - inc. timer.
1/2 ltr. Ferric Chloride crystals	£2.15
80 gms Sodium Hydroxide	£1.20
9x6 fibre Photoboard	single sided £4.80
	double sided £5.40

All other sizes available
Euro card 160mm x 100mm single sided £2.70
double sided £3.00

All other sizes available	
Antex soldering iron C17	£8.50
XS 25	£8.60
Solder 22swg	£7.50
Plastic etching trays	£3.50
Titan mini drill 12volt	£13.50

Include £1.00 P & P.

Just about everything from polishing blocks to plated through hole equipment. Very keen prices - discount on quantity.

S.A.E. for complete price list or telephone.

Ward Electronics, 27 North Street,
Redruth, Cornwall TR15 1HJ.
Tel: 0209 211050

We will make drilled PCBs to your specifications - one-offs to small production runs. Cost 6p/cm² single sided 12p/cm² double sided. An initial charge may be made for artwork transfer to acetate. Send your artwork to us or for further details contact Paul Oakes, PCB Production, Intec (Inverclyde) Ltd, 5 East Blackhall Street, GREENOCK, PA15 1HD.

For Electronic Design and PCB Manufacture call PROTO DESIGN

Unit 8, Ilford Trading Estate
Paycocke Road Basildon
Essex SS14 4DR
Tel: 0268 289923

TECHNICAL INFO SERVICES (PE)

76 Church St, Larkhall, Lanarkshire ML9 1HE
Phone 0698 884585 Mon-Fri, 9-5

any other time 0688 883334 FOR FAST QUOTES

WORLD'S LARGEST COLLECTION SERVICE MANUALS Most unobtainable elsewhere. Prices range from only £4.50 - large s.a.e. any quotation, no obligation to buy.

WORLD'S SOLE Suppliers of TV & Video Repair manuals, etc. from TV TECHNIC, Thorn etc. Every published service sheet in stock, supplied full size, not bits & pieces. CTV's or any combination £3.50 plus LSAE, any other single item £2.50 plus LSAE. Complete Circuit Sets for most Videorecorders only #7 set (no serv. shts made).

LSAE for QUOTATIONS plus GIANT CATALOGUE NEWSLETTERS BARGAINS FREE SHT as available.

Comprehensive TV Repair Manual £9.50. Complete Radio Service and Repair Course £9.50. Complete Repair & Service Manuals Mono TV £12.50; CTV £17.00; Video £19.50. Complete Repair Data with circuit - Mono TV £9.50; CTV £12.50; Video £10.50.

£3.00 plus LSAE BRINGS THE ONLY COMPREHENSIVE SERVICE SHEETS & MANUALS, CATALOGUES plus FREE CHASSIS GUIDE and £4.00 OF VOUCHERS

WORKSHOP SERVICE MANUALS

Video Recorders - £12.50

Most Colour TV, Audio, Test, Vintage, Amateur etc. £6.00
Please state Make/Model/Type with order.

FREE Catalogue Unique Repair and Data Guides with all orders or LSAE for your copy.

MAURITON ELECTRONICS LTD (PE),
8 Cherry Tree Road, Chino, Oxfordshire OX9 4QY
Tel: (0844) 51694

R.J.E COMPONENTS,

207, Godman Road,
Chadwell-St-Mary,
Grays, Essex RM1 6 4TR

Free Mail order catalogue of electronic components, Velleman project Kits, Tools etc.

Also

PCB Design - Manufacture - Assembly
Repair-Service Commercial PCB's & Equipment

SURVEILLANCE

ESKAN

ELECTRONICS

SURVEILLANCE & COUNTER SURVEILLANCE EQUIPMENT

WE MANUFACTURE AND SUPPLY TOP QUALITY SURVEILLANCE AND SECURITY EQUIPMENT



including VHF Transmitters, Automatic Telephone Recorders, Recording Briefcases, Bug Detectors, Telephone Counter-Tap Units

We also offer a complete range of accessories, including microcassette recorders, microphones, receivers, cassettes and batteries

ESKAN ELECTRONICS LTD.

DEPT. PE, 172 CALEDONIAN ROAD, LONDON N1

01-278 1768

CCTV AND SECURITY SYSTEMS SPECIALISTS

NEW VHF MICROTRANSMITTER KIT, tuneable 80-115 MHz, 500 metre range, sensitive electret microphone, high quality PCB. SPECIAL OFFER complete kit ONLY £5, assembled and ready to use £8.95 post free. Access orders telephone 021 411 1821. Cheques/ P.O.'s to: **Quantek Electronics Ltd, (Dept P.E.), 45a Station Road, Northfield, Birmingham, B31 3TE**

Surveillance devices, lasers, Tesla coils, scramblers, ultrasonic and many more, over 150 designs. Send SAE to: **Plancentre, Old Wharf, Dynock Road, Ledbury HR8 2HS**

KITS MICROTRANSMITTER, VHF/FM, received on standard radio, 25x15mm, free microphone included - £4.50. Telephone transmitter, amazingly uses no batteries - £5.49. Bleeper transmitter vhf - £8.59 inc p&p. SAE list. Remittance to: **A.C.E. (PE), 99 Greenheath, Hednesford, Staffs.** - Access orders 05438 71902 - same day dispatch.

We regret that due to circumstances beyond our control we are unable to publish the promised Display Electronics catalogue in this issue!

BOOKS

73 AMATEUR RADIO

World's leading ham radio magazine.

Annual subscription \$39.00 (US Funds)
from: 73 Amateur Radio, P.O. Box
58866, Boulder, CO 80322-8866, U.S.A.

JOBS

MUSIC VILLAGE - Require a service Engineer to work at their Chadwell Heath store, repairing amplifiers, keyboards, recording equipment and some computers. Training available. Ring Ian Woodcock on 01-597-7043

COMPONENTS

ELECTRONICS COMPONENTS & TEST EQUIPMENT - For bargain list send SAE to: Dept. PE, 76 Wensleydale Road, Great Barr, Birmingham B42 1PL

C.S. COMPONENTS (Est. 4 years). Suppliers & stockist of electronic components, electronic valves, military equipment and spares. Obsolete and hard to find products are our speciality. C.S. Components, Southfield House, 11 Liverpool Gardens, Worthing, West Sussex BN11 1RY

MISCELLANEOUS



Have a good idea?

Ideas, designs and inventions wanted.

S.A.E. for more information: Martin Bliss
Prop. MD, Adapta Plan, Dept. PE,
28 Clerkenwell Crescent, Malvern,
Worcs WR14 2TX

Laboratory stock clearance equipment, computers, ECG transducers, Geigers, anemometers, spare motors etc. SAE list. Laboratories, Maplehurst, RH13 6LL Tel: 0403 891 236.

VOICE/SOUND activated switches easy to follow diagrams and uses only £1.00. Components and P.C.Bs available: Herrington, 63 Home Farm Road, Hanwell, London W7 1NL.

RM Nimbus Experimental Analogue port. Two analogue and two digital channels, using mouse socket. Circuit, layout and listing £5.00; PCB £3.50. Logical Answers, 24 Elmwood, Mersea, Colchester, Essex CO5 8RD.

If the pocket radiotelephone turns out to be a popular consumer product, as seems likely in the UK, it could introduce yet another shift in the pattern of how we see ourselves in our highly technicised society.

What strikes me as significant - though it's not an original observation - is that your telephone number will no longer be tied to your home or workplace but will be roaming about with your person. This string of symbols will not identify a location, a particular assembly of bricks and mortar probably shared by other people, but an individual human being.

I'm referring, of course to the UK's proposed personal communications network (pcn). The Government officially floated this idea of a lower-cost, more accessible - what I would call cheap and cheerful - version of the cellular personal radiotelephone in a discussion document early this year. Several prospective operating companies responded

INDUSTRY



NOTEBOOK

argument that, if I know what "I am aware of electronics" means, I must know the meaning of "I" and hence know myself. But again this argument only leads to an intellectual requirement, a mental model, not to a real entity. And my awareness of self-sameness through memory (eg, remembering having heard the first stroke of a bell when listening to the second) is certainly a demonstration of psychological continuity but doesn't tell me anything about my individual self.

So, apart from a belief that personal identity resides in a non-corporeal substance and a suggestion that it is just psychological continuity, there are no satisfactory explanations of what constitutes the reality of self. It seems to me the symbol "I" can stand for any old definition of personal identity we care to make up. Let us, however, be severely practical.

Obviously, you can define personal identity by a lot of facts about yourself. To begin with,

"Sorry, wrong person!"

enthusiastically. Now, as I write, the DTI is examining formal applications for licences to run such pcn services.

Quite a lot of experience has been gained already. Cellphones have taken off rapidly in spite of their initially high cost, and the UK now has over half a million subscribers - mainly professional and managerial rather than residential. Cordless telephones (which of course use radio transceivers) are becoming quite familiar in homes. A telepoint service - with transceiver base stations dotted around public places - has just started in the UK. And next to arrive will be a pan-European digital cellular service and digital European cordless telephone system (the present cellphone services being analogue and not so efficient in using the spectrum).

EFFECTIVELY PINNED

Having yourself identified by a string of numbers or other symbols is, of course, a familiar part of modern life. What with your address wired telephone number, National Insurance code, bank account, credit cards, vehicle registration and many other labels, you are pretty effectively PINned down by a mass of intersecting data. Speaking for myself, I'm not worried by all this. I just forget most of the numbers most of the time and don't feel that the bureaucracies of government and commerce have any real hold on me as a person. Some people, though, are very paranoid about it.

But the pocket radiotelephone number could be different. It's not just another string of symbols to add to the rest. It's also an exclusive key to communication with that particular assemblage of feelings and

By Tom Ival

Numerology - the telling of personal fortunes by numbers - looks set to make a comeback.

thoughts, wishes and intentions, hopes and fears, pleasures and pains, that constitutes a unique human being. Communication between persons - from mind to mind - is what distinguishes us from other animals. This new number seems to me more like a name, as a determinant of identity.

SELF ASSESSMENT

What, after all, does personal identity consist of? We assume that there is something essential called "I" at the core - the self, psyche, ego or soul. But what exactly is it? If I try to look for it inside myself I merely find a succession of different sensations, impressions, emotions, thoughts, ideas etc. These experiences seem to have some kind of continuity and relatedness and I feel they must all be part of the entity called "I". But this version of "I" is really nothing more than an intellectual requirement - a necessary concept without which one can't understand how the perceptions can occur.

A 'self' which is no more than an intellectual requirement doesn't have an independent existence. There's an old

there is the particular structure of your body. This can be specified anatomically in great detail by its molecules - and nowadays using the new technique of DNA 'fingerprinting'

Next comes the characteristic behaviour of your body: how you walk, sit, stand, speak, gesture, chew food, laugh and do all those things which collectively demonstrate consciousness and express what is called the personality.

Then there is the set of names and titles given to "I" by its parents and others. This may seem a rather contingent and extrinsic feature of a person, but it's certainly a practical criterion of identity - and an enduring one, because it stays recorded somewhere after that person dies.

MAJORITY VOTE

I've picked out just three groups of attributes because you need a minimum of three candidates to allow a 'majority vote' decision. In a life subject to change, if at least two of these three groups remained unaltered then you could say reasonably that the personal identity was maintained. Of course, many other attributes could be taken into account and the majority decision could be on, say, an 80% - 20% basis.

So, in the absence of any really definite knowledge about the essential self, apart from intuitive insights, in practice we do rely a great deal on purely factual data to establish personal identity. An important category of this data is that of forenames and surnames and all the numbers and codes which get attached to them like barnacles as we move through life. Among these names, numbers and symbols the pocket radiotelephone number must evoke a distinctive resonance. Its sequence of numerals are equivalent to the letters of a person's name.

PE



PRACTICAL ELECTRONICS BOOK SERVICE

Here is your Editor's choice of books he thinks will be of interest to electronics and computer enthusiasts

BEGINNERS AND EARLY STARTERS

NEW Mini-Matrix Board Projects.

R.A.Penfold. 112 pages. £2.50.

Order Code BP99

Shows a selection of 20 useful and interesting circuits that can be built on a mini-matrix board of 24 holes by 10 copper strips in size - an ideal book for early experimenters.

NEW From Atoms to Amperes.

F.A.Wilson. 160 pages. £2.95.

Order Code BP254.

For the absolute beginner, clearly explaining the fundamentals behind the whole subject of electricity and electronics.

NEW Electronic Projects for Beginners.

F.G.Rayer. 128 pages. £1.95.

Order Code BP48

Specially for the newcomer to electronics who is looking for a book containing a wide range of easily made projects. Some circuits need no soldering and many others show actual component and wiring layouts.

Electronics Build and Learn

R.A.Penfold. 128 Pages. £5.95.

Order Code PC 101

Combining theory and practice, the book describes a circuit demonstrator unit that is used in subsequent chapters to introduce common electronic components and circuit concepts, complete with practical experiments.

Practical Electronic Building Blocks

R.A.Penfold. There are two books -

Book 1 : 128 pages. £1.95.

Order Code BP117

Book 2 : 112 pages. £1.95.

Order Code BP118

Book 1 is about oscillators and gives circuits for a wide range, including sine, triangle, square, sawtooth and pulse waveforms and numerous others from voltage controlled to customised ic types.

Book 2 looks at amplifiers, ranging from low level discrete and opamp types to ic power amps. A selection of mixers, filters and regulators is included.

30 Solderless Breadboard Projects

R.A.Penfold. Two books each of 160

pages. Book 1 : £2.25. Order Code

BP107. Book 2 : £2.25. Order Code

BP113.

Each project is designed for building on a Verobloc breadboard and is accompanied by a description, circuit and layout diagrams and relevant constructional notes. Many of the components are common to several projects. Book 1 covers linear devices, and Book 2 covers cmos logic chips.

Beginners Guide to Building

Electronic Projects R.A.Penfold. 112

pages. £1.95. Order Code BP 227

Shows the complete beginner how to tackle the practical side of electronics and includes simple constructional projects.



TEST AND MEASUREMENT

Getting the Most from Your Multimeter

R.A.Penfold. 112 pages. £2.95.

Order Code BP239

There's more to what you can do with a meter than meets the casual eye. The book covers the basics of what you can do with analogue and digital meters and discusses component and circuit testing.

NEW Test Equipment Construction

R.A. Penfold £2.95.

Order Code BP248

Describes in detail how to construct some simple and inexpensive, but extremely useful, pieces of test equipment.

Oscilloscopes

I.Hickman. £6.95.

Order Code NT3

Subtitled 'How to Use Them, How They Work' the book is illustrated with diagrams and photographs and is essential reading for any one who wants to know about scopes, from first principles to practical applications.

How to Get Your Electronic Projects Working.

R.A.Penfold. 96 pages. £2.50.

Order Code BP110.

Essential reading for anyone who wants first-time success in project assembly. Covers tracing mechanical faults as well as testing for failures of active and passive components of most types.

SATELLITE TV

NEW Satellite TV Installation Guide - 2nd edition John Breeds. £11.95. Order Code STV1

Full of vital information for any competent diyer who wishes to install a satellite tv antenna and obtain optimum reception quality.

An Introduction to Satellite Television

F.A.Wilson. 112 pages. £5.95.

Order Code BP195

Informative answers to many of the questions about this communications revolution. The information is presented on two levels, one aimed at the complete beginner, the other at professional engineers and serious amateur enthusiasts.

AUDIO AND MUSIC

Introducing Digital Audio

I.Sinclair. 112 pages. £5.95.

Order Code PC102

A non-mathematical introduction to the new digital technology, discussing the principles and methods involved in devices such as cd, dat and sampling.

Electronic Music Projects

R.A.Penfold. 112 pages. £2.50.

Order Code BP74

24 practical constructional projects covering fuzz, wah, sustain, reverb, phasing, tremolo etc. The text is split into four sections covering guitar, general, sound generation and accessory projects.

More Advanced Electronic Music Projects

R.A.Penfold. 96 pages. £2.95.

Order Code BP174

Complementing BP74 by covering more advanced and complex projects including flanging, chorus, ring modulation, plus a selection of drum, cymbal and gong circuits.

NEW Computer Music Projects

R.A.Penfold. 112 pages. £2.95.

Order Code BP173

Shows how home computers can produce electronic music and covers sequencing, analogue and Midi interfacing, digital delay lines and sound generators.

Practical Midi Handbook

R.A.Penfold. 160 pages. £5.95.

Order Code PC103

A practical how-to-do-it book for musicians and enthusiasts who want to exploit the capabilities of Midi. Covers keyboards, drums, sequencers, effects, mixers, guitars, and computer music software.

Midi Projects

R.A.Penfold. 112 pages. £2.95.

Order Code BP182

Practical details of interfacing many popular home computers with Midi systems, and also covering Midi interfacing to analogue and percussion synths.

NEW Electronic Synthesiser Construction.

R.A.Penfold. 112 pages. £2.95.

Order Code BP185.

Even relative beginners should find the monophonic synthesiser described here within their capabilities if the book is thoroughly read. Individual aspects of the synth are dealt with separately and pcb designs are shown for the main modules.

DIGITAL AND COMPUTING

NEW A Concise Introduction to MS-DOS.

N. Kantaris. 64 pages. £2.95.
Order Code BP232

A ready-reference guide for those who need a quick insight into the essential command functions of this operating system, but who don't have the time to learn it fully.

An Introduction to Computer Peripherals

R.A. and J.W. Penfold. 80 pages.
£2.50. Order Code BP170

Covers such items as monitors, printers, disc drives, cassettes, modems, etc, explaining what they are and how to use them with your computer and with each other.

Microprocessing Systems and Circuits

F.A.Wilson. 256 pages. £2.95,
Order Code BP77

A comprehensive guide to the elements of microprocessing systems, covering the fundamental principles behind this important subject.

Introduction to 6800/6802 Microprocessor Systems

R.J.Simpson and T.J.Terrell. 238 pages. £10.95. Order Code NT9

The book covers systems hardware, programming concepts and practical experimental work that will assist in understanding the 6800/6802 microprocessor, with additional information on the 6802D5E evaluation system.

NEW An Introduction to 68000 Assembly Language.

R.A. and J.W.Penfold. 112 pages.
£2.95. Order Code BP184

Covers the fundamentals of writing programs that will vastly increase the speed of 68000 based machines such as the Commodore Amiga, Atari ST range, Apple Macintosh, etc.

Getting the Most from Your Printer

J.W.Penfold. 96 pages. £2.95.

Order Code BP181

How to use the features found on most dot-matrix printers from programs and popular wordprocessors, showing examples of what must be typed to achieve a given effect.

Micro Interfacing Circuits

R.A.Penfold. Two books, each of 112 pages.

Book 1 : £2.25. Order Code BP130.

Book 2 : £2.25. Order Code BP131

Both books include practical circuits and useful background information though pcb layouts are not included. Book 1 mainly covers computer input-output techniques. Book 2 deals primarily with practical application circuits.

NEW An Introduction to 6502 Machine Code.

R.A. and R.W. Penfold. 112 pages.
£2.50. Order Code BP147

Covers the main principles of machine code programming on 6502-based machines such as the Vic-20, Oric-1/Atmos, Electron, BBC and Commodore 64. It assumes no previous knowledge of microprocessors or machine code and gives illustrative programming examples.

NEW A Z-80 Workshop Manual.

E.A.Parr. 192 pages. £3.50.
Order Code BP112

A book for those who already know Basic but wish to explore machine code and assembly language programming on Z80 based computers.

Practical Digital Electronics Handbook

M.Tooley. 208 pages. £6.95.
Order Code PC 104

Nine constructional projects introduce digital circuits, logic gates, timers, microprocessors, memory and interface circuits - an essential book for anyone interested in digital devices.

DATA AND INFORMATION BOOKS

Digital IC Equivalents and Pin Connections

A.Michaels. 320 pages. £5.95.
Order Code BP140

Linear IC Equivalents and Pin Connections

A.Michaels. 256 pages. £5.95.
Order Code BP141

Between them these two books show equivalents and pin connections of a popular user-orientated selection of European, American and Japanese ICs. They also include details of functions, manufacturer and country of origin. The Digital ICs book also quotes details of packaging and families.

Opamps

B.Dance. £6.50.

Order Code NT2

Subtitled 'Their Principles and Applications' this interesting book is written in a simple non-mathematical style and provides a source of practical circuits that use both commonplace and more sophisticated opamps.

Electronic Hobbyists Handbook

R.A.Penfold. 96 pages. £4.95. Order Code BP233

Provides a source of useful information that the amateur enthusiast is likely to need for day-to-day pursuance of hobby electronics.

Practical Electronics Handbook

I. Sinclair. £7.95.

Order Code NT1

A useful and carefully selected collection of standard circuits, rules-of-thumb and design data for enthusiasts, students and engineers involved in radio, computing and general electronics

Newnes Electronics Pocket Book

I.E.Parr. £6.95.

Order Code NT10

Presents all aspects of modern electronics in a readable and largely non-mathematical style, and is a good source of valuable information for enthusiasts and professional engineers alike.

NEW Key Techniques for Circuit Design

G.C. Loveday. £6.95.

Order Code BM 101

Tackles the problems of designing circuits from scratch, introducing the concept of target specifications, the design sequence, device selection, rules of thumb, and useful equivalent circuits.

GENERAL CONSTRUCTIONAL

NEW Electronic Science Projects.

Owen Bishop. 144 pages. £2.95.
Order Code BP104

A bumper bundle of experimental projects ranging in complexity and including a colour temperature meter, electronic clock, a solid state (led display) scope, an infra-red laser, a fascinating circuit for measuring the earth's electrical field strength, and many more.

Electronic Security Devices

R.A.Penfold. 112 pages. £2.50. BP56

Full of ideas for keeping your valuables safe. The circuits include designs for light, infra-red, ultrasonic, gas, smoke, flood, door and baby sensors.

NEW More Advanced Electronic Security Projects. R.A.Penfold. 112 pages. £2.95. Order Code BP190

Follows on from where BP56 leaves off and describes a number of more up-to-date and sophisticated projects, such as pyro-sensors, infra-red and doppler-shift detection, fibre-optic loops, and many others.

NEW Electronic Projects for Cars and Boats.

R.A.Penfold. 96 pages. £1.95.
Order Code BP94

15 fairly simple projects that can be used with a car and/or boat. Stripboard constructional details are included, as are explanations of the circuit theory.

Power Supply Projects

R.A.Penfold. 96 pages. £2.50.
Order Code BP76

A selection of power supply designs, including simple unregulated, fixed voltage regulated and variable voltage stabilised, ni-cad charger, voltage step-up, and inverter.

More Advanced Power Supply Projects

R.A.Penfold. 96 pages. £2.95.
Order Code BP192

Covers more advanced topics than BP76 and includes precision supplies, switch mode and computer controlled supplies, plus a selection of miscellaneous circuits.

NEW Popular Electronic Circuits.

R.A.Penfold. 160 pages. £2.95.
Order Code BP80

Containing a wide range of circuit designs for experienced constructors who are capable of producing working projects direct from a circuit diagram without specific constructional details.

HOW TO ORDER

State your order code and your name and address clearly. Enclose a cheque, PO or international money order (add 50p postage per book - £1.00 for overseas surface mail), and send to:

PE Book Service
Intra House
193 Uxbridge Road
London W12 9RA

Books are normally delivered within 10 days but please allow 28 days for delivery.

INDEX

JANUARY 1989 TO DECEMBER 1989

VOLUME 25

Constructional Projects

- 64-Line Output Port** by R.Milner and A.Horsman. Multiplexes 64 control lines from any 8-bit computer. **September**
- Ask PE** by Andrew Armstrong. A frequent series of answers to reader's technical questions. **September**
- Audio level remote control.** **September**
- Amplifier signal feedback stability and line regulation.** **October**
- Extended timing where analogue is unsuitable.** **November**
- Logic gates select and control extended timing.** **December**
- Camera Shutter Timer** by Robert Penfold. Infrared techniques check camera shutter timing accuracy. **March**
- Christmas Flashers** by Chris Bowes. Several flashing light projects for sprucing up the Xmas fir tree. **January**
- Digital Electronics** by Owen Bishop. Tutorial features for GCSE and other students of electronics. **January**
- Part five - interfacing.** **February, March**
- Part six - converters.** **April**
- Part seven - Computer logic.** **May**
- Part eight - More computer logic.** **June**
- Part nine - Computer systems.** **July**
- Part ten - Programming computer systems.** **September**
- Part eleven - Applications and implications.** **October**
- Part twelve - Conclusions.** **October**
- Dual Beam Oscilloscope** by John Becker. Part three - the Y amps and advice on using a scope. **January**
- Easi-Build Series** by John Becker. A series of simple, useful circuits. **September**
- Compressor.** Automatic audio signal level controller. **December**
- Metronome.** Variable-rate flashing led and audio accented beat setter. **July**
- Power Supply.** Multipurpose fixed or variable stabilised voltage regulator. **May**
- Remote-a-Bell.** Inductive remote phone line monitor. **August**
- Vodalek.** Robot-type voice modifying project. **October**
- Voice Operated Switch.** Sound triggered remote switching circuit. **June**
- Wheebly-Jeeby Siren.** Multiple variable siren generator. **July**
- Electronic Thumb** by Owen Bishop. A workshop test aid for searching out hot spots. **July**
- Frequency Counter and Generator** by John Becker. 4MHz frequency counter with lcd, plus dual audio and digital signal generators. **September, October**
- Hand Clapper** by Harvey Kent. Triggered and automatic hand clap effects generator. **August**
- HF Scope Store** by Michael Sweet. An add-on circuit for the 1988 logic analyser, allowing a BBC-B to act as a storage scope. **March**
- Holmes Machine** by Owen Bishop. Stepper-motor controlled mobile silhouette unit for deceiving thieves. **January**
- Home Security Controller** by Kevin Browne. Microprocessor controlled alarm system monitor. **September, October**
- Kirlian Camera** by Don Phillips. A solid-state camera for recording paranormal events. **May**
- Metronome Deluxe** by Robert Penfold. A precision musical beat timer. **June**
- Mole-Detester** by Edwin Chicken. Electronic mole-detering sound generator. **September**
- Mono -Stereo Echo Station** by John Becker. Multi-option audio delay-line unit for echo, reverb, multitracking, chorus, etc. **October, December**
- PC Multiport** by Philip Small. 8-line dual analogue/digital interface port for Amstrads and other PCs. **April**
- Projector Synchroniser** by Chris Bowes. Interfacing a slide projector and stereo taperecorder. **July**
- Siderial Clock** by John Becker. For astronomical or conventional timekeeping. **February**
- Solar Heating Controller** by Andrew Williams. A control circuit using high accuracy temperature sensors. **June**
- Stepping Motor Driver** by Mark Stuart. Uses the M5804 chip to interface a home micro to motor controlled models. **August**
- Telescope Control Interface** by David Clarke. Versatile parallel-serial computer interface for controlling telescopes or other devices. **October, November**
- Thermal Conversion Voltmeter** by Rod Cooper. A follow on from the True RMS Meter of June. This meter is designed for use in power electronics. **December**
- True RMS Meter** by Rod Cooper. Examining problems in power measurement, and a constructional solution. **June**
- Video AGC Stabiliser** by Robert Penfold. Assists in improving stability of poor quality hired video tapes. **December**

25th Anniversary Features

- Paralleling Sir Clive** by John Becker. An interview with Sir Clive Sinclair. **November**
- In the Beginning** by Fred Bennett. PE's founding editor tells how it all began. **November**
- The Middle Years** by Mike Kenward. A mini-memoire from PE's editor 1977-85. **November**
- Time Travelling Through Technology** by John Becker. A nostalgic trip through PE's history. **November**
- Toasting Transitions** by Richard Barron. Celebratory good wishes from PE's editor during 1986. **November**
- Future Fulfilment** by John Becker. Incumbent Editor since 1987 recalls his call-up and looks to PE's future. **November**
- 2014? Whew!** by Wayne Green. Our American correspondent's personal view of technology past and future. **November**
- The Next 25 Years** by Barry Fox. Speculations on technology's future from PE's Leading Edge columnist. **November**
- 25 Years of I.T.** by Tom Ivall. A retrospective review of Information Technology from PE's Industry Notebook columnist. **November**
- From PE to Prosperity** by Anthony H. Smith. Building a PE project set a reader in search of fortune - and he found it! **November**
- Fleming and the Valve** by John Becker. Commemorating the 85th anniversary of the invention of the valve. **November**
- A Party to Remember** by John Becker. How PE and friends celebrated the 25th Birthday! **December**

Special Features

Autoguide by Michael Strassen. Reporting on the status of the new automatic traffic guidance system. **March**

Boating Revolution by John Becker. Reviewing the status of technology for leisure craft electronic products. **June - August**

Digital Multimeters by Samuel Dick. Choosing DMMs, and their advantages over analogue meters. **May**

Electronic Railways by Neil Harding. How countless electronic systems assist rail transportation. **January, February**

Electronic Snapshots by Barry Fox. Reviewing the status of solid-state still-photography. **October**

Electronica 88 - Munich by John Becker. A review of the World's largest component exhibition. **February**

Encryption by Mike Sanders. Explaining coding and decoding techniques for linguistic security. **July - September**

HDTV - The Great Systems Battle by Tom Ivald. The contemporary state of high definition tv. **February, March**

HF Radio by Mike Sanders. An explanation of the hows and whys of radio reception. **August - December**

Hi-Tech Timing by Anthony H. Smith. (Time and Frequency series). Atomic frequency standards. **April, May**

Home Automation by John Becker. Reviewing the current status of the major fields in this technology. **April, May**

Micro Genius by Jenny Welsh. A cautionary tale of what to expect from a Home Computer! **November**

Reader Survey. Seeking readers' opinions about PE. **May**

Repairing the AL80 by Vivian Capel. How to keep the obsolete but much favoured AL80 amplifier module in good condition. **December**

Satellites by Tom Ivald

Part one - Spacecraft launching and orbiting. **April**

Part two - Receiving satellite signals. **June**

Part three - Signal coding and polarising. **July**

Semiconductors by Andrew Armstrong.

Part thirteen - Opamps. **February**

Part fourteen - Audio circuits. **March**

Part fifteen - Signal conditioning. **April**

State-Side - WCES 89 by Wayne Green. An American's personal view of the Las Vegas Winter Consumer Electronics Show. **May**

Tactile Deaf Aid by Vincent Johns. Reviewing a sensor which allows the deaf to become aware of sounds. **March**

Telepointing the Way by Michael Strassen. Reviewing the new Forum Telepoint personal telephone. **May**

The Thor Spot by Wayne Green. Our American correspondent looks at the current situation regarding cd-rom. **March**

Time and Frequency Measurement by Anthony H. Smith.

Part three - quartz crystal timebase. **February**

Part four - quartz crystal stability. **March**

Transputer Trainer Review by Robert Penfold. Reviewing Flight Electronics' transputer training system. **October**

UCT Measurements by Anthony H. Smith. How to maximise the accuracy of counter-timer measurements. **November, December**

Regular Features

Editorial by John Becker. Monthly views and comments from the Editor.

Industry Notebook by Tom Ivald. Monthly series looking at the electronics industry.

Leading Edge by Barry Fox. Monthly series looking at the technology behind the news.

Spacewatch by Dr Patrick Moore CBE. Monthly series of astronomy and space reports.

Bookmark. Frequent reviews of new books received.

Catalogue Database. Monthly reviews of catalogues received.

Chipcount. Monthly look at selected new chips.

Countdown. Monthly list of forthcoming exhibitions.

News and Marketplace. Monthly series detailing new products and services.

Readers' Letters. Frequent series expressing your views, and offering a few replies.

Competitions

Astra Satellite tv aerial system - competition **February**, results **June**

Atari Folio pocket pc - competition **July**, results **November**

Ferguson pocket lcd colour tv - competition **January**, results **April**

Forum Telepoint telephone - competition **May**, results **August**

Maplin 20MHz oscilloscope - competition **Sept**, results **December**

Sharp IQ-7000 personal organiser - competition **August**, results

November

Acorn Archimedes A3000 computer, Cirkit digital multimeters, 25 years' subs to PE - competition **November**

Summary Points

Dual Beam Oscilloscope (Dec 88)

Fig.20 page 27, C15 should be across the +5V lines, VR3 goes to -VE (not 0V); the pcb is correct. C9 1 in parts list should read C9.

Easi-Build Remote-a-Bell (May 89)

Fig.2, reverse polarities of D1 and D2. IC1 pin 1 is at top left. R1 should be inserted in place of link wire D to M, but taking it to L instead of M.

Kirlian Camera (May 89)

Fig.3, C1 polarity should be reversed. PCB point B should read as T1 common. PCB point C should just read as T1+. Fig.1, the coil output arrow should be marked as EHT to Plate. Fig.5, connection GND should go to pcb point A. The EHT plate and glass may be replaced by copper-clad fibreglass with a one inch strip of copper removed from edges.

Panning Mixer (Dec 88)

Fig.4, C15 +VE should go to +15V line, the pcb is correct. Fig.6, second IC3 should be IC5.

PC Multiport (Apr 89)

Fig.3, links holes adjacent to IC9 pin 4 and IC10 pin 13, link holes next to IC10 pins 4 and 13, link holes next to IC10 pin 5 and +5V, link hole

next to IC8 pin 1 and digital ground (anywhere will do). Fig.2, A32 should read A31, B15 should read B13.

Polywhatsit! (May-Jun 87)

Fig.5 May 87, leads 11 & 12 should go to either of the two outer transformer secondaries. Jun 87 pcb: check that IC16 pin 9 is separated from track to IC16 pins 8/10, and track to IC18 pin 3 is separated from IC18 pins 4/13. As stated in Dec 88, there are minor errors on the circuit diagram Fig.2 Jun 87, but the pcb component layouts and wiring diagrams are correct.

Siderial Clock (Feb 89)

Fig.11, VR1 should read as C5

Solar Heating Controller (Nov 89)

The LM335 sensors are available from STC Electronic Services (0279 626777) and Viewcom Electronics (01-471 9338). C4 is 1000uF 35V.

Vodalek (Aug 89)

Fig.1. Bottom of VR2 goes to 0V, C10 +VE goes to TR1 gate, TR1 drain goes to R9/R11. Pin numbering of IC1c and IC1d should be transposed. The pcb is correct.

Weather Centre (May 88) Fig.20, IC8 should be reversed.



NATIONAL
COLLEGE OF
TECHNOLOGY

Packaged Short Courses

The National College of Technology (NCT Ltd) offers a range of packaged short courses in analogue electronics, digital electronics and fibres & optoelectronics for study at home or at work. The advantages are that you may,

- commence at any time
- work at your own pace
- have a tutor (optional)

and there is no travelling involved. BTEC certificates are available subject to the conditions of the award. These highly popular packed courses contain workbooks, a cassette tape, circuit board and components necessary to provide both theoretical and practical training.

Whether you are a newcomer to electronics or have some experience and simply need updating, there is probably a packaged short course ready for you. Write or telephone for details, quoting Practical Electronics, to:

NCT Ltd, Bicester Hall
5 London Road, Bicester
Oxon OX6 7BU
or telephone (0296) 613067 Ext. 202

Interak 1 SINGLE BOARD COMPUTER

"SBC-1"

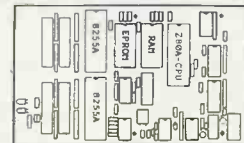

A computer doesn't have to look like you'd expect a computer to look. It doesn't have to have a keyboard and a screen and floppy disks and so on.

The SBC-1 has the bare minimum of chips a Z80 computer can have and still be a computer: A 4 MHz Z80-CPU chip, an EPROM chip (up to 32K), a static RAM chip (up to 32K) and a pair of 8255A I/O (input/output) chips giving 48 individual lines to waggle up and down. There are one or two additional "glue" chips included, but these are simple "74LS" or "HC" parts.

A star feature is that no special or custom chips (ie PALS, ULAs, ASICs etc) are used — and thus there are no secrets. The Z80A is the fastest and best established of all the 8-bit microprocessors — possibly the cheapest too!

Although no serial interface is included, it is easy for a Z80A to waggle one bit up or down at the appropriate rate — the cost is a few pence worth of code in the program: why buy hardware when software will do?

Applications already identified include: Magnetic Card reader, mini printer interface, printer buffer, push button keypad, LCD alphanumeric panel interface, 40-zone security interface for auto sending of security alarms, code converter (eg IBM PC keyboard codes to regular ASCII), real time clock (with plug in module), automatic horticultural irrigation controller.

By disabling the on-board Z80A-CPU this card will plug into our Interak 1 CP/M Plus disk-based development system, so if you don't fancy hand-assembling Z80 machine code you don't have to!

The idea is (if you are a manufacturer) you buy just one development system and then turn out the cheap SBC-1 systems by the hundred. If you are really lazy we can write the program for you and assemble the SBC-1 cards so you can get on with manufacturing your product, leaving all your control problems to us.

Greenbank

For more details write or phone us:
Greenbank Electronics, Dept (E10P) 460 New Chester Road,
Rock Ferry, Birkenhead, Merseyside. L42 2AE. Tel: 051-645 3391

INDEX TO ADVERTISERS

A & G Electronics.....54	London Underground.....53
A.D.M. Electronics Supplies.....55	Magenta Electronics.....32,33
Antex Electronics.....39	Maplin Electronics.....OBC
Astronomy Now.....47	Martin Bliss.....56
B.K. Electronics.....IBC	Mauriton Electronics.....56
Blackmore Electronics.....55	National College of Technology.....62
Bull J.....52	National Component Club.....32
Cambridge Computer	Number One Systems.....26
Science Ltd.....55	Omni.....54
Classified Ads.....54-56	Phonosonics.....29
Coles Harding.....55	Program Now.....43
Cooke International.....55	Proto Design.....56
Cricklewood Electronics.....19	Radio and Telecommunications
C.R. Supply Co.....55	Correspondence School.....54
Deansgate.....54	R.J.E. Components.....56
Electronize Design.....40	RMOS.....55
Electrovalue.....39	Service Trading Co.....62
Eskan.....56	SM Engineering.....34
Fraser Electronics.....54	Soft Machine.....43
Global Electronic Services.....39	Specialist Semiconductors.....16
Greenbank Electronics.....62	Stewart of Reading.....40
Hanney, L.F.....54	Suma Designs.....34
Hills Components.....40	Tandy.....IFC
Intec.....56	Technical Info Services.....56
J.P.G. Electronics.....55	Technomatic.....10,11
Keytronics.....20	T.K. Electronics.....34
K-Tek.....55	Ward Electronics.....56
London Electronics College.....54	

**PLEASE MENTION PRACTICAL ELECTRONICS
WHEN REPLYING TO ADVERTS**

VARIABLE VOLTAGE TRANSFORMERS

INPUT 220/240V AC 50/60	OUTPUT 0-260V
200W 0.1 amp max £24.99 p&p	£3.90 (£31.05 inc VAT)
0.5KVA 2.5 amp max £26.50	£3.75 (£34.75 inc VAT)
1KVA 5 amp max £34.00	£4.25 (£43.99 inc VAT)
2KVA 10 amp max £49.00	£5.50 (£62.68 inc VAT)
3KVA 15 amp max £65.00	£6.25 (£81.94 inc VAT)
5KVA 25 amp max £115.00	

Carnage on request

VOLTAGE CHANGING TRANSFORMER

1250 Watt auto. Tapped 0-90V, 100, 110, 115, 120, twice to obtain voltages between 90 and 240V. Fitted in heavy duty louvered metal case. Fused input. Price incl VAT & p&p £39.50.

COMPREHENSIVE RANGE OF TRANSFORMERS-IT- ISOLATION & AUTO (110-240V Auto transfer either cased with American socket and mains lead or open frame type. Available for immediate delivery.

ULTRA VIOLET BLACK LIGHT FLUORESCENT TUBES

4R 40 watt £10.44 (£12.00 inc VAT)	Caller only (£9.99 inc VAT)
2R 20 watt £7.44 + £1.25 p&p	(£7.53 inc VAT)
13in 10 watt £5.80 + 75p p&p	(£6.38 inc VAT)
12in 8 watt £4.80 + 75p p&p	(£5.12 inc VAT)
9in 6 watt £3.60 + 50p p&p	(£3.75 inc VAT)
6in 4 watt £3.60 + 50p p&p	(£3.75 inc VAT)

230V AC BALLAST KIT for either 6in, 9in or 12in tubes £5.50 + 50p p&p (£6.96 inc VAT)
For 13in tubes £6.00 + 75p p&p (£7.75 inc VAT)

400 WATT UV LAMP

Only £34.00 + £2.50 p&p (£41.98 inc VAT)

175 WATT SELF BALLASTED BLACK LIGHT MERCURY BULBS

Available with BC or ES fitting. Price incl VAT & p&p £19.84.

12 VOLT BILGE PUMPS

Buy direct from the importers

500 GPH 15ft head 3 amp	£16.00 inc.
1750 GPH 15ft head 9 amp	£19.25 + £2.00 p&p (£25.00 inc VAT)

EPROM ERASURE KIT

Build your own EPROM ERASURE for a fraction of the price of a made-up unit. Kit of parts less case includes 12in 9 watt £337 Argat Tube Ballast unit pair of 8-pin leads neon indicator on/off switch safety microswitch and circuit £14.00 + £2.00 p&p (£16.40 inc VAT)

SUPER HY-LIGHT STROBE KIT

Designed for Disco, Theatrical users etc. Approx 16 joules. Adjustable speed £48.00 + £2.00 p&p (£57.50 inc VAT)

Case and reflector £22.00 + £2.00 p&p (£27.60 inc VAT). SAE for further details including Hy-Light and Industrial Strobe Kits.

Ample Parking Space
Showroom open Monday/Friday

SERVICE TRADING CO
57 BRIDGMAN ROAD, CHISWICK, LONDON W4 5BB
01-995 1560
ACCOUNT CUSTOMERS MIN. ORDER £10

WIDE RANGE OF XENON FLASH TUBES

Write/Phone your enquiries

WASHING MACHINE WATER PUMP

Brand new 240V AC fan cooled can be used for a variety of purposes. Inlets 1 1/2 ins. Outlet 1 inch. Price including p&p and VAT — £10.95 or 2 for £20 including p&p and VAT.

SPECIAL OFFER AC CAPACITORS

1.5 MFD 440V £2.00	5 MFD 440V £4.00
2 MFD 440V £2.50	5.4 MFD 280V £2.00
4.1 MFD 440V £3.50	5 MFD 660V £3.00
	12 MFD 400V £4.00

p+p 50p per unit plus VAT to be added to total.

TORIN CENTRIFUGAL BLOWER

230V ac 2.800 RPM 0.9amp 130mm diameter impeller outlet 63 x 37mm overall size 195 x 160 x 150mm long. Price £17.50 + £2.50 p&p (£23 inc VAT)

SHADED POLE GEAR MOTORS

In the following sizes:
9 RPM 12 RPM 80 RPM 160 RPM 110V AC or 240V AC with capacitors (supplied). Price incl VAT & p&p £12.65

GEARED MOTORS

71 RPM 20lb inch torque reversible 115V AC input including capacitor and transformer for 240V AC operation. Price incl VAT & p&p £23.00.

12 V DC COOLER EXTRACTOR FAN

New brushless motor 92mm sq. Price incl VAT & p&p £11.50.

SOLID STATE EHT UNIT

Input 230/240V AC. Output approx 15KV. Producing 10mm spark. Built-in 10 sec timer. Easily modified for 20 sec, 30 sec to continuous. Designed for boiler ignition. Dozens of uses in the field of physics and electronics, eg supplying neon or argon tubes etc. Price less case £8.50 + £1.00 p&p (£10.93 inc VAT) NMS

COOLING FANS-BRAND NEW!

200/400V AC American Boxer 'Peewee' 7-bladed high efficiency cooling unit 80mm sq xz 40mm deep 40cm approx. Price incl VAT & p&p £10.35.

EX-EQUIPMENT FANS 120mm sq x 38mm deep in either 115V or 230V AC Tested and guaranteed. Price incl VAT & p&p £7.75.

Large selection of various speed geared motors from stock. Phone or write for details.

From stock at prices that defy competition
C/F Blowers Program Timers
Microswitches Synch Motors
write/phone your enquiries

NMS = NEW MANUF SURPLUS
R&T = RECONDITIONED AND TESTED



POWER AMPLIFIER MODULES-TURNABLES-DIMMERS-LOUDSPEAKERS-19 INCH STEREO RACK AMPLIFIERS

OMP POWER AMPLIFIER MODULES

Supplied ready built and tested.

OMP POWER AMPLIFIER MODULES

Now enjoy a world-wide reputation for quality, reliability and performance at a realistic price. Four models available to suit the needs of the professional and hobby market, i.e., Industry, Leisure, Instrumental and Hi-Fi etc. When comparing prices, NOTE All models include Toroidal power supply, Integral heat sink, Glass fibre P.C.B., and Drive circuits to power compatible Vu meter. Open and short circuit proof.

THOUSANDS OF MODULES PURCHASED BY PROFESSIONAL USERS



OMP100 Mk 11 Bi-Polar Output power 110 watts R.M.S. into 4 ohms, Frequency Response 15Hz – 30KHz – 3dB, T.H.D. 0.01%, S.N.R. – 118dB, Sens. for Max. output 500mV at 10K, Size 355 x 115 x 65mm.
PRICE £33.99 + £3.00 P&P.

NEW SERIES II MOS-FET MODULES



OMP/MF 100 Mos-Fet Output power 110 watts R.M.S. into 4 ohms, Frequency Response 1Hz – 100KHz – 3dB, Damping Factor, >300, Slew Rate 45V/uS, T.H.D. Typical 0.002%, Input Sensitivity 500mV, S.N.R. – 125dB. Size 300 x 123 x 60mm.
PRICE £39.99 + £3.00 P&P.



OMP/MF200 Mos-Fet Output power 200 watts R.M.S. into 4 ohms, Frequency Response 1Hz – 100KHz – 3dB, Damping Factor >300, Slew Rate 50V/uS, T.H.D. Typical 0.001%, Input Sensitivity 500mV, S.N.R. – 130dB. Size 300 x 155 x 100mm.
PRICE £62.99 + £3.50 P&P.



OMP/MF300 Mos-Fet Output power 300 watts R.M.S. into 4 ohms, Frequency Response 1Hz – 100KHz – 3dB, Damping Factor >300, Slew Rate 60V/uS, T.H.D. Typical 0.0008%, Input Sensitivity 500mV, S.N.R. – 130dB. Size 330 x 175 x 100mm.
PRICE £79.99 + £4.50 P&P.

NOTE:— MOS-FET MODULES ARE AVAILABLE IN TWO VERSIONS, STANDARD — INPUT SENS. 500mV BAND WIDTH 100KHz, PEC (PROFESSIONAL EQUIPMENT COMPATABLE) — INPUT SENS. 775mV, BAND WIDTH 50KHz, ORDER STANDARD OR PEC



Vu METER Compatible with our four amplifiers detailed above. A very accurate visual display employing 11 L.E.D. diodes (7 green, 4 red) plus an additional on/off indicator. Sophisticated logic control circuits for very fast rise and decay times. Tough moulded plastic case, with tinted acrylic front. Size 84 x 27 x 45mm.
PRICE £8.50 + 50p P&P.

LOUDSPEAKERS



LARGE SELECTION OF SPECIALIST LOUDSPEAKERS AVAILABLE, INCLUDING CABINET FITTINGS, SPEAKER GRILLES, CROSS-OVERS AND HIGH POWER, HIGH FREQUENCY BULLETS AND HORNS, LARGE S.A.E. (30p STAMPED) FOR COMPLETE LIST.

McKENZIE:— INSTRUMENTS, P.A., DISCO, ETC.

ALL MCKENZIE UNITS 8 OHMS IMPEDENCE

- 8" 100 WATT C8100GPM GEN. PURPOSE, LEAD GUITAR, EXCELLENT MID. DISCO. RES, FREQ. 80Hz. FREQ. RESP. TO 14KHz SENS. 99dB **PRICE £28.59 + £2.00 P&P.**
- 10" 100 WATT C10100GP GUITAR, VOICE, ORGAN, KEYBOARD, DISCO, EXCELLENT MID. RES, FREQ. 70Hz. FREQ. RESP. TO 6KHz SENS. 100dB **PRICE £34.70 + £2.50 P&P.**
- 10" 200 WATT C10200GP GUITAR, KEYBOARD, DISCO, EXCELLENT HIGH POWER MID. RES, FREQ. 45Hz. FREQ. RESP. TO 7KHz SENS. 103dB **PRICE £47.48 + £2.50 P&P.**
- 12" 100 WATT C12100GP HIGH POWER GEN. PURPOSE, LEAD GUITAR, DISCO. RES, FREQ. 45Hz. FREQ. RESP. TO 7KHz SENS. 98dB **PRICE £36.66 + £3.50 P&P.**
- 12" 100 WATT C12100TC TWIN CONE) HIGH POWER WIDE RESPONSE, P.A., VOICE, DISCO. RES, FREQ. 45Hz. FREQ. RESP. TO 14KHz SENS. 100dB **PRICE £37.63 + £3.50 P&P.**
- 12" 200 WATT C12200B HIGH POWER BASS, KEYBOARDS, DISCO, P.A. RES, FREQ. 40Hz. FREQ. RESP. TO 7KHz SENS. 100dB **PRICE £64.17 + £3.50 P&P.**
- 12" 300 WATT C12300GP HIGH POWER BASS LEAD GUITAR, KEYBOARDS, DISCO, ETC. RES, FREQ. 45Hz. FREQ. RESP. TO 5KHz SENS. 100dB **PRICE £85.79 + £3.50 P&P.**
- 15" 100 WATT C15100BS BASS GUITAR, LOW FREQUENCY, P.A., DISCO. RES, FREQ. 40Hz. FREQ. RESP. TO 5KHz SENS. 98dB **PRICE £53.70 + £4.00 P&P.**
- 15" 200 WATT C15200BS VERY HIGH POWER BASS. RES, FREQ. 40Hz. FREQ. RESP. TO 4KHz SENS. 99dB **PRICE £73.26 + £4.00 P&P.**
- 15" 250 WATT C15250BS VERY HIGH POWER BASS. RES, FREQ. 40Hz. FREQ. RESP. TO 4KHz SENS. 99dB **PRICE £80.53 + £4.50 P&P.**
- 15" 400 WATT C15400BS VERY HIGH POWER, LOW FREQUENCY BASS. RES, FREQ. 40Hz. FREQ. RESP. TO 4KHz SENS. 102dB **PRICE £94.12 + £4.50 P&P.**
- 18" 400 WATT C18400BS EXTREMELY HIGH POWER, LOW FREQUENCY BASS. RES, FREQ. 27Hz. FREQ. RESP. TO 3KHz SENS. 99dB **PRICE £167.85 + £5.00 P&P.**

EARBENDERS:— HI-FI, STUDIO, IN-CAR, ETC.

- ALL EARBENDER UNITS 8 OHMS EXCEPT EB8-50 DUAL 4 AND 8 OHM BASS, SINGLE CONE, HIGH COMPLIANCE, ROLLED FOAM SURROUND**
- 8" 50 WATT EB8-50 DUAL IMPEDENCE, TAPPED 4/8 OHM BASS, HI-FI, IN-CAR. RES, FREQ. 40Hz. FREQ. RESP. TO 7KHz SENS. 97dB **PRICE £8.90 + £2.00 P&P.**
- 10" 50 WATT EB10-50 DUAL IMPEDENCE, TAPPED 4/8 OHM BASS, HI-FI, IN-CAR. RES, FREQ. 40Hz. FREQ. RESP. TO 5KHz SENS. 99dB **PRICE £12.00 + £2.50 P&P.**
- 10" 100 WATT EB10-100 BASS, HI-FI, STUDIO. RES, FREQ. 35Hz. FREQ. RESP. TO 3KHz SENS. 96dB **PRICE £27.50 + £3.50 P&P.**
- 12" 60 WATT EB12-60 BASS, HI-FI, STUDIO. RES, FREQ. 28Hz. FREQ. RESP. TO 3KHz SENS. 92dB **PRICE £21.00 + £3.00 P&P.**
- 12" 100 WATT EB12-100 BASS, STUDIO, HI-FI, EXCELLENT DISCO. RES, FREQ. 26Hz. FREQ. RESP. TO 3KHz SENS. 93dB **PRICE £32.00 + £3.50 P&P.**
- FULL RANGE TWIN CONE, HIGH COMPLIANCE, ROLLED SURROUND**
- 5 1/2" 60 WATT EB5-60TC (TWIN CONE) HI-FI, MULTI-ARRAY DISCO ETC. RES, FREQ. 63Hz. FREQ. RESP. TO 20KHz SENS. 92dB **PRICE £9.99 + £1.50 P&P.**
- 6 1/2" 60 WATT EB6-60TC (TWIN CONE) HI-FI, MULTI-ARRAY DISCO ETC. RES, FREQ. 38Hz. FREQ. RESP. TO 20KHz SENS. 94dB **PRICE £10.99 + £1.50 P&P.**
- 8" 60 WATT EB8-60TC (TWIN CONE) HI-FI, MULTI-ARRAY DISCO ETC. RES, FREQ. 40Hz. FREQ. RESP. TO 18KHz SENS. 95dB **PRICE £12.99 + £1.50 P&P.**
- 10" 60 WATT EB10-60TC (TWIN CONE) HI-FI, MULTI-ARRAY DISCO ETC. RES, FREQ. 35Hz. FREQ. RESP. TO 12KHz SENS. 86dB **PRICE £16.49 + £2.00 P&P.**

TRANSMITTER HOBBY KITS

PROVEN TRANSMITTER DESIGNS INCLUDING GLASS FIBRE PRINTED CIRCUIT BOARD AND HIGH QUALITY COMPONENTS COMPLETE WITH CIRCUIT AND INSTRUCTIONS

3W FM TRANSMITTER 80-108MHz, VARICAP CONTROLLED PROFESSIONAL PERFORMANCE, RANGE UP TO 3 MILES, SIZE 38 x 123mm, SUPPLY 12V @ 0.5AMP, **PRICE £14.49 + £1.00 P&P**

FM MICRO TRANSMITTER (BUG) 100-108MHz VARICAP TUNED COMPLETE WITH VERY SENS FET MIC, RANGE 100-300m, SIZE 56 x 46mm, SUPPLY 9V BATT, **PRICE £8.82 + £1.00 P&P**



3 watt FM Transmitter

POSTAL CHARGES PER ORDER £1.00 MINIMUM. OFFICIAL ORDERS WELCOME FROM SCHOOLS, COLLEGES, GOVT. BODIES, ETC. PRICES INCLUSIVE OF V.A.T. SALES COUNTER. VISA ACCESS ACCEPTED BY POST, PHONE OR FAX.



* PRICES INCLUDE V.A.T. * PROMPT DELIVERIES * FRIENDLY SERVICE * LARGE S.A.E., 30p STAMPED FOR CURRENT LIST.

OMP VARISPEED TURNTABLE CHASSIS



* MANUAL ARM * STEEL CHASSIS * ELECTRONIC SPEED CONTROL 33 & 45 * WARI PITCH CONTROL * HIGH TORQUE SERVO DRIVEN DC MOTOR * TRANSIST SCREWS * 12" DIE CAST PLATTER * NEON STROBE * CALIBRATED BAL WEIGHT * REMOVABLE HEAD SHELL * 1/2" CARTRIDGE FIXINGS * CUE LEVER * POWER 220-240V 50/60Hz * 390x305mm * SUPPLIED WITH MOUNTING CUT-OUT TEMPLATE.
PRICE £59.99 + £3.50 P&P.

OPTIONAL MAGNETIC CARTRIDGES

STANTON AL500
PRICE £16.99 + 50p P&P

GOLDRING G850
PRICE £6.99 + 50p P&P

OMP MOS-FET POWER AMPLIFIERS, HIGH POWER, TWO CHANNEL 19 INCH RACK

THOUSANDS PURCHASED BY PROFESSIONAL USERS



NEW MXF SERIES OF POWER AMPLIFIERS

THREE MODELS:— **MXF200 (100w + 100w)**
MXF400 (200w + 200w) **MXF600 (300w + 300w)**

All power ratings R.M.S. into 4 ohms.

FEATURES: * Independent power supplies with two Toroidal Transformers * Twin L.E.D. Vu meters * Rotary interded level controls * illuminated on off switch * XLR connectors * Standard 775mV inputs * Open and short circuit proof * Latest Mos-Fets for stress free power delivery into virtually any load * High slew rate * Very low distortion * Aluminium cases * MXF600 Fan Cooled with D.C. Loudspeaker and Thermal Protection.

USED THE WORLD OVER IN CLUBS, PUBS, CINEMAS, DISCOS ETC.

SIZES:— MXF 200 W19" x H3 1/2" (2U) x D11"
MXF 400 W19" x H5 1/4" (3U) x D12"
MXF 600 W19" x H5 1/4" (3U) x D13"

MXF200 £171.35

MXF400 £228.85

MXF600 £322.00

SECURICOR DELIVERY £12.00 EACH

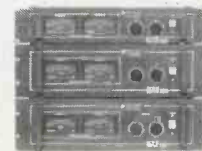

OMP LINNET LOUDSPEAKERS

THE VERY BEST IN QUALITY AND VALUE



MADE ESPECIALLY TO SUIT TODAY'S NEED FOR COMPACTNESS WITH HIGH OUTPUT SOUND LEVELS. FINISHED IN HARDWEARING BLACK VYNIDE WITH PROTECTIVE CORNERS, GRILLE AND CARRYING HANDLE. INCORPORATES 12" DRIVER PLUS HIGH FREQ. HORN FOR FULL FREQ. RANGE. 45Hz-20KHz BOTH MODELS 8 OHM, SIZE H18" x W15" x D12"

CHOICE OF TWO MODELS

POWER RATINGS QUOTED IN WATTS RMS FOR EACH CABINET

OMP 12-100 (100W 100dB) PRICE £159.99 PER PAIR

OMP 12-200 (200W 102dB) PRICE £209.99 PER PAIR

SECURICOR DEL.— £12.00 PER PAIR

OMP SLIDE DIMMER 1K WATT & 2.5K WATT

CONTROLS LOADS UP TO 1KW & 2.5KW SUITABLE FOR RESISTIVE AND INDUCTIVE LOADS BLACK ANODISED CASE. READILY FLUSH MOUNTED THROUGH PANEL/CABINET CUT-OUTS. ADVANCED FEATURES INCLUDE:—

- * FULL 65mm SLIDE TRAVEL
- * NEON MONITOR INDICATOR
- * FLASH OVERRIDE BUTTON
- * HIGH & LOW LEVEL PRESETS
- * FULLY SUPPRESSED TO BS 600

SIZES:— 1KW H128xW40xD55mm
2.5KW H128xW76xD79mm

PRICES:— 1K WATT £15.99
2.5K WATT £24.99 + 60p P&P

PIEZO ELECTRIC TWEETERS—MOTOROLA

PIEZO ELECTRIC TWEETERS — MOTOROLA

Join the Piezo revolution. The low dynamic mass (no voice coil) of a Piezo tweeter produces an improved transient response with a lower distortion level than ordinary dynamic tweeters. As a crossover is not required these units can be added to existing speaker systems of up to 100 watts (more if 2 put in series). **FREE EXPLANATORY LEAFLETS SUPPLIED WITH EACH TWEETER.**

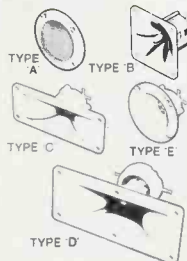

TYPE 'A' (KSN2036A) 3" round with protective wire mesh, ideal for bookshelf and medium sized Hi-Fi speakers. Price £4.90 each + 50p P&P.

TYPE 'B' (KSN1005A) 3 1/2" super horn. For general purpose speakers, disco and P.A. systems etc. Price £5.00 each + 50p P&P.

TYPE 'C' (KSN6016A) 2" x 5" wide dispersion horn. For quality Hi-Fi systems and quality discos etc. Price £6.99 each + 50p P&P.

TYPE 'D' (KSN1025A) 2" x 6" wide dispersion horn. Upper frequency response retained extending down to mid range (2KHz). Suitable for high quality Hi-Fi systems and quality discos. Price £9.99 each + 50p P&P.

TYPE 'E' (KSN1038A) 3 3/4" horn tweeter with attractive silver finish trim. Suitable for Hi-Fi monitor systems etc. Price £5.99 each + 50p P&P.

LEVEL CONTROL Combines on a recessed mounting plate, level control and cabinet input jack socket. 85x85mm. Price £3.99 + 50p P&P.

STEREO DISCO MIXER

STEREO DISCO MIXER with 2 x 5 band L & R graphic equalisers and twin 10 segment L.E.D. Vu Meters. Many outstanding features 5 inputs with individual faders providing a useful combination of the following:—
3 Turntables (Mag), 3 Mics, 4 Line including CD plus Mic with talk over switch Headphone Monitor. Pan Pot L & R, Master Output controls. Output 775mV. Size 360x280x90mm. Supply 220-240V.
Price £134.99 — £4.00 P&P



B. K. ELECTRONICS Dept PE

UNIT 5, COMET WAY, SOUTHEND-ON-SEA, ESSEX. SS2 6TR
TEL: 0702-527572 FAX: 0702-420243

Thaur
288

OVER 580 PAGES WITH HUNDREDS OF NEW PRODUCTS AT SUPER LOW PRICES THE NEW MAPLIN CATALOGUE - WORLDS APART 1990 BUYER'S GUIDE TO ELECTRONIC COMPONENTS SEND FOR YOUR COPY TODAY



PE 90

ORDER YOUR COPY OF THE NEW MAPLIN CATALOGUE ON SALE NOW

Pick up a copy from any W.H. Smith for just £2.25 or post this coupon now to receive your copy for just £2.25 + 50p p & p. If you live outside the UK, send £4 or 17 International Reply Coupons. Enclose £2.75

Name: _____
Address: _____

Post Code _____

Send to Maplin Electronics, P.O. Box 9, Rayleigh, Essex, SS6 8LR

AVAILABLE FROM 10th NOVEMBER 1989 IN ALL W.H. SMITH STORES