

PRACTICAL

MAY 1989 • £1.25

ELECTRONICS

SCIENCE & TECHNOLOGY

KIRLIAN CAMERA

Build and investigate
force-field phenomena

**8 EXTRA
PAGES
IN OUR
NEW LOOK
ISSUE!**

HOME AUTOMATION

From smart cards
to teleshopping

DIGITAL MULTIMETERS

Know the
essential
facts

NEW QUICK-CHIP SERIES

Simple circuits
and practical
projects

**TELL US
WHAT!**

Help us plan
the 1990s

**WIN
TELEPOINT PERSONAL
TELEPHONES**



MICRONTA[®]

MULTIMETERS ONLY FROM TANDY[®]

Benchtop Digital LCD Multimeter - £79.95

- Manual Or Autoranging Facility
- Measures AC/DC Volts, Current And Resistance

22-195

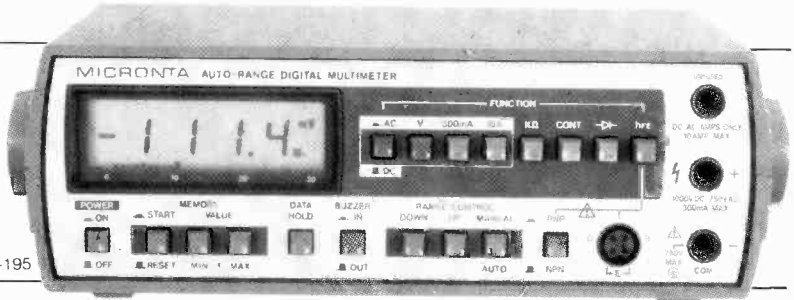

Pocket Autoranging Multimeter - £19.95

- Measures To 400 Volts AC/DC, Resistance To 2 Megohms
- Includes Miniprobe And Folding Case

22-171

Pocket Multimeter - £8.95

- 2K Ohms/Volt DC Sensitivity
- Measures To 1000V AC/DC, DC Current To 150mA And Resistance To 100,000 Ohms

22-7212



Probe-Style Autoranging Multimeter - £29.95

- Fully Automatic Range And Polarity
- Ideal For Testing In Confined Spaces
- Data Hold Freeze Display

22-165



Tandy[®]

For The Best In High Quality Electronics

Over 450 Tandy Stores And Dealerships Nationwide.
See Yellow Pages For Address Of Store Nearest You.

InterTAN U.K. Ltd., Tandy Centre, Leamore Lane,
Walsall, West Midlands. WS2 7PS Tel: 0922 710000



Page 4 ▲

▼Page 12

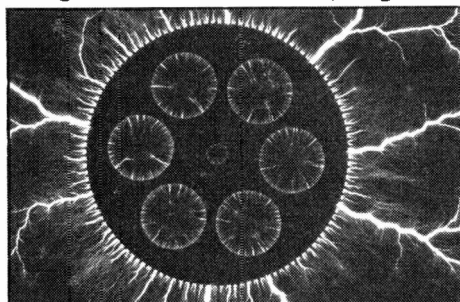

Page 19 ▼

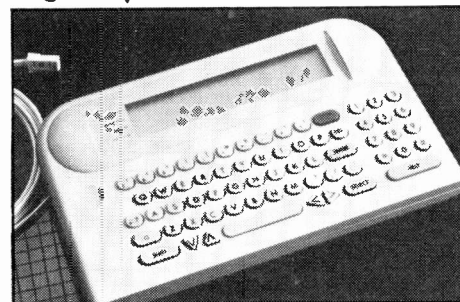

NEXT MONTH

Musicians need never be barred for lateness again - there's a high precision metronome to build. May the sun shine into your wallet when you build the solar heating controller. And discover that Britains can rule the waves even better now that microchips tune into Neptune - we've an in-depth report on leisure marine electronics. All this, and more in the June 1989 issue. Order it from your newsagent, take out a subscription, queue on our doorstep, what ever you do:

- ★ DON'T MISS OUR JUNE 1989 ISSUE
- ★ ON SALE FROM FRIDAY MAY 5TH
- ★ AND STILL AT ONLY £1.25
- ★ YOU CAN'T BEAT OUR VALUE
- ★ OR OUR NEW GOOD LOOKS!

PRACTICAL ELECTRONICS

VOL 25 NO 5

MAY 1989

CONTENTS

COMPETITION

WIN A FORUM TELEPOINT PHONE!64
Answer seven simple questions and you could win one of the latest hi-tech portable telephones - worth around £170 each!

READER SURVEY

TELL US WHAT'S WHAT!37
Help us decide how PE should look for the 1990s. You could win £100, and all entrants will receive valuable vouchers.

CONSTRUCTIONAL PROJECTS

- KIRLIAN CAMERA by Don Phillips**12
Build an experimental supercharged aura detector and you could reap more than fringe benefits.
- DIGITAL ELECTRONICS by Owen Bishop**41
More computer logic and practical ways to apply it systematically.
- EASI-BUILD CIRCUIT by John Becker**51
Starting a new series of useful simple circuits you can build in your idle moments. This month it's a single chip phone monitor.

SPECIAL FEATURES

- HOME AUTOMATION - PART TWO by John Becker**19
How Smart Cards, interactive video and computer-linked phones offer the rainbow bridge to teleshopping, telebanking and total home control.
- HI-TECH TIMING - PART TWO by Anthony H. Smith**32
Marking time from rubidium resonators to caesium oscillators, and the clock at Rugby.
- STATE SIDE - WCES 89 by Wayne Green**48
Can it be true that apathy is setting in on the American consumer electronics scene?
- DIGITAL MULTIMETERS by Samuel Dick**27
What to consider when choosing digital multimeters, and discussing their advantages over analogue meters.
- TELEPOINTING THE WAY by Michael Strassen**56
The first of the new Telepoint personal telephones has been launched. Read the review on the Forum, then enter our competition to win one!

REGULAR FEATURES

- EDITORIAL by John Becker - Future indicative**9
- LEADING EDGE by Barry Fox - Behavioural morality**8
- SPACEWATCH by Dr Patrick Moore - Exploring Phobos**46
- INDUSTRY NOTEBOOK by Tom Ivall - Musical chairs**65

PRODUCT FEATURES

- READERS' LETTERS - and a few answers**54
- MARKETPLACE - what's new, where and when**4
- ARMCHAIR BOOKSHOP - lots more titles in our book list**66
- PCB SERVICE - professional PCBs for PE Projects**68
- BAZAAR - Readers' FREE advertising service**69
- ADVERTISERS' INDEX - locating favourite stockists**70

PE TAKES TECHNOLOGY FURTHER - BE PART OF IT!

VIGLEN'S VIGOROUS PCS

Viglen have sent us details of the five IBM compatible PCs in their VIG range, all of which have been designed to provide fast, flexible and reliable desk top processing.

The range commences with the VIG I, which is the fastest IBM XT compatible currently on the market. Two versions are available with 12 MHz and 15 MHz switchable speeds, each in various configurations. Both versions offer 640 KB of ram as standard and can house up to 1 MB on the motherboard.

The VIG II Elite is an IBM AT compatible, and is based upon the very latest NEAT (new enhanced AT) technology chip. It is available at 12 MHz and 16MHz switchable speeds and has the flexibility for further expansion. The memory can be set up as extended or expanded using the very latest EMS LIM Version 4. The motherboard allows up to 8MB of ram, thus making it an ideal computer for OS/2.

At the top of the range is the VIG III Cache, which is one of the highest performance 386 machines on the market. It offers 2 MB of memory as standard, and this may be expanded to 16 MB by the addition of a memory expansion card. This 386 features 64K of fast access static ram giving it 0 wait state. This makes the 20 MHz speed equivalent



to 30 MHz Landmark speed.

A recent addition to the range is the VIG II portable. It may be switched from 8 MHz to 12 MHz and is supplied with 1MB of ram as standard, and, like the VIG II Elite, the motherboard can be expanded to 8MB, and benefits from the same advanced features. A VIG Laptop will soon be available.

The range of Viglen computers can be supplied with both 5.25" and 3.5" disk drives as an optional extra.

The PCs are able to run all the best known software packages and are fully compatible with the equivalent IBM PC/XT/AT models. As standard, each computer comes complete with MS.DOS 3.30 and GW Basic. Viglen, however, are one of the few UK companies now supplying MS.DOS version 4.

For further information, please contact Diran Kazandjian at Viglen, Unit 7, Trumpers Way, Hanwell, London W7 2QJ. Tel: 01-574 5126.

INDICATING HARRIS PANEL METERS

Harris have a wide range of analogue and digital panel meters available to suit all applications. Analogue models feature wide angle, easy viewing and shadow free dials. Digital models have 3³/₄ digits with 3999 count, bright orange leds and conform to DIN sizes.

Moving coil panel meters come in four basic formats. All have a full scale accuracy of 2.5% and operate as microammeters, milliammeters, ammeters or voltmeters for both ac and dc. Bench stand meters are available, and specials to suit individual requirements can be supplied on request and are just part of the comprehensive service offered.

Sixteen basic digital models are available for alternating and direct current and voltage. Options to the basic range enable these high quality digital meters to directly replace analogue models in existing equipment. Basic dc voltage accuracy is 0.2% with a best resolution of 0.1mV. Maximum voltages are 1000V ac and 400V dc while maximum current is 1000A direct and 100A for alternating.

Literature showing the wide range of sizes, scale lengths and mounting details is freely available from Harris Electronics (London) Ltd, Building 3, GEC Estate, East Lane, Wembley, Middx, HA9 7PT. Tel: 01-908 3355.

CATALOGUE

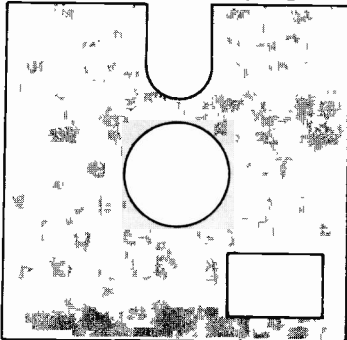

DATABASE

We have recently received the following literature:

Livingstone Hire's 1989 rental catalogue is an ideal source of information for those looking to use an item of test equipment with out actually owning it. Their 124-page colour catalogue shows an enormous range of products, covering general purpose test equipment, logic analysers, microprocessor development systems, prom programmers and computers. They have several offices in the UK, and phoning on the FREE helpline 0800 886000 will locate your nearest branch.

Antex have sent another leaflet on precision soldering and some of their related products. It's a useful short guide to what to look out for when choosing soldering equipment. Antex Electronics, Mayflower House, Armada Way, Plymouth, Devon. Tel: 0752 667377.

Ceka Works tell us they have their new price list available and that it covers their entire product range. It's a pity they didn't tell us what's in the range! Why not ask for the list any way, it could be interesting. Ceka Works Ltd., Pwllheli, Gwynedd. Tel: 0758 701070.

Unitel's complete resistive products range is covered in their new 60 page illustrated catalogue. It also covers precision and panel controls and trimmers, plus rf inductors and filters. It's free of charge and full technical support is provided on the ranges. They've got a new 56 page capacitor catalogue as well. Unitel Ltd, Fishers Green Road, Stevenage, Herts. SG1 2PT. Tel: 0438 312393.

The IR Group catalogue offers a complete guide to instrument sales. Its 110 pages feature oscilloscopes, signal sources, multimeters, counter timers, psus, logic analysers, etc. Many of the products are also available for renting or leasing. IR Group, Dorcan House, Meadfield Road, Langley, Berks, SL3 8AL. Tel: 0753 580000.

TK Electronics, one of our many respected advertisers, have sent a leaflet describing three of their latest kits, a door chime, a whistle switch, and a sound generator. The kits are only £3.90 each and are ideal beginner's material. Ask for details on these and other products from TK Electronics, 13 Boston Road, London W7 3SJ. Tel: 01 579 9794.



3 1/2-DIGIT, HANDHELD MULTIMETER

A handheld, digital multimeter which costs only £39.95, is now available from Global Specialities.

The meter features a 3 1/2-digit liquid crystal display, and has six functions.

The ranges are 200mV to 1000V dc, 200mV to 750V ac, 200µA, to 20A dc and ac, 20 ohm to 20 Mohm and, finally, pnp/npn transistor testing, measuring hFE from 0 to 1000

at an lb of 10µA, plus diode test.

The Model 6022A is powered by a 9V alkaline battery providing in excess of 150 hours continuous use. The meter is supplied with test leads, and a carrying case is available as an option.

Contact: Global Specialities, 2nd Floor, 2-10 St. Johns Street, Bedford, MK42 0DH. Tel: 0234 217856.

KITTING-UP SATELLITES

You may recall that a Connexions satellite tv receiver was one of our competition prizes last year. The company have now introduced a satellite tv installation kit, principally aimed at professional installers.

The installation kit comprises: antenna setting meter, inclinometer, compass, crimp tool, multimeter, inline amplifier, insertion tool, 2 way splitter, F type connectors, F type coupler, weather boots, F to N adaptor, N to F adaptor.

Of special interest is the insertion tool, exclusive to Connexions - for quick and easy application of F type connectors to RG6 coaxial cable. All components are available separately and can be purchased from all Connexions distributors. The kit

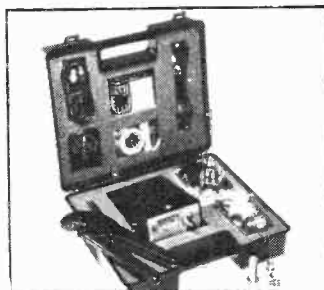

comes in an attractive durable polypropylene case and is available at a trade price of £129.95 plus vat.

For further information: Connexions (UK) Plc, Unit 3, South Mimms Distribution Centre, Huggins Lane, Welham Green, Herts, AL9 7LE. Tel: 07072 72091.

If you are organising any event to do with electronics, big or small, drop us a line – we shall be glad to include it here.

Please note: Some events listed here may be trade or restricted category only. Also, we cannot guarantee information accuracy, so check details with the organisers before setting out.

Apr. 11-13 Portable Computing and Data Capture 89. Conference and exhibition. Rivermead, Reading. RMDP. 0273 722687.

Apr. 25-27. British Electronics Week. Olympia. 0799 26699.

May 8-10. Eurobus 89 – German Conference. Munich Sheraton Hotel, Munich. 01-940 4625.

May 9-12. Automan. Robotics and automation exhibition. NEC, Birmingham. 01-891 5051.

May 31-Jun 2. Computer Training Show. Olympia 2, London. 01-486 1951.

Jun. 5-9. Lasers, Optoelectronics, Microwaves. 9th International Trade Fair and Congress. Munich Fair Centre. 01-948 5166.

Jun. 6-8. Computer North. G-Mex, Manchester. 061 832 4242.

Jun. 13-15. Software Tools 89. Wembley Conference Centre. 01-868 4466.

Jun. 14-15. Instrumentation Scotland. The Forum, Livingstone. 0822 614671.

Jul. 10-13. EWEC '89. European wind energy conference and exhibition. Scottish Conference and Exhibition Centre, Glasgow. No reference tel. known.

Jul. 24-26. Vacuum Microelectronics – 2nd International Conference. Bath. Contact Dr R.A. Lee. GEC Hirst Research Centre, Wembley, Middx, HA9 7PP. 01-908 9000.

Aug. 25-Sep 3. International Audio and Video Fair. Berlin. 01-408 0111.

Sep. 4-6. Eurobus 89 – UK Conference. Novotel Hotel, London. 01-940 4625.

Sep. 12-15. EPOS 89. The World's largest exhibition of retail information systems. Alexandra Palace, London. RMDP. 0273 722687.

Oct. 16-20. Systems, Computers and Communications. 11th International Trade Fair and Congress. Munich Trade Fair Centre. 01-948 5166.

Oct. 24-26. Sensors and Systems – International Transducer Exhibition and Conference. Wembley Conference Centre. 0822 614671.

Nov. 7-11. Productronica. 8th International Trade Fair for Electronics Production. Munich Trade Fair Centre. 01-948 5166.

BTEC CONTINUING EDUCATION CERTIFICATE COURSES. Starting dates Jan11 and Apr 26 – each course 2 days per week Wed/Fri for 13 weeks. London Electronics College, 20 Penywern Road, London SW5 9SU. 01-373 8721.

NEWS

SKYPHONE TAKES OFF!

British Telecom's Skyphone, the world's first satellite telephone communications system for airline passengers, started trial operations in mid-February on an intercontinental British Airways Boeing 747. Skyphone will allow passengers to make in-flight calls to anywhere in the world.

Anthony Booth, Managing Director of BT International said, 'Skyphone is another excellent addition to BT's wide range of international services, and its successful development illustrates our intention to provide customers, wherever they may be, with rapid and reliable communications'.

Calls are transmitted via the Inmarsat satellite system and then routed into BT's worldwide network. In conjunction with partners in Norway and Singapore, BT is due to complete the worldwide Skyphone network by the end of 1989. The system has been developed and tested under a collaborative agreement between British Telecom, Rascal and British Airways.

The pioneering technique developed by scientists at British Telecom's Research Laboratories for converting telephone speech to digital form has been adopted as the world standard by the Airlines

Electrical Engineering Committee. It will be used by pilots when they talk to air traffic controllers as well as by passengers.

BT's speech coder was adjudged the best in an international competition, in which more than 20 different designs from all over the world were considered. The four best - from the USA and Japan as well as the UK - were comprehensively tested under simulated operating conditions.

Tests were carried out by telecommunications network operators in the three countries. In addition, the Civil Aviation Authority conducted extensive tests with pilots from international airlines. The BT design emerged as the clear winner in both types of tests.

The coder converts the analogue waves of telephone speech into a series of digital impulses. These are generated at a rate of 9,600 per second, the lowest rate so far used in public civil telecommunications. It compares to the 64 kbit/s used as standard for speech encoding in modern digital networks.

Operation at these low rates reduces the size and weight of the airborne encoding equipment, while at the same time maintaining high speech quality.

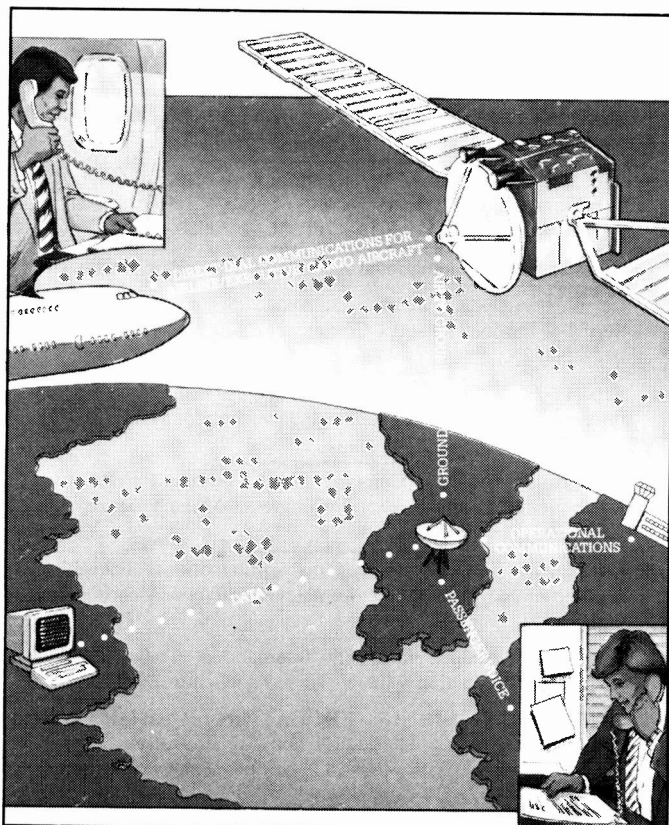

NATIONAL COMPONENT CLUB

SPECIAL OFFERS * SPECIAL OFFERS

SCANNER KIT(T)

A complete, six channel LED chaser kit for less than a fiver! The kit comes complete with all components, including PCB and instructions simple enough for even a complete novice. Works from 6-15vdc.

Only £4

MAINS POWER SUPPLY FOR ABOVE £1

* SPECIAL OFFER PACKS *

100 ASSORTED CAPACITORS £1

30 ASSORTED TRANSISTORS £1

25 ELECTROLYTIC CAPACITORS £1

12 LED's (5mm red or green) £1

5 555 TIMER IC's £1

5 741 OP-AMPS £1

FREE MYSTERY PACK WITH ALL ORDERS OVER £6

Please add £1 P&P, but do not add VAT. P.O. or cheque to: NATIONAL COMPONENT CLUB, DEPT PE, BAILEY HILL, CASTLE CARY, SOMERSET BA7 7AD

We now accept Access - phone (0963) 51171

* FREE CLUB MEMBERSHIP *

Just phone above number or write for details

Interak 1 BUILD YOUR OWN COMPUTER



INTERAK can be commenced with the minimum of outlay. Bare boards from £10.95, beg borrow or steal the components, or buy from us - all parts available separately. No special or custom chips (ie PALs, ULAs, ASICs etc) used - no secrets.

Go as fast or as slowly as your funds and enthusiasm permit

Made for those who must know what goes inside. Full circuit diagrams and descriptions are provided. And honestly, can you really use a computer effectively if you don't know what's inside and nobody will tell you?

Solid engineering construction - something to be proud of. 19" 3U rack mounting, plug in circuit boards and modular construction keeps obsolescence at bay.

Flourishing Independent Users Group, and newsletter. Hundreds of programs on disk at little or no cost from the Users Group.

Program in machine code (Assembler), Basic, "C", Forth, etc Database, Word Processing, Scientific applications.

Cassette tape operation or disk (up to 4 drives, 1 Megabyte 3.5" available from us, but you can add 3", 5.25", 8" if you want). Disk operating system CP/M Plus.

64K RAM, Z80 based at present with potential for expansion to a 16 Megabytes address space and Zilog's latest Z80280 in the future.

Needs no specialised knowledge to construct, and we will happily get you out of a jam if you get into one.

Availability of personal and individual after sales service, impossible to obtain from large companies, who are only after your money.

Security of supply - from Greenbank Electronics, established in 1970.

Greenbank

For more details write or phone us:
Greenbank Electronics, Dept (EO5P), 460 New Chester Road, Rock Ferry, Birkenhead, Merseyside. L42 2AE. Tel: 051-645

POWER CONDITIONER

FEATURED IN ETI
JANUARY 1988

The ultimate mains purifier. Intended mainly for lowering the noise floor and improving the analytical qualities of top flight audio equipment.

The massive filter section contains thirteen capacitors and two current balanced inductors, together with a bank of six VDRs to remove every last trace of impulsive and RF interference. A ten LED logarithmic display gives a second by second indication of the amount of interference removed. Our approved parts set consists of case, PCB, all components (including high permeability toroidal cores, ICs, transistors, class X and Y suppression capacitors, VDRs etc.) and full instructions.

PARTS SET £29.80 + VAT

A low cost (but high performance) mains conditioner is also available.
MAINS CONDITIONER PARTS SET £5.40 + VAT
RUGGED PLASTIC CASE £1.80 + VAT

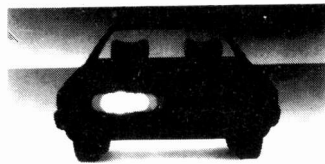
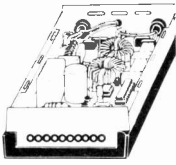

KNIGHT RAIDER

FEATURED IN ETI JULY 1987

The ultimate in lighting effects for your Lamborghini, Maserati, BMW (or any other car, for that matter). Picture this: eight powerful lights in line along the front and eight along the rear. You flick a switch on the dashboard control box and a point of light moves lazily from left to right leaving a comet's tail behind it. Flip the switch again and the point of light becomes a bar, bouncing backwards and forwards along the row. Press again and try one of the other six patterns. An LED display on the control box lets you see what the main lights are doing.

The Knight Raider can be fitted to any car (it makes an excellent fog light!) or with low powered bulbs it can turn any child's pedal car or bicycle into a spectacular TV-age toy!

The parts set consists of box, PCB and components for control PCB and components for sequence board and full instructions.
Lamps not included.

PARTS SET £24.80 + VAT

RAINY DAY PROJECTS



All can be built in an afternoon!

- JUMPIN' JACK FLASH (ETI March 1988)
Spectacular rock, stage and disco lighting effect! £6.90 + VAT
- CREDIT CARD CASINO (ETI March 1987)
The wicked pocket gambling machine £5.90 + VAT
- MAINS CONTROLLER (ETI January 1987)
Isolated logic to mains interface £6.20 + VAT
- MATCHBOX AMPLIFIERS (ETI April 1986)
Listen 50W of Hi-Fi power from an amp small enough to fit in a matchbox!
Matchbox Amplifier (20W) £6.50 + VAT
Matchbox Bridge Amplifier (50W) £8.90 + VAT
L165V Power Amplifier IC with data and circuits £3.90 + VAT
- TACHO/DWELL METER (ETI January 1987)
Turn your Metro into a Porsche! £16.40 + VAT
- HI-FI POWER METER (ETI May 1987)
Measures Hi-Fi output power up to 100W - includes PCB components, meters £3.90 + VAT
Mono power meter £7.20 + VAT

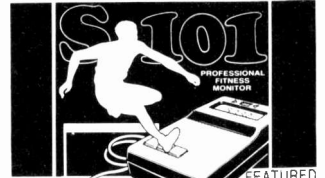

FEATURED IN ETI
AUGUST 1988

There's nothing quite so encouraging as having a quantifiable result to show for your training efforts. If you are not particularly fit, your resting heart rate will be around 80 beats per minute. As your ongoing aerobic or sport strengthens your heart, the rate will drop dramatically - possibly to 60 beats or less. With the S101, you can watch your progress day by day.

Breathing is important too. How efficiently do you take up oxygen? How quickly do you recover from oxygen debt after strenuous activity? The S101 will let you know.

The approved parts set consists of case, 3 printed circuit boards, all components (including 741 ICs, quartz crystal, 75 transistors, resistors, diodes and capacitors), LCD switches, jugs, sockets, electrodes and full instructions for construction and use.

PARTS SET £33.80 + VAT

Some parts are available separately - please send SAE for lists, or SAE + £1 for lists, circuit and construction details and further information (free with parts set).



THE DREAM MACHINE

FEATURED IN ETI
DECEMBER 1987



Adjust the controls to suit your mood and let the gentle relaxing sound drift over you. At first you might hear soft rain, sea surf, or the wind through distant trees. Almost hypnotic, the sound draws you irresistibly into a peaceful, refreshing sleep.

For many, the thought of waking refreshed and alert from perhaps the first truly restful sleep in years is exciting enough in itself. For more adventurous souls there are strange and mysterious dream experiences waiting. Take lucid dreams for instance. Imagine being in control of your dreams and able to change them at will to act out your wishes and fantasies. With the Dream Machine it's easy!

The approved parts set consists of PCB, all components, controls, loudspeaker, knobs, lamp, fuseholders, fuse, mains power supply, prestige case and full instructions.

PARTS SET £19.80 + VAT

Ben Sweetland's best seller GROW RICH WHILE YOU SLEEP is now in stock. £2.95 (NO VAT)

TV BOOSTER

Good TV pictures from poor aerials is what this project is all about. Keith Brindley's Aerial Booster gives a massive 23dB gain to ensure good viewing for campers and caravaners, from motor aerials, or wherever a properly positioned high-gain antenna is not practical.

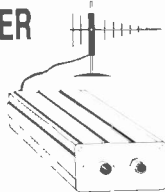

Based on the OM335 hybrid amplifier, the booster has specifications to rival the best: wideband operation from 10MHz to 1.4 GHz, mid-band gain of up to 26dB and a wide supply range of 9V to 26V (it will run from car batteries for caravaners, dry batteries for campers, or a mains battery eliminator at home). No special UHF construction skills are needed - the project could be made by a careful beginner.

There are two parts sets for the project. AA1 contains the printed circuit board, OM335 hybrid amplifier, components and instructions. AA2 is the optional case set: rugged screened box, front and rear panels, waterproofing gaskets, feet, sockets and hardware.

AA1 PARTS SET £12.80 + VAT

AA2 PARTS SET £4.80 + VAT

AA3 OPTIONAL MAINS POWER SUPPLY PARTS SET £6.80 + VAT

POWERFUL AIR IONISER

FEATURED IN ETI
JULY 1986

Ions have been described as vitamins of the air by the health magazines, and have been credited with everything from curing hay fever and asthma to improving concentration and putting an end to insomnia. Although some of the claims may be exaggerated, there is no doubt that ionised air is much cleaner and purer and seems much more invigorating than dead air. The DIRECT ION ioniser caused a great deal of excitement when it appeared as a constructional project in ETI. At last - an ioniser that was comparable with (better than?) commercial products was reliable, good to build, and fun! Apart from the serious applications, some of the suggested experiments were outrageous! We can supply a matched set of parts - fully approved by the designer - to build this unique project. The set includes a roller lined printed circuit board, 66 components, case, mains lead and even the parts for the tester. According to one customer: 'the set costs about a third of the price of the individual components. What more can we say?'



PARTS SET WITH BLACK CASE £12.60 + VAT
PARTS SET WITH WHITE CASE £12.80 + VAT

THE MISTRAL AIR IONISER



The best ioniser design yet - this one has variable ion drive, built-in ion counter and enough power to drive five multi-point emitters. For the technically minded, it has nine main drive stages, five secondary drives, and a four section booster to give an output capability of almost fifteen billion (1.47×10^{10}) ions every minute, or 2.45×10^{11} ions per second. With extra emitters this can be increased still further!

PARTS SET £28.40 + VAT

The parts set includes case, printed circuit boards, 126 top grade components, all controls, lamps, hardware, a multi-point phosphor-bronze emitter and full instructions.

Some parts are available separately - please send SAE for lists, or SAE + £1 for lists, circuit and construction details and further information (free with parts set).

READY-BUILT MISTRAL

The Mistral ioniser (and most of our other projects) can now be supplied built, tested and ready to go. For details, please contact Peter Leah at P.L. Electronics, 8 Woburn Road, Eastville, Bristol BS5 6TT. Tel: 0272 522703. Evenings Only.

INTERNAL EMITTER £2.80 + VAT

Can be used in place of the P-B external emitter, or both can be used together for the highest ion output. Parts set includes PCB, ion emitters, components and instructions.

IPA BOARD CLEANER

Essential for removing grease and flux residues from the Mistral PCB to achieve peak performance. Applicator brush supplied.

£0.98 + VAT

ION FAN

An almost silent piezo-electric fan, mains operated, to pump ions away from the emitter and into the room. Increases the effectiveness of any ioniser by five times!

£9.80 + VAT

BURGLAR BUSTER

Be safe from intruders with our Burglar Buster alarm system! It has all the features you expect from a high-tech alarm: entry and exit delay, anti-lamp loop, delay warning and control-box protection.

The parts set includes all four PCBs and all components to go on them. Other parts (case, switches, etc.) are available separately, if you haven't got anything suitable in your spare box. Set contains 4 PCBs, ICs, transistors, relays, capacitors, resistors, diodes, regulator, piezo sounder and full instructions.

BB1 PARTS SET £12.80 + VAT

LEDs

Green rectangular LEDs for bar-graph displays
50 for £3.50 500 for £25
100 for £5 1000 for £45

DIGITAL AND AUDIO EQUIPMENT LEDs
Assorted 3mm LEDs: red, green, yellow and orange
25 of each (100 LEDs) for £6.80

U.K. orders: please add 80p post and packing and 15% VAT to total.
Ireland and overseas: no VAT. Carriage and insurance £4.50.
Please allow up to 14 days for delivery.

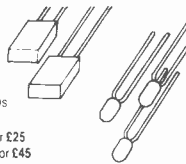

BRAINWAVE MONITOR



FEATURED IN ETI
AUGUST 1987

The most astonishing project ever to have appeared in an electronics magazine. Similar in principle to a medical EEG machine, this project allows you to hear the characteristic rhythms of your own mind! The alpha, beta and theta forms can be selected for study and the three articles give masses of information on their interpretation and powers.

In conjunction with Dr. Lewis's Alpha Plan, the monitor can be used to overcome shyness, to help you feel confident in stressful situations, and to train yourself to excel at things you're not good at.

Our approved parts set contains case, two PCBs, screening can for bio-amplifier, all components (including three PMI precision amplifiers), leads, bare electrodes and full instructions.
PARTS SET £39.80 + VAT ALPHA PLAN BOOK £2.50
SILVER SOLUTION for bare electrodes £3.80 + VAT

Parts set available separately. We also have a range of accessories: professional electrodes, books, etc. Please send SAE for lists, or SAE + £2 for lists, construction details and further information (free with parts set).

Specialist
SEMICONDUCTORS
LIMITED

Tel: (0600) 3715
SALES DEPT., ROOM 108, FOUNDERS HOUSE, REDBROOK, MONMOUTH, GWENT.

Japanese electronics companies are now ready to launch a compact disc that records music and computer data, for replay on a conventional cd player. A twin deck machine, which pairs a recorder with a player, so that commercially pressed cds can be copied onto blank discs, will cost only £80 or £100 more than a conventional cd player. The blank discs will cost under £5. A modified system will be in future be able to record video.

Although the new generation of technology will change the face of the consumer electronics industry, by ousting tape as the most convenient recording medium, Philips of the Netherlands has taken a surprising policy decision not to get involved in the new market until the copyright issues which it raises have been resolved. The chances of resolution are slim, because any cd which records cds inevitably infringes copyright. So although Philips' stance wins the company high moral ground, it may well number Philips' days as a manufacturer of consumer electronics.



describes as "an even greater potential threat than dat". Because the record companies already release their music on cd, a recordable cd offers no new advantages to the record industry.

The IFPI says it learned about the new threat from an internal memo provided by Philips. The memo was written by Angelique Hoogakker, a lawyer who worked for the IFPI before joining Philips in Eindhoven. The Hoogakker memo tells how cheaply cd recorders and blank discs can be made. The Philips memo was triggered by an announcement from Japanese chemical company Taiyo Yuden that it is now ready to manufacture a recordable cd system.

The Taiyo disc is a blank pressed from polycarbonate, superficially similar to a cd, but with a coating of softer plastics and a spiral groove moulded in the surface. This groove guides the laser during recording. A laser of around 7-9mW is used to record music or data pits by modifying a layer of dye, with a 2mW used for play back. Once made, the recording cannot be erased.

BEHAVIOURAL MORALITY

BY BARRY FOX
Winner of the
UK Technology Press Award

**Tapes and cds -
capable of digital
recording in your own
home - cause the
recording industry so
much anxiety that one
major manufacturer
may choose to miss
the boat rather than be
embroiled.**

All the major electronics companies, including Philips, have developed optical discs which can either record once, (cd-r) or erase and record several times (cd-e). But the technology has been seen as too expensive to compete with dat, a digital audio tape cassette the size of a credit card which records several hours of hifi stereo in digital code. Although dat is the ideal medium for releasing 'long form' pre-recorded musical works, such as operas and concerts, the record companies worried about home taping and killed dat by refusing to make programme material available for release.

This cleared the way for cd-r and cd-e which the record companies' trade body the IFPI, (International Federation of Phonogram and Videogram Producers) now

Taiyo claims that shelf life of a blank disc, before recording, is at least ten years, and archival life after recording is at least another ten years. The only proviso is that the discs should not be left in direct sunlight for long periods.

Philips gamely confirms that it will not launch cd-r or cd-e technology until the hardware and software industries have agreed on a copyright strategy. This could take many years because the software industry is in a weak position to bargain and fight the new technology. As most music is already available on cd, there is no permission to refuse.

If Far Eastern firms make cd-e and cd-r the dominant recording media of the future, Philips could be squeezed out of the consumer electronics business altogether. **PE**

ED-LINES

SWEET SATAFAX

We have previously commented in PE's pages of the probability of news texts being distributed by electronic methods rather than in newspaper form. I had expected that this subject would have been one of those discussed at the Home Automation conference on which we reported in PE Apr-May 89. Although this turned out not to be the case, it appears that another of PE's entrepreneurial heroes, Alan Sugar of Amstrad fame, appears to be regarding the electro-news scene with an eagle eye.

Normally reliable sources inform us that Alan Sugar may well enter into the Satafax market, combining the technologies of satellite transmission, computers and fax into a news text distribution facility. And of course the options for such a service don't end with news texts; books and magazines represent some of the other possible candidates for satafax dissemination, and on a worldwide basis. As long as there is power available to run a computer terminal and receiver, the service can be received virtually anywhere around the surface of the globe.

Of course worldwide fax transmission is nothing new, Inmarsat, to whom we refer in the forthcoming Leisure Marine Electronics series of

Jun-Jul 89, is one of those companies who already offer the facility for trans-satellite faxing. The implementation of satellite newspaper transmission, though, is one that could reap fortunes for the operating companies. That is, of course, on the assumption that readers will accept the limited convenience of having to read from a vdu screen, however portable it may be.

I know that commuting business men use portable computers while travelling by train, and so have the hardware for news browsing already under their arm, so to speak. But will they really carry a satafax in place of a paper, even though perhaps the computer might hold all of the day's papers in its memory? I suspect not. Or am I overlooking the undoubted possibility that advances in technology will eventually make satafax terminals as small and convenient as a newspaper? Could be.

Indeed, on this score, I may have an answer to one reader who recently asked what feature and constructional articles PE might be publishing in another 25 years, at the time of our Golden Anniversary. Perhaps we may be publishing a single-chip satafax project that can receive the news, not only from around the globe, but from one or two of the colonised planets as well. If that's the case, then PE itself will possibly be available, not only as a paper-printed magazine, but as a multi-megabyte burst of electronic signals from our own satellite channel.

"The time has come," your Ed has said,
 "To talk of many things;
 Of whose - and which - and crucial
 facts -
 Of theories - and computerings -
 And why PE cares every jot
 On what you think our future
 brings."

Lewis Carroll would probably set an automated Jabberwock on me for reprogramming his immortal lines, ("Off with this Ed!" do I hear another voice cry?), but the time has indeed come when we should ask you to talk with us on many things.

Regular readers of PE will have seen that we have been making various changes to both content and appearance. We think that they are improvements, but I'm not going to get pious about it. We could blow our own trumpets until we are blue in the face, announcing how brilliant each change is and how irresistible you should find it. Codswallop! You know it, and we know it, that at the end of the day, however good we may think our publication is, if you don't like it, you won't buy it.

Well, this issue we've taken further steps along the path of what we believe is the right direction. The cover change is the first thing that should strike you. Ever since Issue One, the relative sizes and styles of the two words "Practical Electronics" have

PRACTICAL ELECTRONICS



EDITORIAL

remained constant. We've now upped the size of "Practical", enhanced the lettering, and increased the descriptive captions. Inside, we have reappraised the layout style and many of the type faces have been changed. This, we feel, gives the contents more visual appeal.

So how right are we? You are the final arbiters on that. We recognise that the changes in this issue are largely cosmetic. The structure remains similar to that found in other recent issues. The balance of constructional projects, technology features, informative theory and product news is largely unaltered, though the new Quick Chip series is one of which we hope you will approve.

What we want to know is, do you think that the structural content of PE should be changed? *And we want to know now!* We ran a survey in 1981 and another in 1986, but the world continues to change, and possibly, you the readers have changed too. During the 80s there has been an upheaval in society; employment patterns have altered drastically; new leisure activities are being catered for; many consumer goods are available which, in some areas, make diy less of an appealing activity; and the trend for instant access to condensed information seems to be increasing, placing question marks over detailed examinations of specific aspects of technology.

My belief is that there will always be a significant core of people who want the pleasure of building things themselves and who enjoy learning by doing. That core, I further believe, includes those who want to be more deeply informed about technology but without having to wade through scores of academic text books, which in any case can seldom be as topical as a monthly magazine.

But, I can only assess the truth of my beliefs by checking my source material. In other words, by asking you, the ones who matter, what you want. Hence the survey questionnaire on pages 35 and 36. Don't ignore it, tell me some answers!

THE EDITOR

Editor:

John Becker

Sub-Editor:

Helen Armstrong

Technical Illustrator:

Derek Gooding

Advertisement Sales:

Sarah Holtham

Business Manager:

Mary-Ann Hubers

Circulation:

David Hewett

Publisher:

Angelo Zgorelec

Editorial and Advertising Address:

Practical Electronics,
 Intra House, 193 Uxbridge Road,
 London W12 9RA
 Tel: 01-743 8888
 Telecom Gold: 87: SQQ567
 Fax: 01-743 3062

Advertisements

All correspondence relating to advertise-



ments, including classified ads, should be addressed to: **The advertisement department, Practical Electronics, at the above address and telephone number.**

Readers' Enquiries

All editorial correspondence should be addressed to the editor and any letters requiring a reply should be accompanied by a stamped addressed envelope, or equivalent payment.

We regret that lengthy technical enquiries cannot be answered over the phone.

Subscription Address:

Practical Electronics, Subscription Dept.,
 P.O. Box 500, Leicester LE99 0AA.

Annual Subscription Rates:

U.K. £15.00 Overseas £18.00

Cover Illustration

Mark Taylor

© Intra Press 1989. Copyright in all drawings, photographs and articles published in PRACTICAL ELECTRONICS is fully protected, and reproduction or imitations in whole or in part are expressly forbidden. All reasonable precautions are taken by PRACTICAL ELECTRONICS to ensure that the advice and data given to readers is reliable. We cannot, however, guarantee it, and we cannot accept legal responsibility for it. Prices quoted are those current as we go to press. All material is accepted for publication on the express understanding that the contributor has the authority to permit us to do so.

Published on 1st Friday of each month by Intrapress, 193 Uxbridge Road, London W12 9RA. Typesetting, artwork and film by Gilfillan Ltd, Mitcham, Surrey and printed in England by McCorquodale Magazines Ltd, Andover, Hants. Distributed by Seymour Press 01-773 4444. PRACTICAL ELECTRONICS is sold subject to the following conditions, namely that it shall not, without the written consent of the Publishers first having been given, be lent, resold, hired out or otherwise disposed of by way of Trade at more than the recommended selling price shown on the cover, and that it shall not be lent, resold, hired out or otherwise disposed of in a mutilated condition or in any unauthorised cover by way of Trade or affixed to or as part of any publication or advertising, literary or pictorial matter whatsoever.

BBC Computer & Econet Referral Centre

AMB15 BBC MASTER £346 (a)		AMB12 BBC MASTER Econet £315 (a)	
A free packet of ten 3.5" DS discs with each Computer			
AMC06 Turbo (65C-02) Expansion Module		ADJ24 Advanced Ref Manual	£19.50 (c)
ADC08 512 Processor	£195 (b)	ADF10 Econet Module	£41 (c)
ADF14 Rom Cartridge	£13 (b)	ADJ23 Ref Manual Part II	£14 (c)
ADJ22 Ref Manual Part I	£14 (c)	BBC Master Dust Cover	£4.75 (d)

BBC MASTER COMPACT		Viewsheet User Guide £10 (d)	
A free packet of ten 3.5" DS discs with each Computer			
SYSTEM 1: 128K Single 640K Drive and bundled software £385 (a)		1770 DFS Upgrade for Model B £43.50 (d)	
SYSTEM 2 System 1 with a 12" Hi-Res RGB Monitor £469 (a)		2 OS ROM £15 (d)	
SYSTEM 3 System 1 with a 14" Med Res RGB Monitor £599 (a)		ACORN 6502 2nd Processor £173 (b)	
Second Drive Kit £99 (c) Extension Cable for 4x1.5 2.5" drive £12.50 (d)		ACORN IEEE Interface £269 (a)	
View 3.0 User Guide £10 (d)		£229 (a)	
BBC Dust Cover £4.50 (d)		£439 (a)	
ADS ROM (Igr B with 1770 DFS & B Plus) £26 (d)			
ACORN Z80 2nd Processor £329 (a)			
MULTIFORM Z80 2nd Processor £289 (b)			
TORCH Z80 2nd Processor ZEP 100			
TZDP 240 ZEP 100 with Technomatic PD800P dual drive with built-in monitor stand			

META Version III - The only package available in the micro market that will assemble 27 different processors at the price offered. Supplied on two 16K roms and two discs and fully compatible with all BBC models. Please phone for comprehensive leaflet £145 (b).

We stock the full range of ACORN hardware and firmware and a very wide range of other peripherals for the BBC. For detailed specifications and pricing please send for our leaflet.

PRINTERS & PLOTTERS

EPSON	STAR NL10 (Parallel Interface)	£209 (a)
EPSON LX86	STAR NL10 (Serial Interface)	£279 (a)
Optional Tractor Feed LX80/86	STAR Power Type	£229 (a)
Sheet Feeder LX80/86		
FX800	BROTHER HR20	£329 (a)
FX1000		
EX800	COLOUR PRINTERS	
LQ800 (80 col)	Dotprint Plus NLQ Rom for	
LQ1000	Epson versions for FX, RX, MX	
	and GLP (BBC only)	£28 (d)
TAXAN	PLOTTERS	
KP815 (160 cps)	Hitachi 672	£459 (a)
KP915 (180 cps)	Graphics Workstation	
	(A3 Plotter)	£599 (a)
JUKI	Plotmate A4SM	£450 (a)
6100 (Daisy Wheel)		
NATIONAL PANASONIC		
KX P1080 (80 col)		£149 (a)

PRINTER ACCESSORIES

We hold a wide range of printer attachments (sheet feeders, tractor feeds etc) in stock. Serial, parallel, IEEE and other interfaces also available. Ribbons available for all above plotters. Pens with a variety of tips and colours also available. Please phone for details and prices.

Plain Fanfold Paper with extra fine perforation (Clean Edge):
 2000 sheets 9.5" x 11" £13(b) 2000 sheets 14.5" x 11" £18.50(b)
 Labels per 1000s: Single Row 3" x 1 7/16" £5.25(d) Triple Row 2-7/16" x 1 7/16" £5.00(d)

MODEMS

All modems carry a full BT approval

MIRACLE TECHNOLOGY WS Range

WS4000 V21/23 (Hayes Compatible. Intelligent. Auto Dial/Auto Answer)	£149 (b)
WS3000 V21/23 Professional As WS4000 and with BELL standards and battery back up for memory	£245 (b)
WS3000 V22 Professional As WS3000 V21/23 but with 1200 baud full duplex	£450 (a)
WS3000 V22 bis Professional As V22 and 2400 baud full duplex	£595 (a)
WS3022 V22 Professional As WS3000 but with only 1200/1200	£350 (a)
WS3024 V22 Professional As WS3000 but with only 2400/2400	£450 (b)
WS2000 V21/V23 Manual Modem	£95 (b)
DATA Cable for WS series/PC or XT	£10 (d)
DATATALK Comms Package * If purchased with any of the above modems *	£70 (c)
PACE Nightingale Modem V21/V23 Manual	£75 (b)

SOFTY II

This low cost intelligent eprom programmer can program 2716, 2516, 2532, 2732, and with an adaptor, 2564 and 2764. Displays 512 byte page on TV. Has a serial and parallel I/O routines. Can be used as an emulator, cassette interface. Softy II £195.00 (b) Adaptor 2764/2564 £25.00

PLEASE TELEPHONE FOR CURRENT PRICES

RT256 3 PORT SWITCHOVER SERIAL INTERFACE
3 input/1 output or 1 input/3 output manual channel selection. Input/output baud rates, independently selectable 7 bit/8 bit, odd even/none parity. Hardware or software handshake. 256K buffer, mains powered £375 (b)

PB BUFFER
Internal buffer for most Epson printers. Easy to install. Inst. supplied. PB128 128K £99 (c)

I.D. CONNECTORS

No of ways	(Speedlock Type)		Edge Conn
	Header	Recep	
10	90p	85p	120p
20	145p	125p	195p
26	175p	150p	240p
34	200p	160p	320p
40	220p	190p	340p
50	235p	200p	390p

D CONNECTORS

	No of Ways			
	9	15	25	37
MALE				
Ang Pins	120	180	230	350
Solder	60	85	125	170
IDC	175	275	325	-
FEMALE:				
St Pin	100	140	210	380
Ang Pins	160	210	275	440
Solder	90	130	195	290
IDC	195	325	375	-
St Hood	90	95	100	120
Screw	130	150	175	-
Lock				

TEXT TOOL ZIF

SOCKETS	24 pin £7.50
	28 pin £9.10
	40 pin £12.10

DISC DRIVES

5.25" Single Drives 40/50 switchable:	
TS400 400K/640K	£114 (b)
PS400 400K/640K with integral mains power supply	£129 (b)
5.25" Dual Drives 40/80 switchable:	
TD800 800K/1280K	£199 (a)
PD800 800K/1280K with integral mains power supply	£229 (a)
PD800P 800K/1280K with integral mains power supply and monitor stand	£249 (a)
3.5" 80T DS Drives:	
TS351 Single 400K/640K	£99 (b)
PS351 Single 400K/640K with integral mains power supply	£119 (b)
TD352 Dual 800K/1280K	£170 (b)
PD352 Dual 800K/1280K with integral mains power supply	£187 (b)
PD853 Combo Dual 5.25"/3.5" drive with p.s.u.	£229 (a)

3M FLOPPY DISCS

Industry Standard floppy discs with a lifetime guarantee. Discs in packs of 10

5 1/4" Discs		3 1/2" Discs	
40 T SS DD	£10.00 (d)	40 T DS DD	£12.00 (d)
80 T SS DD	£14.50 (d)	80 T DS DD	£15.50 (d)
		80 T SS DD	£20.00 (d)
		80 T DS DD	£25.00 (d)

FLOPPICLENE DRIVEHEAD CLEANING KIT

FLOPPICLENE Disc Head Cleaning Kit with 28 disposable cleaning discs ensures continued optimum performance of the drives. 5 1/4" £12.50 (d) 3 1/2" £14.00 (d)

DRIVE ACCESSORIES

Single Disc Cable £6 (d)	Dual Disc Cable £8.50 (d)
10 Disc Library Case £1.80 (d)	30 x 5 1/4" Disc Storage Box £6 (c)
50 x 5 1/4" Disc Lockable Box £9.00 (c)	100 x 5 1/4" Disc Lockable Box £13 (c)

MONITORS

RGB 14"		MONOCHROME	
1431 Std Res	£179 (a)	TAXAN 12" HI-RES	
1451 Med Res	£225 (a)	KX1201G green screen	£90 (a)
1441 Hi-Res	£365 (a)	KX1203A amber screen	£95 (a)
MICROVITEC 14" RGB/PAL/Audio		PHILIPS 12" HI-RES	
1431 AP Std Res	£199 (a)	BM7502 green screen	£75 (a)
1451 AP Std Res	£259 (a)	BM7522 amber screen	£79 (a)
All above monitors available in plastic or metal case		8501 RGB Std Res	£139 (a)
TAXAN SUPERVISION II		ACCESSORIES	
12" Hi-Res with amber/green options		Microvitec Swivel Base	£20 (c)
IBM compatible	£279 (a)	Taxan Mono Swivel Base with clock	£22 (c)
Taxan Supervision III	£319 (a)	Philips Swivel Base	£14 (c)
MITSUBISHI		BBC RGB Cable	£5 (d)
XC1404 14" Med Res RGB, IBM & BBC compatible	£219 (a)	Microvitec	£3.50 (d)
		Taxan ES (d)	Monochrome £3.50 (d)
		Touchtec - 501	£239 (b)

OVERASERS

UV1T Eraser with built-in timer and mains indicator. Built-in safety interlock to avoid accidental exposure to the harmful UV rays. It can handle up to 5 erasors at a time with an average erasing time of about 20 mins. £59 + £2 p&p. UV1 as above but without the timer £47 + £2 p&p. For Industrial users we offer UV140 & UV141 erasers with handling capacity of 14 erasors. UV141 has a built-in timer. Both offer full built-in safety features. UV140 £69, UV141 £85, p&p £2.50

EXT SERIAL/PARALLEL CONVERTERS

Mains powered converters	
Serial to Parallel	£48 (c)
Parallel to Serial	£48 (c)
Bidirectional Converter	£105 (b)

Serial Test Cable

Serial Cable switchable at both ends allowing pin options to be re-routed or linked at either end - making it possible to produce almost any cable configuration on site. Available as M/M or M/F £24.75 (d)

Serial Mini Patch Box

Allows an easy method to reconfigure pin functions without rewiring the cable assy. Jumpers can be used and reused £22 (d)

Serial Mini Test

Monitors RS232C and CCITT V24 Transmissions indicating status with dual colour LEDs on 7 most significant lines. Connects in Line £22.50 (d)

CONNECTOR SYSTEMS

I.D. CONNECTORS

No of ways	(Speedlock Type)		Edge Conn
	Header	Recep	
10	90p	85p	120p
20	145p	125p	195p
26	175p	150p	240p
34	200p	160p	320p
40	220p	190p	340p
50	235p	200p	390p

D CONNECTORS

	No of Ways			
	9	15	25	37
MALE				
Ang Pins	120	180	230	350
Solder	60	85	125	170
IDC	175	275	325	-
FEMALE:				
St Pin	100	140	210	380
Ang Pins	160	210	275	440
Solder	90	130	195	290
IDC	195	325	375	-
St Hood	90	95	100	120
Screw	130	150	175	-
Lock				

TEXT TOOL ZIF

SOCKETS	24 pin £7.50
	28 pin £9.10
	40 pin £12.10

EDGE CONNECTORS

	1" Pitch	0.5" Pitch
2 x 6 way (commodore)	300p	-
2 x 10 way	150p	-
2 x 12 way (vix. 20)	-	350p
2 x 18 way	-	140p
2 x 23 way (ZXR1)	175p	220p
2 x 25 way	225p	220p
2 x 28 way (Spectrum)	200p	-
2 x 36 way	250p	-
1 x 43 way	260p	-
2 x 22 way	190p	-
2 x 43 way	395p	-
1 x 77 way	400p	500p
2 x 50 way (S100conn)	600p	-

EURO CONNECTORS

	Plug	Skt
DIN 41612	230p	275p
2 x 32 way St Pin	275p	320p
3 x 32 way Ang Pin	260p	300p
3 x 32 way St Pin	375p	400p
IDC Skt A + B	400p	-
IDC Skt A + C	400p	-

For 2 x 32 way please specify spacing (A + B, A + C).

MISC CONNS

21 pin Scart Connector	200p
8 pin Video Connector	200p

AMPHENOL CONNECTORS

36 way plug Centronics (solder) 500p (IDC) 475p
36 way skt Centronics (solder) 550p (IDC) 500p
24 way plug IEEE (solder) 475p (IDC) 475p
24 way skt IEEE (solder) 500p (IDC) 500p
PCB Mtg Skt Ang Pin
24 way 700p 36 way 750p

GENDER CHANGERS

25 way D type	
Male to Male	£10
Male to Female	£10
Female to Female	£10

RS 232 JUMPERS

	(25 way D)
24 Single end Male	£5.00
24 Single end Female	£5.25
24 Female Female	£10.00
24 Male Male	£9.50
24 Male Female	£9.50

DIL SWITCHES

4 way	90p	6 way	105p
8 way	120p	10 way	150p

RIBBON CABLE

	19 pin	34 way	160p
10 way	40p	40 way	180p
16 way	60p	50 way	200p
20 way	85p	64 way	280p
26 way	120p		

DIL HEADERS

	Solder	IDC
14 pin	40p	100p
16 pin	50p	110p
18 pin	60p	-
20 pin	75p	-
24 pin	100p	150p
28 pin	160p	200p
40 pin	200p	225p

ATTENTION

74 SERIES **LINEAR ICs** **COMPUTER COMPONENTS**

7400	0.30	74279	1.05	74LS273	1.25	4076	0.65	4077	0.25
7401	0.30	74283	0.90	74LS279	0.70	4078	0.25	4079	0.25
7402	0.30	74287	3.20	74LS280	1.90	4080	0.25	4081	0.25
7403	0.30	74290	0.80	74LS283	0.80	4082	0.25	4083	0.25
7404	0.30	74293	0.90	74LS290	0.80	4085	0.60	4086	0.75
7405	0.36	74296	1.00	74LS293	0.80	4087	0.60	4088	0.75
7406	0.40	74301	2.00	74LS298	1.00	4089	1.20	4090	0.90
7407	0.40	74304	1.80	74LS300	1.40	4091	0.95	4092	0.95
7408	0.30	74307	0.80	74LS303	1.40	4093	0.35	4094	0.90
7409	0.30	74310	1.60	74LS306	1.40	4095	0.95	4096	0.90
7410	0.30	74313	1.20	74LS309	2.20	4097	0.70	4098	0.75
7411	0.30	74316	1.20	74LS312	3.00	4099	0.95	4100	0.95
7412	0.30	74319	1.40	74LS315	3.00	4101	0.95	4102	0.95
7413	0.50	74322	1.00	74LS318	3.00	4103	0.95	4104	0.95
7414	0.70	74325	1.00	74LS321	3.00	4105	0.95	4106	0.95
7415	0.36	74328	1.00	74LS324	3.00	4107	0.95	4108	0.95
7416	0.40	74331	1.00	74LS327	3.00	4109	0.95	4110	0.95
7417	0.40	74334	1.00	74LS330	3.00	4111	0.95	4112	0.95
7418	0.40	74337	1.00	74LS333	3.00	4113	0.95	4114	0.95
7419	0.40	74340	1.00	74LS336	3.00	4115	0.95	4116	0.95
7420	0.30	74343	1.00	74LS339	3.00	4117	0.95	4118	0.95
7421	0.60	74346	1.00	74LS342	3.00	4119	0.95	4120	0.95
7422	0.36	74349	1.00	74LS345	3.00	4121	0.95	4122	0.95
7423	0.36	74352	1.00	74LS348	3.00	4123	0.95	4124	0.95
7424	0.36	74355	1.00	74LS351	3.00	4125	0.95	4126	0.95
7425	0.36	74358	1.00	74LS354	3.00	4127	0.95	4128	0.95
7426	0.36	74361	1.00	74LS357	3.00	4129	0.95	4130	0.95
7427	0.36	74364	1.00	74LS360	3.00	4131	0.95	4132	0.95
7428	0.43	74367	1.00	74LS363	3.00	4133	0.95	4134	0.95
7429	0.30	74370	1.00	74LS366	3.00	4135	0.95	4136	0.95
7430	0.30	74373	1.00	74LS369	3.00	4137	0.95	4138	0.95
7431	0.30	74376	1.00	74LS372	3.00	4139	0.95	4140	0.95
7432	0.36	74379	1.00	74LS375	3.00	4141	0.95	4142	0.95
7433	0.30	74382	1.00	74LS378	3.00	4143	0.95	4144	0.95
7434	0.30	74385	1.00	74LS381	3.00	4145	0.95	4146	0.95
7435	0.30	74388	1.00	74LS384	3.00	4147	0.95	4148	0.95
7436	0.30	74391	1.00	74LS387	3.00	4149	0.95	4150	0.95
7437	0.30	74394	1.00	74LS390	3.00	4151	0.95	4152	0.95
7438	0.40	74397	1.00	74LS393	3.00	4153	0.95	4154	0.95
7439	0.40	74400	1.00	74LS396	3.00	4155	0.95	4156	0.95
7440	0.40	74403	1.00	74LS399	3.00	4157	0.95	4158	0.95
7441	0.90	74406	1.00	74LS402	3.00	4159	0.95	4160	0.95
7442	0.90	74409	1.00	74LS405	3.00	4161	0.95	4162	0.95
7443	0.90	74412	1.00	74LS408	3.00	4163	0.95	4164	0.95
7444	1.00	74415	1.00	74LS411	3.00	4165	0.95	4166	0.95
7445	0.70	74418	1.00	74LS414	3.00	4167	0.95	4168	0.95
7446	1.00	74421	1.00	74LS417	3.00	4169	0.95	4170	0.95
7447	1.00	74424	1.00	74LS420	3.00	4171	0.95	4172	0.95
7448	1.00	74427	1.00	74LS423	3.00	4173	1.20	4174	1.20
7449	0.36	74430	1.00	74LS426	3.00	4175	1.20	4176	1.20
7450	0.36	74433	1.00	74LS429	3.00	4177	1.20	4178	1.20
7451	0.35	74436	1.00	74LS432	3.00	4179	1.20	4180	1.20
7452	0.35	74439	1.00	74LS435	3.00	4181	1.20	4182	1.20
7453	0.38	74442	1.00	74LS438	3.00	4183	1.20	4184	1.20
7454	0.38	74445	1.00	74LS441	3.00	4185	1.20	4186	1.20
7455	0.55	74448	1.00	74LS444	3.00	4187	1.20	4188	1.20
7456	0.55	74451	1.00	74LS447	3.00	4189	1.20	4190	1.20
7457	0.55	74454	1.00	74LS450	3.00	4191	1.20	4192	1.20
7458	1.80	74457	1.00	74LS453	3.00	4193	1.20	4194	1.20
7459	0.55	74460	1.00	74LS456	3.00	4195	1.20	4196	1.20
7460	0.55	74463	1.00	74LS459	3.00	4197	1.20	4198	1.20
7461	0.55	74466	1.00	74LS462	3.00	4199	1.20	4200	1.20
7462	0.55	74469	1.00	74LS465	3.00	4201	1.20	4202	1.20
7463	0.55	74472	1.00	74LS468	3.00	4203	1.20	4204	1.20
7464	0.55	74475	1.00	74LS471	3.00	4205	1.20	4206	1.20
7465	0.55	74478	1.00	74LS474	3.00	4207	1.20	4208	1.20
7466	0.55	74481	1.00	74LS477	3.00	4209	1.20	4210	1.20
7467	0.55	74484	1.00	74LS480	3.00	4211	1.20	4212	1.20
7468	0.55	74487	1.00	74LS483	3.00	4213	1.20	4214	1.20
7469	0.55	74490	1.00	74LS486	3.00	4215	1.20	4216	1.20
7470	0.55	74493	1.00	74LS489	3.00	4217	1.20	4218	1.20
7471	0.55	74496	1.00	74LS492	3.00	4219	1.20	4220	1.20
7472	0.55	74499	1.00	74LS495	3.00	4221	1.20	4222	1.20
7473	0.55	74502	1.00	74LS498	3.00	4223	1.20	4224	1.20
7474	0.55	74505	1.00	74LS501	3.00	4225	1.20	4226	1.20
7475	0.55	74508	1.00	74LS504	3.00	4227	1.20	4228	1.20
7476	0.55	74511	1.00	74LS507	3.00	4229	1.20	4230	1.20
7477	0.55	74514	1.00	74LS510	3.00	4231	1.20	4232	1.20
7478	0.55	74517	1.00	74LS513	3.00	4233	1.20	4234	1.20
7479	0.55	74520	1.00	74LS516	3.00	4235	1.20	4236	1.20
7480	0.55	74523	1.00	74LS519	3.00	4237	1.20	4238	1.20
7481	0.55	74526	1.00	74LS522	3.00	4239	1.20	4240	1.20
7482	0.55	74529	1.00	74LS525	3.00	4241	1.20	4242	1.20
7483	0.55	74532	1.00	74LS528	3.00	4243	1.20	4244	1.20
7484	0.55	74535	1.00	74LS531	3.00	4245	1.20	4246	1.20
7485	0.55	74538	1.00	74LS534	3.00	4247	1.20	4248	1.20
7486	0.55	74541	1.00	74LS537	3.00	4249	1.20	4250	1.20
7487	0.55	74544	1.00	74LS540	3.00	4251	1.20	4252	1.20
7488	0.55	74547	1.00	74LS543	3.00	4253	1.20	4254	1.20
7489	0.55	74550	1.00	74LS546	3.00	4255	1.20	4256	1.20
7490	0.55	74553	1.00	74LS549	3.00	4257	1.20	4258	1.20
7491	0.55	74556	1.00	74LS552	3.00	4259	1.20	4260	1.20
7492	0.55	74559	1.00	74LS555	3.00	4261	1.20	4262	1.20
7493	0.55	74562	1.00	74LS558	3.00	4263	1.20	4264	1.20
7494	0.55	74565	1.00	74LS561	3.00	4265	1.20	4266	1.20
7495	0.55	74568	1.00	74LS564	3.00	4267	1.20	4268	1.20
7496	0.55	74571	1.00	74LS567	3.00	4269	1.20	4270	1.20
7497	0.55	74574	1.00	74LS570	3.00	4271	1.20	4272	1.20
7498	0.55	74577	1.00	74LS573	3.00	4273	1.20	4274	1.20
7499	0.55	74580	1.00	74LS576	3.00	4275	1.20	4276	1.20
7500	0.55	74583	1.00	74LS579	3.00	4277	1.20	4278	1.20

Special offer to PE readers only - 10% off on all TTLs and CMOS

74LS SERIES

4000 SERIES

74S SERIES

FIXED REGULATORS

VARIABLE REGULATORS

SWITCHING REGULATORS

4076	0.65	4077	0.25	4078	0.25	4079	0.25	4080	0.25
4081	0.25	4082	0.25	4083	0.25	4084	0.90	4085	0.95
4086	0.75	4087	0.60	4088	0.75	4089	1.20	4090	0.95
4091	0.95	4092	0.95	4093	0.35	4094	0.90	4095	0.95
4096	0.90	4097	0.70	4098	0.75	4099	0.95	4100	0.95
4101	0.95	4102	0.95	4103	0.95	4104	0.95	4105	0.95
4106	0.95	4107	0.95	4108	0.95	4109	0.95	4110	0.95
4111	0.95	4112	0.95	4113	0.95	4114	0.95	4115	0.95
4116	0.95	4117	0.95	4118	0.95	4119	0.95	4120	0.95
4121	0.95	4122	0.95	4123	0.95	4124	0.95	4125	0.95
4126	0.95	4127	0.95	4128	0.95	4129	0.95	4130	0.95
4131	0.95	4132	0.95	4133	0.95	4134	0.95	4135	0.95
4136	0.95	4137	0.95	4138	0.95	4139	0.95	4140	0.95
4141	0.95	4142	0.95	4143	0.95	4144	0.95	4145	0.95
4146	0.95	4147	0.95	4148	0.95	4149	0.95	4150	0.95
4151	0.95	4152	0.95	4153	0.95	4154	0.95	4155	0.95
4156	0.95	4157	0.95	4158	0.95	4159	0.95	4160	0.95
4161	0.95	4162	0.95						

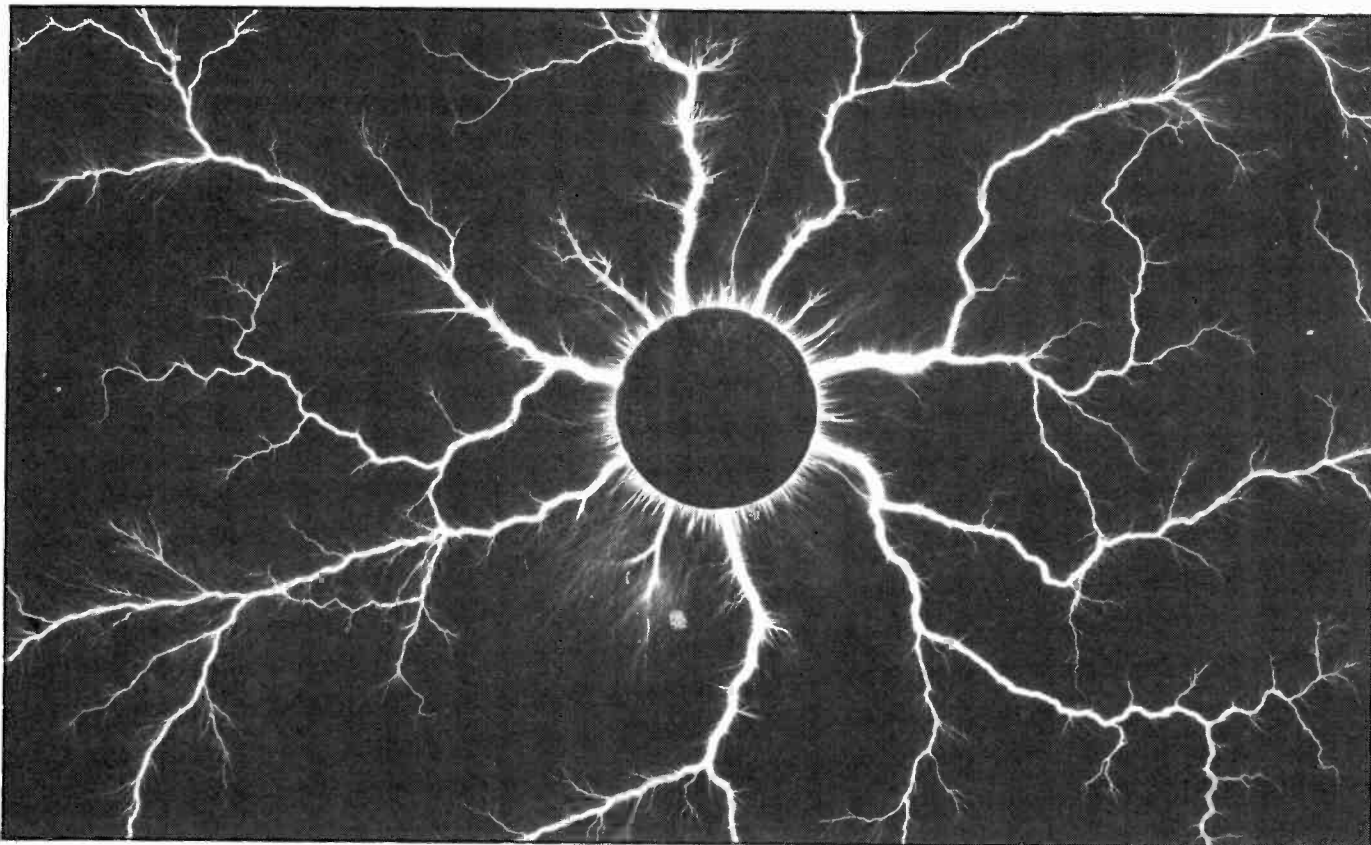

Photo 1. Pattern produced around a 2p coin

KIRLIAN CAMERA

MAY THE FORCE BE WITH YOU

Claims that all living things have an aura or resonating bio-energy field are frequently made by psychic-sensitive people. In general, until about 25 years ago most other people considered the concept as mere speculation or the crazy delusion of credulous table-rapping mediums.

Then an accidental discovery was made in the USSR by Semyon and Valentina Kirlian. They found that when certain biological specimens were placed in an ac ionising field of around 200kHz strange patterns were to be seen around them. The Kirlians claimed that these patterns proved the existence of bio-energy fields and represented scientific evidence of auras.

Following this discovery, researchers in the West, particularly in America, have built their own photographic equipment to verify these claims. They have found that the same sort of patterns can be produced in ionising fields at frequencies as low as 20Hz.

Many American researchers, such as Johnson and Moss, have used low frequency cameras on a wide variety of animate and inanimate objects, and even on human volunteers. They have satisfied themselves that the images produced cannot

BY DON PHILLIPS

Life force or dark horse? A mysterious 'energy corona' - is detected around objects in an ionising field. Is this the psychic aura of old? If so, why do nuts and bolts too? Try it for yourself.

be explained in terms of the normal effects produced by high voltages, chemicals from the photographic process, perspiration or other moisture, and that other conventional explanations are unsatisfactory.

BIOPLASMIC FIELD

Although some researchers in the West believe that the explanation will ultimately be due to a purely physical effect, those in the USSR have put forward the suggestion that it may be due to a "bioplasmic" field. For example, there have been reports that a Kirlian photograph of a leaf section will show the full outline of the original leaf before being cut. There have been suggestions that there is an invisible matrix underlying all matter and that maybe this what many mediums have called the 'etheric' effect.

Following on from this is the suggestion that the Kirlian effect might validate the existence of the 'Chi' and 'Ki' energy as used in acupuncture. If this is the case, perhaps the imaging might be due to a heterodyning effect between the applied frequency and the inherent frequency of the imaged field. In this event it should be possible to image different parts of the surrounding field by altering the frequency of the applied ionisation.



POLYGRAPHY

In support of this, Johnson and Moss have found that different frequencies can reveal different aspects of the field surrounding objects. In particular they have found that the 'phantom leaf' effect only occurs at specific frequencies, evidence which tends to support the heterodyning effect. Many researchers are now investigating the effects produced by very high frequencies, even into the radio frequency ranges.

I have been researching into this fascinating field since 1981 but though I originally experimented with existing circuits for Kirlian cameras, I found they had limited parameters and were unreliable. Consequently, I designed and built my own cameras, and have had some startling results.

Experimentation showed that Kirlian photography could be achieved not only in the presence of ac fields, but also with a pulsed dc field. The latter produced some very strange and at present inexplicable patterns. How this effect ties in with the heterodyning principle is as yet unclear.

However, certain facts became obvious when using both ac and dc cameras. One of the differences is the way in which the cameras and specimens mutually interact. For example, the dc pulse cameras tend to throw the corona away from the specimen and leave the internal structure less defined.

This effect may not be entirely due to the separate applications of either dc or ac in the pure sense, but rather may be due to the initial loading surge through iron cored eht transformers. Further data on this should become available once we have developed an efficient air cored eht transformer for experiments in the rf range. So far, though, certain tests that have been carried out support this idea, including the fact that short ac exposures also divert the energy away from the specimen. It is pertinent to

remember that a dc pulse is simply a special case of an ac waveform and that additionally it may cause 'ringing' at certain harmonics due to the inductive nature of the transformer.

PRACTICAL CAMERA

During my research I have had to build many types of camera. In addition to the pulsed dc version, I built an ac one that was powered from a 12V car battery, then a more ambitious one combining the ac and dc into one unit, and am currently working on an rf camera.

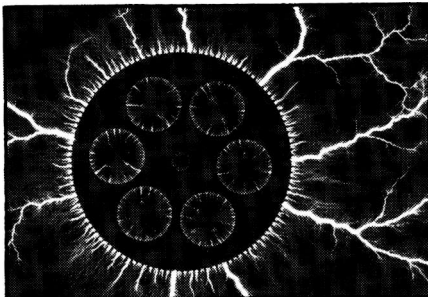

Photo 2. Bronze sprocket.

The circuit I shall describe here, though, is a somewhat simpler one of the ac type. It is powered from the normal 240Vac supply, and is capable of operating at 20Hz to 700Hz. It has the same circuit as one camera I have been using throughout much of my research and has proved to be very reliable. It is of a similar type to those seen and used at various Mind and Body festivals, but I believe it to be more reliable, and it certainly has wider parameters. The main circuit is shown in Fig.1 and its power supply is in Fig.2.

You may wonder why I have used transistors instead of integrated circuits. The reason is due to the transients generated by the high voltage generator and which are difficult to suppress simply and cheaply. Many ics died in my early days of

experimenting! The robustness of the transistors I have used has saved them from the same fate.

Photos 1 to 4 were taken on a dc camera, but photos 5 to 8 were all taken on this ac camera and give an idea of the type of results than can be expected. What the photos *actually* show still needs to be interpreted. However, I am satisfied that the normal explanations offered by critics do not hold water - you must judge for yourself once you have built the camera!

The unit basically comprises a mains operated power supply producing a smoothed but unregulated 37Vdc power rail, a high voltage generator operating at variable frequencies, and a timing circuit.

TIMED EHT GENERATOR

The eht voltage generator consists of a variable rate multivibrator formed around TR3, TR4, T1, and the associated capacitors C16 to C25 selectable by S3. The frequency range is selectable in ten steps between 20Hz and 700Hz, with an additional position for 'off'. Since T1 actively affects the frequency, a high performance coil of the type recommended in the parts list should be used. During frequency generation, the voltage across the primary of T1 swings between +37V and about -37V. The secondary winding then steps up the ac voltage to between about -40kV to -50kV with irregular damped oscillations occurring at 3kHz to 10kHz.

The duration of eht generation is controlled by the gated timing circuit around TR1 and TR2, and is dependent on the charging rate of C4 to C15 as selected by S2. With S1 open, the timing circuit is in its standby state, the relay coil is inactive, and the relay contacts are open, so inhibiting the eht oscillator. On closing S1, the pulse generated across C1 causes TR2 to switch on, so drawing current through the relay coil. The relay contacts close, so allowing

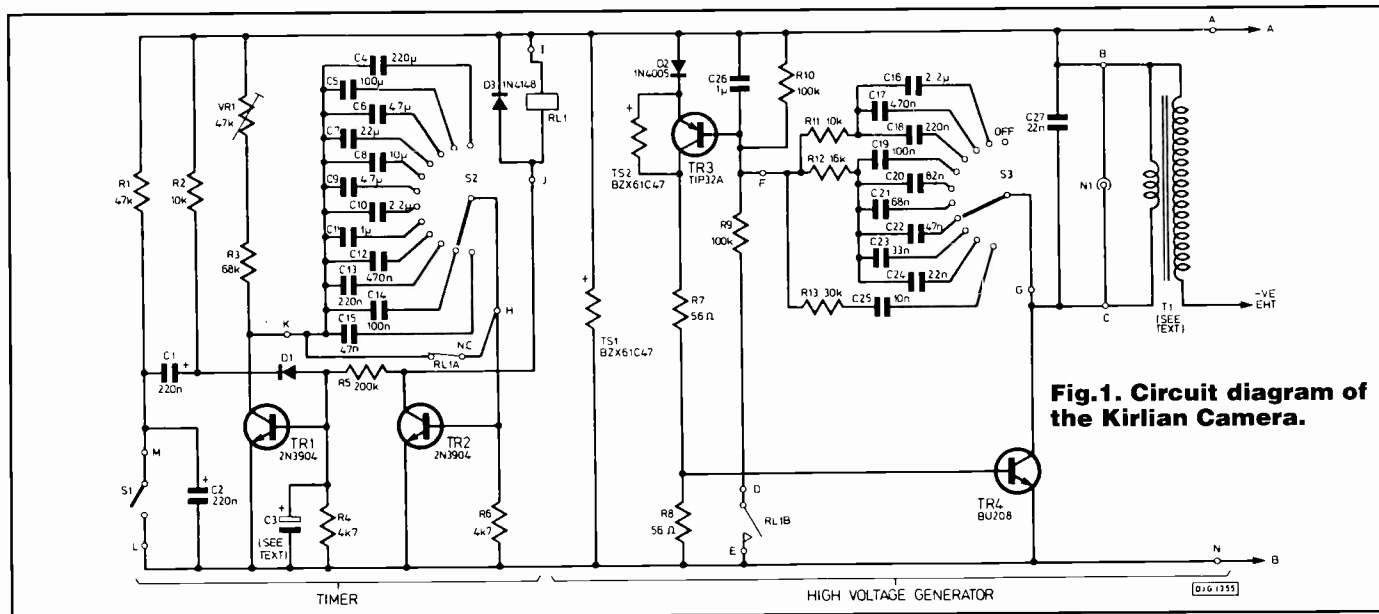

Fig.1. Circuit diagram of the Kirlian Camera.

the eht generator to function. The coil remains active until the capacitor selected by S2 has recharged, so turning off TR2.

The timing range is selectable between about 0.003 sec to 8 secs in twelve steps. VR1 is used to preset the maximum charge rate. Note that C1 and C2 should be high quality tantalum capacitors otherwise the circuit triggering may be inconsistent. C3 is used to damp stray transients that may be radiated by the eht generator so disrupting the timing period. Additional transient suppression is performed by TS1, TS2, C27 and the neon across the primary of T1. The neon has the additional function of providing visual indication that the frequency generator is functioning.

CONSTRUCTION

IT IS IMPORTANT TO NOTE THAT THE UNIT GENERATES VERY HIGH VOLTAGES. EXTREME CARE MUST BE TAKEN DURING TESTING AND USE. KEEP HANDS AWAY FROM THE EHT COIL AND THE ELECTRODE PLATE.

There are three pcbs, as shown in Fig.3. PCB 1 should be mounted as shown in Photo 9; the other two boards are mounted behind the control panel. The mounting platforms should be made from a non-conductive material - I used plywood and chipboard, though srpb board would be equally suitable. When wiring the pcbs together and to the control panel, care should be taken to keep the leads clear of the assembly and box edges to prevent possible chafing. The connections to be made are obvious from the circuit and pcb diagrams - just follow them logically.

Although not used on the prototype, D3 should be soldered across the relay coil, with its positive end on the positive supply tag. Ed.

The unit housing is shown in Photo 10, and it too should be made from a non-metallic material. The prototype box size was 21 x 11 x 5.5 inches, plus a 2.5 inch high lid. Take care when planning the box layout. On my unit, after allowing enough room for an 8 x 10 inch electrode plate, I had just 7 x 10 x 4 inches in which to mount the electronics assembly - a bit of a tight fit. The ignition coil T1 is mounted under the electrode plate, as shown in Photos 10 and 11.

To prevent tracking between the primary and secondary windings, a tight fitting rubber tube some 12 inches long should be pushed over the eht coil nozzle after connecting the eht lead. Then connect the lead to the electrode plate and fill the space between the coil and the plate with layers of rubber foam.

Fig.4 shows the construction of the electrode plate and its mountings. As seen in Photo 11, it is essential to leave a space of at least one inch all around the edges of the plate to prevent field breakdown when large

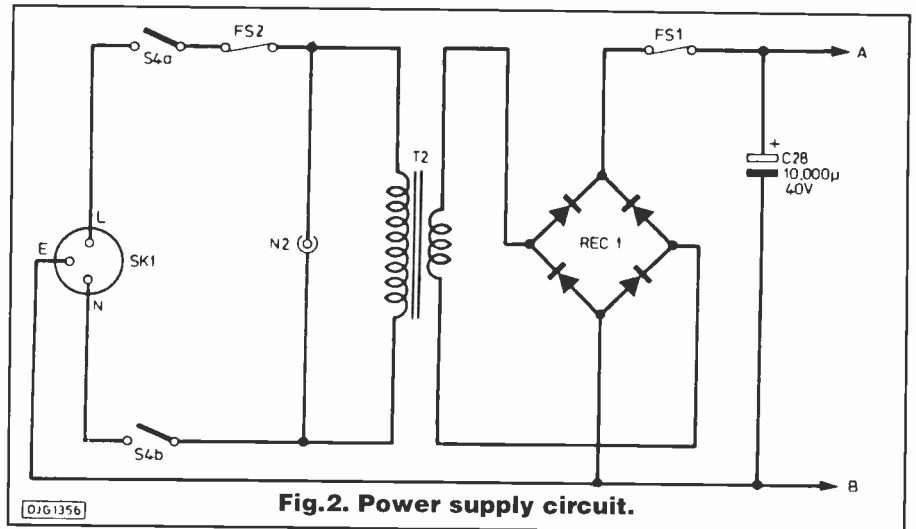

Fig.2. Power supply circuit.

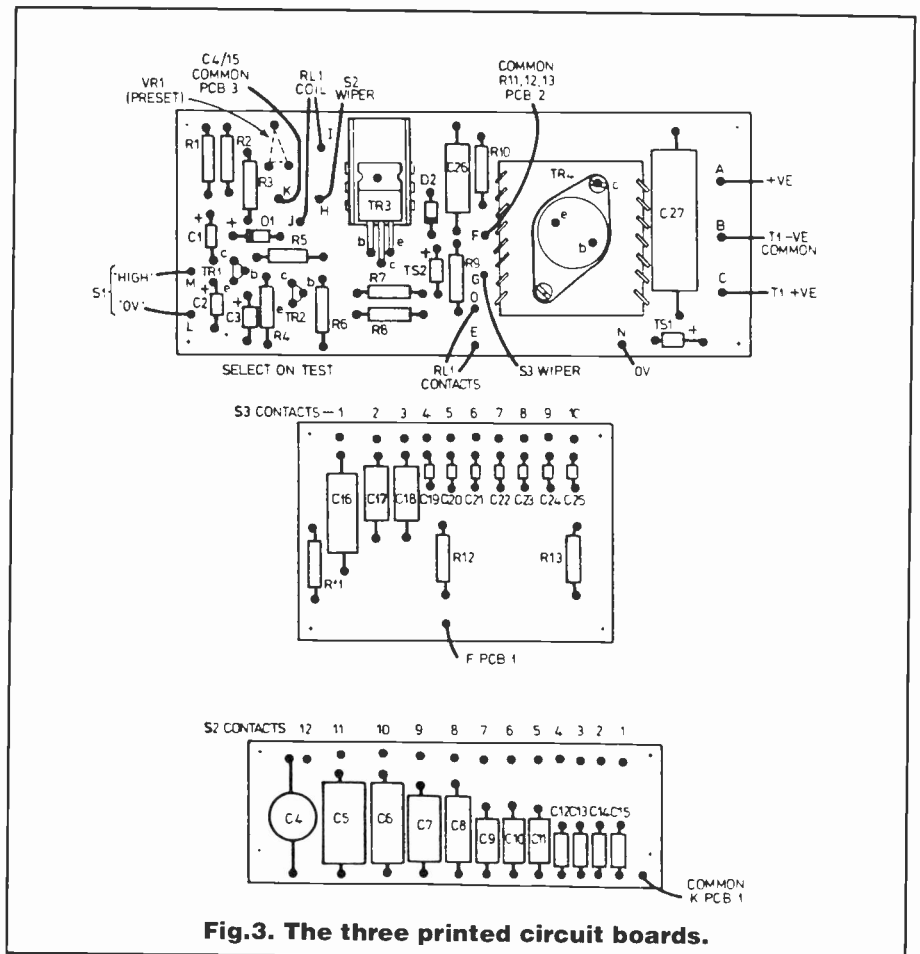

Fig.3. The three printed circuit boards.

specimens are photographed.

Plate glass of at least 2mm thick is placed over the electrode to insulate it; this too should extend around the plate by at least one inch. It should be secured in place by quarter inch hardwood battens screwed to the sides of the box. Acrylic sheeting could be used as an alternative, but plate glass is preferable since acrylic tends to become etched with markings caused by the ionising field.

Photo 12 shows the completed unit and a guide to the control legends, though note that this is a photo of the prototype and the final legends will differ slightly.

TESTING

Timer setting is best done with the frequency control in the off position. VR1 is used to adjust the timing range, using the one second position as the reference. While observing the neon and preferably using a digital stop watch, repeatedly trigger the circuit and adjust VR1 until a delay of precisely one second is obtained. Within the normal tolerances of the other capacitors, the other ranges should follow proportionately. Though a nominal value of 2µF is quoted for C3, it is best to select its



ideal value on test. With the timing switch set for one second, switch the frequency control from setting to setting, each time triggering the circuit and timing its delay on a stop watch. If the timing terminates before one second has lapsed, C3 may be increased in value up to a maximum of 10uF. Increasing it beyond 10uF could affect the triggering.

PHOTOGRAPHY

Photographs are taken by first laying a sheet of photographic bromide film on the electrode plate cover, emulsion side up, (Fig.5). The specimen is placed on the film, the ionising frequency selected and the unit

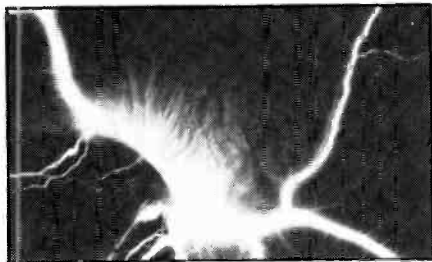

Photo 3. Panadol tablet

triggered for the desired time. The exposure is then developed in a normal bromide developer. Naturally, the exposing and developing must be done under suitable safelight conditions. Panchromatic sheet film may be used instead if more detailed imaging is desired, but exposing and developing must done under total darkroom

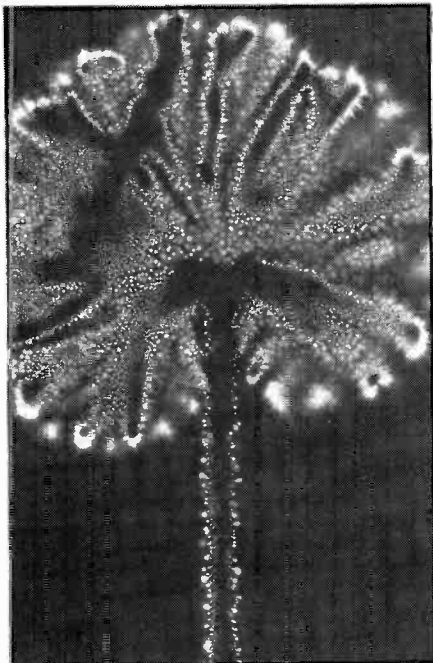

Photo 5. Geranium leaf

conditions. Though film is more expensive than photographic paper it has the advantage of allowing enlargement prints to be made of selected areas.

When photographing inanimate objects,

such as leaves, metallic specimens, chemical compounds, etc, the ground lead (marked as the negative electrode on the panel) may be connected to the upper surface of the specimen to enhance the discharge path.

ON NO ACCOUNT MUST THE GROUND CONNECTION BE USED IF PHOTOGRAPHING ANY PART OF THE HUMAN BODY.

(I feel obliged to warn against using the unit to photograph any living creature.

Ed).

Providing you do not earth yourself in any way, finger tips may be photographed by lightly touching them to the paper or film (Fig. 6) - the body's natural capacitance allows for completion of the ionising path.

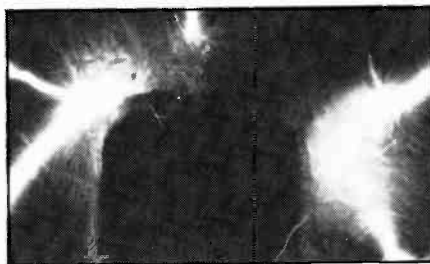

Photo 4. Rennie tablet

Photographing the complete hand is not recommended since the hand will dissipate the energy too much to produce satisfactory results. Be warned against attempting to increase the unit's energy output since this could be dangerous.

I am sure that Don Phillips will be pleased to hear about interesting results produced by readers using this Kirlian camera. He can be contacted at Aldon Paraphysical Research, 147 Butchers Road, Canning Town, London E16 1NE. Ed.

SUGGESTED EXPERIMENTS

Your Ed suggests that some of the questions you might care to seek answers to when using your camera are :

Photo 6. House key

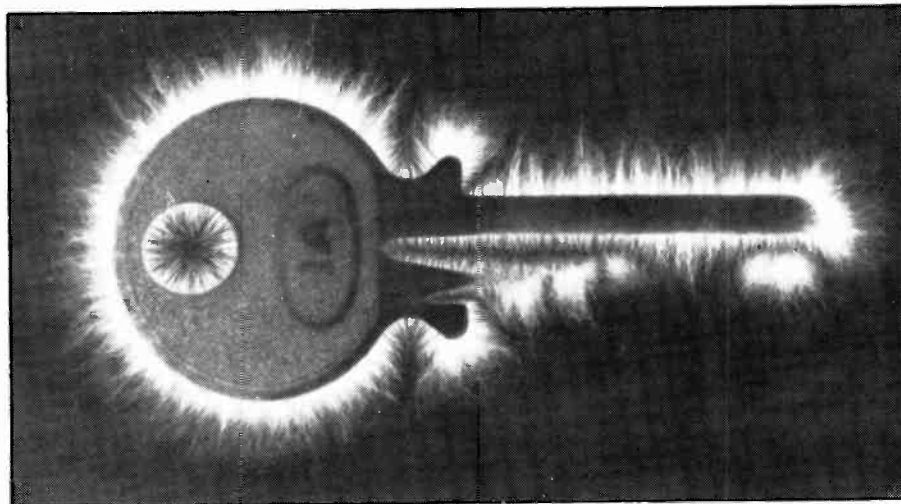

1. How different are the images produced by the same object at different frequencies and timing periods?

2. Are the images different when different photographic materials are used, eg. bromide or pan film?

3. Does humidity or temperature have an effect on the images? Don says this may be difficult to arrange but is essential, if only to rule out that moisture makes no valid difference.

4. Do the images change if the object is placed in different positions on the electrode plate? "A waste of time", says Don, "it will make no difference". Do you agree?

5. In the finger experiment, does the state of mind or physical well-being of the subject have any effect on the images? Don comments that this is the best test of all but is difficult to assess unless carried out

Photo 7. Finger tips

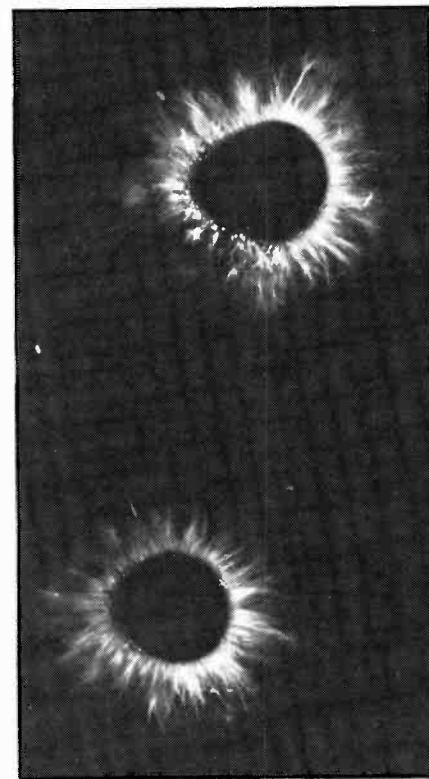

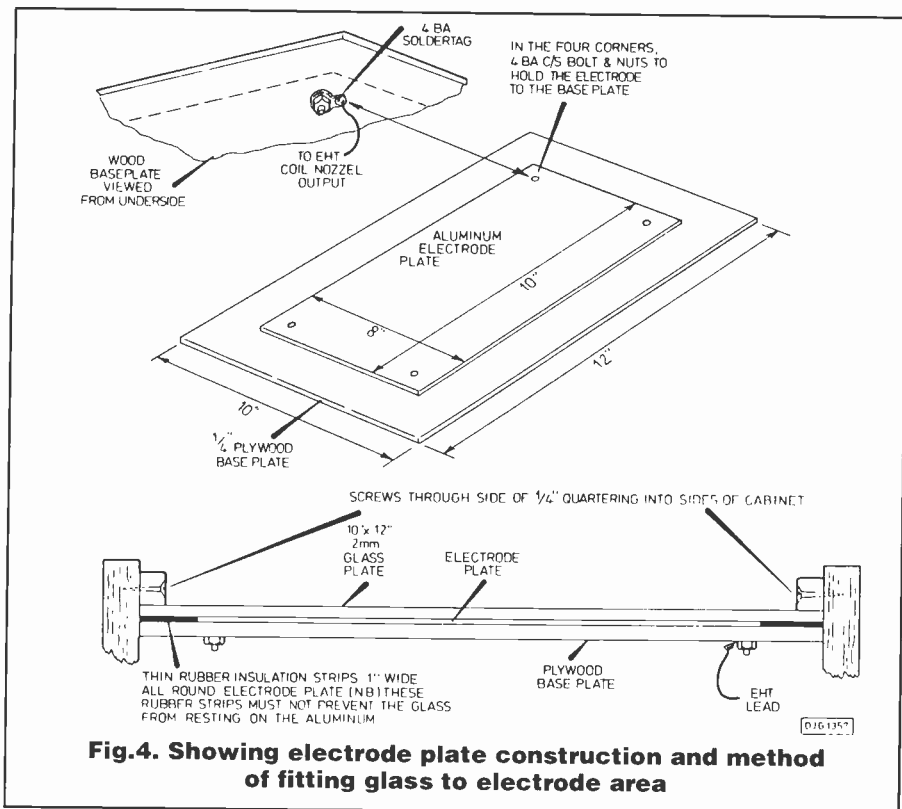

Fig. 4. Showing electrode plate construction and method of fitting glass to electrode area

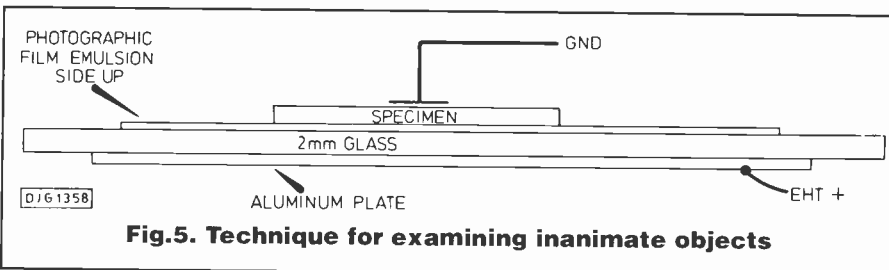

Fig. 5. Technique for examining inanimate objects

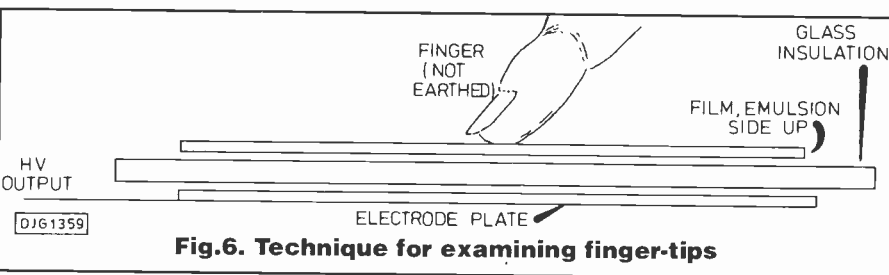

Fig. 6. Technique for examining finger-tips

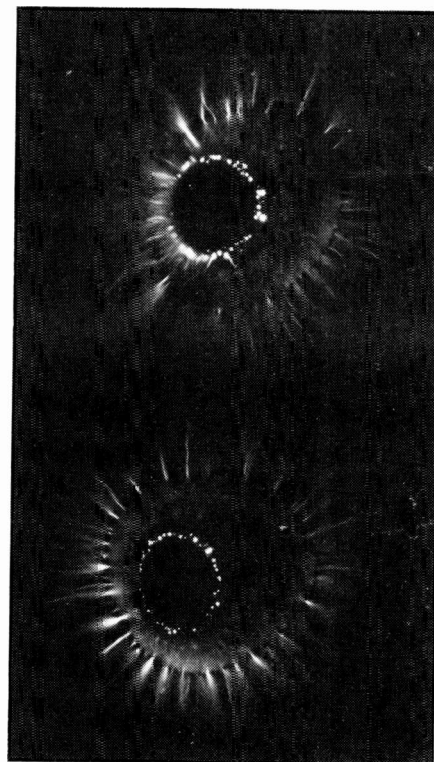

Photo 8. More finger tips

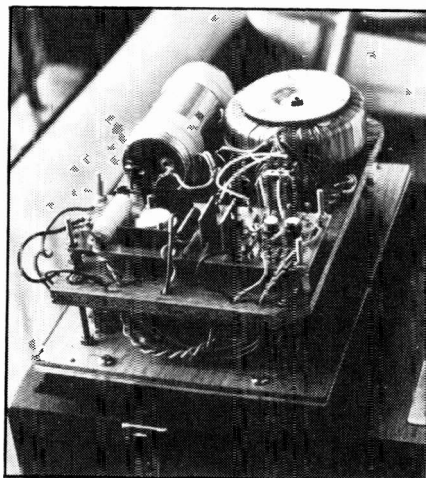

Photo 9. Mounting of power supply

under medical supervision and performed on numerous occasions to establish a statistically significant data base.

FURTHER READING

The Dark Side of the Brain (major discoveries in the use of Kirlian Photography and electrocrystal therapy). Harry Oldfield and Roger Coghill. Element Books. (Harry Oldfield is reputedly the leading researcher in Britain on Kirlian photography.)

Galaxies of Life. Krippner and Rubin. Anchor Books.

Photographing the Non-material World. Kendal Johnson. Aquarian Press.

COMPONENTS

RESISTORS

R1	47k
R2,R11	10k (2 off)
R3	6k8
R4,R6	4k7 (2 off)
R5	200k
R7,R8	56R (2 off)
R9,R10	100k (2 off)
R12	16k
R13	30k

All resistors 0.5W 5% carbon.

POTENTIOMETER

VR1	47k horiz preset
-----	------------------

CAPACITORS

C1,C2,C13	220n 35V tantalum (3 off)
C3	2µF to 10µF 35V tant (see text)
C4	220µF 63V
C5	100µF 63V
C6	47µF 63V
C7	22µF 63V
C8	10µF 63V
C9	4.7µF 63V
C10	2.2µF 63V
C11	1µF 63V
C12	470n 63V
C14,C19	100n polyester (2off)
C15	47n polyester
C16	2.2µF polyester

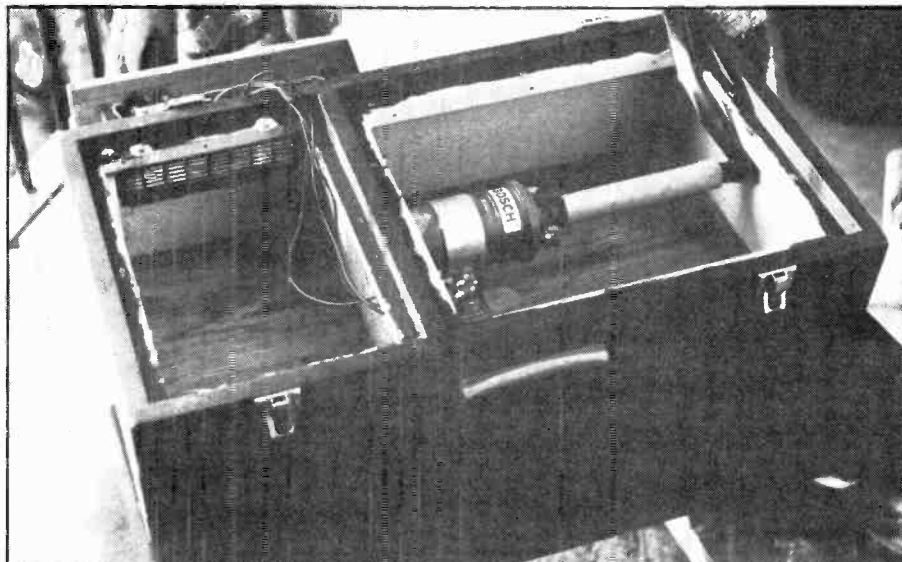

Photo 10. Interior box showing coil mounting

- C17 470n polyester
 - C18 220n polyester
 - C20 82n polyester (or 47n + 33n in parallel)
 - C21 68n polyester
 - C22 47n polyester
 - C23 33n polyester
 - C24 22n polyester
 - C25 10n polyester
 - C26 1 μ F 63V metal film
 - C27 22n 1500V polypropylene
 - C28 10,000 μ F 40V elect
- All 63V caps are single ended electrolytics unless marked. Polyester capacitors shown have a 250V rating.

SEMICONDUCTORS

- D1,D3 1N4148 (2 off)
- D2 1N4005
- TS1,TS2 BZX61C47 transient suppressors (2 off)
- TR1,TR2 2N3904 (2 off)
- TR3 TIP32A
- TR4 BU208
- REC1 50V 6A bridge rectifier

SWITCHES

- S1 sp push make, or microswitch
- S2,S3 1p12w rotary (2 off)
- S4 dpst rotary mains
- RL1 24V 650R dpdt relay

TRANSFORMERS

- T1 12V ignition coil (Lucas super energy)
- T2 25V + 25V 80VA toroidal, 1.6A per winding (ILP Electronics 3X016)

SOCKETS

- SK1 IEC mains connectors
- SK2 BNC 50 ohm socket (and plug)
- SK3 4mm banana socket and plug (NEG electrode)

ELECTRODE ASSEMBLY

Electrode plate 204 x 254 x 1.2mm aluminium sheet (see text)
 Electrode insulation 300 x 252 x 2mm plate glass (see text)

MISCELLANEOUS

- FS1 2.5A antisurge fuse and holder (20mm)
 - FS2 1A antisurge fuse and holder (20mm)
 - LP1 mains neon (red)
 - LP2 mains neon (orange)
- Capacitor clip for C28. Heatsink TO3 7.2 $^{\circ}$ C vained for TR4 (eg. Maplin FL59P). Heat sink 17 $^{\circ}$ C vained for TR3 (eg. Maplin FL58N). Knobs (3 off). EHT lead 30kV 300mm length. Case materials to suit.

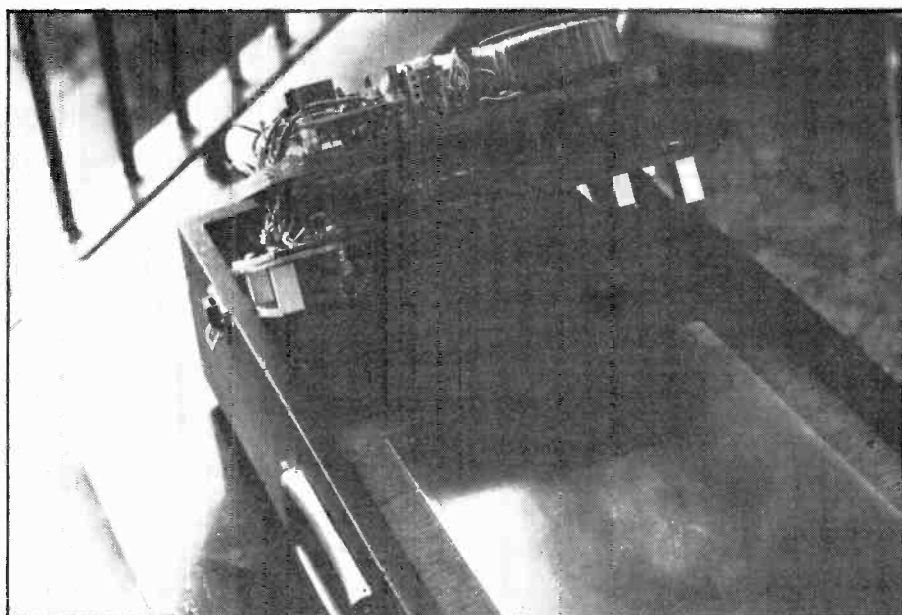
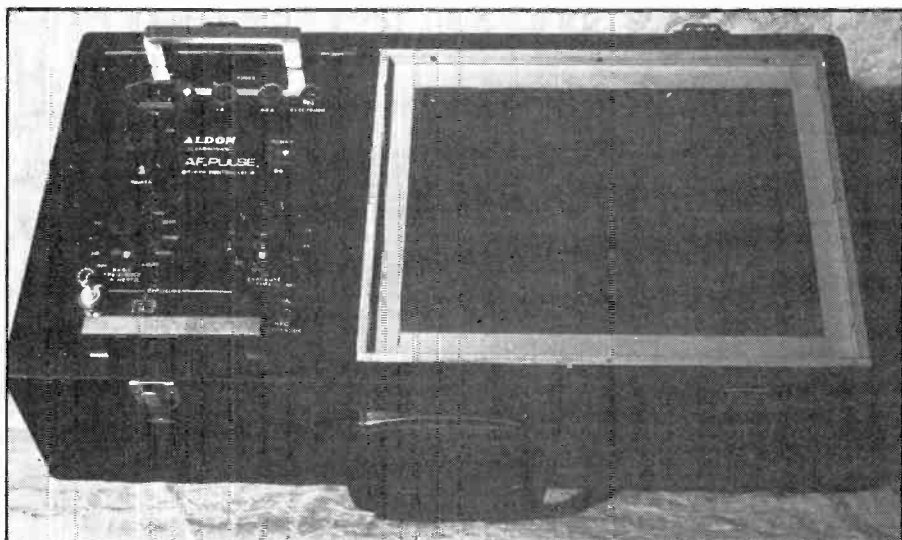

Photo 11. Showing plate and power supply mounting

Photo 12. Author's complete Kirlian dc camera



THE 'ALADDIN'S' CAVE OF ELECTRONIC & COMPUTER EQUIPMENT

COLOUR MONITORS

16" Decca, 80 series budget range, colour monitors, features include: PIL tube, attractive teak style case, **guaranteed 80 column resolution**, only seen on monitors costing 3 times our price, ready to connect to a host of computer or video outputs. Manufacturers fully tested surplus, sold in little or hardly used condition with 90 day full RTB guarantee. **1000's Sold to date.**
DECCA 80 RGB - TTL + SYNC input for BBC type interface etc
DECCA 80 COMP 75 composite video input with integral audio amp & speaker ideal for use with video recorder or TELEBOX ST or any other audio visual use.
Only £99.00 (E)

HIGH DEFINITION COLOUR

BRAND NEW CENTRONIC 14" monitors in attractive style moulded case featuring hi res Mitsubishi 0.42 dot pitch tube with 669 x 507 pixels. 28MHz bandwidth. Full 90 day guarantee.
 Order as **1004-N2** for TTL + sync RGB for BBC etc **£159.00 (E)**
1003-N1 for IBM PC etc fully CGA equiv **£189.00 (E)**
1005-N2 RGB interface for QL 85 columns. **£169.00 (E)**

20" & 22" AV Specials

Superbly made, UK manufacture, PIL tube, all solid state colour monitors, complete with composite video and sound inputs, attractive teak style case, ideal for a host of applications including Schools, Shopp, Disco's, Clubs etc. Supplied in EXCELLENT little used condition with 90 day guarantee.
20" Monitor £165.00 (F) **22" Monitor £185.00 (F)**

MONOCHROME

MOTOROLA M1000-100 5" CRT black & white compact chassis monitor measuring only 11 1/2" x 12" x 22". Ideal for CCTV or computer applications. Accepts standard composite video or individual H & V syncs. Operates from 12V DC at approx 0.8A. Some units may have minor screen marks, but still in very usable condition. Fully tested with 30 day guarantee & full data. **Only £29.00 (C)**
Fully cased as above, with attractive moulded, desk standing swivel and tilt case Dim. cm 12h, 14w, 26d **£39.00 (C)**
JVC type 751-7 5" ultra compact black & white chassis monitor for 12v 0.7A DC operation Dim cm 11h, 14w, 18d. Simple DIY circuit data included to convert data and separate sync input to composite video input. Ideal portable equipment etc. Supplied with full data. **Brand New £65.00 (B)**
KGM 324 9" Green Screen, Little used fully cased, mains powered high res monitors with standard composite video input. Fully tested and in excellent condition. **£49.00 (E)**
20" Black & White monitors by AZTEK, COTRON & NATIONAL. All solid state, fully cased monitors, ideal for all types of AV or CCTV applications. Units have standard composite video inputs with integral audio amp and speaker. Sold in good, used condition - fully tested with 90 day guarantee. **Only £85.00 (F)**

FLOPPY DRIVE SCOOP

A MASSIVE purchase of about 5.25" disk drives enables us to offer you prime product at all time super low prices. All units unless stated are removed from often BRAND NEW equipment, fully tested and shipped to you with a full 120 day guarantee. All units offered operate from +5 and +12 volts DC, are of standard size and accept the common standard 34-way interface connector.
TANDON TM100-2A IBM compatible 40 track FH double sided **Only £39.95 (B)**
TANDON TM101-4 FH 80 track double sided **Only £49.95 (B)**
JAPANESE Half double sided drives by Canon, Tec, Toshiba etc. Specify 40 or 80 track **Only £75.00 (B)**
TEAC FD55-F 40-80 track double sided Half Height **Brand New £115.00 (B)**

DISK DRIVE ACCESSORIES

34 Way interface cable and connector single **£5.50**, Dual **£8.50 (A)**
 5.25" DC power cable **£1.75**. Fully cased PSU for 2 x 5.25" Drives **£19.50 (A)** Chassis PSU for 2 x 8" drives **£39.95 (B)**

8" DISK DRIVES

SUGART 800/801 single sided refurbished **£175.00 (E)**
SUGART 851 double sided refurbished **£260.00 (E)**
MITSUBISHI M2894-63 Double sided switchable Hard or Soft sector. **BRAND NEW £275.00 (E)**
SPECIAL OFFER Dual 8" drives with 2mb capacity in smart case with integral PSU **ONLY £499.00 (F)**

COMPUTER SYSTEMS

TATUNG PC2000. Big brother of the famous EINSTEIN, the TPC2000 professional 3 piece system comprises. Quality high green GREEN 12" monitor, Sculptured 92 key keyboard and pinball unit containing the Z80A CPU and all control electronics PLUS 2 integral TEAC 5.25" 80 track double sided disk drives. Many other features include Dual 8" IBM format disk drive support. Serial and parallel outputs. Full expansion port. 64k ram and ready to run software. Supplied complete with CPM, WORDSTAR, BASIC and accounts package. **BRAND NEW**
 Full 90 day guarantee **Only £299(E)**
EQUINOX (IMS) S100 system capable of running either TURBO or standard CPM. Unit features heavy duty box containing a powerful PSU, 12 slot S100 backplane, & dual 8" double sided disk drives. Two individual 280 cpu boards with 192k of RAM allowed the use of multi user software with upto 4 RS232 serial interfaces. Many other features include battery backed real time clock, all IC's socketed etc. Units in good condition and tested prior despatch, no documentation at present. **Price from only £245.00 (F)**
S100 PCB's IMS A465 64k dynamic RAM **£55.00 (B)** IMS A930 FDC controller **£85.00 (B)**. IMS A862 CPU & i/o **£65.00 (B)**
 SAE for full list of other S100 boards and accessories.

PRINTERS

Bulk purchase brings you incredible savings on a range of printers to suit all applications. Many other "one off bargains" can be seen at our South London Shop.
HAZELTINE ESPRINT Small desktop 100 cps print speed with both RS232 and CENTRONICS interfaces. Full pin addressable graphics and 6 user selectable type fonts. Up to 9.5" single sheet and tractor paper handling. **Brand New Only £199.00 (E)**
CENTRONICS 150 series. A real workhorse for continuous use with tractor feed paper, either in the office, home or factory, desk standing, 150 cps 4 type fonts and choice of interfaces. Supplied **BRAND NEW** Order as:
150-SN up to 9.5" paper handling **£185.00 (E)**
150-SW up to 14.5" paper handling **£225.00 (E)**
150-GR up to 14.5" paper plus full graphics **£245.00 (E)**
 When ordering please specify RS232 or CENTRONICS interface.

Ultra Fast 240 cps NEWBURY DATA NDR 8840 High Speed Printers Only £449 !!

A special purchase from a now defunct Government Dept enables us to offer you this amazing British Made, quality printer, at clearance prices, **SAVING YOU OVER £1500 !!** The **NDR8840** features high speed 240 cps print speed with integral, fully adjustable paper tractor, giving exceptional fast paper handling for multi part forms etc. The unit features 10 selectable type fonts giving up to 226 printable characters on a single line. Many other features include internal electronic vertical and horizontal tabs, Self test, 9 needle head, Up to 15.5" paper, 15 million character ribbon cartridge life and standard RS232 serial interface. Sold in SUPERB tested condition with 90 day guarantee. **Only £449.00 (F)**
EPSON model 512 40 column 3.5" wide paper roll feed, high speed matrix (3 lines per second) printer mechanism for incorporation in point of sale terminals, ticket printers, data loggers etc. Unit features bi directional printhead and integral roll paper feed mech with tear bar. Requires DC volts and simple parallel external drive logic. Complete with data. RFE and tested. **Only £49.95 (C)**
EPSON model 542 Same spec as above model, but designed to be used as a slip or flatbed printer. Ideal as label, card or ticket printer. Supplied fully cased in attractive, small, desk top metal housing. Complete with data. RFE and tested. **Only £55.00 (D)**
PHILIPS P2000 Heavy duty 25 cps bi directional daisy wheel printer. Fully DIABLO, QUME, WORDSTAR compatible. Many features include full width padding - up to 15" paper, host of available daisy wheels, single sheet paper handling, superb quality print. Supplied complete with user manual & 90 day guarantee plus FREE dust cover & daisy wheel. **BRAND NEW Only £225.00 (E)**

POWER SUPPLIES

All power supplies operate from 220-240 v AC. Many other types from 3v to 10kV in stock. Contact sales office for more details.
PLESSEY PL12/2 Fully enclosed 12v DC 2 amp PSU. Regulated and protected. Dim cm 13.5 x 11 x 11 **New £16.95 (B)**
AC-DC Linear PSU outputs of +5v 5.5A, -5v 0.6A, +24v 5A. Fully regulated and short proof. Dim cm 28 x 12.5 x 7 **New £49.50 (C)**
POWER ONE PHC 24V DC 2 amps Linear PSU fully regulated. **New £19.95 (B)**
BOSHERT 13088 switch mode supply ideal disk drives or complete system +5v 6A, +12 2.5A, -12 0.5A, -5v 0.5A. Dim cm 5.6 x 21 x 10.8 **New £29.95 (B)**
BOSHERT 13090 same as above spec but outputs of +5v 6A, +24v 1.5A, +12v 0.5A, -12v 0.5A **New £39.95 (B)**
GREENDALE 19AB06 60 Watt switch mode outputs +5v 6A, +12v 1A, -12v 1A, +15v 1A D 11 x 20 x 5.5 **RFE Tested £24.95 (B)**
CONVER AC130-3001 High grade VDE spec compact 130 watt switch mode PSU. Outputs give +5v 15A, -5v 1A, + & -12v 6A. Dim 6.5 x 27 x 12.5 Current limit price £190. Our price **New £59.95.00 (C)**
FARNELL G6/40A Compact 5v 40 amp switch mode fully enclosed. **New £140.00 (C)**
FARNELL G24 5S Compact 24v 5 amp switch mode fully enclosed. **Only £95.00 (C)**

Special Offer EXPERIMENTORS PSU Only £16.95 (C)

Made to the highest spec for BT this unit gives several fully protected DC outputs most suited to the Electronics Hobbyist, +5v 2A, + & -12v 1A, +24v 1A and +5v fully floating at 50mA. Ideal for school labs etc. Quantity discount available. Fully tested with data. RFE = Removed From Equipment

The AMAZING TELEBOX Converts your monitor into a QUALITY COLOUR TELEVISION

Brand new high quality, fully cased, 7 channel UHF PAL TV tuner system. Unit simply connects to your TV aerial socket and video monitor turning same into a fabulous colour TV. Don't worry if your monitor doesn't have sound, the TELEBOX even has an integral audio amp for driving a speaker plus an auxiliary output for Headphones or Hi Fi system etc. Many other features: LED Status indicator, Smart moulded case, Mains powered, Built to BS safety specs. Many other uses for TV sound or video etc. Supplied BRAND NEW with full 1 year guarantee. Carriage code (B)



TV SOUND & VIDEO TUNER ONLY £29.95

TELEBOX ST for monitors with composite video input **£29.95**
 TELEBOX ST as ST, but fitted with integral speaker **£34.95**
 TELEBOX RGB for use with analogue RGB monitors **£59.95**

Colour when used with colour CRT. RGB version NOT suitable for IBM-CLONE type colour monitors. DATA sheet on request. PAL & overseas versions CALL.

** South London Shop **

Located at 215 Whitehorse Lane, London SE25. The shop is on the main 68 bus route and only a few miles from the main A23 and South Circular roads. Open Monday to Saturday from 9 to 5.30. parking is unlimited and browsers are most welcome. Shop callers also save the cost of carriage.

MODEMS

Modems to suit all applications and budgets. Please contact our technical sales staff if you require more information or assistance.

SPECIAL PURCHASE V22 1200 baud MODEMS ONLY £149 !!

MASTER SYSTEMS type 2/12 microprocessor controlled V22 full duplex 1200 baud. This fully BT approved modem employs all the latest features for error free data comms at the staggering speed of 120 characters per second, saving you 75% of your BT phone bills and data connect time !! Add these facts to our give away price and you have a superb buy !! Ultra slim unit measures only 45 mm high with many integral features such as Auto answer, Full LED status indication, RS232 interface, Remote error diagnostics, SYNC or ASYNC use, SPEECH or DATA switching, integral mains PSU, 2 wire connection to BT line etc. Supplied fully tested, EXCELLENT slightly used condition with data and full 120 day guarantee.

LIMITED QUANTITY Only £149 (D)

CONCORD V22 1200 baud as new **£330.00 (E)**
CONCORD V22 1200-2400 BIS **£399.00 (E)**
RIXON Ex BT Modem 27 V22 1200 **£225.00 (E)**
DATel 4800 / RACAL Myns 4800 Ex BT modem for 4800 baud sync use. **£295.00 (E)**
DATel 2412 2780/3780 4 wire modem unit. EX BT fully tested. **£199.00 (E)**
MODEM 20-1 75-1200 BAUD for use with PRESTEL etc EX BT fully tested. **£49.00 (E)**
TRANSDATA 307A 300 baud acoustic coupler with RS232 i/o. **Brand New £49.00 (E)**
RS232 DATA CABLES 16 ft long 25w D plug to 25 way D socket. Brand New **Only £9.95 (A)**
 As above but 2 metres long **£4.99 (A)**
 BT plug & cable for new type socket **£2.95 (A)**

RECHARGEABLE BATTERIES

Maintenance free, sealed long life LEAD ACID
A300 12v 3 Ah **£13.95 (A)**
A300 6v 3 Ah **£9.95 (A)**
A300 6-0-6 v 1.8 Ah **RFE £5.99 (A)**
NICKEL CADMIUM
 Quality 12 v 4 Ah cell pack. Originally made for the TECHNICOLOUR video camera, this unit contains 10 high quality GE nicad, D type cells, configured in a smart robust moulded case with DC output connector. Dim cm 19.5 x 4.5 x 12.5. Ideal portable equipment etc. **BRAND NEW £24.95 (B)**
12v 17 Ah Ultra rugged, all weather, virtually indestructible refillable NICAD stack by ALCAD. Unit features 10 x individual type XL1.5 cells in wooden crate. Supplied to the MOD and made to deliver exceptionally high output currents & withstand long periods of storage in discharged state. Dim cm 61 x 14 x 22. Cost over £250. Supplied unused & tested complete with instructions. **£95.00 (E)**
EX EQUIPMENT NICAD cells by GE. Removed from equipment and believed in good, but used condition. 'F' size 7Ah 6 for £8 (B). Also 'D' size 4Ah 4 for £5 (B).

BRAND NEW 85 Mb Disk Drives ONLY £399

End of line purchase enables this brand new unit to be offered at an all time super low price. The **NEC D2246 8" 80 Mb** disk drive features full CPU control and industry standard SMD interface, Ultra high speed data transfer and access times leave the good old ST506 interface standing. Supplied **BRAND NEW** with full manual. **Only £399.00 (E)**
 Dual drive, plug in 135 Mb sub system for IBM AT unit in case with PSU etc. **£1499.00 (F)**
 Interface cards for upto 4 drives on IBM AT etc available. **Brand new at £395.00**

COOLING FANS

Keep your hot parts COOL and RIT LAMB F with our range of BRAND NEW cooling fans.
AC FANS Specify 240 or 110 v
 3" Fan dim 80 x 80 x 38 **£8.50 (B)**
 3.5" ETRI slimline 92 x 92 x 25 **£9.95 (B)**
 4" Fan Dim 120 x 120 x 38 **£9.95 (B)**
 As above TESTED RFE **Only £4.95 (C)**
 10" round x 3.5" Rotron 10v **£10.95 (B)**
DC FANS
Papst Miniature DC fans 62x62x25 mm Order **812 6-12v or 814 24v £15.95 (A)**
4" 12v DC 12w 120 x 120 x 38 **£12.50 (B)**
4" 24v DC 8w 120 x 120 x 25 **£14.50 (B)**
BUHLER 12v DC 62 mm **£12.95 (A)**
 1000's of other fans and blowers in stock CALL or SAE for more details.

SPECIAL INTEREST

Please call for availability or further info.
RACAL-REDCAL real time, colour drafting PCB layout system **£3950**
DEC VAX11/750 inc 2 Mb Ram, DZ, and full doc etc. **Brand New £8500**
HP7580A 8 pen digital A1 drum plotter with IEEE interface **As New £4750**
CHEETAH Telex machine **£995**
1.5 kw 115v 60 Hz power source **£690**
500 watt INVERTER 24v DC to 240v AC sine wave 50 Hz output **£275**
SOLDER SYSTEMS tin lead roller tinning machine for PCB manufacture **£350**
CALLAN DATA SYSTEMS multi user INTEL based UNIX system complete with software and 40 Mb Winchester disk drive. **£2750**
WAYNE KERR RA200 Audio, real time frequency response analyzer **£3000**
TEKTRONIX 1411/R PAL TV test signal standard **£690**
TEKTRONIX R140 NTSC TV test signal standard **£875**
HP 3271A Correlator system **£350**
PLESSEY portable Microwave speech / data link 12v DC, 70 mile range. The pair **£275.00**
19" Rack cabinets 100's in stock from **£15.00**

All prices for UK Mainland. UK Customers must ADD 15% VAT to total order value. Minimum order, cash £5, Credit Card £10. Official account orders from Government Depts, Universities, Schools & Local Authorities welcome - minimum account order value £25. Carriage charges (A) £1.50, (B) £3.50, (C) £6.50, (D) £8.50, (E) £10.00, (F) £15. (G) Call. All goods are supplied subject to our standard conditions of sale. All guarantees given on a return to base basis. We reserve the right to change prices & specifications without prior notice. Bulk trade & export enquiries most welcome.

MAIL ORDER & OFFICES
 Open Mon-Fri 9.30-5.30
 32 Biggin Way,
 Upper Norwood,
 London SE19 3XF

LONDON SHOP
 1000's of Bargains for callers
 Open Mon-Sat 9.5-3.0
 215 Whitehorse Lane,
 South Norwood, London SE25

DISTEL © The ORIGINAL
 FREE of charge dial up data base
 1000's of items + info ON LINE NOW!!
 300 baud 01 679 1888, 1200/75 01 679
 6183 1200 FDX 01 679 8769

ALL ENQUIRIES
01 679 4414
 FAX 01 679 1927
 TELEX 894502



SMART HOME CARDS

Roy Bright of Smart Card International coined the name "Smart Card" for its first international showing in 1980 and has been heavily involved in its world-wide commercialisation since then. He began his conference presentation with a brief look at the

Roland Moreno pioneered the technology and filed his first patents in the mid 1970s. Following the successful conclusion to trials by licensed suppliers in France, banks adopted the technology and, using Honeywell Bull's technology, implemented the new point of sale service using a "mixed card" comprising a magnetic stripe, microprocessor and an 8K memory. 16.4 million cards, plus associated reader etc,

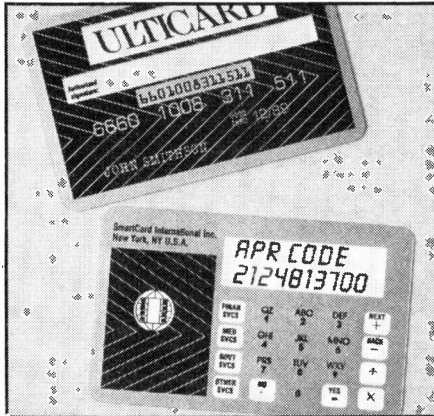

Ultracard - The ultimate in really smart cards. The same size and thickness as an ordinary credit card, but has microprocessor built into it providing high protection of security codes.

the term "smart". The microprocessor is used to control the various card functions as well as provide a variety of services, such as calculations, which can be programmed according to the particular needs of the application.

Applications to which the card can be put in the automated home are likely to be initiated by the building industry. The smart card industry itself is unlikely to take the initiative in this area, though many possible applications are foreseen. For example, it is likely that "smart homes" will be designed in which the various functions may be controlled via an active smart card. This would provide a set of easily comprehended prompts to guide the householder through a routine of keyboard entries to produce a master control program for the house, protected by the householder's PIN. Smart cards could be used for gaining access to the house and garage, for operating the

HOME AUTOMATION

were ordered for delivery over a three year period commencing 1986.

Meanwhile, Flonic Schlumberger was developing a pre-programmed card which, though less sophisticated, had the advantages of low cost, rapid development, and met ISO thickness requirements. Adopted by French Telecom for their Card-Phone service, 25 million cards have been supplied.

Prior to 1985, manufacturers had little choice but to use non-reprogrammable memory in their cards. With the greater reliability of eeproms, cards are now available with up to 64K of reprogrammable memory.

Conventional smart cards are passive, that is they can only be activated by insertion into a terminal having keyboard and display facilities, and capable of supplying power to the card. The high cost of terminals restricts the number of locations in which they can be placed, so restricting their convenience. To meet this problem, active cards are being developed, containing their own terminals and power source. They can be regarded as the "missing link" between passive cards and personal computers.

Effectively, an active smart card is a pocket-sized pc, but with the added benefit of being highly secure, while retaining compatibility with the interface standards for conventional smart cards. Like a pc, active cards have read-in, read-out facilities; use data-file structures with logical indexing; provide powerful processing features including scratch pad memory, and can communicate externally. Active smart cards are now currently marketed under the trade marked name of Ultracard, and have such diverse applications as welfare services, libraries, employment

**BY JOHN BECKER
PART TWO**

**THE LINE, THE SWITCH
AND THE AUTOMATED
WARDROBE.**

**Continuing our report
on how leading experts
regard the future for
home automation.**

seeking, cinema attendance, car parking and medical treatment. They are also highly suited to applications in an automated home.

Before considering suitable applications in the home, it is important to understand some of the unique features which could be exploited in this environment.

A major attribute of any smart card is its inherent security. First, the authentication of the card holder requires the correct Personal Identity Number (PIN) to be entered. Then the card is equipped to authenticate itself to the system before it is accepted as legitimate. It is important to note that the latter secret identity code never leaves the highly protected memory zone in the card. When challenged by the system, the card's microprocessor conducts the interrogation internally and transmits an encrypted response, so avoiding disclosure of the actual code outside the card.

These outstanding security features, and many others, are achieved by the card's embedded microprocessor. It is this which sets the smart card apart from other plastic card technologies and justifies the use of

alarm system, and for activating high value consumer items such as tv, video, hifi, etc. With the cooperation of equipment manufacturers this would be a major deterrent to burglars. Using a suitable home-based terminal, the enhanced security also allows for fund transfers in both telebanking and teleshopping, as the French are already discovering.

These innovations are unlikely to occur overnight, though an increasingly rapid proliferation of smart card technology is expected.

**DISPLAYS IN
TOMORROW'S HOME**

Peter Forster has worked for Philips Electronics for the past 24 years, occupying his present position as Strategic Planning Manager since 1984. During this time he has been an active member of NEDO Interactive Home Systems Task Force.

Displays are now an integral part of the home and 97 per cent of the 20 million homes in the UK have a tv, and many have more than one. This has implications for the family unit for the tendency is for the family to split into separate cells for discrete viewing.

In the simplest situation, ie, with entertainment, transmission is basically one way. Teletext represented an important step forward in that users can interactively search for external data when required. The integrated home systems concept takes us another stage further as the tv can now monitor sensors around the home and display their status or images on the screen.

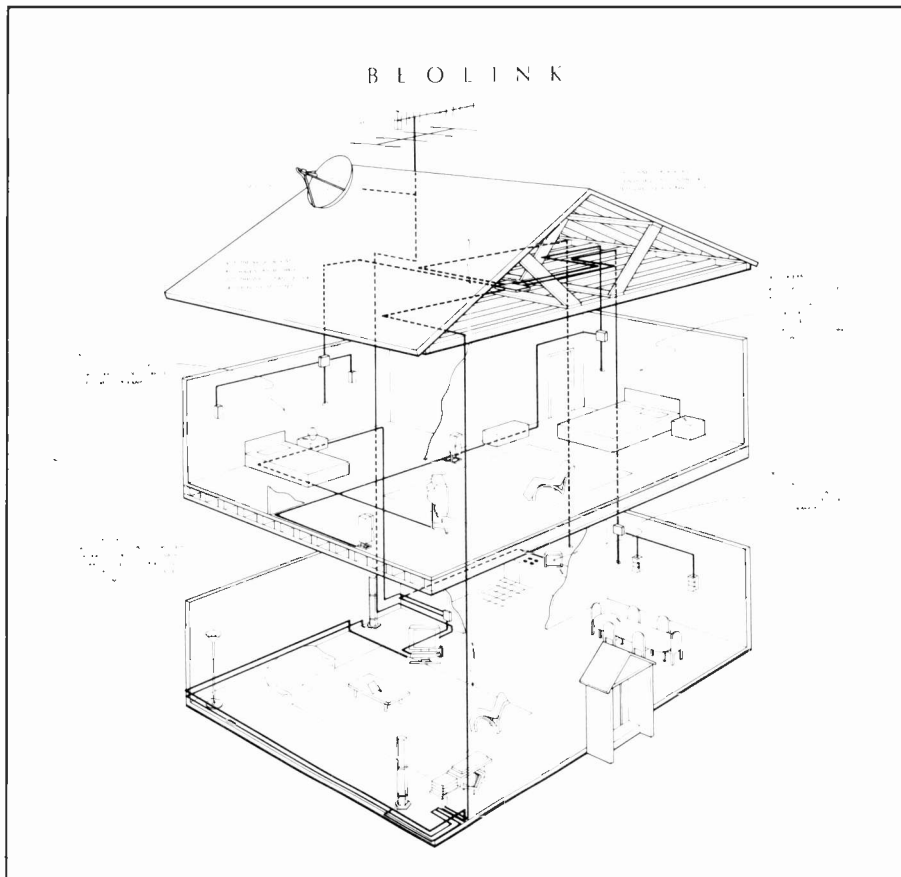

Fig.9. Bang and Olufsen's concept of a distributed sound and vision system

We can go on from that stage and build in other options allowing the user to remotely take action in respect of the displayed status.

LCDs could be dotted around the house at easily accessible points, such as at each light switch. Each room has at least one light switch and represents a convenient access point to a home data bus via existing or additional wires. It is technically possible to install sensors which determine the whereabouts of any person and activate an audio or video message according to locality.

HDTV is important in the context of automating the home. Pilot transmissions should start this year, and services start in 1992. The number of lines will double from 625 to 1250, the pixels will increase from 180,000 to more than 700,000 and further improvements will give strikingly detailed, clearer, crisper pictures. These improvements will make it possible to view much bigger screens. Today's screens still use the same format as in 1936, an aspect ratio of 4 by 3, but with hdtv the format will be 16 by 9. The extra width will make the format compatible with film so the screen will not cut off detail to either side as currently occurs in many instances. HDTV will also bring superb digital sound of cd quality, and surround sound to give cinema style effects in the home.

In the longer term we can expect further developments. As the use of optical fibres is

extended in cable tv, the extra bandwidth will allow an increase in the picture data transmitted. For example, picture in picture facilities with the home viewer able to zoom or shift images across the screen according to whim. The increased use of projectors for tv displays is another possibility foreseen, resulting in much larger images, projected perhaps onto the livingroom wall.

These improvements will only be beneficial if the consumer accepts their desirability. It is likely that consumers will be encouraged in this by the falling real costs of electrical goods, accompanied by an increase in functionality – a form of efficiency, since the equipment can do more. It has been calculated that had the same results been achieved in the automobile industry, the price of a Rolls Royce would be £3.75 and it would travel three million miles to the gallon!

DISTRIBUTED SOUND AND VISION

Keld Harder has worked for Bang and Olufsen for thirty years and is currently project manager of the Home Information Network project in which several large Danish companies participate. Though his comments relate specifically to Bang and Olufsen, other companies in the field have similar viewpoints.

"Give freedom to consumers to compose individual system solutions" is Bang and Olufsen's view. The Beolink system represents this philosophy, being a totally integrated audio/video system with distributed sound, picture and operation. (Photos).

It comprises a central audio/video system with which consistent high quality picture and sound equipment can be available in, and controlled from, every room in the house. The concept is an integration of data, control, sound and picture. Video signals are distributed through a coax cable, and data and sound are distributed via a shared 7-conductor cable. In order to ensure the consumer's simple use of the system, however complex, the number of buttons has been reduced to a minimum and made readily accessible. The user can also communicate with the system via infrared remote controls. The system is not restricted to entertainment purposes and it additionally allows control and monitoring of security and other home automation functions, plus a connection to the telecommunications network.

To ensure the widest possible perspective for Beolink, B&O entered into cooperation with several Danish companies, including one of the telephone companies. The collaboration has two objectives – to ensure that the products of individual firms are adapted to the home automation market, and to coordinate product developments so that they collectively form a total system comprising entertainment, information, telecommunications, teleoperation, energy control and security. With the additional cooperation of the Danish Ministry of Industry considerable finance has been invested in the "Handbook Project". This will contain guidelines on the design and implementation of home information networks so encouraging Danish industry to meet the requirements for complete automated homes.

INTERACTIVE VIDEO

Bryan Quilter is Chairman of National Interactive Video Centre Ltd, a government/industry supported organisation for the encouragement and development of interactive video in the UK. He presented a video in which several key points were made . . .

Interactive video brings together the power of the computer combined with the highest quality motion pictures. This unique combination has to date been expensive and more suitable for industry, education and institutions rather than the home consumer market.

Technical innovations can find early markets in one section and migrate to another. Computers reached the consumer in micro form after decades of development in industrial, scientific and similar

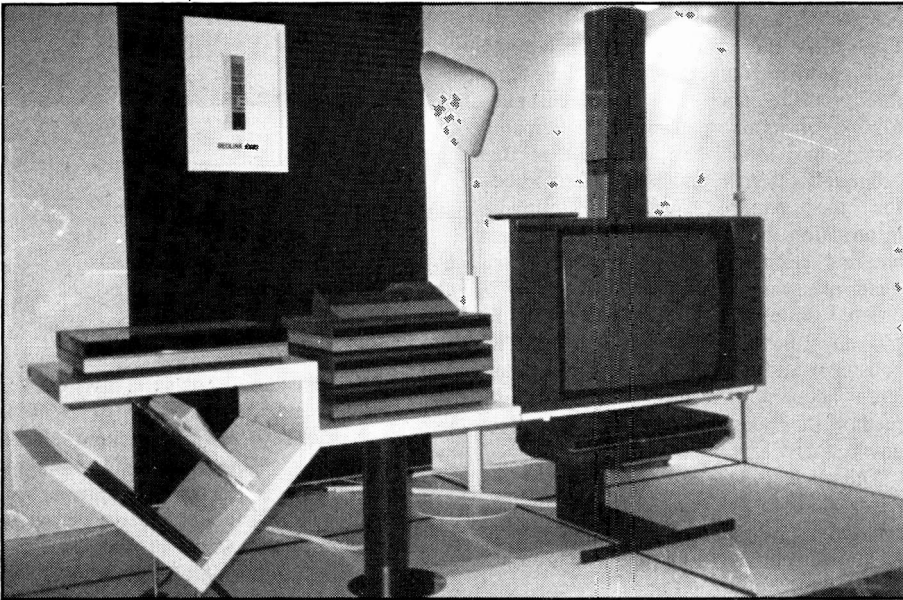

Products in Bang and Olufsen's interacting distributed sound and vision range

applications. Video travelled from consumer to industry. Technology is being transferred more widely and more quickly than previously. USA, Japan and Europe follow in quick succession. Standards battles may well be resolved at pre-competitive stages.

The key to the use of interactive video will be software. This could be entertainment, information or knowledge led and could reach the home from school or work. CDI is about to be launched and could be the first interactive visual medium for the home, if the performance and price expectations are realised. In any event the demand for IV software is very large and growing, and there is an immense opportunity for the UK.

At the training level, managers and government can solve many problems and potential problems by a bold and vigorous use of IV now. The benefits in the home will follow logically as the various elements fit into the market place.

HOME BANKING

Jonathan Reynolds is currently Research Fellow in Retailing at Templeton College, Oxford. He believes that the future of home banking in the long term can be said to be tied in with the future of consumer interactive services more generally.

According to a recent pronouncements by all the leading UK clearing bank retail banking directors, the future is not technology-led: "The nature of branches many well change. In the long term, there will be greater emphasis on self-service of all kinds and we will certainly see unmanned branches. But you cannot ignore the fact that the branch network is a very important sales force."

The future of home banking services using new technologies such as videotex, voice

synthesis and voice recognition has demonstrated two key advantages to those involved: greater accessibility and speed of control for consumers over their financial affairs: for the financial institutions a potentially drastic fall in the cost of paper-based processing. But the cost to the institutions and customers is still questionable - home banking using any of the newer technologies is an extraordinarily expensive capital investment.

Banks have been progressively moving towards automation since the 1960s, and "like old age, home banking is inevitable, but nobody wants to get there first". Using the home for banking affairs appears intuitively more attractive in the US than perhaps anywhere else in the world. In reality, the experience has been rather different. The estimate is that there are fewer than 80,000 subscribers to bespoke home banking services at present. The results are as yet inconclusive, and it might be said that the jury is still out.

In France it appears that the jury has been

rigged! As a result of considerable state subsidisation of videotex terminal distribution, one of the major cost barriers to the banks, the provision of terminal equipment in the home, has been largely overcome. At the end of 1987 there were some 850,000 customers of home banking services in France - one customer in 25 households.

Home banking in the UK has been characterised by early pioneering developments, followed by a disparate range of schemes and technologies advanced by banks and building societies. The lack of a large terminal population working to a common standard has prevented the kinds of scale economies and exponential growth of home banking services experienced in France - as it has prevented growth in other home-based teleservices.

Currently, home banking services in the UK are offered by the Bank of Scotland, Barclays Bank (pilot scheme for staff only), Clydesdale Bank, Lloyds Bank, Midland Bank (pilot scheme for selected customers only), Nationwide Building Society, Nottingham Building Society, Royal Bank of Scotland, and TSB/Speedlink.

When asked by Gallup in 1987 "which are you most likely to use computer shopping for?", 28 percent of UK respondents quoted banking affairs, second only to groceries. Popular support exists in principle for home banking, but a series of paradoxes dominate consumer issues in this area: consumers require the assurance of a secure system, but without the attendant complexity; they demand speed of access and interrogation of account information, but without the loss of the "float"; they demand a service at a low (or at no) cost, but one which is of high quality. These conflicts are not irreconcilable, but may be costly and complex for suppliers to introduce.

Despite some negative aspects, there are genuine opportunities for growth in home banking services, but as part of a broader strategy. It was never envisaged that home banking would ever replace conventional retail banking activities, but that it might enhance and complement it.



Examples of NEC's domestic controller units

HOME SHOPPING

Richard Poynder is Managing Director of Keyline Shopping Ltd. He described a unique concept in home service, which is being launched in the UK by Keyline in Autumn 1989. The company's product is an electronic communication system linking domestic consumers to wide variety of retail and financial services. The system comprises home terminals, an electronic delivery network accessed by a local telephone line, and a main computer system installed within the service provider's premises. Keyline was founded in November 1978 by Christopher Curry, co-founder of Acorn Computers and inventor of the BBC microcomputer.

Keyline consider that a home service should be seen as complementary to more traditional forms of shopping, and that three types of service are needed: shopping for and purchase of retail products – home shopping; acquisition of financial services – home banking; obtainment of useful information – home information. These services are needed 24 hours a day, seven days a week, and in the case of tangible goods, there needs to be an efficient delivery or collection service.

The objective is to distribute 2.5 million terminals to consumers and, through the participation of major retailers and financial institutions, to enable the consumers to shop for, compare prices of, order and pay for a large variety of products and services. The terminals are inexpensive to manufacture, portable, intelligent and able to be used by inexperienced operators –

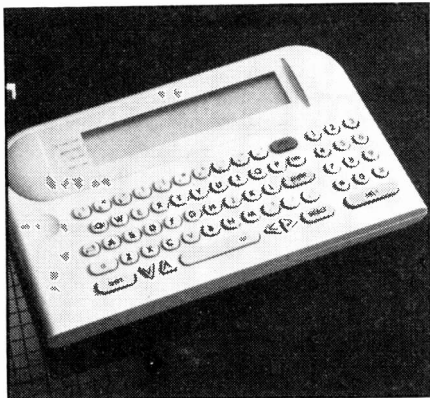

A keyline terminal – the hi-tech answer to shopping and information services every day of the year.

ordinary people in their own homes. The range of uses for the terminal when connected through the normal modern BT wall socket is almost unlimited – bounded only by the range offered by the service providers. The process of obtaining goods and services is intended to be simple, fast, convenient and cheap.

The terminal is battery-powered and

enables requests to be entered in simple English. At the right moment, the terminal will automatically connect the consumer, through the telephone line at local call rates, to one or more appropriate participating service providers. The customer is then prompted through the acquisition process for the required product, following information displayed on the terminal and entering simple English responses. Then, under password control, products can be ordered through the terminal, and paid for by any method agreed between the consumer and the supplier, eg. credit card, store account or current account. The method of goods delivery will also be by any mutually agreeable method.

Other facilities are offered by the terminal, both for local off-line use as a calculator, alarm clock, list storage, telephone number look-up, and for use connected to other domestic systems such as intruder or smoke detection devices.

Consumers may acquire the terminals at no capital cost, simply on application and payment of a small returnable deposit (around £35). They will then only need to pay for batteries (say 4 x AA batteries twice a year), and local telephone call charges for the time during which the terminal is on-line. Optional printers will also be offered to consumers, at a price of about £50.

The system has been designed specifically to protect consumers, retailers and financial institutions from fraudulent misuse. Features include both hardware and software tamper-resistance, as well as three levels of encryption depending upon the type of transaction being undertaken. User authentication will be by passwords issued secretly to users.

Fig.10. Comparison of building regulation standards in ten European countries using the Milton Keynes Energy Cost Indicator (MKECI)

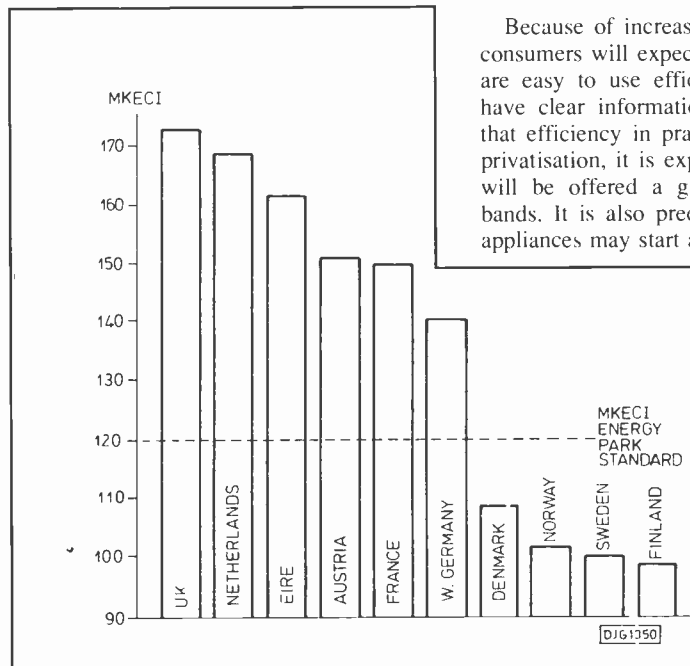

DOMESTIC ENERGY CONTROL

Brenda Boardman is an independent energy consultant who has researched into energy use in the home for the last six years and is a member of many related organisations.

The best known method of auditing energy is the Milton Keynes Energy Cost Indicator (MKECI), which is an index based on cost. Fig.4 shows the MKECIs for identical three bedroom, five person, end of terrace houses, if built in Britain to the standards of the present building regulations of ten European countries. The lower the MKECI the less energy is used – so Britain is the worst of the countries illustrated, and Finland the best.

In a typical house about 12 per cent of the energy comes from electricity, but this represents 40 per cent of the costs. Fig.5 shows the way in which electricity is used by appliances in an average house in north-west England, excluding heating and cooking. Fig.6 shows the electricity demand over a 24-hour period in England and Wales.

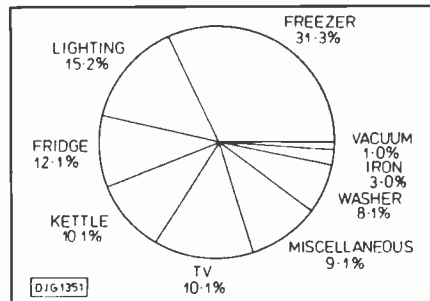

Fig.11. Electrical appliance consumption in an average house (excluding space/water heating and cooking)

Because of increasing energy awareness consumers will expect that their appliances are easy to use efficiently, and that they have clear information on how to obtain that efficiency in practice. With electricity privatisation, it is expected that consumers will be offered a greater range of tariff bands. It is also predictable that domestic appliances may start appearing with add-on

AUTOMATION FOR THE DISABLED

Elizabeth Fanshawe OBE DipCOT has been Director of the Disabled Living Foundation since 1983, and is a member of many organisations to do with improving the quality of life for disabled people. The Foundation is a national information resource on the non-medical resolution of the daily living problems facing the disabled.

The bulk of her remarks were addressed to the problems of disability as whole rather than to how automation might help the disabled. They were a chastening reminder that society has still not made adequate provision for the disabled in many areas. She made the point that due to the ageing process alone nearly all of us may become disabled in some way. A DoH survey shows that six million adults in Britain have disabilities. This is a large market to explore, even though the disabilities do not conform to a designer's ideal requirement for standardisation.

Initially, she pointed out, the mass market appliance manufacturers can help the disabled by ensuring that control knobs are of a size suitable to those with impaired grasp; that control legends and instruction documents have letters large enough for those with restricted vision to read and that they contrast well with their background.

She declined to give "a list of wizzy automated items that disabled people need because if such items are designed with the needs of ALL in mind they will be of just as much use to (the majority of) disabled people as they are to everyone else." Though she went on to say that the DLF can discuss various needs with interested companies, I was disappointed that at a conference of this calibre, to which the press were invited, she did not itemise and gain greater publicity for some of the less obvious applications for technology in aid of the disabled.

AUTOMATION FOR THE ELDERLY

Nigel Appleton is the Projects Director for the Anchor Housing Trust. His comments were largely related to defining old age and examining the economic situation for older people. He acknowledged that there is an undoubted role for automation and information systems in the field of specialised housing for the elderly...

To date the greatest penetration has been in communication and security systems. A major area of concern is the need to cope with increasing levels of frailty and confusion. Applications include supervision of residents, monitoring of self-administered medication, and control of mobility equipment. Many older people live alone or with one other elderly person, and are often at a distance from supportive family or friends. For the future their capacity to cope may depend upon a mix of human and technological support systems.

The problems are relatively basic. The need to control their environment, ie, heating and ventilation control and monitoring. The need for security and safety - alarm systems, smoke detectors and low temperature monitors. The need for communication - telephone and intercom systems, emergency call systems, computer banking and shopping. The need for low level support in personal care - activity monitoring, "vital signs" self-monitoring, and medication prompting. In all four areas the technology is already available and much of it is unsophisticated. The immediate future in this market lies not with new frontier technology but in the answers to two crucial problems: acceptability and affordability.

The resistance of older people to the acceptance of the new is probably no greater than for other age groups. But it may be that the way forward is to build on two pieces of equipment with which most older people are already familiar - the tv

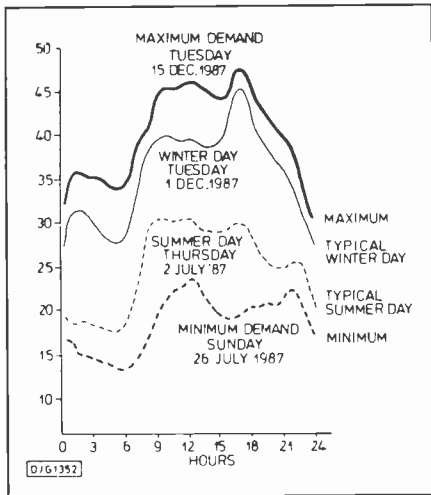

Fig.12. Electricity demand over a 24-hour period, England and Wales

displays showing the price of the present band to enable more precise energy management and establish which appliances could be switched off to save consumption during peak periods.

It is known that consumers value immediate control in central heating systems and gas central heating, the most responsive of systems, has continued to increase in popularity in all income groups (Fig.7).

Another force for change may come from increasing concern for the environment, both globally and within buildings. Such factors as depletion of the ozone layer and the greenhouse effect will have an impact on the techniques used to insulate homes and reduce energy consumption.

However, there are two other social factors that influence successful home automation. There can be considerable difficulties and expense involved in getting appliances repaired, consequently products must be reliable. Secondly, for products to be acceptable they must be as much designed for use by people with disabilities as for the able-bodied. Careful thought must be given to products intended for achieving energy efficiency.

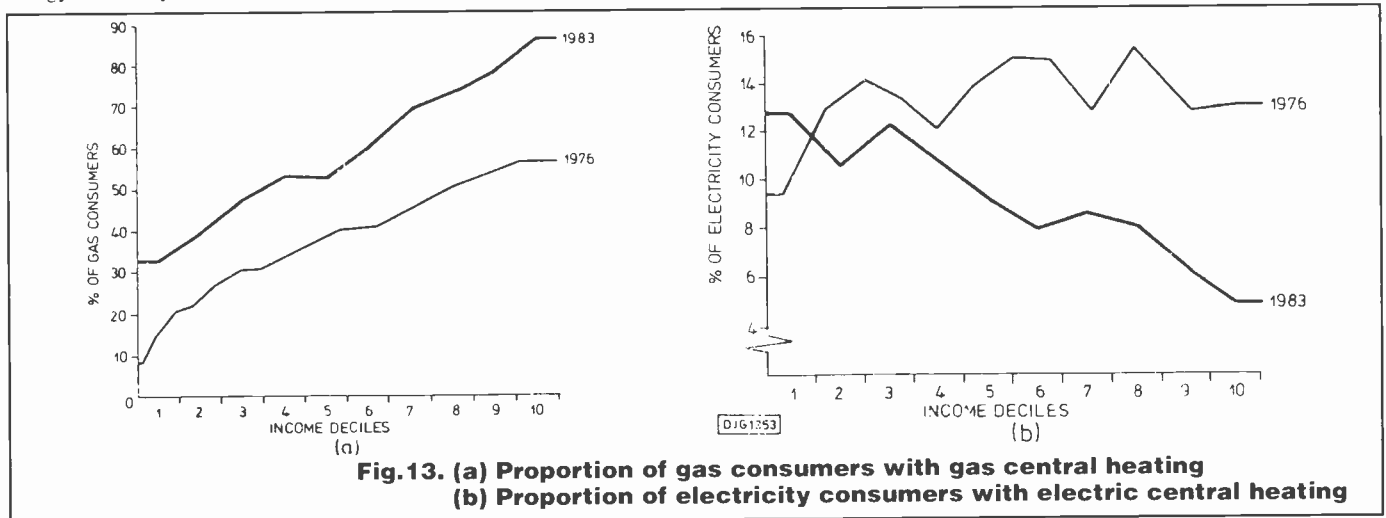

Fig.13. (a) Proportion of gas consumers with gas central heating (b) Proportion of electricity consumers with electric central heating

and the telephone. On affordability, there is the question of whether the market will be exploited solely for profit or whether there would be some intention of meeting need. The telephone is vital to the independence of elderly people, but many cannot afford it. Other systems and equipment which the majority of those who need them cannot afford will be seen as no more than rich geriatrics toys. Products and services must be affordable by a substantial number of those who actually need them.

There is a defined market for information and automation technology in specialised housing for older people. The greater challenge is in meeting the needs of the 95 per cent of elderly people who remain in their own homes. The need is for systems which will supplement or replace human support systems. Some needs and products are already identified but further product development is required and the future depends upon industry's ability to respond to the challenge of acceptance and affordability.

CONSUMER VIEWS

Dr Liz Mandeville joined RMDP's research department in 1985 and has been closely involved with the field of home automation. She has just completed a second programme of research on the same subject among consumers to establish their interests, attitudes, expectations, fears and concerns.

**TABLE 1
IMAGES OF THE AUTOMATED HOME**

Image	Attractive %	Unattractive %
Home-accessed facilities	58.5	14
Remote control	57	15
Armchair control	52	18
Programmable home	75	7
Robot aids	17	55
Automated furniture	24	52
Talking appliances	40	39

Table 1 shows the percentages of all participants who found the listed images attractive or unattractive. From the table it is apparent that the more "science fiction" images of robots and automated furniture are generally disliked, though opinion is divided on the merits of appliances capable of conversing with the householder.

This suggests that people like the idea of exerting greater control over their home, but don't like "gadgets". Fear was also expressed of a Sorcerer's Apprentice situation with unstoppable machines forever turning the tv on and off, pumping water, opening and shutting windows, and even answering back when told to desist. As it emerged in discussions, programmability is a double-edged concept: control is good in human hands, but extremely threatening when handed over to a machine.

**TABLE 2
APPLICATION AREAS: LEVEL OF INTEREST**

Area	Average Number of Mentions for Services
Household security	74.5
Energy management	67.5
Working from home	60
Financial services	54.5
Household management	53.5
Entertainment, education and culture	44.5
Health monitoring	41

Interestingly, the concept of home automation evoked certain initial responses, but attitudes changed when people began to consider some of the areas where home automation can be expected to have an influence. This is probably partly because it takes the subject out of science fiction or hobbyist atmosphere which tends to surround it – people began to think in detail how it might really affect their lives. Table 2 shows the levels of interest in particular areas as revealed by the number of mentions made during the discussions. The limited nature of this information is recognised.

**TABLE 3
MOST AND LEAST POPULAR APPLICATION AREAS**

Area	% of 'High' Responses	% of Low Responses
Entertainment, education & culture	37	3
Household security	23	–
Energy management	23	3
Financial services	7	9
Household management	7	13
Health monitoring	2	38
Working from home	1	34

Participants were asked to say which application areas they thought would prove most popular, and which the least. Table 3 shows the ranking order of the areas. The results indicate that there are clear winners and losers in the popularity stakes. Significantly, working from home, which has received a relatively large amount of publicity in discussions of home automation, fares very badly. (*Strangely, considering the current media coverage relating to healthy living, so does health monitoring. Ed*)

Discussions about who will benefit most from specific areas of home automation revealed the information in Table 4.

To assess participant's fears, the members of the groups were offered eight statements about home automation, each embodying a distinct attitude towards the subject, and asked which, if any, they agreed with. All except the last began "I think home automation ..."

1... represents progress in life styles. I look forward to its introduction.
2... is the latest fad, and will go the same way as other fads. I do not think it is something to take seriously.

**TABLE 4
WHO WILL BENEFIT MOST FROM HOME AUTOMATION?**

Area	Main Beneficiaries
Education, entertainment & culture	Everyone - 50% The young - 40%
Household security	Everyone - 48% The old - 26% The rich - 26%
Energy management	Everyone - 38%
Financial services	Everyone - 30% The rich - 40%
Health monitoring	Hypochondriacs/ health freaks - 33% The old - 29%
Household management	No particular pattern
Working from home	No particular pattern

3... has a lot to offer, but I am concerned about its implications for privacy and security of the home.

4... is likely to appeal only to technology enthusiasts.

5... is of great benefit to housebound and disabled people, but am not convinced that it has much to offer the population in general.

6... will change people's lives in ways we cannot yet foresee. I am concerned that many of the changes will be for the worse.

7... will make the task of running a home efficiently much easier and more cost effective. I welcome this development.

8... I regard the home as a private and relaxed place. I do not welcome the intrusion of high technology into the home.

Table 5 shows how participants responded to these statements.

**TABLE 5
ATTITUDINAL STATEMENTS ON HOME AUTOMATION**

Statement	% of Respondents agreeing
Look forward to progress	41
Unserious fad	8
Concerned about privacy & security	48
Only for enthusiasts	27
For housebound and disabled	52
Concerned about changes	47
Welcome household help	39
Intrusion on privacy	29

Fewer than a third of participants think home automation is only for high tech enthusiasts or worry about its intrusion into the home, and fewer than one in twelve consider that it is a fad which will go away. The highest support is for those statements which reflect uncertainty and reservation. The task of companies entering this market will be to identify and address major areas of concern, so that their products may be received as helpful rather than threatening. This research is designed to help with that task.

Both as PE's Editor and as an interested individual, I would have additionally liked to know the social and age groupings of the participants in relation to their answers.



TOTAL CONTROL

Colin Blake describes himself as an automated home owner! Like many PE readers, he loves inventing, making and installing almost anything electronic or mechanical that takes his fancy. What he has designed for his home holds many possibilities for the advancement of future living.

Home automation has the ability to allow people to lead a more organised, secure and stressless lifestyle. It also has a novelty factor – capability to control appliances that most of us regard as only suitable for human intervention.

Automation of the home has a personality extension – to some people their image must be reflected in the home and they draw inspiration from the James Bond examples so much admired on the screen. The entertainment world has been prone to showing home automation in a negative light – gaining humour from situations where automation goes wrong. The real world is not usually like that – if automation constantly went wrong no-one would buy washing machines, toasters and other electro-mechanical devices.

I started automating my home by installing infrared light controllers, adjustable lampshades, video cabinet with opening doors and sliding table, and provided the windows with electric curtains! It was soon apparent that each

function needed separate controllers and that finding the appropriate one took longer than manually performing the same function. The implementation of a single master controller was the next objective.

Demobbing the home computer from the space-wars front, I built an interface, wrote software and converted the system to generate patterns of control sequences for lights and curtains. But it was limited – freedom of control was needed, a method of communicating with the computer that didn't restrict access.

The humble telephone – that was the answer, a means of communication from almost anywhere to the home. A second interface was built linking the phone to the computer via dtmf (dual tone multifrequency) across a conventional voice link. A dtmf tone pad placed over the handset would send coded data to the computer, which would reply with menus and prompts generated by digitally assemble human voice. In 1987 the next module was built, and control of a table lamp in the living room became telephone active!

Currently I have control of central heating, hot water, house lighting, curtains and what must be a first – an underground plumbed sprinkler system to water the lawn. And all controllable at any time of day from anywhere in the world by the push of a button over the telephone.

May that be inspiration to all PE readers!

PE

REFERENCES

- Anchor Housing Trust**, 0865 311511. Nigel Appleton.
Bang and Olufsen, 0452 307377. Bob Stockwell.
BBC Engineering, 01-927 5432. David Lees.
Brenda Boardman, 0273 472029.
British Telecom Research Laboratories, 0473 643210. Keith Clarke.
Disabled Living Foundation, 01-289 6111. Elizabeth Fanshawe.
IBA, 04893 2130. Walter Anderson.
Institute of Economic Affairs, 02406 3128. Keith Miles.
Keyline Shopping Ltd, 0480 87464. Richard Poynder.
National Economic Development Office, 01-211 3100. Barbara Stephens.
National Interactive Video Centre Ltd, 01-387 2233. Bryan Quilter.
NEC, 01-993 8111. Keith Yassui.
Oxford Institute of Retail Management, 0865 735422. Jonathan Reynolds.
Philips, 01-580 6633.
Phone Control Services, 0527 46545. Colin Blake.
RMDP, 0273 722687. Liz Mandeville.
Science Policy Research Unit, 0273 686758. David Gann.
Smart Card International, 0689 78345. Roy Bright.
Thorn-EMI, 01-848 9779. John Ryan.
We are grateful to RMDP for their kind permission to publish summaries of the information presented at the conference



★ LEARN BY BUILDING ★ ENJOY BY USING ★

PROJECT KITS

★ BE CREATIVE ★ RAISE YOUR SKILLS ★ GET KITTED! ★

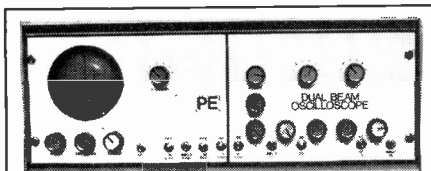

DUAL BEAM OSCILLOSCOPE

2Y-amps, 6 ranges, variable level, DC to over 1MHz. 4 modes – Y1, Y2, Y1 & Y2, Y1 & Y2 to X. Time base variable from 0.05Hz to 20KHz. Variable sync level, polarity and source. Separate bright-line, brilliance and focus controls. Independent trace deflection controls. Details in catalogue.

BURGLAR ALARM CONTROLLERS

MULTIZONE CONTROL SET280

£23.90

Two entry-zones, anti-tamper loop, personal attack, entry-exit timing, timed duration, automatic resetting, latching LED monitors.

SINGLE ZONE CONTROL SET279

£10.50

With timed duration control and latching LED monitor. Both units can be used with any standard detection devices, such as contact or magnetic switches, pressure pads, tremblers, ultrasonics, infrared etc., and will activate standard bells, strobes or sirens.

COMPUTER KITS

The software listings published with the computer kit projects are for use with C64, PET and BBC computers.

CHIP TESTER SET258F £41.50

Computer controlled logic and chip analyser.

EPROM PROGRAMMER SET277 £26.20

Computer controlled unit for 4K Eproms.

MICRO-CHAT SET276 £69.50

Computer controlled speech synthesiser.

MICRO-SCOPE SET247 £49.50

Turns a computer into an oscilloscope.

MICRO-TUNER SET257 £57.40

Computer controlled, tuning aid and freq counter.

MORSE DECODER SET269 £26.70

Computer controlled morse code-decoder.

**MORE KITS IN CATALOGUE
SEND MEDIUM S.A.E. FOR CATALOGUE AND
WITH ALL ENQUIRIES
(OVERSEAS SEND £1.00 TO COVER POSTAGE)**

VARIOUS

VOICE SCRAMBLER SET287 £49.50

32 switchable channels to keep your communications confidential.

STORMS! £35.50 each unit

Raw nature under panel control! Wind & Rain SET250W. Thunder & Lightning SET250T.

DISCO-LIGHTS SET245F £69.50

3 chan sound to light, chasers, auto level.

EVENT COUNTER SET278 £36.60

4-digit display counting for any logic source.

ASTRONOMY

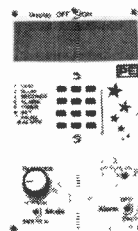

SIDEREAL CLOCK SET295

£49.50

Dual purpose star-time and solar-time digital clock with alarm.

ENVIRONMENT

WEATHER CENTRE

Keep the Met Office in check and monitor the wind speed and direction, rain, temperature, soil moisture and sunny days.

Six detector circuits – KIT 275.1 £18.50

Automatic metered control monitor circuit – KIT 275.2 £41.50

Optional computer control circuit – KIT 275.3 £15.50

ELECTRONIC BAROMETER SET285

£41.20

Computer controlled unit for monitoring atmospheric pressure.

GEIGER COUNTER SET264 £65.50

A nuclear radiation detector for environmental and geological monitoring. With built in speaker, meter and digital output. This project was demonstrated on BBC TV.

ORDERING

Add 15% VAT. Add P&P – Sets over £50 add £3.00. Others add £2.00. Overseas P&P in catalogue. Text photocopies – Oscilloscope £3.00, Geiger £3.00, Weather £2.00, others £1.00, plus 50p post or large SAE. Insurance 50p per £50. MAIL ORDER, CWO, CHQ, PO, ACCESS VISA. Telephone orders: Mon-Fri, 9am – 6pm. 0689 37821. (Usually answering machine).

PHONOSONICS, DEPT PE95, 8 FINUCANE DRIVE, ORPINGTON, KENT, BR5 4ED.

MAIL ORDER

HIGH GRADE COMPONENT PARCELS

Unless otherwise stated, all the clearance parcels we offer contain brand new, top grade components. If some of the offers look too good to be true, all I can say is that the optimists will get some stunning bargains, the cynics will never know what they've missed, so everybody will be happy! All offers apply only while current stocks last - watch out for next month's parcels or, better still, be the first to hear about any new offers by putting your name on our mailing list. (Please write in, or phone Pete Leah on 0272 522703 after 6.30 pm).

EVERYTHING MUST GO!

UNIVERSAL EVERYTHING PARCEL

This one contains some of just about any component you care to name! There are passives (resistors, capacitors, tants, presets), opto devices (couplers, LEDs of all shapes and sizes, infra-red components, 7-segment displays), semiconductors (transistors, diodes, ICs, rectifiers), and all kinds of other odds and ends (relays, VDRs, neons, battery connectors, mixed components packs). A stunning range of components - enough to get a workshop or lab started - at a ridiculously low price.

The components are of excellent quality, in packs originally intended to sell at £1 each. To make sure you get a good variety, the 20-pack parcel will have no more than two of any one pack, the 100 pack parcel will have at most five of any one pack. Packs supplied as they come - our choice.

PARCEL 1A: 20 PACKS for £10 + VAT
PARCEL 1B: 100 PACKS for £39! + VAT

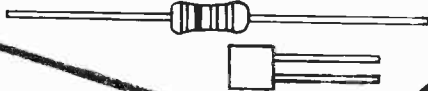

MASSIVE CLEARANCE SALE

Once again, a general purpose parcel containing a huge variety of components: resistors, capacitors, ICs, transistors, electrolytics, tants, triacs, LEDs, diodes, thermistors, trimmers, VDRs, all sorts. All new, top quality components. This is mostly remainders from our own stock - stuff we forgot to advertise, or have in too small a quantity to sell individually. Guaranteed to be worth at least eight times the price if valued from any standard component catalogue! What more can I say?

PARCEL 2A: 1000+ top grade components for £12! + VAT (Value £100+)
PARCEL 2B: 5000+ top grade components for £49! + VAT (Value £500+)

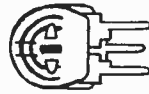

INTEGRATED CIRCUITS

This parcel contains nothing but ICs. The mixture offers TTL and CMOS logic, interface ICs, linear, data converters, op-amps, special functions, and so on. Some of the ICs are pre-packed with data sheets, some (TTL, CMOS, op-amps) we expect you to identify for yourself, others will be covered by the free *data pack* provided, and the rest you'll have to identify under your own steam. If you know your ICs you'll be in for a few nice surprises.

PARCEL 3A: 100 ICs for £12! + VAT
PARCEL 3B: 500 ICs for £49! + VAT

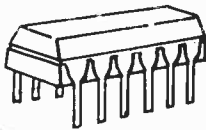

TANTALUM CAPACITORS

A nice range of tants in values up to 47µF. Lots of useful caps, and we're not mean with the most expensive ones. A fine selection.

PARCEL 4A: 100 TANTS for £6.80 + VAT
PARCEL 4B: 500 TANTS for £29! + VAT



LEDs

All shapes, sizes and colours of LEDs. Round ones in various sizes, rectangular ones, red, green, amber and yellow ones, clear and tinted lenses, all sorts.

PARCEL 7A: 100 LEDs for £5.90 + VAT
PARCEL 7B: 500 LEDs for £24.90 + VAT

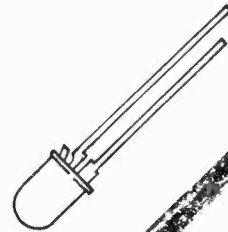

ELECTROLYTICS

A first class selection of good, modern electrolytics. The mixture ranges from small coupling caps up to huge power supply electrolytics - you'll be hard pressed to find any value between 1µF and 2200µF that isn't represented. A wide range of very useful components. Go for it!

PARCEL 5A: 1000 ELECTROLYTICS for £8 + VAT
PARCEL 5B: 2500 ELECTROLYTICS for £16 + VAT



TRANSISTORS

A mix of general purpose silicon transistors, mostly bipolar NPN and PNP, with a few FETs and unijunctions thrown in (when available) to spice the mixture. The contents vary from month to month - at the moment there are BC212s, BC213s, BC548s, BC238Bs, MTJ210s, and so on. Next month - who knows? All top quality components.

PARCEL 6A: 200 TRANSISTORS for £7.80! + VAT



CAPACITORS

An exciting selection of capacitors. There are ceramics for decoupling and general use, Polystyrenes for high performance circuits, dipped and moulded polyesters in values from a few nF up to 2.2µF (very expensive!), tants and aluminium electrolytics - just about any capacitor you'll ever need. Don't miss this one!

PARCEL 8A: 1000 CAPACITORS for £6.50 + VAT

PARCEL 8B: 2500 CAPACITORS for £14.90 + VAT

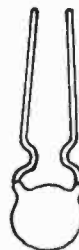

HIGHGRADE COMPONENTS LTD

Unit 108, 8 Woburn Road, Eastville, Bristol BS5 6TT

UK Orders:

Please add £2.50 towards postage and packing and 15% VAT to the total

Europe and Eire:

Please add £6.00 carriage and insurance. No VAT

Outside Europe:

Please add £12.00 carriage and insurance. No VAT

Test gear is an important part of any engineer's toolkit and, like any other tool, having the right pieces of test gear can save a lot of time. The quality of gear is important, too. Ever tried using a soft-metal screwdriver?

One of the most fundamental items in the toolkit is the meter. A few years ago, the meter would almost certainly have been an analogue one. Now the most common type seems to be the digital multimeter. Originally, these were expensive and were only seen in professional use. However, they have dropped in price and are now easily afforded by the keen amateur.

Choosing which meter you want to buy might seem like a simple task – but as you delve into the jargon you might discover that meters, analogue and digital, have a lot more to them than meets the eye. Some modern digital meters can appear to be very complex – but is the complexity worth it?

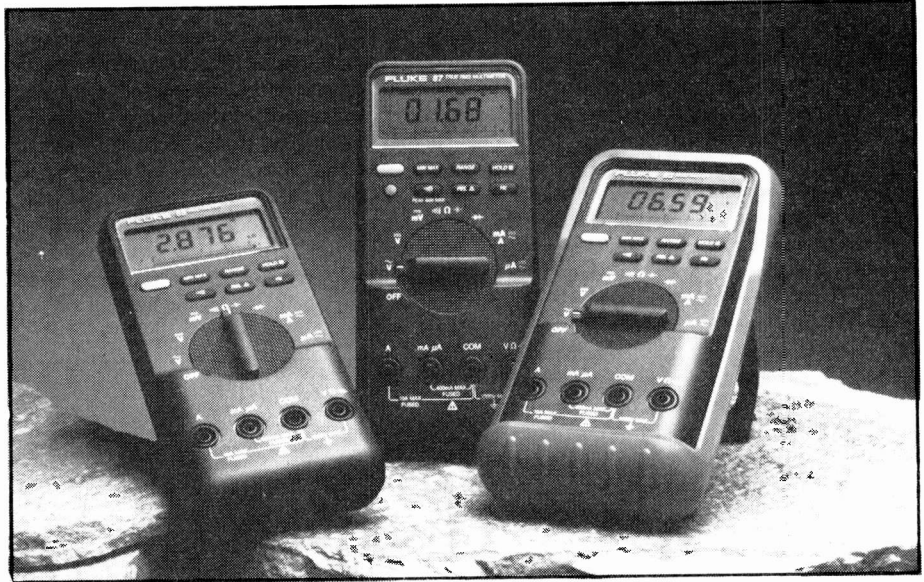

DIGITAL MULTIMETERS

BY SAMUEL DICK

There are three quick reasons why, in most instances, a digital meter is better than an analogue meter. The first of these is accuracy. Accuracy is usually expressed as a percentage of the value read plus or minus one or two digits. For measuring dc voltages, a manufacturer might specify $\pm 0.3\% + 1$ digit. This means that if we were measuring, say, 2Vdc the error would be $(2 \times (0.3/100)) = 0.006V$ from the first part of the specification and to this 0.006V we would have to add 0.001V if we were using a "3 1/2" digit meter on, say, a 4 volt scale.

WHY DIGITAL

By a 3 1/2 digit meter, the manufacturer means that the meter will display three digits with 0 and 9 capability but there will be another digit which will only be able to display 0, 1, or 2 (typically). Hence, the meter will read from 0000 to 2999 but the exact range covered will depend on which range is selected by the user. So it might be 0.000 to 2.999Volts or 00.00 to 29.99 mA or 000.0 to 299.9 Ohms. The decimal point can move around to accommodate different ranges.

This level of accuracy is far above what analogue meters can manage – typically a few percent accuracy. But be careful. If you use a 000.0 to 2999.9 mA range to measure a current of only 3 mA then the digital meter's accuracy will fall. Using the same specified accuracy as above, 0.3% of 3mA is 0.009mA. Remember that we have to add the "1 digit" (which is always the least significant). The accuracy is now 0.009mA plus 0.1mA which represents 3.6% of the reading. So with a digital meter you have always to remember to use the most

Digital meters don't do magic, but they can do some tricks that analogue meters find hard to match, and are increasingly applicable to today's developments.

sensitive range which will cope with the quantity being measured.

The next advantage of a digital meter is the resolution. If you have to measure small fluctuations in a constant signal then the higher resolution will enable you to see the changes where small movements of a panel meter's needle would never be spotted.

The digital meter converts the analogue signal from the test-prods using an analogue-to-digital converter (adc). The output of the adc is then fed to the meter's display. With higher quality meters, better adc are used and so a higher accuracy and a 3 1/2 digit resolution might be offered; a £300 meter might well have an accuracy of 0.05% and 4 1/2 digits.

Increasing cost will bring other advantages – more later!

The third 'quick' reason for buying a digital meter is that the adc will have a very high input impedance. Good digital meters have an input impedance of at least 10

megohms – some up to 10 gigohms! This high impedance means that the meter will not, under most circumstances, load the circuit which it is measuring. For accurate measures of voltages this can be very important: placing a low-impedance meter across a component can have the effect of shorting it out! Good analogue meters typically have an impedance of 20k ohms per volt – so on a 3V range a 60k resistor is placed across the circuit under test.

There are circumstances where this value of resistance in parallel with the circuit under test will seriously affect the reading being taken. Take, for example, a simple voltage divider consisting of two 100k resistors in series. The voltage at the mid-point will be half the supply voltage – except when you place the meter in the circuit. Then the voltage read will be just over a quarter of the supply voltage! With a good digital meter the error will only be 0.5%.

TRUE OR AVERAGE?

One major difference between analogue and digital meters is their ability to offer "true rms" or "average" readings – meters seem to come in the two types so it is an important point to get right. But what does it all mean?

The term "average" means that the meter measures the average value of the ac voltage or current. A "true root-mean-square" meter measures the effective heating value of the signal being measured.

In many cases there is little difference. Since wave signals give the correct reading regardless of the type of meter used: slightly distorted sinewaves will give

readings which may be only a few percent in error. However, ac waveforms which are spikey – like current from a rectifier or a voltage controlled by an scr or triac (eg. a light dimmer circuit) – can be wrong by some tens of percent if measured with an averaging meter.

If you need a true-rms meter then there is another choice waiting for you. Because the meter has to respond to rapid spikes in signals, the meter's adc unit has to be designed to cope – and it will only do so up to a certain frequency. Averaging meters and lower priced true-rms meters will give readings accurate to a few percent with signals having frequency components up to 1 or 2kHz. Medium-priced true-rms meters will respond accurately to, say, 30kHz; the better quality meters can be used up to a few hundred kilohertz with only a small percentage error.

This may seem exotic but if you are trying to measure noise in audio equipment or low frequency digital signals then a response up to 200kHz will ensure that you measure a significant number of the harmonics which the signal is likely to contain.

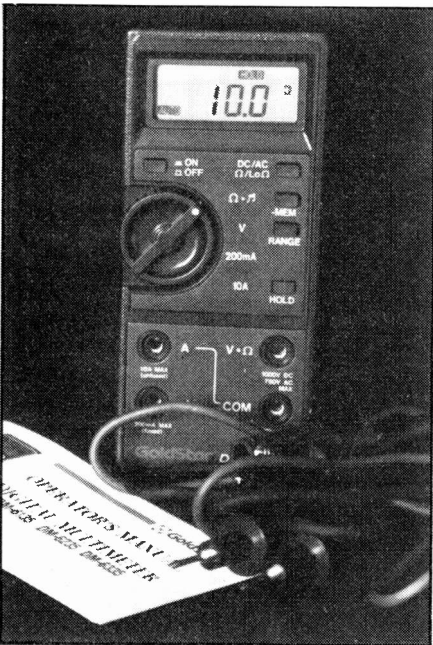

A manufacturer will also state the crest factor with which the meter can cope. This factor is simply the ratio of the peak voltage to the root-mean-square voltage of the signal; typically a crest factor of three can be accommodated.

MORE AND HIGHER

All meters have their limitations. Perhaps the maximum ac current that can be measured is only 2 amps. This is not enough to test many domestic appliances and certainly not utility or commercial circuits where current up to a few thousand amps can be found.

Current limitations can be overcome by

using a shunt for low-current work. The shunt is just an accurate low-value resistance which is placed in parallel with the meter and takes most of the current. These can be used up to around 20 amps. If higher currents are to be measured, a clamp probe should be used. With these probes, you do not have to break the circuit whose current you want to determine; normally a meter has to be placed in series with the circuit under test and requires a break to be made somewhere – with the current off, of course!

circuits – special probes prevent the high voltage leaking up into the unwitting user. Normal meter probes would not be safe at these voltages.

BITS AND PIECES

Voltage and current measurements are the main uses to which meters are put. But there is also the need to measure resistance – and digital meters cope well here, too.



With a clamp probe, the probe just snaps round a conductor – which might be a few centimeters in diameter – and uses the magnetic field generated by the current to couple into either a pick-up coil (for ac only use) or a Hall-effect device; Hall effect devices can be used on ac or dc circuits.

Measuring high-frequency circuits is a problem familiar to the amateur. While many amateur radio books have details of build-your-own hf probes, you can also obtain them ready-built with responses up to near 1GHz!

TV service engineers and valve enthusiasts will be aware of the dangers of taking measurements on high voltage

They also offer a simple diode test facility and a continuity beeper. The extra accuracy can be useful when building audio filters. Often, filter designs call for 1% components – which tend to be expensive. By checking components in stock, items within the tolerance range required can sometimes be found.

If you find yourself testing cables or circuit continuity often then look in the manufacturer's specification to see if a fast continuity check is offered – some digital meters can take well over a second to signal that continuity is okay.

One completely new field for meters is that of measuring frequency. This was a feature which was never incorporated into analogue meters – but since a lot of digital logic is inside a digital meter it was a little step to make frequency measurements possible. Typical handheld meters can measure up to around 200kHz – very useful if you are testing tone-generating circuits like modems or afsk communications equipment.

Linked with frequency measurement as a new feature is capacitance measurement. This is a rare feature so remember that a resistor and capacitor voltage divider fed with an ac signal of known frequency can help you find the value of a capacitor.

Finally one of the greatest time savers must be the ability to leave the meter watching for the minimum and maximum values that it measures in a circuit – saves waiting for that intermittent fault to happen! So if this is a frequent task, get a meter with a min/max hold facility. Similarly, a touch-hold feature which allows you to set-up the



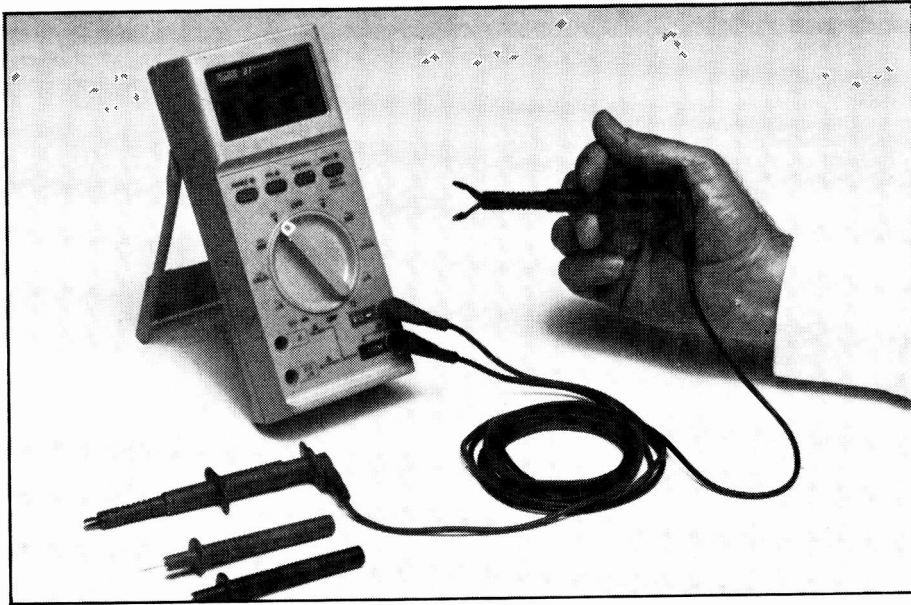

meter to the right range, briefly place the probes on the circuit, take them off and only then look at the meter to see what the reading was. This is a real boon. How often have you dared a glance at the meter and prayed that the test probes do not slip? **PE**

METER PHOTOS

We had asked our regular advertisers if they would care to send photos of any meters they stocked. All agreed, but at the time of going to press only Cricklewood Electronics, 40 Cricklewood Broadway, London NW2 3ET, had obliged, to whom our thanks for the photo at top right (model 6010). The other photos show newly released

meters and were received as part of publicity material detailing new products. In order of photo appearance further information can be obtained from:

Philips Test and Measurement, York Street, Cambridge, CB1 2PX (reference Fluke Models 83, 85, 87). Alpha Electronics, Unit 5, Linstock Trading Estate, Wigan Road, Atherton, Manchester M29 0QA (reference Gold

Star Model DM 6335). Electronic Temperature Instruments, PO Box 81, Worthing, Sussex BN13 3PW (reference Model DM 4351). Instrument Rentals, Dorcan House, Meadfield Road, Langley, Berks, SL3 8AL (reference Model PM 2525). Philips Test and Measurement, York Street, Cambridge, CB1 2PX (reference Fluke TL 20 Test lead set and meter model 27).

PCB DESIGNER FOR THE 48K ZX SPECTRUM

Now you can produce high quality printed circuit boards/circuit diagrams/component layouts on your 48K ZX Spectrum. If you don't own one it's worth getting one just for this suite of programs! Comprehensive manual included with getting started tutorial.

FULL SUITE FOR ONLY £30.00 INC.

PCB LAYOUT:

Produce quality printed circuits directly from your EPSON RX/FX or compatible dot matrix printer using a dense 1:1 printout on positive photoresist coated board. Or super quality using x2 printout and photoreduction. Many features such as 15 track widths; 15 pad sizes; 16 transistor/corners; 20 connectors; large multiscreen WYSIWYG display gives a clear uncluttered view of pads, tracks and drill holes; 0.1in. grid on/off; Block move; copy; mirror; rotate; erase; area fill (ideal for earth plane); preview; undo; dimensionally accurate printer routine with quick print; 1:1 or 2:1 dumps Custom pad design and library. Available separately for £20.00 inc.

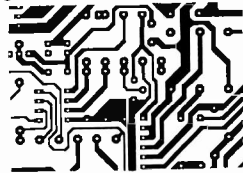

COMPONENT LAYOUT

Draw component layouts directly or from existing pcb layouts using a unique track reducing facility. The following components are provided: resistors, capacitors, ics, diodes, transistors, line drawing, printout and block commands as above. Not available separately.

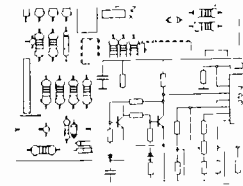

CIRCUIT DIAGRAMS

Features similar to the above programs with a library of electronic symbols including resistors, capacitors, diodes, transistors, fets, op amp, switches, inductors, logic gates. Not available separately.

Version now available for EE Centronics Interface - see Jan issue State version required from: Disciple/+D; Discovery; +3; Microdrive & Tape. Important! Tape and Microdrive users please state Centronics interface in use or send £1 for details.

KEMSOFT THE WOODLANDS, KEMPSEY, WORCESTER WR5 3NB. Tel. 0905 821088 after 6 p.m., or see us on A.I.X-386 BULLETIN BOARD 0905 52536/754127 on any computer with modem.

<p>OSCILLOSCOPES</p> <p>TELEQUIPMENT D83 Dual Trace 50MHz Delay Sweep. Large Tube. With Manual £350</p> <p>COSSOR OSCILLOSCOPE CDU150. Dual Trace 35MHz Delay Sweep. Solid State Portable 8 x 10cm Display. With Manual. NOW ONLY £180 each</p> <p>Optional Front Protection Cover containing 2 Probes & Viewing Hood. £18</p> <p>SCOPEX 4010 Dual Trace 10MHz With Manual £150</p> <p>S.E. LABS SM111 Dual Trace 18MHz Solid State Portable AC or External DC operation 8 x 10cm display with Manual £150</p> <p>TELEQUIPMENT D43. Dual Trace 15MHz. With Manual £100</p> <p>TELEQUIPMENT S54A. Single Trace 10MHz. Solid State. With Manual £90</p> <p>GOULD/ADVANCE OS255 Dual Trace 15MHz. With Manual £225</p> <p>ADVANCE OS250TV. Dual Trace 10MHz. With Manual £150</p> <p>SCOPEX 456 Single Trace. 6MHz. With Manual £65</p>	<p>SPECIAL OFFER AT ONLY £300 EACH</p> <p>TELEQUIPMENT D755 (MATO approved version of D75) DUAL TRACE. Delay Sweep. 50 MHz.</p> <p>TRIO RF SIGNAL GENERATOR Type SG402 100KHz-30MHz. Unused (P&P £7) ONLY £75</p> <p>COLOUR BAR GENERATOR Type PAL MC-101. 8 patterns Pocket Size. Rechargeable batteries. Complete with Battery Charger/Main Adaptor. Unused (P&P £4) ONLY £90</p> <p>COLOUR BAR GENERATOR Type PAL MC321. 8 patterns Video/Sound Output. Unused (P&P £7) ONLY £175</p> <p>LABGEAR FIELD STRENGTH METERS £80 (P&P £7)</p> <p>DECCA Colour Bar Generator type B2514. £125</p> <p>PHILIPS COLOURBAR GENERATOR type 5508. Video out. Many functions £150</p> <p>Labgear Colour Bar Generator KG1 8 Test Patterns. (P&P £4) ONLY £40 each</p> <p>ADVANCE SG62B. AM. 150KHz-220MHz £45 (P&P £7).</p>
<p>MULTIMETERS</p> <p>AVO 8 Complete with Batteries & Leads From £45</p> <p>AVO 8 MKV Complete with Batteries & leads £90</p> <p>AVO TEST SET No 1 (Military version of AVO 8) Complete with batteries & leads £65</p> <p>TEST LEADS suitable for AVOMETERS. Red & Black with 2 Croc. Clips & 2 Prods. (p&p £3) £5</p> <p>Black "Ever-Ready" case for AVOs. Unused (P&P £4) £20</p> <p>LABGEAR CROSSHATCH GENERATOR Type CM6038-DB Crosshatch/Grey Scale/Blank Raster. Mans or BATTERY. Unused £18. Used £12 (P&P £3)</p> <p>Marcconi AF Power Meter TF893A 20Hz-35KHz 20MW-10W with Manual. (P&P £7) ONLY £35</p> <p>Marcconi RF Power Meter TF1152A/1 DC-500MHz 0.5 to 25 Watts 50 ohm with Manual. (P&P £7) ONLY £45</p> <p>MARCONI ATTENUATOR TF2162 DC-1MHz 600 ohm 0-111 Db in 0.1 Db steps. (P&P £7) £35</p> <p>HATFIELD ATTENUATOR DC-250MHz 50 ohm 0-100 Db. (P&P £4) £60</p>	<p>AVO TRANSISTOR ANALYSER MK 2 (CT448) Suitcase style Complete with batteries & operating instructions. ONLY £25 each (P&P £7)</p> <p>AVO VALVE TESTER CT160. Suitcase style. 22 Bases. (P&P £7) ONLY £25 each</p> <p>NEW EQUIPMENT</p> <p>HAMEG OSCILLOSCOPE 604. Dual Trace 60MHz. Delay Sweep. Component Tester & 2 Probes £575</p> <p>HAMEG OSCILLOSCOPE 203.6. Dual Trace 20MHz. Component Tester & 2 Probes £314</p> <p>All Other Models Available.</p> <p>BLACK STAR FREQUENCY COUNTERS P&P £4</p> <p>Meteor 100 - 100MHz £99</p> <p>Meteor 600 - 600MHz £126</p> <p>Meteor 1000 - 1GHz £175</p> <p>BLACK STAR JUPITOR 500 FUNCTION GENERATOR. Sine/Square/Triangle. 0.1Hz - 500KHz. P&P £4 £110</p> <p>BLACK STAR ORION. PAL TV/VIDEO COLOUR PATTERN GENERATOR £199</p> <p>HUNG CHANG DMM 7030. 3 1/2 digit. Hand held 28 ranges including 10 Amp AC/DC 0.1%. Complete with batteries & leads. P&P £4 £39.50</p> <p>AS ABOVE. DMM 6010. 0.25% £33.50</p> <p>CARRYING CASE FOR ABOVE £3 each</p> <p>OSCILLOSCOPES PROBES Switched x1; x10. P&P £3 £11</p>
<p>ISOLATING TRANSFORMERS</p> <p>240V In - 240V Out 500VA £15 each P&P £5</p> <p>240V In - 240V Out 100VA £6 each P&P £3</p> <p>240V In - 24V 200VA £5 P&P £4</p> <p>240V In - 24V Out 500VA £6 P&P £5</p> <p>240V In - 24V Out 100VA £4 P&P £4</p>	<p>USED EQUIPMENT - WITH 30 DAYS GUARANTEE. MANUALS SUPPLIED IF POSSIBLE. This is a VERY SMALL SAMPLE OF STOCK. SAE or Telephone for Lists. Please check availability before ordering. CARRIAGE all units £16. VAT to be added to Total of Goods & Carriage.</p> <p>STEWART OF READING</p> <p>110 WYKEHAM ROAD, READING, BERKS RG6 1PL</p> <p>Telephone: 0734 68041 Fax. 0734 351696</p> <p>Callers welcome 9 am-5.30 pm Mon.-Fri. (until 8 pm Thurs.)</p>

MAGENTA ELECTRONICS Ltd

PROJECT KITS

Magenta supply Full Kits: Including PCB's (or Stripboard), Hardware, Components, and Cases (unless stated). Please state Kit Reference Number, Kit Title, and Price, when ordering. REPRINTS: If you do not have the issue of E.E. which includes the project, you will need to order the instruction reprint as an extra: 80p each. Reprints are also available separately—Send £1 in stamps.

REF NO.	KIT-TITLE	PRICE	REF NO.	KIT-TITLE	PRICE
709	AMSTRAO P10 Sept 88	(phone)	542	PERSONAL RADIO June 86	£11.53
708	TIME SWITCH Aug 88	£17.61	543	WATCHDOG June 86	£8.24
707	SPIKEATER July 88	£3.99	529	MINI STROBE May 86	£13.86
706	UNIVERSAL NICAD CHARGER July 88	£6.99	528	PA AMPLIFIER May 86	£26.95
705	ISOLINK July 88	£24.51	523	STEREO REVERB Apr 86	£26.44
704	VIDEO WIPER July 88	£33.59	524	VERSATILE PSU Apr 86	£24.69
703	HEADLIGHT REMINDER June 88	£7.99	526	FRELOADER Apr 86	£8.48
702	DOOR SENTINEL May 88	£12.81	513	BBC MIDI INTERFACE Mar 86	£27.94
701	SUPER SOUND EFFECTS GENERATOR May 88	£12.99	514	INTERVAL TIMER Mar 86	£18.87
700	CABLE & PIPE LOCATOR April 88	£15.35	515	STEREO HI-FI PRE-AMP	£49.19
779	STEREO NOISE GATE April 88	£26.98	512	MAINS TESTER & FUSE FINDER Mar 86	£8.82
778	INDUCTIVE PROXIMITY DET. April 88	£8.63	503	FUNCTION GENERATOR Feb 86	£24.84
777	LOW FUEL ALERT April 88	£6.43	504	POWER SUPPLY FOR ABOVE	£7.62
772	SEMICONDUCTOR TESTER Mar 88	£23.51	497	MUSICAL OODOR BELL Jan 86	£18.72
776	UC DETECTOR Mar 88	£11.80	493	DIGITAL CAPACITANCE METER Dec 85	£41.55
775	ENVELOPE SHAPER Mar 88	£14.99	481	SOLDERING IRON CONTROLLER Oct 85	£5.47
774	SOS ALERT Mar 88	£9.36	473	R.I.A. PRE-AMP Sept 85	£16.74
769	VARIABLE 25V-2A BENCH POWER SUPPLY Feb 88	£49.73	464	STEPPER MOTOR INTERFACE FOR THE BBC COMPUTER less case Aug 85	£11.68
770	CAR LAMP CHECKING SYST Feb 88	£7.10		1035 STEPPER MOTOR EXTRA	£14.50
770	GAME TIMER Feb 88	£14.32		OPTIONAL POWER SUPPLY PARTS	£5.14
765	QUIZMASTER Jan 88	£18.96	461	CONTINUITY TESTER July 85	£6.20
767	TRANSISTOR CURVE TRACER (BBC)	£14.98	459	AMSTRAO USER PORT July 85	£17.67
763	AUDIO SIGNAL GENERATOR Dec 87	£13.64	465	ELECTRONIC DOORBELL June 85	£7.56
764	DUAL MAINS LIGHTS FLASHER Dec 87	£20.98	453	GRAPHIC EQUALISER June 85	£26.94
739	ACCENTED BEAT METRONOME Nov 87	£20.95	444	INSULATION TESTER Apr 85	£19.58
740	ACOUSTIC PROBE Nov 87		432	GAMES TIMER Jan 85	£9.11
	(less bolt & probe)	£16.26	430	SPECTRUM AMPLIFIER Jan 85	£6.91
741	BBC SIDEWAYS RAM/ROM Nov 87	£27.53	417	DOOR CHIME Dec 84	£10.78
744	VIDEO CONTROLLER Oct 87	£29.14	382	BBC MICRO AUDIO STORAGE SCOPE INTERFACE Nov 84	£36.25
745	TRANSTEST Oct 87	£9.70	394	PROXIMITY ALARM Nov 84	£22.66
734	AUTOMATIC PORCH LIGHT Oct 87	£17.17	387	MAINS CABLE DETECTOR Oct 84	£5.53
735	CARAVAN FRIDGE ALERT Oct 87	£5.44	386	DRILL SPEED CONTROLLER Oct 84	£8.68
736	STATIC MONITOR Oct 87	£9.66	381	GUITAR HEAD PHONE AMPLIFIER Sept 84	£7.99
723	ELECTRONIC MULTIMETER Sept 87	£46.96	362	VARICAP AM RADIO May 84	£13.15
729	NOISE GATE Sept 87	£23.25	363	EXPERIMENTAL POWER SUPPLY May 84	£23.58
728	PERSONAL STEREO AMP Sept 87	£14.31	364	SIMPLE LOOP BURGLAR ALARM May 84	£17.16
730	BURST-FRE MAINS CONTROLLER Sept 87	£13.57	358	FUSE/DIODE CHECKER Apr 84	£4.35
724	SUPER SOUND ADAPTOR Aug 87	£38.39	356	QUASI STEREO ADAPTOR Apr 84	£13.73
718	3 BAND 16-30MHz RADIO Aug 87	£26.53	344	SIGNAL TRACER Feb 84	£18.77
719	BUCCANEER I.B. METAL DETECTOR inc. coils and case, less handle and hardware July 87	£26.45	337	BIOLOGICAL AMPLIFIER Jan 84	£24.14
720	DIGITAL COUNTER/FREQ METER (10MHz) inc. case July 87	£67.07	334	CONTINUITY TESTER Dec 83	£12.59
721	MONOMIX July 87	£21.00	332	CHILDREN'S DISCO LIGHTS Dec 83	£10.48
722	FERMOSTAT July 87	£12.14	333	NOVEL EGG TIMER Dec 83 inc. case	£12.90
711	VISUAL GUITAR TUNER Jun 87	£22.99	301	STORAGE SCOPE INTERFACE FOR BBC MICRO Aug 83 less software	£19.34
715	MINI DISCO LIGHT Jun 87	£12.59	299	HIGH POWER INTERFACE BOARD Aug 83 no case	£12.99
709	WINDSCREEN WASHER WARNING May 87	£5.12	292	USER PORT I/O BOARD less cable + plug	£13.22
700	FRIDGE ALARM May 87	£9.88	293	USER PORT CONTROL BOARD July 83 less cable + plug + case	£31.67
707	EQUALIZER (IONISER) May 87	£15.53	277	MW PERSONAL RADIO less case, May 83	£9.60
705	BULB LIFE EXTENDER April 87 (less case)	£5.24	278	MOISTURE DETECTOR May 83	£6.88
703	EXP. SPEECH RECOGNITION April 87	£20.98	270	NOVELTY EGG TIMER April 83 less case	£8.91
700	ACTIVE VIB BURGLAR ALARM Mar 87	£35.65	263	BUZZ OFF March 83	£5.68
581	VIDEO GUARD Feb 87	£39.39	262	PUSH BIKE ALARM Feb 83	£14.77
583	CAR VOLTAGE MONITOR Feb 87	£12.58	255	ZX TAPE CONTROL Nov 82	£8.98
584	SPECTRUM SPEECH SYNTH (no case) Feb 87	£20.52	242	2-WAY INTERCOM July 82 no case	£5.69
578	SPECTRUM I/O PORT less case, Feb 87	£9.44	243	REFLEX TESTER July 82	£9.79
579	STEPPING MOTOR BOOSTER (for above) Feb 87	£5.45	240	EGG TIMER June 82	£8.86
575	HANDS-OFF INTERCOM (per station) inc. case, Jan 87	£10.49	237	CAR LED VOLT/METER less case, May 82	£4.00
569	CAR ALARM Dec 86	£12.47	225	CAMERA OR FLASH GUN TRIGGER Mar 82 less tripod bushes	£17.20
571	RANDOM NUMBER GENERATOR Dec 86	£15.72	205	SUSTAIN UNIT Oct 81	£17.63
568	BBC 16K SIDEWAYS RAM Dec 86	£12.97	206	TAPE NOISE LIMITER Oct 81	£5.976-27
564	CAR FLASHER WARNING Nov 86	£9.37	207	HEADS AND TAILS GAME Oct 81	£3.47
563	2000MHz DIG. FREQUENCY METER Nov 86	£67.98	209	PHOTO FLASH SLAVE Oct 81	£4.79
562	10 WATT AUDIO AMPLIFIER Oct 86	£36.70	211	FUZZ BOX Oct 81	£10.05
561	LIGHT RIDER LAPEL BADGE Oct 86	£10.20	197	0-12V POWER SUPPLY Sept 81	£24.55
560	LIGHT RIDER DISCO VERSION	£19.62	181	SOIL MOISTURE INDICATOR E.E. May 81	£5.66
559	LIGHT RIDER 16 LED VERSION	£13.64	149	GUITAR PRACTICE AMPLIFIER Nov 80	£22.95
558	SCRATCH BLANKER Sept 86	£55.83		SOUND TO LIGHT Nov 80 3 channel	£29.38
556	INFRA-RED BEAM ALARM Sept 86	£28.35	124	SPRING LINE REVERB UNIT Jan 80	£34.27
555	FREEZER FAILURE ALARM Sept 86	£15.50	122	UNIBOARD BURGLAR ALARM Dec 79	£9.38
554	CAR TIMER Sept 86	£8.72	118	OAKROOM TIMER July 79	£4.03
553	BATTERY TESTER Aug 86	£7.19	113	MICROCHIME DOORBELL Feb 79	£21.99
544	TILT ALARM July 86	£7.82	111	SOUND TO LIGHT Sept 78	£10.98
546	CARAVAN BATTERY MONITOR July 86	£17.17	108	IN SITU TRANSISTOR TESTOR Jun 78	£9.42
547	SOUKRIE CONTINUITY TESTER July 86	£3.52	106	WEIRD SOUND EFFECTS GEN Mar 78	£7.82
548	ELECTRONIC SCARECROW July 86	£8.87	101	ELECTRONIC DICE Mar 77	£6.26
540	PERCUSSION SYNTH June 86	£30.43			

TOP KITS

MOSFET VARIABLE BENCH 25V 2.5A POWER SUPPLY



A superb design giving 0-25V and 0-2.5A. Twin panel meters indicate Voltage and Current. Voltage is variable from zero to 25V. Current-Limit control allows Constant Current charging of NICAD batteries, and protects circuits from overload. A Toroidal transformer MOSFET power output device, and Quad op-amp IC design give excellent performance.

OUR KIT REF. 769 £49.73

COMPONENTS, KITS, BOOKS, TOOLS, MOTORS, GEARS, PULLEYS, OPTICAL FIBRES, ROBOTICS, AND MUCH MUCH MORE—IN OUR NEW CATALOGUE £1.00

MOTOR-GEARBOX ASSEMBLIES

Miniature gearboxes complete with quality electric motor. Variable ratios by fitting 1 to 6 gears. 1.5-4.5v, 3-2200 rpm. Long 3mm shaft. Ideal for robots and buggies.

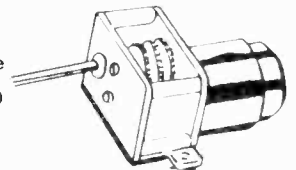

SMALL (MGS) £3.49 LARGE (MGL) £3.98

ADVENTURES WITH ELECTRONICS

An easy to follow book suitable for all ages. No soldering, uses an S DEC breadboard. Lots of clear diagrams and instructions to build 16 projects. Component pack includes S DEC and all components for the projects.

OPTICAL FIBRES TRIAL PACK OF 10 METRES. Nine assorted types & data. £1.99

LEGO Technic Sets TEACHERS WE ARE STOCKISTS OF THE WHOLE RANGE. CONTACT US FOR BROCHURES. VERY COMPETITIVE PRICES AND QUICK DELIVERIES

STEPPING MOTORS 12 VOLT

48 STEPS	200 STEPS
1035	MD200
£14.50	£16.80

MAGENTA ELECTRONICS LTD. SHOP NOW OPEN - CALLERS WELCOME



PE12 135 HUNTER STREET, BURTON-ON-TRENT, STAFFS. DE14 2ST. 0283 65435, Mon-Fri 9-5 Access/Barclaycard (Visa) by phone or post. 24 hr Answerphone for credit card orders. Our prices include VAT

ADD £1 P&P TO ALL ORDERS. PRICES INCLUDE VAT. SAE ALL ENQUIRIES. OFFICIAL ORDERS WELCOME OVERSEAS: Payment must be sterling. IRISH REPUBLIC and BFPO. UK PRICES. EUROPE: UK PRICES plus 10%. ELSEWHERE: write for quote SHOP HOURS: 9-5 MON-FRI.

0283 65435



FROM MAGENTA

A SELECTION OF OUR BEST PROJECT KITS

As usual these kits come complete with printed circuit boards, cases, all components, nuts, screws, wire etc. All have been tested by our engineers (many of them are our own designs) to ensure that you get excellent results.

INSULATION TESTER

An electronic High Voltage tester for mains appliances and wiring. An inverter circuit produces 500 volts from a PP3 battery and applies it to the circuit under test. Reads insulation up to 100 Megohms. Completely safe in use.

OUR KIT REF 444 £19.58



DIGITAL CAPACITANCE METER

Simple and accurate (1%) measurements of capacitors from a few pF up to 1,000 uF. Clear 5 digit LED display indicates exact value. Three ranges pF, nF, and uF. Just connect the capacitor, press the button and read the value.

£41.55
OUR KIT
REF 493

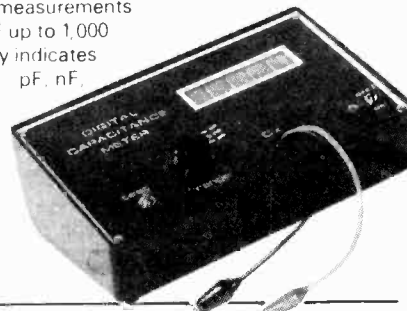

KAYCOMP

LOWCOST

68000

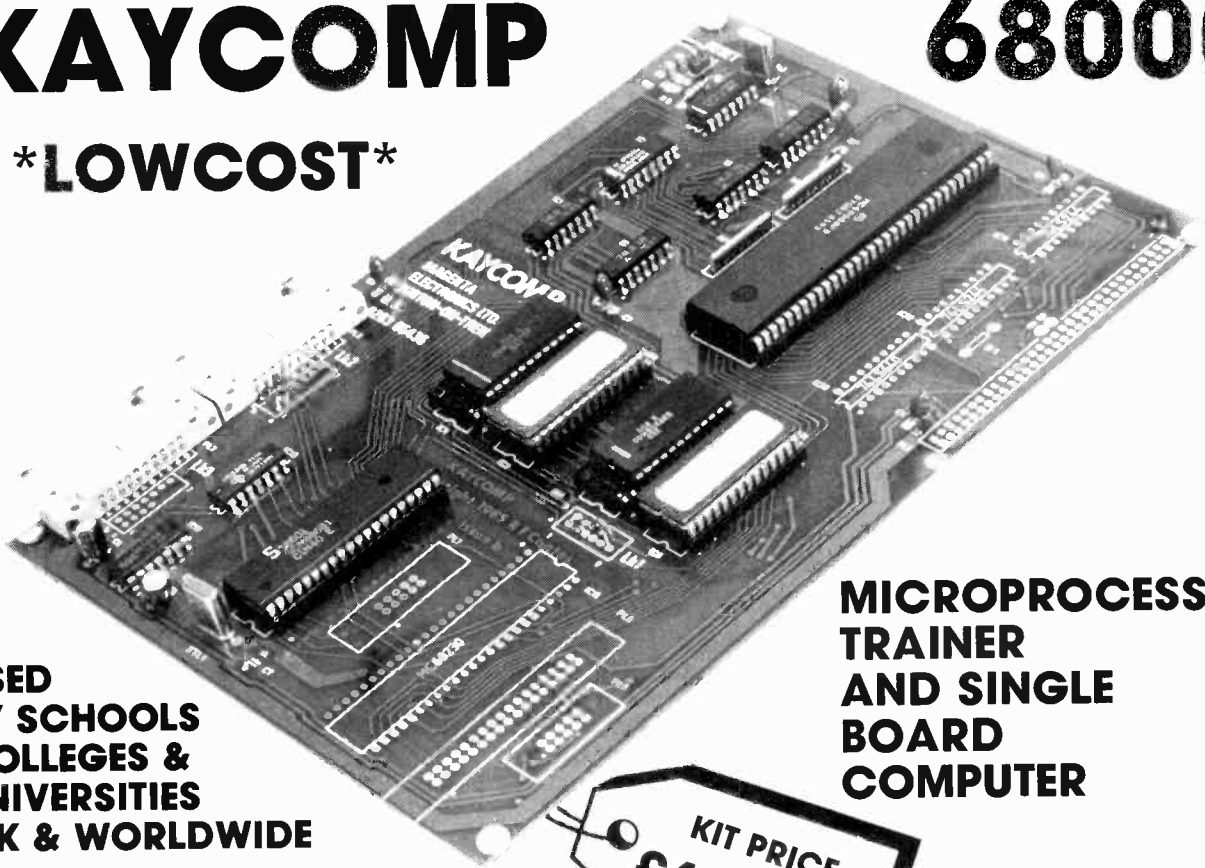

**USED
BY SCHOOLS
COLLEGES &
UNIVERSITIES
U.K & WORLDWIDE**

**MICROPROCESSOR
TRAINER
AND SINGLE
BOARD
COMPUTER**

***PERFECT FOR ROBOTICS
APPLICATIONS REQUIRING
POWER AND SPEED***

**KIT PRICE
£110 INC VAT**

OTHER OPTIONS, DATA PACKS,
AND LITERATURE AVAILABLE
- SEND FOR DETAILS.

- Full 8MHz 68000 Processor with 16 bit data bus.
- Top-class monitor program included on two Eproms.
- Communicates via RS232 Interface to terminal, BBC computer, P.C. computer etc.
- Use as a Trainer, or as a stand-alone computer system.
- Fast, powerful processing - Ideal for real time control systems.
- Dual U.A.R.T. allows simultaneous connection of printer and terminal.
- Add-on options Include: G64 Bus, 68230 P.I.T. 8k and 32K Ram upgrades, and line by line assembler.
- Available from stock now - with support literature and full technical back up.

STANDARD SYSTEM IN KIT FORM	£110.00	68230 P.I.T. ADD ON OPTION	£ 11.97
STANDARD SYSTEM BUILT & TESTED	£190.00	G64 BUS ADD-ON	£ 5.49
LINE BY LINE ASSEMBLER PROGRAM (IN EPROM)	£ 27.00	8K x 16 RAM UPGRADE	£ 19.25
POWER SUPPLY	£ 13.99	32K 16 RAM UPGRADE	£ 28.00

RUBIDIUM VAPOUR CELL RESONATOR

Like the hydrogen maser, the rubidium vapour cell resonator depends on hyperfine energy changes for its operation. However, the levels of interest are the $[F = 1, m_F = 0]$ and $[F = 2, m_F = 0]$ states which can be abbreviated to $F=1$ and $F=2$. The component parts of the rubidium resonator are shown in Fig.8; it employs two isotopes of rubidium, namely Rb85 and Rb87.

Excited atoms in the Rb87 lamp relax down to the $F=2$ and $F=1$ hyperfine levels, emitting light energy as they do

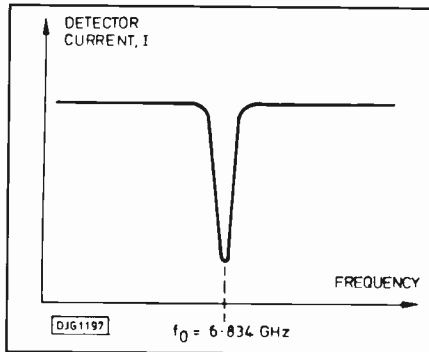

Fig.9. Light detector response

levels, the light energy responsible for this excitation is no longer absorbed and passes through with constant intensity.

frequencies, and a plot of detector current vs frequency (Fig.9) shows a dip at this frequency.

The detector output current is used as a control signal for the vco which acts as a slave oscillator feeding the 6.834GHz microwave energy to the cavity. The actual stability and accuracy of the vco on its own is unimportant, since its output is locked to the $F=2$ to $F=1$ transition frequency by means of the closed loop provided by the light detector.

Consequently, the precision of the vco output is essentially that of the atomic transition frequency; an accuracy of 1 in 10^{11} , and a stability of 1 in 10^{11} per month are typical values.

HI-TECH TIMING

PART 2

BY ANTHONY H. SMITH B.Sc.

Following on from last month's look at quantum physics, masers and lasers, we examine the accuracy of caesium resonators and rubidium standards

so. This light is directed through a filter cell containing Rb85 vapour whose quantum energy levels are very similar to those of Rb87. However, there is just sufficient difference for the Rb85 vapour to act as a selective filter to the Rb87 light.

Consequently, the light energy emitted by transitions down to the $F=2$ level in Rb87 is strongly absorbed by the Rb85 gas, whereas that corresponding to transitions down to the $F=1$ level passes through unaffected.

Therefore, the light leaving the filter cell and entering the Rb87 absorption cell has the correct range of frequencies to pump atoms from the $F=1$ level up into excited states, but *not* atoms in the $F=2$ level (remember, energy is absorbed or emitted according to the formula $E=hf$.) Naturally, this process results in the $F=2$ level having far more atoms than $F=1$, ie, we have a population inversion in the $F=2$ level.

Now, because all the atoms in the $F=1$ state have been pumped up to higher

For most practical purposes, an output frequency much lower than the transition frequency is required, and this can be obtained from a secondary oscillator phase-locked to the vco.

To ensure the rubidium resonator has a high Q-factor, special 'buffer' gases must be added to the filter and absorption cells. However, these gases produce substantial frequency shifts, as does mistuning of the microwave cavity; consequently, the device cannot be used as a primary frequency standard, and must be carefully calibrated at manufacture. Once the cell is adjusted and sealed, however, the frequency remains highly stable and the drift rate is around a hundred times less than the highest quality quartz oscillators.

Another attractive feature of the rubidium oscillator is that, unlike the hydrogen maser and caesium resonator, it re-uses rather than depletes source atoms and so frequent renewal of exhausted parts is unnecessary.

Certain rubidium oscillators do not feature the light detector and vco, but instead take their output directly from the maser energy in the microwave cavity. However, the light source must have higher power, and the cavity tuning and Q-factor become much more critical parameters; thus, systems employing the closed-loop servo mechanism are often preferred, and are known as 'passive' atomic standards.

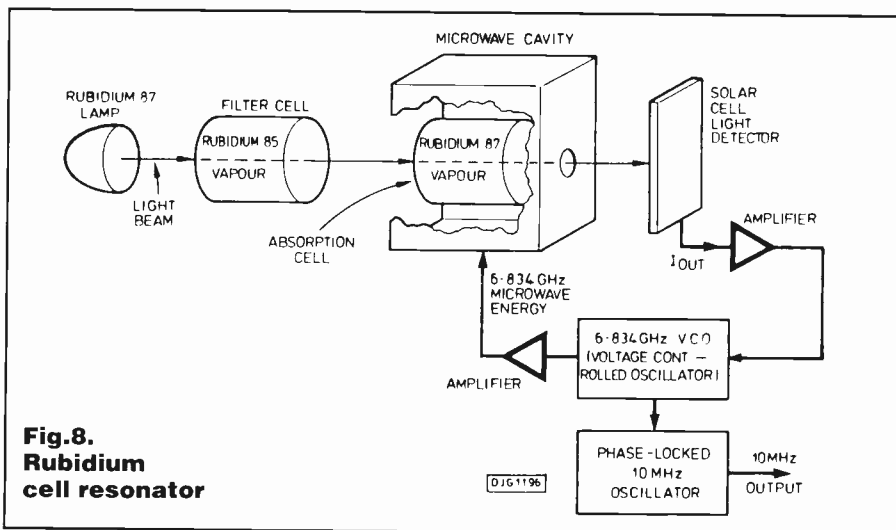

Fig.8. Rubidium cell resonator

THE CAESIUM BEAM RESONATOR

The caesium oscillator shown in Fig.10 is also a passive standard, but in many ways is superior to other atomic references, and advantages such as its excellent long-term stability and relative

insensitivity to magnetic fields make it an ideal choice for the international standard.

oscillator - such that the vco is locked to the atomic transition frequency. It is then a relatively simple matter to synthesise

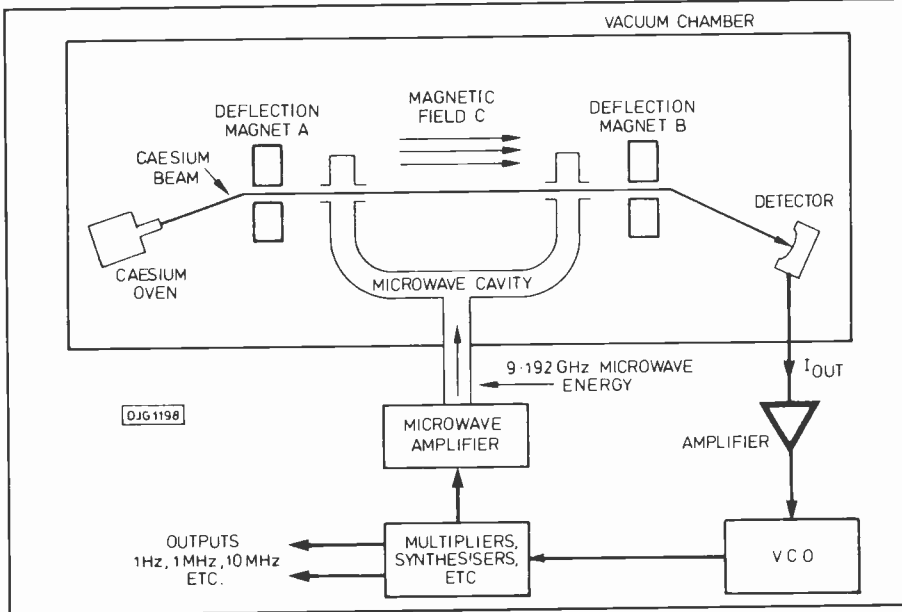

Fig.10. Schematic representation of the caesium beam resonator

Like the hydrogen maser and the rubidium oscillator, the caesium resonator exploits quantum energy transitions to establish the required reference frequency; the transition used occurs between the $[F = 4, m_F = 0]$ and $[F = 3, m_F = 0]$ levels.

Caesium atoms of various energy levels are evaporated from the oven and directed as a beam towards magnet A which deflects each atom through an angle determined by its energy level. Consequently, those atoms in the $F=4$ states are deflected through the microwave cavity towards magnet B, while those in the $F=3$ states are deflected away.

Now, the field gradient of magnet B has the same direction as that of magnet A. Thus, if the atoms arriving at magnet B have *not* made a transition in the cavity, they are still in the $F=4$ state and are deflected *away* from the detector; however, if they *have* made a transition from $F=4$ to $F=3$, they will be deflected so as to strike the detector.

The transitions are stimulated by supplying the cavity with microwave power: if the microwave frequency is close to the transition frequency (9,192,631,770 Hz) many atoms will be induced to make the transition. However, if the frequency is not quite right, the transition probability will decrease; thus the detector output current will peak at the exact transition frequency (Fig.11).

By feeding the detector current to the vco, whose output is multiplied to provide the microwave signal, we have again established a closed-loop servo system - similar to that of the rubidium

other output frequencies, also locked to the atomic transition, and having the same accuracy and stability.

From Fig.11, we see that the resonance curve is about 50Hz wide at half intensity, and so the caesium Q-factor is: $Q = f_0/50 = 9,192,631,770/50 = 183$ million!

The $[F = 4, m_F = 0]$ to $[F = 3, m_F = 0]$ transition is chosen because it is the one least affected by external magnetic fields. Nevertheless, some field dependence does exist, and the exact frequency is given by:

$$f = (f_0 + 427 \times 10^8 \times B^2) = (9,192,631,770 + 427 \times 10^8 \times B^2) \text{ Hz.}$$

Although screening can reduce these effects, it is almost impossible to remove all magnetic influences, and so a small magnetic field - the 'C' field is deliberately induced in the cavity. This

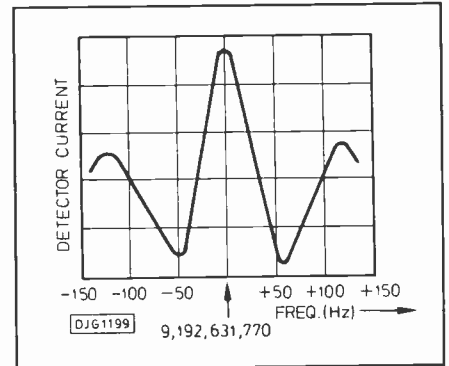

Fig.11. Caesium beam resonance curve

field separates the Zeeman levels, and allows the correct transition to be 'picked out' from those which would otherwise produce unwanted resonant frequencies.

Various other factors can degrade performance. For example, any asymmetry in the microwave cavity will introduce unwanted phase shifts to the microwave field, and the accumulation of caesium deposits on the cavity ends can result in frequency errors as large as 1 part in 10^{11} .

A secure vacuum seal is also important; during development of one of the prototypes at the National Physical Laboratory, Essen and Parry found that the most convenient remedy for small leaks was to bung them with plasticine!

Fig.12 depicts the present caesium resonator at NPL: this formidable mechanism is a third generation machine which boasts an accuracy of 1 part in 10^{11} .

ACCURACY AND AVAILABILITY

When we talk about the accuracy of, say, a tapemeasure, we are concerned with how closely its graduations correspond to those of an accepted standard of length.

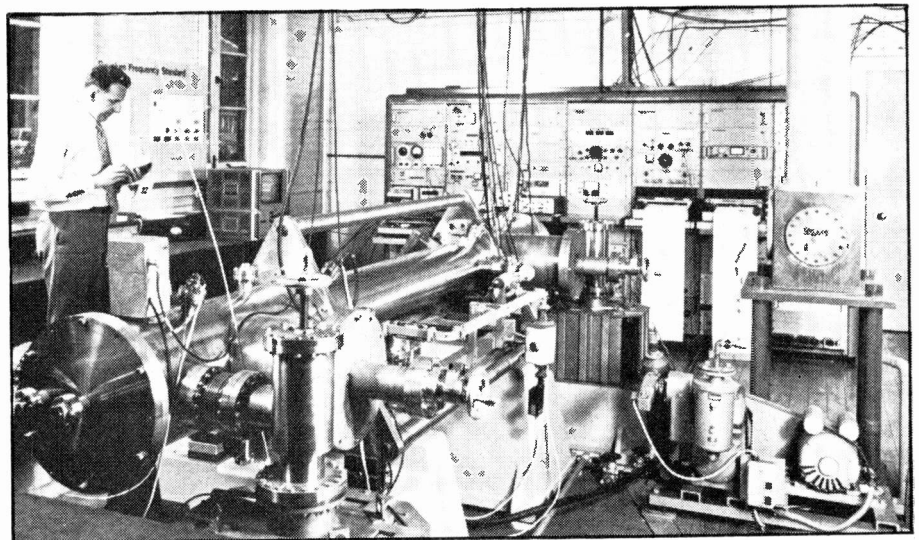

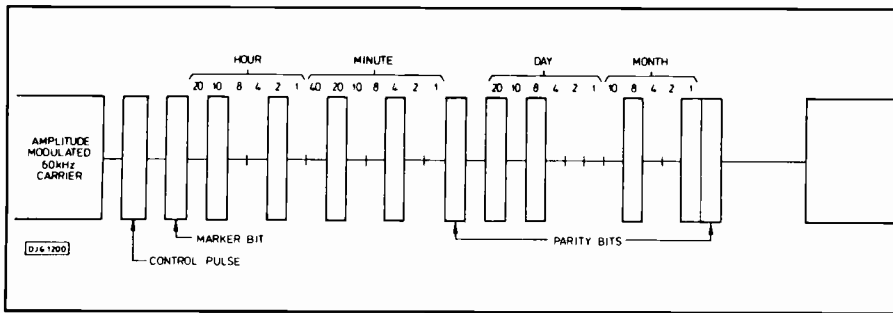

Fig.13. Coded time information on the 60kHz MSF signal

However, when dealing with the caesium standard - which is itself the accepted frequency reference - it is difficult to conceive of its accuracy since we have no superior standard with which to compare it.

Nevertheless, one approach is to measure or estimate the uncertainties of all known parameters which affect the transition frequency, and to combine these figures in a statistical manner to determine theoretically how far the frequency deviates from the value laid down in the definition.

Alternatively, a more practical method regularly conducted by a collection of international laboratories, involves the comparison of scores of caesium resonators in order to determine the average transition frequency: this is then taken as the principal reference value, and each individual resonator can then be 'tweaked' to bring its frequency into line.

Many of these resonators are commercially available, and, indeed, the fundamental purpose in developing any standard is that it can be made available as a reference for accurate measurements.

Hewlett Packard, for example, market the HP5061B caesium beam standard, and the HP5065A rubidium oscillator, both of which can be supplied accurate to a few parts in 10^{12} . However, the price of such accuracy is considerable: the rubidium oscillator costs around £22,500, and the caesium model will set you back a cool £24,000!

Radiocode Clocks of Penryn, Cornwall, supply two rubidium oscillators: one is a compact module measuring just 4 x 4 x 4 inches and accurate to 5 parts in 10^{11} , whereas the RbS 10000 is a microprocessor-controlled instrument for high precision application. Although cheaper than the Hewlett Packard models, these oscillators are still only intended for specialised use, and prices start at around £6000.

Fortunately, for those of us with modest budgets, there is another way to make use of atomic accuracy. For many years now, various authorities throughout the world have broadcast special signals carrying time and frequency information which is locked to an atomic standard.

For example, in Britain, Radio 4 programmes are transmitted from Droitwich, Burghhead and Westerglen on a 198kHz carrier wave which is locked to the BBC's rubidium standards which are periodically checked by the NPL. A similar service is transmitted on 162kHz from Allouis, France.

Another popular British service is the MSF 60kHz signal transmitted from Rugby. MSF began experimentally in 1950 with a one-hour broadcast every day, and was extended in 1966 to provide 24-hour coverage.

The signal comprises a 60kHz carrier synchronised with the NPL caesium resonator, and modulated with a comprehensive code providing year, month, day of month, hour and minute information. For example, in Fig.13, the code represents 12:24 on September 28th.

At the transmitter, the accuracy of a broadcast standard like MSF is essentially equal to that of the controlling standard: thus, MSF has a transmitted accuracy of around ± 2 parts in 10^{12} .

However, the receiver accuracy will be

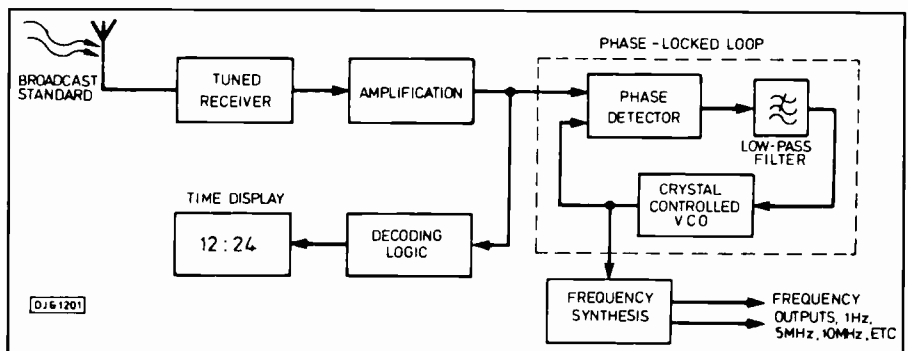

Fig.14. Off-air frequency and time standard

compromised by the effects of noise and propagation errors. High frequency signals propagate in a complex manner as they reflect from the ionosphere back down to earth. Variations in the ionosphere's profile and height introduce a Doppler frequency shift to the signal, and errors as large as several parts in 10^7 can occur.

Low frequency signals, however, follow the earth's curvature, using the ionosphere more as a boundary than a reflector. Consequently, the Doppler

effects are less troublesome to low-frequency transmissions like MSF, although the ionospheric component cannot be ignored, especially during the winter months when it causes maximum disturbance.

A typical arrangement for detecting and decoding the time and frequency information is shown in Fig.14.

The phase-locked-loop is used to lock the high stability crystal vco to the broadcast carrier; thus, the vco output is an exact multiple of the carrier frequency having the same accuracy and stability, and can be used to synthesise other frequencies if desired. In this way, the crystal vco behaves as a 'flywheel' oscillator whose output is constantly corrected by the incoming precision signal; in many cases, the loss of the broadcast signal (for example, due to a break in transmission), need not be catastrophic, since the crystal vco continues to run, albeit with reduced accuracy.

For broadcast signals like MSF which contain time information, suitable decoding logic is also required to generate a 24-hour time display.

Radiocode Clocks market the RFS 1000 which is a portable off-air frequency standard tuned to the 60kHz MSF broadcast, and has decade frequency outputs ranging from 1Hz to 1MHz. The basic model costs around £450 and provides long-term accuracy approaching 1 part in 10^{11} .

The IFS8000, on the other hand, is an 'intelligent' off-air standard which uses a microcomputer-based control system to

improve performance and increase long-term precision to 1 part in 10^{12} .

Such off-air standards can be used as the reference oscillator of a universal counter timer (uct), allowing measurements to be made with accuracies far superior to those obtained with a quartz crystal timebase.

Nevertheless, we shall see in a future article that a variety of operational and systematic errors must be considered before the uct measurement accuracy can approach that of the external standard. **PE**

**OUT
NOW!**

CRICKLEWOOD

ELECTRONICS

1989 100 PAGE COMPONENT CATALOGUE PRICE £1

SEND OFF FOR YOUR COPY TODAY...

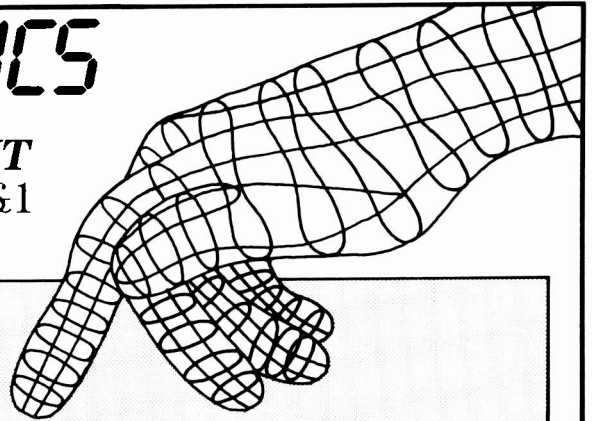

- WE STOCK AN UNRIVALLED RANGE
- ALL OUR COMPONENTS ARE FIRST CLASS BRANDED ITEMS
- WE OFFER A SAME DAY SERVICE ON ALL STOCK ITEMS
- NO MINIMUM ORDER—IF YOU NEED ONE COMPONENT WE CAN SUPPLY ONE COMPONENT
- WE HAVE ADOPTED A NEW LOWER PRICING POLICY + QUANTITY DISCOUNTS
- FREE VOUCHERS WITH YOUR CATALOGUE—ORDER ONE NOW!...

JUST FILL IN THE COUPON OPPOSITE AND POST IT WITH YOUR £1 PAYMENT TO THE ADDRESS BELOW. YOU WILL RECEIVE NOT ONLY OUR SUPERB 100 PAGE CATALOGUE, BUT ALSO FREE VOUCHERS WHICH YOU CAN USE ON YOUR NEXT COMPONENTS ORDER.

CRICKLEWOOD ELECTRONICS LTD 40 CRICKLEWOOD BROADWAY LONDON NW2 3ET TEL: 01-450 0895/452 0161 FAX: 01-208 1441 TELEX: 914977

FREE VOUCHERS!
SEND OFF FOR YOUR CATALOGUE AND VOUCHERS TODAY.

I WOULD LIKE TO RECEIVE.....
COPY(COPIES) OF THE 1989
CRICKLEWOOD ELECTRONICS
COMPONENT CATALOGUE. I
ENCLOSE £.....
PLEASE ENCLOSE MY FREE
VOUCHERS.

Tape your £1 coin here, or send a cheque or postal order for £1.00 for every catalogue you require.

NAME.....

ADDRESS.....



Component Solutions Ltd.

0782 641884

CPU		6551 3.20		2764 2.85		LOGIC		CRYSTALS		APRIL SPECIAL OFFERS	
Z80A	1.20	6845	2.85	27C64	2.75	74LS00	0.14	1.8432MHZ0.90		Z80A CPU	1.20
8085	1.50	6809	1.60	27128	3.50	74LS02	0.14	4 Meg	0.50	2764	2.00
80C85	3.20	6802	1.90	27C128	3.50	74LS04	0.14	6 Meg	0.50	5% DISCOUNT TTL	
8086-2	2.50	6821	1.40	27256	3.50	74LS08	0.14	8 Meg	0.50	★ SUPPLY FROM STOCK	
6502	3.00	6850	1.40	27C256	3.50	74LS10	0.14	10 Meg	0.50	★ FULL PRICE LIST AVAILABLE	
8031	2.20	INTERFACE		27C512	7.00	74LS14	0.15	12 Meg	0.50	★ TRADE ACCOUNTS WELCOMED	
80C31	3.20	1488	0.40	SRAMS		74LS20	0.16	TURN PIN SOCKETS		★ DISCOUNTS ON 74LS AVAILABLE	
63A03	5.00	1489	0.40	6116LP-15	3.00	74LS30	0.16	8W	0.12	COMPONENT SOLUTIONS LTD 112 BURREINGTON DRIVE NEW PARK, TRENTHAM, STAFFORDSHIRE, ST4 8SP. PLEASE ADD 0.75P P&P THEN 15% VAT TO TOTAL ALL TRANSACTIONS CHEQUE WITH ORDER	
8748	5.00	ULN2001 0.60		6264LP-126.00		74LS32	0.16	14W	0.18		
8749	5.00	ULN2002 0.60		62256LP-12	12.50	74LS74	0.16	16W	0.22		
64180-8	12.00	ULN2003 0.60		DRAMS		74LS86	0.16	20W	0.24		
68000-8	8.10	ULN2004 0.60		4164-15	2.40	74LS138	0.18	24W	0.30		
PERIPHERALS		OPTO		41256-15	7.00	74LS139	0.18	28W	0.45		
Z80ACTC	1.20	LEDS		511000-10	26.00	74LS151	0.24	40W	0.55		
Z80API0	1.20	3mm 0.10		REGULATORS		74LS153	0.18	TANT BEADS			
Z80AS10	1.20	5mm 0.15		7805	0.20	74LS164	0.50	.01/35V	0.10		
8155	1.80	ILQ74 1.80		7905	0.20	74LS240	0.18	1/35V	0.10		
8156	1.80	ILQ2 1.50				74LS244	0.24	4.7/16V	0.15		
8243	1.40	MEMORIES EPROMS				74LS245	0.24	10/16V	0.18		
8251	1.20	2716 3.20				74HC/74F + 74HCT					
8253-5	1.20	2732A 3.50				ALSO AVAILABLE					
81C55	1.20										
8212	1.45										
82C55	1.80										
6522	2.40										

ELMASET INSTRUMENT CASE

300 x 133 x 217mm deep £10 ea (£2.20)
REGULATORS
 LM317T PLASTIC TO220 variable £1
 LM317 METAL £2.20
 7812 METAL 12V 1A £1
 7805/12/15/24V plastic 35p 100 + 20p 1000 + 15p
 7905/12/15/24 plastic 35p 100 + 20p 1000 + 15p
 CA3085 T099 variable reg 2/£1
 LM338 5A VARIABLE £5

COMPUTER ICS
 IM6402 UART £3
 8086 processor equipment £2
 USED 41256-15 £4.20
 4164-15 ex equipment £1
 9 x 41256-15 SIMM MODULE NEW £36
 41256-10 SURFACE MOUNT EX NEW BOARDS £2
 HD146818 CLOCK IC £4
 2864 EEPROM £2
 27128A 250nS EPROM NEW £3.20
 1771, 1772 FLOPPY DISC CONTROLLER CHIP £10 ea
 68008 PROCESSOR EX-EQPT £5
 ALL USED EPROMS ERASED AND BLANK CHECKED CAN BE PROGRAMMED IF DESIRED.
 2764-30 USED £2
 2716-45 USED £2 100/£1
 2732-45 USED £2 100/£1
 2764-30 USED £2 100/£1.60
 27128-25/30 USED £2.50
 27C256-30 USED £3
 1702 EPROM EX EQPT £5
 2114 EX EQPT 60p 4116 EX EQPT 70p
 6264-15 8k static ram £6
 4416 RAM £3.50
 USED 4416-15 RAM £2
 ZN427E-8 £3.50
 ZN428E-8 £3.50

CRYSTAL OSCILLATOR

1.8342 MHz 2/£1 each

CRYSTALS

2.77 MHz/4.9152 MHz/49.504MHz £1 each

TRANSISTORS

BC107, BCY70 PREFORMED LEADS full spec £1 £4/100 £30/1000
 BC557, BC548B 30/£1 £3.50/100

SIL RESISTOR NETWORKS

8 PIN 10k 22k 5/£1
 8 PIN 22k 5/£1
 10 PIN 68R 180R 22k 5/£1

POWER TRANSISTORS

OC35 (Marked CV7084) £1
 POWER FET IRF9531 8A 60V 2/£1
 2SC1520 sim BF259 3/£1 100/£22
 TIP141/2 £1 ea TIP112/125/42B 2/£1
 TIP35B TIP35C £1.50
 SE9301 100V 10A DARL. SIM TIP121 2/£1
 2N3055 EX EQPT TESTED 4/£1
 PLASTIC 3055 OR 2955 equiv 50p 100/£35
 2N3773 NPN 25A 160V £1.80 10/£16
 BD132 5/£1

QUARTZ HALOGEN LAMPS

A1/216 24V 150 WATTS £2.25
 H1 12V 50W (CAR SPOT) £1.50

ZIF SOCKETS

TEXTTOOL single in line 32 way. Can be ganged (coupling supplied) for use with any dual in line devices. 2/£1.50

LARGE ELECTROLYTIC CAPACITORS COMPUTER GRADE

300uF 350V SIC SAFCO FELSIC 037 £6 (£1.50)
 2200uF 160V SIC SAFCO FELSIC C038 £4 (£1.20)

TURNS COUNTING DIALS FOR MULTI TURN POTENTIOMETERS

15 turn dial 21mm dia. fits 0.25" spindle £2.50
 10 turn dial 21 mm dia. fits 3mm spindle £2
 10 turn digital dial (3 digits) for 3mm or 6mm shaft £3.50
 10 turn clock face dial for 6mm spindle £4
 6mm bushes can be drilled to fit 0.25" spindles

MISCELLANEOUS

HUMIDITY SWITCH ADJUSTABLE £2
 WIRE ENDED FUSES 0.25A 30/£1
 NEW ULTRASONIC TRANSDUCERS 40kHz £1.50 pair
 12 CORE CABLE 7/0.2mm OVERALL SCREEN. £1/3 metres £1.50
 POWERFUL SMALL CYLINDRICAL MAGNETS 3/£1
 OP AMP LM101CLN £2.90
 BNC 50 OHM SCREENED CHASSIS SOCKET 3/£1
 BNC TO CROC CLIPS LEAD 1 metre £1
 MOULDED INDUCTOR 470uH

size of a 1 watt film resistor 5/£1
 TO-220 HEAT SINK sim RS 403-162 10/£2.50
 SMALL MICROWAVE DIODES AEI DC1028A 2/£1
 D.I.L. SWITCHES 10 WAY £1 8 WAY 80p 4/5/6 WAY 50p
 180 volt 1 watt ZENERS also 12v & 75v 20/£1
 PLASTIC EQUIPMENT CASE 9 x 6 x 1.25 in. WITH FRONT AND REAR PANELS CONTAINING PCB WITH EPROM 2764-30 AND ICS 7417 LS30 LS32 LS74 LS367 LM311 7805 REG. 9 WAY D PLUG, PUSH BUTTON SWITCH, DIN SOCKET £1.90
 VN10LM 60v 1/2A 5ohm TO-92 mosfet 4/£1 100/£20
 MIN GLASS NEONS 10/£1
 RELAY 5v 2 pole changeover looks like RS 355-741 marked STC 47WB05T £1 ea
 MINIATURE CO-AX FREE PLUG RS 456-071 2/£1
 MINIATURE CO-AX FREE SKT. RS 456-273 2/£1.50
 DIL REED RELAY 2 POLE n/o CONTACTS £1
 PCB WITH 2N2646 UNIJUNCTION with 12v 4 POLE RELAY £1
 400m 0.5w thick film resistors (yes four hundred megohms) 4/£1
 MINIATURE CO-AX FREE PLUG RS 456-071 2/£1
 MINIATURE CO-AX FREE SKT. RS 456-273 2/£1.50
 STRAIN GAUGES 40 ohm Foil type polyester backed balco grid alloy £1.50 ea 10 + £1
 ELECTRET MICROPHONE INSERT £0.90
 Linear Hall effect IC Micro Switch no 613 SS4 sim RS 304-267 £2.50 100 + £1.50

HALL EFFECT IC UGS3040 + MAGNET £1
 OSCILLOSCOPE PROBE SWITCHED X1 X10 £10
 CHEAP PHONO PLUGS 100/£2 1000/£18
 1 pole 12 way rotary switch 4/£1
 AUDIO ICS LM380 LM386 £1 ea
 555 TIMER 5/£1 741 OP AMP 5/£1
 ZN414 AM RADIO CHIP 80p
 COAX PLUGS nice ones 4/£1
 COAX BACK TO BACK JOINERS 3/£1
 4 x 4 MEMBRANE KEYBOARD £1.50
 15.000uF 40V £2.50 (£1.25)
 INDUCTOR 20uH 1.5A 5/£1
 NEW BT PLUG + LEAD £1.50
 1.25" PANEL FUSEHOLDERS 3/£1
 CHROMED STEEL HINGES 14.5 x 1" OPEN £1 each
 12v 1 2w small wire ended lamps fit AUDI VW TR7 SAAB VOLVO 10/£1
 12V MES LAMPS 10/£1
 STEREO CASSETTE HEAD 10/£1
 MONO CASS HEAD £1 ERASE HEAD 50p
 THERMAL CUT OUTS 50 77 85 120°C £1 ea
 THERMAL FUSE 121°C 240V 15A 5/£1
 TRANSISTOR MOUNTING PADS TO-5/TO-18 £3/1000
 TO-3 TRANSISTOR COVERS 10/£1
 STICK ON CABINET FEET 30/£1
 PCB PINS FIT 0.1" VERO 200/£1
 TO-220 micas + bushes 10 50p 100/£2
 TO-3 micas + bushes 15/£1
 PTFE min screened cable 10m/£1
 Large heat shrink sleeving pack £2
 CERAMIC FILTERS 6M/9M/10.7M 50p 100/£20
 MAINS LEAD WITH MOULDED 13A PLUG AND IEC SOCKET £1.50
 IEC chassis plug rfi filter 10A £3
 Potentiometers short spindles values 2k5 10k 25k 1m £1
 2M5 lin 5/£1
 500K lin 500k log 4/£1
 40KHz ULTRASONIC TRANSDUCERS EX-EQPT NO DATA £1/pr
 PLESSEY INVERTER TRANSFORMER 50 CYCLES
 11 5.0-11.5V to 240v 200VA £6 (£3)

ZENERS
 5.6V 1W3 SEMIKRON 50K AVAILABLE @ £25/1000
 SUPPRESSOR OF606 120V BI DIRECTIONAL ZENER IN 3 AMP W/E PACKAGE 5/£1

DIODES AND RECTIFIERS

1N4148 100/£1.50
 1N4004/SD4 1A 300V 100/£3
 1N5401 3A 100V 10/£1
 BA158 1A 400V fast recovery 100/£3
 BA159 1A 1000V fast recovery 100/£4
 120V 35A STUD 65p
 BY127 1200V 1.2A 10/£1
 BY254 800V 3A 8/£1
 BY255 1300V 3A 6/£1
 6A 100V SIMILAR MR751 4/£1
 1A 800V BRIDGE RECTIFIER 4/£1
 4A 100V BRIDGE 3/£1
 6A 100V BRIDGE 2/£1
 8A 200V BRIDGE £1.35
 10A 200V BRIDGE £1.50
 25A 200V BRIDGE £2 10/£18
 25A 400V BRIDGE £2.50 10/£22

SCRS

PULSE TRANSFORMERS 1:1 + 1 100/£1.25
 2P4M EQUIV C106D 3/£1
 MCR72-6 10A 600V SCR £2
 35A 600V STUD SCR £1
 TICV106D 800mA 400V SCR 3/£1 100/£15

MEU21 PROG UNIJUNCTION 3/£1

TRIACS

BT137-600 8A TO-220 2/£1
 BT138-600 12A TO-220 70p
 NEC TRIAC AC08F 8A 600V TO220 5/£2 100/£30
 TXAL225 8A 400V 5mA GATE 2/£1 100/£35
 TRAL2230D 30A 400V ISOLATED STUD £4 each

CONNECTORS

D25 IDC SOCKET FUJITSU £2
 34 way card edge IDC CONNECTOR (disk drive type) £1.25
 CENTRONICS 36 WAY IDC PLUG £2.50
 CENTRONICS 36 WAY IDC SKT £4.00
 BBC TO CENTRONICS PRINTER LEAD 1.5M £3.50
 CENTRONICS 36 WAY PLUG SOLDER TYPE £4
 USED CENTRONICS 36W PLUG + SKT £3

USED D CONNECTORS price per pair

D9 60p, D15 £1.50, D25 £2, D37 £2, D50 £3.50 covers 50p ea.

WIRE WOUND RESISTORS

W21 or sim 2.5W 10 of one value £1
 R10 OR15 OR22 2R0 2R7 4R7 5R0 5R6 8R2 10R 12R 15R 18R 20R 22R 27R 33R 47R 56R 62R 91R 120R 180R 390R 430R 470R 680R 820R 910R 1K15 1K2 1K5 1K8 2K4 2K7 3K3 3K0 5K0 R05 (50 milli-ohm) 1% 3w 4 FOR £1
 W22 or sim 6W 7 OF ONE VALUE £1
 R47 R62 1R0 1R5 1R8 3R3 6R8 9R1 12R 20R 24R 27R 33R 51R 56R 62R 68R 100R 120R 180R 220R 390R 560R 620R 910R 1K0 1K2 1K5 1K8 2K2 2K7 3K3 3K9 4K7 8K2 10k 15K 16K 20K £1
 W23 or sim 9W 6 of one value £1
 R22 R47 1R0 1R1 15R 56R 62R 100R 120R 180R 220R 300R 390R 680R 1K0 1K5 5K1 10K £1
 W24 or sim 12W 4 OF ONE VALUE £1
 R50 2R0 9R1 18R 22R 27R 56R 68R 75R 82R 100R 150R 180R 200R 220R 270R 400R 620R 1K0 6K8 8K2 10K 15K

PHOTO DEVICES

SLOTTED OPTO-SWITCH OPCOA OPB815 £1.30
 2N5777 50p
 TIL81 PHOTO TRANSISTOR £1
 TIL38 INFRA RED LED 5/£1
 4N25, OP12252 OPTO ISOLATOR 50p
 PHOTO DIODE 50p 6/£2
 MEL12 (PHOTO) ORPINGTON BASE n/c 50p
 RPY58A LDR 50P DRL12 LDR 70p
 LEDs RED 3 or 5mm 12/£1 100/£6
 LEDs GREEN OR YELLOW 10/£1 100/£6.50
 LEDS ASSORTED RD/GN/YW + INFRA/RED 200/£5
 FLASHING RED OR GREEN LED 5mm 50p 100/£35

STC NTC BEAD THERMISTORS

G22 220R, G13 1K, G23 2K, G24 20K, G54 50K, G25 200K, G16 1M, RES @ 20°C DIRECTLY HEATED TYPE £1 ea
 FS222B NTC BEAD INSIDE END OF 1" GLASS PROBE 15/£1
 RES @ 20°C 200R £1 ea

CERMET MULTI TURN PRESETS 3/4"

10R 20R 100R 200R 250R 500R 2K 2K2 2K5 5K 10K 47K 50K 100K 200K 500K 2M2 50p each

IC SOCKETS

6 pin 15/£1 8 pin 12/£1 14/16 pin 10/£1 18/20 pin 7/£1, 22/24/28 pin 4/£1 40 pin 30p

SOLID STATE RELAYS

40A 250V AC SOLID STATE RELAYS £18

POLYESTER/POLYCARB CAPS

100n 63v 5mm 20/£1 100/£3 1000/£25
 1n/3n/5n/6n/8n/2/10n 1% 63v 10mm 100/£6
 10n/15n/22n/33n/47n/68n 10mm rad 100/£3.50
 100n 250v radial 10mm 100/£3
 100n 600v sprague axial 10/£1 100/£6 (£1)
 2u2 160v rad 22mm 100/£10
 10n/33n/47n 250v ac x rated 15mm 10/£1
 470n 250v ac x rated rad 4/£1
 1U 600V MIXED DIELECTRIC 50p ea.

RF BITS

12 volt CO-AXIAL relays sim. RS 349-686 £6
 Ex-equipment, with BNC tails £50p
 10/£1 TRIMMER CAPS ALL 4/50p
 8/£1 SMALL 5p 2 pin mounting 5mm centres 4/50p
 6/£1 SMALL MULLARD 2 to 22pF 4/50p
 4/£1 SMALL MULLARD 5 to 50pF 4/50p
 4/£1 grey larger type 2 to 25pF 60p
 3/£1 TRANSISTORS 2N4427 10/£1
 2/£1 FEED THRU CERAMIC CAPS 1000pF

MINIATURE RELAYS Suitable for RF

5 volt coil 1 pole changeover £1
 10/£18 5 volt coil 2 pole changeover £1
 12 volt coil 1 pole changeover £1

MONOLITHIC CERAMIC CAPICITORS

£1 10n 50v 2.5mm 100/£4.50
 £2 100n 50v 2.5mm or 5mm 100/£6
 £1 100n ax short leads 100/£3

KEYTRONICS

TEL. 0279-505543
 FAX. 0279-757656
 P O BOX 634
 BISHOPS STORTFORD
 HERTFORDSHIRE CM23 2RX

MAIL ORDER ONLY
 MIN CASH ORDER £3.00 OFFICIAL ORDERS WELCOME
 UNIVERSITIES COLLEGES SCHOOLS GOVT DEPARTMENTS
 MIN. ACCOUNT ORDER £10.00
 P&P AS SHOWN IN BRACKETS (HEAVY ITEMS)
 65p OTHERWISE (LIGHT ITEMS)

**ADD 15% VAT TO TOTAL
 ELECTRONIC COMPONENTS
 BOUGHT FOR CASH**



READERS' SURVEY!

HELP US PLAN THE FUTURE!

£100, £50 AND £25 TO BE WON
PLUS REDUCED PRICE
SUBSCRIPTIONS OFFER

WE'RE NEARLY 25 YEARS OLD AND ARE
PLANNING FOR THE NEXT 25!
WE ASK FOR YOUR HELP.

The future Editorial policy of PE is in your hands - it will be determined by your replies to this questionnaire. The opinions of every single one of you are of great importance to us. Whether you read PE regularly, or this issue is the first one you've seen, we want to hear from you. Not only will you play a vital part, but each of you who replies will be sent A VOUCHER WORTH £2 off your next subscription.

Not only that, there are THREE CASH PRIZES to be won. The person who most closely estimates the number of questionnaires received back will be sent £100. The next nearest will be sent £50 and the third nearest will be sent £25. £5 each will go to the next five. The questionnaires must be received back by 31st May 1989.

PE TAKES YOU FURTHER ON THE HI-TECH ROAD - WITH YOUR HELP WE'LL TAKE YOU FURTHER STILL. BE PART OF US!

YOUR ANSWERS TO THE QUESTIONS WILL REMAIN TOTALLY CONFIDENTIAL

YOU MAY SEND A PHOTOCOPY OF THIS FORM

PLEASE TICK THE APPROPRIATE BOX!

1. How long have you been interested in electronics?

- Less than a year
Between 1 and 5 years
Between 6 and 10 years
More than 10 years

2. What is your present involvement in electronics?

(you may tick more than one box)

- As a hobby
As a profession/trade
Research and development
Servicing and installation
As a student
As a teacher

3. Below is a list of topics which have been covered in various issues of PE. We should like to know how interested you are in reading constructional articles on each subject.

	Very	Quite	Not very	Not at all
Astronomy projects	<input type="checkbox"/>	<input type="checkbox"/>	<input type="checkbox"/>	<input type="checkbox"/>
Audio/hif	<input type="checkbox"/>	<input type="checkbox"/>	<input type="checkbox"/>	<input type="checkbox"/>
Boating/sailing electronics	<input type="checkbox"/>	<input type="checkbox"/>	<input type="checkbox"/>	<input type="checkbox"/>
Car electronics	<input type="checkbox"/>	<input type="checkbox"/>	<input type="checkbox"/>	<input type="checkbox"/>
Computers	<input type="checkbox"/>	<input type="checkbox"/>	<input type="checkbox"/>	<input type="checkbox"/>
Computer add-ons	<input type="checkbox"/>	<input type="checkbox"/>	<input type="checkbox"/>	<input type="checkbox"/>
Environmental projects	<input type="checkbox"/>	<input type="checkbox"/>	<input type="checkbox"/>	<input type="checkbox"/>
Household projects	<input type="checkbox"/>	<input type="checkbox"/>	<input type="checkbox"/>	<input type="checkbox"/>
Ingenuity Unlimited	<input type="checkbox"/>	<input type="checkbox"/>	<input type="checkbox"/>	<input type="checkbox"/>
Logic	<input type="checkbox"/>	<input type="checkbox"/>	<input type="checkbox"/>	<input type="checkbox"/>
Metal detectors	<input type="checkbox"/>	<input type="checkbox"/>	<input type="checkbox"/>	<input type="checkbox"/>
Microprocessors	<input type="checkbox"/>	<input type="checkbox"/>	<input type="checkbox"/>	<input type="checkbox"/>
Musical projects	<input type="checkbox"/>	<input type="checkbox"/>	<input type="checkbox"/>	<input type="checkbox"/>
Photographic accessories	<input type="checkbox"/>	<input type="checkbox"/>	<input type="checkbox"/>	<input type="checkbox"/>
Radio	<input type="checkbox"/>	<input type="checkbox"/>	<input type="checkbox"/>	<input type="checkbox"/>
Radio control (of models)	<input type="checkbox"/>	<input type="checkbox"/>	<input type="checkbox"/>	<input type="checkbox"/>
Robots	<input type="checkbox"/>	<input type="checkbox"/>	<input type="checkbox"/>	<input type="checkbox"/>
Security systems	<input type="checkbox"/>	<input type="checkbox"/>	<input type="checkbox"/>	<input type="checkbox"/>
Sound effects	<input type="checkbox"/>	<input type="checkbox"/>	<input type="checkbox"/>	<input type="checkbox"/>
Test equipment	<input type="checkbox"/>	<input type="checkbox"/>	<input type="checkbox"/>	<input type="checkbox"/>
Toys and games	<input type="checkbox"/>	<input type="checkbox"/>	<input type="checkbox"/>	<input type="checkbox"/>
Train-set control	<input type="checkbox"/>	<input type="checkbox"/>	<input type="checkbox"/>	<input type="checkbox"/>
TV/video	<input type="checkbox"/>	<input type="checkbox"/>	<input type="checkbox"/>	<input type="checkbox"/>

4. We'd also like to know how interested you are in each of the following articles in PE:

	Very	Quite	Not very	Not at all
Advertisements	<input type="checkbox"/>	<input type="checkbox"/>	<input type="checkbox"/>	<input type="checkbox"/>
Commercial equipment	<input type="checkbox"/>	<input type="checkbox"/>	<input type="checkbox"/>	<input type="checkbox"/>
Consumer equipment	<input type="checkbox"/>	<input type="checkbox"/>	<input type="checkbox"/>	<input type="checkbox"/>
Environment technology	<input type="checkbox"/>	<input type="checkbox"/>	<input type="checkbox"/>	<input type="checkbox"/>
Future developments	<input type="checkbox"/>	<input type="checkbox"/>	<input type="checkbox"/>	<input type="checkbox"/>
Historical information	<input type="checkbox"/>	<input type="checkbox"/>	<input type="checkbox"/>	<input type="checkbox"/>
Home automation	<input type="checkbox"/>	<input type="checkbox"/>	<input type="checkbox"/>	<input type="checkbox"/>
Medical electronics	<input type="checkbox"/>	<input type="checkbox"/>	<input type="checkbox"/>	<input type="checkbox"/>
Military electronics	<input type="checkbox"/>	<input type="checkbox"/>	<input type="checkbox"/>	<input type="checkbox"/>
New products	<input type="checkbox"/>	<input type="checkbox"/>	<input type="checkbox"/>	<input type="checkbox"/>
News from industry	<input type="checkbox"/>	<input type="checkbox"/>	<input type="checkbox"/>	<input type="checkbox"/>
Readers' letters	<input type="checkbox"/>	<input type="checkbox"/>	<input type="checkbox"/>	<input type="checkbox"/>
Space and astronomy	<input type="checkbox"/>	<input type="checkbox"/>	<input type="checkbox"/>	<input type="checkbox"/>
Sports (electronics in)	<input type="checkbox"/>	<input type="checkbox"/>	<input type="checkbox"/>	<input type="checkbox"/>
Theory of electronics	<input type="checkbox"/>	<input type="checkbox"/>	<input type="checkbox"/>	<input type="checkbox"/>
Transport technology	<input type="checkbox"/>	<input type="checkbox"/>	<input type="checkbox"/>	<input type="checkbox"/>

5. How would you describe your expertise in electronics?

- Beginner
Average
Advanced
Very advanced

6. On the whole, do you find that the constructional projects in PE are:

- Much too simple
A little too simple
Just about right
A little too difficult
Much too difficult

7. How would you rate the information given to you for constructing projects?

- Excellent Good Adequate Poor

8. On the whole, how expensive do you find the constructional projects in PE?

- Much too expensive to complete
A little too expensive to complete
Not too expensive to complete

please turn over

9. When you build a constructional project published in PE, do you:

- Always complete it
- Nearly always complete it
- Sometime complete it
- Never complete it

10. Are the constructional projects published in PE interesting because you want to:

- | | Always | Usually | Sometimes | Never |
|---|--------------------------|--------------------------|--------------------------|--------------------------|
| Build the exact project shown | <input type="checkbox"/> | <input type="checkbox"/> | <input type="checkbox"/> | <input type="checkbox"/> |
| Modify the project to suit your own needs | <input type="checkbox"/> | <input type="checkbox"/> | <input type="checkbox"/> | <input type="checkbox"/> |
| Use parts of the circuit for other purposes | <input type="checkbox"/> | <input type="checkbox"/> | <input type="checkbox"/> | <input type="checkbox"/> |
| Just read how the circuit works | <input type="checkbox"/> | <input type="checkbox"/> | <input type="checkbox"/> | <input type="checkbox"/> |

11. Which other topics, projects or articles, if any, would you like to see covered in PE?

12. How many electronics projects (from any source) have you constructed in the last year?

- | | | | | |
|--------------------------|--------------------------|--------------------------|--------------------------|--------------------------|
| None | 1-2 | 3-5 | 6-10 | over 10 |
| <input type="checkbox"/> | <input type="checkbox"/> | <input type="checkbox"/> | <input type="checkbox"/> | <input type="checkbox"/> |

13. Please list the projects (from any source) you have constructed in the last year (even if you didn't complete them).

14. How much money do you estimate that you have spent in the last 12 months on components, kits, materials, etc.

15. Do you have difficulty obtaining the components for the projects you construct?

- | | | | |
|--------------------------|--------------------------|--------------------------|--------------------------|
| Very | Quite | Rarely | Never |
| <input type="checkbox"/> | <input type="checkbox"/> | <input type="checkbox"/> | <input type="checkbox"/> |

16. When obtaining components for the projects you build, do you prefer to:

- Shop around for the best prices
- Buy from a regular supplier you have come to know
- Buy as a kit from a single source

17. How often do you use each of the following sources for obtaining the components you need?

- | | Very | Quite | Rarely | Never |
|------------------------------------|--------------------------|--------------------------|--------------------------|--------------------------|
| Mail order through catalogues | <input type="checkbox"/> | <input type="checkbox"/> | <input type="checkbox"/> | <input type="checkbox"/> |
| Mail order through magazines | <input type="checkbox"/> | <input type="checkbox"/> | <input type="checkbox"/> | <input type="checkbox"/> |
| Personally through a retail outlet | <input type="checkbox"/> | <input type="checkbox"/> | <input type="checkbox"/> | <input type="checkbox"/> |
| Some other source (state which) | <input type="checkbox"/> | <input type="checkbox"/> | <input type="checkbox"/> | <input type="checkbox"/> |

18. Do you make your own printed circuit boards?

- | | | |
|--------------------------|--------------------------|--------------------------|
| Always | Sometimes | Never |
| <input type="checkbox"/> | <input type="checkbox"/> | <input type="checkbox"/> |

19. How long have you been reading PE?

- | | | | | |
|--------------------------|--------------------------|--------------------------|--------------------------|--------------------------|
| under 1 year, | 1-2 years, | 3-5 years, | 6-10 years, | over 10 years. |
| <input type="checkbox"/> | <input type="checkbox"/> | <input type="checkbox"/> | <input type="checkbox"/> | <input type="checkbox"/> |

20. How often, if at all, do you read each of the following magazines?

- | | Most/all copies | Sometimes | Never |
|---------------------------------|--------------------------|--------------------------|--------------------------|
| Practical Electronics | <input type="checkbox"/> | <input type="checkbox"/> | <input type="checkbox"/> |
| Electronics (Maplin) | <input type="checkbox"/> | <input type="checkbox"/> | <input type="checkbox"/> |
| Electronics and Wireless World | <input type="checkbox"/> | <input type="checkbox"/> | <input type="checkbox"/> |
| Electronics Today International | <input type="checkbox"/> | <input type="checkbox"/> | <input type="checkbox"/> |
| Elektron | <input type="checkbox"/> | <input type="checkbox"/> | <input type="checkbox"/> |
| Everyday Electronics | <input type="checkbox"/> | <input type="checkbox"/> | <input type="checkbox"/> |
| Practical Wireless | <input type="checkbox"/> | <input type="checkbox"/> | <input type="checkbox"/> |
| Television | <input type="checkbox"/> | <input type="checkbox"/> | <input type="checkbox"/> |
| Other magazines (say which) | <input type="checkbox"/> | <input type="checkbox"/> | <input type="checkbox"/> |

21. How do you usually see the copies of PE that you read?

- Buy my own copies
- Read someone else's copy
- Read copies taken by my school
- Read copies taken by my firm/organisation

22. What do you usually do with the copies of PE that you see?

- Throw them away after I have read them
- Keep them for future reference
- Pass them on to someone else

23. Which daily newspaper, if any, do you read?

24. Please tick which age group you are in:

- | | | | | | | |
|--------------------------|--------------------------|--------------------------|--------------------------|--------------------------|--------------------------|--------------------------|
| Under 16, | 16-24, | 25-34, | 35-44, | 45-54, | 55-64, | 65+ |
| <input type="checkbox"/> | <input type="checkbox"/> | <input type="checkbox"/> | <input type="checkbox"/> | <input type="checkbox"/> | <input type="checkbox"/> | <input type="checkbox"/> |

25. Please say whether you are:

- | | | | | |
|--------------------------|--------------------------|--------------------------|--------------------------|--------------------------|
| Studying | employed | Self-employed | Between jobs | Retired |
| <input type="checkbox"/> | <input type="checkbox"/> | <input type="checkbox"/> | <input type="checkbox"/> | <input type="checkbox"/> |

26. If you are a student or teacher, how important is electronics on the school/college timetable:

- | | | | |
|--------------------------|--------------------------|--------------------------|--------------------------|
| Very | Quite a lot | Not very | Not at all |
| <input type="checkbox"/> | <input type="checkbox"/> | <input type="checkbox"/> | <input type="checkbox"/> |

27. Please say in which hobbies or other leisure activities you are most active or interested:

NAME AND ADDRESS (IN BLOCK LETTERS):

.....

.....

.....

.....

MY ESTIMATE OF THE TOTAL NUMBER OF QUESTIONNAIRES RETURNED TO PE IS :

ALL YOUR ANSWERS WILL REMAIN TOTALLY CONFIDENTIAL!

SEND THIS FORM (OR A PHOTOCOPY) TO:
Practical Electronics, Survey Dept,
193 Uxbridge Road,
London W12 9RA

Write to us if you have further opinions to express!

NEW THIS MONTH

32 page **SPRING SUPPLEMENT** featuring Calculators, Disco Gear, Speaker Cabs, Metex Meters, + lots of surplus! **FREE** with Cat, or send large SAE

WIN a top of the range Metex Meter! Enter our Competition - full details in the Spring Supplement!

FREE Headphones + Speakers - Full details in the Spring Supplement.

VIDEOTAPES - Top quality VHS E180 tapes by Videolab at unbelievable prices! £2.50ea. 10/£20. 40/£64.

13A TEST PLUG - 2 neons illuminate to show any faults on line Only 99p

HALOGEN SPOTLIGHT

ML328 Incredible 50,000 candle power given out by this high power spotlight. Operates from 12V DC - plugs into car cigarette lighter socket. Rated 55 watts. Coiled cord extends to 3.6m. On/off switch and plastic hanger are two further features. Robustly made in high impact black plastic with glass lens. £6.95

SOLDER BARGAIN

Shipping error to our supplier means you benefit! 500gm reel of 16SWG resin cored solder at a low, low price. **ONLY £3.95; 10 reels £33.00; 50 reels £150.00**

POWER SUPPLY

Z4170 Plug in power supply. Built in 13A plug. Output 6V DC 300mA on 2m long lead terminated in a 3mm power plug British Made to BS415 £1.50

JUST ARRIVED

60,000 Miniature toggle & other switches. Ring or write for full listing. Prices from 5p!

EPSON SERIAL INTERFACES

Model 8143 £15
Model 8143 with 2k buffer £25
Just arrived - full details on next list

HALF PRICE KITS!!

Range of 'OK' Kits at half price! 5 diff. top quality kits containing all parts, inc. PCB, plastic case and comprehensive instructions!

EK1 Quick Reaction £2.90
EK2 Electronic Organ £3.34
EK3 Digital Roulette £4.29
EK4 Electronic Dice £3.98
EK5 Morse Code Oscillator £1.99

CURRAH MICROSPEECH

We've bought up remaining stocks of this popular add-on to re-sell at a fraction of the original cost!

Z4136 New complete and boxed set for the ZX Spectrum £8.95

Z4140 As above but unboxed - these were bulk packed £7.95

Z4142 Speech 64 for the C64. No software needed! New and working, but no case. With full instructions £6.00

Z4138 Microslot 'T' connector allowing peripherals to be connected to the Spectrum. New & boxed £2.00

Also a quantity of 'returns' available - see Bargain List 43 for details

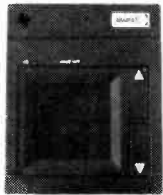

Z811 Cumana touch pad for the BBC B computer. Enables you to draw on the screen using the stylus with the touch sensitive pad. Supplied with 2 stylus, power/connecting leads and demo tape with 4 progs. Originally sold at £79.95
Our price: £19.95

SOLDER SPECIAL!!

* 15W 240V ac soldering iron
* High power desolder pump
* Large tube solder

ALL FOR
£7.95

1989 CATALOGUE

★ 100 BIG pages of components and equipment

★ Low, low prices

★ Fast "by return" service

★ 28 pages of Surplus Bargains

★ Only £1 - send for yours now!

LCD display:

Z4115 8 digit 12.7mm high LCD by Data Image. 14 segment, so letters as well as digits can be formed. List £15+
Our price **£4.50**

Z4148 6 Digit LCD, 50 pins DIL 12.7mm digit height, with ?????? £3.00

SPEECH SYNTHESIZER KIT

Z315 All parts inc. PCB to make a speech synth for the BBC micro **£4.99**

Z316 De-luxe version - also includes V215 case, 1m 20W cable plus connector **£7.99**

MICRO PANELS

Z620 68000 Panel. PCB 190 x 45 believed to be from ICL's 'One per Desk' computer containing MC68008P8 (8MHz) 16.8 bit microprocessor, + 4 ROM's all in skts; TMP5220CNL -74HC7245, 138, LS08, 38 etc. **£5.00**

Z625 32k Memory Board, PCB 170 x 170 with 16 2k x 8 6116 static RAM's. Also 3x 100mA mempack nicad. 13 other HC/LS devices, 96w edge plug, 8 way DIL switch R's, C's etc. **£4.80**

JIMMY

the electronic football game of skill

Z817 Exciting electronic football game - Waddingtons 'JIMMY'. Brand new models in full working order, but without plastic peripherals, stickers etc. **£5.00**

COMPONENT PACKS

K560 Semiconductors - Over the years we have purchased many transistors, diodes, ICs etc. which for one reason or another have accumulated in one of our stock rooms. Rather than spend weeks sorting and listing them, we have decided to make them into packs. All components are full spec marked devices. Some may be coded. We believe this to be one of the best value packs ever offered, as many high value components are included. Packs are made up by weight; this means contents are very approximate - if there are several bulky power devices, there will be considerably fewer parts than those packs containing all small signal items.
Pack of approx 100 **£5.50**
Pack of approx 250 **£12.00**
Pack of approx 1000 **£40.00**

K539 Led Pack - not only round but many shaped leds in this pack in red, yellow, green, orange and clear. Fantastic mix.
100 **£5.95** 250 **£13.50**

K547 Zener Diodes - Glass and plastic, 250mW to 5W ranging from 3V to 180V. All readily identifiable. 100 for **£4.50**

K546 Polystyrene/mica/ceramic caps - Lots of useful small value caps up to about 0.1µF in voltages up to 8kV. Good variety. 100 **£2.75**

K528 Electrolytic Pack - All ready cropped for PCB mounting, this pack offers excellent value for money. Good range of values and voltages from 0.47µF to 1000µF. 6V to 100V
100 **£3.95** 250 **£8.95** 1000 **£32**

K518 200 Disc Ceramic Caps - Big variety of values and voltages from a few pF to 2.2µF, 3V to 3kV **£1.00**

K530 100 Assorted Polyester Caps - All new modern components, radial and axial leads. All values from 0.01 to 1µF at voltages from 63 to 1000V!
Super value at **£3.95**

DIL SOCKETS

Must clear excess stocks - 1/4 million low profile top quality IC sockets to dispose of!

Pins	10	100	1000
8	40p	£3.00	£20
14	68p	£5.10	£34
16	72p	£5.40	£36
18	76p	£5.70	£38
20	80p	£6.00	£40
22	84p	£6.30	£42
24	88p	£6.60	£44
28	92p	£6.90	£46
40	96p	£7.20	£48

'D' CONNECTORS

	15W	25W	37W
R/A plugs	40p	50p	60p
R/A skts	50p	60p	70p
W/W plugs	40p	50p	60p
W/W skts	50p	60p	70p
S/P plugs	40p	50p	60p
S/P skts	50p	60p	70p

All top quality gold plated

Z345 OPTICAL SHAFT ENCODER. Similar to RS631-632, but 80% cheaper! **£8.50**

SEMICONDUCTORS

Hundreds in Cat - look at these sample prices:
LM317K £1.00; 68008L8 £3; 27C256-25 £5; 68A00 £1.20; LM223K £3; DL1416 £7; RBG1000 £1.20; DL3416 £8; 555 20p; 741 20p; 74LS240 25p

K520 Switch Pack - 20 different assorted switches - rocker, slide, push, rotary, toggle, micro etc.
Amazing value at only **£2.00**

K569 Reed Switch Pack. A selection of about 15 types of reed switch from submin 12mm long to 5A rated 50mm long, mostly form A (make), few form C (Change-over).
Pack of 30 **£2.75**

K540 Resistor Pack - mostly 1/8, 1/4 and 1/2W, also some 1 and 2W in carbon, film, oxide etc. All have full length leads. Tolerances from 5 to 20%. Excellent range of values. 500 **£2.50** 2500 **£11.00**

K503 100 Wirewound Resistors - From 1W to 12W, with a good range of values. **£2.00**

JOYSTICKS

Z004 Skeleton Joystick, switch type. Good quality, made by AB. Brass spindle has 44mm long black plastic handle attached. Body has 4 mounting holes. These really are a fantastic bargain! **Only £1.00**

Z8831 Dragon Joystick. Made by Dragon Data. Hand-held with fire button. 2m lead with 5 pin DIN plug. Uses 2 x 100k pots. **£3.00**

Z615 BBC Joystick. Internal resistors give the required voltage levels. 2 fire buttons. Rubber suction feet. 120 x 110 x 155 **£3.00**

POWER SUPPLIES

Z975 Cased PSU 92x57x45mm with built-in 13A mains plug. Output 14V ac @ 600mA. **£3.00**

Silicon mains PSU 62x46x35mm with built-in cont. 2 pin plug. Output 4.5V DC 100mA to 3.5mm plug **ONLY £1.00**

Z4113 BBC Computer PSU (early models). Steel case 158 x 72 x 55mm, 2m long mains lead, rocker switch, fused. Outputs: +5V at 2.5A; -5V at 100mA **£3.95**

KEYBOARDS



Z8852 Keyboard: Superb brand new keyboard 392x181 with LCD displaying 1 line of 10 characters & a further line with various symbols. 100 keys, inc separate numeric keypad. Chips on board are 2x74HC05, 80C48 **£15.00**



Z8848 Alphanumeric plus separate numeric keyboard. 104 keys plus 11 chips. 442x175mm. **£12.00**

Z4116 24 way (8 x 3) membrane keypad. Large (200 x 90mm) area - they were used in a teaching aid. Overlay template and pinout supplied. **£3.00**

Z810 KEYBOARD Really smart alpha numeric standard qwerty keyboard with separate numeric keypad, from ICL's 'One Per Desk'. Nicely laid out keys with good tactile feel. Not encoded - matrix output from PCB taken to 20 way ribbon cable. Made by Alps. Size 333x106mm. 73 keys **£8.95**

COMPUTER KEYBOARD **£4.00**
Yes, only £4 for this Cherry keyboard - 67 full travel keys inc. function keys. Size 340x130mm. Pale/dark brown **£4.00**

Z8863 KEYBOARD - High quality by Microswitch. 69 keys, 6 LED's, 15 various LS chips + socketed D8048 by Intel. Output via 7 way plug. Size 317x170mm **£12.00**

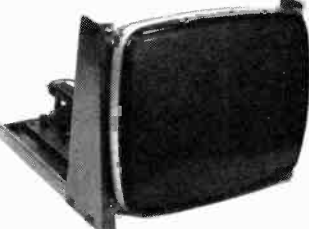

GREEN SCREEN HI-RES 12in MONITOR CHASSIS

Brand new and complete except for case, the super high definition (1000 lines at centre) makes this monitor ideal for computer applications. Operates from 12V d.c. at 1.1A. Supplied complete with circuit diagram and 2 pots for brilliance/contrast, plus connecting instructions. Standard input from IBM machines, slight mod (details included) for other computers **Only £24.95+£3 carr.**

MONITOR INTERFACE KIT

Enables our hi-res monitor (above) and most others to be used with virtually any computer, PCB **£3.00**
Complete set of on-board components plus regulator and heatsink **£9.95**
Suitable transformer for interface and above monitor **£5.31**

Z8837 DUAL SHEET FEEDER.

Brand new breakdown unit. Contains 3 x 12V stepper motors (48 step) plus driver panel with 4 x TIP115, 4 x TIP110, LM3302, 2 x 7407; 2 solenoids, buzzer, microswitches, control panel, 2 photocouplers plus lots of gears and mechanical bits. **£24.95+£3 carr.**

Z8862 10 game video unit - 2 hand held controllers with joysticks, beautifully made. Requires 7.5V DC input (suitable PSU £2.95). Composite video and sound outputs (modulator + wiring details for direct connection to TV £6) **£9.95**

Z8858 Hitachi Video Battery Charger BC60U for DP600 batts used in GP7 camera. Extremely high quality unit. **£17.00**

NOTICE TO RETAILERS

Greenweld Electronics Ltd. have been appointed Official Wholesalers of Verobloc, Verobroad, Easiwire and Accessories by Vero. We will be only too happy to supply all your Veroboard requirements at Trade Price. Ring, write or fax us for full information and prices.

GREENWELD ELECTRONIC COMPONENTS



443C MILLBROOK ROAD, SOUTHAMPTON, SO1 0HX.

All prices include VAT; just add £1.00 P&P; Min. credit card £5. No CWO min. Official orders from schools welcome - min invoice charge £10.00. Our shop has enormous stocks of components and is open 9-5.30 Mon-Sat. Come and see us!
HOW TO CONTACT US

By post using the address below: by phone (0703) 772501 or 783740 (ansaphone out of business hours); by FAX (0703) 787555; by EMail Telecom Gold 72:MAG36026; by Telex 265871 MONREF G quoting 72:MAG36026

Investigation 4

The DIY memory

Breadboarding the memory circuit is a challenge for those who like finishing up with a bird's nest of connecting wires. This investigation is strictly for the enthusiastic. If you are feeling faint-hearted at the prospect, the next investigation is much less demanding!

The circuit requires more room than usual (Fig. 17). It is best to begin by wiring up the buffers and their control gates – the three ics on the right of Fig. 17. Check that these operate properly before completing the circuit with the NOR gates and latch ic.

This version of the circuit has two leds to indicate the state of data input or output. To read and store data, follow the steps listed in the previous section. When you are reading data, do not have the D₀ and D₁ leads plugged in, as this over-rides the true data output.

Investigation 5

The 2114 memory chip

This ic (Fig. 18) contains all the circuit elements of Fig. 17 and a lot more beside. Instead of storing four bits, the 2114 stores 4096 bits. Its addressing system provides for 1024 words, of four bits each. It is a good example of the power of large scale integration.

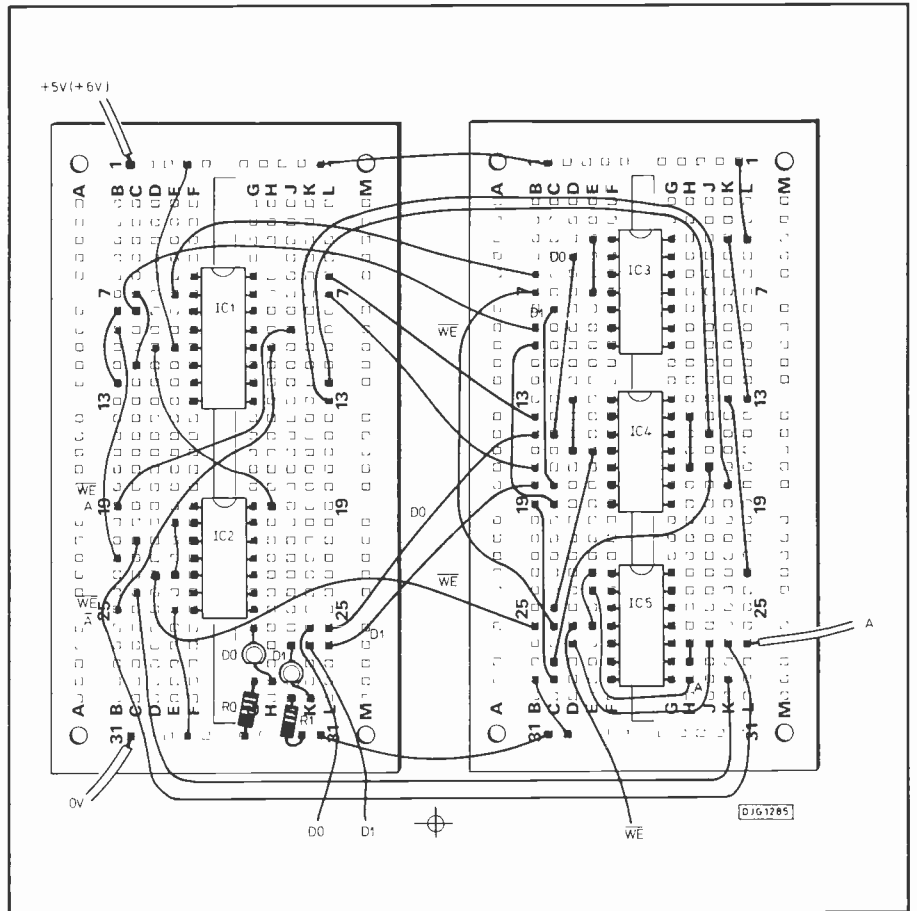

Fig.17. Breadboard version of the DIY memory

DIGITAL ELECTRONICS

BY OWEN BISHOP

PART 8 – MORE COMPUTER LOGIC

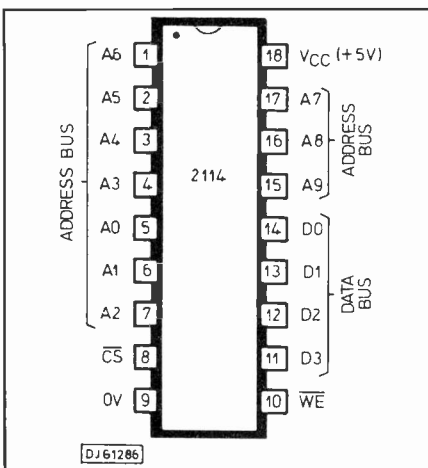

Fig.18. The 2114 memory chip

In order to write or read to 1024 different addresses we need ten address bits. Addresses range from 00 0000 0000 to 11 1111 1111 (0 to 1027 in decimal or 0 to 3FF in hexadecimal). There are four data input/output terminals. The WE input has the same function as in our diy memory. There is an extra control input, CS. This is

the *chip select* input. A computer needs more than just one 2114, so this input is used to bring this particular ic into action when required. When CS is high, the chip

Owen shows more practical ways in which you can learn the basics of computer hardware, concluding with simple circuits for a 2-bit adder, awd, frost alarm and weighted dice.

is, in effect, disconnected from system. When it is low, data may be written or read.

Wire up Fig. 19 to see how the memory works. CS is connected permanently to 0V so that the chip is enabled. To write data:

- plug WE into the +5V line (read)
- set up an address by plugging A₀ (lsb)

to A₉ into the +5V or 0V lines. You have 1024 addresses to choose from. To prevent yourself from becoming too tangled in a maze of wires, it is best to connect A₃ to A₉ permanently to 0V. Just work with A₀ to A₂. These give you eight addresses, which is ample.

- set up the data by plugging D₀ to D₃ into the +5V or 0V lines. You can set up any value from 0000 to 1111. The data you are writing is displayed on the leds.

- Make WR low. Then make it high again. The data is now written into the latches in the chip.

- You are now in read mode. Remove the data leads from the supply lines. The leds now show what data is being read.

Store several different values at different addresses. You can then read the data from these addresses. Try not to disturb the wiring more than necessary. You may generate 'spikes' on the supply line, which could cause stored data to be lost or altered. Normally, the data remains at each address until it is altered by you, or the power is deliberately switched off.

Keep this ic wired up, as we shall use it again later.

OTHER MEMORIES

The memory chip that we have just been working with is known as *random access memory*, or ram. There are two types of ram. The 2114 is one of the type known as *static* memory. Static memory, once written to, holds its contents until they are altered or the power is switched off. The other type of ram is known as *dynamic* memory. This does not hold the data indefinitely. This is because the data is not stored in flip-flops but in tiny capacitors. The capacitors are either charged or not charged, depending on whether they have been written with 1 to 0. But the charge leaks away from the capacitors in two or three milliseconds unless it is *refreshed*. This operation has to be done repeatedly by circuits in the computer. When the chip is refreshed, every capacitor is tested before the charge has had time to leak away completely. Uncharged capacitors are left uncharged. Capacitors that have some charge remaining on them are recharged. All this has to be done in between the times allocated to the microprocessor for writing and reading.

Obviously dynamic ram is a lot more trouble to use. Its chief advantage is that, since capacitors are less complicated than flip-flops, it is possible to fit many more of them on to a chip. They cost less too. For about the same price as the 2114, storing 4096 bits, you can buy the 41256 dynamic ram which stores 262144 bits.

RAM is intended for temporary data storage such as programs loaded into the computer and later replaced by other programs, and data such as the results or calculations made while the program is running.

The other main type of memory is *read only memory*. This is intended for permanent data storage. It may store the programs of a computer's operating system, for example, or its built-in language. Or it may store frequently used programs such as a word-processors. The data in a rom is put into it when the computer is being manufactured. Or perhaps the owner buys a rom chip or a cartridge containing such a chip, and plugs it into a socket in the computer. There are several types of rom, differing in the way the data is stored:

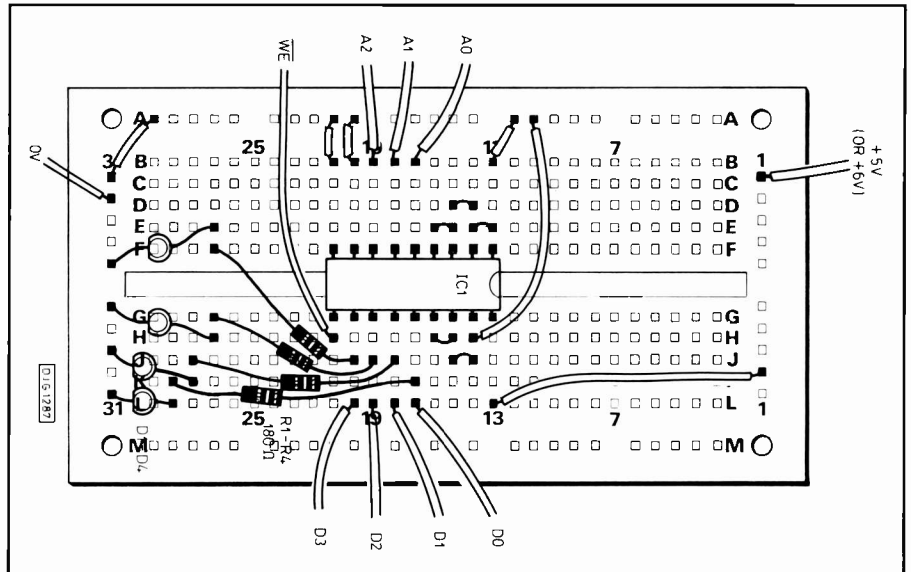

Fig.19. Breadboarding the 2114 memory chip

Mask-programmed:

This type is manufactured with the data already part of the chip design. The data can not be changed once the chip is made. It has to be specially made and is therefore expensive, except in large quantities.

Fusible link:

The chip is manufactured with all the bits set '1'. To set a bit to '0' it is addressed and then a high current is passed through the chip. This 'fuses' the addressed circuit units, converting the bit to '0'. Once this has been done the only change you can make is to turn more '1's into '0's, but not '0's into '1's. This type of rom is cheap to make. The only extra cost is the original programming.

Eprom:

The Erasable Programmable ROM is the most frequently used type of rom. The data is held in small capacitors, charged by applying a high-voltage pulse. Unlike static ram, the charge does *not* leak away rapidly as the capacitors are not electrically connected to the outside world. They retain their charge (and therefore the data) for hundreds of years. The charge is detected by the effect of its electric field, but this does not remove any of the charge itself. These chips are cheap to make and easy to

program. Their other advantage is that they can be altered. If you make a mistake when programming them, you can erase the program and start again. Erasing is easily done by shining strong ultra-violet radiation on the chip for about half an hour. This is why eproms have a quartz window (Fig. 20). The uv produces ions which discharge the capacitors.

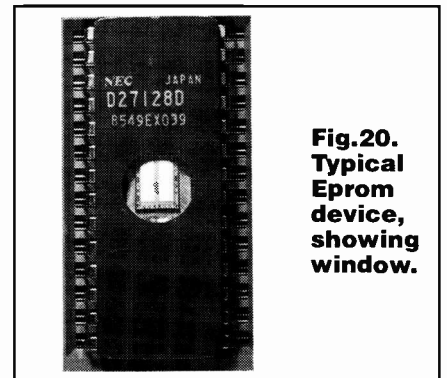
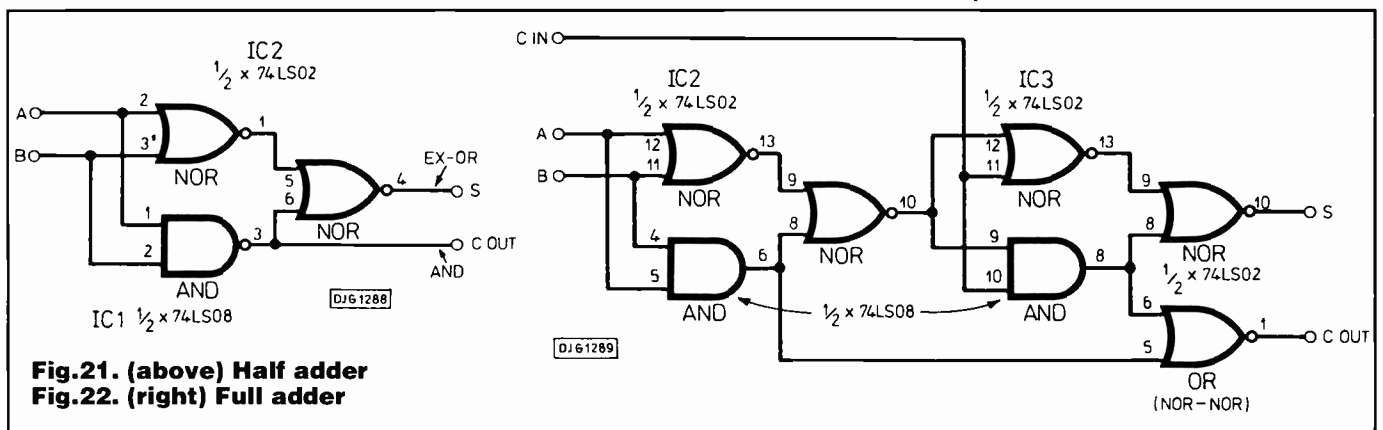

Fig.20. Typical Eprom device, showing window.

E²rom or Eerom:

The Electrically Erasable rom, or Electrically Alterable rom (earom), like the eprom, can be erased and reprogrammed as required. E²roms are much quicker than eproms to erase but are much more expensive.



**Fig.21. (above) Half adder
Fig.22. (right) Full adder**

Cd-rom:

Digital recording techniques need not be restricted to audio. A cd disc can also store large quantities of data and programs in binary form. It takes longer to read the data, since it is not possible to pick out any particular byte instantly, simply by calling up its address. But a cd player does not take more than a few seconds to find the required track and, once it is in position, can read a continuous block of data quickly.

MORE ELECTRONIC MATHS

We have seen how multiplication can be done. Now let's look at addition. In binary arithmetic there are only four possible addition sums:

Numbers to be added		Result	
A	B	Carry C	Sum S
0	0	0	0
0	1	0	1
1	0	0	1
1	1	1	0

Two single-bit numbers, A and B are added to give a single-bit sum S. When A=1 and B=1, the sum is 10 or '0, carry 1'. The table above looks like a truth table. What truth-table is it? It is really two truth tables in one. One is the truth table for A, B and S. S=0 when A and B are equal; S=1 when A and B are different. Those readers who were with us for Part 2 (PE Oct. 88) will recall that this operation is known as exclusive-OR. The other truth table is the table for A, B and C. This is the AND operation. The logic of binary addition can be done with just two gates, an EXOR and an AND. However, since we need the AND gate to get C, we can get the EXOR function from two NOR gates and the AND as in Fig. 21. (Work out the truth tables for yourself, to prove it!) This circuit adds two 1-bit numbers and produces the sum bit and the carry bit.

When we are adding numbers of 2 or more bits we need to allow for the carry-over from one stage to the next, as this example shows:

$$\begin{array}{r} 01 \\ +11 \\ \hline 100 \end{array}$$

Step 1:

Add the two least significant bits:
1 + 1 = 0, carry 1

Step 2:

Add the next two bits:
0 + 1 + 1 (carried over) = 0, carry 1

Fig. 21 can do step 1, but not step 2. It has no input for a bit carried over from a previous step. Fig. 22 shows a circuit that accepts a carry-in bit. Fig. 22 is called a full-adder, while Fig. 21 is only a half-adder. The full adder consists of two half adders; the first adds A and B, producing a sum and a carry; the second adds C_{IN} to the two half-adders are ORed to give C_{OUT}.

Fig.23. Breadboard layout of 2-bit adder

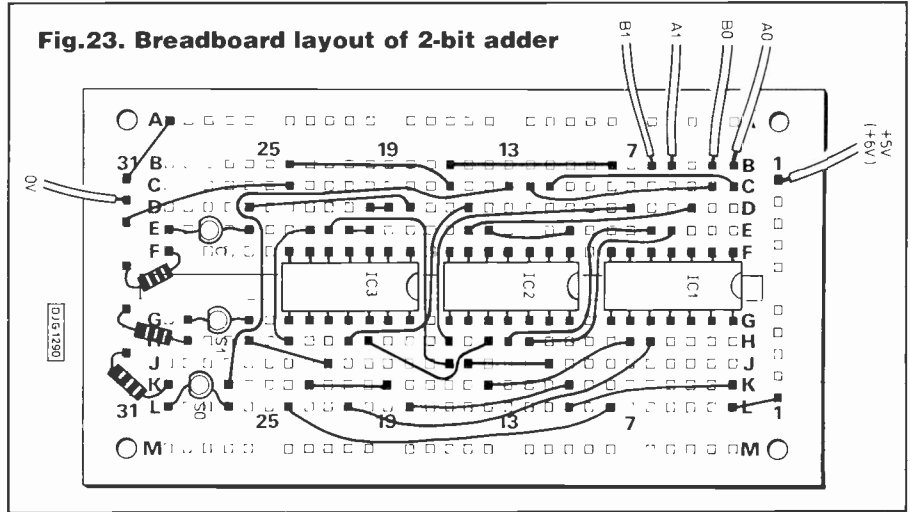

If we connect the C_{OUT} of Fig. 21 to the C_{IN} of Fig. 22, we have a circuit that adds two 2-bit numbers.

of this circuit becomes the C_{IN} of the extra adder. Now you can add two 3-bit numbers.

INVESTIGATION 6

A 2-bit adder

Fig. 23 shows a breadboarded version of Figs. 21 and 22. Instead of the single OR gate we make use of two NOR gates, since these are to spare in IC3. This circuit (with some of the gates swapped to simplify the wiring) is also featured as Module 11 this month. If you prefer, build the module and use it in this investigation.

The adder accepts two numbers A and B. A₀ and A₁ are the lsb and msb of a respectively, and similarly for B. The outputs appears as two sum digits, S₀ (lsr) and S₁ (msr), and a carry-out digit. Build the adder and try adding various pairs of numbers. What is the largest answer that it can produce? (Answer at end.)

You can extend the adder by connecting another full adder to it. The C_{OUT} output

MICROPROCESSORS

Last, but no means least, we come to the logic device that is at the centre of all microcomputers, the microprocessor. Microprocessors are also to be found in many other pieces of equipment that perform complicated operations, such as washing machines, computer printers, robots, video players etc.

The key section of the microprocessor (Fig. 24) is the arithmetic and logical unit, the ALU. Here is the logic that performs arithmetic operations such as adding and subtracting, and logical operations such as ANDing, and ORing. The alu operates on data stored in a special register called the accumulator. This is equivalent to a small pad of paper that you might use to jot down the various stages of a calculation that you are doing in your head. The alu corresponds to your head! You can think of the

Fig.24. Main parts of a microprocessor

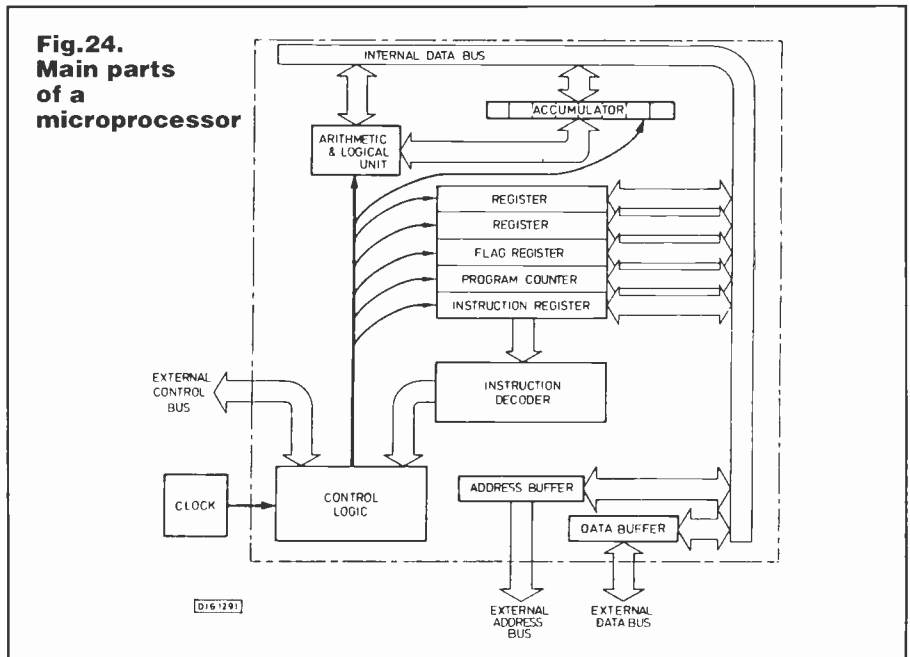

accumulator as a register rather like the shift register of Fig. 7 last month but with parallel loading and unloading. Its shifting facility is used for operations such as multiplication – though this is not the only way multiplication can be done. The accumulator is often an 8-bit register, though many microprocessors may have 16 bits or more in the accumulator and in other registers. Data from the accumulator may be taken to the alu, operated on and then returned to the accumulator. Data from the accumulator may also be taken along the internal data bus to the other registers. There are usually several general-purpose registers used for holding numbers that will be needed later. Data is stored in these until it is needed again. The other registers are:

Flag register:

This is used not for storing an 8-bit byte, but for single bits, each of which has a special meaning. For example, one flag bit is used to hold the carry bit from an addition. Another is set to 1 if the result of a calculation step is negative.

Program counter:

This tells the microprocessor at which address in memory the next instruction of the program is stored.

Instruction register:

The current instruction is stored here (more about instructions next month), and goes to a decoder to find out what has to be done.

The instruction decoder passes on the decoder instruction to the *control logic*. It is this section that sends data around inside the microprocessor from one register to another, tells the alu what to do with it, and calls up the next instruction when it is ready to proceed. It has connections to other parts of the microcomputer through a set of lines known as the *control bus*. Data is sent from one part of the microprocessor to another along an *internal data bus*.

At bottom left in Fig. 24 is the *clock*, an astable which produces pulses at a high rate (several megahertz). This times the operations of the microprocessor and ensures that its action is synchronised both internally and externally (for example, so that the microprocessor does not try to read or write to dynamic memory while it is being refreshed). The clock is usually a separate ic, not part of the microprocessor.

Data is sent to other parts of the computer along the *data bus* (more about

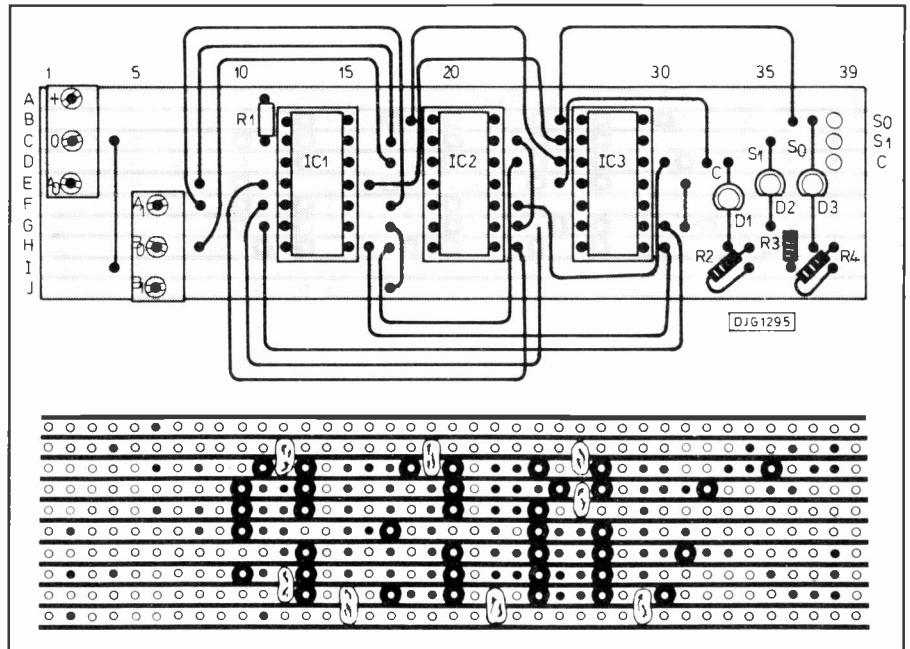

Fig.25. Module 11. 2-bit adder

this next month). There are tri-state buffers between the external data bus and the internal data bus. There is also a buffer for the address bus, another topic for next month's discussion.

numbers? What logic gate calculates the carry bit?

14. Why is a half-adder so-called?

15. Which part of a microprocessor does the arithmetic?

16. Which is the main register used for calculations?

17. What is the purpose of the internal data bus of a microprocessor?

18. Which register keeps a note of how far the microprocessor has got in its program?

19. Where in a microprocessor would you look to find the bit carried over from an addition.

20. What does the instruction register do?
The answers are on the next page.

SELF-TESTING

1. Name three logical circuits that can be built up from D-type flip-flops.
2. What input is needed to make a D-type flip-flop change state?
3. What is the difference between a siso shift register and a sipo shift register?
4. What types of shift register would you use for sending data along a transmission line?
5. How many shifts are needed to multiply 7 by 16? What do the bits look like before and after shifting.
6. What is the difference between a register and a latch?
7. What are the three output states of a tri-state buffer?
8. What does WE mean?
9. What factors can alter the data stored at a memory address?
10. What is the difference between ram and rom?
11. How is data held in an eeprom?
12. How is data erased from an eeprom?
13. What logic gate is used to calculate the 1-bit sum (S) of two 1-bit binary

MODULES OF THE MONTH

A 2-bit adder

This is based on Fig. 23, though the pin connections are different, so as to adapt the wiring for stripboard (Fig. 25). The two 2-bit numbers added are A_1A_0 and B_1B_0 . Their sum (S_1S_0) and carry (C) are indicated by three leds. There are three terminal pins on the right, for connecting to other circuits (see the second System of the Month). The module requires a maximum current of 30mA.

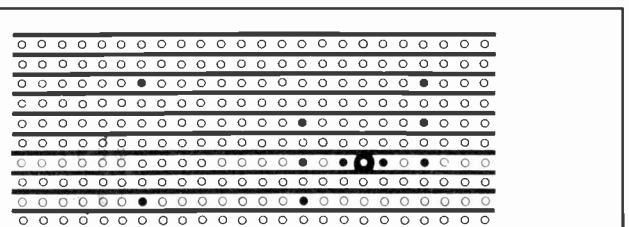
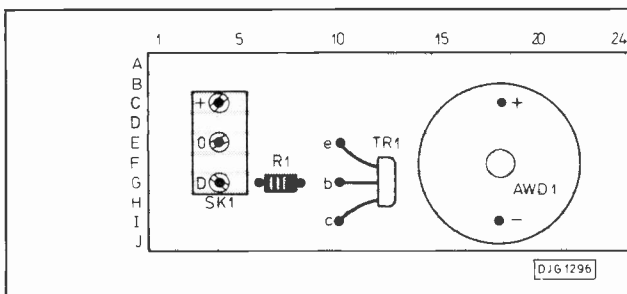

Fig.26. Module 12. Audible warning device

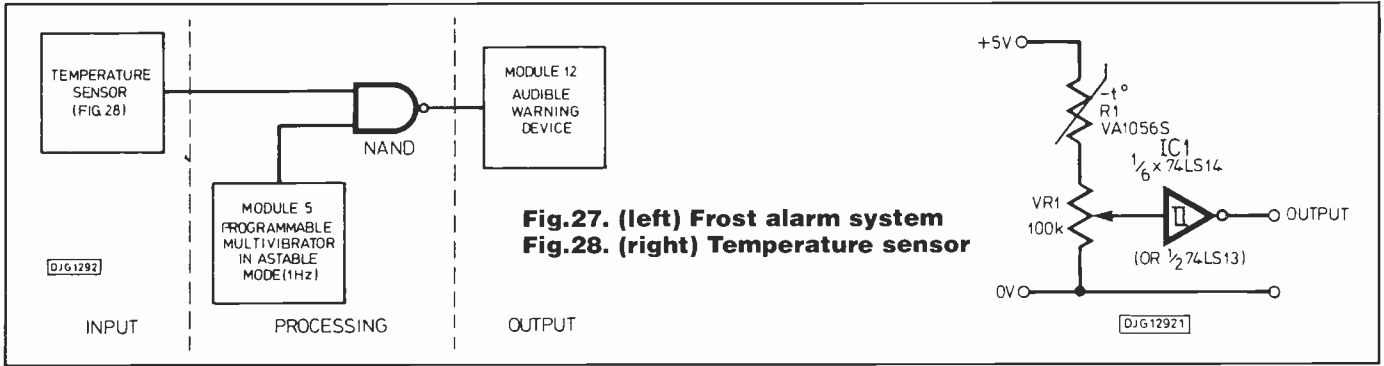

Fig.27. (left) Frost alarm system
Fig.28. (right) Temperature sensor

Parts required:

- R1 1k carbon 5%
- R2-R4 180 ohm carbon 5% (3 off)
- IC1 74LS08 quadruple 2-input AND gates
- IC2,IC3 74LS02 quadruple 2-input NOR gate (2-off)
- D1-D3 TIL209 or similar leds, 2 red (sum), 1 yellow (carry)
- 1mm terminal pins (3 off)
- SK2,SK2 pc terminal 3-way (2 off)
- 14-pin dil socket (3 off)
- Stripboard 10 strips by 39 holes

Audible Warning Device

A useful output interface (Fig. 26) for alarm systems, warning of circuit malfunction etc. The awd is any of the solid-state devices or buzzers that produce a tone when a current is passed through them (Note: NOT the piezo transducers, which require an astable to generate the tone). Operating voltage should be in the range 3-12V. Although many of these devices can be driven directly from a logic gate we use a transistor switch here. This reduces the drain on the logic to only a few microamps. High input activates the awd. The module requires 2mA when activated.

Parts required

- R1 47k carbon 5%
- TR1 ZTX300 npn transistor
- AWD1 audible warning device (see above)
- ST1 pc terminal 3-way
- Stripboard Vero 14345

27). The sensor consists of the thermistor and variable resistor connected as a potential divider (Fig. 28). The input to the Schmitt trigger gate falls as temperature falls. Eventually the gate output changes from low to high. When the gate output is high, the pulses from the astables pass through the NAND gate, and invert and activate the awd. An intermittent warning tone is produced.

Weighted Dice

This is an electronic dice system for use in games (Fig. 29). It is weighted, but that does not mean it is unfair. If you shake a pair of ordinary 6-sided dice, you will rarely score 2 (double 1) or 12 (double 6). Score 7 is the easiest to obtain because you can get it from 1+6, 2+5, 3+4, 4+3, 5+2 and 6+1. In this system the counter output is used as if it is two 4-sided dice. It is hardest to score 0 (double 0) or 6 (double 3), and easiest to score 3 (0+3, 1+2, 2+1 and 3+0). This is what we mean by saying it is weighted. The astable runs fast, running the counter through from 0 to 15 too quickly for anyone to see the score. When you press the button, the stream of pulses from the astable is interrupted. The counter halts. Its upper two bits are taken to represent a score of 0 to 3 on one die. The lower two bits represent 0 to 3 on the other die. The adder totals these two scores and presents you with the answer - 0 to 6. An optional extension to the system sounds an awd if you score double-3.

ANSWERS TO QUESTIONS

Investigation 6:

The largest answer produced is 110, the sum of 11 and 11.

Self-testing

1. Counter, storage register, shift register.
2. A positive-going (rising) edge triggers the 7474 D-type flip-flop.
3. SISO has only serial input and output. SIPO has parallel output as well.
4. PISO at the transmitting end SIPO at the receiving end.
5. Four shifts, starts as 00000111 (=7), finishes as 01110000 (=112).
6. The output of a register is fixed until the clock goes from low to high. Then the output changes to the new data. The output of a latch follows the input data (the latch is transparent) as long as the clock input is high. When the clock goes low, data present at the output is held latched until the clock goes high again.
7. High (1), low (0) and high-impedance (in effect, disconnected).
8. Write enable. Writing is enabled when this line is low.
9. New data being stored there; 'spikes' on the supply line; power being switched off.
10. RAM is temporary data storage that can be freely written to, and read. ROM has data stored in it before it is installed in the computer.
11. In capacitors that are charged or not charged.
12. By exposing the chip to strong ultra-violet radiation.
13. Exclusive-OR; AND.
14. It does not allow for a carry-in bit.
15. The alu, arithmetic and logical unit.
16. The accumulator.
17. Carrying data from one register to another, or to the alu, or to the buffers.
18. Program counter.
19. In the carry bit of the flag register.
20. It holds the instruction that the microprocessor is currently performing. **PE**

SYSTEMS OF THE MONTH

Frost Alarm

This sounds an audible alarm when the temperature falls below a given level (Fig.

DID YOU KNOW?
Owen Bishop is the author of numerous books on electronics and allied subjects and has been a frequent contributor to the monthly magazines in the field for many years.

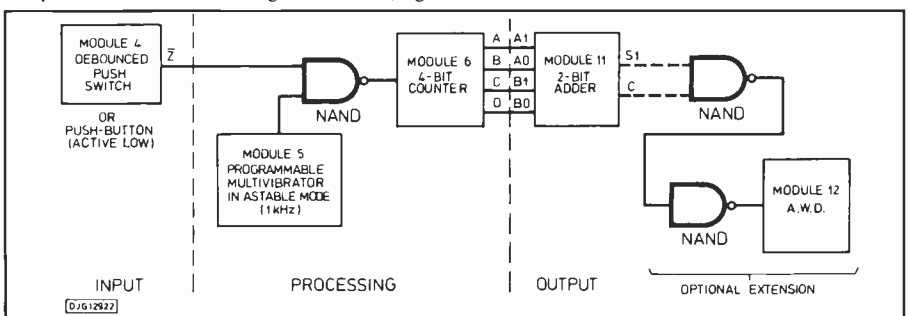
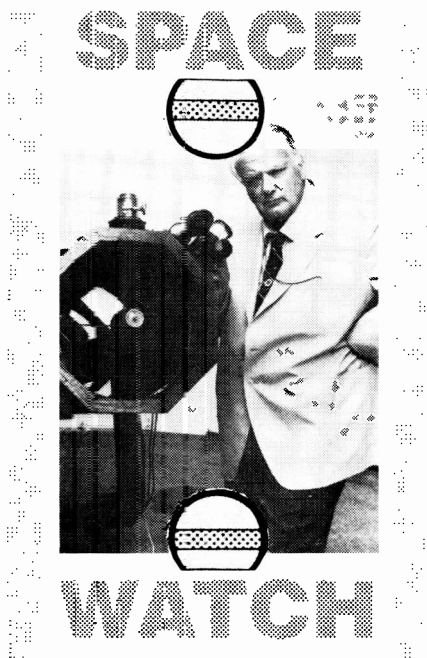

Fig.29. Weighted dice system

NEXT MONTH:
Owen looks at computer systems, their architecture, input-output functions, and drives a bus!

Astronomy has been revolutionised by electronic devices, notably the ccd or charge-couple device, developed largely by a British team at Herstmonceux led by Professor Alec Boksenberg. (We ran a report on them in *PE Sep 88, Ed.*) Using a ccd together with the 2.2-metre telescope at La Silla, the Chilean observatory run by the Europeans, three astronomers – H.E. Schwarz, C. Aspin and J.H. Lutz – have made important studies of a faint object which may be unique. It is too far south to be seen from Britain (it lies in the constellation of Centaurus) and has the unexciting designation of He 2-104. It may well be the first object to be observed in a state of transition from one state to another.

There are some pairs of stars, physically associated, which are known as symbiotic stars in which the two components are interacting. Some of these are surrounded by envelopes of gas, others by envelopes of dust. He 2-104 seems to be of the 'dusty'



broken up – though the demise of Phobos is by no means imminent! (Deimos, the smaller and outer satellite, seems to be safe.)

Last July the Russians sent two probes to explore Phobos. One of these was lost when it was given a faulty command from the ground station – a case of human error; efforts to locate the probe from the La Silla Observatory failed, and the chances of finding it again now seems to be virtually nil. This leaves Phobos 2, which will – we hope – hover at a height of no more than 50 metres above the surface of the satellite, making analyses of the soil elements, rock structure and so on.

MAPPING MISSION

By the end of January, Phobos 2 had reached the neighbourhood of Mars, and a braking manoeuvre put it into an orbit round the planet. One of its first tasks has

PROBING SOLAR SYSTEMS

BY DR PATRICK MOORE CBE

In Chile, astronomers are observing an event which is probably unique in our time – a star hatching into a solar system. And the Russians are looking for life on Mars.

The William Herschel Telescope at Las Palma. Photo by courtesy of R.G.O.

variety, but it has sent out what look like arms and blobs; the blobs are moving away from the small, hot, central star at around 100 kilometres per second. Probably it is about to shed its outer layers, in which case it will turn into an object of the kind known, misleadingly, as a planetary nebula. If this transition stage lasts for only a thousand years or so, we are lucky to have caught He 2-104 "in the act".

One of Russia's leading rocket technicians, Valentin Petrovich Glushko, has died at the age of 80. He was the man behind the creation of the rocket engines which were, in the 1950s, the most powerful in the world, and enabled the Soviets to launch their initial massive payloads. He was associated with Sergei Korolev, probably the most brilliant of all the Russian pioneers of space-flight, and was able to rescue Korolev when he had run foul of the Stalin régime and had been imprisoned. In 1974, Glushko took over Korolev's design team, as General Designer of Manned Space-ships and Space Stations, so that he was deeply involved in the planning and construction of the Mir station now orbiting the Earth.

THE PHOBOS PROBE

Phobos, the inner satellite of Mars, has come in for a great deal of attention lately. It is a curious little body, irregular in shape and with a longest diameter of less than 30 kilometres, so that it is quite unlike our massive Moon. It also seems to be in an unstable orbit, gradually spiralling down toward Mars, so that it will eventually crash on to the surface even if it is not previously

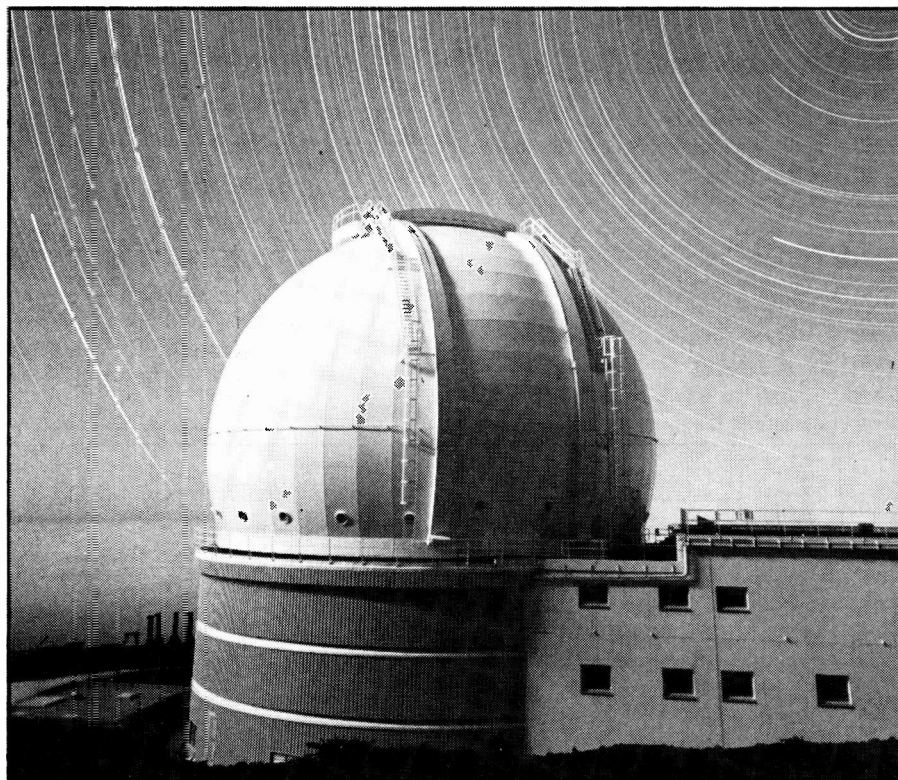

been to begin making a temperature map of the Martian surface, and study the materials present there: it seems that the Russians have not finally given up all hope of finding some sort of organic material ("life"), though it is clear that even if Mars is not completely sterile, any living organisms there must be very lowly indeed.

However, Phobos is the main target for this particular probe, and one is bound to ask just why the concentration is upon the tiny satellite rather than on Mars itself. The

reason is that so far as we can tell, Phobos is typical of the very small members of the Solar System. It may well be a captured asteroid; after all, Mars is much closer to the main asteroid zone than we are. But for the *Challenger* disaster, the Americans should have obtained the first close-range asteroid pictures by now (en route to Jupiter, the Galileo probe was to have imaged the asteroid Amphitrite), but as things are the Russians seem ready to be first in the field.

Small though Phobos is, it could well be of tremendous importance in the future. Manned missions to Mars are being planned, and Phobos seems to be a perfect natural space-station: it is close to Mars – only about as far above the Martian surface as we in Britain are from Aden – and its gravitational pull is so slight that a "landing" there will be more in the nature of a docking. So Phobos, and Deimos too, may have a major rôle to play in our exploration of the Red Planet. **PE**

THE SKY THIS MONTH

For planetary enthusiasts, the main target this month will be Mercury, which is in the evening sky and should be easily visible with the naked eye. For the second part of April it will set well after the Sun, so that this is the most favourable opportunity for some time to come. At maximum brightness, on the 14th, the magnitude is -1.4, just about the same as that of Sirius, though of course Mercury is never visible against a dark background. Telescopes will not show much – almost all our knowledge about Mercury has been derived from one space-probe, Mariner 10 – but it is always a source of satisfaction to locate this quick-moving, elusive little planet.

Venus is out of view (it passes through superior conjunction on April 4, so that it is on the far side of the Sun). Mars passes from Taurus into Gemini, and is in the evening sky, but has now faded to well below the first magnitude; Jupiter remains brilliant in the west for some time after dark, and Saturn, still in Sagittarius (the Archer) is coming into view well before dawn. The rings are wide open, so that even though the planet is low in the sky even a modest telescope will show the ring-system easily.

The Moon is new on April 6, and full on the 21st. There are no solar or lunar eclipses this month. There is, however, one meteor shower; the Eta Aquarids are active from about April 24 to May 20. They are associated with Halley's Comet, and may have a ZHR of as high as 35 (that is to say, a naked-eye observer with the radiant at the zenith could expect to see 35 Eta Aquarids per hour).

We have now lost the brilliant winter constellations, such as Orion; instead, the southern aspect of the sky is dominated by Leo (the Lion) and Virgo (the Virgin). The Great Bear is high; the "tail" points to the brilliant orange Arcturus, and the curved line joining the Bear with Arcturus will, if continued, lead on to Spica in Virgo. Lower in the south there is a rather blank area: this is filled by Hydra (the Watersnake) which has only one fairly bright star. The W of Cassiopeia is at its lowest, in the north, though over Britain it never sets; Capella is descending in the west, Vega gaining altitude in the east. Deneb, in Cygnus, has also risen, but we have yet to see Altair in Aquila (the Eagle), the third member of the unofficial "Summer Triangle".

Do not miss a single issue of **Astronomy Now**



Britain's leading astronomical magazine

Edited by well known astronomer and regular contributor to *Practical Electronics*
Dr. Patrick Moore CBE

Place a regular order with your newsagent or for £15-00 (overseas £18-00) take out an annual subscription from Intra Press, Intra House, 193 Uxbridge Road, London W12 9RA

LOW ORBIT

A recent survey indicates that the public are likely to be slow in installing satellite tv receiving equipment for Sky and BSB transmissions. Whereas Sky forecast sales of 1 million aerials during 1989, and BSB expect 3 million by 1991, a report by Logica, a software and consultancy company, predicts that the total homes receiving satellite tv by the end of 1991 will only be between 1.6 and 2.2 million.

Looking on the brighter side, the survey suggests that by 1996 more than 7 million homes will be suitably satellite-equipped. Personally, I am waiting for tv manufacturers to produce sets and aerials capable of tuning to all satellite channels before I enter the viewing arena.

Hobbyline

Now available free to hobbyists, – Latest stock listing
INCLUDING

Receiving Valves, Rectifiers and Diodes, Thyristors and I.C's Plus a selection of discreet semi conductors for your listing

Either phone (0375) 360062

OR

Send a large S.A.E. to: Compstock (Hobby) Electronics, Compstock House, London Road, Stanford Le Hope, Essex, SS17 0JU

COMPSTOCK

The January Winter Consumer Electronic Show (CES) in Las Vegas was a frost – not so much in temperature, but in content. The swarms of electronic press reporters were all asking each other if they had seen anything new. Four long days of blah.

To give you an idea of how dead the event was, the biggest news was the Nakamichi, announcement that they were going to start selling a consumer \$10,000 dat recorder in the US. Other than some smirks at the concept of the Record Industry Association of America (RIAA) carrying out their threat to haul any firm trying to sell a dat recorder into court, the ripple effect was small.

CANNED LAUGHTER

One wonders how much record company money the RIAA would be willing to spend on such a frivolous suit. Going into court and asserting that a \$10,000 dat recorder is going to destroy the record industry might tend to make them even more of a laughing stock than they already are.

STATE

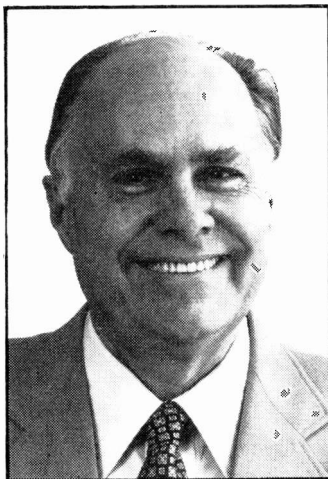

SIDE

did their best to convince the attendees that their particular speaker was the best. They did prove that if you put good speakers into small boxes, they'll sound pretty good – as long as you don't have something right there in a larger speaker for comparison. As is obvious from boombox sales, the human ear can get used to almost anything.

TWEEDS RUMBLED

The LP tweeds were there. Yes, there are still a few people who believe that lps sound better than cds. Any cds. Sigh, I twit them, saying, yes, they're probably right, but of course my lp player has a 100-pound turntable with adjustable balance weights around the rim to assure a steady speed – each lp is individually centered to eliminate wow – the table is lamentably sprung to avoid feedback – driven by belts to avoid rumble – has a vacuum suction to hold the lp tight – a special cushion to reduce the needle bounce – the whole works is in a special class 10 clean cabinet to avoid dust – and so on.

VAGUE GAMBLING AT VEGAS

Several members of congress were assembled, where they repeated the message we've had from two previous CES congressional panels; the record industry needn't look to congress for any action until they can prove actual losses. No more yelling wolf.

The Nakamichi entry, in addition to its amusing price, had one other interesting aspect: it will record at the previously verboten 44.1kHz sampling rate, thereby enabling it to make direct digital copies from cds – the ultimate horror for RIAA. Heh, heh.

DAT hasn't made much headway in Europe or Japan, I suspect because the systems have been blocked from the 44.1kHz cd standard.

The early dat systems were priced for people who have to have the latest technology – and can afford to pay for it. But one hears rumours of \$300 dats being readied for manufacture, once things get moving.

AUTO-DESTRUCT?

There's a chicken/egg problem with prerecorded digital tapes. Without players, record stores won't stock the tapes. And, many industry insiders believe, without prerecorded dats, it's going to be very difficult to sell dat players – particularly for cars, where they are needed the most. Car cd players are okay, but they do skip on the bumps, and it's difficult to change discs while driving. Yes, I know about the cd car jukeboxes. I also know what they cost.

As I wandered around the enormous halls at CES, I was reduced to numbness by the endless recitations of "exciting" features which the new models of everything sported. The Pitchmen spluttered when I asked them what the benefits of these exciting new features were. Did all these new features mean that

BY WAYNE GREEN
THE WCES 89 RETORT!

Consumer electronic shows can be a bore. Or they can be a laugh. Or they can be so boring, you have to laugh. But no cheap cd? That's not funny.

serious faults in their earlier products had been discovered and had now finally been surmounted? This confused them.

HI-D BOOMBOXING

There were a few high definition tv demos. Yep, sure looks great! But with so much money at stake, the infighting over standards is going to be fierce and could possibly lead to the industry's self destruction. Would quad sound have lived if there had been one standard format? Would vcrs have been accepted several years sooner if we hadn't had the Beta/VHS war? Something akin to quad sound is sneaking back via surround-sound encoded movies on video tapes.

The high end audio exhibitions were in the Riviera Hotel. There a hundred or so makers of almost identical, expensive, small speakers

I was disappointed that the outfit which promised the laser arm for playing lps showed only a hand-made sample, and announced that they were not going to actually market the players. Dam. My life is so full of disappointments.

The biggest disappointment of the show was the lack of record companies exhibiting. Dozens of people stopped by my CD Review booth to lament records not being there, in years gone by Telarc had done a land office business selling thousands of their cds for \$10. CES clamped down on selling at the show, so the record companies dropped out. Might CES go the route of NCC, National Computer Conference, once the biggest of all American computer shows and now defunct? Could be.

TOP POPS

VCRs and compact discs are still top selling consumer electronic products, so that's where most of the CES action was, even if the new products were comparatively boring.

Of course, in Vegas there's always the gambling. Casinos and slot machines are everywhere. The dream of something for nothing dies hard in man and is the secret of Vegas' success. It takes stern moral fibre not to succumb to the beckoning slots. You never win on the first play, which means that from then on you're working just in the hopes of breaking even. The machines are computer controlled to egg you on, always giving back less than you've spent. They will inexorably drain you, as they have millions before you.

You'll notice that no one working the slot machines is smiling. They have nothing to smile about. They are grimly trying to recoup the ever growing deficit their fading hopes have triggered.

The next CES is in June at Chicago. After the excitement at Las Vegas, I can hardly wait.



CAN YOU ANSWER YES TO ANY OF THESE QUESTIONS:—

- 1) DO YOU PROGRAM YOUR HOME COMPUTER?
- 2) HAVE YOU INTERFACED YOUR HOME COMPUTER WITH A PERIPHERAL?
- 3) ARE YOU INTERESTED IN AMATEUR RADIO?
- 4) ARE YOU FAMILIAR WITH DIGITAL ELECTRONICS?
- 5) ARE YOU DOING A COURSE INVOLVING ELECTRONICS?

If you can answer YES to one or more of these questions, you should consider entering the Computer Servicing Industry.

Micro System Maintenance Ltd is an established national computer service company and prides itself on successfully training individuals to become service engineers. The company has an established Training School in Weston-Super-Mare for the provision of training in both technology and the repair of personal computers and peripherals.

The selected candidates will be provided with a company car linked to an attractive benefits package.

If you wish to know more please feel free to contact MSM at the following address.

MICROSYSTEM MAINTENANCE LIMITED
15 WESTMEAD INDUSTRIAL ESTATE
WESTLEA
SWINDON SN5 7YS
TEL: (0793) 616888

TRANSFORMERS

EX STOCK

12/24V or 12-0-12V 2 x 12V Secs				30/15V or 15-0-15V 2 x 15V Tapped Secs			
24V	12V	£	P&P	Volts available: 3,4,5,6,8,9,10,15,18,20,27,30V or 15-0-15V			
0.15	0.05	3.44	1.87	30V	15V	£	P&P
0.25	0.5	3.64	1.87	0.5	1	4.55	1.81
0.5	1	4.36	1.87	1	2	6.19	1.98
1	2	6.08	2.09	2	A	4	10.01
2	A	4	7.01	2	A	4	10.01
3	M	6	12.08	3	M	6	11.60
4	P	8	12.87	4	P	8	13.84
6	S	12	15.62	5	S	10	17.72
8	16	18.59	3.08	6	12	19.41	2.91
10	20	25.02	3.52	8	16	25.74	3.02
15	30	31.10	3.63	10	20	29.94	3.24
20	40	44.40	4.12	12	24	33.42	3.35
30	60	63.75	4.89	15	30	37.43	4.01
41	83	73.41	6.32	20	40	51.10	6.54

MAINS ISOLATORS				AUTOS			
Pri 120V x 2 or 220/240V or 415/440V. Sec 440V or 240V or 110V Centre Tapped				105,115,220,230,240V For step-up or down			
20VA	£ 8.33		2.50	80VA	1.92	£6.91	
60	13.60	p 2.69		150	10.03	p 2.09	
100	15.87	& 2.91		250	12.05	& 2.31	
200	22.49	p 3.52		500	19.05	p 2.75	
250	27.20	3.63	1000	34.03	3.68	6	12
500	41.91	4.23	1500	40.40	4.18	8	16
1000	76.01	5.33	2000	60.41	5.11		
1500	98.04	6.54	3000	102.72	6.32		
2000	117.96	6.54	4000	133.35	O/A		
3000	165.41	O/A	5000	155.28	O/A		
6000	353.43	O/A	7500	239.70	O/A		
			10kVA	283.23	O/A		

50/25V or 25-0-25V 2 x 25V Tapped Secs to give 5,7,8,10,13,17, 20,25,33,40,50, t/c or 20-0-20V or 25-0-25V				CASED AUTOS 240-115V 240V Cable Input, 3-pin 115V USA Socket Outlet			
50V	25V	£	P&P	20VA	£9.85		2.03
0.5	1	5.91	2.09	80	13.38	p 2.14	
1	A	2	7.91	150	17.34	& 2.58	
2	M	4	12.81	250	21.13	p 3.57	
3	P	6	14.82	500	34.66	3.57	
4	S	8	20.30	1000	48.65	5.00	
6	12	25.81	3.24	2000	86.70	6.13	
8	16	36.52	3.57	3000	124.46	O/A	
10	20	43.34	4.07				
12	24	51.87	4.29				

BARRIE ELECTRONICS LTD
TELEPHONE: 01-555 0228 (3 lines)

VARIABLE VOLTAGE TRANSFORMERS

INPUT 220/240V AC 50/60 OUTPUT 0-260V

200W 0.1 amp max £24.00 p&p £3.00 (£31.05 inc VAT)

0.5KVA 2.5 amp max £26.50 £3.75 (£34.75 inc VAT)

1KVA 5 amp max £34.00 £4.25 (£43.99 inc VAT)

2KVA 10 amp max £49.00 £5.50 (£62.68 inc VAT)

3KVA 15 amp max £65.00 £6.25 (£81.94 inc VAT)

5KVA 25 amp max £115.00

10KVA 50 amp max £190.00

15KVA 75 amp max £285.00

Carriage on request

3-PHASE VV TRANSFORMERS

Dual input 200/240V or 380/415V Star Connected 3KVA 6KVA 10KVA available. Phone for details

COMPREHENSIVE RANGE OF TRANSFORMERS-LT-ISOLATION & AUTO (110-240V Auto transfer either cased with American socket and mains lead or open frame type Available for immediate delivery.

ULTRA VIOLET BLACK LIGHT FLUORESCENT TUBES

4ft. 40 watt £10.44 (£12.00 inc VAT) Caller only

2ft. 20 watt £7.44 + £1.25 p&p (£9.99 inc VAT)

13in 10 watt £5.50 + 75p p&p (£7.19 inc VAT)

12in 8 watt £4.50 + 75p p&p (£6.04 inc VAT)

9in 6 watt £3.60 + 50p p&p (£4.72 inc VAT)

6in 4 watt £3.60 + 50p p&p (£4.72 inc VAT)

230V AC BALLAST KIT for either 6in, 9in or 12in tubes

£5.50 + 55p p&p (£6.96 inc VAT)

For 13in tubes £6.00 + 75p p&p (£7.75 inc VAT)

400 WATT UV LAMP & BALLAST

Complete £56.80 + £3.50 p&p (£69.35 inc VAT)

400 WATT UV LAMP

Only £28.00 + £2.50 p&p (£35.08 inc VAT)

175 WATT SELF BALLASTED BLACK LIGHT MERCURY BULBS Available with BC or ES fitting £18.65 inc.

12 VOLT BILGE PUMPS

Buy direct from the importers

500 GPH 15ft head 3 amp

£16.00 inc

1750 GPH 15ft head 9 amp

£19.25 + £2.00 p&p (£25.00 inc VAT)

EPROM ERASURE KIT

Build your own EPROM ERASURE for a fraction of the price of a made-up unit kit of parts less case includes 12in 8 watt 2537 Angstrom Tube Ballast unit pair of bi-pin leads neon indicator on-off switch safety microswitch and circuit £13.60 + 75p p&p (£18.40 inc VAT)

SUPER HY-LIGHT STROBE KIT

Designed for Disco, Theatrical users etc. Approx 16 joules. Adjustable speed £48.00 + £2.00 p&p (£57.50 inc VAT)

Case and reflector £20.00 + £2.00 p&p (£25.30 inc VAT)

SAE for further details including Hy-Light and industrial Strobe Kits.

WIDE RANGE OF XENON FLASHTUBES

Write Phone your enquiries

SOLID STATE RELAY

Single make will switch up to 250 V AC 10 amp operating voltage 3-32 V DC silent contactless opto-isolated. Fraction of maker's price £3.00 + 50 p p+p Total inc VAT £4.03

SPECIAL OFFER AC CAPACITORS

1.5 MFD 440V £2.00 5 MFD 440V £4.00

2 MFD 440V £2.50 5.4 MFD 280V £2.00

4.1 MFD 440V £3.50 6 MFD 660V £4.00

p+p 50p per unit plus VAT to be added to total

TORIN CENTRIFUGAL BLOWER

230V ac 2.800 RPM 0.9amp 130mm diameter impeller outlet 63 x 37mm overall size 195 x 160mm long Price £17.50 + £2.50 p&p (£23 inc VAT)

SHADED POLE GEAR MOTORS

In the following sizes

9 RPM 12 RPM 80 RPM 160 RPM 110V AC or 240V AC with capacitors (supplied) Price inc. VAT + p&p £12.65

GEARED MOTORS

Manufacturer's surplus new 38.3 RPM torque 35in reversible 115V AC incl start capacitor and transformer for 230 240AC. ideal garage doors etc. Only £16 inc p&p + VAT.

12 V DC COOLER EXTRACTOR FAN

New brushless motor 92mm sq. Total inc p&p + VAT £11.50

Suitable transformer for 240V AC operation. £5.20 + £1.00 p+p. Total inc VAT £7.13

57RPM 240V

Continuously rated reversible 60lb in Manufactured by GEC New ideal for garage doors, curtains etc incl capacitor Only £18.00 + £2.00 p&p (£23.00 inc VAT)

SOLID STATE EHT UNIT

Input 230 240V AC. Output approx 15KV. Producing 10mm spark. Built-in 10 sec timer Easily modified for 20 sec. 30 sec to continuous. Designed for boiler ignition. Dozens of uses in the field of physics and electronics, eg supplying neon or argon tubes etc Price less case £8.50 + £1.00 p&p (£10.83 inc VAT) NMS

COOLING FANS-BRAND NEW!

200/400V AC American Boxer 'Pewee' 7-bladed high efficiency cooling unit 80mm sq x 40mm deep 40cm approx £10.35 inc.

EX-EQUIPMENT FANS 120mm sq x 38mm deep in either 115V or 230V AC Tested and guaranteed Price £7.76 inc

Large selection of various speed geared motors from stock. Phone or write for details.

From stock at prices that defy competition

C/F Blowers Program Timers
 Microswitches Synch Motors
 write/phone your enquiries

NMS = NEW MANUF SURPLUS
 R&T = RECONDITIONED AND TESTED

SERVICE TRADING CO
 57 BRIDGMAN ROAD, CHISWICK, LONDON W4 5BB
 01-995 1560
 ACCOUNT CUSTOMERS MIN. ORDER £10

PROFESSIONAL SURVEILLANCE EQUIPMENT KITS

A RANGE OF HIGH QUALITY KITS AS SUPPLIED TO LEADING UK SECURITY COMPANIES. ALL KITS COME FULLY DOCUMENTED WITH CONCISE ASSEMBLY AND SETTING-UP DETAILS. FIBRE GLASS PCB AND ALL COMPONENTS. PLEASE ADD £1.50 TO COVER P&P. ALL UNITS AVAILABLE READY BUILT. DETAILS IN CATALOGUE

MTX Micro-miniature VHF transmitter. The smallest kit on the market measuring an incredible 17mm x 17mm including on-board mic. Super sensitive. Fully tuneable over FM band. 9V operation with range up to 1000m **£10.95**

VOX75 Voice-activated transmitter. Variable sensitivity trigger level switches transmitter on when sounds are detected. Stays on for time delay variable between 1-20 sec. Fully tuneable output covers all FM band. Very sensitive and low standby current through CMOS circuitry. 9V operation. Range up to 1000m. Measures 30mm x 40mm **£15.95**

VT800 High power version of the MTX with on-board PA stage providing 250mW of RF. Measures just 20mm x 40mm, power requirements 9-15V. Excellent sensitivity and stability. Fully tuneable over FM band. Ranges over 3000m can be expected **£12.95**

CTX900 Sub-carrier scrambled transmitter. Audio is double modulated providing very secure transmissions. Any unauthorised listener will not be able to demodulate signal without DSX900 Decoder unit. Fully tuneable output covering FM band. 9V operation. Range up to 1000m. Measures 30mm x 40mm **£18.95**

DSX 900 Decoder unit for CTX900. Connects to earphone output of receiver to descramble signal from CTX900 output to headphones. 9-12V operation. Measures 35mm x 50mm **£17.95**

TLX700 Micro size telephone transmitter. Connects onto line at any point and requires no batteries. Clearly transmits both sides of conversations on both incoming and outgoing calls. Undetectable by phone users. Fully tuneable output covering FM band. Range up to 1000. Measures just 20mm x 20mm **£9.95**

ATR2 Micro size telephone recording unit. Connects onto line at any point and connects into ANY normal cassette recorder having MIC and REM sockets. Requires no batteries. Switches recorder on silently when phone is used for incoming or outgoing calls. Switches off when phone replaced. Clearly records both sides of conversations. Undetectable by phone user. Measures 10mm x 35mm **£10.95**

XML900 RF Bug Detector/Locator. Wide band input circuitry detects presence of RF field and triggers flashing LED and piezo bleeper. Variable sensitivity enables source of transmission to be pinpointed to within 6 inches. Max sensitivity will detect MTX or similar transmitter at around 15-20 feet. 9V operation. Measures 55mm x 55mm **£21.95**

SUMA DESIGNS (Dept. PE), THE WORKSHOPS 95 MAIN ROAD, BAXTERLEY, N. ATHERSTONE, WARKS CV9 2LE. TEL 0827 71446

Send 28p stamp for new 1989 Catalogue including crystal transmitters, mains transmitters surveillance receivers etc. Phone orders on ACCESS, VISA, or AMEX accepted. TEL: 0827 714476

SIGNAL GENERATORS

Two new AF and RF Signal Generators.

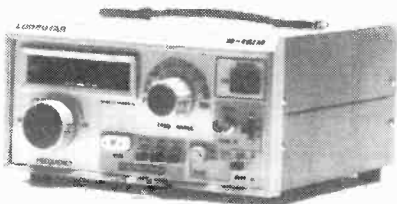

Audio Signal Generator

Low distortion AF signal generator and frequency counter.

Frequency Range: 10Hz to 1MHz (in 5 ranges)
Output imp: 600Ω unbalanced
Output atten: 0. - 20dB. - 40dB and fine adjust
Output distortion: <0.05% 500Hz to 50kHz
<0.5% 50Hz to 500kHz
Square wave range: 10Hz to 20kHz (0.5μs rise time)

56-02603 **£183.65**

RF Signal Generator

Signal generator and frequency counter covering 100kHz to 150MHz.

Frequency range: 100kHz-150MHz (upto 450MHz 3rd harmonic)
RF output: 100mV RMS (up to 35MHz)
Output atten: 0dB, - 20dB and fine adjust
Int. modulation: 1kHz
Frequency counter: 10Hz to 150MHz (in 2 ranges)

PRICES INCLUDE VAT AND CARRIAGE. 56-04162 **£183.65**

AVAILABLE EX-STOCK.

Cirkit



Cirkit Distribution Ltd.

Park Lane, Broxbourne, Herts EN10 7NQ.
Telephone (0992) 444111.



THREE SIMPLE CONSTRUCTION KITS

Especially aimed for the beginner. Have fun with your project even after you have built it and also learn a little from building it. These kits include high quality solder resist printed circuit boards, all electronic components (including speaker where used) and full construction instructions with circuit description.

- SK1 DOOR CHIME** - plays a tune when activated by a pushbutton **£3.90**
 - SK2 WHISTLE SWITCH** - switches a relay on and off in response to whistle command **£3.90**
 - SK3 SOUND GENERATOR** - produces FOUR different sounds, including police/ambulance/fire-engine siren and machine gun **£3.90**
- SPECIAL OFFERS FOR SCHOOL AND TRAINING CENTRES** - Contact Sales Office for discounts and samples.

SOLID STATE RELAY BARGAIN

- *ZERO VOLTAGE SWITCHING - No radio interference problems
- *2.5KV INPUT to OUTPUT ISOLATION - No risk of damage to your computer or driver circuits
- *4 KV TERMINALS TO HEAT-SINK ISOLATION - Simply bolt onto a heatsink
- *3V to 32V INPUT VOLTAGE easily interfaced to TTL or CMOS LOGIC
- *24V to 240V rms LOAD VOLTAGE - allowing mains loads to be switched
- *BUILT IN SNUBBER NETWORK - Enabling switching of inductive loads
- *10A MAXIMUM CURRENT - 4A with no heatsink fitted at 40°C



CD240/10 **£2.25**

ELECTRONIC GUARD DOG KIT



One of the best deterrents to a burglar is a guard dog and this new kit provides the barking without the bite! The kit when assembled can be connected to a doorbell, pressure mat or any other intruder detector and will produce a random series of threatening barks making the would-be intruder think you have a guard dog and try his luck elsewhere. The kit is supplied complete with high quality PCB, mains transformer, all components and instructions. The kit even includes a horn speaker which is essential to produce the loud sound required. The "dog" can be adjusted to produce barks ranging from a Terrier to an Aesalan and contains circuitry to produce a random series of barks giving a more realistic effect. Don't delay, fit one before you go on holiday and let our dog help you guard your home. **XK125 Complete kit of parts £24.00**

POWER-STROBE KIT

Designed to produce a high intensity light pulse at a variable frequency of 1 to 15Hz, this kit also includes circuitry to trigger the light from an external voltage source (eg a loudspeaker) via an opto isolator. Instructions are also supplied on modifying the unit for manual triggering, as a slave flash in photographic applications or as a warning beacon in security applications. The kit includes a high quality pcb, components, connectors, 5Ws strobe tube and full assembly instructions. Supply 240V ac. Size 75x50x45. **XK124 Stroboscope Kit £13.75**

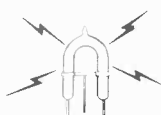

SUPER-SENSITIVE FM MICROBUG



Highly sensitive FM transmitter measuring only 45 x 25 x 15mm, including the built-in microphone. Frequency 88-100MHz enabling reception on a standard domestic FM radio. Range approximately 300m depending on terrain. Powered by 9V PP3 (7mA). Its small size and highly sensitive electret microphone makes it ideal for surveillance, baby alarm, etc.

INTRODUCTORY PRICE **£5.50**

MICROPROCESSOR TIMER KIT

Designed to control 4 outputs independently switching on and off at present times over a 7-day cycle. LED display of time and day, easily programmed via 20 way keyboard. Ideal for central heating control including different switching time for weekends. Battery back-up circuit. Includes box 18 time settings. **CT6000K £47.20**
XK114 Relay kit for CT6000 includes PCB connectors and one relay. Will accept up to 4 relays 3A/240V c/o contacts £24.30
701 115 Additional relays £1.80



DISCO LIGHTING KITS

DL1000K This value-for-money 4-way chaser features by-directional sequence and dimming. 1kW per channel **£19.25**
DLZ1000K - A lower cost uni-directional version of the above. Zero switching to reduce interference **£10.80**
DLA/1 Optional opto input allowing audio 'beat' light response **77p**
DL3000K - 3-channel sound to light kit features zero voltage switching, automatic level control and built-in microphone. 1kW per channel. **£15.60**

The **DL8000K** is a 3-way sequencer kit with built in opto-isolated sound to light input which comes complete with a pre-programmed EPROM containing EIGHTY - YES 80 different sequences including standard flashing and chase routines. The KIT includes full instructions and all components (even the PCB connectors) and requires only a box and a control knob to complete. Other features include manual sequence speed adjustment, zero voltage switching, LED mimic lamps and sound to light LED and a 300W output per channel. And the best thing about it is the price **ONLY £31.50.**

GIANT SOLAR CELLS

NOW IN STOCK these giant size solar panels 12 x 12in will deliver 12 volts 200mA in bright sunlight and 11.5 volts 60mA on a typical British summer day (dull and over-cast). **HUNDREDS OF USES** in the car or caravan, e.g. Charging NiCads, powering low voltage circuits where mains or battery supplies are inconvenient or coupled to a lead acid battery and a simple inverter you could build yourself a self contained mains supply for low power appliances. Stock No. 303 145. **£14.50** (plus £1.75 for p&p on total order)

TK ELECTRONICS 13 BOSTON RD. LONDON W7 3SJ Tel: 01 567 8910

ORDERING INFORMATION: ALL PRICES EXCLUDE VAT

FREE P&P on orders over £50 (UK only), otherwise add £1 + VAT. Overseas P&P: Europe £3.50. Elsewhere £10. Send cheque/PO/Barclaycard/Access No. with order. Giro No. 529314002. **LOCAL AUTHORITY AND EXPORT ORDERS WELCOME GOODS BY RETURN SUBJECT TO AVAILABILITY**

SEND 9" x 6" SAE & 50p FOR CATALOGUE OR CALL AT SHOP Mon-Fri 9-5 pm Saturday 10-4 pm



The problem with telephones is that you're not allowed to connect anything to the lines unless you've obtained official approval. A real shame, this, since there are all sorts of things one can invent that could make direct use of Buzby's wireful-world communications network. It's not allowed though!

Even though British Telecom now have special sockets into which other gear can be plugged, that equipment has to have the approval of Those in Charge. BT have

Fancy a quick dabble with the soldering iron? Your Ed's got a new series of quick-chippy circuits that you can put together in little more than the batting of an eyelid. They'll give you pleasure to build, and become useful little gadgets that you know you've always wanted, even if you didn't realise it! Here's this month's offering: a legal telephone monitor. We're sure it's for yoo-hoo!

Values of between 1 milli-Henry and 100 milli-Henries all produce results. The signal level obtained, though, is extremely small. We need to amplify it. One end of L1 is taken to a mid-voltage reference level, as set by R8 and R9, and the other taken via C1 and R1 to the inverting high-gain amplifier IC1A. C1 is made fairly small so that mains hum from nearby electrical wiring is not unduly picked up and amplified. The gain at IC1A is set by the ratio of R1 to R2, about 1000 times. The

REMOTE-A-BELL

BY JOHN BECKER

relinquished their authority on this, and it's OfTel who are now responsible. But, try as I might, it seems an impossibility to find out precisely what the situation is about getting approval for home telephone accessories that plug into the lines. However, adding together various statements made by different sources, it appears that even if a particular circuit is in theory suitable for approval, unless it's made by an approved manufacturer it may not qualify. "Too many possibilities for home constructors to get their assembly wrong", is the opinion generally offered. "We don't want poor unsuspecting telecom engineers knocked off their poles by a 250Vac overload if someone mistakes a mains socket for a 9V battery!" Point well taken.

INDICATING INDUCTORS

Still, all is not lost. There are other ways of doing things without direct connection. It's possible to detect the voltage changes in a telephone without plugging anything in. All it needs is an inductor close to the phone line and an amplifier. Surely there's no way that anyone's going to regard this as unoffical connection?

So what can we invent that's useful? Speech detection is really out of the question for a simple circuit since the

amount of amplification and consequent noise levels would be too high to accept. We can, though, remotely detect whether the phone bell is ringing, or if someone is dialling out. So let's take that as this month's quicky theme.

CIRCUITOUSLY EXTENDED

We'll build a circuit that will allow you to have an extension buzzer well away from the phone, out in the garden perhaps. It will also let you hear if someone is using the phone while you're off in another room somewhere. With all the recent fuss about Chat-lines, I can see that this might perhaps help cut down on phone bills! "I hear you dialling your friends again - make sure you put the money in the box ..."

Incredible as it may sound, you can detect whether the phone line is being pulsed simply by taking a single turn of its cable around a simple small inductor. The phone line swings up and down by about 50 volts when you dial out, or someone is ringing you. This change in voltage can induce a small current into the inductor. Looking at Fig.1, L1 represents the inductor and the single turn of cable around it.

The value of L1 has been found experimentally not to be at all critical.

output here is a very short pulse of a few millivolts, accompanied by diminishing harmonic peaks caused by the action of the inductor.

C2 isolates the dc output of IC1A so that only the pulse affects the next amplifier, IC1B. The amplification factor here too is around 1000 as set by R4 and R6. This is sufficient to raise the pulse to a respectable level, approaching the maximum allowed by the opamp characteristics. C4 just adds a little bit of damping to lower level noise signals. If on test the gain is found to be a bit high, and random noise still gets through, increase the value of R4, or decrease R6.

We now raise the pulse to full line level by using a comparator, IC1C. The comparator triggers from a low to high output state when incoming signals pass above the threshold level set by VR1, typically around 0.5V above half the battery level. Between them C4, D1, D2, C5 and R7 form a diode pump network. Pulses pass through C4 and D2 to charge up C5. When the charge on C5 exceeds the threshold level set by VR1, the comparator is triggered into a high output state. Once the pulses have ceased, R7 discharges C5, and IC1C reverts to its low output state.

DETECTIVITY

The output of IC1C is sufficiently powerful to allow a high impedance audible warning device to be connected directly to it. Alternatively, the output can be taken via the transistor TR1 to provide sufficient power for driving a small bell. The type of transistor used for TR1 is unimportant so long as it's an npn type capable of carrying the current through the speaker.

You can use any dc power supply of between about 5V and 15V. A 9V battery will do just fine. If you use a 5V supply, you could use the output of IC1C to send pulses to a computer so that you can do a bit of programmed detection work on the signal. I'm not going to give information about this here since I have a more complex computer-controlled dialling and cost

Fig.1. The Remote-A-Bell circuit diagram. Note that the pulse length can be extended by increasing C5 or R7

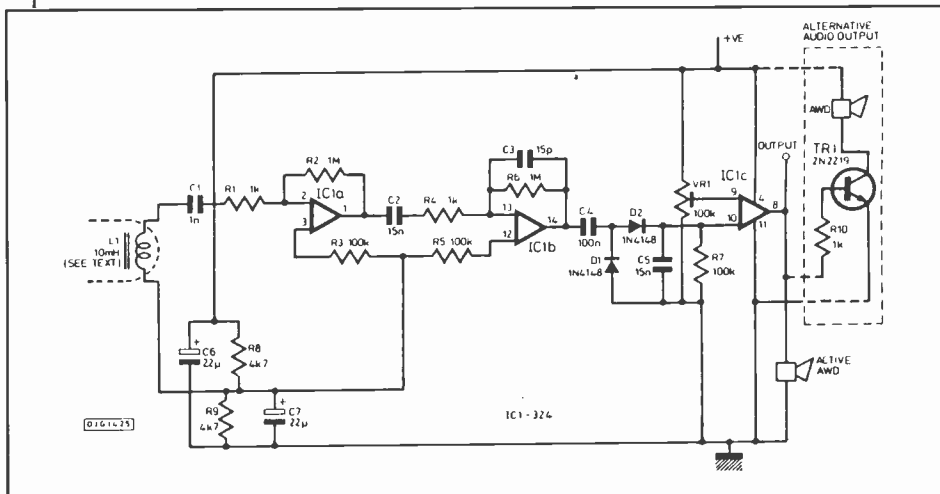

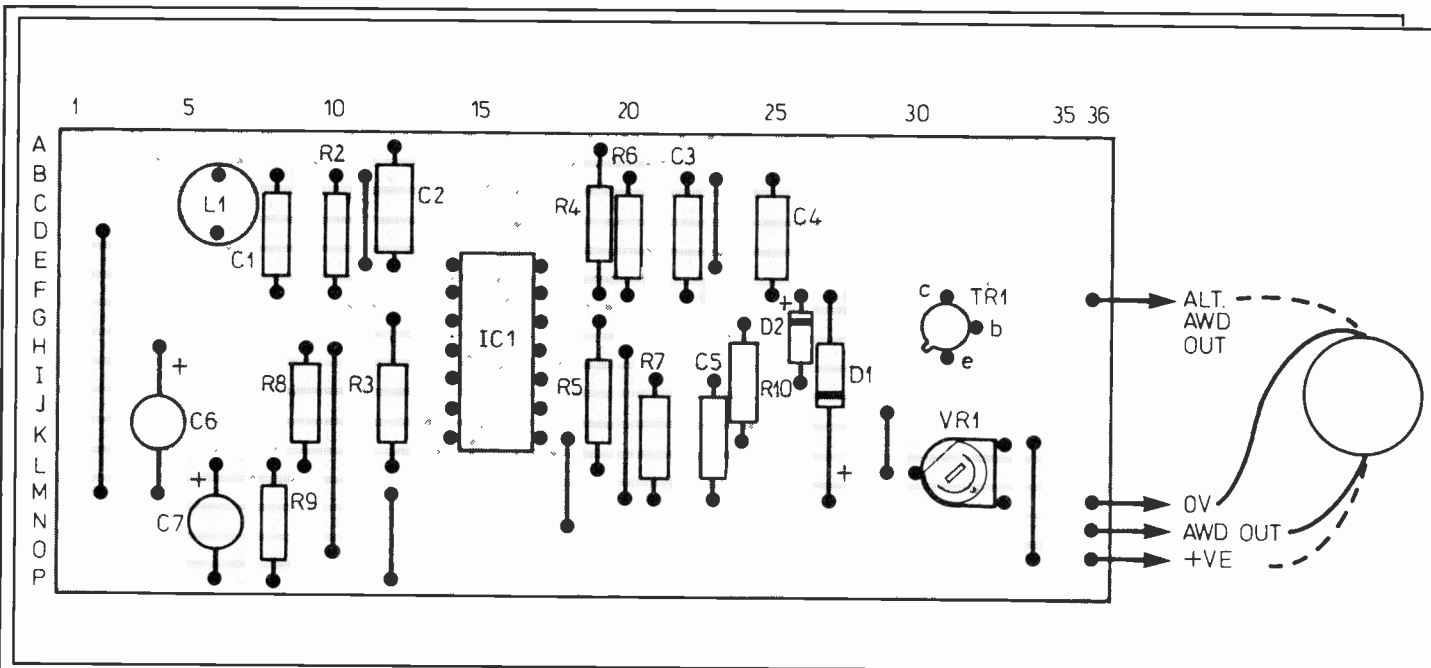

Fig.2. Suggested Veroboard layout

monitoring circuit in mind for some time in the future. But I'll give the hint that both serial and parallel computer ports can be used to detect changes in logic levels, and that Basic is fast enough for monitoring the phone pulses. This should give you something to think about!

There's hardly anything to the assembly of this circuit, and a small piece of Veroboard or similar is quite acceptable. A suggested layout is shown in Fig.2.

Just make sure that you check all your joins for satisfactory connections without shorts across the tracks. Remember to cut

all the track points where shown. Naturally, IC1, TR1, D1, D2 and the electrolytic capacitors must be inserted in the correct way round. There's no real setting up to be done - twiddle VR1 until the buzzer or bell remains silent until you dial out, or someone rings you.

One final point. The circuit, in its simplicity, can be subject to interference from spikes occurring on nearby mains wiring. Such things as fluorescent tubes, fridges and microwave ovens can create these spikes when they are turned on or off. Suppression techniques for such happenings

are beyond the scope of this simple project. The occasional "ping" on the extension bell, though, is unlikely to be mistaken for a true phone call or dial-out.

I hope to have another simple quicky for you next month.

PE

ED-LINES

SPEECH THERAPY

Nasa has introduced a computer controlled method whereby technicians can more accurately monitor the condition of each of the 31,000 heat resistant tiles on the Shuttle. Previously, one technician up a ladder would measure each of the tiles and shout down the results to a colleague on the floor - a system open to errors. Now a single technician speaks the number of each tile into a speech recognition unit and takes measurements with a laser tool, following instructions from a computer. The technique has cut down the total checking time from several months to just eleven days.

Ed.

Fig.4. Looping the phone cable. NB it may produce a stronger signal if the current flow direction is reversed - try it and see by turning over the cable loop.

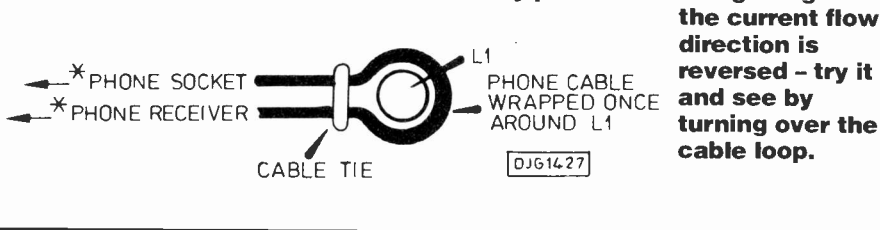
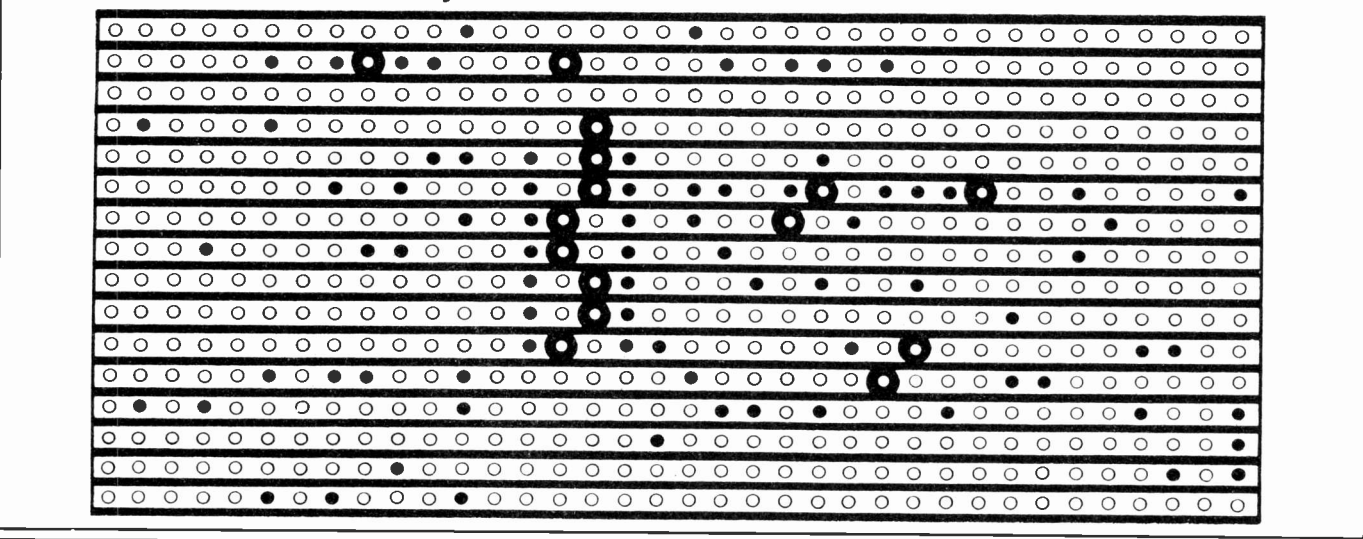

Fig.3. Track view of Veroboard layout.



STEVE CIARCIA'S FAMOUS BYTE PROJECTS NOW AVAILABLE AS TRIED AND TESTED KITS

ULTRASONIC RADAR

An easy to construct Ultrasonic Ranging system complete with transceiver module and Polaroid ultrasonic transducer.

System easily connects to any computer to measure distances from 18" to 35 ft with a resolution of 1.2".

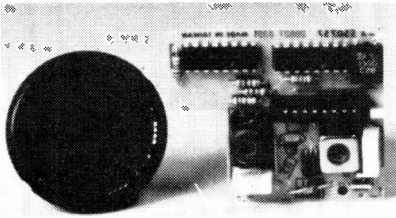

SERIAL EPROM PROGRAMMER

Use stand-alone or with computer/ Term. Programs standard or fast algorithm mode. menu selectable, no jumpers. Programs all 5V 27xxx Eeproms from 2716 to 27512.

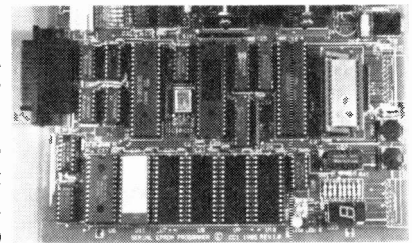

Intel Hex file Upload/Download.

SUPER IC TESTER

Tests over six hundred 7400-series TTL, L, S, H, C, HC, HCT, F, AS, and ALS devices, 4000-series CMOS and PALS. Identifies un-marked

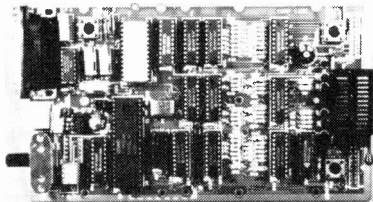

chips and bad IC pins. User definable test sequence and user expand-able ROM library. Operates stand-alone with LCD display, or with PC or terminal.

VIDEO DIGITISER

True "Frame Grabber", gets picture in 1 frame time. Bus independent digitiser. Serial output, transmits 300 bps to 57.6 kbps. Resolution is 256x244 64 grey

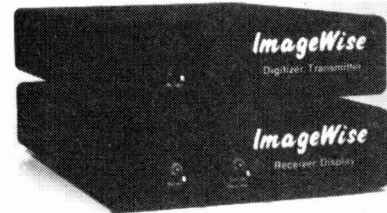

level. Accepts any B&W or colour composite video signal. Optional Rec/Display makes up a video telephone. Images can be stored and displayed on IBM PC. Comprehensive IBM image-processing software available.

MORE...

Other kits, and a wide range of fully-built computer boards, interfaces and other products also available.

FOR FULL PRODUCT CATALOGUE CALL J.B. DESIGNS 0285 658122
15 Market Place, Cirencester, Glos, GL7 2PB

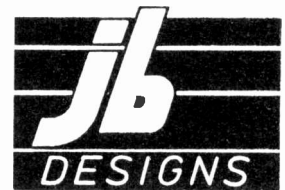

ANDOR ELECTRONICS

SPECIAL OFFER!

Ex Equipment I.C.'s EPROMS
2764 250nS 21vpp 150p
27128 250nS 12.5vpp 225p
27128 250nS 21vpp 225p
2716 125p
2732 150p
Eeprom Erased-Blanked Check
STATIC RAMS 400p
65256 32K 200nS
CAPACITORS
New Miniature Radial
10uF 50V 5p
47uF 16V 5p
1uF 35V Tant Axial 5p
2.2uF 63V Poly Axial 10p

I.C.'s 74HC

74HC00 22p
74HC02 22p
74HC04 22p
74HC10 22p
74HC14 50p
74HC20 22p
74HC27 22p
74HC30 22p
74HC32 22p
74HC42 40p
74HC74 39p
74HC75 39p
74HC123 44p
74HC125 50p
74HC138 50p
74HC151 50p
74HC157 62p
74HC161 62p
74HC163 65p
74HC175 50p
74HC193 58p
74HC195 54p
74HC240 75p
74HC242 77p
74HC244 77p
74HC257 50p
74HC366 62p
74HC390 77p
74HC393 77p
74HC4016 90p
74HC4040 62p
74HC4051 75p
74HC4066 90p

BUZZER

Min PCB 6V 75p
CRYSTALS 95p
32.768 KHz

I.C.'s 74HCT

74HCT00 32p
74HCT02 32p
74HCT04 30p
74HCT08 32p
74HCT10 32p
74HCT14 55p
74HCT20 32p
74HCT32 32p
74HCT73 70p
74HCT74 46p
74HCT75 52p
74HCT86 52p
74HCT93 80p
74HCT123 80p
74HCT138 60p
74HCT157 62p

I.C.'s 74LS

74LS00 20p
74LS02 20p
74LS04 20p
74LS10 20p
74LS13 30p
74LS14 35p
74LS20 20p
74LS27 20p
74LS30 20p
74LS32 20p
74LS42 40p
74LS47 39p
74LS74 39p
74LS75 39p
74LS123 44p
74LS125 50p
74LS138 50p
74LS151 50p
74LS161 62p
74LS163 65p
74LS175 50p
74LS193 58p
74LS195 54p
74LS240 75p
74LS242 77p
74LS244 77p
74LS257 50p
74LS366 62p
74LS390 77p
74LS393 77p
74LS4016 90p
74LS4040 62p
74LS4051 75p
74LS4066 90p

I.C.'s 74F

74F00 32p
74F02 32p
74F04 32p
74F08 32p
74F10 16 Way
74F20 32p
74F74 45p
74F86 45p
74F157 64p
74F161 140p
74F164 140p
74F175 90p
74F240 100p
74F244 100p
74F257 65p
74F373 100p

I.C. SOCKETS

Low Profile 6 Way 5p
8 Way 5p
14 Way 7p
16 Way 9p
18 Way 11p
20 Way 12p
24 Way 14p
28 Way 17p
40 Way 22p

L.E.D.'s

3mm & 5mm 10p
Red 10p
Green 12p
Yellow 14p

LED CLIPS

3mm & 5mm 5p

LED DISPLAYS

0.56" Dual Digit Red CA 199p
Red CC 199p
Green CA 220p
Green CC 199p

10 Segment Dtl Array

Bar array red 190p

CAPACITORS

Min Radial Lead 470pF 200V 5p
1nF 100V 7p
2.2nF 100V 7p
4.7nF 100V 7p
10nF 100V 7p
22nF 100V 7p
33nF 50V 7p
47nF 63V 10p
100nF 50V 10p
100nF 100V 10p

ELECTROLYTICS

2.2uF 63V 7p
4.7uF 16V 10p
10uF 16V 10p
22uF 25V 10p
47uF 16V 5p
100uF 16V 10p
65p 220uF 16V 15p
470uF 16V 25p

ZENER DIODES

BZX55 500mW 10p
BZX85 1.3W 17p
C3V3 C5V6 C12
C3V6 C5V2 C15
C4V7 C7V5 C24
C5V1 C9V1 C36

EPROMS

32K*8 12.5vpp
27C256 250nS 490p

RAMS

64K*1 Dynamic 220p
4164 150nS

BRIDGE RECTIFIERS

1.5A 300V 30p
1.5A 600V 32p
3A 200V 50p
3A 600V 60p
6A 200V 85p

DIODES

IN5401 3A 10p
IN5404 3A 12p
IN4148 3p
IN4004 1A 400V 5p

RESISTORS

METAL FILM 0.4W Min 7mm * 2.5mm
E12 Range 5%
1 Ohm - 1 Meg 2p
10 off 17p
100 off 150p

METAL FILM 0.6W

E24 Range 1% 4p
10 off 35p
100 off 300p

CARBON FILM 0.25W

10 Ohm - 1 Meg E12 Range 5% 1p
10 off 9p
100 off 70p
Prices for same value not mixed

RESISTOR PACK

CARBON FILM 0.25W 10 off each value
10 Ohm - 1 Meg
610 Resistors 490p

PLUGS & SOCKETS

Black Phono Plugs 12p
Black Phono Sockets 19p
1/4" Stereo Jack Socket 30p
1/4" Mono Jack Socket 27p

1/4" Stereo Jack Plug

35p
1/4" Mono Jack Plug 20p
3.5mm Stereo Jack 25p
25 Way D Cover 55p
25 Way D Type IDC Plug 190p
25 Way D Type IDC Socket 199p
25 Way D Type Solder Plug 70p
25 Way D Type Solder Socket 75p
34 Way IDC Card Edge 150p
34 Way IDC Centronics Plug 199p
36 Way Centronics Plug 155p

SOLDER 60/40

5 Metre 22 awg 95p
3 Metre 18 awg 95p
2 Metre 16 awg 95p
Black Suck on Feet 10mm x 10mm 4 off 25p
PCB 20mm Fuse Holder 12p

TRANSISTORS

BC182 12p
BC184 12p
BC547 10p
BC548 10p
BC549 10p
PNP
BC557 10p
BC558 10p
BC559 10p
OPTOCOUPLEDERS
6N138 220p
6N139 220p

NUTS & BOLTS

All Steel & Zinc Plated
CHEESE HEAD / COUNTERSUNK BOLTS
6 BA 1/2" 10 15p
100 120p
6 BA 3/4" 10 20p
100 160p
4 BA 1/2" 10 25p
100 200p
4 BA 1" 10 30p
100 240p

FULL NUTS

6 BA 10 12p
100 95p
4 BA 10 15p
100 120p

ODDS & ENDS

Sleeved Grammet 1 5p or 5 20p
Resistor 0.4W 27 ohm CF 5% 0.5p
0.4W 360 ohm MO 5% 1p
0.4W 210 K MO 1% 2p
Resistor 1.0W 47 ohm MO 2% 2p
1.0W 2.7 K MO 2% 2p
DIL Network 15*3.3K 20p

STOCK ITEMS BY RETURN.

ADD 75p P&P

ALL PRICES INCLUSIVE.

SEND CHEQUE or P.O. to...

ANDOR ELECTRONICS,
DEPT EE, VICTORIA HOUSE,
PAXTON STREET, HANLEY,
STOKE-ON-TRENT, ST1 3SD
TEL: 0782 283642.

MAJOR AND MINOR

Dear Ed,

After reading part one of the Dual Beam Oscilloscope, I decided that, like you lots of years ago, I would make it my first major project. But when looking through the components list it said 'a suitable transformer is available from Barrie Electronics, type Y1' but they don't have a Y1 transformer in their advert. Also, what is a Phonosonics PCB, and what do you mean when something says 'R55 3M3'?

Thank you very much, but before I go, I think PE is great for all ages, and even my brother (8 yrs) has a read sometimes (even though he doesn't understand it).

D.L. Breeze, Bournemouth.

You are obviously someone destined to make electronics your career if you keep up your enthusiasm (and perhaps your brother will too).

Barrie Electronics DO have stocks of the Y1 transformer. Remember that many advertisers have far more items to sell than they have space to publicise in an advert.

A Phonosonics pcb is a printed circuit board sold by Phonosonics, who are one of our advertisers. Where a company name is mentioned in a constructional parts list the company will usually carry an advert in the same issue, so look at their advert for their address, then write for more details of their products, enclosing a stamped addressed envelope for their reply.

A number like R55 is the number given to a component in a circuit or pcb diagram. Each component will have a different number prefixed by, for example, R for resistor, C for capacitor, D for diode etc. The 3M3 means that the value of R55 is 3M3, or in other words has a resistance of 3.3 Megohms, which is the same as saying 3,300,000 ohms.

Best wishes to you and your brother.

Ed.

STAR DRIVE

Dear John

I am a retired electronics engineer and subscribe to PE because I want to stay in touch, mainly through Marketplace, Industry Notebook, Leading Edge, Editorial and Spacewatch.

I write in response to Mr Trice's letter (PE Sept 88) about Astro Electronics and your reply and appeal to readers. I have misgivings about Mr Trice's idea of using a stepper motor to drive a telescope. They are inherently very low torque devices and in view of telescope mass and power losses in the

If you have any comments, criticisms or suggestions, write and let us know. We are interested in what you think and say, especially regarding our new style and your views on our role for the 1990s.

reduction gear wonder if their torque would be sufficient. Also, the fact that the speed must be variable might lead to a complicated and expensive clock control.

A small universal motor, such as a washing machine spinner, might be more appropriate. They have a high torque and are easily controlled by a dedicated chip, like one of the TLE310x series from Seimens, with a tachogenerator in the control loop. This would be less complicated and cheaper. However, before starting on a project like this I need a few questions answered -

What should be the mean tracking speed taking into account Earth's movement round the Sun? Is it true that dedicated amateur astronomers have instruments up to six inches? What speed variation is admissible when taking photographs? How does one calculate the exposure values?

D.Balet, Co Kerry, Eire

I share your misgivings about stepper motors and believe that

synchronous motors will achieve more satisfactory results under adequate control.

The Siderial Clock article in PE Feb 89 gives figures for calculating sidereal time which, compared to solar time, gains approximately 3 minutes 56 secs per solar day. Patrick Moore's opinion is that it is pointless to spend money on any refracting telescope with an aperture of less than three inches or a reflector with a main mirror less than six inches diameter. The subject of light intensity and camera exposure values is too complex for a published reply so I refer you to the Astrophotography article in Astronomy Now Apr-Jun 1987, and to the book Astro Physical Quantities by Clayborn Allan (available through a library). As a rough guide, with an f1.8 28mm lens, 30 seconds exposure on 1000 ISO film will probably produce acceptable results without apparent star trailing.

Ed

MICROWAVES

Dear Ed,

To answer Christopher Law's letter in PE Oct 88, microwave ovens do not emit particles that could be detected by a Geiger counter, rather, they emit electromagnetic waves in the frequency range of around 2.5 GHz. They can readily be detected by a passive receiver similar in essence to a humble crystal set.

I recall that some years ago I saw an article describing such a unit. It consisted of a di-pole aerial some 42mm long and formed as part of a

pcb track with an ultra-high frequency diode across a gap in the middle of the aerial. Two inductors were formed as part of the pcb track, coming from each side of the diode, with a small value capacitor across the two inductor ends. A 250µA meter, in series with a limiting resistor, was then connected across the capacitor. It needed no power supply since any microwave leakage would generate sufficient current to drive the meter directly.

C.P. Finn, Beverley

Thanks, I assume you mean something like this

Ed.

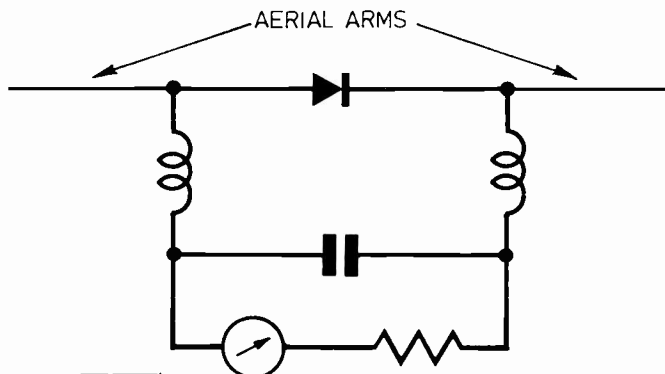

ELECTRONIC SMOG

Dear Ed,

Barry Fox's article dealing with 'electronic smog' (PE Sept 88) is timely although the problem is not new. One might also include high voltage ac railway electrification as another offender.

I did not, however, understand the comment that a motor or welder has zero resistance at the moment of switch-on. Surely resistance is a physical property of the conductors and is always present? The in-rush current depends upon the source impedance of the supply and the resistance and reactance of the motor. The latter is complex but is low at standstill, hence the high current, and increases as the motor speed rises. In the case of welders I think the real problem arises from the electromagnetic energy associated with the welding arc.

Finally, let us not forget the effect of mains spikes on components leading to breakdown.

M.W.Burnby, Wirksworth, Derby

Mr Burnby is right of course. I was using shorthand. At the moment of switch-on there is an almost complete short circuit across the supply because resistance is almost zilch - then reactance and inductance take over.

I appreciate helpful comments like this - it keeps journalists like me on our toes.

Barry Fox

SANTA COPS IT

Dear Ed,

I must thank you for the relief you have given to the thousands of electronics enthusiasts who might become professionals. I believe that the most wonderful Christmas present for the people I speak for is your diy oscilloscope - it's a dream come true. We were like trained policemen who were only given pen and paper to take complaints from the public but who were never allowed to go out and investigate.

With your scope we will now be able to build circuits and investigate them, finding out what really goes on inside. You have broken down a barrier on the road towards professionalism. Bless you.

S.Oleghe, Wandsworth.

This is the sort of reaction that I had hoped to provoke - creating greater enthusiasm among less experienced readers by showing them how to gain visual knowledge of circuit responses, but without too much expense.

Ed

Power Supplies

TS3022S

DUAL 0-30V 0-2A PRICE: £299 + VAT

TS1541S

0-15V 0-4A PRICE: £165 + VAT

TS3021S

0-30V 0-2A PRICE: £159 + VAT

FEATURES:-

- Dual 3.5 digit LCD display of V and I (TS3022S four).
- Constant V or constant I modes.
- Protected output.
- Remote sensing.
- Line and load regulation <math>< 0.01\%</math>
- Ripple and noise <math>< 1\text{mV}</math>
- Low radiated and conducted interference.

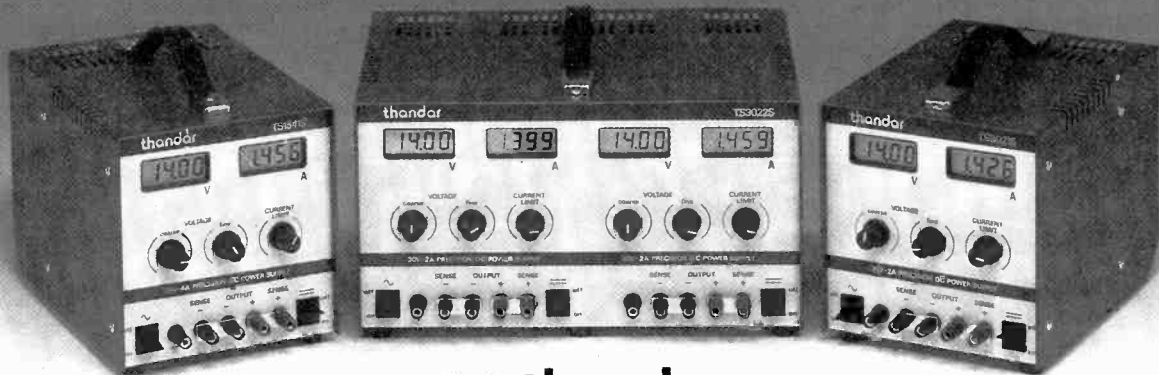

thandar
ELECTRONICS LIMITED

For further details of these and other products in the Thandar range, please send for a catalogue.

Thandar Electronics Limited, 2 Glebe Road, Huntingdon, Cambridgeshire. PE18 7DX. Telephone (0480) 412451 Fax (0480) 411463 Telex 32250 Test G.

HART

HART ELECTRONICS are specialist producers of kits for designs by JOHN LINSLEY-HOOD. All kits are APPROVED by the designer.

LINSLEY-HOOD CASSETTE RECORDER CIRCUITS

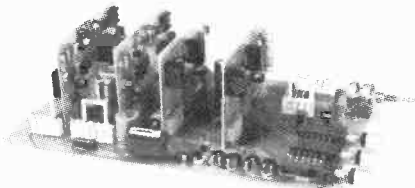

Complete record and replay circuits for very high quality low noise stereo cassette recorder. Circuits are optimised for our HS16 Super Quality Sendust Alloy Head. Switched bias and equalisation to cater for chrome and ferric tapes. Very easy to assemble on plug-in PCBs. Complete with full instructions.

Complete Stereo Record/Play Kit £33.70
VU Meters to suit £2.30 each
Reprints of original Articles 75p no VAT
860X Stereo Mic Amplifier £8.70

LINSLEY HOOD 300 SERIES AMPLIFIER KITS

Superb integrated amplifier kits derived from John Linsley-Hood's articles in 'Hi-Fi News'. Ultra easy assembly and set-up with sound quality to please the most discerning listener. Ideal basis for any domestic sound system if quality matters to you. Buy the kit complete and save pounds off the individual component price.

K300-35 35 Watt Discount price for Complete Kit . £98.79
K300-45 45 Watt Discount price for Complete Kit £102.36
RLH4&5 Reprints of Original Articles from 'Hi-Fi News' £1.05 no VAT

LINSLEY-HOOD SUPER HIGH QUALITY AM/FM TUNER SYSTEM.



Our very latest kit for the discerning enthusiast of quality sound and an exotic feast for lovers of designs by John Linsley-Hood. A combination of his ultra high quality FM tuner and stereo decoder described in "ELECTRONICS TODAY INTERNATIONAL" and the Synchronyne AM receiver described in "Wireless World". The complete unit is cased to match our 300 Series amplifiers. Novel circuit features in the FM section to include ready built pre-aligned front-end phase locked loop demodulator with a response down to DC and advanced sample and hold stereo decoder together make a tuner which sounds better than the best of the high-priced exotica but, thanks to HART engineering, remains easy to build. The Synchronyne section with its selectable bandwidth provides the best possible results from Long and Medium wave channels so necessary in these days of split programming. If you want the very best in real HiFi listening then this is the tuner for you. Since all components are selected by the designer to give the very best sound this tuner is not cheap, but in terms of it's sound it is incredible value for money. To cater for all needs four versions are available with variations up to the top of the range full AM/FM model, with any unit being upgradeable at any time. Send for our fully illustrated details.

STUART TAPE RECORDER CIRCUITS

Complete stereo record, replay and bias system for reel-to-reel recorders. These circuits will give studio quality with a good tape deck. Separate sections for record and replay give optimum performance and allow a third head monitoring system to be used where the deck has this fitted. Standard 250mV input and output levels. These circuits are ideal for bringing that old valve tape recorder back to life.

K900W Stereo Kit with Wound Coils and Twin Meter Drive £65.67
RJS1 Reprints of Original Articles £1.30 no VAT

HIGH QUALITY REPLACEMENT CASSETTE HEADS



Do your tapes lack treble? A worn head could be the problem. Fitting one of our replacement heads could restore performance to better than new! Standard mountings make fitting easy and our TC1 Test Cassette helps you set the azimuth spot-on. We are the actual importers which means you get the benefit of lower prices for prime parts. Compare us with other suppliers and see! The following is a list of our most popular heads, all are suitable for use on Dolby machines and are ex-stock.

HC20 Permalloy Stereo Head. This is the standard head fitted as original equipment on most decks £7.66
HS16 Sendust Alloy Super Head. The best head we can find. Longer life than Permalloy, higher output than Ferrite, fantastic frequency response £14.86
HQ551 4-Track Head for auto-reverse or quadrophonic use. Full specification record and playback head £14.60
HX100 Stereo Permalloy R/P head. Special Offer £2.49
MA481 2/2 Language Lab R/P head £13.35
SM166 2/2 Erase Head. Standard mounting, AC type £8.85
SM150 2/2 Erase Head. DC Type £3.60
HQ751E 4/4 Erase Head for Portastudio etc. £46.80
Full specifications of these and other special purpose heads in our lists.

HART TRIPLE-PURPOSE TEST CASSETTE TC1

One inexpensive test cassette enables you to set up VU level, head azimuth and tape speed. Invaluable when fitting new heads. Only £4.66 plus VAT and 50p postage.

Tape Head De-magnetiser. Handy size mains operated unit prevents build up of residual head magnetisation causing noise on playback £4.85
Curved Pole Type for inaccessible heads £4.85

Send for your free copy of our LISTS. Overseas please send 2 IRCs to cover surface Post or 5 IRCs for Airmail.

Please add part cost of post, packing and insurance as follows:

INLAND
Orders up to £10 - 50p
Orders £10 to £49 - £1
Orders over £50 - £1.50

OVERSEAS
Please send sufficient to cover Surface or Air Post as required

Personal callers are always very welcome but please note that we are closed all day Saturday

24hr SALES LINE
(0691) 652894

ALL PRICES EXCLUDE VAT
UNLESS STATED

HART
HART ELECTRONIC KITS LTD
4 PENYLAN MILL
OSWESTRY, SHROPSHIRE
SY10 9AF

Barry Fox, in *Leading Edge* of PE Jan 89, reported on the imminent arrival of the second generation of cordless telephones, the so-called CT2 generation. Keith Clarke of British Telecom Research Laboratories obliquely referred to CT2 in part one of *Home Automation* last month. "The expectation is", he said, "that in the future the customer will have a stylised personal communicator which will operate to any of a large number of receivers and transmitters". The concept of which he spoke, in fact encompasses personalised transceivers not only of the CT2 genus, but also those of CT3 and beyond. CT2, though, has now been officially announced and, by the time this report is published, should be at the mass production stage. It will shortly be available

in the BBC tv series "*Bread*", and the cellular phone variety. As a quick recap, "*Bread*" phones have a low-power two-way radio in the handset and, using analogue techniques, communicate with a mains powered base station plugged into the user's own telephone line. The range varies from around 50 metres indoors, to at best 1km outside. Cellular phones also use a radio link, but communicate with commercial base stations at which computers handle the call routing to mobile targets throughout most of Britain.

This first generation technology, CT1, is subject to interference and suffers from low speech quality which gradually falls off even further as the user starts to move away from the base station. CT1 also has an inherent lack of security, through operating

on a fixed frequency with only eight channels available, and being open to eavesdropping by unauthorised listeners.

CT2 is being implemented under the general name of telepoint and offers an inherently more secure mode of operation, using digitally coded techniques. The telepoint concept consists of a network of public base stations linked into the public switched telephone network. Subscribers will be able to access the network using personal pocket sized cordless phone handsets. The intention is to liberally scatter the base stations at strategic places around the country. Locations may be as diverse as railway stations, shopping centres, restaurants and service stations. It is also possible to purchase one's own station for domestic or office installation.

TELEPOINTING THE FORUM WAY

By Michael Strassen

to domestic consumers, and to all potential operators of the telepoint networks which will be installed in the UK during 1989. A powerful advantage of CT2 technology is that base stations can be installed quickly and cheaply in virtually any location, in public places, at the office or at home.

BACKGROUND

Personal communicators of the cordless telephone variety have been around for some time, falling into two basic categories: those of the conventional type immortalised

The British are scoring points with CT2, a lighter, simpler access-only version of the poserphone. There are five to win in the PE competition, too.

ROVING ACCESS

Although the system is intended for roving use, it is not a mobile phone as such. The user must remain within the locality of a base station, the public versions of which do not allow handsets to receive incoming calls. Besides which, unlike the cellular phone network, there is no central computing system which can search out the locality of a given receiver. However, because it is basically only an outgoing system, the circuit design is much simpler, and the handsets can be far lighter.

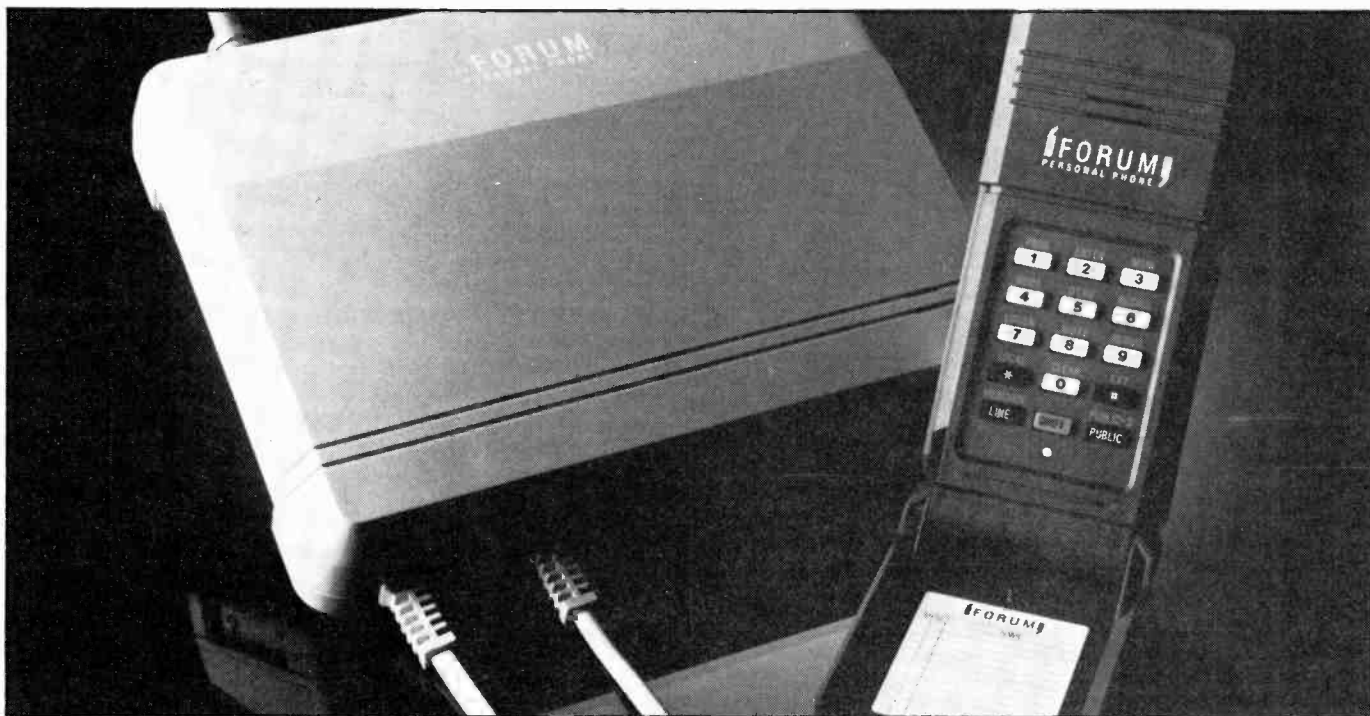



laboratory set up by Sir Clive Sinclair (whose entrepreneurial endeavours are much admired by PE).

FORUM HANDSETS

Known as the Forum, Shaye's handset weighs just 130 grams, around the same as popular calculators, and contains an integral aerial. It communicates via the telepoint network and complies with the common air interface (CAI) standard for CT2 systems. This standard defines the radio interface between equipment produced by different manufacturers and allows interworking of products.

Operating in the 864 to 868 MHz spectrum, the Forum phone offers excellent speech quality with no degradation as the caller moves toward the speech range extremity. Interference is further limited and security improved by the fact that the phone is frequency-agile and selects the best available channel out of a range of 40 each time a call is made.

The handset fits easily into the pocket and offers up to 50 hours of continuous speech from a replaceable long-life lithium cell. Alternatively, the user may opt for a rechargeable nickel-cadmium battery used in conjunction with the Shaye nicad battery recharger.

To make a call once you are within range of a telepoint station, switch on the handset by opening the flap which conceals the keypad when the phone is not in operation. Select an appropriate telepoint network (customers can subscribe to more than one network) which will ask for your PIN. Enter the number, then key in the telephone numbers, make the call, and on completion, close the flap.

To dial into the national and international telephone network the user simply stands within range of a telepoint, typically around 200 yards, switches on the handset, enters a personal identification number (PIN) and keys in the appropriate telephone number. The telepoint will check that each handset's unique code number corresponds to the user's PIN, so ensuring that no unauthorised use can be made of the system and that calls are correctly allocated for subsequent billing. As an additional safeguard, subscribers will receive fully itemised bills - similar to the use of credit cards in this respect. Calls will be charged at the normal telephone rates. Although there will be additional subscription charges, the tariffs will be considerably lower than those for cellular services.

The technology is totally British, and the UK is the first entrant to this communications field. There are four licence holders in the scheme, consisting of BT/STC, Mercury/Shaye, Ferranti, and a group including Philips, Barclays and Shell. Shaye Communications is the company who have designed and developed the first of the CT2 handsets and base stations for the telepoint network. Shaye grew out of a

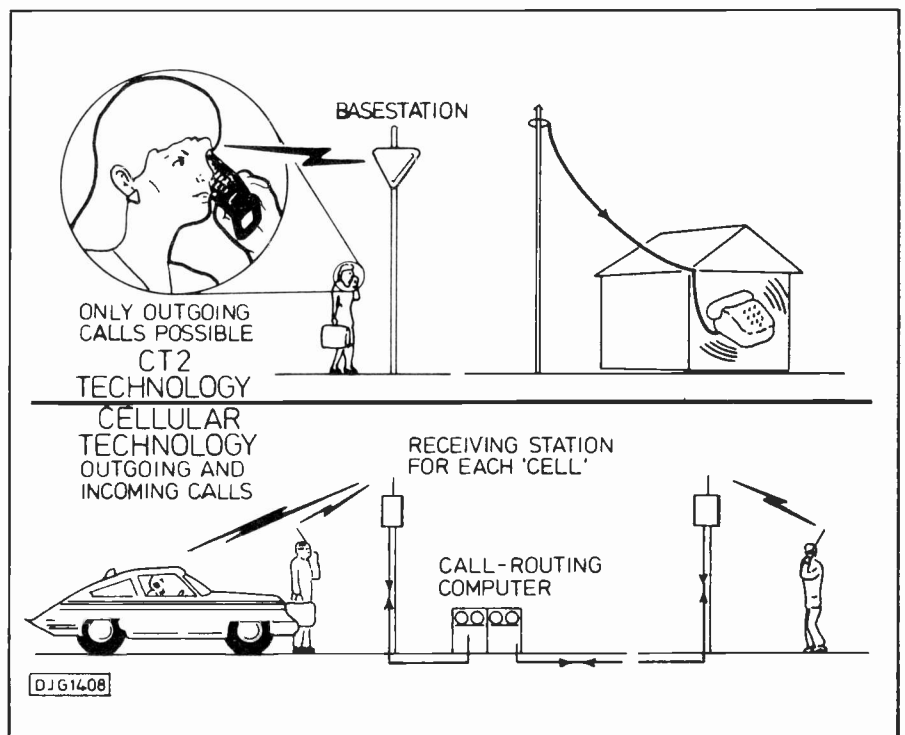



If you have a Forum personal base unit plugged permanently into a standard telecom wall socket at home or the office, calls can be made or received in exactly the

same way as existing cordless phones operate. In the office the personal base unit can be connected to either a direct line or pabx exchange line. For outgoing calls the

handset is operated in the same way as if you were using a public telepoint station. With the Forum you can also receive incoming calls via the personal base station. If the handset rings, indicating an incoming call, pick up the handset, open the flap and respond as normal.

STANDARD FORUM FEATURES

- Pushbutton digit dialling.
- Memory storage of 12 x 22 digit numbers.
- Last number redial.
- User selection of loop disconnect of dtmf signalling.
- User selection of telephone service provider (BT or Mercury).
- User selection of telepoint service provider.
- Call transfer.
- Intercom through suitably equipped base unit.
- Mute.
- Memory retention during battery change.
- Inbuilt protection against recharging a non-rechargeable battery.
- Reverse battery polarity protection.
- Low battery indicator.

INFORMATION

The Forum Personal Phone and the Forum domestic base unit will retail at £150 each, plus vat. Both will be available through multiple retailers and other outlets. For further information please contact Shaye Communications, Capital House, 48-52 Andover Road, Winchester, Hampshire SO23 7BH. Tel: 0962 55925, or Jonathan Simnett/Isabel Robertson, A Plus Public Relations on 0753 686655.

FORUM FOR ALL

Shaye's chief executive, Bill Jeffrey, comments. "For the first time the consumer will be able to have a single telephone that is personal to them, one which they will be able to take with them at all times and use in the home, in the office and when they are out and about."

"The Forum personal phone is". Bill Jeffrey continues, "the smallest, lightest, and most truly portable cordless telephone developed to date, one that will change the face of personal communication in the next decade."

PE

FORUM HANDSET FACTS

Dimensions	143.5 x 61 x 2mm maximum
Weight incl lithium battery	130gms
Construction	Injection moulded abs
Controls	15-key silicone rubber keypad Flap operated on/off switch Flap release button
Transducers	Moving coil earpiece Electret microphone
Range	Up to 200 metres
Power source	Replaceable lithium cell or rechargeable battery pack
Supply voltage	3.6V nominal
Battery life	Dependent on use pattern, typically 6 months in domestic use using lithium cell, and 6 weeks in business environment

WIN YOUR OWN FORUM

Now you've read about the Forum, enter the PE competition and stand the chance to win one of five handsets. You could be one of the first owners of this hi-tech personal communicator. See page 61.

MAKING ELECTRONICS C.A.D. AFFORDABLE

PCB CAB, FOR THE PC/XT/AT – EASY-PC AND TINY-PC

- Are you still using tapes and a light box?
- Have you been putting off buying PCB CAB software?
- Have you access to an IBM PC/XT/AT or clone inc Amstrad 1640 & 1512
- Would you like to be able to produce PCB layouts up to 17" square?
- With up to 8 track layers and 2 silk screen layers?
- Plus drill template and solder resist?
- With up to eight different track widths anywhere in the range .002 to .531"
- With up to 16 different pad sizes from the same range?
- With pad shapes including round, oval, square, with or without hole and edge connector fingers?
- With up to 1500 IC's per board, from up to 100 different outlines?
- With auto repeat on tracks or other features – ideal for memory planes?
- That can be used for surface mount components?
- With the ability to locate components and pads on grid or to .002" resolution?
- With an optional auto via facility for multilayer boards?
- With the ability to create and save your own symbols?
- That can be used with either cursor keys or mouse?
- That is as good at circuit diagrams as it is a PCB's?
- That outputs to Dot Matrix Printer, or, with extra drivers can drive a pen plotter or photoplotter.
- Where you can learn how to use it in around an hour?

TINY-PC £95.00 + VAT EASY-PC £275.00 + VAT

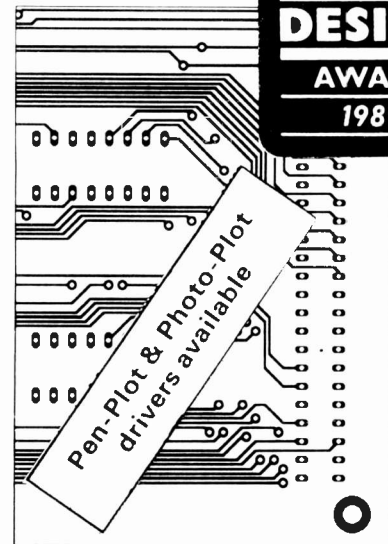

SMITH CHART PROGRAM – Z-MATCH

For IBM, PC/XT/AT and clones inc. Amstrad 1512 and 1640 and BBC B, B+ and Master.

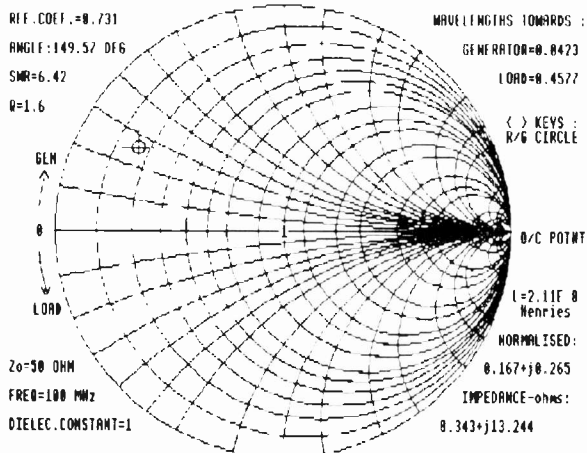

Z-MATCH – Takes the drudgery out of R.F. matching problems. Includes many more features than the standard Smith Chart. Provides solutions to problems such as TRANSMISSION LINE MATCHING for AERIALS and RF AMPLIFIERS with TRANSMISSION LINE TRANSFORMER and STUB MATCHING methods using COAXIAL LINES MICROSTRIP, STRIPLINE and WAVEGUIDES. the program takes account of TRANSMISSION LINE LOSS. DIELECTRIC CONSTANT, VELOCITY FACTOR and FREQUENCY. Z-MATCH is supplied with a COMPREHENSIVE USER MANUAL which contains a range of WORKED EXAMPLES

£130 for PC/XT/AT etc £65.00 for BBC B, B+ and Master

CIRCUIT ANALYSIS BY COMPUTER – ANALYSER II

For IBM, PC/XT/AT and clones inc. Amstrad 1512, 1640, R.M. NIMBUS, and BBC B, B+, and Master.

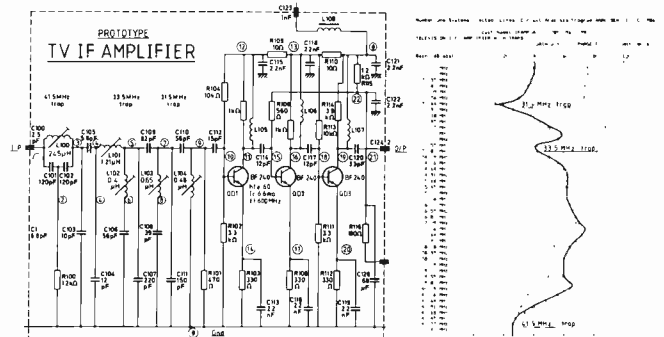

"ANALYSER II" – Analyses complex circuits for GAIN, PHASE, INPUT IMPEDANCE, OUTPUT IMPEDANCE and GROUP DELAY over a very wide frequency range.

Ideal for the analysis of ACTIVE and PASSIVE FILTER CIRCUITS, AUDIO AMPLIFIERS, LOUDSPEAKER CROSS-OVER NETWORKS, WIDE-BAND AMPLIFIERS, TUNED R.F. AMPLIFIERS, AERIAL MATCHING NETWORKS, TV I.F. and CHROMA FILTER CIRCUITS, LINEAR INTEGRATED CIRCUITS etc. STABILITY CRITERIA AND OSCILLATOR CIRCUITS can be evaluated by "breaking the loop". Can save days breadboarding and thousands of pounds worth of equipment.

£195 for PC/XT/AT etc. £130 for BBC B, B+ and Master

All prices Ex-VAT
WRITE OR PHONE FOR FULL DETAILS:- REF PE

Number One Systems Ltd



Harding Way, St Ives, Huntingdon Cambs, PE17 4WR
Tel: St Ives (0480) 61778
We provide full after-sales support with free telephone 'hotline help' service.
Software updates are free within 6 months of purchase date.

PRACTICAL ELECTRONICS CLASSIFIED

Reach thousands of serious electronic and computer enthusiasts. Advertise in PE Classified pages: Rates 20p per word or £8.50 per single column cm (plus VAT). All classified advertisements must be pre-paid. Send your copy with the remittance (payable to Intra Press or payment by Visa or Access accepted) to: **Practical Electronics, Intra House, 193 Uxbridge Road, London W12 9RA. Tel: 01-743 8888. Fax: 01-743-3062**
LET PE WORK FOR YOU!

EDUCATION

FULL-TIME TRAINING COURSES

2 YEAR
BTEC NATIONAL DIPLOMA
 Electronics and Communications Engineering
 (TV, Computers, Programming, IT)

1 YEAR
BTEC NATIONAL CERTIFICATE
 1. Electronic Equipment Servicing
 (TV, Video, CCTV)
 2. Computing Technology
 (Microprocessors, DataComms, Interfacing)
 3. Information Technology
 (Telecomms, Satellite TV, CD, Networks)
 4. Software Engineering
 (Assembler, BASIC, PASCAL, CAD/CAM)

COURSES COMMENCE
 Monday 24th April / 18th Sept. 1989

LONDON ELECTRONICS COLLEGE

Dep: AA, 20 Penywern Road,
 London SW5 9SU. Tel: 01-373 8721

Start training now for the following courses.

- Telecomms Tech C&G 271
- Radio Amateur Licence C&G
- Microprocessor
- Introduction to Television

Send for our brochure - without obligation or telephone us on 06267 79398 (Ref: PE1/89)
 Name.....

Radio & Telecommunications
 Correspondence School,
 12 Moor View Drive, Teignmouth,
 Devon TQ14 9UN

RETAILERS

BATH

L.F. HANNEY

77 Lower Bristol Road, Bath,
 Avon.
 Tel: 0225-24811

Your electronics component specialist for
AVON, WILTS. & SOMERSET
 Open every day, except on Thursday

BURTON - ON-TRENT

MAGENTA ELECTRONICS Ltd

Shop now open - callers
 welcome!

135 Hunter Street,
 Burton-on Trent,
 Staffs. DE14 2ST

EDINBURGH

OMNI ELECTRONICS

stock a wide range of
 electronic components at
 174 Dalkeith Road
 Edinburgh EH16 5DX
 Tel: 031 667 2611

Open Mon-Fri 9am-6pm
 Sat. 9am-5am

Send 2x19 stamps for NEW CATALOGUE!

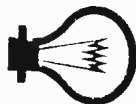

Help PE Readers!

Put projects into practice.
 Project your component image
 here!

Phone PE on 01-743-8888

LONDON

TECHNOMATIC Ltd.

See our display advertisement
 in this magazine!

SOUTHSEA

ELECTRONIC COMPONENTS

EVERYTHING FOR YOUR NEXT PROJECT
 THE BIGGEST DISPLAY IN THE SOUTH
 IS AT

FRASER ELECTRONICS

42 ELM GROVE ★ SOUTHSEA ★ HANTS
 Telephone: 0705-815584

Barclaycard

Access

MANCHESTER

DEANSGATE ELECTRONICS

We stock a large range of electronic
 components, test equipment, telephone
 accessories, computer accessories,
 microphones, speakers, disc lighting, mixers,
 meters, stylus, so call in and have a look
 around.

263 Deansgate, Manchester
 Telephone: 061-834 1185

STOKE-ON-TRENT

ANDOR ELECTRONICS

11 Victoria House,
 Paxton Street,
 Hanley,
 Stoke-on-Trent, ST1 3SD
 Tel: 0782 283642

SURREY

PLS

16 Central Road
 Worcester Park
 Surrey KT4 8HZ
 Tel: 01-330 6540

Programmable device specialists.
 (PAL's PROM's, PLD's etc). Many other
 components in stock

Resistors 1/4 W 5% carbon (E12) 1p metal film 1% (E24)3p
 Resistor Pack 85 different E12 values + zero ohm link total contents
 1000 resistors £8.95
 LEDs red/green 3/5mm 6p each. Yellow 11p
 Cable ties 75mm 1p each £5.95/1,000 £49.50 per 10,000
 Stepping motor 4 phase 12v 7.5 step 50 ohms £8.95
 SAA1027 stepping motor driver chip £3.95
 Miniature FM transmitter kit 100-108 Mhz high quality sound ideal for
 cordless microphones or guitars etc £7.48
Special offers
 Computer Grade Capacitors with screw terminals
 3800uf 60v £4.00 4700uf 63v £1.50
 38000uf 20v £1.95 87000uf 10v £1.50
 7 segment Common anode led display 12mm £0.45
 LM2931A.T5.0 Low drop out 5V regulator T0220 package £0.65
 BS250 P channel MOSFET £0.45
 BC559 transistor T092 PNP £3.95 per 100
 74LS05 hex inverter £(0.00 per 100
 AM27502DC memory £1.50
 Stereo L.W/MW/FM Tuner pre-amp assembly complete with
 volume/tone controls and tuning scale
 Brand new in makers carton £5.95, faulty £1.95
 Circuit diagram description and setting up procedure for tuner
 assembly described above £0.50
 Motor start capacitors 1.5uf 440vac £1.95
 40 uf 370vac £5.95 4uf 250vac + 100uf £0.55
 LNE mains suppressor 2x5uf + 100nf £0.55
 5 digit 6V electromagnetic counter £1.95
 oval 8 ohm speakers 136x70mm £0.60
 Hour counter (used) 7 digit mains 250V 50Hz £0.95
 LCD display 16 digit 7x5 dots dot matrix £2.50
 Query keyboard 58 key uncased good quality switches £5.00
 CMOS TTL 74HC 74F Linear transistors kits capacitors
 resistors tools etc always in stock
 Please add 75p P&P per order VAT included
JPG Electronics 276 Chatsworth Road Chesterfield S40 2BH
 Access orders (0246) 211202. Callers welcome

Carbon Film Resistors 1/4W E24 series 0.51R to 10MΩ - 1p
 100 off per value - 75p 1000 off in even hundreds per value - £7
 Metal Film 1/4W 10R0 to 1MΩ 5% E12 series - 2p 1% E24 series - 3p
 1/2Watt metal/carbon film E24 series 1R0 to 10MΩ - 112p
 1 Watt metal/carbon film E12 series 4R7 to 10MΩ - 5p
 BC107/8/9 - 12p BC547/8/9 - 8p BC182L 184L - 10p
 BFY50/51/52 - 20p 2N3055 - 50p TIP31A,32A - 25p TIP,41,42 - 40p
Tantalum head subminiature electrolytics (Mids/Volts)
 0-1/35, 0-2/25, 0-4/7.35, 3-3/16, 4-7/16 - 14p 4-7/35 - 15p
 2-2/35, 4-7/25, 10/5 - 15p 4-7/35, 6/8/16 - 16p 10/16, 22/6 - 20p
 22/16 - 30p 33/10 - 30p 47/10 - 35p 100/6 - 40p
Aluminium Electrolytics (Mids/Volts)
 1/50, 2-2/50, 4-7/25, 4-7/50, 10/16, 10/25, 10/50 - 5p 22/16, 22/25 - 6p
 22/50, 47/16, 47/25, 47/50 - 6p 100/16, 100/25 - 7p 100/50 - 12p
 100/100 - 14p 220/16 - 8p 220/25, 220/50 - 10p 470/16, 470/25 - 11p
 1000/25 - 18p 1000/35, 220/25 - 22p 4700/25 - 70p
Miniature Polyester Capacitors 250V Wkg. Vertical Mounting
 -01, -015, -022, -033, -047, -068 - 4p 0-1 - 5p 0-15, -22 - 6p 0-47 - 8p
Mylar Capacitors 100V Wkg. Vertical Mounting E12 Series
 1000p to 8200p - 3p -01 to -068 - 4p 0-1 - 5p 0-15, 0-22 - 6p
Subminiature Ceramic Plate 100V Wkg. E12 Series Vertical Mounting
 2% 1P8 to 47P - 3p 56P to 330P - 4p 10% 390P to 4700P - 4p
 Ceramic plate/disc E6 Series 50V 22P to .047 - 2p
Polystyrene Capacitors 63V Wkg. E12 Series Axial Mounting
 10P to 820P - 3p 1000P to 10,000 - 4p 12,000P - 5p
 1N4148 - 2p 1N4002 - 4p 1N5404 - 14p W01 bridge - 25p
 0A91 - 6p AA143 - 8p W005 - 20p 1N4006 - 6p
 Zener diodes E24 series 3V3 to 33V 400mW - 8p 1 watt - 12p
 L.E.D.'s Red, Green & Yellow 3mm & 5mm - 10p 8mm - 35p
 20mm fuse 0-1A to 5A quick blow - 5p Anti Surge - 8p
 High Speed drills 0-8mm, 1-0mm, 1-3mm, 1-5mm, 2mm - 30p
 Expo Reliant drilling machines 12V d.c. with improved 3-jaw chuck 6.50
 Nicads AA - 80p HP11 - £2 PP3 - £4.20 Universal Chargers - £6.50
 Glass reed switches single pole make contacts - 8p Magnets - 12p
 VAT inclusive. Return postage 25p (free over £5). Lists free.
THE C.R. SUPPLY CO.,
 127 Chesterfield Road,
 Sheffield S8 0RN. Tel: 557771.

Cooke International
 GOOD USED TEST EQUIPMENT ALWAYS AVAILABLE & WANTED
 SCOPES ANALYSERS SIG GENS BRIDGES POWER METERS
 DC - MICROWAVE EQUIPMENT
 Airmec 304 HF Oscillator 60kHz-100MHz 104v output (1) £200
 Dana Model 4500 5 1/2 digit Auto OMM (2) £65
 Dana Model 8110, Auto Time & Frequency 8 digit counter, 0-20MHz £250
 Fluke 871A Differential voltmeter (1) £170
 HP 214A Pulse Generator High power 100V/50 Ohms (1) £185
 HP 431B RF Power meter with lead and mount (6) £250
 HP 606A HF Signal generator 50kHz - 66 MHz 3v output (1) £95
 HP 6080 VHF Signal generator 10 - 420 MHz with Mod. (1) £150
 HP1740A 100MHz General purpose oscilloscope with delay (1) £750
 HP3300A Function generator 0.01-100kHz all modes (1) £150
 HP 3406A Broad band RF sampling voltmeter (1) £265
 Marconi TF 1313A Universal LOR Bridge (1) £250
 Philips PM3370 OC-60MHz dual trace scope with delay (1) £175
 Tektronix 611 storage display (1) £200
 Tektronix 465 DC - 100 MHz dual trace with delay (3) £750
**WIDE RANGE OF ITEMS AVAILABLE - SEND FOR LISTS - COMPETITIVE
 PRICES & BARGAINS TO CALLERS! BULK & TRADE TERMS
 HOURS OF BUSINESS: MON-FRI 9.30 - 5.00
 UNIT 4 FORDINGBRIDGE SITE, MAIN ROAD, BARNHAM,
 BOGNOR REGIS, WEST SUSSEX PO22 0EB
 Tel: 0243 68 5111/2. Fax: 0243 68 2457**

Phone Sarah Holtham
 with your
 classified ad!
01-743 8888
 We now accept payment by
 Access and Visa
**You can also use PE
 Fax Line:
 01-743-3062**

Eproms ex equip all blank and tested: 2764, £1
 ea., £9 for 10; 2756, £2 ea., £19 for 10; 200
 step, stepper motors, 24/12 volts, £3 ea. Add £1
 p&p.
EXTECH, THE COMPUTER CENTRE
 53 Queen Street, Morley LS27 8DB
 Tel: (0532) 537219

**UNUSED AND SURPLUS TO
 REQUIREMENTS**
 10 Relays Misc. voltages and types £10.00 inc. VAT
 30 Potentiometers & Trimmers misc. £6.00 inc. VAT
 10 3/4 Rectangular cermet trimmers PC mount - mixed val
 value £3.00 inc. VAT
 10 Mixed miniature pushbutton switches £2.50 inc. VAT
 20 Mixed 1/2 watt W/W Resistors with variable TAP £4.00 inc. VAT
 10 Miniature Panel Neons £2.00 inc. VAT
 Postage and packing £1.30 per pack.
**BLORE-BARTON LTD Raedham
 House, Burnham Bucks SL1 8AG**

CAMBRIDGE COMPUTER SCIENCE LTD
 5 1/4 inch Disk Drives, 80 Track DSDD £34.00 each
 3" Disk Drives, 40Tk, SSDD £28.00 each
 5.25" Disks, DSDD, 48tpi boxed in 10s £3.00/box £27.00(10)
 Dual Disk Drive Power Supply £20.00 each
 Lead to connect one drive to psu £ 2.00 each
 Single Data lead (BBC Micro to Disk Drives) £ 2.00 each
 Dual Data lead (BBC Micro to 2 Disk Drives) £ 4.00 each
 Dual leads (BBC Micro to 2 Disk Drives) £ 2.00 each
 20 pin dual low profile IC sockets £0.50 (ten) - £ 5.00 (100)
 QWERTY keyboard with Cursor keys,
 function keys & numeric pad. £ 6.00 each
 Hitachi 640 * 200 dot matrix LCD display £ 40.00 each
 Toroidal transformer, mains in, 12V @4A,
 12V @0.4A, 12-0-12 @0.1A, 12-0-12 @0.2A
 & 9-0 @0.2A £4.00 each - £6.00 for 2 - £8.00 for 3
 All items new and boxed. Add 15% VAT to all prices. Prices
 include postage. Add 50p to orders below £5.00.
**Dept PE, 374 Milton Road, Cambridge, CB4 1SU
 Tel: 0223 327602**

TURN YOUR SURPLUS
 ICS transistors etc into cash, immediate
 settlement. WE welcome the opportunity to
 quote for complete factory clearance.
 Contact:
COLES-HARDING & CO.,
 103 South Brink, Wisbech, Cambs.
 ESTABLISHED 15 YEARS
 Tel:0945 584188 - Fax: 0945 588844

☆☆☆ RESISTOR PACKS ☆☆☆
 1/4W 5% CARBON FILM
 10 of each E12 value
 10R to 10M
 Total 730 resistors
£8.00 UK only
 RMOS P.O. Box 3
 USK GWENT NP5 2YF

**SURPLUS/REDUNDANT ELECTRONICS
 COMPONENTS WANTED**
 ICs - Tuners - Transistors - Valves - Diodes etc - any
 quantity considered - immediate payment.
ADM ELECTRONICS SUPPLIES
 Tel:0827 873311 Fax: 0827 874835

★★★ KITS ★★★
 ● Miniature VHF/FM transmitter £3.75 ●
 ● Telephone transmitter (no batteries needed) £6.99 ●
 ● Automatic telephone monitor to start/stop your cassette when
 telephone is used, recording all conversations £8.99 ●
 ● Voice operated switch £9.99 ●
 ● AF/RF signal injector tracer £5.99 ●
 ● Bleeper VHF/FM transmitter £9.99 ●
 ● High power telephone transmitter £7.99 ●
 ● Tricolour car battery monitor £4.25 ● Rogetleep £4.99 ●
 ● Receiver preamp, 15db gain £7.99 ●
 ● Drill speed controller, complete with cable,
 socket, box etc. £9.99 ●
 SAE LIST, P&P Free. Eire and overseas £2
 Access orders accepted by telephone.
 Cheque / P.O. to:
**A.C. Electronics, 99 Greenhead,
 Hednesford, Staffs.**

★ Series X Mixer Kits
 ★ up to 1,000 inputs
 ★ 60+ 100 mm faders, pots,
 panels and audio switches
 ★ 6 auxiliaries
 ★ versions for recording PA,
 radio, disco
 ★ circuit diagrams
 ★ From £9.92
 Send 19p for catalogue to: K. Tek, P.O. Box 172a,
 Surbiton, Surrey KT6 6HN. Tel:01-399-3990

80186 STARTER KITS.
 Limited number. Ex-Development stock.
 Choice of processors, 80186-10 or 8086-2 +
 8089-3 plus the following:
 8087 (5MHz) 8207-8
 8251A 8253PC
 8254 8259AB
 8284A-8 8288
 8289
 Complete kits £90. Please state which
 processor. A number of 5MHz and 8MHz
 8087 coprocessors available separately at
 £70 and £90 respectively. Contact Nikki on
 0242 574528 and ask about 8086 kits.

HYBRID POWER CONTROLS
 ☆ BF HYBRID £7.95
 12 Amp 240 Volt complete Zero Voltage Proportional Heater
 Control (no radio interface).
 ☆ PC1R £3.45
 1 Amp 240 Volt Phase Angle Controller - Light Dimmer
 (requires 220k pot.)
 ☆ PC12R £6.95
 12 Amp 240 Volt Phase Angle Controller - Light Dimmer, Drill S
 peed, Heater Control. (Requires 220k pot.)
 Prices include VAT + p&p 62 PARK ROAD, SWANAGE, DORSET, BH19 2AE
 SAE for details on above products. TELEPHONE: 0929 426400
 Full range of Thyristors, Triacs, Fuses,
 Heatshinks & Firing Circuits etc.
 Trade enquiries welcome

SERVICES

Sample our quality with

A FREE P.C.B

PAYNE ELECTROPRINT LIMITED
 15 years PRINTED CIRCUIT manufacture
 ☆Single/double sided
 ☆Plated Through Hole
 ☆Small or large quantities

Write to : Dept A, Marcus Road,
 Dunkeswell, Nr. Honiton, Devon, EX14 8TT

PCB Design Program for Amstrad PCW8256/8512

Latest version featuring 1:1 scale printout. Now you can make double or single sided PCB's using only a UV light source. Powerful screen editing facilities. All this and more for just £29.99 incl.

Details from: CADsoft Systems, 18 Ley Crescent, Astley Manchester M29 7BD
 ★ Also available for Amstrad CPC664/6128 ★

PCB Design Program for Amstrad CPC664/6128 and Amstrad PCW 8256/8512

Design and manufacture your own PCB's using this powerful yet easy to use utility. Double or single sided boards - 8 pads styles - 5 track widths - plus many other features for only £29.99 incl.
 Details from: CADsoft Systems, 18 Ley Crescent, Astley Manchester M29 7BD

MAKE YOUR OWN PCB's

Just about everything from polishing blocks to plated through hole equipment.
 Very keen prices - discount on quantity.
 S.A.E. for complete price list or telephone:
Ward Electronics,
 27 North Street, Redruth, Cornwall TR15 1HJ
 Tel: 0209 211050

Printed Circuit Board Design, Using Computer Aided Design,

Photoplotting,
 Phototype PCB's
 Special reductions for new clients

Call Neville Sanderson on: 0532-870253
N.C.A. DESIGNS

Use Practical Electronics magazine as a showcase for your products!

For Electronic Design and PCB Manufacture call

PROTO DESIGN

Unit 8, Ilford Trading Estate
 Paycocke Road Basildon
 Essex SS14 4DR
 Tel: 0268 289923

IS YOUR
 CLASSIFIED AD
 A TIGHT SQUEEZE?

STRETCH OUT

**in display pages of PE!
 Phone Sarah Holtham on
 01-743-8888 for details!**

DESIGN PROBLEMS?

Solve them now! Low cost electronic design service. For full details send S.A.E. to:
 Spiretroniks, 2 Woodclose,
 Chesterfield, Derbyshire S42 6SD
 Tel: 0246 278280

WORKSHOP SERVICE MANUALS

Video Recorders - £12.50
 Most Colour TV, Audio, Test, Vintage, Amateur etc. £6.00
 Please state Make/Model/Type with order.
 FREE Catalogue Unique Repair and Data Guides with all orders or LSAE for your copy.
MAURITON ELECTRONICS LTD (PE),
 8 Cherry Tree Road, Chinor, Oxfordshire OX9 4QY
 Tel: (0844) 51694

TECHNICAL INFO SERVICES (PE)

76 Church St., Larkhall, Lanarkshire ML9 1HE
 Phone 0698 884585 Mon-Fri, 9-5
 any other time 0698 883334 FOR FAST QUOTES
WORLD'S LARGEST COLLECTION SERVICE MANUALS Most unobtainable elsewhere. Prices range from only £4.50 - large s.a.e. any quotation, no obligation to buy.
WORLD'S SOLE Suppliers of TV & Video Repair manuals, etc. from TV TECHNIC, Thorn etc. Every published service sheet in stock, supplied full size, not bits & pieces. CTV's or any combination £3.50 plus Lsae, any other single item £2.50 plus Lsae. Complete Circuit Sets for most Videorecorders only #7 set (no serv. shts made).
LSAE for QUOTATIONS plus GIANT CATALOGUE NEWSLETTERS
BARGAINS FREE S/SHT as available.
 Comprehensive TV Repair Manual £9.50. Complete Radio Service and Repair Course £9.50. Complete Repair & Service Manuals Mono TV £12.50. CTV £17.00. Video £19.50. Complete Repair Data with circuit - Mono TV £9.50. CTV £12.50. Video £10.50.
£3.00 plus LSAE BRINGS THE ONLY COMPREHENSIVE SERVICE SHEETS & MANUALS, CATALOGUES plus FREE CHASSIS GUIDE and £4.00 OF VOUCHERS

Printed Circuit Board Design, Using Computer Aided Design Photoplotting, Phototype PCB's
Special reduction for new clients!

Call Neville Sanderson on: 0532-870253
N.C.A. DESIGNS

Program Now

The Advanced Programmers' Journal
The one tool every programmer should have!
 From all good newsagents-£1.50

SURVEILLANCE

Omicron 2

The practical surveillance solution

- ┘ Ideal eavesdropper or baby monitor
- ┘ Less than 1/2 matchbox size
- ┘ Absolutely shockproof housing
- ┘ Built-in sensitive microphone
- ┘ Battery life 72 hrs (Alkaline)
- ┘ Full 12 months warranty



Simply clip Omicron 2 to battery and hide - no adjustments, no fiddling, no fuss. Hear every sound perfectly on an ordinary FM radio up to 1/4 mile away. This must be the easiest to use, best value surveillance device available.

No quibble 14 day money back guarantee.

TRADE ENQUIRIES: **MILLEA ELECTRONICS** Tel: (0484) 460103
 WELCOME 470-472 LEYMOOR ROAD, HUDDERSFIELD, HD7 4GF

NEW VHF MICROTRANSMITTER KIT. tuneable 80-115 Mhz, 500 metre range, sensitive electret microphone, high quality PCB. SPECIAL OFFER complete kit **ONLY £5 POST FREE.** Access orders telephone 021 411 1821. Cheques/ P.O.'s to: **Quantek Electronics Ltd, (Dept P.E.), 45a Station Road, Northfield, Birmingham, B31 3TE**
Surveillance devices, lasers, Tesla coils, scramblers, ultrasonic and many more, over 150 designs. Send SAE to: **Plancentre, Old Wharf, Dynock Road, Ledbury HR8 2HS**

MISCELLANEOUS

Geiger tubes £29.00. Counters - fit your tubes £25. Silicon wafers £1.50. Universal laboratory camera £40.00.
Tel: Mr. Matthews on 040-376 236
FOR SALE. Cheetah 87 Telex and BT Statesmen Telephone System. Tel: 031 2202257

Aluminium Electrolytic Capacitors (Axial) 2200/25V - 50p, 4700/25V - 85p, **Metallised Polyester Capacitors MKS4** 1.0/250V - 40p, **Resistor Networks SIL** 8 Pin 4 * 2K2 - 10 for £2.10, **Heatsinks TO-220** 14 deg.C/W Type TV1500 - 20p, **Heatsinks TO3** 7.1 deg.C/W Type TV3 - 25p, **Microprocessor IC's** 8748HD NEC 1K bytes EPROM - £9.50, 8748HD NEC 1K bytes EPROM - £10.50, Please add 75p p&p. VAT inc. Cheque/P.O. to: **Chilworth Electronics, Sycamore, Blacksmith Lane, Chilworth, Guildford, Surrey GU4 8NG** Tel: 0483 62772

PROFESSIONAL 19" ENCLOSURES FOR YOUR PROJECTS AT AMAZING PRICES. These beautifully made 1U high 19" rack style cases are complete with +5v, +/- 12v power supplies and mains IEC inlet. Would cost well over £100 new, a limited number only production overrun offered as new but untested for only £25 plus £4.50 P&P. Cheques to : B. Thurlow, SHDS/2 Stephenson House, 75 Hampstead Road, London.



No. 1 LIST BAKERS DOZEN PACKS

All packs are £1 each, if you order 12 then you are entitled to another free. Please state which one you want. Note the figure on the extreme left of the pack ref number and the next figure is the quantity of items in the pack, finally a short description.

- BD2 5 13A spurs provide a fused outlet to a ring main where devices such as a clock must not be switched off.
- BD7 4 In flex switches with neon on/off lights, saves leaving things switched on.
- BD9 2 6V 1A mains transformers upright mounting with fixing clamps.
- BD11 1 6 1/2" speaker cabinet ideal for extensions, takes our speaker. Ref BD137.
- BD13 12 30 watt reed switches, it's surprising what you can make with these - burglar alarms, secret switches, relay, etc., etc.
- BD22 2 25 watt loud speaker two unit cross-overs.
- BD29 1 B.O.A.C. stereo unit is wonderful breakdown value.
- BD30 2 Nicad constant current chargers adapt to charge almost any nicad battery.
- BD32 2 Humidity switches, as the air becomes damper the membrane stretches and operates a microswitch.
- BD42 5 13A rocker switch three tags so on/off, or change over with centre off.
- BD45 1 24hr time switch, ex-Electricity Board, automatically adjust for lengthening and shortening day original cost £40 each.
- BD49 10 Neon valves, with series resistor, these make good night lights.
- BD56 1 Mini uniswitch, one use is for an electric jigsaw puzzle, we give circuit diagram for this. One pulse into motor, moves switch through one pole.
- BD59 2 Flat solenoids - you could make your multi-tester read AC amps with this.
- BD67 1 Suck or blow operated pressure switch, or it can be operated by any low pressure variation such as water level in water tanks.
- BD91 1 Mains operated motors with gearbox. Final speed 16 rpm, 2 watt rated.
- BD103A 1 6V 750mA power supply, nicely cased with mains input and 6V output leads.
- BD120 2 Stripper boards, each contains a 400V 2A bridge rectifier and 14 other diodes and rectifiers as well as dozens of condensers, etc.
- BD122 10m Twins screened flex with white pvc cover.
- BD126 10 Very fine drilled for pcb boards etc. Normal cost about 80p each.
- BD132 2 Plastic boxes approx 3/4" cube with square hole through top so ideal for interrupted beam switch.
- BD134 10 Motors for model aeroplanes, spin to start so needs no switch.
- BD139 6 Microphone inserts - magnetic 400 ohm also act as speakers.
- BD148 4 Reed relay kits, you get 16 reed switches and 4 coil sets with notes on making c/o relays and other gadgets.
- BD149 6 Safely cover for 13A sockets - prevent those inquisitive little fingers getting nasty shocks.
- BD180 6 Neon indicators in panel mounting holders with lens.
- BD193 6 5 amp 3 pin flush mounting sockets make a low cost disco panel. Need cable clips.
- BD196 1 In flex simmerstat - keeps your soldering iron etc. always at the ready.
- BD199 1 Mains solenoid, very powerful, has 1in pull or could push if modified.
- BD201 8 Keyboard switches - made for computers but have many other applications.
- BD210 4 Transistors type 2N3055, probably the most useful power transistor.
- BD211 1 Electric clock, mains operated, put this in a box and you need never be late.
- BD221 5 12V alarms, make a noise about as loud as a car horn. Slightly soiled but OK.
- BD242 2 6in x 4in speakers, 4 ohm made from Radiomobile so very good quality.
- BD252 1 Panostat, controls output of boiling ring from simmer to boil.
- BD259 50 Leads with push-on 1/4in tags - a must for hook-ups - mains connections etc.
- BD263 2 Oblong push switches for bell or chimes, these can mains up to 5 amps so could be foot switch if fitted into pattress.
- BD268 1 Mini 1 watt amp for record player. Will also change speed of record player motor.
- BD275 1 Guitar mic - clip-on type suits most amps.
- BD283 3 Mild steel boxes approx 3in x 3in x 1in deep - standard electrical.
- BD293 50 Mixed silicon diodes.
- BD296 2 Car plugs fit into lighter socket.
- BD305 1 Tubular dynamic mic with optional table rest
- BD400 4 Books, useful for beginners, describes amplifiers, equipment and kit sets.
- BD653 2 Miniature driver transformers. Ref. LT44. 20k to 1k centre tapped.
- BD553a 2 3.5V relays each with 2 pairs changeover contacts.

Most other packs still available and you can choose any as your free one.

VERY POWERFUL 12 VOLT MOTORS - 1/2 HORSEPOWER Made to drive the Sinclair C5 electric car but equally adaptable to power a go-cart, a mower, a rail car, model railway, etc. B brand new. Price £15.00 plus £2.00 postage. Our ref 15P8.

MAINS TRANSFORMER Upright mounting normal mains input, gives 26v at 3.5A so should be ideal for big amplifier, etc. Price only £4. Our ref 4P24, please add £1 postage

POWERFUL IONISER

Generates approx 10 times more IONS than the ET1 and similar circuits. Will refresh your home, office, workshop, etc. Makes you feel better and work harder - a complete mains operated kit, case included. £12.50 plus £2 postage. Our ref 12P5/1.



POTENTIAL PROFIT MAKERS We can offer shop rejects and customer returns covering a range of clock radios, cassette radios, cassette players, in-car cassette/radios, etc., all of which should be repairable. If you buy four of a type we will give you one extra free of charge. All are by Fair Astor makers, sold under the trade names of Sony, Matsui, Panasonic, etc. You will buy so cheaply that even if you are unlucky and cannot repair them you will be buying spares at a very low price. **CLOCK RADIOS** Digital clock display with snooze, alarm and brightness controller. 2 band radio and built-in speaker. Price £5 each. Our ref 5P131. **WALKMAN TYPE PERSONAL CASSETTE PLAYERS** Complete with stereo headphones. Price £5 each. Our ref 5P132. Ditto, with graphic equaliser. £6 each. Our ref 6P11. **CLOCK RADIOS** AM/FM stereo, built-in speaker and light weight headphones. Price £4 each. Our ref 4P33.

ECHO BOX Intended to make dolls and robots talk. These units record speech and other sounds then play back the sounds a few seconds after hearing it. Basically the unit consists of a FET microphone, a micro-processor and lots of ICs, transistors, etc., on a pcb, coupled to a 2in speaker. All put together in a case size approx 4 1/2in x 2 3/4in x 1 1/4in deep. In addition to talking back undoubtedly these models could, with a few alterations, be made to perform functions in response to sound frequencies. Price £5 each. Our ref 5P130.



ATARI 65XE COMPUTER

At 64k this is most powerful and suitable for home and business. Brand new, complete with PSU TV lead, owner's manual and six games. Can be yours for only £45 plus £3 insured delivery

CAMERAS. We have made a big purchase and can offer you three cameras all by famous makers. Kodak etc. one disk and two different instant cameras. All in first class condition, believed in perfect working order. sold as untested. 3 for £10 inc. V.A.T. which must be a bargain if only for the lenses, flash guns etc. Our ref 10P58

BD400 for books, useful for beginners, describes amplifiers, test equipment and kit sets

TIME AND TEMPERATURE LCD MODULE This is a 12 hour clock, a Celsius thermometer, a Fahrenheit thermometer, a too hot alarm and finally a too cold alarm. Nice size approx 50mm x 20mm, with 12,7mm digits which clearly display the time or temperature. Requires only a 1.5v battery and a few switches. Comes complete with circuit diagram and explanation. Price £6. Our ref 6P12

40 WATT THREE-WAY CAR SPEAKER SYSTEM Woofer, mid-range and tweeter, all assembled in a shell mounted case, size 180mm long x 100mm deep. Really beautifully made. 40ohm impedance. New and tested. £10 each. Our ref 10P64

9in MONITOR made for ICL, uses Philips black and white tube. Brand new and complete but uncased. £16 plus £5 post.

DATA RECORDERS ACORN for Acorn Electron, etc., reference number ALF03, with TV lead, manual and PSU. Brand new. Price £10 plus £1 50 post. Order ref 10P44. ATARI XC12 for all their home computers. With leads and handbook. Brand new. Price £15 plus £2 post. Order ref 15P20

JOYSTICK FOR ATARI OR COMMODORE for all Atan and Commodore 64 and Vic20. New. Price £5. Our ref 5P126

EXTRA SPECIAL OFFER We will supply the Atari 65XE, data recorder XC12, joystick and six games for £62 50 plus £4 insured delivery

SUB-MIN TOGGLE SWITCH Body size 8mm x 4mm x 7mm SBDT with chrome dolly fixing nuts. 4 for £1. Order Ref. BD649

Re-CHARGEABLE NICADS 'D' SIZE These are tagged for easy joining together but tags, being spot welded, are easy to remove. Virtually unused, tested and guaranteed. £2 00 ref 2P141 or 6 wired together for £10 00 ref 10P47

LASER TUBE

Made by Philips Electrical. New and unused. This is helium-neon and has a typical power rating of 1.6mW. It emits random polarised light and is completely safe provided you do not look directly into the beam when eye damage could result. Do not use in the presence of children unless a diverging lens is fitted. **DON'T MISS THIS SPECIAL BARGAIN!** Price £29.95 plus £3 insured delivery.

POWER SUPPLY FOR PHILIPS LASER is now available in kit form. Price £15 plus £2 postage or made-up ready-to-use at £20 plus £2.50 postage. Our ref 15P16 for the kit and 20P8 for the made-up version. Battery operated p.s.u. now available £15.

PAPST AXIAL FAN-MANUFACTURERS REF NO. TYP4560N. This is mains operated, 15 watt rating and in a metal frame with metal blades so OK in high temperatures. Body size approx 4 3/4" square x 1 3/8" thick. £6.00 each, plus £1 00 postage. Our ref 6P6

ORGAN MASTER



is a three octave musical keyboard. It is beautifully made, has gold plated contacts and is complete with ribbon cable and edge connector. Brand new, only £15 plus postage. Our ref 15P15

MUSIC FROM YOUR SPECTRUM 128 We offer the Organ Master three octave keyboard, complete with leads and the interface which plugs into your 128. You can then compose, play, record, store, etc., your own music. Price £19 plus £3 special packing and postage. Order ref 26P2

20A DOUBLE POLE RELAY WITH 12V COIL complete with mounting brackets made by the Japanese Omron Company. Price £2 each. Our ref 2P173A

TORROIDAL MAINS TRANSFORMER with twin outputs 6.3V 2A and 12V 600mA, so ideal for FDD power supply. Price £5. Our ref 5P122

HAND-HELD VIDEO LAMP Mains operated and will enable you to take professional standard videos. Made by the famous Ferguson Company. This uses a 1000w lamp in a fan cooled, hand-held and hand-switched metal housing. Comes complete with optional barn-door assembly and camera bar. Obviously intended to retail at over £60, we offer these at £30 each plus £3 insured delivery. Our ref 30P3

OUR ALADDIN'S CAVE You may be a new reader and not know that we have a shop at 12 Boundary Road, Hove, where you can go and have a browse around at our assortment of 'goodies'. Unfortunately, because of staff shortages, we cannot open on Saturdays yet, so the hours are 9.30am to 5.00pm, Monday to Friday. We of course still serve callers at 250 but request that you bring a completed order form as 250 is really the mail order depot.

J & N BULL ELECTRICAL

Dept PE, 250 PORTLAND ROAD, HOVE BRIGHTON, SUSSEX BN3 5QT

MAIL ORDER TERMS: Cash, PO or cheque with order. Orders under £20 add £1.50 service charge. Monthly account orders accepted from schools and public companies. Access and B/card orders accepted minimum £5. Phone (0273) 734648 or 23500.

POPULAR ITEMS

Some of the many items described in our current list which you will receive if you request it



DOUBLE MICRODRIVES We are pleased to advise you that the Double Microdrives which we were offering at about this time last year as being for the 'OL', 'OPD' and several other computers are again available, same price as before namely £5. Our ref 5P113

NOISE FILTERS - MAINS INPUT PLUG TYPE Japanese made this is a chassis mounting block with a built in noise filter to cut out surges and voltage peaks which could interfere with and possibly even damage your equipment. These are easy to mount and have a flange with two fixing holes. They take the standard 3 flat pin plug, 2amp model. Price £3 each. Our ref 3P50

LEAD LAMP Motorists' Special Normal hand-grip type holder, with glass cover to protect the lamp and further protection in the form of a wire guard with a hook for hanging. Ideal as a loft light or for car repairs, etc. Takes 60w lamp Has good length flex. Price £4. Our ref 4P31

PHONE LEADS 3 metres long, correctly colour coded, one end has flat plug which fits standard BT socket, other end has tag connectors. 2 for £1. Our ref BD639

SOFTWARE FOR REMAKING Just arrived. Large quantity of mainly games. All re on normal tape spools in cassette holders and should be suitable for wiping out and re-making into games or programmes of your own design. We offer 5 different for £2 or 100 assorted for £20. Important note. We cannot say which titles you will get nor accept orders for specified titles or 'so many, all different', etc., so only order if you can take them as they come. Order ref 5 for £2 is 2P224, 100 assorted is 20P10.

VERY USEFUL MAGNETS Flat, about 1in long, 1/2in wide and 1/4in thick. These are polarised on their faces which makes them ideal to operate reed switches in doors and windows or to hold papers or labels, etc., to metal cabinets, or even to keep cupboard doors firmly closed. Very powerful. 6 for £1. Our ref BD274(a)

FREE POWER! Can be yours if you use our solar cells - sturdily made modules with new system bubble magnifiers to concentrate the light and so eliminate the need for actual sunshine - they work just as well in bright light. Voltage input is 45-uolt join in series to get desired voltage - and in parallel for more amps. **Module C** gives 400mA, Price £2. Our ref. 2P199 **Module D** gives 700mA, Price £3. Our ref. 3P42

SOLAR POWERED NI-CAD CHARGER 4 Ni-Cad batteries AA (HP7) charged in eight hours or two in only 4 hours. It is a complete, boxed ready to use unit. Price £6. Our ref. 6P3

3 VOLT MOTOR Very low current so should be very suitable for working with solar cells. £1 each. Our ref BD681.

MINI SPEAKERS to use instead of headphones with your personal stereo - simply plug in to earphone socket. Excellent sound quality, only £4 per pair. Our ref 4P34

SEALED LEAD ACID BATTERIES Japanese made re-chargeable and maintenance-free. Leak-proof construction, so could be used in any position. Long life expectancy - usually four to five years. 12v 2.6Ah. £10 each. Our ref 10P59. 6v 1Ah. £5 each. Our ref 5P135

INNER EAR STEREO HEADPHONES Ideal for lady listeners as they will not mess up your hair! Come complete in a neat carrying case. Price £3. Our ref 3P56

SWITCH AC LOADS WITH YOUR COMPUTER This is easy and reliable if you use our solid state relay. This has no moving parts, has high input resistance and acts as a noise barrier and provides 4kW isolation between logic terminals. The turn-on voltage is not critical, anything between 3 and 30V, internal resistance is about 1k ohm. AC loads up to 10A can be switched. Price is £2 each. Ref. 2P183

METAL PROJECT BOX Ideal size for battery charger, power supply etc.; sprayed grey, size 8in x 4 1/4in x 4in high, ends are louvred for ventilation other sides are flat and undrilled. Order Ref. 2P191. Price £1.

4-CORE FLEX CABLE. Cores separately insulated and grey PVC covered overall. Each copper core size 7/0, 2mm. Ideal for long telephone runs or similar applications even at mains voltage. 20 metres £2. Our ref 2P196 or 100 metres coil £8. Order ref. 8P19

6-CORE FLEX CABLE. Description same as the 4-core above. Price 15 metres for £2. Our ref. 2P197 or 100 metres £9. Order ref. 9P1.

13A PLUGS Good British make complete with fuse, parcel of 5 for £2. Order ref. 2P185.

13A ADAPTERS Takes 2 13A plus packet of 3 for £2. Order ref. 2P187

28V 0-20V Mains transformers 2 1/2 amp (100 watt) loading, tapped primary, 200-245 upright mountings £4. Order ref. 4P24

BURGLAR ALARM BELL - 8" gong OK for outside use if protected from rain, 12V battery operated. Price £8. Ref. 8P2

24 HOUR TIME SWITCH - 16A changeover contacts, up to 6 on off per day. Nicely cased, intended for wall mounting. Price £8. Ref. 8P6.

CAPACITOR BARGAIN - axial ended, 4700µF at 25V. Jap made, normally 50p each, you get 4 for £1. Our ref. 613

SPRING LOADED TEST PRODS - Heavy duty, made by the famous Bulgin company, very good quality. Price 4 for £1. Ref. BD597

3-CORE FLEX BARGAIN No. 1 - Core size 1.25mm so suitable for long extension leads carrying up to 13 amps, or short leads up to 10 amps. 15mm for £2. Ref. 2P190.

3-CORE FLEX BARGAIN No. 2 - Core size 1.25mm so suitable for long extension leads carrying up to 13 amps, or short leads up to 25A. 10m for £2. Ref. 2P190

ALPHA-NUMERIC KEYBOARD - This keyboard has 73 keys giving trouble free life and no contact bounce. The keys are arranged in two number pad, board size is approx. 13" x 4" - brand new but offered at only a fraction of its cost, namely £3 plus £1 post. Ref. 3P27.

WIRE BARGAIN - 500 metres 0.7mm solid copper tinned and p.v.c. covered. Only £3 plus £1 post. Ref. 3P31 - that's well under 1p per metre, and this wire is ideal for push on connections

1/8TH HORSEPOWER 12 VOLT MOTOR Made by Smilts, the body length of this is approximately 3in, the diameter 3in and the spindle 5/8th of an inch diameter. It has a centre flange for fixing or can be fixed from the end by means of 2 nuts. A very powerful little motor which revs at 3,000 rpm. We have a large quantity of them so if you have any projects in mind then you could rely on supplies for at least two years. Price £6. Our ref 6P1, discount for quantities of 10 or more.

STEREO HEADPHONE AMPLIFIER Very sensitive. A magnetic cartridge or tape head will drive it. Has volume control and socket for stereo headphones. 3v battery operated. £1 each. Our ref BD686.

FET CAPACITOR MICROPHONE EAGLE CI200 Output equivalent to a high class dynamic microphone while retaining the characteristics of a capacitor microphone. Price £1. Our ref BD646.

SUB-MIN TOGGLE SWITCH Body size 8mm x 4mm x 7mm SBDT with chrome dolly fixing nuts. 4 for £1. Our ref BD649

SUB-MIN PUSH SWITCH DPDT. Single hole fixing by hexagonal nut. 3 for £1. Our ref BD650

DISPLAY 16 CHARACTER 2 LINE As used in telephone answering and similar machines. Screen size 85mm x 36mm x 9.3mm. Alpha-numeric, dot matrix module with integral CMOS micro processor. LCD display. Made by the EPSON Company, reference 16027AR. Price £10. Our ref 10P50

PE COMPETITION

ED'S NEW DIALEMMA

HOW PHONEY CAN YOU GET?

MUCH MORE IF YOU WIN ONE OF THESE FIVE TELEPOINT PERSONAL TELEPHONES!



Kindly made available by Shaye Communications

**YOU'VE READ THE REVIEW
NOW ENTER THE CHATTER BOX.
ANSWER FOUR SIMPLE QUESTIONS,
COMPLETE THE SURVEY QUERIES, AND
YOUR NAME WILL BE PUT IN THE DRAWER
FOR THE DRAW ON MAY 31ST 1989**

The first five names pulled out by our switchboard dazzer will each win a Forum Telepoint handset. Become the envy of your friends - be one of the first to own the very latest in Hi-tech Telephonology! Shaye promise we shall be among the first to receive Forum handsets once production starts in mid-1989.

HOW TO ENTER:

Answer all questions on the entry form and send to: Practical Electronics, Telepoint Competition, 193 Uxbridge Road, London W12 9RA. THE EDITOR'S DECISION IS FINAL!

TELEPOINT ENTRY FORM

Study these seven questions and put a circle around the answers you think are most appropriate (one circle for each question!).

1. When was the first communications satellite launched?

1955 1962 1975

2. Was it called -

Astra Buzbysat Telstar

3. Who is usually credited with inventing the telephone?

Hans Fernsprecher Guglielmo Marconi

Alexander Bell

4. When did he do so ?

1812 1861 1914

5. How much do you like the new cover style?

Very Quite Don't care Not very Not at all

6. How much do you like the new interior style?

Very Quite Don't care Not very Not at all

7. How much would you like more Easi-build circuits?

Very Quite Don't care Not very Not at all

NAME AND ADDRESS (IN BLOCK LETTERS):

.....
.....
.....

Post Code:

The winners of the Astra satellite TV aerials will be announced next month!

By the time you read this the Monopolies and Mergers Commission may have made a decision on whether to allow a proposed takeover of Plessey to go ahead. The 'predators', as the newspapers call them, are GEC and Siemens of West Germany, who would set up a joint company for the purpose.

All this started to happen last November, and you may have been wondering why I haven't mentioned it before, considering that such a massive re-grouping would be highly significant to the whole UK electronics industry. Well, I was repeatedly frustrated by a whole series of new developments affecting GEC. Several times, as I was poised with fingers over the keyboard ready to write a report, something else would happen to change the whole picture.

Most important was a 'phantom bid' for GEC itself. This came from a company called Metsun, specially formed for the

INDUSTRY



NOTEBOOK

Other businesses in the two groups could well be involved if the takeover succeeded, for example medical equipment (already part of the GE-GEC deal) and semiconductors. And this brings me to another significant change of ownership in the UK electronics industry. In the April 1988 issue I concentrated on the semiconductor field with particular emphasis on the uncertain future of Inmos, the firm responsible for the Transputer. I remarked "It's no secret that Thorn-EMI wants to sell Inmos" and "... this once bright hope of state enterprise will probably fall into foreign hands."

Well, sadly, this has in fact happened – or seems imminent at the present time of writing. Ironically, though, Inmos is probably going back to being a state-controlled business again – not British but French! The present UK government sold off its majority shareholding in Inmos to Thorn-EMI because it is against nationalisation

MUSICAL CHAIRS

BY TOM IVALL

The frenetic takeover and merger activity among the electronics giants at the moment is not as counter-productive as may at first appear. New pathways to development may open – if it all works out.

but not, apparently, big enough to go it alone. "The opening up of the telecommunications markets" it said recently "will lead to a world-wide struggle between competitors to force one another out of the market."

Like GEC, Siemens doesn't want to rely on maintaining its world market share in telecoms by internal expansion alone. The R&D costs necessary for keeping abreast of competitors are a very great financial burden for a single company. So collaboration with another large concern seems to be the immediate answer. If the Plessey takeover did succeed, Siemens would have a 40% interest in GPT, while still keeping its own telecoms product line. GEC would acquire a 50% interest in Siemens' military electronics business. Thus each partner would get some access into the other's existing markets.

purpose by an international group of electronics/communications companies and bankers. Relying on certain rumblings of discontent from GEC shareholders, Metsun planned to acquire the group and dismember it into what it saw as a more efficient commercial deployment of operations.

As things turned out, GEC threw a defensive spanner into Metsun's works by announcing a tie-up with the American giant General Electric on several joint ventures to improve the two companies' competitiveness in European markets. Thus GEC became much less vulnerable, wedged supportively as it was between GE and Siemens, respectively the second and fourth biggest electrical/electronic companies in the world. Soon after this, a powerful member of the Metsun consortium, AT&T of America, withdrew from the takeover plan and the whole project collapsed.

You may remember that GEC once tried to take over Plessey on its own (see my report in the March 1986 issue). The main idea of GEC was to make itself bigger in the telecommunications equipment business and thereby achieve a better share of the world market. But this plan was vetoed by the Monopolies and Mergers Commission.

Subsequently, as I reported in February 1988, Plessey and GEC agreed to co-operate just on the manufacture and marketing of telecoms switching equipment, which is now largely electronic. This led to the formation of a joint-venture company called GEC-Plessey Telecommunications (GPT), which now has annual sales of over £1 billion and a foot in the US market through its subsidiary Stromberg-Carlson over there.

Well, GPT is now a major factor in the latest proposed takeover of Plessey. Siemens is already a big player in public telecommunications networks (third largest in the world), switching systems and components,

and believes that the British taxpayer should not be expected to support loss-making concerns. Thorn-EMI did some cost-cutting but was unable to get Inmos into a satisfactory state or profitability. It has now sold the vlsi company to the Thomson group, which is controlled by the French state.

To be more precise, the majority shareholding in Inmos will go to the holding company of SGS-Thomson Microelectronics BV, based in the Netherlands. This was formed last year when the Italian chip firm SGS was merged with the semiconductor business of Thomson. It seems that Thorn-EMI will continue to have a shareholding in Inmos but probably a small one.

Obviously there's something of an entente cordiale going on between Thorn-EMI and Thomson. You'll recall that it was Thomson to whom the UK company sold its Ferguson radio and television set making business not long ago.

So what is the reason for all these bids, mergers, takeovers, joint ventures and so on in the electronics industry? Why can't all these firms just settle down and get on with the job of making and selling electronics products without so much fuss about ownership?

The mere facts as outlined above don't explain very much. From a financial viewpoint it's obviously something to do with firms needing to maintain or improve market share and profits, and thereby satisfy their shareholders, in a very competitive environment. But saying this makes it sound like some automatic process working on its own, a mere collection of blind reflexes. Nor does the financial explanation, which revolves around market value rather than use value, take account of the technology and its development. In a later report I hope to explore these questions more deeply, because conventional explanations only seem to deal with the "how" and not the "why".

PE

PRACTICAL ELECTRONICS BOOK SERVICE

Here is your Editor's choice of books he thinks will be of interest to electronics and computer enthusiasts

BEGINNERS AND EARLY STARTERS

NEW Mini-Matrix Board Projects.
R.A.Penfold. 112 pages. £2.50.
Order Code BP99

Shows a selection of 20 useful and interesting circuits that can be built on a mini-matrix board of 24 holes by 10 copper strips in size - an ideal book for early experimenters.

NEW From Atoms to Amperes.
F.A.Wilson. 160 pages. £2.95.
Order Code BP254.

For the absolute beginner, clearly explaining the fundamentals behind the whole subject of electricity and electronics.

NEW Electronic Projects for Beginners.
F.G.Rayer. 128 pages. £1.95.
Order Code BP48

Specially for the newcomer to electronics who is looking for a book containing a wide range of easily made projects. Some circuits need no soldering and many others show actual component and wiring layouts.

Electronics Build and Learn
R.A.Penfold. 128 Pages. £5.95.
Order Code PC 101

Combining theory and practice, the book describes a circuit demonstrator unit that is used in subsequent chapters to introduce common electronic components and circuit concepts, complete with practical experiments.

Practical Electronic Building Blocks
R.A.Penfold. There are two books -
Book 1 : 128 pages. £1.95.
Order Code BP117
Book 2 : 112 pages. £1.95.
Order Code BP118

Book 1 is about oscillators and gives circuits for a wide range, including sine, triangle, square, sawtooth and pulse waveforms and numerous others from voltage controlled to customised ic types. Book 2 looks at amplifiers, ranging from low level discrete and opamp types to ic power amps. A selection of mixers, filters and regulators is included.

30 Solderless Breadboard Projects
R.A.Penfold. Two books each of 160 pages. Book 1 : £2.25. Order Code BP107. Book 2 : £2.25. Order Code BP113.

Each project is designed for building on a Verobloc breadboard and is accompanied by a description, circuit and layout diagrams and relevant constructional notes. Many of the components are common to several projects. Book 1 covers linear devices, and Book 2 covers cmos logic chips.

Beginners Guide to Building Electronic Projects R.A.Penfold. 112 pages. £1.95. Order Code BP 227
Shows the complete beginner how to tackle the practical side of electronics and includes simple constructional projects.

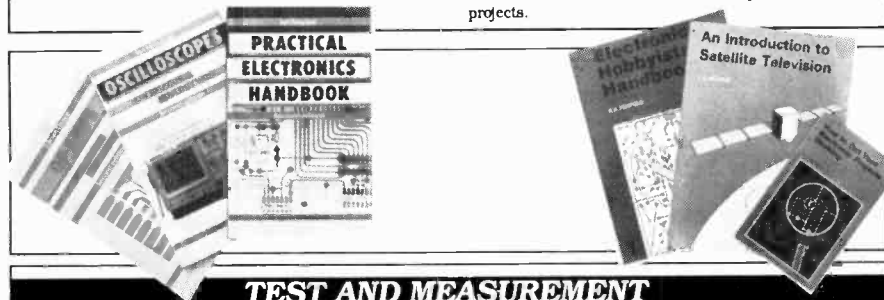

TEST AND MEASUREMENT

How to Get Your Electronic Projects Working.
R.A.Penfold. 96 pages. £2.50.
Order Code BP110.

Essential reading for anyone who wants first-time success in project assembly. Covers tracing mechanical faults as well as testing for failures of active and passive components of most types.

Modern Electronic Test Equipment
K.Brindley. £6.95.
Order Code NT4

Detailed information and discussions on analog and digital meters, oscilloscopes, signal sources, frequency, time and event counters, spectrum and logic analysers, displays and other test equipment.

Getting the Most from Your Multimeter
R.A.Penfold. 112 pages. £2.95.
Order Code BP239

There's more to what you can do with a meter than meets the casual eye. The book covers the basics of what you can do with analogue and digital meters and discusses component and circuit testing.

Oscilloscopes
I.Hickman. £6.95.
Order Code NT3

Subtitled 'How to Use Them, How They Work' the book is illustrated with diagrams and photographs and is essential reading for any one who wants to know about scopes, from first principles to practical applications.

SATELLITE TV

***NEW* Satellite TV Installation Guide - 2nd edition John Breeds.**
£11.95. Order Code STV1

Full of vital information for any competent diyer who wishes to install a satellite tv antenna and obtain optimum reception quality.

An Introduction to Satellite Television

F.A.Wilson. 112 pages. £5.95.
Order Code BP195

Informative answers to many of the questions about this communications revolution. The information is presented on two levels, one aimed at the complete beginner, the other at professional engineers and serious amateur enthusiasts.

AUDIO AND MUSIC

Introducing Digital Audio
I.Sinclair. 112 pages. £5.95.
Order Code PC102

A non-mathematical introduction to the new digital technology, discussing the principles and methods involved in devices such as cd, dat and sampling.

Electronic Music Projects
R.A.Penfold. 112 pages. £2.50.
Order Code BP74

24 practical constructional projects covering fuzz, wah, sustain, reverb, phasing, tremolo etc. The text is split into four sections covering guitar, general, sound generation and accessory projects.

More Advanced Electronic Music Projects
R.A.Penfold. 96 pages. £2.95.
Order Code BP174

Complementing BP74 by covering more advanced and complex projects including flanging, chorus, ring modulation, plus a selection of drum, cymbal and gong circuits.

NEW Computer Music Projects
R.A.Penfold. 112 pages. £2.95.
Order Code BP173

Shows how home computers can produce electronic music and covers sequencing, analogue and Midi interfacing, digital delay lines and sound generators.

Practical Midi Handbook
R.A.Penfold. 160 pages. £5.95.
Order Code PC103

A practical how-to-do-it book for musicians and enthusiasts who want to exploit the capabilities of Midi. Covers keyboards, drums, sequencers, effects, mixers, guitars, and computer music software.

Midi Projects
R.A.Penfold. 112 pages. £2.95.
Order Code BP182

Practical details of interfacing many popular home computers with Midi systems, and also covering Midi interfacing to analogue and percussion synths.

NEW Electronic Synthesiser Construction.

R.A.Penfold. 112 pages. £2.95.
Order Code BP185.

Even relative beginners should find the monophonic synthesiser described here within their capabilities if the book is thoroughly read. Individual aspects of the synth are dealt with separately and pcb designs are shown for the main modules.

DIGITAL AND COMPUTING

NEW A Concise Introduction to MS-DOS.

N. Kantaris. 64 pages. £2.95.

Order Code BP232

A ready-reference guide for those who need a quick insight into the essential command functions of this operating system, but who don't have the time to learn it fully.

An Introduction to Computer Peripherals

R.A. and J.W. Penfold. 80 pages.

£2.50. Order Code BP170

Covers such items as monitors, printers, disc drives, cassettes, modems, etc, explaining what they are and how to use them with your computer and with each other.

Microprocessing Systems and Circuits

F.A. Wilson. 256 pages. £2.95.

Order Code BP77

A comprehensive guide to the elements of microprocessing systems, covering the fundamental principles behind this important subject.

Introduction to 6800/6802 Microprocessor Systems

R.J. Simpson and T.J. Terrell. 238

pages. £10.95. Order Code NT9

The book covers systems hardware, programming concepts and practical experimental work that will assist in understanding the 6800/6802 microprocessor, with additional information on the 6802D5E evaluation system.

NEW An Introduction to 68000 Assembly Language.

R.A. and J.W. Penfold. 112 pages.

£2.95. Order Code BP184

Covers the fundamentals of writing programs that will vastly increase the speed of 68000 based machines such as the Commodore Amiga, Atari ST range, Apple Macintosh, etc.

Getting the Most from Your Printer

J.W. Penfold. 96 pages. £2.95.

Order Code BP181

How to use the features found on most dot-matrix printers from programs and popular wordprocessors, showing examples of what must be typed to achieve a given effect.

Micro Interfacing Circuits

R.A. Penfold. Two books, each of 112 pages.

Book 1 : £2.25. Order Code BP130.

Book 2 : £2.25. Order Code BP131

Both books include practical circuits and useful background information though pcb layouts are not included. Book 1 mainly covers computer input-output techniques. Book 2 deals primarily with practical application circuits.

NEW An Introduction to 6502 Machine Code.

R.A. and R.W. Penfold. 112 pages.

£2.50. Order Code BP147

Covers the main principles of machine code programming on 6502-based machines such as the Vic-20, Oric-1/Atmos, Electron, BBC and Commodore 64. It assumes no previous knowledge of microprocessors or machine code and gives illustrative programming examples.

NEW A Z-80 Workshop Manual.

E.A. Parr. 192 pages. £3.50.

Order Code BP112

A book for those who already know Basic but wish to explore machine code and assembly language programming on Z80 based computers.

Practical Digital Electronics Handbook

M. Tooley. 208 pages. £6.95.

Order Code PC 104

Nine constructional projects introduce digital circuits, logic gates, timers, microprocessors, memory and interface circuits - an essential book for anyone interested in digital devices.

DATA AND INFORMATION BOOKS

Digital IC Equivalents and Pin Connections

A. Michaels. 320 pages. £5.95.

Order Code BP140

Linear IC Equivalents and Pin Connections

A. Michaels. 256 pages. £5.95.

Order Code BP141

Between them these two books show equivalents and pin connections of a popular user-orientated selection of European, American and Japanese ICs. They also include details of functions, manufacturer and country of origin. The Digital ICs book also quotes details of packaging and families.

Opamps

B. Dance. £6.50.

Order Code NT2

Subtitled 'Their Principles and Applications' this interesting book is written in a simple non-mathematical style and provides a source of practical circuits that use both commonplace and more sophisticated opamps.

Electronic Hobbyists Handbook

R.A. Penfold. 96 pages. £4.95. Order

Code BP233

Provides a source of useful information that the amateur enthusiast is likely to need for day-to-day pursuance of hobby electronics.

Practical Electronics Handbook

I. Sinclair. £7.95.

Order Code NT1

A useful and carefully selected collection of standard circuits, rules-of-thumb and design data for enthusiasts, students and engineers involved in radio, computing and general electronics

Newnes Electronics Pocket Book

I.E. Parr. £6.95.

Order Code NT10

Presents all aspects of modern electronics in a readable and largely non-mathematical style, and is a good source of valuable information for enthusiasts and professional engineers alike.

NEW Key Techniques for Circuit Design

G.C. Loveday. £6.95.

Order Code BM 101

Tackles the problems of designing circuits from scratch, introducing the concept of target specifications, the design sequence, device selection, rules of thumb, and useful equivalent circuits.



GENERAL CONSTRUCTIONAL

NEW Electronic Science Projects.

Owen Bishop. 144 pages. £2.95.

Order Code BP104

A bumper bundle of experimental projects ranging in complexity and including a colour temperature meter, electronic clock, a solid state (led display) scope, an infra-red laser, a fascinating circuit for measuring the earth's electrical field strength, and many more.

Electronic Security Devices

R.A. Penfold. 112 pages. £2.50. BP56

Full of ideas for keeping your valuables safe. The circuits include designs for light, infra-red, ultrasonic, gas, smoke, flood, door and baby sensors.

NEW More Advanced Electronic Security Projects. R.A. Penfold. 112 pages. £2.95. Order Code BP190

Follows on from where BP56 leaves off and describes a number of more up-to-date and sophisticated projects, such as pyro-sensors, infra-red and doppler-shift detection, fibre-optic loops, and many others.

NEW Electronic Projects for Cars and Boats.

R.A. Penfold. 96 pages. £1.95.

Order Code BP94

15 fairly simple projects that can be used with a car and/or boat. Stripboard constructional details are included, as are explanations of the circuit theory.

Power Supply Projects

R.A. Penfold. 96 pages. £2.50.

Order Code BP76

A selection of power supply designs, including simple unregulated, fixed voltage regulated and variable voltage stabilised, ni-cad charger, voltage step-up, and inverter.

More Advanced Power Supply Projects

R.A. Penfold. 96 pages. £2.95.

Order Code BP192

Covers more advanced topics than BP76 and includes precision supplies, switch mode and computer controlled supplies, plus a selection of miscellaneous circuits.

NEW Popular Electronic Circuits.

R.A. Penfold. 160 pages. £2.95.

Order Code BP80

Containing a wide range of circuit designs for experienced constructors who are capable of producing working projects direct from a circuit diagram without specific constructional details.

HOW TO ORDER

State your order code and your name and address clearly. Enclose a cheque, PO or international money order (add 50p postage per book - £1.00 for overseas surface mail), and send to:

PE Book Service
Intra House
 193 Uxbridge Road
 London W12 9RA

Books are normally delivered within 10 days but please allow 28 days for delivery.

READY-MADE P.C. BOARDS

Simplify your project assembly – use a ready-made printed circuit board. All are fully drilled and roller tinned. Just slot in the components as shown in the project texts, and solder them. PCBs are the professional route to project perfection.

MAIL ORDERING

Select the boards you want, and send your order to
PE PCB SERVICE, PRACTICAL ELECTRONICS,
193 UXBRIDGE ROAD, LONDON W12 9RA.

Prices include VAT and postage and packing. Add £2 per board for overseas airmail. Cheques should be crossed and made payable to **Intra Press**.

Quote the project name and PCB Code Number, and **print your name and address in Block Capitals**. Do not send any other correspondence with your order.

TELEPHONE ORDERS (OPEN 24 HOURS)

Use your Access card and phone your order to

0268 289923

clearly stating your name and address, card number, and order details.

All orders receive priority attention, but allow 28 days for delivery in case a PCB is temporarily out of stock.

WE CAN ONLY SUPPLY THE PCBs LISTED HERE

**CHECK LATEST ISSUE FOR
PRICES BEFORE ORDERING**

PHOTOCOPIES OF THE TEXTS MAY BE BOUGHT FROM THE EDITORIAL OFFICE AT £1.00 EACH PART (£1.50 OVERSEAS). P&P INCLUSIVE.

COMPONENTS ARE AVAILABLE FROM ADVERTISERS.

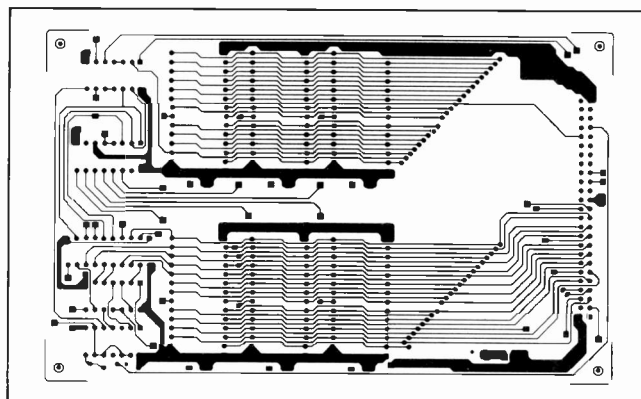

OCT 86		
DRUM SYNTHESISER	121	£7.67
MAINS DELAY TIMER – selectable 15 to 120 mins. Set of 2 PCBs.	122	£7.92
MAINS DIMMER – touch control up to 400W.	123	£3.90
NOV 86		
REMOTE JOYSTICK – infrared computer controller. Set of 2 PCBs.	124	£10.86
BABY ALARM – through-the-mains transceiver.	125	£10.71
DEC 86		
VIDEO ENHANCER – manually adjustable video improvement.	126	£8.76
JAN 87		
VIDEO FADER – simple inexpensive video mixer	127	£4.50
VOICE SCRAMBLER – confidential trans.	128	£8.06
MAR 87		
4 CHANNEL ENHANCER	135	£4.60
LIGHT PEN – uses fibre optics for accuracy	136	£4.10
ULTRASONIC TAPE MEASURE	138	£9.50
APR 87		
VIGILANTE CAR ALARM – keeps cars alert	139	£5.90
INDUCTIVE LOOP TRANSCEIVER – remote control for models:	143/144	£7.80
MAY 87		
BRIGHT FUZZ – Foot operated overdrive	145	£3.90
JUN 87		
AUDIO SIGNAL GENERATOR	146	£10.20
JUL 87		
WORD GENERATOR – 16-bit binary words	147	£13.42
SCOPE STORE oscilloscope add-on data storage	148	£11.94
SEP 87		
SPEECH PROCESSOR – clarifies speech	150	£5.86
GCSE TIMER UNIT – versatile variable delay	151	£5.18
FUNGEN – triple waveform signal generator	152/153	£9.69
LIGHT CONTROLLER – delayed switching	154	£4.64

OCT 87		
TEACHER LOCKER – digital lock control	155	£7.50
POWER SUPPLY – stabilised $\pm 15V$	156	£7.50
GUITAR TO SYNTH – music interface	157A/B	£9.95
NOV 87		
DUAL POWER SUPPLY – GCSE	158	£6.20
MIDI EXPANDER – Music Interface	159	£5.04
DEC 87		
RS 232C TO MIDI	160	£6.43
TEACHER RADIO – GCSE	161	£5.58
JAN 88		
LEGO BUGGY DRIVER	163	£6.42
FEB 88		
TEACHER TALKBACK – GCSE	164	£6.36
DC MOTOR SERVO	165	£7.53
MAR 88		
APPLIANCE TIMER	166A/B	£9.38
TEACHER LIGHTSHOW – GCSE	167A/B	£9.09
LOGIC ANALYSER – Double-sided	168	£20.65
APR 88		
LIGHT METAL EFFECTS	169	£7.10
TEACHER COUNTER	170	£4.95
	171	£4.92
MAY 88		
RF SPEECH PROCESSOR	172	£6.26
JUN 88		
AMSTRAD ROM EXPANSION	173	£10.80
MAINS MODEM	174	£4.27
JULY 88		
VOCALS ELIMINATOR	175	£4.31
AUGUST 88		
SPEAKING CLOCK	176	£16.75
SEPT 88		
BBC MULTIPLEXER	177	£4.50
OCT 88		
METAL DETECTOR	178	£6.50
DEC 88		
PLD PROGRAMMER	179	£9.90
	180	£4.90
PANNING MIXER	181	£7.80
JAN 89		
RUDOLPH'S NOSE	182	£6.25
ANGEL'S HALO	183A/B	£9.40
CANDLE FLICKER	184	£6.25
PULSATING STAR	185A/B	£13.00
RANDOM PUDDING	186	£6.25
MAR 89		
CAMERA SHUTTER TIMER	187	£9.95
APR 89		
PC MULTIPORT	188A/B	£20.55
MAY 89		
KIRLIAN CAMERA	189A/C	£10.50

Free Reader Adverts

*Searching for that elusive component?
Surplus equipment to sell?
Read the rules and fill in the form below to have your free ad published in PE BAZAAR.*

Chain letters: It has come to our attention that chain letters of a speculative financial nature have been sent to individuals who have advertised in PE Bazaar. We recommend that any unsolicited material of this nature should be consigned to the waste bin.

Wanted: IR sensors of any type. Micro FM transmitters and infra red transmitters. For cash or swaps. F. McAllan M, P.O. Box A633 Avondale, Harare, Zimbabwe. Fax: (263) 4731901/2.

Wanted: circuit diagram for Sinclair (Thandar) DM450 multimeter - please! G. O'Brien, 105 Roxborough Road, Harrow HA1 1NT.

PP3 battery clips, five for £1 inc. p & p. Lots available. Send money to Mr. N. Brightmore, 40 Grayling Road, Stourbridge, West Midlands, DY9 7AZ.

Electronic components: small speakers, switches, capacitors, LEDs, large quantities. Very cheap. Private seller. Call Simon on 0843 63495.

Commodore 64C with 1200/75, 300/300 Bell/CCITT multimodem, tape drive, mouse, £250+ software utility cartridge/MC-monitor £350 ono. Owen Bullock, Avoca Lodge, The Chase, Ashingdon, Essex SS4 3JD. Tel: 0702 206308.

Wanted: Atari 1040 STFM. Pref. with software RSP music. Tel: 0909 566695.

Tektronix 545A oscilloscope, type L plug-in unit, type CA plug-in unit. £50 ono. Tel: Mr A. Boyson (0782) 619900.

Organ builders. Hammond console two manuals and pedals, no internal parts £100 ono. Tel: 0344 779741.

Heathkit solid state VOM multimeter model IM-25 £25. Good condition. Phone: Telford (0952) 460618.

Commodore MPS 803 Dot matrix printer plus 500 sheets of paper. Great condition £90. Steven Aspris, 156 Brookscroft Road, Walthamstow, London E17 4JR.

Interested in electronics and penfriendship? Write now if you don't want to miss similar minded friend, Aftab Ahmed Parwaz, 106 Bowyer Road, Alum Rock, Birmingham B8 1ES.

Jupiter ACE wanted, cassettes, hardware, documentation. Contacts with FORTH users. J. Charter, 17 Springwood Close, Chesterfield S41 8BS. Tel: 237555.

Tektronix type 535A oscilloscope for sale. Needs new valves. Tel: 01-393 8511 anytime.

Wanted: service manual for telequipment DM64 oscilloscope. Photocopy accepted, will pay good price. Mr. P. Bridge, 13 Gaer Vale, Newport, Gwent, S. Wales NP9 3HR.

Leak stereo twenty, Variscope preamp (both working). Leak troughline tuner £150 Radford SCA30 Armstrong 526. Tel: 0702 76019.

Relays 40+ 3PCO coil 24v DC 48v AC contacts 5A 250v solder tags and/or socket supplied £2.50 each inc. p&p. R. Stephenson, 7 Cripplegate Lane, Hoghton, Nr. Preston, Lancs PR5 0RR.

Wanted: one Amstrad 40009-A chip for CPC 464. Phone Entil on 0501 23527.

Scopex oscilloscope 14D10 10MHz dual trace as new in original packing with manual £150. Tel: 0707 874245 after 6pm.

PE 'Joanna' electric piano. 5 octave with 3 voices and vibrato. Teak veneer case, in-built pedals. £69. Robin Asher tel: 0602 253916.

Wanted: circuit for 6 valve A.C. mains receiver with 40 coilpack. Circa 1950 P.W. or advertisers project. F. Jackson, 54 Gagewell Drive, Wakefield WF4 6BS.

75m/m scope 10MHz 5mV/div leads and instructions £75 digital multimeter 3.5 digit .5inch display with leads, instructions £25. P.R. Vasey, 117 Hockfield, Harlow, Essex CM18 6QL. Tel: Harlow 36730 anytime.

Akai 4000DS stereo four track tape deck c/w operators/service manuals for sale £120 ono. E.G. Priestley FBIS, 6 Lynden Avenue, Windhill, Shipley, West Yorks BD18 1HF. Tel: 593382.

Digital multimeter, UV exposure unit, multivoltage power supply plus various components. Send sae for list to:- Darren Roberts, 58 Pleasant Street, Hill Top, West Bromwich, W. Midlands B70 0RE.

TDS easycolour 4200 colour terminal plus division MC20 RGB video monitor £50 inc manuals. Tel; Bracknell 427159.

TNG 3114 IC made by Transistoron of USA, (no other info. available). 35 for £3.50. Mr. A. Khan, 73 Park Road, Bolton, BL1 4RQ.

PE synthesiser original superb design. Stand-alone, with partly completed modular expansion unit. Great sound! £69. Tel: Robin Asher 0602 253916.

Hi-fi amplifier, Cambridge P50. Classic design, superb quality 25 watt per channel. Teak veneer case. Bargain £69. Tel: Robin Asher 0602 253916.

UK101 computer, cased with extra 48K memory, sound generator, user ports etc. lotsa software. Bargain £49. Tel: Robin Asher 0602 253916.

Wanted: Ferguson portable VCR model 3V46 and camera model 3C02. Details to: A. Strickland, 21 Mottershead Avenue, Little Lever, Bolton BL3 1QN.

Wanted: Phillips tape recorder rewind motor model N4416 Ref. No. 4322-010-04831W10 anti clockwise 233. K.L. Jones, 10 Hill Grove, Moreton, Merseyside, L46 0SA. Tel: 051-606 9849.

Bruel and Kjaer 2301 level recorder for sale. Offers? 76 Glencoe Road, Bushey, Herts WD2 3DS.

PE BAZAAR

Name & Address			

Please publish the following small ad. FREE in the next available issue. I am not a dealer in electronics or associated equipment. I have read the rules.
Signature.....Date.....

RULES Maximum of 16 words plus address and/or phone no. Private advertisers only (trade or business ads. can be placed in our classified columns). Items related to electronics only. No computer software. PE cannot accept responsibility for the accuracy of ads. or for any transaction arising between readers as a result of a free ad. We reserve the right to refuse advertisements. Each ad. must be posted within one month of cover date. (One month later for overseas readers).
Send this form (or a photocopy of it) to:
PE Bazaar, Practical Electronics, 193 Uxbridge Road, London W12 9RA.

QUALITY... SECURITY SUPPLIES

FOR DIY & TRADE

...AT LOWEST PRICES

SENSORS

- Passive Infra-Red
- Ultrasonic
- Infra-Red Beam

CONTROL UNITS

- Automatic
- Modular
- Lighting
- Timer

ACCESSORIES

- Contacts
- Pressure Pads
- Security Lighting
- Cable Etc. Etc.

CARS & VANS

HOMES & FACTORIES

PRODUCT OF THE MONTH

IR 1470 50' INFRA-RED BEAM SYSTEM

FOR SECURITY, INDUSTRIAL & PHOTOGRAPHIC APPLICATIONS

Starred features

- 12V Operation
- ED Alignment Indicator
- Invisible Modulated Beam
- Easily Installed
- Size Only 82x52x57mm

ONLY £26.61 + VAT

The Security Specialist

RISCOMP LIMITED

Dept. PE3, 51 Poppy Road, Princes Risborough, Bucks. HP17 9DB

Callers by Appointment Office hours Mon - Fri 9am - 5pm

TELEPHONE OR SEND FOR FREE LITERATURE TODAY

(084 44) 6326

MASTERCARD VISA

INTRODUCING THE WORLD'S SMALLEST WEATHER STATION

The amazing weather computer that you can hold in the palm of your hand.

FEATURES

- WIND SPEED
- WIND DIRECTION
- WIND CHILL
- WIND GUST RECORD
- TEMPERATURE
- HIGH/LOW TEMP. RECORD
- RAINFALL (optional)
- TIME OF DAY
- AUTO SCAN
- METRIC / U.S.A.
- EX STOCK DELIVERY
- ONE YEAR WARRANTY

FULL MONEY BACK GUARANTEE

PLEASE ADD VAT AT 15%
POST & PACKING £5.00:

FOR ONLY £99.95

The new **TWR-3 Micro Weather Station** includes a computer, precision wind vane and speed sensor with mounting hardware, and 12 metres of cable.

With the optional, automatic-emptying RG-3 Rain Collector you can even monitor rainfall!

To order call

ICS ELECTRONICS LTD
UNIT V, RUDFORD INDUSTRIAL ESTATE, ARUNDEL, WEST SUSSEX BN18 0BD.
TELEPHONE: 0243 65655

Access VISA

INDEX TO ADVERTISERS

A.C. Electronic	61	Keytronics	36
A.D.M. Electronics Supplies	61	K-Tek	61
Andor Electronics	53,60	London Electronics College	60
Astronomy Now	47	Magenta Electronics	30,31,60
Barrie Electronics	49	Maplin Electronics	OBC
B.K. Electronics	IBC	Mauriton Electronics	62
Biore-Barton Ltd	61	Micro Systems	49
Bull J.	63	National Component Club	34
Cadsoft Systems	62	N.C.A. Designs	62
Cambridge Computer Science Ltd	61	Number One Systems	59
	61	Omni	60
Circuit Distribution	50	Payne Electroprint	62
Classified Ads	60-62	Phonosonics	25
Coles Harding	61	PLS	60
Component Solutions	35	Program Now	62
Cooke International	61	Proto Design	62
Cricklewood Electronics	35	Radio & Telecommunications	
C.R. Supply Co.	61	Correspondence School	60
Deansgate	60	Riscomp	70
Display Electronics	18	RMOS	61
Electrovalue	39	Service Trading	49
Extech	61	Specialist Semiconductors	17
Fraser Electronics	60	Spiretroniks	62
Greenbank Electronics	34	Stewart of Reading	29
Greenwell Electronics	40	Suma Designs	50
Hanney, L.F.	60	Sutronics	61
Hart Electronics	55	Tandy	IFC
High Grade Components	26	Technical Info Services	62
ICS Electronics	70	Technomatic	10,11,60
J.B. Designs	53	Thandar Electronics	55
J.P.G. Electronics	61	T.K. Electronics	45
Kemsoft	29	Ward Electronics	62

PLEASE MENTION PRACTICAL ELECTRONICS WHEN REPLYING TO ADVERTS

OMP POWER AMPLIFIER MODULES-TURNABLES-DIMMERS-LOUDSPEAKERS-19 INCH STEREO RACK AMPLIFIERS

OMP POWER AMPLIFIER MODULES Supplied ready built and tested.

OMP POWER AMPLIFIER MODULES Now enjoy a world-wide reputation for quality, reliability and performance at a realistic price. Four models available to suit the needs of the professional and hobby market - i.e. Industry, Leisure, Instrumental and Hi-Fi etc. When comparing prices, NOTE all models include Toroidal power supply, Integral heat sink, Glass fibre P.C.B. and Drive circuits to power compatible Vu meter. Open and short circuit proof.

THOUSANDS OF MODULES PURCHASED BY PROFESSIONAL USERS



OMP100 Mk 11 Bi-Polar Output power 110 watts R.M.S. into 4 ohms. Frequency Response 15Hz - 30KHz -3dB. T.H.D. 0.01%. S.N.R. -118dB. Sens for Max. output 500mV at 10K. Size 355 x 115x65mm. PRICE £33.99 + £3.00 P&P.



NEW SERIES II MOS-FET MODULES

OMP/MF 100 Mos-Fet Output power 110 watts R.M.S. into 4 ohms. Frequency Response 1Hz - 100KHz -3dB. Damping Factor, >300. Slew Rate 45V uS. T.H.D. Typical 0.002%. Input Sensitivity 500mV. S.N.R. -125dB. Size 300 x 123 x 60mm. PRICE £39.99 + £3.00 P&P.



OMP/MF200 Mos-Fet Output power 200 watts R.M.S. into 4 ohms. Frequency Response 1Hz - 100KHz -3dB. Damping Factor >300. Slew Rate 50V uS. T.H.D. Typical 0.001%. Input Sensitivity 500mV. S.N.R. -130dB. Size 300 x 155 x 100mm. PRICE £62.99 + £3.50 P&P.



OMP/MF300 Mos-Fet Output power 300 watts R.M.S. into 4 ohms. Frequency Response 1Hz - 100KHz -3dB. Damping Factor >300. Slew Rate 60V uS. T.H.D. Typical 0.0008%. Input Sensitivity 500mV. S.N.R. -130dB. Size 330 x 175 x 100mm. PRICE £79.99 + £4.50 P&P.

NOTE - MOS-FET MODULES ARE AVAILABLE IN TWO VERSIONS: STANDARD - INPUT SENS. 500mV BAND WIDTH 100KHz P.E.C. (PROFESSIONAL EQUIPMENT COMPATIBLE) INPUT SENS. 775mV BAND WIDTH 50KHz (ORDER STANDARD OR P.E.C.)

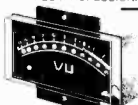

Vu METER Compatible with our four amplifiers detailed above. A very accurate visual display employing 11 L.E.D. diodes (7 green, 4 red) plus an additional on/off indicator. Sophisticated logic control circuits for very fast rise and decay times. Tough moulded plastic case, with tinted acrylic front. Size 84 x 27 x 45mm. PRICE £8.50 - 50p P&P.

LOUDSPEAKERS



LARGE SELECTION OF SPECIALIST LOUDSPEAKERS AVAILABLE, INCLUDING CABINET FITTINGS, SPEAKER GRILLES, CROSS-OVERS AND HIGH POWER, HIGH FREQUENCY BULLETS AND HORNS, LARGE S.A.E. (30p STAMPED) FOR COMPLETE LIST.

MCKENZIE - INSTRUMENTS, P.A., DISCO, ETC.

- ALL MCKENZIE UNITS 8 OHMS IMPEDENCE**
- 8" 100 WATT C8100GPM GEN. PURPOSE LEAD GUITAR, EXCELLENT MID DISCO. RES. FREQ. 80Hz. FREQ. RESP. TO 14KHz. SENS. 99dB. PRICE £28.59 + £2.00 P&P
 - 10" 100 WATT C10100GP GUITAR, VOICE, ORGAN, KEYBOARD DISCO. EXCELLENT MID. RES. FREQ. 70Hz. FREQ. RESP. TO 6KHz. SENS. 100dB. PRICE £34.70 + £2.50 P&P
 - 10" 200 WATT C10200GP GUITAR, KEYBOARD, DISCO. EXCELLENT HIGH POWER MID. RES. FREQ. 45Hz. FREQ. RESP. TO 7KHz. SENS. 103dB. PRICE £47.48 + £2.50 P&P
 - 12" 100 WATT C12100GP HIGH POWER GEN. PURPOSE LEAD GUITAR, DISCO. RES. FREQ. 45Hz. FREQ. RESP. TO 7KHz. SENS. 98dB. PRICE £36.66 + £3.50 P&P
 - 12" 100 WATT C12100TC TWIN CONE) HIGH POWER WIDE RESPONSE, P.A., VOICE, DISCO. RES. FREQ. 45Hz. FREQ. RESP. TO 14KHz. SENS. 100dB. PRICE £37.63 + £3.50 P&P
 - 12" 200 WATT C12200B HIGH POWER BASS, KEYBOARDS, DISCO. P.A. RES. FREQ. 40Hz. FREQ. RESP. TO 7KHz. SENS. 100dB. PRICE £54.17 + £3.50 P&P
 - 12" 300 WATT C12300GP HIGH POWER BASS LEAD GUITAR, KEYBOARDS, DISCO. ETC. RES. FREQ. 45Hz. FREQ. RESP. TO 5KHz. SENS. 100dB. PRICE £85.79 + £3.50 P&P
 - 15" 100 WATT C15100BS BASS GUITAR, LOW FREQUENCY, P.A. DISCO. RES. FREQ. 40Hz. FREQ. RESP. TO 5KHz. SENS. 99dB. PRICE £53.70 + £4.00 P&P
 - 15" 200 WATT C15200BS VERY HIGH POWER BASS. RES. FREQ. 40Hz. FREQ. RESP. TO 4KHz. SENS. 99dB. PRICE £73.26 + £4.00 P&P
 - 15" 250 WATT C15250BS VERY HIGH POWER BASS. RES. FREQ. 40Hz. FREQ. RESP. TO 4KHz. SENS. 99dB. PRICE £80.53 + £4.50 P&P
 - 15" 400 WATT C15400BS VERY HIGH POWER, LOW FREQUENCY BASS. RES. FREQ. 40Hz. FREQ. RESP. TO 4KHz. SENS. 102dB. PRICE £94.12 + £4.50 P&P
 - 18" 400 WATT C18400BS EXTREMELY HIGH POWER, LOW FREQUENCY BASS. RES. FREQ. 27Hz. FREQ. RESP. TO 3KHz. SENS. 99dB. PRICE £167.85 + £5.00 P&P

EARBENDERS - HI-FI, STUDIO, IN-CAR, ETC.

- ALL EARBENDER UNITS 8 OHMS EXCEPT EB8-50 AND EB10-50 DUAL 4 AND 8 OHM BASS, SINGLE CONE, HIGH COMPLIANCE, ROLLED FOAM SURROUND**
- 8" 50 WATT EB8-50 DUAL IMPEDENCE, TAPPED 4 & 8 OHM BASS, HI-FI, IN-CAR. RES. FREQ. 40Hz. FREQ. RESP. TO 7KHz. SENS. 97dB. PRICE £8.90 + £2.00 P&P
 - 10" 50 WATT EB10-50 DUAL IMPEDENCE, TAPPED 4 & 8 OHM BASS, HI-FI, IN-CAR. RES. FREQ. 40Hz. FREQ. RESP. TO 5KHz. SENS. 99dB. PRICE £12.00 + £2.50 P&P
 - 10" 100 WATT EB10-100 BASS, HI-FI, STUDIO. RES. FREQ. 35Hz. FREQ. RESP. TO 3KHz. SENS. 96dB. PRICE £27.50 + £3.50 P&P
 - 12" 60 WATT EB12-60 BASS, HI-FI, STUDIO. RES. FREQ. 28Hz. FREQ. RESP. TO 3KHz. SENS. 92dB. PRICE £21.00 + £3.00 P&P
 - 12" 100 WATT EB12-100 BASS, STUDIO, HI-FI, EXCELLENT DISCO. RES. FREQ. 26Hz. FREQ. RESP. TO 3KHz. SENS. 93dB. PRICE £32.00 + £3.50 P&P
 - FULL RANGE TWIN CONE, HIGH COMPLIANCE, ROLLED SURROUND**
 - 5 1/2" 60 WATT EB5-60TC (TWIN CONE) HI-FI, MULTI-ARRAY DISCO ETC. RES. FREQ. 63Hz. FREQ. RESP. TO 20KHz. SENS. 92dB. PRICE £9.99 + £1.50 P&P
 - 6 1/2" 60 WATT EB6-60TC (TWIN CONE) HI-FI, MULTI-ARRAY DISCO ETC. RES. FREQ. 38Hz. FREQ. RESP. TO 20KHz. SENS. 94dB. PRICE £10.99 + £1.50 P&P
 - 8" 60 WATT EB8-60TC (TWIN CONE) HI-FI, MULTI-ARRAY DISCO ETC. RES. FREQ. 40Hz. FREQ. RESP. TO 18KHz. SENS. 89dB. PRICE £12.99 + £1.50 P&P
 - 10" 60 WATT EB10-60TC (TWIN CONE) HI-FI, MULTI-ARRAY DISCO ETC. RES. FREQ. 35Hz. FREQ. RESP. TO 12KHz. SENS. 86dB. PRICE £16.49 + £2.00 P&P

TRANSMITTER HOBBY KITS

- PROVEN TRANSMITTER DESIGNS INCLUDING GLASS FIBRE PRINTED CIRCUIT BOARD AND HIGH QUALITY COMPONENTS COMPLETE WITH CIRCUIT AND INSTRUCTIONS**
- 3W FM TRANSMITTER** 80-108MHz. VARICAP CONTROLLED PROFESSIONAL PERFORMANCE. RANGE UP TO 3 MILES. SIZE 38 x 123mm. SUPPLY 12V @ 0.5AMP. PRICE £14.49 + £1.00 P&P
 - FM MICRO TRANSMITTER** (BUG) 100-108MHz. VARICAP TUNED COMPLETE WITH VERY SENS. FET MIC. RANGE 100-300m. SIZE 56 x 46mm. SUPPLY 9V BATT. PRICE £8.62 + £1.00 P&P

3 watt FM Transmitter

POSTAL CHARGES PER ORDER £1.00 MINIMUM. OFFICIAL ORDERS WELCOME FROM SCHOOLS, COLLEGES, GOV'T BODIES ETC. PRICES INCLUSIVE OF V.A.T. SALES COUNTER VISA ACCESS ACCEPTED BY POST, PHONE OR FAX.

* PRICES INCLUDE V.A.T. * PROMPT DELIVERIES * FRIENDLY SERVICE * LARGE S.A.E.. 30p STAMPED FOR CURRENT LIST.

OMP VARISPEED TURNTABLE CHASSIS



- * MANUAL ARM
- * STEEL CHASSIS
- * ELECTRONIC SPEED CONTROL 33 & 45
- * VARI PITCH CONTROL
- * HIGH TORQUE SERVO DRIVEN DC MOTOR
- * TRANSIT SCREWS
- * 12 DIE CAST PLATTER
- * NEON STROBE
- * CALIBRATED BAL. WEIGHT
- * REMOVABLE HEAD SHELL
- * CARTRIDGE FIXINGS
- * CUE LEVER
- * POWER 220-240V 50-60Hz
- * 390-305mm
- * SUPPLIED WITH MOUNTING CUT-OUT TEMPLATE

PRICE £59.99 + £3.50 P&P.

OPTIONAL MAGNETIC CARTRIDGES

STANTON AL500
PRICE £16.99 + 50p P&P

GOLDRING G850
PRICE £6.99 + 50p P&P

OMP MOS-FET POWER AMPLIFIERS, HIGH POWER, TWO CHANNEL 19 INCH RACK

THOUSANDS PURCHASED BY PROFESSIONAL USERS



NEW MXF SERIES OF POWER AMPLIFIERS

THREE MODELS:— **MXF200** (100w + 100w)
MXF400 (200w + 200w) **MXF600** (300w + 300w)

All power ratings R.M.S. into 4 ohms.

FEATURES: * Independent power supplies with two Toroidal Transformers * Twin L.E.D. Vu meters * Rotary indexed level controls * Illuminated on/off switch * XLR connectors * Standard 775mV inputs * Open and short circuit proof * Latest Mos-Fets for stress free power delivery into virtually any load * High slew rate * Very low distortion * Aluminium cases * MXF600 Fan Cooled with D.C. Loudspeaker and Thermal Protection

USED THE WORLD OVER IN CLUBS, PUBS, CINEMAS, DISCOS ETC.

SIZES:— MXF 200 W19 x H3 1/2 (2U) x D11
MXF 400 W19 x H5 1/4 (3U) x D12
MXF 600 W19 x H5 1/4 (3U) x D13

MXF200 £171.35

MXF400 £228.85

MXF600 £322.00

SECURICOR DELIVERY £12.00 EACH

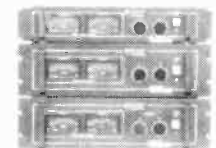

OMP LINNET LOUDSPEAKERS

THE VERY BEST IN QUALITY AND VALUE



MADE ESPECIALLY TO SUIT TODAY'S NEED FOR COMPACTNESS WITH HIGH OUTPUT SOUND LEVELS. FINISHED IN HARDWEARING BLACK VYNIDE WITH PROTECTIVE CORNERS GRILLE AND CARRYING HANDLE INCORPORATES 12 DRIVER PLUS HIGH FREQ. HORN FOR FULL FREQ. RANGE 45Hz-20KHz BOTH MODELS 8 OHM. SIZE H18 x W15 x D12

CHOICE OF TWO MODELS

POWER RATINGS QUOTED IN WATTS RMS FOR EACH CABINET

OMP 12-100 (100W 100dB) PRICE £159.99 PER PAIR

OMP 12-200 (200W 102dB) PRICE £209.99 PER PAIR

SECURICOR DEL. — £12.00 PER PAIR

OMP SLIDE DIMMER 1K WATT & 2.5K WATT

CONTROLS LOADS UP TO 1KW & 2.5KW. SUITABLE FOR RESISTIVE AND INDUCTIVE LOADS. BLACK ANODISED CASE. PREADJUSTED FLUSH MOUNTED THROUGH PANEL CABINET CUT-OUTS. ADVANCED FEATURES INCLUDE—

- * FULL 65mm SLIDE TRAVEL
- * NEON MONITOR INDICATOR
- * FLASH OVERRIDE BUTTON
- * HIGH & LOW I.F.V.F.I. PRESETS
- * FULLY SUPPRESSED TO BS 800

SIZES: 1KW: H128 x W40 x D55mm
2.5KW: H128 x W76 x D79mm

PRICES:— 1K WATT £15.99
2.5K WATT £24.99 + 60p P&P

PIEZO ELECTRIC TWEETERS-MOTOROLA

PIEZO ELECTRIC TWEETERS — MOTOROLA

Join the Piezo revolution. The low dynamic mass (no voice coil) of a Piezo tweeter produces an improved transient response with a lower distortion level than ordinary dynamic tweeters. As a crossover is not required these units can be added to existing speaker systems of up to 100 Watts (more if 2 put in series). FREE EXPLANATORY LEAFLETS SUPPLIED WITH EACH TWEETER.

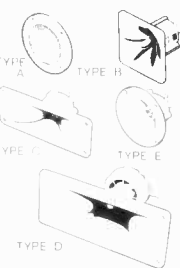

- TYPE 'A'** (KSN2036A) 3" round with protective wire mesh. Ideal for bookshelf and medium sized Hi-Fi speakers. Price £4.90 each + 50p P&P
 - TYPE 'B'** (KSN1005A) 3 1/2" super horn. For general purpose speakers, disco and P.A. systems etc. Price £5.00 each + 50p P&P
 - TYPE 'C'** (KSN6016A) 2" x 5" wide dispersion horn. For quality Hi-Fi systems and quality discos etc. Price £6.99 each + 50p P&P
 - TYPE 'D'** (KSN1025A) 2" x 6" wide dispersion horn. Upper frequency response retained extending down to mid range (2KHz). Suitable for high quality Hi-Fi systems and quality discos. Price £9.99 each + 50p P&P
 - TYPE 'E'** (KSN1038A) 3 1/2" horn tweeter with attractive silver finish trim. Suitable for Hi-Fi monitor systems etc. Price £5.99 each + 50p P&P
- LEVEL CONTROL** Combines on a recessed mounting plate, level control and cabinet input jack socket. 85 x 85mm. Price £3.99 + 50p P&P

STEREO DISCO MIXER

STEREO DISCO MIXER with 2 x 5 band L & R graphic equalisers and twin 10 segment L.E.D. Vu Meters. Many outstanding features 5 Inputs with individual faders providing a useful combination of the following—
3 Turntables (Mag) 3 Mics. 4 Line including CD plus Mic with talk over switch Headphone Monitor Pan Pot L & R Master Output controls Output 775mV. Size 360-280x90mm. Supply 220-240V
Price £134.99 — £4.00 P&P

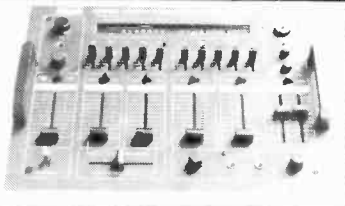

B. K. ELECTRONICS Dept PE

UNIT 5, COMET WAY, SOUTHEND-ON-SEA, ESSEX. SS2 6TR
TEL: 0702-527572 FAX: 0702-420243

Superb Triple-Trace 20MHz Oscilloscope

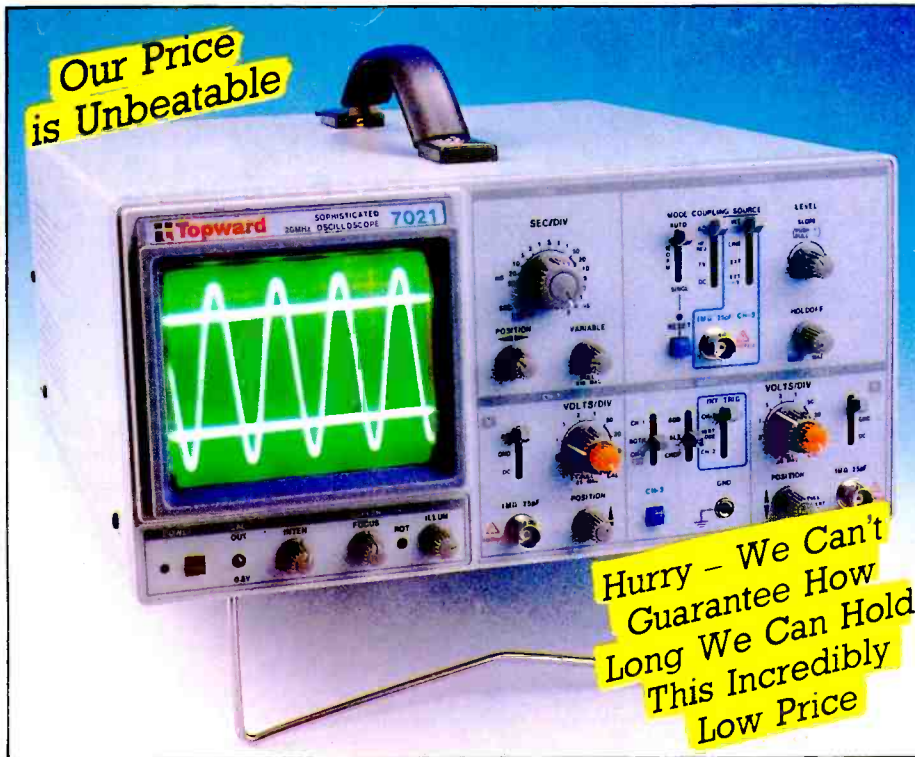

Precision laboratory oscilloscope. 3 Channels - 3 Trace. Sensitive vertical amplifier 1mV/div allows very low level signals to be easily observed. 150mm rectangular CRT has internal graticule to eliminate parallax error. X-Y mode allows Lissajous patterns to be produced and phase shift measured. TV sync separator allows measurement of video signals. 20ns/div sweep rate makes fast signals observable. Algebraic operation allows sum or difference of Channel 1 and 2 to be displayed. Stable triggering of both channels even with different frequencies is easy to achieve. 50mV/div output from Ch 1 available to drive external instrument e.g. frequency counter. A hold-off function permits triggering of complex signals and aperiodic pulse waveforms.

ONLY

£ 287⁴⁹
XJ61R

40MHz Triple-Trace Oscilloscope

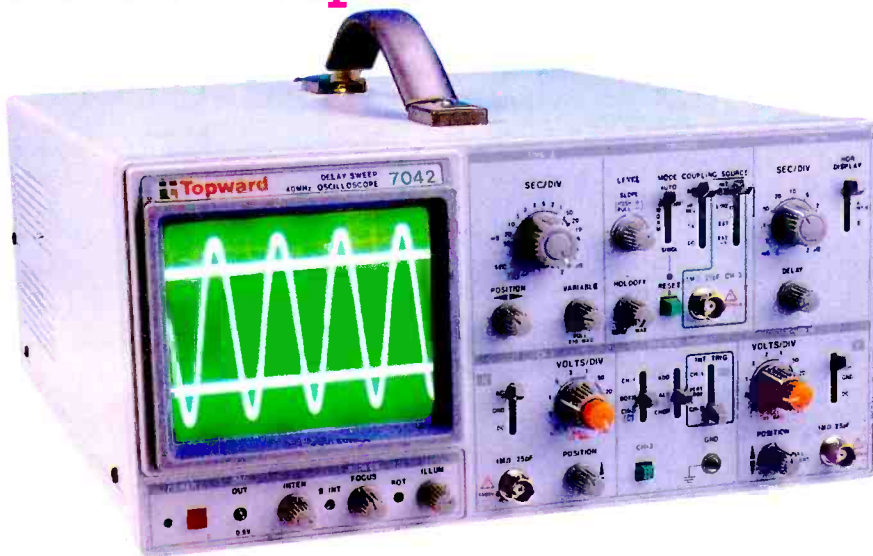

As above, but with 40MHz bandwidth and super bright 12kV tube even at the highest frequencies. This instrument also has a delayed sweep time base to provide magnified waveforms and accurate time interval measurement. Truly superb precision instrument.

**Includes
VAT &
Carriage
As Well!**

ONLY

£ 499⁹⁵
XJ600



Order Coupon Send to P.O. Box 3, Rayleigh, SS6 8LR

Qty.	Description	Code	Price

Add carriage 50p

Name Total

Address

Post Code

I authorise you to debit my Credit Card account for the cost of goods despatched.

Card No.

Access, Amex, Visa delete as required

If ordering by Credit Card please sign

Expiry date of Credit Card

PE

Maplin ELECTRONICS

P.O. Box 3, RAYLEIGH, ESSEX SS6 8LR.



**PHONE BEFORE
5PM FOR SAME
DAY DESPATCH**

0702 554161

ALL PRICES INCLUDE VAT.

All items subject to availability. Subject to availability both items will be on sale in our shops in Birmingham, Bristol, Leeds, London, Manchester, Nottingham, Southampton and Southend-on-Sea.