

PRACTICAL

APRIL 1987 · £1.25

ELECTRONICS

SCIENCE & TECHNOLOGY

**PE VIGILANTE
CAR ALARM**

**PE 30+30
STEREO AMP**

**SWITCH MODE
POWER SUPPLIES**

**INDUCTIVE LOOP
REMOTE CONTROL**

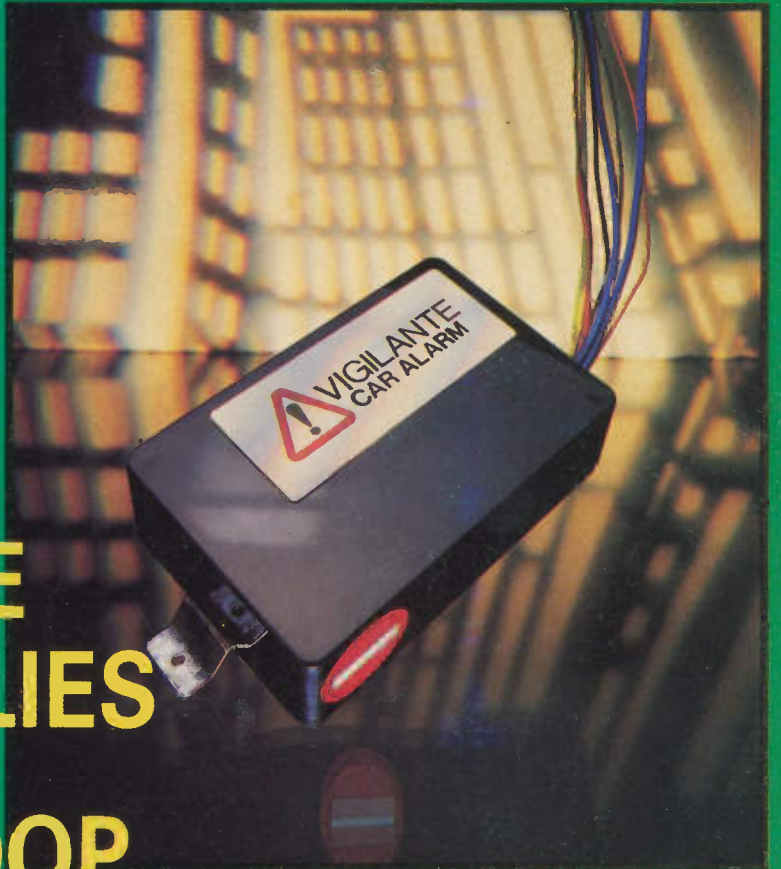

DESIGN – DC MOTORS
TYPES AND FEATURES OF COMMON MOTORS

COMPUTING – DUAL OPTION
EPROM PROGRAMMER FOR THE AMSTRAD

TECHNOLOGY – SENSORS
ESSENTIAL INTERFACE DEVICES EXPLAINED

EXPERIMENTAL ELECTRONICS
AND PRACTICAL APPLICATIONS – ALL IN THIS ISSUE

PLUS:

- ★ SPACEWATCH
- ★ LEADING EDGE
- ★ INDUSTRY NEWS
- ★ CIRCUIT IDEAS
- ★ LOGIC PUZZLE

THE SCIENCE MAGAZINE FOR SERIOUS ELECTRONICS AND COMPUTER ENTHUSIASTS

The ultimate offer from CIL

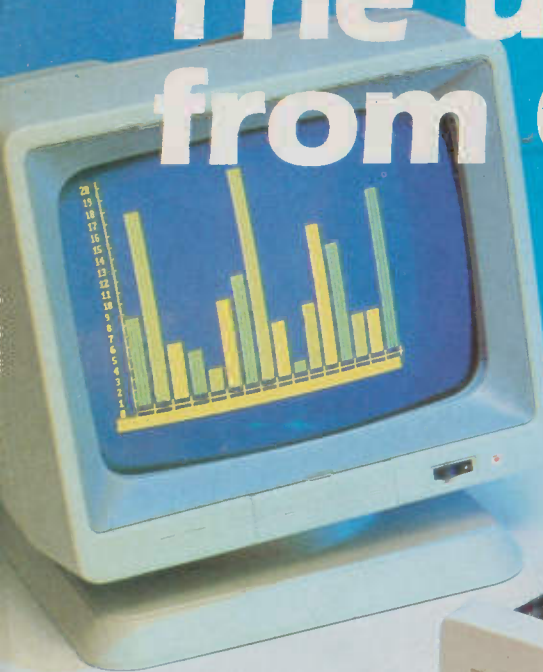

Only £150

Our PC - IEEE
controller card -

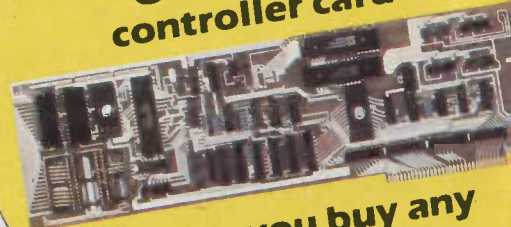

when you buy any
CIL IEEE data
acquisition
instrument



Why use dedicated cards for data acquisition which are noisy **and** use valuable card space? For unbeatable quality and value, buy any CIL interface and you can get our IEEE control card for only £150 extra! It enables you to use **any** other CIL data acquisition IEEE instrument, with the extra advantages of on-board firmware to link with the computer's language, and a watchdog for industrial applications. 32K RAM is available as an optional extra for IEEE data control.

CIL

Microsystems Ltd

Decoy Road,
Worthing, W. Sussex, BN14 8ND

Tel: Worthing (0903) 210626
Telex: 878443 CIL G

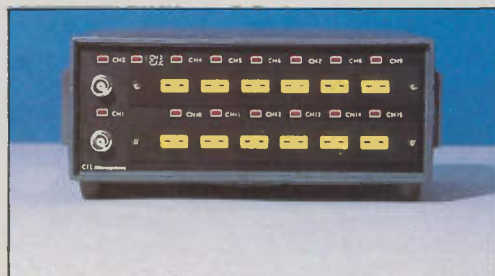

THE CHOICE FOR THE FUTURE

CONSTRUCTIONAL PROJECTS

- PE VIGILANTE CAR ALARM** by Mike Delaney 20
 Keep your car alert to intruders – build a box to fox them!
- SWITCH MODE POWER SUPPLIES** by Robert Penfold 34
 Three practical circuits illustrating the principles discussed in the SMPSU Design feature.
- EXPERIMENTAL ELECTRONICS** by the Prof 12
 Inductive Loops. Ring the changes for your mobiles – remote control them via a cable loop.
- THE PE 30 PLUS 30 PART THREE** by Graham Nalty 48
 Concluding this high quality stereo amplifier design.

SPECIAL FEATURES

- DESIGN – SMPSUS** by Robert Penfold 26
 Familiarity with subject names does not mean that they are understood. This article clarifies one such area – Switch Mode Power Supplies.
- TECHNOLOGY – SENSORS** by the Prof. 40
 For data to be acted upon, it must first be detected. Sensors are a vital link in many control and measurement applications.
- DC MOTORS** by Brian Brooks 52
 During their history, direct current motors have been built and applied in countless different ways. Part two of this feature looks at more of them.

REGULAR FEATURES

- MICROFORUM** by Stephen Burkitt 44
 The Amstrad is ideally suited to Eprom programming control. Here is a choice of two hardware interfaces.
- NEWS AND MARKET PLACE** 4
 News, views and new products from the world of electronics, plus countdown, catalogue casebook, firm contact and chipcount.
- PCB SERVICE** – professional PCBs for PE Projects 60
- TRACK CENTRE** – the PCB track layout pages 32
- BAZAAR** – readers' Have and Have-not marketplace 62
- BINARY CHOP** – a powerful mental logic tester 33
- SPACE WATCH AND THE SKY THIS MONTH**
 by Dr. Patrick Moore OBE 46
- THE LEADING EDGE** by Barry Fox 8
- INDUSTRY NOTEBOOK** by Tom Ivall 57

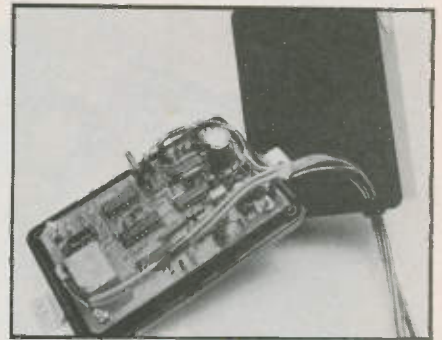

page 20

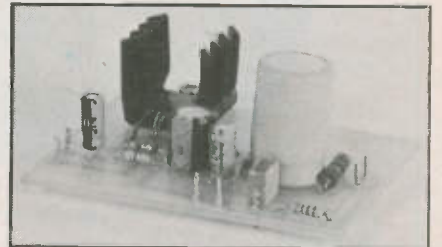

page 34

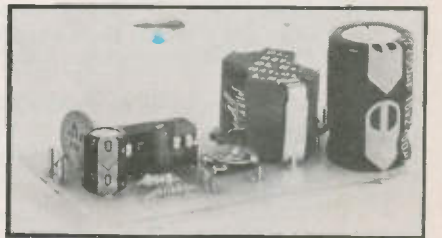

page 12

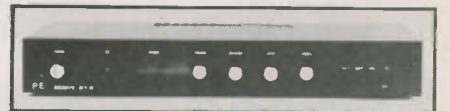

page 48



page 46



THE SCIENCE MAGAZINE FOR SERIOUS ELECTRONICS ENTHUSIASTS

CATALOGUE CASEBOOK



Last month we received the following catalogues and literature:

Eagle International has launched into 1987 with a new look. Their colourful 40 page all-range catalogue also announces some major new products. Eagle International, Unit 5, Royal London Estate, 29/35 North Acton Road, London NW10 6PE.

Fane, the manufacturers of professional audio components, high power and heavy duty speakers, have sent a list of over 20 new products for 1987 that will be introduced at the Frankfurt Fair. Fane Acoustics Ltd., 286 Bradford Road, Batley, West Yorkshire, WF17 5PW.

Flight Electronics' 5th edition 1986/87 colour illustrated catalogue of micro electronic systems and instrumentation, with particular emphasis on training systems. Flight Electronics Ltd., Flight House, Ascupart Street, Southampton, Hants, SO1 1LU.

Greenweld's Kit Cat features top quality kits by Velleman, Pantech and Greenweld. The catalogue is liberally illustrated with photographs and drawings. Greenweld Electronics Ltd., 443 Millbrook Road, Southampton, SO1 0HX.

The **Inmac** 140 page January 1987 catalogue is a computer users ideas book of instant mini/micro computer accessories and cables - a remarkable product source. Inmac (UK) Ltd., 16 Silver Road, London W12 7SG.

Instrument Rentals' 100 page 1987 catalogue of electronic test and measurement equipment includes more than 1000 different manufacturer models. It also contains sections on computers, industrial and survey equipment for hire and second user sale. Instrument Rentals, Dorcan House, Meadfield Road, Langley, Slough, SL3 8AL.

MBS claim that their telephone number is the only one you will ever need. If you are after computer accessories, their Jan-Feb 87 catalogue is worth studying. MBS, Maxted Road, Hemel Hempstead, Herts, HP2 7BR.

Phonosonics' current catalogue contains over 70 kits for music, sound effects, and computer projects. Additionally Geiger counters in both kit and ready built form are prominently emphasised. Phonosonics, 8 Finucane Drive, Orpington, Kent, BR5 4PE.

Technomatic's new extensive list of computers, printers, modems, disc drives, and a multitude of electronic components, is vital source material for any quality-seeking electronics constructor or computer user. Technomatic Ltd., 305 Edgware Road, London W2.

WHAT'S NEW

Small Detector

A new passive infra-red intruder detector has been announced by Riscomp Limited. Called the RP33, it operates by sensing an intruder's body heat within the protected area. The detector, which uses a Fresnel lens, provides volumetric coverage through an 85 degree angle, with twenty four zones over ranges of twelve metres. The miniature size of 80 x 60 x 40mm permits it to be easily installed on any flat surface or corner location, with vertical adjustment of the detection pattern over a 10 degree range to achieve the most effective coverage.

A further aid to installation is a switchable walk test indicator, which provides a visual indication of the effective range. Using a 15mA operating current from a conventional 12V supply, the unit is suitable for use in most security installations. It costs £23.95 plus VAT. A leaflet is available from Riscomp with full installation instructions.

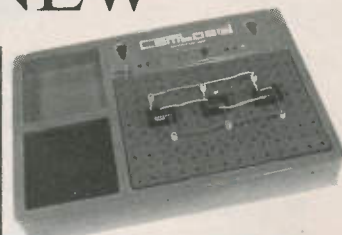

sensitive components before connection. The boards can be mounted at 90 degrees or 180 degrees to the user for easy access, and the board can be stored upside-down in its tray if necessary to protect components mounted on it.

The basic unit can in addition be supplied in packs with one, three or seven 16-pin i.c. sockets.

One advantage of the plugboard arrangement over traditional stripboards is that this gives the space and flexibility to translate a design straight from schematic to working prototype without the necessity for designing around copper strip connections. Camboard also boasts a different contact arrangement from most breadboards. Normal breadboard clips make contact with the thin edge of i.c. pins, which are narrow, and roughened by the stamping process. Camboard's sockets make contact with the broad, smooth edge of the i.c. pins, increasing the area of contact and minimising wear on the contact plating.

Circuits can be built up on one Camboard, or over a number of separate boards.

The price for the basic unit is £4.36, excluding VAT but including carriage. Units with one, three and seven i.c. socket packs cost £4.79, £5.18 and £6.92 respectively.



Chip Board

CAMBOARD of Cambridge are producing a range of solderless breadboard modules designed to overcome some of the space and connection problems associated with using breadboards for prototyping and testing circuits.

The basic breadboard unit provides a removable plugboard grid of ten by fourteen connecting holes in a specially made base tray, with a power busbar, power connections and extra mounting holes for discrete components integrated into the tray. There are also two sensibly-sized component holders, one fitted with conductive foam to protect i.c.s. and other static-

P.E. Kit

AUDIOKITS, supplier of specially graded components to hifi constructors, is introducing two new audio amplifier kits during the first half of 1987.

The first, well known now to readers of Practical Electronics, is the PE 30 + 30 slimline integrated hifi amplifier, which includes tone controls, two tape recorder connections with dubbing in both directions, and a switched MC input. The complete kit, which uses very high quality components, costs £140. A kit for the same amplifier using the very best components which can be fitted to the same board will be available later at around £330 - £350.

Later this year the Everyday Electronics Apex amp will be available in kit form. No further details are available at present.

Among the unusual or specialised components offered by Audiokits in 1987 are bulk foil resistors, manufactured to the highest standards of accuracy with low internal capacitance and inductance, and a very low temperature coefficient of 4ppm/degrees C or better, from zero to sixty degrees. Extended foil capacitors are made in Britain for high precision telecommunications filter circuits: a range selected for sonic qualities is being made available, including 200pF and 470pF capacitors for MM cartridge matching, and 8nF for MC cartridge matching, as well as higher values up to 250nF.

For constructors who have problems with mechanical noise in mains transformers, Audiokits offers the same specially manufactured low noise transformers that it uses in its own kits.

To help hifi builders who to use individual components not specified in original parts lists, Audiokits has issued a set of parts price lists for various magazine amplifier projects. The next plan is to produce component application notes along the same lines, selling at between 50p and £5.00.

Audiokits were at the Hifi '87 show at the Holiday Inn in Brighton on 20-22 February, providing high quality components and technical information for their customers.

20kHz. A direct reading d.c. voltmeter with 0-10 v.d.c and 0-20kHz scales is built in. The controls (shown in the photograph) include a a.c./d.c. input select, amp gain, Y position, mode select, sweep variable coarse and fine, range select and internal battery check.

The very small size and modest price of the Scope-Probe has been achieved by the use of a ten by fourteen l.e.d. matrix in place of a c.r.t or l.c.d. Lefax believe that the handy, portable 'scope will be beneficial to lab based users as well as to those working in repair and maintenance in the field.

The Scope-Probe will be available by mail order from Lefax, priced £89.95 exclusive of VAT, postage and packing.

Water Watcher

BATTELLE of Ohio has developed a wristwatch-sized 'underwater decompression computer' for undersea divers. The function of the computer is to assess the length of time and depths of water which have been dived, and to tell the diver, by means of a visual readout, when and how far it is safe to ascend through the water.

Too fast an ascent through a considerable depth of water leads to aeroembolism, a condition where nitrogen, forced into the bloodstream by the greater pressure of the surrounding water, passes out of



aluminium oxide substrate one and a half inches square. The device can be used either with oxygen and helium or oxygen and nitrogen breathing mixtures, and can be used, it is said, to monitor gas pressure status under some circumstances. In addition, plug in personal computer modules can be attached to store and read out dive histories.

Battelle is working to introduce the decompression computer into the commercial market, and would like to hear from individuals or organisations interested in working with them on this product. Information can be obtained from Battelle's London Office, from Renate Seibrasse, Operations Manager, Battelle Institute Ltd., 15 Hanover Square, London W1.

Digital Desk

A totally self contained digital electronics workstation for those studying advanced electronics, or working on the prototyping of circuits, is being marketed by Flight Electronics of Southampton. The FLT-102 Digital Training Laboratory, which resembles nothing so much as a compact multi-channel mixing desk, has built into it multi-rail variable d.c. supply, a four-range digital voltmeter, function generator, seven segment displays, logic switches, pulse switches and logic indicators. Everything, in short, that you wish you had on your trusty low cost hand held multimeter. The difference is that the FLT-102 costs £250, and is more likely to appeal to teaching establishments and commercial

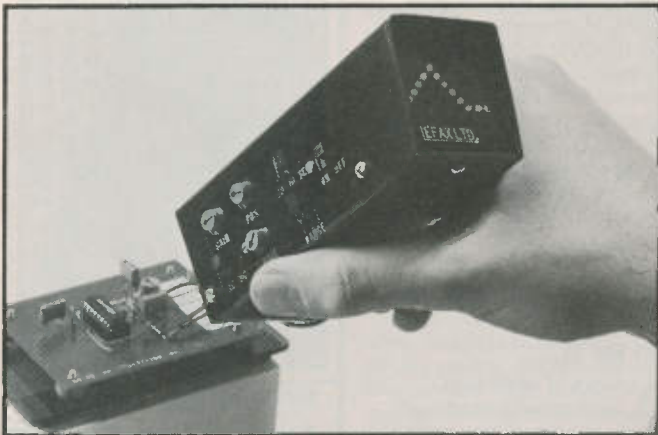

Scope In Hand

LEFAX Ltd. have developed a tiny hand held oscilloscope with a detachable probe tip. The size of the Lefax Scope-probe is only 46 by 46 by 120mm, and it can be used either in a similar way to a logic probe, or as a bench instrument with standard 'scope leads'. An internal alkaline battery allows around twelve hours continuous use before it needs charging.

The 'scope has five frequency ranges, and the manufacturers say that despite the small screen, which inevitably has a restricted resolution, it can display most waveforms between 10Hz and

the bloodstream in bubbles as the pressure is released. Known as 'the bends', aeroembolism can be fatal, so it is of vital importance that a diver does not rise from deep water too quickly after a period of submergence.

The wrist computer, says Battelle, will allow the diver to move independently and safely in depths up to 300 feet, keeping track of how much time has been spent at a particular depth, and how much time should elapse before a further ascent can be made.

The battery-operated computer uses 1mA to power its i.c.s., which are printed on

CHIP COUNT

This month's list of new component details received.

- 601-TYPE - DIL microfilters with good RFI screening. (3).
- IMS1630 - VHS 8K x 8S RAM, requires no external clocks. (2).
- MVA1000 - 75 Ohm fixed gain (12dB) 0-10MHz video amp. (3).
- TP1481 - HV op-amp for ±15v to ±75v supplies, 80mA. (3).
- TP1493 - Fast setting (120 nsecs) wideband (40MHz) op-amp. (3).
- TP1648 - HV op-amp for ±10v to ±50v supplies, 10A. (3).
- TP4192 - 12-bit A/D fast (500nS) precision converter. (1).
- UMHL/UMCL - Microfilters for 7th/9th order low pass. (3).
- VS618 - Lows pass video filters for analog TV improvement. (3).
- WS57C191/291 - 2K x 8 CMOS RPPROM. (4).
- WS57C256F - 32K x 8 CMOS EPROM. (4).
- WS57C43 - 4K x 8 CMOS RPPROM. (4).
- WS57C49 - 8K x 8 CMOS RPPROM. (4).
- WS57C64F - 8K x 8 CMOS EPROM. (4).

Manufacturers, and contact telephone numbers for further details. (1) Teledyne Philbrick, 01-902-1191. (2) Rapid Silicon, 0494-442266. (3) Matthey Electronics, 01-902-1191. (4) Rastra Electronics, 01-748-3143.

laboratories than all but the most dedicated of private students.

The built in regulated d.c. power supply is fully short circuit protected, with ranges of +5V/1A, $\pm 5V/0.5V$, and 0 to $\pm 15V/0.3A$. The function generator provides 1Hz to 100kHz continuously, variable over five decade ranges. The waveform outputs available peak to peak are 0 - $\pm 5V$ sine wave, 0 - \pm triangle wave and 0 - $\pm 5V$ square wave. The digital voltmeter provides four ranges from 199.99mV to 199.99V Fsd. A pulse button generates a pulse of 10 μ s.

A thirty day evaluation period for the unit can be arranged with Flight Electronics. The FLT-102 looks like a very well designed and compact unit with considerable versatility for the

money. As well as teaching establishments, businesses with small electronics workshops doing limited amounts of design and development, particularly in digital, may find the unit worth looking into.

Control By Phone

A MPLICON Liveline Ltd. is a new company within the Amplicon Electronics group, formed to market a family of industrial measurement, data acquisition and control instruments. The company believe that they are the first British electronics company to provide customers with a British Telecom Linkline number: customers anywhere in the UK can make a charge-free call on 0800 525 335 for direct access to the sales desk.

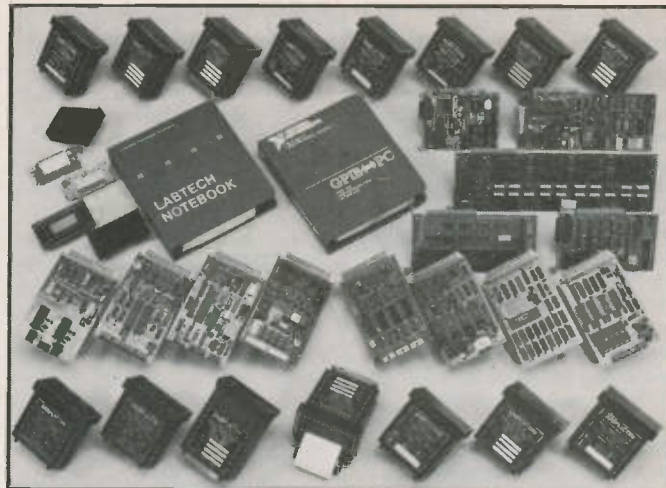

Liveline have their design, manufacturing and marketing facilities all on one site, and expect to be able to set a high standard of customer service, technical documentation and value. Direct keyboard entry on the sales desk, using an IBM System 36 computer, allows despatch orders to be produced quickly, so that stock orders received up to 5pm can be despatched the same day.

The company's main product lines are digital panel instrumentation (meters, counters, printers etc.), board level products for the IBN PC (D to a and A to D conversion, relays non volatile bubble memory, programmable TTL I/O, thermocouple amplification, logic analyser, EPROM programmer) and STE bus (P1000) products (processor, memory, battery backed clock, disc controller a.d.c., OS9 operating system, parallel and serial I/O). The units allow users to specify economical systems for data acquisition and control from the very simple to the very complex.

I/O For PC

A series of multi-slots motherboard which will accept a range of standard I/O function cards, marketed by Electronic & Computer Workshop Ltd., is now available in an intelligent RS232 interfaced version for IBM PCs and compatibles.

Designated the K2612 for PCs, I/O system includes an eight channel analogue multiplexer, A to D and D to A conversion, a Centronics printer port, eight channel logic input, real time clock and a general purpose output card with a choice of relay and triac outputs.

Also included is a breadboard plug-in to allow more experimental users to develop their own interfacing projects.

Digital Meter

A B European Marketing have added the DM2000 digital multimeter to their instrument range. Costing around £31.95, excluding VAT and carriage, the meter handles current up to 10A in manual mode (below 10A the device is fused), and voltage to 1000V and resistance up to 2 megohms in auto and manual modes; audible and visual continuity check, diode test, hold function, and high/low impedance facility are featured. The meter comes complete with one metre test leads, a 9V battery and instructions. Case and croc clips are optional extras.



No-Smoke Detector

PHOTAIN Controls Ltd. is marketing a new ionisation smoke detector which can detect 'fallout' from a fire before visible smoke is produced and before a discernable rise in temperature. Selling at £24.00 plus VAT, the unit, designated ISD-P, is compatible with most types of 24V d.c., two wire, normally open fire sensor loop circuits, and up to fifty detectors can be connected to each zone.

The smoke detector was designed, says Photain, for high stability and reliability without sacrificing sensitivity, with the aim of reducing false alarms while maintaining the detector's effectiveness. This was achieved

COUNTDOWN

If you are organising any electrical, computing, electronic, radio or scientific event, big or small, drop us a line. We shall be glad to include it here. Address details to COUNTDOWN, Practical Electronics, 16 Garway Road, Bayswater, London W2 4NH.

PLEASE NOTE: Some of the exhibitions and events mentioned here are trade only or may be restricted to certain categories of visitor. Also please check dates, times and any other relevant details with the organisers before setting out as we cannot guarantee the accuracy of the information presented here.

IEEIE - Wind Power, 11th March 7.30pm, White Horse Hotel, Dorking, Surrey. 01-836-3357.

IEEIE - Mobile Communications, 12th March 6.00pm, Lecture Room B15, Mountbatten Building, Meriott-Watt University, Grassmarket, Edinburgh. 01-836-3357.

IEEIE - Expert Systems, 19th March 6.30pm, Room 6.12, Queens University of Belfast. 01-868-3357.

Southcon '87, March 24th-26th, Atlanta, Georgia, USA. 0101-212-421-6816.

Cadcam '87, March 24th-26th, Metropole Hotel, National Exhibition Centre, Birmingham. 01-608-1161.

Internecon Production Show and Conference, March 24th-26th, National Exhibition Centre, Birmingham. 0792-792792.

Electronic Printing and Publishing, March 24th-27th, Olympia, London. 01-647-1001.

IEEIE - Hotel, 26th March 8.00pm, Sir Alan Cobham Lounge, Terminal Building, Hurn Airport. 01-868-3357.

Drives '87 Seminar, 3rd April, Lincoln College of Technology. 0522-30641.

Components Fair, 5th April, Pontefract and District Amateur Radio Society, Carleton Community Centre, Carleton, Pontefract. 0977-43101.

Saturn Workshops, 6th-10th April, several residential computer courses, Ludgrove Hall, near Cockfosters tube station, London. 0969-50449.

Laboratory Manchester, 8th-9th April, New Century Hall, Manchester. 0799-26699.

IOA - Acoustics '87, 13th-16th April, Management Centre, Portsmouth Polytechnic. 031-225-2143.

Homvention '87, April 24th-26th, Dayton, Ohio, USA. 0101-603-878-1441.

Electronic Data Interchange Conference, April 28th-29th, The Barbican Centre, London. 01-868-4466.

British Electronics Week '87, April 28th-30th, (incorporating All Electronics/ECIF show, Automatic Test Equipment, Circuit Technology, Communications), Olympia, London. 0799-26699.

Books

William Heinemann have now published the fifth edition of the popular Newnes Electronics Pocket Book by E.A. Parr, priced £8.95. The pocket book, which 'covers all aspects of electronics in a highly readable and non-mathematical form' has been completely revised and updated, with a new chapter on computing, op-amp applications and digital circuit design. Communications and computing have a heavy emphasis in the new edition, which hopes to mirror the increasing emphasis on information technology in the electronics industries, work and (gradually) home environments. The information in the Newnes Electronics Pocket Book is of interest to amateurs, and provides a good ready reference book for professional engineers.

Taking up the theme of satellite television again, J. Vincent Technical Book have added The Ku-Band Satellite TV, Theory Installation and Repair manual to its recently instituted list of publications for sat-TV enthusiasts.

The manual is said to be a comprehensive guide to the installation and adjustment of domestic satellite dishes, with clear and concise text and easy-to-understand illustrations. Also included is information on site surveying, cable television, the descrambling of satellite transmissions and tracking and establishing links with satellites around the world. The book is already on sale in the USA. The UK price is £23, including post and packing and it is also being sold through The Modern Book Shop in London.



by including a fully encased printed circuit which has a high level of protection against electrical interference and line transients. High level immunity to air currents has also been incorporated in the design.

The detector is available with a base to which other types of detectors can be connected without need for any wiring changes.

fibres is coming down, and they allow great flexibility in routing and altering services, especially where there is a large concentration of customer lines.

The current installation work is being carried on from Kings's Cross in the north to Elephant and Castle south of the Thames, and from Covent Garden just west of the City of London to Wapping in the east. Following this, the local fibre connections will be carried out to the rest of London, including the fast developing dockland sites, and the rest of Britain. Around 100 Dealerinterlink users will be the first to use the new network in spring 1987.

Dealerinterlink was set up by BT as part of their support for the Big Bang computerisation of the City. Customers rent groups of circuits connected to a central point. In this way private speech links can be set up with fellow members within 24 hours.

Other services planned include telex, packed switched data lines, private circuits, KiloStream and MegaStream. The optical fibre lines will be able to connect with the public telephone network.

In the local networks, Telecom will use fibres carrying transmission of 2M bits per second (the equivalent of 30 telephone channels) to 140M bits per second. The City network will start out with transmission rates of either 8M or 34M bits per second. The single mode fibre used provides virtually limitless bandwidth for future services, which, it is hoped, will forestall the need for new cable installations.

Most of the hardware is being made in the UK by GEC, Plessey, BICC and TCL. Tenders for the next phase of the programme are now being considered.

Tasteful Insulators!

INSULATOR manufacturers Thermalloy have produced an electrical insulating material which is highly conductive to heat. Called Thermalsil, the material is composed of a silicone elastomer binder with a heat conductive filler, reinforced with glass cloth. The material is flexible and resists tearing or cutting by sharp edges or burns on adjacent components, but does not need thermal grease to

effect the heat transfer. Two varieties are now being made available: Thermalsil II, which is .009in thick and blue grey, and Thermalsil III, which is .006in thick and green-grey. This, say Thermalloy, is 'the thinnest possible matrix for enhanced thermal resistance'. The material comes in standard semiconductor TO-package and washer shapes, and in rolls, with or without an adhesive backing, from MCP.

New optical network

British Telecom is currently working on a \$50M optical fibre network linking up their customers in the City of London. This is the first stage in a major programme to install the most advanced type of single mode optical fibre into business communications, and BT are expecting to install more than 60,000km of fibre in the next twelve months - enough to go twice round the equator.

The advantage of the new system is that BT's customers will be able to send all their services through a single 'pipeline', with better transmission quality and greater flexibility than allowed by conventional cable communications. Telecom say that these installations into business premises are just part of a billion pound per annum project to update the telecommunications network fully. Modernisations of the trunk network is advanced, and £40,000,000 is budgetted for bringing in local digital exchanges this year.

Optical fibre cable is already standard for the trunk and junction networks, but is new to local networks and customer premises. The price of optical

FIRM CONTACT

Addresses of this month's news items (excepting those which already have addresses included in the text) to be added to addresses of regular advertisers in FIRM CONTACT

Riscomp Ltd., 51 Poppy Road, Princes Risborough, Bucks HP17 9DB.

Camboard, Unit 16, Barnwell Business Park, Barnwell Road, Cambridge CB5 8UZ.

Lefax Ltd., Unit 6, Genesis Business Centre, Redkirk Way, Horsham, W. Sussex RH13 5QH.

Electronic & Computer Workshop Ltd., 171 Broomfield Road, Chelmsford, Essex CM1 1RY.

Audiokits Precision Components, 6 Mill Close, Borrowash, Derby DE7 3GU.

Flight Electronics Ltd., Ascupart St., Southampton SO1 1LU.

Amplicon Liveline Ltd., Centenary Industrial Estate, Brighton, E. Sussex BN2 4AW.

AB European Marketing, Wharfedale Road, Pentwyn, Cardiff CF2 7HB.

J. Vincent Technical Books, 24 River Gardens, Purley, Reading RG8 8BX. Tel. (0734) 414468.

William Heinemann Ltd., 10 Upper Grosvenor Street, London W1X 9PA.

MCP Electronics Ltd., 26-32 Rosemont Road, Alperton, Wembley, Middx. HA0 4QY.

THE LEADING EDGE

BY BARRY FOX



The vice-president of Texas Instruments predicts a complete change of approach in i.c. architecture in the next decade.

TEXAS Instruments was in at the beginning of the transistor age, marketing the first silicon device in 1954. Over recent years Texas has pulled out of the cut-throat market for low cost computers and taken a hammering from the Japanese. Now Texas says it will beat the Japanese electronics industry to the market with a 4 megabit memory chip.

George Heilmeier, who is vice-president of TI and in charge of all its research and development, was in London recently and put the last thirty years in perspective. Heilmeier's remarks came soon after a speech by Alec Broers, Professor of Electrical Engineering at Cambridge University. Broers said Britain was several years behind the US and Japan in chip technology and that the UK should get out of chip manufacture and concentrate on state-of-the-art research and design.

Since 1959, when the first integrated circuits were made, the size of individual components on the chip – or 'feature size' – has reduced by 11% per year. There is now a hundredfold increase per decade in the number of devices which can be crammed into a square centimetre chip area. "If the same thing had happened with cars" says Heilmeier "a Rolls Royce would now cost \$3, run 3 million miles on a gallon, have the power of the QE2 and be so small that you could get six on the head of a pin".

Heilmeier believes that chip development has now reached a crucial stage. There is no point in simply continuing to put smaller devices closer together on a single chip. Since the turn of the 80s the industry has been ruling circuit lines on chips with a spacing of less than one micrometre or micron.

"That has separated the men from the boys" he says "Now we have different problems. The connections between the devices dictate the speed of operation. The time taken by the electrons to move round the chip becomes a significant factor. So does interference and interaction between individual parts of the circuit".

"There is no fundamental physical barrier to making conventional chips with a line spacing of less than 0.1 micron. You can work down to around

0.6 microns with ultraviolet light and photo lithography. Below that you have to use electron beams. We can go to 0.1 microns lines spacing in the laboratory – but frankly it's just not interesting because the isolation and interconnect problems become too real".

"For solid state devices the real limit will in practice be between 0.3 and 0.5 microns. If the limits of the device don't get you, the limits at system level will. Something is going to have to happen to push the industry beyond the 0.3 micrometre barrier".

"When? Probably post 1995".

Echoing Professor Broers' remarks (which were given, incidentally, to academics at a Texas Open Day in the UK earlier in the year) Heilmeier warns:

"It is becoming increasingly difficult for small companies to operate in this business. They can design architecture and write software but not manufacture the chips".

The search is now on for new ways of using silicon, and new materials to use instead of silicon. Today's state of the art is a 1 megabit D-RAM (dynamic random access memory) with 1 micron circuit lines. Most of the large Japanese electronics companies say they too have developed 4 Mbit DRAMs. Texas claims a lead with prototype 4 megabit DRAMs made with a 3-dimensional CMOS technique. The chip devices, capacitors and transistors, are sunk into a trench in the silicon and stood upright. This improves isolation and increases packing density. The 4 Mbit D-RAM has 8.4 million components on a 1 square centimetre chip, with 1 micron line spacing.

Heilmeier believes that gallium arsenide material is the best bet for the future. Electrons move much faster through it than silicon. The snag is that GaAs is expensive, brittle and very difficult to work with. TI is now experimenting with devices (1K SRAM) made from hybrid material, a thin layer of gallium arsenide grown on a silicon base.

Why bother with such a low capacity device? "They are blindingly fast" says Heilmeier. "Also GaAs uses much less power than silicon. but you only have

to look at it and it shatters.

Heilmeier is not very enthusiastic about today's vox pop talk of biochips, made from materials like chlorophyll.

"Biological materials never make good transistors, they are too slow. But there is the advantage that individual defects on the chip don't matter. Storage in non-localized".

Biochips work like a hologram – if one piece of the memory is missing, the rest of the memory still holds the same information.

"But remember", adds Heilmeier "that for memory devices, moving optical media – like compact disc – offer much higher density than solid state systems".

Heilmeier has the answer to the obvious question – what are we going to do with all this computing and memory power?

"We need it for the interface between humans and computers. The research team at Xerox who started off trying to make computers more friendly were handicapped because they were too early. There wasn't the technology available at the right price. Companies like Apple made the Mac. Software is now the limiting factor".

"For speech understanding or image understanding you need a very powerful interface – for instance to use a camera and computer to recognise an object in an environment, irrespective of its position. In a browsing database we want to be able to tell the system what to do, not have to tell it how to do it. Vision technology is just aching for parallel processing. Physically stitching many processors together is the easy part. but it's not enough. It's like putting many people on the same project – it takes time for them to communicate with each other. The key is breaking down the problem into the many parts that can be solved by parallel processing and the few parts that need serial processing. You need to extract the parallelism from the problem".

Obviously the Japanese think the same way. Matsushita recently announced the "world's fastest realtime image processor", it is an image sensor that can be paralleled to give a robot sight.

PE SCIENCE
AND
TECHNOLOGY

VOLUME 24 No. 4
APRIL 1987

ISSN 0032 - 6372

Editor:

John Becker

Sub-Editor:

Helen Armstrong

Personal Assistant:

Karen Poole

Advertisement Sales:

Ian Forbes, Alun Thomas,

Mike Thorburn

Publisher:

Angelo Zgorelec

PE Services

Practical Electronics offers a wide range of services to readers including: p.c.b.s, books, subscriptions, back numbers, and software listings. However, due to increased administration costs we can no longer provide photocopies of articles over five years old.

Readers' Enquiries

All editorial correspondence should be addressed to the editor and any letters requiring a reply should be accompanied by a stamped addressed envelope. Please address editorial correspondence to: Practical Electronics, 16 Garway Rd., London W2 4NH. Tel. 01-221 5422

We regret that lengthy technical enquiries cannot be answered over the phone.

Advertisements

All correspondence relating to advertisements, including classified ads, should be addressed to: The advertisement manager, Practical Electronics.

PE EDITORIAL TEL. 01-221 5422
ADVERTISEMENT DEPT.
TEL. 01-434 0689

ELECTRONICS IS FASCINATING

REGULAR readers will be aware of my longstanding association with PE and of my enthusiasm for all matters electronic, which has I hope, been reflected in my constructional articles. My new appointment to the Editorial chair now offers even wider scope for my endeavours to encourage you all to share this enthusiasm.

From an initial childhood interest sparked off by finding that fuses could be blown, curiosity in electronics was further developed through messing around with old television sets, often bought from junk heaps for the sake of the parts. During several years as a film editor, the hobby grew into an acute passion, and every electronics magazine available was hastily acquired. I remember my pleasure when reading the first issue of PE - those pages were bliss to me, opening up new areas of previously uncharted experimentation. Eventually it was inescapable that I should turn professional and I began by contributing my own constructional projects to PE. The encouragement I was shown by Fred Bennett and Mike Kenward in their days as editors of PE was invaluable.

Through the expertise and understanding of its editors, PE has established a long tradition of excellent constructional projects and informative articles. These reflect all aspects of electronics and associated disciplines, with special emphasis on technological trends, and the importance of education in implementing them. I shall maintain this tradition, and broaden its horizons.

Much of modern technology heavily depends on computer circuitry in its various forms. In common with other authors, I have recently been showing in my projects how computers can be used for far more than just playing games. Many more readers are now aware of the benefits and satisfaction of combining their interest in computers with that of electronics. Construction of all types of electronic projects, both digital and analogue, is once again dominating hobby workrooms. PE is devoted to encouraging and educating you in this reviving interest, and will continue to publish authoritative articles suited to your level of electronic ability, whether you are involved in professional electronics, technological education, or simply an enthusiastic amateur who, like myself many years ago, craves for more knowledge.

For me, electronics is fascinating, instructional, and vital to the society in which we live. There can be few areas left in which it is not making its impact felt. Inevitably, many more aspects of life will become changed by further innovations. Ensuring that such advances are both possible and beneficial, requires knowledge, understanding and acceptance by not just experts, but also those whom the changes affect most. Through electronics and the pages of PE, you too can learn about and experience today's essential technology as it shapes tomorrow's world now - and it's fun.

THE EDITOR

OUR MAY 1987 ISSUE WILL BE ON SALE FRIDAY, APRIL 3rd 1987 (see page 31)

© Intrapress 1987. Copyright in all drawings, photographs and articles published in PRACTICAL ELECTRONICS is fully protected, and reproduction or imitations in whole or part are expressly forbidden. All reasonable precautions are taken by PRACTICAL ELECTRONICS to ensure that the advice and data given to readers is reliable. We cannot, however, guarantee it, and we cannot accept legal responsibility for it. Prices quoted are those current as we go to press.

BBC Micro Computer System

BBC Master Series	Second Drive Kit.....£99 (c)
AMB15 BBC MASTER Foundation computer 128K.....£395 (a)	UPGRADE KITS
AMB12 BBC MASTER Econet computer 128K (only ANFS).....£319 (a)	1770 DFS Upgrade for Model B £43.50 (d)
AMC06 Turbo (65C102) Expansion Module.....£105 (b)	Basic II ROM.....£22.50 (d)
ADF13 Rom Cartridge.....£13 (d)	1.2 OS ROM.....£15 (d)
ADF10 Econet Module.....£43 (c)	DNFS ROM.....£17.50 (d)
ADJ22 Ref. Manual Part I.....£14.95 (c)	ADFS Rom (for B with 1770 DFS & B Plus).....£26 (d)
ADJ23 Ref. Manual Part II.....£14.95 (c)	64K Upgrade Kit for B Plus.....£35 (d)
ADJ24 Advanced Ref. Manual.....£19.50 (c)	ECONET ACCESSORIES
ACORN ADD-ON PRODUCTS	Econet Starter kit.....£85 (d)
6502 2nd Processor.....£179*	Econet Socket Set.....£29 (c)
Torch ZEP 100.....£229 (a)	Econet Bridge.....£174 (b)
Multiform Z80 2nd Processor.....£299 (b)	File Server Level II.....£120 (b)
Acorn Teletext Adaptor.....£125 (b)	Printer Server Rom.....£41 (d)
Acorn IEEE Interface.....£269 (a)	10 Stallion Lead set.....£26 (d)
BBC Master Compact SYSTEM 1	Adv. Econet User Guide.....£10 (d)
128K, Single 640K Drive & bundled software.....£399 (a)	COMMUNICATIONS ROMS
SYSTEM 2	Terminator.....£25 (d)
System 1 with a 12" Med-Res RGB Monitor.....£469 (a)	Communicator.....£49 (d)
SYSTEM 3	Commstar.....£28 (d)
System 1 with a 14" Med Res RGB Monitor.....£599 (a)	DATABEEB.....£24 (d)
	BBC FIRMWARE & SOFTWARE
	Database Management Systems, Word Processors, Languages, Spreadsheets, Utilities
	For full details on the wide range of above packages please write to us.

DISC DRIVES

These are fully cased and wired drives with slim line high quality mechanisms. Drives supplied with cables manuals and formatting disc suitable for the BBC computer. All 80 track drives are supplied with 40/80 track switching as standard. All drives can operate in single or dual density format.

PDP800P (2 x 400K/2 x 640K 40/80T DS) with built in monitor stand.....£263 (a)	PS400 with psu 1 x 400K/1 x 640K 40/80T DS.....£129 (b)
PD800 (2 x 400K/2 x 640K 40/80T DS).....£245 (a)	3.5" DRIVES
TD800 (as PD800 but without psu).....£226 (a)	1 x 400K/1 x 640K 80T DS TS35.....£99 (b)
TS400 1 x 400K/1 x 640K 40/80T DS.....£114 (b)	PS35 1 with psu.....£119 (b)
	2 x 400K/1 x 640K 80T DS TD35.....£170 (b)
	PD35 2 with psu.....£187 (b)

3M FLOPPY DISCS

High quality discs that offer a reliable error free performance for life. Each disc is individually tested and guaranteed for life. Ten discs are supplied in a sturdy cardboard box.

5 1/4" DISCS	3 1/2" DISCS
40T SS DD £10.50 (d)	40T DS DD £12.75 (d)
80T SS DD £16.50 (d)	80T SS DD £20.00 (d)
	80T DS DD £16.50 (d)
	80T DS DD £27.00 (d)

DISC ACCESSORIES

FLOPPICLENE Disc Head Cleaning Kit with 20 disposable cleaning discs ensures continued optimum performance of the drives... 3 1/2" £16 (d), 5 1/4" £14.50 (d)

Single Disc Cable.....£6 (d)	Dual Disc Cable.....£8.50 (d)
10 Disc Library Case.....£1.80 (c)	30 Disc Case.....£6 (c)
40 Disc Lockable Box.....£8.50 (c)	100 Disc Lockable Box.....£13 (c)

PRINTERS

EPSON	
LX86NLQ (80 col).....£229 (a)	
FX85 (80col) NLQ 8K RAM.....£315 (a)	
FX105 (136col).....£449 (a)	
LQ800 (80col).....£459 (a)	
LQ1000 (136col).....£659 (a)	
JX80 4 colour.....£420 (a)	
TAXAN KP10 (80col) NLQ £219 (a)	
TAXAN KP91 (156col).....£389 (a)	
NATIONAL PANASONIC KXP1080 (80col).....£159 (a)	
STAR NL10 (Parallel I'face).....£239 (a)	
STAR NL10 (Serial I'face).....£279 (a)	
JUKI 6100 Daisy.....£249 (a)	
BROTHER HR15 Daisy Wheel.....£299 (a)	
CANNON PJ1080A (Colour).....£409 (a)	
INTEGREX Inkjet Colour.....£549 (a)	
EPSONH180 A4 Plotter.....£325 (a)	
HITACHI 672 A3 Plotter.....£464 (a)	

Paper:

2000 Sheets Fanfold:	
9.5" x 11".....£13 (b)	
14.5" x 11".....£18.50 (b)	
Labels: (per 1000)	
3.5" x 17/16" Single row.....£5.25 (d)	
2 1/16" x 17/16" Triple row.....£5.00 (d)	

ACCESSORIES

EPSON	
FX plus sheet feeder.....£129.00 (b)	
LX80 Sheet feeder.....£48.00 (b)	
Paper Roll Holder.....£17.00 (d)	
FX80 Tractor attachment.....£37.00 (c)	
Interfaces: 8143 RS232.....£28.00 (c)	
8146 RS232 + 2K.....£57.00 (c)	
8132 Apple II.....£80.00 (c)	
8165 IEEE + cable.....£85.00 (c)	
Serial & Parallel interfaces with larger buffers available.	
Ribbons: RX/FX/MX80.....£5.00 (d)	
RX/FX/MX100.....£10.00 (d)	
LX80.....£8.00 (d)	
Spare pens for H180.....£7.50/set (d)	
FX80 Tractor Attachment £37 (c)	
KAGA TAXAN	
RS232 Interface + 2K Buffer.....£85 (c)	
Ribbon KP810/910.....£8.00 (d)	
JUKI:	
RS232 Interface.....£85 (c)	
Spare Daisy Wheel.....£14.00 (d)	
Ribbon.....£2.50 (d)	
Tractor Feed Attachment.....£182 (a)	
BROTHER HR15:	
Sheet Feeder.....£189 (a)	
Tractor Feeder.....£98 (a)	
Ribbons Carbon or Nylon.....£4.50 (d)	
Red Correction Ribbon.....£2.00 (d)	
BBC Printer Lead:	
Parallel (42").....£7.00 (d)	
Serial.....£7.00 (d)	
Printer Leads can be supplied to any length.	

MONITORS

All 14" monitors now available in plastic or metal cases, please specify.

MICROVITEC: 14" RGB	14" RGB with PAL & Audio
1431 Std Res.....£179 (a)	1431 AP Std Res.....£195 (a)
1451 med Res.....£225 (a)	1451 AP Med Res.....£260 (a)
1441 Hi Res.....£365 (a)	
Swivel Base for Plastic 14" Microvitecs.....£20 (c)	
20" RGB with PAL & Audio	
2030CS Std Res.....£380 (a)	2040CS Hi Res.....£685 (a)
TAXAN SUPERVISION II.....£279 (a)	
TAXAN SUPERVISION III with amber/green option, BBC & IBM.....£325 (a)	
MITSUBISHI XC1404 14" RGB Med Res IBM & BBC Compatible.....£229 (a)	
MONOCHROME MONITORS:	
TAXAN KX1201G Hi Res 12" Etched Green Screen.....£90 (a)	
TAXAN KX1202G Hi Res 12" Long Persistence (P39).....£98 (a)	
TAXAN KX1203A Hi Res 12" Etched Amber Screen.....£96 (a)	
PHILIPS BM7502 12" Hi Res Green Screen.....£75 (a)	
PHILIPS BM7522 12" Hi Res Amber Screen.....£79 (a)	
HANTAREX HX12.....£69 (a)	
Swivel Base for Taxan Monochrome fitted with Digital Clock.....£21 (c)	

MODEMS

— All modems listed below are BT approved

MIRACLE 3000:

MIRACLE WS2000 V21/23 Manual.....£99 (b)
MIRACLE WS4000 V21/23. (Hayes Compatible, Intelligent, Auto Dial/Auto Answer).....£149 (b)
MIRACLE WS3000 V21/V23 As WS4000 and with BELL standards and battery pack up for memory.....£275 (b)
MIRACLE WS3000 V22 As WS3000 V21/V23 but with 1200 baud full duplex.....£475 (a)
MIRACLE WS3000 V22 bis As V22 and 2400 baud full duplex.....£629 (a)
MIRACLE WS3022 As WS3000 but with only 1200/1200.....£395 (a)
MIRACLE WS3024 As WS3000 but with only 2400/2400.....£570 (b)
DATA Cable for WS series/PC or XT.....£10 (d)

DATATALK Comms Package 'If purchased with any of the above modems'.....£70 (c)

PACER Nightingale Modem V21/V23 Manual.....£95 (b)

Serial Test Cable

Serial Cable switchable at both ends allowing pin options to be re-routed or linked at either end using a 10 way switch making it possible to produce almost any cable configuration on site.

Available as M/M or M/F.....£24.75 (d)

SPECIAL OFFER

2764-25.....£2.00
27128-25.....£2.50
6264LP-15.....£3.40

Serial Mini Patch Box

Allows an easy method to reconfigure pin functions without rewiring the cable assy.

Jumpers can be used and reused.....£22 (d)

ATTENTION

All prices in this double page advertisement are subject to change without notice.

ALL PRICES EXCLUDE VAT

Please add carriage 50p unless indicated as follows:

(a) £8 (b) £2.50 (c) £1.50 (d) £1.00

Serial Mini Test

Monitors RS232C and CCITT V24

Transmissions, indicating status with dual colour LEDs on 7 most significant lines.

Connects in Line.....£22.50 (d)

GANG OF EIGHT INTELLIGENT FAST EPROM COPIER

Copies up to eight eproms at a time and accepts all single rail eproms up to 27256. Can reduce programming time by 80% by using manufacturer's suggested algorithms. Fixed Vpp of 21 & 25 volts and variable Vpp factory set at 12.5 volts. LCD display with alpha moving message. £395 (b).

SOFTY II

This low cost intelligent eprom programmer can program 2716, 2516, 2532, 2732, and with an adaptor, 2564 and 2764. Displays 512 byte page on TV — has a serial and parallel I/O routines. Can be used as an emulator, cassette interface. Softy II.....£195 (b)

Adaptor for 2764/2564. £25.00 (c)

UV ERASERS

All erasers with built in safety switch and main indicator.

UV1 B erases up to 6 eproms at a time.....£47 (c)
UV1 T as above but with a timer.....£59 (c)
UV140 erases up to 14 eproms at a time.....£88 (b)
UV141 as above but with a timer.....£88 (b)

I.D. CONNECTORS

(Speedblock Type)			
No of Header ways	Receptacle	Edge Conn.	
10	90p	85p	120p
20	145p	125p	195p
26	175p	150p	240p
34	200p	160p	320p
40	220p	190p	340p
50	235p	200p	390p

D CONNECTORS			
No of Ways			
	9	15	25
MALE:			
Ang.Pins	120	180	230
Solder	60	85	125
IDC	175	275	325
FEMALE:			
St Pin	100	140	210
Ang.pins	160	210	275
Solder	90	130	195
IDC	195	325	375
St Hood	90	95	100
Screw	130	150	175
Lock			

TEXTOOTL ZIF			
SOCKETS			
28-pin	£9.00	24-pin	£7.50
		40-pin	£12

EDGE CONNECTORS

2 x 6-way (commodore)	0.1"	300p
2 x 10-way	150p	—
2 x 12-way (vic 20)	—	350p
2 x 18-way	—	140p
2 x 23-way (ZX81)	175p	220p
2 x 25-way	225p	—
2 x 28-way (Spectrum)	200p	—
2 x 36-way	250p	—
1 x 43-way	260p	—
2 x 22-way	180p	—
2 x 43-way	395p	—
1 x 77-way	400p	—
2 x 50-way (S100conn)	600p	—

EURO CONNECTORS

Plug Socket	
DIN A1612	230p 275p
2 x 32 way St Pin	230p 275p
2 x 32 way Ang Pin	275p 320p
3 x 32 way St Pin	260p 300p
3 x 32 way Ang Pin	375p 400p
IDC Skt A + B	400p
IDC Skt A + C	400p
For 2 x 32 way please specify spacing (A + B, A + C).	

MISC CONNS	
21 pin Scart Connector	200p
8 pin Video Connector	200p

AMPHENOL CONNECTORS

Solder ZDC	
36 way plug	500p 475p
36 way skt	550p 500p
24 way plug	—
IEEE	475p 475p
24 way skt	—
IEEE	500p 500p
PCB Mtg Skt Ang Pin	—
24 way 700p	36way 750p

GENDER CHANGERS

25 way D type	
Male to Male.....	£10
Male to Female.....	£10
Female to Female.....	£10

RS 232 JUMPERS

(25 way D)	
24" Single end Female	£5.00
24" Single end Male	£5.25
24" Female Female	£10.00
24" Male Male	£9.50
24" Male Female	£9.50

RIBBON

(grey/metre)			
10-way	40p	34-way	160p
16-way	60p	40-way	180p
20-way	85p	50-way	200p
26-way	120p	64-way	220p

DIL HEADERS

Solder IDC		
14 pin	40p	100p
16 pin	50p	110p
18 pin	60p	-
20 pin	75p	-
24 pin	100p	150p
28 pin	180p	200p
40 pin	200p	225p

TECHNOLINE VIEWDATA SYSTEM

Using 'Prestel' type protocols for information and orders phone 01-450 9764. 24 hour service, 7 days a week.

EXPERIMENTAL ELECTRONICS

BY THE PROF

Inductive loop transmission

Inductive loop systems have some valuable practical applications, such as, for example, large scale hearing aid transmitters in public places. The Prof peruses the principles.

INDUCTIVE loop transmission and reception is one of those things I have been meaning to try out for quite some time (about 20 years), but I have only just got around to it now. I do not know and have not been able to trace the history of this method of communication, but it almost certainly dates back to the very early days of electronics, and is not something that requires any high technology components in order to produce a working system. In fact it is basically just two amplifiers and two coils of wire.

It has to be pointed out straight away that we are not talking about a communications system of the radio or intercom type, but more something to enable signals to be picked up anywhere within a room. A system of this type may seem to be of little or no practical value, but it does have practical applications. The obvious use is as the basis of a "cordless" headphone system, where electronics mounted on the headphones pick up the signal radiated by the transmitter, and the user is free from any direct connection to the radio, television, or other signal source. This is essentially the same idea as the infra-red style cordless headphones which have been around for many years now, but it is potentially a much cheaper and easier system to implement. On the other hand, it perhaps offers a level of performance

that is slightly less good in some respects than that of a good infra-red system, and it is somewhat more difficult to install. Which system is the most suitable therefore depends on the exact circumstances under which the system will be used, and on the level of performance required. For the present we will not consider the infra-red system further, but as far as the electronics are concerned it is basically the same as the infra-red communicator featured in the first article in this series. This is a topic to which we may well return in a future article.

Although any system of this general type may seem to be a gimmick and an unnecessary expense rather than a genuinely worthwhile proposition, anyone who has used headphones extensively will probably immediately appreciate the convenience of cordless headphones. In particular, it avoids the nearly neck breaking experience of getting up from a chair while standing on the headphone lead, or when walking around wearing headphones, literally reaching the end of ones tether.

Although I have no first hand knowledge of modern hearing aids, apparently many modern types can be switched from the normal microphone source to an inductive pick-up. The pick-up is primarily intended for use with telephones in much the same way as the

telephone pick-up coils used with telephone amplifiers, but they can also be used in halls, cinemas, etc. which have a suitable transmission system.

LOOPING THE LOOP

When dealing with a subject of this type it is very easy to get embroiled in pages of mathematics, but the system consists of what is really just an enormous and inefficient transformer with amplifiers at the input and output to overcome the losses. The block diagram of Fig. 1 outlines the requirements for a practical inductive loop communications system.

The transmitter is just an audio power amplifier feeding the transmission loop. The latter is just a loop of wire around the periphery of the room in which the system is to function, and it can consist of just a single turn. However, the strength of the magnetic field within the loop is dependent upon the current in the coil and the number of turns in the transmission coil. In order to produce a strong field it is therefore necessary either to have a very high current of a few amps in the coil, or to have several turns.

In practice an ordinary power amplifier can produce quite a high output current and give a fairly strong field with a single turn, but the impedance of such a transmission loop is likely to be far

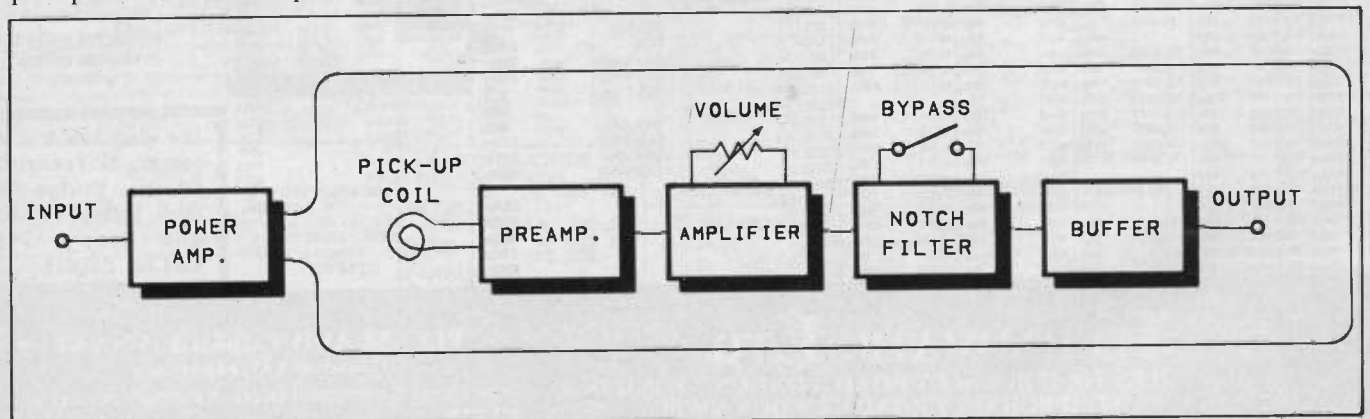

Fig.1. Block diagram for a practical inductive loop system.

lower than that of a standard 8 ohm impedance loudspeaker. This obviously depends on factors such as the length of the wire in the loop and its resistance, but unless the system is fitted to a very large room, the impedance of a single turn loop is likely to be less than a couple of ohms. In order to get good efficiency from the system it is therefore necessary either to feed the transmission loop via a step-down transformer, or to use more turns in order to give the coil a higher impedance. On the face of it the step-down transformer is the easier way of doing things, but a suitable ready-made component would almost certainly be impossible to obtain. A transformer could also result in some loss of performance, particularly in terms of frequency response and distortion. The extra effort needed to add a few additional turns onto the transmission coil is therefore probably the easier and better alternative.

A pick-up coil is needed at the receiver, and even a small air-spaced coil having just a few turns seems to give a reasonable amount of pick up. Not surprisingly though, of the various inductors that I tried a telephone pick-up coil gave by far the best results. The output from the coil is not likely to be very great, and when used with a telephone the output level would typically be around 500 microvolts r.m.s. In this application a higher output level can be obtained from the coil. The output level is still likely to be a matter of a few millivolts r.m.s., and a preamplifier is used to boost it to a higher level before any signal processing is undertaken. In fact two stages of amplification are used, with a volume control being included in this part of the unit.

This signal processing simply consists of a 50 Hertz notch filter which can be switched into circuit if desired. The main problem with an inductive loop communications system is that the pick-up coil will respond to any magnetic field which has audio frequency modulation, and not just to the field radiated by the transmitter. There are few likely sources of such fields, but the main one that has to be contended with, and which can generate quite a strong field, is the mains wiring. The 50 Hertz notch filter will severely attenuate any mains "hum", but it is not a total solution to the problem. One obvious drawback of using the filter is that it gives a loss of wanted bass signals as well as the unwanted mains "hum". Also it only attenuates the 50 Hertz fundamental signal, and has little effect on 100 Hertz and higher harmonics, which are likely to be present at lower but still quite significant strengths.

The 50 Hertz notch filter is a useful addition to the unit, but it should be regarded as a last resort, and other means of combating mains interference

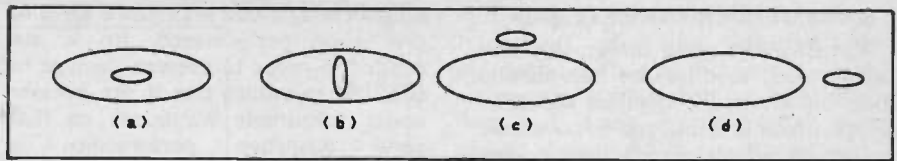

Fig.2. Relative transmission and pick-up coil orientations. (a) gives optimum pick-up, (b) gives minimum, (c) gives slightly less than maximum and (d) provides little output signal.

should be used where possible. The main way of reducing the "hum" to an insignificant level is to strive for the highest possible field strength from the transmitter. This enables the gain of the receiver to be kept well backed-off, and any background noise ("hum" or otherwise) to be effectively reduced.

Another method which can be used to good effect is to utilise the directivity of the pick-up coil. Fig.2 helps to explain the way in which this functions. In Fig.2(a) the transmission loop and pick-up coil are properly aligned and in the same plane, and this gives maximum output from the pick-up coil. The field strength is not uniform within the area enclosed by the transmission coil, but it varies by less than one would probably expect. The volume seems to remain virtually constant within the area covered by the unit, although it does become very much stronger if the pick-up coil is placed within about 300 millimetres or so of any part of the transmission coil.

Minimum pick-up is obtained with the pick-up rotated through 90 degrees, as in Fig.2(b). In fact, if the pick-up coil is rotated carefully, it can usually be set to completely null the signal from the transmitter. In the same way, the coil can be rotated to null the signal from a source of interference, and with luck it will be possible to find an orientation that gives good pick-up of the wanted signal while totally eliminating any interference. This is analogous to rotating a medium wave

radio receiver that has a ferrite rod aerial to null an interfering signal.

While on the subject of relative field strengths, it is worth pointing out that the field is strongest within the transmission loop. Moving the coil upwards, as in Fig.2(c), (or downwards of course), results in a reduction in the strength of the received signal. This should be borne in mind when installing the transmission coil, as it should ideally be at about the same height as the receiver unit will be in normal use, which is probably about one metre above floor level. In practice this might be difficult, and the coil may have to be fitted at floor or almost ceiling height. This should still give a strong signal at the receiver, but any mains "hum" or other interference will be that much more prominent.

If the loop is taken outside the transmission loop, as in Fig.2(d), the strength of the received signal seems to rapidly diminish as the receiver is moved away from the coil. The practical result of this is that it is unlikely that satisfactory results will be obtained if the receiver is used in one room when the transmission loop is installed in the next room. Either the loop must embrace both rooms, or each room must have its own inductive loop transmitter system.

Returning now to the block diagram of Fig.1, the output from the notch filter is fed to a buffer amplifier. This is needed to give an output that is capable of driving most types of headphone or earpiece.

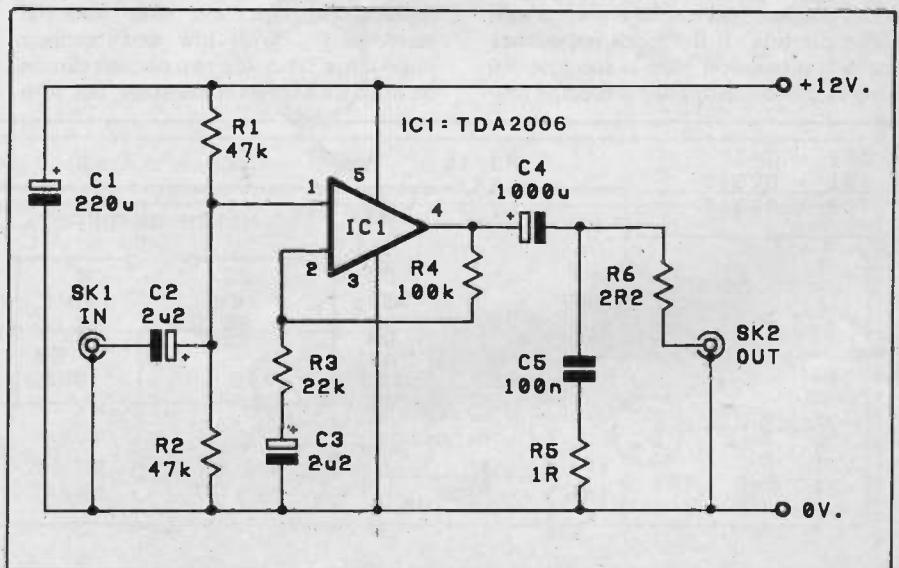

Fig.3. The transmitter circuit diagram.

TRANSMITTER CIRCUIT

Virtually any small power amplifier can be used to drive the transmission loop, but ideally the amplifier should be a type which is stable and has overload protection circuits, as the output loading is something of an unknown quantity. An amplifier that is fussy about the output loading could well give problems with instability, and a type which lacks any output overload protection could well be damaged if the impedance of the transmission loop proved to be somewhat too low.

I used the circuit shown in Fig.3, and this proved to give very good results. It is based on the TDA2006 audio power amplifier chip, which is rather like a high power operational amplifier. The device has the standard operational amplifier style inverting and non-inverting inputs, but unlike many audio power amplifiers, it does not include any internal biasing or feedback resistors. This device is more stable than most audio power amplifier integrated circuits (and discrete designs), and it has comprehensive output overload and thermal protection circuits.

It is operated here in what is just the ordinary non-inverting mode amplifier circuit, but as a single supply rail is used, R1 and R2 are needed to bias the non-inverting input. R3 and R4 set the voltage gain at about 5.5 times, which should be adequate for most signal sources, but the gain can easily be boosted if necessary, by increasing the value of R4. C5 and R5 are the usual C-R network used at the output of amplifiers to give improved stability, and they are the only compensation components that are needed in this case.

R6 ensures that the output of the amplifier is feeding into a reasonable load impedance. If the transmission loop provides a reasonably high input impedance (which in this context means around 4 ohms or more), R6 serves no useful purpose and can be replaced with a shorting link. If the input impedance of the transmission loop is too low, R6 ensures that the amplifier is feeding into

a high enough load impedance for it to give good performance. R6 is not needed in order to prevent damage to IC1, but to ensure that it can operate under favourable conditions so that good distortion performance is obtained. In order to get really good results from the system, the transmission coil should provide a suitable load impedance so that the losses caused by R6 are avoided, and the output signal of IC1 is efficiently coupled into the coil.

IC1 requires a minimum supply voltage of 12 volts, although the TDA2006s I tried seemed to work quite well down to 9 volts. There is no point in using a higher supply voltage, except in the unlikely event that the impedance of the transmission coil is so high that a higher supply voltage is needed, in order to drive it with a high current. IC1 has a class B output stage, and although the quiescent current consumption will only be about 40 milliamps, at high output levels the current consumption can be several hundred milliamps.

RECEIVER CIRCUIT

The receiver circuit diagram appears in Fig.4. The pick-up coil connects to SK1, and from here the signal is coupled to the input of a high gain common emitter amplifier built around TR1. From here the signal is taken via volume control VR1 to a second high gain common emitter stage, this time based on TR2. C6 to C8, and R6 to R8 form a conventional twin T notch filter having an operating frequency of about 50 Hertz, and S1 is the bypass switch. IC1 is the output buffer stage, and this is just a 741C operational amplifier connected as a voltage follower.

The current consumption of the unit is only about 4 milliamps or so, and the unit can be powered from a small (PP3 size) 9 volt battery. The output is suitable for high or medium impedance headphones, including the type sold as replacements for use with personal stereo units. With low and medium impedance types the two phones should be used with series connection, but with

high impedance types parallel connection will probably furnish greater volume. With some low and medium impedance types it may be found that great care has to be taken with the setting of the volume control in order to avoid an excessive output level. With headphones of this type it is preferable to add a resistor of about 47 ohms in series with the output to provide a certain amount of attenuation. The unit will also drive a crystal earphone at good volume, but it will not drive low impedance magnetic types very well, or any type of headphone that is intended to be driven direct from loudspeaker outputs.

PRACTICALITIES

Probably many readers will already have suitable amplifiers for experimenting with inductive loop systems, but for those who do not, or would prefer to use the designs described here anyway, printed circuit designs for the transmitter and receiver are shown in Figs.5 and 6 respectively. Both boards are very straightforward and require little amplification. One point that has to be made is that IC1 in the transmitter will almost certainly require a heatsink if overheating and thermal shut-down are to be avoided. The amount of heat-sinking required depends on the load impedance and on how hard the unit is driven, but for most purposes a small finned heatsink of the bolt-on variety will suffice.

For the transmission loop I used 24 s.w.g. enamelled copper wire, and for test purposes the system was rigged up in a room having approximate dimensions of 5 metres by 4 metres. Originally I used just a single turn on the coil, but this was later augmented to 4 turns, which seemed to give a better load impedance for the amplifier and a much stronger field. For this application some form of single strand insulated wire is probably more convenient than a multi-strand type, as single core wires are more easily formed into a desired shape. Do not worry about making the coil round - perfectly good results will be obtained

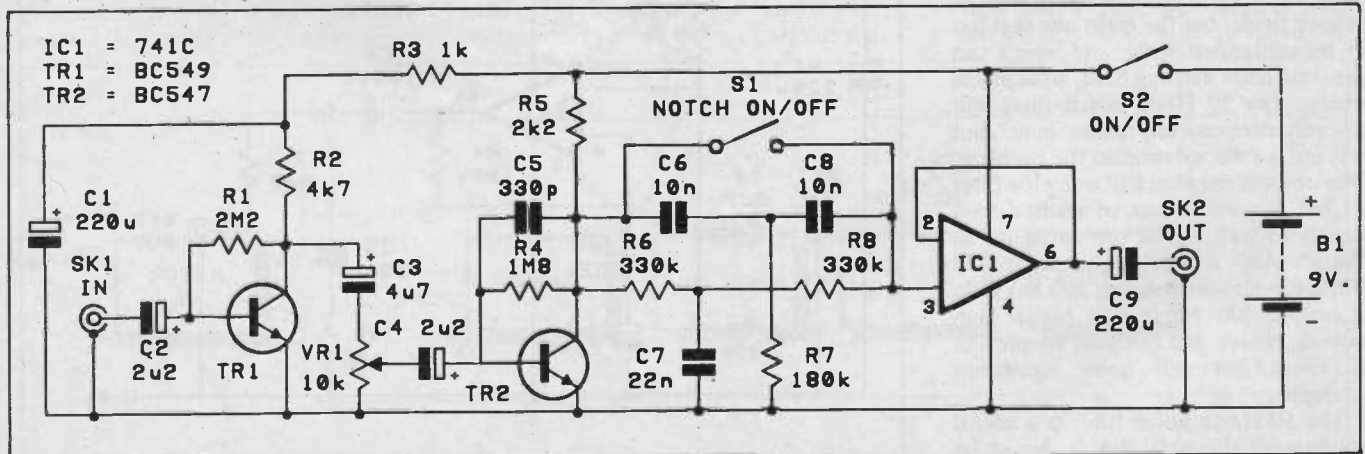

Fig.4. The receiver circuit diagram.

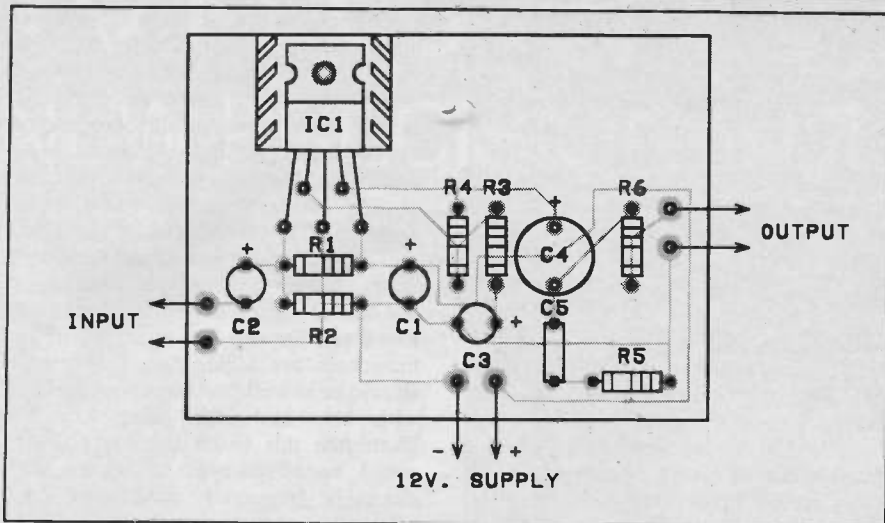

Fig.5. Details of the transmitter board.

into circuit. The input signal to the transmitter must be adjusted for optimum results, and this simply means setting the highest volume level that does not result in overloading and serious distortion. It is assumed here that the signal source has a volume control which can be used to set the input level to the unit, but if necessary a 10k logarithmic potentiometer can be wired volume control style at the input of the transmitter. The unit should not be fed direct from any piece of equipment that has a live chassis, except where this equipment has a properly isolated output, such as an earphone or tape socket, that can be safely used as signal take off point for the unit.

The receiver unit could be made quite small if necessary, and it would be quite feasible to build it onto a pair of headphones, although many modern types are of the ultra-lightweight type and it could be quite difficult with these. With a little ingenuity though, it should be possible to produce a bona fide pair of cordless headphones with a useful level of performance.

IMPROVEMENTS

For such a simple system, results seem remarkably good, but they are not so good that there is no room for improvement. How much mains "hum" is received depends on the conditions under which the system is used, but there will normally be a low but significant

COMPONENTS . . . TRANSMITTER

RESISTORS

- R1,R2 47k (2 off)
- R3 22k
- R4 100k
- R5 1R
- R6 2R2 ½ watt
- All ¼ watt 5% carbon unless noted

CAPACITORS

- C1 220µ 16Vradial elect

- C2,C3 2µ2 50Vradial elect (2 off)
- C4 1000µ 16Vradial elect
- C5 130n polyester

SEMICONDUCTOR

- IC1 TDA2006

MISCELLANEOUS

- SK1,SK2 Standard jacks (2 off)

Printed circuit board, wire for loop, heatsink for IC1, solder, etc.

with a rectangular coil, or practically any shape come to that. It is not even necessary to have the entire winding at the same height, and taking the wire up and around a door frame for example, does not seem to have any great effect on the level of performance. However, as explained previously, for optimum results the coil should be at about the same height as the receiver will be in normal use. The exact gauge of wire used is not too critical, but a very heavy gauge could give a rather low load impedance for the amplifier with consequent inefficient signal coupling. It could also be awkward from the installation point of view, while a very light gauge could be unable to handle the fairly high currents involved here, and could burn out. 24 s.w.g. wire offers a good compromise between these two extremes.

The pick-up coil can be left separate from the main receiver circuit and connected to the unit via SK1, or the latter can be omitted and the coil can then be mounted inside the case. If the pick-up coil is mounted in the case, keep in mind that optimum signal strength is obtained with the rubber suction cup facing either upwards or downwards.

If the unit is functioning properly there should be no shortage of volume from the receiver, and the audio quality should be quite good, if rather lacking in bass when the notch filter is switched

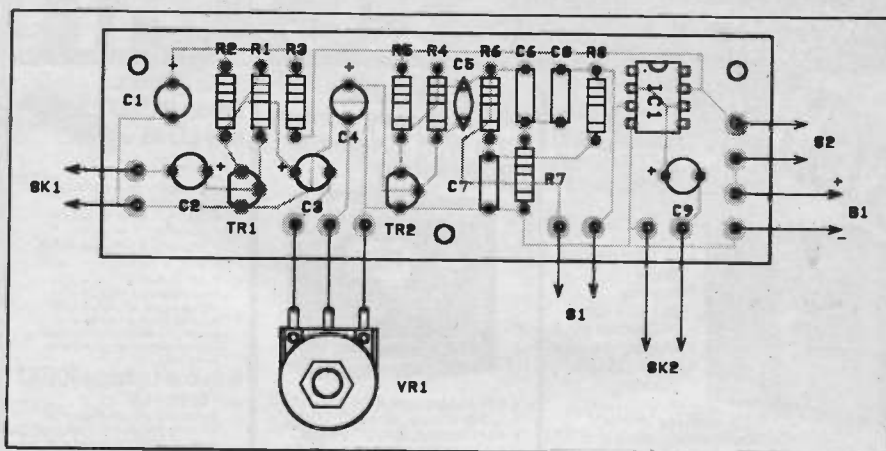
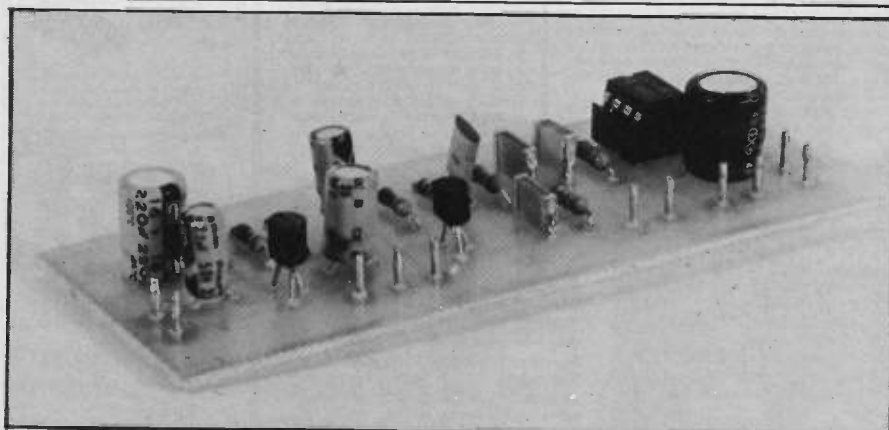

Fig.6. Details of the Receiver Board.



COMPONENTS . . .

RECEIVER

RESISTORS

- R1 2M2
 - R2 4k7
 - R3 1k
 - R4 1M8
 - R5 2k2
 - R6, R8 330k (2 off)
 - R7 180k
- All ¼ watt 5% carbon

POTENTIOMETER

- VR1 10k 10g

CAPACITORS

- C1, C9 220µ 10V radial elect (2 off)
- C2, C4 2µ 2 50V radial elect (2 off)

- C3 4µ 7 50V radial elect
- C5 330p ceramic plate
- C6, C8 10n polyester (2 off)
- C7 22n polyester

SEMICONDUCTORS

- IC1 741C
- TR1 BC549
- TR2 BC547

MISCELLANEOUS

- S1, S2 sub-min toggle (2 off)
- SK1, SK2 3.5mm jacks (2 off)
- B1 9 volt (PP3 size)

Printed circuit board, battery clip, 8 pin DIL i.c. holder, telephone pick-up coil, control knob, wire, solder, etc.

Perhaps the most obvious improvement would be to try to implement a stereo system. One way of doing this would be to have an ultrasonic carrier wave to carry the information needed for the additional channel, using a system of the same general type as that utilised in stereo FM radio transmissions. This could potentially cause radio interference and could be illegal, although there should be no problems if the carrier wave was kept at a relatively low level. On the face of it, if wireless intercoms are legal, then this system should be as well (but I have not checked with the authorities and can not guarantee this to be the case). There could be advantages to having both channels frequency modulated onto ultrasonic carrier waves. This would enable lower transmission powers to be used, and should give complete freedom from mains interference.

Another possible approach to stereo operation would be to have two transmission coils at right angles to one another (i.e. one around the four walls and the other around two walls, the floor, and the ceiling). With the two pick-up coils similarly orientated it should be possible to obtain sufficient channel separation for a good stereo image. However, while simple on paper this system could be practically impossible to implement in practice. **PI**

"hum" level. Increasing the field strength of the transmitter is the most effective way of counteracting sources of interference, and it is worthwhile experimenting with the number of turns in the transmission loop, in order to optimise the field strength. There is a limit to the field strength that can be obtained without resorting to very high transmitter powers, and a very strong field could give a few problems. In particular, there is a possibility of feedback to the signal source, and of

interference being caused to nearby radio receivers, record players, etc. What should be a very effective way of combating mains interference is to use a comb filter having a series of very narrow notches at frequencies of 50, 100, 150, 200 Hertz, etc. Provided the filter could be tuned accurately it would give a high degree of attenuation to the frequencies in the interference, but if the notches were narrow enough there would be surprisingly little effect on the audio output quality.

INSTALL YOUR OWN SYSTEM AND SAVE

SECURITY

MODULES ACCESSORIES KITS

NEW

"PASSIVE INFRA-RED INTRUDER DETECTOR RP33"



- 12 metre detection range.
- Size only 80 x 60 x 40mm.
- 24 Detection zones.
- Wide 85° coverage.
- Switchable LED indicator.

This advanced new intrusion detector operates by detecting the body heat of an intruder moving within the detection field. The use of a dual element pyroelectric sensor means that changes in ambient temperatures are ignored, thus providing a stable and reliable performance. Easily installed in a room or hallway, the unit will provide effective detection of any intrusion. Operating from a 12V supply and consuming only 15mA it is ideal for use with the CA 1382, CA 1250 or any equivalent high quality control unit. Supplied with full instructions, its performance compares with detectors costing more than twice the price.

£23.95 + V.A.T.

RISCOMP LIMITED

Dept. 7/4,
51 Poppy Road,
Princes Risborough,
BUCKS HP17 9DB
Tel: (084 44) 6326



CA 1382
An advanced control unit with automatic loop testing.



- Fully automatic siren re-set.
- Audible entry/exit warning.
- Alarm Sounded memory.
- 2 separate loop inputs + 24hr circuits.
- Built-in electronic siren.
- Easily installed, full instructions supplied.

This latest control panel provides effective and reliable control for all types of security installations. Its advanced circuitry checks the loop circuits every time it is switched on, preventing incorrect operation. Using a simple 'on/off' key switch, it is easily operated by all members of the family. In addition it provides 24 hr. personal attack protection. Housed in a steel case, it is supplied with full operating instructions.

Only £44.95 + V.A.T.
Available in kit form with fully-built electronics. £39.95 + V.A.T.

Order by 'phone or mail or call at our showroom and see

UNITS ON DEMONSTRATION

Monday to Friday 9.00 - 5.00 p.m.
Saturday 9.00 - 1.00 p.m.
Please add 15% VAT and 75p P&P to all UK orders
Export no VAT - postage at cost

Digital Ultrasonic Detector US 5063
only £13.95



+ V.A.T.

- 3 levels of discrimination against false alarms
 - Crystal control for greater stability
 - Adjustable range up to 25ft
 - Built-in delays
 - 12V operation
- This advanced module uses digital signal processing to provide the highest level of sensitivity whilst discriminating against potential 'false alarm conditions.

Individual Enclosure SC 5063
only £2.95 + V.A.T.

Suitable metal enclosure for housing the ultrasonic module type US 5063. Supplied with the necessary mounting pillars and screws etc.

Control Unit CA 1250
Price £19.95

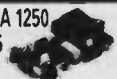

+ V.A.T.

This tried and tested control unit represents the finest value for money in control systems, providing the following features

- Built-in electronic siren drives 2 loud speakers
- Provides exit and entrance delays together with fixed alarm time
- Battery back-up with trickle charge facility
- Operates with magnetic switches, pressure pads, ultrasonic or I.R. units
- Anti-tamper and panic facility
- Stabilised output voltage
- 2 operating modes full alarm anti tamper and panic facility
- Screw connections for ease of installation
- Separate relay contacts for external loads
- Test loop facility

500W Quartz Halogen Floodlight FL 500



only £14.95 + V.A.T.

Whilst intended for security lighting applications, this unit is suitable for lighting patios, pathways and gardens etc. Supplied complete with 500W lamp, priced only £14.95 + V.A.T. Protective grill, £1.95 + V.A.T.

Lighting Controller DP 3570
only £13.95 + V.A.T.



This versatile module provides timed switching of loads up to 3A for pre-set times between 10 secs and 5 mins. The timed period being triggered by the opening or closing of an external loop or switch. The built-in 12V 250mA power supply is available for operating external sensors. Priced only £13.95 + V.A.T. Suitable plastic enclosure £2.85 + V.A.T.

HW 1250 - Enclosure & fixings for CA 1250



only £9.50 + V.A.T.

This attractive case is designed to house the control unit CA 1250 together with the appropriate LED indicators and key switch. Supplied with the necessary mounting pillars and punched front panel, the unit is given a professional appearance by an adhesive silk screened label. Size 200 x 180 x 70mm.

Infra-red System IR 1470



only £25.61 + V.A.T.

Consisting of separate transmitter and receiver both of which are housed in attractive moulded cases the system provides an invisible modulated beam over distances of up to 50ft operating a relay when the beam is broken. Intended for use in security systems, but also ideal for photographic and measurement applications. Size 80 x 50 x 35mm

SAMPLE OF OUR WIDE RANGE OF ACCESSORIES

- AL 243 - Automatic Light Switch Switches 3A at 240V - £4.30
- VS 39 - Vibration Contact - £2.30
- IS 128 - Miniature 12V Siren provides 100db output - £5.95
- SL 157 - Siren Module - £2.95
- HS 588 - 5½" Horn Speaker for use with control unit, siren module, etc. - £3.25

The above prices are plus V.A.T.

Complete systems from only £39.95 + V.A.T.

For full information of systems and accessories, send or call for details

MICRONTA®

NEW PRECISION MULTITESTERS



Ⓐ £49⁹⁵

Ⓑ £29⁹⁵

Ⓐ 23-Range Digital Multimeter

Features "beep" continuity test, diode-check mode. Measures to 1000 volts DC in 5 ranges, 500 volts AC in 4 ranges (accurate 45 Hz to 10 kHz). AC/DC current to 10A in 4 ranges, each. Resistance to 30 megohms in 6 ranges. Fold-out stand for bench-top use or for hanging up. Measures: 6³/₄ x 3¹/₁₆ x 1¹/₄". Fused and overload protected. Requires 4 "AA" batteries. Cat. No. 22-185

Ⓑ 43-Range Multimeter

50,000 ohms per volt DC sensitivity. Volts/amps range-doubler switch provides extra resolution for more accuracy, "beep" continuity check. Large 4¹/₂" mirrored scale. Measures to 1000 volts DC, 1000 volts AC, DC to 10 amps. Resistance to 20 megohms (10 ohms centre scale). Decibels: -20 to +62). Fused and overload protected. Measures: 6¹/₁₆ x 4⁷/₈ x 2³/₈". Requires 9v and "AA" battery. Cat. No. 22-214

Tandy®

For The Best In High Quality Electronics

Over 300 Tandy Stores And Dealerships Nationwide.
See Yellow Pages For Address Of Store Nearest You

Tandy UK, Tandy Centre, Leamore Lane, Bloxwich, Walsall, West Midlands. WS2 7PS

New Generation of Solderless Breadboards

Camboard have taken the normal breadboard and made it into sections, to form mini breadboards, which can then be spaced out on a mounting board to give more breadboarding area.

A Camboard mini breadboard consists of a plugblock with either gold (CM series) or tin (CM-T series) plated contacts, i.c.'s (max one 16 pin) are inserted in the centre and connect up with wires and components to form a small circuit or connect to other mini breadboards for larger circuits.

The Camboard mounting board has an alpha-numeric grid layout and measures 180mm x 129mm, giving more room to make bigger and more complex circuits.

Camboard brass terminals can be positioned to provide power for each mini breadboard, these can also be used for connecting up discrete components.

We then designed a tray to mount the board on, and store all the components in. Conductive foam is fitted so i.c.'s can be inserted before they are used on the main board, this protects them from being damaged by static. When not in use the breadboard can simply be turned over to protect the components on it. Holes enable switches, potentiometers etc to be mounted by the board and two colour coded power terminals connect up with a battery or PSU.

The contacts used in other breadboards are edge bearing contacts, which are oriented to contact the rough stamped edge of the i.c. lead, giving high contact resistance and little contact area. Our mini breadboards have overcome these problems, the contacts mate with the flat smooth side of the i.c. lead giving more contact area and lower contact resistance which results in better connections.

Each Camboard CM or CM-T series Breadboard comes with:
A. 1 Camboard Mounting Board; B. 25 Camboard Brass Terminals; C. 0, 1, 3 or 7 Camboard Mini Breadboards. The CM-T series also includes the component storage tray.



Model No.	Max No. 16 pin IC's	Unit Price
CM-0	0	£2.99
CM-1	1	£3.49
CM-3	3	£3.99
CM-7	7	£4.78
Mini breadboard (Gold plated contacts)	1	£0.99
CM-0T	0	£4.36
CM-1T	1	£4.79
CM-3T	3	£5.18
CM-7T	7	£6.92
Mini Breadboard (Tin plated contacts)	1	£0.44

All prices exclude VAT but include postage & packing
Export prices add 10%

How to order

Simply send your order, enclosing cheque or postal order to:

Camboard,
Unit 16 Barnwell Business Park,
Cambridge CB5 8UZ.
Telephone: Cambridge (0223) 240926

CAMBOARD

ELECTRONICS CAD

IBM PC (and compatibles) R.M. NIMBUS, BBC MODEL B, B+ and MASTER AMSTRAD CPC and SPECTRUM 48K.

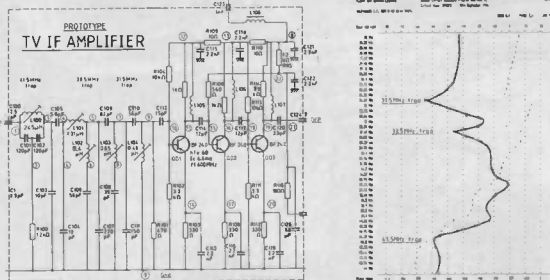

ANALYSER I and II compute the A.C. FREQUENCY RESPONSE of linear (analogue) circuits, GAIN and PHASE, INPUT IMPEDANCE, OUTPUT IMPEDANCE and GROUP DELAY (except Spectrum version) are calculated over any frequency range required. The programs are in use regularly for frequencies between 0.1GHz. The effects on performance of MODIFICATIONS to both circuit and component values can be speedily evaluated.

Circuits containing any combination of RESISTORS, CAPACITORS, INDUCTORS, TRANSFORMERS, BIPOLAR AND FIELD EFFECT TRANSISTORS and OPERATIONAL AMPLIFIERS can be simulated - up to 60 nodes and 180 components (IBM version).

Ideal for the analysis of ACTIVE and PASSIVE FILTER CIRCUITS, AUDIO AMPLIFIERS, LOUDSPEAKER CROSS-OVER NETWORKS, WIDE-BAND AMPLIFIERS, TUNED R.F. AMPLIFIERS, AERIAL MATCHING NETWORKS, TV 1.F. and CHROMA FILTER CIRCUITS, LINEAR INTEGRATED CIRCUITS. etc.

STABILITY CRITERIA AND OSCILLATOR CIRCUITS can be evaluated by "breaking the loop". Tabular output on Analyser I. Full graphical output, increased circuit size and active component library facilities on Analyser II.

Check out your new designs in minutes rather than days.

ANALYSER can greatly reduce or even eliminate the need to breadboard new designs. Full AFTER SALES SERVICE with TELEPHONE QUERY HOT LINE and FREE update service. Used by INDUSTRIAL, GOVERNMENT and UNIVERSITY R & D DEPARTMENTS worldwide. IDEAL FOR TRAINING COURSES, VERY EASY TO USE. Prices from £20-£195.

For further details and example computation or for details on our Drafting program, please write or phone:

NUMBER ONE SYSTEMS LTD,
Ref PE Crown Street, St Ives, Huntingdon, Cambs. PE17 4EB.
Tel: (0480) 61778



The new PE 30 + 30 integrated Amplifier (featured Practical Electronics Feb 87)

The PE 30 + 30 integrated amplifier is the first to benefit from Graham Nalty's research into Temperature Generated Distortion in transistors. As a result it exhibits a smoothness and musicality normally only expected from expensive valve amplifiers. Advanced power supply electronics and the use of Holco precision resistors in critical positions reaffirm its ability to give greater musical pleasure from your records, CDs and tapes. Yet you can buy the complete kit from AUDIOKITS for only £140 to build it yourself.

All parts for PE 30 + 30 are available separately.

AUDIOKITS Precision Components

AUDIOKITS supply highest grade audio components including Bulk file resistors IAR Wonder Caps, Holco precision resistors, gold plated switches and connectors, low noise transistor, best type of audio power transistors etc.

For details: 9" x 4" SAE to AUDIOKITS, 6 MILL CLOSE, BORROWASH, DERBY DE7 3GU. TEL: 0332-674929.

✂ TO: AUDIOKITS, 6 MILL CLOSE, BORROWASH, DERBY DE7 3GU.

Please supply:

Tick here

Price lists of kits and components. I enclose 9" x 4" SAE.

Parts list for PE 30 + 30. I enclose 9" x 4" SAE.

One complete PE 30 + 30 kit @ £140.

Two complete PE 30 + 30 kits @ £135 = £270.

Four complete PE 30 + 30 kits @ £130 = £520.

OMP POWER AMPLIFIER MODULES

* PRICES INCLUDE V.A.T. * PROMPT DELIVERIES * FRIENDLY SERVICE * LARGE S.A.E. 28p STAMP FOR CURRENT LIST

OMP POWER AMPLIFIER MODULES

Now enjoy a world-wide reputation for quality, reliability and performance at a realistic price. Four models available to suit the needs of the professional and hobby market, i.e. Industry, Leisure, Instrumental and Hi-Fi, etc. When comparing prices, NOTE all models include Toroidal power supply, Integral heat sink, Glass fibre P.C.B., and Drive circuits to power compatible Vu meter. Open and short circuit proof. **Supplied ready built and tested.**



OMP100 Mk II Bi-Polar Output power 110 watts R.M.S. into 4ohms. Frequency Response 15Hz - 30KHz -3dB, T.H.D. 0.01%, S.N.R. -118dB, Sens for Max output 500mV at 10K, Size 355 X 115 X 65mm. PRICE £33.99 + £3.00 P&P.



OMP/MF100 Mos-Fet Output power 110 watts R.M.S. into 4 ohms, Frequency Response 1Hz - 100KHz -3dB, Damping Factor 80, Slew Rate 45V/uS, T.H.D. Typical 0.002%, Input Sensitivity 500mV, S.N.R. -125dB, Size 300 X 123 X 60mm. PRICE £39.99 + £3.00 P&P.

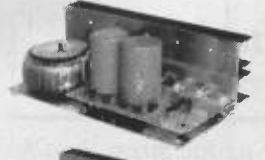

OMP/MF200 Mos-Fet Output power 200 watts R.M.S. into 4 ohms, Frequency Response 1Hz - 100KHz -3dB, Damping Factor 250, Slew Rate 50V/uS, T.H.D. Typical 0.001%, Input Sensitivity 500mV, S.N.R. -130dB, Size 300 X 150 X 100mm. PRICE £62.99 + £3.50 P&P.



OMP/MF300 Mos-Fet Output power 300 watts R.M.S. into 4 ohms, Frequency Response 1Hz - 100KHz -3dB, Damping Factor 350, Slew Rate 60V/uS, T.H.D. Typical 0.0008%, Input Sensitivity 500mV, S.N.R. -130dB, Size 330 X 147 X 102mm. PRICE £79.99 + £4.50 P&P.

NOTE: Mos-Fets are supplied as standard (100KHz bandwidth & Input Sensitivity 500mV). If required, P.A. version (50KHz bandwidth & Input Sensitivity 775mV). Order - Standard or P.A.

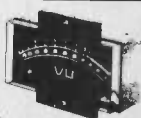

VU METER Compatible with our four amplifiers detailed above. A very accurate visual display employing 11 L.F.D. diodes (7 green, 4 red) plus an additional on/off indicator. Sophisticated logic control circuits for very fast rise and decay times. Tough moulded plastic case, with tinted acrylic front. Size 84 X 27 X 45mm. PRICE £8.50 + 50p P&P.

LOUDSPEAKERS 5" to 15" up to 400 WATTS R.M.S. Cabinet Fixing in stock. Huge selection of McKenzie Loudspeakers available including Cabinet Plans. Large S.A.E. (28p) for free details.



POWER RANGE
8" 50 WATT R.M.S. Hi-Fi/Disco.
20 oz magnet. 1 1/2" ally voice coil. Ground ally fixing escutcheon. Res. Freq 40Hz Freq Resp to 6KHz. Sens. 92dB. PRICE £10.99 Available with black grille £11.99 P&P £1.50 ea.
12" 100 WATT R.M.S. Hi-Fi/Disco
50 oz magnet. 2" ally voice coil. Ground ally fixing escutcheon. Die-cast chassis. White cone. Res. Freq. 25Hz. Freq. Resp. to 4KHz. Sens. 95dB. PRICE £28.60 + £3.00 P&P ea.

McKENZIE
12" 85 WATT R.M.S. C1285GP Lead Guitar/Keyboard/Disco.
2" ally voice coil. Ally centre dome. Res. Freq. 45Hz. Freq. Resp. to 6.5KHz. Sens. 98dB. PRICE £29.99 + £3.00 P&P ea.
12" 85 WATT R.M.S. C1285TC P.A./Disco 2" ally voice coil. Twin cone. Res. Freq. 45Hz. Freq. Resp. to 14KHz. PRICE £31.49 + £3.00 P&P ea.
15" 150 WATT R.M.S. C15 Bass Guitar/Disco.
3" ally voice coil. Die-cast chassis. Res. Freq. 40Hz. Freq. Resp. to 4KHz. PRICE £57.87 + £4.00 P&P ea.
10" 60 WATT R.M.S. 1060GP Gen. Purpose/Lead Guitar/Keyboard/Mid. P.A.
2" voice coil. Res. Freq. 75Hz. Freq. Resp. to 7.5KHz. Sens. 99dB. PRICE £19.99 + £2.00 P&P.
10" 200 WATT R.M.S. C10200GP Guitar/Keyboard/Disco.
2" voice coil. Res. Freq. 45Hz. Freq. Resp. to 7KHz. Sens. 101dB. PRICE £44.76 + £3.00 P&P.
15" 200 WATT R.M.S. C15200 High Power Bass.
Res. Freq. 40Hz. Freq. Resp. to 5KHz. Sens. 101dB. PRICE £62.41 + £4.00 P&P.
15" 400 WATT R.M.S. C15400 High Power Bass.
Res. Freq. 40Hz. Freq. Resp. to 4KHz. Sens. 102dB. PRICE £89.52 + £4.00 P&P.

WEM
5" 70 WATT R.M.S. Multiple Array Disco etc.
1" voice coil. Res. Freq. 52Hz. Freq. Resp. to 5KHz. Sens. 89dB. PRICE £22.00 + £1.50 P&P. ea.
8" 150 WATT R.M.S. Multiple Array Disco etc.
1" voice coil. Res. Freq. 48Hz. Freq. Resp. to 5KHz. Sens. 92dB. PRICE £32.00 + £1.50 P&P. ea.
10" 300 WATT R.M.S. Disco/Sound re-enforcement etc.
1 1/2" voice coil. Res. Freq. 35Hz. Freq. Resp. to 4KHz. Sens. 92dB. PRICE £36.00 + £2.00 P&P. ea.
12" 300 WATT R.M.S. Disco/Sound re-enforcement etc.
1 1/2" voice coil. Res. Freq. 35Hz. Freq. Resp. to 4KHz. Sens. 94dB. PRICE £47.00 + £3.00 P&P. ea.

SOUNDLAB (Full Range Twin Cone)
5" 60 WATT R.M.S. Hi-Fi/Multiple Array Disco etc.
1" voice coil. Res. Freq. 63Hz. Freq. Resp. to 20KHz. Sens. 86dB. PRICE £9.99 + £1.00 P&P. ea.
6 1/2" 60 WATT R.M.S. Hi-Fi/Multiple Array Disco etc.
1" voice coil. Res. Freq. 56Hz. Freq. Resp. to 20KHz. Sens. 89dB. PRICE £10.99 + £1.50 P&P. ea.
8" 60 WATT R.M.S. Hi-Fi/Multiple Array Disco etc.
1 1/4" voice coil. Res. Freq. 38Hz. Freq. Resp. to 20KHz. Sens. 89dB. PRICE £12.99 + £1.50 P&P. ea.
10" 60 WATT R.M.S. Hi-Fi/Disco etc.
1 1/2" voice coil. Res. Freq. 35Hz. Freq. Resp. to 15KHz. Sens. 89dB. PRICE £16.49 + £2.00 P&P.

PANTEC HOBBY KITS. Proven designs including glass fibre printed circuit board and high quality components complete with instructions.

FM MICROTRANSMITTER (BUG) 90/105MHz with very sensitive microphone. Range 100/300 metres. 57 x 46 x 14mm (9 volt) Price: £8.62 + 75p P&P.
3 WATT FM TRANSMITTER 3 WATT 85/115MHz veripac controlled professional performance. Range up to 3 miles 35 x 84 x 12mm (12 volt) Price: £14.49 + 75p P&P.
SINGLE CHANNEL RADIO CONTROLLED TRANSMITTER/RECEIVER 27MHz. Range up to 500 metres. Double coded modulation. Receiver output operates relay with 2amp/240 volt contacts. Ideal for many applications. Receiver 90 x 70 x 22mm (9/12 volt). Price: £17.82 Transmitter 80 x 50 x 15mm (9/12 volt). Price: £11.29 P&P + 75p each. S.A.E. for complete list.



POSTAL CHARGES PER ORDER £1.00 minimum. OFFICIAL ORDERS WELCOME. SCHOOLS, COLLEGES, GOVERNMENT BODIES, ETC. PRICES INCLUSIVE OF V.A.T. SALES COUNTER VISA/ACCESS/C.O.D. ACCEPTED.

BURGLAR ALARM

Better to be 'Alarmed' than terrified. Thandar's famous 'Minder' Burglar Alarm System. Superior microwave principle. Supplied as three units, complete with interconnection cable. **FULLY GUARANTEED.**
Control Unit - Houses microwave radar unit, range up to 15 metres, adjustable by sensitivity control. Three position, key operated fascia switch - off - test - armed 30 second exit and entry delay.
Indoor alarm - Electronic swept freq. siren 104dB output.
Outdoor Alarm - Electronic swept freq. siren 98dB output. Housed in a tamper-proof heavy duty metal case.
Both the control unit and outdoor alarm contain rechargeable batteries which provide full protection during mains failure. Power requirement 200/260 Volt AC 50/60Hz. Expandable with door sensors, panic buttons etc. Complete with instructions.

IDEAL for Work-shops, Factories, Offices, Home, etc. Supplied ready built.



SAVE £138.00 Usual Price £228.85
BKE's PRICE £89.99 + £4.00 P&P
? Why buy a collection of self-assembly boards!

OMP LINNET LOUDSPEAKERS

The very best in quality and value. Made specially to suit today's need for compactness with high sound output levels. Finished in hard wearing black vinyl with protective corners, grille and carry handle. All models 8 ohms. Full range 45Hz - 20KHz. Size 20" X 15" X 12". Watts R.M.S. per cabinet. Sensitivity 1W. 1mtr. dB



OMP 12-100 Watts 100dB. Price £149.99 per pair.
OMP 12-200 Watts 102dB. Price £199.99 per pair.
Delivery: Securior £8.00 per pair

OMP 19" STEREO RACK AMPS



Professional 19" cased Mos-Fet stereo amps. Used the World over in clubs, pubs, discos etc. With twin Vu meters, twin toroidal power supplies, XLR connections. MF600 Fan cooled. **Three models (Ratings R.M.S. into 4ohms). Input Sensitivity 775mV**
MF200 (100 + 100)W. £169.00 Securior
MF400 (200 + 200)W. £228.85 Delivery
MF600 (300 + 300)W. £322.00 £10.00

1 K-WATT SLIDE DIMMER

* Control loads up to 1KW
* Compact Size 4 1/2" X 1" X 2 1/2"
* Easy snap in fixing through panel/cabinet cut out
* Insulated plastic case
* Full wave control using 8 amp triac
* Conforms to BS800
* Suitable for both resistance and inductive loads. Innumerable applications in industry, the home, and disco's, theatres etc.
PRICE £13.99 + 75p P&P

BSR P295 ELECTRONIC TURNTABLE

* Electronic speed control 45 & 33 1/3 r.p.m. * Plus/Minus variable pitch control * Belt driven * Aluminium platter with strobed rim * Cue lever * Anti-skate (bias device) * Adjustable counter balance * Manual arm * Standard 1/2" cartridge fixings * Supplied complete with cut out template * D.C. Operation 9-14V D.C. 65mA
Price £36.99 - £3.00 P&P.

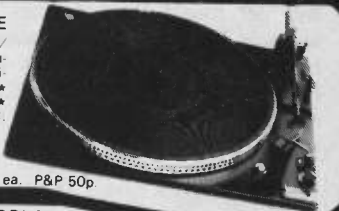

ADC Q4 mag. cartridge for above Price £4.99 ea. P&P 50p

PIEZO ELECTRIC TWEETERS MOTOROLA

Join the Piezo revolution. The low dynamic mass (no voice coil) of a Piezo tweeter produces an improved transient response with a lower distortion level than ordinary dynamic tweeters. As a crossover is not required these units can be added to existing speaker systems of up to 100 watts (more if 2 put in series). **FREE EXPLANATORY LEAFLETS SUPPLIED WITH EACH TWEETER.**

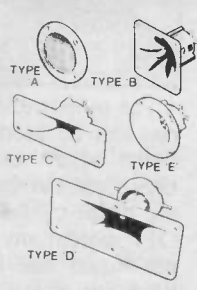

TYPE 'A' (KSN2036A) 3" round with protective wire mesh, ideal for bookshelf and medium sized Hi-fi speakers. Price £4.90 each + 40p P&P
TYPE 'B' (KSN1005A) 3 1/2" super horn. For general purpose speakers, disco and P.A. systems etc. Price £5.99 each + 40p P&P
TYPE 'C' (KSN6016A) 2" X 5" wide dispersion horn. For quality Hi-fi systems and quality discos etc. Price £6.99 each + 40p P&P
TYPE 'D' (KSN1025A) 2" X 6" wide dispersion horn. Upper frequency response retained extending down to mid range (2KHz). Suitable for high quality Hi-fi systems and quality discos. Price £9.99 each + 40p P&P
TYPE 'E' (KSN1038A) 3 3/4" horn tweeter with attractive silver finish trim. Suitable for Hi-fi monitor systems etc. Price £5.99 each + 40p P&P
LEVEL CONTROL Combines on a recessed mounting plate, level control and cabinet input jack socket. 85 X 85 mm. Price £3.99 + 40p P&P.

STEREO DISCO MIXER

STEREO DISCO MIXER with 2 X 5 band L & R graphic equalisers and twin 10 segment L.E.D. Vu Meters. Many outstanding features 5 Inputs with individual faders providing a useful combination of the following -
3 Turntables (Mag), 3 Mics, 4 Line plus Mic with talk over switch, Headphone Monitor, Pan Pot, L & R Master Output controls. Output 775mV. Size 360 X 280 X 90mm.
Price £134.99 - £3.00 P&P



B. K. ELECTRONICS Dept PE
UNIT 5, COMET WAY, SOUTHEND-ON-SEA,
ESSEX. SS2 6TR TEL: 0702-527572

P.E. "VIGILANTE" CAR ALARM

BY MIKE DELANEY

Cars attract burglars. The Vigilante repels them

This is a concealed alarm which can employ either the car horn or a separate sounder as the siren, and is operated via the car's courtesy light and ignition system.

IT IS a sad reflection of our times that it should be necessary to publish an article such as "Vigilante", but the facts speak for themselves. Car theft is an ever-increasing problem, to such an extent that the manufacturers have been forced to improve the quality of the locks they fit. This is fine for anyone buying one of the newer models with these fitted, but not all of us can afford a new car, and there's still a few miles left in my old model ...

It is important to realise at the outset that any alarm fitted to a vehicle is at best only a deterrent. The pro. car thief will get round most devices in a few seconds, or at best, a few minutes, but hopefully the joyrider, or late-night traveller, will be put off sufficiently to look for an easier target. If the alarm achieves this, it has done its job. But then, you'd never know it!

Incorporated in the Vigilante design are a couple of extra options to make life a bit easier for the owner. If you have ever left the lights on when parking on a foggy morning, to return after a day's work to the inevitable flat battery, then you will be pleased with one of the options. By taking a wire to the light switch it will signal when this line is high and the alarm is set.

The second is a circuit to hold on the courtesy light for a pre-determined period, or until the alarm is disabled. Many alarm systems presently on the market require the car owner to carry round a special key to enable and disable the alarm. This has been designed out in the case of the Vigilante. Although, if you wish, it is possible to fit another key-operated switch, the system may be operated through the vehicle ignition switch. Which method you choose depends upon how highly you rate the security offered by your vehicle keys. In many cases this is not too high!

Another, though not often used, option is for the system to be automatic. Each time the ignition is switched off the alarm sets itself. Useful for delivery-men, but not for the average driver.

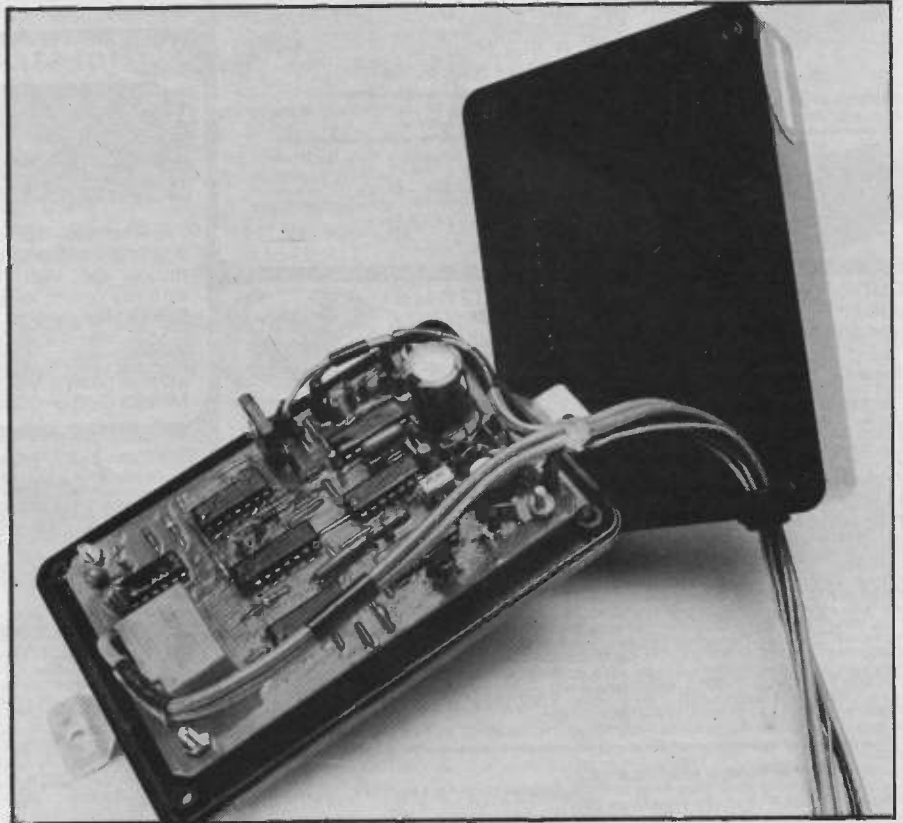

The output drive is a relay closure, so this can be used to power the vehicle horn, or an external piezo sounder. Quiescent current drain is very low, in the order of 4mA, so there is no ON/OFF switch; any car battery which cannot stand this drain would be quite unable to start an engine.

In order to comply with local bye-laws the unit resets itself after the alarm period, and allows an enter/exit period, with audible warning each time a door is opened. There are several ways of detecting an intruder in a vehicle. Some are better than others, but each requires that the owner drill at least one hole in his pride of joy. The Vigilante, by monitoring the voltage level within the car, reduces the number of external connections, and in the case of the author's car, required only one small hole to accept the 'set' switch.

Throughout the whole design the external state of the car wiring and switching is taken as shown in Fig.4., and if your vehicle does not conform to this you will need to do some interfacing of your own.

BLOCK DIAGRAM

The block diagram is shown in Fig.1. ON/OFF control of the circuit is achieved by the Enable flip flop. A Set switch turns the circuit on, and the car ignition switch turns it off.

When in the off condition, the Alert, Exit and Bark flip flops are all held in reset. Operating the Set switch flips over the Alert, and enables these three bistables. When the alarm is first set, the Exit flip flop is in its operate mode, and this toggles the Alert flip flop. The output from Alert goes high, turning on the interior light and the warning oscillator,

VIGILANTE CAR ALARM

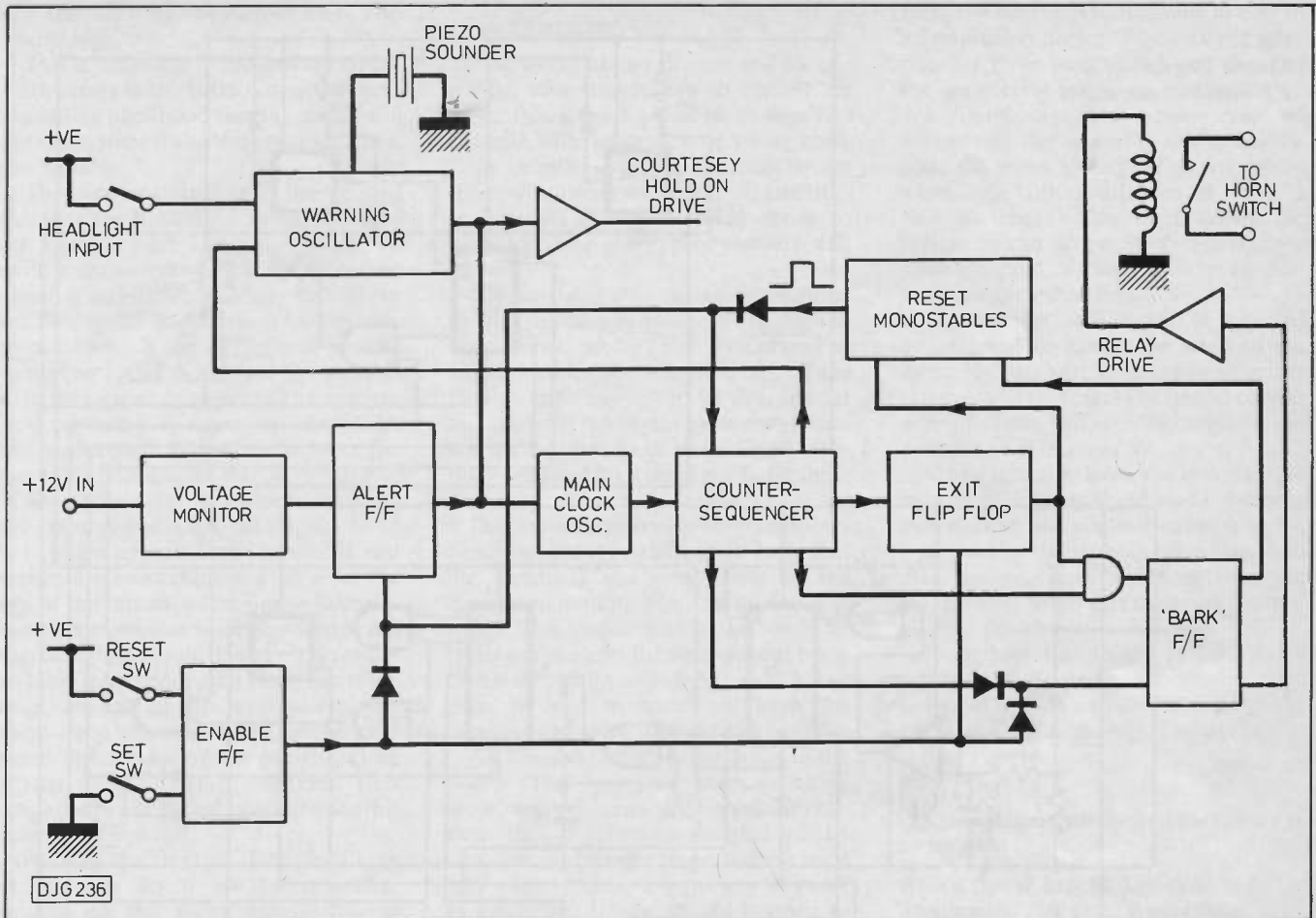

Fig.1. Block diagram of PE Vigilante car alarm

and starting the main clock oscillator. The counter/sequencer starts to count up from 0, and after the predetermined period outputs a high to the Exit flip flop. This high toggles Exit, putting a high to the monostable, resetting the Alert flip flop, and setting the counter to 0 count.

By ANDing the Exit output to the Bark, the circuit is prevented from sounding the alarm following the first exit period. The monostable quickly returns to its stable (LOW) condition, enabling the Alert and counter as before, and the circuit is now in its alert condition. The voltage monitor is constantly sampling the supply voltage stored on a capacitor on one of its inputs. When the 'live' voltage suddenly drops, in the space of a few milliseconds and a few hundreds of millivolts, the monitor sees the unbalance and toggles the Alert flip flop as before.

This time, since the Exit flip flop has been toggled to its active state when the alarm was first set, when the counter reaches the end of the Exit period, the Bark flip flop toggles, sounding the alarm. Following the alarm period, the counter puts a high onto the reset pin of the Bark flip flop, resetting it to the alert state, which in turn triggers the Reset mono, resetting the counter and Alert as before. The circuit returns to its

stable, Alert state, awaiting further triggers to the monitor.

Part of the warning oscillator is also monitoring the input from the lighting circuit in the car. When the warning is active, and the input from the light circuit is high, that is when the lights are on, the oscillator is gated such that the continuous tone becomes intermittent, signalling the lighting status. Of course, the fact that the lights are on will not affect the operation of the alarm.

THE CIRCUIT

The two system switches are the Set (S1), and Reset (S2) switches, and these are taken to the Enable flip flop, IC2b, half of a 4013.

The switches are isolated from direct connection by 1k resistors, to limit current into the i.c.s. in case of gross chip failure. The Set switch is buffered, and inverted by IC4b, before its output is taken to the flip flop. The reason for this arrangement is to allow the wiring to S1 to be as simple as possible when installing. It is only necessary to run one wire from the alarm to the switch, the other side of which can be connected, locally, direct to chassis. By arranging the two inputs as shown, the logic on the output is such that the ONLY time the output on pin 12 will be low will be when the input to pin 10 is low, and

the input to pin 8 is taken high. This arrangement ensures that no matter what might be done to the Set switch, it can only arm the circuit, and only the Reset (ignition) switch can turn the system off. Also, the circuit can only be set when the ignition is off.

When turned off the output on pin 12 of IC2 is high. This level holds Alert, IC2a and the counter in reset via D4, Exit via pin 10, and bark, IC7a through D7. IC3d inverts the level, and blocks the output from gate 6b, putting a low level onto the S input of the Alert flip flop, pin 6. When the alarm is set pin 12, IC2b goes low, enabling the three flip flops, and the counter. The output of gate 3d goes high, and since the logic output from the Exit flip flop, pin 12 is high, gate 6b's output also goes high.

This high level on pin 6 of IC2a sets the Q output high, and this enables the clock comprising gate 3c, C3 and R12. At the same time TR1 is turned hard on via R10, turning on the interior light, and D5 is reverse biased, which allows the warning oscillator to start up.

In the event of the lighting circuit being active, the input on pin 8 of gate 4c will be high. Divided-down pulses are taken from the counter chip, IC5, a 4020, fed to the other input pin 9, of gate 4c, inverted, and then fed to the warning oscillator gate, 4d on pin 12. In

VIGILANTE CAR ALARM

Fig.2.
Circuit diagram of
PE Vigilante car alarm

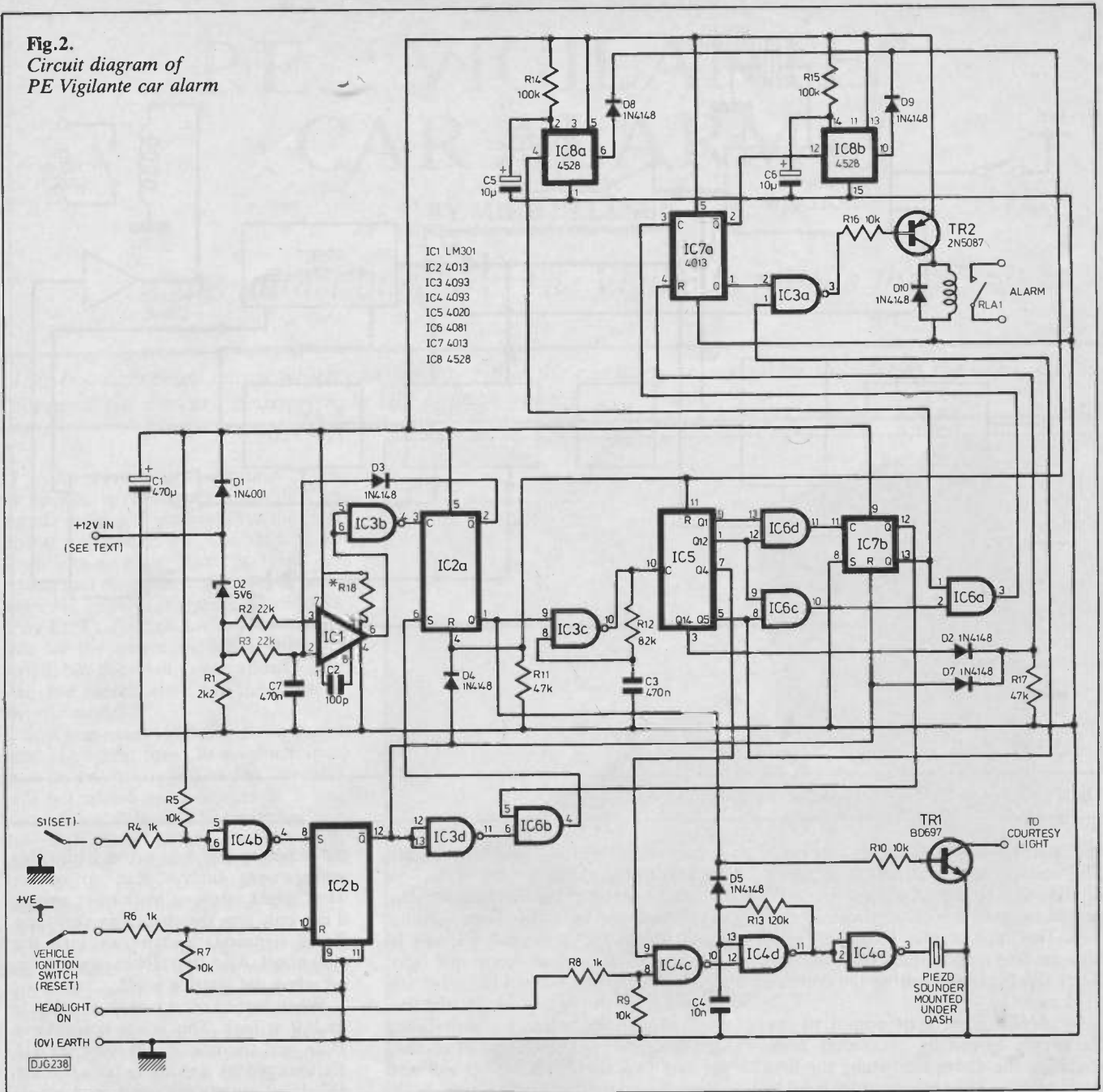

this way, if the lights are on when the warning period is being signalled, the warning oscillator is modulated at a slow rate to act as a "lights on" warning.

The output from the warning oscillator is buffered by gate 4a, and taken to the piezo sounder. As with the Set switch, the other end of the piezo is terminated to vehicle earth. The clock pulses to the counter are counted through, and after the 2049th, pin 11 of gate 6d goes high, which toggles the Exit flip flop 7b. Pin 13 goes high, and 12 goes low. This enables gate 6a by putting a high on pin 1, disables gate 6b, pin 5, and starts the monostable IC8a.

The output of the monostable immediately goes high on pin 6, and this resets the counter via D8 to 0 and puts the Alert bistable into the quiescent mode.

Gates 6d and 6c ensure that the Bark flip flop cannot be set when the Exit flip

flop is active, by arranging for one gate to allow through pulse 2049, and the Bark to be triggered by ANDing of 2049 with pulse 2064 in gate 6a.

In this way, the alarm allows the driver to Set, and to Exit, but only once. With the Exit flip flop now having been clocked by the counter, the only way it can be reset is by a high level on pin 10, taken from the Enable flip flop.

The supply is taken off the vehicle wiring at the fused side of interior light circuit. This is smoothed by diode D1, and C1. It is also applied to D2, a 5V6 zener and R1. This gives a voltage of approximately 7 volts at the anode of D2, and slightly less than this at pin 3 of the 301 op amp, IC1. R2 and R3 are equal in value to minimise the effects of input offset currents, and to ensure that there will be minimal voltage difference at the two inputs to the op amp. R3 and

C7 form a d.c. storage circuit, slowing down the response time to any change in voltage which may occur.

Resistor R18 is selected to give the required sensitivity to these voltage changes, by feeding in an offset to the op amp, and its value is selected under test. See below for details. When a sudden change *downwards* in the input voltage occurs, the two inputs to the op amp will momentarily become unbalanced. Pin 3 will track the fall, while Pin 2 will effectively remain high for several milliseconds. As soon as this happens the output of IC1 will go low. This change is inverted and buffered by IC3b, and a positive-going edge is applied to the Alert flip flop clock pin 3. The Alert outputs flip over, pin 1 going high, and 2 going low. The clock, warning and interior lights are enabled as before, and D3 is forward biased, discharging

VIGILANTE CAR ALARM

C7, and allowing the output of IC1 to return high.

This is necessary to prevent the circuit retriggering itself. If D3 is omitted there is a strong likelihood that the circuit will not reset, since it also draws current from the battery!

The counter counts up as before, and this time the Bark flip flop is clocked on pin 3, setting pin 1. This high is NANDed with a divided-down output from the counter, and drives the relay by TR2. In the final circuit board design it is possible to cut the track to pin 1 of gate 3a, and join pins 1 and 2, so that the relay is held on instead of pulsing. The counter now continues to count up until Q14, pin 3 goes high. When this happens the Bark flip flop is reset via D6, triggering IC8b, whose output goes high, resetting the counter and Alert once again.

It might appear that the use of two separate monostables is a bit over the top of this circuit, when simple differentiating components would have achieved the same end result. However, in order to keep the impedances of all the resetting low, and in this way maintaining good noise rejection (cars can be very noisy, electronically), the present set up is the most reliable solution. Your neighbours will probably appreciate this more than you do!

Holding the reset to IC2a pin 4 high in this way for a few seconds after turning off the alarm allows the car electrics to settle down prior to enabling the circuit again. This, in conjunction with the time constant formed by R3 and C7 ensures that false retriggering cannot occur.

CONSTRUCTION

The whole circuit is mounted on one p.c.b., with connections to the vehicle using flying leads soldered to tags and secured with cable ties or lacing cord. Bear in mind during construction that the environment in which the circuit is to be used is naturally very prone to vibration. Use shakeproof washers, and so on.

The board is quite small on purpose, so that the case can be small enough to tuck away under the bonnet. The author's alarm was mounted behind the battery, high enough to be dry, and far enough from the engine to be cool. There are quite a few links to be fitted – the price required for a small p.c.b. Fit these first.

The component layout diagram shows clearly where everything goes. Note that the resistors, and even some of the diodes are mounted on end to conserve space. This requires that the leads be bent over close to the component body. Do this *carefully*, and always allow about 3mm of lead to come out from the component *before* forming the bend.

All the i.c.s. are soldered direct to the board. This prevents them working loose, and problems arising from oxidation. Be careful to ensure that all the i.c.s. are in the right place and the right way round before committing yourself to soldering. If you should happen to solder one in wrongly the best thing to do is carefully cut off the legs close to the i.c., and remove each leg with snipe-nose pliers and iron. Trying to remove the chip to use it again will almost

certainly overheat it, resulting at best in an unreliable device. When all the components have been fitted and checked the connecting leads can be fitted.

I found that the easiest way of completing the assembly was to colour-code the wires, noting which colour did what, and cutting off each to about a foot in length. This then allows the system to run up on the bench using a power supply, without having to first measure the cable runs.

One resistor, R18, has to be selected at test, and so cannot be fitted to the assembly just yet. To assist in selecting the value fit two pieces of tinned copper wire of about half inch in length in the position of R18.

When selecting later, the test resistors may be soldered to these leads, avoiding overheating and possible damage to the p.c.b. After the correct value has been ascertained, these pieces of wire are carefully removed and the resistor fitted in their place.

Don't forget to fit the two insulated jumpers to the underside of the p.c.b., one next to IC8, and the other from the emitter of TR1 to the negative side of C1.

TESTING

The equipment required for testing is as follows:

Bench power supply, 13V @500mA.
Multimeter, 20k ohm/V minimum, 20V range, and current, 20mA range, or the best you can manage.
Oscilloscope, single beam, or see text below.

Jumper-lead with croc-clips on each end,

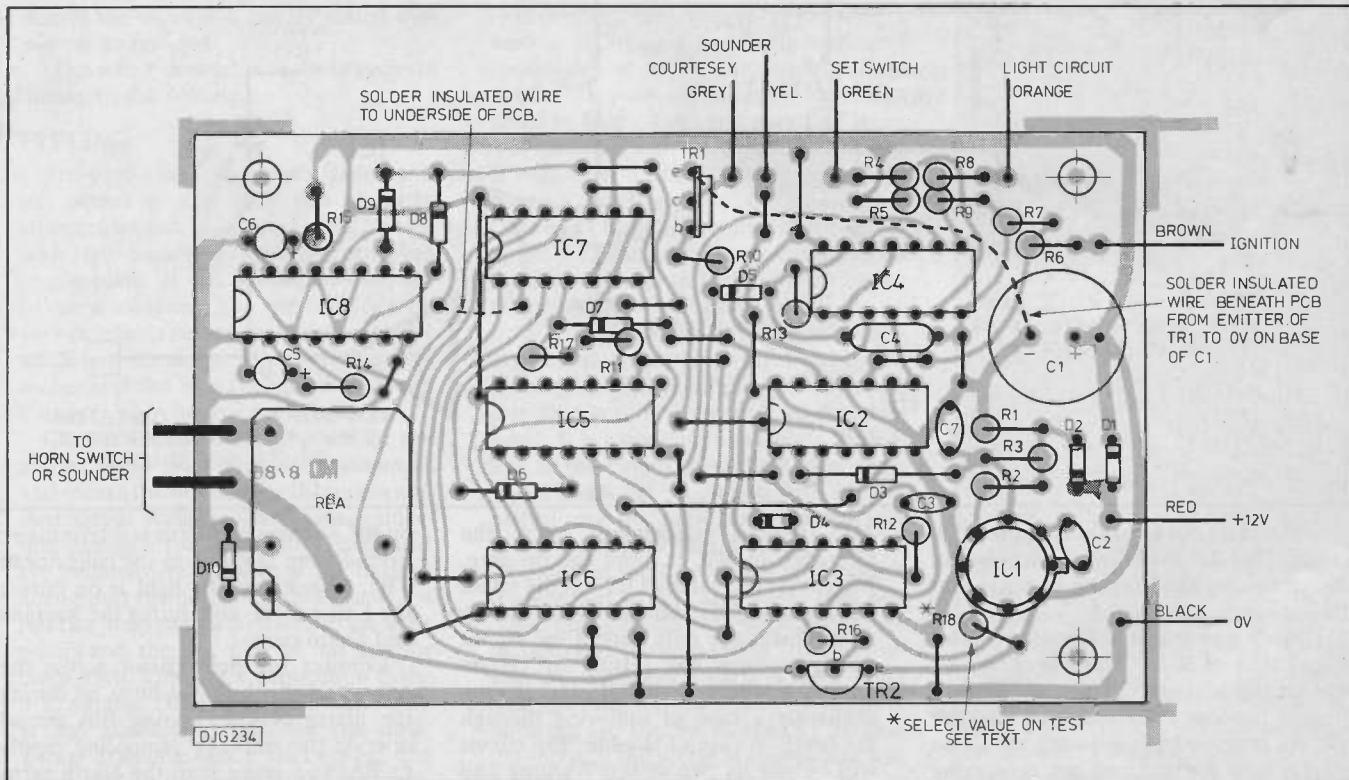

Fig.3. Details of the printed circuit board

VIGILANTE CAR ALARM

about a foot in length.

12V bulb in holder, but rated at about 6 watts

Selection of resistors from 100Ω to 1k.

Connect up the board via the ammeter, and check that the total current drawn does not exceed 10mA, and there are no overheating components. Disconnect the current meter and reconnect it to the supply. Check that the voltage present at the anode of D2 is V+ less 5.6V, about 7V.

Power down and solder a resistor of about 2M2 on the temporary connections for R18. Then connect the jumper lead to V+ and the cathodes of diodes D8&9. Connect the scope to pin 6 of the op amp, ensuring that the probe does not short out adjacent legs. Apply power and monitor the scope.

The output of IC1 must be high. If it is not, try reducing the value of R18 to

1M. If you cannot get this stage to work properly, go back and check the voltage across D2, the orientation of IC1, and all the associated components.

for this to work correctly enough time must be allowed between 'dab-ons' to enable C7 to charge to its full potential. So give it about a couple of seconds.

What you are now doing is selecting the amount of offset to feed in to the op amp, by changing the value of R18 so that the monitor just switches when a load resistor of about 330Ω is touched onto the supply leads. By altering the value of R18 and the test resistor the sensitivity of the monitor should be such that it will trigger the output when a genuine alarm condition occurs, and will be quite insensitive to false alarms. When the value for R18 is set, the temporary wire connections can be removed, and R18 soldered into place.

It is not a bad idea to check the result after it has been fitted into place.

In several tests carried out the value for R18 was found to lie in the 1M to C3 will also change the timing of the whole circuit. In this way you may tailor the Exit time to individual needs. For example, a disabled person may require a lot longer to switch off the alarm or to exit, and this can be taken into account. The time that the alarm will sound for, however, will remain at three times that of the Exit. Of course there is no reason why the experienced constructor should not do some track cutting under the timer...

The values suggested for R13 and C4 will give an output frequency to the piezo of about 3.5kHz. Since individual piezos tend to differ in their characteristics, it would be as well to check the sound level obtained at test, and play

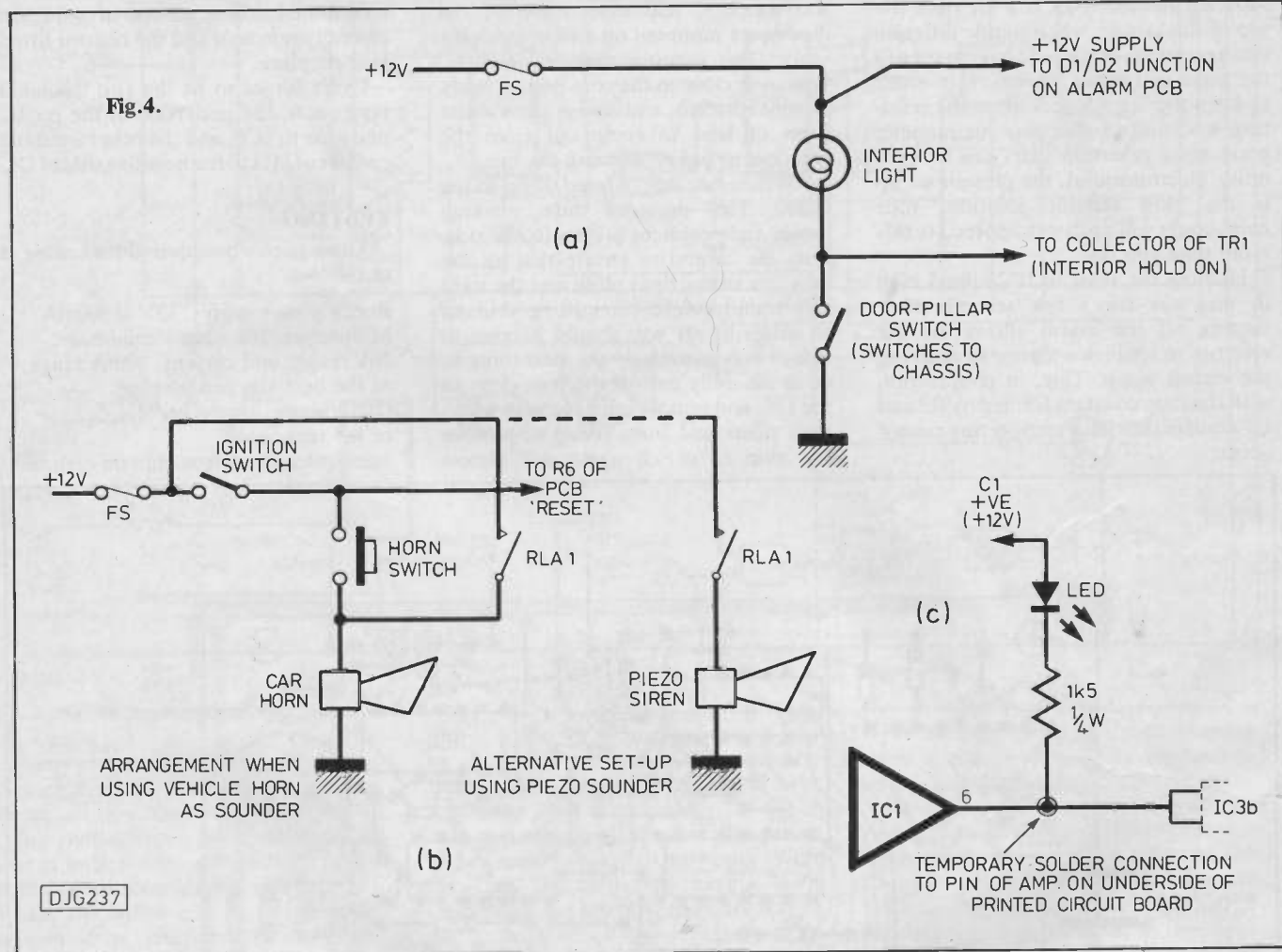

If you do not have a scope, the l.e.d. circuit (Fig.4.c.) will give enough of an indication for the purpose of setting up the op amp.

Having arrived at a situation where the output of IC1 is high, keeping one eye on the output, load the supply with one of the low value resistors, say, the 1k. By progressively reducing the value of the load resistor you can determine the point at which the output of the op amp no longer changes. Don't forget that

3M3 regions, depending upon the tolerance of R2, R3 and the op amp. Increasing the value of C7 has the effect of increasing the sensitivity of the op amp. This is the only part of the circuit which requires any setting up. Hereafter the whole is digital, and is consequently a case of following through the levels in case of trouble. The circuit will output its two states, Warning and Alarm, in a 1:3 relationship.

Changing the value of either R12 or

on the warning oscillator is intermittent. Connect the 12V bulb to the collector of TR1. Check that the light is on during the Exit period, and during the warning and alarm period.

Connect the bulb circuit across the relay, and check that it turns on during the alarm period. During this period operate the reset, by jumpering supply to R6, and make sure the alarm turns off immediately.

Apply a couple of blobs of silicon

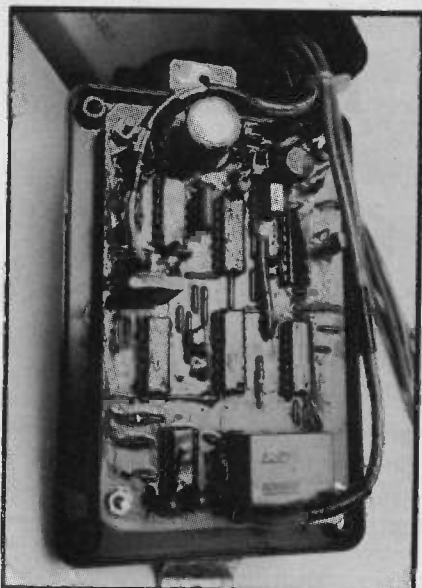

with values to get the maximum.

Connect the jumper to supply, and to R8, simulating the "lights on" condition. Check that when the circuit is switched rubber to either side of TR1, to prevent it vibrating and possibly being damaged. Tie the wiring into neat cableforms, not so much for looks as for support, and spray the whole assembly with protective lacquer. If you haven't any lacquer, one of the moisture repellent sprays will do. Mount the p.c.b. onto the lid of the box, using plastic stand-offs and shakeproofs and seal the nuts in place with more blobs of silicon to prevent them working loose. Feed the cableform through the grommet, and assemble the box. When all is in place the space left round the wires also can be sealed with silicon compound.

The whole assembly is then ready for fitting to the vehicle.

FITTING

Provided the flying leads have been left about a foot long this is fairly straightforward, requiring a set of crimps with butt connectors, spades, and eyes to complete. If you should be tempted to use a soldering iron out of doors, be very careful. The only safe way is to put an Earth Leakage Trip between the mains and the iron, but if possible use crimps.

Choose a well protected place for the alarm, away from heat and dampness, and secure the box using self-tappers and shakeproof washers. The earth connection can be made here also. Disconnect the negative (earth) side of the battery. Using butt connectors, run wires to the interior lamp switch mounted in the door pillar, and the live side of the interior lamp itself. This latter connection is the +12 supply. Drill out a hole and fit S1 in any convenient spot on the dash. Using a double-sided sticky pad, the piezo can be mounted under the dash. Connect these to the main alarm. Take both of their return lines to the chassis.

Connect the switched side of the ignition and the live side of the light circuit to the appropriate wires to the alarm. Reconnect the battery, and momentarily turn on the ignition, resetting all the flip flops.

Carry out a quick check of the system, particular that operating the ignition switch will turn the system off! Provided all is well, using heavy (15A) cable connect up the alarm sounder. This may be either the vehicle horn or one of the low-current piezo sirens. Make sure that if you choose the piezo, it is self-contained siren, and not a horn requiring an a.c. input to drive it.

Whether or not you include the lights in the Bark mode is a matter of personal taste. In that case, a separate relay will have to be fitted in order to carry the current, although many modern cars already drive the lights through a relay, and it may be possible to plumb into this wiring.

Don't forget: in order for the alarm to work the interior light must turn on when the doors are opened! Most car manufacturers, or spares shops can supply extra door pillar switches, and these should be fitted to the rear doors in the case of a 4-door vehicle.

You will find that operating the lights with the alarm on will draw enough current to trigger the alarm and, in the author's case, turning on the radio does as well! Once the lights are on, the alarm should set and operate correctly. If it doesn't, then you've probably got the sensitivity set too high. Back to the test bench, and try reducing the value of R18.

Protecting the bonnet or boot is a matter of fitting a switch to each, and connecting it in to the interior light circuit. If your car already has them fitted to lights, then you may find these will draw enough to trigger the alarm. If not, then a little rewiring should do the trick. While you are carrying out your tests don't forget the sound of the alarm might be music to your ears, but is unlikely to be so to your neighbours, so take care when testing.

In some instances it might be necessary to fit an external reset switch, in place of the ignition. This is easily done provided you bear a couple of things in mind. It is a good idea to isolate the V+ line to the switch with a low value fuse, say, 250mA, in an in-line fuse holder, just in case the cable should accidentally short to earth. The switch must be mounted in such a place as to minimise the amount of dirt and water that will come into contact with it. It should be of the type recommended for use outside. As mentioned earlier, the system will operate automatically if desired. Shorting out the Set switch, S1, so that the input to the alarm is always low, will do this. Each time the ignition is switched off the Enable flip flop will be set. This particular option was found by

If the Bark device is the vehicle horn, the author to be a real pain. try to make sure that the wiring cannot easily be tampered with from the underside of the vehicle.

This completes the fitting, and now all you have to do is remember to set it, and to close the windows and lock the doors, and hopefully your pride and joy will remain so until it goes for that final run to the great scrapyard in the sky when you decide it should!

PT

COMPONENTS

RESISTORS

R1	2k2
R2,R3	22k (2 off)
R4,R6,R8	1k (3 off)
R5,R7,R9,R10,	10k (5 off)
R16	
R11,R17	47k (2 off)
R12	82k
R13	120k
R14,R15	100k (2 off)
R18	see text

All resistors 1/4W, 5%

CAPACITORS

C1	470µ 16V
C2	100pF disc
C3,C7	0.47µ/50Vlayer (2 off)
C4	10n disc
C5,C6	10µ/16Vtantalum (2 off)

DIODES

D1	1N4001
D2	5V6 zener
D3,D4,D5,D6,	1N4148 (8 off)
D7,D8,D9	

SEMI CONDUCTORS

TR1	BD697 Darlington
TR2	2N5087 or equiv.
IC1	LM 301 op amp
IC2,IC7	4013 dual flip flop (2 off)
IC3,IC4	4093 quad NAND Schmit (2 off)
IC5	4020 counter
IC6	4081 quad AND
IC8	4528/4538 dual monostable

MISCELLANEOUS

Piezo Sounder Maplin FM59P,
S1 push to make sub-min, RLA1
12V, s.p.c.o. rated at least 10A (eg.
Maplin YX97F), case (Verobox 303),
Grommet, nuts, bolts, shakeproofs,
wire, crimp connectors, turret tags,
en.cu.wire, insulating sleeving,
cable ties, mounting bracket, self
tapping screws, p.c.b., etc.

SWITCH MODE PSU DESIGN

BY ROBERT PENFOLD

The fundamentals of switch mode operation

Switch mode power supplies have certain characteristics which make them well worth the extra trouble of designing for some applications.

SWITCH mode power supplies are one of those things that most electronics enthusiasts will have heard of, and many will have a vague idea of the principles involved, but relatively few people seem to be fully conversant with the basics of their design and operation. In view of the fact that power supplies of this type are now quite commonplace in commercial equipment, it is perhaps surprising that so few have so far appeared in designs for the home constructor. No doubt the situation will change in due course as the techniques and the technology becomes widely understood. Designing a switch mode power supply is certainly a good deal less straightforward than producing a circuit for a conventional type having a comparable specification, but there are definite advantages to the switched mode approach.

SWITCHED MODE BASICS

It would perhaps be as well to start with the basics, and to explain just what is meant by a switched mode power supply. There are actually several different types of switching power supply, and variations on each of these. Some are intended for voltage step-up or negative supply generation, others are for use as more efficient replacements for conventional regulators. We will start by considering the latter.

Consider the block diagram of Fig.1. which is for a conventional high quality power supply having a linear mode output device. This is based on an "error" amplifier, which is really just a differential amplifier, and in practice is often an operational amplifier such as the 741C. The non-inverting input of the device is fed with a well stabilised reference voltage which would typically be obtained from a zener diode fed from a constant current source. The precise reference voltage is not that important, except in that the output voltage of the power supply can not be set at a figure which is less than the reference potential. Consequently the reference

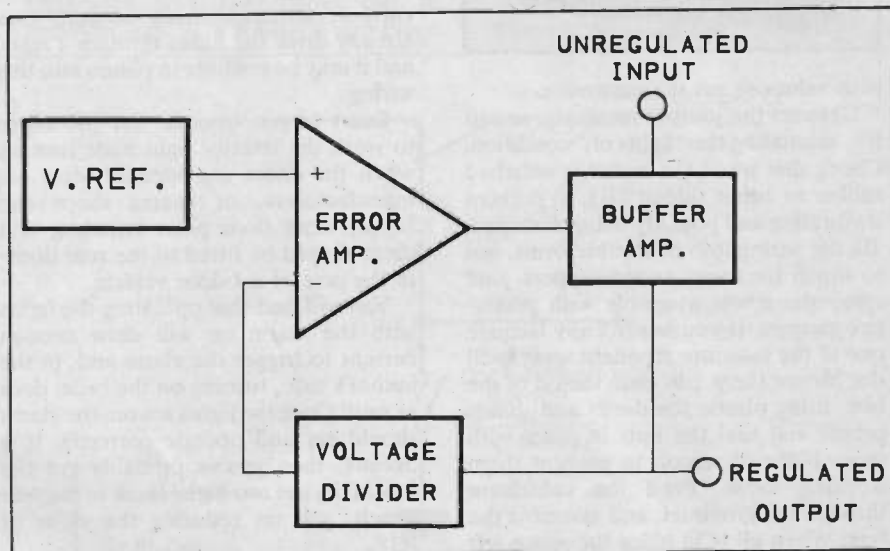

Fig.1. Block diagram for a conventional series regulator.

voltage is often quite low at around 2 volts.

The output of the amplifier feeds the input of a buffer amplifier which enables high output currents to be supplied. If quite low currents are required the buffer stage can be dispensed with and the output is then taken direct from the error amplifier. The output of the supply is coupled to the inverting input of the amplifier via a potential divider circuit, and this gives what is really a conventional negative feedback arrangement with the amplifier operating in the non-inverting mode. With the output coupled directly back to the inverting input there is 100% negative feedback, the amplifier has unity voltage gain, and the output voltage is equal to the reference potential. Using a potential divider in the feedback network introduces voltage gain, and the output voltage is boosted. The feedback is simply maintaining the inverting input at the same voltage as the reference level at the non-inverting input, and in doing so it stabilises the output at this level, or some multiple of it. Note that the feedback is taken from the output of the buffer stage and not

the error amplifier, so that the feedback compensates for any changes in the output voltage due to variations in the loading on the buffer stage. In fact some high quality bench power supply units have a feedback input so that the feedback can be taken via the non-earthly output lead, so as to compensate for any slight losses through the lead.

With a conventional series regulator the output voltage is controlled by biasing the output device more or less heavily, as necessary, in order to maintain a constant output voltage. With a switching regulator the output device is either biased hard into conduction or is fully switched off, and is only in an intermediate state during the short transition between these two states. The output from the buffer stage is therefore a series of pulses, and it is the average output voltage that is being stabilised by the circuit. This may seem a bit useless on the face of it, but in order to give a well smoothed output from the pulse signal it is merely necessary to add a lowpass filter at the output. The output frequency is generally quite high at about 100 to 200kHz, and obtaining a low ripple output is not very difficult.

DESIGN FEATURE

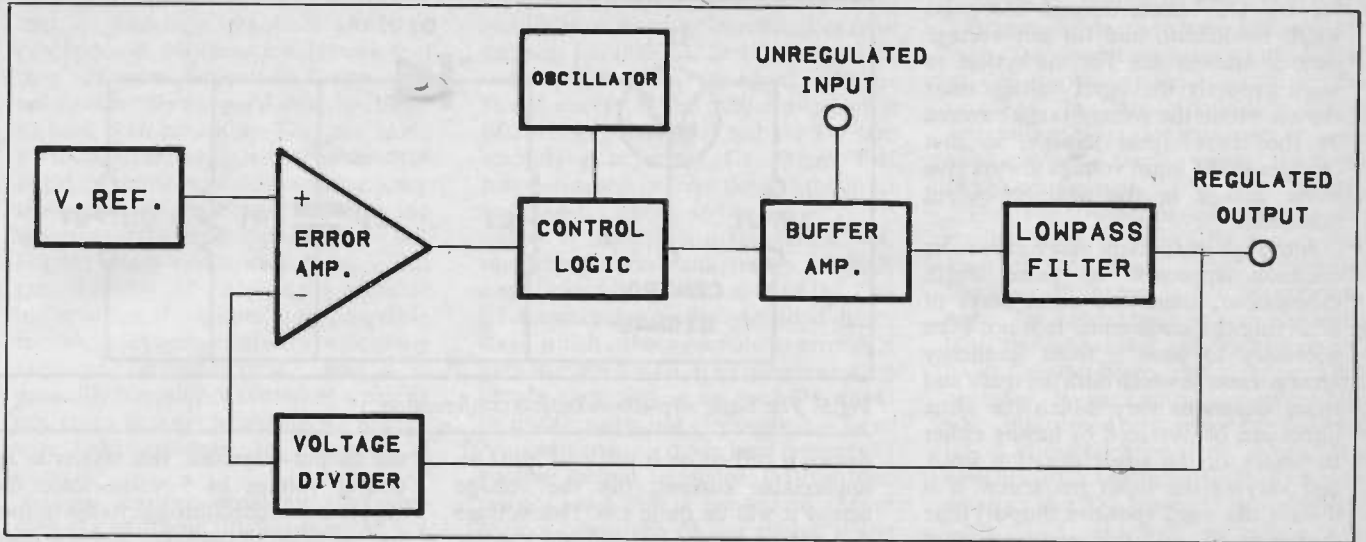

Fig.2. The basic arrangements for a switched mode PSU.

If we look now at the switch mode power supply block diagram of Fig.2., this is very much the same as the linear version, but a control logic circuit has been interposed between the error amplifier and the buffer stage, and a lowpass filter has been added at the output. The negative feedback must, of course, be taken after the lowpass filter and not from the output of the buffer amplifier. An oscillator feeding into the control logic circuit controls the output frequency.

There are any number of ways that the mark-space ratio of the output signal can be controlled to give the required average DC output voltage, and some methods are very much more complex than others. The classic approach to pulse width modulation (p.w.m.) is the arrangement outlined in the block

diagram of Fig.3. This merely has the input voltage fed to the inverting input of a voltage comparator and a clock signal fed to the non-inverting input. It is essential to the operation of the circuit that the clock signal has a triangular waveform.

The waveform diagrams of Fig.4. illustrate the way in which this simple set up provides the pulse width modulation. In each pair of waveforms the upper one is the clock signal and the lower one is the pulse output signal. The two broken lines represent the input

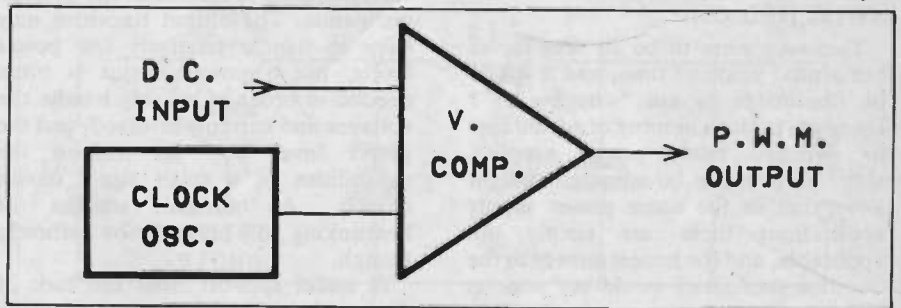

Fig.3. The classic method of pulse width modulation.

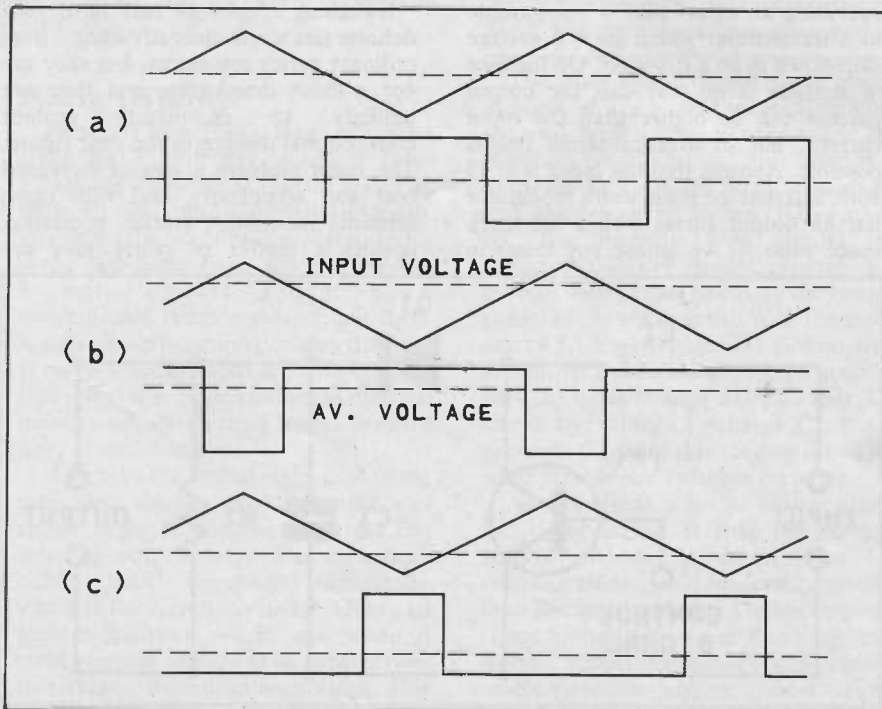

Fig.4. Pulse width modulator waveforms.

voltage and average output voltage. In (a) the input potential is half way between the peaks of the clock signal, and the output signal is therefore a squarewave with a 1:1 mark space ratio. The average output voltage is about half the supply potential.

In (b) the input level has been increased, and as a result of this the clock signal is higher than the input voltage for only about one quarter of the time. This gives an output signal with a 3:1 mark space ratio, and an average output potential of about 75% of the supply voltage. The input level in (c) has been decreased, and the clock signal is consequently at a higher level than the input signal for about 75% of the time, giving an output with a 1:3 mark space ratio, and an average voltage of a quarter of the supply voltage.

If carefully designed, a pulse width modulator can provide an average output voltage that is virtually identical to the input voltage over a wide range. For the present application this is not really necessary though, and the negative feedback action of the voltage regulator circuit will tend to compensate

for any DC offsets through the pulse width modulator, and for any voltage gain or attenuation. For the system to work properly the input voltage must remain within the voltage range covered by the clock signal though, so that changes in the input voltage always give some change in the average output potential.

Although this system may be the most common approach to pulse width modulation, there are other ways of achieving the same ends. It is not even necessary to have a fixed frequency arrangement in which both the mark and space durations vary. Much the same effect can be obtained by having either the mark or the space duration fixed, and varying the input frequency. It is usually the mark (positive output) time that is fixed, and the average output voltage is increased by raising the input frequency so that the output pulses become bunched up, or reduced by decreasing the frequency so that they are more spread out. This arrangement is basically just a voltage controlled oscillator (v.c.o.) feeding a non-retriggerable monostable multivibrator.

SWITCHED ON

This may seem to be all-very clever but a total waste of time, and it would be reasonable to ask "why bother"? There are in fact a number of advantages to switched mode power supplies, although it has to be admitted straight away that in the some power supply applications these are simply not applicable, and the honest answer to the question sometimes would be "none at all".

One advantage of switch mode power supplies, and the one which often makes them the most attractive proposition for use where a variety of different supply voltages are required, is their ability to provide a wide range of output voltages from a given input potential. With a normal series regulator the output voltage can only be less than the input voltage as the circuit functions by providing a variable voltage drop between the unregulated input and the regulated output. A switching regulator can operate in a comparable mode, but it can also provide a voltage step-up, and it can even generate a negative supply from a positive input (or vice versa). This is a topic that will pursue in more detail shortly.

The other main advantage of switching regulators is their high efficiency. The fundamental reason for this is that the switching transistor is, by the nature of things, normally either switched hard on or fully switched off; and in neither state does it dissipate a great deal of power. In fact there is no significant dissipation in the device when it is switched off as although the voltage across it may be quite high, the current flow is extremely low indeed. When the

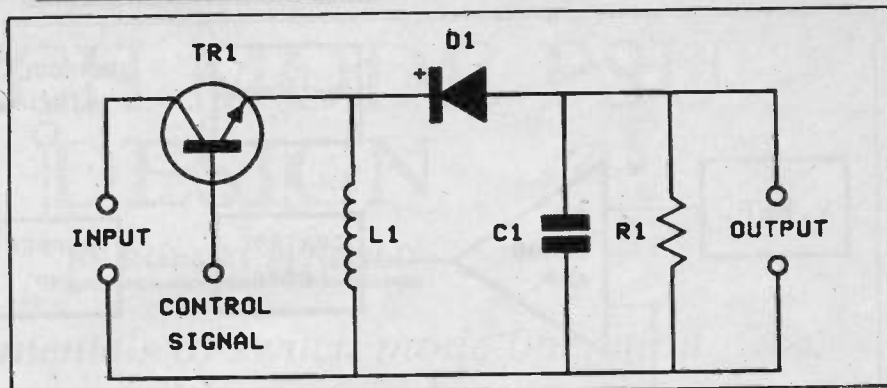

Fig.5. The basic step-down output configuration

device is turned on it will pass quite an appreciable current, but the voltage across it will be quite low. This voltage will not be totally insignificant though, and would typically be a volt or so. The power dissipated by the device during the on period could therefore be a few watts if output currents of a few amps are involved, although things are mitigated somewhat overall by the fact that the device may well be switched off for around 50% of the time, giving a corresponding reduction in the average dissipation. The output transistor may have to handle relatively low power levels, but a power device is often needed in order to reliably handle the voltages and currents involved, and the power level may be beyond the capabilities of a small signal device anyway. A minimal amount of heatsinking will normally be sufficient though.

A useful spin-off from the lack of dissipation is that the circuit can provide a low output voltage from a relatively high voltage source very efficiently, providing an effect that is comparable to a transformer which gives a voltage step-down in an a.c. supply. On the face of it there is no way that the output current can be higher than the input current, but in average terms this is possible. Assume that the input is at 15 volts and that the pulse width modulator has an output signal with a 1:2 mark space ratio. If we ignore any losses in

the output transistor, this results in an output voltage of 5 volts, since the supply is switched through to the output for one third of the time, and one third of 15 volts is 5 volts. If the output current is (say) 600 milliamps, then the input current is pulsed at the same figure, but with a 1:2 mark space ratio this gives an average input current of 200 milliamps. The filter at the output integrates 15 volts 600 milliamps pulses into reasonably steady 5 volts at 600 milliamps, and a smoothing capacitor at the input can similarly convert the input signal from pulses to an almost constant 200 milliamps.

Of course, calculations of the type provided above are about as valid in practice as theoretical transformer calculations. In practice there will be losses in the switching device and the output filter, and unless there is a fairly substantial difference between the input and output voltages the input current may still exceed the output current.

SWITCHED OFF

Switching regulators may have very definite and worthwhile advantages over ordinary series regulators, but they are not without drawbacks, and they are unlikely to completely replace conventional designs in the near future. The main problem is one of increased cost and complexity, and with three terminal monolithic voltage regulators costing a matter of pence they are

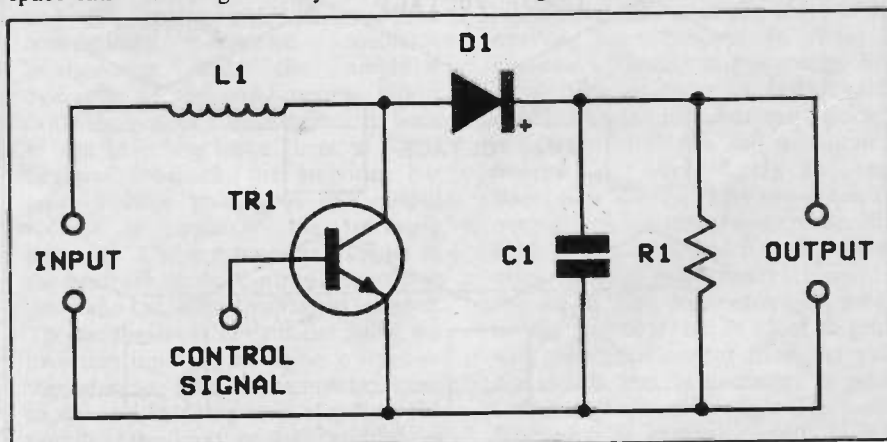

Fig.6. The basic booster or step-up output configuration.

normally a much more sensible choice than a switching regulator. Another problem with switching regulators is that they are more difficult to design, and unless carefully designed would be likely to have poor reliability. They are likely to be somewhat less reliable than ordinary series regulators anyway, since they generally have more circuitry and therefore have more opportunity to fail. For the home constructor there is also the difficulty of obtaining a suitable inductor for the output stage. Suitable ready-made components are not exactly available "off the shelf", and it is generally a matter of obtaining a pair of pot cores and some enamelled copper wire and winding the component oneself.

There are also problems associated with the switching process that can not be totally ignored. The obvious problem is that of obtaining a really low noise output. This may not always be necessary, especially bearing in mind that they will be predominantly at high frequencies, and will consequently tend to be less of a problem than the normal mains "hum". It could cause difficulties in some applications though, such as in radio receivers and test gear applications. While it is not impossible to obtain really low levels of output noise it is generally a little more difficult than with a conventional regulator with its inherently low noise output.

Another problem associated with the switching is that of radio frequency interference being radiated. To minimise this there should only be short leads in the wiring to the output filter and output stage, and where possible only short output leads should be used. Overall screening of the supply and using a type of inductor that radiates a weak field also helps.

OUTPUT STAGES

There are three basic types of output stage for a switching regulator (plus numerous variations on these), and these provide totally different functions. The only type we have considered so far is the step-down type, which is used as a more efficient version of a conventional series regulator, but there is also an output configuration that will provide a voltage step-up, and another that gives an inversion (which in this case means a negative supply from a positive one, or vice versa).

If we take the output stage used in the step-down configuration first, this is as shown in Fig.5. Circuits which use this type of output stage are sometimes called "buck" regulators incidentally, which is the American name. TR1 is an emitter follower switch, and when it comes on, the voltage at its emitter rises to virtually the full input voltage. This gives a voltage across L1 which is almost equal to the difference between the

input and output voltages, and this results in a steadily increasing current through L1, into C1, and the load. This continues until TR1 turns off, and the stored energy in the inductor (which is of reverse polarity) is fed via D1 into smoothing capacitor C1. When TR1 turns on again, current flows through L1 and into C1 again, and so on.

This is really just a standard L - C smoothing circuit and things are only complicated by the inclusion of D1. This is necessary due to the one-sided driver stage which otherwise fails to provide a path to earth for L1. If a complementary output stage was to be used D1 would be unnecessary, but obviously it is more economic to use a diode here rather than another output transistor. R1 is a load resistor, and this is needed to ensure correct operation of the circuit if the output is left open circuit, just the same as with a conventional series regulator. Normally it is not necessary to include a load resistor as the potential divider in the negative feedback network will provide a suitable resistance across the output.

satisfactory results in this application. The inductor needs to have a reasonably high Q value and it must work efficiently at the (probably) quite high currents involved in this application. This generally means using a pot core or some similar type of ferrite core as the basis of the component.

The basic inverter or "buckboost" configuration is shown in the circuit diagram of Fig.7. The American "buckboost" name is an appropriate one, as it has features in common with both the step-down and boost circuits. As in the step-down configuration, TR1 operates as an emitter follower, but when it is turned on it drives current into L1, as in the booster circuit. When TR1 switches off, L1 again produces a reverse voltage, and D1 conducts this into C1. When TR1 switches on again D1 prevents a positive charge from being fed from the input to C1 by way of TR1. Thus a reverse polarity supply is produced across C1.

It is assumed here that a negative output signal is being generated from a positive input, but the opposite type of

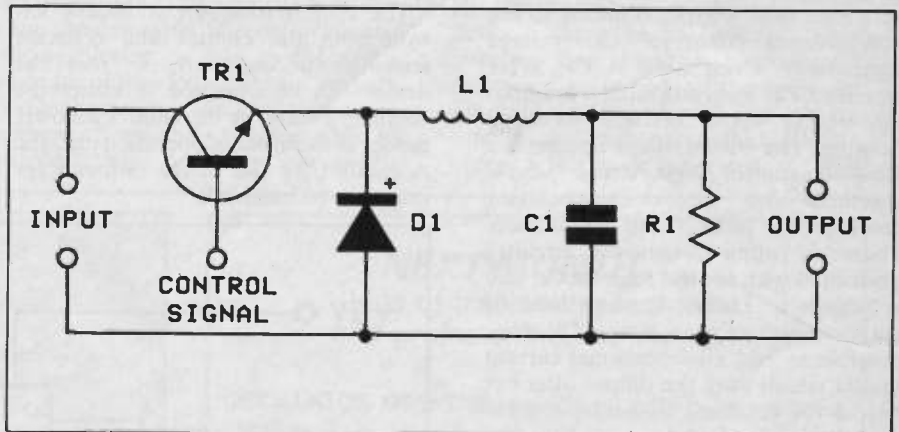

Fig.7. The basic buckboost output configuration.

The basic boost output stage circuit appears in Fig.6. In this configuration the switching transistor operates in the common emitter mode, and when it is switched on a current flows through L1 and it stores energy. When TR1 switches off, the magnetic field around the inductor collapses rapidly, generating a reverse voltage and releasing the charge stored in the component. With the input end of L1 negative and D1 end positive, the output from L1 is connected in series with the input voltage and adds to it. D1 allows this voltage to charge C1, but it prevents C1 from discharging into TR1 when this device switches on again.

An important point to realise about the boost circuit is that the reverse voltage generated across L1 when TR1 switches off can be considerably greater than the input voltage. Thus the circuit is not limited to voltage doubling, and with an apposite inductor it can provide a considerable voltage boost. Note however, that a simple ferrite cored choke for RF use is unlikely to give

conversion can be obtained merely by reversing the input polarity, changing TR1 to a pnp device, and reversing D1.

Like the booster circuit, the use of an efficient inductor is essential if this type of output stage is to operate well.

SWITCHING ICs

Switch mode power supplies can, and sometimes are, produced entirely from discrete components, but there are many integrated circuits for switching power supply applications, and these make things very much easier. We will not consider any practical devices here as this article is concerned more with the fundamentals of operation than practical circuits. Also, some switched mode power supplies are featured in a separate article and there is no point in duplicating information provided in the other article. However, looking at things in broad terms, most switch mode power supplies have an internal arrangement along the lines of the block diagram shown in Fig.8.

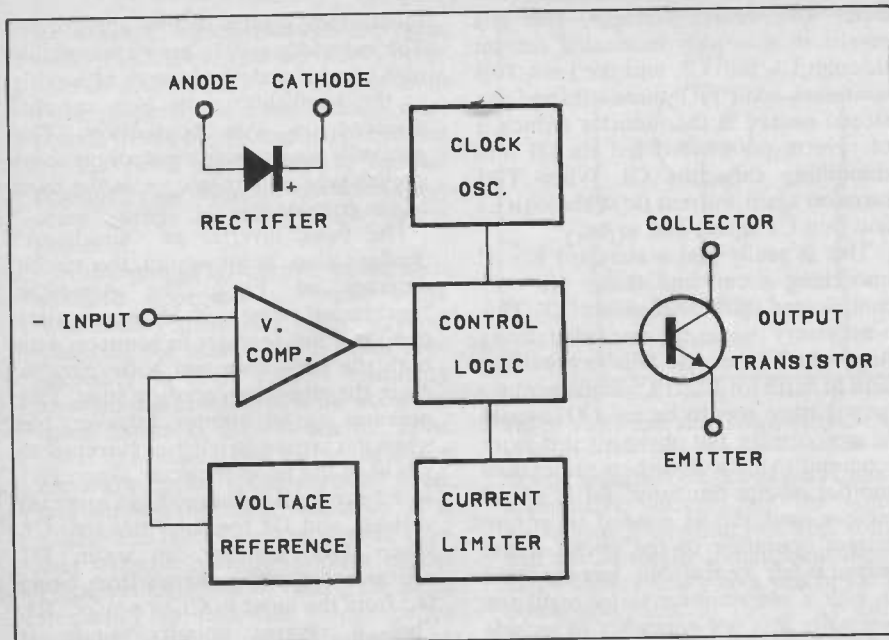

Fig.8. Typical arrangement for a switching mode power supply chip.

An internal reference voltage generator, which would normally be a very high quality type, connects to the non-inverting input of the voltage comparator which acts as the error amplifier. The inverting input is fed from the output via a discrete feedback network. The output of the comparator feeds a control logic circuit which, together with the clock oscillator provides the pulse width modulation. There is often additional circuitry associated with control logic block, and a "standard" feature is some form of current limiting circuit. It would be quite possible to add a conventional current limiter circuit after the output filter but before the feedback take-off point (so that the feedback compensated for any voltage drop through the limited circuit). This would be an inefficient way of doing things though, as the pass transistor in the limiter would need to be a power type, and would dissipate quite a lot of power under overload conditions. It is therefore more normal for the current limiter to reduce the output voltage by controlling the output waveform via the pulse width modulator. A discrete resistor in the supply path is used to set the limit current, and this normally operates in conjunction with an operational amplifier instead of the conventional current limit type circuit where a transistor is turned on when the voltage across the resistor reaches about 0.65 volts. The advantage of using an operational amplifier or some similar arrangement is that it can operate with a much lower activation voltage of typically only about one tenth of that associated with conventional limiter circuits. This avoids the need for a high wattage resistor and helps to give the circuit good efficiency. In fact this feature has the same advantages when applied to an ordinary series regulator,

and is incorporated in some of the more recent designs for these.

The output transistor is usually left with both the emitter and collector terminals unconnected, so that the device can be operated in either the common emitter or the emitter follower mode, as the mode of operation dictates. A rectifier for use in the output stage may also be included.

like the types described above, but they have the advantage of providing an output which is isolated from the input. A similar arrangement is used in some mains power supplies where the mains supply is converted to a DC signal, and then chopped at high speed and fed to an isolation transformer. This system may not seem to have a great deal to recommend it, but the main point in its favour is that the relatively high operating frequency of the signal fed to the transformer enables it to be much more efficient than an ordinary mains transformer, so that the power supply can be very compact and will run comparatively cool.

A more common type of DC to DC converter these days is the transformerless and inductorless type. These are sometimes just an oscillator feeding a rectifier and smoothing circuit which is either configured to add the output of the smoothing circuit to the input supply so as to give a boost, or to generate a negative supply. An alternative type uses semiconductor switches to give a voltage boost or negative output. Probably the best known device for use in this type of supply is the ICL7660. This operates in the basic circuit of Fig.9., but Fig.10. gives a better idea of how it generates a negative supply rail.

S1 is an electronic DPDT switch that is switched continuously from one

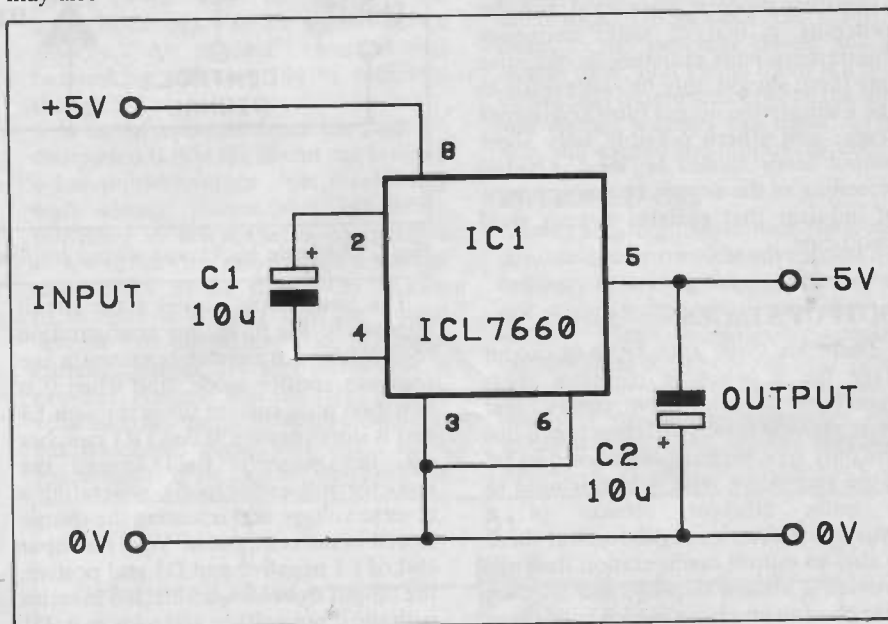

Fig.9. Using the ICL 7660 as a negative supply rail generator.

OTHER TYPES

The three types of switching regulator described above are the standard types, but there are totally different types of switch power mode supply. A type of switching power supply which was at one time probably the most common, but which is relatively rare these days, is the transformer type. Some of these are for use in DC to DC converter applications,

position to the other by an oscillator which operates at a frequency of around 10kHz. When the switch is in the position shown in Fig.10. it connects Ca across the positive (input) supply, and it therefore charges to +5 volts. When S1 is set to the opposite position, Ca discharges into Cb until the charge voltage on the two capacitors is equal. The basic action of the circuit is therefore to transfer power from the positive

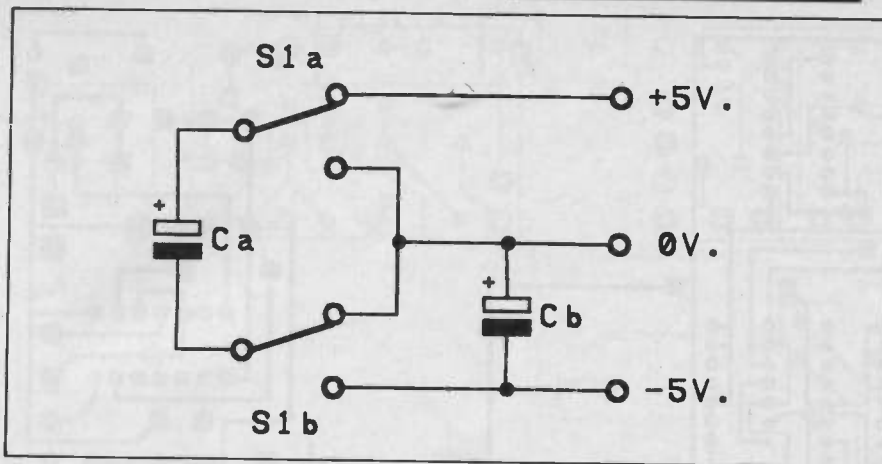

Fig.10. The ICL 7660's basic methods of operation

supply rail to the negative output by repeatedly charging C_a from the former and discharging it into the latter. Note that the switching is arranged so that C_a connects to the negative output rail with the correct polarity. C_1 and C_2 of Fig.9 are the equivalents of C_a and C_b of Fig.10. Switching supplies which use this charge transfer process are called "charge pump" voltage converters.

This basic system can be made to operate in reverse, and if the negative supply rail is used as an input a positive output will be produced on the positive supply rail. The ICL7660 is not designed

for use in this manner though, and should not be driven in this way. This basic system can be modified to provide voltage boosting, or inverting with an output voltage greater than the input potential. It is a relatively crude way of doing things though, and the output tends to have a high ripple level and poor regulation. The high ripple is due to the simple output filtering, while the poor regulation, is due to the series resistance of the electronic switches with no feedback and control system to compensate for this. It is possible to overcome these problems, but at the

expense of reduced efficiency and increased complexity. Supply circuits of this type are generally only used where poor regulation and a fairly high ripple level are not important. They are also mainly restricted to low current applications where the voltage drop through the switches will not be sufficient to seriously deplete the output voltage. The ICL7660 has a typical series resistance of 70R, giving a voltage drop of 0.07 volts per milliamp of output current (e.g. 4.65 volts with an output current of 5 milliamps).

CONCLUSION

Circuit designers generally try to avoid multiple supply rails wherever possible, but despite improvements in integrated circuits over the years there still seem to be few circuits of any complexity which operate off a single supply. Switch mode power supplies of one kind or another therefore seem likely to be in demand for some time to come, and a likely development is for more integrated circuits to have them built-in. This is already a feature of the MAX232C device, which is an RS232C serial interface line driver and receiver. It requires only a +5 volt supply, and generates its own +10 volt and -10 volt supplies to enable standard RS232C output levels to be generated. PE

BOOKMARK

The following books have recently been received:

Further Practical Electronics Calculations and Formulae. F.A. Wilson. Babani BP144. £4.95, Over 400 pages of excellent data, formulae and diagrams.

Electronic Circuits for Computer Control of Robots. R.A. Penfold. Babani BP179. £2.95. Another fascinating book from a most prolific writer. 92 pages of practical circuits and information regarding interfacing computers with mechanics.

Signal Processing Design Techniques. B. Rorabaugh. Tab Books. £29.95. An in-depth analog and digital filter circuit design guide, written especially for engineers, technicians, circuit designers and advanced hobbyists.

How To Use Special Purpose ICs. D.T. Horn. Tab Books. £15.30. Shows how to put the vast array of special purpose i.c.s to work in dozens of practical applications.

Computer Engineers Pocket Book. M. Tooley. Newnes. £8.95. An invaluable compendium of facts, figures, circuits and data indispensable to all involved with computers.

117 Practical IC Projects You Can Build. R.H. Warring and D.T. Horn. Tab Books. £9.80. Dozens of fully tested, ready-to-build circuits you can put together from readily available i.c.s.

Elementary Electricity and Electronics - Component by Component. M Horowitz. Tab Books. £15.30. A practical introduction to basic electronic concepts with emphasis on specific components and their usage.

Electronics - A Systems Approach. A. Johnson. Hodder and Stoughton. £5.95. A new book for GCSE electronics which adopts a practical approach to circuit design and the construction of electronic systems.

NEXT MONTH . . .

Lots of fascinating features
and projects lined up for you.

OSCILLATOR DESIGNS. A vibrant article on essential circuits.

SENSOR TECHNOLOGY. Hot off the press - thermal transducers in action.

ELECTRICAL SAFETY. Down to earth facts that you vitally need to know.

BIOFEEDBACK. Experimental electronics that could help you control yourself.

MICROFORUM. Double value for the ZX Spectrum - a circuit for two extra ports.

ADA. A versatile audio analogue-to-digital-to-analogue converter for sound effects.

FREQUENCY SYNTHESISERS. What they are, and how to use them in various applications.

ALL THIS, AND MORE -

*Including our regular top line features
of Spacewatch, Leading Edge, Industry Notebook,
New Products, and new exciting
experimental ideas.*

**DON'T MISS THE MAY ISSUE OF PE
ON SALE FRIDAY APRIL 3rd
AND STILL ONLY £1.25**

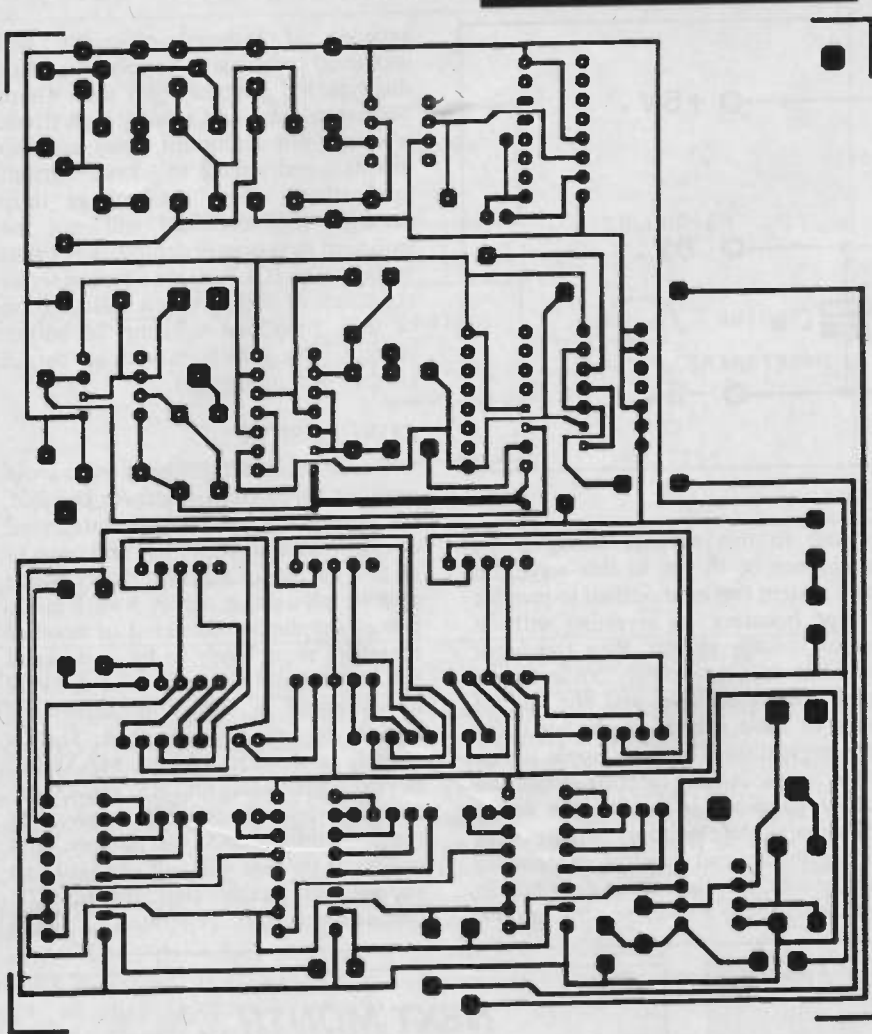

PE 138

PE 136

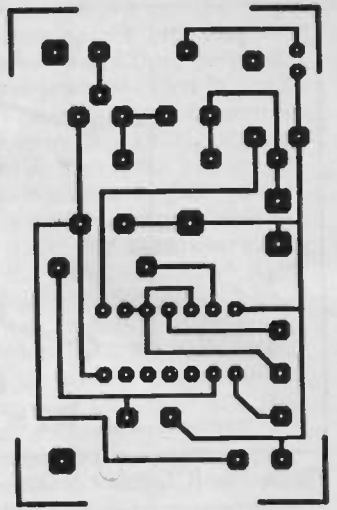

PE 137

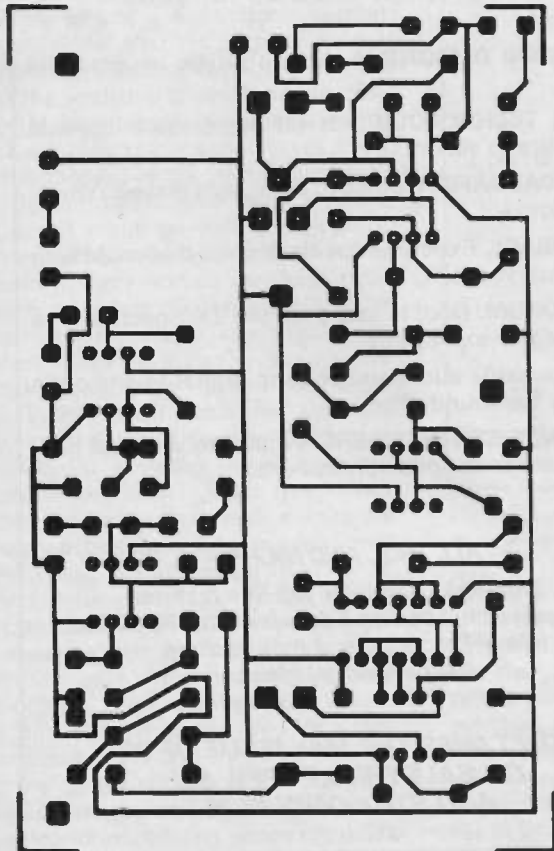
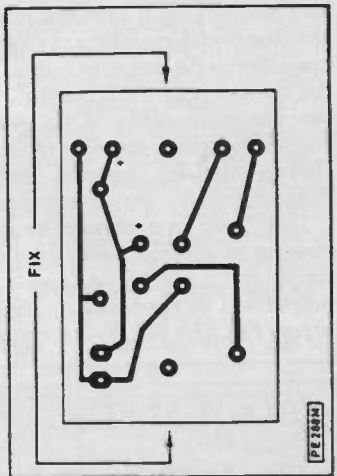

PE 135

PE 139

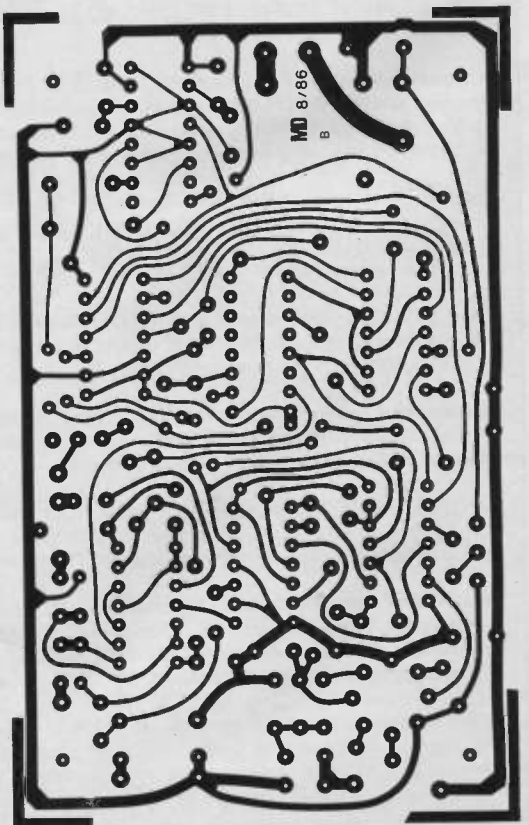

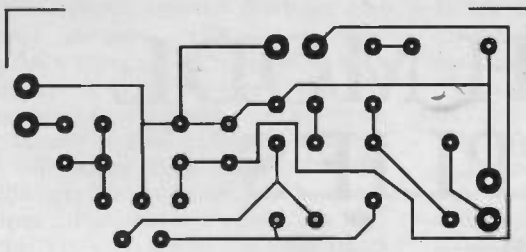

PE 144

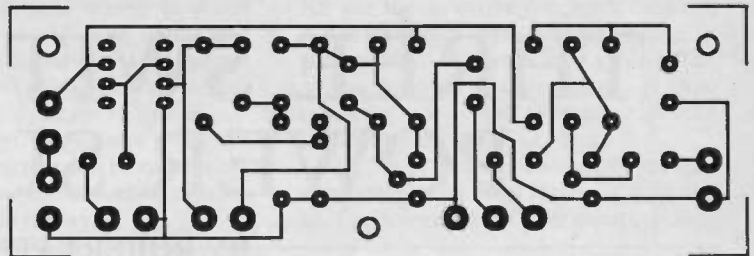

PE 143

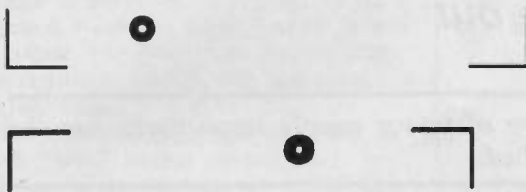

PE 142

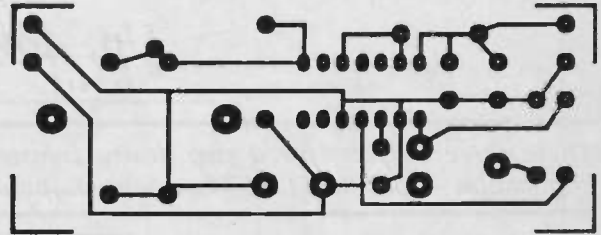

PE 141

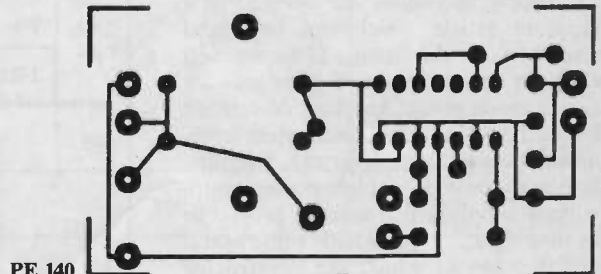

PE 140

P.C. TRACKS PE 135 TO PE 138 WERE HELD OVER FROM MARCH 1987 ISSUE.

FOR THE PE PCB SERVICE SEE PAGE 60.



BINARY CHOP – PUZZLE NO 1

TEST YOUR POWERS OF LOGICAL DEDUCTION AND WIN 12 MONTH'S SUBSCRIPTION TO PE!

Send your answer to this puzzle to:

Binary Chop No 1,
Practical Electronics,
Garway Road,
London W2 4NH

to reach us before 1st April 1987.

12 month's subscription to Practical Electronics will be awarded for the first three correct answers opened. The Editor's decision is final.

Answer in the June 1987 issue.

Look out for another mental challenge next month!

DECODE THIS 264 CHARACTER MESSAGE

THE SERIAL BINARY DATA CONVERTER OMITTED ALL LEADING ZEROS!
LETTERS A TO Z = ASCII 1 TO 26. NUMBERS 0 TO 9 = ASCII 48 TO 57.
COMMA = ASCII 44. FULL-STOP = ASCII 46. NO OTHER CODES ARE USED.

```

101001000101110110110100100011110010111011101111110001100101111010
010110010101111000111001100100011011010111011111000101011010010001111
011011010100111101100101100110010011111000110100100111011101010010001
01100101011100101011101101000011111001110011100110110010111001011110
1111010010001001110110011010010111110111000110100111111011010010011
11100110100100111011101101111111010110111100011001100100011101001100
10101001011110011010010001100001011101001011110011101111001001100111
01101111100011111101010010001011101101011110001011001010110110111001
0011001011101010010010111101001111001100010110100111111100011001011
110100101100101001111101001001110111001011110100111101001110110001011
100101101001011111110010111011110010101001000100110011110100101111
11011101001011111110101001111110110010011001110100101110101001101110
11110101110001010011011011110100100101011000010111010010111010011101
110001111111100111001111011111111100101001010111101001100110011011
0011101101100111001111111011011110011100110011000010001011100101011
10
    
```

THIS SHORT BINARY-CREATING PROGRAM MAY HELP

```

10 FOR A=1 TO 57:A$="":FOR B=0 TO 5:D=A AND (210)
20 A$=STR$(ABS(D>0))+A$:NEXTB:PRINT VAL(A$),NEXTA:PRINT
    
```

THREE SWITCH MODE POWER SUPPLIES

BY ROBERT PENFOLD

Up, down, inside – out

These three circuits, for a step down, booster and inverter type of power supply respectively, use the application – specific TL 497 i.c., whose operation is also described.

THE basics of switch mode power supply operation are covered in a separate article which can be found elsewhere in this issue. Here we will consider three practical designs for switch mode power supplies, one circuit for each of the three basic types (step-down, booster, and inverter). The idea is not to provide a high power multi-voltage supply which forms a project in its own right, but to provide some useful building blocks which the constructor can incorporate into his or her own designs.

There is some latitude as to the exact input and output voltages of the three designs, but the step-down regulator is intended to give a +5 volt output from a +12 volt input with a maximum output current of over 400 milliamps. The inverter is intended to provide a –5 volt output from a +5 volt output, and the maximum output current is about 150 milliamps. Finally, the booster yields an output of +12 volts from a +5 volt input, and the maximum output current is around 175 milliamps.

All three circuits are remarkably simple, and utilize the TL497 integrated circuit which is specifically designed for the present application. Unfortunately, switch mode regulator integrated circuits are considerably more expensive than conventional types such as the popular three and four terminal types, and they also need an inductor (which is also relatively expensive) in order to function properly. When deciding whether or not these modules are practical alternatives to more conventional designs this additional cost has to be weighed against the advantages of switch mode designs, and it will often not be possible to justify their use on economic grounds. However, under some circumstances switch mode power supplies are a very practical choice, and they also give added interest value to any project in which they are used.

TL497 BASICS

As all three circuits are based on the TL497 it would be as well to consider

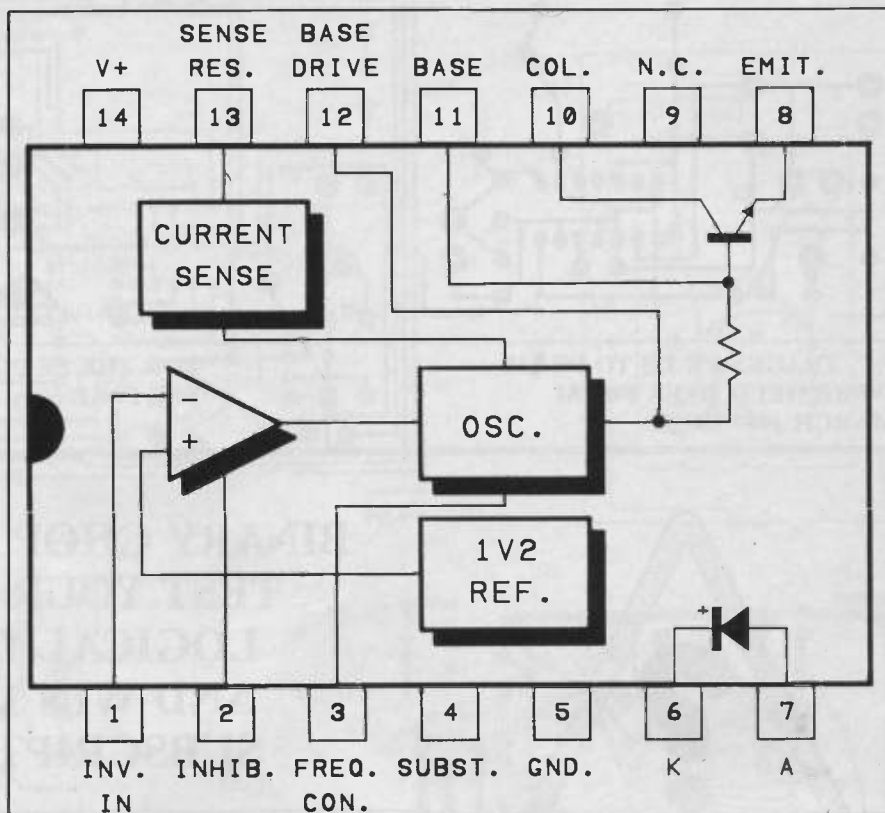

Fig.1. TL 497 internal arrangement and pinout details.

this device in some detail before progressing to a description of the power supply circuits themselves. The block diagram of Fig.1 shows the internal arrangement and pinout details for the TL497.

There is a rectifier available across pins 6 and 7 for use in the output stage, but note that the chip manufacturer recommends that an external component (such as a 1N4001) should be used for inverting mode circuits. This is presumably due to the diode being taken several volts negative of the 0 volt supply rail in this mode, and consequent problems with parasitic transistors or something of this ilk.

There is an internal reference voltage generator which has a nominal output potential of 1.2 volts, an actual output

voltage which is guaranteed to be not less than 1.08 volts and not greater than 1.32 volts. This voltage is not available externally, but is connected internally to the non-inverting input of the differential amplifier which acts as the error amplifier. The inverting input of the amplifier is made available at pin 1 so that it can be fed from a negative feedback network.

A current sensing circuit is built-in, and is used to reduce the output frequency in order to limit the input current to a preset level. Note that it is the input current and not the output current that is limited. Obviously by limiting the input current the output current is also prevented from exceeding a certain figure. However, unlike an ordinary series regulator where there is normally

little difference between the input and output currents, with a switching regulator there can be (and often is) a considerable difference between the two. This point is something that has to be kept firmly in mind, as does the fact that the maximum input current is 500 milliamps, but the maximum available output current is not necessarily as high as this. The input current limit value is set by a discrete resistor connected between pins 13 and 14, and the value of this resistor is equal to 0.5 divided by the required maximum input current. It is, of course, the peak input current that this resistor is determining, and not the average value.

The oscillator is a type which has a fixed "high" output period, and the average output voltage is varied by altering the frequency, which is effectively achieved by varying the "low" output period. The oscillator drives an output transistor which has its emitter and collector terminals unconnected and available at pins 8 and 10 respectively. This enables it to be used in any of the three standard types of output stage, but it can only handle output currents of up to 500 milliamps. For higher currents an external output stage is required, but in the circuits featured here the internal output stage suffices.

In operation the device is basically quite simple, and in some ways it is reminiscent of a relaxation oscillator. At switch-on the output voltage is zero, and this sends the output of the error amplifier fully positive so that a continuous stream of closely spaced pulses are produced by the oscillator. This quickly sends the output positive until it reaches the output voltage dictated by the feedback network. The output of the error amplifier then goes negative to reduce the average output voltage. If the output is loaded fairly heavily the circuit will settle down in standard pulse width modulation fashion to the point where the operating frequency of the oscillator is such that it maintains the required average output voltage. Things are rather different under very low loading, as the output filter and the load resistance have a relatively long time constant, and this tends to result in the output voltage building up to the point where the oscillator is cut off. Then, when the output voltage has subsided below its proper level, there is short burst of oscillation; the oscillator cuts off again, and so on. The output waveform is therefore short bursts of high frequency oscillations at a rate of perhaps only around 1Hz.

This may not seem to relate very well to classic pulse width modulation theory, since the average output voltage of the pulse signal and the smoothed output voltage are clearly not the same. The discrepancy is caused by the non-symmetrical nature of the output stage which effectively gives the smoothing

circuit an attack time which is much longer than the decay time unless the load across the output evens things up. This is all largely of academic importance, of course, but it does mean that if you check the output waveforms using an oscilloscope, they may not be quite what you would expect from standard pulse width modulation theory.

R3 are the negative feedback network which determines the output voltage. It is convenient to have R3 at a value of 1k2 as the nominal output voltage is then equal to the total resistance of the feedback network in kilohms.

The output voltage can not be set very accurately using fixed value resistors due to the tolerance of the resistors and,

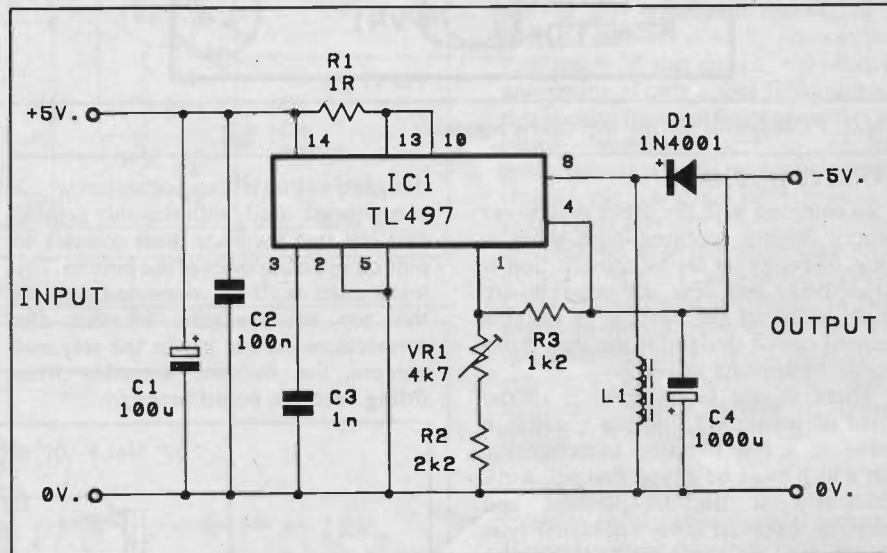

Fig.2. The step-down regulator circuit diagram.

STEP-DOWN CIRCUIT

The circuit diagram of the step-down regulator appears in Fig.2.

C1 and C2 provide input smoothing and decoupling, while R1 is the current limiting sense resistor. The latter sets the maximum input current at a nominal figure of 500 milliamps. As this is the peak input current rather than an average level it also limits the maximum output current at the same level in theory. In practice the circuit will not achieve 100% efficiency, and the maximum available output current will be, somewhat less, although still well over 400 milliamps. Of course, the average input current will be substantially less than the peak input current, except at very low output currents where the (typically) 11 milliamp current consumption of the TL497 and other losses seriously reduce the efficiency of the unit. On test the prototype had an input current of 115 milliamps from a 12 volt supply with the output voltage set at 5 volts and loaded to give an output current of 200 milliamps. This represents an input of 1.38 watts and an output of 1 watt, giving an efficiency of 72.5%. This compares with a figure of around 40% for a conventional series regulator used under the same conditions.

The output stage and rectifier of IC1 are connected in the standard step-down configuration, and L1 and C4 a conventional output filter. C3 is a timing capacitor for the oscillator, but it controls the "high" output pulse duration and not strictly speaking the output frequency of the oscillator. VR1, R2, and

more particularly, the tolerance of the internal voltage reference. VR1 is therefore used to trim the output voltage to precisely 5 volts. The actual adjustment range is from around 3.4 volts at minimum resistance to around 8.1 volts at maximum resistance. If you require (say) a 6 volt output instead of a 5 volt type, this can be accommodated simply by adjusting VR1 for the appropriate output voltage.

Although the input voltage is given as 12 volts, this can be anything from about 3 volts more than the output voltage up to the 15 volt absolute maximum input voltage rating of the TL497. The unit does not need to be fed with a well stabilised and smoothed supply of course, and in practice it would often be better to feed it from a raw d.c. supply rather than via a regulator, so that it does not increase the loading on the regulator. However, this is only possible if the peak input voltage will not exceed 15 volts.

There is a TTL compatible inhibit input at pin 2 of IC1, but this is not used in the circuits described here, and in each case it is tied to the 0 volt supply rail. In all three circuits there is a risk of relatively strong high frequency noise spikes on the output due to the lower efficiency of the output filter capacitor at these frequencies. These will often be of no consequence, or will be eliminated by decoupling capacitors in the main circuit anyway, but if necessary they can be removed by connecting a ceramic capacitor of about 10n across the supply output.

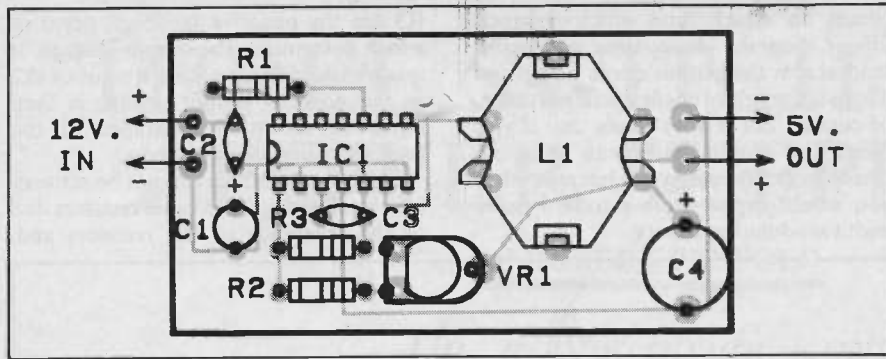

Fig.3. PCB layout for the step-down regulator

CONSTRUCTION

In common with the other two power supply designs featured here there is little difficulty as far as construction is concerned, and few components are used in any of the circuits. A suitable printed circuit design for the step-down regulator appears in Fig.3.

There is one slight problem in the form of inductor L1 which requires a value of a few hundred microhenries, but which must be a type that will work efficiently at the frequencies and currents involved here. The usual type of inductor for an application of this type is one based on a ferrite pot core, and although suitable ready made components do not seem to be available, it is not difficult to produce a suitable home wound component.

I used a pot core type RM8 having an inductance factor of 4100. A pair of cores is required, but they are normally sold as such. A bobbin is also needed, and this must be the correct 5 pin type if it is to fit onto the printed circuit board properly. A pair of mounting clamps are also needed, and these are normally sold singly. The winding consists of 30½ turns of 22 s.w.g. enamelled copper wire, and a 2oz reel of wire is sufficient to produce a number of these inductors.

Start by stripping about 3 millimetres of enamel insulation from the end of the wire (which may be easier using a sharp knife instead of wire strippers) and then tin the end of the wire and the top of one of the pins on the bobbin with solder. There should then be no problem in connecting these two together, after which the wire is taken in through the slit in the base of the bobbin so that the 30½ turns can be wound around it. There is no need to make the winding particularly neat, but do try to keep the wire fairly tight. In fact the whole assembly must be fixed together as tightly as possible and firmly held down on the board or the pulses of current through the inductor could result in a significant amount of noise being generated. When the correct number of turns have been added, take the wire out through the slit on the opposite side of the bobbin, cut it to length, strip the end of insulation, and connect it to a pin on that side of the bobbin. Note that the board has been

designed so that it does not matter which two pins are used, with the only proviso that the two leadouts must connect to pins on opposite sides of the bobbin. The leads must both be connected right at the top of the pins so that the connections do not get in the way and prevent the finished assembly from fitting onto the board properly.

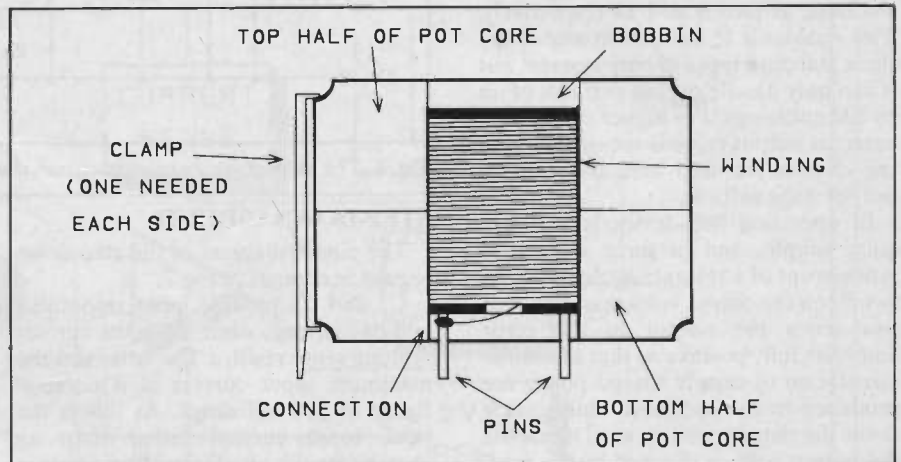

Fig.4. The pot core assembly.

To complete the unit the two halves of the core are placed in position and the two clamps are used to hold them together. They simply clip in place. The finished assembly should look something like the side view shown in Fig.4. Ferrite is not quite as brittle as egg shell, but it is not that much stronger. The finished inductor therefore needs to be treated with some respect and handled carefully. Dropping it onto a hard surface would almost certainly result in one of the cores smashing.

When first trying out this, or any of the designs featured in this article, it is advisable to include a multimeter (set to a d.c. current range with a full scale value of about 100 milliamps) in series with the input so that the input current can be monitored. With no loading on the output this should initially give a high reading which should almost immediately drop back to a reading of around 12 milliamps. The multimeter can then be set to a low d.c. voltage scale and connected across the output so that VR1 can be trimmed to give the correct output voltage.

BOOSTER CIRCUIT

The booster regulator circuit appears in Fig.5. This will not be described in detail as it basically just the step-down circuit with the output stage revamped into the standard booster configuration. Also, the negative feedback network has been modified to give an output adjustment range of approximately 5.9 to 15.9 volts so that the required 12 volt output level can be accommodated. The circuit actually seems to work quite well with any output voltage within this range. Although the TL497 is limited to an input potential of 15 volts, it can handle output voltages of up to 35 volts; this is not to say that output voltages of around 30 volts are necessarily a practical proposition as the input voltage and inductor may not be adequate to support them.

The circuit provides a voltage boost, but at the expense of a current step-down. Therefore the output current will be less than the input current, and with

the latter set at about 500 milliamps the theoretical maximum output current is just over 208 milliamps. In practice there are losses in the circuit which reduce efficiency and diminish the maximum output current. Around 170 to 180 milliamps should be available.

Construction of the unit is along similar lines to that of the step-down circuit, and the printed circuit design for the booster unit is given in Fig.6. The inductor is virtually the same as in the step-down circuit, but the number of turns is lower at 24½.

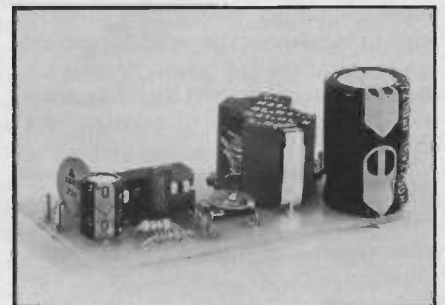

Step-down regulator

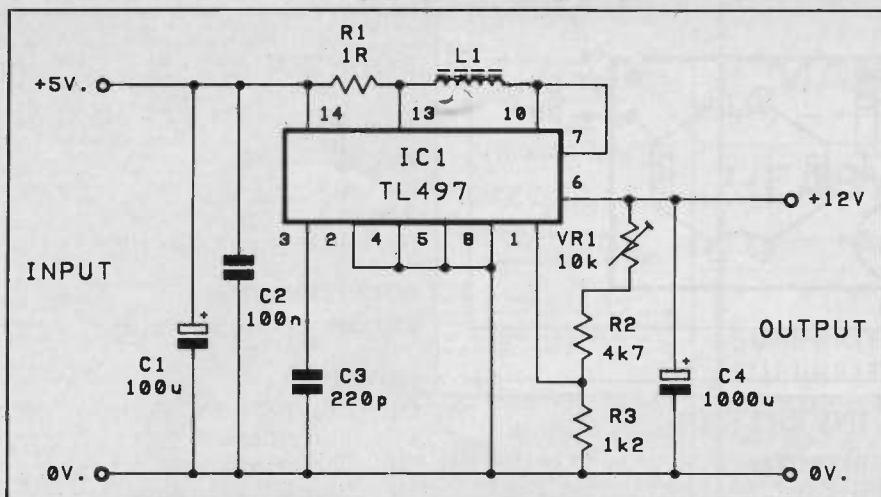

Fig.5. Circuit diagram of the booster regulator.

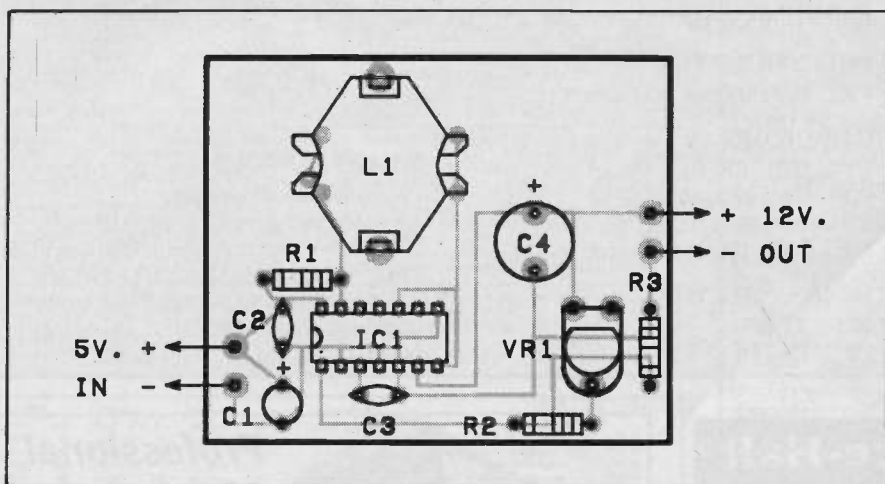

Fig.6. PCB layout for the booster regulator

INVERTER CIRCUIT

The circuit diagram for the inverter regulator appears in Fig.7, and this is again much the same as the step-down regulator but with the output stage rearranged into the standard inverter configuration. There are a few other minor changes, one of which is the connection of IC1's substrate terminal (pin 4) to the output of the circuit. The negative feedback network also has to be altered in order to take account of the fact that the output is negative of the earth rail. With the substrate connected to the output, the voltage reference provides a voltage that is nominally 1.2 volts positive of the negative output rail, and in effect this rail becomes the earth rail to which all voltages are referenced as far as the stabilisation process is concerned. Therefore, the 1k2 resistor (R3) connects between the inverting input and the 0 volt rail (which is effectively the positive output rail as far as the regulator circuits are concerned). This gives what is essentially the same negative feedback and stabilisation process as in the previous circuits, with the nominal output voltage again being equal to the total feedback resistance in kilohms.

Construction of the unit is much the same as for the other two circuits, and details of the printed circuit board are provided in Fig.8. Note that in this circuit L1 only requires 18½ turns.

Despite a fair amount of experimentation with this circuit I never managed to coax particularly high output currents from it, and an output of about 150 milli-

amps represent about the maximum that can be expected. On the other hand, this compares well with circuits based on the popular ICL7660 which give an output of under 5 volts even with quite modest loading on the output, and would not normally be used for output currents of more than about 10 milliamps. This circuit will give about 150 milliamps without any significant loading of the output below its nominal -5 volt level. Efficiency of the circuit was also disappointing at only about 50%, although this is quite reasonable by general power supply standards and is certainly perfectly usable. As with the previous circuits, there is some latitude as to the exact input and output voltages, and the unit will, for example, generate a -5 volt output from a +12 volt input (provided C1 is changed to a 16V type). In fact it seems to operate more efficiently when operated in this way, offering an efficiency of around 75% and a maximum output current of approximately 400 milliamps.

CONCLUSION

These circuits all represent useful electronic building blocks which are well worth considering for inclusion in a project that has unusual or awkward power supply requirements. They also represent interesting projects to experiment with if you are new to switch mode power supplies, and they give an easy and inexpensive introduction to the subject. PE

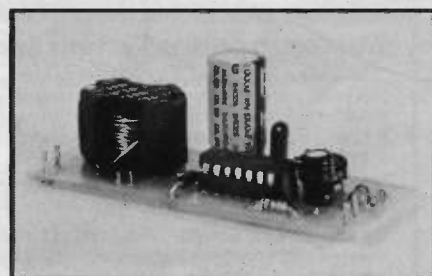

Inverter regulator

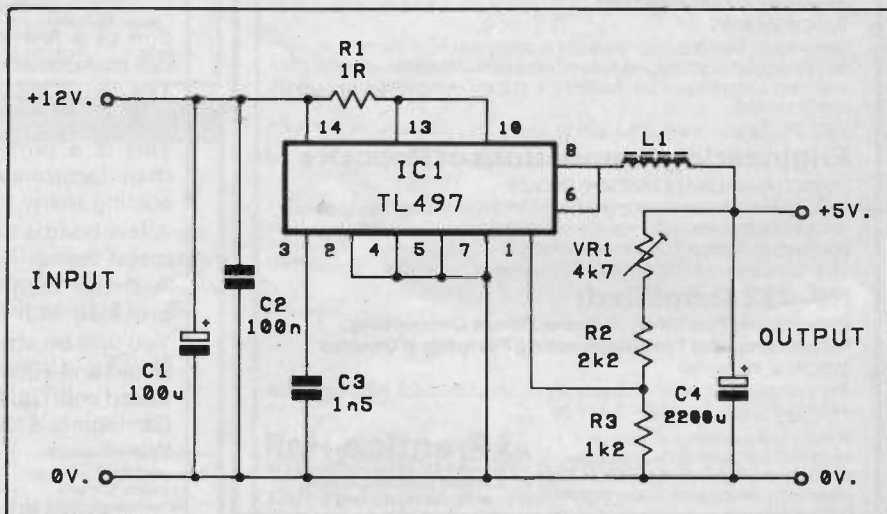

Fig.7. The inverter regulator circuit diagram.

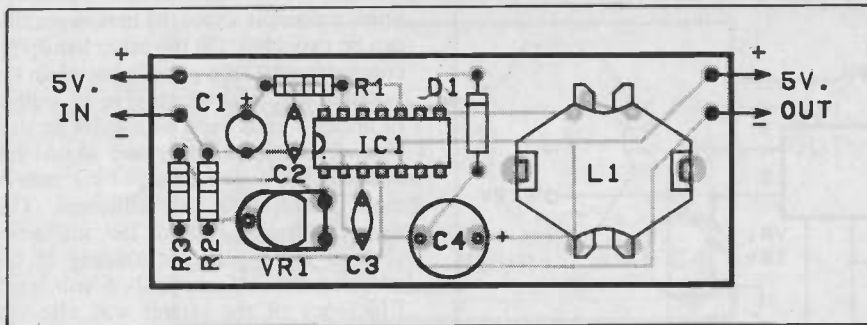

Fig. 8. The inverter PCB layout

BOOSTER

RESISTORS

R1 1_R
 R2 4k7
 R3 1k2
 All resistors 1/3 watt 5% carbon

POTENTIOMETER

VR1 10k sub-min hor. preset

CAPACITOR

C1 100μ 10V radial elect
 C2 100n ceramic
 C3 220p ceramic plate
 C4 100μ 16V radial elect

SEMICONDUCTOR

IC1 TL497

MISCELLANEOUS

(Common to all circuits)
 L1, LM8 pot core type B65811
 J0000R041, former type B65812 A1005
 D001, clamp B65812 A2203 (2 off),
 22 s.w.g. enamelled copper wire, printed
 circuit board, 14 pin DIL i.c. socket,
 pins, solder, etc.

STEP-DOWN REGULATOR

RESISTORS

R1 1_R
 R2 2k2
 R3 1k2
 All resistors 1/3 watt 5% carbon

POTENTIOMETER

VR1 4k7 sub-min hor. preset

CAPACITORS

C1 100μ 16V radial elect
 C2 100n ceramic
 C3 1n5 mylar
 C4 2200μ 10V radial elect

SEMICONDUCTOR

IC1 TL497

INVERTER

RESISTORS

R1 1_R
 R2 2k2
 R3 1k2
 All resistors 1/3 watt 5% carbon

POTENTIOMETER

VR1 4k7 sub-min hor. preset

CAPACITORS

C1 100μ 10V radial elect
 C2 100n ceramic
 C3 In mylar
 C4 100μ 10V radial elect

SEMICONDUCTORS

IC1 TL497
 D1 1N4001

Books from Prentice-Hall

Microprocessor System Servicing

J. D. FERGUSON, L. MACARI AND P. WILLIAMS

Assuming a general knowledge of electronics, including digital techniques, this book presents the engineer or technician with a range of techniques for the location and solution of microprocessor (8- and 16-bit) faults.

1987 288 pages 13-581132-5 £14.95 paper

The Single Chip Microcomputer

S. J. CAHILL

Based on the 6802 and 6805 family of chips, this book provides an accessible overview of the principles and operation of single chip microcomputers

1987 400 pages 13-810581-2 £14.95 paper

Optical Sensing Techniques and Signal Processing

TUDOR JENKINS

Designed for final year undergraduate or postgraduate students in departments of electronics and physics, this book will also be of use and interest to professionals required to set up experimental systems using optical sensors.

1987 256 pages 13-638107-3 £29.95 cloth

Engineering Foundations of Robotics

FRANCIS N-NAGY AND ANDRAS SIEGLER

Dealing with the design and control fundamentals of robot manipulators, this is a practical introduction to the engineering and mathematical principles of robot motion and positioning.

1986 320 pages 13-278797-0 £14.95 paper

RS-232 Simplified:

Everything You Need to Know About Connecting, Interfacing and Troubleshooting Peripheral Devices

BYRON W. PUTMAN

The sub-title says most of what you can say about this book in a short space!

1987 264 pages 13-783499-3 £17.35 paper

Prentice-Hall publishes a wide range of electronics and computer science books for engineers and students. For more information, please write to Jean Walmsley.

Prentice-Hall
 SIMON & SCHUSTER INTERNATIONAL GROUP
 66 Wood Lane End, Hemel Hempstead,
 Hertfordshire, HP2 4RG, England.

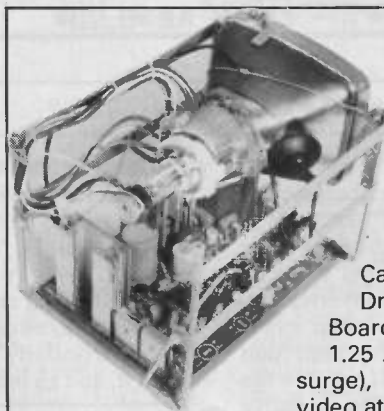

Professional Monitor Drive Board & Tube

This Crofton Monitor Kit comprises a 12" P31 Cathode Ray Tube and Drive Board. The Drive Board requires 12 volts at 1.25 Amp continuous (1.85A surge), separate line, field and video at TTL levels. By the addition of a few standard components this board can be driven from standard composite signals.

The Drive Board has a bandwidth of 24 MHz and is capable of displaying 25 lines of 80+ characters.

This is a professional board and tube as supplied to manufacturers of terminals, and out performs monitors costing many times this price.

A few boards and tubes are also available mounted on a metal frame.

A circuit diagram, together with full instructions, are provided with each board and tube. You will be absolutely delighted with the performance.

Board and Tube **£34.50 inclusive of VAT**
 Board and Tube on Metal Frame **£40.25 inclusive of VAT**
 Carriage is £13.50 or come and collect direct from our Warehouse.

Crofton Electronics,
"Kingshill", Nextend, Lyonshall, HR5 3SX.
Telephone: 05448 557

DIGITAL ELECTRONICS

MADE EASY



SUPERKIT £22.00
SUPERKIT II £16.00
(£35.00 if bought together)

The SUPERKIT series introduces beginners to practical digital electronics. SUPERKIT (SUP I) is the first kit, which contains an instruction manual, a solderless breadboard, and components (7 integrated circuits, switch, resistors, capacitors, LEDs and wire). It teaches boolean logic, gating, flipflops, shift registers, ripple counters and half adders. SUPERKIT II (SUP II) extends SUPERKIT. It contains an instruction manual and components (10 integrated circuits, 7-segment display, resistors, capacitors and wire), and explains how to design and use adders, subtractors, counters, registers, pattern recognisers and 7-segment displays.

DIGITAL COMPUTER LOGIC £7.00
DIGITAL COMPUTER DESIGN £9.50
MICROPROCESSORS & MICROELECTRONICS £6.50

The SUPERKIT series is backed by our theory courses. DIGITAL COMPUTER LOGIC (DCL), the beginners' course, covers the use and design of logical circuits, flipflops and registers. DIGITAL COMPUTER DESIGN (DCD), a more advanced course, covers the design of digital computers both from their individual logic elements and from integrated circuits. MICROPROCESSORS and MICROELECTRONICS (MIC) teaches what a microprocessor is, how it evolved, how it is made and what it can do.

GUARANTEE: If you are not completely satisfied, return the item to us in good condition within 28 days for a full refund. All prices include worldwide surface postage (ask for prepayment invoice for airmail). Orders despatched within 48 hours. Overseas payment by international credit card or by bank draft drawn on a London bank.

CAMBRIDGE LEARNING LTD, Unit 29, Rivermill Site, FREEPOST, St. Ives, Huntingdon, Cambs. PE17 4BR, England. Telephone: 0480 67446.

VAT No. 313026022 Transcash No. 2789159 Reg. No. 1328762

Please send me (initial letters used):

..... SUP I @ £22.00 DCL @ £7.00
 SUP II @ £16.00 DCD @ £9.50
 SUP I + II @ £35.00 MIC @ £6.50

Full details of all your courses (please tick)

I enclose a cheque/PO payable to Cambridge Learning Ltd. for £.....

Please charge my credit card.

No. Expiry date

Telephone orders from credit card holders accepted on 0480 67446 (24 hrs).

Name

Address

Signature

CAMBRIDGE LEARNING LTD
 Unit 22, Rivermill Site, FREEPOST,
 St. Ives, Huntingdon, Cambs PE17 4BR
 England.



VARIABLE VOLTAGE TRANSFORMERS

INPUT 220/240V AC 50/60 OUTPUT 0-260V	
200Watt 0.1 amp max.	£19.50 £3.00 (£25.88 inc VAT)
0.5KVA 2.5 amp max.	£22.00 £3.75 (£29.60 inc VAT)
1KVA 5 amp max.	£31.00 p&p £4.25 (£40.24 inc VAT)
2KVA 10 amp max.	£45.00 £5.50 (£58.08 inc VAT)
3KVA 15 amp max.	£59.00 £6.25 (£75.05 inc VAT)
5KVA 25 amp max.	£105.00
10KVA 50 amp max.	£190.00
15KVA 75 amp max.	£285.00

3-PHASE VV TRANSFORMERS

Dual input 200-240V or 380-415V. Star Connected 3KVA 6KVA 10KVA available. Phone for details. Comprehensive range of TRANSFORMERS - L.T. - ISOLATION & AUTO (110-240V). Auto transf. either cased with American socket and mains lead or open frame type. Available for immediate delivery. Leaflet on request.

ULTRA VIOLET BLACK LIGHT FLUORESCENT TUBES

4ft. 40 watt £10.44 (£12.00 inc VAT) Callers only
2ft 20 watt £7.44 + £1.25 p&p (£9.99 inc VAT)
15in 10 watt £5.50 + 75p p&p (£7.19 inc VAT)
12in 8 watt £4.50 + 75p p&p (£6.04 inc VAT)
9in 6 watt £3.60 + 50p p&p (£4.72 inc VAT)
6in 4 watt £3.60 + 50p p&p (£4.72 inc VAT)

230V AC BALLAST KIT for either 6W

9in or 12in tubes: £5.50 p&p 55p (£6.96 inc VAT)

For 1.3m tubes: £6.00 p&p 75p (£7.76 inc VAT)

400 WATT UV LAMP & BALLAST Complete

£56.80 + £3.50 p&p (£69.35 inc VAT)

400 WATT UV LAMP

only £28.00 p&p £2.50 (£35.08 inc VAT)

175 WATT SELF BALLASTED BLACK LIGHT

MERCURY BULBS Available with BC or ES fitting £14.00 p&p £1.25 (£17.54 inc VAT)

12V DC BILGE PUMPS

Buy direct from the importers

500 GPH 15 ft. head 3 amp

£10.50 p&p £1.50 (£13.80 inc VAT)

700 GPH 10ft. head 3.5 amp

£13.50 p&p £1.50 (£17.25 inc VAT)

1750 GPH 15ft. head 9 amp

£16.75 p&p £2.00 (£21.56 inc VAT)

EPROM ERASURE KIT

Build your own EPROM ERASURE for a fraction of the price of a made-up unit. Kit of parts less case includes 12in. 8 watt 2537 Angst. Tube. Ballast unit, pair of bin-pins leads, neon indicators, on/off switch, safety microswitch and circuit. £13.60 p&p 75p (£16.65 inc VAT)

SANGAMO WESTON TIME SWITCH Type S251

200/250V AC 2 on/2 off every 24 hours. 20 amp. controls with override switch. Suitable for immersion heaters. 4" Dia x 3" high. £9.50 £1.50 p&p (£12.65 inc VAT) R&T. Also available with Solar Dial. Other Time Switches available from stock.

SUPER HY-LIGHT STROBE KIT

Designed for Disco. Theatrical users etc. Approx 16 joules, Adjustable speed £45.00 p&p £2.00 (£54.05 inc VAT) Case and reflector £17.00 p&p £2.00 (£21.95 inc VAT) S.A.E. for further details including Hy-Light and Industrial Strobe Kits.

ROBOT ENTHUSIASTS

ESCAP precision Swiss-made ironless rotor 6V DC. Geared motor with 70-1 gear. 5V DC - 16 RPM. 3V DC - 8 RPM. Amazing power; no load current; only 10 ma. approx. Size 40x25 mm. Ex-Equip. tested and guaranteed. ONLY £4.50 p&p 50p. (£5.75 inc VAT).

38.3 RPM GEARED MOTOR Torque 35lb. in. reversible 115V AC inc. start capacitor £14.00 p&p £2.00 (£18.40 inc VAT). Suitable TRANSFORMER For 230V AC operation. £5.20 p&p £1.00 (£7.13 inc VAT).

24V DC SOLENOID VALVE m.f. by Sperry Vickers. Orf. 3/32" Brass body, designed for Air Gas and Water. £8.50 p&p £1.00 (£8.63 inc VAT) N.M.S.

240V AC SOLENOID VALVE. Designed for Air/Gas/O.7 Water 5 psi. inlet-outlet 3/8" BSP Forged brass body. Mf. Dewraswitch Asco. £6.50 p&p £1.00 (£8.63 inc VAT) N.M.S.

SOLID STATE RELAY

Single make relay with switch up to 250V AC 10 amps. Recommended operating voltage 8-28V DC. but will work at less than 5V DC. Silent contactless, opto isolated. Suitable for use with T.L.L. Logic for switching Mains voltage. Mf. by Teledyne. Offered at a fraction of its price. £3.00 p&p 45p (£3.97 inc VAT).

COOLING FANS - BRAND NEW!

200/240V A.C. American Boxer "Pewee" 7-bladed, high efficiency cooling Unit. 80 mm sq. x 40 mm deep. 40 cfm. approx.

American Boxer "mini" 5-bladed, 92 mm sq. x 38 mm deep. 50 cfm approx. Either type at fraction of manuf.'s price. £8.00 + £1.00 p &p. (£10.35 incl. VAT).

S.M.F.I. - CROUZET "Mini" 115V A.C. 5-bladed, 92 mm sq. x 25 mm deep. 40 cfm approx. Price: £6.00 + £1.00 p &p. (£8.05 incl. VAT).

EX-EQUIPMENT FANS, 120 mm sq. x 38 mm deep. In either 115V or 230V A.C. Tested and guaranteed. Price: £5.75 + £1.00 p &p. (£7.77 incl. V.A.T.)

VBM4 CENTRIFUGAL BLOWER 230V AC.

2,800 RPM. 0.23 amp. Cast const. incl. mounting feet. 100mm dia impeller. Outlet: 40x43 mm. Overall size: 160x150x165 mm long. £18.00 p&p £2.75 (£23.86 inc VAT).

TORIN CENTRIFUGAL BLOWER 230V AC.

Pressed steel const. 2,800 RPM. 0.9 amps 130 mm dia. impeller. Outlet 63x37 mm. Overall size: 195x160x150 mm long. (15.00 p&p £2.75 (£20.41 inc VAT).

FROM STOCK AT PRICES THAT DEFY COMPETITION

AC Geared Motors C/F Blowers
 DC Motors Small A.C. Capacitors
 Microswitches Relays
 Solenoids AC & DC Switch Motors
 Programme Timers

WIDE RANGE OF XENON FLASH TUBES

Write/Phone your enquiries

Carriage on request.

Goods normally despatched within 7 days N.M.S. & R+T



Ample Parking Space
 Showroom open Monday-Friday



SERVICE TRADING CO

57 BRIDGMAN ROAD, CHISWICK, LONDON W4 5BB

01-995 1560

ACCOUNT CUSTOMERS MIN. ORDER £10

Personal callers only.
 Open Saturdays
 9 Little Newport Street
 London WC2H 7JJ
 Tel: 01-437 0576

CMOS	LINEAR	TRANS.	SWITCHES	MULTIMETERS
4001 16 741C 20	CA3149E 42	BC107 14	Push to Make 17	1KV 8 Ranges £6.45
4011 16	CA3149E 42	BC108 14	Push to Break 24	4KV 11 Ranges £7.70
4013 24	LF351 46	BC109 14	Min Toggle SPST 58	10KV 15 Ranges £9.40
4017 35	LM38090	BC109C 16	Min Toggle SPDT 85	20KV 22 Ranges £13.40
4021 38	LM339 37	BC337 10	Min Toggle DPDT 73	LCD Digital 15 Ranges £21.90
4023 16	LM339 39	BC547 11	Rotary 1P 12 Way 58	All Meters are supplied complete with battery, test leads and instructions.
4027 22	LM566 128	BC557 11	Rotary 2P 6 Way 58	
4028 34	LM1458 40	BD131 45	Rotary 3P 4 Way 58	
4031 123	LM13600 120	BD132 47	Rotary 4P 3 Way 58	
4040 38	MC1496 108	BD139 34	Keyswitch SPDT 210	
4048 49	NE555 22	BD140 34	2 Keys Supplied 210	
4040 22	NE556 52	BD222 85	3 Pin Din Plug 13	RECHARGEABLE BATTERIES
4051 46	NE565 110	BF224 38	5 Pin Din Plug 15	AA (HP7) Nicad £1.20 ea
4060 45	NE5534 120	BF241 31	3 Pin Din Socket 15	C (HP11) Nicad £2.15 ea
4086 24	SO42P 230	BF256 43	5 Pin Din Socket 16	D (HP2) Nicad £3.10 ea
4088 16	SL1621 810	BF961 77	3.5mm Jack Plug 14	PP3 Nicad £4.35 ea
4089 16	SL1640C 510	BF961 94	3.5mm Jack Sckt. 11	
4071 16	TL071 48	BFY50 26		UNIVERSAL NICAD CHARGER
4073 16	TL072 65	BFY51 26		Will charge all the above types. £8.25
4075 16	TL084 100	BFY90 88	SOLDERING IRON 24w	
4078 48	TL497 485	IRF9530 645	Long Life Element 240V £3.95	
4078 28	XR2206 480	MJE3055 84		
4081 16	XR2211 346	VN10M 90		
4093 22	7805 42	VN10LM 76		
4099 69	7812 42	ZTX10715 15		
4503 48	7815 42	ZTX108 15		
4516 44	7824 42	ZTX109 15		
4541 42		2N3053 29		
4555 35		2N3055 59		
		2N3072 14		
		2N3704 14		
		2N3819 40		
		2N3866 142		
		2N3904 14		



C.P.L. ELECTRONICS

PLEASE ADD 70p P&P AND THEN 15% VAT TO TOTAL.

Quantity discounts available. All components are new and to full spec. FREE PRICELIST ON REQUEST.

CHEQUE OR P.O. TO C.P.L. ELECTRONICS

8 Southdean Close, Hamlington, Middlesbrough, TS8 9HE

Tel: 0642 591157

ACCESS/VISA ORDERS BY TELEPHONE OR POST WELCOME

Sorry! Limited to one only per customer

FREE

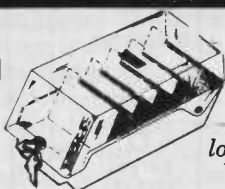

large (100 disk capacity) lockable disk storage box worth £13.95 -

- When you buy 25 disks for only £22.95 including postage and VAT!

Disks are high quality 5 1/4" Double Sided/Double density. Add 15% if you want quadruple density.

Nebulae, Dept PE, FREEPOST, Kilroot Park Industrial Estates, Carrickfergus, Co Antrim, BT38 7BR TEL (09603) 65020

7 Day Delivery, One year guarantee, & 14 day money back period.

We accept orders from all government bodies, schools, universities, PLC's etc. We despatch on receipt of an official purchase order.

SENSORS

PART ONE BY THE PROF

Translating the environment into control signals

Sensors are an essential stage in translating non-electrical signals into a form which electronics can detect and control. Part one of a two-part article looks at the Hall effect, gas and light sensors, and strain gauges.

ONE of the biggest growth areas of electronics in recent years has been measurement and control, and with it a whole range of electronic sensors has become available. It now seems to be possible to measure electronically practically anything that can be quantized, and to detect virtually any substance or form of energy. Sensors vary in complexity from simple mechanical devices such as micro-switches to complex semiconductor devices. In an article such as this it is only possible to scratch the surface of this subject, and we will mainly be concerned with the types of sensor which are available to the amateur user who wishes to experiment with them, but which are rarely (if ever) featured in constructional articles. It is not possible to give practical circuits using the devices covered, and only the fundamentals of their operation and the basic way in which they are used will be covered, but some of the sensors may be featured in practical projects in future issues.

HALL EFFECT

Sensors which take advantage of the Hall effect might have few obvious practical applications, but they are certainly amongst the most interesting of components, and while not dirt cheap, are far from the most expensive of devices. They are designed to detect magnetic fields, and apart from the obvious application of magnetic field strength measurement, Hall effect devices are often used as "noiseless" switches in conjunction with an actuating magnet. In fact most Hall effect devices seem to be of the switching type rather than linear sensors.

The general idea of a Hall effect switch is to have a keyboard fitted with keys that contain magnets, with a sensor mounted under each switch. When a key is operated the magnet within it is brought close to the corresponding Hall effect sensor which is consequently activated, and its output changes state. There is no contact bounce with this arrangement, although spurious signals could still be produced if a key was not operated properly and was not fully depressed. The sensor therefore incorporates a certain amount of

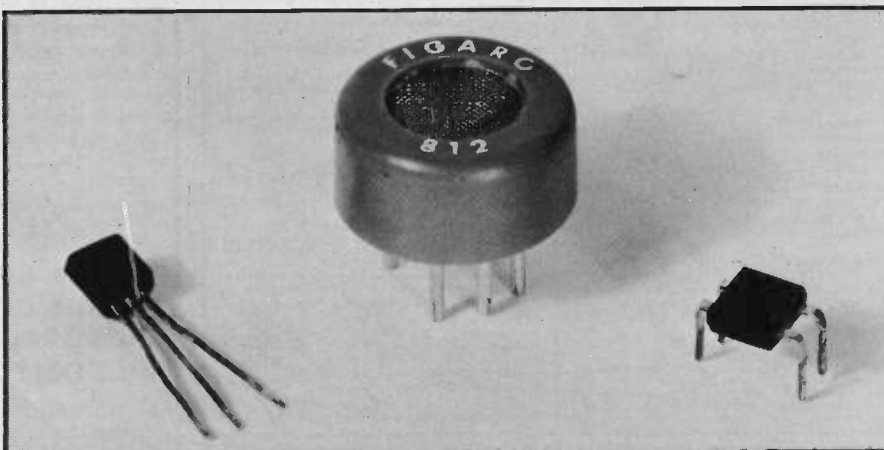

Hall effect switch, Figaro 812 gas sensor and Linear Hall Effect Sensor.

hysteresis so that it is almost impossible to produce spurious output pulses.

This approach may seem rather like "taking a sledgehammer to crack a nut", and it is a comparatively expensive way of doing things. Apart from the "noiseless" aspect, the lack of any switch contacts gives a long operating life and excellent reliability which can justify the extra expense in the more demanding of applications. Hall effect switches are not only suitable for keyboard purposes, and they are apt to a whole range of switching applications. In particular they are excellent for use in situations where reed switches would normally be utilised, which includes such things as door and window switches in burglar alarm systems, and train detectors in model railway layouts.

So just what is the Hall effect, and how does a Hall sensor operate? Fig.1 helps to explain the way in which these devices function, and in Fig.1(a) we have a thin slice of silicon with two electrodes fitted on opposite sides, but otherwise at the same point on the slice. A current is passed through the silicon slice, and this gives a potential gradient which ranges from 0 volts at the bottom of the slice to the full input voltage at the top. The electrodes are about half way up the slice, and about half the input voltage appears at each one. The exact voltage is not important, and the salient point here is that the same voltage will be present at each electrode, giving a differential output voltage of zero.

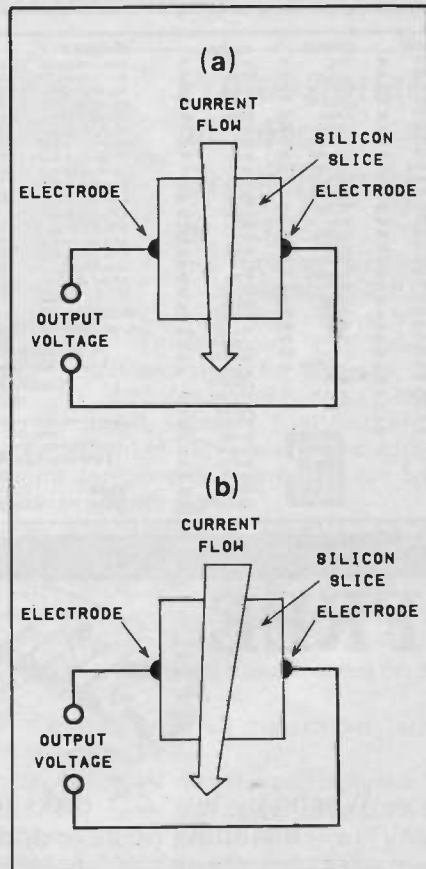

Fig.1. (a) Normal current flow through semi-conductor material, and (b) the effect of a suitable magnetic field on the current flow.

In Fig.1(b) a magnetic field has been introduced, and this is perpendicular to the direction of the current flow. The result is a deflection of the current carriers, rather like a magnetic field deflecting the electron beam of a cathode ray tube. This results in a distortion of the potential gradient, and with this distortion in the direction shown in Fig.1(b), this results in the voltage at one electrode increasing and the voltage at the other electrode decreasing. This gives a voltage difference across the electrodes, and the stronger the magnetic field, the larger the differential output voltage. If the polarity of the magnetic field is reversed, so is the polarity of the output signal, and this the factor which is exploited in some practical devices.

An important point to bear in mind when using Hall effect devices, is that they will only respond properly to a magnetic field in the correct direction, and that a field at right angles to this direction gives no output signal whatever.

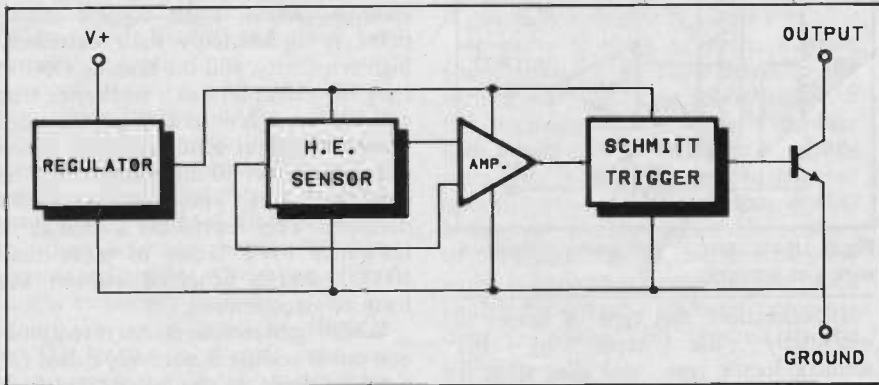

Fig.2. Typical arrangement for a Hall effect switching device.

Practical Hall effect devices are generally more than just the sensor itself, and a typical device would have an internal arrangement of the type shown in Fig.2 (which is actually the arrangement used in the RS 307-446 device). There is an internal voltage regulator to ensure consistent results from the component, and this provides power to all stages. The output from the Hall effect sensor is fed to a differential amplifier, and when the device is activated this provides sufficient output to operate a Schmitt trigger. The latter then switches on an npn transistor which has an open collector output which can be used to drive a logic input, or to operate directly a small load such as a l.e.d. indicator or a small relay.

This arrangement is by no means universal, and there are alternative types, including one which latches in the "on" state, and which can only be switched off by briefly cutting off the power to the device, or applying a reverse magnetic field. Another type, and one which is interesting to experiment with, is the linear type. This is basically just a Hall effect sensor with

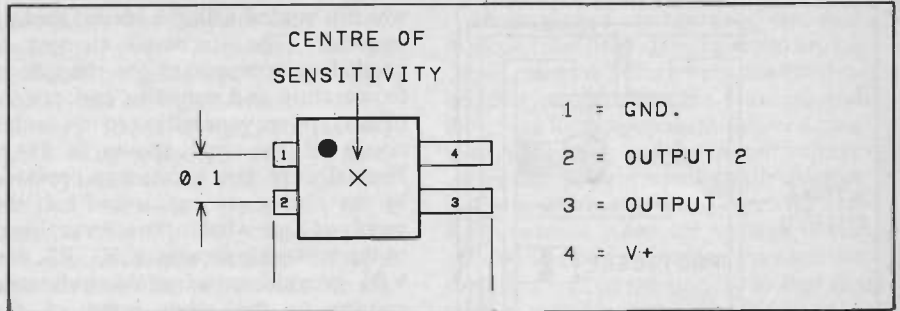

Fig.3. Pinout details for the 634SS2 linear Hall effect device.

the two outputs available via buffer amplifiers. The 634SS2 is an example of a device of this type, and Fig.3 gives pinout and basic physical details of this component. It operates in the circuit shown in Fig.4, and it only needs two load resistors and a supply voltage of between 4 and 10 volts. Note that although differential outputs are available, it is not essential to use both of them, and in non-critical applications it would be quite acceptable to use a single output.

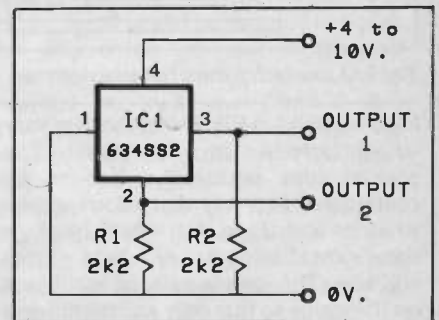

Fig.4. Basic circuit for the 634SS2

conventional types. At a simpler level I once tried a linear Hall effect device in a cable locator of the type designed to pick up the magnetic "hum" radiated by mains cable which is passing an electric current. This was completely unsuccessful due to a gross lack of sensitivity, and the output from a Hall effect sensor would seem to be far lower than that from an inductive sensor. However, whereas a simple inductive sensor will detect only a varying field, a Hall type will detect a field of constant strength, which can be crucial in some applications.

IN VANE

There is a type of Hall effect switch that is intended for counting applications of the type where a slotted opto sensor would normally be used, but is unsuitable due to excessive ambient light or high dust levels. These devices are called Hall effect vane switches, and they are really just a bar magnet and an ordinary Hall effect switch combined in a single printed circuit mounting component. The magnet is just too far away from the Hall effect switch to activate it, but if a piece of ferrous metal (the "vane") is placed in the gap, it effectively extends the magnet and activates the switch. Of course, a sensor of this type is only suitable for operation with ferrous metals, unlike slotted optical sensors. They are capable of quite high speed operation, with a maximum of about 100kHz being typical.

GAS SENSORS

There are several ways of detecting gas or smoke, and the simplest types are photoelectric devices intended only for smoke detection. These take the general

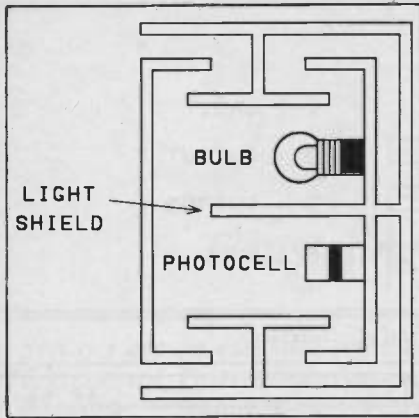

Fig. 5. A low tech form of smoke detector

form outlined in Fig. 5, and they are very straightforward in operation. The general idea is for the box to be constructed in a way that allows smoke to enter and leave, but which blocks a significant amount of light from entering. The case is painted mat black on the inside so that only an insignificant amount of light normally reaches the photocell from the light source. An ordinary filament bulb is preferable to a light emitting diode in this case, as it will generate more heat and will consequently encourage a flow of air through the box. This helps to draw in any smoke in the air surrounding the unit. If any smoke should be drawn into the case, it will tend to reflect light from the lamp onto the photocell, and with suitable circuitry, this increased light level can be detected and used to trigger an alarm.

This is not the only possible type of photoelectric smoke detector, and there are similar systems which have the light source aimed at the photocell, and rely on the smoke to vary the light intensity received by the photocell. These days there are more sophisticated types of smoke sensor available, including types which will detect practically any inflammable gas or vapour, even when they are only present in highly diluted form. The "Figaro" 812 and 813 gas detectors have been featured in constructional projects in the past, and these have a semiconductor sensing element. The element is heated by an ordinary filament type heater, and it oxidizes the semiconductor element which consequently exhibits a fairly high resistance (typically around 100k or more). Suitable gasses have a reducing (deoxidizing) effect on the element, which results in its resistance falling quite dramatically, and even quite weak concentrations of gas are sufficient to cause the resistance to drop to just a few kilohms.

There is an alternative type which is less widely used in home constructor designs (but which is available to amateur users in the form of the RS 307-733 sensor). This has two platinum wire elements which are heated, and one of

which is coated with the special sensing materials. The uncoated element is needed to compensate for changes in temperature and humidity, and devices of this type are generally used in a bridge circuit of the type shown in Fig. 6. Normally the two resistances provided by the sensor are equal, and half the supply voltage is fed to the relevant input of the voltage comparator. R1, R2, and VR1 provide an adjustable reference voltage to the other input of the comparator. VR1 is adjusted to provide a voltage that is just above or below half the supply voltage, so that under stand-by conditions the output of the comparator is sent high or low, as required. Any drift in the resistance of one section of the element should be matched by a similar change in the resistance of the other section, so that the output from the sensor remains unchanged.

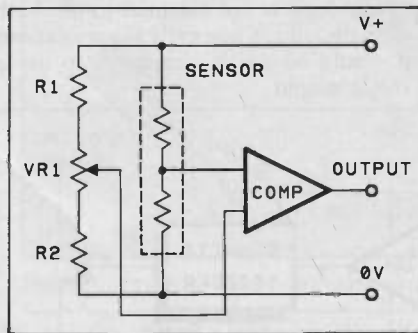

Fig. 6. Basic circuit for using platinum wire gas sensors.

In operation, this type of sensor is essentially the same as the semiconductor type, and uses what is apparently called the "pellistor" principle. There is a fundamental difference between the two types in that the semiconductor type has separate heating elements, whereas with the platinum wire type the two wires act as both the heating and sensing elements. Both types are capable of detecting gasses such as butane and methane, and at concentrations that are well below the explosive threshold. Of course, this still leaves a danger of the heating elements igniting the detected gasses if they should be allowed to continue to build up after detection, and to avoid this the elements are shielded by double wire netting. The platinum wire devices have good linearity and are suitable for measurement applications as well as operation in simple detection circuits. However, both types of sensor are more sensitive to some gasses than they are to others, and the scaling would need to be for a specific gas.

LIGHT SENSORS

There is no shortage of devices for the detection of light, and most readers will probably be familiar with cadmium sulphide photo-resistors, such as the ORP12, and various semiconductor light

sensitive devices. For simple switching applications and the like, the choice of device is generally not too critical, except where high operating speed is required. Photo-diodes are then the normal choice, although the price that has to be paid for the relatively fast response time is a rather low level of sensitivity. Cadmium sulphide photo-resistors and photo-darlington devices offer very high levels of sensitivity, but are extremely slow, particularly some of the larger cadmium sulphide devices which can take several seconds to adjust to changes from very bright to very dark conditions.

Cadmium sulphide cells usually have a zigzag track of this material (which is clearly visible through its transparent protective covering), which is deposited on an insulating substrate, and they rely on the fact that the resistance of cadmium sulphide decreases as the light level is increased. Although regarded by many as completely out of date, there are many non-critical applications where this type of cell represents the most suitable choice. Their biggest selling point is undoubtedly their extremely high sensitivity, and the humble ORP12 type for example, has a resistance that can be just a few tens of ohms under extremely bright conditions, but which can rise to over 10 megohms when the component is subjected to total darkness. This represents a change in resistance by a factor of more than 100000, and is achieved without any form of amplification.

Where light measurement is required, and linear scaling is normally called for, a photo-diode is the usual choice of sensor. There is not really a great deal of difference between an ordinary semiconductor device and its photo-sensitive equivalent. Semiconductor devices are naturally light sensitive, but are normally housed in opaque encapsulations, to avoid changes in light level affecting their performance. With the photo-sensitive devices the semiconductor material is mounted beneath a window (or often a simple lens in fact), so that light can reach it. Those who can remember electronics construction in the 1960s may recall the old ploy of scraping off the paint from an OC71 transistor (with its glass casing) to effectively turn it into an OCP71 photo-transistor, but at a fraction of the cost of a genuine OCP71. A trick that worked well until an opaque filling was introduced between the semiconductor and the glass casing.

Photo-diodes can be used as photo-voltaic cells (i.e. to generate a voltage in the presence of light), but they are more usually operated in the reverse biased mode. This gives a slightly higher level of sensitivity, although compared with most other photocells, photo-diodes are very insensitive in either mode. Under darkness the diode has the

normal low reverse leakage level associated with a silicon diode, but under bright conditions a somewhat higher leakage current flows. When operated in the reverse biased mode, there is a linear relationship between light level and output current over a wide range of light levels.

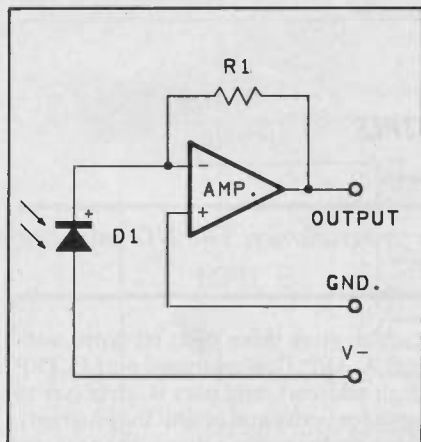

Fig. 7. Using a photo-diode in a measuring circuit which has a linear response.

When photo-diodes are used in measuring applications they are normally operated in the basic configuration shown in Fig. 7. This is similar to the standard operational amplifier inverting mode, with the obvious exception that there is no input resistor and the photo-diode feeds direct into the inverting input of the operational amplifier. Operation of the circuit is essentially the same as for an ordinary inverting amplifier though, with D1 leaking a current into the negative supply rail. In order to maintain equilibrium at the two inputs of the operational amplifier, the output must swing positive. The output goes positive by an amount which drives a current through R1 that exactly matches the current flow through D1. The circuit thus gives a simple current to voltage conversion, and the higher the value of R1, the greater the output voltage that a given input current will produce.

Apart from straightforward light measuring applications, a circuit of this type can form the basis of more exotic circuits such as flash-meters. These usually have an integrator which is used in such a way that the final reading takes into account both the intensity of the light pulse and its duration (both of which affect the exposure value). The high speed of photo-diodes is important in this application, and most types can respond to large changes in light level in under a microsecond.

TAKING THE STRAIN

Strain gauges seem to feature little (if at all) in home constructor projects, but are one of the most common types of sensor. They are used in the testing of mechanical structures, including such things as aeroplane wings, bridges, and

buildings. In fact they are used to test practically every structure where physical strength and long term reliability are of importance.

Modern strain gauges are usually formed using a photo-etching process, and they consist of a grid of fine wire which is normally contained in a protective coating of polyester. The latter also serves as a medium to couple the strain from the test material to the gauge itself. The wire is often made from a copper-nickel alloy which has a very low temperature coefficient, so that changes in temperature have a very small (and predictable) effect on the resistance through the component.

The sensor gives a change in resistance when it is flexed, due primarily to stretching, or compression of the wire. Apart from altering the length of the wire, this also changes its cross section, and both factors produce a change in resistance. There is another factor which contributes to the variation in resistance, and this is the change in the structure of the material, but this second influence is generally a relatively minor one.

In order to work properly, a strain gauge must be properly fixed to the surface which is being monitored, and this normally means gluing it in place with a high quality adhesive. An epoxy resin type is suitable, and the layer of adhesive must be kept very thin, so that it does not absorb a significant amount of the strain. The surface to which the gauge is fixed must be carefully prepared so that the adhesive sticks to it properly over the entire area covered by the gauge.

Strain gauges are normally operated in some form of bridge or pseudo bridge circuit, and the basic type is the quarter-bridge type shown in Fig. 8(a). R1 and the gauge form a potential divider across the supply lines, and the output voltage varies slightly in sympathy with changes in the resistance of the gauge. R2 and R3 provide a reference voltage which offsets the quiescent output voltage from the other half of the bridge, so that the output voltage from the circuit as a whole is equal to the change in voltage when the gauge is stressed. Normally the output signal would be coupled to a high gain differential amplifier in order to boost the signal to a useful level. As the amplifier has to be d.c. coupled, and only small input voltage changes are involved, the resistors must be high quality types. Also, the operational amplifier used as the basis of the differential amplifier, must be a special low drift type – the humble 741C is not suitable for a demanding application of this type.

In some applications, particularly those in which compression is being sensed, strain gauges are used in all four arms of the bridge. This gives the so called full bridge circuit of Fig. 8(b).

For those who like to experiment with such things, a useful range of strain gauges are available through RS stockists. PE

NEXT MONTH:
PART TWO WILL DISCUSS
THERMISTORS, THERMOCOUPLES,
PYRO DETECTORS,
AND pH PROBES.

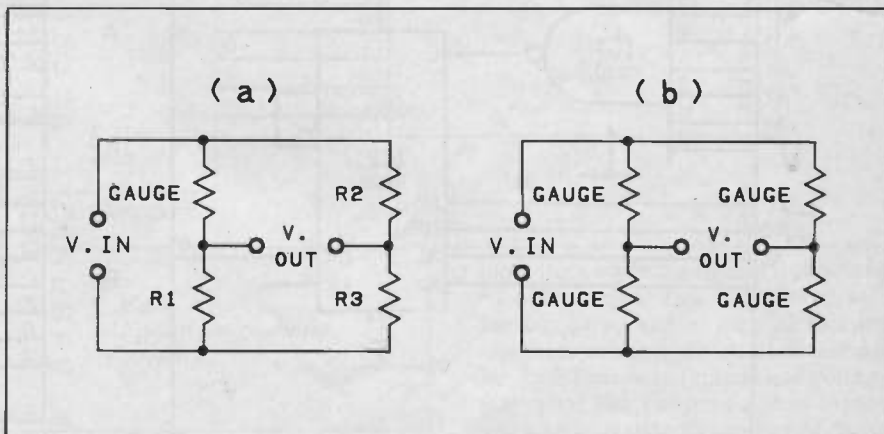
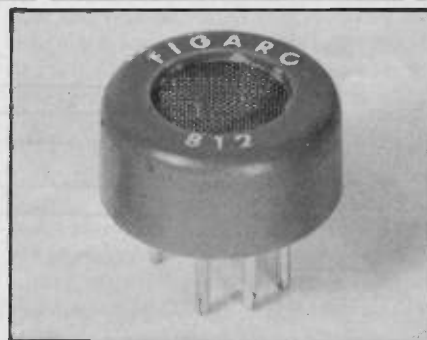

Fig. 8. (a) The quarter bridge measuring circuit and (b) the full bridge type.

Each gauge has what is termed a "gauge factor" ("K"), which is effectively a measure of its sensitivity. The gauge factor is given by the formula: $K \times r/R.E$. Where r is the change in resistance caused by applying strain E, and R is the resistance of the gauge with no stress applied. The higher the gauge factor, the greater the change in resistance for a given degree of stress. Typically the strain factor is only about 2, and the resistance through the gauge is around a hundred ohms or so.



AMSTRAD EPROM PROGRAMMERS

STEPHEN BURKITT

Simple design, inexpensive parts

The Amstrad's versatile sideways ROM is ideal for interfacing to an Eprom programmer. The I/O port can be used as an alternative.

CIRCUIT 1

THE AMSTRAD has a versatile sideways ROM ability yet the availability of Eprom programmers has been virtually nil. One or two are now appearing on the market, but are still extremely expensive. I therefore set out to build an inexpensive unit which would cater for the majority of Eproms, yet remain very simple and use only commonly available items. In fact, the whole prototype was built from surplus chips from my junk box.

The circuit is simple, requiring only an external variable power supply for the programming voltage. This can be easily constructed using the common single chip regulators. Fig.1. shows the wiring of the unit. The prototype was built on Vero V-Q prototype board, but any suitable type will do. The main part of the circuit revolves around the INTEL 8255 peripheral chip. This is a versatile circuit which can be programmed to almost any configuration to suit. The main use requires the chip to be in mode

0 which gives three eight bit ports, with port A, O/P, (low address), port C, O/P, (high address), and port B, data (set to input for verify and output for program). This is done by setting the control register (&80 for output and &82 for input). Bits 6,7 of port C are used as the chip select and program pulse respectively. In order to allow for different Eproms a customised jumper is used. A 14 pin header plug is suitable for this. The program supplied gives details of connections for various

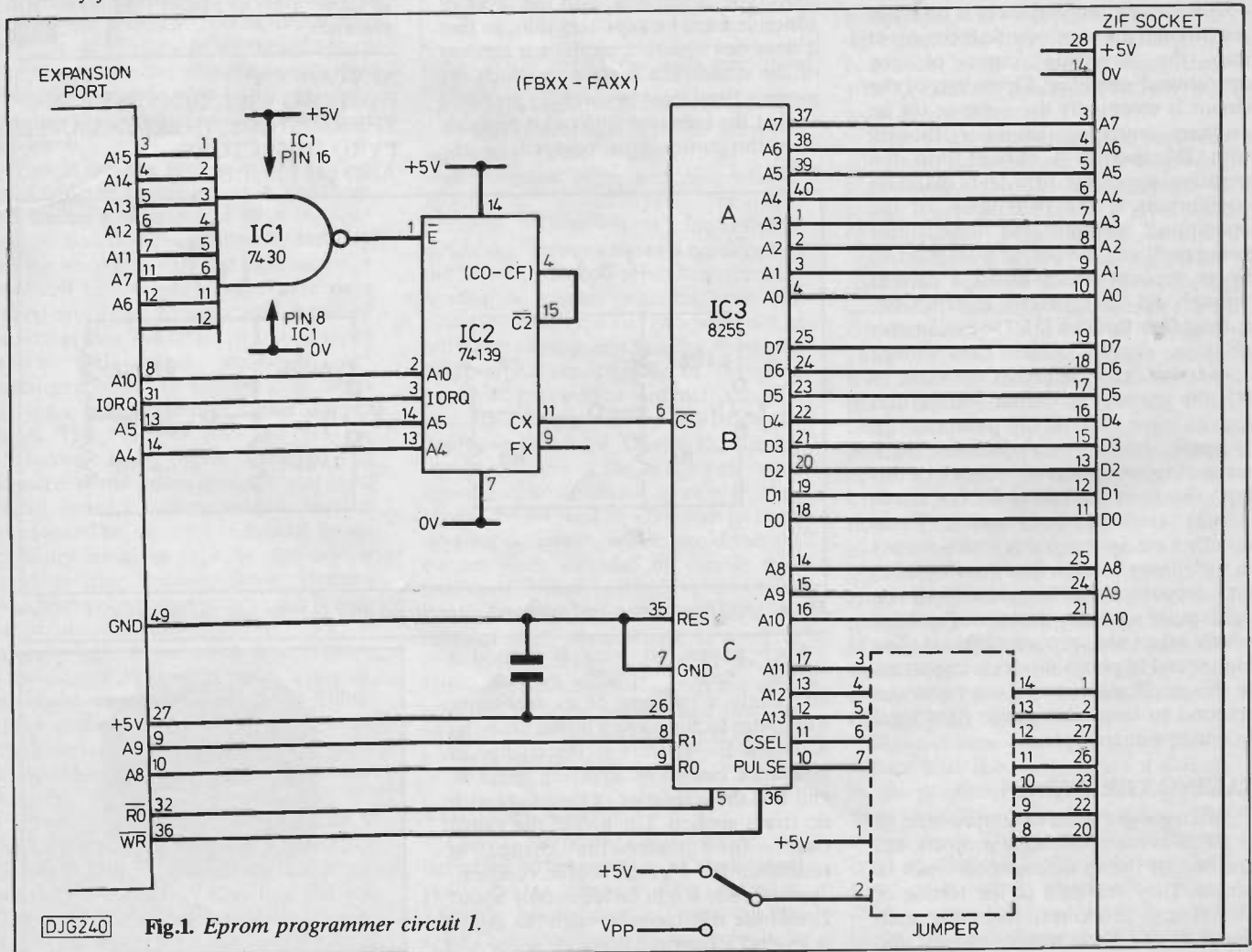

DJG240 Fig.1. Eprom programmer circuit 1.

Eproms. Address decoding is simple but conforms to the Amstrad specification. IC1 and IC2 give an I/O port base address of &F8E0. Use of a ZIF socket is recommended, but by no means essential. No protection is incorporated for incorrect insertion of Eproms so care must be taken in use.

CIRCUIT 2

The Amstrad I/O port (PE March 86) provides the Amstrad machines with a versatile port facility. One use of this would be as an Eprom programmer which can easily be achieved with just a few extra components. Along with a sideways ROM circuit board, this will

voltage regulator chips. A d.i.l. header is used to configure the p.c.b. for different Eproms. This may be left out if only one type will be used. Wiring for the jumper is displayed on the screen guide.

Programming consists of setting the required address and data on the Eprom

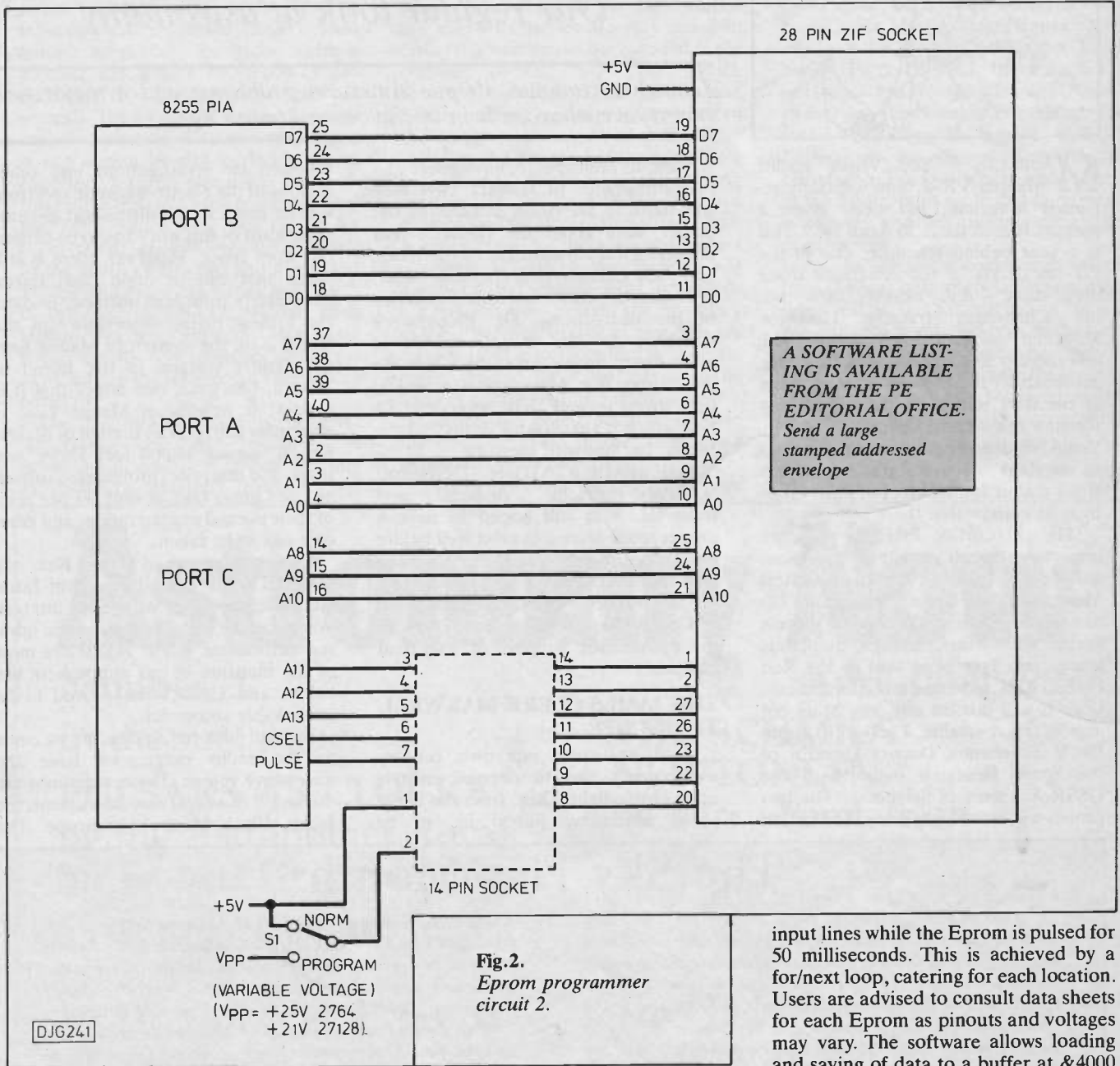

Fig. 2.
Eprom programmer circuit 2.

Construction is straight forward. Sockets are best used for all i.c.s., and decoupling capacitors fitted. The unit should be checked for shorts following assembly, and it is advisable to check voltages with the p.c.b. connected before finally fitting the i.c.s.

In order to allow for flexibility in development the software was written in Basic. Instructions on use are provided in the program. A buffer starting at 16384 (&4000) is used for the Eprom data, and is the default setting. A screen dump facility exists which can also be directed to a printer if required.

enable the avid programmer to transfer programs onto ROM for instant use. The Amstrad firmware manuals give details of ROM code layout.

Fig. 2. gives details of a suitable addition to enable programming of Eproms from the basic 2716 to the 27128. The 27256 could be used with minor adaption. Software written in Basic was used as speed was not essential. The modular layout will enable easy translation to assembler code if required. An external low current variable power supply is required, and can easily be made using standard

input lines while the Eprom is pulsed for 50 milliseconds. This is achieved by a for/next loop, catering for each location. Users are advised to consult data sheets for each Eprom as pinouts and voltages may vary. The software allows loading and saving of data to a buffer at &4000 (16384), with printout to screen or printer as required. Locations may be set individually or in block. Bytes not required for programming must be set to &ff (255) if they are in the middle of the programming block. Eproms may only be erased by ultra-violet light.

The listing is adequately REM'ed for information on each module and on screen guidance is provided. Entry of addresses is in decimal, with confirmation in hexadecimal. Pressing Return will normally give default addresses of &4000 to &4000+ Eprom size.

PE



SPACEWATCH

BY DR PATRICK MOORE OBE

Our regular look at astronomy

Launches continue, despite American problems; and a major new microwave telescope is in operation on Mauna Kea.

MAGELLAN – The Venus Radar Mapper VRM, now officially re-named Magellan, has been given a definite launch date: 25 April 1989. This is a year behind schedule, due to the various delays in the American space programme – most notably, of course, the Challenger tragedy. However, Magellan will definitely be dispatched, and there is one advantage in the delay, inasmuch as full use can now be made of the data sent back by the orbiting Russian space-craft, Veneras 15 and 16. Venus is indeed a curious world; whether or not there is active vulcanism there is still a matter for debate, but most investigators believe that there is.

THE PHOBOS PROBE Another important launch date has also been announced. In July 1988 Russia's latest Mars probes will begin their journey. Up to now the Russians have had no success at all with Mars, though numerous space-craft have been sent to the Red Planet. This new venture is ambitious, since it will take in not only Mars but also its larger satellite, Phobos. To quote Dr. V. Balebanov, Deputy Director of the Space Research Institute of the USSR Academy of Sciences: "The two probes will thoroughly study the Martian

surface, its atmosphere, ionosphere and magnetosphere. In January 1989 they will transmit television pictures of the planet, data about the chemical and mineralogical composition of the rocks, and their radiophysical characteristics." It is also hoped to solve the mysteries of the dust-storms. Dr. Balebanov's reference to the magnetosphere is interesting; up to now there are no indications that Mars has a magnetic field strong enough to be detectable – a lack which it shares with Venus and the Moon, but not with Mercury.

THE SPACE STATION – Despite all NASA's problems, financial and technical, it is still hoped to have a proper space-station in orbit well before the end of the 1990's. There has been one very encouraging sign: funding of 410,000,000 dollars has been guaranteed by Congress for the fiscal year 1987, with the enthusiastic support of President Reagan.

THE JAMES CLERK MAXWELL TELESCOPE

Until well into our own century, astronomers had to depend entirely upon visible light. Then, from the 1930s, radio astronomy joined in, to be

followed by investigations into other regions of the electromagnetic spectrum – even down to the ultra-short gamma-rays. Most of this work has to be carried out from space. However, there is still much that can be done from Earth, particularly from high altitude. To date, the loftiest major observatory in the world is on the summit of Mauna Kea, the extinct volcano in Big Island of Hawaii. (At least, one hopes that it is extinct; it neighbour, Mauna Loa, is extremely active!) The summit of Mauna Kea is almost 14,000 feet above sea-level, and this poses problems inasmuch as one's lungs take in only 39 per cent. of their normal oxygen ration, and great care has to be taken.

Of the telescopes of Mauna Kea, one – UKIRT, the United Kingdom Infra-Red Telescope – is of special interest. Water vapour is the enemy of the infra-red astronomer, but at 14,000 feet most of the moisture in our atmosphere lies below, and UKIRT has proved to be remarkably successful.

Beyond infra-red, and before we come to the radio range, we have the microwave region. These radiations are the target of a great new instrument, the James Clerk Maxwell Telescope. The

The Sky This Month

MARCH 1987 is not a good month for planetary observers. Venus, admittedly, is still a brilliant morning object, but it is well south of the celestial equator; the phase increases from 70 per cent. to almost 80 per cent., so that the planet is now gibbous. Mercury, the other inner planet, is too close to the Sun in the sky to be seen at all. Mars remains in the evening sky, but the apparent diameter has shrunk to less than 5 seconds of arc and the magnitude to +1.3, so that even powerful telescopes will show little surface detail. Jupiter sets soon after the Sun, and Saturn does not rise much before dawn. The Moon is full on the 15th, and new on the 29th.

The most interesting phenomenon is the solar eclipse of March 29th, which is "annular-total" – that is to say, annular along most of the track (so that a ring of sunlight is left showing round the dark disk of the Moon) and total briefly over a very restricted area. Totality will nowhere last for more than 8 seconds, and the eclipse will not be visible from the British Isles; the track begins in South America, crosses the South Atlantic Ocean, enters Africa near the Equator, and ends in the Indian Ocean. The partial phase can be seen from the extreme

south-eastern area of Europe. The eclipse begins at 10h 03m GMT and ends at 15h 35m. This is a bad year for eclipses; there are only two, both of the Sun – the minimum possible. The other, annular eclipse on 23 September, is also invisible from any part of Britain.

With the lengthening period of daylight we are starting to lose the brilliant winter constellations; Orion sets in mid-evening, and so does Sirius. Ursa Major, the Great Bear or Plough, is gaining altitude in the north-east, while Cassiopeia with its characteristic W-form, is descending in the north-west, though neither the Bear nor Cassiopeia ever sets over Britain. The main spring constellation – Leo, the Lion – has now become prominent, high in the south; it is easily recognisable by its bright leading star, Regulus, and the curved pattern which makes up the so-called Sickle. Following Leo round is Virgo, the Virgin. It has only one first-magnitude star, Spica, but is very rich in faint galaxies; indeed, it is here that we find the Virgo cluster of galaxies, around 60,000,000 light-years away, and far more populous than our own Local Group.

PI.

'dish' is 15 metres in diameter, and consists of 276 individual panels, so arranged to make up the correct paraboloidal figure. It has been a major engineering feat; the main components of the telescope and its control system were delivered during 1985, but it was not until 4 December 1986 that the first radio signals were received. The telescope was first pointed at our nearest natural neighbour, the Moon, with a receiver tuned to a frequency of 230 GHz (1GHz = 1,000,000,000 cycles per second). The Moon, of course, depends entirely upon reflected sunlight, but it is hot during its day period, and, as expected, a strong signal was received. Next came tests upon the planets Jupiter and Mars, which were well placed for observation. (Hawaii, remember, is well to the south of Britain, and at present Jupiter and Mars are a long way south of the celestial equator, so that from Hawaii they are high up). Once again strong signals were received, and so far as we can tell the telescope is functioning perfectly.

The microwave region is of great importance in all branches of astrophysics, and it is hoped that the James Clerk Maxwell telescope will

provide new information about star formation. At the moment we have a good idea of stellar evolution, but the very earliest stages – the condensation out of nebular material – are still uncertain, and microwave studies may fill in the gaps. There is, too, the microwave radiation which is coming in from all directions all the time. Unless our current theories are very much in error, this microwave background is the remnant of the "big bang" which occurred between 15,000 million and 20,000 million years ago – the birth of the universe as we know it today.

Before the detection of the microwave background, there was still strong support for the 'steady-state' theory, championed by Hoyle, Bondi and Gold, according to which there was no moment of creation, so that the universe has always existed and will exist forever; as old galaxies pass beyond the boundary of the observable universe, new ones are formed from material which is spontaneously created out of nothingness in the form of hydrogen atoms. It was, in fact, the microwave background which gave the coup de grâce to the steady-state hypothesis.

The James Clerk Maxwell Telescope

– named after the great Scottish scientist of the last century – is largely British, with contributions from Holland. The Rutherford Appleton Laboratory at Chilton in Oxfordshire, in close collaboration with Cambridge University, was responsive for the design, development, construction and commissioning; there have been major contributions from Queen Mary College, Kent University and the Royal Observatory Edinburgh. From Holland, the main collaboration has come from Utrecht University, the National Foundation for Radio Astronomy Dwingeloo, and the Laboratory for Space Research in Groningen. The Dutch have always been in the forefront of radio and microwave astronomy, and they are maintaining this position now.

As the telescope comes into operation, we can only speculate as to what it will tell us, but without a doubt it will provide important advances in the near future – with the added advantage of being close to UKIRT and the various optical telescopes now scattered on the heights of Mauna Kea. It is an exciting prospect.

PE

Astronomy Now

Number. 1

April-June 1987

In the first issue:

PULSARS AS CLOCKS
by the Astronomer Royal,
Sir Francis Graham-Smith

**THE BIZARRE WORLD
OF MIRANDA**

by Dr. Garry E. Hunt

**FIRST STEPS IN
ASTROPHOTOGRAPHY**
by H.J.P. Arnold

**THE WILLIAM
HERSCHEL SOCIETY**
by A.V. Sims

**THE SCHMIDT-
NEWTONIAN**
by Barry Pemberton

plus a host of regular
features, including:

The Night Sky this Quarter
Reviews of Books and
Instruments
Society News
Letters and Comments
Latest Astronomical News
from Around the World
Observers' Page

Available from March 17th at all good newsagents Price £1.25

PE 30 PLUS 30

PART THREE BY GRAHAM NALTY

An amp of excellence!

In this concluding part of the very high quality PE 30+30 amplifier, the power supply, wiring and a few points arising are discussed.

SINCE part one of the PE 30 + 30 was published, a few points have arisen that need further discussion.

In the first instance, I note with interest Robert Penfold's comments about the noise on high level inputs with the volume control at minimum. In my experience, amplifiers with tone controls and their circuitry are more noisy than those without them. It is quite possible that using a polycarbonate capacitor for C22 allows more hiss through than a polyester one, and even more than the commonly used electrolytics. If any readers have any ideas on reducing the noise of the tone control stage without sacrificing sound quality, I would be interested to know.

The arrangements for the output stage may cause a little confusion, so I will explain in a bit more detail. The standard 30 + 30 uses one pair of output transistors per channel with OR15 wirewound resistors connected to each emitter (R49 and R50). The use of a low value for these resistors reduces distortion, but is dependant on the close thermal tracking between the bias transistor Tr19 with Tr20 and Tr21, which should be placed only in the positions shown on the component overlay. If you wish to build a high current version with two pairs of output transistors, then the thermal tracking between the outer transistors and bias transistor is reduced and a larger value of emitter resistors recommended. This is provided by two 1 Ohm resistors in parallel, which should be at least half watt rating, and preferably one watt. The Holco resistors suggested for the improved version result in a large improvement in sound over standard metal film or wirewound resistors. The power rating of TIP131 and TIP136 is 70 watts, and is lower than the other recommended types. Whilst they are satisfactory when used in pairs in a high current version, the higher power types are more suitable in the standard 30 + 30.

Some transformers for audio amplifiers can produce audible mechanical noise when the amplifier is playing. The transformers supplied with PE 30 + 30 kits are specially manufactured for low noise, though cost a little more.

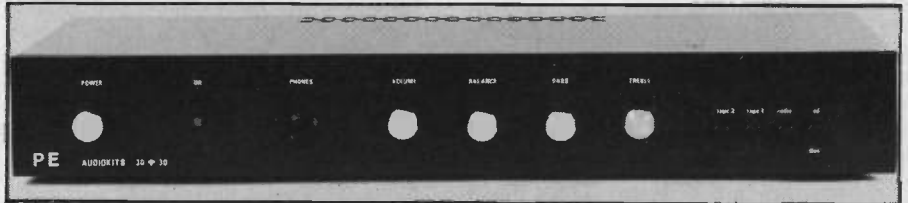

The standard 30 + 30 can be increased in power by changing the transformer secondary from 22v-0-22v to 25v-0-25v, but at the same time, capacitors rated at 35v should be changed to 40v, the output transistors doubled up, and their emitter resistors changed from one OR15 to two pairs of 1R0 in parallel. Also, it is a good idea to increase the reservoirs C35 and C36 from 6800, μ F to 10,000 μ F. Each reservoir capacitor should be attached to the case by two nylon cable ties.

Cable lengths are shown primarily for constructors using high performance audio cables which may cost several pounds per metre length. The most suitable audio quality cable for internal wiring is Kimber cable which is available in three colours, red, blue and black. Where two colours are shown above, the first colour is used on standard kits and the second is the recommended colour

when using Kimber cable. Kimber cable is directional (its sounds better one way), and the arrow markers on the cable should point in the direction from cartridge to speaker, or from power supply to circuitry.

CORRECTIONS

PE Feb 87, page 43, Fig.2. The left hand end of R34 should be connected to the emitter of Tr8, and not to Tr9, Tr10 and Tr13. The bottom end of R30 should not be connected to the junction of R32 and R33.

PE March 87, page 50. Add R68 and R69 after R59. Delete R65 and D31. Add: R48/10 Ohms $\frac{1}{2}$ w metal film/10 Ohms Holco H2 1W. For improved version: C21 use 47OpF EXFS/RP. C35/C36 FILMCAP DNM can be substituted. C2 use 8nF EXFS/RP. IC2 use MC7815CT.

Page 51. Add R63 prior to R64. **PE**

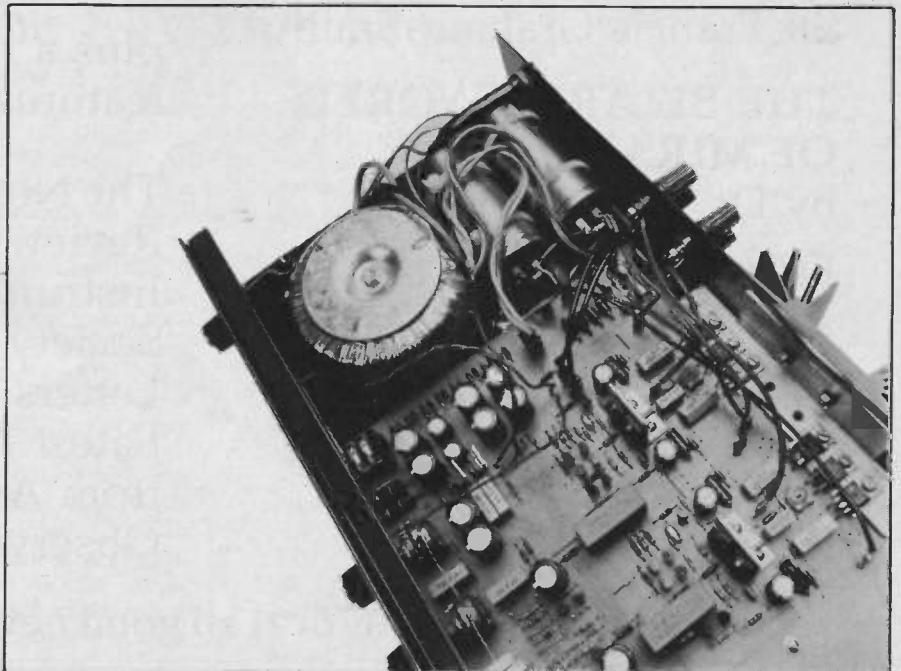
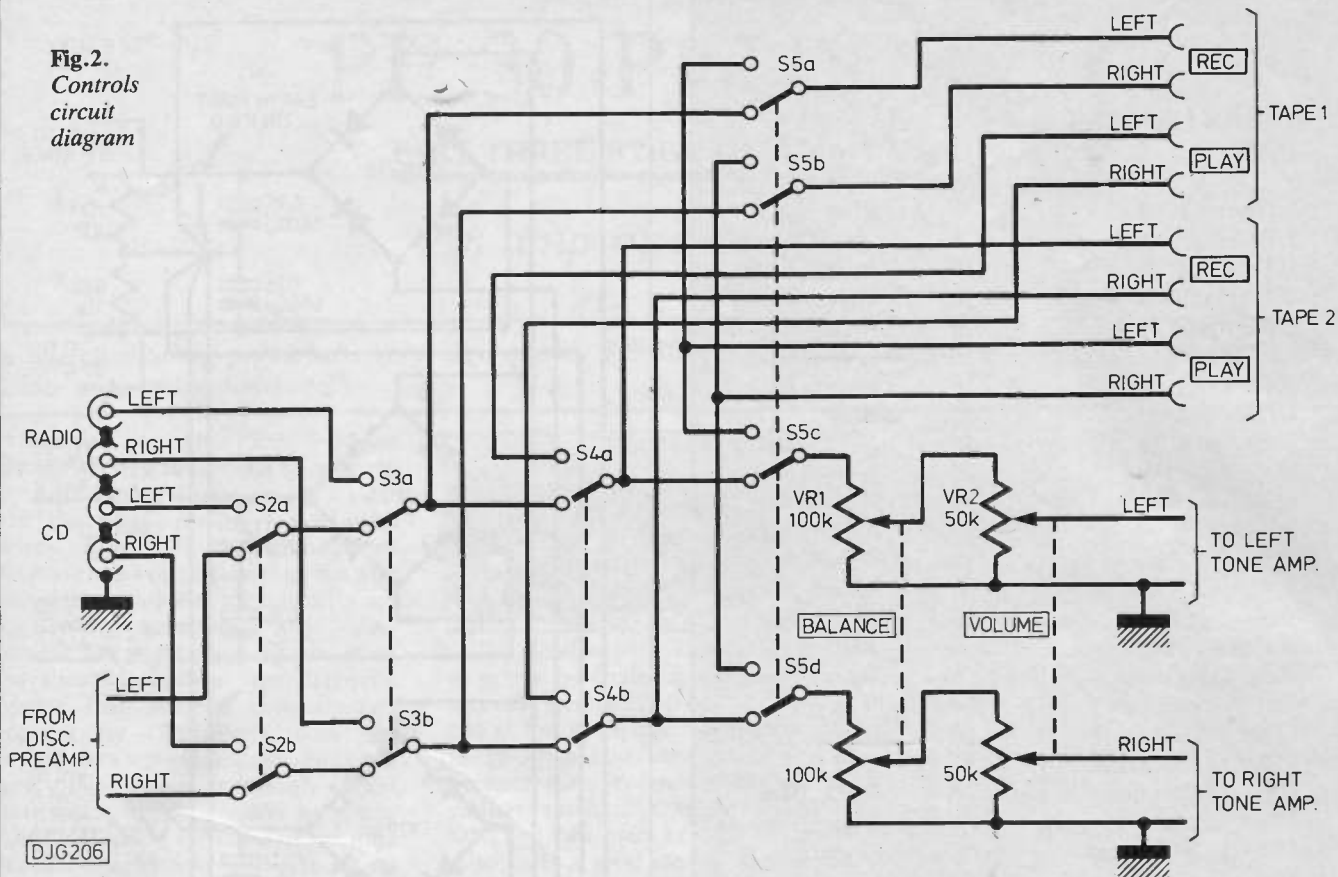

Fig.2.
Controls
circuit
diagram



DJG206

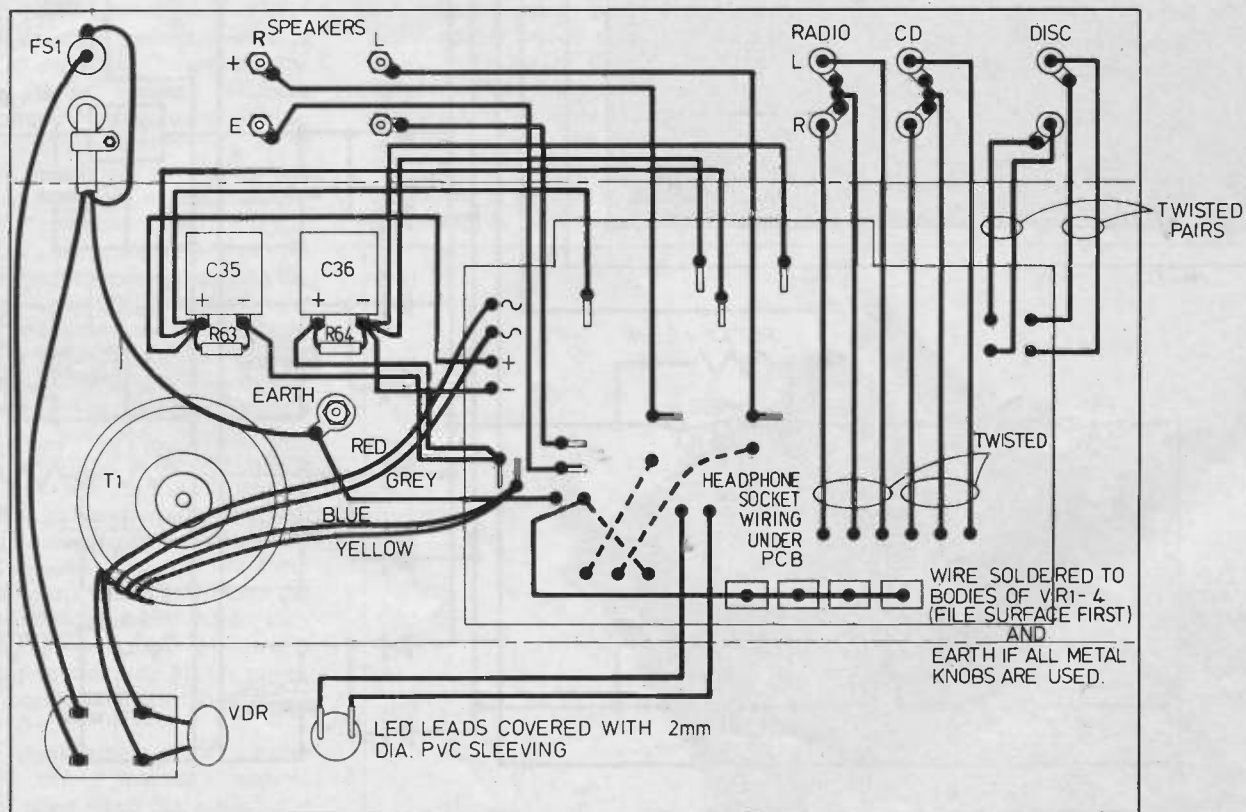

Fig.3. Wiring diagram

DJG242

1987 CATALOGUE

Out now!! Bigger and better than ever - 80 pages packed with components and equipment from humble resistors to high tech scopes! Bargain List, Order Forms and £1.50 Discount Vouchers all included for just £1.00 inc. post.

sinclair MICROVISION

We have a large quantity of the PCB from this innovative flat screen TV. They are, however, incomplete with the main chip, tuner and vol control missing. This means of course they won't cost a lot. By the time this ad appears we'll have more information, so ring or write for details.

POWER SUPPLIES

Z993 65 Watt switch mode multi-output power supply. Astec Model AA12790. Offered at around one-third normal price, this has to be the Bargain of the Year!! Compact unit 195x105x50mm accepting 115/230V ac input. Outputs:

+5V 3A
+12V 2.9A
+18V 1.0A
-5V 0.2A

£29.95

Z468 Switched mode PSU by Europower, model EP3008/MMS. Eurocard size 160x100mm. 230V input, 5V at 3A and 12V at 1/2 A output. Excellent value. **£19.95**

Z975 Power Supply Unit. As used in 'Teach in 86'. Built in 13A plug. Case 92x57x45mm. Output 14V at 600mA AC **£3.50**

Z482 Siliconix mains input, 4.5V DC 150mA output to 3.5mm jack plug on 2m lead. Built-in continental 2-pin plug. Size 62 x 46 x 35 **£1.50**

Z483 NI-CAD Panel 177x144mm PCB with one massive Varta Deac 57x50mm \varnothing rated 7.2V 1000MAH and another smaller Deac 32x35mm \varnothing rated 3.6V 600mA. The price of these Ni-cad stacks new is over £20. Also on the panel is a mains input charger transformer with two separate secondaries wired via bridge rectifiers, smoothing capacitors and a relay to the output tags. The panel weighs 1kgm... All this for just **£6.00**

Z470 COMPONENT UNIT. Panel 130x165mm with 10 x 74 series IC's, all in sockets, R's, C's etc inc 100uF 16V tant. Also 5A DPCO relay and 6 brass pillars 60mm long supporting a steel panel upon which is mounted a mains transformer giving 5V and 12V output; 7805KC regulator and a screened box 110x80x30mm with phono input containing 76131 stereo pre-amp IC + associated components. Various plugs and sockets. Amazing value - components must be worth over £50. Yours for just **£4.50**

KEYBOARDS

TATUNG VT1400 Video Terminal Keyboard Brand new cased unit 445x225x65/25mm 71 Alpha-numeric and function keys, + separate 14 key numeric keypad. ASCII output via curly cord and 6 way plug. Data and connexion sheet supplied. Now only **£17.50**

COMPUTERS LYNX keyboard 58 full travel keys size 334 x 112 mm Brand new Reduced to **£5.95**

Z475 TRIAC PANEL - 240 x 165mm. 14 triacs 2N6346, TXAL116B or sim. 200V 6-8A; 16 SCR's C106A1 4A 30V; 6 x 4099 in skts; 15 suppressors; 37 ZTX450; min 12V relay; R's C's plugs etc. Only **£4.50**

'NEWBRAIN' PANELS

Z494 Motherboard microprocessor panel 265x155mm Complete PCB for computer. Z80, char EPROM etc. 68 chips altogether + other associated components, plugs, skts etc. **£5.50**

Z495 RAM panel. PCB 230x78mm with 14 x MM5290-2 (4116) (2 missing) giving 28k of memory. Also 8 LS chips. These panels have not been soldered, so chips can easily be removed if required **£5.00**

'NEWBRAIN' PSU

BRAND NEW Stabilized Supply in heavy duty ABS case with rubber feet. Input 220/240V ac to heavy duty transformer via suppressor filter. Regulated DC outputs: 6-5V at 1-2A; 13-5V at 0-3A; -12V at 0.05A. All components readily accessible for mods etc. Chunky heatsink has 2 x TIP31A. Mains lead (fitted with 2 pin continental plug) is 2m long. 4 core output lead 1.5m long fitted with 4 pole skt on 0.1" pitch. Overall size 165x75x72mm. **£5.95** 10 for **£40**

FLASH UNIT

Z488 Complete apart from case. Xenon tube, neon indicator, on/off switch, trigger wires. Requires 3V supply, 50x55x30mm Brand new, with data **£2.70**

RECENT ADDITIONS

Full details in Bargain List 27

CB MICROPHONE

Hand held with push to talk switch. Curly lead. 600R Dynamic **£2.95**

CIRCUIT TEST

DC continuity tester. Needs 2xAA cells. 90cm long lead has croc clip. **50p**

MINI DRILL

Precision geared plastic. Brass chuck takes up to 1.2mm bit. Storage in handle. 115mm long. **£1.69**

TELEPHONE

Non-BT approved single piece. Push button with auto redial. Ivory. Wall bracket. 4m lead (half is coiled) ... **£5.99**

CRAFT KNIVES

Miniature type has 12 snap off sections. 9mm wide blade is fully retractable and can be locked in position. Supplied with spare blade. 125mm long. **50p**
Heavy duty version of above - 18mm wide blade, 7 sections, 150mm long. **95p**

LOGIC PROBE

For TTL, CMOS etc. LED and sound indication. Pulse enlargement capability allows pulse direction down to 25nsec. Max f = 20MHz **£9.99**

STEREO TUNER

Z497 AM/FM STEREO TUNER PANEL. Complete radio chassis with push button selection for LW/MW/FM and ON/OFF. Ferrite rod for LW & MW selection, co-ax socket for FM aerial. Supplied with mains transformer and rectifier/smoothing cap, and wiring details. PCB is 333x90mm. **£12.95**

ABS MULTIPURPOSE BOXES

Easily punched or drilled. The 6 larger sizes have brass inserts into which screws fit holding the lid in place. The 2 smaller sizes use self tappers. PCB slots. Black

V207	71 x 46 x 22mm	60p
V208	107 x 53 x 18mm	80p
V210	75 x 56 x 35mm	100p
V213	95 x 71 x 35mm	109p
V216	115 x 95 x 37mm	135p
V217	145 x 95 x 55mm	184p
V218	207 x 122 x 77mm	345p
V219	214 x 143 x 57mm	295p

**HAVE A
3 DAY BREAK
on
GREENWELD!
FULL DETAILS
IN CATALOGUE**

All prices include VAT; just add 60p P&P. Min Access order £10. Official orders from schools etc. welcome - min invoice charge £10. Our shop has enormous stock of components and is open 9-5.30 Mon-Sat. Come and see us!!

443C Millbrook Road Southampton
SO1 0HX Tel (0703) 772501/783740

**GREENWELD
ELECTRONIC
COMPONENTS**

**For KITS & COMPONENTS -
Choose the easy way - with
Send 50p* & SAE
for CATALOGUE**

ORDERS: RING (01) 567 8910 - 24 HRS.

HIGH SECURITY LOCK KIT POWER STROBE KIT



Designed for use with our lock mechanism (701 150) this kit will operate from a 9V to 15V supply drawing a standby current of only 50uA. There are over 5000 possible 4-digit combinations and the sequence can be easily changed. To make things even more difficult for an unauthorised user an alarm can be sounded after 3 to 9 incorrect entries - selectable by means of a link. The alarm can sound for a few seconds to over 3 minutes during which time the keyboard is disabled preventing further entries. A latched or momentary output is available making the unit ideal for door locks, burglar alarms, car immobilisers, etc. A membrane keyboard or pushbutton switches may be used and a beep sounds when a key is depressed. Kit includes high quality PCB, all components, connectors, high power piezo buzzer and full assembly and user instructions.

XX121 LOCK KIT **£15.95**
350 118 Set of keyboard Switches **£4.00**
KB12S 12-Way Membrane Keyboard **£9.98**
701 150 Electric Lock Mechanism **£16.50**

MICROPROCESSOR TIMER KIT

Designed to control 4 outputs independently switching on and off at preset times over a 7-day cycle. LED display of time and day, easily programmed via 20 way keyboard. Ideal for central heating control including different switching times for week-ends). Battery back-up circuit. Includes box. 18 time settings.

CT600K **£42.90**
XX114 Relay Kit for CT6000 includes PCB, connectors and one relay. Will accept up to 4 relays. 3A/240V c/o contacts **£4.30**
701 115 Additional Relays **£1.80**

VERSATILE REMOTE CONTROL KIT

This kit includes all components (+ transformer) to make a sensitive IR receiver with 16 logic outputs (0-15V) which with suitable interface circuitry (relays, triacs, etc - details supplied) can be used to switch up to 16 items of equipment on or off remotely. The outputs may be latched (to the last received code) or momentary (on during transmission) by specifying the decoder IC and a 15V stabilised supply is available to power external circuits. Supply: 240V AC or 15-24V DC at 10mA. Size (excluding transformer) 9 x 4 x 2 cms. The companion transmitter is the MK18 which operates from a 9V PP3 battery and gives a range of up to 60ft. Two keyboards are available MK9 (4-way) and MK10 (16-way), depending on the number of outputs to be used.

MK12 IR Receiver (incl. transformer) **£14.85**
MK18 Transmitter **£7.50**
MK9 4-Way Keyboard **£2.00**
MK10 16-Way Keyboard **£5.95**
601 133 Box for Transmitter **£2.60**

Designed to produce a high intensity light pulse at a variable frequency of 1 to 15Hz, this kit also includes circuitry to trigger the light from an external voltage source (eg. a loudspeaker) via an opto isolator.

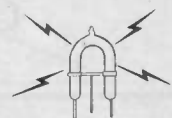

Instructions are also supplied on modifying the unit for manual triggering, as a slave flash in photographic applications or as a warning beacon in security applications. The kit includes a high quality pcb, components, connectors, 5Ws strobe tube and full assembly instructions. Supply: 240V ac. Size: 75x50x45.
XX124 Stroboscope Kit **£12.50**

8 WAY SEQUENCER KIT

The DL8000K is an 8-way sequencer kit with built in opto-isolated sound to light input which comes complete with a pre-programmed EPROM containing EIGHTY - YES 80! different sequences including standard flashing and chase routines. The KIT includes full instructions and all components (even the PCB connectors) and requires only a box and a control knob to complete. Other features include manual sequence speed adjustment, zero voltage switching, LED mimic lamps and sound to light LED and a 300W output per channel.

And the best thing about it is the price:
ONLY £28.50



DISCO LIGHTING KITS

DL1000K This value-for-money 4-way chaser features bi-directional sequence and dimming. 1kW per channel. **£17.50**
DLZ1000K - A lower cost uni-directional version of the above. Zero switching to reduce interference. **£9.85**
DLA1 Optional opto input allowing audio 'beat' light response **70p**
DL3000K -3-channel sound to light kit features zero voltage switching, automatic level control and built-in microphone. 1kW per channel. **£14.25**

DVM/ULTRA SENSITIVE THERMOMETER KIT

Based on the ICL 7126 and a 3/2 digit liquid crystal display, this kit will form the basis of a digital multimeter (only a few additional resistors and switches are required - details supplied), or a sensitive digital thermometer (-50°C to +150°C) reading 0.1°. The kit has a sensitivity of 200mV for a full-scale reading, automatic polarity and overload indication. Typical battery life of 2 years (PP3). **£17.00**



**TR ELECTRONICS
13 BOSTON RD.
LONDON W7 3SJ
Tel: 01 567 8910**

**SEND 9" x 6" SAE & 50p FOR
CATALOGUE OR CALL AT
SHOP Mon-Fri 9-5 pm
Saturday 10-4 pm**

**ORDERING INFORMATION:
ALL PRICES EXCLUDE VAT**

FREE P&P on orders over £20 (UK only), otherwise add 75p + VAT. Overseas P&P: Europe £2.75. Elsewhere £6.50. Send cheque/PO/Barclaycard/Access No. with order. Giro No. 529314002.

**LOCAL AUTHORITY AND EXPORT ORDERS WELCOME
GOODS BY RETURN SUBJECT TO AVAILABILITY**

DIRECT CURRENT MOTORS

PART TWO BY BRIAN BROOKS

Characteristics, performance & control circuits.

In the second part, this article looks at passive and active central circuits for small D.C. motors.

IN PART ONE of this article the relationships between voltage, current, torque and speed were established for d.c. motors. In this part of the article various methods of motor control will be demonstrated which make use of these relationships.

SIMPLE SYSTEMS

A) Series Resistance

The simplest form of motor control is that used in model railways and racetracks – the series resistor. Fig.1. shows the circuit and the torque/speed curves for various values of series resistance. Note first of all that the external series resistor limits the motor performance in exactly the same way that the internal motor resistance does. The effect on the torque and speed characteristics is shown in Fig.1. (a) and (b) for several values of RV. The most obvious feature of Fig.1. (a) is that the motor is controlled indirectly by the effect of the torque/speed characteristics of the motor load. An idealised load-line is shown in Fig.1. (a). The motor speeds corresponding to the various settings of RV for this particular load are found by the intersection of the load-line and the torque/speed lines. With the ideal load shown the speed control is quite reasonable. It is non-linear, but because the best control is obtained at low speeds, this is an advantage in model applications. The same motor curves are shown in Fig.1. (b) but this time with a more realistic 'imperfect' load. This load has an initial starting torque requirement to overcome the static frictional forces and additional non-linear 'stiction' forces which resist the initial movement of the motor. Once the motor begins to move, the stiction forces drop to zero and the motor requires less torque than the starting torque to run slowly.

This non-linear behaviour at low speeds exists in all systems but is particularly evident in smaller motors using simple bearings and brushes. The effect is a familiar one to those who have played with model trains. The controller

must be advanced to a certain point before the train will start, whereupon the train speed jumps abruptly (and unrealistically) to a 'minimum start speed'. Fig.1. (b) shows this effect very clearly by the intersection of the motor torque/speed curve for $RV = 1$ OR (approximately) with the load line. The two points of intersection are the starting torque and the 'minimum start speed' respectively. Above the minimum start speed the imperfect load is controlled reasonably well. Note also that once the motor has started, it is possible to reduce the speed below the minimum start speed by backing off the controller, i.e. increasing RV. This is another technique with which the model railway enthusiast will no doubt be familiar.

All that has been considered so far is a simple load with constant torque/speed characteristics. If the motor load conditions change, for example due to a model train encountering a gradient, the motor speed and torque will change to meet the new load-line. Fig.2. shows two possible load lines crossing a slow speed setting from the graphs of Fig.1., ($RV = 2R$ approx). The new 'Higher Load' demands an increased torque which is obtained at a lower speed where the new load-line crosses the torque/speed line. Although the extra torque required is quite modest, the speed falls to almost half. At lower torque settings the effect is even worse and the motor speed varies widely in response to load changes. This method of control is very limited and has very few advantages other than simplicity.

B) Variable Voltage

The second method of motor control is far superior to the series resistance method, but is more complicated. The extra complication is not very important now that monolithic voltage regulators and high gain power transistors are available. As the name implies, the motor is fed with a variable voltage from a low impedance source.

Fig.3a. shows the performance curves for several values of motor voltage. V_1 is the standard terminal voltage and the

motor torque/speed characteristic is exactly the same as in Fig.1. where $RV = 0$. At lower voltages V_2, V_3 , etc. the stall-torque and the no-load speed both decrease and a set of parallel torque/speed curves results. When the two load-lines from Fig.2. are drawn, the improved performance is shown immediately by the larger increase in torque, accompanied by a smaller decrease in speed. This is closer to the ideal characteristic where a large increase in torque would produce no change in speed.

There are two other advantages of this method. The first is that the motor speed is linearly related to the applied voltage. This is helpful when motors are used as simple drive systems, because fixed-ratio voltage dividers can be used to provide a range of speeds.

The second advantage – attention model railway enthusiasts – is that the low speed performance is improved and the 'Minimum Start Speed' of the real load in Fig.2b. is greatly reduced. Fig.3b. shows this improvement graphically. The extra complication of this method of control is its main disadvantage.

One other disadvantage is that at low speed settings there is only a small voltage applied to the motor. This can give rise to problems when there is poor contact between the brushes and the commutator due to wear, corrosion, or design economies. In some circumstances the voltage applied will be unable to break down the surface contamination, with the result that the motor will not start. This contrasts with the series resistance method of control where the full supply voltage is available and appears instantly across any high resistance contacts – even at low speed settings.

These two simple methods of control are adequate in themselves for some simpler motor control applications. Neither of them can pretend to offer anything like 'constant speed' performance, and low speed running can only be obtained by means of low

D.C. MOTORS

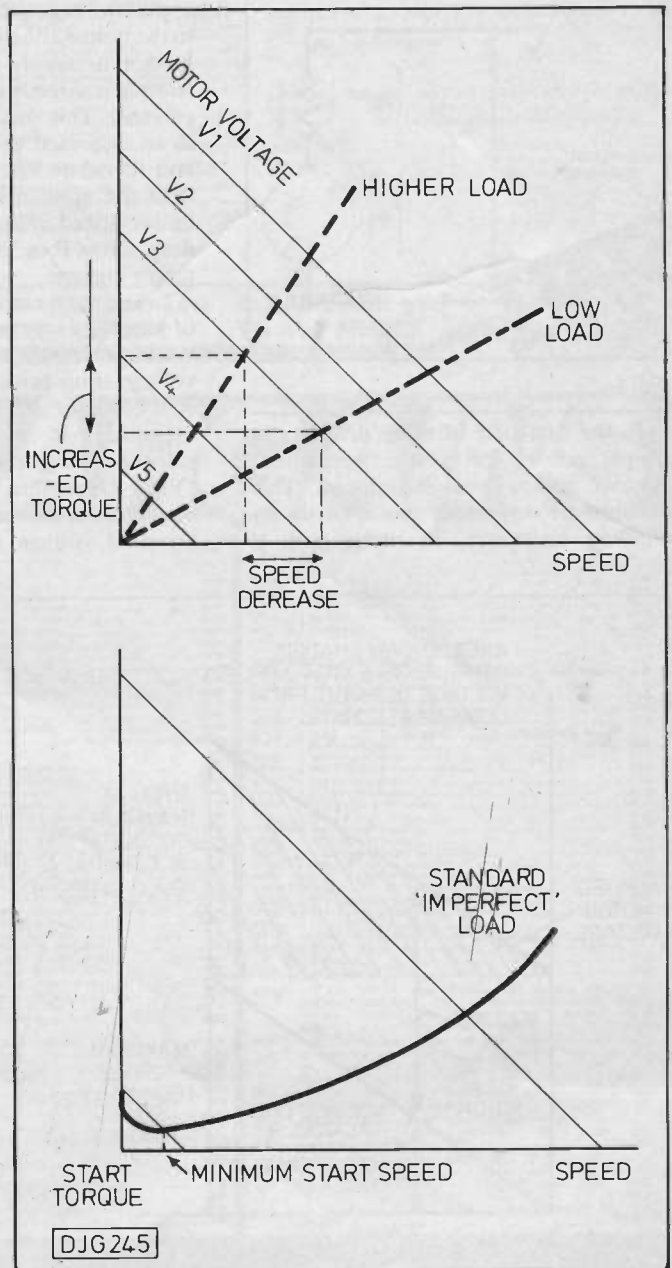
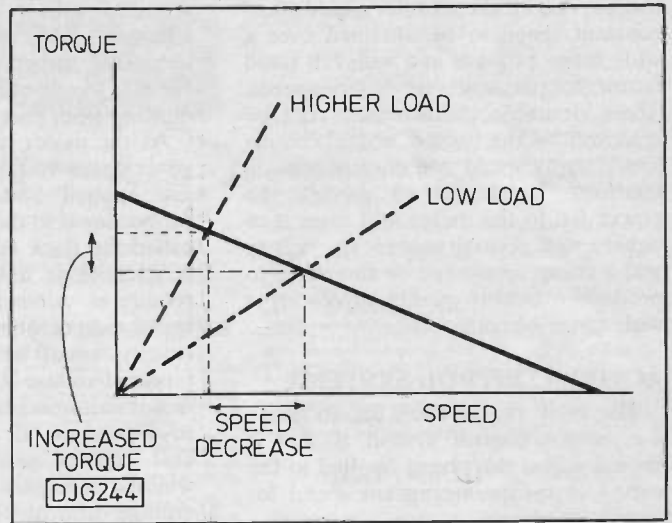
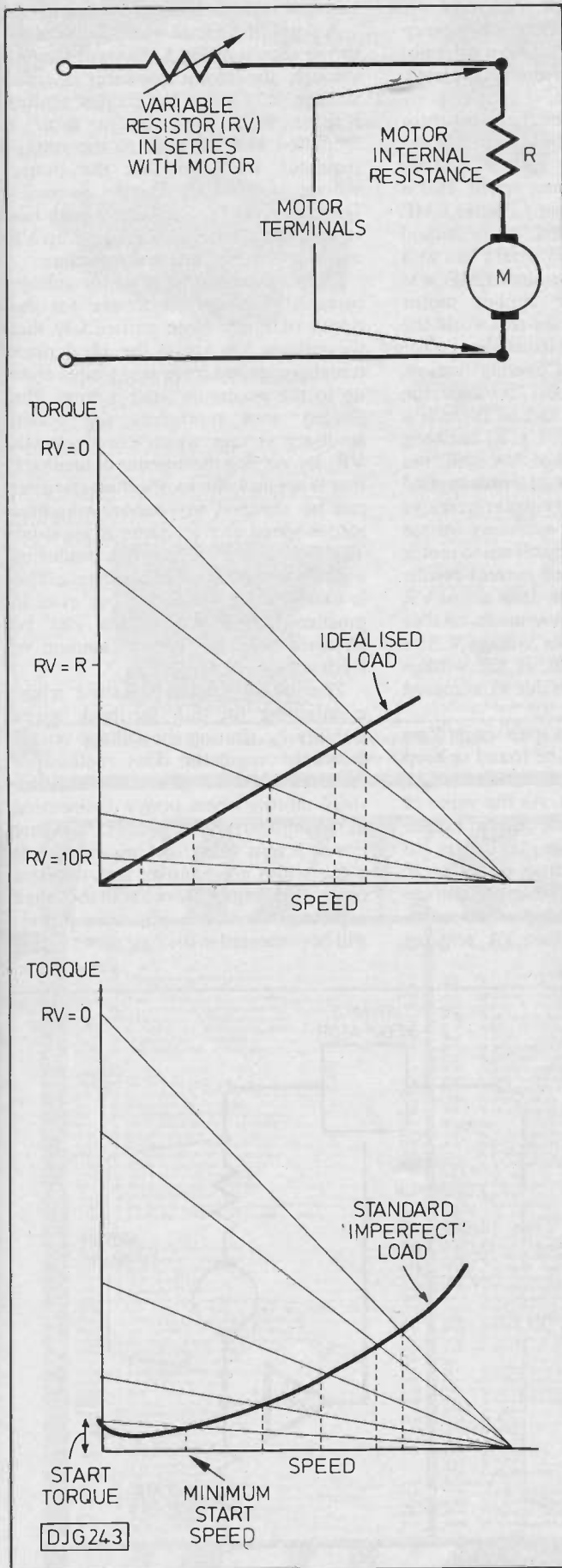

Fig.2. (Top) Effect of changing load.

Fig.3. (Bottom) Variable voltage speed control.

torque. The ideal controller would allow constant speed to be obtained over a wide range of loads and with full rated motor torque available at all speeds. These desirable characteristics can be achieved by the use of 'active' circuits which apply speed and current sensing feedback techniques to modify the power fed to the motor and force it to behave well. A small amount of circuitry and a cheap motor can be combined to produce excellent quality drives for a wide range of applications.

ACTIVE CONTROL SYSTEMS

The main requirement for an active d.c. motor control system is that it should adjust the power applied to the motor to maintain constant speed for varying loads.

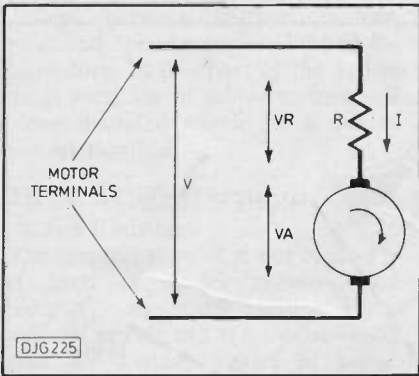

Fig. 4.

In the first part of these articles the simple model for a d.c. permanent magnet motor was introduced. This consists of a perfect motor with no winding resistance, in series with a

separate resistor which represents the effective total winding resistance measured across the motor terminals. Fig. 4. is a repeat of the model schematic drawing from part one.

As the motor rotates the ideal rotor generates a voltage VA which opposes the applied voltage and is directly proportional to the motor speed. This is called the Back EMF or Counter EMF. A frictionless unloaded motor would require no current and would run at a speed where the counter EMF was exactly equal to the applied motor terminal voltage V. In the real world the motor requires current to produce power to oppose the air and bearing friction. This current must pass through the winding resistance R and so there is a voltage drop of $VR = I \times R$ between the ideal rotor voltage VA and the applied voltage V. If a load is now applied to the motor, the motor current increases further to supply the necessary torque (torque is directly proportional to motor current). This increased current results in an increased voltage drop across VR and therefore VA is now much smaller than the applied motor voltage V. The motor speed thus falls as the voltage drop across R increases due to increased motor current.

To maintain constant speed regardless of torque, a way must be found to keep VA constant with motor current and the voltage drop across R. As the value of R is constant and motor current can be measured, it is a simple matter to calculate the voltage dropped across R (VR). Once this is known, a voltage equal to VR can be added to the motor terminal voltage so that VA remains

constant regardless of motor current.

A simplified circuit which will achieve this is shown in Fig. 5. Current flowing through the motor produces a small voltage drop across the current sensing resistor RC. This voltage drop is amplified and fed back to the voltage regulator REG so that the output voltage rises as the current increases. The degree of this increase is such that it exactly equals the Voltage drop VR across the motor internal resistance.

Fig. 6. shows the ideal motor voltage curve plotted against torque for the circuit of Fig. 5. Note particularly that the voltage VA across the ideal rotor remains constant from zero torque right up to the maximum 'stall' torque. The shaded area represents the added feedback voltage which exactly equals VR. By varying the amount of feedback that is applied, the motor characteristics can be changed to produce whatever torque/speed characteristic is required. The feedback level shown is producing a 'neutral' constant speed-response. This is idealised for simplicity, but even in practice very good results can be obtained with the correct amount of feedback.

The motor speed is varied whilst maintaining the full feedback speed stability by altering the voltage output from the regulator. This method of feedback control is practically ideal for small motors where power dissipation in the regulator is manageable. At higher power levels, other techniques such as pulse width modulation and thyristor control are better. More about these and a practical feedback controller project will be presented in the next part. **PE**

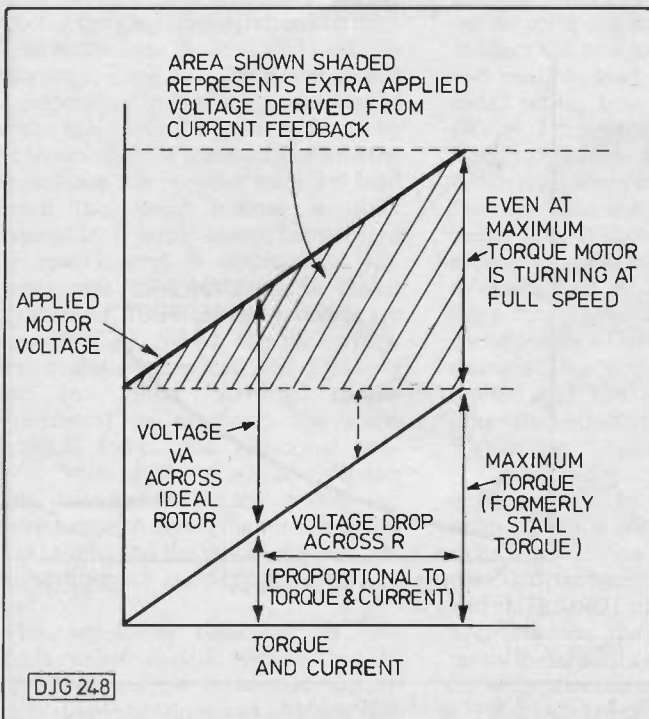

Fig. 5. Current feedback simplified circuit.

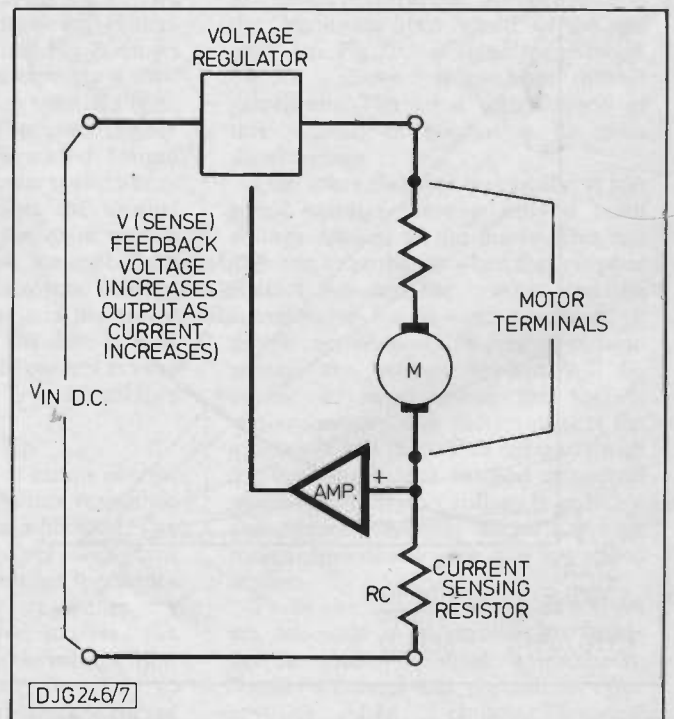
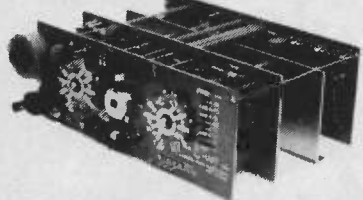

Fig. 6. Current feedback circuit voltage characteristics.

JLH

LINSLEY-HOOD SYNCHRODYNE AM RECEIVER

Very high quality kit for this recent design featured in 'Wireless World'. Advanced construction system, approved by the Author, uses 3 double sided PCBs in a stacked layout for total stability, ease of construction and minimal wiring. This module will form the AM section of an ultra high quality AM/FM switched bandwidth tuner to match our 300 series amplifiers. Power supply and tuning gang will be included with the FM section. £59.95



VFL600 VERTICAL FRONT LOADING CASSETTE MECHANISM

This latest addition to our range fulfils the need for a reasonably priced front loading cassette mechanism. This unit comes complete with stereo R/P and erase heads having standard mountings so that they may be exchanged for others in our range of heads if required. The mechanism also has a 3 digit counter, chrome operating keys, mechanical auto stop and a removable decorative cassette door with central window and key functions marked below. Cassette door/corner has a hydraulically damped 'soft eject' feature. Motor is internally governed and only needs a 12v DC supply with an average current of 80mA. Overall size 160mm wide including counter, 100mm high and 85mm deep including motor and keys. A robust and thoroughly useful deck for many purposes. £24.30

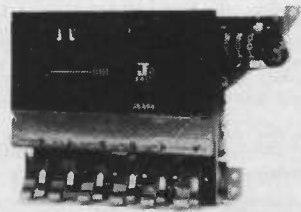

CAR RADIO FM IF AND STEREO DECODER

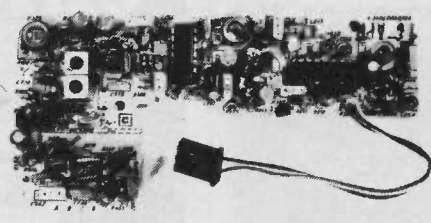

Miniature PCB with 10.7MHz ceramic filters. 2-transformer radio detector, AX1010 noise suppression IC and TCA4500A advanced stereo decoder IC. Only needs front end to make FM tuner or car radio. Complete with circuit. Incredible value at Only £1.99

LINSLEY HOOD 300 SERIES AMPLIFIER KITS

Ultra high quality, Mosfet output. Hi Fi amplifier kits by this famous designer. Two models of identical appearance are available, one giving 35 watts per channel output, the other 45. Careful design has made these amplifiers capable of superb sound quality. The delicacy and transparency of the tone quality enables them to outperform, on a side by side comparison, the majority of commercial amplifiers available today. Building is very easy as almost all components are fitted on easily removed printed circuit boards. Subsequent setting up needs only a simple multimeter to obtain the full specified performance. Both kits come with very comprehensive building instructions. £98.79
K300 35 35 Watt Complete Kit £102.36
K300 45 45 Watt Complete Kit £1.05 no vat
Reprints of Original Articles.

LINSLEY-HOOD CASSETTE RECORDER CIRCUITS

Complete record and replay circuits for very high quality low noise stereo cassette recorder. Circuits are optimised for our HS16 Super Quality Sendust Alloy Head. Switched bias and equalisation to cater for chrome and ferric tapes. Very easy to assemble on plug-in PCBs. Complete with full instructions. £33.70
Complete Stereo Record/Play Kit £2.30 each
VU Meters to suit 75p. no vat
Reprints of original Articles.

STUART TAPE RECORDER CIRCUITS

Complete stereo record, replay and bias system for reel to reel recorders. These circuits will give studio quality with a good tape deck. Separate sections for record and replay give optimum performance and allow a third head monitoring system to be used where the deck has this fitted. Standard 250mV input and output levels. Full details are in our lists. £1.30 no vat
Reprint of Original Articles.

HIGH QUALITY REPLACEMENT CASSETTE HEADS



Do your tapes lack treble? A worn head could be the problem. Fitting one of our replacement heads could restore performance better than new! Standard mountings make fitting easy and our TC1 Test Cassette helps you set the azimuth spot on. We are the actual importers which means you get the benefit of lower prices for prime parts. Compare us with other suppliers and see! The following is a list of our most popular heads, all are suitable for use on Dolby machines and are ex-stock.

- HC20 Permalloy Stereo Head. This is the standard head fitted as original equipment on most decks £7.66
- HS16 Sendust Alloy Super Head. The best head we can find. Longer life than Permalloy, higher output than Ferrite, fantastic frequency response £14.86
- HQ551 4-Track Head for auto-reverse or quadrophonic use. Full specification record and playback head £14.60
- SM166 Standard Mounting 2/2 Erase head. Compatible with above or HQ551 4 Track head £5.90
- HS24 Standard Erase Head. Semi double gap, high efficiency £2.25
- HS61 Metal Tape Erase Head. Full double gap £7.35
- HX100 Special Offer Stereo R/P Heads £2.49
- HRP373 Sendust Alloy Stereo Combination Head £38.80
- HRP373 Technical specification 15p
- HS9510 2/4 Stereo DC Erase Head £6.70
- HQ751E 4/4 Erase compatible with HQ551 £39.70

HART TRIPLE-PURPOSE CASSETTE TC1

One inexpensive test cassette enables you to set up VU level, head azimuth and tape speed. Invaluable when fitting new heads. Only £4.66 plus VAT and 50p postage.

Tape Head De-magnetiser. Handy size mains operated unit prevents build up of residual head magnetisation causing noise on playback £4.54
Curved Pole Type for inaccessible head £4.85

send for your free copy of our LISTS. Overseas please send 2 IRCs to cover surface Post or 3 IRCs for Airmail. Please add part cost of post, packing and insurance as follows:

- INLAND Orders up to £10 50p
- Orders £10 to £49 £1.00
- Orders over £49 £1.50
- OVERSEAS Please send sufficient to cover Surface or Air Post as required.

Personal callers are always very welcome but please note that we are closed all day Saturday

24 Hour Sales Line PLEASE ADD VAT TO ALL PRICES
(0691) 652894



BI-PAK BARGAINS

Pak No	Qty	Description	Price
RESISTORS			
VP1	300	Assorted Resistors, mixed values and types	£1.00
VP2	300	Carbon Resistors 1/4-watt, pre-formed, mixed	£1.00
VP3	200	1/4 watt Min. Carbon Resistors, mixed values	£1.00
VP4	200	1/2 watt Min. Carbon Resistors, mixed values and types	£1.00
VP5	50	Wirewound Resistors, mixed watt values	£1.00
VP11	1	Sub Resistance Box. 36 values 50ohms-1Kohms	£4.75
VP140	50	Precision Resistors, 1% tolerance	£1.00
VP181	100	1 and 2 watt Resistors, assorted values	£1.00
CAPACITORS			
VP5	200	Assorted Capacitors, all types	£1.00
VP6	200	Ceramic Capacitors, Min. mixed values	£1.00
VP8	100	Mixed Ceramic Disc. 50pF-0.05µF	£1.00
VP9	100	Assorted Polyester/Polystyrene Capacitors	£1.00
VP10	60	C280 Capacitors. Metal foil, mixed values	£1.00
VP11	50	Electrolytics, all sorts	£1.00
VP12	40	Electrolytics, 47µF-150µF, mixed volts	£1.00
VP13	30	Electrolytics, 150µF-1000µF, mixed volts	£1.00
VP15	25	0.125vdc Min. Layer Metal Caps	£1.00
VP16	25	50kΩ Tantulum Caps. mixed values	£1.00
VP180	25	Tantulum Bead Caps, assorted values	£1.00
VP182	4	1000µF 50v Electrolytics	£1.00
VP182	30	Min. Electrolytics, mixed values, 47µF-1000µF 6/16v	£1.00
VP193	1	5 Sub Min. Electrolytics, 2 x 1000/2200/3300µF 10/16v	£1.00
OPTOS			
VP24	10	125x Clear showing Red LEDs	£1.00
VP25	10	Mixed shape and colours LEDs	£1.00
VP26	15	Small 125x Red LEDs	£1.00
VP27	15	Large 2x Red LEDs	£1.00
VP28	10	Rectangular 2x Red LEDs	£1.00
VP29	25	Opto special pack. Assorted. Super Value	£5.90
VP130	6	RED 7 Seg. OC 14mm x 75mm RDP FND253 LED Display	£2.00
VP131	4	GREEN 7 Seg. CA 8 LDP XAN6250 LED Display	£2.00
VP132	5	RED 7 Seg. CC 8 LDP XAN8940 LED Display	£2.00
VP133	6	RED Overflow 8 3/4 x CA CC 863650 LED Display	£2.00
VP134	5	GREEN Overflow 8 CA XAN6350 LED Display	£2.00
VP137	3	DUAL RED 7 Seg. 51 CA DDP LED Display	£2.00
VP138	20	Assorted LED Displays. Our mix, with data	£5.00
VP147	1	Pair Opto Coupled Modules	£1.00
VP199	4	D17075 LED Display CA	£1.00
VP203	15	Triangular shape LEDs. Mixed colours	£1.00
VP204	10	Large Green LEDs, 5mm	£1.00
VP205	10	Small Green LEDs, 3mm	£1.00
VP206	10	Large Yellow LEDs, 5mm	£1.00
VP207	10	Small Yellow LEDs, 3mm	£1.00
VP208	10	Large LEDs Clear showing Red. Z'	£1.00
DIODES & SCRS			
VP29	30	Assorted volts Zeners 50mw-2w	£1.00
VP30	10	Assorted volts Zeners 10w, coded	£1.00
VP31	10	5A SCRs 1066, 50-400v, coded	£1.00
VP32	20	3A SCRs 1066, up to 400v, uncoded	£1.00
VP33	200	Sil. Diodes like IN4148	£1.00

Pak No	Qty	Description	Price
VP34	200	Sil. Diodes like OA20/BA13-16	£1.00
VP35	50	1A IN4000 Diodes, all good, uncoded	£1.00
VP39	30	Assorted Sil. Rectifiers, 1A-10A, mixed volts	£1.00
VP40	40	BA402 Sil. Rectifiers, 1A 100v, preformed pitch	£1.00
VP42	4	40A Power Rectifiers, Silicon, T048 300 PIV	£1.00
VP43	5	BY127 12KV Sil. Diodes in carriers, 2.5MA	£1.00
VP184	4	4A 400v Triacs, plastic	£1.00
VP187	10	SCRs 400MA 250V 2N6054, plastic, T092	£1.00
VP194	50	OA91 point contact Germ. Diodes, uncoded	£1.00
VP195	50	OA47 gold bonded Germ. Diodes, uncoded	£1.00
VP196	50	DA70-79 detector Diodes, Germ.	£1.00
VP197	10	OA80 type Germ. Diodes, uncoded	£1.00
VP198	40	BA248 Sil. Diodes, 350V 2A, fast recovery	£1.00
VP22	20	3A Stud Rectifiers, 50-400v	£1.00
TRANSISTORS			
VP38	100	Sil. Transistors, NPN plastic, coded, with data	£3.00
VP39	100	Sil. Transistors, PNP plastic, coded, with data	£3.00
VP45	50	BC107/8 NPN Transistors, good, uncoded	£1.00
VP46	50	BC177/8 PNP Transistors, good, uncoded	£1.00
VP47	10	Sil. Power Transistors, similar 2N3055, uncoded	£1.00
VP48	4	Pair NPN/PNP plastic Power Transistors, 4A, data	£1.00
VP50	60	NPN Sil. Switching Transistors, TO-18 and TO-92	£1.00
VP51	60	PNP Sil. Switching Transistors, TO-18 and TO-92	£1.00
VP60	100	All sorts Transistors, NPN/PNP	£1.00
VP187	15	2TX300 series Sil. Transistors, PNP plastic	£1.00
VP158	15	2TX107 Sil. Transistors, NPN eqvt. BC107 plastic	£1.00
VP159	15	2TX108 Sil. Transistors, NPN eqvt. BC108 plastic	£1.00
VP161	25	BC183L Sil. Transistors, NPN 30v 200mA T092	£1.00
VP162	5	SJES451 Sil. Power Trans. NPN 80V 1A HF5024	£1.00
VP163	2	NPN/PNP pairs Sil. Power Trans. like SJES451	£1.00
VP164	4	2N6289 Sil. Power Trans. NPN 40v 40w 7A HF3030	£1.00
VP170	10	Assorted Power Transistors, NPN/PNP coded and data	£1.00
VP171	10	8B255 NPN TO-39 Sil. Trans. eqvt. BF258 225v 100mA	£1.00
VP172	10	SM1502 PNP TO-39 Sil. Trans. 100v 100mA HF100+	£1.00
VP200	30	OC71 type Germ. AF Transistors, uncoded	£1.00
VP201	25	OC45 Germ. RF Transistors	£1.00
VP202	15	BFY51 type Sil. 2A Transistors, BF734	£1.00
I.C.s			
VP40	40	TTL I.C.s all new gates - Flip Flop - MSI, Data	£4.00
VP41	40	CMOS I.C.s all new. Data	£4.00
VP55	10	I.C.s 4118 Memories	£2.00
VP59	20	Assorted I.C.s linear, etc., all coded	£2.00
VP209	12	74LS200	£2.00
VP210	12	74LS274	£2.00
VP211	10	CD4001B	£2.00
VP212	10	CD4011B	£2.00
VP214	10	CD4069B	£2.00
VP215	10	7418 8 pin	£1.50
VP216	10	555 Timers 8 pin	£1.50
TOOLS			
VP102	1	13 pc Tool Set, Screwdrivers, pliers, cutters, etc	£7.50
VP103	1	6 pc STANLEY Screwdriver Set Flat & Crosspoint	£2.50
VP104	1	1 Ratchet Screwdriver Set, 4 blades. Real value.	£1.75
VP139	1	Pick-up Tool, spring loaded	£1.75

Pak No	Qty	Description	Price
VP217	1	Helping Hand	£4.00
VP218	1	Watchmakers Screwdriver Set, 6 pieces	£1.75
VP219	1	Miniature Soldering Iron	£1.55
VP220	1	Miniature Bent-nose Pliers	£1.55
VP221	1	Miniature Long-nose Pliers	£1.55
74 SERIES SALE "ROCK BOTTOM" PRICES			
VP223	50	Asst TTL I.C.s. "ALL GATES" new & coded our mix 7400-7453	£8.00
VP224	100	Asst TTL I.C.s. "ALL GATES" new & coded our mix 7400-7453	£10.00
VP7413	4	7413 Dual 4-Input NAND Schmitt Trigger, 4-Input	£1.00
VP7440	4	7440 Dual 4-Input Positive-Nand Buffer	£1.00
VP7470	4	7470 And-gated Flip-Flop with preset	£1.00
VP7480	4	7480 Gated full Adder	£1.00
VP7481	4	7481 16-Bit Random Access memories	£1.00
VP7490	4	7490 Decade Counter	£1.00
VP7491	4	7491 8-Bit Shift Register	£1.00
VP7492	4	7492 Divided by 12 Counter	£1.00
VP7493	4	7493 4-Bit Binary Counter	£1.00
VP7494	4	7494 4-Bit Shift Register	£1.00
VP7495	4	7495 4-Bit Shift Register	£1.00
VP7411	4	7411 Dual J-K Master Slave Flip-Flop	£1.00
VP7414	4	7414 BCD - Decimal Decoder/Driver	£1.00
VP7451	4	7451 1 of 8 Data Selectors/Multiplexers	£1.00
VP7453	4	7453 Dual 2 to 1 Line Data Selectors/Multiplexers	£1.00
VP7416	4	7416 8-Bit Parallel Output Serial Shift Registers	£1.00
VP7467	4	7467 Synchronous Decade Rate Multipliers	£1.00
BP7474	4	7474 Hex D-Type Flip-Flops	£1.00
VP7418	4	7418 Arithmetic Logic Units/Function Generators	£1.00
VP7413	4	7413 Synchronous Up/Down Dual Counters	£1.00
VP7493	4	7493 Binary clear	£1.00
VP7429	4	7429 Quad S-R Latches	£1.00
BPX6 1 TTL Data Book 74 Series, including "LS". Complete with Pin out Diagrams, 7400-7470. TTL Interchangeability Guide Function Selection Guide and Explanation of Function Tables.			
BPX5 1 IC555 Projects Book (Timer) 167 pages over 50 Project Circuits to build and other information on 5555 Timers. Plus FREE with our compliments, 4 x I.C.s 555 Timers, worth £120. Special offer price just £2.95			
BPX3 3 Computer Books on Programming Micro Processors and ZX81, etc. Special offer price just £2.50			
BPX1 4 Different Popular Books on Electronic Projects. Hours of interesting reading and construction. Special offer price just £8.00			
8B1 Half Price Book Bundle Offer. Hundreds of books on Electronic Projects, Computers, Integrated Circuits, Audio, Radio, etc. For too many to mention. 5 books list value approx. £10-£11. This Book Bundle is different so buy 2 or 3 and not repeat. Money refunded if not completely satisfied. Special offer price just £5.00			

Send your orders to Dept. EK, BI-PAK PO BOX 6 WARE, HERTS TERMS CASH WITH ORDER, SAME DAY DESPATCH. ACCESS. BARCLAYCARD ALSO ACCEPTED. TEL 0763-48851. GIRO 388 7006. ADD 15% VAT AND £1.50 PER ORDER POSTAGE AND PACKING



Use your credit card. Ring us on 0763-48851 NOW and get your order even faster. Goods normally sent 2nd Class Mail. Remember you must add VAT at 15% to your order. Total Postage add £1.00 per Total order.

HI-FIDELITY WITH SOUND PRINCIPLES



Complete Hi-Fi kit for less than £140

- ★ 40 watts RMS per channel into 8 Ω, 80 watts into 4 Ω
- ★ High current output, stabilised PSU for power amps
- ★ Minimum capacitor passive equalisation design
- ★ MM/MC with infra cut, CD, Rad, Tape 1 & 2 inputs
- ★ Rugged TO3 complementary output & PSU transistors
- ★ Comprehensive instructions, quality components

Much is said about amplifier design. Specification and technical performance alone no longer rules supreme. Concepts such as musicality are regarded as sacred by the Hi-Fi fraternity. The state of the art is for amplifiers to have high output current capability, high overload margins be "neutral sounding yet articulate and dynamic". High feedback designs are definitely out, capacitors and cables affect the sound.

Where does the engineer stand in all this? We think you would like an amplifier with real state of the art features but not over the top in insignificant design detail. You are unhappy at paying for a mass produced product. You appreciate a top class system but cannot justify the price of more exotic products. Building your own to an exclusive and well engineered design has a definite attraction.

GATE ONE utilises the latest audiophile techniques in its design. Great attention is given to the layout with separate signal and component earths. RIAA equalisation and tone controls (with in/out switch) are of a passive design. A low lift switch lets you tailor response to compensate for loudspeaker deficiency. A unique volume control circuit increases overload margin and optimises S/N ratio. All power transistors including the fully regulated PSU are TO3 Type with large chip area to minimise distortion due to thermal effects.

You can buy a GATE ONE in kit form for £139.61 inc. or a GATE MONITOR ONE stereo power amp with 3 line inputs for £114.85 inc. Both have a professionally finished case and include all components. Both are available fully assembled and tested. Order now or send for further comprehensive details.

GATEHOUSE AUDIO (PE)

PO Box 6, Evesham, Worcs. WR11 4NP.

Money back
guarantee if kit
returned unused.

CRICKLEWOOD ELECTRONICS LTD



It's no secret...

...that there is a real difference at Cricklewood Electronics. That's why you should never be without the FREE CRICKLEWOOD ELECTRONICS COMPONENTS CATALOGUE, for sheer variety, competitive prices and service from the U.K.'s number one 100% component shop. No gimmicks, no gadgets or computers, just components, millions of them, all easily available by mail order, calling or credit card telephone orders. Just pick up the phone (or a pen) to get your FREE copy now (no SAE required). You have nothing to lose.

CRICKLEWOOD ELECTRONICS LIMITED

40 Cricklewood Broadway, London NW2 3ET

Tel: 01-450 0995/01-452 0161

Telex: 91 4977



PE

C.M. HOWES COMMUNICATIONS

139, Highview, Vigo,
Meopham, Kent,
DA13 0UT England.

Fairseat(0732)823129

Hello Practical Electronics!

C.M. HOWES COMMUNICATIONS is a specialist manufacturer of radio communications kits and modules, with the emphasis on simple, effective, amateur ("ham") radio equipment. We have been selling kits for over four years now, but this is our first advert in a more general interest electronics magazine. We wonder if our kits could tempt some readers into the exciting world of shortwave radio?

I am sure there must be a lot of home computers out there looking for something interesting to do! One of our DcRx Communications Receivers would not only enable you to listen to radio hams talking World-wide, but with a suitable interface, home computer and software, to read radio teleprinter, facsimile, and morse code signals too. The HOWES DcRx receiver kit is available in several versions for various amateur bands. The 20M band is the most popular for long distance communication, whilst the 80M band is very popular for UK communication during daylight hours, and longer distances at night. This band is also shared with the marine services. The DcRx kit costs £15.30, and £20.90 as an assembled module. A case and a couple of tuning capacitors are the only major parts you need to add. We have suitable tuning capacitors at £1.50 each. P&P is 90p. Why not send an SAE for more information?

All our kits are to build PCB modules, and contain a PCB, and all board mounted components, plus full instructions. You will be amazed what you can hear on one of our super little receivers! We also have companion transmitters available for licenced amateurs. These start at £13.40, so you don't have to be rich to take up the hobby!

We also stock kits for filters, speech processors, shortwave broadcast receivers, oscillators, amplifiers, transverters, antenna tuners etc. The catalogue is free, simply drop us a line enclosing an SAE, and mention Practical Electronics. We can also send an information sheet on any product you are particularly interested in.

"73" (best wishes) from Dave G4KQH, Technical Manager.

EASY TO BUILD KITS BY MAIL ORDER



INDUSTRY NOTEBOOK

REPORT BY TOM IVALL – PE's NEXUS

Human motivations in the industry

Reasons for being involved in a business can vary widely, but the higher up the corporate tree they go, the more essential it is that individuals keep in close touch with the interests of the industry.



LET US continue our discussion, I started last month, on the interaction of the electronics industry with society at large – and hence with the lives of individuals like you and me.

To do this we must first look inside the industry itself, to see what sort of animal it is. Although I've been talking about the industry as if it were a clear entity, it is in fact rather amorphous. It holds together in a very loose kind of way. For example, the commonality of technology is really just a concept, a categorisation made by the observer. And things like the trade deficit which the British electronics industry has with the rest of the world are similarly just statistics, the result of analysis by economists and businessmen.

Certainly there is some degree of mutual dependence. An equipment maker depends on reliable supplies of particular components from firms specialising in these products. Equally the component manufacturers rely on the equipment makers to provide them with custom and therefore income. If the supply of a particular type of i.c. dries up, it can be anything from inconvenient to disastrous for the equipment firm. But in practice the company switches its custom to another component supplier, and there is not much sentiment or loyalty affecting the issue. Such patterns of mutual dependence and shared interests are reflected in the existence of trade associations like Electronic Engineering Association in the UK.

But when you get down to the level of the individual companies forming the industry, the picture changes. Here the motivations of humans are powerful and crucial. For example, anyone who starts up a new firm, perhaps with partners, must be highly motivated to do it at all. One doesn't just drift into such an undertaking. Equally, in a small group of people, say a development team within a large company, the presence or absence of certain individuals, the knowledge, experience and performance of these persons, can be crucial to the task in hand. Companies

talk about 'key personnel' and this is what they mean.

So what are the motivations of employees in companies? If you walk into an electronics firm from the outside world you immediately get a snapshot of people working away on their own or in small groups and apparently independently. There is no obvious sign of general compulsion, like a slave driver with a whip, but they are all occupied and immersed in their separate tasks. Even the slackers, intent on getting through the day with as little expenditure of effort as possible, will be putting a good deal of ingenuity into the task of appearing to work, or deluding themselves that they are doing something productive.

There is an old saw that if you ask three workers on the same production line what they are actually doing, one will say "I'm making a living", the second will say (for example) "I'm assembling these components on this printed-circuit board" and the third will say (for example) "I'm helping to build a process control computer that will improve the efficiency of an ICI chemical plant." This is grossly oversimplified, of course, but it does illustrate the fact that individuals can have different views of the same work and different reasons for doing it.

Obviously most of us have to make a living. This is a general requirement. But we all know people for whom job satisfaction is more important than the amount of the salary. For others the primary consideration is that their job enables them to live in a certain area. Professionals often see their present job as a stepping-stone in a planned career. Some people, who might otherwise be lonely, rate the companionship offered by work more highly than the money attached. And, of course, with the present high level of unemployment, many are glad to get any kind of job at all and they work simply to keep it.

In a good firm all these different drives and interests work together harmoniously, though some conflicts and forced compromises may be

inevitable. When this happens it is a sign of good management.

The further you go up the hierarchy of a company the more important become the business imperatives. The production director or the sales director of an electronics company may be preoccupied with problems and targets in these particular areas, but they also have wider responsibilities to their fellow directors, to the profit and loss account, to the shareholders, and to the survival of the company as a whole in a competitive environment.

At this level of higher management the traditional view is that there is one predominant objective: to maximise profits. This is certainly true for small companies where the few individuals forming the management are also the owners of the firm: they have a lot to gain or lose. But the larger the company the more it tends to separate the functions of control and ownership. The firm is controlled by employed managers and owned by shareholders.

Generally speaking the shareholders, who might be pension funds or other financial institutions, do not get involved in management as long as their dividends are satisfactory and the market values of their holdings are maintained. Equally, the managers do not have any direct concern or responsibility for the capital invested and its returns. Consequently they are not primarily motivated to maximise profits to keep up share prices and dividends on the stock market.

So in these circumstances of divorce between control and ownership the senior managers tend to be motivated by other things that give them satisfaction. It could be a higher salary, enjoyment of greater power or status, a larger office or company car, something in the Honours List, more free time for golf, or any of a wide range of perks. This situation can be dangerous if the managers spend too much time and effort chasing things which are not essential to the business success of the company. Then the shareholders might have to intervene.

PE

SAXON MOSFET AMPLIFIERS

UNBEATABLE PRICES!!!

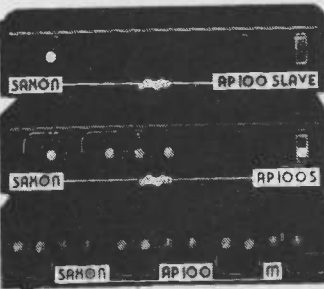

SLAVE MODEL
 AP 100 100W RMS £69
 AP 200 200W RMS £89

2 INPUT GENERAL PURPOSE MODEL
 AP 100S £79
 AP 200S £99

P.A. MODEL
 ★ 6 INPUTS
 ★ 3 CHANNELS
 ★ ECHO IN/OUT

★ TREBLE/BASS EACH CHANNEL ★ INDIVIDUAL VOLUMES
 ★ MASTER PRESENCE

Write or phone for a **FREE BROCHURE** on these incredible amplifiers
 AP 100M **£99**
 AP 200M **£119**

P.E. HYPERCHASER

£84.95



4 CHANNEL PSEUDO INTELLIGENT LIGHT UNIT
 ★ 16 Programmes
 ★ Manual Flash Buttons
 ★ Manual/Auto Programme
 ★ Strobe Duplets
 ★ Individual Dimming
 ★ Sound To Light

Not just a light unit but a sophisticated & comprehensive effects unit. A full kit of parts including P.C.B., Facia, Case, etc. Reprint of article on request.

P.E. STAR DESK

£209



8 + 4 CHANNEL LIGHT MIXING DESK
 ★ 8 Channel Twin Preset Mixer
 ★ Strobe Outputs
 ★ 4 Independent Channels
 ★ 4/8 Channel Sequences
 ★ 8 Programmes
 ★ Manual Flash Buttons
 ★ 1KW Output/Channel (can be boosted to 2KW/Ch)
 ★ Timed Crossfade
 ★ Soft/Hard Sequence

A truly magnificent unit ideal for clubs, groups, drama, etc. A full kit of parts inc. PCB, Facia, Case, etc. Reprint of article on request.

CRYDON DISCO CENTRE

327 Whitehorse Road, Croydon, Surrey CR0 2HS
 (01) 684 8007 9am-5pm. Mon-Sat. (Closed Wed.)



Post & Packing £4 per item. Please allow 14 days for delivery

CMOS	4089	80p	74LS55	17p	74LS257	42p	280HCTC 600p	LM301	28p
4000	13p	4093	18p	74LS73	28p	74LS258	52p	280AS10 600p	AN-214P
4001	13p	4095	56p	74LS74	22p	74LS259	52p	280AS10 1700p	AN-240P
4002	13p	4098	56p	74LS76	28p	74LS260	38p	280AS10 700p	AN-380
4005	36p	4099	45p	74LS78	28p	74LS262	28p	280ADART 600p	AN-710
4006	36p	4099	45p	74LS78	28p	74LS273	52p	AN-7114	180p
4007	13p	4501	30p	74LS83	43p	74LS279	40p	AN-7115	180p
4008	20p	4502	35p	74LS86	45p	74LS280	140p	AN-7120	140p
4009	20p	4503	35p	74LS86	45p	74LS290	30p	AV3-1270	800p
4010	21p	4504	55p	74LS90	32p	74LS293	30p	AV3-1350	300p
4011	13p	4505	200p	74LS91	75p	74LS365	37p	AV3-8919	370p
4012	13p	4506	200p	74LS92	38p	74LS366	37p	AV3-8912	370p
4013	19p	4508	70p	74LS93	30p	74LS367	74p	AV5-3600	580p
4014	35p	4510	37p	74LS95	47p	74LS368	38p	CA270	40p
4016	18p	4511	40p	74LS107	32p	74LS373	55p	CA3040	10p
4017	31p	4512	42p	74LS109	34p	74LS375	58p	CA3048	10p
4018	33p	4514	75p	74LS112	36p	74LS375	58p	CA3060	280p
4019	28p	4515	75p	74LS113	32p	74LS399	80p	CA3080E	70p
4020	35p	4516	40p	74LS114	35p	74LS670	72p	CA3088	55p
4021	36p	4517	120p	74LS122	40p	7413	35p	CA3090A	150p
4022	36p	4518	38p	74LS123	42p	7413	35p	CA3130E	80p
4023	13p	4519	30p	74LS124	85p	7413	35p	CA3130S	100p
4024	25p	4520	30p	74LS125	36p	27256	400p	CA3140E	35p
4025	13p	4521	80p	74LS126	36p	2532	330p	CA3189E	250p
4026	60p	4522	80p	74LS132	40p	2716	200p	CA3240E	90p
4027	18p	4526	40p	74LS133	34p	2732	280p	HA-1159W	110p
4028	29p	4527	44p	74LS136	35p	2764	240p	HA-1305W	170p
4029	35p	4528	40p	74LS138	35p	2778	250p	HA-1319	250p
4030	17p	4529	75p	74LS139	35p	4118	75p	HA-1339	170p
4031	30p	4532	52p	74LS145	83p	4184	110p	HA-1347	170p
4032	54p	4533	52p	74LS147	83p	6116	160p	HA-1368WR	100p
4033	60p	4533	190p	74LS148	90p	6284-15	250p	LA-1368	160p
4034	80p	4555	29p	74LS151	32p	6809	600p	LA-1377	220p
4035	85p	4556	38p	74LS153	40p	6802	220p	LA-1389	230p
4036	180p	4557	190p	74LS156	47p	6809	600p	LA-1392	230p
4038	48p	4584	30p	74LS155	41p	6809	600p	LA-1397	250p
4039	190p	4585	42p	74LS157	30p	6840	310p	LA-1398	240p
4040	36p			74LS158	33p	6850	110p	LA-1400	200p
4041	38p			74LS158	33p	6850	110p	LA-1405	130p
4042	30p			74LS160	48p	8080A	400p	LA-4051	80p
4043	36p			74LS181	50p	8085A	320p	LA-4100	30p
4044	38p			74LS180	50p	8155	380p	LA-4111	52p
4045	72p			74LS182	48p	8155	380p	LA-4125K	85p
4046	45p			74LS183	45p	8156	360p	LA-4125	85p
4047	45p			74LS183	45p	8224	270p	LA-4140	70p
4048	27p			74LS186	74p	8228	270p	LA-4201	120p
4049	18p			74LS188	74p	8228	270p	LA-4220	120p
4050	20p			74LS189	65p	8243	250p	LA-4400	180p
4051	38p			74LS199	55p	8250	850p	LA-4420	140p
4052	30p			74LS199	55p	8251	300p	LA-4422	130p
4053	37p			74LS175	42p	8253	340p	LA-4430	130p
4054	53p			74LS190	55p	8255	360p	LA-4480	180p
4055	52p			74LS191	52p	8256A	1200p	LA-4481	180p
4056	52p			74LS192	50p	8257A	370p	LA-5112	120p
4057	40p			74LS193	51p	8257A	370p	DA1170	100p
4058	52p			74LS194	53p	8259	370p	DA1171	100p
4059	20p			74LS202	15p	8259	440p	DA1172	100p
4060	130p			74LS242	38p	8272	1300p	DA1173	100p
4061	13p			74LS221	55p	8279	850p	DA1174	70p
4062	13p			74LS226	16p	8282	400p	DA1175	50p
4063	13p			74LS227	15p	8283	400p	DA1176	50p
4064	13p			74LS231	15p	8284	500p	DA1177	50p
4065	13p			74LS232	17p	8288	1000p	DA1178	50p
4066	13p			74LS243	80p	8748	2900p	DA1179	50p
4067	13p			74LS247	50p	8748	2900p	DA1180	50p
4068	13p			74LS248	50p	8748	2900p	DA1181	50p
4069	13p			74LS249	50p	8748	2900p	DA1182	50p
4070	13p			74LS251	50p	8748	2900p	DA1183	50p
4071	13p			74LS252	50p	8748	2900p	DA1184	50p
4072	13p			74LS253	50p	8748	2900p	DA1185	50p
4073	13p			74LS254	50p	8748	2900p	DA1186	50p
4074	13p			74LS255	50p	8748	2900p	DA1187	50p
4075	13p			74LS256	60p	8748	2900p	DA1188	50p
4076	13p			74LS257	60p	8748	2900p	DA1189	50p
4077	13p			74LS258	60p	8748	2900p	DA1190	50p
4078	13p			74LS259	60p	8748	2900p	DA1191	50p
4079	13p			74LS260	60p	8748	2900p	DA1192	50p
4080	13p			74LS261	60p	8748	2900p	DA1193	50p
4081	13p			74LS262	60p	8748	2900p	DA1194	50p
4082	13p			74LS263	60p	8748	2900p	DA1195	50p
4083	13p			74LS264	60p	8748	2900p	DA1196	50p
4084	13p			74LS265	60p	8748	2900p	DA1197	50p
4085	13p			74LS266	60p	8748	2900p	DA1198	50p
4086	13p			74LS267	60p	8748	2900p	DA1199	50p
4087	13p			74LS268	60p	8748	2900p	DA1200	50p
4088	13p			74LS269	60p	8748	2900p	DA1201	50p
4089	13p			74LS270	60p	8748	2900p	DA1202	50p
4090	13p			74LS271	60p	8748	2900p	DA1203	50p
4091	13p			74LS272	60p	8748	2900p	DA1204	50p
4092	13p			74LS273	60p	8748	2900p	DA1205	50p
4093	13p			74LS274	60p	8748	2900p	DA1206	50p
4094	13p			74LS275	60p	8748	2900p	DA1207	50p
4095	13p			74LS276	60p	8748	2900p	DA1208	50p
4096	13p			74LS277	60p	8748	2900p	DA1209	50p
4097	13p			74LS278	60p	8748	2900p	DA1210	50p
4098	13p			74LS279	60p	8748	2900p	DA1211	50p
4099	13p			74LS280	60p	8748	2900p	DA1212	50p
4100	13p			74LS281	60p	8748	2900p	DA1213	50p
4101	13p			74LS282	60p	8748	2900p	DA1214	50p
4102	13p			74LS283	60p	8748	2900p	DA1215	50p
4103	13p			74LS284	60p	8748	2900p	DA1216	50p
4104	13p			74LS285	60p	8748	2900p	DA1217	50p
4105	13p			74LS286	60p	8748	2900p	DA1218	50p
4106	13p			74LS287	60p	8748	2900p	DA1219	50p
4107	13p			74LS288	60p	8748	2900p	DA1220	50p
4108	13p			74LS289	60p	8748	2900p	DA1221	50p
4109	13p			74LS290	60p	8748	2900p		

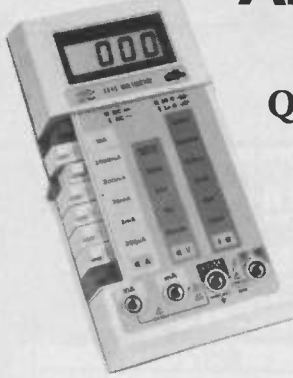

AFFORDABLE ACCURACY

Quality Multimeters from Cirkit

A comprehensive range of Analogue and (Pushbutton or Rotary Switched) Digital Models

ANALOGUE

HM102BZ - 20kΩ/V DC. DC voltage range; 2.5-1000V, AC volts 10-1000V; resistance 10k-1MΩ DC current 5-500mA + 10A, battery and continuity test **£12.50**
HM-1015 - Rugged, Pocket sized meter, for general purpose use 16 measuring ranges **£7.50**

Battery, Test Leads and Manual included with each model.

Please add 15% for VAT and 70p for P&P

Full details and specification from:

DIGITAL

HC-7030
0.1% Accuracy. Standard Model **£39.50**
HC-6010 (illustrated above)
0.25% Accuracy. Standard Model **£33.50**
HC-5010T
0.25% Accuracy. TR Test Facility **£39.50**
DM-105
0.5% Accuracy. Pocketable **£21.50**

All models have full functions and ranges and feature 3 1/2 digit 0.5" LCD display - low battery indication - auto zero & auto polarity - ABS plastic casing - DC/AC 10amp range (not DM-105) - Overload protection on all ranges - battery, spare fuse, test leads and manual.

Cirkit Distribution Ltd

Park Lane, Broxbourne, Herts EN10 7NQ
Telephone (0992) 444111 Telex: 22478

TRADE ENQUIRIES WELCOME



OSCILLOSCOPES

TELEQUIPMENT D75. Dual Trace 50MHz. Delay Sweep. With Manual **£325**
 COSSOR CDU150. Dual Trace 35MHz. Solid State. Portable 8 x 10 cm display with manual **£200**
 TELEQUIPMENT D61. Dual Trace 10MHz. With Manual **£150**
 TELEQUIPMENT D43. Dual Trace 15MHz. With Manual **£100**
 SOLARTRON CD1400. Dual Trace 15MHz. With Manual **£100**
 TELEQUIPMENT S54A. Single Trace 10MHz. Solid State. With Manual **£110**

COMMUNICATION RECEIVERS

RACAL RA17L. 500KHz-30 MHz. With Manual. only **£140** each
 EDDYSTONE 730/4. 480KHz-30MHz. With Manual. only **£110** each

MULTIMETERS

AVO 9 Mk4 (identical to Avo8 Mk4 but scaled differently). Complete with Batteries & Leads. **£55**
 AVO 8 Mk2. Complete with Batteries & Leads. **£45**
 Above items in GOOD WORKING ORDER - appearance not A1 hence the price.
 AVO TEST SET No 1 (Military version of AVO 8) Complete with Batteries, Leads & Carrying Case **£65**
 AVO Model 7X. Complete with Batteries, Leads & Carrying Case **£40**
 ANALOGUE POCKET MULTIMETERS. PHILIPS/TAYLOR/AVO etc. Complete with Batteries & Leads from **£10**

STEPPING MOTORS

TYPE 1. 200 Steps per rev. 4 Phase (5 wire). 12/24V. Torque 25oz inch/will run on 5V with reduced torque) **£5** each
 TYPE 2. 6/12 Steps per rev. 3 Phase. 12/24V (will work on 5V) **£2** each
 5 off **£7.50**
 TYPE 3. NORTH AMERICAN PHILIPS. 24 Steps per rev. 4 wire 5V 3.3Amps 0-250 rpm 0-200 PPs **£6** each
 TYPE 4. 200 Steps per rev. 120V (3 wire) Torque 25 oz inch **£4** each
 TYPE 7. WARNER 24 Steps per rev. 3 Phase (6 wire). 28V. Holding Torque 45 oz inch. **£5** each

Used equipment - with 30 days guarantee. Manuals supplied if possible.
 This is a VERY SMALL SAMPLE OF STOCK. SAE or Telephone for Lists. Please check availability before ordering. CARRIAGE all units £16. VAT to be added to Total of Goods & Carriage.
 Callers welcome 9 a.m. to 5.30 p.m. Mon-Fri (until 8 p.m. Thurs)

STEWART OF READING

110 WYKEHAM ROAD, READING, BERKS RG6 1PL
Telephone: 0734 68041

AVO TRANSISTER TESTER TT169. Handheld GO/NOGO for In-situ Testing. Complete with Batteries, leads & instructions (P&P £3) now only **£12**

DISK DRIVE PSU. 240V 1N; 5V 1.6A & 12V 1.5A out. Size: W125mm. H75mm. D180mm. Cased Un-used. (P&P £2) only **£10**
 QWERTY KEYBOARD. Cased. ASCII Coded + Un-coded Keypad & Function Keys. Requires +/- 12V. With Info. Un-used. (P&P £4) **£25**
 QWERTY KEYBOARD (as in LYNX MICRO). Push to make. Cased (P&P £2) only **£5**
 DISK DRIVE 5 1/4" full height. 80 track double sided. Double density. With Manual. Used (P&P £5) **£45** each

SPECIAL OFFERS

B + K Precision CRT Restorer/Analyser Model 467. Supplied with 2 bases and Manual (P&P £7) only **£125** each
 LABGEAR Colour Bar Generator KG1. 8 Test patterns (P&P £4) only **£40** each

RACAL UNIVERSAL COUNTER TIMER Type 836. 32 MHz with Manual only **£50**

ISOLATING TRANSFORMER 240V In - 240V Out. 500VA (P&P £5) **£15** each

NEW EQUIPMENT

HAMEG OSCILLOSCOPE 605. Dual Trace 60MHz. Delay Sweep. Component Tester **£583**
 HAMEG OSCILLOSCOPE 203.6. Dual Trace 20MHz. Component Tester with 2 probes **£314**
 All Other Models Available

BLACK STAR FREQUENCY COUNTERS (P&P £4)
 Meteor 100-100MHz **£99**
 Meteor 600-600MHz **£126**
 Meteor 1000-1GHz **£175**
 BLACK STAR JUPITOR 500 FUNCTION GENERATOR. Sine/Square/Triangle. 0.1Hz 500KHz (P&P £4) **£110**

HUNG CHANG DMM 7030 3 1/2 digit. Hand held 28 ranges including 10 Amp AC/DC 0.1%. Complete with Battery & Leads. (P&P £4) **£39.50**
 AS ABOVE. DMM6010. 0.25% **£33.50**

OSCILLOSCOPES PROBES. Switched x 1; x 10 (P&P £2) **£11**

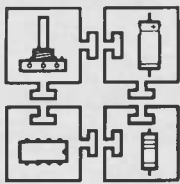

MUSIC, EFFECTS AND COMPUTER KITS

AUDIO A-D-A (PE) SETS 251 £61.00
Audio analogue-to-digital-to-analogue converter with level, gain feedback and feed forward controls. 8-bit parallel data port.

CHIP TESTER (PE) SET 258F £39.30
Computer* controlled logic and chip analyser (up to 24 pins).

CHORUS-FLANGER (PE) SET 235 £59.99
Mono-Stereo. Superb dual-mode effects

CYBERVOX (EE) SET 228 £44.76
Amazing robot type voice unit, with ring-modulator and reverb.

DIGITAL DELAY (PE) SET 198.50.
Upto 65 secs delay, echo, reverb, re-pitch, multi & reverse track, loop, wtc. 64K memory plus micro-interface*. 19 inch rack.

DISCO-LIGHTS (PE) SET 245F £62.50
3 chan sound to light, chasers, auto level. Plus micro interface*.

ECHO-REVERB (PE) SET 218 £57.66
Mono-stereo. 200ms echo (extendable), lengthy reverb switchable multitracking.

MICROSCOPE (PE) SET 247 £44.50
Turns a *Computer into a n oscilloscope.

MICRO-TUNER (PE) SET 257 £55.32
Computer* controlled, very accurate music tuning aid and frequency counter.

MINI-TUNER (EE) SET 259 £22.50
Simple computer* controlled music turning aid.

MIXER (PE) SET 229M £44.45
4 chans, separate gains, levels, filters, twin outputs.

MORSE DECODER (EE) SET 269 £22.16
Computer* controlled morse coder-decoder, with variable rate and level controls.

PHASER (PE) SET 226 £42.36
Excellent phasing enhanced with modulated filtering.

POLYHATSIT! (PE) SET 252 £122.69
Amazing effects unit, echo, reverb, double tracking, phasing, flanging, looping, pitch change, REVERSE tracking! 8K memory.

REVERB (EE) SET 232 £27.35
Mono, with reverb to 4 secs, echo to 60ms.

RING MODULATOR (PE) SET 231 £45.58
Fabulous effects generation, with ALC and ultrawave form VCO.

STORMS! (PE) £29.50 each unit.
Raw nature under panel control! Wind & Rain SET 250W. Thunder & Lightning SET 250T.
 * COMPUTER PROG available for BBC, C64 and PET for kits marked *.

MANY MORE KITS (Over 70!) in catalogue.
 ALL KITS incl. pcbs, parts, nice boxes, instructions, free wire and solder. Further details in catalogue.

CATALOGUE AND ENQUIRIES
Send A4 SAE for catalogue, and with all enquiries. (Overseas send £1.00 or 5 I.R.C's).

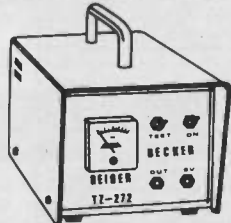

LOW COST GEIGER COUNTERS



NUCLEAR FREE ZONES? CHECK THEM OUT - GET A GEIGER

Detectors for environmental and geological monitoring - know your background! You'd be amazed at the quantities sold since Chernobyl.

METERED GEIGER (PE MK2)
Built-in probe, speaker, meter, digital output. Detector tube options - ZP1310 for normal sensitivity, ZP1320 for extrasensitivity.
 Kit-form - SET 264 - (ZP1310) £59.50, (ZP1320) £74.05
 Ready-built = TZ272 - (ZP1310) £75.50, (ZP1320) £90.05

AUDIO GEIGER (EE MK2)
Built-in probe (ZP1310), speaker, digital output.
 Kit-form SET 265 MK2 £49.50. Ready-built TZ274 £65.00

GEIGER-MITE SET 271 £39.50
Miniature geiger with ZP 1310 tube. LED displays radiation impacts. Socket for headphones or digital monitoring. Kit-form only.

ORDERS AND POST
MAIL ORDER, CWO, CHQ, PO, ACCESS, VISA. Add 15% VAT. Add P&P - SET 234 £3.50, Units 264 & 272 £2.50, others £1.50 each. Insurance 50p per £50. Overseas P&P in catalogue. Text photocopies - DDL £1.50, Geigers £1.00, others 50p each. Send large SAE or 50p post. Maintenance service for our kits available.

PHONOSONICS, DEPT PE72, 8 FINUCANE DRIVE, ORPINGTON, KENT BR5 4ED. TEL: 0689 37821

P.C. BOARDS

Printed circuit boards for certain PE constructional projects are available from the PE PCB Service, see list. They are fully drilled and roller tinned. All prices include VAT and postage and packing. Add £2 per board for overseas airmail. Remittances should be sent to: **PE PCB Service, Practical Electronics, 16 Garway Road, London W2 4NH.** Cheques should be crossed and made payable to **Intrapress.**

Please note that when ordering it is important to give project title, order code and the quantity. Please print name and address in Block Capitals. Do not send any other correspondence with your order.

Readers are advised to check with prices appearing in the current issue before ordering.

NOTE: Please allow 28 days for delivery. We can only supply boards listed here.

TELEPHONE ORDERS (LINES OPEN 24 HOURS)

You can now order your printed circuit boards by telephone, quoting your Access credit number. The number to ring is: 0268 289923. In stock items will be despatched within 24 hours of receipt of order. If you ring out of office hours please state your order, credit card number and address clearly, as the order is recorded on an answering machine.

Power Control Interface		403-01	£5.31
Disc Drive PSU		504-02	£7.79
Modular Audio Power System	APRIL '85		
Pt-3: Test Signal Source		504-09	£4.73
Power Supply		504-10	£4.70
Amstrad Synthesizer Interface		505-01	£4.77
Rugby Clock Pt-2		504-03	£30.84
"	MAY '85	504-05	£5.93
"		504-06	£11.70
"		504-07	£6.30
"		504-08	£12.60
CBM64 Music Keyboard			
Keyboard	JUNE '85	506-02	£5.19
Main PCB		506-03	£3.90
MTX 8 Channel A to D		507-01	£4.37
Voltmeter Memory Adapter	JULY '85	506-01	£3.90
Envelope Shaper	AUG '85	508-01	£4.11
Car Boot Alarm		509-01	£3.90
RS232 To Centronics Converter	SEPT '85	509-03	£5.70
Touch Control PSU		001	£4.90
Exp. with Robots (double-sided)	OCT '85	004	£21.30
Modulated Syndrum		005	£4.90
CBM User Port Expander		006	£4.38
Model Railway Track Control		010	£6.35
*Bytebox: ROM Board (double-sided)		002	£15.89
ZIF Socket		003	£3.90
RAM Board	NOV '85	007	£5.70
Battery Backed RAM		008	£4.13
EPR0M Board		009	£3.90
*Special Price - Complete set of 5 boards		00A	£29.25
Model Railway Track Control	DEC '85		
Rec Board - A		016	£4.33
Rec Board - B		017	£5.60
Rec Board - B Ext		018	£4.38
Test Load		019	£3.03
Exp. with Robots		022	£4.10
Spectrum Speech Synth & 8-Bit I/O Port (double sided)	JAN '86	023	£7.74
Burglar Alarm Main Board		020	£5.73
Bell Driver	FEB '86	021	£3.90
Logic Probe		024	£4.73
Computer Movement Detector		509-02	£3.90

Dear PE,
Please supply the following PCBs:

Board description	Code	Qty	Price
Name & Address:			

Clock Timer		027	£7.58
Fibre Optic Audio Link			
Transmitter	MAR '86	025	£3.90
Receiver		026	£3.90
Set of two boards		00B	£6.90
Hardware Restart (double-sided)		508-02	£8.35
Temperature/Analogue Interface		101	£3.90
Sound Activated Switch		102	£6.17
Photographic Trigger Unit	APRIL '86		
Set of two boards		00C	£7.89
IEEE1000 PSU		105	£5.28
Scratch and Rumble Filter		106	£5.13
Notcher Effects Unit		107	£5.99
Logic Checker	MAY '86	108	£4.59
D.F. Beacon Timer		109	£6.18
STEBus backplane		110	£14.97
Guitar Tracker		111	£6.98
Thermocouple Interface	JUNE '86	112	£3.90
PE Hobby Board		113	£29.00
BBC Light-pen		114	£3.90
Passive IR Detector		115	£3.90
200MHz counter			
Main board	JULY '86	116	£19.14
Display board		117	£14.35
Set of two boards		00D	£30.88
Fibre Optic Data Link			
Set of two boards	SEPT '86	00E	£10.14
PEHB D/A-A/D		120	£7.25
Drum Synthesizer		121	£7.67
Time Delay - Mains (Set of 2)	OCT '86	122	£7.92
Mains Dimmer		123	£3.90
Remote Joystick		124	£10.86
Set of two boards			
Wireless Baby Alarm	NOV '86	125	£10.71
Set of two boards			
Video Enhancer	DEC '86	126	£8.76
Video Fader	JAN '87	127	£4.50
Scrambler		128	£8.06
" (set of two)		128a	£15.21
PE Promenader (double side) main board		129	£30.68
" Power supply		130	£9.53
PE Promenader Playback Unit		133	£14.52
PE Promenader Extension Prom	FEB '87	131	£9.05
PE Hi-Stab		132	£8.79
PE 30 Plus 30		134	£29.50
4 Channel Enhancer		135	£4.60
Light Pen	MAR '87	136	£4.10
Bell Repeater		137	£3.90
Ultrasonic Measure		138	£9.50
PE Vigilante		139	£5.90
SMI PSU Stepper		140	£3.90
" Booster	APR '87	141	£3.90
" Inverter		142	£3.90
Inductive Loop Transmitter		143	£3.90
" " Receiver		144	£3.90

PRACTICAL ELECTRONICS

ADVERTISING DEPT.

FULL-TIME TRAINING COURSES

2 YEAR
B-TEC National Diploma (OND)
ELECTRONICS & COMMUNICATIONS ENGINEERING
(Television & Computing)

15 MONTHS
B-TEC National Certificate (ONC)
ELECTRONIC EQUIPMENT SERVICING
(Television & Video)

15 MONTHS
B-TEC National Certificate (ONC)
COMPUTING TECHNOLOGY

9 MONTHS
B-TEC Higher National Certificate (HNC)
COMPUTING TECHNOLOGY & ROBOTICS

HIGH PERCENTAGE OF COLLEGE BASED PRACTICAL WORK
 SHORT COURSES WITH PREVIOUS KNOWLEDGE
 NO EXTRA CHARGES FOR OVERSEAS STUDENTS
 COURSES COMMENCE
 5th JANUARY/20th APRIL 1987

LONDON ELECTRONICS COLLEGE

Dept: AA, 20 Penywern Road,
 London SW5 9SU. Tel: 01-373 8721

SURPLUS/REDUNDANT ELECTRONIC COMPONENTS WANTED

I/Cs - Tuners - Transistors - Valves - Diodes etc. any quantity considered - immediate payment.

ADM ELECTRONIC SUPPLIES
Tel: 0827 873311

Carbon Film Resistors 1/4W E24 series 0.51R to 10MΩ - 1p
 100 off per value - 75p 1000 off in even hundreds per value - £7
 Metal Film 1/4W 10R0 to 1MΩ 5% E12 series - 2p 1% E24 series - 3p
 BC107/8/9 - 12p BC547/8/9 - 8p BC182L 184L - 10p
 BFY50/51/52 - 20p 2N3055 - 50p TIP31A,32A - 25p TIP,41,42, - 40p

Tantalum head subminiature electrolytics (Mids/Volts)
 0-1/35, 0-22/35, 0-47/35, 3-3/16, 4-7/16 - 14p 4-7/35 - 15p
 2-2/35, 4-7/25, 10/5 - 15p 4-7/35, 6/8/16 - 16p 10/16,22/6 - 20p
 22/16 - 30p 33/10 - 30p 47/10 - 35p 100/6 - 40p

Aluminium Electrolytics (Mids/Volts)
 1/50, 2/2/50, 4-7/50, 4-7/50, 10/16, 10/25, 10/50 - 5p 22/16, 22/25 - 6p
 22/50, 47/16, 47/25, 47/50 - 6p 100/16, 100/25 - 7p 100/50 - 12p
 100/100 - 14p 220/16 - 18p 220/25, 220/50 - 10p 470/16, 470/25 - 11p
 1000/25 - 18p 1000/35, 220/25 - 22p 4700/25 - 70p

Miniature Polyester Capacitors 250V Wkg. Vertical Mounting
 .01, .015, .022, .033, .047, .068 - 4p 0.1 - 5p 0.15, .22 - 6p 0.47 - 8p

Mylar Capacitors 100V Wkg. Vertical Mounting E12 Series
 1000p to 8200p - 3p .01 to .068 - 4p 0.15p 0.15, 0.22 - 6p

Subminiature Ceramic Plate 100V Wkg. E12 Series Vertical Mounting
 2% 1P8 to 47P - 3p 56P to 330P - 4p 10% 390P to 4700P - 4p
 Ceramic plate/disc E6 Series 50V 22P to .047 - 2p

Polystyrene Capacitors 63V Wkg. E12 Series Axial Mounting
 10P to 820P - 3p 1000P to 10,000 - 4p 12,000P - 5p
 1N4148 - 2p 1N4002 - 4p 1N5404 - 14p W01 bridge - 25p
 OA91 - 6p AA143 - 8p W005 - 20p 1N4006 - 6p
 Zener diodes E24 series 3V3 to 33V 400mW - 8p 1 watt - 12p
 L.E.D's Red, Green & Yellow 3mm & 5mm - 10p 8mm - 35p
 20mm fuse 0-1A to 5A quick blow - 5p Anti-Surge - 8p
 High Speed drills 0.8mm, 1.0mm, 1.3mm, 1.5mm, 2mm - 25p
 Expo Reliant drilling machines 12V d.c. with improved 3-jaw chuck 6.50
 Nicads AA - 80p HP11 - £2 PP3 - £4.20 Universal Chargers - £6.50
 Glass reed switches single pole make contacts - 8p Magnets - 12p

VAT inclusive. Return postage 20p (free over £5). Lists free.

THE C.R. SUPPLY CO.,
 127 Chesterfield Road,
 Sheffield S8 0RN. Tel. 557771.

TURN YOUR SURPLUS

ICS transistors etc into cash, immediate settlement. WE also welcome the opportunity to quote for complete factory clearance.

Contact **COLES-HARDING & Co,**
 103 South Brink, Wisbech, Cambs.
ESTABLISHED OVER 10 YEARS*
 Tel: 0945 584188



ELECTRONIC COMPONENTS

- Velleman Electronic Kits
- Test Equipment & Tools
- Instrument Cases

(Mon-Sat. 9.30-5.30 Closed Thurs)

13A Station Rd, Cullercoats, North Shields,
 Tyne & Wear NE30 4PQ. Tel. 091 251 4363

adam hall supplies Ltd.

The largest selection of flight case fittings and loudspeaker cabinet components in Europe.



HARDWARE
SOUND EQUIPMENT

Stockists & Distributors of

CELESTION
 THE FIRST NAME IN ACOUSTICS

A complete range of professional crossovers & filters.

Unit G, The Cordwainers, Temple Farm Industrial Est.,
 Sutton Rd, Southend-on-Sea, Essex Tel: (0702) 613922

MISCELLANEOUS

CLEARING LABORATORY, scopes, generators, P.S.U.'s, bridges, analysers, meters, recorders etc. Tel. 0403-76236.

CUSTOMISED FRONT PANELS

Self adhesive labels to your own design in plastic or aluminium. Wide range of colours. DIY kit available.

FOTOBOARD

Single Sided & Double Sided in a wide range of sizes. SAE for full price list.

MINIATURE CORDLESS SOLDERING IRON

New product - operates from butane gas.

ELECTRONIC ALARM SERVICES

143 Farnham Road, Handsworth, Birmingham B21 8EF.
 Tel: 021-523 6747. Private & professional enquiries welcome

THE SCIENTIFIC WIRE COMPANY

811 Forest Road, London E17. Telephone 01-531 1568

ENAMELLED COPPER WIRE				
SWG	1lb	8 oz	4 oz	2 oz
8 to 34	3.63	2.09	1.10	0.88
35 to 39	3.82	2.31	1.27	0.93
40 to 43	6.00	3.20	2.25	1.61
44 to 47	8.67	5.80	3.49	2.75
48	15.96	9.58	6.38	3.69
SILVER PLATED COPPER WIRE				
14 to 30	9.09	5.20	2.93	1.97
TINNED COPPER WIRE				
14 to 30	3.97	2.41	1.39	0.94
Fluxcore Solder	5.90	3.25	1.82	0.94

Post Free. Please add V.A.T. at 15%. Orders under £2 add 20p SAE for list of copper and resistance wire.
 Dealer enquiries welcome.

ORDER FORM PLEASE WRITE IN BLOCK CAPITALS

Please insert the advertisement below in the next available issue of Practical Electronics for

insertions. I enclose Cheque/P.O. for £.....
 (Cheques and Postal Orders should be crossed Lloyds Bank Ltd. and made payable to Practical Electronics)

NAME

ADDRESS

The prepaid rate for classified advertisements is 20 pence per word (minimum 12 words), box number £1.00 extra. Semi-display setting £8 per single column centimetre (minimum 2.5 cms). All cheques, postal orders, etc. to be made payable to Intrapress and crossed. Treasury notes should always be sent registered post. Advertisements, together with remittance, should be sent to Practical Electronics, 16 Garway Road, London W2 4NH. Tel. (0322) 521069.

d.c.electronics

THE Source For All Your Component Requirements.

ALL components are professional grade, brand new with manufacturers marking and guarantee.

SPECIAL BARGAINS - ONLY £1 EACH

- 200 0.25W resistors, mixed values (max 5 your choice)
- 50 0.4W resistors, mixed values max 5 your choice)
- 40 1N4148 computer diodes
- 30 1N4001 1A power diodes
- 15 BC182L NPN transistors
- 15 BC212L PNP transistors
- 30 Ceramic plate caps - you specify value
- 10 Electrolytic caps 47-470uF - you specify value

Only our catalogue can tell the full story - send SAE (9x6) for your FREE copy now.

Dept. P, 34 The Platters, Rainham, Kent, ME8 0DJ.

Mail order only, cash, PO or cheque with order.
60p P&P. Prices incl VAT.

EDUCATIONAL SOFTWARE

The fundamentals of Electronics.

For Spectrum 48k and higher.

ANALOGUE ELECTRONICS Groups 1-2-3

3 programs on cassette, £9.50

DIGITAL ELECTRONICS Parts 1 to 6

6 programs on cassette, £16

Post free throughout Europe.

Lancing Technical Services Ltd, Dept PE,

54 Grand Ave, Lancing, W. Sussex, BN15 9PZ

SERVICES

DESIGN SERVICES, microprocessor, special interfaces, analogue, digital, signalling, alarm systems, PCB design and artwork. Prototype and small batch production. **ALAB ELECTRONICS**, Grantham (0476) 860089.

SERVICE SHEETS from £2.50/1sae ctv/mus-c/combis £3.50/1sae. Sae Newnes & TVTechnic Books in stock. Thousands Service & Repair Manuals. SAE Free Review/pricelists. TIS (PE), 76 Church St., Larkhall (0698 883334), Lanarkshire.

HEATHKIT U.K. SPARES AND SERVICE CENTRE. Cedar Electronics, Unit 12, Station Drive, Bredon, Tewkesbury, Glos. Tel. (0684) 73127.

MANUFACTURERS OF METAL CASES

Front panels professionally silk screen printed to your own design.

Send details of your requirements for a quotation.

PAYNE ELECTROPRINT LTD

Marcus Road, Dunkeswell, Honiton, Devon EX14 0RA.

COMPONENTS

BARGAIN PACKS - 610 1/2w Carbon Resistors 2,5,10%. 10 each value E12 Series. £3.00 inclusive. Also 1000 of above, good mix £2.50 inclusive P&P Many other items in stock. Write for free list. D.M. Evans 12 Vicarage Hill, Rhoslyten, Wrexham, CLWYD LL14 4AR.

1000's New 500mm R/G L-E-D's. 0.09p. P&P 0.50p. Pay "Mr K. Varia": 70 Combrook Road, Aylesbury, Bucks.

Free with latest catalogue - massive savings! I.C. Electronics is the source of high quality discount components, electrical and electronics. Send name, address + £1. (Refundable): I.C. Electronics, Mail Order Dept A2, P.O.Box 130, Aberdeen AB9 8HQ.

Quality Walkie Talkies 49MHZ, long range satisfaction or refund. £24.99/pair (normally £31.49), 48hrs delivery. Xenon (Dept PE9) 24 Wharnclyffe Street, Barnsley, Yorkshire.

LEDSCOPE

Ledscope is intended to form the nucleus of an electronics constructor/enthusiasts workstation, incorporating a low frequency oscilloscope with high eff. LED display, direct reading voltmeter and ohm-meter.

Kit of parts (excluding case) £49.95
Custom designed case £14.95
Scope probe/test lead kit £7.95

All prices include VAT,
please add £2.50 p. & p.

For further information send S.A.E.

LEFAX LTD

Unit 6, Genesis Business Centre,
Redkin Way, Horsham,
West Sussex RH13 5QH.
Tel: (0403) 54135

Free Membership to a new national electronics club. For details and a free pack of components worth over £10 send only £1 p&p to Dept PEWoodside, Dowsett Lane, Ramsden Heath, Billericay, Essex CM11.

**PLEASE MENTION
PRACTICAL
ELECTRONICS
WHEN REPLYING
TO ADVERTISING**

TO ADVERTISE ON THESE PAGES
TEL: 01-727 7010

PE BAZAAR

Tandy DX200L Receiver Covers all band to 30MHZ nearly new condition very little used £75. Phone 0792 582941.

Cash paid for early transistor types, any condition. Send your list or write for full details. Dr A. Wylie, 5 Lyncroft Gardens, West Hampstead, London NW6.

Eight inch double disc drive plus 15 discs. Perfect condition £100. Buyer must collect. A. Ingles, 7 Castleroy Road, Broughty Ferry, Dundee.

Help, can anybody tell me how to use the sequencer interface on the PE Micro Synth? D. Snowdon, 124 Warpole Road, South Woodford, London, E18 2LL.

Complete set Practical Electronics from Vol 1 No.1 November 1964 to this month. Would suit Library. Offers. Mr. C.H. Pither, The Willows, 54 Pack Lane, Oakley, Nr Basingstoke, Hants, RG23 7BJ. Phone Basingstoke 780764.

C64 Modem still in box used twice, £50. Cardiff 0222 384877 after 2pm. P.T. Collins, 39 Dalton Street, Cathays, Cardiff, CR2 4HB.

Reasonable fee paid to anyone who will keep me informed of latest electronic products. J. Fulton, Derrynaseer, Dromore, Co. Tyrone, BT78 3BE.

Spectrum 16K with printer, cassette player, 8 games and three extra books. £80 O.N.O. Mr. I. Spearman, 18 Queensway, Shelley, Ongar, Essex, CM5 0BN.

Beeper for Page Alert 4444T wanted. Phone 021 328 3994 evenings. L. Rudd, 26 Sladefield Road, Ward End, Birmingham, B8 3NX.

INDEX TO ADVERTISERS

A.D.M. Electronic Supplies	61	C.W. Howes	56
Audiokits	18	I.C.S.	58
BiPak Components	55	J.M.J. Electronics	62
B.K. Electronics	19	Lancing Technical Services	62
Camboard	18	Lefax	62
Cambridge Learning	39	London Electronics College	61
C.I.L.	IFC	Magenta Electronics	IFC
Cirkit	59	M.J.R. Wholesale	58
Coles Harding	61	Maplin Electronics	0BC
C.P.L. Electronics	39	Mendascope	58
Cricklewood Electronics	56	Nebulae	39
Crofton Electronics	38	No One Systems	18
Croydon Disco	58	Omni	58
C.R. Supply Co.	61	Phonosonics	59
D.C. Electronics	62	Prentice Hall	38
Dispay Electronics	IBC	Riscomp	16
E.S.R. Electrical Components	61	Scientific Wire Co.	61
Electronic Alarm Services	61	Service Trading Co.	39
Gatehouse Audio	56	Stewart of Reading	59
Grandata	58	Tandy	17
Greenweld Electronics	51	Technomatic	10,11
Hall Supplies, Adam	61	T.K. Electronics	51
Hart Electronic Kits	55		

- ★ 6502 MICROPROCESSOR CONTROL CARD
- ★ 2K SRAM SUPPORTS 8K EPROM
- ★ 6522 VIA 16 LINES OF I/O WITH HANDSHAKE
- ★ ASSEMBLED OR IN KIT FORM
- ★ FULL HARDWARE AND SOFTWARE BACKUP
- £55 ASSEMBLED £46.40 INKIT FORM £30 BARE BOARD
- Plus Postage & Packing
- ★ SUBSTANTIAL REDUCTIONS FOR LARGE ORDERS

For further details
JMJ ELECTRONICS
14, BLENHEIM CLOSE
SHEPRETH
NR. ROYSTON
HERTS SG8 6PT
ROYSTON (0763) 62184

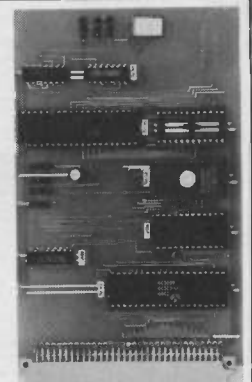

ELECTRONICS

COMPUTER WAREHOUSE

1000's OF BARGAINS FOR CALLERS

THE "ALLADINS' CAVE OF COMPUTER AND ELECTRONIC EQUIPMENT"

HOT LINE DATA BASE

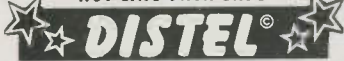

The ORIGINAL FREE OF CHARGE dial up data base. BUY, browse or place YOUR OWN AD for goods or services to sell. 1000's of stock items, spares and one off bargains. Updated daily. **ON LINE NOW.** CCITT, 8 bit word, no parity. For 300 baud modems call 01-679 1888. For 1200-75 baud modems call 01-679 6183

FREE

Your monitor from its computer!! For only £29.95 it becomes a SUPERB HIGH QUALITY * COLOUR * TV SET

The fabulous TELEBOX, an INVALUABLE MUST for the owner of ANY video monitor with a composite input, colour or monochrome. Made by a major UK Co. as a TOP QUALITY, stand alone UHF tuner and costing OVER £75 to manufacture, this opportunity to give your monitor a DUAL FUNCTION must not be missed!! The TELEBOX consists of a compact, stylish two tone charcoal moulded case, containing ALL electronics tuner, power supply etc to simply plug in and convert your previously dedicated computer monitor into a HIGH QUALITY COLOUR TV SET, giving a real benefit to ALL the family!! Don't worry if your monitor doesn't have sound - THE TELEBOX even has an integral 4 watt audio amplifier for driving an external speaker, PLUS an auxiliary output for superb quality television sound via your headphones or HI FI system etc. Other features include: Compact dimensions of only 15.75" w x 7.5" d x 3.5" h, latest technology, BRITISH manufacture, fully tuneable 7 channel push button tuner, Auto AGC circuit, SAW filter, LED status indicator, fully isolated 240v AC power supply for total safety, Mains ON-OFF switch etc. Many other uses.

LIMITED QUANTITY - DON'T MISS THIS OFFER!! ONLY £29.95 OR £24.95 if purchased with ANY of our video monitors. Supplied BRAND NEW with full instructions and 2 YEAR warranty. Post and packing £3.50 *When used with colour crt.

COLOUR & MONOCHROME MONITOR SPECIALS

'SYSTEM ALPHA' 14" COLOUR MULTI INPUT MONITOR

Made by the famous REDIFUSION Co. for their own professional computer system this monitor has all the features to suit your immediate and future requirements. Two video inputs: RGB and PAL Composite Video, allow direct connection to BBC/IBM and most other makes of micro computers or VCR's. Including our very own TELEBOX. An internal speaker and audio amp may be connected to computer or VCR for superior sound quality. Many other features: PIL tube, Matching BBC case colour, Major controls on front panel, Separate Contrast and Brightness - even in RGB mode. Separate Colour and audio controls for Composite Video input, BNC plug for composite input, 15" way 'D' plug for RGB input, modular construction etc.

This Must Be ONE OF THE YEAR'S BEST BUYS. PC USER Supplied BRAND NEW and BOXED, complete with DATA and 90 day guarantee. ONLY £159.00 as above OR IBM PC Version £165.00 15 Day 'D' skt £1.00, BNC skt 75p BNC interface cable £5.50

DECCA 80 16" COLOUR monitor. RGB input. Little or hardly used manufacturer's surplus enables us to offer this special converted DECCA RGB Colour Video TV Monitor at a super low price of only £99.00, a price for a colour monitor as yet unheard of!! Our own interface, safety modification and special 16" high definition PIL tube, coupled with the DECCA 80 series TV chassis give 80 column definition and quality found only on monitors costing 3 TIMES OUR PRICE. The quality for the price has to be seen to be believed!! Supplied complete and ready to plug direct to a BBC MICRO computer or any other system with a TTL RGB output. Other features are: internal speaker, modular construction, auto degaussing circuit, attractive TEAK CASE, compact dimensions only 52cm W x 34 H x 24 D, 90 day guarantee. Although used, units are supplied in EXCELLENT condition. ONLY £99.00 + Carriage.

DECCA 80, 16" COLOUR monitor. Composite video input. Same as above model but fitted with Composite Video input and audio amp for COMPUTER, VCR or AUDIO VISUAL use. ONLY £99.00 + Carr.

REDIFUSION MARK 3, 20" COLOUR monitor. Fitted with standard 75 ohm composite video input and sound amp. This large screen colour display is ideal for SCHOOLS, SHOPDS, DISCOS, CLUBS and other AUDIO VISUAL applications. Supplied in AS NEW or little used condition ONLY £145.00 + Carr.

BUDGET RANGE EX EQUIPMENT MONOCHROME video monitors. All units are fully cased and set for 240v standard working with composite video inputs. Units are pre tested and set up for up to 80 column use. Even when MINOR screen burns exist - normal data displays are unaffected. 30 day guarantee. 12" KGM 320-1 B/W bandwidth input, will display up to 132 x 25 lines. £32.95 12" GREEN SCREEN version of KGM 320-1. Only £39.95 9" KGM 324 GREEN SCREEN fully cased very compact unit. Only £49.00 Carriage and insurance on all monitors £10.00

DC POWER SUPPLY SPECIALS

GOULD OF443 enclosed, compact switch mode supply with DC regulated outputs of +5v @ 5.5a, +12v @ 0.5a, -12v @ 0.1a and -23v @ 0.02a. Dim 18 x 11 x 6 cm. 110 or 240v input. BRAND NEW only £16.95 GOULD G6-40A 5v 40 amp switch mode supply NEW £130.00 AC-DC Linear PSU for DISK drive and SYSTEM applications. Constructed on a rugged ALLOY chassis to continuously supply fully regulated DC outputs of +5v @ 3 amps, -5v @ 0.6 amps and +24v @ 5 amps. Short circuit and overvoltage protected. 100 or 240v AC input. Dim 28 x 12.5 x 7 cm NEW £49.94 Carriage on all PSU's £3.00

KEYBOARDS

Manufacturer's BRAND NEW surplus DEC L434 Uncoded keyboard with 67 quality gold plated switches on X-Y matrix - ideal micro conversions etc. £24.95 AMKEY MPNK-114 Superb word processor chassis keyboard on single PCB with 116 keys. Many features such as On board Micro, Single 5v rail, full ASCII coded character set with 31 function keys, numeric keypad, cursor pad and 9600 baud SERIAL TTL ASCII OUTPUT!! Less than half price ONLY £69.00 with data. Carriage on Keyboards £3.50



PC2000 System with CPM Etc. COST OVER £1400

NOW only £399

DON'T MISS THE CPM Deal of the CENTURY The FABULOUS CPM TATUNG PC2000 Professional Business System

A cancelled export order and months of negotiation enables us to offer this professional PC, CPM system, recently on sale at OVER £1400, at a SCOOP price just over the cost of the two internal disk drives!! Or less than the price of a dumb terminal!!

Not a toy, the BIG BROTHER of the EINSTEN computer, the DUAL PROCESSOR PC2000 comprises a modern stylish three piece system with ALL the necessities for the SMALL BUSINESS, INDUSTRIAL, EDUCATIONAL or HOBBYIST USER. Used with the THOUSANDS of proven, tested and available CPM software packages such as WORDSTAR, FAST, DBASE2 etc, the PC2000 specification, at our prices. CANNOT BE BEATEN!!

The central processor plinth contains the 64K, Z80A processor, DUAL TEAC 55F 5 1/4" 1Mb per drive, PSU, 4K of memory mapped screen RAM, disk controller, RS232, CENTRONICS and system expansion ports, and if that's not enough a ready to plug into STANDARD 8" DRIVE port for up to FOUR 8" disk drives, either in double density or IBM format. The ultra slim 92 key, detachable keyboard features 32 user definable keys, numeric keypad and text editing keys, even its own integral microprocessor which allows the main Z80A to devote ALL its time to USER programs, eliminating "lost character" problems found on other machines. The attractive, detachable 12" monitor combines a green, anti-glare etched screen, with full swivel and tilt movement for maximum user comfort. Supplied BRAND NEW with CPM 2.2, user manuals and full 90 day guarantee. Full data sheet and info on request.

PC2000 Business System with CPM and 'Ready to Run' FAST Sales and Purchase ledger, supports up to 9000 Accounts, VAT etc. COST OVER £1700

PC2000 Wordprocessor System with CPM and TEC FP25 daisywheel printer. **NOW only £799**

NOW only £499 Carriage & Insurance £12.00

MODEMS

Join the communications revolution with our super range of DATA MODEMS, prices and specifications to suit all applications and budgets....

- BRAND NEW State of the art products
- DACOM DSL2123 Multi standard 300-300, 1200-75 Auto answer etc. £268.00
- DACOM DSL2123AQ Auto dial, smart modem with multi standard AUTO SPEED detect, and data buffer with flow control etc. £365.00
- DACOM DSL2123GT THE CREAM of the intelligent modems, auto dial, auto call, index, buffer etc etc. £498.00
- Steack SB1212 V22 1200 baud FULL DUPLEX, sync or async, optional auto dial. £465.00
- TRANSDATA 307A Acoustic coupler 300 baud full duplex, originate only, RS232 interface. £49.00

Ex BRITISH TELECOM full spec, CCITT, ruggedised, bargain offers. Sold TESTED with data. Will work on any MICRO or system with RS232 interface. MODEM 13A 300 baud unit, only 2" high fits under phone CALL mode only. £45.00 MODEM 20-1, 75-1200 baud. Compact unit for use as subscriber end to PRESTEL, TELECOM GOLD, MICRONET etc. £39.95 +pp£6.50 MODEM 20-2 1200-75 baud. Same as 20-1 but for computer end. £65.00 +pp£6.50 DATEL 2412. Made by SE Labs for BT this two part unit is for synchronous data links at 1200 or 2400 baud using 2780/3780 protocol etc. Many features include 2 or 4 wire working, self test, auto answer etc. COST OVER £800. Our price ONLY £199 +pp£8.00 DATEL 4800, RACAL MPS4800 baud modem, EX BT good working order, ONLY £295.00 +pp £8.00

SPECIAL OFFER

MODEM TG2393, EX BT, up to 1200 baud, full duplex 4 wire or half duplex over 2 wire line. ONLY £85.00 PER PAIR +pp£10.00

For more information contact our Sales Office.

MATRIX PRINTERS

SPECIAL BULK PURCHASE of these compact, high speed matrix printers. Built in Japan for the Hazeltine Corporation this unit features quality construction giving 100cps bidirectional, full pin, addressable graphics, 6 type fonts, up to 95" single sheet or tractor paper handling, RS232 and CENTRONICS parallel interface. Many other features. BRAND NEW and BOXED. COST £420. Our price ONLY £199.00

RECHARGEABLE BATTERIES

Dry Fit MAINTENANCE FREE by Sonnenschein & Yuasa. A300 07191315 12v 3Ah NEW £13.95 A300 07191312 6v 3Ah NEW £9.95 A300 07191202 6-0-6v 1.8Ah TESTED Ex Equip £5.99

VDU TERMINALS

Standard VDU data entry terminals at give away prices!!

QUME QVT108, Current product, state of the art terminal with detachable keyboard, 12" Green screen, 2 page RAM, TVI 925, Hazeltine, ADMSA emulations, software setup, 25 x 80, Clock, Swivel and tilt base, Printer port, Function keys etc. BRAND NEW and BOXED AT ALMOST HALF PRICE ONLY £425.00 AJ510 - EX RENTAL, Z80 controlled, 15" green screen 24 x 80 display, graphics, cursor addressing, printer port etc. Very good condition TESTED complete with manual only £225.00 ADDS £20 - Dumb terminal, used, 12" b/w screen RS232 interface and printer port. TESTED. ONLY £125.00. Carriage on terminals £10.00 100's of other terminals in stock, CALL for more details.

SURPLUS SPECIALS ON PRESTEL - VIEWDATA - TELEX

PLESSEY VUTEL, ultra compact unit, slightly larger than a telephone features A STANDARD DTMF TELEPHONE (tone dial) with 5" CRT monitor and integral modem etc. for direct connection to PRESTEL, VIEWDATA etc. Designed to sell to the EXECUTIVE at over £600! Our price BRAND NEW AND BOXED at only £99.00

DECCA FAX VP1 complete Professional PRESTEL system in slimline desk top unit containing Modem, Numeric keypad, CPU, PSU etc. Connects direct to standard RGB colour monitor. Many other features include: Printer output, Full keyboard input, Cassette port etc. BRAND NEW with DATA. A FRACTION OF COST only £55.00

ALPHATANEAL. Very compact unit with integral FULL ALPHA NUMERIC keyboard. Just add a domestic TV receiver and you have a superb PRESTEL system and via PRESTEL the cheapest TELEX service to be found!! Many features: CENTRONICS Printer output, Memory dialling etc. Supplied complete with data and DIY mod for RGB or Composite video outputs. AS NEW only £125.00

Post and packing on all PRESTEL units £8.50

EX-STOCK INTEGRATED CIRCUITS

4164 200 ns D RAMS 9 for £11 4116 ns £1.50 2112 £10.00 2114 £2.50 2102 £2.00 6116 £2.50 EPROMS 2716 £4.50 2732 £3.00 2764 £4.95 27128 £5.50 6800 £2.50 6821 £1.68A09 £8 68B09 £10 80B85 £5.50 80B8 £15 80B8 £8 NEC765 £8 WD2793 £28 8202A £22 8251 £7 8748 £15 Z80A DART £6.50 Z80A CPU £2.00. Thousands of IC's EX STOCK send SAE for list.

DISK DRIVES

Japanese 5 1/4" half height, 80 track double sided disk drives by TEAC, CANON, TOSHIBA etc. Sold as NEW with 90 day guarantee. ONLY £85.00 DEC FB-503 Double sided HH 40 TRK NEW £75.00 SUGART SA400 SS FH 35 TRK £55.00 SIEMENS FDD1 00 SS FH 34 TRK £65.00 carriage on 5 1/4" drives £5.50 Brand NEW metal 5 1/4" DISK CASES with internal PSU. DSKC 1 for 1 HH or 1 FH drive £29.95 +pp £4.00 DSKC 2 for 1 HH drive £22.95 +pp £3.50 DKSC 3 As DSK1 LESS PSU £12.95 +pp £2.50 DSKG 4 As DSK2 LESS PSU £10.95 +pp £2.00 8" IBM format TESTED EX EQUIPMENT. SHUGART 800/801 SS £175.00 +pp £8.50 SHUGART 851 DS £250.00 +pp £8.50 TWIN SHUGART 851* 2 Mb total capacity in smart case, complete with PSU etc. £595.00 MITSUBISHI M2894-83 8" DS 1 Mb equiv. to SHUGART SA850R. BRAND NEW at £275.00 +pp £8.50 DYSAN 8" Alignment disk £29.00 +pp £1.00 Various disk drive PSU's Ex Stock SEE PSU section.

HARD DISK DRIVES DRE/DIABLO Series 30 2.5 Mb front load £25.00 Exchangeable version £295.00. ME3029 PSU £95.00 DIABLO 44/DRE4000A, B 5+5 Mb from £750.00 CDC HAWK 5+5 Mb £795.00. CDC 9782 80 Mb RMO3 etc. £2500.00. PERTEC D3422 5+5 Mb £495.00. RODIME 5 1/4" Winchester ex-stock from £150 CALL Clearance Items - Sold as seen - No guarantee. ICL 2314 Brand NEW 14" Mb Removable pack hard disk drive, cost over £2000 with data ONLY £99.50 BASF 6172 8" 23Mb Winchester £199.00 Unless stated all drives are refurbished with 90 day guarantee. Many other drives and spares in stock - call sales office for details.

All prices quoted are for U.K. Mainland, paid cash with order in Pounds Sterling PLUS VAT. Minimum order value £2.00. Minimum Credit Card order £10.00. Minimum BONA FIDE account orders from Government Depts., Schools, Universities and established companies £20.00. Where post and packing not indicated please ADD £1.00 + VAT. Warehouse open Mon-Fri 9.30-5.30. Sat 10.30-5.30. We reserve the right to change prices and specifications without notice. Trade, Bulk and Export

32 Biggin Way, Upper Norwood, London SE19 3XF Telephone 01-679 4414 Telex 894502 Data 01-679 1888



IN METERS ... WE'RE MILES AHEAD

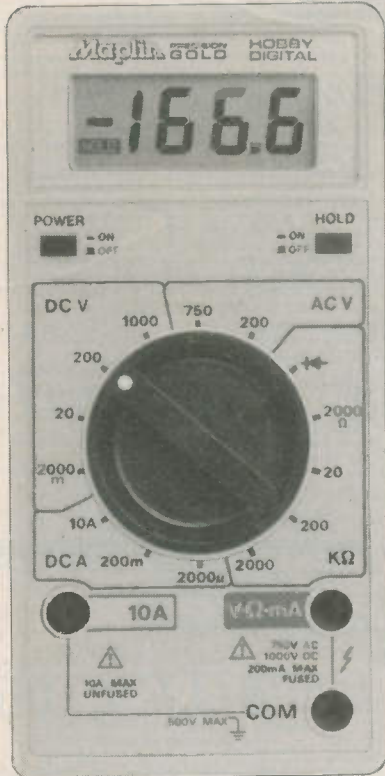
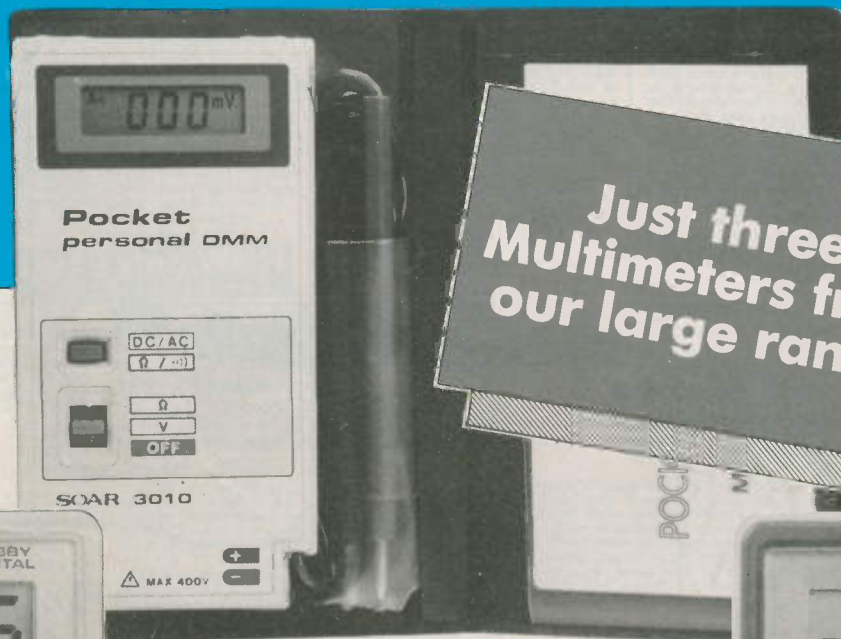

▲ Pocket Digital Multimeter

A calculator size autoranging DMM which reads 1mV-400V DC, 1mV-400V AC, 0.1Ω-2MΩ and has a continuity buzzer. Overall size only 120 x 75 x 15mm. Order Code YN78K **Price £24.95**

◀ Hobby Digital Multimeter

A very high quality multimeter at a very low price! 14 selectable ranges covering AC and DC volts, DC current and resistance. Also has a diode junction test range. Order Code YM63T **Price £28.95**

▶ Auto Ranging Digital Multimeter with Transistor Tester

A 6 position rotary switch selects off, volts, ohms/continuity, 20MΩ, 200mA/h_{FE} or 10A. Features include display hold, NPN and PNP transistor tester, autorange override and low battery indication. Order Code YM64U **Price £45.95**

All prices include VAT. Please add 50p towards postage. Prices firm until 9th May 1987. Subject to availability.



Maplin ELECTRONIC SUPPLIES LTD.

Mail Order: P.O. Box 3, Rayleigh, Essex SS6 8LR. Tel: Southend (0702) Sales: 554161, Enquiries: 552911; Trade sales: 554171, Trade enquiries: 552961.

Shops

Birmingham: Lynton Square, Perry Barr. Telephone: 021 356 7292.

London: 159-161 King Street, Hammersmith W6. Telephone: 01 748 0926.

Manchester: 8 Oxford Road. Telephone: 061 236 0281.

Southampton: 46-48 Bevois Valley Road. Telephone: 0703 225831.

Southend-on-Sea: 282-284 London Road, Westcliff-on-Sea, Essex. Tel: 0702 554000.

All shops except Manchester closed all day Monday.

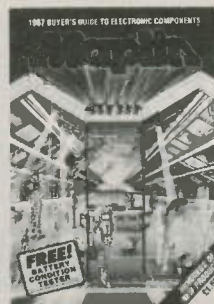

Pick up a copy of our 1987 catalogue from any branch of W.H. Smith for just £1.50. Or to receive your copy by post just send £1.50 + 40p p & p to Mail Order address. If you live outside the U.K. please send £2.50 or 11 International Reply Coupons.