

Australia \$1.75 New Zealand \$1.95 Malaysia \$4.96

PRACTICAL

MAY 1985 · £1.00

ELECTRONICS

ROBOTICS · MICROS · ELECTRONICS · INTERFACING



**AMSTRAD
Synthesiser
Interface**

Cylinder Thermostat

Stereo Noise Gate & VCA

Electronics at the BBC

LEARNING TOOLS

P101Mk2

The P101 Mk 2 Hydraulic Robot Arm offers unrivalled value for money in the field of educational robots. Either as a self-contained system or linked to an external micro, the P101 Mk 2 gives a realistic simulation of industrial robots. The P101 Mk 2's robust construction makes it an excellent basis for experimentation and general robotics research. Six-axis Robot System kit **£1320 + VAT**

P102Mk2

The two-speed Hydraulic Robot Arm is designed to provide "hands-on" experience in practical robotics courses. The Genesis P102 Mk 2 has most of the features of large industrial robots costing from 10 times the price. The P102 Mk 2 is supplied with its own micro-processor control system and remote control box. Alternatively an external microcomputer can be used to control the robot via its RS232C interface or parallel port. Complete Six-axis Robot System kit **£1785 + VAT**

Powertran kits are complete down to the last nut and bolt, with easy-to-follow assembly instructions.

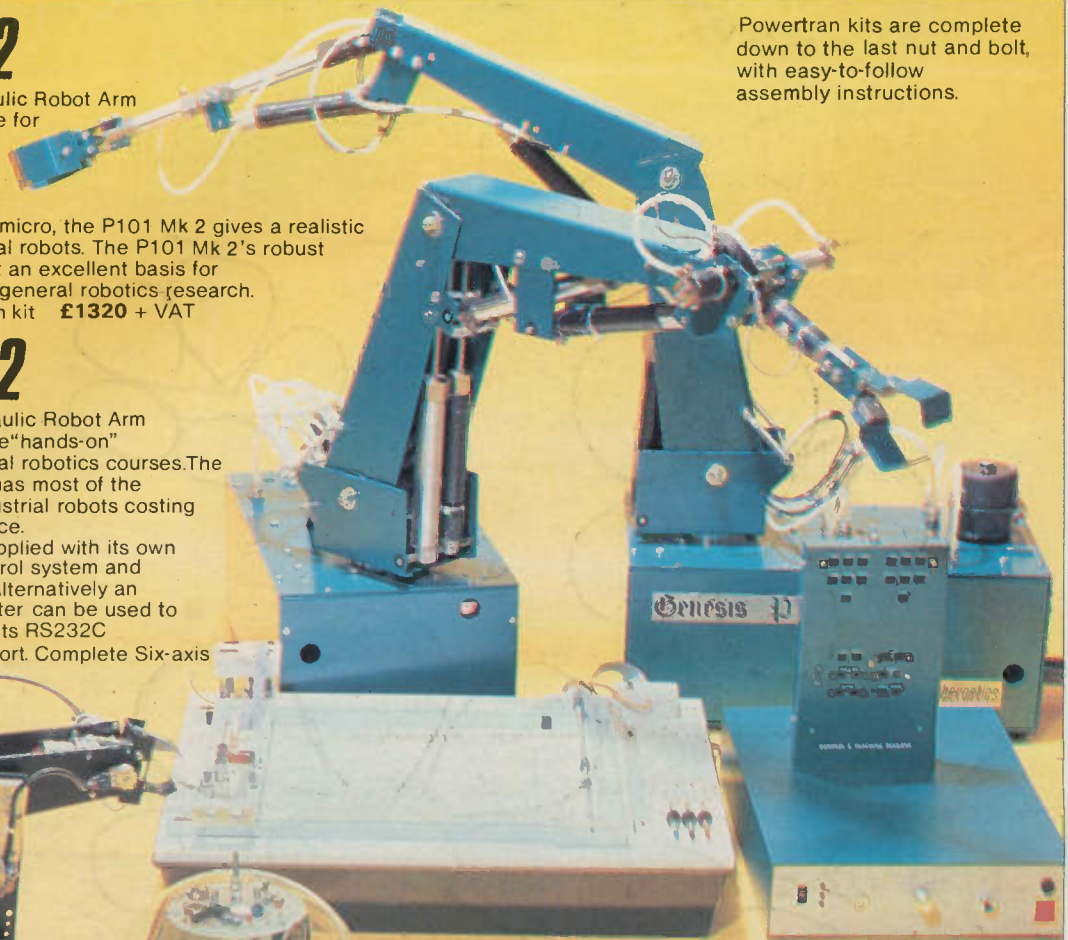

Designed & produced by Mike Carding Advertising
Fareham 286211

POWERTRAN PLOTTER

Three-colour precision plotting on an A3 plane. This plotter is one of the most versatile peripherals that can be bought. Exchange the pen carriage for a router or a scriber for computer-controlled etching or machining. Available for BBC "B" or RML 380Z. **£270 + VAT**

HEBOT II

With independent control of its two wheels, two-tone hooter, flashing "eyes", retractable pen and four-way collision detectors, Hebot provides an ideal introduction to computer control. Connects to most popular micros. Complete kit **£95 + VAT**
Universal computer interface board kit **£11 + VAT**

Access/Visa cardholders - save time - order by phone: 0264 64455.

MICROGRASP

A real programmable robot for the price of a printer! MicroGrasp has four servo-controlled axes and an independent gripper. The robot can be connected to most popular computers via special Powertran adaptors. Robot kit with power supply **£215 + VAT**
Universal interface board kit **£57 + VAT**

POWERTRAN

CYBERNETICS LIMITED

Please send me the following kits _____

I enclose Cheque/Postal Order, value £ _____
(Don't forget to add V.A.T.)

Name _____

Address _____

To Powertran Cybernetics Limited, Portway Industrial Estate, Andover, Hampshire SP10 3PE

Please allow 21 days for delivery. Offers subject to availability. Prices apply to UK only, are exclusive of V.A.T. and correct at time of going to press. Overseas customers - please contact our Export Department.



CONSTRUCTIONAL PROJECTS

AMSTRAD SYNTHESISER INTERFACE by R. A. Penfold	10
1000 note, 5 octave sequencer—computer project	
STEREO NOISE GATE & VCA by John M. H. Becker	14
Reduces noise for musicians and home studio recording	
REMOTE SENSING THERMOMETER by Tom Gaskell BA(Hons) CEng MIEE	22
A 3½ digit electronic thermometer	
TELEPRINTER INTERFACE by B. Drake	26
Low cost letter quality prints from your computer	
CYLINDER THERMOSTAT by Mark Stuart	38
Enables economic use of hot water system	
RUGBY CONTROLLED CLOCK—Part 2 by Stephen Ibbs	53
Construction and setting up procedures	

GENERAL FEATURES

SEMICONDUCTOR CIRCUITS by Tom Gaskell BA(Hons) CEng MIEE	19
Temperature sensor (LM35)	
SPACEWATCH by Dr. Patrick Moore OBE	24
ELECTRONICS AT THE BBC by Chris Kelly	32
Inside the VAX 11/750 and the Quantel 7001 (Paintbox)	
BBC MICRO FORUM by D. Whitfield MA MSc CEng MIEE	44
We pop a numerical keypad into the cauldron	
BBC MICRO PRINTER SOFTWARE by Michael Tooley BA & David Whitfield MA MSc CEng MIEE	46
We look at two dedicated printer ROMs	

NEWS & COMMENT

EDITORIAL	7	NEXT MONTH	37	LEADING EDGE	58
NEWS & MARKET PLACE	8	BAZAAR	49	P.C.B. SERVICE	59
		INDUSTRY NOTEBOOK	50		



This month's cover shows details of a probe card in use at Motorola's East Kilbride facility.

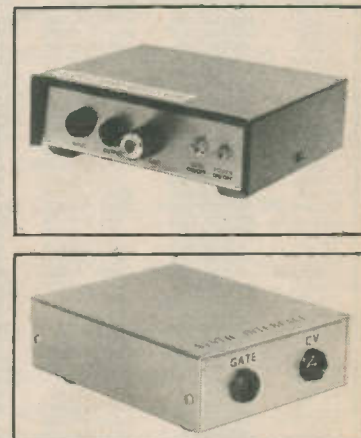
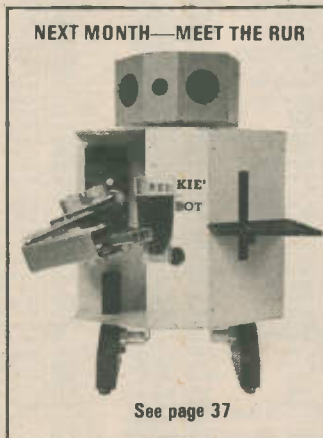

OUR JUNE ISSUE WILL BE ON SALE FRIDAY, MAY 3rd, 1985 (see page 37)

© IPC Magazines Limited 1985. Copyright in all drawings, photographs and articles published in PRACTICAL ELECTRONICS is fully protected, and reproduction or imitations in whole or part are expressly forbidden. All reasonable precautions are taken by PRACTICAL ELECTRONICS to ensure that the advice and data given to readers are reliable. We cannot, however, guarantee it, and we cannot accept legal responsibility for it. Prices quoted are those current as we go to press.

Tandy® Top Value In Test Equipment



Select the Function and It
Selects the Range
Automatically

£22⁹⁵



£69⁹⁵



- Folds Into Compact Case With Wrist Strap

- Automatic Power Off When Case Is Shut
- Automatic Polarity

A 25-Range Folding Multimeter. Features include fuse and surge-absorber protection, banana-type probe jacks and 4" 3-colour mirrored meter with automatic shunt protection (when folded shut). DC Volts: 0 to 1200. AC Volts: 0 to 1200. DC Current: 0-60 μ A, 3-30-300 mA. Resistance: 0.2-20-200K-2 megohms (centre scale 24). dB; -20 to +63 dB. Requires "AA" battery. 22-211 **£22.95**

B Folding LCD Multimeter With Autoranging. Features extra large 1 1/16" non-glare display with adjustable viewing angle, a "beep" indicator for quick continuity testing, and zero-ohms adjust for super-accurate low resistance measurements. DC volts to 1000. AC volts to 500. Up to 10 amps AC and DC. Resistance to 2 megohms. Open: 10 7/8 x 4 5/8 x 1 1/2". Requires two "AA" batteries. 22-193 .. **£69.95**

Transistor Checker and Digital Logic Probe



A **£9⁹⁵**

£14⁹⁵ **B**

A Dynamic Transistor Checker. Makes Go/No-Go tests on small-signal and power types and allow you to match similar transistors. Indicates relative current gain, "opens" and "shorts". Requires "AA" battery. 22-025 **£9.95**

B Digital Logic Probe. The fast way to "peek inside" TTL, LS and CMOS digital circuits. Colour-coded LEDs indicate high, low or pulsed logic states (up to 10 MHz). Minimum detachable pulse width: 50 ns. 36" leads with clips obtain power from circuit under test. Low current drain. 22-302 **£14.95**



Overload
and
Polarity
Protected

Reference Books



A

B

C

A Semiconductor Reference Guide. 1985 edition! Exclusive cross-reference and substitution section lists over 80,000 types. 276-4008 **£4.49**

B Getting Started In Electronics. The perfect introduction to the exciting world of electronics. Learn to build your own circuits. 128 pages. 276-5003 **£2.49**

C Timer IC Mini-Notebook. An excellent reference and hobby book. Large schematic diagrams. 32 pages. 276-5010 **99p**



Take A Look At Tandy, Today!

Visit your local store or dealer and see these and many more bargains. We service what we sell - over, 2,800 exclusive lines!

See Yellow Pages For Address Of Store Nearest You



Ask about
Your Tandy
Personal Charge
Card Today!

OVER 9,000 STORES & DEALERSHIPS WORLDWIDE



Known As Radio Shack In The U.S.A.
Prices may vary at Dealers
Offers subject to availability

TOO LONG

BACK in the early days of semiconductors many users were asking about life expectancy. After all this was something new that would be used in significant quantities in a vast range of equipment. With various devices still working continually after twenty years in certain applications—submarine repeaters being the most obvious—semiconductors have more than proved themselves. In fact they have proved so reliable that they are very often outdated before they wear out. Many manufacturers would also say that they last too long, there being only a very small replacement market.

While problems have been found in track migration on printed circuit boards and even migration of silicon used in cleaning fluids, which can contaminate electrical contacts, little problems have been discovered in basic semiconductor operation. Perhaps the outstanding development pace of new manufacturing processes has something to do with this as technology moves on before lengthy reliability periods have elapsed. If a particular component is found to fail it is likely to be replaced by another device and therefore the problems are often not investigated.

All this gives us some headaches with the projects we publish. The general longevity of semiconductors means equipment lasts for many years before it fails; the project you built five or more years ago is likely

to still be working. That is fine while it is still working but when the unit fails the problems start.

OBSELETE

These days semiconductor manufacturers tend to deem their products obsolete after a few years, sometimes after a few months if particular specialist devices are not very successful. When your project fails it is quite possible that the replacement part required is no longer available. In essence we are being pushed by obsolescence into accepting that when equipment fails it has become a throw-away item.

This has forced us to advise readers not to contemplate any project more than five years old and that we simply cannot provide information, data, diagrams or advice on any article more than five years old. It is quite surprising that many readers pick outdated designs to try and construct when more modern technology often provides a better and cheaper alternative.

So we are sorry to say that we do not advise construction of anything published too long ago and even after a year or so we recommend checking that all parts are available before you start buying.

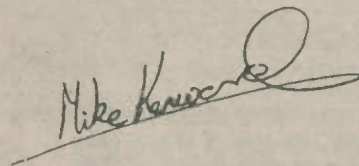

Editor Mike Kenward

Secretary Pauline Mitchell

Editorial Tel: Poole (0202) 671191

Advertisement Manager
David Tilleard 01-261 6676

Secretary
Christine Pocknell 01-261 6676

Classified Supervisor
Barbara Blake 01-261 5897

Ad. Make-up/Copy
Brian Lamb 01-261 6601

Queries and letters concerning

advertisements to:
Practical Electronics Advertisements,
King's Reach Tower,
Stamford Street, London SE1 9LS
Telex: 915748 MAGDIV-G

Letters and Queries

We are unable to offer any advice on the use or purchase of commercial equipment or the incorporation or modification of designs published in PE. All letters requiring a reply should be accompanied by a stamped addressed envelope, or addressed envelope and international reply coupons, and each letter should relate to **one published project only**.

Components are usually available from advertisers; where we anticipate difficulties a source will be suggested.

Old Projects

We advise readers to check that all parts are still available before commencing any project in a back-dated issue, as we cannot guarantee the indefinite availability of components used.

Technical and editorial queries and letters to:

Practical Electronics Editorial,
Westover House,
West Quay Road, Poole,
Dorset BH15 1JG

BACK NUMBERS and BINDERS . . .



Copies of most of our recent issues are available from: Post Sales Department (Practical Electronics), IPC Magazines Ltd., Lavington House, 25 Lavington Street, London SE1 0PF, at £1 each including Inland/Overseas p&p. When ordering please state title, month and/or issue required.

Binders for PE are available from the same address as back numbers at £5.50 each to UK or overseas addresses, including postage, packing and VAT.



SUBSCRIPTIONS

Copies of Practical Electronics are available by post, inland for £13, overseas for £15 per 12 issues, from: Practical Electronics, Subscription Department, IPC Magazines Ltd., Room 2816, King's Reach Tower, Stamford Street, London SE1 9LS. Cheques, postal orders and international money orders should be made payable to IPC Magazines Limited. Payment for subscriptions can also be made using a credit card.

Phone:
Editorial Poole (0202) 671191

We regret that lengthy technical enquiries cannot be answered over the telephone.

Items mentioned are available through normal retail outlets, unless otherwise specified. Prices correct at time of going to press.

NEWS &

MULTIMETER MELL

The choice of multimeters presently available to the electronics industry is indeed comprehensive, as any engineer will testify. For the home constructor, however, this bewildering field can often seem daunting when the purchase of a new or replacement instrument is the order of the day.

Two fully autoranging $3\frac{1}{2}$ digit multimeters have been added to the Beckman Industrial Circuitmate series, the hand-held DM77 and the DM73 probe meter, the latter being one of the smallest meters in the world.

Operation is extremely simple, the only action required, after switching on, being to select the required function (with a rotary switch on the DM77 and a sliding switch on

the DM73). The instrument then automatically selects the range that provides the best resolution, the chosen function being shown on the display. They are therefore ideal instruments for applications where the magnitude of the input signal is unknown or uncertain.

The DM77 has five d.c. and four a.c. voltage ranges (to 1000V and 600V respectively), two a.c. and d.c. current ranges of 200mA and 10A and five resistance ranges of 200ohm to 2megohm. Resistance can be measured with low power for use inside electronic circuits, or high power for measurements out-of-circuit or inside electrical circuits. A buzzer is incorporated for continuity testing and circuit tracing. The DM77 costs circa £52 inc. VAT.

The DM73 is ideal for voltage and resistance measurements in hard-to-reach locations. It has four a.c. and d.c. voltage ranges from 2V to 500V, four resistance ranges from 2Kohm to 2megohm and a buzzer for continuity testing and circuit tracing. A 'display-hold' button facilitates measurements in confined spaces, allowing the display to be read after the probes have been removed from the circuit. The DM73 is priced at circa £46 inc. VAT. For your local stockist ring Beckman on 021-742 7761.



WATFORD MOVE ON UP

In the twelve years since starting business Watford Electronics have come a long way. Now firmly ensconced in their new 9,200 sq ft premises, they also topped the £5m turnover figure last year.

The new premises are owned by Watford and have been designed especially to meet their needs, including a well equipped penthouse flat for the MD—so there is no way he will be any less involved in the continuing development of his company. The extra space gives Watford improved storage, packing and administration areas. Customer facilities now include a car park in front of the building and a very pleasant spacious service and demonstration area.



Watford stock a very large range of general components and i.c.s and have more recently gained a strong reputation for their excellent range of BBC Micro peripherals and their aggressive pricing of BBC Micros.

SPECIAL AGENT FOUND

It's a hard, amorphous brittle substance, a bad conductor of electricity, usually transparent. It's made by fusing together one or more of the oxides of silicon, boron or phosphorous with certain basic oxides (e.g. sodium, magnesium, calcium or potassium) it is then cooled rapidly, to prevent crystallisation; yes, you've guessed it—glass.

Besides its more obvious uses this multipur-



pose material is an excellent cleaning agent. The abrasive properties of the ends of a tightly packed bundle of glass fibre strands are surprising; a London company has now produced a propelling pencil type tool that concentrates the ends of such a bundle for localised cleaning jobs.

The most obvious uses in our field of course are for the cleaning of electrical contacts as a pre-soldering treatment etc. Awkward and inaccessible places can also be dealt with. The length of protruding fibre can be altered to increase or decrease abrasive power.

The Speedplate pencil is supplied with two replacement fibre bundles and retails for circa £1.75 from High Street d.i.y. and motor accessory shops. Further details from, Gunsons Colorplugs Ltd., 40 Warton Road, London E15 2JU. (01-555 7421).

BBC Video Package

Crofton Electronics has specialised in video engineering now for some 16 years and their product range covers everything from cameras, leads and lenses to monitors, software and complete surveillance systems.

They are presently offering an impressive video package for the BBC micro. The offer comprises a video digitiser, a video camera (16mm lens), a processing ROM and a printer dump routine on the disc—of your choice. The package costs £460 inc. VAT and p&p.

Limited space here will not allow a detailed appraisal of this equipment—full details, however, can be obtained from Crofton Electronics, 35 Grosvenor Road, Twickenham, Middlesex TW1 4AD. (01-891 1923).

MARKET PLACE

Automatic Stripper

B&R Electrical Products Ltd. have introduced a high-quality, self-adjusting wire stripper/cutter (Model TC 1017).

The tool operates in one continuous action by gripping the insulating material in its metal jaws, simultaneously cutting through it and removing the insulation by the sliding action of the blades. Moulded into the jaws of the tool are graduations in millimetres and inches to assist measurement of the length of insulation to be stripped.

The new tool is robustly constructed and self-adjusts during operation to enable fast and accurate stripping of insulation from most types of insulated wire (solid or stranded) with outside diameters from 0.5 to 5mm, without damaging the wire. *This product represents very good value especially as the manufacturers have arranged a special price of £4.99 inc. VAT and p&p for PE readers.* Available from Featmarks Ltd., PO Box 16F, Chessington, Surrey KT9 2DA (01-391 0485).



WHAT'S THAT NUMBER?



An interesting addition to the incredible range of multi-purpose digital wristwear is now available from Casio.

Outwardly the Data Bank 500 is a conventional wristwatch, yet it boasts a singularly useful memory facility. Namely that it can memorise up to 50 sets of six letters and 12 figures which can be recalled by the user at any time.

Besides the obvious—telephone numbers, bank account codes, anniversaries, etc., the Data Bank 500 lends itself to more bizarre recall work.

Personal or secret information might feasibly be fed into this 'timepiece', the depth of which could arguably be weighed against the fear of losing it.

MODEL MAN

It's not often we get a chance to combine work with leisure, but Martin Sims, a research engineer with Thorn/EMI at Wells, seems to have done just that. Both he and his 1/7th scale helicopter have been instrumental in solving radar calibration problems at the RN's Frazer gunnery range at Portsmouth.

As can be seen from the picture, the model was used to support a trihedral reflector which was suspended in the air over an RSRE experimental I-band radar system. The reflector appeared to the radar as a 10-metre diameter target. Accurate calibration depended upon maintaining the 'target' at a constant height of 80 metres at a range of 1km, for four minutes.

The helicopter-borne reflector provided an extremely effective low cost solution to the problem of radar 'multipath' or spurious reflections from land or water lying on the range which had previously caused problems.



Countdown ...

Please check dates before setting out, as we cannot guarantee the accuracy of the information presented below. Note: some exhibitions may be trade only. If you are organising any electrical/electronics, radio or scientific event, big or small, we shall be glad to include it here. Address details to Mike Abbott.

IFSSSEC (Fire/Security) April 15-19. Earls Court, London S
 The Northern Computer Show April 16-18. Belle Vue, Manchester K2
 Cast (Cable & Satellite) April 16-18. NEC B/ham F5
 Communications April 23-25. Olympia I
 Photoworld April 23-May 6. Earls Court I
 CAD April 26-28. Metropole, Brighton K2
 British Electronics Week (includes: All Electronics, Circuit Technology & Fibre Optics) April 30-May 2. Olympia E
 Custom Electronics & Design Techniques April 30-May 2 E
 Field Service & Repairs April 30-May 2. Olympia 2 E
 Apple May 9-11, Novotel, London L
 Automan (manufacturing) May. NEC T1
 Electron & BBC May 9-12. New Horticultural Hall, London L

IBM Computer User May 14-16. NEC B/ham O
 Business Telecom May 21-23. Barbican, London O
 CETEX (Consumer Electronics Trade) May 26-29. Earls Court M
 Scotalex June 4-6. Royal Highland Soc., Exhibition Hall, Ingliston, Edinburgh A1
 Software June 4-6. Earls Court, London K2
 The Computer Fair June 13-16. Earls Court K2
 Networks June 25-27. Wembley Conf. Cntr. O
 Cable July 9-11. Metropole, Brighton O
 Personal Computer World Show Sept. 18-22. Olympia 2 M
 Electron & BBC User Sept. 27-29. UMIST, Manchester L
 Electron & BBC User Nov. 14-17. New Horticultural Hall, London L

A1 Inst. Electronics ☎ 0706 43661
 E Evan Steadman ☎ 0799 26699
 F5 ☎ 01-487 4397
 I ITF ☎ 021-705 6707
 K2 Reed Exhibitions, Surrey Ho., 1 Throwley Way, Sutton, Surrey.
 L Database ☎ 061-429 8157
 M Montbuild ☎ 01-486 1951
 O Online ☎ 01-868 4466
 S ☎ 01-387 5050
 T1 Cahners ☎ 0483 38085

AMSTRAD SYNTHESISER INTERFACE

R. A. PENFOLD



THE Amstrad CPC464 computer is a highly versatile machine which is well suited to many applications, including those associated with user add-ons. The interface which is described in this article, together with the correct software, enables the CPC464 to be utilized as a sequencer for a synthesiser which has the standard five volt gate/trigger pulse input and one volt per octave control voltage input. The note is programmable over more than five octaves (including all semitones), and the gate time, plus note duration are also programmable.

With its genuine 64K of RAM a large number of notes can be accommodated. In fact the program enables up to one thousand notes to be entered, and with a slight modification it could probably be made to take sequences several times longer than this. The program includes editing facilities, plus the ability to save sequences on tape and reload them when required.

SYSTEM OPERATION

Driving the gate or trigger input of most synthesisers is perfectly straightforward since all that is needed is a signal at standard TTL levels. A single bit digital output is therefore all that is required to drive this input. Driving the control voltage input is also fairly straightforward for a synthesiser which has standard one volt per octave (logarithmic) input.

With this type of synthesiser the control voltage from the keyboard is provided by a potential divider which has a series of equal value resistors. It thus provides a series of output voltages with an equal step size from one note to the next. It is quite easy to simulate this with a computer, and all that is required is a normal (linear) digital to analogue converter. With this type of converter, if writing '1' to the circuit gave an output voltage of (say) 10 millivolts, then '2' would give 20 millivolts, '3' would give 30 millivolts, and so on. The keyboard of a synthesiser gives increments of about 83 millivolts, and it is just a matter of scaling the output of the digital to analogue converter to precisely match this.

Note that some older synthesisers have a linear control voltage characteristic which, paradoxically, has a non-equal increment from one note to the next, but a linear relationship between the control voltage and the output frequency. Instruments of this type cannot be used with the interface featured in this article, and can not easily be interfaced to a computer.

The block diagram of Fig. 1 shows the general arrangement used in this interface. An address decoder is used to activate a single bit data latch when data is written to a suitable address, and this latch provides the gate or trigger

pulse signal. This output can be placed high or low, as desired, under program control. The address decoder also activates a six bit data latch which is used to drive the digital to analogue converter. The converter is in fact an ordinary eight bit type, but in this application only six bits are normally used as this is sufficient to give a range of 63 notes, which is about the limit for most synthesisers. The two least significant inputs of the converter are simply tied to the negative supply rail.

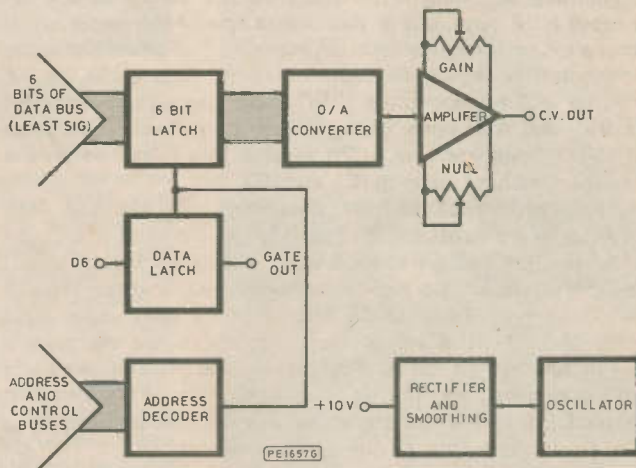

Fig. 1. Block diagram of the Amstrad Sequencer

The converter has an output that increments in units of nominally 10 millivolts, but as the two least significant bits are not used here this is boosted to 40 millivolts. This is not sufficient to drive the control voltage input of a synthesiser, and an amplifier is used to boost the output voltage by a factor of about two times.

A gain control enables the output voltage increment to be trimmed to exactly the correct figure. An offset null control enables any d.c. offsets in the system to be trimmed out so that good pitch accuracy is obtained at the low frequency end of the range.

The circuit is powered from the five volts output of the CPC464, and this is the only supply output which the machine provides. This is inadequate to drive the amplifier stage which must provide a maximum output voltage of just over five volts. This problem is overcome by rectifying and smoothing the output of an oscillator to produce a supply potential of about ten volts for the amplifier stage.

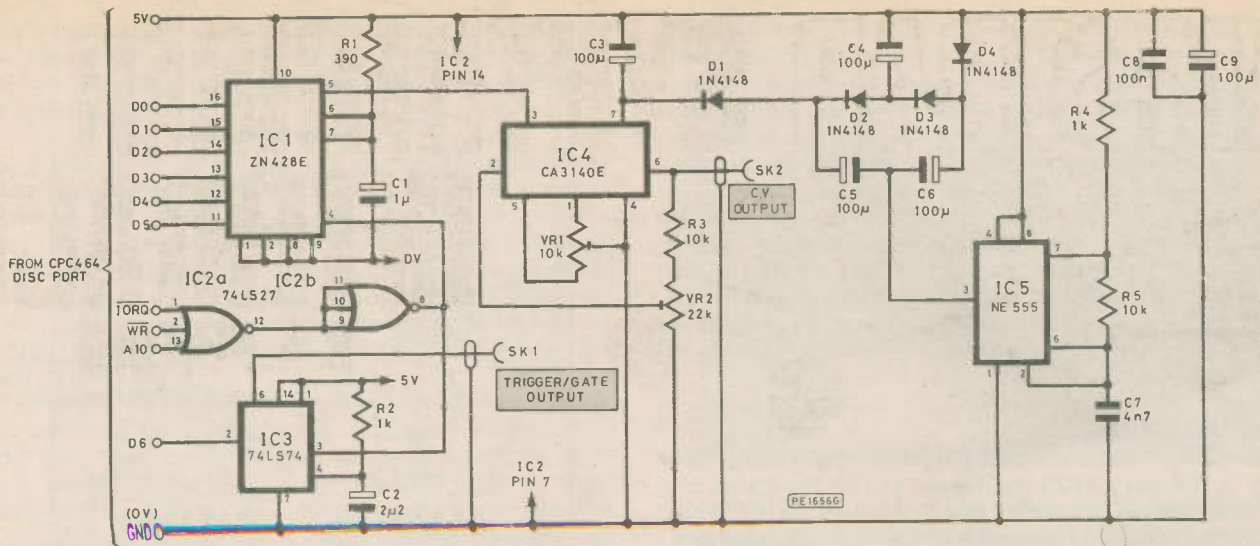

Fig. 2. Complete circuit diagram of the Amstrad Sequencer

CIRCUIT OPERATION

The full circuit diagram of the interface appears in Fig. 2. The unit connects to the floppy disc port of the computer which is really a general purpose port which makes available the full address, data, and control buses of the computer, as well as a number of other useful lines.

Address decoding is provided by IC2 which is a triple 3-input NOR gate, but in this circuit one of the gates is left unused, and the three inputs of one of the other gates are connected together so that this gate acts as a simple inverter. IC2a decodes the $\overline{\text{TORQ}}$ (input/output request), $\overline{\text{WR}}$ (write), and A10 lines, giving a high output when all three of these lines are low. IC2b inverts this signal to give a negative latching pulse to IC1 and IC3.

This method of address decoding may seem a little strange by conventional Z80 standards, with just one of the address lines being decoded with the relevant control bus lines, and one of the eight most significant address lines at that. However, the CPC464 does not have the conventional form of Z80 input/output mapping where the eight least significant lines of the address bus are decoded to give up to 256 addresses, and the eight most significant lines are left unused. Instead, input/output circuits are activated by taking the appropriate one of the eight most significant address lines low, while the eight least significant address lines are available for use if an input output device requires several addresses. This is similar although not identical to the system used in the Sinclair Spectrum computer.

Address line A10 is available for use with external add-ons, and it is therefore this line going low that is used to activate the sequencer interface. Of course, with only one address line being decoded there are numerous addresses that can be used to operate the interface, but in practice it is advisable to only use &F800 as with the only exception of A10 this leaves all the address lines high and will not produce spurious operations of internal circuits of the computer.

IC3 is a dual D-type flip-flop, but only one section is utilized here; it is used as a data latch with the latching pulse from the decoder circuit applied to the "clock pulse" input. The gate/trigger pulse is obtained from the $\overline{\text{Q}}$ output of the flip/flop.

The digital to analogue converter, IC1, is a Ferranti ZN428E. This is a conventional type having an integral 2.55V precision voltage source, eight electronic switches, and an R-2R resistor network. The voltage reference re-

quires discrete load resistor R1 and decoupling capacitor C1. The output from this stage is coupled to the input of an operational amplifier (IC4) which is used as a non-inverting amplifier. R3 and VR2 form the negative feedback network which set the closed loop voltage gain of the circuit, and VR2 is adjusted to give the correct level of voltage gain. VR1 is the offset null control for IC4.

COMPONENTS ...

Resistors

R1	390
R2,R4	1k (2 off)
R3,R5	10k (2 off)
All fixed resistors are 0.25W 5% carbon	

Potentiometers

VR1	10k 0.1W horizontal preset
VR2	22k 0.1W horizontal preset

Capacitors

C1	1 μ 63V radial elect
C2	2 μ 2 63V radial elect
C3-C6, C9	100 μ 10V radial elect (5 off)
C7	4n7 carbonate
C8	100n ceramic

Semiconductors

D1-D4	1N4148 (4 off)
IC1	ZN428E
IC2	74LS27
IC3	74LS74
IC4	CA3140E
IC5	NE555

Constructor's Note

A complete listing of the sequencer program is available for £1 inc. P&P from our editorial offices.

Miscellaneous

SK1, SK2 standard jack sockets (2 off)
 Printed circuit board PE 505-01
 Case 133 x 102 x 38mm
 2 x 25 way 0.1 inch pitch edge connector
 16 pin d.i.l. i.c. holder
 14 pin d.i.l. i.c. holders (2 off)
 8 pin d.i.l. i.c. holders (2 off)
 Ribbon cable, wire, connecting leads, etc.

IC4 is a CA3140E, a device which has a Class A output stage that enables output voltages right down to the 0V rail to be produced. This obviates the need for a negative supply rail. IC5 is a 555 timer device which operates in the standard astable mode. This is the oscillator which is used to provide the boosted positive supply for IC4. Its output is rectified and smoothed by D3, D4, and C6, and also by D1, D2, and C3. The resultant positive outputs are effectively connected in series together with the 5V supply so as to give a voltage tripling action. However, in practice losses through the diodes and the output stage of IC5 result in a loaded supply potential of only about 10V or so, but this is still more than adequate to permit IC4 to provide a peak output voltage of about five to six volts.

CONSTRUCTION

A suitable printed circuit design for this project is provided in Fig. 3. IC4 has a MOS input stage and an integrated circuit holder should be used for this component. As IC1 is not one of the cheapest of devices it is also advisable to use a socket for this component. Be careful to fit this device the right way round—it has the opposite orientation to the other integrated circuits. Fit Veropins at the points where the board will be connected to SK1 and SK2. Do not overlook the two link wires.

The board is connected to the floppy disc port of the computer by way of a piece of 13 way ribbon cable about 0.5 to 1 metre long and terminated in a 2 by 25 way 0.1 inch pitch female edge connector. A connector having a suitable polarising key is unlikely to be available, and care to fit the connector the right way round must be taken. It is advisable to clearly mark the top and bottom edges of the connector as such, or with a little ingenuity it might be possible to add a polarising key to the connector. Fig. 4 gives connection details for the edge connector.

An aluminium box having approximate outside dimensions of 133 by 102 by 38mm is used as the housing for the prototype, but any case of about this size should be satisfactory. SK1 and SK2 are standard jack sockets which match the connectors used on the vast majority of synthesisers, and they are mounted on the front panel.

The printed circuit board is mounted on any convenient area of the base panel of the case using 6BA or M3 fixings. If the case is a metal type it is obviously essential to use spacers to prevent the connections on the underside of the board from being short circuited through the case, and even if a non-metal case is used it is still advantageous to use spacers. This avoids any distortion of the board and possible damage when the mounting nuts are tightened.

Some means of taking the ribbon cable through the case must be found, and it may be possible to simply take it through the small gap between the top and base sections of the case. If this is not possible a suitable slit must be cut or filed in the rear panel of the case. To complete the unit the connections from the printed circuit board to SK1 and SK2 are added.

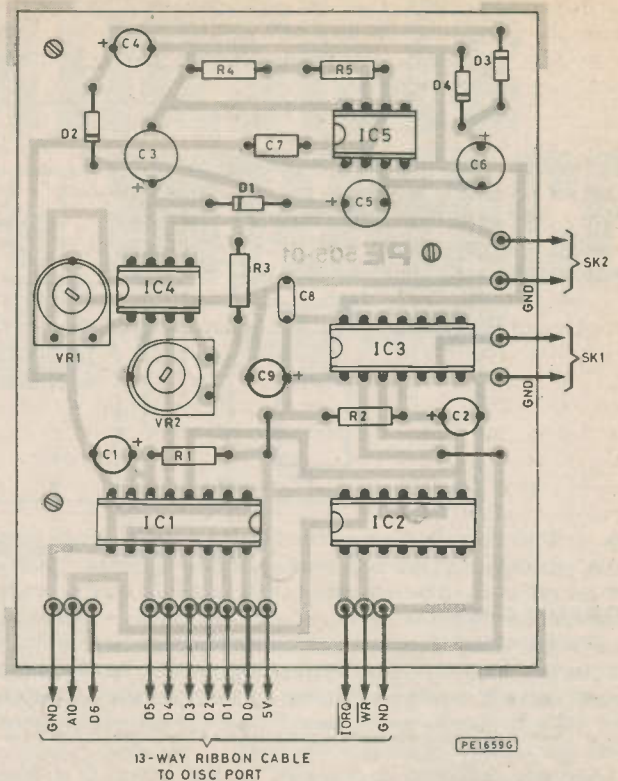

Fig. 3. P.c.b. design and component layout of the Amstrad Sequencer

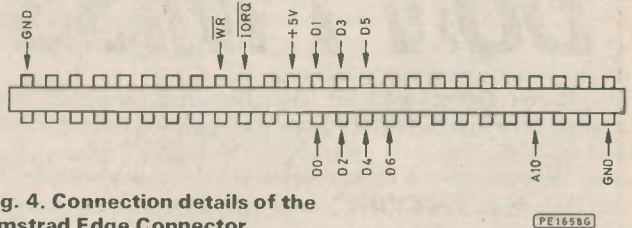

Fig. 4. Connection details of the Amstrad Edge Connector

ADJUSTMENT AND USE

Start with VR1 and VR2 at a roughly central setting. Connect the unit to the computer prior to switching on. The computer should display the usual ready message etc.—switch off at once and recheck the wiring if it does not. As a quick check of the unit the command:—

OUT &F800,0

should set the gate/trigger output high and the control voltage output at virtually zero. The command:—

OUT &F800,127

should set the gate/trigger output low, and the control voltage output at something in the region of 5V.

In order to set VR1 and VR2 at the correct settings, first set the control voltage output to give the lowest note using the command:—

OUT &F800,1

When using the interface remember that a value of '1' gives the lowest note, and the a value of '0' is not used as a note value. Connect SK1 and SK2 to the appropriate inputs of the synthesiser using standard jack leads. With most synthesisers it is necessary to have one or more of the controls in the right position before the external inputs will function properly, and the manual should give details of the correct control settings if you are in any doubt about this point.

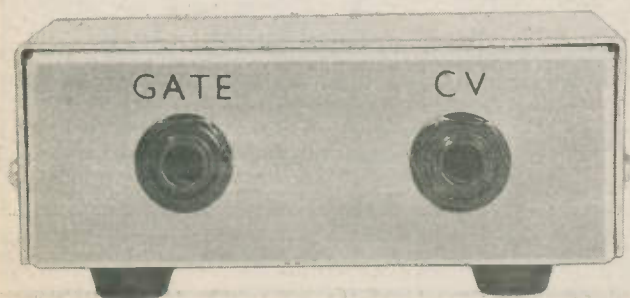

STEREO

NOISE GATE & VCA

JOHN M.H. BECKER

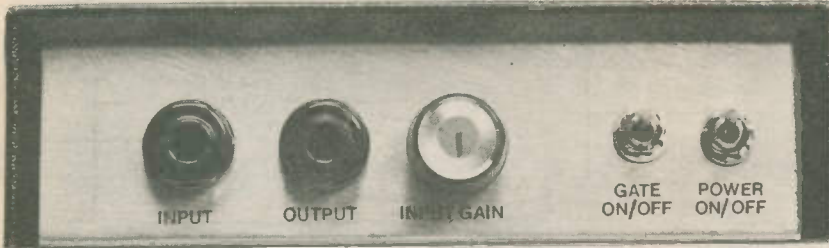

BACKGROUND noise generated by electronic circuits will often be disguised by the presence of a full strength audio signal. When this ceases the background may then become intrusive. Turning down a volume control is the usual remedy, but the electronically controlled noise gate described here can automatically perform a similar function. Additionally, as the signal level falls below a predetermined point, it increases the expansion ratio and progressively reduces the noise-containing lower levels faster than the higher signal levels. It has been designed with home recording studios and performing musicians in mind, and can be used with either stereo or mono high output-level equipment. It also features override switching, and a voltage controlled amplifier as a balanced input level and gain stage.

Fig. 1 shows a block diagram, and Fig. 2 shows the full circuit. This consists of three twinned stages—Voltage Controlled Inputs IC1, Level Detection Stages IC2a, and Noise Gates IC3. The description covers only one channel, the other performs identical functions and the equivalent components will be obvious from Fig. 2.

VOLTAGE CONTROLLED INPUT

IC1a is a transconductance amplifier where the gain is determined by the current present at its control node and the value of R4. The input signal level is first attenuated to 1/100th by R1 and R2 so reducing overload distortion through IC1a at the permitted peak input strengths up to about 8 volts pk-pk. Input levels between this and 16V pk-pk will cause triangular waveforms to be rounded off a bit. The current at the control node is derived from VR1 via R30. With the wiper of VR1 at the negative end the current flowing at the control node is negligible so the VCA does not conduct and the signal output level is nil. As VR1 is rotated to the positive end the current increases and with it the gain. At about 180° rotation the gain for large signals

produces an output at R4 that matches the original input level. At full rotation the output is about 6 volts for a 1 volt input level, allowing the unit to act as a slight overall gain stage. As the control node of IC1a is linked directly to that of IC1c both VCAs track in unison. The outputs from the buffer IC1b should not exceed 6V pk-pk to avoid overloading IC3.

LEVEL DETECTION

From IC1b the signal is routed in two directions, to the noise gate input and to the level detection stage IC2a. Here the gain is set by R6 and R8, with diodes D1 and D2 clipping and limiting the maximum squarewave output to 1.2V pk-to-pk for signals greater than about 0.5V pk-pk. This forms the controlling signal passed to the rectifier and throughout control stage within the noise gate.

NOISE GATE

The signal from IC1b via C3 is allowed to pass through the gate at a gain level and expansion ratio depending on the voltage presented to its rectifier stage. These remain constant while the control voltage is at the maximum level. When the signal level drops sufficiently for the control voltage to fall the gate commences an expansion, governed by R10, that increases as its input nears -60dB. This effectively results in the lower level background noise receiving greater attenuation than the main signal until the gain drops to zero at -60dB. The rate at which the attack and decay occurs is controlled by C6 the value of which has been selected to give a reasonable trade-off between the need for a sharp attack so that opening transients will not be restrained, and a slow decay so that the background noise does not appear to cut in and out sharply. Overriding of the control voltage from IC2a is performed by S1 which switches in a constant voltage of the correct level as set by VR4. R9 is a buffer resistor and C15 reduces the ripple voltage. The gain of the signal passing through is also controlled by the value of R12. This has been chosen to give a suitable level restoration to compensate for the insertion of R9 into the control voltage path. The maximum output level is about 6V pk-pk. Greater gain could be given, but might result in distortion at higher signal strengths. Normal waveform distortion through the gate is trimmed out by the bias from VR2. The output is overload protected.

POWER SUPPLY

Two nine volt batteries can power the unit with a current drain of about 10mA. The voltage supplied must not exceed +9V/0V/-9V, but the author's unit was found to operate satisfactorily down to only +5V/0V/-5V with the presets and signal levels adjusted accordingly.

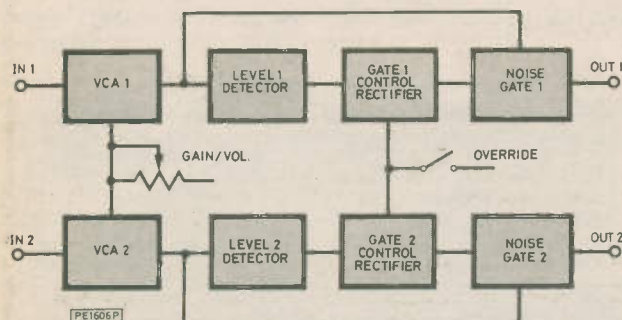

Fig. 1. Block diagram

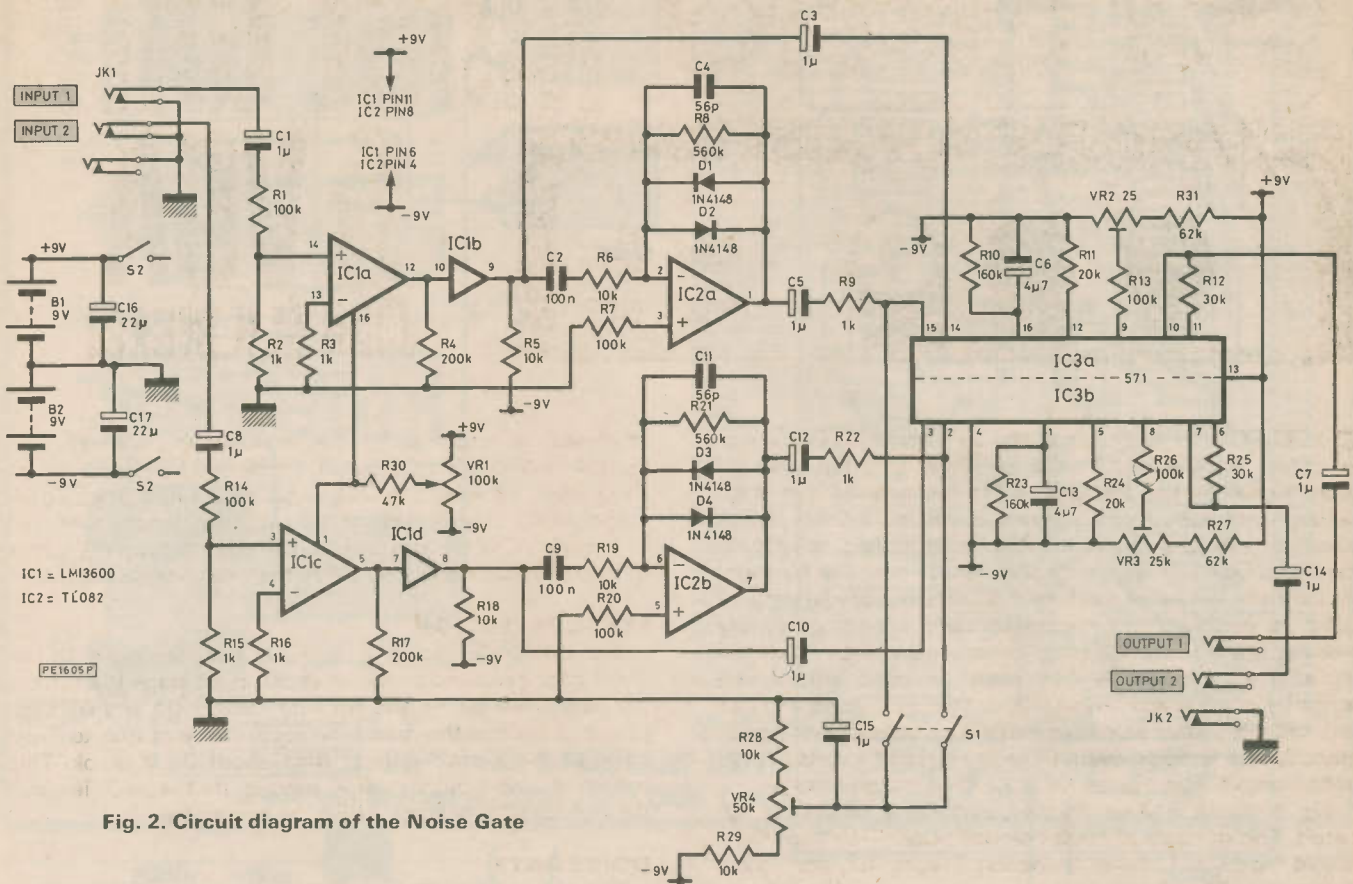

Fig. 2. Circuit diagram of the Noise Gate

ASSEMBLY

Neatly mount all the components flush with the printed circuit board, taking care that the capacitors and diodes are correctly polarised. It also helps with future checking if the identity markings are clearly visible, and resistor colour codes consistently orientated. Use resistor off-cut wires for the short p.c.b. links. The i.c.s are not MOS devices, but still

should only be inserted into their sockets, the correct way round, after soldering has been completed. Do not forget to thoroughly check the soldering before applying power. Keep control wiring neat and short, but long enough so that the p.c.b. can be inverted for examination of the track side. Screened leads were not found to be necessary with this battery operated unit, though it is recommended that the

COMPONENTS . . .

Resistors

R1, R7, R13, R14, R20, R26	100k (6 off)
R2, R3, R9, R15, R16, R22	1k (6 off)
R4, R17	200k (2 off)
R5, R6, R18, R19, R28, R29	10k (6 off)
R8, R21	560k (2 off)
R10, R23	160k (2 off)
R11, R24	20k (2 off)
R12, R25	30k (2 off)
R27, R31	62k (2 off)
R30	47k

All resistors 1/4W 5% carbon film

Capacitors

C1, C3, C5, C7, C8, C10, C12, C14, C15	1µ 63V elect (9 off)
C2, C9	100n (2 off)
C4, C11	56p (2 off) polystyrene
C6, C13	4µ7 63V elect (2 off)
C16, C17	22µ 10V elect (2 off)

Semiconductors

D1, D2, D3, D4	1N4148 (4 off)
IC1	LM13600
IC2	TL082
IC3	571

Potentiometers

VR1	100k log
VR2, VR3	25k skeleton preset (2 off)
VR4	50k skeleton preset

Miscellaneous

- PP3 battery clip (2 off)
- P.c.b. clips
- P.c.b.
- Round knob
- 8-pin d.i.l. socket
- 16-pin d.i.l. socket (2 off)
- Stereo jack socket (2 off)
- Switch d.p.d.t. (2 off)

Constructor's Note

A complete kit of parts is available from **Phonsonics** (£31.60 including p&p and VAT), 8 Finucane Drive, Orpington, Kent BR5 4ED.

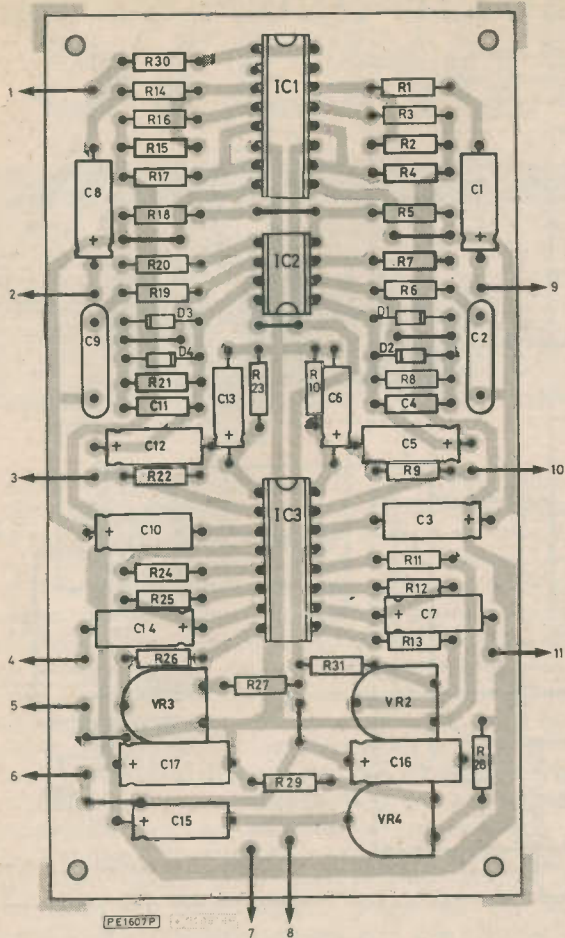

Fig. 3. Component layout of the p.c.b.

box is connected to the 0V line. Scraping and soldering to the metal body of VR1 should be adequate. Upon completion, panel legends can be applied using dymo tape, leterset or similar.

SETTING UP

Set VR1 to 180°, VR2/3 midway, S1 off. Apply a high level signal on the input, preferably over 1.2V pk-pk, but not over 6V pk-pk unless VR1 is reduced accordingly. Check that the signal reaches the main amplifier into which the unit is plugged. If it does not check the joins and that the jack sockets are wired to the correct tags! Assuming success adjust VR2 and VR3 until the minimum distortion is apparent. If an oscilloscope and signal generator are used, this is most evident with a triangle wave between about 1kHz and 3kHz, monitoring at IC3 pins 7 and 10. If monitoring by ear is the only available means each channel should be checked with the other silent. If adjustment differences are not noticeable leave VR2 and VR3 midway and ignore. Next, still applying a constant level signal between the above limits, repeatedly switch S1 on and off while adjusting VR4 until the levels of the auto-gate and override modes are identical. With low level signals, a difference is bound to be obvious because the auto-gate control voltage will be less than maximum. Stop the input test signal, leaving only the background noise from the same source to come in. Switching S1 on and off, the muting effect of the circuit will be apparent.

USE

The unit can be of use with most high level output sources having an intrusive quiescent background noise, such as

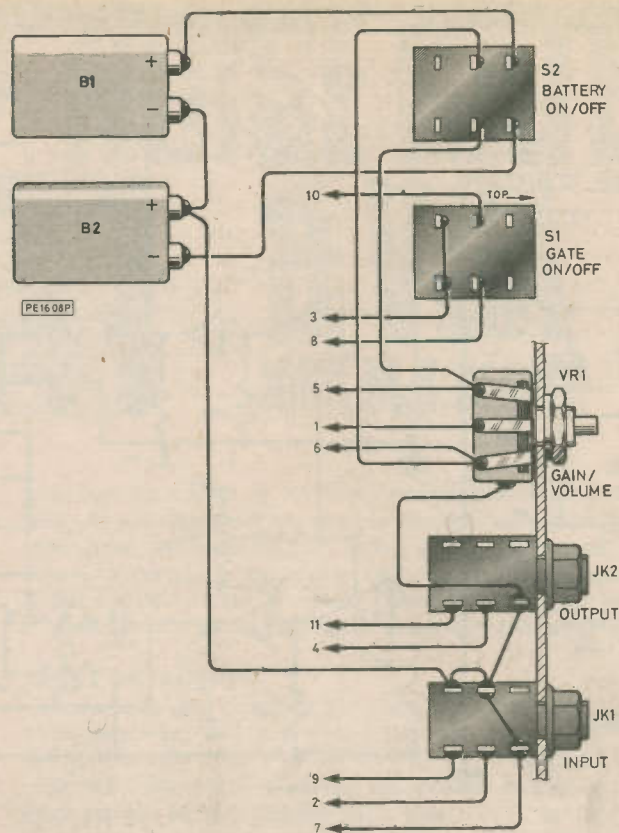
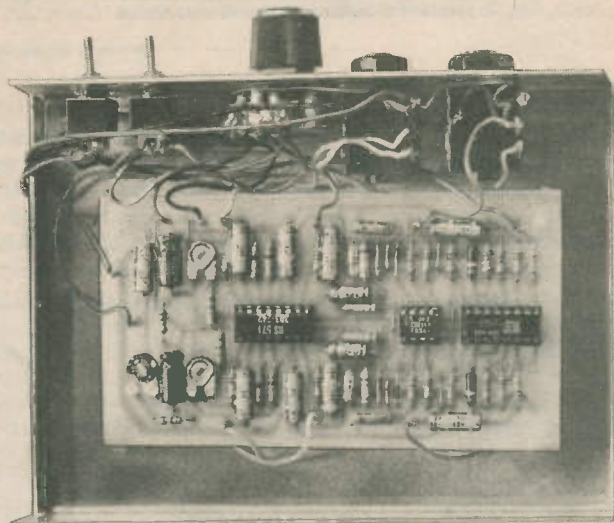

Fig. 4. Wiring diagram



Internal view

tape recorders, musical instruments, effects or multi-mix units, and where the basic signal strength is fairly constant. For speech tracks it should be used with caution for if the background hiss is heavy and the speech rate inconsistent, the repeated muting can be more distracting than the noise level. The same applies to music having a wide dynamic range, where the volume may intentionally drop to a low level, but one that may be below the noise gate threshold. In such instances, the input level should be optimised at source, perhaps through a compressor. Remember that the input VCA will contribute slightly to the background and using it for gain correction greater than unity will also affect the noise trigger level. The frequency range is from about 10Hz to in excess of 30kHz before serious signal deterioration results. ★

P.E. AUDIO EFFECTS AND OTHER SUPER SOUND KITS!

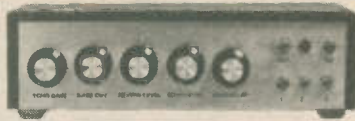

P.E. MONO-STEREO ECHO-REVERB (SEP84) 200ms echo, lengthy reverb, multi-tracking kit as published - BLK box: SET 218 £55.66



P.E. FILTER-SHIFT PHASER (OCT84). Enhanced Phasing with modulated filter shifting. Kit as published - BLK box: SET 226 £39.13



P.E. RING MODULATOR (NOV84). With multi-waveform VCO, Noise Gate & Auto-level Control. Kit as published - BLK box: SET 231 £39.99



P.E. MONO-STEREO CHORUS FLANGER (JAN85). Superb dual mode music enhancement. Kit as published - BLK box: SET 235 £55.66

BLK BOX - steel & aluminium, black plastic finish. STD BOX - plain aluminium, lipped lid. SET codes include PCBs, parts, instructions, boxes, wire, solder. More details & kits in catalogue - send S.A.E. (Overseas £1 or 5 IRC's).

	CODE	STD BOX	BLK BOX
BASS BOOST: Increases volume of lower octaves	SET 138B	£8.46	£11.46
BLOW BOX: Voice operated VCF & VCA for fascinating effects	SET 214	£24.33	£28.33
CHORUS (SIMPLE): Multiplied solo enhancement	SET 162	£31.40	£34.90
COMPRESSOR: Limits & levels maximum signal strength	SET 133	£10.86	£13.86
ENVELOPE SHAPER: Note triggered ADSR unit with VCA	SET 174	£17.15	£20.65
EQUALISER: Variable combinations of Low, Mid, Top & Notch	SET 217	£22.33	£25.83
EQUALISER: 10 Channels fully variable	SET 134	£37.83	£41.83
FADER: Voice operated with 5 response controls	SET 167	£14.21	£17.21
FLANGER (SIMPLE): Fascinating phased resonance effects	SET 153	£22.74	£26.24
FREQUENCY CHANGER: Tunable note & waveform modifier	SET 172	£34.46	£37.96
FREQUENCY DOUBLER: Guitar octave raiser & tone changer	SET 98	£9.80	£12.80
FUNKY-WOBULO: Modulates a singing voice	SET 149	£12.40	£15.40
FUZZ: Smooth distortion, retains attack & decay	SET 91	£10.57	£13.57
GUITAR OVERDRIVE: Heavy fuzz with selectable qualities	SET 56	£19.73	£23.23
GUITAR (SIMPLE): Extends note decay time, with noise gate	SET 222	£22.81	£25.31
GUITAR TO SYNTH INTERFACE: With voltage & trig outputs	SET 173	£32.87	£36.37
HAND CLAPPER: Auto & manual variable clap effects	SET 197	£22.69	£25.69
HEADPHONE AMP: 2 watts into phones or speaker, variable	SET 156M	£12.03	£15.53
JABBERVOX: Voice disguiser with reverb & tremolo	SET 150	£28.84	£32.34
METRONOME: With audio output & visual beat & downbeat	SET 143	£13.81	£16.81
MIC PRE-AMP: Variable gain & switched tone response	SET 147	£7.13	£10.13
MIXERS: Several in catalogue			
MOCK STEREO: Splits mono signal into stereo simulation	SET 213	£19.87	£23.37
MULTIPROCESSOR: Flng, Rvb, Faze, Fuzz, Wah, Trem, Vib	SET 189	£57.14	£61.14
MUSIC MODULO: 8 variable tremolo & wah guitar effects	SET 196	£18.79	£21.79
MUSICAL CALL SIGN: Programmed call sign generator	SET 121	£12.91	£16.41
NOISE GATE: Reduces tape & system noise	SET 145	£9.97	£12.97
PHASER (SIMPLE): Auto & manual rate & depth controls	SET 164	£18.40	£21.90
REVERB: (SIMPLE) Mono/stereo, variable depth & delay	SET 203	£25.54	£29.54
RHYTHM GENERATOR: Computer driven, 9 drum effects	SET 185	£30.64	£34.64
RHYTHM GENERATOR: 15 pre-programmed rhythms, 9 effects	SET 770	£35.64	£39.14
ROBOVOX: Versatile robot type voice modifier	SET 165	£21.03	£24.53
SPEECH PROCESSOR: Clearer speech and level control	SET 110	£9.68	£12.68
STORMS EFFECTS: Auto & manual wind, rain, & surf effects	SET 154	£15.86	£19.36
SWEEP GENERATOR: Auto sine wave 20Hz-15KHz, variable	SET 169	£16.41	£19.91
TOM-TOM SYNTH: Sound triggered, multivariable	SET 190	£15.05	£18.05
TONE CONTROL: Bass, mid, treble, gain & cut	SET 139	£13.17	£16.67
TREBLE BOOST: Increases volume of upper octaves	SET 138T	£8.13	£11.13
TREMULO: Mono variable rate & depth modulation	SET 136	£9.71	£12.71
VOLTAGE CONTROLLED FILTER: 12dB, variable modes	SET 178	£17.02	£20.52
VOCODER: Modular vocoder, 7 chans, extendable	SET 152	£64.31	£68.31
VODALEK: Robot type voice modulator	SET 155	£12.44	£15.44
VOICE OP SWITCH: Variable sensitivity & delay	SET 123L	£13.41	£16.41
WAH-WAH: Auto, manual & note triggered	SET 140	£17.26	£20.76

MAIL ORDER: Add 15% VAT & £1 P&P to all orders (overseas details in cat). Payment CWO, CHO, PO, ACCESS, VISA. Details correct at press, E&OE. Despatch usually 10-14 days.

PHONOSONICS, DEPT PE55, 8 FINUCANE DRIVE, ORPINGTON, KENT, BR5 4ED.

Tel: Orpington 37821 (STD 0689, London 66), Mon-Fri 10-7.

Intruder Alarms and Accessories

A COMPLETE SECURITY SYSTEM FOR ONLY £39.95 + V.A.T.

- Control Unit CA 1250
Enclosure & mechanical fixings HW 1250
Key Switch & 2 keys KS 3901
LED's LED 1
5 1/2" Horn Speaker HS 588
4 high quality surface mounting Magnetic Switches MS 1025

With only a few hours of your time it is possible to assemble and install an effective security system to protect your family and property, at the amazingly low cost of £39.95 + V.A.T. No compromises have been made and no corners have been cut. The outstanding value results from volume production and direct supply. Assembly is straightforward with the detailed instructions provided. When installed you can enjoy the peace of mind that results from a secure home. Should you wish to increase the level of security, the system may be extended at any time with additional magnetic switches, pressure pads or ultrasonic sensors. Don't wait until it's too late - order today.
Order Code: CS 1370

EXTENDED SYSTEM CS 1480 Price £62.50 + V.A.T.

This system contains, in addition to the CS 1370, an ultrasonic detector type US 5063 - its enclosure, an additional horn speaker and a further 2 magnetic switches. This system represents outstanding value for money for the high level of security provided.
Order Code: CS 1480

SELF-CONTAINED ULTRASONIC ALARM UNIT CK 5063

only £37.00 + V.A.T.

- Requires no installation. Easily assembled using our professionally built and tested modules.
- *Adjustable range up to 25ft
 - *Built-in entrance and exit delay
 - *Built-in timed alarm
 - *Key operated switch - Off, Test and Operate
 - *Provision for an extension speaker
 - *Fully self-contained
 - *Uses US 5063, PSL 1865 Key Switch 3901
 - *3" Speaker 3515

Now you can assemble a really effective intruder alarm at this low price using tried and tested Riscomp modules. Supplied with full instructions, the kit contains everything necessary to provide an effective warning system for your house or flat. With a built-in LED indicator and test position the unit is easily set-up requiring no installation. It may simply be placed on a cupboard or desk. Movement within its range will then cause the built-in siren to produce a penetrating 90db of sound or even 110db's with an additional speaker. All parts included and supplied with full instructions for ease of assembly. Size 200 x 180 x 70mm. Order as CK 5063.

RISCOMP LIMITED

Dept PE50
21 Duke Street,
Bucks. Risborough,
Bucks. HP17 0AT
Princes Risborough (084 44) 6326

ALARM CONTROL UNIT CA 1250

Price £19.95 + V.A.T.

- The heart of any alarm system is the control unit. The CA 1250 offers every possible feature that is likely to be required when constructing a system whether a highly sophisticated installation or simply controlling a single magnetic switch on the front door.
- *Built-in electronic siren drives 2 loud speakers
 - *Provides exit and entrance delays together with fixed alarm time
 - *Battery back up with trickle charge facility
 - *Operates with magnetic switches, pressure pads, ultrasonic or I.R. units
 - *Anti tamper and panic facility
 - *Stabilised output voltage
 - *2 operating modes full alarm anti tamper and panic facility
 - *Screw connections for ease of installation
 - *Separate relay contacts for external loads
 - *Test loop facility

HARDWARE KIT HW 1250

only £9.50 + V.A.T.

This attractive case is designed to house the control unit CA 1250, together with the appropriate LED indicators and key switch. Supplied with the necessary mounting pillars and punched front panel, the unit is given a professional appearance by an adhesive self screened label. Size 200 x 180 x 70mm

SIREN & POWER SUPPLY MODULE PSL 1865

only £9.95 + V.A.T.

A complete siren and power supply module which is capable of providing sound levels of 110db's at 2 metres when used with a horn speaker. In addition, the unit provides a stabilised 12V output up to 100mA. A switching relay is also included so that the unit may be used in conjunction with the US 5063 to form a complete alarm.

NEW

TIMER SWITCH & POWER SUPPLY MODULE DP 3570 Price £19.95 + V.A.T.

The DP 3570 consists of an adjustable timer switch and stabilised 12V power supply for use in a wide range of applications including security, lighting control and automatic switching. The timer section of the module provides switching of loads up to 3A for pre set times, the duration of which may be set by the user to between 10 secs and 5 mins. The timed period may be triggered by the opening of a loop or the closing of external contacts. With the timed period commencing instantaneously or delayed to provide a form of entrance delay. The power supply section of the module provides a 12V output of up to 250mA which is sufficient for most applications. The module operates from either 240V ac supply or a 12V battery for which trickle charge facilities are included. Connections to the module are by means of screw terminal connectors with no soldering needed.

For mounting the unit an attractive moulded enclosure is available.

ME 357 only £2.85 + V.A.T.

INFRA-RED SYSTEM IR 1470 only £25.61 + V.A.T.

Consisting of separate transmitter and receiver both of which are housed in attractive moulded cases, the system provides an invisible modulated beam over distances of up to 50ft operating a relay when the beam is broken. Intended for use in security systems, but also ideal for photographic and measurement applications.
Size 80 x 50 x 35mm

DIGITAL ULTRASONIC DETECTOR US 5063

only £13.95 + V.A.T.

- *3 levels of discrimination against false alarms
- *Crystal control for greater stability
- *Adjustable range up to 25ft
- *Built-in delays
- *12V operation

This advanced module uses digital signal processing to provide the highest level of sensitivity whilst discriminating against potential false alarm conditions.

ULTRASONIC MODULE ENCLOSURE

only £2.95 + V.A.T.

Suitable metal enclosure for housing an individual ultrasonic module type US 5063 or US 4012. Supplied with the necessary mounting pillars and screws etc. For US 5063 order: SC 5063, for US 4012 order: SC 4012.

RISCOMP THE SECURITY SPECIALISTS!

Add 15% VAT to all prices
Add 10p post and packing to all orders
Units on demonstration
Shop hours 9.00 to 5.30 p.m.
Closed Wednesday

Saturday 9.00 to 1.00 p.m.
S.A.E. with all enquiries
Order by telephone or post using your credit card

Please allow 7 days for delivery

FULL RANGE OF ACCESSORIES STOCKED SEND SAE FOR DETAILS

AFFORDABLE ACCURACY QUALITY MULTIMETERS FROM ARMON

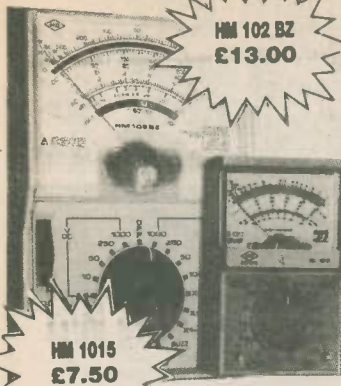

HM 102 BZ
£13.00

ANALOGUE

HM-102BZ
10ADC Range, 20KΩ/VDC, Buzzer, Battery Test Scale £13.00
19 measuring ranges
HM-102R
Low end voltage & current ranges, Jack for Audio o/p Voltages £11.00
20 measuring ranges.
HM-101S
Rugged, Pocket sized meter, for general purpose use £7.50
16 measuring ranges
Battery, Test Leads and Manual included with each model.

HM 101S
£7.50

DIGITAL

HC-6010 0.5% Accuracy, Standard Model £33.50
HC-5010T 0.25% Accuracy, TR Test Facility £39.50
All models have full functions and ranges and feature:

3½ digit 0.5" LED display
Low battery indication
Auto zero & Auto polarity
ABS Plastic Casing & Tilt Stand
DC AC 10amp Range
Overload Protection on all ranges.
Battery, Spare Fuse, Test Leads and Manual

HC 7030

0.1% accuracy
£39.50
push button



HC 5010
0.25% accuracy
rotary

FULL DETAILS ON APPLICATION FROM:-
ARMON ELECTRONICS LTD
DEPT L, HERON HOUSE, 109 WEMBLEY HILL ROAD, WEMBLEY, MIDDLESEX HA9 8AG
TELEPHONE 01-902 4321 TELEX 923985
PLEASE ADD 15% to your order for VAT. P&P Free of charge. Payment by cheque with order
Offer applicable to mainland UK only
Trade enquiries invited Please allow 28 days for delivery

CLEF ELECTRONIC THE CLEF CMS



The FULLY programmable digital synthesiser that you can AFFORD
THE NEW CLEF COMPUTER MUSIC SYSTEM is so user programmable that you need a BBC Micro to run it! 32 harmonically programmable oscillators. 32 programmable envelopes. 5 octave touch sensitive keyboard, up to 4 OSC/ENVS per note. Real time sequencing. Massive potential for future software. Complete system (without BBC Micro) £495 built. Phone or write for details. Modular systems also available.

MUSIC MASTER RHYTHM PROGRAMMABLE DRUMS



As Published in P.E.

Twenty-Four Rhythm programmable Drum Machine with twelve instruments. Eight sections are extended to 24/32 measures for two bar programming. Sequence operation and instrument tone adjust.
COMPLETE KIT £79
STRING ENSEMBLE ROTOR-CHORUS MICROSYNTH P.C.B. & ELECT KITS £86.90
PERCUSSION SYNTH P.C.B. & ELECT KITS £97.90

88/72 NOTE PIANOS SPECIALISTS SINCE 1972

Using Patented electronic technique to give advanced simulation on Piano Key Inertia.

COMPONENT KITS

including Keyboard

88 NOTE £266

72 NOTE £234

The above may also be purchased in four parts.

SQUARE FRONT KEYBOARDS

88 NOTE £60

49 NOTE £29

73 NOTE £50

30 NOTE £19

KEYSWITCH ITEMS ALSO AVAILABLE

ALL PRICES INC. VAT, CARR & TELEPHONE ADVICE. S.A.E. for full Specs & MANF. PRICES. VISA-ACCESS. AMERICAN EXPRESS. Competitive quotes can be given for export, Allow 3-14 days for normal despatch.

CLEF PRODUCTS (ELECTRONICS) LIMITED
(Dept P.E.) 44A BRAMHALL LANE SOUTH BRAMHALL
STOCKPORT CHESHIRE SK7 1AH
TEL 061-439 3297

BAND-BOX PROGRAMMABLE BACKING TRIO

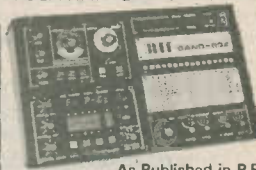

As Published in P.E.

THREE PIECE BACKING BAND
Generates the sounds of three instrumentalists to back Soloists
DRUMS + BASS + KEYBOARDS
Over 3,000 chord changes (60 scores) on 132 different chords - 16 chord sounds. Master Rhythm also required.
FULL KIT £265 BUILT £370

Master Electronics - Microprocessors - Now! The Practical Way!

- Electronics - Microprocessors - Computer Technology is the career and hobby of the future. We can train you at home in a simple, practical and interesting way.
- Recognise and handle all current electronic components and 'chips'.
- Carry out full programme of experimental work on electronic computer circuits including modern digital technology.
- Build an oscilloscope and master circuit diagram.
- Testing and servicing radio - T.V. - hi-fi and all types of electronic/computer/industrial equipment.

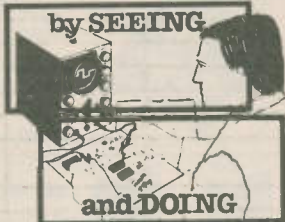

by SEEING

and DOING

New Job? New Career? New Hobby?

SEND THIS COUPON NOW.

FREE! COLOUR BROCHURE

Please send your brochure without any obligation to

OR TELEPHONE US 062 687 2598
OR TELEX 22758 (24 HR SERVICE)



NAME _____ I am interested in _____
ADDRESS _____
 ELECTRONICS
 MICROPROCESSORS
 RADIO AMATEUR LICENCE
 CITY & GUILDS EXAMS
Other Subjects _____

British National Radio & Electronics School P.O. Box 7, Teignmouth, Devon, TQ14 0HS

SAxon MOSFET AMPLIFIERS

UNBEATABLE PRICES!!!

SLAVE MODEL

AP 100 100W RMS £69
AP 200 200W RMS £89

2 INPUT GENERAL PURPOSE MODEL

AP 100S £79
AP 200S £99

P.A. MODEL

★ 6 INPUTS
★ 3 CHANNELS
★ ECHO IN/OUT

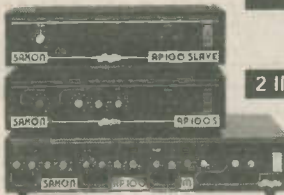

★ TREBLE/BASS EACH CHANNEL ★ INDIVIDUAL VOLUMES
★ MASTER PRESENCE

Write or phone for a FREE BROCHURE on these incredible amplifiers

AP 100M £99
AP 200M £119

P.E. HYPERCHASER

£84.95



4 CHANNEL PSEUDO INTELLIGENT LIGHT UNIT

★ 16 Programmes
★ Manual Flash Buttons
★ 4 Independent Channels
★ Strobe Outputs
★ Individual Dimming
★ Sound To Light

Not just a light unit but a sophisticated & comprehensive effects unit. A full kit of parts including P.C.B., Facia, Case, etc. Reprint of article on request.

P.E. STAR DESK

£209



8 + 4 CHANNEL LIGHT MIXING DESK

★ 8 Channel Twin Preset Mixer
★ Strobe Outputs
★ 4 Independent Channels
★ 4/8 Channel Sequences
★ 8 Programmes
★ Manual Flash Buttons
★ 1KW Output/Channel (can be boosted to 2KW/Ch)
★ Timed Crossfade
★ Soft/Hard Sequence

A truly magnificent unit ideal for clubs, groups, drama, etc. A full kit of parts inc. PCB, Facia, Case, etc. Reprint of article on request.



BENSHAM RECORDING LTD

327 Whitehorse Road, Croydon, Surrey CR0 2HS
(01) 684 8007
9am-5pm Mon-Sat



All prices include VAT and Post & Packing. Please allow 14 days for delivery

SEMICONDUCTOR CIRCUITS

TOM GASKELL BA (Hons) CEng MIEE

TEMPERATURE SENSOR (LM35)

Of all the physical parameters that can be measured using electronics, temperature is one of the most commonly required, yet the measurement of temperature can be deceptively difficult to implement simply and accurately. For many years the standard temperature sensor has been either the thermistor, which varies its resistance with temperature, or the thermocouple, which produces a tiny voltage proportional to temperature. Unfortunately, both these approaches have considerable problems over the normal range of temperatures; non-linearity, the requirement for cold-junction compensation, etc. As a result, complex circuitry is often necessary to compensate for these effects, and the resultant systems are often costly, difficult to calibrate,

and can still exhibit problems of reduced accuracy and drift.

Silicon diodes can be used as temperature sensors when forward biased and fed with a constant current. Again, though, the results can be difficult to calibrate accurately over a wide temperature range, and very difficult to reliably repeat. Over the last few years a number of integrated circuits have been produced specifically for the purposes of temperature sensing; the LM3911 is a popular device, and the more recent LM335 and AD590 are excellent and accurate sensors. All of these i.c.s, however, produce outputs which vary as a function of the temperature in degrees Kelvin. Degrees Kelvin is the temperature (in degrees 'centigrade') above absolute zero, -273.2°C .

Hence, these sensors always require 273.2° effectively subtracting from their outputs. The LM35, however, is a highly accurate new temperature sensing i.c. from National Semiconductor, which features an output which is

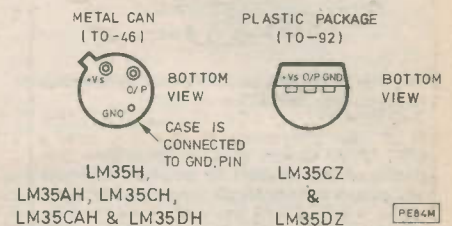

Fig. 1. Pinouts

Characteristic	Notes	Minimum Value	Typically	Maximum Value	Units
Supply voltage	All spec's measured at +5V unless otherwise stated	+4		+30	V
Quiescent current— LM35AH, LM35CAH	At +25°C Maximum, over full temp. range		56	67	μA
Quiescent current— LM35H, LM35C, LM35D	At +25°C Maximum, over full temp. range		56	80	μA
Change in quiescent current	Supply varying from +4V to +30V full temp. range		±0.5	±3	μA
Temperature coefficient of quiescent current	LM35AH, LM35CAH LM35H, LM35C, LM35D		+0.39 +0.39	+0.5 +0.7	μA/°C
Output current				10	mA
O/P load regulation (0 to 1.0mA, full temp. range)	LM35AH, LM35CAH LM35H, LM35C, LM35D		0.5 0.5	3.0 5.0	mV/mA
O/P line regulation (4V to 30V supply, full temp. range)	LM35AH, LM35CAH LM35H, LM35C, LM35D		0.02 0.02	0.1 0.2	mV/V
Minimum temperature for rated accuracy	In circuit of Fig. 3a (no load current)		1.5	2.0	°C
Long term stability	Maximum temp. for 1,000 hours		0.08		°C
Sensor gain (average slope)	LM35AH, LM35CAH LM35H, LM35C, LM35D		+10.0 +10.0	+10.1 +10.2	mV/°C
Non-linearity (deviation from slope)	LM35AH LM35CAH LM35H LM35C, LM35D		0.18 0.15 0.30 0.20	0.35 0.30 0.50 0.50	°C
A C C U R A C Y	LM35AH & LM35CAH	At +25°C	±0.2	±0.5	°C
		At maximum temp.	±0.4	±1.0	°C
	LM35H & LM35C	At minimum temp.	±0.4	±1.5	°C
		At +25°C	±0.4	±1.0	°C
	LM35D	At maximum temp.	±0.8	±1.5	°C
		At minimum temp.	±0.8	±2.0	°C
	LM35D	At +25°C	±0.6	±1.5	°C
		At maximum temp.	±0.9	±2.0	°C
LM35D	At minimum temp.	±0.9	±2.0	°C	

N.B.
"LM35C" refers to LM35CH and LM35CZ
"LM35D" refers to LM35DH and LM35DZ

Fig. 2. Specifications

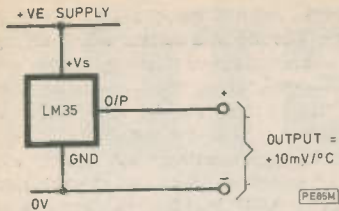

Fig. 3a. Basic temperature sensor +2°C to +150°C

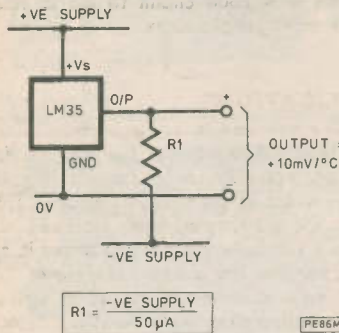

Fig. 3b. Full range temperature sensor -55°C to +150°C

directly proportional to degrees centigrade. No degrees Kelvin offset is necessary.

THE RANGE OF DEVICES

Fig. 1 shows the pinouts, and Fig. 2 the specifications of the LM35 range of i.c.s. The LM35CZ and the LM35DZ are the most commonly found devices, with the others in the series being more accurate but more costly. The operating range of the different devices also varies; the LM35H and LM35AH are designed to work over the range -55°C to +150°C, the LM35CH, LM35CAH and LM35CZ over the range -40°C to +110°C, and the LM35DH and LM35DZ over the range 0 to +100°C. In all the circuit diagrams the term 'LM35' on its own is used—the exact type of device depends on the required temperature range, accuracy and package type.

The i.c.s all produce an output voltage which is directly proportional to the temperature in degrees centigrade, the actual output voltage being +10mV per degree. The circuit of Fig. 3a is capable of working over the range +2°C to +150°C. (The top limit, of course, is +110° for the LM35CH, CAH, or CZ, and +100° for the LM35DH or DZ.) If negative output voltages, corresponding to temperatures below 0°C, are required, then the circuit of Fig. 3b must be used. Here, the output is biased to a negative supply voltage via R1. Again, the temperature range is reduced for some of the devices, as described above.

The i.c.s are high-quality devices, with excellent guaranteed accuracies, and typical accuracies of the order of $\pm\frac{1}{2}\%$ or better at room temperature, and $\pm 1\frac{1}{2}\%$ over the entire temperature range. Their output impedance is very low (typically 0.1 ohms for a 1mA load) which makes interfacing to other circuitry especially easy. The supply voltage range of

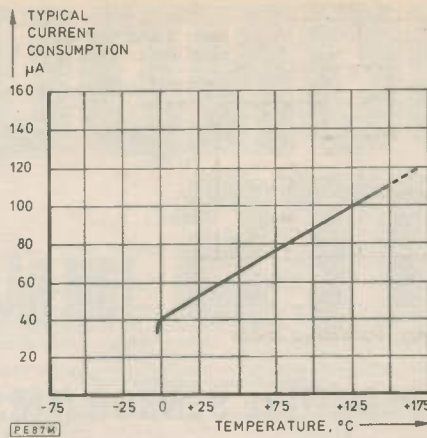

Fig. 4a. Power supply current vs temperature in circuit of Fig. 3a

+4V to +30V is very wide, and the typical quiescent current at room temperature is 60µA, making the i.c.s ideal for use in battery-powered circuits. Because of this low quiescent current the LM35 keeps the self-heating effect down to below 0.1°C, which again helps the overall accuracy. (Self-heating is the effect whereby the internal power consumption of a device raises its own internal temperature, giving a false increase in output voltage.)

VARIATIONS IN QUIESCENT CURRENT

The current taken by the LM35 from a power supply will vary with temperature, and will, of course, be increased if any current has to be driven into a load by the output terminal. Figs. 4a and 4b show the effects of temperature on the current flowing into the +Vs pin of the i.c. in the circuits of Fig. 3a and Fig. 3b. The current consumption of the full range temperature sensor is considerably higher than the limited range one due to the load current flowing into R1. This in turn will cause more power to be dissipated in the i.c., increasing its self-heating slightly.

MORE COMPLEX CIRCUITS

So far we've considered only 'single ended' outputs from the i.c. This means that we look between the output of the i.c. and 0 volts. However, if we are prepared to look *differentially* at the output of the i.c. and associated circuitry, we can employ a number of useful circuit techniques.

A wide range thermometer is shown in Fig. 5 using only a single supply rather than the dual supply of Fig. 3b. A pair of silicon signal diodes raise the ground terminal of the LM35 by typically 0.85V in total. The forward drop of the diodes is less than the normally quoted 0.65V each due to the very low current being passed. The 18k resistor acts as the negative bias resistor R1 in Fig. 3b, and the output voltage is measured differentially between the output and ground terminals of the LM35. In most applications an op-amp would be used to take this differential voltage and process it as necessary for use in the remaining circuitry.

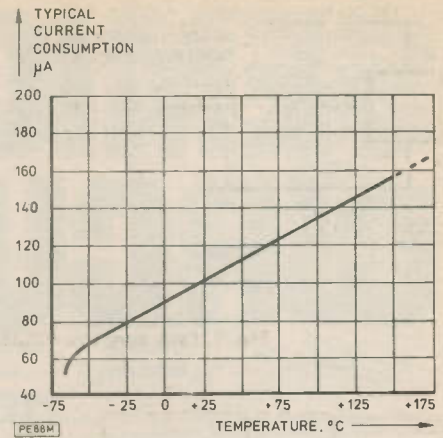

Fig. 4b. Power supply current vs temperature in circuit of Fig. 3b

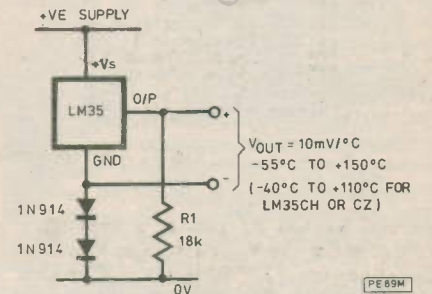

Fig. 5. Wide range thermometer

Note that this circuit could have errors at temperatures below 0°C due to the variation of forward voltage drop of the 1N914 diodes with temperature typically -2mV/°C for each diode. This will vary the current through the 18k resistor, which could result in errors. At higher temperatures the variation of current will have no effect on the output voltage of the i.c.

The circuit for a fahrenheit sensing thermometer is shown in Fig. 6. Here, the ground terminal of the LM35 is raised up from 0V by a precision bandgap reference i.c. The voltage across this reference will have negligible variation with temperature or with quiescent

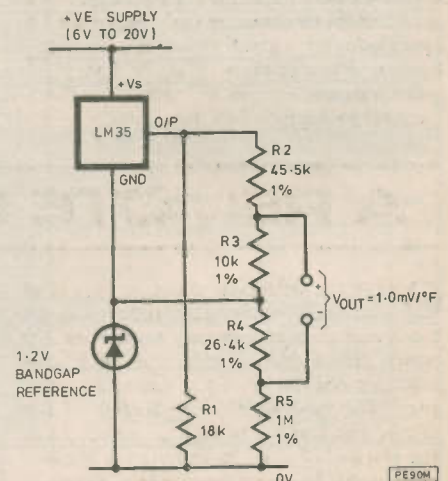

Fig. 6. Fahrenheit thermometer

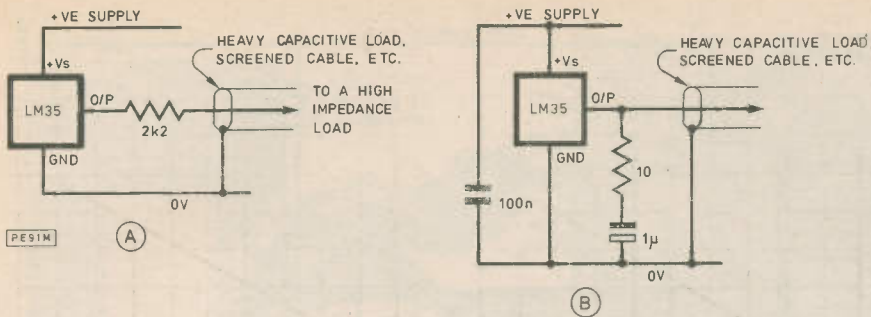

Fig. 7. Isolating the LM35 from capacitive loads

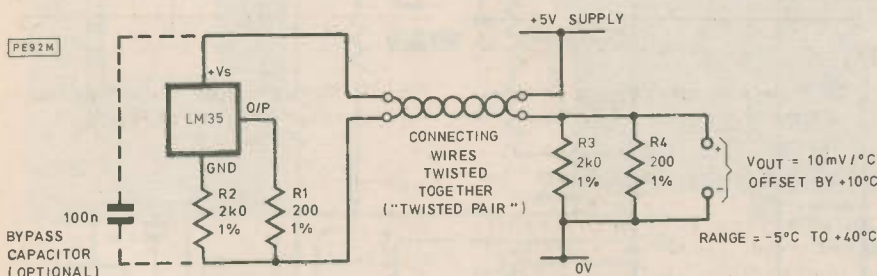

Fig. 8. Remote temperature sensor

current. R4 and R5 provide a fixed offset voltage at the $-ve V_{out}$ connection. This is required because $+32^{\circ}$ Fahrenheit is equivalent to 0° Centigrade. R2 and R3 in turn act as a potential divider across the output of the LM35 to reduce the change in output with temperature. V_{out} is not taken to be $1.0mV/^{\circ}F$, rather than the usual $10mV/^{\circ}C$.

CAPACITIVE LOADS

Like many low power circuits, the LM35 has only a limited ability to drive capacitive loads, and is only able to drive up to 50pF without needing special precautions to be taken. If higher load capacitances than this are to be used, for example, when driving a length of screened cable, then one of the arrangements shown in Fig. 7 should be used. In Fig. 7a a series resistor is used to isolate the capacitance from the i.c. output. This is a simple solution, but requires a high impedance load, and the resultant high driving impedance can make the output susceptible to interference. The circuit of Fig. 7b has p.s.u. decoupling and a series RC network to damp the LM35's output. This arrangement works

well, preventing instability and rejecting interference.

REMOTE SENSING

In some cases it is necessary to have the temperature sensor some considerable distance away from the remaining circuitry. Screened cable can be used, but as described above it is necessary to take special precautions to prevent instability and interference. Over very long distances the voltage drops due to cable resistance can be significant.

An interesting application of the LM35 as a 'two wire' temperature sensor is shown in Fig. 8. The i.c. is arranged as a temperature dependent current source, with R2 raising the ground terminal voltage slightly to allow limited sensing of temperatures below $0^{\circ}C$. Ideally, the connecting wires should be twisted together along their length to minimise interference. This is easily done by fixing the wires at one end, and splicing them at the other end with a hand or electric drill. The current flowing down the wires is a summation of the quiescent current flowing through R2, and the output current flowing through R1. This

current is converted back to a voltage by R3 and R4. The use of a current driven arrangement makes the circuit relatively insensitive to voltage drops along the connecting wires. Note that the resistors must be 1% tolerance, preferably high stability metal film types, as any variation of resistance will directly affect their output voltage. Also note that the output is offset by $+10^{\circ}C$; at $0^{\circ}C$ the output will be $+100mV$, at $+20^{\circ}C$ the output will be $+300mV$, etc. Although not a low current arrangement, due to the low load resistance R1, this is a good circuit to use in many remote sensing applications.

APPLICATIONS

We've now looked at many circuits using the LM35. Obviously, its potential applications are very diverse and cover most instances where temperature measurement is required. On the simplest level, the LM35 can have a 9 volt battery connected across it, and be used to feed into a digital multimeter. This would make an extremely simple, yet high accuracy, temperature probe for the DMM. If the DMM was set to 1.0V full scale, the reading would correspond to $\times 100^{\circ}C$; for example, a reading of 0.250 would actually correspond to $25.0^{\circ}C$. Conversely, because of its low output impedance and relatively high drive capability (up to 10mA), the i.c. could directly drive a moving coil meter, via a suitable resistor if necessary. Hence, an accurate thermometer could be built with only the circuit of Fig. 3a, a 9 volt battery, one resistor and a meter. Alternatively, bargraph i.c.s could be used to give an l.e.d. dot or bar representation of temperature. Finally, the LM35 could feed into an analogue to digital converter, to be interfaced with a computer or microprocessor control system.

The LM35 and its associated circuitry must always be kept well insulated and dry. The devices in metal can packages can be soldered to metal plates; either small lightweight heat fins to speed up the response to air temperature changes, or larger masses to give stable readings when the air temperature fluctuates rapidly. When used in this way, however, be aware that the ground terminal of the i.c. will be connected electrically to the metal plate.

The LM35 is an accurate and versatile i.c. which is an excellent basis for many thermometer and temperature sensing circuits. The LM35CZ and LM35DZ are obtainable from Maplin Electronic Supplies.

A REMOTE SENSING THERMOMETER

ONE of the attractions about the idea of an electronic thermometer, rather than the traditional glass and mercury type, is that the actual temperature sensor can be a considerable distance from the thermometer display. The most obvious application of this around the home is to have a readout inside the house of the temperature outside—perhaps in the greenhouse or the garage, or even in the garden pond. The remote sensing thermometer shown in Fig. 9, with its

Veroboard layout in Fig. 11, was designed for just this purpose. It will cover the range $+2^{\circ}C$ to above $+40^{\circ}C$ with high accuracy, and is based on a two-wire principle similar to that shown in Fig. 8.

IC2 is a $3\frac{1}{2}$ digit digital voltmeter (DVM) i.c. It takes in analogue voltages, converts them to a digital code, and directly drives a liquid crystal display. IC4 is a precision bandgap reference, generating a 1.22 volt reference, and IC1 is the LM35 sensor, con-

nected as a temperature dependent current sink.

DETAILED OPERATION

IC1 has a 2k2 load resistor, R13 (Fig. 10). Unfortunately, the circuit of Fig. 8 is quite heavy on current, and this circuit is intended for continuous battery operation, so a higher resistor value has to be used. The quiescent current of IC1 is similar to the load current into R13, so rather than look directly across R6

Fig. 9. Remote sensing thermometer

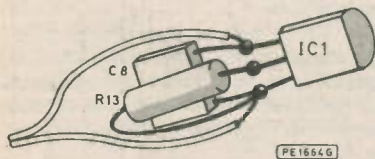
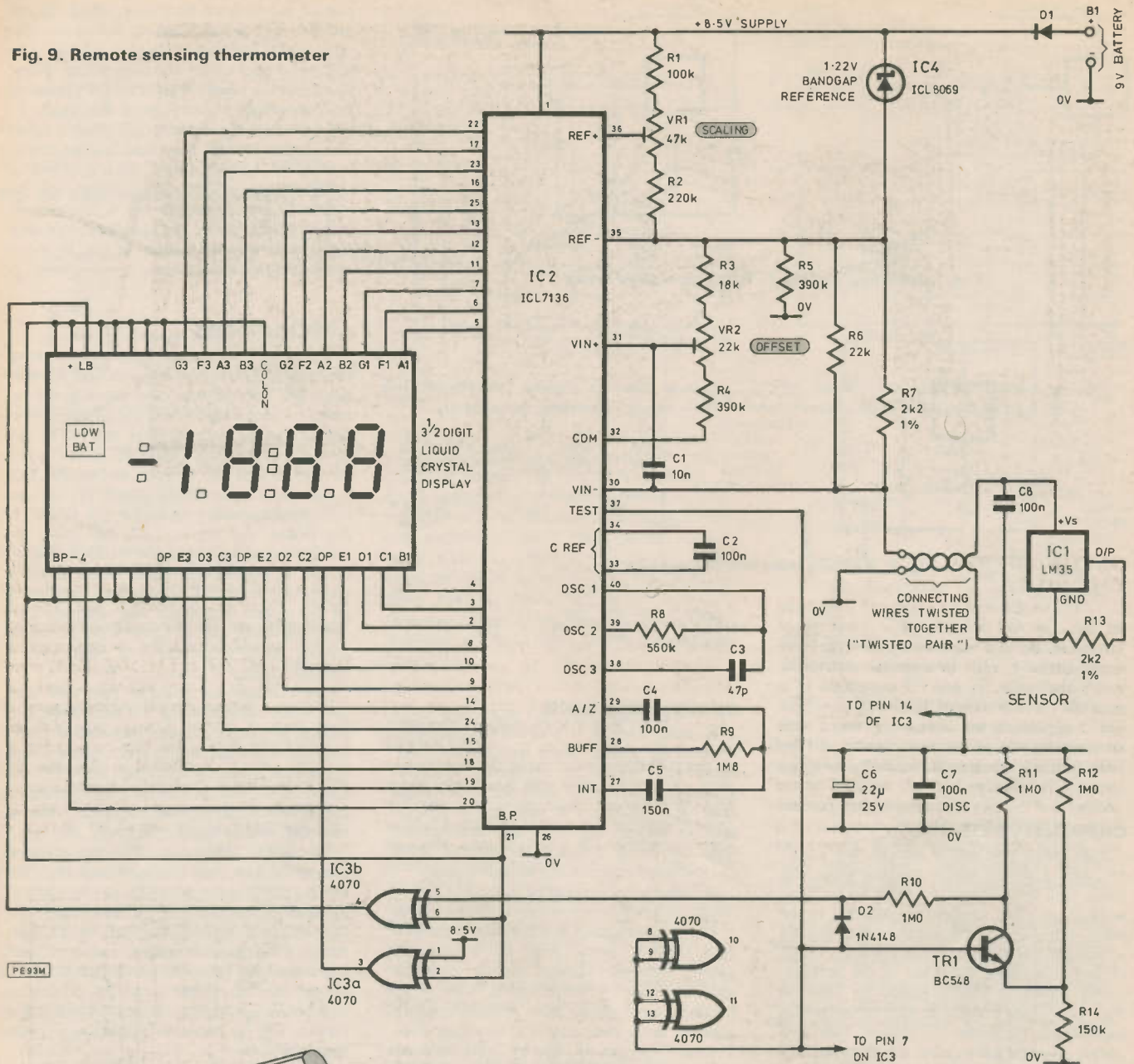

Fig. 10. Sensor construction

and R7 as the Fig. 8 type of arrangement would have done, we must offset the input to IC2 by an amount corresponding to that quiescent current, leaving only that voltage which corresponds to the temperature. The 'com' output of IC2, pin 32, is held internally at approximately $-3V$ with respect to the supply voltage at pin 1, so the offsetting voltage is derived from this $-3V$ output and the $-1.22V$ reference (referred, again, to the positive supply at pin 1) generated by IC4, R3, R4 and VR2. C1 reduces h.f. interference.

The scaling of IC2 is determined by the dif-

ferential voltage between pins 35 and 36. The 'full scale' sensitivity of IC2 is twice the voltage between pins 35 and 36. For a $100mV$ difference, the full scale sensitivity would be $200mV$, whereas in this case the voltage will be nearer to $1V$ giving approximately a $2V$ full scale sensitivity.

TR1 with its associated resistors is a low voltage detector. When the battery voltage drops to approximately $7.5V$, TR1 turns off, allowing pin 5 of IC3b to be pulled up to a logic 1 level, thus inverting the backplane (B.P.) drive signal from pin 21 of IC2 to feed to the 'LOW BAT' indicator on the liquid crystal display. IC3a permanently inverts the backplane drive to keep the decimal point turned on. This arrangement of EX-OR gating is necessary because liquid crystal displays must never be fed with d.c.; the feed to each seg-

ment must always be exactly in phase with the backplane signal (keeping the segment turned off) or exactly out of phase with it (keeping the segment turned on). The backplane signal itself is a low frequency square wave. All unused segments should be connected to the backplane signal. Note that the negative supply to IC3 comes from the test output of IC2, not $0V$, to ensure compatibility with the drive voltage to the liquid crystal display.

D1 helps to prevent damage if the battery is accidentally connected the wrong way round, C6 and C7 decouple the supplies, and R5 ensures that sufficient current flows through IC4 to keep it operating correctly, even at very low sensor temperatures. C2, C3, C4, C5, R8 and R9 all arrange for the correct operation of IC2, with measurements of temperature being made at the rate of one per second.

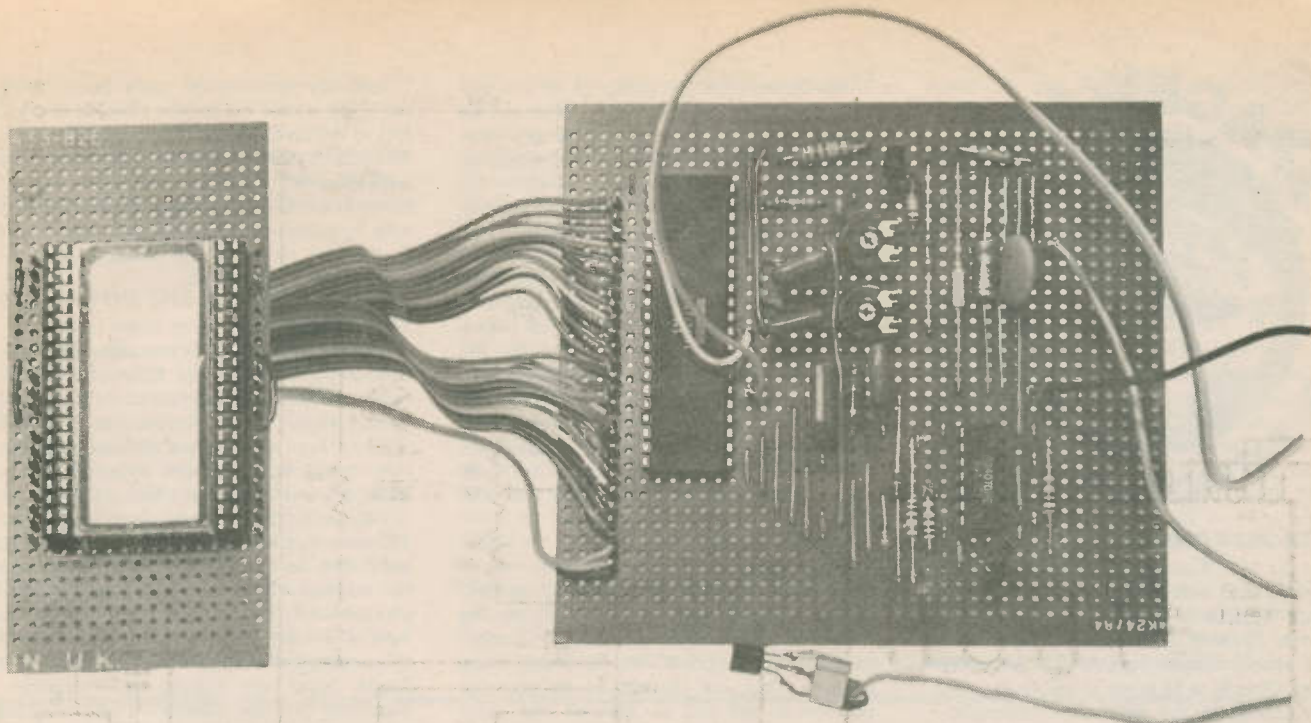

SETTING UP THE CIRCUITRY

IC1, with C8 and R13 soldered directly to its leads, should be enclosed in a waterproof container. If the components can actually be encapsulated in resin or a similar material so much the better. A good arrangement is to coat all the components in epoxy glue, let it set, then push the whole assembly into a piece of copper tube, sealed at the end and filled with heatsink compound. Basically, anything that keeps moisture out, lets heat get to the sensor, and ensures that the circuitry remains insulated, will suffice. The connecting wire is not at all critical, although it will help if it can

be twisted together along its length.

This rather unusual circuit arrangement has a low supply current of typically $250\mu\text{A}$ at room temperature, and can operate with several hundred feet of wire between the sensor and the circuit. The penalty for this arrangement is that it does require calibrating, preferably using a known temperature, just above $+2^\circ\text{C}$, and a known higher temperature—say a jug of water at $+40^\circ\text{C}$. An excellent calibration standard at the higher temperatures is a Paterson photographer's colour spirit thermometer; these are very economical to buy, and extraordinarily accurate. The two presets are interactive, so it takes a while to

get it spot on, but perseverance will pay off! With a set of 6 alkaline 'AA' size batteries, the battery life should be nearly a year. The accuracy obtained will be partially dependent on the type of LM35 used, but for most applications the LM35CZ or LM35DZ should more than suffice. The circuit techniques used will introduce a certain amount of inaccuracy of their own, of course. Finally, note that the liquid crystal display has been mounted on a separate piece of Veroboard to allow the display to be fixed to the front of a suitable case, if required. (Most $3\frac{1}{2}$ digit l.c.d.s have exactly the same pinout as the one shown in Figs. 9 and 11.)

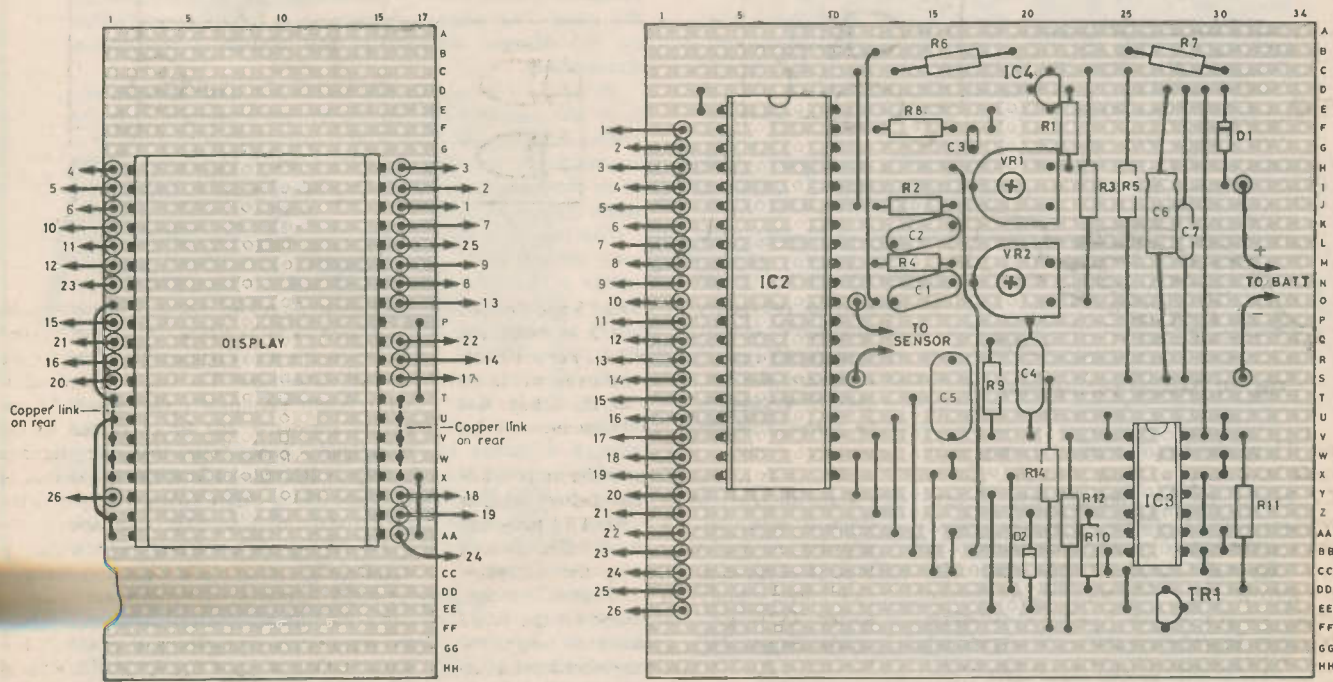

Fig. 11. Veroboard layout

PE1663GA



BETA PICTORIS

In the March issue I wrote about Beta Pictoris, the star which has been found to show visual indications of what may well be a planetary system. There has now been an official announcement from NASA that a concerted effort is to be made to search for extra-solar planets by the astrometric technique—that is to say, measuring the tiny perturbations of stars due to invisible orbiting companions of planetary rather than stellar mass.

The Ames Research Center of NASA and the University of Arizona hope to launch an orbiting Astrometric Telescope Facility from the planned Space Station some time during the 1990s. The measurements will be so delicate that to carry them out with a ground-based telescope is very difficult indeed.

For example, the greatest disturbance in the motion of our Sun, due to the pull of Jupiter, causes the Sun to oscillate back and forth over about a million miles in a period of twelve years—and this distance is only twice the Sun's own diameter, which is not very much. There have been reports that a few nearby stars (notably Barnard's Star, a dim red dwarf six light-years from us) do show significant perturbations, but the evidence is not conclusive, and much may be hoped from the A.T.F. if it goes ahead on schedule.

Searches are also being made for the highly luminous, unstable Wolf-Rayet stars, which show bright emission lines in their spectra. Quite a number are known, such as the second-magnitude Gamma² Velorum (unfortunately too far south to be visible from Britain). They are thought to be potential supernovae, and can be detected over great distances; over twenty have been identified in the Triangulum Spiral, Messier 33, which is well over 2,000,000 light-years away.

Intensive searches for more Wolf-Rayets are being carried out at Kitt Peak, in Hawaii, and at the Cerro Tololo Observatory in Chile. All these observatories are equipped with very large reflectors. From Kitt Peak also comes an interesting note on the galaxy II Zw 23, which may be exceptionally young and, indeed, still in the last stages of its collapse from its original cloud of material.

TELESCOPES

This is the age of great telescopes. It is now over 35 years since the Palomar 200-inch reflector came into operation; it is still the second largest in the world, but it is less 'modern' than some others, such as the reflectors at Kitt Peak, Hawaii, Siding Spring in Australia, and the observatories in Chile.

For sheer size, pride of place goes to the 236-inch Russian reflector in the Caucasus, but unfortunately there are still problems with this colossus, and it has yet to come up to expectations. We must therefore ask whether the limit of size has been reached for Earth-based telescopes, and whether we must pin all our future hopes on orbiting observatories—beginning with the Hubble 94-inch reflector which should be launched in the near future.

This may not be entirely true. Segmented mirrors are now practicable, and there is also

THE SKY THIS MONTH

This is a poor month for planetary observers. Venus passes through inferior conjunction on 3 April, and is briefly out of view, but it soon reappears in the morning sky, and will be again very brilliant toward the end of the month; it will indeed remain so for most of the rest of the year. Mercury also passes through inferior conjunction on 3 April, a mere eight hours before Venus, but it will subsequently be well south of the celestial equator, and British observers will not see it with the naked eye.

Mars is visible in the evening sky, low above the western horizon, but it is now a long way away and not much brighter than the Pole Star. On 22 April it is actually occulted by the Moon, but this occurs during daylight, and will be a difficult phenomenon to observe (the Moon will be only two days old). Both the giant planets are morning objects; Jupiter is very bright, and Saturn has reached a magnitude of 0.4, but both are well south of the equator, and are inconveniently low down—though Saturn's rings are wide open, making the planet a superb telescopic object.

Incidentally, Pluto is at opposition on 23 April, in Virgo. Its distance from us is then slightly over 4,300,000,000 kilometres, but its magnitude is only 14, so that a telescope of fair size is needed to show it. Sadly, none of the current space probes will go anywhere near it, and we may have to wait for a long time before we can find out more about this strange, puzzling little world and its satellite Charon.

METEOR SHOWER

The Eta Aquarid meteor shower begins late in the month. The limiting dates are usually given as 24 April to 20 May, and the ZHR is around 40—the ZHR being the number of naked-eye meteors of the shower which would be visible to an observer under ideal conditions, with the radiant at the zenith (conditions which, needless to say, are virtually never attained).

Interest this year centres on the fact that the Eta Aquarids, like the October Orionids, are associated with

Halley's Comet. At the last return of the comet, in 1910, there was apparently no increase in the associated meteor showers, but one never knows, and it is hoped that observers will do their best to monitor the Eta Aquarids this year, either visually or by radar or radio methods.

Unfortunately the radiant is rather low, and the best chances will be from southern-hemisphere countries, but certainly British meteor-watchers will be very much on the alert. The visual programme is being co-ordinated by the Meteor Section of the British Astronomical Association.

By now we have virtually lost Orion, and the night sky is all the poorer for it; of the Hunter's retinue, only the Twins and Capella remain at a respectable altitude. It is interesting to compare Capella with Vega in Lyra, which is on the opposite side of the Pole Star and at about the same distance from it.

The two are almost equal in brilliancy, but they are very different in colour. Capella is a yellow star—or rather a pair of yellow stars; it is a very close binary. Vega is glorious blue, and has acquired extra interest lately as being one of the stars found by IRAS, the Infra-Red Astronomical Satellite, to be associated with cool material which may be planet-forming.

The Great Bear, Ursa Major, is almost overhead; follow the curve of the 'tail' and you will come to the orange Arcturus in Boötes (the Herdsman), which is slightly brighter than Capella or Vega, and is actually the most brilliant star ever visible from Britain apart from Sirius. In the south Leo, the Lion, is dominant, with the bright Regulus and the curved line of stars marking the so-called Sickle.

Below Leo the region of sky appears barren; it is occupied largely by Hydra, the Watersnake, which contains little of interest. Note the fairly conspicuous little quadrilateral of stars making Corvus (the Crow) low in the south, followed by the first-magnitude Spica, leader of Virgo (the Virgin).

the multiple-mirror design pioneered by the M.M.T. at the Whipple Observatory on Mount Hopkins, in Arizona. The NNTT, or National New Technology Telescope, will use four co-ordinated 7.5-metre mirrors, giving a light-grasp equal to that of a single 15-metre mirror.

SCOPE FOR THE AMATEUR

But what about telescopes within the range of amateur observers? This is very much of a topical subject in view of the approach of Halley's Comet, and I have been receiving a flow of letters asking for my advice upon what sort of telescope to obtain.

All I can do is to give my own views, with the knowledge that not everybody will agree with them. Of course, much depends upon the main interest of the observer; an enthusiast for solar work will need equipment different from that of the planetary or variable star worker. But the main principles do, I feel, hold good; and I would not recommend paying a large sum of money for a very small telescope.

Probably the minimum useful aperture for really satisfactory observation is 3 inches for a refractor and 6 inches for a reflector. Anything smaller than this will have marked disadvantages. It will have a small field of view; it will not stand a high magnification, and it will not be easy to use, particularly as (in many cases) the mounting is too lightweight. I am not in the least impressed by the spindly 2- and 2½-inch refractors and the 3- and 4-inch reflectors which can be bought for a few tens of pounds.

A really satisfactory telescope is an expensive item if bought new—and good second-hand telescopes are now about as common as Great Auks. Probably £200 is the lower limit; and if you are prepared to spend this sort of sum, it is surely best to wait and collect rather more, so that you can buy something really good.

Also, bear in mind that if you want to photograph Halley's Comet, you will need a telescope which is not only good optically, but also mounted upon a stand which can be effectively driven, preferably by mechanical

means. A time-exposure is essential. Hand-guiding is not out of the question if the mounting is equatorial, but an automatic drive makes matters a great deal easier.

I agree that the sums involved seem large—but remember that they are non-recurring; if well looked after, a telescope needs comparatively little maintenance, and after all, compare the price of a telescope with that of a couple of return tickets on British Rail between, say, London and Glasgow . . .

Reflectors can be made from scratch; many amateurs have constructed excellent instruments, including the optics. Another way out is to buy the optics and then make the mounting. But if all else fails, and you want to see Halley's Comet as early as possible, then I would suggest good binoculars, which have most of the advantages of a very small telescope, apart from sheer magnification, and few of the drawbacks.

By this autumn, Halley's Comet will be within binocular range. Let us make the most of it; few of us will survive to see it when it comes back once more in the year 2061!

MAY FEATURES...

AMSTRAD CPC 464 AMPLIFIER



If you own an Amstrad CPC 464 microcomputer why not build our stereo amplifier add-on, and give your machine true arcade quality sound effects when running games. The amp will also prove handy when developing multi-channel sound programs.

AUTO PHASE

Musicians—Build a really nasty foot controlled effects box. To be different, this phaser uses signal amplitude to shape the envelope. Auto-phaser is simple and economical to construct.

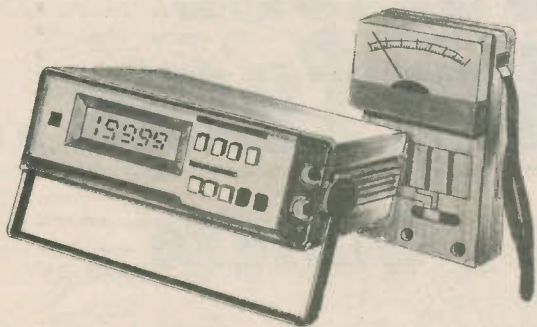

MULTIMETER BUYER'S GUIDE...

For most hobbyists the multimeter is the first major investment in serious electronic construction. Our guide will help to ensure that this investment is well made.

VOLTAGE PROBE

This very useful hand-held probe is easy to use and gives an instant bar-graph display of voltage levels up to 12 volts on the low range, and up to 120 volts on the high range.

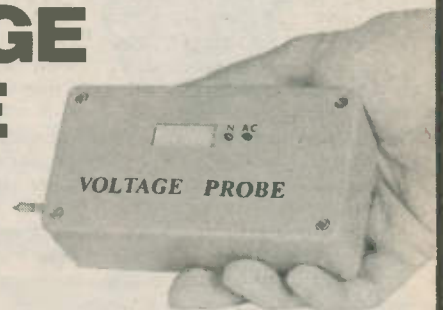

EVERYDAY ELECTRONICS and computer PROJECTS

MAY 1985 ISSUE ON SALE FRIDAY, APRIL 19
ORDER YOUR COPY FROM YOUR NEWSAGENT NOW!

THE teleprinter has been with us for a great many years, but the telegraphic codes that are used with it have a history which takes us back at least to the year 1753, when a letter appeared in the Scots Magazine headed "AN EXPEDITIOUS METHOD OF CONVEYING INTELLIGENCE". The letter went on to describe a system of parallel communication using "... An arrangement of wires corresponding to the number of letters of the alphabet ...". However, public use of the Electric Telegraph, as it was then known, was not to begin for almost a century, by which time the system of serial transmission which we know as Morse code had been devised.

SERIAL TRANSMISSION

Development in the telegraphic field must have been fast and furious in those days, since Chamber's Encyclopaedia, published in the year 1882, is able to speak of the Hughes Type-printing Instrument, and of the transmission of hand-written material by facsimile.

In 1874, a Frenchman by the name of Emile Baudot devised the telegraphic code which bears his name, and which set out the main principles of serial code used today. Perhaps the Baudot code was ahead of its time, since at the turn of the last century the bulk of telegraphic communication was still by means of Morse code. In 1902, devices which might well be considered to be the forerunners of the teleprinter were introduced, both in the USA and in the UK. The American model used Baudot's code whilst the British machine used a typewriter keyboard to perforate paper tape with a representation of the Morse alphabet. This last instrument was soon to be followed by a separate receiver which accepted Morse punched tape, and produced a typewritten message.

During the next few years, a great deal of thought was given to the improvement of the codes and surviving from the early days of telegraph are the terms "mark" and

"space", referring originally to the use of an electrically operated pen to record Morse code on moving paper as a series of marks (dots and dashes) separated by spaces. As may be imagined, a large number of different serial telegraphic codes came into being, each suited to a specific piece of equipment. Even when the early teleprinters came into general use in this country, the Murray teleprinter alphabet, an improvement of the Baudot code, which had been accepted as the standard, existed in several variant forms.

As the need for worldwide communication grew, and a widespread network of submarine telegraph cables was installed, code conversion became a great problem: solved at length by the introduction of a development of the Murray code known as the International No. 2 Alphabet. This is a five unit code, and is the alphabet used today. This is the code which will be discussed here in detail, as it is the transmission system for which the majority of the teleprinters available on the surplus market are designed.

The principle of the Murray code and of all subsequent serial data transmission codes, including the now familiar ASCII codes, is similar. The code consists of a series of marks, separated by spaces, and obeying the following rules:

- (1) The total number of marks and spaces in each character transmitted is equal to that of any other character (five elements in total in the case of the No. 2 teleprinter alphabet).
- (2) The length of each element of the code, be it mark or space, is equal to that of any other.
- (3) Each character is preceded by a start element which is equal in length to one code element, and is always of opposite condition to the normal or rest condition of the transmission.
- (4) A stop element follows each character, and this may have a greater length than the other elements. The stop element always takes the rest condition of the line, and is therefore of opposite condition to the start element.



Teleprinter Interface...

B. Drake

Letter	Figure	Code	Binary code	Decimal
A	—	MMSSS	10011100	156
B	?	MSSMM	10110000	176
C	:	SMMMMS	11000100	196
D	WRU	MSSMS	10110100	180
E	3	MSSSS	10111100	188
F	%	MSMMS	10100100	164
G	@	SMSMM	11010000	208
H	£	SSMSM	11101000	232
I	8	SMMSS	11001100	204
J	BEL	MMSMS	10010100	148
K	(MMMMS	10000100	132
L)	SMSSM	11011000	216
M	.	SSMMM	11100000	224
N	,	SSMMS	11100100	228
O	9	SSSMM	11110000	240
P	0	SMMSM	11001000	200
Q	1	MMMSM	10001000	136
R	4	SMSMS	11010100	212
S		MSMSS	10101100	172
T	5	SSSSM	11111000	248
U	7	MMMSS	10001100	140
V	=	SMMMM	11000000	192
W	2	MMSSM	10011000	152
X	/	MSMMM	10100000	160
Y	6	MSMSM	10101000	168
Z	+	MSSSM	10111000	184
CARR. LINE	RET. FEED	SSSMS	11110100	244
LET. FIG.	SHIFT SHIFT	SMSSS	11011100	220
		MMMMM	10000000	128
		MMSMM	10010000	144
SPACE		SSMSS	11101100	236

M=MARK S=SPACE BINARY '1'=SPACE
BIT 7=START ELEMENT: BIT 1=STOP ELEMENT
BIT 0 IS NOT USED.

Table 1. The complete 5-bit code listing

Subject to these rules, the actual condition of the line during a mark or a space does vary from network to network, and various voltages with differing signs are encountered for the mark and the space condition. The convention in the UK, however, is for a signal in which the potential is switched from +80 volts (space condition), to -80 volts (mark condition). The rest condition is the mark condition, and therefore the start element is a space. Again in UK convention, it is usual for the stop element to be one-and-a-half elements long.

Table 1 shows the complete alphabet. It will be seen that as the code used has only five elements, there are only 32 possible characters, and one of these is not used.

For this reason, each code is used for two characters, and a shift has to be carried out using the appropriate code before a character from the alternative case is transmitted. Once in the figures mode, the machine remains so until a letter-shift is executed, and vice-versa.

The diagram in Fig. 1 shows graphically how two consecutive characters are transmitted, but in order to follow the time intervals in this diagram, we should first look at the question of transmission rate, and that readily misunderstood quantity, the baud.

BAUD RATE

The term baud rate takes its name from the Baudot code, which is mentioned above, because it related originally to

the rate of transmission of Baudot code. The baud rate is the number of code elements that are transmitted in one second. This means that the rate at which characters are transmitted depends not only on the baud rate, but also on the number of code elements which form a character. It is necessary to be aware of this when comparing baud rates, since there are a number of serial data codes in use with more than five units. For example, ASCII and RS232 codes normally make use of an eight element system plus a start element, or bit in computer terms, and may or may not make use of one bit (the parity bit) for continuous testing for transmission error. As the rate of transmission is determined by the duration of one element, it is evident that an eight unit code character takes considerably longer to transmit than a corresponding character in five unit code.

Most of the teleprinter networks in the UK operate at 50 baud: the length of one code element being 20 milliseconds, and this will be the rate assumed for the rest of this article. A number of teleprinters, for example the Creed model 75, are dual speed, however, being designed to operate at either 50 or 75 bauds. It will be seen later in the article that alterations to the baud rate produced by a computer may be made in a simple manner by adjustments to the delay loops which are used in the software to be described.

Whilst touching upon different transmission codes it should be mentioned that although the 50 baud, five unit code described in detail is the normal system likely to be encountered, other systems are in use and it is possible that a teleprinter which was formerly attached to a radio could be designed for one of two alternative alphabets. These are the 7 element No. 3 alphabet, and the 7 element No. 5 alphabet (the ASCII alphabet).

HARDWARE DESIGN CONSIDERATIONS

The teleprinter uses a single selector operating magnet, which has a resistance of some 200 to 400 ohms depending on the model, and having a current requirement of between 25mA and 70mA, again depending on the teleprinter model. First thoughts that a low operating voltage will be adequate are frustrated when it is realised that pulses of only 20 milliseconds have to be followed, and that the inductance of the solenoid is around 4.5H. In order to achieve a sufficiently short time constant, therefore, operation in a constant current mode is desirable. In practical terms a high voltage, together with a suitably rated current limiting resistance, will enable correct operation to take place.

In considering the various possibilities by means of which output may be taken from a microcomputer, protection of the computer itself has to be the foremost consideration, especially when high voltages are encountered in the external circuitry. For this reason, it was decided to arrange for a

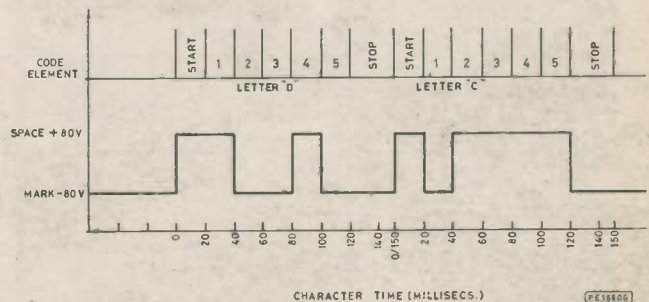

Fig. 1. Transmission of two consecutive characters

signal to be output from the cassette port on the computer, where a simple capacitor will provide adequate isolation from any fault condition. The Sinclair ZX Spectrum, for which the interface circuitry was developed, has a good quality capacitor built into its output, as have most of the computers designed for home use.

As in most cases the isolating capacitor is built in to the computer, the constructor has no control over its value. At the 50 baud rate, the low frequency of the pulse train encountered will give rise to difficulties when a low value of capacitor, together with a resistor network (as in the Sinclair), is provided. This problem was overcome by software written so that each pulse consists of a train of short pulses. The output signal from the computer is normally at 5V, and will therefore require considerable amplification in order to drive the teleprinter solenoid.

The final consideration is that the teleprinter is designed for 110V operation, and in order to allow the interface circuitry to be fitted inside the teleprinter case, the electronics have been arranged to draw power from the teleprinter supply.

INTERFACE CIRCUITRY

A full circuit diagram of the Teleprinter Interface is shown in Fig. 2. The 555 timer i.c. forms the basis of this design. When pins 2 and 6 are tied together and used as the input of a 555, the device operates as a Schmitt trigger, switching at one-third and two-thirds of Vcc. All three 555 i.c.s are used in this mode. The input stage makes use of a special feature provided by pin 5 of the device. This pin controls the switching voltage on the inputs to each of the two internal comparators, and is used here to increase the input sensitivity.

The MJE 340 transistors were chosen to stand up to the back EMF which will be present at the moment of switching. They may be felt to be unnecessarily highly rated; however, the prototype has stood up to many hours of use so far without failure.

POWER SUPPLY

The low voltage section of the power supply is straightforward, making use of a 12-0-12 volt transformer with a 110 volt primary. The prototype uses a small 240 volt

transformer with a secondary of approximately 30-0-30 volts. No more than around 10mA will be required. The solenoid operating supply is taken directly from the 110V supply to the teleprinter. It has therefore been assumed that this supply will be obtained from a good isolating transformer with a fully-floating secondary, as it is intended that the negative rail is able to be connected to the teleprinter case.

INPUT CIRCUIT

IC1 follows the pulses produced by the computer output, and provides at pin 3, a 12V pk-pk pulse train. The diode D7, and R5/C6, provide a time constant which increases the switching time to a period greater than the duration of two pulses. IC2 will therefore be unable to follow the input, but will follow with good accuracy, teleprinter code elements at 50 or 75 bauds. Since a 555 Schmitt operates in the inverting mode, the output of IC2 is used directly to drive IC3, and negligible distortion at zero crossing can be seen. The 555 outputs drive TR1 and TR2 directly, sufficient current passing through R1, and R2 to ensure 'bottoming'.

OUTPUT CIRCUIT

The two output transistors are arranged to be bottomed or cut off depending on the state of drive. It follows that the full potential (rather more than 100V) will exist between the two collectors at any given time, and a current will flow through the electro magnet coils limited by one or the other series resistor.

CONSTRUCTION

Construction does not appear to be critical, and the prototype was assembled on a small piece of Veroboard. R1, R2 and R9 run hot, and should be mounted clear of other components. The driver transistors dissipate very little power unless a fault occurs, and are not fitted with heat-sinks. Components themselves are not critical. The only other point, is to take care to check all wiring as mains voltages are present. The Veroboard layout and wiring diagram is shown in Fig. 3.

SETTING UP

Assuming that the teleprinter had been fully tested in the manual mode, using its own keyboard, few if any problems should arise from that source. When the interface has been

Fig. 2. Complete circuit diagram of the Teleprinter Interface

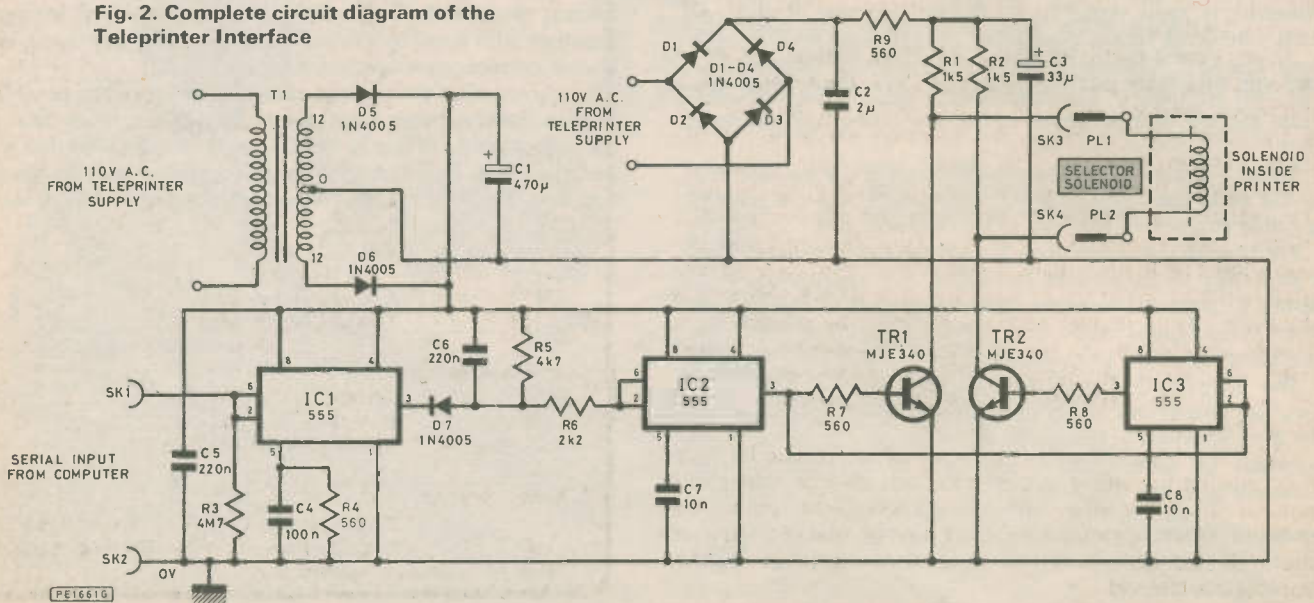

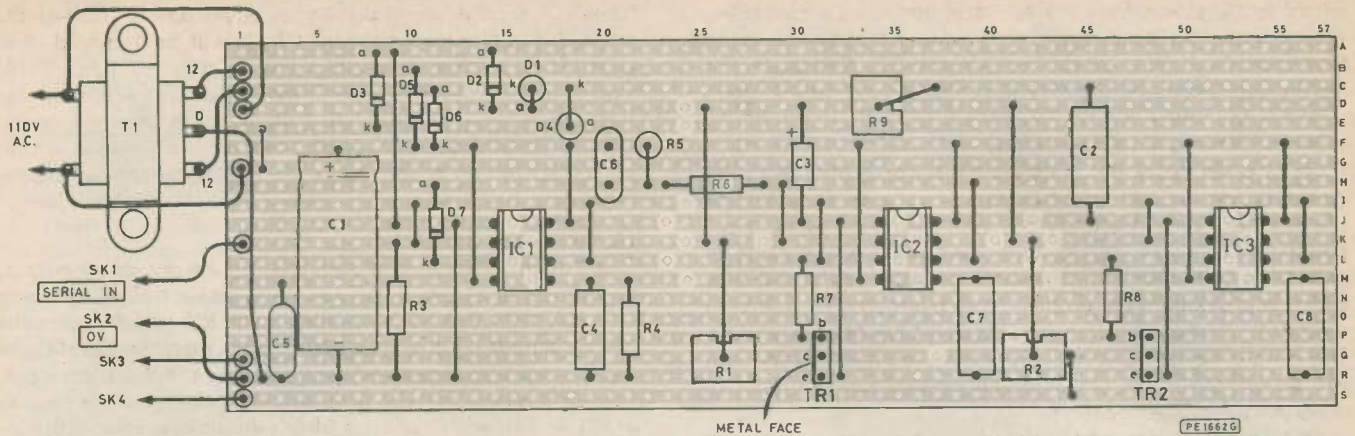
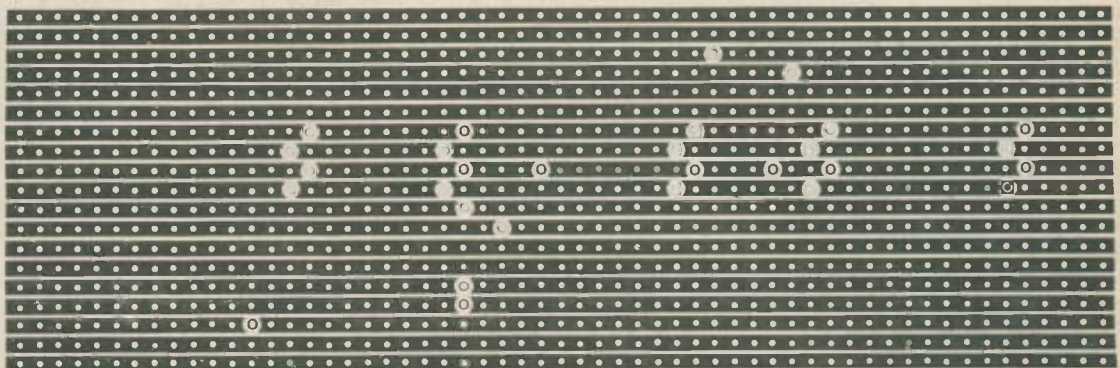

Fig. 3. Stripboard and component layout of the Teleprinter Interface



assembled, it should be connected up to the supply lines, and to the teleprinter solenoid coil. Before power is applied, the armature should be at rest centrally between its stops when the motor is turned so that the selector-dérent is clear of any of the levers, that is between the clutch trigger and the backstop.

In passing it should be noted that some machines are fitted with what appears to be an extra pair of centralising springs on the solenoid armature. These allow a bias to be applied to the armature permitting operation to be carried out with signals of one polarity only. This pair of springs is disconnected for double current operation which is the system used here.

When power is applied to the unit, the armature should be drawn to its mark position. In this position the typehead will not move, even when the motor is operating. If the input line is touched with the finger, the solenoid armature will oscillate at mains frequency if all is well.

If satisfied that there is no spurious earthing to the input connections, and that when connected no difference in d.c. level exists between the interface and the computer, connection should be made. The computer should then be programmed to produce a series of pulse trains at several kHz with a duration of one or two seconds followed by pauses for a couple of seconds. On the Spectrum this can be achieved with the short program in basic shown overleaf in Program 1. The teleprinter motor should be disconnected during this test.

With the program running the armature should be held hard against the space stop during each train of pulses and against the mark stop during the intervals between. The collector of each transistor should then be tested to ensure that it does bottom (less than 1V above negative) during the appropriate interval.

HARDWARE FAULTS

Any faults in the interface itself can easily be traced using a voltmeter at the input and the output of each i.c. in turn. Once the teleprinter solenoid has been made to follow the

COMPONENTS ...

Resistors

R1,R2	1k5 7 watt (2 off)
R3	4M7
R4,R7,R8	560 (3 off)
R5	4k7
R6	2k2
R9	560 7 watt
All resistors 1/4 watt unless shown otherwise	

Capacitors

C1	470µ 18V elect.
C2	2µ paper
C3	33µ 150V elect.
C4	100n polyester
C5,C6	220n polyester (2 off)
C7,C8	10n polyester (2 off)

Semiconductors

D1-D7	IN4005 (7 off)
TR1, TR2	MJE 340 (2 off)
IC1-IC3	NE555 timer (3 off)

Miscellaneous

T1	110V primary, 12V-0V-12V secondary (or 240V primary, 30V-0V-30V secondary)
Veroboard, wire, i.c. sockets, etc.	

slow speed test program suggested, the program should be amended as Program 2, and operation again tested at a pulse rate which is now close to that used at 50 bauds. Once correct operation has been achieved to this point the hardware is complete, and attention should be given to the software required to enable serial code to be output from your computer at the correct baud rate.

```
PROGRAM 1
10 BEEP 60,4
20 PAUSE 200
30 GOTO 10
```

```
PROGRAM 2
10 BEEP 60;.02:GOTO 10
```

SOFTWARE

The first requirement to be met is that of a look-up table of each of the required teleprinter codes. As shown in Table 1, binary versions of each teleprinter code have been used in which binary '1' represents a space, and binary '0' represents a mark. This is done to enable the start element to be a '1', and the stop and rest condition of the output to be '0'. The start element is included in the code, making the most significant bit of each code (the first to be output) always a '1'. The subsequent five bits represent the code elements, and the remaining two the stop bit, these last two being always '0'.

The codes, or rather their decimal equivalent, which is also shown in Table 1, are poked into successive addresses in the memory in ascending order of their respective ASCII codes. In use, they can be "looked up" by offset, that is by adding the ASCII code for the character required to a base address. Although rather slow, this part of the process can successfully be carried out in basic, and the teleprinter code thus collected, poked into an address in the machine code routine which can then be called.

The conversion of the binary code into audio signals at the required accurately measured baud rate can only be carried out by machine code. The bits are read serially using the Rotate Left command, which sets or resets the carry flag according to whether or not the bit rotated out is a '1' or a '0'. The condition of the carry flag then determines whether or not a delay (mark) or a series of pulses (space) are sent to the cassette (MIC) port.

In order to operate the teleprinter at its maximum speed for the baud rate required, the shortest possible delay between the end of the stop element of one character and the beginning of the start element of the next has to be arranged. The count byte in the assembler listing which determines the number of code elements rotated out including start and stop elements can be reduced to six if the time taken to fetch the character, encode it and store it is long (as it will be if basic is used for this purpose).

In order to make optimum use of the teleprinter and to allow its use at 75 bauds as well as at 50, software has been developed. Included in this are a number of subroutines which can be entered separately. The following entry points are normally used.

1) NEWLINE. FF67=65383

This routine executes a linefeed followed by a carriage return and a short delay. It is called from each of the other routines when required, but may equally well be called from basic.

2) START. FFE1=65505

Constructors' Note

A complete listing of the Spectrum computer program for this project is available from our editorial offices for £1, inc. p.&p.

Used at the beginning of printer operation, this routine makes five successive lettershifts to ensure the start-up of the machine, and shift to letters mode before transmission begins. It then executes a call to newline described above.

3) GETSTRING. FFB2=65458

Finds the string the ASCII code for whose name is contained at address 65484 (initialized as P unless the user alters it), and outputs it to the printer.

4) LIST. FC93=64659

Calls "start", followed by a complete listing of the basic program to the printer.

Before a character is encoded, it is examined to see whether it is a letter or a figure, and the previous character is also examined. If the current character requires a different shift to be made from the previous character this is executed prior to encoding the character. In addition, a count has to be kept of the number of printable characters output to the printer on each line. It is arranged that if a space occurs within the last eight characters of the line, the newline routine is called in its place. If a space has not occurred, newline is called in any case. Additionally, at each call to newline, the count is reset for the next line.

A number of other useful routines have been included. These are concerned with characters that are unable to be printed by the teleprinter, and cause a space to be printed in the case of most "unprintables" and a pound to be printed whenever a dollar sign occurs (pounds are better than dollars, anyway!).

ALTERATION TO BAUD RATE

As mentioned earlier in this article, it is a simple matter to alter the baud rate produced to suit any requirement. Referring to the accompanying section of the routine, line 2680 sets up the time for the pulse train required for the transmission of space condition, and line 2860 controls the time of the delay for the transmission of a mark. With the values in the main program (240 and 2688) the code will be transmitted at the rate of 50 bauds. For a rate of 75 bauds, the time of each will need to be reduced in the ratio 50/75. Counts of 160 and 1792 being used.

With the code at the location used by the writer, the address 65113 contains the space count, and addresses 65144 and 65145 the mark delay.

POSSIBLE DIFFICULTIES

The many moving parts in a teleprinter make a full description of possible mechanical faults and remedies outside the scope of this article. There are several books available on this subject, and particular mention should be made of a volume entitled "Teleprinters" published by the Radio Society of Great Britain which has been found especially helpful by the writer.

One fault, however, is almost certain to be encountered by the reader, and that is incorrect motor speed. Motor speed is set up using a stroboscopic tuning fork. The fork frequency is specific to the make and model of teleprinter (140Hz for the Creed 75). It is suggested that the intending constructor should be prepared to buy or borrow such a device, since accurate speed is an absolute essential. ★

ANTEX

a world of soldering



SOLDERING KIT

Free 'How To Solder' booklet and pack of solder



Tomorrows Soldering Technology Today.

ANTEX has a worldwide reputation for quality & service & for many years has been one of the best known & most popular names in soldering. Always at the forefront of technology, ANTEX is continually researching new and better ways of achieving more accurate, reliable, and cost effective soldering. On ANTEX Soldering Irons, the advanced design of the interface between the element & the bit allows more efficient heat transfer to the bit and improved stability of the temperature at the point of contact with the work. Indeed, experiments have shown that an XS25 watt iron can be used for tasks where a 40 watt iron would normally have been required.

ANTEX Soldering Irons exhibit exceptionally low leakage currents & hence are suitable for use on Static Sensitive Devices. Sophisticated temperature controlled soldering units have recently been added to the ANTEX range.

TCSU1 Soldering Unit

ST4 Stand

SK5 Soldering Kit

Model XS

Model CS

Model C

TCSU-D Temperature-Controlled Soldering Unit

Model C
- 15 Watts. Available for 250, 220, 115, 100, 50 or 24 volts.

Model XS
- 25 Watts. Available for 240, 220, 115, 100, 50, 24 or 12 volts.

Model XS-BP
- 25 Watts. 240 volts, fitted with British Plug.

ST4 Stand
- To suit all irons.

SK5 Soldering Kit. Contains model CS 240v Iron, an ST4 Stand and solder.

SK6 Soldering Kit. Contains model XS240v Iron, an ST4 Stand and solder.

SK5-BP and SK6-BP Soldering Kits as above with British Plug.

Model CS
- 17 Watts. Available for 240, 220, 115, 100, 50, 24 or 12 volts.

Model CS-BP
- 17 Watts. 240 volts, fitted with British Plug.

TCSU1
- Very robust temperature controlled Soldering Unit, with a choice of 30 Watt (CSTC) or 40 Watt (XSTC) miniature irons. Range 65°C to 420°C. Accuracy 2%.

TCSU-D
Elegant Temperature Controlled Soldering Unit with 50 W Iron (XSD) and built around FERRANTI custom-made ULA. Range Ambient to 450°C. Accuracy $\pm 5^\circ\text{C}$. Zero crossing switching. Detachable sponge tray.

ANTEX Made in England
ANTEX (Electronics) Ltd. Telex: 45296
 Mayflower House, Plymouth, Devon. Tel: 0752 667377
 Please send literature, price list and my nearest stockist to:
 Name _____ Address _____ Telephone _____

Electronics behind the scenes at the



TELEVISION programmes pour into most homes for many hours of the day, and even the most unobservant must have noticed how fast-paced, complicated yet thoroughly professional it has become. The smooth running of television presentation is largely due to technical support, and it will be no great surprise that microelectronics and computer techniques are playing a greater part behind the scenes.

Many articles have been published describing technical developments in the distribution, transmission and reception of television, but very little on the behind-the-scenes studio and post-production support. I recently visited the BBC's Television Centre in London to discover some of the roles of modern electronics in television.

This article describes how digital electronics and microelectronics have become important factors in television production. All areas of production are benefitting from these developments, including computer controlled studio lighting, video editing, sound editing, graphics generation and special visual effects.

COMPUTERS IN NEWS

One of the greatest strengths of the microcomputer is in collecting, organising and distributing information, and in this application it has become one of the most powerful production aids, particularly in news and current affairs programmes. Television journalists can 'type' in news and feature items from terminals as remote as Glasgow and Plymouth, editors can edit the material and organise it to be displayed in any order and, finally, presenters can read it straight from a VDU when broadcasting. Any amendments, change of sequence or urgent items inserted can be done swiftly and smoothly, often during live transmissions.

Breakfast Television is a good example of successful 'new technology' production. The 2½ hour programme every weekday is the climax of a twenty-four hour cycle where up to one hundred feature scripts can be on store for any one show. The running order of the items is displayed to the presenters on a VDU and any script can be called up immediately and used directly on the Autocue. The system is centred on Hewlett-Packard computers with customised software. Gone are the days when piles of type-written paper were distributed hurriedly, often causing errors and mix-ups. Now presenters such as Frank Bough and Selena Scott can take a very relaxed approach, confident that the reliable system will not let them down.

The news-rooms are now silent save for the slight click of the key-board, compared with the noisy clatter of the old typewriters and consequently concentration is improved. The production team are convinced that the enormous amount of preparation for 2½ hours of live television could not be done using only paper. Of course, they do have some paper back-up, just in case.

MEMORY LIGHTING CONTROL

Microprocessor control for stage and studio lighting has been available for a number of years. A range of complex lighting effects can be set up from a control desk using faders (slider controls). The analogue position of each fader is digitised using a multiplexed analogue to digital converter in order to store the setting of each fader in memory. A large number of combinations can be stored depending on the size of the memory. See block diagram (Fig. 1).

Once the light settings have been stored, each pattern can be called from memory randomly or in any sequence. Information about the settings is sent through a serial link (to reduce long cable costs) to be decoded and to control the slave dimmer circuits which are triac-based to vary the intensity of the



The Sypher Sound Dubbing Suite with turntables and ¼" tape machines for sound effects

BBC

Chris Kelly

lamps. Automatically timed fades, both up and down, can be programmed with times from seconds to hours.

The speed at which lighting changes between scenes can be accomplished is a big advantage of this type of system. The BBC have a number of Rank Strand Modular Memory Systems (MMS) and the more recent Galaxy system which includes special effects lighting such as chase lighting, sound to light conversion, etc.

EDITING VIDEO

The technique of editing video tape is not as straightforward as say film or audio tape; simply splicing two sections of video tape can result in abrupt changes in the synchronisation signals causing momentary loss of vision. Early tape-splicing required great skill to avoid such problems. Now editing is done electronically. The whole process is simplified and permits greater precision by the use of a digital code known as 'time-code' (Fig. 2). This is a signal recorded onto the 'cue' track at the same time as video recording. Each frame of video is given a unique time reference so that editing electronically can be to an accuracy of 1/25 of a second.

The EBU (European Broadcasting Union) time-code standard gives the essential information of hours, minutes, seconds and frames from a daily reference time (10 a.m. is zero reference at the BBC). Other binary words (BWs) can be used to store information such as date, tape number and scene number.

The 'sync word' of 00111111111101 is cleverly designed so that the direction of the tape movement can be determined. A '1' followed by a '0' then twelve '1's is detected in the forward direction; two '0's followed by twelve '1's and the tape is being transported backwards. This is important for the electronics to know whether to read normal or reverse when the video tape recorder (VTR) is being shuttled back and forth to edit points.

The modulation is such that a transition occurs at the start of every bit period. If a second transition occurs within the bit



Control desk with time code visible on monitor screen

period then the bit is '1'; if no second transition occurs then the bit is '0'. Each time-code frame comprises 80 bits and at normal tape replay speeds we have 2000 bits per second, giving reference to the 25 frames per second. The time-code also has to be read at fast-forward and fast-reverse speeds so that edit points are quickly accessed.

A computer controlled editing machine is used to synchronise the running of two source VTR's (Fig. 3). A scene from VTR 1 is recorded onto a master VTR up to an edit point which has previously been specified and is stored in the memory of the controller. On approaching the edit point, VTR2 is run up and at the edit point the mixer switches to VTR2 as the source signal with full synchronisation over the edit. To achieve a flawless edit, the editing machine has to calculate the exact time to start VTR2 in order to run up and bring it into sync with the signal from VTR1 so that the last specified frame is reached from VTR1 precisely 1/25 of a second before the first specified frame from VTR2. This method can be used to quickly 'program' complex sequences with many changes from scene to scene and brief inserts. The



Control room interior of Video Tape Editing Suite with small vision and sound mixers

CONTROL DESK

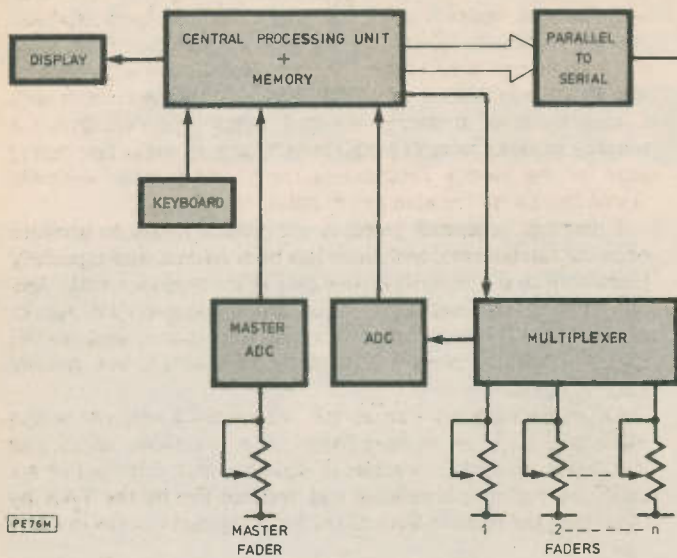

DIMMER CIRCUITS

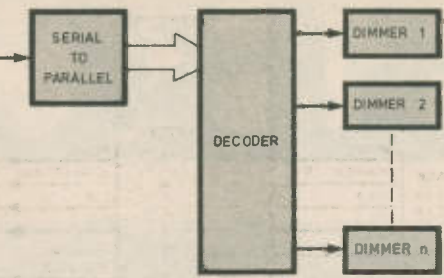

Fig. 1. Block diagram of a memory lighting system

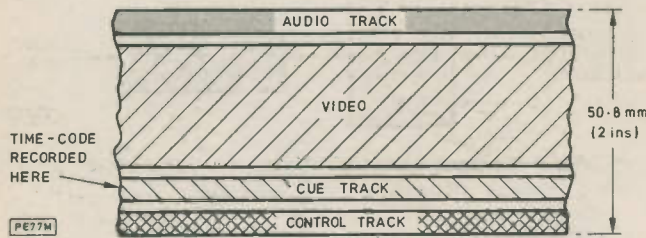

Fig. 2. Quadruplex video recording format

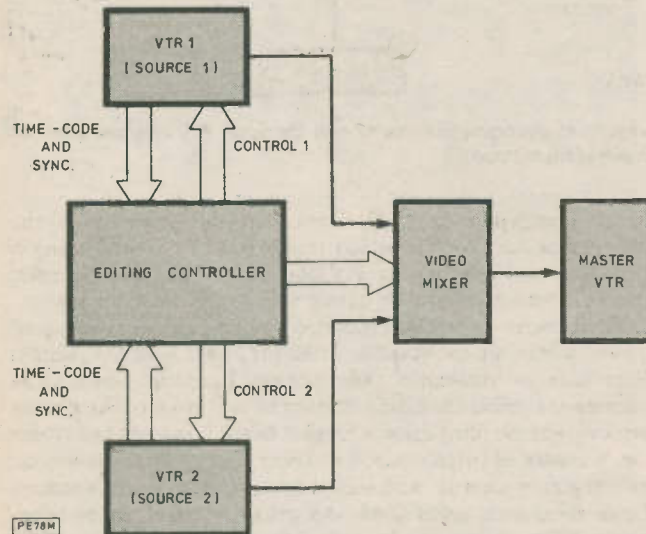

Fig. 3. Computer controlled editing

whole thing can be rehearsed any number of times to the producer's or director's satisfaction until the final recording is made. Fine adjustments can be made to achieve a desired effect simply by keying in new time-code edit points.

TELEVISION SOUND

The role of television sound is generally underrated because television is regarded as primarily visual. But next time you see a piece on television with no dialogue, turn the sound down and notice the loss of impact. Even relatively unimportant background noises and particularly background music adds considerably to the overall effect. During programme recording, the video information is recorded on a VTR along with the original sound channel. The video is edited for the best visual continuity, but if the sound was chopped about in exactly the same way it would exhibit unacceptably abrupt changes. For example, an audience laughing at the end of one scene would stop unnaturally at the cut to the next. To avoid this the audience laughter would be mixed or "laid over" into the next scene for smoother continuity.

To significantly speed up sound dubbing, the BBC have developed a technique called 'Sypher' which stands for Synchronised Post-dub Helical-scan and Eight-track Recorder. This utilises the same time-code facility as used for video editing (Fig. 4).

The original sound track is copied from the video tape onto track 6 of a multi-track sound recorder (MSR) along with the time-code which is layed on track 8. The VTR and MSR are run synchronously using the time-code to lock them together and the soundtrack may be rebalanced or music, commentary or sound effects (F/X) added at precise points using the time-code reference. This final sound mix is recorded onto track 5 of the MSR. When satisfactory, the new sound is dubbed back to the master video tape thus erasing the original sound track. Again, because of time-code, perfect voice and other sound synchronisation can be ensured. The use of Sypher significantly reduces the time needed for sound dubbing and, as with video, numerous rehearsals are possible before the programme makers commit themselves to a final recording. The BBC at Television Centre have two Sypher Suites and a third is being developed.

TELEVISION GRAPHICS

Even to the most casual viewer, television graphics are becoming increasingly computerised and used over a wide range of programmes from news and current affairs to providing the visual links between children's programmes. But did you know that the BBC clock does not exist in reality? A piece of

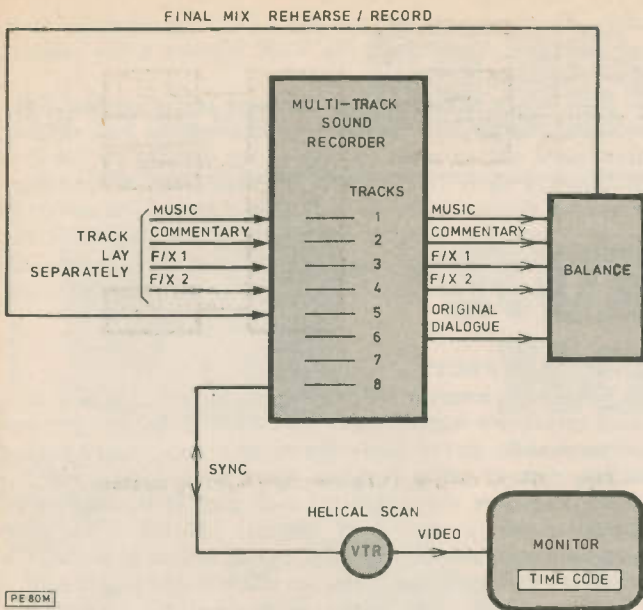
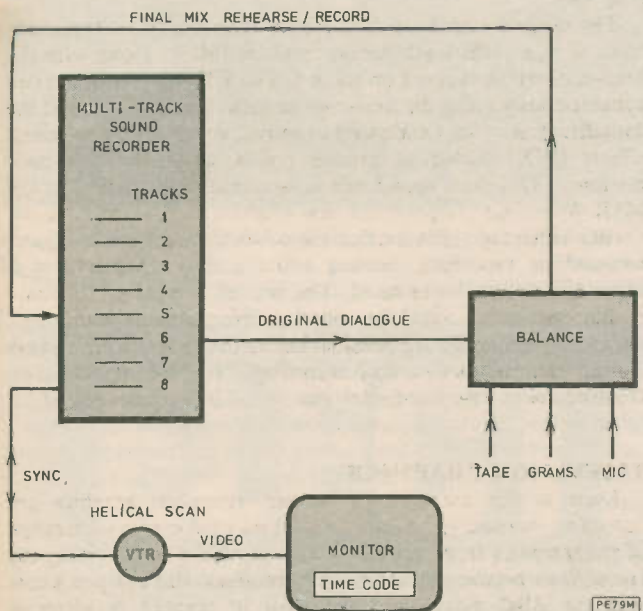

Fig. 4. Sypher editing. The simplest form of dub is to carry out a complete balance using the rehearsal/record facility. The original dialogue (track 6) is balanced with new material and recorded immediately onto track 5—the final mix.

When it is necessary to balance a large number of sources and maintain careful control of each one then track-laying is the recommended practice. Sound sources, reproduced from disc and tape machines, are routed by the sound supervisor for recording purposes, to MSR tracks 1 to 4 and, for example, identified as music, commentary, F/X1 and F/X2, depending on the type of programme. The new material may be recorded in any order; for instance, the music, followed by the commentary, then the effects—re-running the tapes each time but *spooling-on* between each recorded section. Alternatively, recording may proceed progressively in programme order, recording all new material onto the different tracks as required. Whichever method is used to lay the tracks, monitoring levels of each pre-recorded track may be adjusted separately (below).



hardware developed in-house is fed with precise time signals and generates the clock face and the new BBC logo. A close look at the second hand when it is moving between the horizontal and vertical reveals the tell-tale zig-zag of a computer generated line.

Development work takes place in the Computer Graphics Workshop which uses two VAX 11/750 computers each with 2 megabytes of memory. When I visited the department a number of tasks were in progress including an exploding pound sign for the Money Programme and research into Computer Aided Design for the planning of studio sets (Fig. 5).

Computer generated graphics are generally easy to produce once the fundamental technique has been refined, and especially lends itself to the analysis of raw data of the type seen with Election results. The computer makes calculations on the results entered via keyboard then drives video equipment such as the Quantel 7001 to present the results in a simple but visually striking manner.

Often background frames are pre-prepared and are stored away in a back-up memory (often on a Winchester disc). The bar-charts, pie-charts or tables of alpha-numeric information are called up during a broadcast and updated live by the VAX by modifying the relative sizes of the bars/segments or the order in

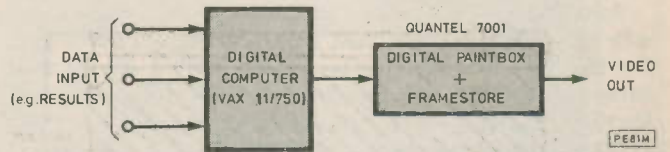

Fig. 5. Computer controlled graphics generation

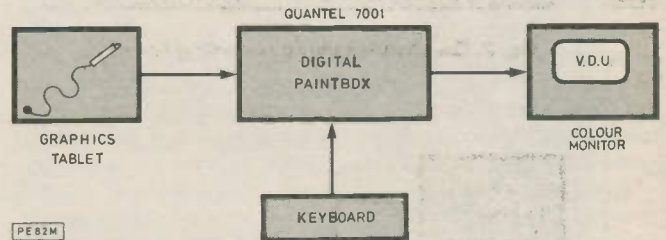

Fig. 6. Main components of the Quantel 7001 when used as a painting system

which results are declared. Sometimes the presenter of the programme can control which frame is to be viewed using a keyboard and referring to a VDU menu. This gives speedier results and a smoother flow during such hectic programmes.

Each frame or picture generated by computer is made up of 'pixels' which are the smallest definable points within a picture. Each pixel is associated with memory locations which store numbers to define the pixel's brightness and colour. The picture memory can be filled using a graphic tablet input and pen which can simulate an artist's pencil or brush. The operator paints on an imaginary canvass and sees the image on a monitor screen. Lines are drawn, areas filled with colour or parts can be selectively erased and modified until satisfactory (Fig. 6).

The image is displayed by the computer accessing the digital information for each pixel in turn, converting it into luminance and chrominance signals compatible with PAL, NTSC or RGB video standards. Repeated scanning of all the pixels a number of times per second displays a full picture on a monitor. Two systems are used by the BBC: Flair by Logica and Paintbox by Quantel (Breakfast Television). Fig. 7.

An alternative to drawing a complete image is to freeze live

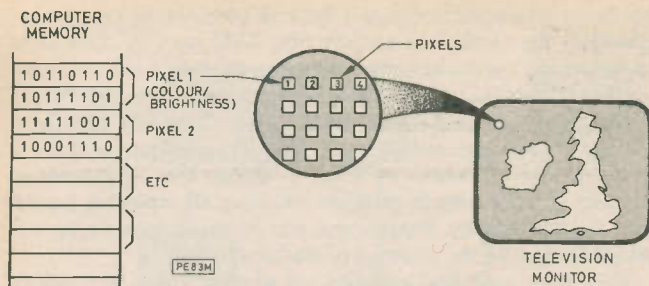

Fig. 7. Memory storage of colour/brightness information for each pixel

video images using very fast analogue to digital converters which 'digitise' the analogue signals. Once stored in memory, the information for each pixel can be modified by the artist using the graphic tablet and pen. The picture can be retouched for many special effects. Even separate parts of different pictures can be combined to make a composite image.

SPECIAL EFFECTS

Sophisticated special effects are possible by mixing live action with drawn backgrounds using a method called 'chroma-key'. For this effect the live action takes place in front of a coloured backcloth, normally blue. The blue part of the video signal from the television camera is blocked by an electronic switch sensitive to the blue part of the signal. The switch signal is then used to switch in the parts of an image from a digital framestore and when the separate signals from the camera and the framestore are combined the blue background appears to be filled in by the drawn picture on the final picture.

These are often referred to as 'glass shots' which is the associated technique used in the film industry where the live action is filmed through a large glass screen upon which an artist has painted the required background to match the foreground in colour and perspective (even though the glass is between the camera and live action!) But that is another story . . .

Great skill is required by the artist and television studio staff to match the foreground action and background images convincingly, but this technique had been used many times to create effects which otherwise would be prohibitively expensive. For example, a recent series on BBC1 called *Tripods* showed a scene where three youths walked through the ruined streets of Paris with a precariously crumpled Eiffel Tower in the distance.

CASTLES IN THE AIR

A new and exciting development in the Computer Graphics Department is the use of CAD (Computer Aided Design) software for studio set design. A program called MEDUSA by Cambridge Interactive Systems is run on one of the VAX computers which permits a designer to compile a complete set plan from components stored in a vast library. When finished, fully dimensioned drawings in third-angle projection are plotted and component lists printed for the set builders.

The computer can then be asked to display the view of the 'imaginary' set from any desired angle, which can be plotted in true three-dimensional perspective. This tool is of enormous help to a director who wishes to plan camera angles for complicated scenes which previously required scale models to be built to see if the camera angles are effective. The computer can generate a series of shots, providing a 3-D storyboard of how a scene can be developed.

Within minutes, a Georgian set (for instance) can be generated, pieced together on the high resolution VDU (win-

dows, doors, columns, etc) and then a 3-D image displayed from a selected angle, although the VAX requires a few minutes thinking time to do this.

Furthermore, designs of sets displayed as line drawings from any angle by the CAD system can be interfaced with a digital framestore and an artist can colour the drawing for use in a chroma-key shot. The potential for imaginative sets is enormous, yet the cost is low. So don't believe all that you see on the small screen. The banquet hall of a medieval manor, or the courtyard and towers of a fairy-tale castle, or the large futuristic sets in *Doctor Who* may look convincing but may not really exist at all.

DIGITAL EFFECTS

Television viewers are familiar with the visual effects now used extensively where images are shrunk to become pictures within pictures, moved around the screen or even rotated.

This type of effect is again based on first digitising the analogue picture signal, so that each pixel is represented by digital numbers stored in memory. If the controlling microprocessor assembles the picture information by placing the pixels in a different order, numerous effects can be produced.

For example, freeze frame is achieved by continuously reading the frame pixels in store, picture inversion is produced by reading the pixels from bottom right upwards instead of top left down. If every other pixel is read from memory and every other line assembled, the picture area on a normal screen will be reduced by a factor of four, repeating pixels and lines a number of times gives an artificial magnification. Recalculating reduction or enlargements for successive frames gives the effect of zooming in or out.



Sophisticated software is used to calculate the order of pixel reassembly to create spinning and tumbling effects. Most of these effects can be produced using moving images.

To operate in real-time, so that live action can continue throughout the effects, the analogue to digital conversions and digital to analogue conversions are made at extremely fast rates. The sampling rate along each line is at 700 samples per line to give sufficient resolution for broadcast quality. There are 575 active lines in the 625 line system and at 25 frames per second this gives $700 \times 575 \times 25$ which is over 10 million samples per second!

ACKNOWLEDGEMENTS

Sincere thanks to all at the BBC, particularly to Derek Robinson, Liaison Engineer.

all in your **JUNE** issue!

'RUR' HOBBY ROBOT

This new design is intended to form the basis of a mobile robot system that can be developed and expanded in a number of ways. The basic mobile unit carries a rack mounted c.p.u., rechargeable power source, tray and arm mounting facilities.

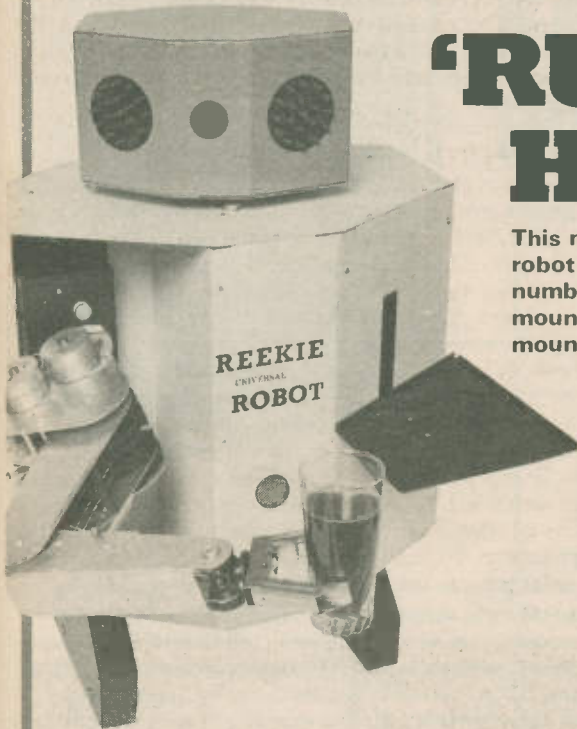

CBM 64 MUSIC KEYBOARD

A stylus keyboard, a proper conventional keyboard or a synthesiser keyboard can be added to the CBM 64 using our design. Thus enabling the excellent music facilities of the machine to be fully exploited.

modems

What is a modem? What does it look like? What can I do with it? How much does it cost? How does it work? How was it designed? How does it use the telephone system? What kind of databases can I access with it? What about microcomputer compatibility? Enough! Enough!!

The answers to all these questions can be found in a three part series which begins in the June issue. It will offer a wide insight into the expansive world of modems and open up new avenues of exploration into a world of privately and publicly accessible databases.

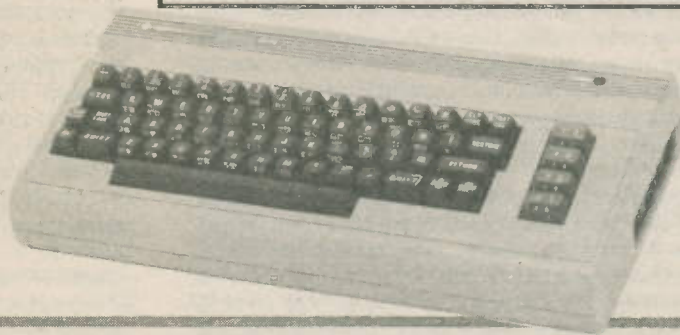

PRACTICAL

ELECTRONICS

ROBOTICS · MICROS · ELECTRONICS · INTERFACING
JUNE ISSUE ON SALE FRIDAY, MAY 3

CYLINDER THERMOSTAT MARK STUART

BY far the largest domestic use of fuel is for space heating and hot water. As fuel costs continue to rise the need for its economical use becomes more and more important.

In the majority of boiler type, gas or oil fired heating systems the control is by means of a simple timer and a single room thermostat. With this arrangement the only means of controlling the hot water temperature is by adjusting the boiler temperature. This has two bad side effects. One is that the necessary boiler temperature for good central heating performance is higher than the optimum hot water temperature for economy and safety. So the heat losses from the hot tank are unnecessarily high, and there is a danger of being scalded especially where children or old people are involved.

The second side effect is less obvious but can result in a considerable waste of fuel especially in summer when the boiler runs just to provide hot water. The waste is caused by boiler 'short cycling'. It occurs after the hot water has been heated to the correct temperature and the boiler is still switched on by the timer. The boiler thermostat operates to maintain the water in the boiler itself at the set temperature even though no heat is required by the hot water. During this time the boiler core repeatedly cools and is re-heated by short bursts of boiler firing. This energy is totally wasted. The waste continues until eventually the timer switches off the boiler at the end of the set period.

Hot water cylinder thermostats using bi-metal sensing elements are available but usually they have only a single pair of contacts which open when the set temperature is reached. This limits their flexibility especially when they are to be connected to existing systems.

With all of these considerations in mind an electronic thermostat was developed.

To allow even greater fuel savings an additional feature of variable 'offset' has been introduced. This allows the user to determine how far the hot water temperature must fall below the set temperature before the boiler is turned on. To understand this more fully imagine a cylinder full of cold water being heated. The thermostat will keep the boiler turned on until the indicated set temperature is reached. At this point the thermostat will switch off the boiler until the water in the hot water cylinder falls below the indicated set temperature by the amount set on the offset control. The boiler will then be switched on again until the set temperature is reached. The advantage of this system is that the boiler is only turned on when there has been a significant drop in the hot water temperature. The boiler therefore fires less frequently and when it does fire it runs for a substantial amount of time. This maximises the efficiency of the boiler, and because of the less frequent firing reduces wear and tear on the boiler solenoid and minimises the noise level.

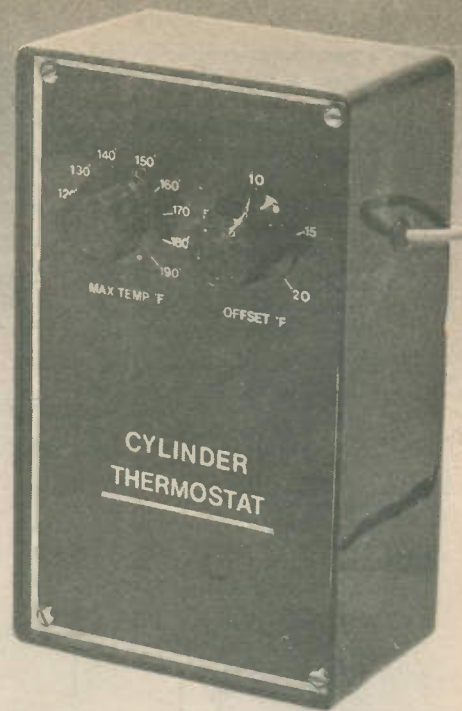

CIRCUIT

The circuit diagram of the thermostat is shown in Fig 1. The temperature is sensed by IC3 which produces an output current proportional to the absolute ($^{\circ}\text{K}$) temperature level. R1 sets this current to $1\mu\text{A}$ per $^{\circ}\text{K}$ which corresponds to approximately $300\mu\text{A}$ at room temperature. This sensor current generates approximately 3 volts across the series combination of VR3, R2 and R3 at room temperature. R4 does not have an influence because TR1 is turned off. The sensor voltage passes to pin 2 of the IC2 which is connected as a voltage comparator. The voltage is compared with a reference voltage from the 'set temperature' control VR2. If the reference voltage is above the sensor voltage the output of IC2 pin 6 is high. This high voltage output turns on TR3 which operates the relay RLA. When the sensor temperature increases the sensor voltage will rise until it exceeds the reference voltage. At this point the output of IC2 will switch from high to low. TR3 will be turned off and the relay released. TR2 will be turned on via R7, connecting the 5 volt supply to the offset control VR1. A proportion of the voltage across VR1 is tapped off by the slider and fed to the base of TR1 which is connected as an emitter follower, it has a gain of 1 combined with a high input impedance and a low output impedance. This ensures that the voltage on VR1 is not influenced by the loading due to R4. From TR1 emitter the offset voltage passes to R4 and R3. The result is that a small voltage is impressed upon R3. This voltage depends on the setting of the offset control and is added to the sensor voltage across VR3 and R2. The effect of this is to artificially raise the sensor voltage so that the temperature has further to fall before the relay can be operated. In this way the offset effect is introduced. With VR1 set fully clockwise a larger voltage appears across R3 and so the temperature has further to fall. When VR1 is set fully anti-clockwise only a very small voltage appears across R3 and the offset is minimum.

The circuit is powered by a p.c.b. mounted transformer which provides 12V for IC2 and the relay. A stable 5V supply rail for the sensing and reference circuits is provided by the voltage regulator, IC1.

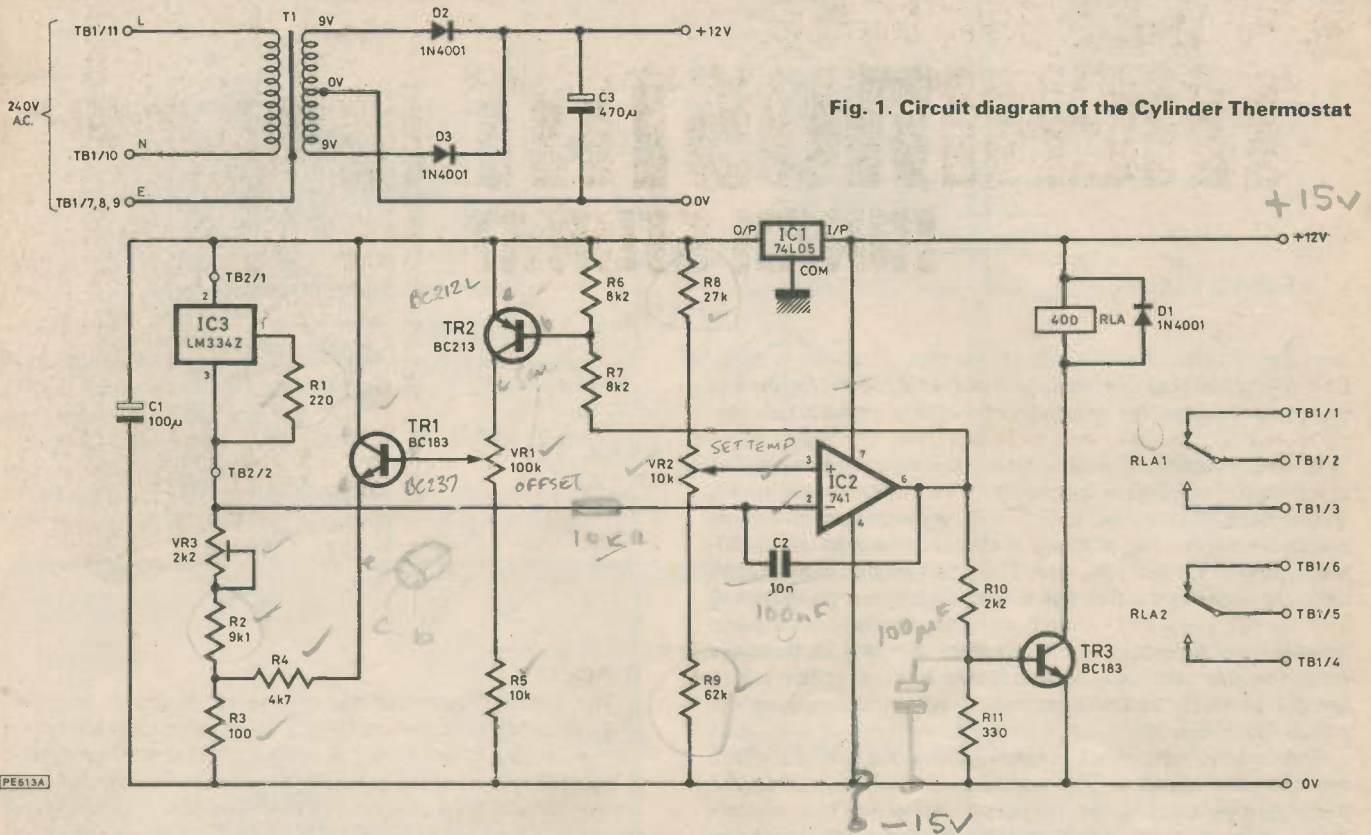

Fig. 1. Circuit diagram of the Cylinder Thermostat

CONSTRUCTION

The circuit is constructed on a single printed circuit board. It is a good idea to use the bare board as a template to drill its mounting holes in the case and the holes for the spindles of VR1 and VR2 in the case lid. This will make final assembly much easier.

A component layout is shown in Fig. 2. Mount all of the small components first. Make sure that all of the polarised components are the right way round and that the transistors and IC1 do not get mixed up. VR1 and VR2 are mounted on the track side of the board so that their spindles pass through to the component side. The tags need bending forward carefully by 90° so that they fit into the board. Finally mount the relay and transformer. The transformer tags may need scraping carefully before soldering to ensure that excess varnish is removed.

When the board assembly is complete check for dry joints and set VR3 to mid setting.

Next the sensor should be assembled as shown in Fig. 3. Bend up the centre lead for connection to R1 and connect the screened cable as shown. The sensor can be left in this form ready for testing, but should be encapsulated in epoxy resin before final installation. Fig. 4 shows one possible way of making the sensor. Note that the flat face of IC3 should be in close contact with the aluminium sheet to ensure good heat transfer. The length of the lead to the sensor can be any length within reason. The sensor will tolerate at least 1kohm of lead resistance without introducing any significant errors.

TESTING

Connect the sensor to the main circuit board, and connect the mains supply to pins 11 (live), 10 (neutral), and 9 (earth). With the sensor at room temperature the relay should

remain operated for all settings of VR2. Set VR2 to minimum and heat the sensor by holding a soldering iron close to it (but not touching). When the temperature of the transducer rises to the set temperature the relay should release. Quickly turn VR2 fully clockwise and check that the relay again operates. Continue heating the sensor until the new higher set temperature is reached and the relay again releases. The operation of VR1 is not easy to test by this method because the temperature of the sensor needs to be held fairly steady. If the tests carried out so far are successful the sensor should now be encapsulated in epoxy resin.

When the sensor's encapsulation has set, immerse it in a jam jar of hot water. Adjust the water temperature so that the relay releases with VR2 set to approximately mid position. Turn VR2 up and down and note the 'backlash' between the points at which the relay operates and releases. Check that the 'backlash' increases as VR1 is advanced from minimum to maximum. If a multimeter is available check that the output from IC1 is 5V, and that there is between 12 and 16 volts across C3. Check with an ohmmeter or continuity tester for correct operation of the relay contacts RLA1 and RLA2 on terminals 1 to 6.

CALIBRATION

The simplest way to calibrate the thermostat is to immerse the sensor in water which is then slowly heated by adding small amounts of very hot water and stirring well. A standard thermometer should be stood in the water to give accurate temperature readings. Start with water at 100°F and set VR1 and VR2 fully anticlockwise. Turn VR3 until the relay operates and then turn it back carefully until the relay just releases. Fix VR3 in position with a small dab of glue and calibration is complete.

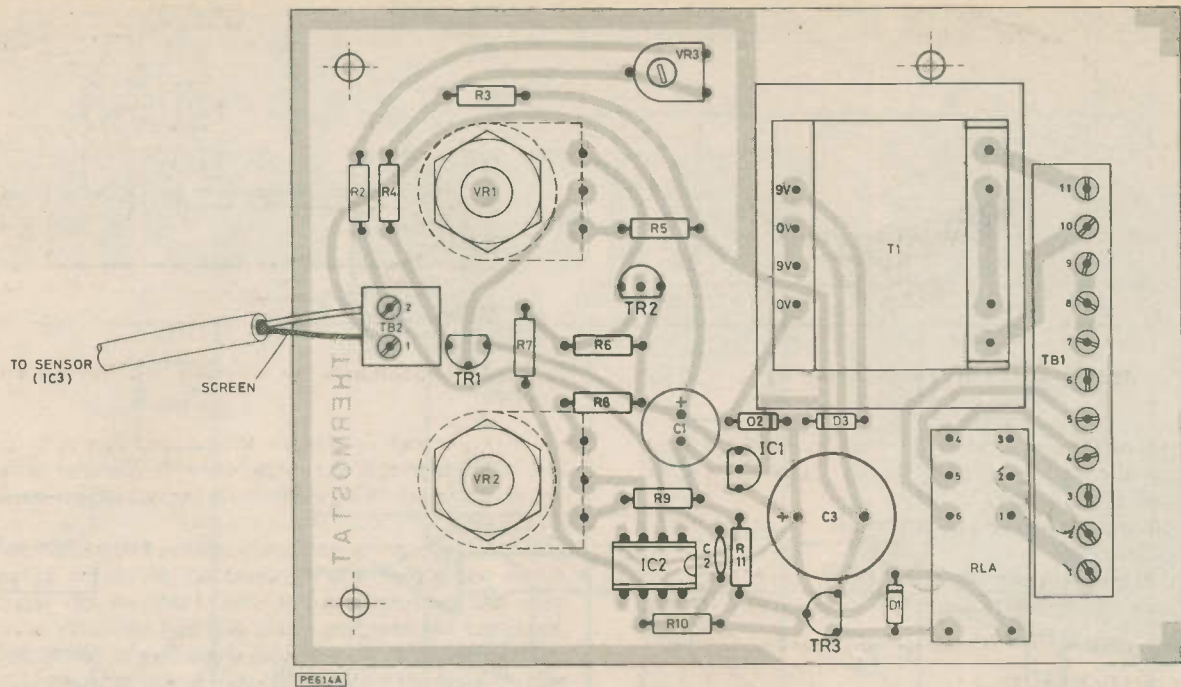

Fig. 2. Component layout of the p.c.b.

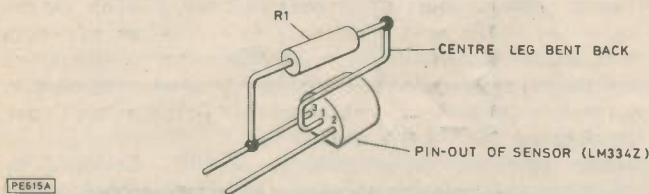

Fig. 3. Sensor assembly

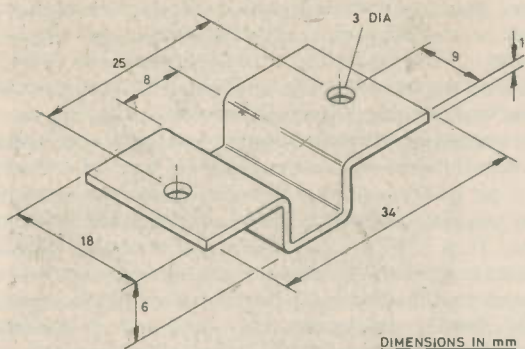
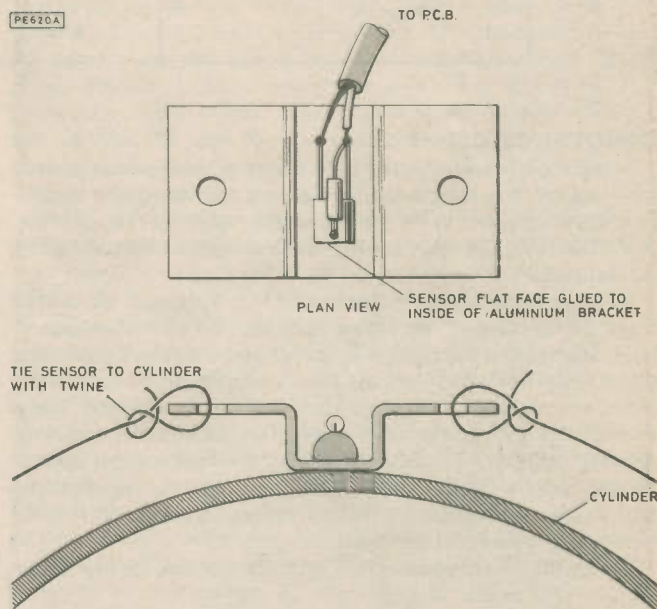

Fig. 4. Sensor bracket assembly and mounting details



The scales for VR1 and VR2 are shown in the photograph. These can be copied or traced onto the case as required.

Finally mount the p.c.b. in the bottom of the case using long screws with 3 nuts each. Space the board from the bottom of the case so that the spindles of VR1 VR2 pass far enough through the top panel to fit the knobs.

The setting of the offset control depends upon the requirements of the user. The larger the offset the more efficient the system will be. At maximum offset the temperature fluctuation of the hot water may be too great. It may be better to increase the set temperature so that even at maximum offset

the temperature does not fall below an acceptable level. The final settings are up to the user—it is easy to experiment.

INSTALLATION

The connection of the thermostat depends very much upon the existing arrangements for control of the heating and hot water system. For full control it is essential to fit a motorised valve in the hot water primary circuit. Without a motorised valve the central heating demand will over-rule the hot water thermostat during the time that the heating is on. However, significant savings can still be made because

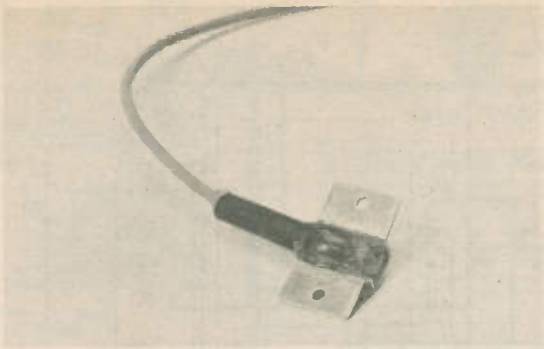

Photograph of the sensor assembly

the boiler will be turned off when the heating thermostat and the hot water thermostat are both satisfied. Also the heating is off for much of the summer.

Fig. 5 shows the simplest arrangement for a system without a cylinder valve.

The type of programmer normally fitted in simple systems has two pairs of contacts. One pair close when only hot

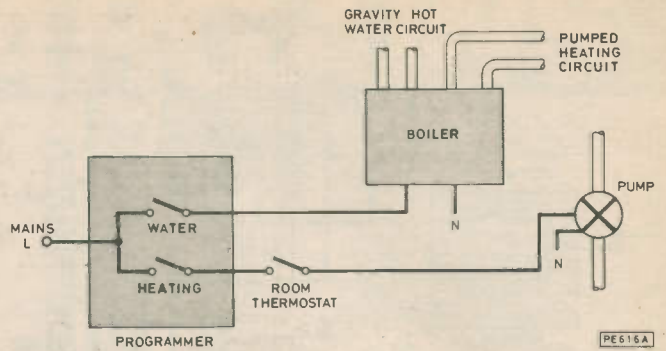

Fig. 5. Arrangement for a system without a cylinder valve

water is required, both pairs close when heating is required. The room thermostat usually controls just the pump and leaves the boiler idling even when the set room temperature is reached.

The cylinder thermostat is connected as shown in Fig. 6. When hot water only is selected the boiler solenoid is energised via terminals 2 and 3 of the cylinder thermostat. When the set temperature is reached the relay is released and terminals 2 and 3 separate. The boiler is therefore switched off until the thermostat senses that the water has cooled and again operates the relay.

When 'heating' is selected the boiler solenoid receives power either via contacts 2 and 3 when the cylinder thermostat demands heat, or via contact 1 and 2 when the hot water set temperature has been reached. When the room temperature is sufficient the room thermostat contacts open and the boiler solenoid can no longer be powered via contact number 1. Thus when heating and hot water demands are satisfied the boiler is shut down.

COMPONENTS . . .

Resistors

R1	220	1%
R2	9k1	1%
R3	100	
R4	4k7	
R5	10k	
R6,R7	8k2 (2 off)	
R8	27k	1%
R9	62k	1%
R10	2k2	
R11	330	
VR1	100k linear pot—long spindle	
VR2	10k linear pot—long spindle	
VR3	2k2 min horizontal preset	

All resistors $\frac{1}{4}$ W carbon film 5% unless otherwise stated

Capacitors

C1	100 μ 16V radial electrolytic
C2	10n ceramic
C3	470 μ 25V radial electrolytic

Semiconductors

D1,D2,D3	1N4001 (3 off)
TR1,TR3	BC183 (2 off)
TR2	BC213
IC1	78L05
IC2	741
IC3	LM334Z

Miscellaneous

T1 0-9-0-9 6VA p.c.b. mounting transformer
 RLA 12V 400 d.p.c.o. p.c.b. mounting relay—contacts 1A at 240V

Case approx 160x96x55mm

P.c.b.

Aluminium approx 50x25mm for probe

P.c.b. Type terminal blocks: 3 way (3), 2 way (2) knobs, screws, nuts, grommets, screened wire

Constructor's Note

The complete kit, including the p.c.b., is available for £21.77 and the p.c.b. is available separately for £3.98. Please enclose 60p for p&p. **Magenta Electronics Ltd.**, 135 Hunter Street, Burton-on-Trent, Staffs DE14 2ST (0283 65435).

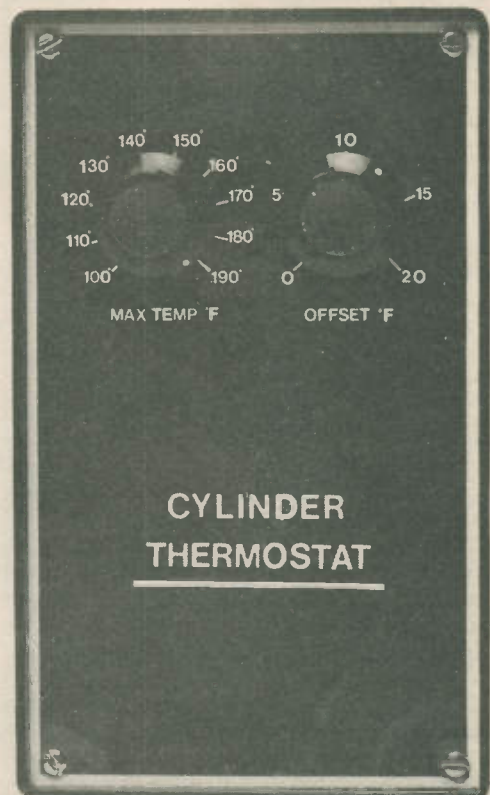

Front-panel legend

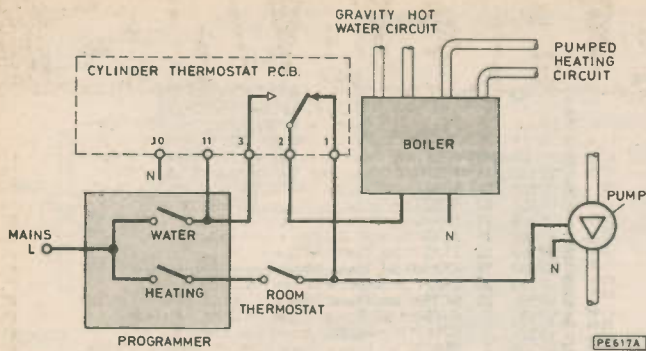

Fig. 6. Cylinder thermostat connection

This simple arrangement makes a tremendous improvement over the existing control system. It is particularly good when the heating demand is light during spring, summer and autumn. Whilst no claims are being made it is obvious that fuel will be saved whenever the boiler is prevented from idling or short cycling. If only 5% of fuel is saved the thermostat will be paid for quite quickly, and there will be the additional benefits of less noise, and less wear on the boiler.

The one disadvantage of this simple arrangement is that the boiler will continue to heat the water when the room thermostat is closed even if the cylinder thermostat is satisfied. To overcome this a motorised valve can be fitted to the hot water cylinder primary circuit. Fig. 7 shows the necessary connections. Some motorised valves have an auxiliary contact which can be wired to power the boiler solenoid only when the valve is open. This function is already provided by one of the sets of relay contacts in Fig. 7, but the valve auxiliary contacts could be used instead.

The final system shown in Fig. 8 is for use with a 'pumped primary' installation. In this type of system the boiler has

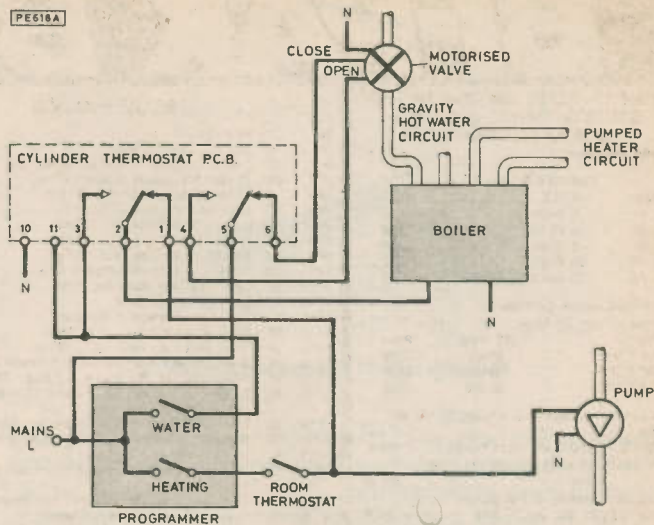

Fig. 7. Motorised valve connection

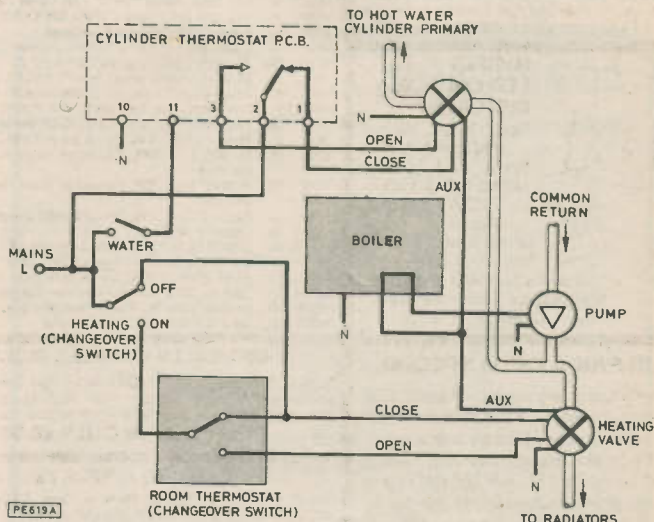
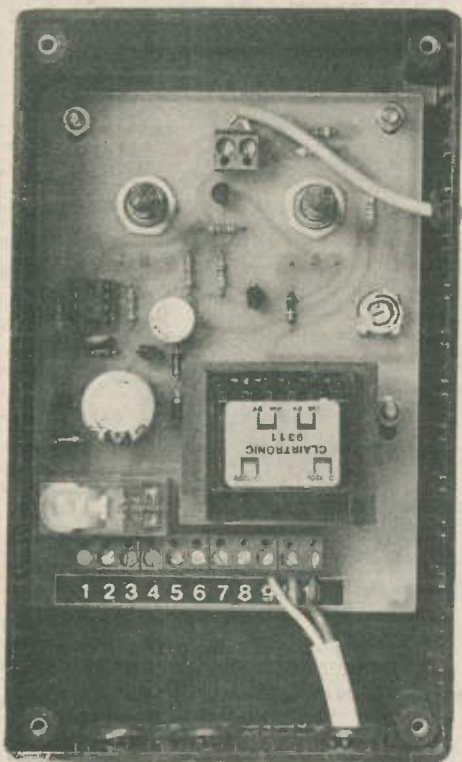

Fig. 8. Pumped primary installation



Internal view

only two water connections and the pump must be running whenever the boiler is turned on.

Modern low water content gas boilers must be used with a pumped primary system and are capable of very high fuel efficiency. In this installation two motorised valves are used, one for heating and one for hot water, each controlled by its own thermostat. The auxiliary contacts on the valve switch power on to the boiler whenever either or both of them are open.

Most domestic installations are of the type shown in Fig. 6, however there are many ways of connecting the various components of a central heating/hot water system and so it is impossible to cover all options here. The circuits shown should give some ideas upon which to build.

Always remember that the internal circuits of a boiler connect essential safety components and must never be tampered with.

Flues, air vents, and expansion pipes must never be tampered with. If the plumbing gives rise to any doubts there are a lot of good do it yourself heating manuals available. Some of them also give advice on 'electrics' but this aspect of heating control is often, sadly, given little attention. ★

BI-PAK BARGAINS

HIGH QUALITY MODULES FOR STEREO, MONO & OTHER AUDIO EQUIPMENT

O/No.	POWER R.M.S.	MAX SUP. VOLTAGE	PRICE
AL 30A	10 Watts	30V	£4.95
AL 60	25 Watts	30-50V	£5.92
AL 80	35 Watts	40-60V	£8.75
AL 120	50 Watts	50-70V	£15.22
AL 250	125 Watts	50-80V	£20.60

Stabilised Power Supplies — Output current 2.5 Amps

O/No.	AC Input	Price
SPM 120/45	40-48V	£8.05
SPM 120/55	50-55V	£8.05
SPM 120/65	60-65V	£8.05

Mono Pre-Amplifiers — Operating Vtg. 40-65V

O/No.	Price
MM 100 Suitable for Disco Mixer	£14.75
MM 100G Suitable for Guitar Pre-AMP Mixer	£14.75

Magnetic Cartridge Pre-Amplifier
O/No. MPA30 Sup Vtg. 20-30V. Price **£4.29**
The PA207 is a high quality pre-amplifier unit which features full range tone controls and an input switch. It is designed to drive power amplifiers ranging from the AL60 to the AL250.
Order No. PA207. **£18.50**

Full Specifications and Data available on request. Please send self-addressed envelope.

HYBRID LED COLOUR DISPLAYS

Red, Green, Yellow
— .3/.5/.6 inch Mixed
types and colours
NUMERIC & OVER-
FLOW Common
Anode/Cathode.
GaAsP/GaP. Brand
New. Full Data incl.

10 pieces (our mix) ... **£4.00**
Normal Retail Value Over **£10.00**
Order No. VP58

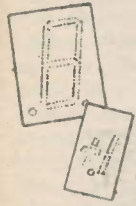

VALUE PACKS

Pak No	Qty	Description	Price
VP1	300	Assorted Resistors Mixed Types	£1.00
VP2	300	Carbon Resistors 1/4-1/2 Watt Pre-Formed	£1.00
VP3	200	1/2 Watt Min Carbon Resistors Mixed	£1.00
VP4	150	1/2 Watt Resistors 100 ohm-1M Mixed	£1.00
VP5	200	Assorted Capacitors All Types	£1.00
VP6	200	Ceramic Caps Miniature - Mixed	£1.00
VP7	100	Mixed Ceramic Discs. 1pf - 56pf	£1.00
VP8	100	Mixed Ceramic Discs. 89pf - 015pf	£1.00
VP9	100	Assorted Polyester/Polystyrene Caps	£1.00
VP10	60	C280 Type Caps Metal Foil Mixed	£1.00
VP11	50	Electrolytics - All Sorts	£1.00
VP12	60	Bead Type Polystyrene Min Caps	£1.00
VP13	50	Silver Mica Caps Ass. 56pf - 150pf	£1.00
VP14	50	Silver Mica Caps Ass. 180pf - 4700pf	£1.00
VP15	25	01uF 250V Min. layer metallised Polyester Capacitors	£1.00
VP16	50	Wirewound Res. 9W (avg) Ass. 1 ohm - 12K	£1.00
VP17	50	Metres PVC Covered Single Strand Wire Mixed Colours	£1.00
VP18	30	Metres PVC Covered Multi Strand Wire Mixed Colours	£1.00
VP19	40	Assorted Pencil/Multi Strand Hook-Up Wire Mixed	£1.00
VP20	6	Rocker Switches 5 Amp 240v	£1.00
VP21	15	Zin. high bright RED LEDs in plastic encapsulation-Large area light source	£1.00
VP22	200	Sq. Inches Total. Copper Clad Board Mixed Sizes	£1.00
VP23	20	Assorted Slider Pots. Mixed Values	£1.00
VP24	10	Slider Pots. 40 mm 22K 5 x Log 5 x Lin	£1.00
VP25	10	Slider Pots. 40 mm 47K 5 x Log 5 x Lin	£1.00
VP26	15	Small .125" Red LEDs	£1.00
VP27	15	Large .2" Red LEDs	£1.00
VP28	30	Rectangular .2" RED LED'S	£1.00
VP29	30	Ass. Zener Diodes 250mW - 2W Mixed Vtts. Coded	£1.00
VP30	10	Ass. 10W Zener Diodes Mixed Vtts. Coded	£1.00
VP31	10	5 Amp SCR'S TO-66 50-400 Coded	£1.00
VP32	20	3 Amp SCR'S TO-66 Up To 400v Uncoded	£1.00
VP33	200	Sil. Diodes Switching Like IN4148 DO-35	£1.00
VP34	200	Sil. Diodes Gen. Purpose Like OA200/BAX13/16	£1.00
VP35	50	1 Amp IN4000 Series Sil. Diodes Uncoded All Good	£1.00
VP37	8	Black Instrument Type Knobs With Pointer 1/4" Std	£1.00
VP42	10	Black Heatsinks To Fit TO-3, TO-220 Ready Drilled	£1.00
VP43	4	Power-Fin Heatsinks 2 x 10-3 2 x TO-66 Size	£1.00
VP45	50	BC107/8 Type NPN Transistors Good Gen. Purpose Uncoded	£1.00
VP46	50	BC177/8 Type PNP Transistors Good Gen. Purpose Uncoded	£1.00
VP47	10	Silicon Power Trans. Similar 2N3055 Uncoded	£1.00
VP48	10	Precision Resistors. 2-1% tol.	£1.00
VP49	40	1N4002 Sil. Rects. 1A 100v preformed pitch	£1.00
VP42	4	40A Power Rectifiers Silicon 7048 300PIV	£1.00
VP43	5	1B187 12KV Sil. Diodes in carriers 2.5mA	£1.00
VP44	4	100K 1in. Multi-turn pots. ideal vari. cap tuning	£1.00
VP45	10	Assorted pots. inc. Dual & Switched types	£1.00
VP46	25	Solid Tantalum Caps. Mixed Values	£1.00

TRANSISTOR PACKS

VP150	20	BC183B Sil. Trans. NPN 30v 200mA Hfe240+ TO92	£1.00
VP151	25	BC171B Sil. Trans. NPN 45v 100mA Hfe240+ TO92	£1.00
VP152	15	T1S90 Sil. Trans. NPN 40v 400mA Hfe100+ TO92	£1.00
VP153	15	T1S91 Sil. Trans. PNP 40v 400mA Hfe100+ TO92	£1.00
VP154	15	MPSA56 Sil. Trans. PNP 40v 800mA Hfe50+ TO92	£1.00
VP155	20	BF595 Sil. Trans. NPN eqvt. BF184 H.F. TO92	£1.00
VP156	20	BF495 Sil. Trans. NPN eqvt. BF173 H.F. TO92	£1.00
VP157	15	ZTX500 Series Sil. Trans. PNP Plastic	£1.00
VP158	15	ZTX107 Sil. Trans. NPN eqvt. BC107 Plastic	£1.00
VP159	15	ZTX108 Sil. Trans. NPN eqvt. BC108 Plastic	£1.00
VP160	20	E5024 Sil. Trans. PNP eqvt. BC214L TO92	£1.00
VP161	25	BC183 Sil. Trans. NPN 30v 200mA TO92	£1.00
VP162	5	SJE5451 Sil. Power Trans. NPN 80v 4A Hfe20+	£1.00
VP163	2	NPN/PNP pairs Sil. Power Trans. like SJE5451	£1.00
VP164	4	2N6289 Sil. Power Trans. NPN 40v 40w 7A Hfe30+	£1.00
VP165	6	BFT33 NPN Sil. Trans. 80v 5A Hfe50-200 TO39	£1.00
VP166	5	BFT34 NPN Sil. Trans. 100v 5A Hfe50-200 TO39	£1.00
VP167	1	BUY69C NPN TO3 VCB 500 10A 100w Hfe15+	£1.00
VP168	10	BC478 eqvt. BCY71 PNP Sil. Trans. TO18	£1.00
VP169	10	BXS21 eqvt. BC394 NPN Sil. Trans. 80v 50mA TO18	£1.00
VP170	10	Assorted Power Trans. NPN/PNP Coded & Data	£1.00
VP171	10	BF355 NPN TO-39 Sil. Trans. eqvt. BF258 225v 100mA	£1.00
VP172	10	SM1502 PNP TO39 Sil. Trans. 100v 100mA Hfe100+	£1.00

TRANSISTORS

100 Silicon NPN Transistors. All Perfect. Coded Mixed. Types With Data And Eqvt. Sheet No Rejects. Fantastic Value. O/No. VP38	£3.00	100 Silicon PNP Transistors. All Perfect. Coded. Mixed. Types With Data and Eqvt. Sheet. No Rejects. Real Value. O/No. VP39	£3.00
--	--------------	---	--------------

The best known Power Transmitter in the world 2N3055 NPN 115W. Our Bi-Pak Special Offer Price.
10 off 50 off 100 off
£3.50 £16.00 £30.00

BD312 COMPLIMENTARY PNP POWER TRANSISTORS TO 2N3055. Equivalent M2955 BD312 TO3. Special Price **£0.70** each. 10 off **£6.50**

SEMICONDUCTORS FROM AROUND THE WORLD

100 A collection of Transistors, Diodes, Rectifiers & Bridges, SCR's, Triacs, I.C.'s & Opto's all of which are current every day useable devices. Guaranteed Value Over £10 Normal Retail Price. Data etc. in every pack. Order No. VP56
Our Price £4.00

TRANSISTOR CLEARANCE

100 All Sorts Transistors. A mixed bag NPN-PNP Silicon & Germ. Mainly Uncoded You To Sort Pack includes instructions for making Simple Transistor Tester, Super Value.
Order No. VP60. **£1.00**

150 De-soldered Silicon Transistors from boards 10mm leads all good. O/No. VP173 **£1.00**

OPTICALLY COUPLED MODULES

1 pair SD1/131 Consisting 1 x LS600 Silicon Light Sensor & 1x Matched Gallium Arsenide Light Source - Type TIL23, on ready mounted fibre glass board. Including Data. Ideal Alarm projects etc. O/No. VP147.

BI-PAK Price ONLY £0.60 pr.

LED DISPLAYS

VP130	6	RED 7 Seg. CC 14mm x 7.5mm ROP FND353	£2.00
VP131	4	GREEN 7 Seg. CA 6' LDP XAN6520	£2.00
VP132	5	RED 7 Seg. CC 6' LDP XAN6940	£2.00
VP133	6	RED Over-flow 6' 3 x CA 3 x CC 6630/50	£2.00
VP134	5	GREEN Over-flow 6' 6' CA XAN6530	£2.00
VP135	5	RED 7 Seg. CA 3' XAN3061	£2.00
VP136	3	DUAL RED 7 Seg. 5' CA DL527 DPR	£2.00
VP137	3	DUAL RED 7 Seg. 51' CA DL727 DPR	£2.00
VP138	20	Assorted LED Displays - Our mix with Data	£5.00

RDP = Right Hand Decimal Point CC = Common Cathode
LDP = Left Hand Decimal Point CA = Common Anode

DC-DC POWER SUPPLY

DC to DC adapter. Plugs into car cigar lighter aperture. Output 3, 4.5, 6, 7.5, 9, 12V @ 800mA. Has universal output spider plug, also 9V battery snap and polarity reversing facility.
O/No. VP119/138 **£2.45**

HIGH PASS FILTER/SUPPRESSOR

CB/TV. High pass filter. Reduces unwanted signals picked up by antenna. Dims: 45 x 25 x 17mm.
O/No. VP 115 **45p**

Designed to reduce harmonics on the VHS and TV band. Cut-off frequency: 30MHz. S.V.W.R.: Less than 1.2 to 1. Insertion loss: -0.2dB @ 27MHz. Impedance: 50 ohms. Dims: 80 x 55 x 40mm.
O/No. VP 116 **£2.75**

LOW PASS FILTER



IC BARGAINS

40 Assorted TTL CMOS INTEGRATED CIRCUITS 74 Series & CD4000 Series - All new Gates, Flip-Flops - MSI etc. GREAT VALUE-Data Book & Sheets included. 40 Pieces (Our Mix) **£4.00** O/No. VP40

TECASBOTY

THE ELECTRONIC COMPONENTS AND SEMICONDUCTOR BARGAIN OF THE YEAR!

This collection of Components and Semiconductors for the hobbyist is probably the most value-packed selection ever offered, it consists of Resistors, carbon and wirewound of various values. Capacitors: All types, sorts and sizes including electrolytics, Potentiometers - single, dual, slider and preset. Switches, Fuses, Heatsinks, Wire, P.C.B. Board, Plugs, Sockets etc., PLUS a selection of Semiconductors for everyday use in popular Hobby Projects. These include: SCR's, Diodes, Rectifiers, Triacs & Bridges as well as a first class mix of Transistors and I.C.'s. In all, we estimate the value of this in current retail catalogues to be over £25! So, help yourself to a great surprise and order a Box TODAY - ONLY at BI-PAK. Remember, stocks are limited so hurry! You can call us on 0920 3182/3442 and order with your Barclaycard or Access Card - 24hr Answerphone Service Nowhere. Order No. VP 85.

just **£7.00**

SILICON BRIDGE RECTIFIERS

Comprising 4 x 1 1/2 amp rectifiers mounted on PCB.

VRM - 150 vits IFM - 1.5 Amps Size: 1 inch square
10 off **£1.00**

50 off **£4.50**
100 off **£7.50**
Order No. As:4R1 B Rect.

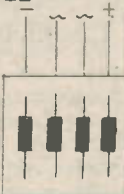

SIREN ALARM MODULE

American Police type sreamer powered from any 12 volt supply into 4 or 8 ohm speaker. Ideal for car burglar alarm, freezer breakdown and other security purposes.
Order No. BP124

POWER SUPPLY OUR PRICE £3.75

Power supply fits directly into 13 amp socket. Fused for safety. Polarity reversing socket. Voltage switch. Lead with multi plug input - 240v AC 50Hz Output - 3 4.5 6 7.5 9 & 12v DC. Rating 300ma MW88/137

(LEARN A LINGO) PILLOW SPEAKER

Slim under pillow unit. 80ohms 2" speaker. 1.5m lead with 3.5mm mono jack plug. Black. Dims: 65(dia) x 17mm. O/No. VP 88 **£1.25**

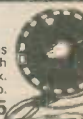

REGULATED VARIABLE Stabilised POWER SUPPLY

Variable from 2-30 volts and 0-2 amps Kit includes - 1 - VPS30 Module 1 - 25 volt 2 amp transformer. 1 - 0.50v 2 Panel Meter. 1 - 0-2 amp 2 Panel Meter. 1 - 470 ohm wirewound potentiometer. 1 - 4K7 ohm wirewound potentiometer. Wiring Diagram included. Order No. VPS30 KIT **£20**

MINIATURE FM TRANSMITTER

Freq: 95-106MHz. Range: 1/4 mile Size: 45 x 20mm. Add: 9v batt. Not licenced in U.K. **ONLY £5.50**
Ideal for: 007-M15-FBI-CIA-KGB etc. VP 128

INTRUSION ALARM

The DOOR BIRD DB 2000 alerts you before your door is opened. Just hang on the inside door knob - alarm is activated as soon as the outside door knob is touched.
ONLY £3.95



MW398 NI-CAD CHARGER

Universal Ni-Cad battery charger. All plastic case with lift up lid Charge/Test switch. LED indicators at each of the five charging points.

Charges -	Power -
PP3 (9V)	220-240V AC
U12 (1.5V penlite)	Dims -
U11 (1.5V "C")	210 x 100 x 50mm
U2 (1.5V "D")	£7.50

BI-PAK

Send your orders to Dept PE5 BI-PAK PO BOX 6 WARE, HERTS
SHOP AT 3 BALDOCK ST. WARE, HERTS.
TERMS CASH WITH ORDER, SAME DAY DESPATCH, ACCESS, BARCLAYCARD ALSO ACCEPTED. TEL (0920) 3182, GIRO 388 7006
ADD 15% VAT AND £1.00 PER ORDER POSTAGE AND PACKING



Use your credit card. Ring us on Ware 3182 NOW and get your order even faster. Goods normally sent 2nd Class Mail.
Remember you must add VAT at 15% to your order. Total Postage add £1.00 per Total order.

BBC Micro Forum...

David Whitfield MA MSc CEng MIEE

THIS month *BBC Forum* is looking at an improved version of the 8-line user port output driver described last month. The emphasis then moves on from user port outputs to inputs, with a numeric keypad add-on unit.

AN IMPROVED OUTPUT UNIT

As you may have noticed when using the 8-line driver unit described last month, there are many situations where the state of the output lines at start up (i.e. all 'on') can cause problems. There are a number of possible solutions to this problem. Perhaps the easiest solution (but unfortunately not always practical) is to make the load respond to the 'off' state rather than the 'on' state, i.e. use negative logic. The software then only needs to be modified so that an output line is set to 0 rather than 1 to cause action at the interface. Changing line 170 in last month's test program to:

```
170 ?(&FE60)=NOT(Count MOD256)
```

will effect this modification on the binary counting demonstration. As mentioned, however, the number of cases in which such a simple 'fix' can be used is rather limited. Ideally what we would like is for the outputs to be initialised to the 'off' state until the user VIA has been correctly set up.

To provide this type of control, however, another data line is required. This is unless we can spare one of the 8 data lines for the purpose, but this is best avoided since it is wasteful and, more significantly, it makes the programming rather tedious. If we look a little more closely at the 6522, however, there are still two lines on port B which we have not yet considered; CB1 and CB2. These are primarily intended to act as interrupt inputs or as handshake outputs. Each line controls an internal interrupt flag, with a corresponding interrupt enable bit. In addition, CB1 controls the latching of data on port B input lines. It is also possible to configure CB2 to behave as an additional data output.

Fig. 1 shows register 12 in the VIA, the Peripheral Control Register (PCR). From this we can see that the register is shared by the two sides of the VIA, so care is required to ensure that we only change the state of the side we want to change. Thus, when we write to bits 4-7 to change the B settings, we must first read the current A settings (on bits 0-3), and make sure that we re-write them correctly. Remember that every write operation to a VIA register affects all 8 bits, so even if we

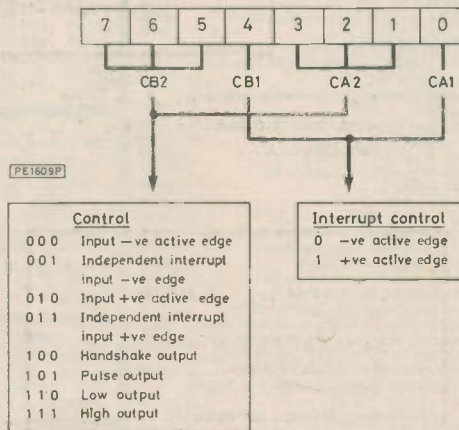

Fig. 1. Peripheral Control Register

only want to change 1 bit, we must re-write the settings of the unchanged 7 bits. Thus, by using the PCR, we can configure the CB2 line as an additional output control line. The only additional information we need is that when the VIA is reset, the CB2 line behaves as an input and any output circuitry will consider it to be at a logic 1.

Fig. 2 shows the 'improved' output driver circuit. The circuit is shown driving some 15V relay units, and is based on the circuit published last month. The inputs to the Darlington stages are held low until the CB2 line is driven low. The gating is provided by the CMOS NOR gates, whose inputs may be protected against possible static damage while disconnected by (optional) 1M input pull-down resistors. Listing 1 shows the revised binary counter demonstration with the new output unit; the l.e.d.s should now all remain extinguished until after the space bar is pressed. Note the method of setting up the PCR register so as to leave the settings of the A side unchanged, which first reads the settings for the A side, masks out the old B side settings, and then ORs the new B settings, before re-writing the PCR value.

The modified output unit should provide a useful improvement in situations where the interface hardware is powered up at the same time as the computer.

Fig. 2. Improved output driver circuit shown driving eight 15V relay units, and based on the circuit published last month. The circuit is intended for applications in which the interface is powered up simultaneously with the computer itself

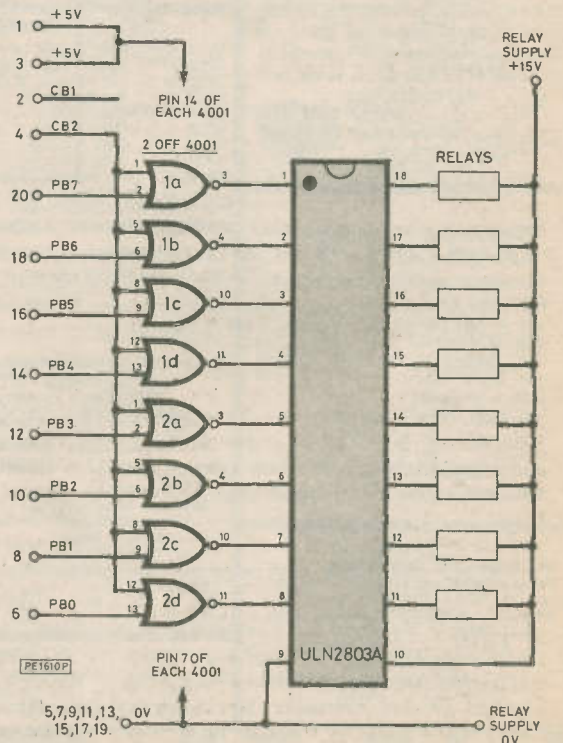

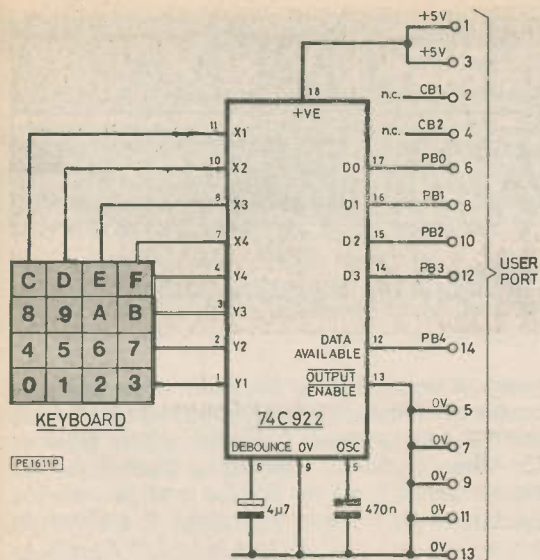

NUMERIC KEYPAD

Unlike some computers, the BBC Micro does not have a separate numeric keypad. Such a keypad can be extremely useful if any significant amount of numeric data input is required. Hexadecimal keypads are now readily available at reasonable cost, and are usually arranged as a matrix of 4 rows by 4 columns of switches. The identity of the pressed switch is found by detecting which row has been connected to which column. By scanning the rows and columns, a key depression may be detected and identified. The popular demand for this type of scanning has resulted in the production of specially designed i.c.s (e.g. 74C922) which perform all of the necessary functions.

SCANNING THE KEYS

The 74C922 provides all of the logic necessary to fully encode an array of 16 SPST switches into binary. The key scan is usually controlled by the internal clock, but it may be overdriven by an external clock. An internal key debounce circuit is included, and requires only a single capacitor to operate. The Data Available output goes high a debounce period after a key depression is made, and returns low when the key is released, even if another key has been depressed in the interim. A second key depression is recognised after the normal debounce period, and the Data Available line again goes high. This two-key rollover is provided between any two keys, and an internal latch stores the value of the last key pressed, even after the key has been released.

Fig. 3 shows the circuit for the add-on keypad unit. The prototype unit used an RS keypad (337-100), but suitable types are widely available. The 74C922 is available from a number of advertisers in PE, and it is recommended that it be mounted in an 18-pin d.i.l. socket. The connections between the RS keypad and the decoder i.c. are shown in Table 1. The prototype was built on a small

Matrix	Keyb'd Pin	I.C. Pin
Row 4	1	4
Col 1	2	11
Col 2	3	10
Row 1	4	1
Row 2	6	2
Col 3	7	8
Col 4	8	7
Row 3	9	3

Table 1. Specific connections between the RS type keypad and the 74C922 decoder i.c.

Fig. 3. The numerical keypad and its connections to the decoder i.c.

```

10 REM Set port all O/Ps
20 :
30 ?(&FE62)=&FF
40 ?(&FE60)=&00
50 :
60 REM Enable O/Ps and
70 REM wait for SPACE
80 :
90 PCR=?&FE6C AND &0F)
100 ?&FE6C = PCR OR &C0
110 REPEAT UNTIL GET=32
120 :
130 REM Binary counter
140 :
150 TIME = 0
160 REPEAT
170 Count=TIME DIV 100
180 ?&FE60=Count MOD256
190 UNTIL FALSE
200 END

```

Listing 1. I/O set-up routine

```

10 REM Keypad Test
20 REM *****
30 :
40 ON ERROR GOTO 230
50 MODE 7
60 VDU 23,1,0;0;0;0;
70 ?&FE62 = 0
80 PRINTTAB(8,8);
90 PRINT"D/A"SPC(7)"Key"
100 REPEAT
110 Port = ?&FE60
120 Key = Port AND &0F
130 DA=(Port AND&10)DIV 16
140 FOR I = 11 TO 12
150 PRINTTAB(18,I);
160 PRINT CHR$141;~Key;
170 NEXT I
180 PRINTTAB(0,11)DA;
190 UNTIL FALSE
200 :
210 REM Error/Escape
220 :
230 PRINTTAB(0,24);
240 VDU 23,1,1;0;0;0;
250 END

```

Listing 2. Keypad test routine

piece of veroboard, with the VIA data lines selected so as to allow a smaller cable to be used (only 14-way), while still carrying the d.c. supply. This means that that standard IDC plug is used at the computer end (pins 1 to 14), but at the keypad end a 14-pin d.i.l. i.c. plug/header can be used in conjunction with a 14-pin i.c. socket. This gives a convenient, but relatively low cost plug and socket arrangement. If such flexibility is not required, the conductors can of course be soldered directly to the board.

The simple polling program in Listing 2 allows the numeric keypad to be tested. Once run, the program will echo any keypad entry on the screen (until ESCAPE is pressed). This listing can obviously be amended so that the keys have different meanings to suit your particular application. In order to detect whether a new key has been pressed (rather than an old

one still being latched by the hardware), it is necessary to monitor the Data Available line on data bit 4 of the interface. A more sophisticated driver for this keypad would be interrupt-driven, written in machine code, and use the Data Available output connected to one of the CB lines. This could then also insert key depressions (or whatever the keys have been re-programmed to represent) directly into the keyboard buffer using a ★FX138 call. The keypad would then behave as if the character(s) programmed for the keys had been typed in normally. Readers' suggestions for such a driver are always welcomed by BBC Forum Letters, at PE's editorial address. As with any such project, the real value of the keypad is the use to which you can put it! NEXT MONTH: BBC Forum will be looking at a real time clock for the user port.

BBC

MICRO...PRINTER

SOFTWARE REVIEW

MICHAEL TOOLEY BA DAVID WHITFIELD MA MSc CEng MIEE

PRINTER software can significantly increase the flexibility and ease of use of your computer's printer. To be precise, the software referred to here is printer driver software, which runs on the micro and either adds missing facilities or makes existing printer features easier to use. Following on from our printer survey, we are looking at two software packages from **Watford Electronics** for the BBC Micro. Both are provided in read-only memory (ROMs) to fit in the paged-ROM sockets inside the computer, and means that the new facilities they offer immediately are constantly available once installed. The first ROM provides a near letter quality (NLQ) fount for the popular Epson range of printers, and thus adds a facility not normally available. The second provides a versatile graphics and text dump package which is compatible with the majority of popular dot matrix printers, making best use of the existing graphics facilities on these printers.

EPSON NLQ PRINT ROM

Near Letter Quality

One of the greatest drawbacks of dot matrix printers is their inability to produce so-called letter quality print. The standard for comparison here is usually taken to be that which can be obtained from a good quality office electric typewriter. As mentioned in the printer survey, daisywheel printers produce print of letter quality, but dot matrix types cannot produce output of such a high quality. Normal dot matrix printing typically uses a matrix of 7 by 9 dots, giving a high printing speed, but with a quality which does not even approach letter quality. A photocopy of the output, on the other hand, is frequently better than the original.

Improved dot matrix founts are obtained by using a greater number of dots to form each character. As dot matrix printers have become more popular, an ever-wider range of founts has been provided on successive models. These have provided higher print quality (usually at the expense of lower printing speed), using the same 9-wire printhead, but using a greater number of dots to form each character. The user can then select the most appropriate fount for this application; usually the standard fount for draft work, and one of the higher quality founts for finished work.

What do you get?

The NLQ ROM from Watford allows a near letter quality fount, not normally available, to be produced on the Epson FX or RX range of printers. The NLQ fount caters for the full UK character set, and may be used directly from the keyboard or from Basic, Wordwise, View or most other programs and languages. The fount can even be used in conjunction with enlarged, underlined and proportional typefaces (even though the RX80 does not normally have a proportional spacing facility).

The software is supplied in an 8K ROM, costs £20 plus VAT, and comes complete with ROM fitting instructions and a spiral bound 8-page manual. A special printer driver is available for View for £7.50. The fitting instructions are clear and detailed; once fitted, the ROM is ready for use. The obvious question then is how well does it perform in practice?

The ROM in action

The simple answer to the question posed above is that the NLQ ROM is breathtakingly effective. A comparison between the standard Epson founts and the corresponding NLQ founts is shown below. In real life the differences between the two sets of founts are even more marked than can be shown, due to the limitations of the printing process used in the production of the magazine. So much for the short answer, but how easy is the NLQ ROM to use?

This is the default Epson fount

Any line may be underlined

Line of proportional spacing

An enlarged line

This is the basic NLQ fount

This is underlined

This is proportionally spaced

An enlarged line

All-features line

Epson and NLQ founts

After installation, the ROM announces itself in response to any *HELP command. Typing *HELP NLQ causes the ROM to display a full screen of help text, including the syntax of all of the NLQ commands. This explanation is actually easier to refer to than the manual, which although it contains all of this information and much more, lacks such a quick-reference summary. In fact, one of the only criticisms attached to the whole package is that the manual, while comprehensive and clear, is organised in a slightly confusing order for the first-time reader. A copy of the help screen text would have been a very useful addition to the manual. However, once the manual has been read, the help display is the only reference required to make full use of the NLQ facilities.

At this point it is worth noting that the NLQ ROM is rather particular about the syntax of its commands. Unlike much other ROM-based software, this ROM will *not* accept commands typed in lower case, e.g. *nlq, or abbreviated in any way. This is not a major criticism, but it would have been nice to have seen lower case and abbreviated command syntax supported, e.g. *NLQ could have been assumed equivalent to the more popular *NLQ80. There are only a small number of short commands to get used to, however, so this is more of an initial irritation than a long-term drawback.

The ROM is initialised by typing *NLQ80 or *NLQ100, depending on whether you have an FX/RX-80 or an FX-100. This sets up the length of the print line to 80 or 120 characters, respectively, re-directs one of the operating system's service vectors to point to the NLQ ROM, and allocates it a workspace buffer. The default buffer is the cassette/RS423 input buffer, but this can be changed very easily, as explained in the manual. This re-direction of the service vector is necessary because the NLQ fount works by intercepting all characters sent to the printer. At this stage, however, the NLQ fount is not yet active, and it passes on all output direct to the printer so that all printing continues to operate as normal.

The NLQ fount is activated from the keyboard by typing *NLQTYPE, from Basic by a VDU129 command, or by sending a 129 control code from a wordprocessor, e.g. OC129 in Wordwise. Why this command is not *NLQON is a source of some mystery, since then it would then be the logical counterpart to *NLQOFF, described below. All output following the *NLQTYPE command (or equivalent) is produced in NLQ fount. The ROM uses the printer's graphics facilities and character dot patterns contained in the ROM, rather than any of the internal founts, to print the NLQ characters. In addition to the standard NLQ fount, proportional spacing, underlining, temporary enlarged and enlarged printing can be selected or reset in any combination.

When printing, the NLQ fount is approximately 5 times slower than the standard fount, and is thus comparable with other printers which already have an NLQ fount provided as standard, e.g. Kaga. The density of the NLQ print is significantly darker than that obtained in the default fount, due to the much higher number of dots used to produce each character, and this also contributes to the improvement in print quality.

Printer control codes such as form feed or margin set must not be sent to the printer while the NLQ fount is active. The fount must first be turned off (VDU193 or output a 193 control code) and then the codes sent; the fount is re-enabled via *NLQTYPE, VDU129 or output of a 129 control code. These procedures are all well explained, complete with examples, in the manual. If the procedures are ignored, and non-NLQ control codes are sent while the fount is active, then the printer may hang. When no more NLQ printing is required, the ROM may be turned off and the operating system vectors reset by typing *NLQOFF.

VERDICT

The NLQ ROM is to be highly recommended for any Epson FX/RX printer owner, and represents an excellent investment for anyone who wishes to use it for high quality printing. The ROM works extremely well, with only a few very minor irritations. The NLQ ROM is assured of a long stay in the reviewers' BBC Micro.

PRINTER DUMP ROM

Printer Dumps

The great majority of home computers are now capable of producing high resolution graphics and colour displays. Typically, such displays use around 540 lines, with up to 640 pixels per line. These figures now compare very favourably with the resolution available from a typical dot matrix printer, which is usually capable of printing between 500 and 1000 dots per print line.

With the introduction of dot matrix printers, which include dot-addressable graphics facilities, the way has been opened to the possibility of printing pixel images of the screen contents. What is required, however, before such a print can actually be produced is a software package capable of interrogating the screen image (in the computer's memory) to determine the state of each pixel (on/off/colour), and sending the appropriate sequence of print commands to the printer. In this way, the computer's image is converted into a dot-image on the printer. This is usually done 8 or 9 dots at a time, depending on the number of wires in the printhead. The resulting print is usually referred to as a graphics dump, while the software that produces it is a printer dump software utility.

Printer dump software packages vary considerably in their ability to handle different printers, different screen modes and multiple colours. In addition, the more advanced packages will allow variable scaling of the dump, margin setting, and even rotation of the printed image. It is therefore important to be clear on the facilities you require from a printer dump before embarking on a purchase.

What do you get?

The Dumpout 3 ROM from Watford represents one of the most sophisticated types of printer dump utilities available for the BBC Micro. It caters for a wide range of dot matrix printers, identified in Table 1. In addition to graphic screen dumps for all graphics modes (including the 'mode 8' introduced in the Advanced User Guide), Dumpout 3 also provides fast, text-only screen dumps for all printers. Other features included in the ROM are interactive text and graphics window setting utilities, and two new OSWORD calls which allow testing and plotting of mode 7 pixels using the standard graphics coordinate system.

The Dumpout 3 software is provided in an 8k ROM which costs £22, plus VAT, and comes complete with a comprehensive 25-page spiral bound manual, and ROM fitting instructions. Fitting the ROM is as straightforward as for the NLQ ROM.

Watford Electronics DUMPOUT 3.0p

PRINTERS

SEK	Seikosha GP80/100
SEK2	Seikosha GP250
TND	Tandy LPVII/DMP100
DMP	Tandy DMP120/200
NEC	PC8023
EPSON	FX/RX/MX
SHINWA	CTI CP80

Table 1. Printers supported by Dumpout 3

The ROM in action

Once installed, Dumpout 3 will announce itself in response to a *HELP command. Typing *HELP DUMPOUT instead will produce a listing of the syntax for the four dump and window * commands, whereas *HELP PRINTERS identifies the printers supported by the ROM, together with their codes (see Table 1). The software recognises any of its commands in either upper or lower case, and they may also be abbreviated by a "...", so long as the abbreviated command is still unique. The syntax of all commands is explained in detail in the manual, but unfortunately without the summary; the printer summary, on the other hand, *is* repeated in the manual.

The new * commands provided by Dumpout 3 are as follows:

***GIMAGE** This provides a full graphics dump in any mode. There are various optional parameters to control various aspects of the dump, but you only need to specify those which you wish to change from their default values. These optional parameters may be given in any order, since each is prefixed by its identifying letter. The simplest command only needs to include the printer parameter, e.g. *GIMAGE EPSON, to produce a dump on the printer with the default parameter settings. In most cases, users will only wish to alter a few of the parameters for a particular dump. The parameters available are shown in Table 2, along with brief descriptions of their effect.

***TIMAGE** This produces a fast text-only dump of the text window in any mode. Graphics characters appears as a "*", and the command may be used with the X, Y and I parameters in Table 2, although the parameters now refer to text coordinates.

***GWINDOW** This command draws flashing markers on the screen to indicate the current graphics window. The window may then be altered using the cursor keys. Other keys allow the window to be reset to the default setting, or determination of the VDU values which will produce the currently displayed window.

***TWINDOW** This command is the text version of *GWINDOW. As before, the VDU values necessary to set up the window may be determined by pressing the P key.

- <printer> Selects the printer type. The codes used are those in Table 1.
- C Prints all mode 7 graphics contiguously to improve the shading of separated graphics.
- E Expands the contrast to make mode 7 text and separated graphics stand out from the background.
- F Fast dump using fewer dots, therefore producing a dump of lower resolution.
- G Grey scale (white prints as white), rather than the normal white prints as black.
- H <scale>, V <scale> These two parameters give control over the size of the dump.
- I <amount> This causes the print to have a left-hand margin of the specified size.
- L Linear step size for reduced distortion, but different dump size and aspect ratio, depending on the printer.
- M An 8-colour mask determine which colours are printed and which ignored (printed as white).
- P Use physical colours rather than logical colours for the dump.
- R <0-3> This allows the print to be rotated by 0, 90, 180 or 270 degrees.
- T Two-tone dump for maximum resolution.
- X <min>,<max>, Y <min>,<max> These parameters specify a subset of the graphics screen for dumping.

Table 2. Parameters for *GIMAGE

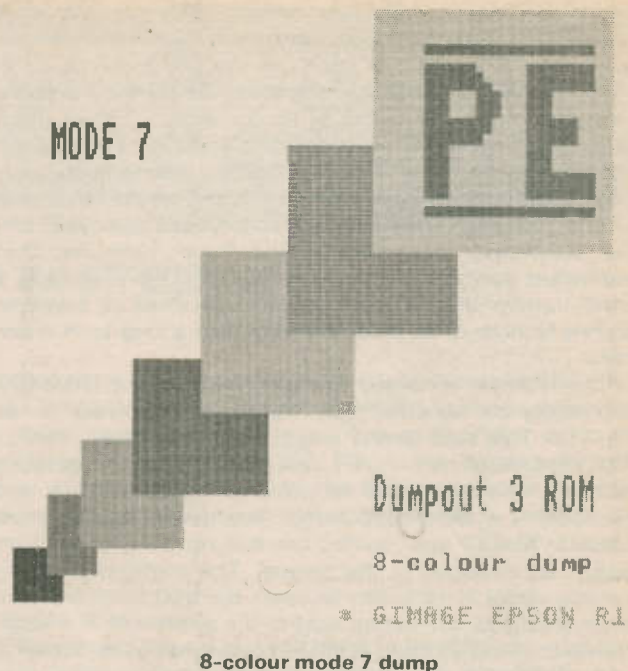

The two new OSWORD calls provided by Dumpout 3 are:

OSWORD &89 Read a mode 7 pixel.

OSWORD &8A Plot a mode 7 chunky graphics pixel.

The manual includes a full description of these new calls, complete with a Basic program to demonstrate the use of the new plot call.

So much for how the ROM's facilities are called up, but how do they work once invoked? At this point it is only fair to point out that Dumpout 3 is an extremely sophisticated and powerful dump utility, and hence the full syntax of the graphics dump command is rather complex. The simplest form, however, is very straightforward, and users can start from there and gradually extend their use of the optional parameters.

The first thing which newcomers to graphics dump software will notice is the time taken to produce a graphics dump. A mode 7 screen typically takes 9 seconds for a text-only dump on an Epson FX80, but 5 minutes and 20 seconds for a graphics dump of the same screen! The fast option (F) brings the graphics dump time down to 3 minutes and 40 seconds. Using this option, the quality of output can be traded off against the time taken to produce the dump. A useful compromise is obtained by selecting the fast, two-

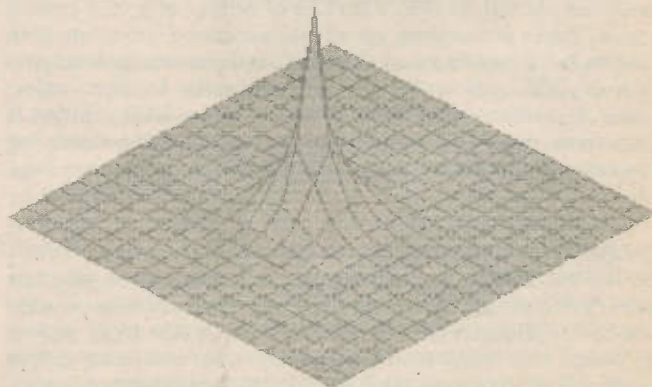

Mode 1 graphics dump

tone graphics option. Something noticeable about the graphics dumps is that, in common with most other dump software, the printer still attempts to dump blank lines. This means that the dump print time is independent of screen contents.

Using the simplest form of the graphics dump command with an Epson printer (*GIMAGE EPSON) causes the dump to miss out the right-hand side of the screen. This can be cured by altering the horizontal and vertical scales away from their default settings, or much easier, by rotating the whole dump through 90° (*GIMAGE EPSON R1). This will cause a complete dump to be produced, with a pleasantly natural looking aspect ratio. Dumps of almost any size and shape can be produced by altering the various parameters, and circles can even be printed to appear circular (not normally as easy to do as you might think!). The result of a full 8-colour mode 7 dump is shown above, whilst a mode 1 graphics dump is shown below; the quality of the results speak for themselves.

All of the dump options appear to operate correctly without any corruption of the memory contents, and can, for

example, be called from Wordwise. While dumping, there is a significant delay after each line is printed (presumably while the next line is processed) and this seems to make the dump take even longer than it actually does. Also, in common with most other dump software, the same time is taken to dump blank lines is the same as for lines of symbols.

The text and graphics window commands work very much as expected, and are easy to use; they can even be used from within programs. The only problem appears to be that there is only limited bound checking on the graphics window, meaning that the window limits can be set beyond the limits of the screen. This is unlikely to cause any problems, but is a little confusing at first.

VERDICT

The Dumpout 3 ROM has all of the facilities which you are ever likely to need for producing printer dumps. The facilities work extremely well, and if printer dumps are something which you require, this ROM can be recommended to help you to get the best out of your dot matrix printer.

FREE! READERS' ADVERTISEMENT SERVICE

PE BAZAAR

WANTED concave mirror. Anything considered. Also small ultrasonic bath. Good price for both. Tel: 0909 564289.

34 WAY I.D.C. female sockets secondhand no location peg otherwise perfect. 80 pence each Posted. Mr. G. T. Medermid, 4 Aspian Drive, Coxheath, Maidstone, Kent ME17 4JZ.

WANTED Sony black and white video camera type: HVM-100CE in good working condition. Tel: Mark, 0705 833400.

TOSHIBA 30W Hi-Fi speakers £20 pair. Please ring 0206 48603 for details.

COMPONENTS transistors, relays, capacitors, resistors, plugs, sockets, pots, motors, lamps, wire, valves, nuts and bolts etc. 16lb £20 inc. post. M. R. W. Eames, 22 Beach Road West, Portishead, Bristol BS20 9KY. Telephone (evenings) 0272 848273.

PE 1965 to 1978 some missing. PW 1964 to 1978 many missing. Offers whole or part. Mr. D. A. Scott. Tel: Farnborough (Kent) 55965.

GRIP top plastic bags. Excellent for component storage etc. Sizes tiny to huge. SAE for details. Martin Harlow, Maycot, 194 Old Woking Road, Woking, Surrey GU2 8HR.

WANTED Hacker or Roberts AM portable. Write to: J. Anderson, 22 Landau House, Chatsworth Road, London NW2 4BW.

FOR sale multimeter digital Philips PM 2521 cost £365, accept £250. Manual. Tel: 0704 31153.

CB RADIO, 40 channel legal, brand new, unwanted present £20. Mr. Geoff Marshall, G3XGM, 16 Inverness Road, Southall, Middx. UB2 5QG. Tel: 01-571 2252.

WANTED 'COMX 35' computer or any software, for 'ELF 2' computer on 'RCA 1802' microprocessor based system. Jon Madden, Flat 2, 1a Asfordby Street, Leicester LE5 3QJ.

6809E and 74LS783 £4 each. 10+ £35. 22µF 16V capacitors, electrolytic £2 per 100. All new. N. E. Spiers, 114 Green Way, Tonbridge Wells, Kent TN2 3JN. Tel: 0892 44070.

WANTED stereo head F.P. 14 for Ferrograph tape recorder. Phone Burton-on-Trent (0283) 32616 after 6 p.m.

CIRCUIT related to Woburn electronic organ loan or buy, older type. T. A. Potter, 2 Lindsay Cottage, Sandycroft, Deeside, Clwyd. Tel: 531679.

WANTED purchase or loan service sheets and handbook Waltham music centre STM35 or photostats please. W. R. Critchley, 11 Hale Road, Helpringham, Sleaford, Lincs NG34 0RL. Tel: Swaton (052 921) 237.

WANTED 6 MAN74A 7 Segm. displays. J. P. Amigo, 5 Canterbury Crescent, London SW9.

MANUAL for Tektronic 453A oscilloscope wanted. Tel: Mr. Cory during working hours Bodmin (0208) 3161 (Cornwall).

WANTED Acorn Atom disc system or special parts of same, i.e. DOS, ROM etc. Mr. A. R. Knight, 32 Meadow Close, Farmoor, Oxford OX2 9NZ.

UK101 Cegmonx 64 x 32 display. Microcase. Word processor, games, assembler. £100. Basic 4 £6. Basic X £10. Sound/via £29. D. Pitts, 1 Bell Leys, Wingrave, Nr. Aylesbury HP22 4QD. Tel: 029 676 547.

WANTED TRS80 level two computer. Tel: 01-965 0871. Patrick Butete, 39 Gloucester Close, London NW10 8EG.

WANTED N.A.C. triple T receiver 01-451 3093. Mr. J. Anderson, 22 Landau House, Chatsworth Road, London NW2 4BW.

Please publish the following small ad. FREE in the next available issue. I am not a dealer in electronics or associated equipment. I have read the rules. I enclose a **cut-out valid** date corner.

Signature Date

Please read the RULES then write your advertisement here— one word to each box. Add your name, address and/or phone no. **COUPON VALID FOR POSTING BEFORE 3 MAY, 1985** (One month later for overseas readers.)

SEND TO: PE BAZAAR, PRACTICAL ELECTRONICS, WESTOVER HOUSE, WEST QUAY ROAD, POOLE, DORSET BH15 1JG.

BLOCK CAPITALS PLEASE

Name & Address:			

For readers who don't want to damage the issue send a photostat or a copy of the coupon (filled in of course) with a **cut-out valid** "date corner"



INDUSTRY NOTEBOOK

By Nexus



Then and Now

Some 12 years ago (June 1973 issue) I optimistically suggested that with increasing competition the price of pocket calculators could fall to as little as £20. Clive Sinclair had been first in the field with a model selling for around £70. There were 40 different models available, all heavily discounted from their recommended retail price.

Then PE had a cover price of 20p, now increased to 100p, exactly in line with inflation. So my forecast price of £20 then translates to £100 today. How wrong I was! The cheapest model I found in the shops this year was a Woolworths' special offer at £2.99, the second cheapest in W. H. Smiths at £3.99. Both these had better facilities, better design, more reliability than equivalent models of 12 years ago. Converting back to 1973 prices they would cost 60p and 80p respectively, rather less than £20.

The price war which benefited the customer so much drove all but the most efficient manufacturers out of business. The same pattern has now emerged with the budget-priced home computer. First the breakthrough of a new concept, soon copied. Phase two, with prices tumbling and weaker new entrants withdrawing either voluntarily or through bankruptcy. Phase three, emergence of competition from the Far East. Phase four, virtually all production concentrated in the Far East.

Well, it may not happen just like that this time round. But already a number of UK companies have gone to the wall, others are in trouble and even the strongest are vulnerable.

Of course the consumer market has always been volatile in fashion and in seasonal appeal. The expected sales boom last Christmas looked more like a slump. This, coupled with an ill-fated venture into the United States, appeared to have hit Acorn badly with a consequent knock-on effect on subcontractors like AB Electronic and component suppliers.

Bad news for the British manufacturers, maybe, but good for the consumer. There will be no shortage of product or of choice. And prices will become even more competitive. The only difference, undetected by the casual purchaser, will be the country of origin.

It can be argued, and often is, that British industry should be protected by tariffs or even an outright ban on imports. Had that policy been implemented back in 1973 we might still be buying Sinclair pocket calculators. They would cost less than £100 with improved manufacturing methods and less costly components, but no manufacturer here could possibly match £2.99! From a costly but desirable and useful aid, the pocket calculator in a little over a decade has become an everyday, throwaway item.

We couldn't beat the foreign competition in pocket calculators or CB radios and I would expect the bottom end of the home computer market to follow the trend. Unfortunate, even sad, but true.

Start-ups

All's fair in politics, but misrepresentation can be taken too far. The opposition parties can hardly conceal their delight when statistics of seeming disaster are made public. Yes, bankruptcy and liquidations were at record levels in 1984. To be precise, 14,210 company liquidations and 8,509 bankruptcies of individuals and partnerships. It sounds awful, and no doubt was to the people concerned. The parallel statistic, carefully played down by the opposition, is that in the same period new company starts were of the order of 100,000, also a new record.

Among the many schemes to assist new start-ups is Scottish American Venture Enterprise, a new unit trust with the backing of the Scottish Development Agency. The idea is to link Silicon Glen more closely with Silicon Valley by making available some 25 million dollars of venture capital to assist Californian high-flying high-tech companies to form partnerships with Scottish companies or, possibly, to set up subsidiaries in Silicon Glen.

Heading Scottish American Venture Enterprise is a highly respected and successful American businessman of Scottish ancestry. His name is Mr. Ian MacGregor, best known in the UK as chairman of the National Coal Board.

Who owns whom and the multi-national nature of electronics is always fascinating. I hadn't realised, for example, that the Church of England is a big shareholder in our own GEC. Or, more remarkable, that the American property arm of the church includes two premises rented profitably to high-tech companies in Silicon Valley. The Church Commissioners, who mastermind the finances of the church, clearly know a good thing when it comes along. Like doubling their money on 3.5 million shares in British Telecom.

Getting back to start-ups, I note that Du Pont (UK) is setting up manufacture of Berg

connectors at Yate, near Bristol, with an investment of nearly £5 million. Some years ago I visited their factory in Holland. It was the first and, so far, only factory I have seen which had wall-to-wall carpeting and pot-plants in the machine shop. They needed drip-trays under the machines but even they looked strangely and clinically clean. I hope the Yate plant will be equally luxurious and, of course, efficient, which was what that delightful decor was all about.

At Government level we have news of a British National Space Centre, possibly to be located at Farnborough. This will be a focal point for all the space activities now scattered around government departments, industry and the universities. It will tie in with the existing European Space Agency and also participate in US plans for a space station. UK contribution is expected to be £200 million, with plenty of new jobs.

Capital Goods

While the consumer sector of the industry suffers unduly from stop-go, the capital goods sector is all go-go with plenty of new records. Here are two examples, both US-owned but with a large measure of autonomy in their UK operations.

Hewlett-Packard Ltd 1984 results showed turnover up 44 per cent to £293 million, pre-tax profits up 41 per cent to £17.6 million. Eighty per cent of all UK production is exported. Capital investment up 46 per cent and 653 extra employees bringing the total to 3,089.

IBM UK in relative terms out-performed its US parent. The UK results showed a 40 per cent jump in turnover to £2.35 billion and profit after tax reached £200 million, an increase of 36 per cent compared with 14 and 19 per cent gains for IBM USA.

Incidentally, David Baldwin, H-Ps managing director, was one of the British industrialists who submitted evidence to the House of Lords Select Committee on Overseas Trade. Not unnaturally, he favours multi-national investment in the UK arguing, correctly, that multi-nationals bring new technology and managerial skills as well as employment. He deplores the chronic skill shortage in the UK, as we all do. While recognising the many measures the government has undertaken to promote IT there has been fragmentation and he advocates a long-term strategic partnership between industry and government co-ordinated by a Ministry of Information Technology.

Steady business continues in broadcast equipment. ITN has moved into satellite news gathering with GEC McMichael portable earth terminals. Coupled with existing ENG techniques and a computerised news room, ITN says no news item, wherever it happens, is more than two hours away. Among Crow of Reading recent orders is a £100,000 outside broadcast van for Hong Kong Television. And Marconi's new range of television transmitters have an excellent chance of sales in the Americas through a tie-up in marketing with Comark Communications Inc. of the United States.

The first digital self-build organ-synth incorporating RS232 & MIDI interfaces



See and hear the new generation of Wersi!

Alpha kits from £1356

Also in digital range:
BETA S, T, CP. 4 octaves
DELTA & GAMMA
5 octaves, full pedal board.

ALPHA

The world's first Computer Organ which is totally digital, portable and self assembled

(Also in console mode)

The Alpha has a star-studded pedigree! Wersi names like the Helios and Galaxy - played by Franz Lambert and Klaus Wunderlich. From this world pedigree a new star is born - Alpha!

- Available in kit form (app. 40 hours to build) or ready-built.
- Weighs only 58 lbs (portable model).
- Using built-in RS232 and Midi-interfaces, Alpha can be played and programmed via home computer.
- Built-in computer can programme your own sounds, storable on data cassette.
- Surprisingly low price!

Post the coupon today for Alpha literature and address of nearest stockist.

Enclose £1 (returnable) for Alpha demonstration record.

Please send me a brochure on the fabulous Wersi Alpha.

I enclose £1 for demonstration record.

Name _____

Address _____

Post Code _____

Wersi Organs & Pianos Ltd., Dept C, 14/15 Royal Oak Centre, Brighton Road, Purley, Surrey. Tel: 01-668 9733.

Aura Sounds, 1729 Coventry Road, South Yardley, Birmingham. Tel: 021-707 8244

Aura Sounds, 17 Upper Charter Arcade, Barnsley, Yorks. Tel: 0226-20 5248



MARCO TRADING



DIODES

IN916	0.04	AA119	0.12
IN4001	0.05	AA129	0.18
IN4004	0.06	AA130	0.16
IN4005	0.06	BA100	0.24
IN4007	0.07	BY126	0.12
IN4148	0.05	BY127	0.10
IN4149	0.06	BY133	0.16
IN5400	0.12	BY184	0.40
IN5401	0.15	OA47	0.10
IN5402	0.15	OA90	0.08
IN5404	0.16	OA91	0.09
IN5406	0.18	OA95	0.18
IN5408	0.20	OA200	0.06
IS44	0.06	OA202	0.15
IS921	0.08	IN914	0.04

MINI D CONNECTORS

9 way	15 way	25 way	37 way
Solder Lug	52p	65p	88p
Right Angle	89p	£1.34	£1.98

SOCKETS

Solder Lug	78p	98p	£1.33	£2.48
Right Angle	£1.18	£1.78	£2.70	£4.15

COVERS

95p	95p	98p	£1.00
-----	-----	-----	-------

MULTI METER SPECIAL

Requires AA cells (not supplied) and leads, etc.
Russian Type A (4324) 20000 O.P.V.
D.C. Voltage: 0.6, 1.2, 3, 12, 30, 60, 120, 600, 1200
A.C. Voltage: 3.6, 15, 30, 150, 300, 600, 900;
D.C. Intensity M/A: 0.05, 0.6, 6, 60, 600, 3000;
A.C. Intensity M/A: 0.3, 3, 30, 300, 3000;
D.C. Resistance: 0.2, 5, 50, 500, 5000 Ω /hm;
g.e. level dB: -10 to +12

£12 FANTASTIC SPECIAL PRICE:
including P/P and VAT

74LS

LS00	28p
LS01	28p
LS02	28p
LS03	28p
LS03	32p
LS08	28p
LS09	28p
LS10	28p
LS11	28p
LS12	25p
LS13	33p
LS14	58p
LS15	25p
LS20	28p
LS21	28p
LS22	28p
LS30	30p
LS32	28p
LS37	23p
LS74	38p
LS122	70p
LS138	45p
LS139	68p
LS151	75p
LS155	50p
LS157	45p
LS158	58p
LS160	60p
LS161	70p
LS162	72p
LS163	80p
LS166	1.95
LS170	1.75
LS244	1.00
LS245	2.00
LS257	73p
LS393	1.15

SOLDERING AIDS

Antex 15W iron	5.00
Antex 18W iron	5.00
Antex 25W iron	5.20
Antex Elements	2.00
Antex Bits	0.95
Antex stands	1.90
Desolder Tool	4.50
Spare nozzle	0.45
25W Kit-iron with 13A plug & stand	ONLY 6.20

NI-CAD CHARGER

Universal charger to charge PP3, AA, C, D PRICE 6.00

NI-CADS

PP3	4.45, 4/16.00
AA	0.95, 10/8.00
HPII	2.30, 4/8.50
C	2.35, 4/8.75

VOLTAGE REGULATORS

78L05/12/15	0.30
7505/12/15	0.55
7905/12/15	0.65
LM317K	3.50

RESISTOR KITS

1/4W Pack 10 each value E12 10R-1M	ONLY 4.80
Total: 610 resistors	
1/4W Pack 5 each value E12 10R-1M	ONLY 2.75
Total: 305 resistors	
1/2W Pack 10 each value E12 2R2-2M2	ONLY 5.25
Total: 730 resistors	
1/2W Pack 5 each value E12 2R2-2M2	ONLY 3.50
Total: 365 resistors	

TELECOM EQUIP

BT Plug & 3M lead	1.25
BT MASTER SOCKET	2.85
BT Sec Skt	1.95
BT 4-core cable	1M 0.15 100M 12.00

ROTARY POTS

0.25W Carbon Log & Lin 1K-2M2	each 0.32
	10 3.00
	Any 100 28.00

VEROBOARD

2 1/2 x 3/4	0.85
2 1/2 x 5	1.00
2 1/2 x 17	3.07
3/4 x 17	1.05
3/4 x 5	1.15
3/4 x 17	4.10
4 3/4 x 17 3/4	4.95
Pkt of 100 pins	0.30
Spt face cutter	1.48
Pin insert tool	1.85
Vero Wiring Pen & Spool	3.50
Dip Board	3.85
Vero Strip	1.25

PLUGS & SOCKETS

Metal Co-ax Plug	0.18	10/1.50
Plastic Co-ax Plug	0.14	10/1.20
Single Junction Socket	0.80	10/6.00
Plastic Phono	0.15	10/1.00
FM Plugs	0.20	10/1.75
1PL259	0.38	10/3.50
Resistors	0.15	10/1.25
1/4in Plastic Mono Plug	0.15	10/1.20
1/4in Metal Mono Plug	0.30	10/2.30
2.5mm Plug Metal	0.15	10/1.40
3.5mm Plug Metal	0.16	10/1.00
2.5mm Chassis Socket	0.10	10/0.80
3.5mm Chassis Socket	0.15	10/1.20
2 pin 1/4in Mono Chassis Socket	0.14	10/1.75
4 pin 1/4in Mono Chassis Socket	0.20	10/2.70
6 pin 1/4in Mono Chassis Socket	0.30	10/4.25
4mm Banana Plug	0.15	10/1.20
4mm Banana Socket	0.15	10/1.00

SERVICE AIDS

ALL SERVISOL PRODUCTS

Switch Cleaner	0.98
Foam Freezer	1.14
Aero Klene Silicone	0.96
Grease (Aerosol)	1.22
Antistatic Spray	0.98
Plastic Seal	1.08
Excel Polish	0.92
Fire Extinguisher, 640g	2.80
Video Head Cleaner	0.88
Soldra Mop (Std)	0.74
Soldra Mop (1/4 Gauge)	0.74
Additional P&P on above	30p

L.E.D.s

3mm Red	10p	10/85p
Green	13p	10/1.00
Yellow	13p	10/1.00
5mm Red	10p	10/85p
Green	13p	10/1.00
Yellow	13p	10/1.00

TRANSISTORS

AC128	0.30	BF338	0.38
AC176	0.28	BFX26	0.28
AF239	0.68	BFX84	0.24
BC107	0.10	BFX85	0.26
BC108	0.10	BFX87	0.26
BC109	0.10	BFY50	0.21
A.B.C.	0.12	BFY52	0.21
BC147	0.09	BFY90	0.90
BC182	0.09	BSX20	0.34
BC182L	0.09	BU208	1.55
BC184	0.09	BU407	1.65
BC184L	0.09	MJ2955	0.90
BC212	0.09	OC45	0.58
BC212L	0.09	OC71	0.50
BCY70	0.15	OC72	0.52
BDI31/2	0.34	TP31A	0.44
BDI33	0.56	TP32A	0.42
BDI35	0.32	TP33C	0.88
BDI36	0.36	TP34A	0.72
BF115	0.32	TP2955	0.60
BF184	0.32	TP3055	0.60
BF185	0.32	TP543	0.88
BF194	0.08	TIS88	0.40
BF195	0.10	2N3055	0.45
BF196	0.10	2SC1096	0.68
BF197	0.10	2SC1173Y	0.82
BF200	0.20	2SC1306	0.92
BF224	0.20	2SC1307	0.40
BF244	0.26	2SC1957	0.76
BF244A	0.28	2SC2028	0.73
BF244B	0.30	2SC2029	2.10
BF259	0.32	2SC2078	1.05
BF262	0.30	2SC2166	1.20
BF263	0.30	3SK88	0.65
BF337	0.38	40673	0.80

TRANSFORMERS

British made transformers at very attractive prices.					
Primary	Secondary	Current	1+	10+	100+
240v:	6-0-6v	100mA	0.58	0.52	0.43
240v:	6-0-6v	500mA	0.65	0.60	0.48
Carriage 45p per transformer. £1.60 per 10.					

MARCO TRADING (DEPT PE5)
The Maltings
High Street
Wem, Shropshire SY4 5EN
Tel: 0939 32763 Telex: 35565

ORDERING: All components are brand new and to full specification. Please add 50p postage/packing (unless otherwise specified to all orders then add 15% VAT to the total. Either send cheque/cash/postal order or send/telephone your Access or Visa number. Official orders from schools, universities, colleges, etc. most welcome. (Do not forget to send for our 1985 catalogue - only 65p per copy. All orders despatched by return of mail.
NEW RETAIL 1,000 sq. ft. shop now open! Mon-Fri 9.00-5.00, Sat 9.00-12.00

MARCO 85
Electronics Components Catalogue
1985 CATALOGUE
Our latest 123 page catalogue over 4000 items fully illustrated. Send 65p now for your copy. FREE with orders over £5.00.



Mail order & shops:

441 PRINCES ROAD, DARTFORD, KENT DA1 1RB
Telephone: (0322) 91454

ORDERING INFORMATION: P/P 50p on orders less than £20 in value otherwise post free. All components full spec & guaranteed. Discounts available on orders over £50 — phone for details. For unlisted components phone for price. Goods normally despatched by return post.

NEW CATALOGUE NOW AVAILABLE CONTAINING THOUSANDS OF LINES MANY ILLUSTRATED

This incredible volume contains everything required by the home constructor, amateur radio and CB user and computer enthusiast.

We think the semiconductor section contains more types than have ever been offered to the hobbyist.

Sections are headed as follows:

**Aerials, Amplifiers, Audio Accessories,
Batteries, Boxes, Bulbs, Capacitors,
Crystals, Car Components, Car Audio,
CB & Ham Equipment, Computer
Connectors, Fuseware, Hardware,
Headphones, Knobs, Lamps, Leads,
Loudspeakers, Microphones, Meters,
OPTO, PCB, Resistors,
Semiconductors, Special Effect
Equipment, Switches, Power Supplies,
Test Equipment, Tools, Transformers,
Wound Components.**

In addition to listed items we continue to provide a procurement service for obsolete and difficult to obtain types.

How many suppliers do you have at the moment that offer a service like this?

Please fill in coupon below and send with £1.25. Print clearly as coupon is used as address label.

Catalogue contains £2.50 discount order form — You make a profit straight away.

NAME

ADDRESS

.....

POSTCODE

CROFTON ELECTRONICS

THE CCTV & VIDEO SPECIALISTS



As specialists in video engineering our comprehensive catalogue is a must for companies or individuals interested in security or other aspects of CCTV or video.

The 4 split image multi-scan shown above is just one item from our range of T.V. cameras, fixed and zoom lenses, sequential switchers, specialists and general monitors (colour and b/w), video digitisers, light pens, eeprom erasers etc.

BE SURE TO WRITE OR PHONE FOR YOUR COPY NOW

CROFTON ELECTRONICS

01-891 1923

35 GROSVENOR ROAD, TWICKENHAM, MIDDLESEX TN1 4AD.

RUGBY TIME?

MSF CLOCK is EXACT

- 8 DIGIT display of Date, Hours, Minutes and Seconds.
- SELF SETTING at switch-on, never gains or loses, automatic GMT/BST and leap year, and leap seconds.
- EXPANDABLE to Years, Months, Weekday and Milliseconds, and use as a STOPCLOCK to show when something happened.
- COMPUTER or ALARM output also, parallel BCD (including Weekday) and audio to record and show time on playback.
- DECODES Rugby 60KHz atomic time signals, superhet receiver (available separately), built-in antenna, 1000Km range.
- FUN-TO-BUILD kit £79.70 includes ALL parts, 5x8x15cm case, pcb, by return postage etc and list of other kits.

CAMBRIDGE KITS

45 (FS) Old School Lane, Milton, Cambridge.

1/2 PRICE LCD DMM WITH CARRY CASE

EXCLUSIVE WHILE STOCKS LAST

- 3½ DIGIT ■ 26 RANGE
 - AUTO ZERO ■ AUTO POLARITY
 - AC/DC 10 AMPS ■ TEST LEADS,
- CARRY CASE, BATTERY & INSTRUCTIONS
5 ranges AC/DC volts 5 ranges AC/DC current
6 ranges Resistance to 20 meg ohms
Size: 161 x 87 x 25mm

£33.95
INC. VAT

List price £71.30
(UK C/P & ins. 85p)
Allow 10 days for delivery

AUDIO ELECTRONICS
301 Edgware Road, London,
W2 1BN 01-724 3564

ORDER BY POST OR PHONE OR CALL IN OPEN 6 DAYS A WEEK

"Rugby"

Controlled Clock



PART 2 - Stephen Ibbs

CONSTRUCTION

A double-sided p.c.b. has been designed for the Decoder to overcome the need for the prolific wire links that would otherwise have existed.

The component layout is shown in Fig. 6. Through board connections are made by soldering the relevant i.c. pin on both sides. If readers are unsure about doing this, it is recommended that 'Soldercon' pins be used as they can easily be soldered on both sides, and the i.c.s then inserted. Any pad or i.c. hole that has a track running to it on the top side should be soldered on both sides.

The Receiver board shown in Fig. 7 is again double-sided. Note that again any leads going to earth should be soldered on both sides. This includes the appropriate i.c. pins, and if 'Soldercon' pins are used, make sure they don't short out onto the earth-plane. The same warning should also be noted for any component lead, and the wire link should be with insulated lead.

Mount the components on the power supply board, Fig. 8, making sure the tantalum capacitors are the correct way round. The prototype had the regulator bolted down onto the board, but it might be a wise precaution to include a small finned heatsink as well. A 20mm fuseholder was mounted on the rear panel as was the transformer.

The aerial requires careful construction. The prototype used a 10mm diameter, 200mm length of F14 ferrite (Maplin), onto which was wound a total of 400 turns, s.w.g. 40 wire in two layers of 200, occupying approx. 1½ inches in the centre of the rod. This is time-consuming by hand, so an electric drill with very slow speed controller was used. The ferrite rod was placed in the chuck, the wire attached, and then fed on as the drill bit turned. (A white spot of paint helped the rotational count.) After completion, the ends of the wire were cleaned, using very fine glass-paper, and connected to the receiver.

The display p.c.b., Fig. 9, has been designed to cater for the AEG/Telefunken displays, 4 yellow ones for the date and seconds, and 4 green for the hours and minutes. Because the clock is deliberately non-multiplexed, several interconnections are needed for the displays. Ribbon cable was used to make possible fault-tracing easier. Pads have been included on the display p.c.b. for seven extra l.e.d.s, a resistor, wire link and interconnecting pads for the 'day option' . . . to be described later. However, if readers do not wish to include this, these pads are simply ignored, and the cutting details should be modified appropriately to make the whole display central. In the prototype, yellow and green filters were stuck behind the apertures to improve the contrast. Please note that the pin-outs for the 4511 and 4026 are different. Also the driving capabilities are slightly different, resulting in the seconds displays being not quite so bright. This can be compensated for either by using two layers of filter for the date digits, or by slightly increasing the value of

the current-limiting resistors for the date display to reduce its brightness, thus balancing the seconds display. The p.c.b. has a small break in the 0V track from the two 'date' digits, and a 33 ohm resistor placed across it.

ALIGNMENT

Imagining the aerial to be a fluorescent tube, align it so that it would if possible light up Rugby, i.e. horizontal, and broadside on. Monitor pin 8 of IC1 on a scope, and by adjusting C3, it should be possible to see the carrier pulsing at 1Hz rate. Adjust L2 to get the maximum pk-to-pk waveform and with VR1 fully clockwise and a lot of luck pin 12 of i.c. will start pulsing low to high. If it doesn't, it means that you almost certainly have too many turns on the aerial, and some must be removed . . . e.g. 15 at a time. The recovered signal will gradually increase in amplitude, and eventually pin 12 will start pulsing. Readers are advised not to compensate by increasing C1 to bring the tuned circuit to resonance. It is a fairly high 'Q' circuit and a low L, high C ratio may not provide sufficient signal. The emitter of TR1 should show a signal similar to that in Fig. 3.

For readers without access to an oscilloscope, setting up is far more awkward. There should be approx. 100mV p/p at pin 8 of IC1 and there needs to be at least 1V p/p at the emitter of TR1. There are other receivers on the market that will also work with the decoder, and if readers do not wish to wind their own aerial, it is recommended that the 'Circuit' receiver kit be built, and its output connected direct to pin 13 of IC1d on the logic board.

After checking several times, particularly to see that all through board connections have been made, connect the output of the receiver to pin 13 (IC1d) and then switch on. Monitor pin 13 of IC4 which should go high and low, depending on the width of the Rugby pulse. If it stays high for at least 20 secs. then R2 is too high (causing the 150ms monostable to last too long), and should be reduced. Similarly, if pin 13 stays low all the time, then R2 is too low and should be increased. These variations are due to the unpredictable nature of capacitance values. Take time with these adjustments; don't forget that secs. 1-16 will be low anyway.

Once the correct value has been found, any '1's or '0's occurring should then clock through the eight outputs of each 4015 in the order: pin 13, 12, 11, 2 (and 7, connected together), 5, 4, 3 and 10 (connected to pin 15 of the next i.c.). Monitor pin 13 of IC3 and check that it goes low on the 60th sec., and that pin 4 of IC2 goes high at the same time. (Note it requires the last few seconds prior to the 60th sec. to receive the framing pattern.)

If all is functioning properly, the display will probably be displaying rubbish, but with the seconds display counting upwards. Table 1 shows that it requires 30 secs. to receive all the necessary data, at which point the display, on the

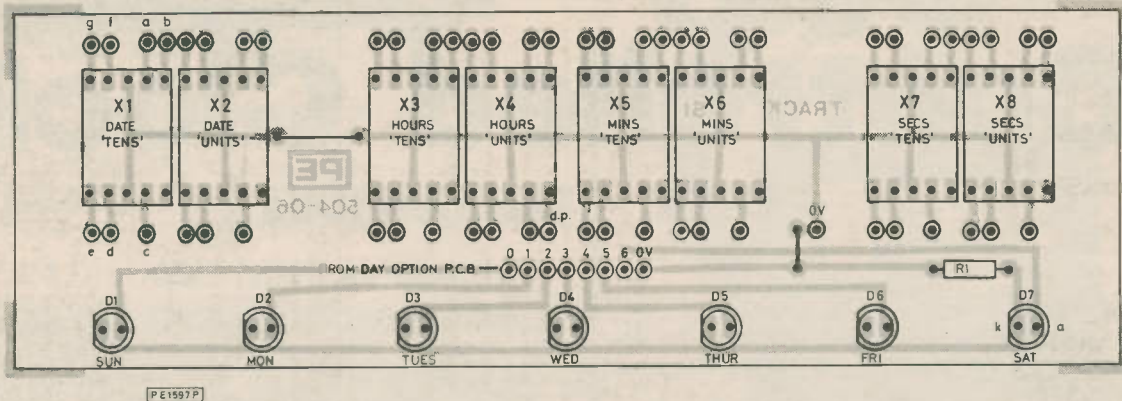

Fig. 9. Component layout of the Display board

60th sec., should leap into action with the correct information, and the secs. display should reset to zero and start counting up.

Assuming all is well, the case can be re-assembled. The prototype had the power supply mounted on the rear panel, with three wires (twin audio lead plus earth) led out for the receiver which was placed a short distance from the case. A 3.5mm stereo jack plug and socket (mounted on the rear panel), was used to connect the receiver to the main unit. The placing of the receiver away from the clock is important, because the metal of the Vero case will change the inductance of the tuned circuit. If a plastic case is used instead it should be possible to place the receiver inside the case, provided it is mounted away from the transformer.

Finally, don't place the clock too close to, e.g., TV's because the RF noise they generate can interfere with, and overload, the receiver. This will cause no pulses to reach the logic board, and the display will freeze. If the unit appears to count properly, but goes erratic when the display lights, it

probably means that the power supply is not steady enough and needs to be up-rated.

DAY OPTION

To light up one of 7 l.e.d.s to show the day, it is necessary to save the 3-bit code from IC6, pins 4, 3, 10, weighted 1, 2, 4 binary, respectively. The simplest way of doing this is shown in Fig. 10 with a 4029 pre-settable up-down counter. The same job could have been performed, of course, with another 4008, but the 4029 is cheaper. Its counting facility is disabled by earthing the 'clock' pin, and the 3 binary lines are connected to three of the four pre-set inputs, the fourth, pin 3, going to earth. The '60th sec.' pulse from IC2, pin 4, is used to load the data into the outputs of the 4029, and these in turn feed the three input lines of a 4051. This converts the 3-bit code so that only one of the 7 outputs goes high, driving the appropriate l.e.d., current limited with 150 ohms. (Note '0' = SUN, '6' = SAT.)

RUGBY CODED SIGNAL																																			
CODE:	D.U.T. CODE							YEAR					MONTH																						
SEC.:	1	2	3	4	5	6	7	8	9	10	11	12	13	14	15	16	17	18	19	20	21	22	23	24	25	26	27	28	29						
BIN. (BINARY)	(see below)																8	0	4	0	2	0	1	0	8	4	2	1	1	0	8	4	2	1	
								1	0	0	0	0	1	0	0	0	0	1	1	1															
CODE:	DATE				DAY				HOUR				MINUTES					FRAME																	
SEC.:	30	31	32	33	34	35	36	37	38	39	40	41	42	43	44	45	46	47	48	49	50	51	52	53	54	55	56	57	58	59	60				
BIN.:	2	0	1	0	8	4	2	1	4	2	1	2	0	1	0	8	4	2	1	4	0	2	0	1	0	8	4	2	1	1	1	1	1	1	0
	1	0	1	0	0	1	1	0	1	0	1	1	0	0	0	1	0	0	1	0	0	0													
																	F	A	S	T	C	O	D	E											

Demonstration time = 18:48 Friday 29th July '84. This would then be displayed on the 60th sec. [Time is transmitted during previous minute, so that on the 60th sec. (i.e., 0 sec.), it is accurate.]

Table 1

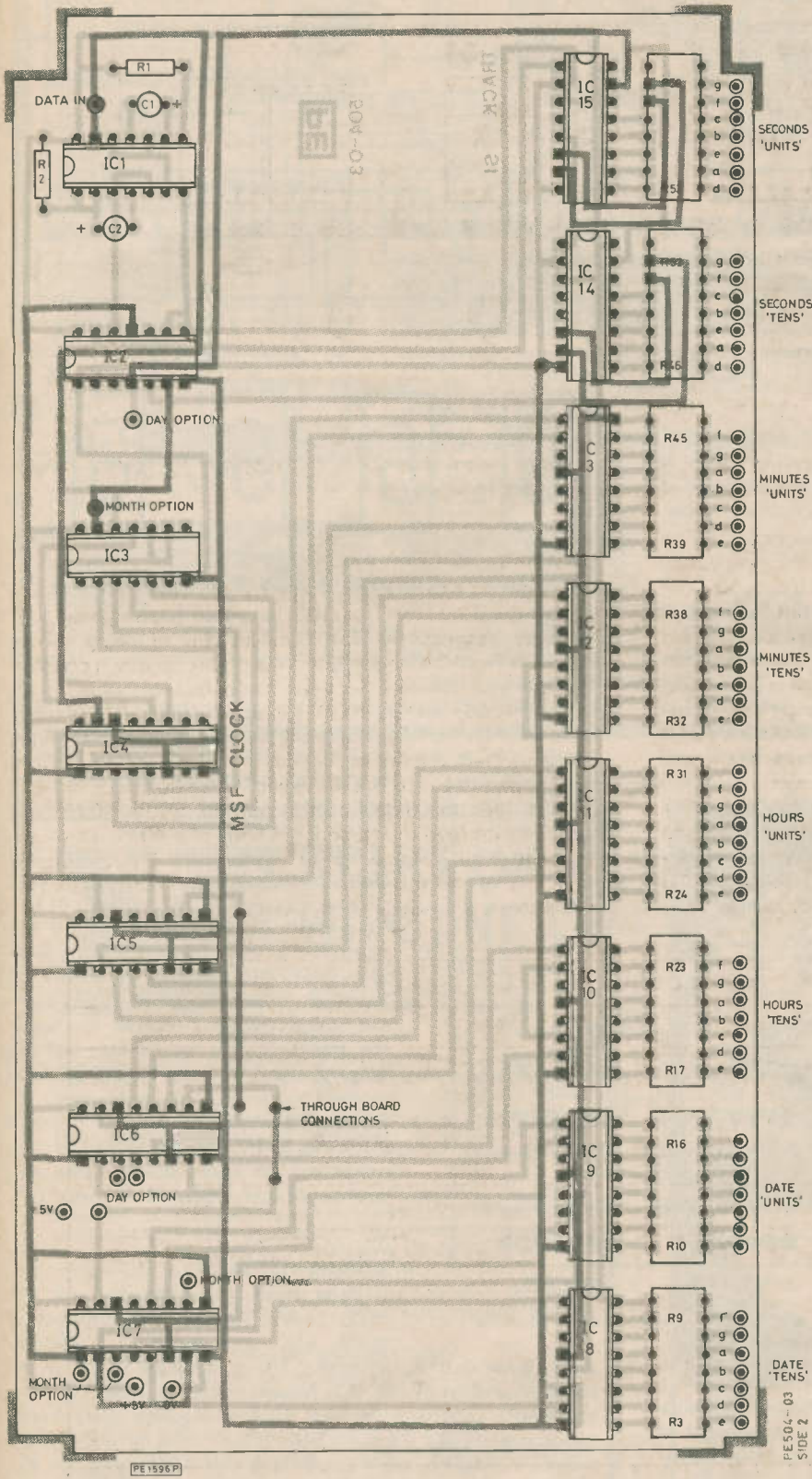

Fig. 6. Component layout of the Decoder board

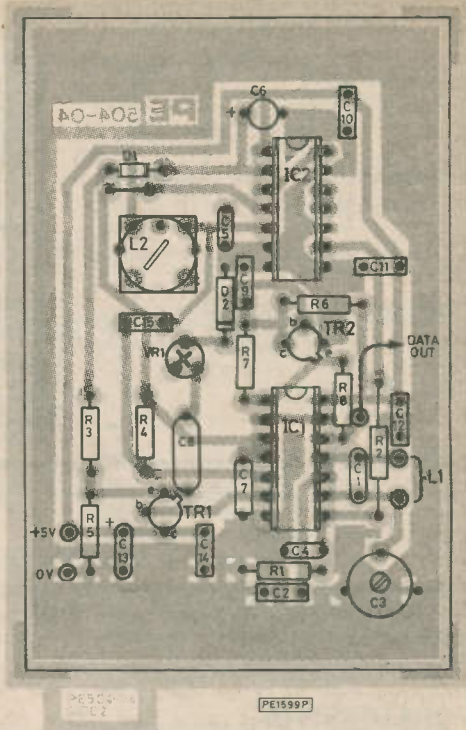

Fig. 7. Component layout of the Receiver

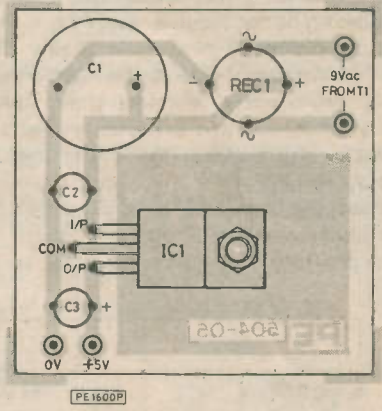

Fig. 8. Component layout of the p.s.u.

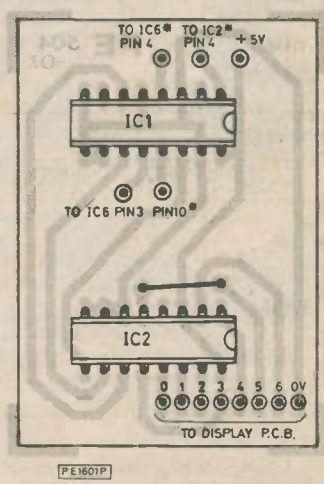

Fig. 11. Component layout of the 'Day option'. *Note: IC2 and 6 are in the Decoder board.

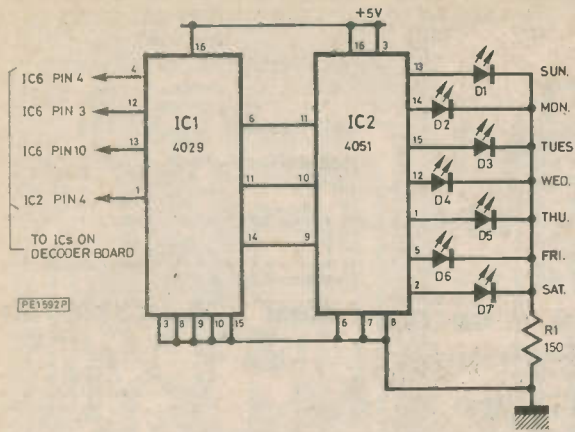

Fig. 10. Circuit diagram of the 'Day option'

YEAR	PIN
1984	6 to +V
2000	6 to 0V
2020	1 to +V
2040	2 to +V

Table 2

CONSTRUCTION

A separate p.c.b. has been designed, and this is shown in Fig. 11. This is connected to the main board by:

- a 5-way ribbon cable for +ve, 3 binary lines, and the pulse from IC2, and
- an 8-way ribbon cable to the display board for the seven i.e.d.s and 0V. The p.c.b. can be mounted on the rear inside panel. Insert the i.e.d.s the correct way round and

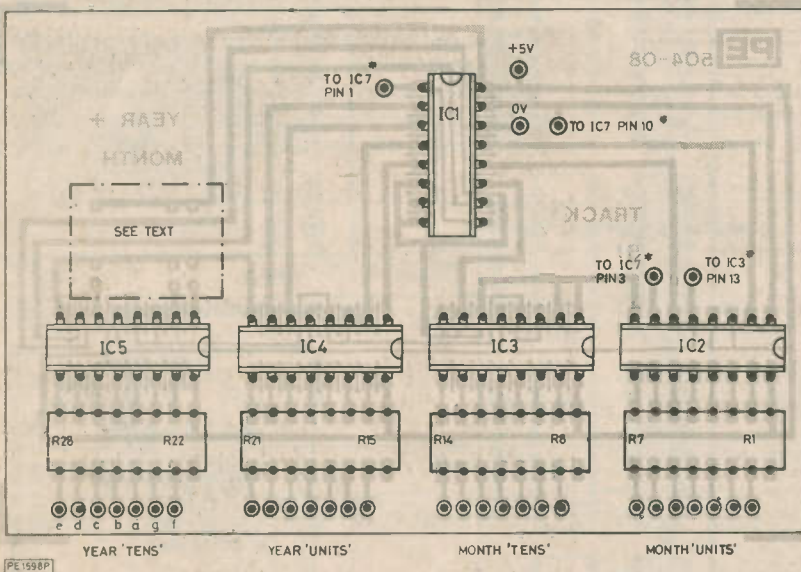

Fig. 13. Component layout of the 'year and month option'. *Note: IC3 and 7 are on the Decoder board

mount on the front panel using clips before final soldering, so that the spacing can be checked. Don't forget the wire link and resistor on the display board. No alignment is necessary, and on reception of accurate data, the appropriate i.e.d. should light.

YEAR AND MONTH OPTION

For those readers who want as much information to be displayed as possible, a month and year board has been

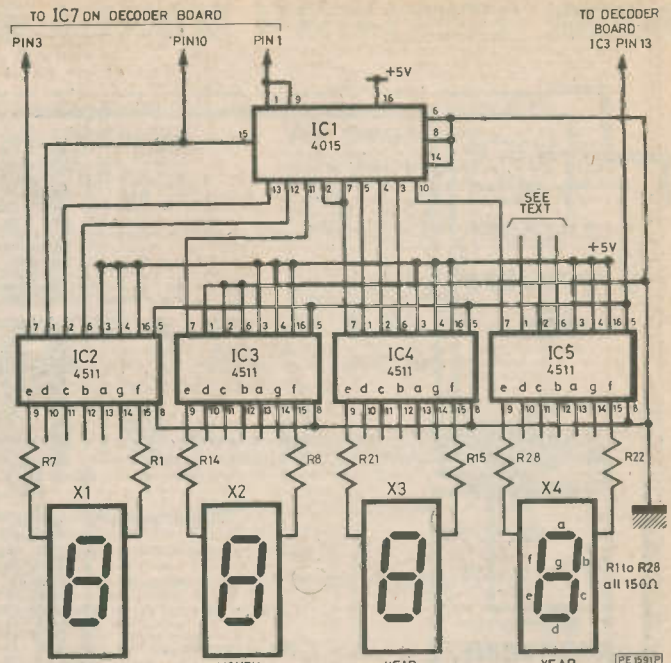

Fig. 12. Circuit diagram of the 'year and month option'

designed as an add-on to the main clock (Fig. 12). Construction details are left to individuals, as probably a different case will be used.

By adding one more 4015 we get access to another 8 of the data pulses from Rugby. Pins 3 and 10 of IC7 already contain part of the month code, and so what will be missing is the final information concerning the year 'tens'. This problem is overcome by using small jumper leads.

Table 1 shows that the month and year information is sent during seconds '17' to '29', and so the majority of this data (secs. 20-27) is stored on the extra 4015, with secs. 28 and 29 on pins 3 and 10, respectively, of IC7 on the main board. The i.c. is linked up to the rest of the shift register in exactly the same way as the others, and the outputs feed into the display drivers, again 4511s. The data from secs. 17, 18 and 19 is missing, so pins 1, 2 and 6 of the 4015 are tied to 0V or +ve according to Table 2. Any pins not connected to +ve should be tied to 0V.

CONSTRUCTION

Pads have been provided on the main board for the interconnecting leads, and once more, d.i.l. resistor packs were used for neatness. The component layout of the p.c.b. is shown in Fig. 13. Mount the i.c.s, checking their orientation, and then connect the four displays using ribbon cable, exactly like the main board. Just to be different, red 7 segment displays were used from the AEG range for the prototype, and no alignment or adjustment should be necessary. One word of warning, however. Because another four displays are being driven, make sure that the power supply has enough current-driving capability, as a poorly regulated supply might upset the receiver. ★

★ ★ NI-CAD BARGAINS ★ ★

Ex-equipment, guaranteed 100%, re-chargeable nickel-cadmium batteries. **VASTLY REDUCED.**
 Type DEAC 1000DK Button Stacks. 6 cells (7.2V) Capacity 1Ah. Measures 2 1/4 x 2" Diameter. £3.00 each inc. VAT (p&p 25p).
 Type DEAC 500DKZ Button Stacks. 3 cells (3.6V) Capacity 600mAh. Measures 1 1/4 x 1 1/4" Diameter. £1.50 each inc. VAT (p&p 25p).



★ ★ STEPPER MOTORS ★ ★

Brand new stock of 'ASTROSYN' Type 20PM-A05 stepper motors. 28V DC. 24 steps per rev. 15 oz in torque @ 100RPM. Body length 2 1/2". shaft 1/8" diam x 1/8" spirally threaded. Weight 16oz. Price each £11.50 (p&p 50p). Connections supplied. INC. VAT.

★ ★ PANTEC 'BANANA' MULTI-METERS ★ ★

We are stockists of the Panteo range of instruments including the famous 'BANANA' Meter illustrated. FULL ONE-YEAR GUARANTEE. LOWEST U.K. PRICE only £25 inc. VAT and carriage. (Send s&e for full details). Brief spec as follows: 20kOhm/V DC. 10kOhm/V AC. Resistance x1, x10, x100ohm, 5 range DCV, 3 range ACV. DC 1 to 2.5A.



★ ★ OPTICAL ISOLATORS ★ ★

SPERRY UNIVAC M4000 opto-isolator units providing 2KV of insulation between Modems and Terminals. 25 way 'D' connectors (RS232C Interface) in and out. Measures 9x5x5". Complete with handbook. £16.50 inc. VAT & p&p.

★ ★ BECKMAN TURNS COUNTER DIALS ★ ★

Miniature type (22mm diam). Counting up to 15 turn 'Helipots'. Brand new with mounting instructions. Only £2.50 each inc. VAT & p&p.

★ ★ CROSS-HATCH GENERATORS ★ ★

LABGEAR COLOURMATCH CM6004PG. UHF television pattern generators giving cross-hatch, dot and grey scale patterns. Fully tested and guaranteed. NOW JUST £20 inc. VAT & p&p.
 LABGEAR COLOURMATCH CM6010RG Gated Rainbow colour pattern generators. Cross-hatch/dot and gated rainbow (RGB) colour bar patterns. £55 inc.
 UNADHM E0654 PAL Colour-bar & pattern gen. £275 +
 KORTING 82512 PAL/NTSC Colour & pattern gen. £275 +
 Mail Order customers please add £2.50 postage each item.



RALFE ELECTRONICS
 10 CHAPEL STREET, LONDON, NW1 TEL: 01-723 8753

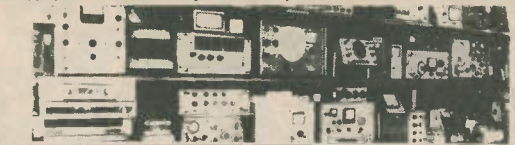

★ ★ OSCILLOSCOPES ★ ★

HEWLETT-PACKARD 141A Storage Oscilloscope.
 HEWLETT-PACKARD 1707A dual trace 75MHz £750
 TEKTRONIX 454A dual trace 150MHz sweep delay £950
 TEKTRONIX 453 dual trace 50MHz sweep delay £600
 TELEQUIPMENT D75 dual trace 50MHz sweep delay £450
 SONY/TEKTRONIX 335 dual trace 35MHz portable.
 TEKTRONIX 7704 frame and plug-in units.
 TELEQUIPMENT DM63 15MHz STORAGE

★ ★ 1KW POWER AMPS ★ ★



H&H PROFESSIONAL AUDIO POWER AMPLIFIERS MODEL S5000 available from stock in little used condition at vastly reduced price. Specification includes: Two channel 500+500W. Distortion 0.005%. Output Z: 2V-16ohms. Frequency response ±1db 10Hz-20KHz. These amplifiers are currently configured as bridge-mode mono 1000W/19" rack-mounting. 3/2" High. 40lbs.
 PRICE JUST £275 inc. VAT. (p&p £5).

★ ★ 125W MAINS INVERTERS ★ ★

12V DC Battery Input to 230V AC. Output @ 125 watts crystal-controlled 50Hz time-base oscillator, fully enclosed in blue-steel cases with integral 13A socket. Dimensions approx. 4 x 6 x 10". BRAND NEW. £60 inc. VAT and carriage.

★ ★ COUTANT LINEAR POWER UNITS ★ ★

Model ASA2000. 240V AC Input to 5V 20A Output £35 inc. VAT
 Model ASC30025. 240V Input to 24V Output £20 inc. VAT
 (Carriage £4 and £2 respectively)

★ ★ MAINS STABILISERS ★ ★

Small quantity available of brand-new Gould ECVN250A constant voltage transformers. 190-250V AC input to 240V AC output @ 250 watts. £45 each + VAT (p&p £3).

★ ★ SWEEPERS ★ ★

TELDNIC 2003 System. 800-1500MHz £325
 TELDNIC SM2000 with 500-900MHz plug-in £175
 KNIGHT KG-687 3-220MHz £150

★ ★ TEKTRONIX ★ ★

FILE MANAGER SYSTEM MODEL 4507 Option 31 (Third disc drive). 4051 Graphic System compatible. GPIB (IEEE 488-1975) compatible.

PLEASE NOTE: All the pre-owned equipment shown has been carefully tested in our workshop and reconditioned where necessary. It is sold in first-class operational condition and most items carry a three months' guarantee. For our mail order customers we have a money-back scheme. Repairs and servicing to all equipment at very reasonable rates. PLEASE ADD 15% VAT TO ALL PRICES. EQUIPMENT WANTED.

★ ★ COMPUTER PERIPHERALS ★ ★

★ ★ 1.6MB 8" FLOPPY DISC DRIVES - New Stock ★ ★

BRAND-NEW AT SURPLUS PRICE. Fully Shugart compatible 'MFE CORPORATION' Model M-700 DOUBLE SIDED industry standard 8" floppy disc drives. Double-density up to 1.6MBytes. Power requirements ±5V and +24V @ 1.1A. 240V/50Hz. LOWEST PRICE EVER - £160 inc. VAT, CARRIAGE & HANDBOOK.

★ ★ DRE 4000A DISC DRIVES ★ ★

Data Recording Equipment Model 4000A. 5+5MB Top-loading disc drives in stock. Brand new including full technical manual. Few remaining £250 each + VAT.
 SHUGART 8" Flexible disc drives model SA800. Condition as new £150 + VAT. (Including postage and handbook copy).

★ ★ MULTI-RAIL LINEAR PSU's ★ ★

Recent stock of brand new COUTANT ESM-Series Power Supplies at surplus prices. Model ESM15.2 giving regulated, stabilised DC outputs 5V @ 15A and ±12V to ±15V @ 1.5A each and an un-stabilised 24V @ 2A. 240V AC input. Measures 5x8x11". Fully enclosed. In original cartons with handbooks. £45 each + VAT (p&p £2).

★ ★ SWITCH MODE POWER SUPPLIES ★ ★

Fully tested and guaranteed PSU's now at LOWEST EVER PRICES. Manufactured by FARNELL, GOULD/ADVANCE.
 5V @ 10 amps £18 12V 16A (110V in) £20
 5V @ 20 amps £20 5V @ 60 amps £35
 19V @ 15 amps £35 12V @ 15 amps £40
 All prices now include VAT, packing and posting.

★ ★ CENTRIFUGAL BLOWERS ★ ★

TORIN Type U62B1. 230V Cap/Start (supplied), very powerful (200W, 3,000 rpm) centrifugal fans for large rack cooling or enclosure extraction applications. Overall dimensions 20x12 cms, outlet 6x4 cms. BRAND NEW. Surplus stock. £15 each inc. VAT, p&p £1.50.

★ ★ INSTRUMENT COOLING FANS ★ ★

Recent stock of BRAND NEW 5-bladed axial cooling fans measuring 3/2" x 3/2" x 1" (slimline fans).
 230V AC 10 watts £7.50
 115V AC 13 watts £6.50
 115V 4 1/2" x 4 1/2" x 1 1/2" £6.00
 Now including VAT (p&p 50p).

THE START OF SOMETHING NEW

If you are leaving College and planning a career in modern communications or if your present job lacks interest and challenge... why not join us in GCHQ? We are recruiting

RADIO OFFICERS

who after initial training will become members of an organisation that is in the forefront of communications technology. Government Communications Headquarters can offer you a satisfying and rewarding career in the wide field of communications. Training involves a 32 week course (38 weeks if you come straight from Nautical College) which will fit you for appointment to RADIO OFFICER.

Not only will you find the work as an R O extremely interesting but there are also good prospects for promotion, opportunities for overseas travel and a good salary. Add to this the security of working for an important Government Department and you could really have the start of something new.

The basic requirement for the job is two years' radio operating experience or hold a PMG, MPT or MRGC or be about to obtain a MRGC.

Registered disabled people are welcome to apply. Salaries start at £4,762 at age 19 to £5,755 at age 25 and over during training and then £6,399 at 19 to £8,510 at 25 and over as a Radio Officer. Increments then follow annually to £11,741 inclusive of shift and weekend working allowances.

For full details and application form 'phone 0242 32912/3 or write to:



Recruitment Office, Government Communications Headquarters, Oakley, Priors Road, Cheltenham, Gloucestershire, GL52 5AJ.

ROBOTS For Education, Training and Industry

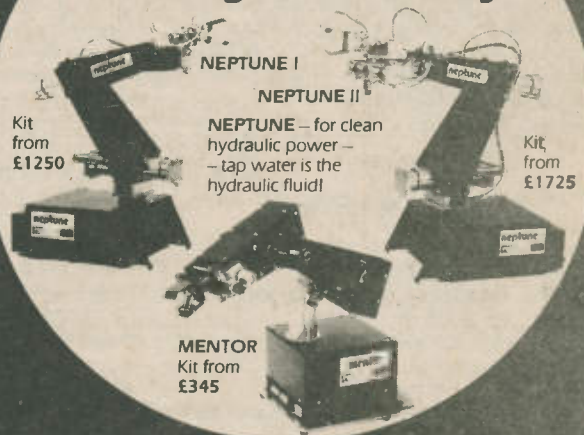

NEPTUNE I
 Kit from £1250

NEPTUNE II
 NEPTUNE - for clean hydraulic power - tap water is the hydraulic fluid
 Kit from £1725

MENTOR
 Kit from £345

NEPTUNE I 6 axes; 8 bit control system; 2.5Kg capacity; 1120mm reach.
 NEPTUNE II 7 axes; 12 bit control system; 2.5Kg capacity; 1120mm reach.
 MENTOR DC servo desktop robot; 8 bit control system; 300gm capacity; 420mm reach.
 Robots programmed from keyboard or hand-held simulator (model robot).

Robots may also be taught by 'lead by the nose' method. Extensive software is supplied free with each robot. Leads available for connection to BBC, ZX Spectrum, Apple IIe, Commodore 64 and VIC 20. Most other micros are also easily usable with these robots. Robots also available ready built.



Please phone for brochure: 0264 50093. West Portway Industrial Estate, Andover SP10 3PE. A private and independent company giving prompt, personal service.

THE LEADING EDGE

RADIATION SHIELD

The danger from within. What danger? Chichester firm Rolenworth International recently published a glossy brochure entitled "The Danger from Within" which refers to the "ever present risk of microwave radiation" from VDU. It was of course a sales pitch. Rolenworth sell a "Microshield" smock to protect against microwaves.

According to the brochure "one feature all VDU's have in common is that they emit microwave radiation—which is believed to be harmful to the body". The brochure then reproduces alarming quotes from publications as diverse as the Santa Cruz *Sentinel*, *Computer News*, and *Wall Street Journal*.

"Eight out of ten women working with VDU's in a Danish library had miscarriages"; "Studies show a disturbing correlation between birth defects and the use of VDUs"; "Half the pregnancies among women working at VDUs in a United Airlines Office ended in miscarriages, newborn deaths or other problems".

But never fear. "New Microshield is a lightweight smock that virtually eliminates the risk of microwave radiation reaching the operator . . . Microshield also provides protection against ambient radiation—the sort of radiation that seeps from the backs and sides of terminals . . . No VDU operator should work without one."

The smock, which covers the body from neck to knee, but not the arms, is made from a Japanese material which fuses polyester fibre to a nickel membrane. Rolenworth say this membrane is "just millimicrons thick" but I find this hard to believe. A micron is one millionth of a metre, so a millimicron is 10^{-9} or one thousandth of a millionth of a metre. That's the wavelength of ultraviolet light.

RADIATION LEVELS

Be that as it may, Rolenworth says the material "reduces by as much as 99.9 percent the amount of microwave radiation reaching the body of the VDU operator". Also, according to Rolenworth, "microwave radiation is known to be given out by modern office electronic equipment".

I am sure that the nickel, however thick or thin, does as claimed and reflects microwave radiation back to its source. The National Radiological Protection Board (NRPB) agrees, but makes the passing point that if the smock is giving protection against high level radiation there could be 'arcing' at the edges. If the equipment is sensitive the reflections could upset it.

Rolenworth's publicity prompts two questions. How much microwave radiation is emitted by a VDU and is it a proven

health risk? Rolenworth's publicity doesn't answer these questions.

I specifically asked the company if they could cite me any medical evidence. The best they could do was refer me to an article which appeared in *The Times*. So I did some digging of my own.

SAFE LIMITS

In Britain the "safe limit" for microwave radiation is put at 100 watts per square metre. In Russia the limit is much lower, 50 milliwatts of 0.05 watts per square metre, but with workers allowed to take double the dose.

The British NRPB is funded half by the Government DHSS and half by private contracts for instance from people as diverse as the Friends of the Earth and Central Electricity Generating Board. The NRPB can measure microwave radiation right down to the Russian limit of 0.05 watts per square metre. Even with equipment of this sensitivity they have been unable to measure any microwave radiation from any VDU.

The NRPB believes that other workers have been able to measure VDU radiation at a signal strength of between 10^{-6} to 10^{-8} watts per square metre, at around $1\frac{1}{2}$ metres from the unit. This would mean that an operator sitting close might be dosed with radiation at about 10^{-5} or 10^{-6} watts per square metre. That is clearly well below even the most stringent Russian regulations.

This low level is not so surprising. A VDU is really just a television set. The only source of high frequency radiation, in the microwave band, would be harmonics from the line scan coils which, for European TV sets, are running at 15.625kHz. To get into microwave band, the harmonics would have to be very high and thus very weak.

In the early days of colour TV there was a similar scare about supposed risk from X-rays. This kind of radiation is created whenever any high voltage beam is decelerated. The 25 kilovolt electron beam in a TV set or VDU inevitably emits X-rays when it is stopped by the glass at the front of the picture tube. But the X-rays are absorbed by the glass. When the NRPB tried to measure this radiation, they found that what they were measuring came from the potassium isotope which is a natural component of all glass!

Needless to say the NRPB is very, very sceptical about the Rolenworth publicity. "We are concerned because the claims seem exaggerated and may cause undue worry amongst VDU operators" says Dr. John Dennis, an Assistant Director of the NRPB. "We have received letters from worried VDU users about talk of microwave risk. The worry itself could cause a miscarriage".

ABORTED TEST

I checked *The Times* article which Rolenworth quoted to me. It appeared on November 16, 1984 and referred to a study of pregnancies amongst female staff at the Department of Employment in Runcorn, Cheshire.

This study has quite a history. It was not a full study. It was a pilot test on a questionnaire. They were testing the questionnaire before starting a full study.

The figures that emerged were so odd that they abandoned the questionnaire. For instance although the study suggested that female VDU operators at Runcorn were having more miscarriages and still-births than the national average, it also suggested that the people at the same Runcorn office who did *not* work with VDUs, were having far fewer miscarriages and still-births compared with the national average.

There is a department inside the Government Treasury called The Computer and Telecoms Agency. It deals with the purchase of technical equipment for use by civil servants. Needless to say they worry a lot about whether anything they buy is risky, because if it is there could well be massive claims for compensation from the civil service unions.

Usually government departments are ambiguous when they offer a quote. But not so the CCTA over VDUs. "The CCTA advice, formed by discussions with the Civil Service medical advisory service, is that wearing anti-radiation smocks is unnecessary for VDU operators and only liable to promote unjustified fears. If there were a radiation risk the appropriate response would be to make the equipment safe, not to issue operators with shielding garments.

However, no survey has ever detected significant levels of microwave radiation from a VDU and the insignificant levels which may be determined are orders of magnitude below levels associated with biological damage. There is no health risk from microwave emission from VDUs"

Rolenworth warns in its literature that "While no legislation exists as yet concerning occupational safety for VDU operators, change is imminent . . . anyone operating a VDU without Microshield is running a risk." My researches show that there is no reason to suppose that legislation is imminent; there is no scientific evidence to support the claim that VDUs emit measurable quantities of microwave radiation; and there is no good medical evidence to suggest that what tiny amount of radiation is emitted can cause unnatural pregnancies.

If there is a risk, it is more likely to be caused by the unnatural strain and stress of working from screen rather than paper.

BARRY FOX

PRACTICAL ELECTRONICS PRINTED CIRCUIT BOARD SERVICE

Printed circuit boards for certain PE constructional projects are now available from the PE PCB Service, see list. They are fully drilled and roller tinned. All prices include VAT and postage and packing. Add £1 per board for overseas airmail. Remittances should be sent to: **PE PCB Service, Practical Electronics Editorial Offices, Westover House, West Quay Road, Poole, Dorset BH15 1JG.** Cheques should be crossed and made payable to IPC Magazines Ltd.

Please note that when ordering it is important to give project title, order code and the quantity. Please print name and address in Block Caps. Do not send any other correspondence with your order.

Readers are advised to check with prices appearing in the current issue before ordering.

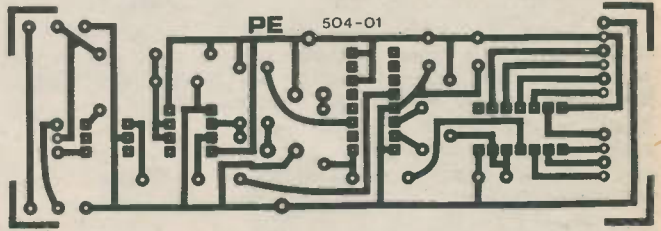

NOTE: Please allow 28 days for delivery. We can only supply boards listed here.

PROJECT TITLE	Order Code	Cost
FEB '81		
Slave Light Dimmer	102-01	£1.88
MAR '81		
27/28MHz Converter	103-01	£1.79
Microphone Mixer	103-02	£1.83
Period Power Tester	103-03	£2.25
APRIL '81		
Speech Processor	104-01	£1.55
Mini Drill	104-02	£1.50
MAY '81		
Digisounder	105-01	£6.65
Thermometer	105-02	£1.49
JUNE '81		
pH Meter	106-01	£2.06
SEPT '81		
Horologicum	109-01	£3.16
"	109-02	£3.11
"	109-03	£2.97
Analogue Frequency Meter	109-04	£2.87
Ignition System	109-05	£2.47
"	109-06	£2.28
APRIL '82		
Med. Resolution Equaliser (UK 101)	204-01	£1.73
Enlarger Timer	204-02	£4.02
AUG '82		
Automatic Photographer	208-01	£1.94
Home Alarm	208-02	£3.21
JAN '83		
Audio Booster	301-01	£3.32
FEB '83		
Radio Booster	302-02	£1.80
MAR '83		
Into the Real World	303-01	£3.99
Accessory PSU	303-02	£1.35
4½ Digit Frequency Meter	303-03	£3.69
JUNE '83		
Program Conditioner	306-01	£2.30
SEPT '83		
Guitar Active Tone Control	309-01	£2.27
Ground Communication System	309-02	£2.13
"	309-03	£2.31
DEC '83		
Expanding the Vic 20	312-01	£5.18
FEB '84		
Temp. Controller	402-04	£1.85
"	402-05	£2.61
MAR '84		
Spectrum Autosave	403-01	£1.83

PROJECT TITLE	Order Code	Cost
MAY '84		
Sustain Unit	405-02	£2.82
Audio Signal Generator	405-03	£4.28
"	405-04	£2.51
JULY '84		
EPROM Duplicator	407-02	£3.74
Alarm System	407-03	£3.19
Oscilloscope Calibrator	407-04	£4.23
AUG '84		
Comm. 64 RS232C Interface	408-01	£3.02
Field Measurement	408-02	£3.19
"	408-03	£2.76
Simple Logic Analyser	408-05	£2.93
SEPT '84		
Parallel to Serial Converter	409-01	£2.92
Through the Mains Controller	409-02	£2.88
"	409-03	£2.71
OCT '84		
Logic Probe	410-01	£1.90
NOV '84		
Computer DFM Adaptor	411-01	£2.76
DEC '84		
Ni-Cad Charger	412-01	£2.40
JAN '85		
Outrider Car Computer (Set of 2 boards)	501-01/2	£9.10
FEB '85		
Modular Audio Power System		
Pt-1: Power Amp Board	502-01	£4.19
Spectrum DAC/ADC Board	502-02	£3.69
MARCH '85		
Modular Audio Power System		
Pt-2: Pre-Amp/Line Driver	503-01	£5.00
Main Board	503-02	£5.12
Heart Beat Monitor		
Detector	503-03	£8.90
Main Circuit Board	503-04	£6.62
Low Cost Speech Synthesiser	503-05	£3.42
APRIL '85		
Power Control Interface	504-01	£3.36
Disc Drive PSU	504-02	£6.54
Modular Audio Power System		
Pt-3: Test Signal Source	504-09	£4.20
Power Supply	504-10	£4.17
MAY '85		
Amstrad Synthesiser Interface	505-01	£4.23
Rugby Clock Pt-2	504-03	£24.22
"	504-04	£9.06
"	504-05	£5.12
"	504-06	£9.54
"	504-07	£5.40
"	504-08	£10.24

MAKE A GOOD FRIEND OF YOUR MICRO

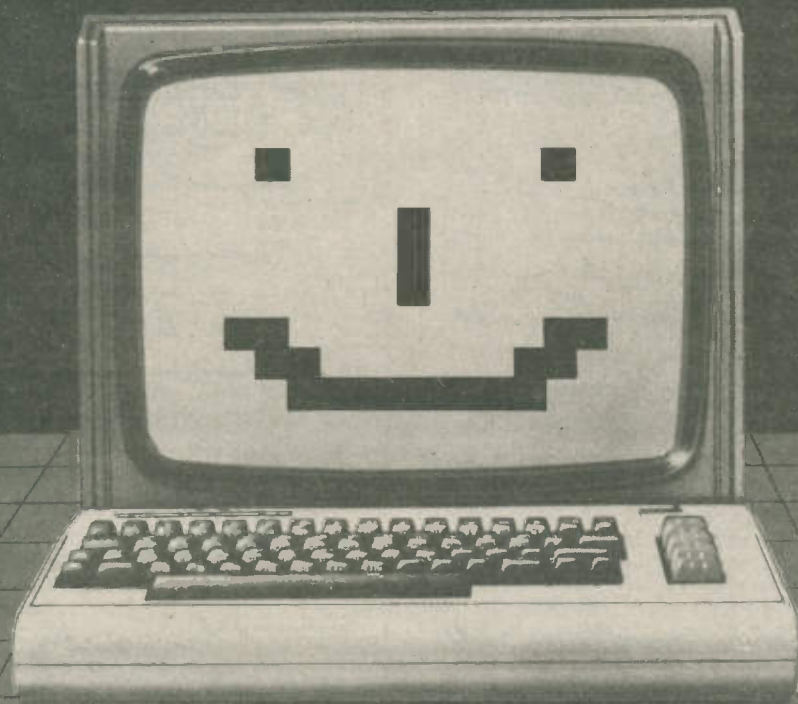

Are you feeding it the right sort of software? Otherwise you won't be getting the service you deserve. See **SOFTWARE INDEX** for the info and data you need on the full range of programs now available for these five top micros.

**BBC COMMODORE 64 SPECTRUM
AMSTRAD CPC 464 MSX MACHINES**

**OVER
4,000
PROGRAMS**

The most comprehensive guide to software programs

SOFTWARE INDEX

No 6-OUT NOW £2.00

GAMES • EDUCATIONAL • BUSINESS • PERSONAL MANAGEMENT • UTILITY • MISCELLANEOUS

FOR QUALITY COMPONENTS
BY MAIL ORDER

ELECTROVALUE

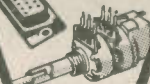
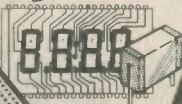
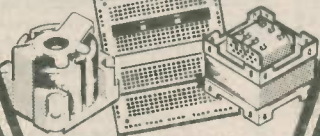

**FREE
44 PAGE
PRICED AND
ILLUSTRATED
CATALOGUE
ON REQUEST**

**FREE POSTAGE
GOOD DISCOUNTS
GOOD SERVICE
THOUSANDS OF
STOCK ITEMS
PHONE YOUR ORDER
ACCESS OR
BARCLAYCARD**

ELECTROVALUE LTD 28 St. Jude's Road, Englefield Green, Egham,
Surrey TW20 0HB Phone Egham (0784) 33603. Telex 264475
North Branch, 680 Burnage Lane, Manchester M19 1NA
Phone 061 432 4945
Please mention this publication when replying

NEW THIS MONTH

"SENSING & CONTROL PROJECTS FOR THE BBC MICRO"

Have you ever wondered what all those plugs and sockets on the back of the BBC micro are for? This book assumes no previous electric knowledge and no soldering is required, but guides the reader (pupil or teacher) from basic connections of the user sockets, to quite complex projects. The author, an experienced teacher in this field, has provided lots of practical experiments, with ideas on how to follow up the basic principles. A complete kit of parts for all the experiments is also available. Book, 245x185mm 120pp £5.95. Kit £29.95.

LEADS AT SILLY PRICES!!

PL616 DC adaptor lead for Walkman, 1.8m long 30p.

PL528 2 pin DIN line skt to phono plug 0.2m long 20p.

PL508 5 pin DIN to 3 pin DIN audio lead 1.2m long 40p.

PL541 Intercom extn lead, 3.5mm line skt to 3.5mm plug, 6m long 40p.

PL708 Video lead, PL259 plug to F type plug, 3m low loss coax 85p.

FM TUNING MODULE. This neat unit 75x40x19mm as used in car radios etc. Standard 10.7MHz IF output. 9-12V DC supply. Full connexion data supplied. £2.40.

Stereo Cassette Head. Only £1.00.

1W AMPLIFIER

Z914 - Audio amp panel 95x65mm with TBA820 chip. Gives 1W output with 9V supply. Switch and vol. control. Just connect batt. and speaker. Full details supplied. Only £1.50; 10 for £12; 25 for £25.

AM TUNER PANEL

Z916 - For use with mono amp above. Neat panel 60x45mm. Only £1.50; 10 for £12.00.

PCB MOUNTING NI-CADS

Much sought after 4.8V 150mA batts with PCB mntg tags on 25mm pitch. Batt size 25x16 Ø. Ideal for paralleling. 99p ea; 10+ 85p; 25+ 70p; 100+ 60p.

IEC FILTER PLUG

Made by Rendar, integrated chassis mounted plug with mains filter rated 2A. Like RS 238-514. Only £3.00.

1984/85 CATALOGUE

84 page A4 size - Bigger, Brighter, Better - more components than ever before! With each copy there's discount vouchers, Bargain List, Wholesale Discount List, Bulk Buyers List, Order Form and Reply Paid Envelope. All for just £1.00!! Winter Supplement out Now - Send large SAE for your free copy.

"TREKKER"

Computer-controlled Robot built around the gearbox described below. Complete kit of parts inc PCB, program listings for BBC (other micros soon). £44.85. 20W ribbon cable (min 3m recommended - 5m better) £1.30/m. SAE for illustrated leaflet.

The unit has 2 x 3V motors, linked by a magnetic clutch, thus enabling turning of the vehicle, and a gearbox contained within the black ABS housing, reducing the final drive speed to approx 50rpm. Data is supplied with the unit showing various options on driving the motors etc. £5.95. Suitable. Two new types of wheels can be supplied (the aluminium discs, and smaller plastic wheels are now sold out). Type A has 7 spokes with a round black tyre and is 100mm dia. Type B is a solid heavy duty wheel 107mm dia with a flat rigid tyre 17mm wide.

PRICES: Gearbox with data sheets: £5.95 ea
Wheel type A: £0.70 ea
Wheel type B: £0.90 ea



FIBRE OPTICS
Scoop purchase of single and twin cable. For use with visible light or infra-red. Core 1mm dia, overall 2.25mm dia. Single 50p/m; 20m coil £6.30. Twin 90p/m; 20m coil £11.00.

Official orders welcome - minimum invoice charge £10. No. min. on CWO. Goods normally despatched by return of post. Our store has enormous stock of components and is open from 9.5.30 Mon-Sat. Come & see us!

Minimum Access order £5.00
GREENWELD
443C Millbrook Road Southampton
SO1 0HX Tel (0703) 772501/783740
ALL PRICES INCLUDE VAT. JUST ADD 60p P&P

CATALOGUE PLUS 100 MIXED RESISTORS YOURS FREE

SEE POSTAGE DETAILS BELOW

Catalogue No.	Description	Price
MT 11	Short-Wave Miniature Transmitter	£5.29
A12/BS	Car Alarm System	£5.94
A12/S	- Cabinet	£5.99
A12	- Assembled	£21.85
RT 35	Precision Time Switch	£8.30
AV 300	Antenna Amplifier	£4.11
TT 31	Two-Tone Gong	£5.16
DE 21	LED VU M Tr	£8.92
SD 6	Sensor-Dimmer	£11.21
UW 1054	Universal Preampifier	£8.98
NFV 4W	NFV 4W	£5.29
NFV 8W	8W	£5.31
AV 15	Final Stage Amplifier 15 Watts	£8.30
AV 22	Final Stage Amplifier 22 Watts	£12.56
AV 50	Final Stage Amplifier 50 Watts	£14.61
LNG 33	Power Supply Unit 2-30 V/2A	£15.84
K 13	- Cabinet	£19.55
LNG 44-2	Laboratory Power Supply Unit	£13.28
SM 3 P/BS	4 Channel Sound-to-Light System	£11.27
SM 3 P/G	- Cabinet	£24.62
SM 3 P	- Assembled	£8.62
STO 100	Effects Stroboscope 60 WS	£11.78
STO 200	120 WS	£37.23
C 4000	C-Mos Trainer	£28.57
DS 1000	Disco Stroboscope	£19.90
LL4/BS	4 Channel Running Lights System	£5.25
LL4/G	- Cabinet	£26.51
LL4	- Assembled	£26.51

BARGAINS

VOLTAGE REGULATORS	
1 amp 5v to 220PK	5 for £2.00
1 amp 12v to 220PK	5 for £2.00

Mixed DL Switches up to 8way 5 for £2.00
Shaded Pole Motors - Ideal for Record Players. £2.50 each
3" LED Display 7 SEG £1.00 each
4" LED Display 7 SEG £1.40 each
24 Hour Clock Display Non Multiplex £2.50 each
DPA/MP MC1456 10 for £5.00
100M μ F 250V Radial Electrolytic 100 for £3.00
47 μ F 16V DC Radial 10 for £1.00
5000 μ F 12V Radial 10 for £1.00
1000 μ F 10V DC Radial 15 for £1.00
220 μ F 40V Axial 15 for £1.00
25 μ F 50V Axial 20 for £1.00
47 μ F 63V Axial 20 for £1.00
10 μ F 40V Axial 20 for £1.00
47 μ F 10V Axial 20 for £1.00

SOLDERING INSTRUMENTS

MODEL CS IRON	
17W 240V	£6.75
SK1 COMPLETE SOLDERING KIT	
15W 250V	£10.35
SK5 COMPLETE SOLDERING KIT	
17W 240V Stand & Solder	£9.31
SK6 COMPLETE SOLDERING KIT	
25W 240V	£11.63

MULTIPURPOSE BOXES

Type No	A	B	C	Price
	71 mm	46 mm	22 mm	£0.60
MB1-00	75 mm	56 mm	35 mm	£0.80
MB2-00	95 mm	71 mm	35 mm	£0.95
MB3-00	115 mm	95 mm	37 mm	£1.10
MB3-50	145 mm	95 mm	55 mm	£1.35
MB4-00	207 mm	122 mm	77 mm	£2.20
MB6-00	213 mm	142 mm	57 mm	£2.50

MULTIMETERS

28 ranges. 20kV d.c. & 4kV a.c. (with protective fuse).
Accuracy: 2% d.c. and resistance, 3% a.c.
28 ranges: d.c. V 100m, 3V, 10V, 30V, 100V, 300V, 600V d.c. 150 μ A, 600 μ A, a.c. V 15V, 50V, 150V, 500V, 1500V a.c. 130mA, 30mA, 3.0A Ohms 0-2k Ω , 0-2M Ω , dB from -10 to +62in, 6 ranges.
Dimensions: 105 x 130 x 40mm
With carrying case & Leads
ONLY £21.60

"MINI 20"



BOOKS

190	Circuit Design and Construction Manual	£1.95
202	Handbook of IC Equivalents & Substitutes	£1.95
219	Solid State Novelty Projects	£0.85
221	28 Tested Transistor Projects	£1.25
222	Solid State Short Wave Receivers for Beginners	£1.95
227	Beginners Guide to Building Electronic Projects	£1.95
BP24	52 Projects Using IC741	£1.75
BP44	IC 555 Projects	£1.95
BP48	Electronic Projects for Beginners	£1.95
BP53	Practical Electronics Calculations and Formulae	£2.95
BP56	Electronic Security Devices	£1.95
BP58	50 Circuits Using 7400 Series IC's	£1.75
BP65	Single IC Projects	£1.50
BP74	Electronic Music Projects	£1.75
BP75	Electronic Test Equipment Construction	£1.75
BP80	Popular Electronic Circuits - Book 1	£1.95
BP88	How to Use Op-Amps	£2.25
BP90	Audio Projects	£1.95
BP93	Electronic Timer Projects	£1.95
BP97	IC Projects for Beginners	£1.95
BP98	Popular Electronic Circuits - Book 2	£2.25
BP105	Modern Op-Amp Projects	£1.95
BP110	How to Get Your Electronic Projects Working	£1.95
BP117	Practical Electronic Building Blocks - Book 1	£1.95
BP121	How to Design and Make your Own P.C.B.s	£1.95
BP122	Audio Amplifier Construction	£2.25
BP127	How to Design Electronic Projects	£2.25

ALL PRICES INCLUDE VAT - ALL GOODS BRAND NEW & NORMALLY DESPATCHED BY RETURN POST.
TERMS: Cash with order. POST & PACKING: Please add 95p to all orders including free offers. (Books post free)

AC/DC ELECTRONICS COMPONENTS
DEPT PE, 45 CHURCH STREET, ENFIELD, MIDDLESEX.
DON'T MISS NEXT MONTHS FREE OFFER



When replying to Classified Advertisements please ensure:

- (A) That you have clearly stated your requirements.
- (B) That you have enclosed the right remittance.
- (C) That your name and address is written in block capitals, and
- (D) That your letter is correctly addressed to the advertiser.

This will assist advertisers in processing and despatching orders with the minimum of delay.

FOR SALE

SECONDHAND A.V.O.'s, P.S.V.'s, OSCILLOSCOPES etc. Fully guaranteed. Phone Newent 821930 evenings (Trade).

TEKTRONIC 516 SCOPE £130. Many others £70+. RS232 Printers. VTRS. SINCLARE 01-316 1779.

SERVICE SHEETS

BELLS TELEVISION SERVICES for service sheets of Radio, TV, etc £1.50 plus SAE. Colour TV Service Manuals on request. SAE with enquiries to B.T.S., 190 Kings Road, Harrogate, N. Yorkshire. Tel. (0423) 55885.

RECEIVERS AND COMPONENTS

UNBEATABLE VALUE E12 RESISTOR PACK 1R-10M 850 resistors (85 individual labelled bags) £6.65; 3.68640MHz crystals 50p, Solder 40p/5M, please add 50p postage and VAT for full lists send SAE. JPG ELECTRONICS 276 Chatsworth Road, Chesterfield S40 2BH (0246) 211202.

BOURNEMOUTH/BOSCOMBE. Electronic components specialists for 33 years. FORRESTERS (NATIONAL RADIO SUPPLIES), Late Holdenhurst Road. Now at 36, Ashley Road, Boscombe. Tel. 302204. Closed Weds.

TURN YOUR SURPLUS capacitors, transistors, etc into cash. Contact COLES HARDING & CO., 103 South Brink, Wisbech, Cambs. Tel. 0945 584188. Immediate settlement.

SMALL ADS

The prepaid rate for classified advertisements is 36 pence per word (minimum 12 words), box number 60p extra. Semi-display setting £12.00 per single column centimetre (minimum 2.5 cms). All cheques, postal orders etc., to be made payable to Practical Electronics and crossed "Lloyds Banks Ltd". Treasury notes should always be sent registered post. Advertisements, together with remittance, should be sent to the Classified Advertisement Dept., Practical Electronics, Room 2612, IPC Magazines Limited, King's Reach Tower, Stamford St., London, SE1 9LS. (Telephone 01-261 5846).

NOTICE TO READERS

Whilst prices of goods shown in classified advertisements are correct at the time of closing for press, readers are advised to check with the advertiser to check both prices and availability of goods before ordering from non-current issues of the magazine.

BRAND NEW COMPONENTS BY RETURN

Electrolytic Capacitors 16V, 25V, 50V.
0.47 - 10, 22, 47 & 10 Mfds - 5p.
22 & 47-6p. 100-7p. (50V-8p). 220-8p. (50V-10p).
470-11p. (40V-16p). 1000/15V-15p. 1000/25V-25p.
1000/40V-35p. 4700V/25V-70p.

Subminiature bead Tantulum electrolytics.
0.1, 0.22, 0.47, 1.0 @ 35V, 4.7 @ 6.3V - 14p.
2.2/35V, 4.7/25V-15p. 10/25V, 15/16V-20p.
22/16V, 33/10V, 47/6V, 68/3V & 100/3V-32p.
15/25V, 22/25V, 47/10V-35p. 47/16V-80p.

Subminiature Ceramic Caps. E12 Series 100V.
2% 10 pf. to 47 pf.-3p. 56 pf. to 330 pf.-4p.
10% 390 pf. to 4700 pf.-4p.

Vertical Mounting Ceramic Plate Caps. 50V.
E12 22 pf. to 1000 pf. E6 1500 pf. to 47000 pf.-2p.

Polystyrene E12 Series 63V. Horizontal Mntg.
10 pf. to 820 pf.-3p. 1000 pf. to 10,000 pf.-4p.

Miniature Polyester 250V Vert. Mtg. E6 Series.
0.1 to 0.68-4p. .1-5p. .15, .22-6p. .33, .47-10p.
.68 - 12p. 1.0 - 15p. 1.5 - 22p. 2.2 - 24p.

Mylar (Polyester) Film 100V. Vertical Mounting.
0.01, 0.022, 0.047-3p. 0.1, 0.22-4p. 0.4, 0.5, 0.1-5p.

High Stability Miniature Film Resistors 5%.
1/4W E24 Series 0.51R - 10MΩ - 1p.
1/4W E12 Series 1R0 to 10MΩ - 1 1/2p.
1/4W E12 Series 10R to 10MΩ - 5p.

1/4W metal film E12 Series 10R-1MΩ 5% - 2p. 1%-E24 - 3p.
1N4148-2p. 1N4002-4p. 1N4008-6p. 1N4007-7p.
BC107/8/9-12p. BC147/8/9, BC157/8/9, BF195 & 7-10p.

8 Pin i.c.'s 741 Op. amp.-18p. 555 Timer-24p.
Dil Holders 8 pin-9p. 14 pin-12p. 16 pin-14p.

LED's. 3 & 5mm. Red-10p. Green & Yellow-14p.
Grommets for 3mm-1 1/2p. Grommets for 5mm-2p.

20mm. Q.B. Fuses 15, 25, 5, 1, 2, 3 & 5A-5p.
20mm. Anti Surge 100mA to 50A-8p.

20mm. Fuseholders P.C. or Chassis Mtg.-8p.
Battery Snaps (pairs) PP3-6p. PP9-12p.

400mW Zener diodes E24 series 2V7 to 33V-8p.
Prices VAT inclusive Post 20p. (Free over £5.00).

THE C.R. SUPPLY CO.

127, Chesterfield Rd., Sheffield S8 0RN.

SERVICES

INVENTORS

Think of something new?
Write it down! -

American industry offers potential royalties for your innovations and new products. We offer free confidential disclosure registration and initial consultation in London regarding your idea's potential value. Write without delay for your free information package.

American Inventors Corporation
82, Broad Street, Dept PT
Westfield, Massachusetts 01086
United States of America.

A fee based marketing company.

HOME SECURITY

CENTURION ALARMS

Manufacturers of Professional Alarm Equipment for DIY & the TRADE. Send now for our New Top-page Brochure. Full of Information & the Lowest prices.

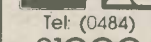
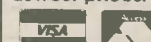

Tel: (0484) 21000 or 35527 24 hr.

CENTURION Dept PE
93 Wakefield Road,
Huddersfield.
HD5 9AB
W. Yorks.

© "CENTURION" is a Registered trademark of Centurion Alarms

WHO CAN PUT A PRICE ON A PEACE OF MIND
PROFESSIONAL EQUIPMENT AT LOW! LOW! PRICES.
HOME SECURITY IS NOW AVAILABLE AT TRADE PRICES
ADVANCED SECURITY PRODUCTS LTD
2 Ealing Road, Aintree,
Liverpool L9 0HU, Merseyside.
Tel: 051-525 3440
FREE CATALOGUE PHONE OR S.A.E.

ORDER FORM PLEASE WRITE IN BLOCK CAPITALS

Please insert the advertisement below in the next available issue of Practical Electronics for

insertions. I enclose Cheque/P.O. for £.....

(Cheques and Postal Orders should be crossed Lloyds Bank Ltd. and made payable to Practical Electronics)

NAME

ADDRESS

PRACTICAL ELECTRONICS

Classified Advertisement Dept., Room 2612,
King's Reach Tower, Stamford Street,
London SE1 9LS Telephone 01-261 5846

Rate:
36p per word, minimum 12 words. Box No. 60p extra.

HOME SECURITY CONT.

MRP ALARMS. Professional, Domestic and Commercial security alarm equipment at low trade prices. Send S.A.E. for information and prices to: 146 Almsford Drive, Harrogate. (OR PHONE) 0423-870295.

SECURITY Alarm Systems

FREE COMPREHENSIVE CATALOGUE!

- LOWEST DISCOUNT PRICES
- HIGHEST QUALITY EQUIPMENT
- FREE DIY DESIGN GUIDE
- FULLY ILLUSTRATED
- MICROCHIP CIRCUITRY
- QUICK DESPATCH SERVICE
- FULL INSTRUCTIONS

SEND SAE OR PHONE

C-TEC SECURITY, Dept PE.

Unit 1, Stephenson Way Ind. Estate, Goose Green, Wigan WN3 6PH. Telephone (0942) 42444



BOOKS AND PUBLICATIONS

FULL SIZE, top quality service sheets £2.50 + l.s.a.e. CTV/ Music Centres £3.50 + l.s.a.e. Repair data almost any named TV-Video £10.50 inc. circuits. L.s.a.e. brings any quote free magazine/price lists. TISPE, 76 Churches, Larkhall, Lanarkshire. 0698 883334.

BOOKS WANTED FOR CASH

Top prices paid for your unwanted electronics and computer books.

We also have a wide selection of new and used books and magazines in stock.

For list of currently available titles and details of our guaranteed buy back plan SAE please to:

JAMES ELECTRONICS (DEPT. P.E.)

P.O. Box 2, Rothwell, Leeds LS26 0UY

COURSES

FULL-TIME TRAINING COURSES

2 YEAR

BTEC National Diploma (OND)
ELECTRONIC &
COMMUNICATIONS ENGINEERING
(Television & Computing)

15 MONTHS

BTEC National Certificate (ONC)
ELECTRONIC EQUIPMENT SERVICING
(Television & Video)

15 MONTHS

BTEC National Certificate (ONC)
COMPUTING TECHNOLOGY

9 MONTHS

BTEC Higher National Certificate (HNC)
COMPUTING TECHNOLOGY
& ROBOTICS

HIGH PERCENTAGE OF COLLEGE BASED PRACTICAL WORK

SHORT COURSES WITH PREVIOUS KNOWLEDGE

NO EXTRA CHARGES FOR OVERSEAS STUDENTS

Prospectus from:

LONDON ELECTRONICS COLLEGE

Dept: AA, 20 Penywern Road, London SW5 9SU. Tel: 01-373 8721.

EDUCATIONAL

Are you interested in a career in ELECTRONIC ENGINEERING?

A 48-week full-time course leading to the BTEC NATIONAL CERTIFICATE IN ELECTRONIC ENGINEERING is available at

THE EAST YORKSHIRE COLLEGE OF FURTHER EDUCATION

West Street Manorfield Road
Bridlington Driffield
Tel. 672676 Tel: 42401

Contact the College for further details
Humberstone County Council

MISCELLANEOUS

CLEARING LABORATORY. scopes, generators, P.S.U.'s, bridges, analysers, meters, recorders etc. Tel. 0403-76236.

LASERS. Low, high power systems. Scan heads, controls etc. Lites 50p. LASERTRONICS, 21 Grosvenor Road, Scarborough.

BURGLAR ALARM EQUIPMENT. Ring Bradford (0274) 308920 for our catalogue or call at our large showroom, opposite Odsal Stadium.

SUPERB INSTRUMENT CASES by Bazelli, manufactured from PVC. Faced steel. Vast range, competitive prices start at a low £1.50. Punching facilities at very competitive prices. BAZELLI, (Dept. 23), St. Wilfreds, Foundry Lane, Halton, Lancaster LA2 6LT.

RUGBY TIME?

MSF CLOCK, self setting Date, Hours, Minutes, Seconds, never gains or loses, decodes 60KHz atomic time signals, built-in antenna fun-to-build kit £79.70 includes ALL parts, case, by-return postage etc.

CAMBRIDGE KITS

45 (FS) Old School Lane, Milton, Cambs.

CABINET FITTINGS

Fretcloths, Coverings, Handles, Castors, Flight Case Locks & Parts, Jacks, XLRs, Bulgins, Reverb Trays, P & N mic Stands, ASS Glassfibre Horns, CELESTION POWER Speakers.

ADAM HALL SUPPLIES LTD.

Send

30p cheque/
P.O. for illustrated
catalogue: Adam Hall (PE Supplies),
Unit G, Carlton Court, Grainger Road,
Southend-on-Sea.

THE SCIENTIFIC WIRE COMPANY
811 Forest Road, London E17. Telephone 01-531 1568

ENAMELLED COPPER WIRE

SWG	1 lb	8 oz	4 oz	2 oz
8 to 34	3.63	2.09	1.10	0.88
35 to 39	3.82	2.31	1.27	0.93
40 to 43	6.00	3.20	2.25	1.61
44 to 47	8.67	5.80	3.49	2.75
48	15.96	9.58	6.38	3.69

SILVER PLATED COPPER WIRE

14 to 30	9.09	5.20	2.93	1.97
----------	------	------	------	------

TINNED COPPER WIRE

14 to 30	3.97	2.41	1.39	0.94
----------	------	------	------	------

Prices include P&P VAT. Orders under £2 add 20p. SAE for list of copper and resistance wire. Dealer enquiries welcome.

★ BAKER ★

GROUP P.A. DISCO AMPLIFIERS post £2

150 watt Output, 4 input Mixer pre-amp. Illustrated	£99
150 watt Output, Slave 500 mv. Input 3 Speaker Outputs	£80
150+150 watt Stereo, 300 watt Mono Slave 500 mv. Inputs	£125
150 watt P.A. Vocal, 8 inputs. High/Low Mixer Echo Socket	£129
100 watt Valve Model, 4 inputs, 5 Outputs. Chassis only	£99
60 watt Mobile 240 AC and 12V DC. 4 16 ohm x 100 line	£89
Reverb Unit for Microphone or Musical Instruments	£35 PP £1.
Electronic Echo Machine for mic/etc	£85 PP £1. Deluxe £95.

BAKER LOUDSPEAKERS Post £2 each

Type	Model	Size	Watts	Ohms	Price
P.A./Disco/Group	DG50/10	10	50	8/16	£18.00
Midrange	Mid 100/10	10	100	8	£25.00
Hi-Fi	Major	12in	30	4/8/16	£16.00
Hi-Fi	Superb	12in	30	8	£26.00
P.A./Disco/Group	DG45	12in	45	4/8/16	£16.00
Hi-Fi	Woofier	12in	80	8	£25.00
Hi-Fi	Auditorium	15in	60	8/16	£37.00
P.A./Disco/Group	DG75	12in	75	4/8/16	£20.00
P.A./Disco/Group	DG100	12in	100	8/16	£26.00
P.A./Disco/Group	DG100/15	15in	100	8/16	£35.00

DISCO CONSOLE Twin Decks, mixer pre amp £145. Carr £10. Ditto Powered 120 watt £199; or Complete Disco £300. 120 watt £300; 150 watt £360; 300 watt £410. Carr £30.

DELUXE STEREO DISCO MIXER/EQUALISER plus L.E.D. V.U. displays 5 band graphic equaliser, left/right fader, switchable inputs for phone/line, mike/line

Headphone Monitor, Mix Control Switch £124 PP £2 As above but 3 Deck inputs, 4 Line/Aux inputs, 2 Mic. inputs, 2 Headphone Monitors, Stereo Graphic + LED Display £145.

P.A. CABINETS (empty) Single 12 £32; Double 12 £38. carr £10. WITH SPEAKERS 75W £54; 90W £73; 150W £82; 200W £90. HORNBOXES 200 Watt £32; 300 Watt £38. Post £4.

WATERPROOF HORNS 8 ohms. 25 watt £22. 30 watt £25. 40 watt £33. 20W plus 100 volt line £38. Post £2.

MOTOROLA PIEZO ELECTRONIC HORN TWEEETER 3 1/2in. square £6 100 watts. No crossover required. 4-8-16 ohm, 7/8x3/8in. £10

CROSSOVERS. TWO-WAY 3000 c/s 40 watt £45. 60 watt £5. 100 watt £5. 3 way 590 cps/3000 cps. 60 watt £6.50. 80 watt £7. 100 watt £10.

LOUDSPEAKER BARGAINS. Please enquire, many others in stock. 4 ohm, 5in. 7x4in. £2.50. 8/2in. 8x5in. £3. 6in. £3.50. 2in. 2 1/2in. £1.50. 8 ohm, 2 1/2in. 3in. £2. 5x3in. 6x4in. 7x4in. 5in. £2.50. 6 1/2in. 8 x 5in. £3. 8in. £4.50. 10in. £5. 12in. £6. 3in. 2 1/2in. 5in. 8in. 10in. 12in. £1.50. 15 ohm, 2 1/2in. 3 1/2in. 5x3in. 6x4in. £2.50. 8/2in. 10W £5. 8in. £4. 10in. £7. 25 ohm. 3in. £2. 5x3in. 6x4in. 7x4in. £2.50. 12in. 0hm, 3 1/2in. dia. £1.

Make	Model	Size	Watts	Ohms	Price Post
AUDAX	WOOFER	5 1/2in. 25	8		£10.50 £1
GOODMANS	HIFAX	7 1/2x4 1/4in	100	8	£34 £2
GOODMANS	HB WOOFER	8in.	60	8	£13.50 £1
WHARFEDALE	WOOFER	8in.	30	8	£9.50 £2
CELESTION	DISCO/Group	10in.	50	8/16	£21 £2
SEAS	WOOFER	10in.	50	8	£19.50 £2
GOODMANS	HPD/Group	12in.	120	8/15	£35.00 £2
GOODMANS	HPD/DISCO	12in.	120	8/15	£33.00 £2
H+H	DISCO/Group	15in.	100	4/8/16	£44 £4
GOODMANS	HP/BASS	15in.	250	8	£74 £4
GOODMANS	HPD/BASS	18in.	230	8	£87 £4

METAL GRILLES 8in. £3.00, 10in. £3.50, 12in. £4.50, 15in. £5.50, 18in. £7.50. Loudspeaker Covering Vynal etc. Samples. S.A.E.

DISCO SOUND / LIGHT CONTROLLER

Ready Built Deluxe 4 Channel 4,000 watt sound chaser + speed + programme controls £69. Mk2 16 programmes, £89. PP £2. DISCO "PARTY LITE". Sound Flashing, Light Show, 4 lamps, self contained unit 240v mains. No other connections required £34.95. PP £2.

MAINS TRANSFORMERS	Price Post
250-0-250V 80mA. 6.3V 3.5A. 6.3V 1A.	£7.00 £2
350-0-350V 250mA. 6.3V 6A CT £12.00 Shrouded	£14.00 £2
220V 25mA. 6V 1 Amp. £3.00 220V 45mA. 6V 2 Amp	£4.00 £1
250V 60mA. 6.3V 2A.	£5.00 £1

Low voltage tapped outputs available
1 amp 6, 8, 10, 12, 16, 18, 20, 24, 30, 36, 40, 48, 60. £8.00 £2
ditto 2 amp £10.50 3 amp £12.50 5 amp £16.00 £2
31-26-0-26-33 volt 6 amp £14.00 £2

LOW VOLTAGE MAINS TRANSFORMERS £5.50 each post paid
9V, 3A; 12V, 3A; 16V, 2A; 20V, 1A; 30V, 1 1/2A; 30V, 5A + 17-0-17V, 2A; 35V, 2A; 20-0-20V, 1A; 12-12V, 2A; 20-0-20V, 1A; 50V, 2A.

£8.50 post 50p MINI-MULTI TESTER
Pocket size instrument. o.p.v. DC volts 5, 25, 250, 500. AC volts 10, 50, 500, 1000. DC 0-250uA; 0-250mA. Resistance 0 to 600k. De Luxe Range Doubler Meter. 50000 op.v. 7 x 5 x 2in. Resistance 20 meg in 5 ranges. Current 50uA to 10A. Volts 0.25/1000V DC, 10v/1000v AC. £25.00 post £1

PANEL METERS 50uA, 100uA, 500uA, 1mA, 5mA, 100mA, 500mA, 1 amp, 2 amp, 5 amp, 25 volt, VU 2 1/4x2x1 1/4in. £5.50 post 50p

PROJECT CASES. Black Vinyl Covered Top, All Base
4 x 2 1/2 x 2 1/4in. £2.50; 6 x 4 x 1 1/2in. £3.60; 8 x 5 x 2in. £4.00; 11 x 6 x 3in. £5.50; 1 1/4 x 6 x 5in. £9.00; 1 1/2 x 8 x 4in. £12.00.

ALUMINIUM PANELS 18 s.w.g. 12 x 12in. £1.80; 14 x 9in. £1.75; 6 x 4in. 55p; 12 x 8in. £1.30; 10 x 7in. 96p; 8 x 6in. 90p; 14 x 3in. 72p; 12 x 5in. 90p; 16 x 10in. £2.10; 16 x 6in. £1.30.

ALUMINIUM BOXES. 4 x 4 x 2 1/4in. £1.60; 7 x 5 x 2 1/2in. £2.90; 3 x 2 x 1in. £1. 4 x 2 1/2 x 2in. £1.20; 4 x 4 x 1 1/2in. £1.50; 6 x 4 x 2in. £1.90; 8 x 4 x 3in. £2.20; 8 x 6 x 3in. £3.00; 10 x 7 x 3in. £3.60. 12 x 5 x 3in. £3.60; 12 x 8 x 3in. £4.30; 10 x 4 1/2 x 3in. £2.90; 4 x 5 1/4 x 2 1/2in. £1.50; 4 x 2 1/4 x 1 1/2in. £1.20.

HIGH VOLTAGE ELECTROLYTICS 20+20/350V 75p
16/450V 50p 220/400V £2
32+32/500V £2
20/500V 75p 8+8/500V £1
32+32/350V 50p
32/350V 45p 8+16/450V 75p 32+32+32/450V £1.50
32/500V 95p 16+16/350V 75p 16+32+32/500V £2

SINGLE PLAY RECORD DECKS. Post £2
Make Drive Model Cartridge Price
BSR Belt P232 Ceramic £28
BSR Belt P232 Magnetic £28
BSR Rim P207 Ceramic £20
AUTOCHANGER BSR Ceramic £20
AUTOCHANGER GARRARD Ceramic £24

DECCA TALK VEENEERED PLINTH space for small amplifier Board cut for BSR or Garrard 18 3/4in. x 14 1/4in. x 4in. £5. Post £1

★ ★ ★ "STOP PRESS" ★ ★ ★
H & H 1000 Watt stereo/mono Amplifiers S500D Reconditioned, guaranteed. £275, carriage £5.

RADIO COMPONENT SPECIALISTS
Dept 4, 337, WHITEHORSE ROAD, CROYDON
SURREY U.K. Tel: 01-694 1665

Post 85p Minimum. Callers Welcome. Same day despatch. Closed Wed. Lists 34p

ACCESS VISA

GET YOUR FREE INFORMATION CARDS & SAMPLE COMPONENT PACK!

COMPLETE SOLDERING KIT
(For the Hobbyist/Electronics Engineer)

LIMITED OFFER WHILE STOCKS LAST!

FOR LESS THAN £10!!

Comprises of:-

- Antex Miniature 15W 240v AC Soldering Iron
- Antex Iron Stand c/w Sponge
- Desolder Pump
- 2 mtr Solder
- Desolder Braid
- 13A Plug

ONLY £9.85

Please add 80p, P&P + 15% VAT



Iron Stand c/w Sponge

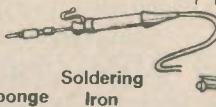

Soldering Iron

Desolder Pump



Call in and see our new counter now open
9.00 - 5.00 Mon-Fri 9.00 - 12.00 Sat
Too far to call? Don't worry, export/mail order is our speciality. Why not write and find out more.



24 hr answerphone for credit card orders
Tel: 0244 536699



SYSTEMS ELECTRONIQUE
(U.K.) LTD.

26 Engineer Park, Sandycroft, Deeside, Clwyd CH5 2QD.
Tel: (0244) 536700.

FREE A4 SIZE PRICECARDS

We supply free cards containing kits' and special offers information plus six basic component-cards. These cover the general ranges required by hobbyists, schools and colleges etc; they are Connectors, Passive components, Opto-electronics, Hardware and Semiconductors. Cards are automatically updated by post. Send now for your free cards and free SAMPLE COMPONENT PACK.

ORIC AND SINCLAIR COMPUTERS



Oric 1 computer 48K £75 (£72) £82. Oric Atmos computer 48K £121 (£108) £118. CCP40 Oric colour printer £124 (£115) £132. Sinclair pocket TV (£113) (£105) £115. Sinclair QL Computer £406 (£385) £410. QL Floppy disc interface £154 (£138) £148. Sinclair Spectrum Plus Computer 48K £131 (£131) £153. Kit to upgrade the Spectrum to Spectrum Plus £30 (£30) £40. Microdrive £51 (£50) £60. RS232 interface 1 £51 (£50) £60. Special offer: Microdrive + Interface 1 + 4 cartridges £102 (£100) £120. Blank microdrive cartridges £2.50 (£3) £4. Spectrum floppy disc interface (See Cumana disc section for suitable disc drives) £102 (£92) £112. Fuller FDS keyboard for Spectrum £52 (£52) £62. Fuller master unit £42 (£42) £52. Interface 2 £20.45 (£20) £24. 32K memory upgrade kit for 16K Spectrum (issue 2 and 3 only) £31 (£28) £30. Spectrum Centronics printer interface £51 (£47) £52. ZX printer has been replaced by the Alphacom 32 £71 (£69) £82. 5 printer rolls (state whether Sinclair or Alphacom) £13 (£16) £21. ZX81 computer £35 (£35) £45. 16K ram packs for ZX81 £28 (£25) £30.

COMMODORE COMPUTERS

Commodore C16 Starter Pack £145 (£142) £162. Commodore Plus/4 £305 (£281) £301. Commodore 64 £222 (£215) £235. Converter to allow most ordinary mono cassette recorders to be used with the Vic 20 and the Commodore 64: £9.78 (£9) £11. Bargain package:- cassette converter + compatible cassette recorder £37 (£38) £44. Commodore cassette recorder £43 (£44) £50. Printer interfaces for Vic 20 and the Commodore 64:- Centronics £45 (£41) £46. RS232 £45 (£41) £46. Disc drive £233 (£209) £234. 1520 printer/plotter £99 (£96) £111. MPS801 Printer £235 (£220) £245.

SWANLEY ELECTRONICS

The Computer Export Specialists
Dept PE, 32 Golds Rd., Swanley, Kent BR8 8EZ, England.

Please allow 7 days for delivery.

Tel: Swanley (0322) 64851. Official orders welcome. UK prices are shown first and include post and VAT. The second price in brackets is for export customers in Europe and includes insured air mail postage. The third price is for export customers outside Europe (including Australia etc) and includes insured airmail postage.

ATARI, ENTERPRISE, MSX AND ACORN COMPUTERS

Atari 800XL computer £135 (£135) £150. Atari data recorder £37 (£37) £47. Atari disc drive £205 (£189) £209. Atari 1020 printer £102 (£99) £115. Enterprise 64 computer £261 (£236) £256. MSX Goldstar computer £203 (£193) £213. Acorn Electron £119 (£119) £139. BBC Model B £404 (£357) £387. BBC Model B with disc interface £480 (£423) £453. Colour monitor £228 (£228) £268. Kenda double density disk interface system £149 (£131) £141. See below for suitable disc drives.

CUMANA DISC DRIVES

To suit disc interfaces of Sinclair QL, Spectrum, BBC B and Videogenic. Single: 40 track single sided £176 (£158) £178. 40 tr double sided £218 (£195) £215. 80tr ss £207 (£186) £206. 80tr ds £234 (£209) £229. Dual:- 40tr ss £299 (£280) £320. 40tr ds £395 (£353) £393. 80tr ss £372 (£334) £374. 80tr ds £437 (£390) £430.

PRINTERS

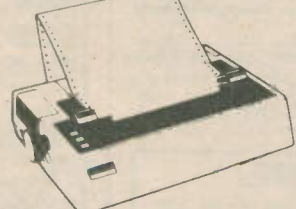

Brother HPS £162 (£146) £170. Shinwa CTI CPA80 £237 (£228) £258. Cannon PW1080A £382 (£344) £374. Epson RX30 £277 (£251) £282. Epson RX80FF £314 (£286) £316. Epson FX80 £339 (£298) £328. Combined matrix printers and electric typewriters: Brother EP22 £163 (£156) £176. Brother EP44 £258 (£235) £260. Interfaces to run the above printers from Vic and the Commodore 64 £45 (£41) £46. UK101, SUPERBOARD AND VIDEOGENIE We still support these Computers. Write for our list.

BAKER'S DOZEN PACKS

SUPER BARGAIN PACKS £1 EACH
ORDER 12 AND GET ONE EXTRA FREE!

ALL GOODS BRAND NEW EXCEPT WHERE STATED

Please add £1 post if order under £20

Pack No.	Qty	Description	Pack No.	Qty	Description
1	5	13 amp ring main junction boxes	35	4	battery operated model motors
2	5	13 amp ring main spur boxes	36	2	air spaced 2 gang tuning condensers
3	25	13 amp fuses for ring mains	37	2	solid dielectric 2 gang tuning condensers
4	5	surface mounting switches	38	10	compression trimmers
5	3	flush switches intermediate type	39	1	Long & medium wave tuner kit
6	5	in flex line switches	40	4	x 465 KC IF transformers
7	4	in flex line switches with neons	41	8	rocker switches 10a mains SPST
8	2	80 watts brass cased elements	42	6	rocker switches 10a mains SPST
9	2	mains transformers with 5v 1a secondaries	43	5	rocker switches 10a SPST
10	2	mains transformers with 12v 1/2a secondaries	44	1	24 hour time switch mains operated
11	1	extension speaker cabinet for 6 1/2" speaker	45	1	6 hour clockwork time switch
12	5	octal bases for relays or valves	46	2	2 level switches 4 pole changeover up and ditto down
13	12	glass reed switches	47	2	5v operated reed switch relays
14	4	DCP 70 photo transistors	48	2	neon valves - make good night lights
15	25	assorted germanium transistors OCA5 etc	49	10	x 12v DC or 24v AC 3C 0 relays
16	4	tape heads, 2 record, 2 erase	50	2	x 12v DC or 24v AC 3C 0 relays
17	2	ultrasonic transmitters and 2 data receivers	51	1	x 12v DC very sensitive relay
18	2	15000 micro computer capacitors	52	1	x 12v DC relay
19	2	l.d.r. similar ORP 12	53	2	mains operated relays 3 x 8a changeovers (second hand)
20	5	diff micro switches	54	10	rows of 32 gold plated IC sockets (total 320 sockets)
21	2	mains interference suppressors	55	1	miniature Uniselerator with circuit for electric jigsaw puzzle
22	2	25 watt crossover units	56	5	dolls house switches
23	1	40 watt 3 way crossover unit	57	2	telephone handsets
24	250	screws and self tappers	58	2	flat solenoids - to make current transformer etc
25	1	each water switches - 6p 2 way; 4p 3 way; 2p 6 way; 1p 12 way	59	2	ferrite rods 4" x 5" - 16" dia
26	2	tape deck counters	60	5	ferrite slab aenals LW & MW
27	1	6 digit counter 12v	61	4	200 ohm ear pieces
28	1	6 digit counter mains voltage	62	1	Mullard Thyristor trigger module
29	1	BOAC in flight stereo unit (s.h)	63	10	assorted knobs - 1/4, spindles
30	2	NICAD battery chargers	64	5	diff thermostats
31	1	key switch with key			
32	2	humidity switches			
33	2	aerosol cans of ICI Dry Lubricant			
34	96	x 1 metre length colour-coded wires			

Most items available in quantity at good discounts.

ACCESS & BARCLAY CARDS WELCOME ☎ 0444 454563

J.BULL (Electrical) Ltd.

(Dept. PE), 34-36 AMERICA LANE,
HAYWARDS HEATH, SUSSEX RH16 3QU.

Established
30 YEARS

CRICKLEWOOD ELECTRONICS LTD

It's no secret!

... that there is a real difference at Cricklewood Electronics. That's why you should never be without the FREE CRICKLEWOOD ELECTRONICS COMPONENTS CATALOGUE, for sheer variety, competitive prices and service from the U.K.'s number one 100% component shop. No gimmicks, no gadgets or computers, just components, millions of them, all easily available by mail order, calling or credit card telephone orders. Just pick up the phone (or a pen) to get your FREE copy now (no SAE required). You have nothing to lose.

CRICKLEWOOD ELECTRONICS LTD.
40 Cricklewood Broadway NW2 3ET.
01-450 0995/01-452 0161

Telex 914877

ALL MAJOR CREDIT CARDS ACCEPTED

Phone or write today



Published on approximately the 7th of each month by IPC Magazines Limited, Westover House, West Quay Road, Poole, Dorset BH15 1JG. Printed in England by McCorquodale Magazines Ltd., Andover, Hants. sole Agents for Australia and New Zealand - Gordon and Gotch (Asia) Ltd.; South Africa - Central News Agency Ltd. Subscriptions INLAND £13 and OVERSEAS £15 payable to IPC Magazines Ltd., "Practical Electronics" Subscription Department, Room 2816, King's Reach Tower, Stamford Street, London SE1 9LS. PRACTICAL ELECTRONICS is sold subject to the following conditions, namely that it shall not, without the written consent of the Publishers first having been given, be lent, resold, hired out or otherwise disposed of by way of Trade at more than the recommended selling price shown on the cover, and that it shall not be lent, resold, hired out or otherwise disposed of in a mutilated condition or in any unauthorised cover by way of Trade or affixed to or as part of any publication or advertising, literary or pictorial matter whatsoever.

INDEX TO ADVERTISERS

AC/DC Electronics	61	Hall, Adam, Supplies	63
A.D.E.	62	Humberside County Council	63
Alcon Instruments	4	ICS Intertext	4
American Inventive Corp.	62	James Electronics	63
Antex	31	London Electronics College	63
Armon Electronics	18	Maplin Supplies	O.B.C.
Audio Electronics	52	Marco Trading	51
Bensham Recordings	18	Phonosonic	17
Bi-Pak	43	Powertran	I.F.C., I.B.C.
B.N.R.E.S.	18	Ralf Electronics	57
Bull J.	64	R.C.S.	63
Cambridge Kits	52, 53	Riscomp	17
Centurion Alarms	62	Scientific Wire Co.	63
Clef Products	18	Skybridge	52
Computronics	63	Swanley Electronics	64
Cricklewood Electronics	64	System Electronique	64
Croton Electronics	52	Tandy	6
Cybernetic Application	57	T.K. Electronics	5
Electrovalue	61	Watford Electronics	2 & 3
G.C.H.Q.	57	Wersi Organs	51
Grandata	4		
Greenwald	61		

MCS/1

DIGITAL SAMPLER & DELAY LINE

Just one of our customers for the MCS/1
- Midge Ure of Ultravox.
Get the professional sound of a
Powertran MCS/1 into your act.

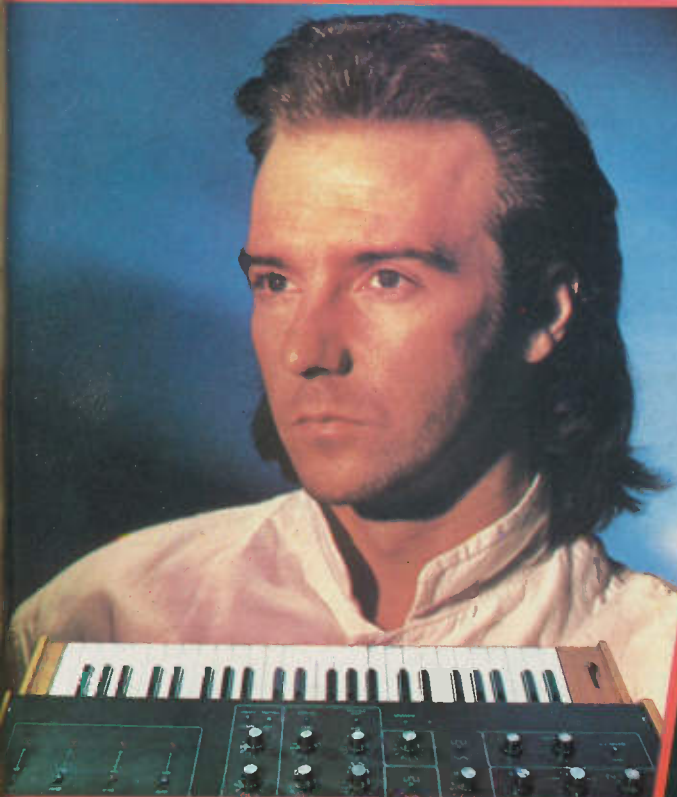

Once again, Powertran and E&MM combine to bring you versatility and top quality from a product out of the realms of fantasy and within the reach of the active musician.

The MCS-1 will take any sound, store it and play it back from a keyboard (either MIDI or v/octave). Pitch bend or vibrato can be added and infinite sustain is possible thanks to a sophisticated looping system.

All the usual delay line features (Vibrato, Phasing, Flanging, ADT, Echo) are available with delays of up to 32 secs. A special interface enables sampled sounds to be stored digitally on a floppy disc via a BBC microcomputer.



The MCS-1 gives you many of the effects created by top professional units such as the Fairlight or Emulator. But the MCS-1 doesn't come with a 5-figure price tag. And, if you're prepared to invest your time,

it's almost cheap!

MCS-1 complete only £849 + VAT

Save even more with the MCS-1 kit:

only £599 + VAT

Demonstration Tape £2.50 + VAT

Powertran kits are complete down to the last nut and bolt, with easy-to-follow assembly instructions.

POWERTRAN

CYBERNETICS LIMITED

POWERTRAN CYBERNETICS LIMITED

Portway Industrial Estate, Andover, Hants SP10 3PE, England

Telephone: Andover (0264) 64455

Access/Visa cardholders - save time - order by phone.



Specification

Memory Size: Variable from 8 bytes to 64K bytes.
Storage time at 32 KHz sampling rate: 2 seconds.
Storage time at 8 KHz sampling rate: 8 seconds.
Longest replay time (for special effects): 32 seconds.
Converters. ADC & DAC: 8-bit companding.
Dynamic range: 72 dB.
Audio Bandwidth: Variable from 12 KHz to 300 Hz.
Internal 4 pole tracking filters for anti-aliasing and recovery.
Programmable wide range sinewave sweep generator.
MIDI control range: 5 octaves.
+1 V/octave control range: 2 octave with optional transpose of a further 5 octaves.



From a gentle purr to a mighty roar, the tightly controlled power of the beast is yours to command!

All new in the 1985 Catalogue



PROFESSIONAL QUALITY HIGH POWER LOUDSPEAKERS

A new range of superb quality loudspeakers.

- ★ Virtually indestructible high temperature voice-coil reinforced with glass-fibre
- ★ 100% heat overload tolerance
- ★ Advanced technology magnet system
- ★ Rigid cast alloy chassis
- ★ Linen or Plastiflex elastomer surrounds
- ★ 5-year guarantee (in addition to statutory rights)



Available in 5, 8, 10, 12, 15 and 18 inch models with 8Ω and some 16Ω impedances and with input powers ranging from 50W to 300W e.g.

- 5in. 50W 95dB 8Ω: XG39N / 16Ω: XG40T £17.95§
- 8in. 100W 98dB 8Ω: XG43W £29.95§
- 10in. 100W 100dB 8Ω: XG46A £29.95§
- 12in. 100W 101dB 8Ω: XG49D £29.95§
- 12in. Twin Cone 100W 100dB 8Ω: XG50E / 16Ω: XG51F £31.95§

Note - the output power doubles for each 3dB increase (ref 1W @ 1m).

PRECISION GOLD MULTIMETERS

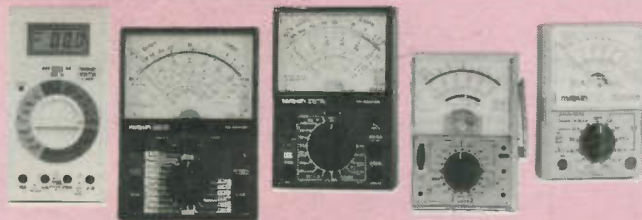

A new range of very high quality multimeters offering truly amazing quality at the price.

- Pocket Multimeter, 16 ranges, 2000Ω/V DC/AC £6.95§ (YJ06G)
- M-102BZ with Continuity buzzer, battery tester and 10A DC range, 23 ranges, 20,000Ω/V DC £14.95§ (YJ07H)
- M-2020S with Transistor, Diode & LED tester and 10A DC range, 27 ranges 20,000Ω/V DC £19.95§ (YJ08J)
- M-5050E Electronic Multimeter with very high impedance, FET input, 53 ranges including peak-to-peak AC, centre-zero and 12A AC/DC ranges £34.95§ (YJ09K)
- M-5010 Digital Multimeter with 31 ranges including 20Ω and 20μA DC/AC FSD ranges, continuity buzzer, diode test, and gold-plated PCB for long-term reliability and consistent high accuracy (0.25% +1 digit DCV) £42.50§ (YJ10L)

N.B. All our prices include VAT and Carriage. A 50p handling charge must be added if your total order is less than £5 on mail order (except catalogue).

MAPLIN ELECTRONIC SUPPLIES LTD.

Mail Order: P.O. Box 3, Rayleigh, Essex SS6 8LR. Tel: Southend (0702) 552911 SHOPS

- BIRMINGHAM Lynton Square, Perry Barr, Tel: 021-356 7292.
 - LONDON 159-161 King Street, Hammersmith, W6. Tel: 01-748 0926.
 - MANCHESTER 8 Oxford Road, Tel: 061-236 0281.
 - SOUTHAMPTON 46-48 Bevois Valley Road, Tel: 0703 25831.
 - SOUTHEAST 282-284 London Rd, Westcliff-on-Sea, Essex. Tel: 0702-554000
- Shops closed all day Monday.

§ Indicates that a lower price is available in our shops.

Our huge range of top quality electronic components at very competitive prices are all detailed in our catalogue, and with well over 600 new lines in our 1985 edition and many design improvements, it's well worth getting a copy. Here are just a few examples from the catalogue. (The items below are NOT kits).

- ★ Most phono and jack plugs now with integral strain relief sleeve - gold-plated types also available from 14p (gold from 70p)
- ★ Stereo Disco Mixer with cross-fade, talk-over, cue monitoring, aux input, slide controls. Only £58.95 (AF99H)

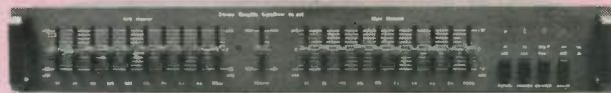

★ 10-Channel Stereo Graphic Equalisers - 3 models - basic; with peak level meter; and with spectrum analyser - from £77.95



★ Digital Delay Line permits Slap-back, Doubling, Flanging, Chorus and Echo. 11 controls. Only £195.00 (AF98G)

★ Video Enhancer improves picture quality when recording from one VTR to another, and with TV's with monitor input. Only 28.95 (XG59P)

★ Detailed descriptions of the exciting new 74HC range of IC's which combine the advantages of CMOS and TTL. From 46p

★ Keyboards: sloping keys, two-tone grey, mounted in steel frame, very smart cases (extra) available. 61 keys, only £33.95 (YJ12N) 79 keys, only £37.95 (YJ13P)

★ 1% Resistors now 50ppm/°C, 0.4W, only 2p each!

★ Auto transformers 120/240V 50VA, £10.75§ (YJ56L). 100VA £14.95§ (YJ57M). 150VA £16.95§ (YJ58N). 250VA £21.95§ (YJ59P).

★ Digital Clinical Thermometer. Only £13.95 (FK51F)

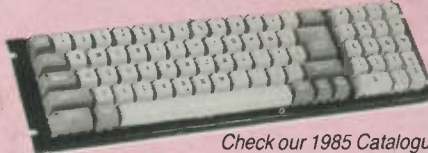

Check our 1985 Catalogue for all our other fascinating new lines.



☎ Phone before 2pm for same day despatch.

1985 CATALOGUE

Pick up a copy now at any branch of W.H. Smith or in one of our shops. The price is still just £1.35, or £1.75 by post from our Rayleigh address (quote CA02C).

Post this coupon now for your copy of the 1985 catalogue. Price £1.35 + 40p post and packing. If you live outside the U.K. send £2.40 or 11 International Reply Coupons. I enclose £1.75.

Name

Address

.....

.....

PE/5/85

All offers subject to availability.

Prices firm until May 11th 1985.