

# Practical Electronics

APRIL 1965

PRICE 2'6

**FREE  
inside**

**"PRINTED  
WIRING"  
BOARD**  
with details of  
6 Interesting  
Projects to  
build.



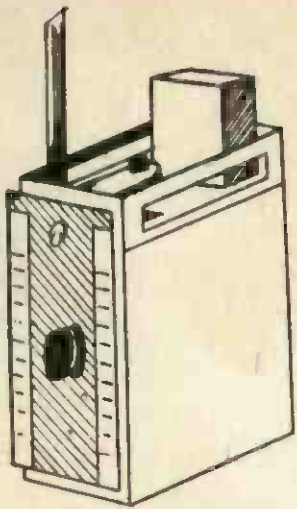

### VEHICLE RADIO-TELEPHONE

Originally used by the Armed Forces for field communication. This compact little unit can be powered by a car battery, and two 60 v. or 90 v. H.T. batteries. Communication is possible up to a distance of 3 miles in favourable terrain, and on testing the receiver we were able to receive many Continental and Maritime stations. Battery drain is less than 1/2 of an amp. Output stage de-commissioned to conform with regulations. Full wiring instructions provided.

Price 5 Gns. each, carriage free. 2 for £10, carriage free.

### 19 SET TRANS/REC MAINS POWER PACK

Operate your 19 set receiver straight off the mains. Ready built power unit complete with modification and fitting instructions. Price 59/6 P. & P. 3/6. Suitable head-phone for same, price 15/- P. & P. 2/8. Please state Mk. 11 or 111.

### POWER PACK

Housed in compact metal case. 200/250 v. A.C. mains. Output 250 v. 60 mA fully smoothed. 6.3 at 2 amps. Can be used for powering almost any pre-amp or radio tuner. Price 39/8. P. & P. 2/8.

19 Set Instruction Handbook  
3/6 each, p/p 6d.

1155 Instruction Handbook  
3/6 each, p/p 6d.

H.R.O. Instruction Handbook  
3/6 each, p/p 6d.

Frequency Meter, BC 221 Instruction Handbook  
3/6 each, p/p 6d.

46 Walkie Talkie Set Instruction Handbook  
3/6 each, p/p 6d.

38 Set A.F.V. Instruction Handbook  
3/6 each, p/p 6d.

R.F. Unit 24 Circuit Diagram and Details  
Price 1/6, p/p 3d.

R.F. Unit 25 Circuit Diagram and Details  
Price 1/6, p/p 3d.

R.F. Unit 26 Circuit Diagram and Details  
Price 1/6, p/p 3d.

Receiver R1355 Circuit Diagram and Details  
Price 1/6, p/p 3d.

Receiver R1224A Circuit Diagram and Details  
Price 1/6, p/p 3d.

R116/A Circuit Diagram and Details  
Price 1/9, p/p 3d.

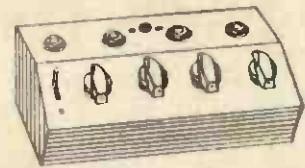

### SONA SOUNDMASTER TRANSISTORISED MIXER

A compact, ultra modern 4 channel fully transistorised microphone mixer, which permits the mixing of up to 4 instruments, i.e. Mic., Tape, Gram, Tuner, etc. Self contained and operating from a standard 9 v. battery. Handsomely finished case. Ideal for valve or transistor amplifiers. Inputs and outputs take standard plugs. Price 47/6. P. & P. 2/8

### HIGH QUALITY PAXOLIN PANELS

Size 8 1/2 in. x 10 1/2 in. x 1/10th in. Price 1/3 each. P. & P. 7d. Six for 7/6 post free. 12 for 15/- post free.

### TANK AERIALS

Fully interlocking copper sections one foot in length. Will make ideal dipoles, car or scooter aerials. Price, six sections, complete with canvas carrying case, 3/6. P. & P. 1/6. Additional sections 6d. each. Please include sufficient postage.

## THE *Goldemair* "THIRTY" HI-FI AMPLIFIER

A high quality 30-watt amplifier developed for use in large halls and clubs, etc. Ideal for bass, lead or rhythm guitars, schools, dance halls, theatres and public address. Suitable for any type of mike or pick-up. Valve line-up: two E186; one ECC83; one GZ34; two E134. Four separate inputs are provided with two volume controls. Bass and Treble controls are incorporated. Amplifier operates on standard 50 c/s. mains. 3 ohm and 15 ohm speakers may be used. Perforated cover with carrying handles can be provided if required.

go *Goldemair*

Customers are invited to see and hear this amplifier at our shop premises in Lambert's Arcade. Send S.A.E. for illustrated leaflet. Or deposit of £1/16/- and twelve monthly payments of £1/9/2. Total H.P.P. £19.6.0. Carriage 15/- to be sent with deposit.

16 GNS



TWICE THE QUALITY — HALF THE PRICE

### CRYSTAL SET

A wonderful educational set for all children. Provides hours of amusement while following the easy step by step instructions. It is powered entirely by wireless waves, eliminating the expense of batteries. No soldering required. Receives all main stations. Price 25/- P. & P. 2/6.



### TWO-WAY SOUND POWERED TELEPHONE

As used by the Armed Forces. These sound powered earpieces will work up to a distance of 1 mile without the use of batteries. Beautifully made, ideal for use in the house, office or garden. Complete with connecting cable 17/6. P. & P. 2/8.

### LEAD ACID ACCUMULATORS (Unspillable)

2 volts 16 A.H. Brand new. Size 4 x 7 x 2 in. 4/11 each. 3 for 12/6. P. & P. 3/- per cell.



### IMPORTANT BOOKS

No. 148 Practical Transistor Receivers, Book 1. Price 5/-.  
No. 170 Transistor Audio Amplifier Manual. Price 6/-.  
No. 181 22 Tested Circuits, using M.A.T.s. Price 5/-.  
No. 184 Tested Transistor Circuits Handbook, using professional printed circuit modules. Price 2/8.  
No. 185 Tested Short Wave Receiver Circuits, using M.A.T.s. Price 5/-.  
No. 186 Tested Superhet Circuits for Short Wave and Communication Receivers, using M.A.T.s. Price 6/-.  
Resistor Colour Code Indicator. Indicates the value of a resistor at a glance. Price 1/6. P. & P. 3d.  
Please deduct 1/6 on any three books purchased together.

### HEAVY DUTY LOUDSPEAKERS

in Robust Rexine Covered Cabinets.

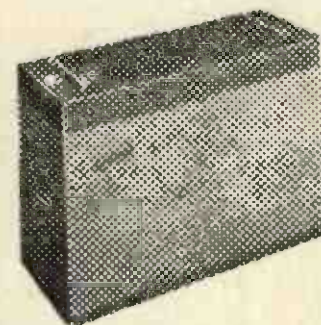

(a) Suitable for bass and lead guitars. Incorporating two 12" high flux 25 watt 15ohm loudspeakers, providing excellent frequency response. Cabinet size approx. 28" x 20" x 10". Rating 50 watts. Fitted with carrying handles. Price 27 gns. of H.P. terms available. Deposit £2-17-0 and 12 monthly payments of £2.6.9. Total H.P.P. £34.18.0. Carriage 15/- to be sent with order.

### AMERICAN V.H.F. SIGNAL GENERATOR TYPE 1-130-A

A very well made instrument with a built-in crystal master oscillator. Exceptionally fine slow motion tuning, with easily read scale. Stepped output and adjustable amplitude. Ideal for two metres and V.H.F. calibration. Price 55/- P. & P. 7/6d.

### TYPE 19 SHORT WAVE RECEIVING SET

Works straight off the mains. An excellent short wave receiver, requires only phones for immediate operation. Price £5/19/8. P. & P. 10/- Sutable phones 15/- per pair. P. & P. 2/6. During an evening's testing of this excellent receiver, we obtained clear reception from scores of stations, many of them thousands of miles distant, including ship stations, Government transmission, maritime broadcasts and also the short wave radio Luxembourg broadcasts.

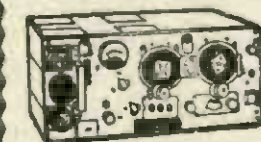

### DOUBLE THROAT MIKES

These can be adapted for use with musical instruments. 5/11 P. & P. 1/-.

POSTAGE RATES APPLY U.K. ONLY. S.A.E. WITH ALL ENQUIRIES  
NEW WALK ROUND STORE OPEN IN LAMBERT'S ARCADE, LOWER BRIGGATE, LEEDS 1, NEXT TO HALFORD'S CYCLE SHOP. OPEN ALL DAY SATURDAY.  
ALL MAIL ORDERS TO OUR BRIGGATE HOUSE ADDRESS.

TERMS  
CASH WITH ORDER  
5/- EXTRA ON C.O.D. ORDERS  
No C.O.D. under 30/-.



SEND 1/- FOR LISTS  
TRADE SUPPLIED  
ORDERS FROM  
ABROAD WELCOMED

SONA ELECTRONIC CO., LTD. (Dept. P.E.6), BRIGGATE HOUSE, 13 ALBION PLACE, LEEDS

# SURBITON PARK RADIO LTD.

ALL ORDERS DESPATCHED SAME DAY

WE PAY POSTAGE AND INSURANCE

SATISFACTION OR MONEY REFUND GUARANTEE ● DEPENDABLE SERVICE

NOTE.— H.P.P. where shown after Cash Price means total Hire Purchase Price.

## LEADING STOCKISTS OF MARTIN RECORDAKITS AND AUDIOKITS

### MARTIN RECORDAKITS

	Dep.	&	Mthly. pmts. of
<b>HALF TRACK</b>			
<b>TAPE AMPLIFIER FOR STUDIO DECK</b> , with ready wired printed circuit, control and input panels, mains and output transformers, knobs, plans, screws etc.; EF86, ECC83, EZ80, EM85 and 2 EL84. 3 watts output. Magic eye, Radio & Mic. inputs, ext. speaker socket, tone and monitor controls. Can be used as an amplifier £11.11.0 (H.P.P. £12.10.0)	47/-	8	25/6
<b>COLLARO STUDIO DECK</b> , very latest model, 3 speeds, 3 motors, 7in. spools £10.19.6 (H.P.P. £12.0.0)	44/-	8	24/6
CASE for above with 8 x 5in. speaker, ..... £5.5.0			
<b>COMPLETE KIT</b> with tape and microphone £29.19.6 (H.P.P. £32.8.0)	120/-	12	44/-
<b>QUARTER TRACK</b>			
<b>TAPE AMPLIFIER FOR STUDIO DECK</b> , as above. £12.12.0 (H.P.P. £13.12.0)	52/-	8	27/6
<b>COLLARO STUDIO DECK</b> , fitted Marriott "X" Series heads ..... £13.19.6 (H.P.P. £15.2.0)	56/-	12	20/6
CASE as above, two tone grey ..... £5.5.0			
<b>COMPLETE KIT</b> with tape and microphone £33.19.6 (H.P.P. £36.14.0)	136/-	12	49/10
<b>SELF-POWERED TAPE PRE-AMPLIFIERS</b>			
<b>HALF TRACK STUDIO deck</b> £8.8.0 (H.P.P. £9.8.0)	34/-	6	25/8
<b>QUARTER TRACK</b> ..... £9.9.0 (H.P.P. £10.9.0)	39/-	6	28/4
<b>TAPE HEADS</b> , Bradmatic Half-Track Record/Replay and Erase on plate ..... £1.19.6			

### MARTIN AUDIOKITS

	Dep.	&	Mthly. pmts. of
<b>MARTIN AUDIOKIT F.M. TUNER UNITS</b> Nos. 15, 16, and 17 to make a high efficiency F.M. Tuner Unit, come to ..... £12.17.6 (H.P.P. £13.17.6)	51/6	12	18/10
We show only the popular units here. Others available including stereo. The following would make up a			
<b>TRANSISTORISED AMPLIFIER 15 ohms MODEL UNIT 1—FIVE INPUT SELECTOR</b> . Size 3½ x 3in. Mag. PU, Crystal PU, Radio, Mic., Tape Head £2.7.6	—	—	—
<b>UNIT 4—PRE-AMPLIFIER AND CONTROL</b> . Size 6½ x 2½in. Volume on/off, bass and treble control. £3.2.6	—	—	—
<b>UNIT 7—MAIN AMPLIFIER</b> , 10 watts 6 transistor, transformerless Push Pull output. Mounted on heat sink. L.S. imp. 15 ohms ..... £6.12.6	—	—	—
<b>UNIT 8—POWER SUPPLY</b> . Gives 18 & 40 volts. Heavy duty transformer, rectifier and smoothing £2.15.0	—	—	—
<b>CONTROL PANEL</b> for Units 1 and 4 ..... 10.6	—	—	—
<b>ALL ABOVE FOUR UNITS WITH PANEL</b> to make 15 ohms assembly £15.8.0 (H.P.P. £16.12.0)	62/-	12	22/6
<b>TRANSISTORISED AMPLIFIER 3 ohms MODEL UNIT 5 MAIN AMPLIFIER</b> , as Unit 7 but 3 ohms £5.12.6	—	—	—
<b>UNIT 6 POWER SUPPLY</b> , as Unit 8 but 18-24 Volts £2.12.6	—	—	—
<b>ALL FOUR UNITS WITH PANEL 3 ohms</b> £14.5.0 (H.P.P. £15.7.0)	57/-	12	20/10
SEND FOR LEAFLET OF COMPLETE RANGE			

## ARMSTRONG AMPLIFIERS AND TUNERS



	Dep.	&	Mthly. pmts. of
<b>MODEL 222</b>			
<b>STEREO AMP. 222, 10 + 10 w. TUNERS SELF-POWERED</b>	£27.10.0	£29.14.0	110/- 12 40/4
224 F.M. ....	£22.10.0	£24.6.0	90/- 12 32/2
223 AM/FM TUNER/AMPLIFIERS, MONO	£28.15.0	£31.1.0	115/- 12 42/2
127/M AM/FM with 5 watt amp ...	£26.10.0	£28.12.0	106/- 12 38/10
227/M AM/FM with 10 w. amp ...	£36.15.0	£39.13.0	147/- 12 53/10
<b>TUNER/AMPLIFIERS, STEREO</b>			
127/S AM/FM with 5 + 5 w. amp	£37.10.0	£40.10.0	150/- 12 55/-
227/S AM/FM with 10 + 10 w. amp	£52.15.0	£56.19.0	211/- 12 77/4
226/S as 227/S with Mag. P.U. ....	£61.0.0	£65.16.0	260/- 12 88/-
Teak Case for any of above ..... £3.10.0			

### MONO AMPLIFIERS

	Dep.	&	Mthly. pmts. of
Linear L 45/A, 3 valve, 3 watt. ...	£6.6.0	—	—
Dulci GA5, Integrated, 5 watts ...	£13.2.6	£14.3.6	52/6 12 19/3
Tripletone Hi Fi Major, 10 watts	£15.18.9	£17.3.9	64/9 12 23/3
Leak TL12, 10 watt Main Amp ...	£20.0.0	£21.12.0	80/- 12 29/4
Leak Varislope Mono, Pre-amplifier	£15.15.0	£17.0.0	63/- 12 23/1
Dulci DPA15, 15 watt	£26.5.0	£28.7.0	105/- 12 38/6
Quad Main Amp. ....	£22.10.0	£24.6.0	90/- 12 33/-

### STEREO AMPLIFIERS

	Dep.	&	Mthly. pmts. of
Leak Stereo 20, Amp and Pre-amp	£55.9.0	£59.17.0	229/- 12 80/8
Leak Transistor Stereo 30	£49.10.0	£53.9.0	198/- 12 72/7
Quad Control Unit	£25.0.0	£27.0.0	100/- 12 36/8

### F.M. TUNERS

	Dep.	&	Mthly. pmts. of
Tripletone, F.M. Tuner Less power	£13.19.6	£15.2.0	56/- 12 20/6
Tripletone, F.M. Tuner With power	£15.14.6	£17.0.0	63/- 12 23/1

## GUITAR AMPLIFIERS

	Dep.	&	Mthly. pmts. of
Linear Diatonic 12 watt 2 inputs...	£13.2.6	£14.3.6	52/6 12 19/3
Linear Conchord 30 watt 2 inputs with Cover	£19.4.6	£20.15.0	77/- 12 28/2
Leak TL 25, 25 w. amp and pre-amp	£42.5.0	£45.12.0	169/- 12 61/11
Leak TL 50, 50 w. amp and pre-amp	£51.5.0	£55.7.0	205/- 12 75/2

## SURBITON PARK RADIO LTD.

48A SURBITON ROAD, KINGSTON-UPON-THAMES SURREY

Phone: KIN 5549

● ORDERS FOR CASH, C O D OR TERMS

● HOURS 9 a.m. to 6 p.m. (1 p.m. Wednesday)

● Easily reached by frequent trains Waterloo to Surbiton

## GRAMOPHONE UNITS

	Dep.	&	Mthly. pmts. of
B.S.R. UA25. Very latest model with cartridge ..... £6.6.0	—	—	—
Garrard as follows:			
SRP10 Single player, Mono cartridge	£6.11.0	—	—
Autoslim, 4 Speed changer Mono	£6.12.6	—	—
AT/5/P Improved Autoslim, Stereo	£9.0.0	£10.0.0	36/- 6 27/4
A.T.6 Autoslim de Luxe, mono	£10.10.0	£11.10.0	42/- 8 23/6
AT/5/3000LM as AT6, but with slim arm, stereo	£11.12.0	£12.12.6	46/6 8 25/9
4H/F, Transcription.....	£17.0.0	£18.7.0	68/- 12 24/11
"Deccadek" Single Player with "Deram"	£15.15.0	£17.0.0	63/- 12 23/1
301 Strobe, Transcription unit ...	£22.0.0	£23.15.0	88/- 12 32/3
Philips AG1016, Stereo cartridge, will change 7in. records with adaptor 10/- extra	£13.13.0	£14.14.0	55/- 12 19/11
Goldring GL58, with arm but less cartridge.....	£17.1.0	£18.8.0	69/- 12 24/11
Goldring GL70, with arm but less cartridge.....	£27.9.4	£29.12.4	111/4 12 40/1
Goldring "8", Transcription less arm	£18.18.5	£20.8.5	76/5 12 27/8
LEAFLETS ON REQUEST			

## Hi Fi LOUDSPEAKERS

	Dep.	&	Mthly. pmts. of
Goodmans Maxim	£17.10.6	£18.18.6	70/- 12 28/8
Goodmans Maxiom	£17.10.0	£18.18.0	70/- 12 25/8
Goodmans Axiette, 8 in. ....	£5.10.11	—	—
Goodmans Axiom, 10 in. ....	£6.12.3	—	—
Goodmans 5K/20/XL, Tweeter and Crossover	£7.7.0	—	—
Goodmans 201, 12 in. 15 watt.....	£11.8.9	£12.8.9	46/9 8 25/3
Goodmans 301, 12in. 20 watt	£15.18.9	£17.3.9	64/9 12 23/3
Goodmans X05000	£2.0.11	—	—
Goodmans X0950	£5.10.11	—	—
W.B. HF812, 8in., 3.75, 7.5 and 15 ohms	£3.16.6	—	—
W.B. HF1012, 12in., 3.75, 7.5 and 15 ohms	£4.12.0	—	—
Wharfedale Super 3, Tweeter ...	£5.16.8	—	—
Wharfedale Super 5, Tweeter ...	£5.19.7	—	—
Wharfedale Super 8 RS/DD	£6.14.2	—	—
Wharfedale Super 10 RS/DD	£10.18.0	£11.18.0	44/- 8 24/3
Wharfedale Super 12 RS/DD.....	£17.10.0	£18.18.0	70/- 12 25/8
Wharfedale RS/12/DD, 12in. unit Full range	£11.10.0	£12.10.0	46/- 8 25/6
LEAFLETS ON REQUEST			

## GUITAR SPEAKERS

	Dep.	&	Mthly. pmts. of
Fane, 12in. Heavy duty unit 20 watt	£5.5.0	—	—
Goodmans Audiom 51, 12in. 15 watt Bass	£9.12.5	£10.12.6	38/6 6 29/-
Goodmans Audiom 61, 12in. 20 watt Bass or Lead	£15.0.0	£16.4.0	60/- 12 22/-
Goodmans Audiom 81, 15in. ....	£25.6.3	£27.6.3	102/3 12 37/-
Goodmans Audiom 91, 118in. 50 watt Bass	£28.11.0	£30.16.10	115/10 12 41/9
Wharfedale W 12/EG, 12in. 15 watt Lead	£10.10.0	£11.10.0	42/- 8 23/6
Wharfedale W 15/EG, 15in. 15 watt Bass	£17.10.0	£18.18.0	70/- 12 25/8
WRITE FOR GOODMAN'S ELECTRIC GUITAR LEAFLET			

# Nowhere in the entire

## I . . . a smaller set to build than the **SINCLAIR MICRO-6**

Until you have built and used the Micro-6, you will never know how exciting this British-designed set is. Its range and power will amaze you as station after station pours in; you will find yourself able to enjoy radio where other sets often cannot be used at all. The two self-contained batteries will give 70 hours or more working life. Bandsread tuning over the higher frequency end of the M.W. Band enables Luxembourg to be tuned in with the ease and power of a local station. Well over 12,000 Micro-6 sets have been built by constructors ranging from advanced electronic engineers to beginners with outstanding success. So start on yours today.

### SMALLER THAN A MATCHBOX, YET . . .

- TUNES IN STATIONS FROM ALL OVER EUROPE
- IS HIGHLY SELECTIVE
- EMPLOYS VERNIER TYPE TUNING
- WEIGHS UNDER 1 oz. COMPLETE WITH BATTERIES
- IS ABSOLUTELY SELF CONTAINED AS SHOWN EXCEPT FOR THE LIGHTWEIGHT EARPIECE
- OUTPUT CAN BE FED INTO AN AMPLIFIER OR TAPE RECORDER IF DESIRED

### CIRCUIT DESCRIPTION

The Micro-6 uses only three Micro-Alloy Transistors in a unique and very efficient 6-stage circuit as follows: Two stages of R.F. amplification are followed by an efficient double-diode detector which drives a high-gain 3-stage A.F. Amplifier. Powerful A.G.C. applied to the first R.F. stage ensures fade-free reception from the most distant stations tuned in. Everything including ferrite-rod aerial and batteries contained within the elegant tiny white, gold and black case. Inserting the earphone plug switches the set on.

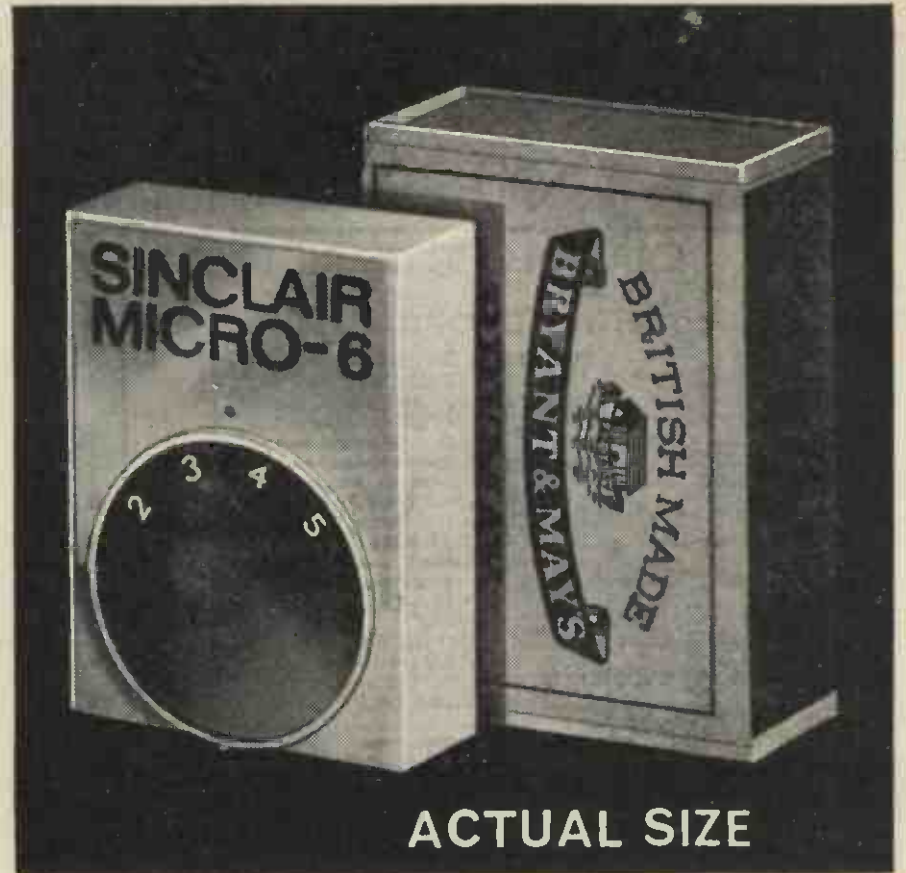

ACTUAL SIZE

ONLY 1 1/2" x 1 1/8" x 1"

### MICRO-6 USERS WRITE

"My pleasure at the way it works is only exceeded by the pleasure it gave me in building and at being able to complete such miniature work satisfactorily."  
W.J.R., Warwick.

"It took me 75 minutes to build, which, I think, is good proof of the thoroughness yet simplicity of your instructions!"  
D.A.B., Solihull.

"It works far better than I had hoped and all my friends are amazed at the reception."  
J.A., Windsor.

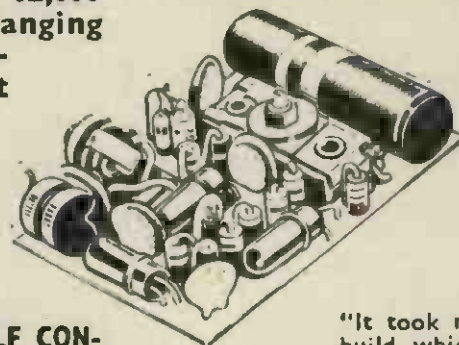

### BUILD IT IN AN EVENING!

Building is simple. All parts including lightweight earpiece, case and dial, and 8-page instructions manual come to

Sinclair "Transrista" well-styled, strong black nylon wrist strap **7/6**

Mallory Mercury Cell Type 1/11 Pack of 6 ZM312 (2 required) each **10/6**

# 59/6

## SINCLAIR TR750 POWER AMPLIFIER

For use with Micro-6

THE TR750 enables the Sinclair Micro-6 Receiver (or the Sinclair Slimline which is an extra-easy set to build, and which comes to 49/6) to be used as a powerful car, domestic or portable loudspeaker set. A connecting plug is provided for this. The TR750 also has many other applications such as a record reproducer, intercom or baby alarm. An output of 750 milliwatts for feeding into a standard 25-30Ω loudspeaker requires an input of only 10mV. Frequency response 30-20,000 c/s ± 1dB. Power required—9 to 12 volts.

386

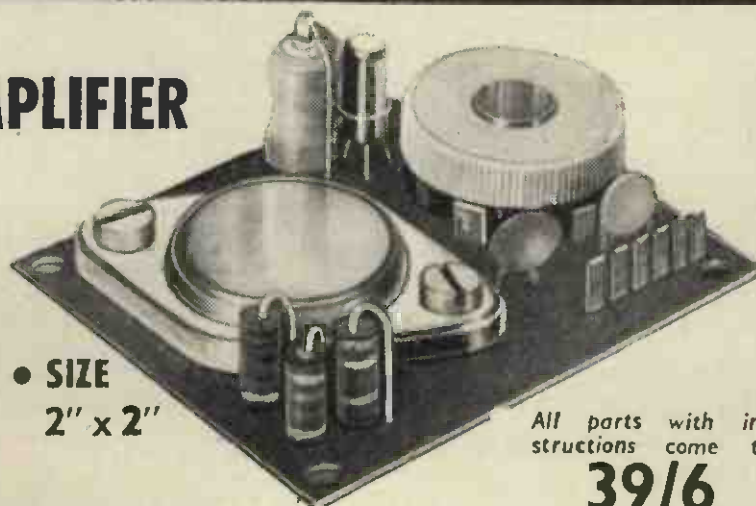

● SIZE  
2" x 2"

● IDEAL ALSO WITH SINCLAIR SLIMLINE

All parts with instructions come to

**39/6**

Ready built and tested with instructions

**45/-**

## SINCLAIR MICRO-INJECTOR

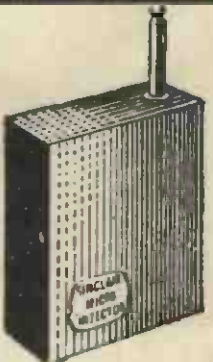

This ingeniously designed device generates and injects a test signal into any part of audio or radio equipment at any frequency from 1kc/s to 30 Mc/s by means of which it becomes easy to locate faults rapidly and accurately. Measures 1 1/2" x 1 1/2" x 1/2", excluding probe. With full instructions. No constructor should be without a Micro-Injector—it's a wonderful aid at all times.

Parts and instructions come to

**27/6**

Ready built and tested

**32/6**

# World will you find...

② . . . a constructor's amplifier using PWM, except for the

## SINCLAIR X-10

**INTEGRATED 10 WATT AMPLIFIER AND PRE-AMP**

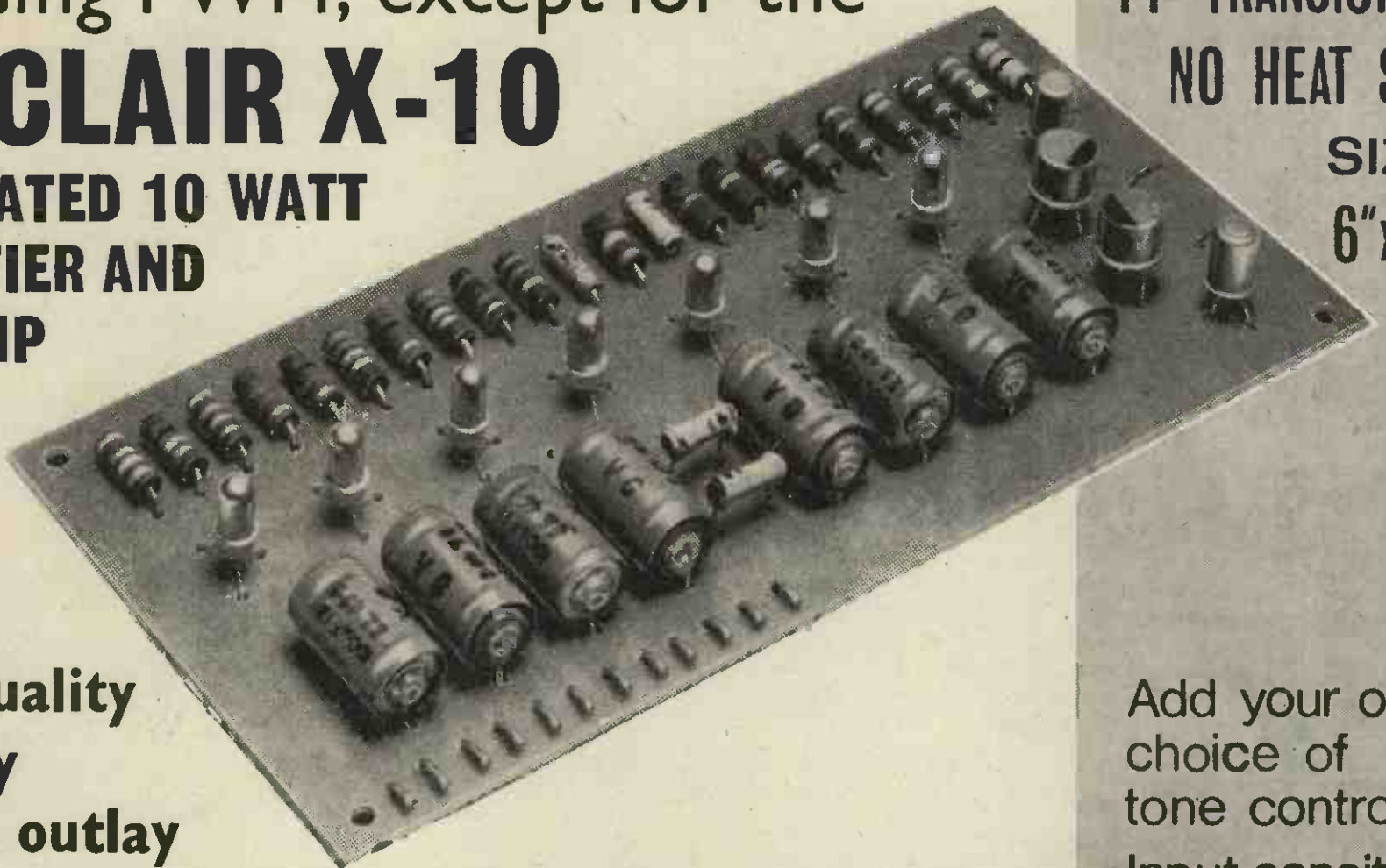

**11 TRANSISTORS  
NO HEAT SINK  
SIZE  
6" x 3"**

**Hi Fi Quality  
for very  
modest outlay**

The Sinclair X-10 marks a radical departure from conventional amplifier design which is certain to influence future developments in the audio field enormously. Already the power and quality obtainable from this extremely small amplifier bring entirely new approaches to styling and housing domestic audio equipment, which the absence of heat sinks helps greatly.

Leaving the X-10 user to add a tone control system of his own choice to the integrated pre-amplifier stage enables any sound input source to be accurately matched. The X-10 has many other important advantages as a result of using Pulse Width Modulation, including incredibly low distortion figures, no falling off of higher frequencies, better tran-

sients and less current requirements. Indeed, the X-10 can be satisfactorily operated from a couple of 4/- lantern batteries. **THE SINCLAIR X-10 MANUAL** included with every X-10 explains how it functions, and also gives tone control and stereo matching circuits, none of which cost more than a few shillings. The X-10 Manual is available separately, price 1/-.

### ● X-10 USERS WRITE

"I must say that the amplifier certainly delighted myself and others with its beautiful crisp quality."  
W.L., Leeds, 2.

"I was able to try it out yesterday and would like to say that I am very pleased with its performance."  
R.M., Keighley.

Add your own choice of  
tone control  
Input sensitivity  
1mV into 1kΩ  
Total harmonic distortion <0.1%  
Output up to  
10 watts into 15Ω  
Operates from  
12 to 15 volts D.C.

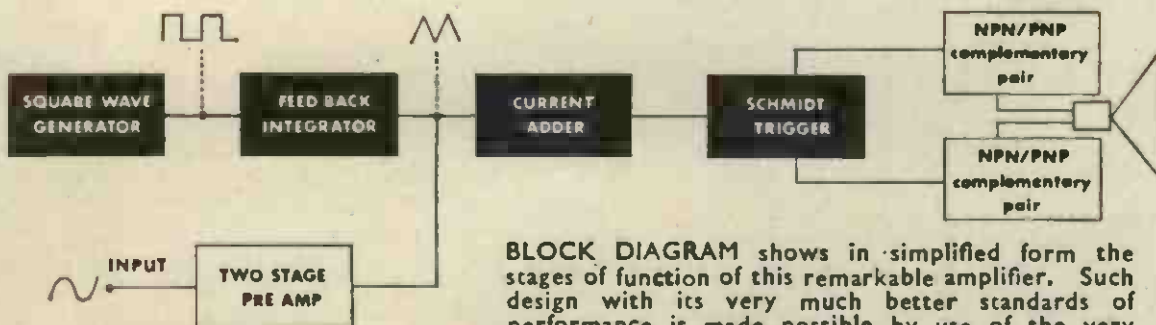

**BLOCK DIAGRAM** shows in simplified form the stages of function of this remarkable amplifier. Such design with its very much better standards of performance is made possible by use of the very latest in transistors and high quality components.

All parts including 11 transistors and X-10 Manual come to

**£5.19.6**

Ready built and tested with X-10 Manual

**£6.19.6**

A.C. Mains Supply Unit (ready built) for one or two X-10s **£2.14.0**

**POST YOUR  
ORDER  
TO-DAY!**

To **SINCLAIR RADIONICS LTD., COMBERTON, CAMBRIDGE**

Please send items detailed below:— £ s. d.

.....  
.....  
.....

TOTAL £

For which I enclose CASH/CHEQUE/MONEY ORDER

NAME..... 387

ADDRESS.....

Full Service Facilities always available to Sinclair Customers

## ETCH YOUR OWN PRINTED CIRCUIT KIT



2/1-  
Post free  
Each contains over 60 sq. in. of laminated board and sufficient chemicals to make dozens of printed circuits, plus comprehensive instruction book giving advice and examples on translating theoretical circuits into layouts ready for etching. High quality materials—completely safe to handle—carefully prepared to ensure fine definition and uniform results without laboratory control

## ELECTROLUMINESCENCE

2 The lighting of tomorrow previewed in your home NOW!  
6/6 each Post Free

Electroluminescent lamps—an amazing new scientific development in which the whole of the illumination produced emanates from the entire surface of a specially treated, flat steel plate protected by a thin coating of glass. No heat is generated and there is no filament to burn out. Makes intriguing home decoration, illuminated door numerals, small darkroom lights, night-lights, etc. Connects directly to mains and burns continuously for a whole year at a cost of a few pence only. Available in plate size 3 in. x 2 in. and in green or blue colour (state which required). Each plate takes one numeral (stick-on number of choice supplied free if required). Complete with plastic protecting wrap and full instructions.

Make a wonderful range of inexpensive devices

## with DRY REED SWITCHES

Can be actuated by permanent or electromagnets to provide excellent basis for a wide range of inexpensive devices such as burglar alarms, limit switches, door bell switches, etc. Tremendous reliability factors and a working life of about 100 times that of microswitches and the uses to which they can be put is limited only by imagination. Each switch supplied complete with specification, instructions and ideas information. **SUITABLE MAGNETS 1/- extra.**

**REED SWITCH COILS 4/- post free**  
Specially manufactured to provide electro-magnetic operation of Dry Reed Switch described above. Coil is simply pushed on to glass tube and centrally located over switch contacts. Works from any 4-12 v. D.C. supply. Size overall 1/2 in. diam. x 1/2 in. long.

## MINIATURE MAINS INDICATOR LIGHTS 4 for 5/- Post free

Give positive indication that equipment tools, instruments, apparatus, etc., is switched on. Complete assembly of neon, resistor, insulation and flying leads that requires only connection to switch. Small size and insulation permit simple fitting—just drill small hole in panel or tape or clip to equipment. Current consumption negligible. New manufacture.

## Semi-conductor module ICE CUBE SIZE ENCAPSULATED CIRCUIT

Solid state semi-conductor modules—fully transistorised and completely wired and tested circuits that only require a 6-volt battery and connection to input and output to provide a compact ready-made unit. Encapsulated types are shockproof and almost indestructible. Supplied with instructions.

**PUBLIC ADDRESS AMPLIFIER**—needs only crystal microphone and any speaker. Frequency response designed to provide maximum intelligibility. With 15 in. speaker sound covers hundreds of yards. Fully encapsulated. Size only 1 1/2 x 1 1/2 x 1/2 in. 30/-. P. & P. 1/-.

**METRONE**—required only 2 megohm potentiometer and any PM speaker to produce accurate repetitive beats at adjustable rates from 40 to more than 208 beats per minute. Low battery drain, simple connections. 22/6. P. & P. 1/-.

**2 WATT GRAM AMPLIFIER**—just connect to any crystal pick-up and 8-ohm speaker for above average output with excellent tonal quality. 1-megohm potentiometer recommended for vol. control. Compact, high quality unit. 30/-. P. & P. 1/-.

**CODE PRACTICE OSCILLATOR**—simply connect with morse key, any P.M. speaker and any 1 1/2-6v battery. Fully transistorised and assembled on rigid board size 2 x 1 1/2 in. 12/6

**BURGLAR ALARM**—needs only 8-ohm loudspeaker, switch and microswitch (or reed switch and magnet) to complete. Operation of sensing switch trigger upward screaming syren to give instant alarm. For home or motor car protection. 30/-. P. & P. 1/-.

**FIRE ALARM**—module contains temperature sensor and operates in conjunction with 8-ohm loudspeaker and 2 megohm potentiometer. Increase of room temperature above pre-set level immediately triggers screaming syren alarm. 30/-. P. & P. 1/-.

## Make simple AUTOMATIC CONTROLS with

## CADMIUM SULPHIDE PHOTO-CELLS

New, inexpensive photo-conductive cells act as light sensitive resistors that increase conductivity with increased light. 1,000 times more sensitive than selenium cells with greater reliability, and can easily be built into a wide range of simple circuits. Typical uses include: automatic light controls, exposure meters and many other devices. Requires simple low power source from battery or mains transformer. Two types available: **Type 1:** Max. voltage 200 v. Output 0.5 watt. Sens. range 400-800 mu. 10/- post free. **Type 2:** Max. voltage 150 v. Output 0.15 watt. 8/6d. post free. Both types have a resistance range of 5 megohms at zero to 500 ohms at 1,000 lux. Sensitive range is 400-800 mu. Supplied with specification, instructions and typical circuits.

# SOLON GETS THINGS TOGETHER FOR GOOD

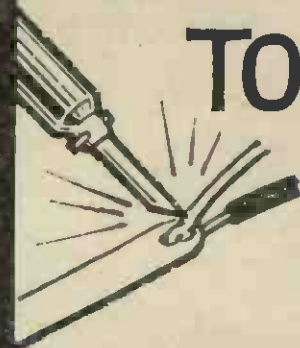

SOLON ELECTRIC SOLDERING IRONS are made by AEI. Seven models suitable for all soldering jobs. The 15 and 25 watt for radio work, the 65 watt for heavier duties. All parts are replaceable. Prices from 24/8.

**SOLON**  
TRADE MARK

From your radio or electrical supplier.

## TAPE RECORDER COVERS



Smart waterproof cover to give complete protection to your tape recorder. Made from rubberised canvas in navy, wine, tan, grey and bottle green with white contrasting pipings, reinforced base, handy zip microphone pocket and name panel.

Grundig TK 1	... 49/6	Telefunken 85	... 65/-	Cossor 1604	... 79/-
" TK 5	... 55/-	" 75/15 &		" 1605	... 84/-
" TK 6	... 67/6	" 76K	... 55/-	Stella ST455	... 63/-
" TK 8	... 63/-	" 95	... 69/6	" ST454	... 57/6
" TK 14		Philips 8108	... 57/6	" ST458	... 79/-
" & 23 & 18	59/6	" 3548	No Price	" ST459	... 84/-
" TK 20	... 52/6	" 3534	... 87/-	Saba	... 63/-
" TK 24	... 55/-	" 3459	... 79/6	Elizabethan FT1	... 66/-
" TK 25	... 55/-	" EL3538	... 63/-	" FT3	... 75/-
" TK 30	... 60/-	" EL3542	... 63/-	" LZ29	... 75/-
" TK 35	... 63/-	" EL3536	... 70/-	Fi-Cord IA	... 52/6
" TK 40 & 41	66/-	" EL3515	... 57/6	Fidelity Argyle	... 55/-*
" TK 46	... 82/-	" EL3541/15	57/6	Clarion (with strap)	52/6
" TK 55	... 63/-*	" 3541/H	... 72/-	Brenell Mk. 5	... 77/-
" TK 60	... 75/-*	" Starmaker	66/-	" 3 star	... 69/-
" TK 830/3D	63/-	Cossor 1602	... 57/6	Truvox R92 and 94	99/-
" Cub	... 35/-*	" 1601	... 63/-	Robuk RK3	... 67/6
				Ferroglyph	... 88/-
				Sony 521	... 90/-
				Revox	... 84/-
				Optacord 414-412	63/-

\* Without pocket

## A. BROWN & SONS LTD.

24-28 GEORGE STREET, HULL. TEL.: 25413, 25412

**PROOPS**  
BROUERS LIMITED

52 TOTTENHAM COURT ROAD, LONDON W1.  
PHONE: LANGHAM 0141. HOURS: 9am-6pm  
THURS: 9am-1pm. OPEN ALL DAY ON SATURDAY

# THE WHARFEDALE Super Range

Each loudspeaker in this range is fitted with roll surround for low resonance and double diaphragm assembly for extended HF response.



## SUPER 8/RS/DD

Impedance 10/15 ohms.  
Ceramic Magnet.  
Flux density 14,500 oersteds.  
Total flux 60,000 maxwells.  
Aluminium Voice Coil.  
Max. input 6 watts rms  
or 12 watts peak.  
Frequency range 40-20,000 c/s.  
Bass resonance 50/60 c/s.  
Price: 134/2 inc. P.T.

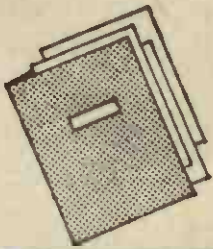

Write for informative and fully illustrated 12 page booklet

## SUPER 10/RS/DD

Impedance 10/15 ohms.  
Flux density 16,000 oersteds.  
Max. input 10 watts rms  
or 20 watts peak.  
Frequency range 30-20,000 c/s.  
Aluminium Voice Coil.  
Bass resonance 38/43 c/s.  
Price: 218/8 inc. P.T.



## SUPER 12/RS/DD

Impedance 12/15 ohms.  
Flux density 17,000 oersteds.  
Total flux 190,000 maxwells.  
Aluminium Voice Coil.  
Max. input 20 watts rms  
or 40 watts peak.  
Frequency range 25-20,000 c/s.  
Bass resonance 26/32 c/s.  
Price: 350/- (no tax).



# Wharfedale

**WHARFEDALE WIRELESS WORKS LTD  
IDLE BRADFORD YORKSHIRE**

Telephone : Idle 1235/6  
Telegrams : 'Wharfdel', Bradford.

# Veroboard

gives  
constructors  
the  
simplest...  
most  
efficient...

**WIRING BASE** for any electronic assembly work — whether experimental or quantity production. Patented Veroboard is an advance on tag board wiring techniques and printed circuits, and because of its absolute stability under all conditions it is in fact now extensively used by manufacturers all over the world instead of printed circuits.

A sample of Veroboard is provided FREE in this issue of Practical Electronics and it is obtainable in many sizes of which 4 are available through the retail trade. For the name and address of your nearest Retailer please write to:—

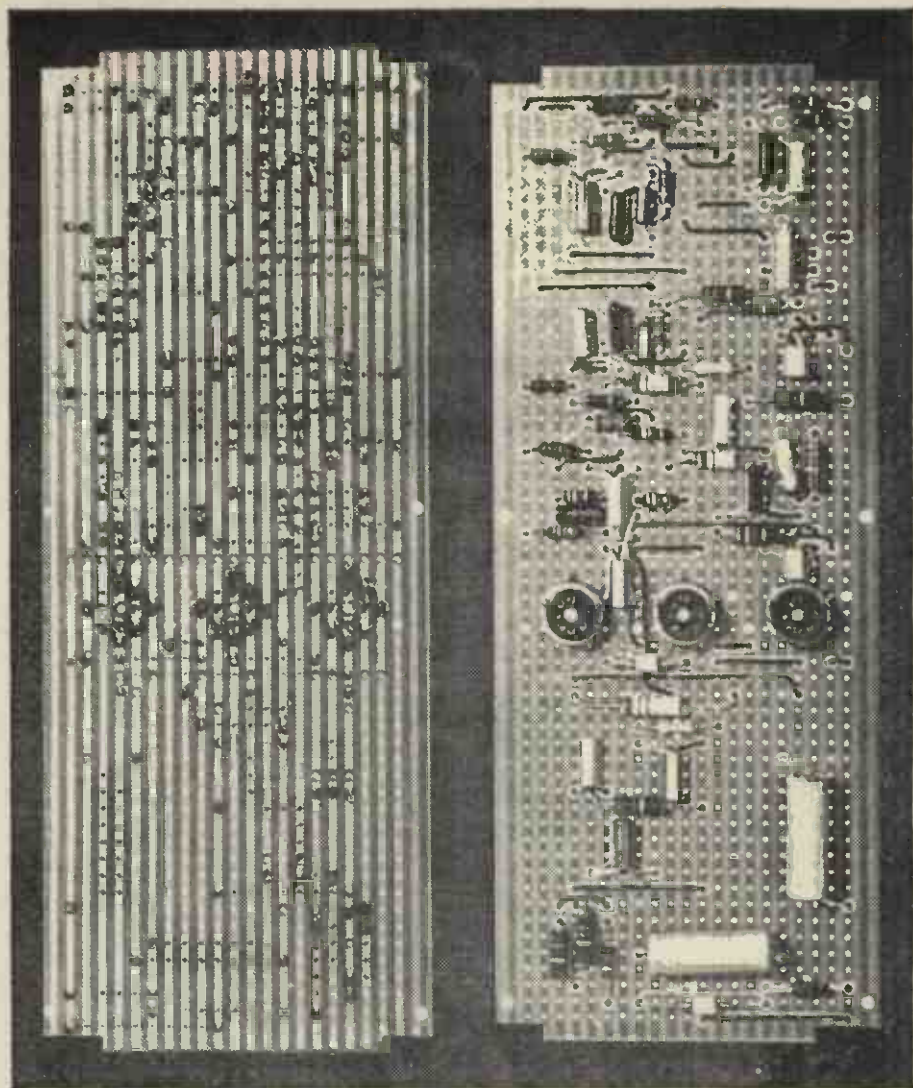

**VERO ELECTRONICS LTD.** (DEPT. P2)  
SOUTH MILL ROAD, REGENTS PARK, SOUTHAMPTON  
TEL. 71061 TELEX 47593  
ENQUIRIES FROM RETAILERS AND MANUFACTURERS WELCOMED



BRAND

HAND AND FOOT-OPERATED SEALING TOOLS  
FOR ALL KINDS OF PLASTICS

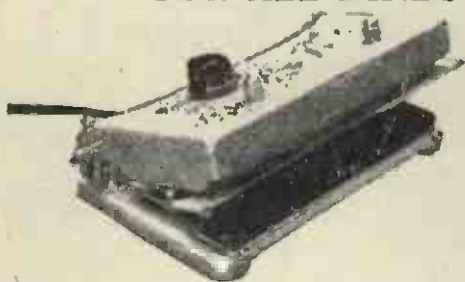

The "PACKFIX" for cellophane and polythene bags. Hand or foot-operated, all voltages. From £10.

FLT cellophane and polythene bag sealer. Foot operated or magneto electrically driven. Seals bags up to 15 1/4" width. From £42.

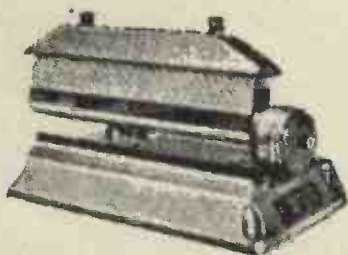

Hot plates thermostatically controlled. Small and large sizes for cellophane, polythene and shrinking foils. From £12.

LET US SOLVE YOUR SEALING PROBLEMS.  
WRITE FOR COMPLETE ILLUSTRATED LISTS  
TO DISTRIBUTORS:

S. KEMPNER Ltd., 384 FINCHLEY RD., LONDON, N.W.2  
TEL.: HAM 6365

## SOLDER WITH PRIMAX and PRIMAXA SUPER EFFICIENT SPOTLIGHT SOLDERING GUNS



PRIMAX  
60W SPOTLIGHT  
86/8 ea.

PRIMAXA  
100W SPOTLIGHT  
112/8 ea.

NEW ADDRESS!

Distributors: S. KEMPNER LTD  
384 FINCHLEY ROAD, LONDON, N.W.2. Tel.: HAM 6365



# L. K. ELECTRONICS

## The Cheapest—The Best—Quickest Service

● Famous Autochanger or Single Player Units supplied with brand new, two-tone, de-luxe portable cabinets, 17×15×8½in. Strong carrying handle, gilt finish clips and hinges are used by famous make for 22-gn. model. Ready cut out motor board, 14×13in. Front baffle 7×4in. High flux loudspeaker and 3 watt amplifier. Amplifier ready built on metal chassis with output transformer, volume and tone controls. All items fit together perfectly. Assembly in 30 minutes. Only 5 wires to join. 12 months' written guarantee. Available separately or package deals as below.

Our NEW MK II Superb Kits are now being dispatched.

### L K PRICES FOR COMPLETE KITS:

**Autochanger Kits as above**  
 B.S.R. U.A. 14, T.C. 8 Mono..... £10.15.0 P.P. 5/6  
 Garrard Autoslim, Mono ..... £11.7.6 P.P. 5/6

**Single Player Kits as above**  
 Garrard S.R.P. 10, Mono ..... £10.12.6 P.P. 5/6  
 E.M.I. Autostop, Mono ..... £10.17.6 P.P. 5/6

Individual Prices for those who wish to purchase separately.  
 Record Player Cabinet with Cut-out Board ..... £3.10.0 P.P. 3/6  
 Amplifier with 7×4in. speaker ..... £3.10.0 P.P. 2/6

● **SCOOP!** B.S.R. U.A. 25 Autochangers. T.C. 8 Mono P.U. Brand new and boxed. Wired for stereo. Note OUR price £5.15.0. P.P. 5/-. The very, very latest model.

● **SCOOP!** B.S.R. U.A. 14 Autochangers. T.C. 8 Mono P.U. Brand new and boxed. Wired for stereo. Note OUR price £5.10.0. P.P. 5/-. Latest model.

● **SCOOP!** Garrard Autoslim. Mono P.U. Brand new and boxed. Wired for stereo. Latest model. Note OUR price £6.5.0 only. P.P. 5/-.

● **SCOOP!** Garrard A.T.5. Wired for stereo, inclusive of head and mono cartridge (A.T.5 is an auto transcripator). The finest changer of them all. OUR price, brand new and boxed, £7.10.0 only. P.P. 5/-.

### AUTOCHANGERS

**Single Players**  
 E.M.I. Autostop, Mono ..... £5.10.0 P.P. 4/6  
 Garrard S.R.P. 10, Mono ..... £5.10.0 P.P. 4/6  
 E.M.I. Separate Pick-up ..... £3.5.0 P.P. 3/6  
**Transcription Units—Stereo Head—Mono**  
 Garrard 4 H.F. Stereo ..... £15.10.0 P.P. 5/-  
 Philips A.G. 10/16. Stereo ..... £12.10.0 P.P. 5/-  
 Garrard A.T.6, Stereo ..... £10.10.0 P.P. 5/-  
 Garrard 301..... £16.10.0 P.P. 5/-

● **SCOOP!** Record Player Cabinets. Two-tone, de-luxe finish with cut-out board. These are brand new and product of very famous national manufacturer. OUR price £3.5.0 only. P.P. 3/6.

● **SCOOP!** 3-watt Gramophone Amplifier. Complete with 5in. Speaker, 49/6. P.P. 5/-.  
 The amplifier is complete, on a fabric-covered baffle board. Output transformer included. Tone and volume controls and on/off switch. Ready to switch on and play. Terrific volume. Size 12½in.×6in.×3½in. back to front. For 200-250 v. A.C. Output 3 watts.

● **SCOOP!** Diodes—over 1,000,000 in stock—ideal substitute O.A.81 vision detector.  
 Note OUR price £1.0.0 per 500. P.P. 2/-. (In 500 lots only).

● **SCOOP!** Transistor Tape Recorder. The best obtainable by very famous manufacturer. Brand new, boxed, guaranteed. Reduced from 12 gns. OUR price £7.10.0. P.P. 3/6. Complete with microphone, tape, batteries and operational booklet. Features push-pull amplifier, two motors, single switch operation, pause, speed, wind, rewind, record, play back. Can be used in any position, indoor or outdoor.

● **SCOOP!** Hi-Fidelity Speakers, 15-watt. Very famous national manufacturer—we cannot mention name. 45-13,000 c.p.s., 3 or 15 ohm voice coils, response 45-13,000 c.p.s. Magnet 15,000 lines. In carton—unopened and unused. OUR price £4.4.0 only. P.P. 4/6.

● **SCOOP!** A Stereophonic Amplifier with the following features. A twin ganged tone control in a special negative feedback circuit, giving a wide range of tone correction. A balance control enabling the amplifiers to be equalized in output to compensate for pick-up, lead, speakers, recording differences. A speaker switch. M1, single amplifier. M2, dual amplifiers for increased Monaural output. S.3, two speakers at 5 watts per channel. Twin gauged volume controls and all four controls placed equidistant along the front of the chassis. Designed, made and guaranteed by Brittamer Ltd. Brand new and at a fraction of original cost. OUR price £7.10.0 only. P.P. 4/6.

### THE SIOUX 60 WATT MULTI-PURPOSE AMPLIFIER

IDEAL FOR GUITAR—BASS OR LEAD—ORGAN—VOCAL GROUP—PUBLIC ADDRESS

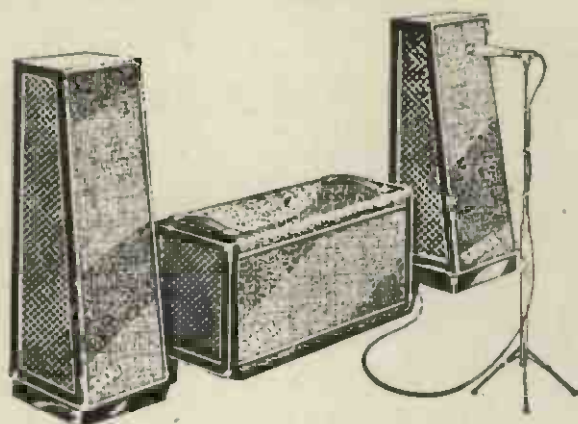

ONLY

39 GNS.

CARR. & PACKING EXTRA

Incorporating Ten High Duty Speakers in two columns of five designed to handle efficiently the full output of Amplifier at frequencies down to 25 c.p.s. Heavily made Cabinet in two-tone Vynair. For 200-250 v. to 50 c.p.s. A.C. Mains operation. Four jack socket inputs and two independent volume controls for simultaneous connection of up to four instrument pick-ups or microphones. Level frequency response throughout the Audible Range. OUR INCLUSIVE PRICE FOR AMPLIFIER, MIKE, STAND, SPEAKERS, LEADS, ETC. (NO H.P.). ONLY 39 GNS.

● **SCOOP!** Cartridges—Ceramic Diamond Styli—Stereo—By Acos. Limited Number only at one ¼ of original price—15/- only +P.P. 1/-. While stocks last.

Speakers ex Equipment. 5in. 5/-, 7in.×4in. 6/-, 6in. 6/6, 8in. 7/- P.P. 1/6 each.

● **SCOOP!** A Limited Number Only. Tape Decks by B.S.R. Latest model. A.C./200/240 v. Brand new and boxed. OUR price £6.10.0 only. P.P. 4/6.

● **SCOOP!** 1964 Radiogram Chassis. Stereo 3-wave bands, long, medium, short. 5 watts per channel. 6 valves. Latest Mullard A.C. 200/250 v. Ferrite aerial. Glass dial. Horizontal wording. Size 13in.×4in. Aligned and calibrated. Concentric controls. Isolated chassis. Size 13½in.×9in. high×5in. deep. Product of famous national manufacturer. Brand new and boxed. Maker's guarantee.  
 OUR price £14.10.0. List price £19.8.0. P.P. 5/6. Our Chassis List quotes prices—the keenest in the Trade. We are Main Agents for the complete range of Brittamer Chassis and Amplifiers. "Brittamer"—makers of Radiogram Chassis to the Top Names in Radio.

● **SCOOP!** For 27 gns. only. A fabulous offer. Package Deal Garrard A.T.5 Transcripator, plus 2 12in. 15 watt Hi-Fidelity speakers, plus the very latest Continental push-button chassis by Brittamer. Stereo, 3-wave band, 6 valves, 5 watts per channel. The finest chassis of its type in the world. You will be amazed at performance and quality. We unhesitatingly recommend this chassis. P.P. 21/-.

### TRANSISTOR SECTION

● **SCOOP!** A first-class 2 wave-band 8 transistor superhet chassis by world famous manufacturer. Fully built, aligned, tested, guaranteed. Full coverage long and medium waves. Note OUR price only £6.0.0. P.P. 2/6. Suitable speaker 10/6. P.P. 1/6. A few cabinets can be supplied at 22/6 each. P.P. 2/-. OUR price for the package deal £7.4.0 only. Ideal for Caroline. P.P. 3/6.

S.A.E. enquiries please. Our Complete Lists 1/- only—credited against your order

● IF NOT ADVERTISED IT IS STILL IN STOCK

# L.K. ELECTRONICS (Victoria) LTD.



17 GILLINGHAM ROW, WILTON ROAD, LONDON, S.W.1.



# Why NOT BUILD ONE OF OUR PORTABLE TRANSISTOR RADIOS...

BACKED BY OUR SUPER AFTER SALES SERVICE

## ROAMER SEVEN Mk III

5 WAVEBAND PORTABLE OR CAR RADIO

Amazing performance and specification ★ Now with PHILCO MICRO-ALLOY R.F. TRANSISTORS

● 9 stages—7 transistors and 2 diodes

Covers Medium and Long Waves, Trawler Band and two Short Waves to approx. 15 metres. Push-pull output for room filling volume from rich toned heavy duty "Celestion" speaker. Air spaced ganged tuning condenser. Ferrite rod aerial for M & L Waves and telescopic aerial for S Waves. Real leather-look case with gilt trim and shoulder and hand straps. Size 9 x 7 x 4in. approx. The perfect portable and the ideal car radio. (Uses PP7 battery available anywhere.)

Total cost of parts now only £5.19.6 P. & P.  
Parts Price List and easy build plans 3/- 5/6

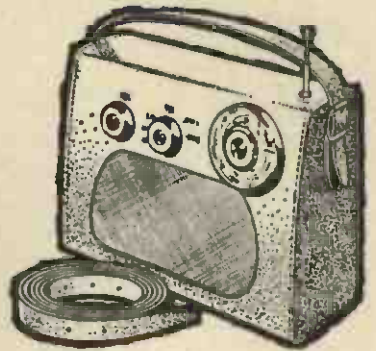

## NEW TRANSONA FIVE MELODY SIX

Home, Light, A.F.N., Lux. all at good volume.

G.P. Durham

● 7 stages—5 transistors and 2 diodes Fully tunable over Medium and Long Waves and Trawler Band. Incorporates Ferrite rod aerial, tuning condenser, volume control, new type fine tone super dynamic 2½in. speaker, etc. Attractive case. Size 6½ x 4½ x 1½in. (Uses 1289 battery available anywhere.)

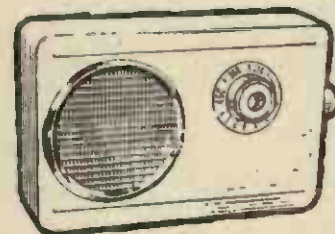

Total cost of all parts now only 42/6 P. & P. 3/6  
Parts Price List and easy build plans 2/-

## POCKET FIVE

● 7 stages—5 transistors and 2 diodes

Covers Medium and Long Waves and Trawler Band, a feature usually found in only the most expensive radios. On test Home, Light, Luxembourg and many Continental stations were received loud and clear. Designed round supersensitive Ferrite rod aerial and fine tone 2½in. moving coil speaker, built into attractive black case with red speaker grille. Size 5½ x 1½ x 3½in. (Uses 1289 battery available anywhere.)



Parts Price List and easy build plans 1/6 Total cost of all parts now only 42/6 P. & P. 3/-

## SUPER SEVEN

● 9 stages—7 transistors and 2 diodes

Covers Medium and Long Waves and Trawler Band. The ideal radio for home, car, or can be fitted with carrying strap for outdoor use. Completely portable—has built-in Ferrite rod aerial for wonderful reception. Special circuit incorporating 2 RF Stages, push-pull output, 3in. speaker (will drive large speaker). Size 7½ x 5½ x 1½in. (Uses 9v battery, available anywhere.)

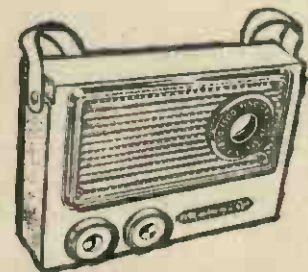

Total cost of all parts now only £3.19.6 P. & P. 3/6  
Parts Price List and easy build plans 2/-

## MELODY SIX

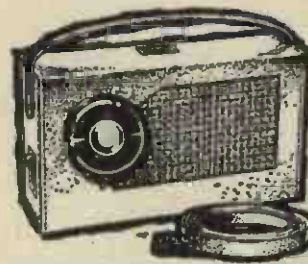

"... amazed at volume and performance, has really come up to my expectations". S.G., Stockton-on-Tees.

● 8 stages—6 transistors and 2 diodes

Our latest completely portable transistor radio covering Medium and Long Waves. Incorporates pre-tagged circuit board, 3in. heavy duty speaker, top grade transistors, volume control, tuning condenser, wave change slide switch, sensitive 6in. Ferrite rod aerial. Push-pull output. Wonderful reception of B.B.C. Home and Light, 208 and many Continental stations. Handsome leather-look pocket size case, only 6½ x 3½ x 1½in. approx. with gilt speaker grille and supplied with hand and shoulder straps.

Parts Price List and easy build plans 2/- Total cost of all parts now only £3.9.6 P. & P. 3/-

## TRANSONA SIX

● 8 stages—6 transistors and 2 diodes

This is a top performance receiver covering full Medium and Long Waves and Trawler Band. Push pull output. High-grade speaker makes listening a pleasure. Ferrite rod aerial. Many stations listed in one evening including Luxembourg loud and clear. Attractive case in grey with red grille. Size 6½ x 4½ x 1½in. (Uses PP4 battery available anywhere.)

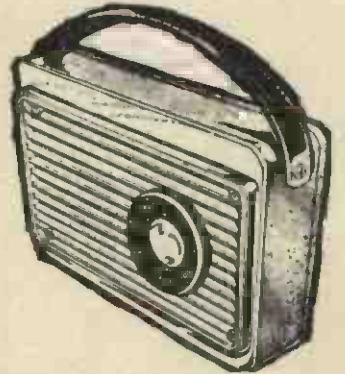

Total cost of all parts now only 59/6 P. & P. 3/6  
Parts Price List and easy build plans 2/-

## ROAMER SIX NEW!!

NOW WITH PHILCO MICRO-ALLOY R.F. TRANSISTORS

● 6 WAVEBAND!!

● 8 stages—6 transistors and 2 diodes

Listen to stations half a world away with this 6 waveband portable. Tunable on Medium and Long Waves, Trawler band and three Short Waves. Push pull output. Sensitive Ferrite rod aerial and telescopic aerial for short waves. Top grade transistors, 3-inch speaker, handsome case with gilt fittings. Size 7½ x 5½ x 1½in.

★ Extra band for easier tuning of LUX., etc.

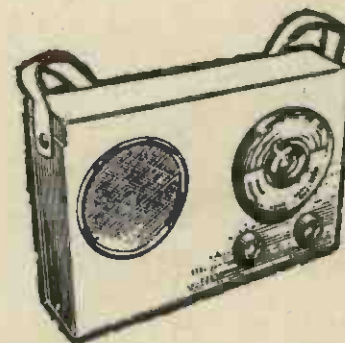

Parts Price List and easy build plans 2/- Total cost of all parts now only £3.19.6 P. & P. 3/6  
(Carrying Strap 1/6 extra.)

All components used in our receivers may be purchased separately if desired. Parts price lists and easy build plans supplied free with sets of parts or available separately at fixed prices stated.

### COMPONENT BARGAINS

#### TRANSISTORS

PHILCO MADT Type 2N1727  
Maximum frequency of oscillation 150 Mc/s ... 8/6

PHILCO MADT Type 2N1728  
Maximum frequency of oscillation 150 Mc/s ... 9/6

PHILCO MADT (Micro Alloy Diffused) Type 2N503  
Maximum frequency of oscillation over 500 Mc/s ... 15/-  
Diodes ... 1/6  
Standard interleaved o/p transformers for valve o/p stages 3/6

#### SWITCHES

Slide, single pole, heavy springs 2/- Post 3d  
Yaxley 6-way, 2 pole 4/6 Post 3d

#### TUNING CONDENSERS

Air spaced fine quality German manufacture with slow motion drive. 0.0005 with oscillator section ... 5/6 Post 1/-

Subminiature similar 00 with tuning and oscillator sections 6/6 Post 1/-

Subminiature mica dielectric with trimmers. Tuning 200 pf, Oscillator 50 pf 4/6 Post 1/-  
Mica dielectric 0.0003 mfd. 2/9 Post 6d

#### DIALS AND KNOBS

3in. dial with polished brass insert and M/L calibrated disc 6/6

1in. cream knobs with polished brass insert and rim 1/3 each

# RADIO EXCHANGE Ltd.

61a, HIGH STREET, BEDFORD. Phone: 2367

Callers side entrance  
Barratts Shoe Shop  
Open 9—5 p.m.  
Sats. 9—12.30 p.m.

# JASON KITS

Jason tuners and test equipment offer a wide choice of models designed to meet present-day requirements and are a delight to build.

**JTV2 SWITCHED TUNER.** All BBC f.m. transmissions and BBC-1 and ITV television sound channels at the turn of a switch. All components including turret and coil plate but less four valves



£14. 0s. 4d.

**JTL TAPE PREAMPLIFIER** designed to suit any tape deck or head. Will simultaneously record and playback stereo or mono using two or four track heads. All components including valves £22. 1s. 0d. Ready built and tested. £30. 9s. 0d.

**OTHER JASON KITS**

FMT1 F.M. Tuner, less valves	£5. 19s. 0d.
FMT2 F.M. Tuner, less valves (less power supply components)	£9. 9s. 0d. £7. 15s. 0d.
FMT3 F.M. Tuner, less valves (less power supply components)	£10. 9s. 0d. £8. 15s. 0d.
MERCURY 2 Switched tuner, less valves	£9. 15s. 4d.
ARGUS Transistor m.w. tuner, complete	£7. 10s. 0d.
AG10 Audio generator, complete	£15. 19s. 0d.
OG10 Oscilloscope, less c.r.t.	£18. 10s. 0d.
W11 Wobulator, complete	£14. 19s. 0d.
EM10 Valve voltmeter, complete	£23. 0s. 0d.
SB26 Tape deck (built only) 1/2" track mono	31 gns.
4 track stereo	39 gns.

Write for descriptive leaflets and name of nearest stockist

**Jason Electronic Designs Ltd.**

18 Tudor Place, Tottenham Court Road  
London, W.1 Telephone: MUSEum 4666/8



## MULTIMINOR *Mk 4*

The newly improved model of this famous AVO pocket size multi-range instrument has been enthusiastically acclaimed in all parts of the world for its high standards of accuracy and dependability as well as for its modern styling, its highly efficient internal assemblies and its resistance to extremes of climatic conditions.

It is simple to use, one rotary switch for instant range selection, only one pair of sockets for all measurements, and a 2 1/2-inch clearly marked scale-plate. It is supplied in an attractive black carrying case complete with interchangeable test prods and clips, and a multi-lingual instruction booklet.

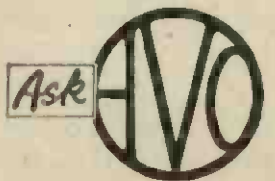

RESISTANCE: 0-2MΩ in 2 ranges, using 1.5V cell  
SENSITIVITY: 10,000Ω/V on d.c. voltage ranges  
1,000Ω/V on a.c. voltage ranges

to send you a full specification of this great little instrument. It measures only 7 1/2 x 4 x 1 1/2 ins. and weighs only 24 ozs.

**AVO LTD**

AVOCET HOUSE · 92-96 VAUXHALL BRIDGE ROAD · LONDON S.W.1  
Telephone: VICtoria 3404 (12 lines)

MM19



## D.I.Y. with GOODMANS HIGH FIDELITY MANUAL

A Practical Guide to  
full listening enjoyment.

The Manual is much more than a catalogue of Goodman's High Fidelity Loudspeakers—it contains practical and informative articles. Those of particular interest to the D.I.Y. enthusiast include special beginners page, advice on stereo, stage-built systems and full cabinet drawings. Whether building or improving your own audio set-up or choosing a complete speaker system, you'll find it useful and interesting as well as informative. Ask or Write for your FREE copy.

Please send me a free copy of the Goodman's High Fidelity Manual

Name .....

Address .....

P.E.4.

**GOODMANS**

GOODMANS INDUSTRIES LIMITED  
Axiom Works, Wembley, Middlesex  
Telephone: WEMbley 1200  
A Member of the Rentaset Group

# THE LINEAR 'SUPER 30' HIGH FIDELITY PUBLIC ADDRESS AMPLIFIER

## TECHNICAL DETAILS:

### SENSITIVITY FOR 30 WATTS

Gram. — 50 millivolts  
 Mic. 1 5 "  
 Mic. 2 150 microvolts

### FREQUENCY RESPONSE

± 2 d.b. 30 c.p.s. —  
 20,000 c.p.s.

### BASS CONTROL

+15 d.b. to -15 d.b. at  
 50 c.p.s.

### TREBLE CONTROL

+12 d.b. to -12 d.b. at  
 10 Kcs.

### HUM AND NOISE

-60 d.b.

### HARMONIC DISTORTION

0.5% for 30 watts

### VALVES

Mullard ECC83, ECC83,  
 ECC83, EL34, EL34, GZ34

### NEGATIVE FEEDBACK

20 d.b.

### DAMPING FACTOR

12



**RETAIL PRICE 33 Gns.**

Send S.A.E. for leaflet.

For operation on standard 200-250 v. 50 c.p.s. A.C. mains. 110/120 v. models available for export.

Trade and export enquiries invited.

**LINEAR PRODUCTS LTD.**  
 ELECTRON WORKS, ARMLEY, LEEDS

## A HIGHLY EFFICIENT 30 WATT GENERAL PURPOSE PUBLIC ADDRESS UNIT

With input mixing facilities and outputs for 3-7.5-15 and 330 ohms (100 volt line).

A special feature of the SUPER 30 is its high degree of stability, ensuring that the longest output leads can be used without fear of the usual troubles associated with instability.

Three high sensitivity standard Jack inputs with provision for high and low impedance microphones.

# OXLEY

TYPE 062

## SUB-MINIATURE 'BARB' INSULATORS

A new OXLEY Patented sub miniature insulator which is speedy to assemble and with outstanding physical characteristics:

The P.T.F.E. bush, which is supplied with the heavily silver Plated brass "barb" partly inserted, is located in an ordinary .062" dia. hole and the barbed spill is pressed firmly through the assembly, thus expanding the P.T.F.E. bush on the far side of the chassis and locking the complete assembly firmly in the chassis.

Working voltage 500 V.DC; Capacity less than .5 pF; Temperature range -55°C to +200°C; Resistance to pull in either direction 3 lbs; Chassis thickness = .22 24; SWG = .022 / .028" = 0.56 0.72 m m; Mounting hole dia. .062" = 1/16" = 1.58 m/m.

100 of these Insulators mounted, occupy only one square inch of chassis space.

**OXLEY DEVELOPMENTS CO., LTD.**

ULVERSTON : LANCASHIRE.  
 Telephone : ULVERSTON 2567

ERSIN

*Multicore*  
 SOLDER

The world-famous copper loaded alloy containing 5 cores of non-corrosive flux, that saves the soldering iron bit. Ersin Multicore Solder is also available in high tin quality alloys. 60/40 in 22 s.w.g. for printed circuits, transistors, etc.

### THE HANDY DISPENSER



Easy to find in the tool box—simple to use. Virtually a third hand for tricky soldering jobs. 12 feet 5 core 18 s.w.g. ERSIN MULTICORE SAVBIT alloy in a continuous coll used direct from free-standing dispenser. 2/6 each

## SAVBIT ALLOY saves wear on soldering iron bits

### SAVBIT SIZE 1 CARTON

Contains approximately 30 feet of 18 s.w.g. SAVBIT. It is also supplied in 14 s.w.g. and 16 s.w.g. Obtainable from radio and electrical stores.

5/- each



### BIB WIRE STRIPPER AND CUTTER

Strips insulation without nicking wire, cuts wire cleanly, adjustable to most thicknesses. Splits extruded plastic twin flex. 3/6 each



**MULTICORE SOLDERS LTD.**

MULTICORE WORKS · HEMEL HEMPSTEAD · HERTS. (BOXMOOR 3636)

# LASKY'S RADIO

## For the Finest Value and Service to the HOME CONSTRUCTOR AND THE ELECTRONICS ENTHUSIAST

We consider our construction parcels to be the finest value on the home constructor market. If on receipt you feel not competent to build the set, you may return it as received within 7 days, when the sum paid will be refunded less postage.

### TRANSISTOR PORTABLES



#### ★ LONG WAVEBAND COVERAGE IS NOW AVAILABLE FOR THE SKYROVER AND SKYROVER DE LUXE.

A simple additional circuit provides coverage of the 1100/1950M. band (including 1500 M. Light programme). This is in addition to all existing Medium and Short wavebands. All necessary components with construction data.

Only 10/- extra Post Free.

This conversion is suitable for both receivers that have already been constructed.

Data for each receiver: 2/6 extra. Refunded if you purchase the parcel. Four U2 batteries 3/4 extra. All components available separately.

#### THE SKYROVER RANGE

7 transistor and 2 diode superhet portables—covering full med. plus 6 SW Bands.

#### The SKYROVER Mk II.

(Illustrated). Now supplied with redesigned cabinet, edgewise controls. New colour tuning scale and cabinet in Sierra Tan.

Controls: Waveband Selector, Volume Control with on/off Switch, Tuning Control. In plastic cabinet, size 10 x 6 1/2 x 3 1/2 in. with metal trim and carrying handle.

Can now be built for **£8.19.6** P. & P. 5/- extra H.P. Terms: £1 deposit and 11 monthly payments of 16/6. Total H.P.P. £10.1s.6d.

#### The SKYROVER De Luxe

Tone Circuit is incorporated, with separate Tone Control in addition to Volume Control. Tuning Control and Waveband Selector. In a wood cabinet, size 11 1/4 x 6 1/2 x 3 1/2 in. covered with a washable material, with plastic trim and carrying handle. Also car aerial socket fitted.

Can now be built for **£10.19.6** P. & P. 5/- extra. H.P. Terms: 25/- deposit and 11 monthly payments of 20/-. Total H.P.P. £12.5s.

#### REALISTIC SEVEN

Fully tunable long and medium bands. Uses 7 Mullard Transistors; plus Diode OA70.

#### STAR features:

- 7 Transistor Superhet. ● 350 Milliwatt output 4in. high flux speaker. ● All components mounted on a single printed circuit board, size 5 1/2 in. x 5 1/2 in. in one complete assembly. ● Plastic cabinet, with carrying handle, size 7 in. x 10 in. x 3 1/2 in., in blue/grey. ● Easy to read dial. ● External socket for car aerial. ● I.F. frequency 470 Kc/s. ● Ferrite rod internal aerial. ● Operates from PP9 or similar battery. ● Full comprehensive data supplied with each Receiver. ● All coils and I.F.s etc., fully wound ready for immediate assembly. An outstanding Receiver.



Can be built for

**£5.19.6**

P. & P. 4/6.

#### REALISTIC SEVEN De Luxe

By popular request a De Luxe version of the well-known Realistic Seven now available. With the same electrical specification as standard model—PLUS A SUPERIOR WOOD CABINET IN CONTEMPORARY STYLING covered in attractive washable material, with super-chrome trim and carrying handle. Also a full vision circular dial, externally mounted to further enhance the pleasant styling. **ONLY £1 EXTRA**

Both models: Battery 3/9 extra. (All components available separately.) Data and instructions separately 2/6, refunded if you purchase parcel.



#### TWO SINCLAIR SUPER MINIATURES

**THE MICRO-6** Self-contained pocket radio. Size only 1 4/5 x 1 3/10 x 1/2 in. A marvel of modern miniaturisation—truly amazing performance. Without a doubt the most advanced transistor circuit ever offered to home constructors—yet may be built in an evening. Complete with earphone and detailed construction data. Can be built for only **59/6** All parts sold Mercury cell 1/11 extra (2 required) separately.

**THE SLIMLINE** The new amazing performance 2-transistor pocket radio size only 2 1/2 in. x 1 1/2 x 1 1/2 in. Micro alloy transistorised and printed circuit. Easy to assemble. **CAN BE BUILT FOR 49/6** All components available separately.

#### NEW! ANOTHER SINCLAIR SUPER MINIATURE

**THE X10** 10 watt power amplifier fitted with integrated pre-amplifier. Requires only 1 mV. for an output of 10 watts undistorted. Frequency response is flat 1 dB from 5 c/s. to 20 kc/s. Size only 6 x 3 x 1 1/2 in. Weight 5 oz. Built on printed circuit. Operates from 12 v. D.C. at 75 mA. quiescent. Circuit uses 7 M.A.T.s and 4 RF power transistors. **PRICE £5.19.6** Post Free

**AVAILABLE READY BUILT, TESTED AND GUARANTEED, £6.19.6** Post Free. 3 pots. for volume, Bass and Treble, 7/6 the 3 extra. Mains power pack if required, 54/-.

#### TRANSISTORS ALL BRAND NEW AND GUARANTEED

GET 81, GET 85, GET 86 2/6; 873A, 874P 3/6; OC45, OC71, OC81D 4/6; OC 44, OC 70, OC 76, OC 81 5/6; (match pair 10/6); AF 117, OC 75, OC 200 8/6; OC 42, OC 43, OC 73, OC 82D 7/6; OC 201, OC 204 15/-; OC 205, OC 206 19/6; OC 28 24/6.

#### TRANSFILTERS By BRUSH CRYSTAL CO. Available from stock.

TO—01B 465 kc/s. ± 2 kc/s. | TO—02D 470 kc/s. ± 1 kc/s. **6/6 EACH**  
TO—01D 470 kc/s. ± 2 kc/s. | TF—01B 465 kc/s. ± 2 kc/s.  
TO—02B 465 kc/s. ± 1 kc/s. | TF—01D 470 kc/s. ± 2 kc/s. P. & P. 6d.

### CONSTRUCTORS BARGAINS

#### The "Sixteen" Multirange METER KIT

This outstanding meter was featured by *Practical Wireless*, in the Jan. '64 issue. Lasky's are now able to offer the complete kit of parts as specified by the designer.

#### RANGE SPECIFICATION:

D.C. volts: 0-2.5-25-50-250-500 at 20,000 Ω/V.

A.C. volts: 0-25-50-250-500 at 1,000 Ω/V.

D.C. current: 0-50 μA, 0-2.5-50-250 mA.

Resistance: 0-2000 Ω, 0-200k Ω, 0-20 M Ω.

Basic movement: 40 μA f.s.d. moving coil. With universal shunt full scale deflection current is 50 μA.

Size/finish: Black plastic case—3 1/2 x 5 1/2 x 1 1/2 in.

Controls: 12 position range switch; separate slide switch for A.C. volts—D.C. ohms; ohms zero adjustment pot. meter; meter zero. External connections: Two 4 mm. sockets for test lead plugs.

Power requirements: One 15v. and one 1.5v. batts. Complete with all parts and full construction details.

**LASKY'S PRICE £5.19.6** P. & P. 5/-.



H.P. Terms: 21/- deposit and 5 monthly payments of 21/-. Data and circuit available separately, 2/6; refunded if all parts bought. Pair of batteries 2/- extra.

#### BUILD A HIGH QUALITY TAPE RECORDER

Using the famous Collaro "STUDIO" deck and MARTIN pre-assembled amplifiers 2- or 4-track models.

#### COLLARO STUDIO TAPE DECK.

Latest model 3 speed, 3 motors. Take 7in. reels. Fitted with half-track heads.

**LASKY'S PRICE £10/10/-**. New and Unused. Carr. & Pack. 7/6.

**COLLARO STUDIO TAPE DECK.** As above but fitted with the latest quarter-track heads. **LASKY'S PRICE £13/19/6**. Carr. & Pack. 7/6.

**MARTIN TAPE RECORDER AMPS.** Designed for use with Collaro Studio Tape Deck. In sub-assemblies for immediate installation. 6-valve circuit. Comprehensive instructions make final assembly as simple as possible. Everything supplied including valves, etc. Monitoring facilities. 3-ohm output, speed equalising, etc. For 200-250 v. A.C. mains.

**PRICES** 1-track Model £11/11/-. 1-track Model £12/12/-. P. & P. 2/6. Portable carrying case designed to take the Collaro Studio Tape Deck and the Martin Tape Amplifier. Fitted with 9 x 5in. speaker. Price complete with speaker £5/5/- P. & P. 5/-.

#### FROM PRE-AMP TO 20 WATT HI-FI STEREO ASSEMBLY AVAILABLE FROM STOCK

Using specially developed circuits, the very latest transistors and printed circuits—these kits are all fully checked and tested before leaving the factory. Although the kit are basically designed for use together the pre-amplifier and mixer stages may be used to great advantage with existing valve or transistor equipment.

**KIT 1.** 5-stage Matching Input Selector Unit..... **LASKY'S PRICE 47/6**

**KIT 2.** Pre-amplifier with volume control..... **LASKY'S PRICE 37/6.**

**KIT 3.** 3-Channel Mixer with plug-in adaptors for individually matching each circuit. Adaptors 8/6 each..... **LASKY'S PRICE 79/6.**

**KIT 4.** Pre-amplifier with tone/volume control stages..... **LASKY'S PRICE 62/6.**

**KIT 5.** 10 and 3 watt Main Amplifier..... **LASKY'S PRICE £5/12/6.**

**KIT 6.** Power supply converter unit..... **LASKY'S PRICE 52/6.**

**KIT 7.** 15 ohm version of Kit 5..... **LASKY'S PRICE £6/12/6.**

**KIT 8.** Power supply for Kit 7..... **LASKY'S PRICE £2/15/-.**

### SPECIAL INTEREST ITEMS!

#### TEST METER ADAPTOR

Type P.E. 220—this is a fully transistorised device which enables any 50 microamp D.C. Multimeter to be used in place of a valve volt meter. On the 1 V. range an impedance of 1 megohm is offered which increases on the 1000 V. range to 100 megohms. 7 ranges: 1 to 1000 volts. Designed for immediate connection to Avo 7, 8 and similar size meters but quite suitable for use with any other 50 microamp meter. Size 6 x 6 x 5 in. New and boxed. List Price 7 Gns.

**LASKY'S PRICE 39/6** P. & P. 2/6. Set of batteries 7/6 extra.

#### VEROBOARD — NOW IN STOCK

A really remarkable time saver in setting out complicated experimental circuits. Veroboard is a high grade laminated board with copper strips bonded to it and pierced with a regular matrix of holes. Ideal for producing single items. As featured in "Practical Electronics" February '65 issue.

Boards	Accessories
42/1503 2 1/2 x 5 in. .... 3/8	Terminal pins — pkt. of 36 ..... 3/3
43/1504 2 1/2 x 3 1/2 in. .... 3/-	Spot face cutter tool ..... 9/-
45/1507 3 1/2 x 5 in. .... 5/2	Pin inserting tool ..... 9/9
46/1508 3 1/2 x 3 1/2 in. .... 3/8	
44/1505 3 1/2 x 17 in. .... 13/6	

P. & P. 6d. per item extra.

#### THE "HARROW" POWER PACK

Battery eliminator for portable radios, etc. Converts your battery radio to A.C. mains. Replaces 4 1/2 v., 6 v. and 9 v. batts. Size only 3in. x 2 1/2 in. x 2 1/2 in. State voltage required when ordering. **LASKY'S PRICE 29/6** P. & P.

207 EDWARE ROAD, LONDON, W.2.

Near Praed St. PADDINGTON 3271/2

BOTH OPEN ALL DAY SAT. Early Closing Thurs.

33 TOTTENHAM COURT ROAD, W.1.

Nearest Stn., Goodge St. MUSEUM 2605

Mail Orders to Dept. P.E., 207 Edware Rd., W.2.

152/3 FLEET STREET, LONDON, E.C.4.

Telephone: FLEET STREET 2833

OPEN ALL DAY THURSDAY. Early Closing Sat.

**LASKY'S FOR SPEEDY MAIL ORDER SERVICE**

**FOR — IMMEDIATE — DESPATCH — PHONE — US — TODAY**

**BUILD YOUR RECORD PLAYER**

4 Speed Antochange 2-tone Cabinets 17x15x8 1/2 in. High flux loudspeaker and 3 watt 2-valve 2 stage amplifier ready built. Quality output. Volume and Tone controls. All items fit together perfectly. Special instructions enable assembly in 30 minutes, only 5 wires to join. 12 months' written guarantee.



**AUTOCHANGE KITS**

Complete—as above.  
 B.S.R. Monarch £10/19/6 P.P. 5/-  
 Garrard Autoslim £11/19/6 P.P. 5/-  
**ALL AVAILABLE SEPARATELY**  
 Cabinet with board 14x13in. £3/9/6 P.P. 3/6  
 Amplifier with speaker £3/17/6 P.P. 3/6  
**AUTOCHANGERS (Stereo Mono 15/- extra)**  
 B.S.R. UA25 Superslim £5/19/6 P.P. 3/6  
 Garrard Autoslim Mono £6/10/- P.P. 3/6  
**SINGLE PLAYERS**  
 Garrard SRP 10 auto. stop/start £5/5/- P.P. 3/6  
 E.M.I. Latest model auto stop £4/15/- P.P. 3/6

**Q MAX CHASSIS CUTTER**

Complete: a die, a punch, an Allen screw and key.  
 1/2 in. 14/6 1 1/8 in. 18/- 1 1/2 in. 22/6  
 3/4 in. 14/6 1 1/4 in. 18/- 2 in. 34/3  
 7/8 in. 15/6 1 1/2 in. 18/6 2 1/2 in. 37/9  
 1 in. 15/9 1 3/4 in. 20/- 2 3/4 in. 44/9  
 1 in. 18/- 1 1/2 in. 20/6 1 in. sq. 31/6

**CRYSTAL MIKE INSERTS. High O/P 6/6**  
 ACOS MIKE INSERT 1 1/2 x 3/4 in. 8/6  
 ACOS STICK MIKE 39-1 35/-  
 T.S.L. DE LUXE STICK MIKE 25/-  
 TELEPHONE CONTACT MIKE 10/6  
 GUITAR XTAL MIKE 15/6  
**PROFESSIONAL MAGNETIC GUITAR MIKE with Vol. and Tone Controls 59/6**  
 Moving Coil Mike 90/-, Floor Stand 57/-  
 TANNOY CARBON MIKE 5/6

**FULL WAVE BRIDGE SELENIUM RECTIFIERS:**  
 2, 6 or 12 v. outputs, 1 1/2 amp., 8/9; 2 a., 11/3; 4 a., 17/6.  
**CHARGER TRANSFORMERS.** Tapped input 200/250 v. for charging at 2, 6 or 12 v., 1 1/2 amp., 15/8; 2 amp., 17/8; 4 amp., 22/6. Circuit included. Amp meter 5 amp., 10/6.

**MINIATURE PANEL METERS 2%**  
 Size 1 1/2 in. sq. Precision jewelled bearings, 0.1 mA. 27/6; 0.5 mA. 27/6; 0-300 v. 27/6; 0-50 uA 39/6; 0-500 uA 32/6. "S" meter 35/-

**MOVING COIL MULTIMETER TK20A.** 0-1,000 v. A.C./D.C. ohms. 0 to 100 K., 0-150 mA. Pocket size 2in. scale, 49/6.

**TRANSISTOR 4 CHANNEL MIXER** with 4 separate input-output controls, 59/6

**VALVE HOLDERS.** EA50 6d. MOULDED Int. Oct. or Mazda Oct. 6d.; B7G, B8A, B8G, B9A, 9d.; B7G with can 1/8. B9A with can 1/9. Ceramic Oct., EF50, B7G, B9A, 1/- . Valve base plugs B7G, B9A, Int. Oct., 2/3.

**1965 RADIOGRAM CHASSIS**

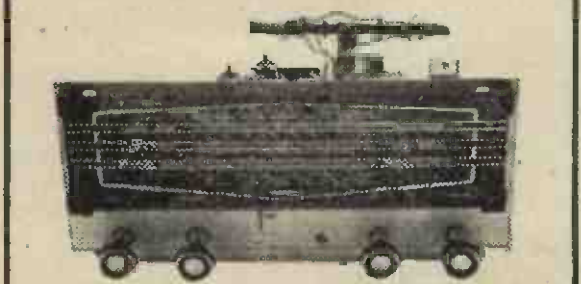

Three Wavebands Long., Med., Short. Five Valves: ECH81, EF89, EBC81, EL84, EZ80, 12-month guarantee. A.C. 200-250 v. Ferrite Aerial A.V.C. Negative Feedback. 5 watts 3 ohm. Chassis 13 1/2 in. x 7 in. high x 5 in. deep. Glass dial size 13 in. x 4 in. horizontal wording. Two Pilot Lamps. Four Knobs. Aligned calibrated. Chassis isolated from mains.  
**BRAND NEW £9.15.6** Carr. 4/8.  
 ARMSTRONG 'GRAM CHASSIS V.H.F. MODEL. 127M. MED. and F.M. £26.10, Stereo £37.18.

**NEW ELECTROLYTICS FAMOUS MAKES**

TUBULAR		TUBULAR		CAN TYPES	
1/350 v. . . . . 2/-	100/25 v. . . . . 2/-	8/600 v. . . . . 9/-	2/350 v. . . . . 2/6	16/800 v. . . . . 12/-	
4/350 v. . . . . 2/3	250/25 v. . . . . 2/6	16+16/500 v. 7/6	8/450 v. . . . . 2/3	32+32/350 v. 5/6	
16/450 v. . . . . 3/-	1,000/12 v. 3/-	32+32/450 v. 6/-	8+8/450 v. 3/6	50+50/350 v. 7/-	
32/450 v. . . . . 3/9	8+16/450 v. 3/9	64+120/350 v. 11/6	16+16/450 v. 4/3	100+200/275 v. 12/6	
50/50 v. . . . . 2/-	32+32/350 v. 4/6				

**PAPER CONDENSERS.** 0.001mfd., 7kV., 8/8; 20kV., 10/8; 0.1mfd., 7 kV., 9/6; Tubular 500 v. 0.001 to 0.05. 9d.; 0.1 1/-; 0.25 1/6; 0.1/350 v. 9d.; 0.5/350 v. 1/9; 0.01/2,000 v. 2/6; 0.05/2,000 v. 3/6. **CERAMIC.** 500 v. 1 pF. to 0.01 mfd., 9d. Disc Ceramics 1/- each. Pulse 100 pF., etc., 12 kV., 2/6. **SILVER MICA.** (plus or minus 1 pF.), 2.2 to 47 pF., 1/-; ditto 1% 50 to 815 pF., 1/-; 1,000 to 5,000 pF., 1/9. **TWIN GANG.** 208 pF+176 pF., 10/8; 365 pF. miniature 10/-; 500 pF. standard with trimmers, 9/-; midget with trimmers, 9/-; 500 pF. slow motion, standard 9/-; small 3-gang 500 pF. 17/8. Single "0" 365 pF. 7/6. **SHORT WAVE.** Single 10 pF., 25 pF., 50 pF., 75 pF., 100 pF., 160 pF., 5/8 each. Couplers 9d. each. **TUNING AND REACTION.** 100 pF., 300 pF., 500 pF., 3/8 each, solid dielectric. Trimmer with knob 1000pF., 2/- . **TRIMMERS.** Compression ceramic 30, 50, 70 pF., 9d.; 100 pF., 150 pF., 1/3; 250 pF., 1/6; 600 pF., 750 pF., 1/9.

**MAINS TRANSFORMERS**

STANDARD 250-0-250, 80 mA. 6.3 v. 3.5 a., tapped 4 v. 4 a. Rectifier 6.3 v. 1 a. tapped 5 v. Or 4 v. 2 a. . . . . 22/6  
 Ditto 350-0-350 . . . . . 29/6  
 MULLARDO "51" MAINS TRANS. TO SPEC. . . . . 33/6  
 300-0-300 120 mA., 6.3 v. CT 4a. 0, 5, 6.3 v. 2 a. . . . . 10/8  
 MINIATURE 200 v. 20 mA., 6.3 v. 1 a. . . . . 15/6  
 MIDGET 220 v. 45 mA., 6.3 v. 2 a. . . . . 17/6  
 SMALL, 250-0-250 v. 45 mA., 6.3 v. 2 a. . . . . 17/6  
 STANDARD 250-0-250 85 mA., 6.3 v. 3.5 a. . . . . 17/6  
 HEATER TRANS. 6.3 v. 1 1/2 a. . . . . 7/6 4 a. . . . . 10/6  
 Ditto tapped sec. 1. 4 v., 2, 3, 4, 5, 6.3 v. 1 1/2 amp. . . . . 8/6  
**GENERAL PURPOSE LOW VOLTAGE.** Outputs 3, 4, 5, 6, 8, 9, 10, 12, 15, 18, 24 and 30 v. at 2 a. . . . . 22/6  
 AUTO TRANS. 150 w. 0, 115 v. 200, 230, 250 v. . . . . 22/6  
 AUTO TRANS. 500 w. 0, 115, 200, 230, 250 v. . . . . 82/6

**Special Offer of Manufacturers' Surplus**

**2 VALVE GRAM AMPLIFIERS**  
 Valves: UY85 Rectifier and UCL82 Triode/Pentode giving 3 1/2 watts output. Chassis size (inc. valves) 5 x 5 1/2 x 2 in. deep. New and Tested complete with valves, 3 ohm output transformer and knobs for tone and volume on/off controls. **ONLY 37/6 P. & P. 2/6**  
 Complete ready for use 200 250 v. A.C. or can be used with 80 v. motor tap or 160 v. motor.

**"THE POWER MITE" 45/-**

PM9 Mains Unit 8 volt for Transistor Radios. Same size as P.P.9. Mains Input 200-250 A.C.  
**WEYRAD P50 — Transistor Coils**  
 Ferrite aerial—RA2W 12/6. Osc. P50/1AC 5/4. 1st and 2nd I.F. P50/2CC 5/7 each. 3rd I.F. P50/3CC 6/-. Spare Cores, 6d. Driver Trans—LFDT4 9/6. Printed Circuit 9/6. 35 ohm Speakers, 5 in., 17/8. 6 x 4 in., 21/-. J.B. Tuning Gang 10/6. Booklet 2/-.

**NEW MULLARD TRANSISTORS**

OC71 6/-; OC72 7/8; OC81D 7/8; OC81 7/8; AF115 10/6; AF114 11/-; OC44 8/-; OC45 8/-; OC171 9/-; OC170 8/8; AF117 9/8. OC26 12/6; Transistor Holders 1/3. Sub Miniature Condensers. 0.1 mFd., 30 v. 1/3; 1, 2, 4, 5, 8, 16, 25, 30, 50, 100 mFd., 15 volt 2/8. Diode OA81 3/-.

**Volume Controls 80 Ohm Coax**

Long spindles. Midget Size 5 K. ohms to 2 Meg. LOG or LIN. L/S 3/-. D.P. 4/6. Stereo L/S 10/8. D.P. 14/6. Linear or Log Tracks. Semi-air spaced 6d. yd. 40 yd. 17/8. 60 yd. 25/- . Low loss 5dB. per 100ft. at 500 mc/s. Ideal 625 lines 1/8 yd. **COAXIAL PLUG 1/-.** PANEL SOCKETS 1/-. LINE SOCKETS 2/-. OUTLET BOXES, SURFACE OR FLUSH 4/-. BALANCED TWIN FEEDERS 6d. yd., 80 or 300 ohms. TWIN SCREENED FEEDER 1/- yd., 80 ohms. TELESCOPIC CHROME AERIALS. 12in. extends to 33in. 6/8 each. CAR AERIAL PLUGS 1/8. Sockets 1/3.

**THE "INSTANT" BULK TAPE ERASER AND RECORDING HEAD DEMAGNETIZER**

Leaflet S.A.E. 200/250 v. A.C. **35/-**

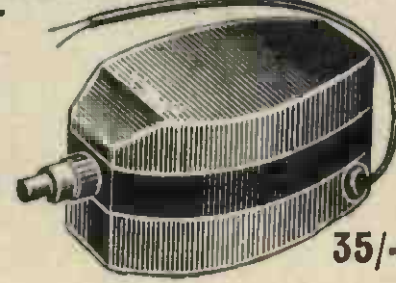

**12" GUITAR HEAVY DUTY 25w. LIFETIME GUARANTEE, 5 gns.**

**FOR BASS, LEAD AND RHYTHM GUITARS**

**BAKERS 'Selhurst' 15 OHM VOICE COIL 20-10,000 cps BASS RESONANCE 80 cps GENUINE MUSICAL INSTRUMENT LOUDSPEAKER**



**HI FI AND PUBLIC ADDRESS MODELS**

12in. STANDARD HEAVY DUTY 20 w. 7 gns. More powerful magnet 14,000 lines, special suspension. 40-14,500 c.p.s. Recommended wherever a high standard of reproduction is desired.  
 15in. AUDITORIUM MODEL 35 w. 18 gns. Improved magnet alcomax with heavy plated assembly, 17,000 lines, 20-12,000 c.p.s. Heat proofed Coil Former. Ideal for Electric Guitars. Repairs Service for Bakers and R.T.C. Loudspeakers.

**LOUDSPEAKERS. 3 OHM FAMOUS MAKES.** 5in., 7x4in., 15/8 ea.; 8in. 17/8; 6 1/2 in. 16/8; 10in., 12in. 30/- ea. (15 ohms 35/-); 10x6in. 22/6, 9x6in. 21/-, 8x3in. 17/8. **WAVE-CHANGE SWITCHES** with long spindles 3/8 each. 2p. way, or 2 p. 8-way, or 3 p. 4-way, or 1 p. 12-way; 4p. 2-way, or 4 p. 3-way, 6/8; 8 p. 4-way, 2 wafers. Wavechange "MAKITS" Wafers available; 1 p. 12-way, 2 p. 6-way, 3 p. 4-way, 4 p. 3-way, 6 p. 2-way. Prices include click spindles, adjustable stops, 1 wafer, 8/8; 2 wafers, 12/8; 3 wafers, 16/-. Extra wafers up to 12, 3/8 each. **TOGGLE SWITCHES, s.p., 2/-; d.p. 3/8; d.p.d.t., 4/-.**

**BOOKS (Please Add Postage)**

"W.W." Radio Valve Data . . . . . 7/6  
 High Fidelity Speaker Enclosures . . . 5/-  
 At a Glance Valves, CRT Equivalents 3/6  
 TV Fault Finding . . . . . 6/-  
 Mullard Audio Amplifier Manual . . . 8/6  
 Radio Valve Guide, Books 1, 2, 3 or 4 ea. 5/-  
 Practical Radio Inside Out . . . . . 3/6  
 Master Colour Code . . . . . 1/6  
 Coil Design and Construction Manual 5/-  
 International Radio Stations List . . . 2/6  
 Boys' Book of Crystal Sets . . . . . 2/6  
 Stroboscopic Disc 33, 45, 78 r.p.m. . . 1/-  
 How to Receive Foreign T.V. . . . . 5/-

**JACKS.** Standard open-circuit 2/6, closed-circuit 4/6. Grundig type 3-pin 1/3; Grundig Lead Tube 3/6. **PHONO PLUGS 1/-.** Socket 1/-. Banana Plugs 1/-. Sockets 1/-. **JACK PLUGS STANDARD.** Screened 3/-. Grundig 3-pin 3/8. **BULGIN NON-REV PLUGS AND SOCKETS.** P74 2-pin 4/3; P73 3-pin 4/8; P104 6-pin 6/8; P488 6-pin 12/6; P360 4/- . **RESISTORS.** Preferred values, 10 ohms to 10 meg. 1/2 w., 1 w., 1 w., 20% 4d.; 1 1/2 w. 8d.; 2 w. 1/-; 1/2 w. 10% 6d. **HIGH STABILITY.** 1/2 w. 1% 2/-. Preferred values. 10 ohms to 10 meg. Ditto 5%, 10 ohms to 22 meg., 9d. 5 watt } WIRE-WOUND RESISTORS { 1/6  
 10 watt } 10 ohms 6,800 ohms { 2/-  
 15 watt } 10K, 15K, 20K, 25K, 10W. { 3/-

**MAINS DROPPERS.** Midget. With sliders. 0.3 a., 1K., 0.2 a., 1.2 K., 0.15 a., 1.5 K., 0.1 a., 2 K., 6/- each. **LINE CORD** 100 ohms ft. 3-way 1/- ft. **WIRE-WOUND Pots. 3 WATT Pre-set Min. T.V. STANDARD SIZE POTS.** Type. All values 10 ohms LONG SPINDLE VALUES to 25 K., 3/- ea.; 30 K. 4/-; 50 OHMS to 50 K., 6/8; Carbon 30 K. to 2 meg., 3/-; 100 K. 7/8. **SPEAKER-FRET.** Tygan various colours, 52in. wide from 10/-ft.; 26in. wide from 5/- ft. Samples, large, S.A.E. **EXPANDED METAL.** Gold 12x12in. 6/-.

**ARDENTE TRANSISTOR TRANSFORMERS**  
 D3035, 7.3 CT : 1 Push Pull to 3 ohms for OC72, OC81 . . 11/-  
 D3034, 1.75 : 1 CT. Push Pull Driver for OC72, OC81 . . 11/-  
 D3058, 11.5 : 1 Output to 3 ohms for OC72, OC81 . . 11/-  
 D239, 4.5 : 1 Driver; D240, 8.5 : 1 Driver . . . . . ea. 11/8  
**ARDENTE TRANSISTOR POT. 5 K. switched VC1545 5/3**  
 Anti-Parasitic beads . . . . . doz. 3/6  
**BLANK ALUMINIUM CHASSIS.** 18 s.w.g. 4 sides, riveted corners, lattice fixing holes, 2 1/2 in. sides, 7x4in., 5/8; 9x7in., 6/8; 11x3in. 8/8; 11x7in. 7/6; 13x9in. 9/8; 14x11in. 12/8; 15x14in., 15/- . **ALUMINIUM PANELS** 18 s.w.g. 12x12in. 5/8; 14x9in. 4/8; 12x8in. 3/8; 10x7in. 2/9; 8x6in. 2/-; 6x4in. 1/6.

**B.T.H. TAPE MOTORS 115 v A.C. 28 w. 12/6 pair, for 200/250 v. (in series)**

**RETURN OF POST DESPATCH (Export. Send remittance and extra postage, no C.O.D.) CALLERS WELCOME**

**RADIO COMPONENT SPECIALISTS**

Written guarantee with every purchase. Buses 133, 68 pass door. S.R. Stn. Selhurst. P.P. Charge 1/-, Full List 1/-, C.O.D. 2/- extra.

# The NEW Stern-Clyne ELECTRONIC CONCERT ORGAN TO BUILD YOURSELF

## DESIGNED —

- For the Electronic amateur seeking the most fascinating project.
- For the discriminating organist seeking an instrument which DOES sound like a pipe organ.

## NEW —

- Constructional methods introducing "sectional complete instrument" building.
- Extended range of tone colours. Without unrealistic "Gimmick" effects.

**THE MOST COMPREHENSIVE KIT OF PARTS AVAILABLE IN THIS COUNTRY**

**START BUILDING FOR AS LITTLE AS  
£75.15.0 approx. (H.P. Terms Available)**

Send 2/6 for data and information booklet (credited on initial purchase) to: **Electronic Organ Dept., 162 Holloway Road, London, N.7.**

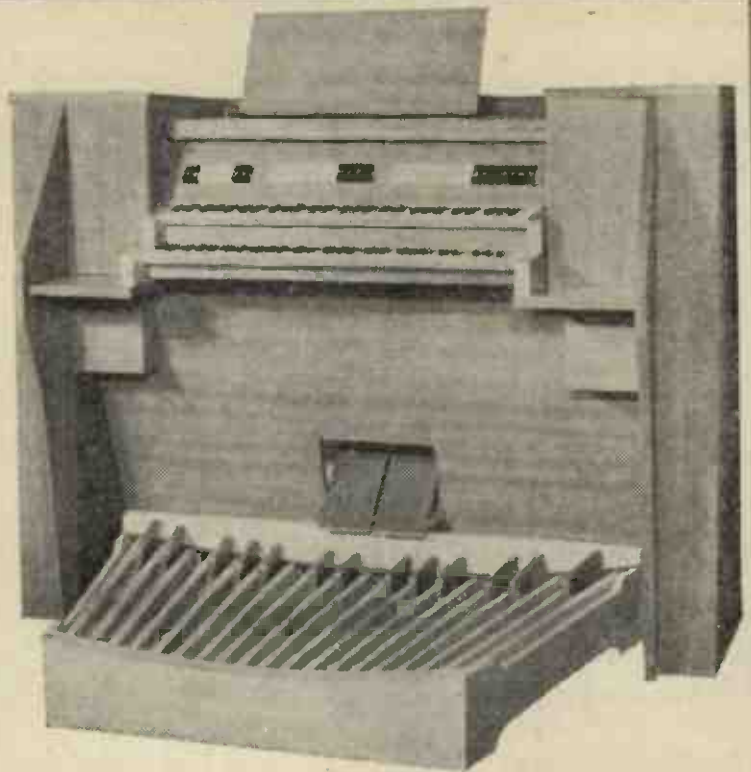

VISIT US AT  
162 HOLLOWAY ROAD, LONDON, N.7  
and hear this fabulous new Electronic Concert  
Organ demonstrated.

# STERN-CLYNE

GREAT BRITAIN'S GREATEST ELECTRONIC HOBBIES ORGANISATION

HERE'S WHY THOUSANDS OF  
ELECTRONICS ENTHUSIASTS  
BUY WITH CONFIDENCE  
FROM STERN-CLYNE —

- A wide range of exclusive equipment available including our own speciality — MULLARD DESIGNS — for the home constructor or ready assembled.
- The finest selection of Hi-Fi and Audio equipment by all leading manufacturers.
- A comprehensive range of electronic components for the build it yourself enthusiast available at all branches.
- Retail shops, showrooms and demonstration rooms throughout London and the provinces all carry extensive stocks.
- Finest Mail Order Service—geared to give prompt and efficient attention.
- Hire Purchase facilities available on orders of £11 10. 0 and over.
- Hi-Fi advisory service to help you in choosing the right equipment.
- After sales service — complete satisfaction guaranteed.

VISIT YOUR NEAREST  
STERN-CLYNE ELECTRONICS CENTRE

### LONDON

18 Tottenham Court Rd., W.1. MUSEum 5929-0095. Half Day Sat.  
23 Tottenham Court Rd., W.1. MUSEum 3451-2. Half Day Thurs.  
309 Edgware Rd., W.2. PADdington 6963. Half Day Thurs.  
109 Fleet St., E.C.4. FLEet St. 5812-3. Half Day Sat.  
162 Holloway Road, N.7. NORth 7941. Half Day Thurs.  
9 Camberwell Church St., S.E.5. RODney 2875. Half Day Thurs.

### BRISTOL

26 Merchant Street, Bristol 1. Bristol 20261.  
Now open 6 days a week.

### CROYDON

12 Suffolk House, George St. MUNicipal 3250. Half Day Wed.

### LIVERPOOL

52 Lord Street, Liverpool. Royal 7450. Open 6 days a week.

### MANCHESTER

20-22 Withy Grove, Manchester 4. BLAckfriars 5379-5246.  
Open 6 days a week.

### SHEFFIELD

125 The Moor, Sheffield. Sheffield 29993. Half Day Thurs.

### MAIL ORDERS AND ENQUIRIES TO:

Dept. P.E., 3-5 Eden Grove, Holloway, London, N.7. NORth 8161-5.

# CLEARANCE of COMPONENTS

at GREATLY REDUCED PRICES!

Here is your once-a-year chance! We must clear these lines to make way for new stocks. On the left-hand side we list the quantity available, in case you wish to make an offer for the lot. Call in or write . . . TO-DAY!

If ordering by post PLEASE INCLUDE 2/- EXTRA TO COVER POSTAGE & PACKING.

Quantity		Each
<b>CO-AX PLUGS AND SOCKETS</b>		
200	Films & Equipment co-ax Plugs	1/-
40	Films & Equipment co-ax Sockets...	2/6
<b>CHOKES</b>		
100	Heavy Duty Suppressor Chokes	1/-
<b>CERAMIC COIL FORMERS</b>		
50	1½" x ½", with fixing lugs	1/-
<b>CONDENSERS (ELECTROLYTIC) SINGLES</b>		
100	500 Mf. 25V. T.C.C. 2½" x 1½"	1/6
30	300 Mf. 25V. T.C.C. 2" x 1"	1/9
100	250 Mf. 50V. T.C.C. 2½" x 1½"	1/6
20	250 Mf. 50V. T.C.C. 2" x 1"	1/6
30	100 Mf. 50V. T.C.C. 1½" x 1"	2/-
40	32 Mf. 150V. T.C.C. 1½" x 1"	1/6
20	25 Mf. 50V. T.C.C. 1½" x 1"	1/-
200	16 Mf. 375V. T.C.C. 4½" x 1½"	4 for 2/-
200	16 Mf. 350V. DUBILIER 2" x 1"	4 for 2/-
50	8 Mf. 450V. T.C.C. 1½" x 1"	1/-
24	4 Mf. 450V. T.C.C. 1½" x 1"	1/-
<b>CONDENSERS (ELECTROLYTIC) DOUBLES</b>		
10	8 x 8 475V. SPRAGUE (Single hole fixing)	2/-
250	16 x 16 300V. T.C.C. 2½" x 1"	1/6
<b>CONDENSERS (NON-ELECTROLYTIC)</b>		
100	4 Mf. 600V. DUBILIER 4½" x 2 x 1½"	4/6
VISCONOL TYPE		
300	2 Mf. 800V. DUBILIER 4½" x 2 x 1½"	3/6
VISCONOL TYPE		
200	2 Mf. 600V. DUBILIER 2½" x 1½" x 1½"	2/6
300	2 Mf. 500V. DUBILIER 2½" x 1½" x 1"	1/6
300	2 Mf. 500V. WEGO 2½" x 1½" x 1"	1/-
50	.01 Mf. 400V. HUNTS W97	1/-
<b>CONDENSERS (DISC CERAMICS)</b>		
250	5000 Pf. ERIE	12 for 3/-
<b>CONDENSERS (HIGH VOLTAGE CERAMIC)</b>		
20	3 Pf. 4KV. working	1/6
60	1000 Pf. 3KV. working	2/6
50	200 Pf. 10KV. working	4/-
<b>CONDENSERS (TUNING)</b>		
20	3 gangs 500 Pf. (each section)	5/6
20	3 gangs 350 Pf. (each section)	5/6
10	2 gangs AM/FM 500 Pf. and 10 Pf. (each section)	3/6
24	2 gangs 50 Pf. (each section)	4/6
3	Single gang 400 Pf.	3/6
80	Single gang 160 Pf. Eddystone S.W. Condenser	2/6
24	Single gang 50 Pf.	3/6
80	Single gang 20 Pf. Eddystone S.W. Condenser	2/6
50	Single gang 20 Pf.	1/6

Quantity		Each
<b>CONDENSERS (TRIMMING AIR DIELECTRIC)</b>		
500	100 Pf. Jackson type	3 for 2/-
50	30 Pf. Polar (spindle ½" long)	1/6
50	20 Pf. Jackson type	1/6
<b>CONDENSERS (TRIMMING POSTAGE STAMP TYPE)</b>		
200	300 Pf. + 1000 Pf.	6 for 2/6
500	50 Pf. + 50 Pf. + 50 Pf. + 50 Pf. + 50 Pf.	1/-
<b>DIODES</b>		
60	HIGH QUALITY. Suitable F.M.	1/6
<b>METERS</b>		
34	40amp. (10 ma. without shunt) 2½" scale	19/6
20	500 Micro-amp 2½" scale marked 0-15 and 0-600	15/-
<b>MICROPHONE INSERTS</b>		
250	Carbon granule inserts	4 for 2/-
<b>MISCELLANEOUS</b>		
6	Miniature Electric Motors	2/6
1	Scanning Coll. type WB/108	5/-
2	Jason Audio-Attenuator Ready Built (List £8)	£4
1	Jason Audio-Attenuator Kit (List £5.5)	£3
14	Deaf Aid type Earphones	2/6
10	Gram Escutcheons. Speaker grille and hole either end for controls...	2/6
12	Grundig Leads with Jack Plug	3/6
36	Handles, Brass, 4"	2/-
10	Handles, Metal, covered in grey plastic 1½"	1/-
30	I.F. Transformers, 10 M/c	2/6
1	Kit G.E.C. Lite Writer (for Children)	12/6
1	Kit G.E.C. Alarm System (for Children)	12/6
100	Knobs, Television, Marked "FOCUS, BRILLIANCE, BRIGHTNESS, CONTRAST". Fit ½" spindle	Set of 4 1/-
100	Necked knob with 1½" extension. Marked "Volume, on/off". Fit ½" spindle. Spring clip fixing	1/-
50	Panel Mounting Neon lamps complete with G.E.C. tuneon bulb and suitable resistance for mains use	2/-
24	High Voltage Lead-throughs 1½" x ½", fixing disc 1½"	2/-
<b>POTENTIOMETERS</b>		
390	2 M.ohm Pre-sets	6 for 4/6
32	Bank of 4 Pre-sets. 1 Meg. 220K, 220K, 270K per bank	2/6
<b>RELAYS</b>		
60	Siemens high speed change-over relays, 1000 ohms (500 ohms each coil)	per pair 15/-
<b>RESISTORS</b>		
700	1 M.ohm. Wire wound 1% non-inductive. Surprise your friends, show them a million ohm wire-wound resistor, size 1" x ½". Surprise us too by buying one!	6d.
<b>SWITCHES</b>		
50	Toggle Switches D.P.D.T. 230V 3 Amp	2/-
50	2 Pole 4 way Ceramic	3/6
50	4 Pole 4 way Ceramic	4/6
<b>TRANSFORMERS</b>		
10	Modulation 1: 1.1 Gardiners. Very heavy duty	10/-
250	Output Transformers 7K to 3 ohms suitable ECL86. Made to high Admiralty Specification. Make a cheap Stereo outfit	2 for 7/6
2	Frame Output Transformer for Magnavox and Supervisor	5/-
<b>VALVES</b>		
50	EF85 Mullard Valves. Brand new	5/-
12	EM80 Mullard Valves. Brand new	5/-
70	EF92 Mullard Valves. Brand new	5/-
200	TT11 Valves. Brand new	2/6
<b>VIBRATORS</b>		
12	24 volt. Non synch.	2/6
<b>VOLTAGE ADJUSTMENT PANELS</b>		
50	Phillips type Rotary Adjusters marked 180, 200, 220, 240	1/-

To avoid delay make sure you add the extra 2/- for postage & packing.

Have you an up-to-date copy of the famous Home Radio Components Catalogue? It is a MUST for all constructors. Send 6/- (5/- + 1/- post and packing) and your copy will be sent by return post.

HOME RADIO LTD., DEPT. P.E., 187 LONDON ROAD, MITCHAM, SURREY. Phone: MITcham 3282



## INITIAL REPORT

THE publication of this our sixth issue might well provide a suitable occasion for reporting briefly on the general reaction from readers following our debut five months ago, and for discussing (again, briefly) progress made to date.

During this period we have received a steady stream of correspondence. While this represents but a small proportion of our present day readership—which has already reached an impressive figure—it must without doubt constitute a fair cross section of the whole.

★ ★ ★

From its very first appearance our magazine has met with considerable approval and we are delighted to have gained such a broadly based readership; for on the evidence of letters received, it embraces a wide range of age, experience and knowledge; it includes amateurs from all walks of life and professional electronics engineers.

We are naturally gratified and encouraged by this response and for the emphatic manner in which it has confirmed our own belief that keen interest in electronics exists among a large section of the technically minded public. To have provided something that was (as subsequently revealed) quite definitely needed is a cause for some satisfaction, naturally enough. But we cannot be complacent—indeed this very word has no place in the vocabulary of electronics.

★ ★ ★

Many useful and interesting ideas have been put forward by some of our correspondents and all of these will be considered as we endeavour to make further improvements in our contents and style of presentation.

We have had our critics too. Regrettably there have been a few occasions that warranted the admonishment received. Such pitfalls as these we shall make strenuous efforts to avoid in future. But as the saying goes—we are, after all, only human!

★ ★ ★

We think it will be generally agreed that in these few months under review we have already given some good indication of the possibilities offered by electronics. The constructional projects described so far represent, of course, only a small number of the infinite variety of devices that the amateur can build for himself or his friends.

The very variety of possible projects makes electronics a widely attractive hobby—but also presents us with certain problems of selection. However, by judicious choice of subjects it is hoped to provide the widest coverage of different specialised interests in the shortest period of time possible.

## THIS MONTH

### CONSTRUCTIONAL PROJECTS

PICK-UP AMPLIFIER AND EQUALISER	402
IMPEDANCE MATCHING UNIT	405
PULSE COUNTER	407
INEXPENSIVE OSCILLOSCOPE	411
MAGIC BOXES	428
AUDIO AMPLIFIER	435
MULTIVIBRATOR	438
AUDIO OSCILLATOR	440

### SPECIAL SERIES

SEMICONDUCTORS—3	419
BUILDING BLOCKS—I	422
BEGINNERS START HERE—6	432

### GENERAL FEATURES

INTRODUCTION TO LAMINATED WIRING BOARD	400
---	-----

### NEWS AND COMMENT

EDITORIAL	399
DETACHED PARTICLES	427
ELECTRONORAMA	430
THE 73 PAGE	434
NEWS BRIEFS	442
COLOUR TV SURVEY	446
NEW PRODUCTS	449
READOUT	453

*Our May issue will be published on  
Thursday, April 15*

# INTRODUCTION....



**1**



**4**

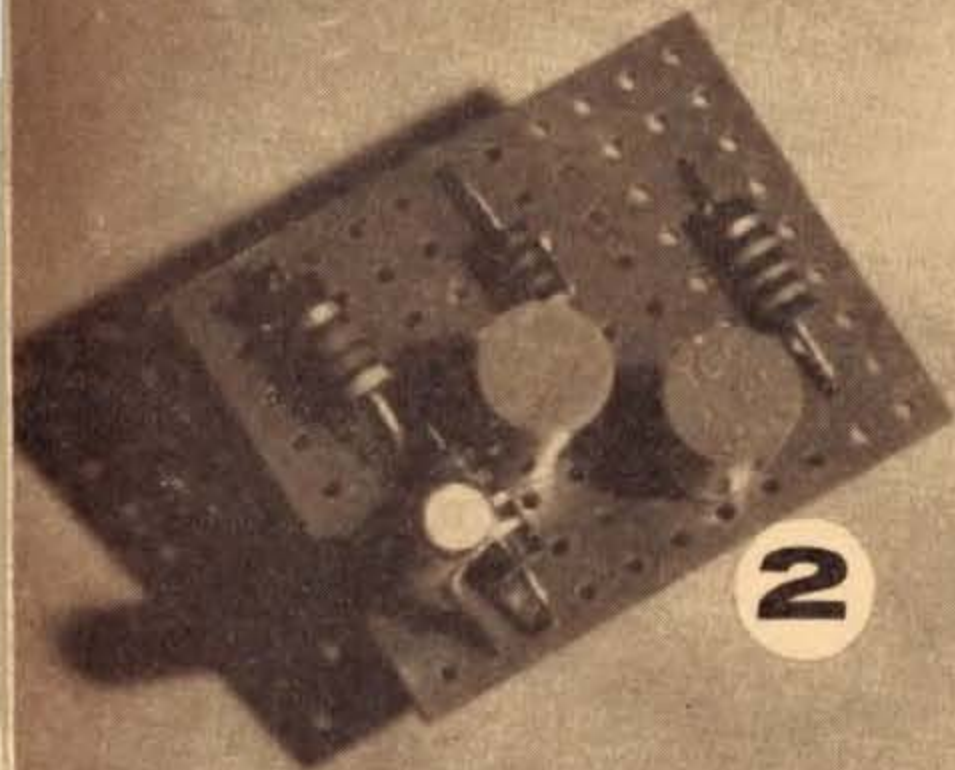

**2**

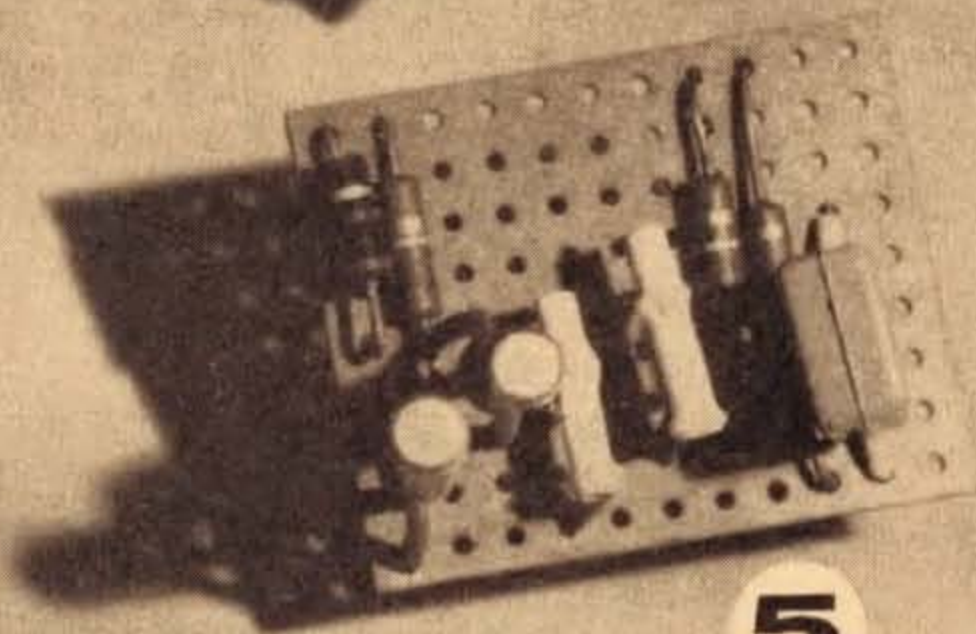

**5**

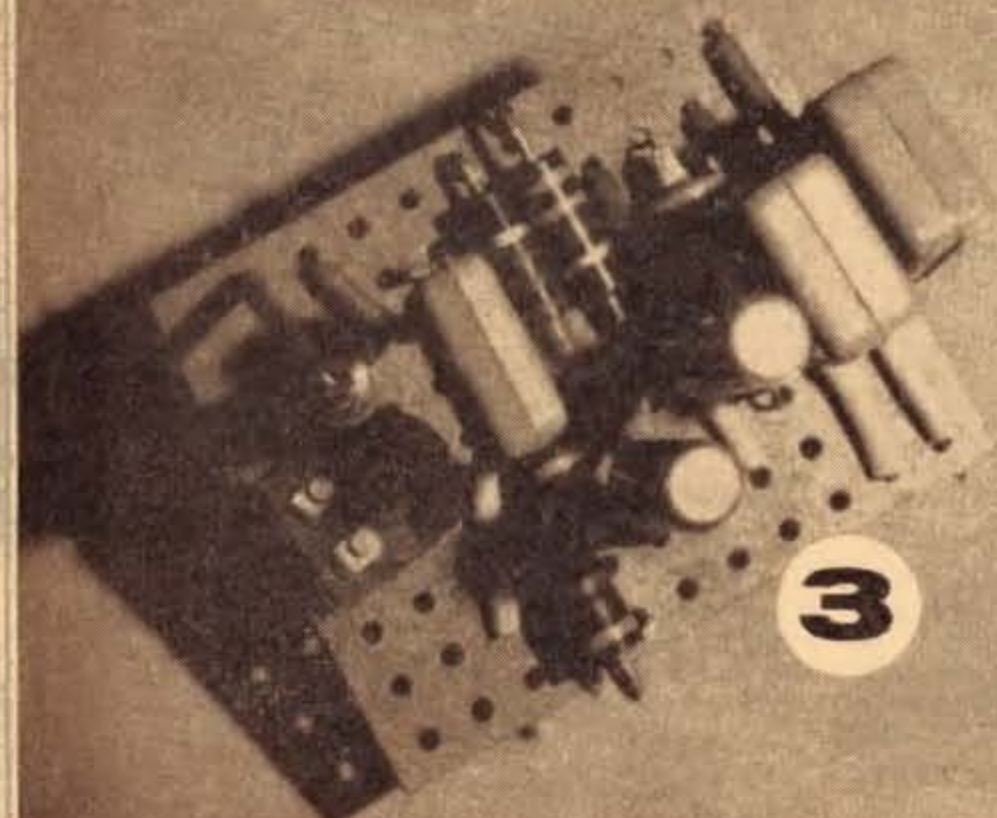

**3**

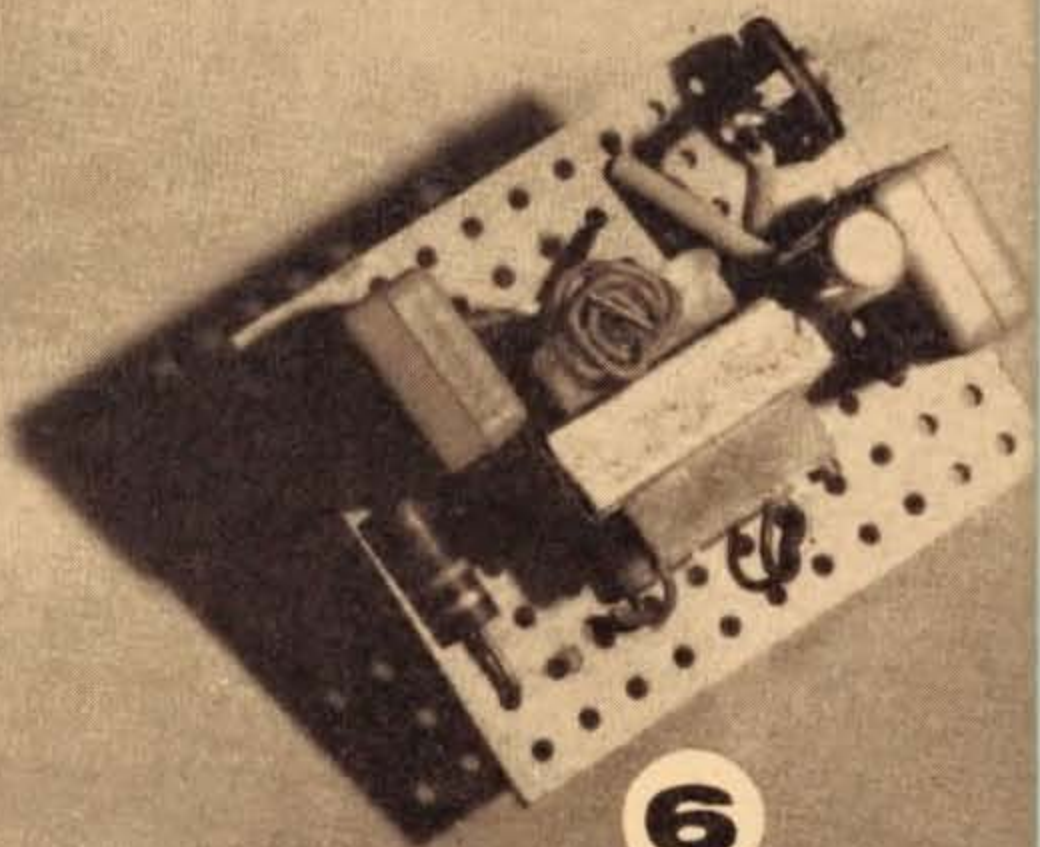

**6**



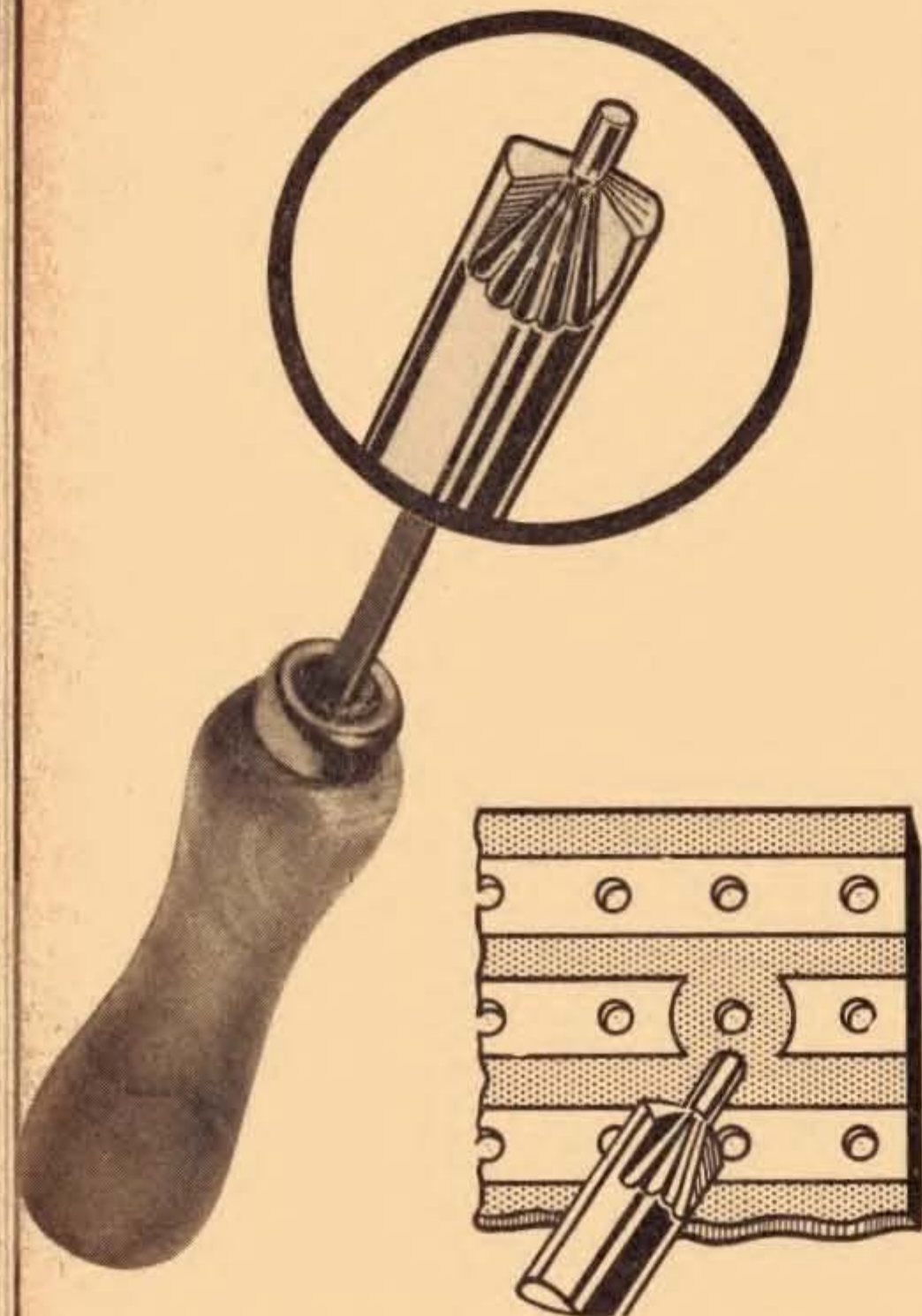

Fig. 2. General view of the tool with an enlargement showing the details of the cutting edges. The inset drawing shows the effect of using the tool on the copper strip

### COPPER STRIP BREAKS

It is not unduly difficult to process the breaks in the copper strips. There are a number of obvious methods of doing this which do not call for skill.

There is a special tool which can be used if a neat clean finish is required (see Fig. 1). As will be seen from the photograph in Fig. 2 it looks like a short twist drill, with a spigot in the centre for locating in the hole of the board. It is available from the makers of Veroboard (Vero Electronics Limited, South Mill Road, Southampton) and from a number of retailers under part number 2030/3011.

An alternative method is to use a sharp thin bladed penknife, adopting a backward and forward "sawing" action. The piece of copper to be removed should be cut on either side of the hole. It can then be lifted by inserting the blade carefully under the copper.

The following articles will be concerned with showing how a piece of Veroboard of such small dimensions can be used to build a number of interesting and useful electronic devices.

# pe

## MODULE ONE

THE FIRST article in this series shows just how many components can be accommodated on such a small piece of Veroboard as the one given in this issue.

The circuit, shown in Fig. 1, is a two-stage d.c. coupled audio amplifier with frequency selective feedback. The design is suitable for boosting and equalising the signal from a crystal or ceramic pick-up so as to obtain a "flat" output of sufficient level to drive a medium impedance, medium gain audio amplifier.

The unit can be employed to provide a signal of adequate level to permit the use of an ordinary crystal or ceramic pick-up with a transistor radio. Normally, of course, when such a pick-up is connected direct to the audio stages of a transistor radio the results are poor due both to lack of signal and poor impedance

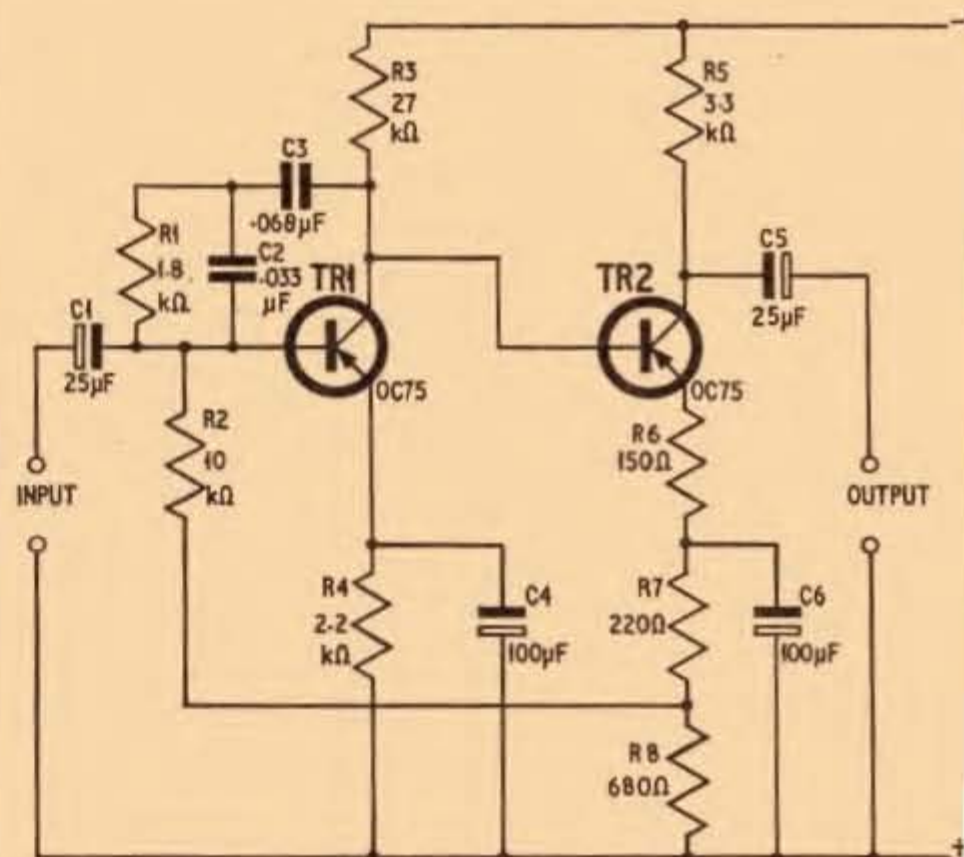
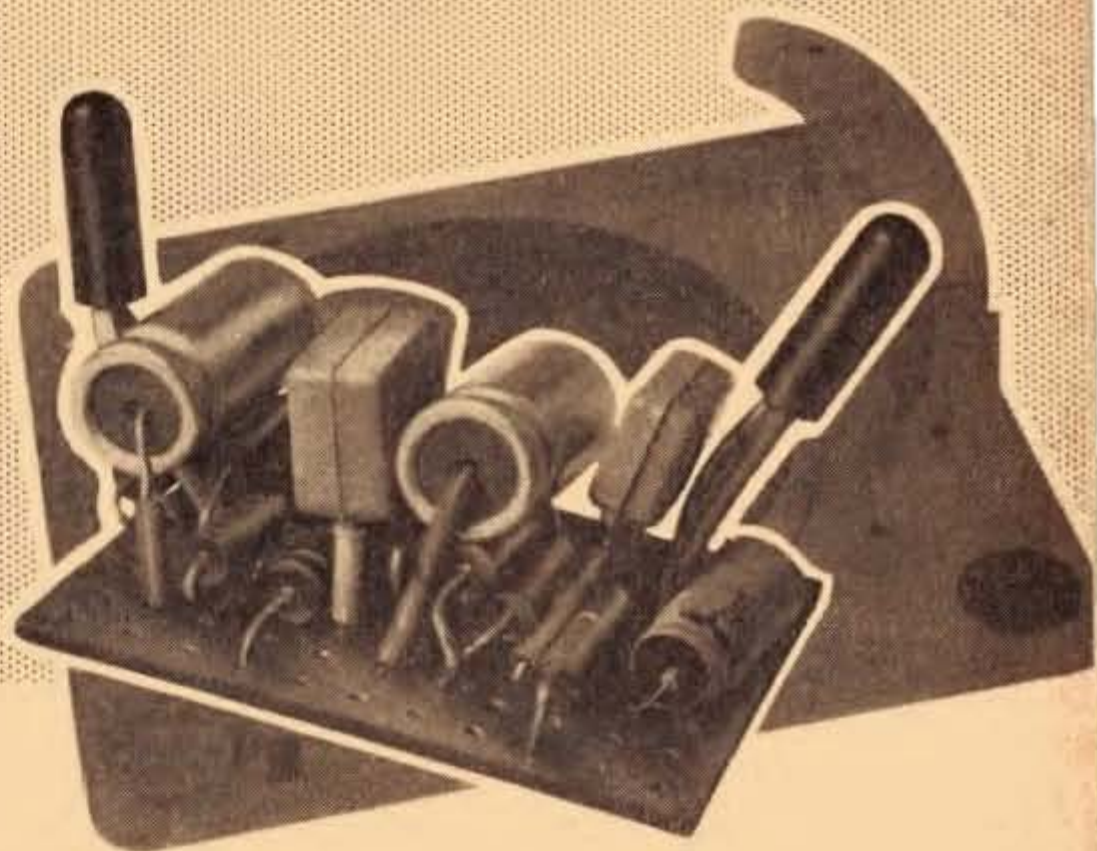

Fig. 1. Circuit diagram of the complete unit

# PICK-UP AMPLIFIER AND EQUALISER



matching. If matching and/or equalising is attempted, the signal is generally so badly attenuated that there is nowhere near enough drive and the output is very weak.

Moreover, some audio amplifiers require extra pick-up signal boost to drive them properly, especially when the signal is from a low-level pick-up. There may also be complications regarding the type of equalisation necessary for a crystal or ceramic pick-up when connection is made direct to the pick-up sockets of an amplifier or control unit.

The amplifier can help solve some of these problems. If necessary, the output signal can be applied to a "flat" input channel, such as the "radio" input. This avoids the possibility of "double equalisation", which is a state that can sometimes exist when a high impedance crystal or ceramic pick-up is applied to an equalised pick-up channel of an amplifier.

The amplitude of output signal from a crystal or ceramic pick-up is proportional to the extent of displacement of the stylus. This means that the signal voltage is increased with increase in amplitude of movement of the stylus. The rate of the movement or the velocity of the stylus has no direct bearing on the output voltage with this kind of pick-up. The reason for this is that the output is derived from piezo electricity when the crystal is subjected to mechanical stress by twisting, bending or flexing. The greater the stress, the greater the output voltage.

## MAGNETIC OUTPUT

A magnetic pick-up differs operationally from this in that its output signal amplitude is related to the velocity of the stylus, meaning that the output voltage rises with increase in frequency (i.e. velocity of the stylus movement). This is because the magnetic pick-up works rather like an electric generator, the voltage output of which rises with increase of armature velocity. The stylus acts as a component part of the armature which moves in a magnetic field.

When a gramophone record is made, the velocity of the cutter increases with increase in frequency, as shown by the curve in Fig. 2a. This is known as the recording characteristic. To replay such a recording a correction circuit, or equaliser, with a response complementary to that shown in Fig. 2a is necessary. This is shown in Fig. 2b. Hi fi amplifiers usually incorporate such a circuit in the pre-amplifier stages to obtain a "flat" or "equalised" output.

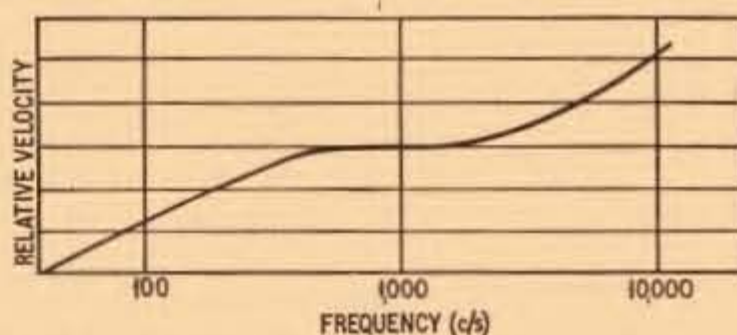

Fig. 2a. Recording characteristic

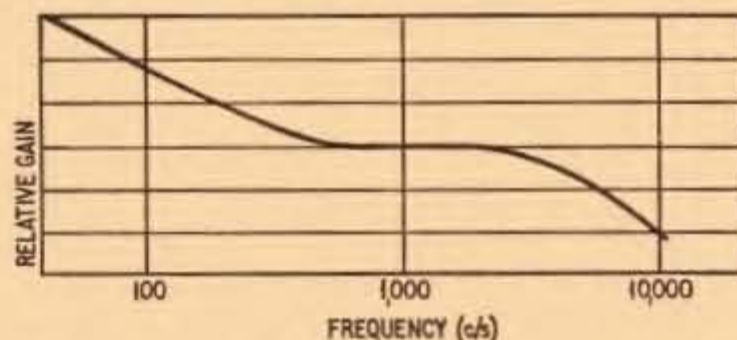

Fig. 2b. Replay characteristic using an equaliser

Since the output from a crystal or ceramic pick-up is proportional to the force to which the stylus is subjected when tracing a groove, the open-circuit voltage is approximately proportional to the logarithm of the frequency with reference to the recorded amplitude. Provided a crystal or ceramic pick-up is loaded with a very high impedance (in the order of 1 or 2 megohms), the output versus frequency characteristic is almost the inverse of the recording characteristic.

Equalisation is thus automatic.

Unfortunately, it is not always possible to load such pick-ups with very high impedance circuits, especially those employing transistors, since transistors have a low input impedance. Resistive pads can be used to increase the input impedance, but these greatly reduce the stage gain and emphasise signal/noise problems.

### LOW LOADED CRYSTAL

These problems can be solved by applying the pick-up signal to a low impedance input. When this is done the pick-up output voltage falls and the automatic equalisation function is destroyed. The loss of voltage can be restored by stage gain, of course, and the loss of equalisation by frequency selective feedback in the pre-amplifier.

The source impedance of a crystal or ceramic pick-up is a capacitive reactance. When it is loaded by a relatively low impedance circuit, the signal current passed from the source (pick-up) into the load (amplifier) increases with increase in frequency. This gives a characteristic similar to that of the magnetic pick-up. Thus, a crystal or ceramic pick-up loaded with a relatively low impedance (say, 10,000 to 50,000 ohms) can be applied direct to the equalised magnetic pick-up input of an amplifier, provided the output from a crystal or ceramic pick-up so loaded is sufficient to drive the amplifier. A good signal/noise ratio is achieved by feeding the pick-up current direct into the base of TR1 (see Fig. 1) via the coupling capacitor C1. The necessary equalisation is provided by R1, C2 and

## COMPONENTS . . .

### Resistors

R1	1.8k $\Omega$	R5	3.3k $\Omega$
R2	10k $\Omega$	R6	150 $\Omega$
R3	27k $\Omega$	R7	220 $\Omega$
R4	2.2k $\Omega$	R8	680 $\Omega$

All resistors  $\frac{1}{4}$  watt 10% carbon

### Capacitors

C1	25 $\mu$ F	25V elect.	(T.C.C. type CE8V)
C2	0.033 $\mu$ F		(T.C.C. type PMX2)
C3	0.068 $\mu$ F		(T.C.C. type PMX3)
C4	100 $\mu$ F	15V elect.	(T.C.C. type CE9H)
C5	25 $\mu$ F	15V elect.	(Radiospares)
C6	100 $\mu$ F	15V elect.	(T.C.C. type CE9H)

### Transistors

TR1	OC75	(Mullard)
TR2	OC75	(Mullard)

### Miscellaneous

Sample Veroboard, screened wire, 9 volt battery, battery connector.

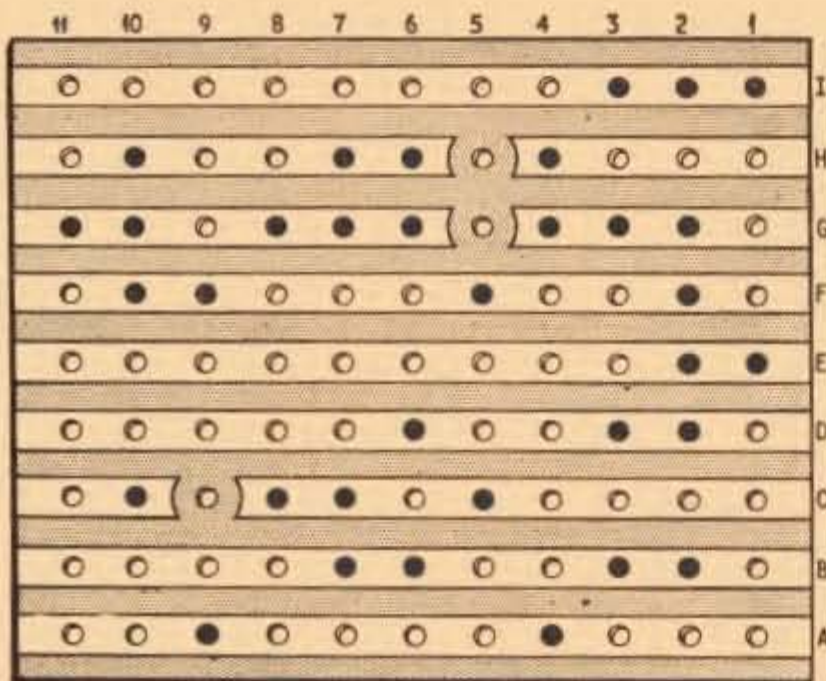

Fig. 3. Underside view of the board showing the copper strip breaks

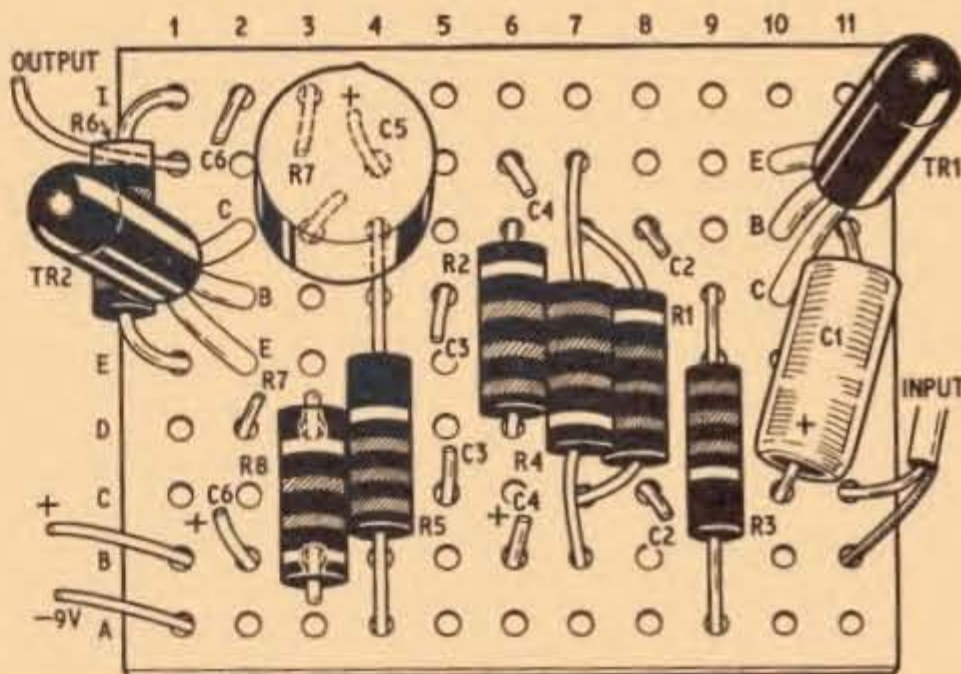

Fig. 4. Component layout. Capacitors C2, C3, C4, C6, and resistor R7 have been omitted for clarity but their connections are shown

C3 in the negative feedback circuit between the collector and the base of TR1, so that greater feedback occurs at the higher frequencies. The effective output at high frequencies will be relatively low.

The collector signal of TR1 is fed direct to the base of TR2 and the equalised output signal appears at the collector of TR2. This is coupled to the output via C5. Stabilisation at d.c. is provided by the direct coupling between TR1 and TR2, and the current feedback loop via R2. A little extra feedback is

provided by the unbypassed resistor R6 in the emitter.

The pattern of the Veroboard copper strips is clearly shown in Fig. 3, as also are the inter-connecting links.

The assembly of the components on the top of the Veroboard is shown in Fig. 4. It will be seen that the components are fairly close together, but there should be no great difficulty in obtaining components small enough to be accommodated.

The pre-amplifier circuit is based upon a design by Mullard Limited, ★

# pe

## MODULE TWO

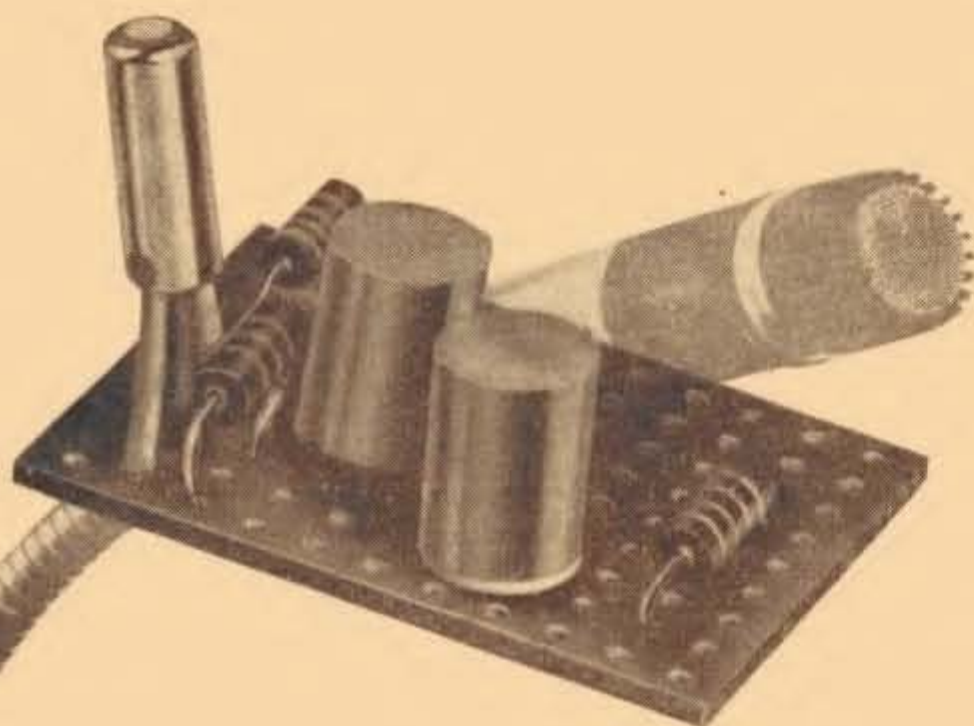

**T**HIS SECOND project takes the form of an impedance matching unit employing a single transistor. The circuit is given in Fig. 1. From this it will be seen that the transistor is connected in the common collector mode. This is sometimes referred to as an "emitter-follower" circuit, having features similar to that of the valve cathode follower circuit. The input signal is applied at the base and extracted from the emitter.

The circuit exhibits a high input impedance and a low output impedance. Although the current gain is high, the power gain is low because the voltage gain is less than unity, the power gain being the product of the voltage gain and the current gain.

### IMPEDANCE CONSIDERATIONS

The common-collector circuit is not used basically to amplify, but as an impedance matching device, often being part of a multistage amplifier, and acting as a buffer stage. It is also used to replace a transformer in audio circuits in particular where a good frequency response is required. Typical matched input and output impedances are in the order of 40,000 ohms and 1,000 ohms respectively. The input impedance can be further increased by the use of a series input resistor, such as R1, in the circuit. The output impedance is approximately equal to the source impedance divided by the current gain of the transistor, while the input impedance is approximately equal to the current gain of the transistor divided by the load resistor. Phase differences between input and output are responsible for slight discrepancies in these expressions, therefore Ohm's Law is not strictly obeyed. Thus, the higher the current gain of the transistor, the greater is the input impedance, while the greater the source impedance, the greater the output impedance.

One application of the device is for the coupling and matching of, say, a medium to high impedance output circuit on a tape recorder to a low impedance circuit on an amplifier.

# IMPEDANCE MATCHING UNIT

Match your high impedance microphone to a low impedance amplifier input with this **EMITTER FOLLOWER CIRCUIT**

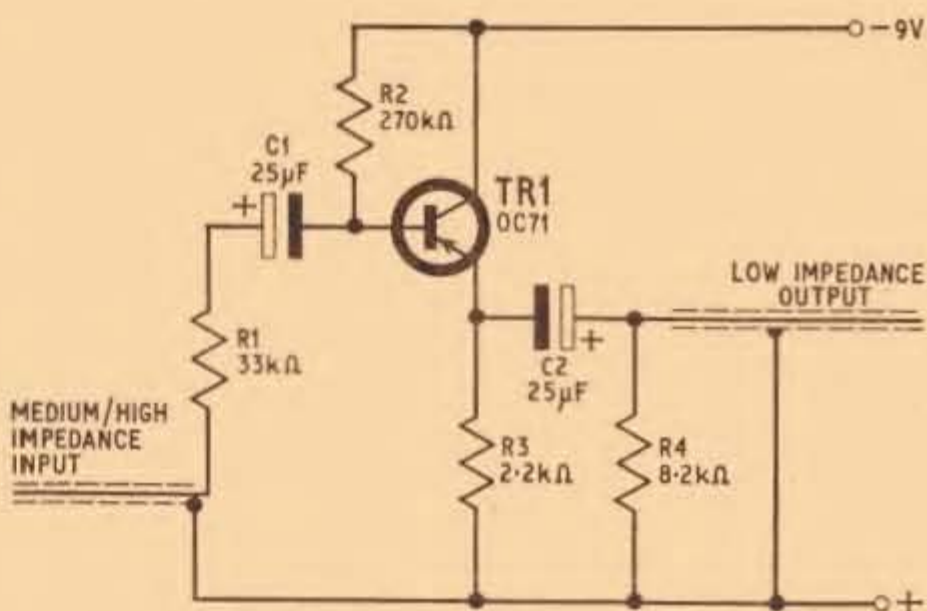

Fig. 1. Circuit diagram of the emitter follower

Another application is for the connection of a medium to high impedance microphone to a low impedance input on an amplifier or tape recorder. Note, however, that as the circuit does not amplify there must be a reasonable level of signal available from the microphone. Some tape recorders and amplifiers have a 600 ohm signal input. This will not accept the signal direct from a low or high impedance microphone or programme circuit unless correct matching is achieved. The gain of a 600 ohm programme source is usually adequate to overcome the lack of gain of the matching device.

### LOW IMPEDANCE MICROPHONE CABLE

It is also possible to connect the output of the device to a medium or high impedance tape recorder input channel without undue loss of quality. Thus, should one require to extend the microphone cable it is best to do this at low or medium impedance rather than at high impedance, since the cable is far less likely to pick up hum.

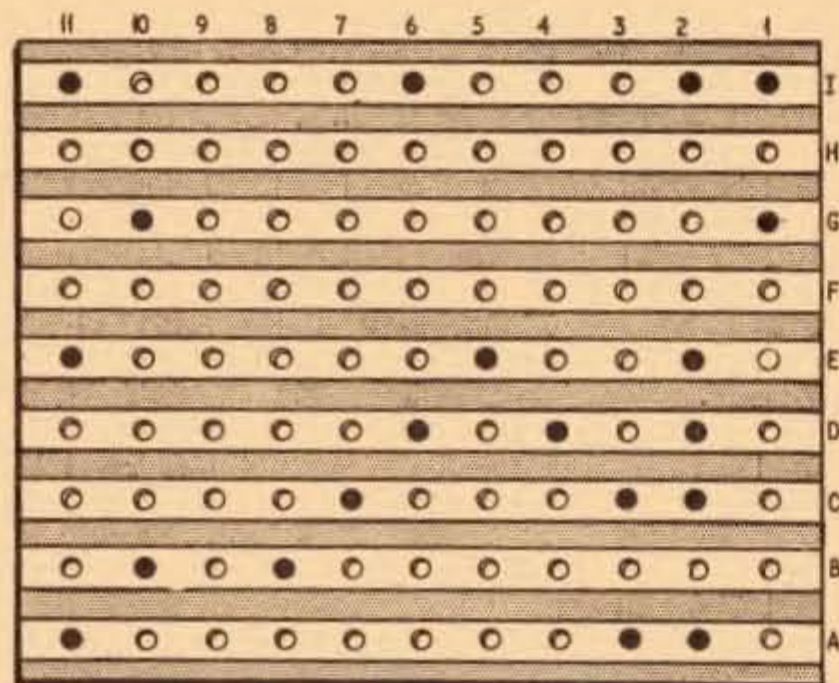

Fig. 2. Underside view showing component connections

While the input impedance is sufficiently high to match almost perfectly into the high impedance of a ribbon or moving coil microphone containing its own transformer (there are many of these now used with tape recorders), the impedance is not generally considered sufficiently high to match into a crystal microphone.

This is because a crystal microphone has a capacitive reactance and, in conjunction with the input impedance of the matching device, a response rising with increase in frequency is achieved. This gives treble boost or bass attenuation (see the article on the crystal pick-up amplifier and equaliser).

Provided that the microphone has sufficient output to counter additional loss in the matching device, this bass attenuation effect with a crystal microphone can be avoided by increasing the value of R1. The value should be increased to a maximum consistent with usable microphone gain.

If hum is troublesome near the microphone, the unit should be fitted into a metal housing, such as a small tobacco tin or similar container, the tin being connected to "earth" or battery positive.

## COMPONENTS . . .

### Resistors

R1	33k $\Omega$	} All $\frac{1}{4}$ watt 10% carbon
R2	270k $\Omega$	
R3	2.2k $\Omega$	
R4	8.2k $\Omega$	

### Capacitors

C1	25 $\mu$ F	25V	(T.C.C. type CE8V)
C2	25 $\mu$ F	25V	(T.C.C. type CE8V)

### Transistor

TR1 OC71 (Mullard)

### Miscellaneous

Sample Veroboard, screen wire, 9 volt battery, battery connectors

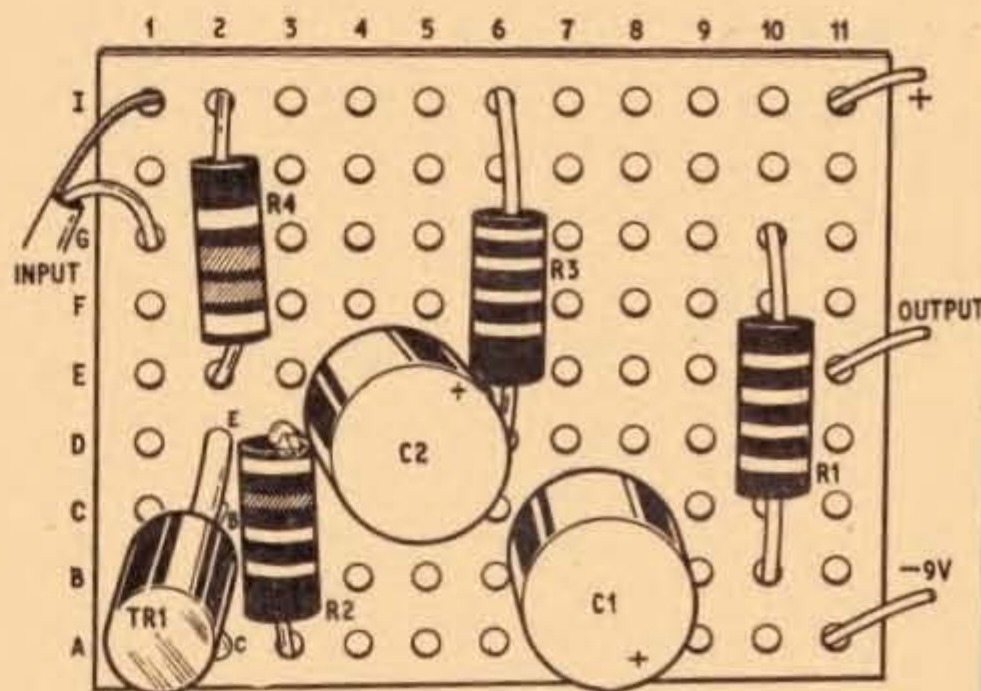

Fig. 3. Component layout of the unit

Resistor R4 across the output provides d.c. continuity should this be required at the microphone input socket of the tape recorder or amplifier. R3 is the emitter load resistor, while R2 sets the base current of the transistor. At normal room temperature this sets the collector current to about 0.3mA at 9 volts.

### CONSTRUCTION

Fig. 2 shows the pattern of the conductors on the Veroboard to suit this project. The connections of the components can be seen from the black "filled-in" holes. The components are mounted on the reverse side of the board, as with the other projects.

Fig. 3 shows the actual layout of the components on the reverse side of the board. There is no problem at all in the construction of this circuit, and it is ideal as a beginner's exercise. Check that the circuit is working by measuring the total battery current which should be in the order of 0.3mA, as already mentioned. ★



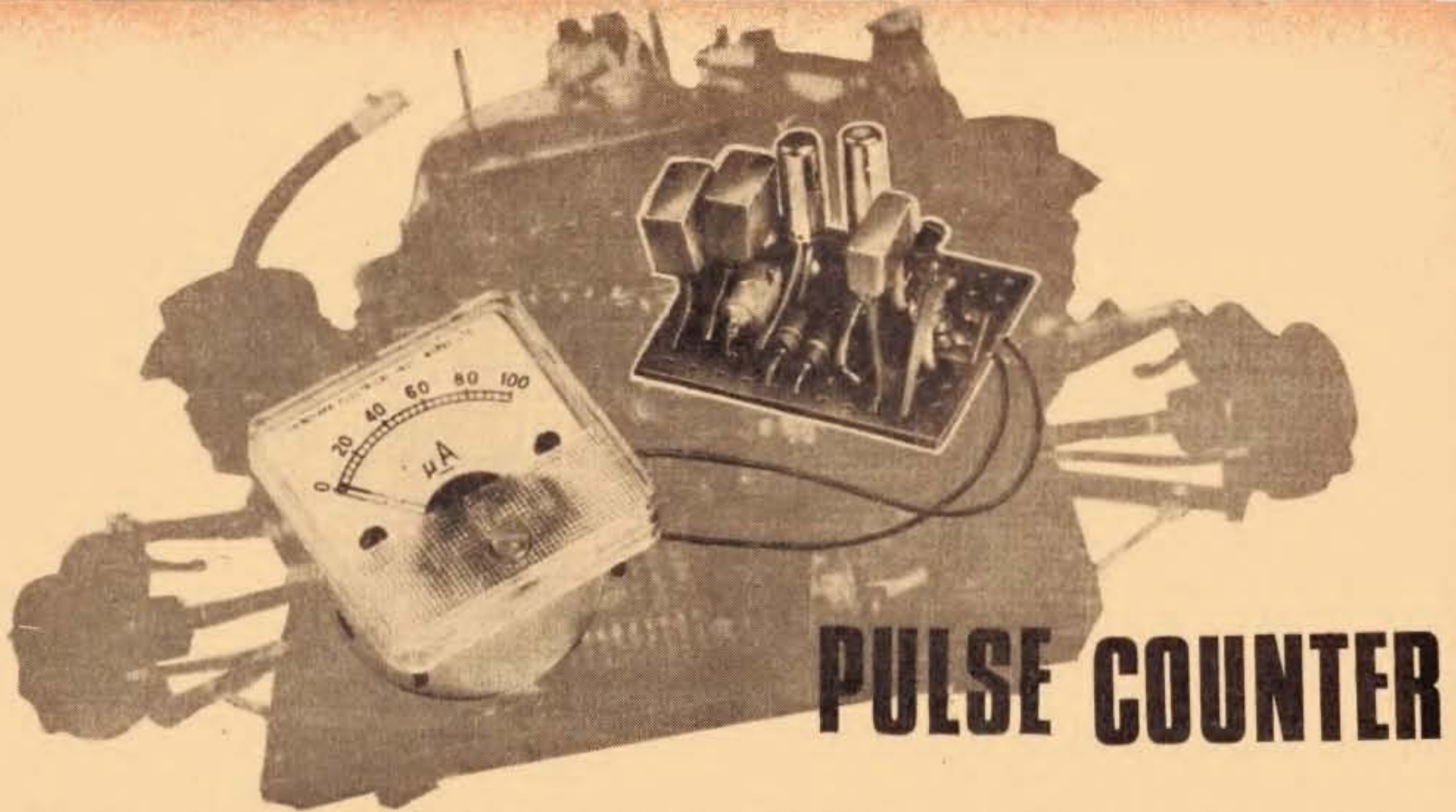

# PULSE COUNTER

**T**HIS THIRD project differs somewhat from the nature of the previous ones. Here we have a transistorised device designed to indicate pulse rate by deflecting the pointer of a moving coil meter. The deflection increases almost in direct proportion to the pulse rate.

One application of the device is for the measurement of the speed of an internal combustion engine by arranging for the pulses generated by the ignition system, at the contact breaker, to operate the counter and deflect the meter in proportion to the turnover speed of the engine. The scale of the meter may then be calibrated direct in revolutions per minute (r.p.m.).

The pulse repetition frequency of a four-stroke engine is equal to  $r.p.m. \times n/120$ , where  $n$  is the number of cylinders. Thus, a four-cylinder engine running at, say, 3,000 r.p.m. has an ignition pulse rate of 100c/s. Similarly, a six-cylinder engine running at 5,000 r.p.m. has a pulse rate of 250c/s. At the same speed, a single-cylinder, four-stroke engine produces nearly 42 pulses per second. The pulse rate is doubled on two-stroke engines at the same speeds. For instance, a single-cylinder, two-stroke engine running at 5,000 r.p.m. produces almost 84 pulses per second, while a four-cylinder, two-stroke engine running at 3,000 r.p.m. has a 200c/s pulse rate.

## THE CIRCUIT

The circuit is perfectly straightforward and is given in Fig. 1. The pulses are applied to the base of a transistor, via a filter comprising R1, R2, C1, and C2.

This deletes any "noise" which may be present on the pulses.

The transistor TR1 is normally at collector current cut-off, since the base is returned through R3 to the positive supply. However, the application of a pulse to the base switches the transistor "on" and thus causes a fall in voltage at the collector, due to the flow of collector current in R4. When the pulse finishes, the transistor is quickly switched off again, and the voltage at the collector rises to the negative supply value.

In this way amplified and clipped pulses occur at the collector of the transistor.

The pulses are fed through C4 to the diode D2. A direct voltage is thus, in effect, developed across VR1, and this is fed on to the meter from the slider of VR1.

Now, since the pulse current is fed through C4, the amount of current flowing through VR1, and hence the voltage developed across it, is governed by the reactance of C4. The higher the pulse rate, the lower the reactance of C4 and the greater the voltage developed

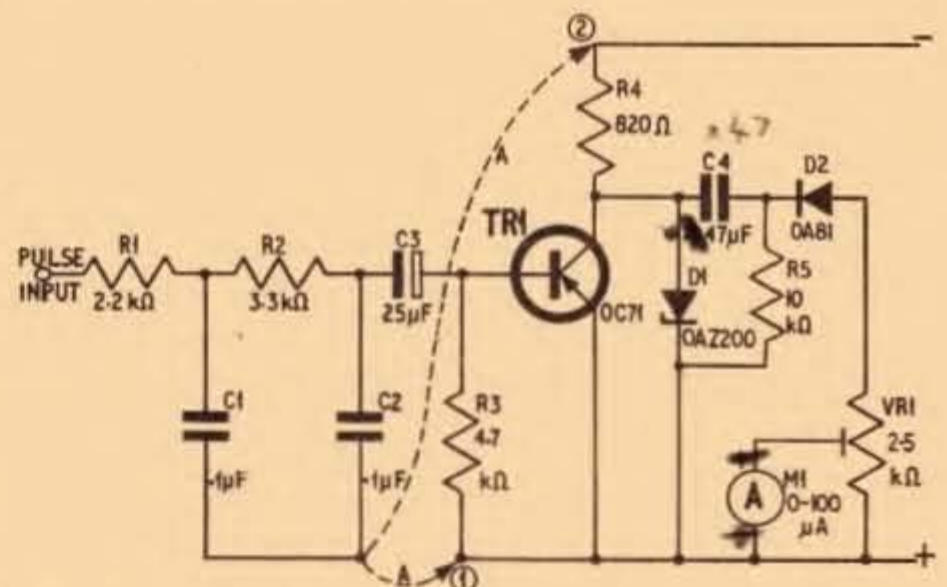

Fig. 1. Circuit diagram of the pulse counter. Capacitor C4 can be from 0.1 μF to 0.47 μF. See text for details of jumper link A



across VR1. Thus, it will be appreciated that the voltage across VR1 will rise almost in direct proportion to the pulse rate (i.e., the speed of the engine).

## HOW TO CALIBRATE

Potentiometer VR1 is used to calibrate the meter over the range of speeds required. For instance, if full-scale deflection at, say, 5,000 r.p.m. is required, then an engine would be run to this speed and the adjustment made for full-scale deflection.

Alternatively, calibration could be undertaken by an audio signal generator having a low impedance output. The frequency corresponding to the speed of the engine should be established on the generator and the signal applied "live" to the pulse input and the earthy side to positive supply line, with link "A" connected to point (1) on the circuit. The generator output should be turned well up to ensure adequate clipping by the transistor.

## COMPONENTS ...

### Resistors

R1	2.2k $\Omega$	R3	4.7k $\Omega$
R2	3.3k $\Omega$	R4	820 $\Omega$
All $\frac{1}{4}$ watt 10% carbon		R5	10k $\Omega$

### Potentiometer

VR1 2.5k $\Omega$  Preset skeleton miniature type

### Capacitors

C1	0.1 $\mu$ F (T.C.C. type PMX4)
C2	0.1 $\mu$ F (T.C.C. type PMX4)
C3	25 $\mu$ F 15V elect. (Radiospares)
C4	0.47 $\mu$ F (T.C.C. type PMX3)

### Transistor

TR1 OC71 (Mullard)

### Diodes

D1	OAZ200 Zener 4.7 volts (Mullard)
D2	OAB1 (Mullard)

### Miscellaneous

Sample Veroboard. Moving coil meter 100 $\mu$ A f.s.d. Battery (see text).

To work in conjunction with a car ignition system, the pulse input lead should be connected to the contact breaker on the distributor (that is, the terminal marked "CB" on the ignition coil). With positive-earth electrical systems (seen by the positive terminal of the battery being in direct contact with the metal chassis of the car), the negative supply lead on the unit should be connected to the ignition switch side of the ignition coil (that is, the terminal marked "SW") and the positive supply lead should be connected to battery positive or to the metal work of the car. On the unit itself, link "A" should be connected to point (1).

With negative-earth systems, the positive supply lead on the unit should be connected to the "SW" ignition coil terminal, while the negative supply lead should be connected to battery negative or to the metal work of the car. Also, link "A" on the unit should be connected to point (2).

It will be understood, of course, that the device could be used to measure not only pulse repetition rate but also audio frequencies from a low impedance source direct in terms of pointer deflection. For

greater sensitivity in the lower frequency ranges C4 should be measured in value. This can be up to 0.47 $\mu$ F, while maintaining a reasonable physical size for this application. This circuit lends itself to experimentation.

## COMPONENTS

The Zener diode D1 is a refinement which maintains a constant pulse amplitude. It avoids errors in reading due, for instance, to an increase in battery voltage at high charging currents and it allows powering over a range of about 6 to 15 volts. However, the circuit will work at slightly increased sensitivity without this diode.

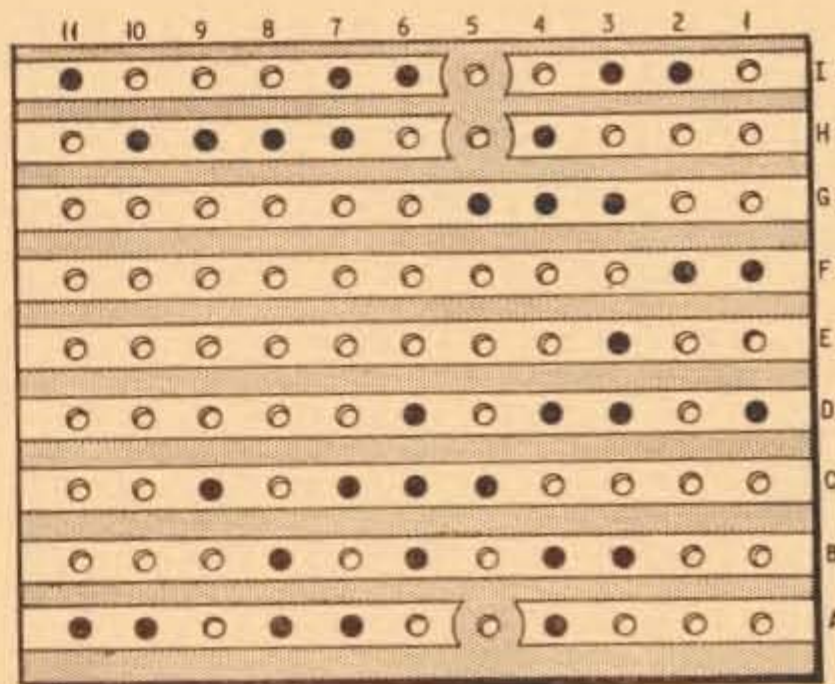

Fig. 2. Underside view showing the breaks in the copper strips and component connections

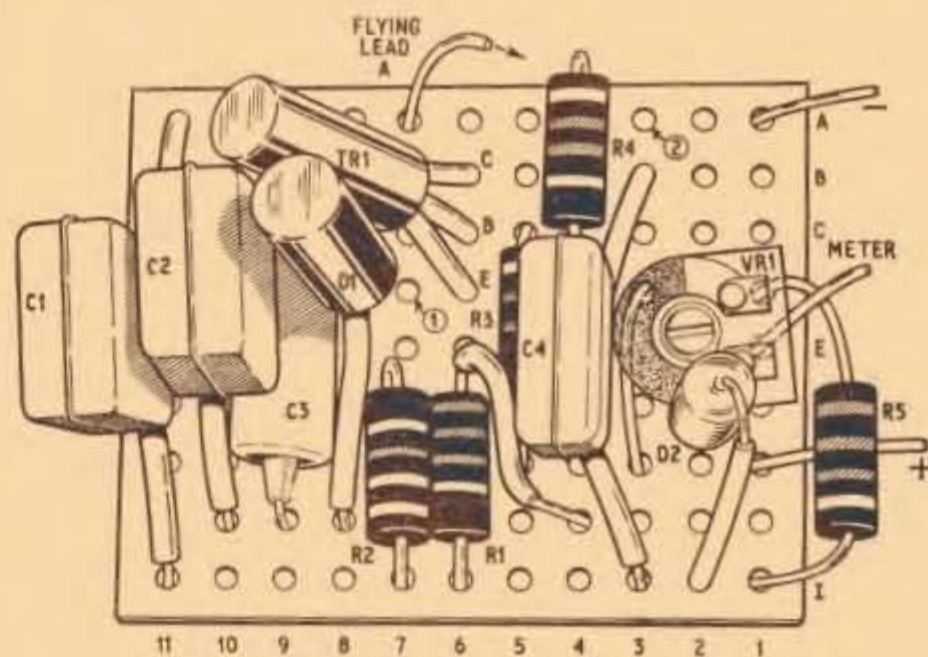

Fig. 3. Component layout and external lead connections. Holes 7D and 3A are the alternative connections for jumper link (A) from hole 7A (see text)

The pattern of the Veroboard to accommodate the components and circuitry is shown in Fig. 2. Link A and points (1) and (2) are also shown here.

Fig. 3 shows the physical layout of the components on the top of the Veroboard. Note here the polarity of the diodes and the electrolytic capacitor C3.

VR1 is a preset potentiometer mounted vertically in one corner of the board. If the three tags do not line up exactly with holes in the board, a good fit can be achieved by extending them with a piece of stout p.v.c. insulated copper wire. ★

## OUR BARGAIN OF THE YEAR

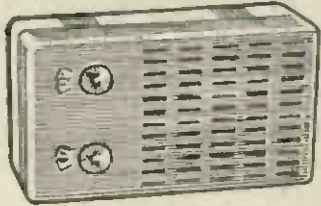

Complete kit of parts to build this 6-transistor 2 wave superhet receiver at only **45/-** plus 2/6 post and ins.

### "CORONET" Mk. III

It fully covers the medium-wave band and that part of the long-wave band to bring in B.B.C. Light. The circuit includes a highly efficient slab aerial and 2 1/2" P.M. speaker. Overall size approximately 4 1/2 x 2 1/2 x 1 1/2 in. Supplied complete with carrying case.

## YAXLEY SWITCHES

POLES	2 WAY	3 WAY	4 WAY	6 WAY	8 WAY	10 WAY	11 WAY	12 WAY
1	2/8	2/10	3/1	3/6	4/-	4/6	4/6	4/8
2	3/3	3/8	4/1	4/11	6/-	7/-	7/-	7/6
3	3/11	4/6	5/2	6/9	8/-	9/6	9/6	10/3
4	4/6	5/4	6/2	7/10	10/-	12/-	12/-	13/-
6	5/9	7/-	8/3	10/9	15/-	17/-	17/-	18/6
8	8/-	8/8	10/4	13/8	18/-	22/-	22/-	25/-
10	10/-	10/6	12/5	16/9	22/6	27/-	27/-	30/-
12	12/-	12/6	14/6	19/8	27/6	32/-	32/-	36/-
14	14/-	14/6	17/-	22/6				
16	16/-	16/6	19/6	25/6				

5 WAY 1 pole 3/6    2 pole 4/9    24 WAY 1 pole 15/-    2 pole 22/6

## P.E. TWO WAY INTERCOM

All components and transistors to build both units as described in the December issue of this magazine, are available price 75/- plus 2/6 post and insurance. Also cabinets, very modern looking, and quite suitable, although not exactly as specified, are available, 15/- each. No extra for carriage if ordered with components.

### Speaker Bargain



12in. High fidelity loudspeaker. High flux permanent magnet type with 8 ohm or 15 ohm speech coil. Will handle up to 10 watts. Brand new, by famous maker. Price 27/6, plus 3/6 post and insurance.

### 750 mW Transistor Amplifier



4 transistors including two in push-pull—input for crystal or magnetic microphone or pick-up—feed back loops—sensitivity 5 m/v.

Price 19/6. Post and Ins. 2/6.

35(2) Speaker 12/6 extra.  
48 Set—These are portable transmitter/receivers, complete except for crystals. Packed with valves and parts, easily rebuildable into other gear. Price 19/6. Post and insurance 3/6.

Toggle Switches—4-pole, changeover, with centre off. 10 amp contacts, 4/6. 2 pole, changeover, with 10 amp contacts, 3/6. 2-pole on/off 10 amp, 3/6. Single pole 5 amp, 2/6.

Indicator Lamps—Panel-mounting, with red globe, 2/6.

Ditto but flush front not coloured, 1/6.

Fuse Holders—Panel-mounting, fuse replaceable from front, 3/6.

Ditto but ex-equipment, 1/9 each.  
Vero-Board—several sizes in stock, prices on request.

Crystal Microphone Inserts—6/6 each.  
Filament Transformer—6.3v 2A primary normal mains, 5/6.

T.C.C. or Dubilier Tubular Condenser.  
.5 mf. 500 v. .... 10/- doz.  
.25 mf. 500 v. .... 7/8 doz.  
.25 mf. 350 v. .... 6/- doz.  
.05 mf. 500 v. .... 5/- doz.  
.0001 mf. 1000 v. .... 5/- doz.  
.001 1000 v. .... 6/- doz.  
.002 1000 v. .... 7/8 doz.  
.005 1000 v. .... 9/- doz.  
.02 750 v. .... 8/6 doz.  
.01 1000 v. .... 10/- doz.  
Ozone Outfit—for removing smells and generally improving any oppressive atmosphere. Kit consists of Phillips ozone lamps and mains unit, only needs box. 19/6, plus 3/6 postage and insurance.

### Dark Room Timer

As described in January issue. Kit of parts, all components but not case, 49/6, post and ins. 2/6.

### Battery Charger Kit

Comprises 5 amp. transformer, 5 amp. rectifier, metal case and meter to charge 6 or 12 volt batteries up to 5 amps. With variable charge rate, 39/6 each. Post and insurance 3/6.

### Waterproof Heater Wire

16 yd. length. 70 watts. Self regulating temperature control, 10/- post free.

### Thermostats

Type 'A' 15 amp. for controlling room heaters, greenhouse, airing cupboard. Has spindle for pointer knob, quickly adjustable from 30-80°F, 9/6 plus 1/- post. Suitable box for wall mounting, 5/-, P. and P. 1/-.

Type 'B' 15 amp. This is a 17in. long rod type made by the famous Sunvic Co. Spindle adjusts this from 50-550°F. Internal screw alters the setting so this could be adjustable over 30° to 1000°F. Suitable for controlling furnace, oven, kiln, immersion heater or to make flame-stat or fire alarm.



8/6 plus 2/6 post and insurance.

Type 'C' is a small porcelain thermostat as fitted to electric blankets, etc. 1 1/2 amp. setting adjustable by screw through side, 3/8, P. and P. 6d.

Type 'D'. We call this the Ice-stat as it cuts in and out at around freezing point. 2/3 amps. Has many uses, one of which would be to keep the loft pipes from freezing, if a length of our heater wire (16 yds. 10/-) is wound around the pipes, 7/6, P. and P. 1/-.

Type 'E'. This is a standard refrigerator thermostat. Spindle adjustments over normal refrigerator temperatures, 7/6 plus 1/- post.

### Infra Red Heaters

Make up one of these latest type heaters. Ideal for bathroom, etc. They are simple to make from our easy-to-follow instructions—uses silica enclosed elements designed for the correct infra-red wavelength (3 microns). Price for 750 watt element and metal casing as illustrated 19/6, plus 2/6 post and insurance. Pull-switch 3/- extra.

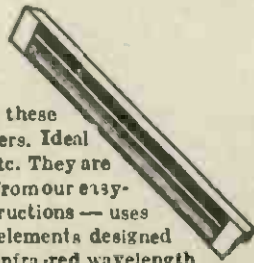

Where postage is not definitely stated add 2/- to all orders under £3.

# FREE! COLOUR BROCHURE



This wonderful new, attractively illustrated FREE brochure brings you full details of the tremendous range of tape recorders and many unique features that we as BRITAIN'S LARGEST TAPE RECORDER SPECIALISTS offer you.

Full details of recorders we particularly recommend, and a comprehensive list of all models available today are contained in the brochure, together with our unique FREE TRAVEL VOUCHER entitling you as a customer to full refund of your travelling expenses to and from any of our showrooms. Send for your FREE copy today, or call into any of our showrooms to see, hear and compare our fantastic selection of recorders.

## 5 STAR FEATURES

- ★ FREE TRAVEL TO AND FROM OUR SHOWROOMS
- ★ FREE DEMONSTRATIONS IN YOUR OWN HOME
- ★ OVER 300 MODELS FROM 15-243 GNS.
- ★ FREE ONE-YEAR SERVICING
- ★ FREE TECHNICAL ADVICE

Please send me your FREE BROCHURE (P.E.6)

Name.....

Address.....

**CITY & ESSEX TAPE RECORDER CENTRES LTD.**  
Head Office: Citex House, 191 Plashet Rd., London, E.13

## CITY & ESSEX TAPE RECORDER CENTRES

242/4 Pentonville Rd., N.1 (150 yds. from Kings Cross Station) TER 8200

228 Bishopsgate, E.C.2 (Opposite Liverpool St. Station) SIS 2609

2 Maryland Point Station, Stratford, E.15 (Adj. Station) MAR 5879

205 High St. North, E.6 (Opposite East Ham Station) GRA 6543

NOTE: Bishopsgate Showrooms open Mon.-Fri. 9 a.m.—6 p.m. Sunday 9.30 a.m.—2 p.m. Closed Sat. Other Showrooms open Mon.-Sat. 9 a.m.—6 p.m. Thursday to 1 p.m.

**ELECTRONICS (CROYDON) LTD.**  
266 LONDON ROAD, WEST CROYDON, SURREY  
Post orders to:  
43 SILVERDALE ROAD, EASTBOURNE, SUSSEX



# Choose Heathkit Equipment . . . for better performance and value

The British kit-sets that anyone can build first-time.

Construction is so simple . . . just follow the step-by-step as shown in the manual

## A selection of Test Instruments . . .

**5 in. FLAT-FACE GENERAL PURPOSE OSCILLOSCOPE.** Model IO-12U. An outstanding 'scope. "Y" sensitivity, 10 mV rms per cm at 1 kc/s; Bandwidth 3 c/s to 4.5 Mc/s. T/B 10 c/s to 500 kc/s. Kit £32.12.6. Assembled £41.10.0.

**2½ SERVICE 'SCOPE,** Model OS-1 Light (wt. 10½ lb.), compact, 5" x 8" x 14½". The ideal portable for servicemen. Kit £22.18.0. Assembled £30.8.0.

**TV ALIGNMENT GENERATOR,** Model HFW-1. 3.6 to 220 Mc/s on fundamentals. Unique electronic sweep oscillator. Built-in fixed and variable marker generators (5 Mc/s crystal). Kit £34.18.0. Assembled £44.10.0.

**MULTIMETER.** Model MM-1U. 0-1.5v to 1,500v A.C. and D.C. 150 µA to 15A D.C.; 0.2 to 20 MΩ. 4½" 50 µA meter. Kit £12.18.0. Assembled £18.11.6.

**R.F. SIGNAL GENERATOR,** Model RF-1U. Freq. coverage from 100 kc/s-100 Mc/s or six bands, on fundamentals and up to 200 Mc/s on calibrated harmonics. Kit £13.8.0. Assembled £19.18.0.

**6 in. DE LUXE VALVE VOLTMETER,** Model IM-13U. Measures ac and dc volts 0-1.5 to 1,500V in 7 ranges. Res. to 1,000 MΩ in 7 ranges. Modern styling, with gimbal mount. Kit £18.18.0. Assembled £26.18.0.

**VALVE VOLTMETER,** Model V-7A. DC volts to 1,500, AC to 1,500 rms and 4,000 V pk. to pk. Res. 0.1-1,000 MΩ. Kit £13.18.6. Assembled £19.18.6. RF Probe 309-CU £1.13.6 kit. HT Probe HV.336 £2.19.6 kit. Will extend range of models V-7A or IM-13U.

**ELECTRONIC SWITCH,** Model S-3U. Convert your 'scope to dual trace. Kit £12.18.0. Assembled £18.10.0.

**DECADE RESISTANCE,** Model DR-1U. Range 1-99,999Ω in 1Ω steps. Kit £10.8.0. Assembled £14.8.0.

**DECADE CAPACITOR,** Model DC-1U range. 100 µF to 0.111 µF in 100 µF steps. Kit £7.5.0. Assembled £10.8.0.

## Hi-Fi Equipment . . .

**"MALVERN" HI-FI EQUIPMENT CABINET.** Will house all your Hi-fi equipment. Left "in the white." Size: 39½ x 32 x 21½ in. Kit £18.1.0 (inc. P.T.)  
A wide range of other cabinets.

**"COTSWOLD" HI-FI SPEAKER SYSTEMS.** Acoustically designed enclosures, complete with 12 in. bass speaker, elliptical mid-range speaker, and tweeter to cover full frequency range of 30-20,000 c/s. Cross-over unit, level control, etc. Left "in the white." Standard "Cotswold", Size: 26 x 23 x 14 in. Kit £23.4.0

MFS "Cotswold" for the smaller room. Size: 36 x 16½ x 14 in. Kit £23.4.0

**SSU-1 SPEAKER SYSTEM.** A practical solution to the problem of a low-price speaker system. Two speakers. Without legs £10.17.6 Kit (inc. P.T.)  
With legs £11.12.0 Kit (inc. P.T.)

**5W MONO AMPLIFIER.** Model MA-5. A general purpose amplifier based on model S-33. Separate bass and treble controls, gram and radio inputs. Printed circuit. Kit £10.19.6. Assembled £15.10.0.

**AM/FM TUNER.** Covers FM 88-108 Mc/s, AM 16-50, 200-550, 900-2,000 M. Tuning heart (£4.13.6 inc. P.T.) and IF Amp. Case. Total £26.10.0 Kit

**6W STEREO AMPLIFIER.** Model S-33H. An inexpensive stereo/mono amplifier. Ideal for use with the Decca Deram lightweight pickup. Modern attractive styling. Kit £15.17.6 Assembled £21.7.6

**"GARRARD" AUTO RECORD PLAYER.** Model AT.6. A four-speed stereo/mono unit with auto. record selection. Fitted with R.105 crystal pickup £13.12.1 (inc. P.T.). With Decca Deram pickup £14.6.1 (inc. P.T.).

**HI-FI FM TUNER.** Range 88-108 Mc/s. Available in two units, sold separately. TUNER (FMT-4U) 10.7 Mc/s IF £2.15.0 (inc. P.T.). IF AMPLIFIER (FMA-4U) power supply and valves £13.3.0. Total Kit £15.18.0.

**9 + 9W HI-FI STEREO AMPLIFIER,** Model S-99. Ganged controls. Stereo/Mono Gram., Radio, Tape inputs. P.C. board construction. Attractive presentation. Kit £27.19.6. Assembled £37.19.6.

## Radios and other models . . .

**"OXFORD" LUXURY TRANSISTOR PORTABLE,** Model UXR-2. Beautiful solid leather case. LW and MW Coverage. Kit £14.18.0 (inc. P.T.)

**JUNIOR ELECTRONIC WORKSHOP,** Model EW-1. 20 exciting experiments can be made. Special solderless connections. Kit £7.13.6 (inc. P.T.)

**"MOHICAN" TRANSISTOR GENERAL COVERAGE RECEIVER,** Model GC-1U. Freq. coverage 580 kc/s to 30 Mc/s in 5 bands. Electrical band spread on 5 additional bands covers "amateur" freq. from 80-10 M. B.F.O. Tuning and Zener diode. Kit £37.17.6. Assembled £45.17.6.

**TRANSISTOR INTERCOM,** Models XI-1U and XIR-1U. Ideal for home or business. Each master (XI-1U) will operate up to 5 remote stations. XI-1U (Master) kit £10.19.6. Assembled £16.19.6. XIR-1U (Remote) kit £4.7.6. Assembled £5.16.0.

**GENERAL COVERAGE RECEIVER,** Model RG-1. Freq. coverage 600 kc/s-1.5 Mc/s. 1.7-32 Mc/s in 6 switched bands. Features incl. ½ lattice crystal filter. Kit £39.16.0. Assembled £53.0.0.

**50W PUBLIC ADDRESS AMPLIFIER,** Model PA-1. A multi-purpose unit, suitable for vocal and instrumental groups. 4 inputs for guitars, mics, etc. 2 heavy duty speakers, vol. indicator, variable tremolo, modern cabinet. Kit £54.15.0. Assembled £74.0.0.

**50W POWER AMPLIFIER,** Model MA-50. Ideal for sound reinforcing systems, etc. Kit £19.18.0. Assembled £27.18.0.

**80-10m AMATEUR TRANSMITTER,** Model DX-40U. Crystal controlled. Power input 75w. c.w. 60w. peak controlled carrier phone. Output 40w. Kit £33.19.0. Assembled £45.17.6.



IM-13U

HFW-1

IO-12-U

S-3U

MALVERN

COTSWOLD

FM TUNER

S-99

UXR-2

RG-1

PA-1

AT-6

**INTERNATIONAL MAIL ORDER SCHEME** covering the American Heathkit range of 250 models. Illustrated American catalogue and full details can be obtained from us for 1/- post paid.

Send for **FREE** British Catalogue of full range.

Deferred Terms over £10 in U.K.  
Prices include delivery U.K.

# DAYSTROM LTD.

Dept. P.M. 4, GLOUCESTER, ENGLAND

The Home of British Heathkit Models

Please send me **FREE BRITISH CATALOGUE** (Yes/No)  
**AMERICAN CATALOGUE**. 1/- incl. Postage

Full details of model(s).....

NAME .....  
(BLOCK CAPITALS)

ADDRESS .....

PM-4



# INEXPENSIVE OSCILLOSCOPE

By  
P. Cairns

## PART TWO

THE construction and layout of the oscilloscope is clearly shown in various detailed drawings and photographs included in this month's article.

As will be noted, tag boards and tag strips are used extensively throughout for the mounting of the smaller components, both above and below the chassis. The large block capacitors, mains transformer and smoothing choke are mounted on the top; also on the top are the tag boards associated with the e.h.t. supply, calibration unit and attenuator. The actual layout above and below the chassis can be seen from Figs. 5, 6 and 7.

### METAL WORK

Both the chassis and the front panel are made from  $\frac{1}{8}$  in aluminium sheet. Drilling details for the front panel are given in Fig. 4, while the chassis dimensions and drilling details appear in Fig. 5. The various brackets and clamps for the tag boards, c.r.t. mounting, etc., are also made from the same material.

It is advisable to cut out all the larger holes in the chassis before bending, the smaller holes being marked off from the actual components and drilled to suit. Few dimensions other than for valveholder centres, transformer, choke, and c.r.t. are given as the actual size of tag boards and components used will vary somewhat between individual units. The position of all parts is obvious, however, from the drawings and sufficient space is available to compensate for any differences in dimension which may occur.

It will be noted from the drawings that the mains switch S1 is mounted at the rear of the chassis. This saves having to run two lengths of mains lead the full length of the chassis—as would have to be done if the switch were on the front panel—and so prevents the pick-up and screening problems which would ensue if such an operation were carried out.

### SCREENED LEADS

It will also be noted that quite a number of screened leads are used throughout in the wiring. Here again this is to prevent stray pick-up and interaction between circuits. The use of screened leads also allows much more freedom in circuit layout. Generally speaking, the components associated with a particular stage are mounted on the tag board or strip next to that stage,

the connecting leads to the valve pins being short and direct. Some of the components however, particularly bias and grid return resistors, can be wired directly between the valve pins and a suitable earth tag or tag strip. The positioning of the various earth tags is shown in the appropriate drawings.

It may be mentioned that the layout in general is by no means critical. Those parts of the circuit with which rather more care should be taken are the first section of the Y amplifier and synchronising sections. Here, the leads should be kept as short as possible and well away from heater wiring, etc.

The heater leads themselves should consist of tightly twisted twin wire and should be wired in first, being laid along the bottom of the chassis. The sequence of heater wiring should be transformer x-x to V2, V3, V6, V5, and V4, in that order. The heater centre tap and h.t. secondary centre tap should be earthed together with the incoming mains earth lead to the earth tag on the rear of the chassis under the fixing screw of T1 (see Fig. 6). The heater wiring should be kept as clear as possible from the various valve component tagboards and associated wiring.

The e.h.t. and calibration components should be wired up on their tag boards as shown in Fig. 9 and flying leads provided for the various input and output connections. The tag boards are then mounted vertically on their brackets to the chassis (see Fig. 5). The flying leads can be made off later to fit in with existing wiring runs. This procedure not only makes construction simpler but gives a much neater appearance when finished.

If K3/25 rectifiers are used in place of OA210s, they will be found to be too large to mount on the tag board; they can, however, be mounted vertically between tag strips on the back of the bracket which supports the base of the tube.

The Y attenuator resistors are also mounted on a tag board with short leads connected (see Fig. 9), the tag board is then mounted vertically as close as is practicable behind S3 (see Figs. 5 and 6), to which the leads are then connected, these being kept as short as possible. C11 is connected directly between the input coaxial and OZ sockets, and S3. The earth tag on the rear of the coaxial socket and the earth tag on the base of V2 should be connected together, all earth

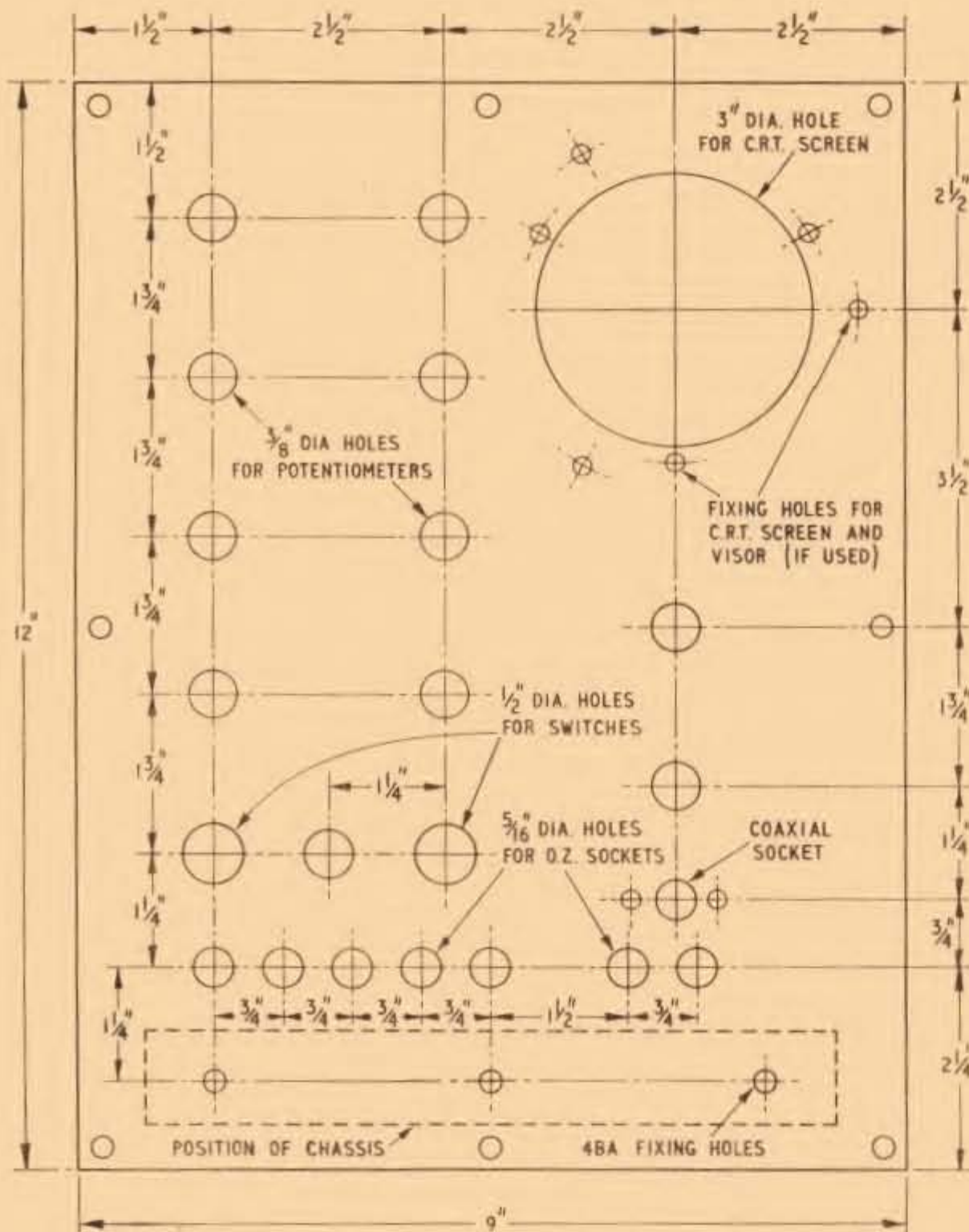

Fig. 4 (left). The front panel drilling details. This panel consists of a piece of aluminium sheet  $\frac{1}{8}$  inch thick

Fig. 5 (facing page, top). Plan view of the top of the chassis. All essential dimensions for the construction of the chassis appear in this diagram or in Fig. 6 immediately below. Details of the visor are also included

Fig. 6 (facing page, bottom). Side view of the complete assembly. Here are included certain dimensions not shown in the plan view, Fig. 5. The location of all the major components is indicated, but the wiring is omitted

connections in the attenuator circuit and V2 circuit being taken to this common earth line. All other wiring should be kept well away from this part of the circuit.

### WIRING UP THE CONTROLS

The various wires to the front panel controls are brought up from beneath the chassis through a number of grommets situated along the front of the chassis. Wiring from the c.r.t. base to the e.h.t. board is quite short as this board is mounted quite near the tube base. The e.h.t. leads to the focus and brilliance controls are rather long, but this does not matter as they are only carrying d.c. and are effectively decoupled.

The connections between the amplifier outputs and the tube deflection plates should be wired correctly, i.e. V3a anode must be connected to Y1 on the tube. This ensures that the convention of positive going signals giving an upwards deflection and the time base scan going from left to right is maintained.

If the 3BP1 tube is used, it should be mounted in the position shown in Fig. 11. Looking at the base end of the tube the spigot should be approximately 40 degrees anticlockwise from the lower vertical axis. This ensures that the time base line lies in the horizontal plane.

Types 3EP1 and 3GP1 should be mounted with their

spigot at bottom centre. This is also shown in Fig. 11.

Any final adjustment to the c.r.t. orientation can be made later with the oscilloscope in operation, after which the base clamp is locked in position.

Base connections for the three types of tube previously mentioned (3BP1, 3EP1 and 3GP1) are given in Fig. 11.

Perhaps it should be repeated at this juncture that all the above mentioned tubes are American surplus types. Although type 3BP1 is used by the author, the other two alternatives are very similar and can be used with confidence. Any minor readjustments that may be necessary for the 3EP1 or 3GP1 tubes will be described in the final article in this series which will deal with testing and setting up the oscilloscope.

### MU-METAL SCREEN

The mounting and fixing arrangements for the mu-metal screen can be seen in Figs. 5 and 6. This arrangement can be varied to suit individual requirements, as the clamping and fixing arrangements tend to vary slightly depending upon the type of screen obtained. There is ample space on the chassis to meet the various requirements and, as mentioned previously, the layout is not too critical so that the component layout on top of the chassis may be slightly rearranged if necessary.



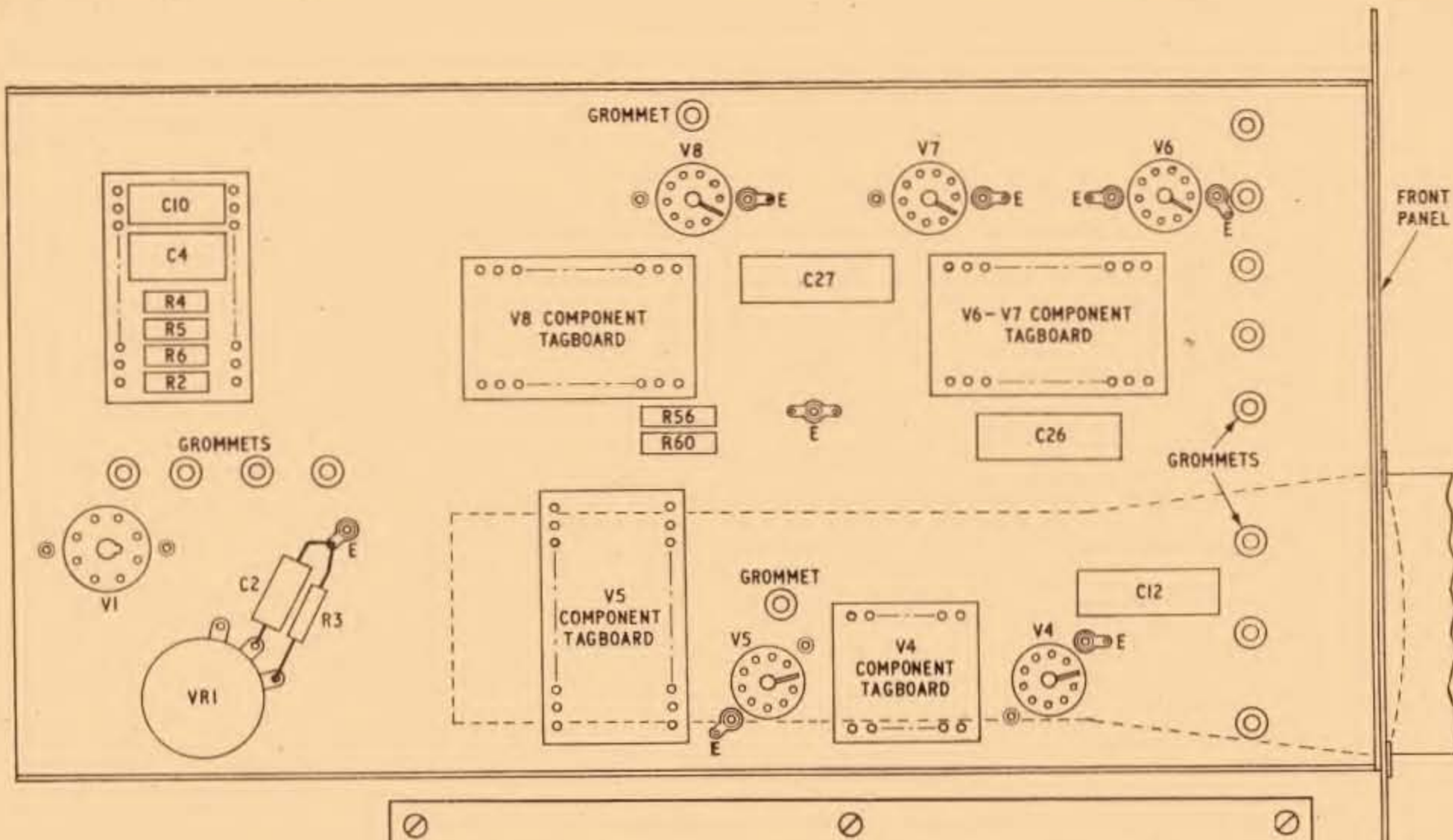

Fig. 7 (above). Layout of tag boards and other major items underneath the chassis. Details of the component tag boards are given in Fig. 9

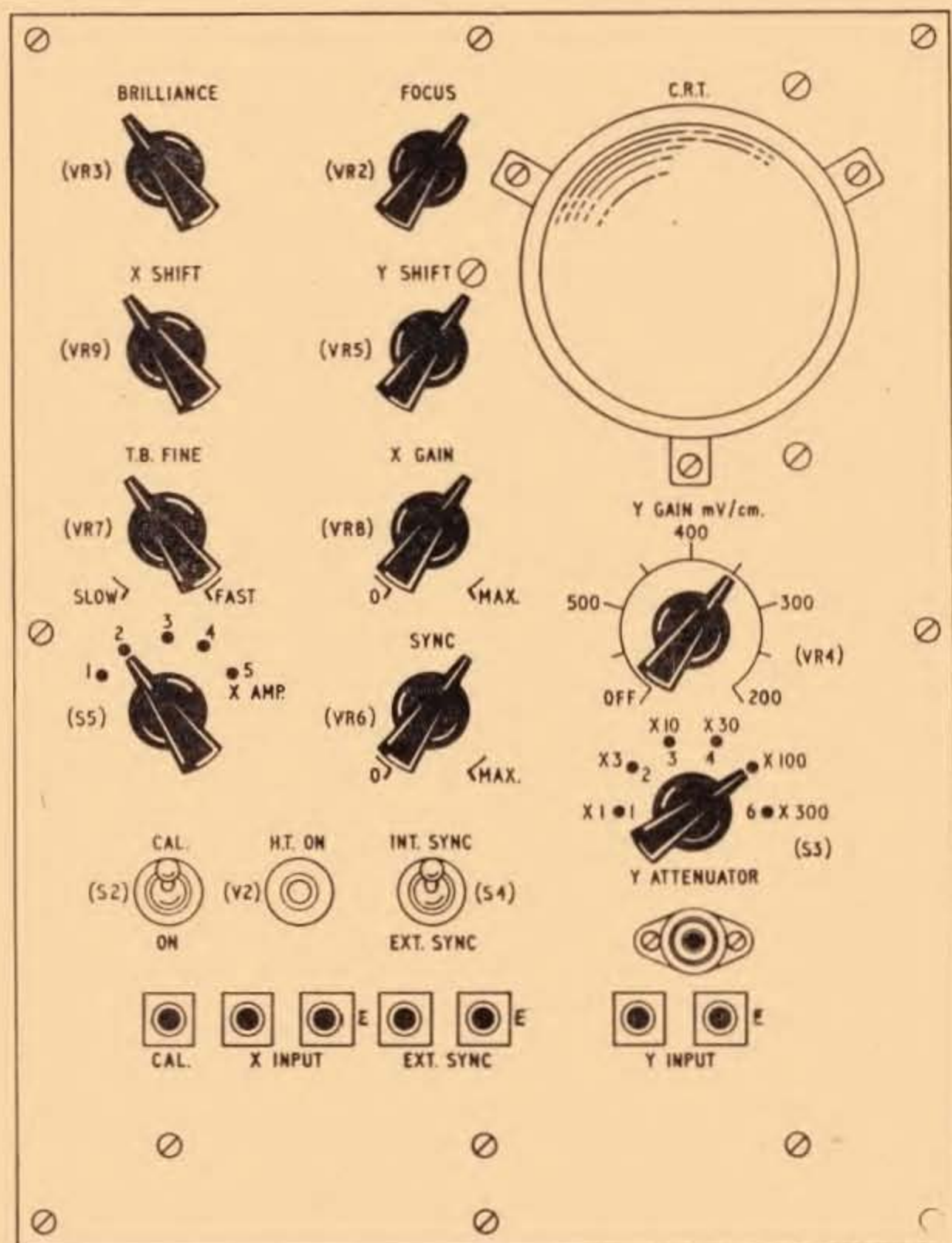

Fig. 8 (right). The completed front panel with all controls and sockets clearly labeled. Letter transfers are recommended for a neat and "professional" appearance



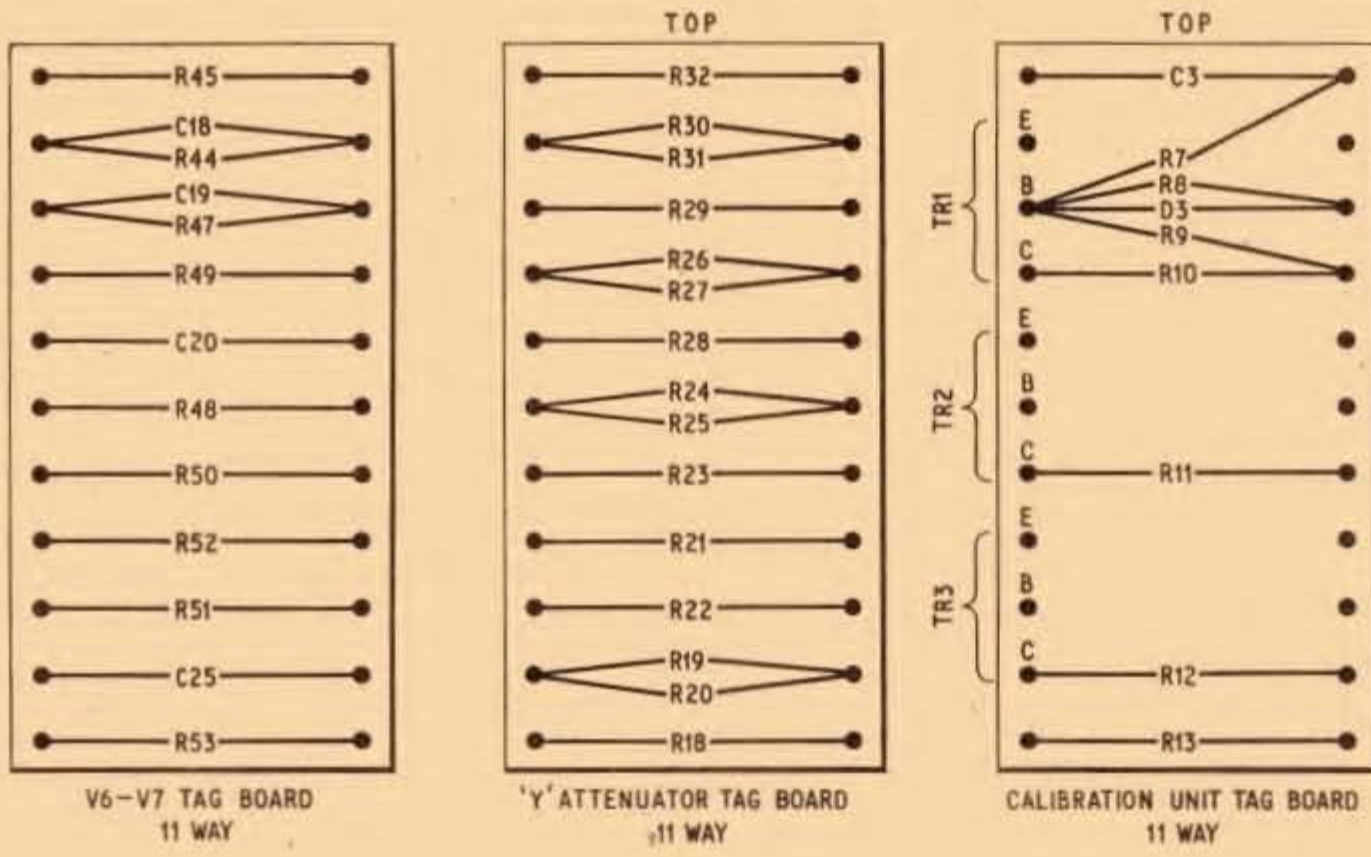

Fig. 9. Suggested arrangement of components on the various tag boards. Components should be assembled and wired up on these boards prior to the latter being fitted in position on the chassis

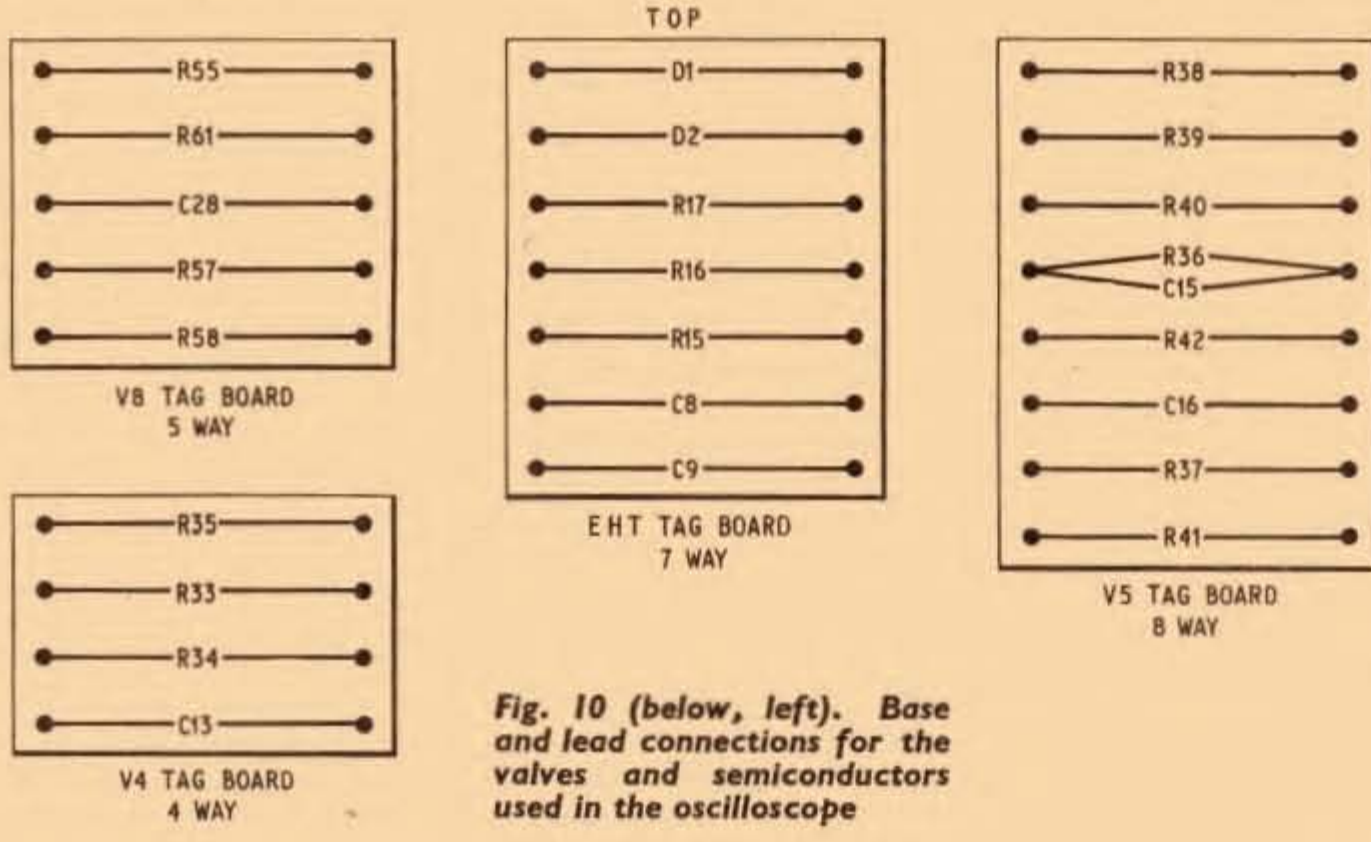

Fig. 10 (below, left). Base and lead connections for the valves and semiconductors used in the oscilloscope

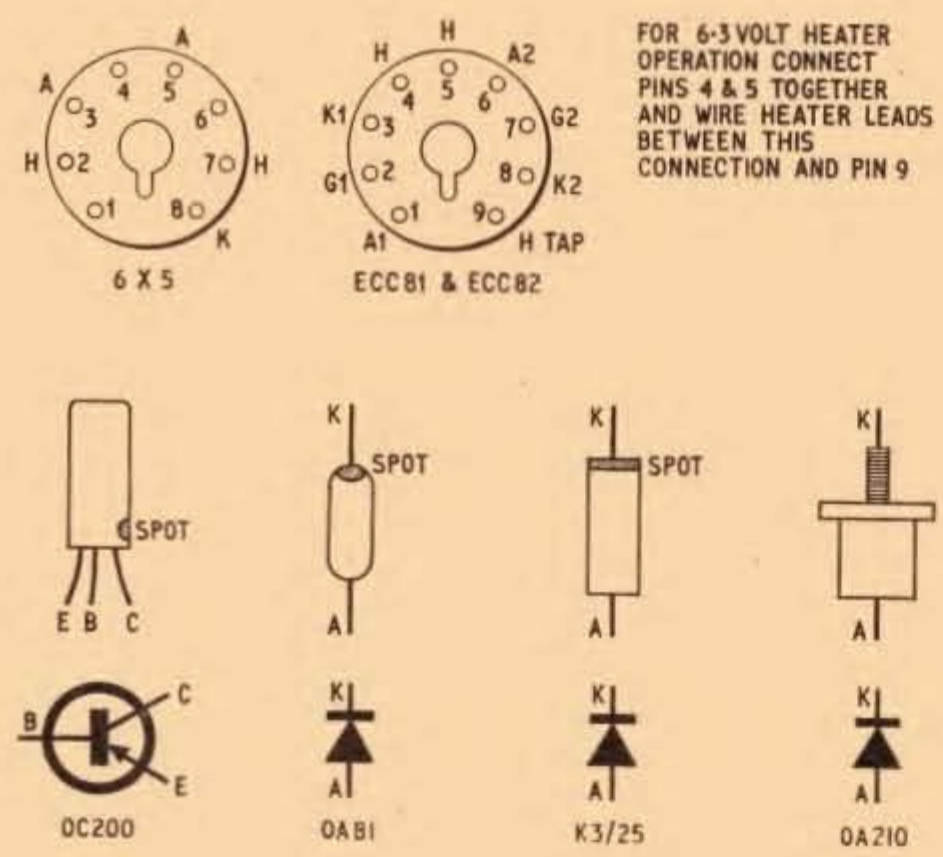
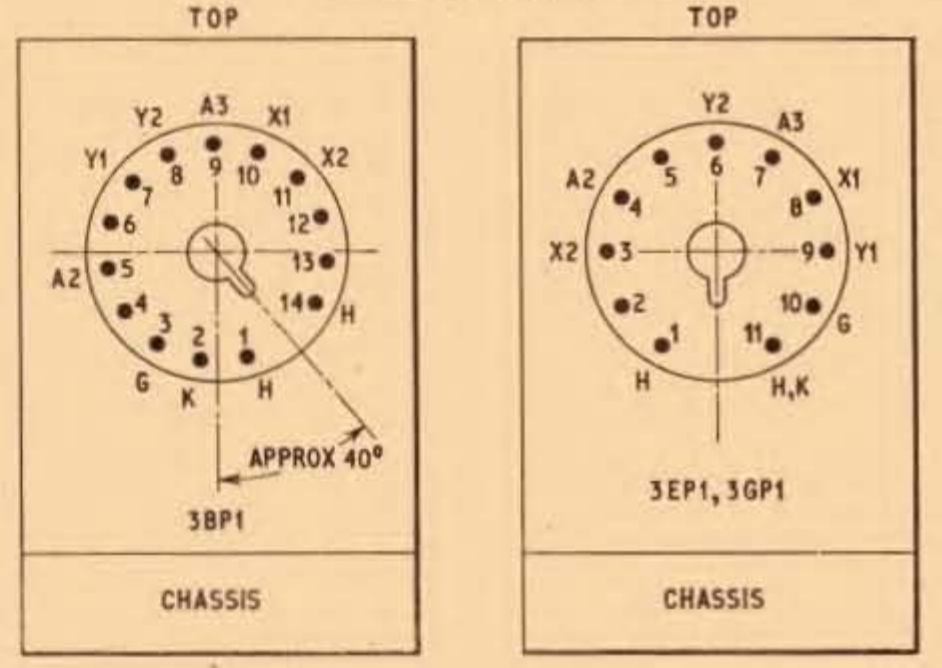

Fig. 11 (below). Base connections for the three types of cathode ray tube. Note the position of the spigot in each case; this determines the correct alignment of the trace with respect to the chassis of the instrument



Some components not shown in the drawings are the time base capacitors C21–C24. The large capacitor C24 is mounted as in Fig. 5, the remainder (C21–C23) are connected directly between the common point on this capacitor and the tags on S5. This keeps the lead length between the time base capacitors and S5 to a minimum.

Another point which should be mentioned is the positioning of the mains transformer and smoothing choke. These two components should be aligned in the position where the magnetic field has least effect on the c.r.t. and the connections to it, i.e. the field should run parallel with the c.r.t. and not at right angles to it. This is to prevent magnetic pick-up effects which can give a distorted trace—and is, of course, one of the reasons why the mu-metal shield for the c.r.t. is of such importance.

The base and pin connections for the various valves, transistors and diodes are shown in Fig. 10.

Details of the lettering and layout of the controls, switches, sockets, etc., are shown in Fig. 8. The various titles and scales can be put on the front panel in a number of different ways. For those with a steady neat hand they can be marked with draftsman's ink. Another method is to use letter transfers of which a wide selection of types are available. Otherwise the various titles can be simply typed out and transferred by means of double backed adhesive paper to the front panel. Finally, a coating of clear quick drying lacquer (clear nail varnish is ideal) over the labels will keep them clean and legible.

### VISOR AND GRATICULE

Two "extras" which may be simply constructed and add to the usefulness and appearance of the instrument are a visor and graticule.

The dimensions of a suitable visor are shown in Fig. 5. This item can be made from  $\frac{1}{2}$ in sheet brass bent around a former of suitable diameter, the joint being soldered. Alternatively, a tin of the right diameter can be cut to the appropriate length. The visor can be fixed to the front panel by means of three small right angle lugs, soldered to the visor and screwed into the front panel.

The inside of the visor should be painted matt black to prevent reflection and a piece of split heavy wire insulation (a piece of coaxial cable with the centre core and screen removed is ideal) gummed around the outer edge to prevent any cuts occurring. The visor will allow waveforms to be viewed under conditions of high ambient light and also help to prevent accidental damage to the c.r.t. face.

A graticule can be easily made from a piece of  $\frac{1}{8}$ in perspex or other transparent material. The engraving can be performed with a sharp cutting tool with a fine edge, care being taken not to let the tool slip when carrying out this operation. First the two axes, horizontal and vertical, are marked exactly at right angles to one another so that they intersect exactly in the centre of the circle of material. A series of fine lines exactly one centimetre apart are then marked from each of these centre lines so that the final result is a circle of material divided into one centimetre squares which just fits inside the visor and can be pressed flat against the face of the tube. The finely etched lines can be filled with black crayon so as to be easily seen against the tube face.

The advantage of a graticule is that it allows quick and reasonably accurate calibration checks to be made and allows signal levels to be read direct, the Y amplifier

being calibrated in volts per centimetre. When making such measurements care must be taken to view the screen *directly* and not at an angle as this leads to parallax errors and consequent inaccuracy in the measurements.

Another point which may be mentioned is that while the calibration unit is an obvious asset to the oscilloscope, it is by no means essential to its function and can be omitted if required. For this reason the calibration circuit in Fig. 1 is shown inside a broken line and can always be added at a later date if necessary.

### HOUSING THE INSTRUMENT

Finally, the outer case can be constructed from  $\frac{1}{4}$ in or  $\frac{3}{8}$ in plywood or, if adequate workshop facilities are available, from  $\frac{1}{8}$ in aluminium with metal bracing at the edges and corners. A number of ventilation holes should be drilled around the top and bottom edges of the sides, and a hole must be cut in the back plate in the appropriate position to allow access to the mains switch. A three or four inch handle on top of the case helps towards making the instrument relatively portable.

### ERRATA

The following amendments to Part 1 of this article (last month) should be noted.

**Specification** (page 328): Time base range No. 3 should be 1ms/cm to 100 $\mu$ s/cm.

**Components list** (page 331): R45 is rated at 1W; add C28 0.1 $\mu$ F paper 150V.

**Fig. 3. Time base generator and X amplifier circuit** (page 335): Capacitors C21 to C24 inclusive have been inadvertently reversed in this diagram. These capacitors should be connected to the time base switch S5 as follows: switch position (1) C24; (2) C23; (3) C22; (4) C21.

**Next month: Testing and setting up the oscilloscope**

## A TRANSISTOR TV RECEIVER FOR THE HOME CONSTRUCTOR!

- ★ Fully transistorised, except for the c.r.t. and e.h.t. rectifier.
- ★ Operates from 12V car battery, Ever Ready TV1 dry battery, or a.c. mains.
- ★ 14in 90° picture tube.
- ★ Unit construction for flexibility
- ★ High performance using latest techniques.
- ★ Low noise level (better than 5dB) giving clear "snow-free" pictures.

*Described in April issue of*

## PRACTICAL TELEVISION

*On Sale March 18*



# Enjoy yourself and Save Money by Building Heathkit models

A wide range of well designed quality kit sets to choose from

## A KIT FOR EVERY INTEREST ... HOME, SERVICE WORKSHOP, LABORATORY

### Ease of assembly is guaranteed

Even for those without previous experience—by the comprehensive, yet simple step-by-step construction manuals supplied with every Heathkit model.

### Save £ £'s building the models

Heathkit units cost considerably less than comparable pre-assembled equipment. You cannot buy the parts any other way as cheaply.

### Guaranteed performance

Every Heathkit product—sembled in accordance with our comprehensive construction manuals is guaranteed to meet published performance specifications, or your money will be cheerfully refunded.

### Convenient credit terms

By taking advantage of our credit terms—you can enjoy your model right away—and pay for it in easy monthly instalments. Deferred terms available over £10 in U.K.

### AUDIO

Cabinets, Turntable units, Mono and Stereo Amplifiers, Pick-ups, Speakers, Speaker Systems, Mono and Stereo Control Units, Tape Pre-amplifiers, Tape Decks, Transistor Mixer.

### RADIO

AM/FM and FM Tuners, Transistor Radios, SW and Communication Receivers.

### TEST INSTRUMENTS

A wide range of Audio Test, Home Workshop, Service and Laboratory Instruments.

### AMATEUR GEAR

A wide range of equipment.

### MISCELLANEOUS

Hobby kits for the youngster, Tool kits, Intercoms, Electronic Organs, PA/Guitar Amplifiers, etc.



'SCOPES



POWER SUPPLIES



TRANSISTOR TESTER



SIGNAL GENERATORS



VALVE VOLTMETERS



TV ALIGN. GENERATORS

## Instruments for Test, Service, Home Workshop

3 in. **LOW-PRICED OSCILLOSCOPE**, Model OS-2. Ideal for servicemen. Compact: 5" x 7 1/2" x 12". Wt. 9 1/2 lbs. "Y" bandwidth, 2 c/s—3 Mc/s. T/B 20 c/s—200 kc/s in 4 ranges. Kit £22.18.0. Assembled £30.8.0.

**MULTIMETER**, Model MM-1U. Ranges 0-1.5v to 1,500 v A.C. and D.C. 150 µA to 15A D.C.; 0.2 to 20 MΩ. 4 1/2 in. 50µA meter. Kit £12.18.0. Assembled £18.11.6.

5 in. **FLAT-FACED OSCILLOSCOPE**, Model IO-12U. Lab. performance at utility 'scope price. "Y" bandwidth 3 c/s to 4.5 Mc/s. T/B 10 c/s to 500 kc/s in 5 steps. Built in lv calibrator. Dim.: 8 1/2" w x 14" h x 17" deep. Kit £35.17.6. Assembled £45.15.0.

**TRANSISTOR TESTER**, Model IM-30U. Unmatched in quality, performance and price. Provides complete d.c. analysis of PNP, NPN transistors and diodes. Internal battery for tests up to 9 v. Kit £24.18.0. Assembled £35.10.0.

**R.F. SIGNAL GENERATOR**, Model RF-1U. Freq. coverage from 100 kc/s-100 Mc/s on six bands on fundamentals and up to 200 Mc/s on calibrated harmonics. Kit £13.8.0. Assembled £19.18.0.

6 in. **DE LUXE VALVE VOLTMETER**, Model IM-13U. Measures ac and dc volts 0-1.5 to 1,500 V in 7 ranges. Res. to 1,000 MΩ in 7 ranges. Modern styling, with gimbal mount. Kit £18.18.0. Assembled £26.18.0.

**TV ALIGNMENT GENERATOR**, Model HFW-1. 3.6 to 220 Mc/s on fundamentals. Unique electronic sweep oscillator. Built-in fixed and variable marker generators (5 Mc/s crystal). Kit £37.18.0. Assembled £47.10.0.

**DECADE RESISTANCE**, Model DR-1U. Range 1-99,999Ω in 1Ω steps. Kit £10.8.0. Assembled £14.8.0.

**DECADE CAPACITOR**, Model DC-1U range, 100µF to 0.111 µF in 100 µF steps. Kit £7.5.0. Assembled £10.8.0.

**FULL RANGE OF MODELS IN  
FREE CATALOGUE  
SIMPLY SEND COUPON BELOW TO  
Dept. PM, Gloucester**

## Kits for Hi-Fi, Audio, Radios, Miscellaneous construction kits

**"MALVERN" HI-FI EQUIPMENT CABINET**. Will house all your Hi-fi equipment. Left "in the white." Size 39 1/2 x 32 x 21 1/2 in. Kit £18.1.0 (inc. P.T.). A wide range of other cabinets.

**HI-FI/FM TUNER**. Range 88-108 Mc/s. Available in two units, sold separately. **TUNER (FMT-4U)** 10.7 Mc/s IF £2.15.0 (inc. P.T.). **IF AMPLIFIER (FMA-4U)** power supply and valves £13.13.0. Total Kit £16.8.0.

**JUNIOR ELECTRONIC WORKSHOP**, Model EW-1. 20 exciting experiments can be made. Special solderless connections. Kit £7.13.6 (inc. P.T.)

**TRANSISTOR MIXER**. TM-1. A must for the tape enthusiast. 4 inputs, 9 v. battery operation. Kit £11.16.6. Assembled £16.17.6. All prices quoted are mail order.

**"OXFORD" LUXURY TRANSISTOR PORTABLE**, Model UXR-2. Beautiful solid leather case. LW and MW. Coverage. Kit £14.18.0 (inc. P.T.)

**GENERAL COVERAGE RECEIVER**. Model RG-1. Freq. coverage 600 kc/s-1.5 Mc/s. 1.7-32 Mc/s in 6 switched bands. Many features incl. 1/2 lattice crystal filter. Kit £39.16.0. Assembled £53.0.0.

**6W QUALITY STEREO AMPLIFIER**. Model S-33H. An inexpensive stereo/mono amplifier. Ideal for use with the Decca Deram lightweight pickup. Modern attractive styling. Kit £15.17.6. Assembled £21.7.6.

**STARMAKER-33 TRANSISTOR PA/Guitar AMPLIFIER**. Full 20 watts (33 watts IHFM) output. Four inputs on two channels. Two heavy duty speakers. Compact size. Tremolo. Elegant cabinet. Kit £44.19.0. Assembled £59.10.0, legs or castors extra.

**TRANSISTOR GENERAL COVERAGE RECEIVER**, Model GC-1U. Frequency coverage 580 kc/s—30 Mc/s in 5 bands. Kit £37.17.6. Assembled £45.17.6.

**20 + 20W TRANSISTOR AMPLIFIER**, Model AA-22U. Outstanding performance for price. Send for full spec. Kit £39.10.0, less cabinet. Beautiful cabinet £2.5.0 extra.

**The Berkeley SPEAKER SYSTEM**. New construction gives faster assembly. Professionally styled walnut finished cabinet. 2 speakers cover 30 c/s—17,000 c/s. Only 7 1/2" deep x 26" h x 17" wide. Kit £18.18.0. Assembled £23.0.0.

**SSU-1 SPEAKER SYSTEM**. A practical solution to the problem of a low-price speaker system. Two speakers. (Bookcase) £11.17.6 Kit (inc. P.T.) (With legs) £12.12.0 Kit (inc. P.T.)

## See the complete Heathkit range in the FREE catalogue



HI-FI CABINETS



QUALITY STEREO and MONO AMPLIFIERS



TRANSISTOR PORTABLES



SW RECEIVERS TRANSMITTERS



FM & AM/FM RADIO TUNERS

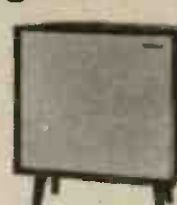

SPEAKER SYSTEMS

Welcome To Our  
LONDON HEATHKIT CENTRE

233 Tottenham Court Road

We open MON.-SAT. 9 a.m.-5.30 p.m.  
THURS. 11 a.m.-2.30 p.m.

Telephone: MUSEUM 7349

WHEN YOU ARE IN TOWN, WE HOPE  
THAT YOU WILL VISIT US THERE

To DAYSTROM LTD., DEPT. PM-6, GLOUCESTER, ENGLAND

Please send me FREE BRITISH CATALOGUE (Yes/No).....

Full details of model(s).....

American  
Catalogue 1/- p.p.  
(Yes/No).....

NAME  
(BLOCK CAPITALS)  
ADDRESS.....

PM-6

# IMPROVED STANDARDS of Accuracy and Reliability!

Modern styling in light grey with legible black engraving.

Constructed to withstand adverse climatic conditions.

Ever ready case including leads, prods and clips.

Improved internal assemblies.

Re-styled scale plate for easy, rapid reading. 2 basic scales each 2.5 inches in length.

New standards of accuracy using an individually calibrated scale plate: d.c. ranges 2.25% of full scale deflection, a.c. ranges 2.75% of full scale deflection.

Available accessories include a 2,500V d.c. multiplier and 5, 10 and 25A shunts for d.c. current measurement.



The Mk. 4 MULTIMINOR is the latest version of this famous Avo instrument and supersedes all previous models. It is styled on modern lines, with new high standards of accuracy, improved internal assemblies, and incorporating panclimatic properties.

The instrument is supplied in an attractive black carrying case, which also houses a pair of leads with interchangeable prods and clips, and an instruction booklet. It is packed in an attractive display carton. Robust real leather cases are available, if required, in two sizes, one to take the instrument with leads, clips and prods, and the other to house these and also a high voltage multiplier, and a d.c. shunt.

D.C. Current: 100 $\mu$ A f.s.d. — 1A f.s.d. in 5 ranges.  
A.C. Voltage: 10V f.s.d. — 1,000 f.s.d. in 5 ranges.  
D.C. Voltage: 2.5V f.s.d. — 1,000 f.s.d. in 6 ranges.  
D.C. Millivolt ranges 0 — 100mV f.s.d.

RESISTANCE: 0-2M  $\Omega$  in 2 ranges, using 1.5V cell.  
SENSITIVITY: 10,000  $\Omega/V$  on d.c. Voltage ranges.  
1,000  $\Omega/V$  on a.c. Voltage ranges.



## MULTIMINOR Mk 4

See the latest AVO  
Electrical Testing Instruments  
on STAND G60  
I.E.A. Exhibition, Olympia.

Please note new address:

**AVO LTD**

ARCHCLIFFE ROAD, DOVER, KENT

Telephone: Dover 2626



MM17

### LOOK! AT OUR PRICES

GERMANIUM RECTIFIERS  
GJ7M 24v  $\frac{1}{2}$  amp 24/- Doz.  
or 2/6 each + 6d. postage Postage 1/-

MAT TRANSISTORS  
Mat 101 and 121 8/6 each  
Mat 100 and 120 7/9 each

MINIATURE GERMANIUM  
DIODES P. & P. 6d. 6/- Doz.

BY100 SILICON RECTIFIERS 65/- Doz.  
800v. P.I.V. 500mA  
or 7/- each + 4d. post. Postage 1/-

SILICON RECTIFIERS 7/6  
800v. P.I.V. 5 amp. P. & P. 4d.

TANK AERIALS  
6 Section. Total Length 10' 10".  
Perfect for Vertical Aerial or Fishing  
Rod. 10/6 each 1/6 P. & P.

VEROBOARD Now in Stock  
2 $\frac{1}{2}$ " x 5" 3/8 2 $\frac{1}{2}$ " x 3 $\frac{3}{4}$ " 3/-  
3 $\frac{3}{8}$ " x 5" 5/2 3 $\frac{3}{8}$ " x 3 $\frac{3}{8}$ " 3/8  
Postage 6d. each extra.

TRANSISTOR HOLDERS 11/6 Doz.  
3 or 5 Pin Type  
1/- each + 4d. postage Postage 6d.

This Month's Special  
OC71 TRANSISTORS 2/6 each  
or 27/6 Doz. P. & P. 6d.

PETHERICK'S RADIO SUPPLIES  
Dept. C  
22 HIGH STREET, BIDEFORD, N. Devon  
Tel.: Bideford 3217

### TRANSISTORS FOR TECHNICAL COLLEGES

This book will be of particular value to students of electronic engineering in all types of Technical College. With its practical approach it will also serve as an elementary design text for the many industrial engineers

by L. Barnes, M.Sc.Tech., A.M.I.E.E. 25/- Postage 1/-

ABC'S OF SILICON CONTROLLED RECTIFIERS by A. Lytel. 16/- Postage 1/-

1966 WORLD RADIO TV HANDBOOK. 28/- Postage 1/-

INSTRUCTIONS IN ELECTRONICS by C. N. G. Matthews. 15/- Postage 1/-

COLOUR TELEVISION EXPLAINED by W. A. Holm. 21/- Postage 1/-

TRANSISTOR ELECTRONIC ORGANS FOR THE AMATEUR by A. Douglas & S. Astley. 18/- Postage 1/-

TAPE RECORDER SERVICING MANUAL by H. W. Hellyer. 63/- Postage 2/-

TRANSISTOR POCKET BOOK by R. G. Hibberd. 25/- Postage 1/-

COMPLETE CATALOGUE 1/-

### THE MODERN BOOK CO.

BRITAIN'S LARGEST STOCKISTS  
British and American Technical Books

19-21 PRAED STREET  
LONDON, W.2

Phone: PADdington 4185

Open 6 days 9-6 p.m.

### CRESCENT RADIO LTD.

40 MAYES ROAD  
WOOD GREEN, N.22

London's Electronic Centre  
Quality Components For The Home Constructor

#### AERIALS

Combined ITA/BBC  
Room, Loft, Outdoor, etc.  
24/- 29/- 57/6.  
625 Aerials from 31/6.

#### AERIAL COAX

Air Spaced 6d. Yd.  
Low Loss 9d. Yd.  
625 Special 1/2 & 1/8 Yd.

#### TRANSISTOR COMPONENTS

Miniature Electrolytics  
Wide Selection from 1/3.  
Resistors all values  
 $\frac{1}{8}$  watt 4d. each.  $\frac{1}{4}$  watt 3d.  
Hi Stab. from 6d. each  
Miniature Tuners & Vol. Controls  
Keen Prices

#### VALVES & TRANSISTORS

Our stocks are too numerous to list so  
Send 6d. for Catalogue

EVERYTHING ELECTRICAL  
IN A FRIENDLY ATMOSPHERE

# THE SEMICONDUCTOR . . .

## PART 3. PNP JUNCTION TRANSISTORS

BY CHARLES NORMAN

IN THE FIRST article of this series we discussed the rectifying action of a *pn* junction. Basically, a transistor is a device with two such junctions, one of which controls the current through the other. Although the effect is approximately the same as that of a valve, the control mechanism is completely different.

A germanium *pn*p transistor consists of two layers of *p*-type germanium separated by a much thinner layer of *n*-type material. Once this arrangement and the theory of the current flow is understood, transistors should present no problems.

### BASIC CONFIGURATION

Fig. 1 shows the circuit diagram of a typical transistor amplifier. It could be the a.f. stage of a receiver, for instance. It has three connections: one is fed via a load resistor from a low voltage supply; one is supplied via a potential divider with a much lower voltage; the other is led through a resistor to "ground". If we use batteries to represent the voltage supplies, omit the resistors and replace the transistor circuit symbol with a diagrammatic section of the device, the effective circuit is that shown in Fig. 2. Now we can compare the transistor configuration with that of a normal triode shown in Fig. 3.

The triode too has three connections, one of which is connected to ground, one to a high voltage supply, and one to a lower voltage. In this respect at least the circuits are similar.

The upper electrode of the transistor, which seems to correspond to the triode anode, is called the collector. The centre, or thin section, which from its

position in the circuit should be analogous to the grid of a valve, is called the base. The lower section takes the place of the valve cathode and is called the emitter.

Some differences in the nature of the two devices will become obvious when we examine the direction in which the voltages are applied. The base bias, which is usually termed  $V_{bb}$ , makes the base negative with respect to the emitter. Bearing in mind that a *pn* junction is a rectifier in which the effective direction of electron flow is from *n* to *p*, this means that a steady current,  $I_b$ , flows in the base circuit. In other words, the base-emitter junction is forward biased. The collector supply,  $V_{cc}$ , makes the collector negative with respect to both base and emitter. So the collector-base junction is reverse biased.

In a valve the anode-cathode circuit is forward biased by the h.t. supply while the grid is reverse biased in opposition to the electron flow from cathode to anode.

### PRACTICAL EXPERIMENT

Before going into the theory it might be helpful to connect up a transistor and see how it responds to the applied voltages. Make up the circuit of Fig. 4, using any low power germanium *pn*p transistor. The principles are the same whatever the type number used because all transistors in the same group behave in a similar manner. Since this is merely a quick experiment there is no point at this stage in making an elaborate construction job. Just make the necessary connections and then get to work on the experiment.

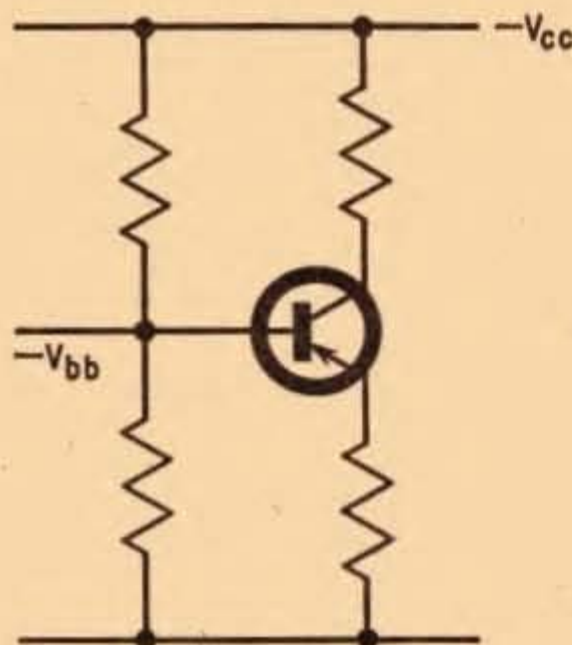

Fig. 1. Basic grounded emitter configuration of a *pn*p transistor

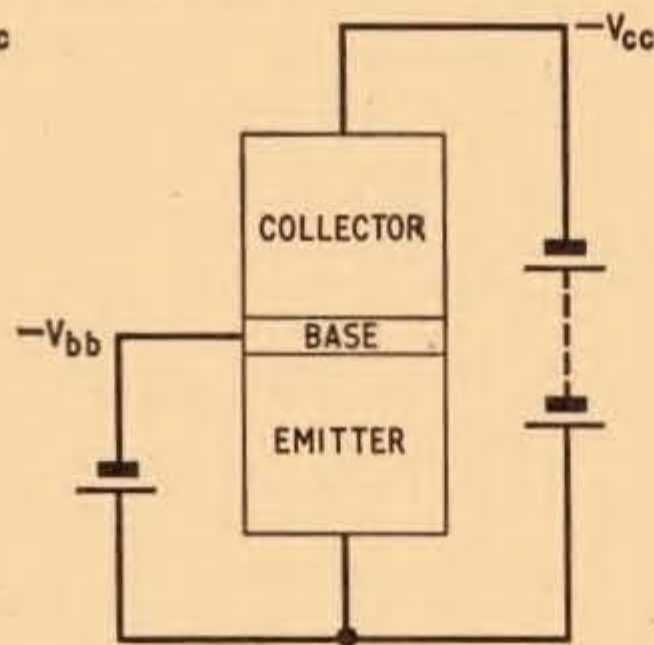

Fig. 2. Diagrammatic section of a *pn*p transistor with power supplies connected

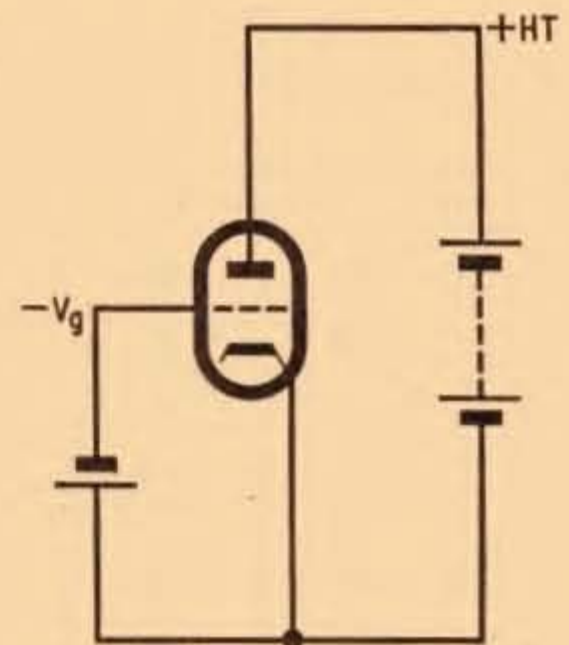

Fig. 3. Basic triode configuration with power supplies connected

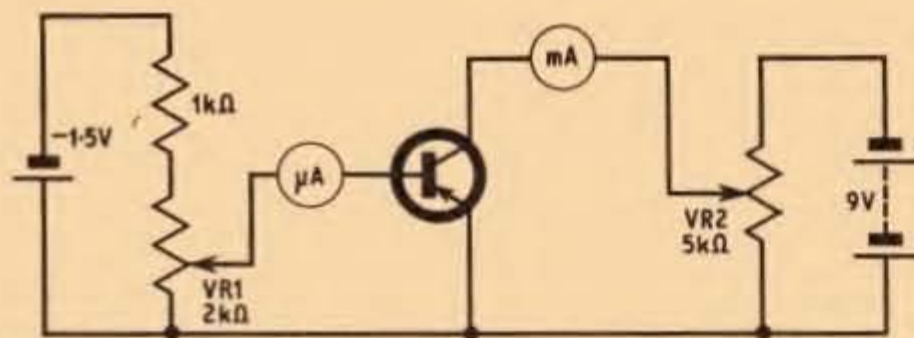

Fig. 4. Experimental circuit to determine current gain

Start with both potentiometers at the lower end so that no voltage is applied either to collector or base. Then slowly turn up the collector supply potentiometer till nearly 9 volts is applied to the collector. You should see virtually no current indication on the collector current meter. If the needle flicks over or if there is anything like a substantial current then you have either chosen a faulty transistor or the collector supply polarity is incorrect. By starting at zero potential you minimise the likelihood of damage due to mistakes.

Now begin to turn up the base voltage. You will notice that as base current begins to flow the collector begins to draw current. Further, while the base current can be measured in microamps, the collector current is in the order of milliamps. The ratio between changes in the two will be about 50 to 1 depending on the current gain of the transistor used. For instance, if the base current increases by 10 microamps the collector current will increase by approximately 500 microamps or 0.5mA.

Once you have satisfied yourself on these points try varying the collector supply voltage. It will have some effect on the collector current but nowhere near so much in proportion as the base voltage. On the other hand, you will find that a small change in base voltage causes an appreciable change in base current.

### CHARACTERISTICS

From this experiment we can draw the following conclusions:

1. Base voltage has a greater effect than collector voltage on collector current. In this respect the transistor behaves like a valve.

2. The output impedance of a transistor must be high because a change in collector volts has a relatively small effect on collector current. This too is similar to a valve.

3. The input impedance of a transistor is low because the input current changes readily with base voltage. This is directly opposite to valve behaviour.

4. Unlike a valve, the input circuit is biased so that the equivalent of a steady grid current flows.

5. Changes in input current produce much larger changes in output current. So the transistor acts as a current amplifier.

6. Because the input of a transistor draws current it must put a load on the circuit preceding it. Consequently, the signal operating a transistor amplifier must supply power whereas, under ideal conditions, a valve draws no power at all from the signal which operates it. This is the really big difference between valves and transistors.

### THEORY

Having established these points by experiment, we can now set about deducing the theoretical reasons for them. To do this we need to consider the behaviour of the electrons and holes in the three layers

of the transistor. Fig. 5, which shows the distribution of the current carriers, should help.

In the case of a *pnp* transistor the current will be a movement of electrons. The physical thickness of the base may be as little as 0.0005 inches. In the thicker layers of *p*-type germanium which comprise collector and emitter the current will be carried by holes.

Since holes are positive, the base bias  $V_{bb}$  tends to move them in the direction shown. At the base-emitter junction some of the holes are filled by electrons from the negative pole of the battery. The positive battery pole attracts electrons from the far end of the emitter, thus creating more holes. These move from positive to negative towards the base. Because the base is so small, it cannot conduct sufficient electrons to fill all of the holes. So, in addition to the steady flow of electrons,  $I_b$ , we get a concentration of holes on the emitter side of the base-emitter junction.

The collector voltage,  $V_{cc}$ , is connected in opposition to the rectifying collector base junction and can only have a limited effect on the movement of current either as holes or electrons. Some of the holes will be "filled" in the collector and attract more electrons to the collector end remote from the collector-base junction. This produces a shortage of holes, which of course is equivalent to a surplus of electrons, close to the junction.

Thus, on one side of the microscopically thin base layer we have a surplus of electrons and on the other side we have a concentration of holes. Under these conditions only one thing can happen. The electrons shoot through the thin barrier and fill the holes. This continues for as long as the base bias maintains the concentration of holes at the base-emitter junction and the collector voltage keeps up the shortage of holes in the collector. So a steady collector current flows.

The base layer is so thin that it cannot conduct sufficient electrons to fill more than about 1 in 50 of the concentration of holes that its potential draws to the junction. The remainder are filled by electrons from the collector. On the other hand, unless the base bias maintains a concentration of holes at the base-emitter junction, there are no holes for the collector's surplus electrons to fill and no collector current can flow.

Since for every hole filled by a base electron 50 are filled by collector electrons the collector current is 50 times as great as the base current. So a small change in base current will be magnified 50 times in the collector. This current amplification is called

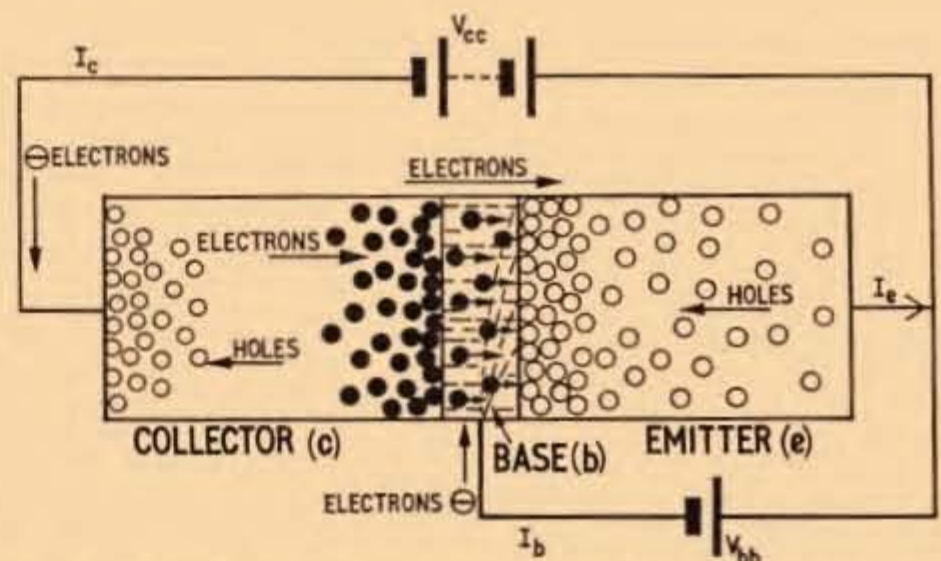

Fig. 5. Distribution of current carriers (*pnp* transistor)

the current gain of the transistor sometimes referred to as  $\beta$  or  $\alpha'$ . Recent improvements in manufacturing techniques have produced transistors with betas of well over 100, but it is true to say that the average transistor has a beta in the region of 50.

### VOLTAGE GAIN

So far, so good! We can use a transistor to amplify a current change. But how do we achieve a voltage gain? Theoretically, we need only to include a load in series with the collector and take off the voltage variations across this. Let us see if this is practicable.

Make up the circuit of Fig. 6. This is identical with Fig. 4 except that a collector load resistor has been added and we measure voltages instead of currents.

With the base potential set to zero the collector voltmeter will indicate 9 volts. This means that the transistor is cut off, which is consistent with the theory we have just discussed. As you increase the base voltage the collector voltage will begin to fall. This shows that the collector is drawing a current and a potential difference is produced across the load.

The exact results will depend to some extent on the transistor you are using, but by varying the base over a small fraction of a volt, you should be able to vary the collector voltage over a few volts. Collector voltage will continue to fall as you increase the base bias but with the circuit values shown it should be impossible to turn on the transistor to the extent of causing damage. A collector load of about 10 kilohms should limit the collector current to less than 1 milliamp.

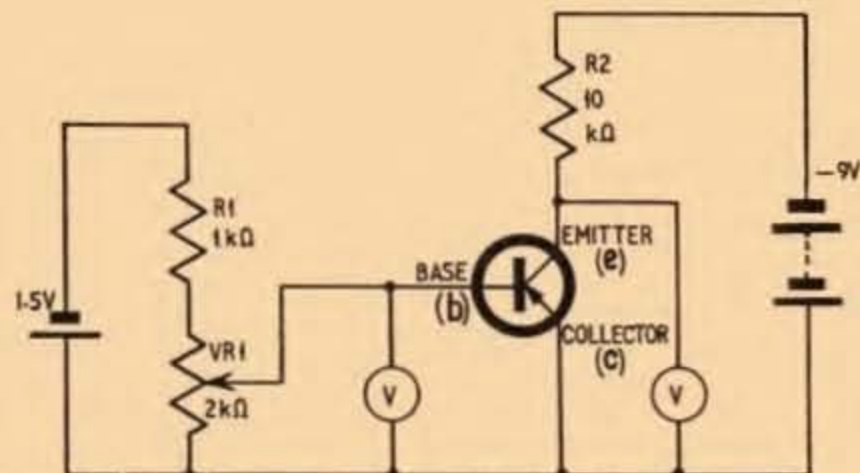

Fig. 6. Experimental circuit to determine voltage gain

Use the base control to set the collector voltage at, say, 2 volts. Now measure the amount by which the base voltage must be reduced to increase the collector voltage to 7 volts. This will be in the order of 0.025 volts. Looking at this from an a.c. point of view it seems that a signal of 0.025 volts peak to peak would give an output of 5 volts peak to peak. So this circuit has a theoretical voltage gain of 200, which is not unreasonable.

It is safe to say that you will get a result of this order because the beta of most transistors in common use is about 50. As they all have a fairly high output impedance and a fairly low input impedance the performance of one transistor at low frequencies is very like that of another. At higher frequencies additional factors must be taken into consideration.

Next month, in the concluding article of this series, we will discuss more practical circuits. ★

## Your 124-Page Guide to Better Motoring at Less Cost

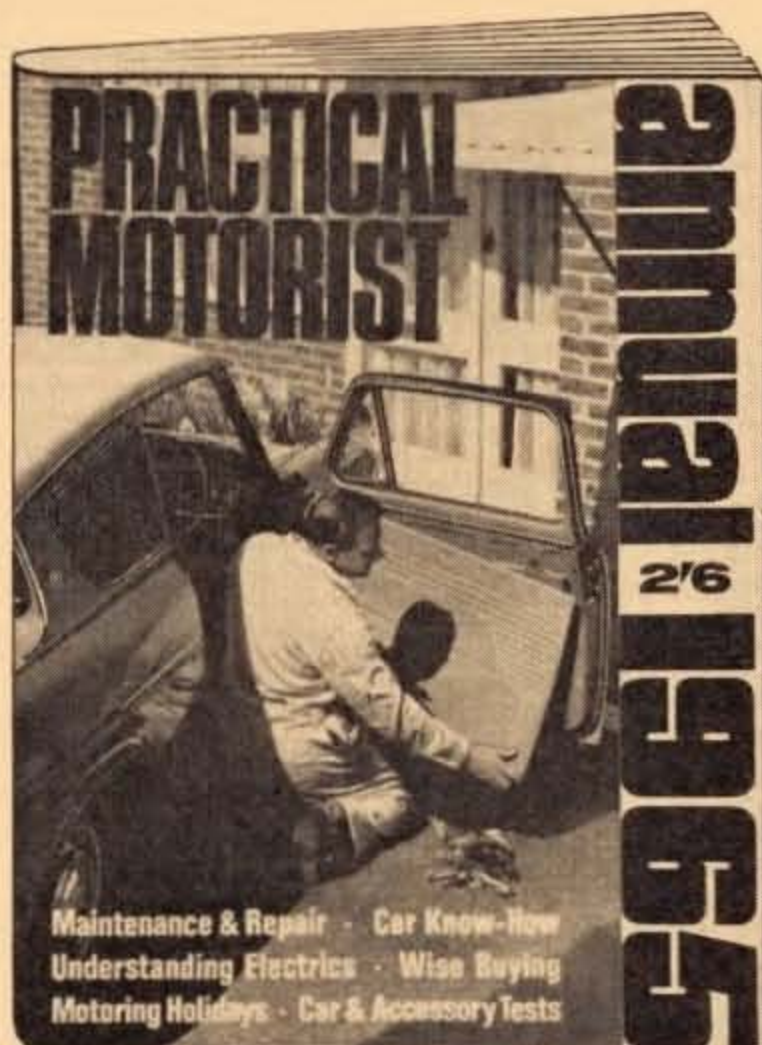

OUT MARCH 29TH

# PRACTICAL MOTORIST annual 1965

Sections on:—

MAINTENANCE AND REPAIR  
CAR KNOW-HOW  
UNDERSTANDING CAR ELECTRICS  
BUYING A CAR  
TOURING HOLIDAYS  
RUNNING A WORKSHOP  
CAR AND ACCESSORY TESTS

Performance Analyses of a variety of Popular Models

BIG DEMAND! RESERVE YOUR COPY NOW—2/6

# ELECTRONIC BUILDING BLOCKS



## PART ONE

by R. A. DARLEY

ANY piece of electronic equipment, no matter how simple or complex its design, can be broken down into a number of basic electronic "building blocks". All readers will, no doubt, be familiar with the type of "block diagram" shown in Fig. 1.1. This particular drawing depicts the functional layout of a conventional superhet receiver and, as can be seen, shows that the receiver consists of the following building blocks suitably arranged: r.f. amplifier, mixer, oscillator, i.f. amplifiers, detector, a.f. amplifier, power amplifier, and loudspeaker.

Once the principles of each of the above building blocks has been grasped, it becomes simplicity itself to understand the working of the complete superhet. By the same token, the intricacies of any piece of equipment are easily grasped if the basic building blocks employed are understood and, similarly, a designer must have a wide knowledge of all electronic building blocks if he is to develop a new piece of equipment to carry out a particular function.

It is the object of this series to lay before the reader the essential details of most of the basic building blocks in use at the present time. Basic functional and design details will be outlined in easily understood terms; a non-mathematical approach to the subject will be maintained, and in many cases practical circuits for the experimenter will be given.

The first part of this series is devoted to introducing the reader to some of the building blocks that will be described in more detail in subsequent issues.

### SIMPLE ATTENUATOR

As the name implies, this circuit is used to give an output which is smaller than the input by a predetermined amount, but of the same general form. An example of this circuit is the volume control. In this case the precise amount of attenuation is of little importance and the control is not calibrated. In many cases the precise amount of attenuation will be of great importance, and the resistive values will have to be chosen with great care. The circuit shown in Fig. 1.2 gives an attenuation of 10 (or -20dB) the upper resistor being made 9 times as great as the lower one.

### BRIDGE

A variation of the simple attenuator circuit is the basic resistance bridge. It can be seen from Fig. 1.3 that this circuit consists of two attenuator or voltage divider networks, with a common supply. The output is taken from between the two centre resistance junc-

tions. If the *ratios* of the two dividers are the same, there will be zero voltage difference between the junctions. If the ratio of only one divider ( $R_3 : R_4$ , for example) is known, and the value of only one of the resistors in the other divider is known and the circuit gives zero voltage difference at the junction, the value of the fourth resistor can be calculated. This principle is used in the well known Wheatstone measuring bridge. By using reactive, instead of resistive, components in the dividers, the circuit can be used to measure values of capacitance, inductance, frequency or phase shift.

### PASSIVE ADDING OR MIXING NETWORKS

The simple resistive network shown in Fig. 1.4 enables voltages to be added together without effecting or loading one another. The output is smaller than, but directly proportional to, the sum of the inputs. The circuit may be used for addition in an analogue computer, or as a mixing network.

### FILTERS

As the reader will realise, filters are devices which enable one narrow band of frequencies to be selected from all others (such as in high pass or low pass networks), but the scope of this subject is so vast that it will be possible to discuss it only very briefly in this series.

### DIFFERENTIATING CIRCUITS

These consist of a resistor and a capacitor as shown in Fig. 1.5. Also shown is the effect that the circuit may have on a square-wave fed into it. The waveshape is considerably altered. The "decay" time of the modified waveform can be calculated from the component values chosen, one of the most valuable properties of the circuit being that it contains an inherent time constant. This time constant is one of the most important and useful properties in electronics. It may be used, for instance, as a wave shaper. It also presents one of the limiting factors in amplifier frequency response.

### DISCRIMINATING DIODE

It can be seen from the diagram for the differentiating circuit that, if a square wave is fed in, the output waveform has a positive and a negative "spike". In many cases only one of these spikes will be required; by wiring the diode as shown in Fig. 1.6, the negative spike will be virtually eliminated, i.e. the diode enables the circuit to discriminate between positive and negative voltages. If required, the diode can be reversed and the other spike rejected instead. This circuit is often used in direct reading frequency meters.



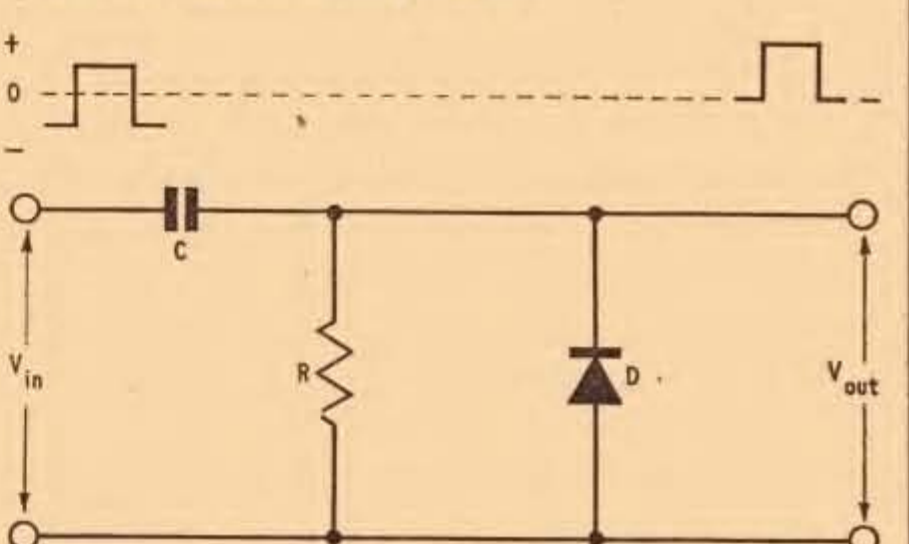
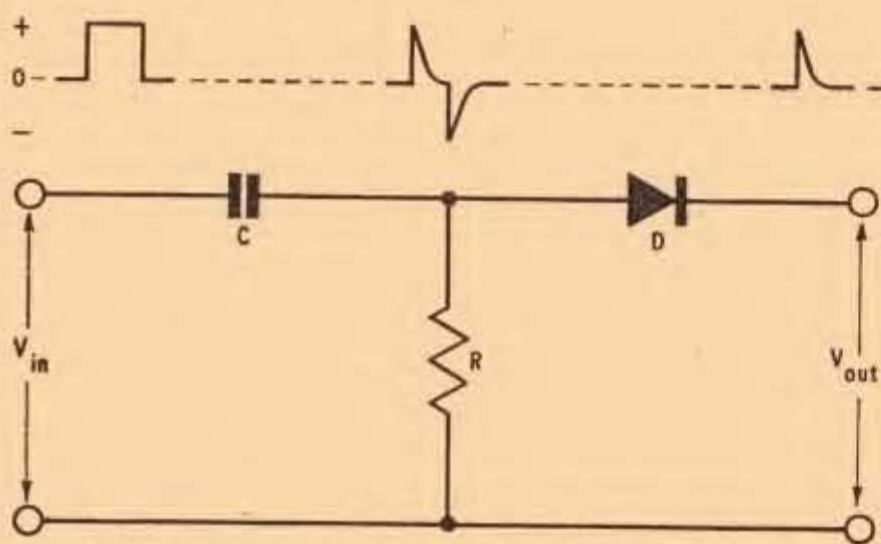
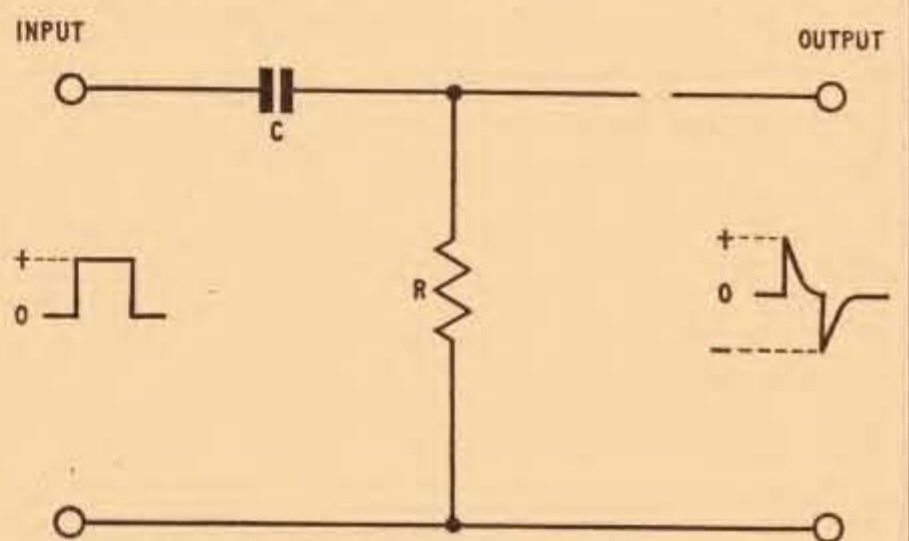
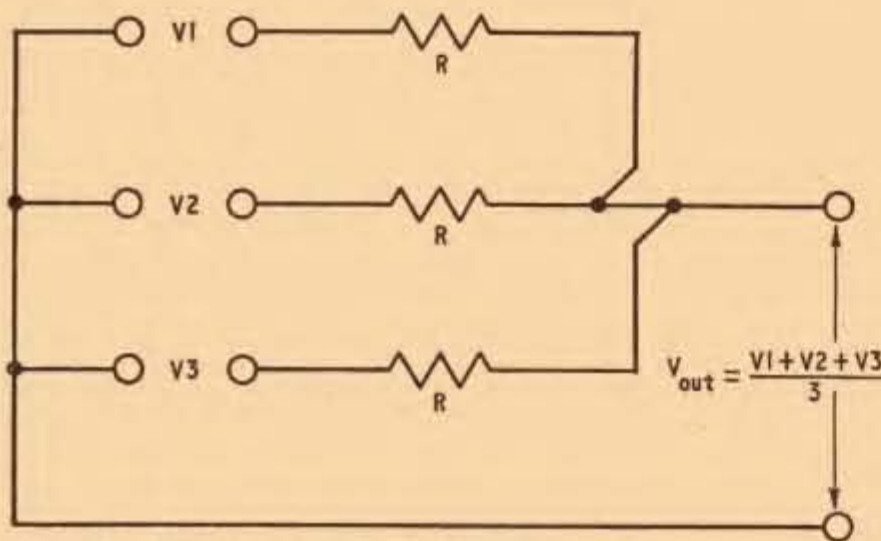
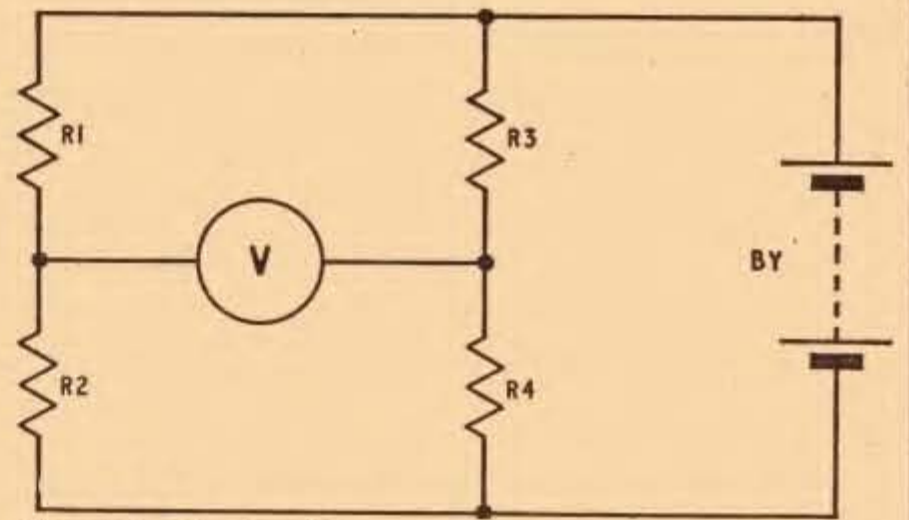
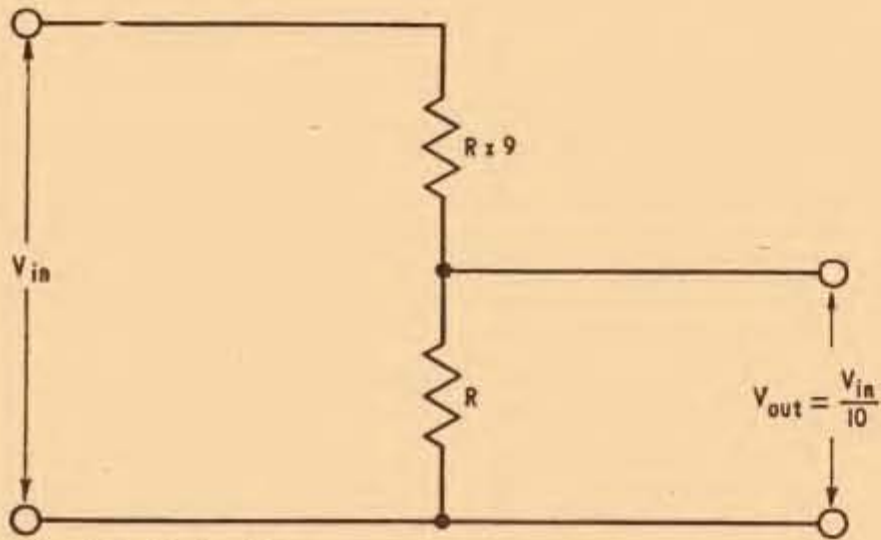
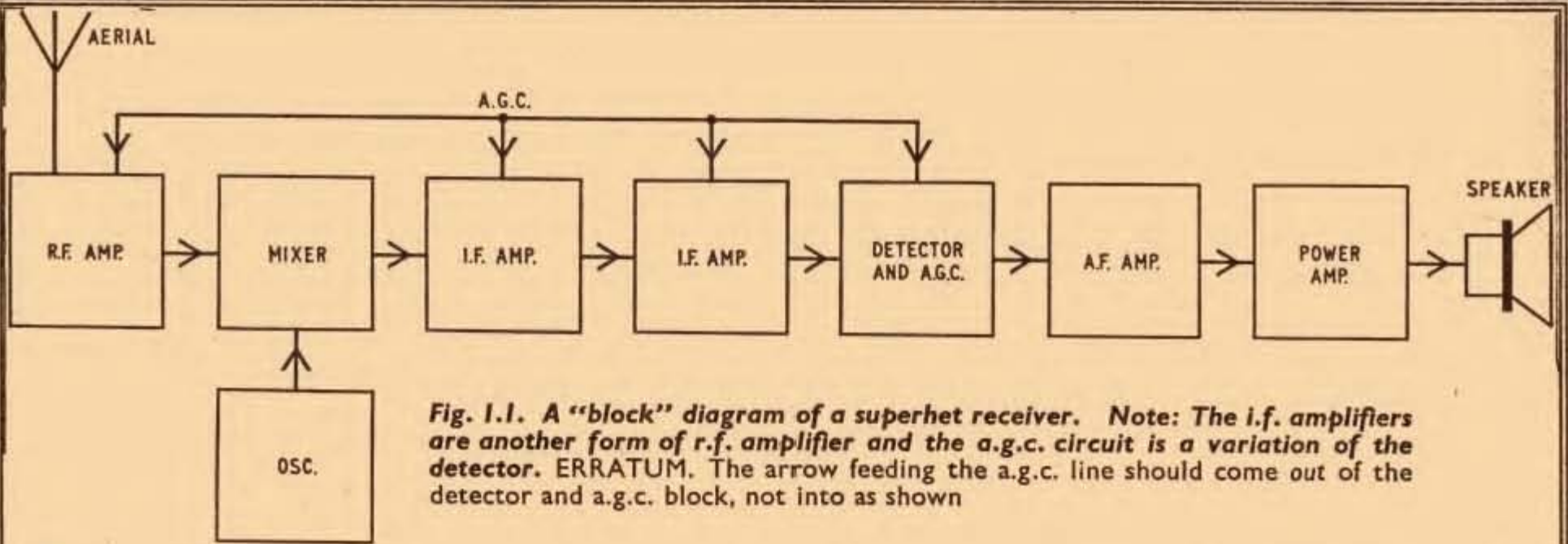

## CLAMPING DIODE

If a rectangular waveform, which varies above and below the zero voltage point, is fed into the circuit, as shown in Fig. 1.7, the output will be of similar form and amplitude (if component values are suitably chosen) but will vary only in a positive direction. The diode serves to "clamp" the output to the zero reference point. The diode can be reversed if required, in which case the output will vary only in a negative direction.

## DIODE LIMITING AND CLIPPING

If a sine wave is fed into the circuit shown in Fig. 1.8a, the diode will have the effect of clipping off all the negative half cycles and passing only the positive ones. This is, of course, the action of a conventional rectifier. If the positions of the diode and resistor are transposed, as in Fig. 1.8b, all the positive half cycles will be rejected and the negative ones passed.

## DIODE GATE

One of several types of gate, the AND gate, is shown in Fig. 1.9. This type of gate may have several inputs, but only one output; an output is available only when *all* inputs are applied. Another gate circuit, known as the OR gate, has several inputs and only one output, the output being available whenever any input is applied. Two other widely used gates are the NOT and the NOR types.

## AMPLIFIER

An amplifier may be put to many uses other than a.f., r.f., or power amplification. By employing a large degree of negative feedback, for example, any desired degree of gain can be accurately and reliably obtained, making the amplifier suitable for use as a mathematical multiplier. The block diagram of such an amplifier is shown in Fig. 1.10.

## IMPEDANCE CONVERTER

It is often necessary to change the impedance in one part of a circuit prior to reaching the next stage. For example, it may be necessary to feed the output of an oscillator to a low impedance attenuator, but direct coupling would upset the working of the oscillator. The use of an impedance converter between the two stages will overcome this difficulty. The best known device of this kind is the emitter follower circuit, an example of which is shown in Fig. 1.11. This is the transistorised version of the well known cathode follower valve circuit. Both of these circuits have a high input impedance and a low output impedance, with a stage gain of almost unity.

## PHASE SPLITTER

It is often required that two outputs, each out of phase with the other by 180 degrees should be available from a single input. In this case the device known as the phase splitter is called for, an example of which is shown in Fig. 1.12.

## LONG-TAILED PAIR

This circuit may be arranged to give a number of different functions. If required, it can be made to operate as a phase splitter, fed from a single input. Alternatively, it can be fed from two inputs, giving an output which is proportional to the difference between these two inputs (see Fig. 1.13). The circuit can thus be used in an analogue computer to carry out subtraction functions.

## IMPEDANCE AMPLIFIERS

One of the drawbacks of the transistor is that it has a very low input impedance compared with the valve. To overcome this, it has been necessary to develop impedance amplifying circuits in recent years. Two of these are illustrated in Fig. 1.14. That shown in Fig. 1.14a is known as the bootstrap amplifier. In many cases it is found that, while the single transistor circuit shown gives the required high input impedance, the overall frequency response of the circuit is inadequate; complex correcting networks have to be employed to correct this fault, with the result that the complete bootstrap amplifier may contain as many as four transistors.

Fig. 1.14b illustrates the circuit known as the Darlington pair or super-alpha pair. It is possible, with both of the circuits shown, to obtain input impedances of several megohms with little difficulty.

## SINE WAVE OSCILLATOR

Broadly speaking, these devices can be broken down into two basic types: audio frequency and radio frequency oscillators. Each of these types can be subjected to further breakdown into a vast range of sub-divisions. Some oscillators can be tuned by a voltage change instead of an actual component value change.

## SAWTOOTH OSCILLATOR

Another type of oscillator is that which generates a sawtooth waveform. This type is generally used to supply the time base for cathode ray tube displays. Some types give an output that can be controlled by an externally applied potential, and can thus be used to provide a time base for wobulators.

## "STAIR-CASE" GENERATORS

Yet another kind of generator is that which generates a sawtooth waveform which rises in a series of distinct steps rather than in a linear fashion. Such a device may be used as a time base generator for a transistor characteristics curve tracing oscilloscope, each step representing a particular test voltage or current.

A variation of this circuit is the "diode pump", in which the stair-case waveform is obtained from externally applied rectangular pulses. Such a device can be arranged as a counting or frequency measuring circuit.

## BLOCKING OSCILLATOR

Another type of oscillator circuit is that known as the blocking oscillator, an example of which is shown in Fig. 1.15. This circuit can be arranged to perform in a number of different ways. It can, for example, give a regular series of bursts of oscillation, or large magnitude pulses of very short duration, triggered from an external source.

## ASTABLE MULTIVIBRATOR

This is a two-state circuit, in which either the first transistor is on and the second transistor off, or the first transistor is off and the second on (see Fig. 1.16). The circuit will be in first one state, then the other, changing state of its own accord. The circuit is thus said to be "free running". If an output is taken from one of the collectors, it will have a rectangular waveform. The period between one change of state and the other is determined by the values of the coupling capacitors and resistive networks.

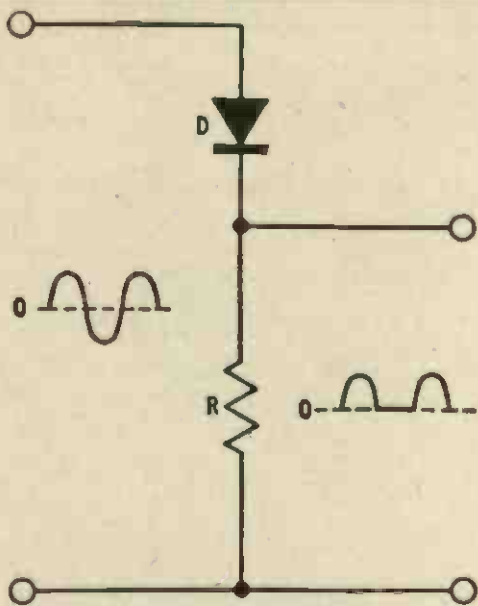

Fig. 1.8a. Diode limiter, negative part of signal clipped

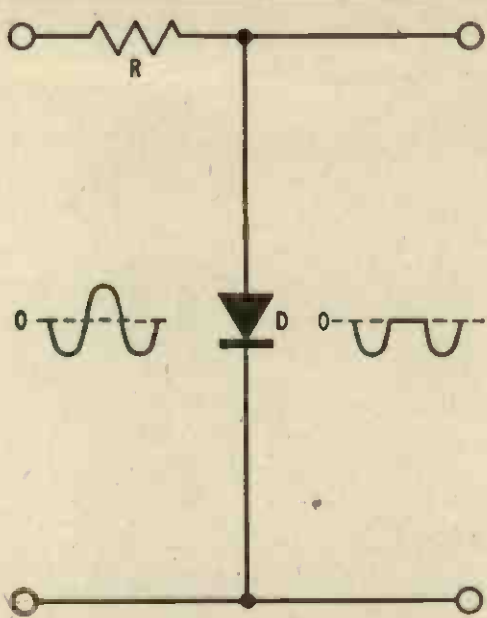

Fig. 1.8b. Diode limiter or clipper, positive part of signal clipped

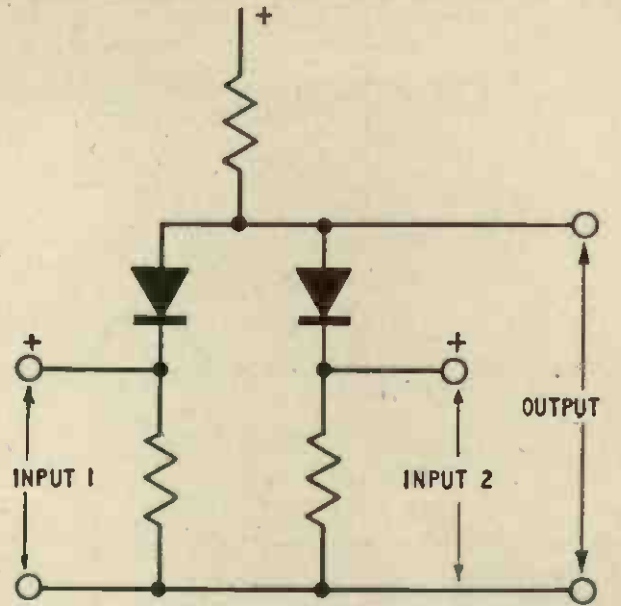

Fig. 1.9. An "AND" gate

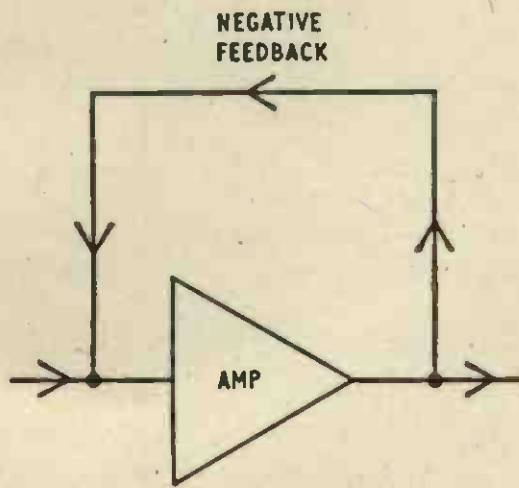

Fig. 1.10. A "block" diagram of amplifier with negative feedback

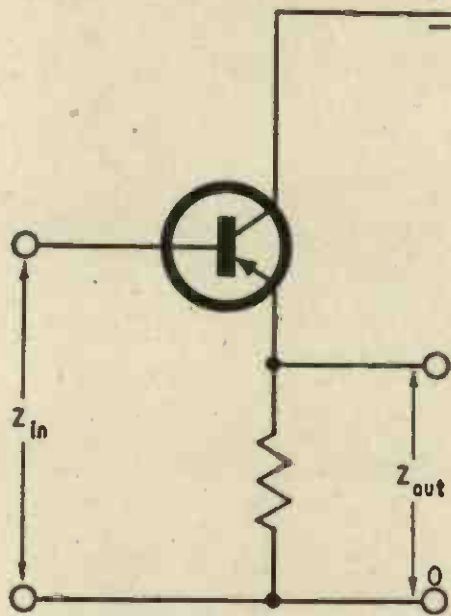

Fig. 1.11. Emitter follower impedance converter

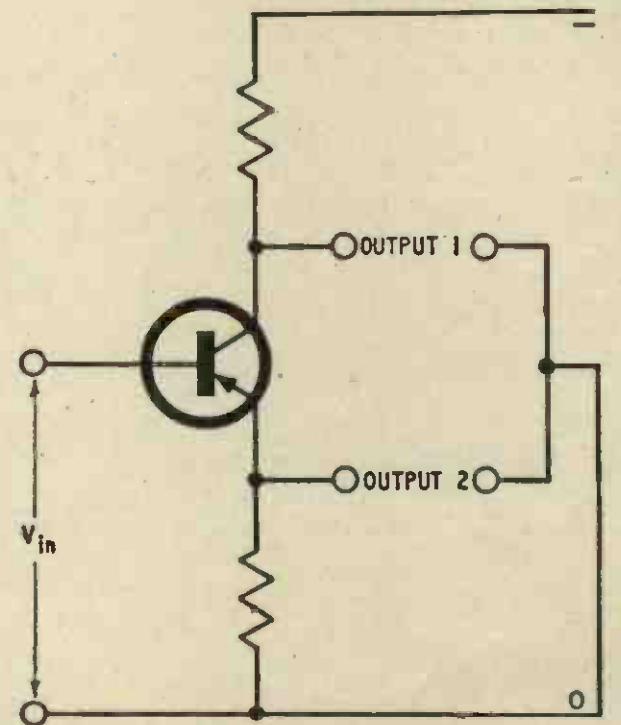

Fig. 1.12. Phase splitter

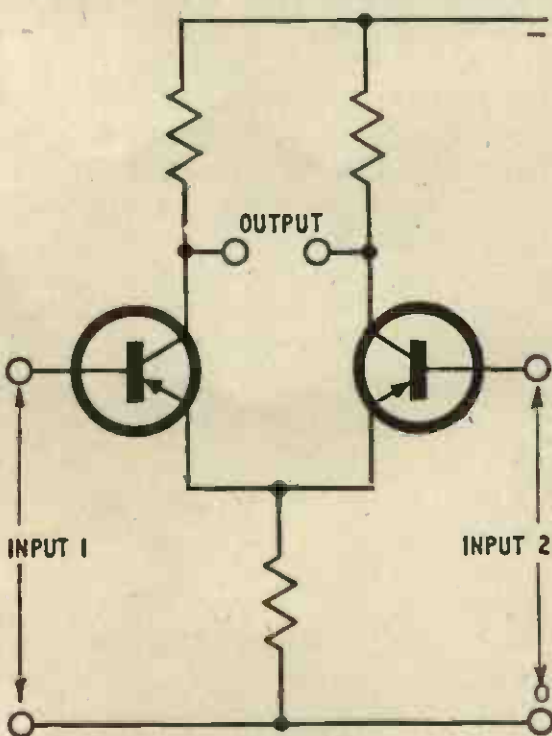

Fig. 1.13. Long tailed pair

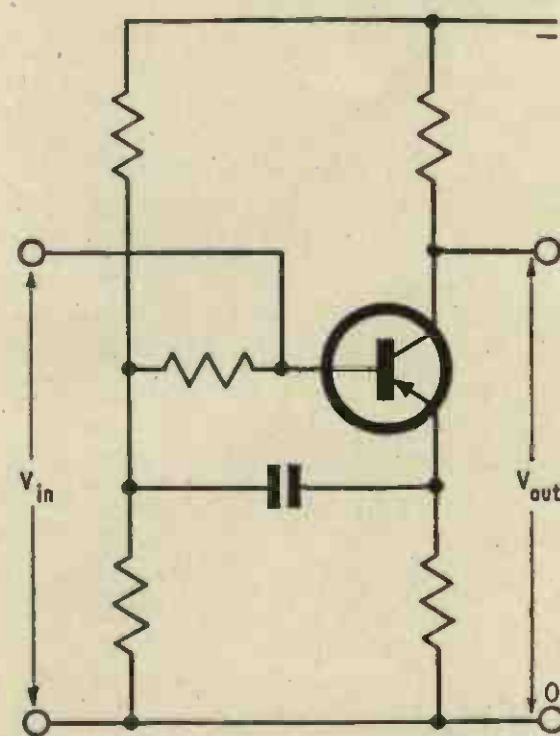

Fig. 1.14a. Basic "bootstrap" impedance amplifier

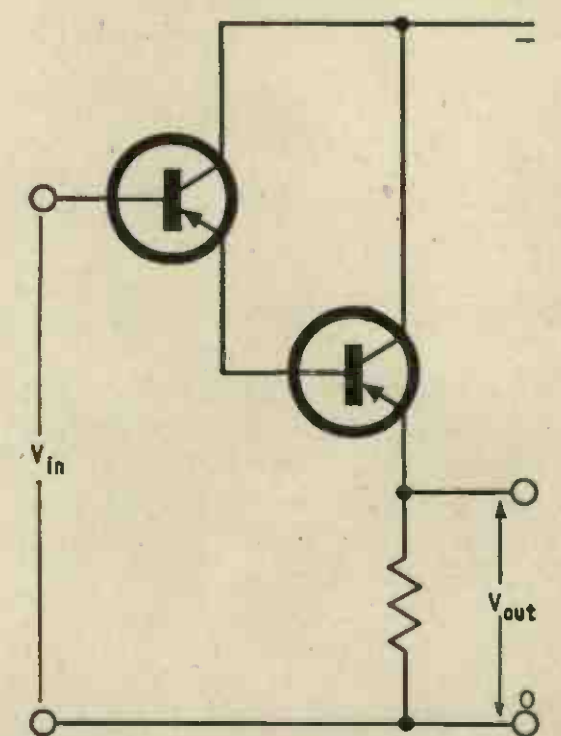

Fig. 1.14b. Basic "Darlington" or "super-alpha" pair impedance amplifier

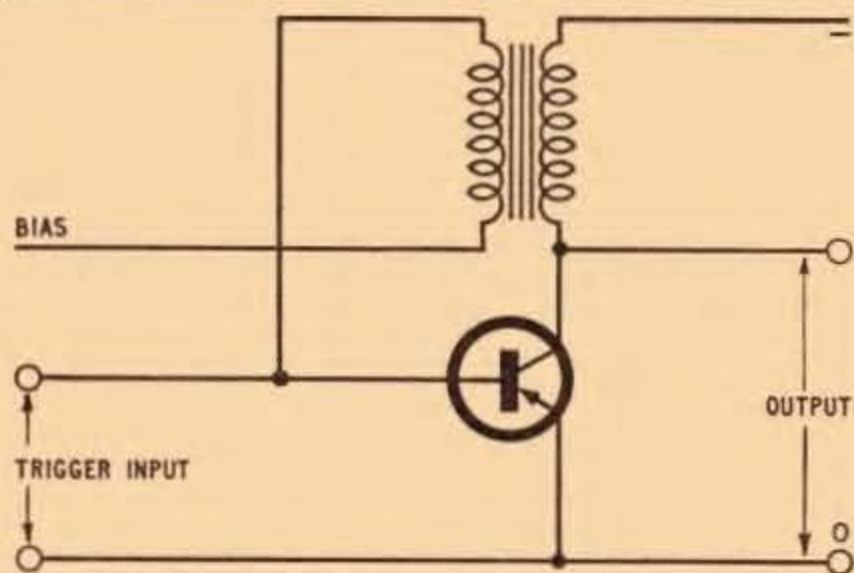

Fig. 1.15. Blocking oscillator

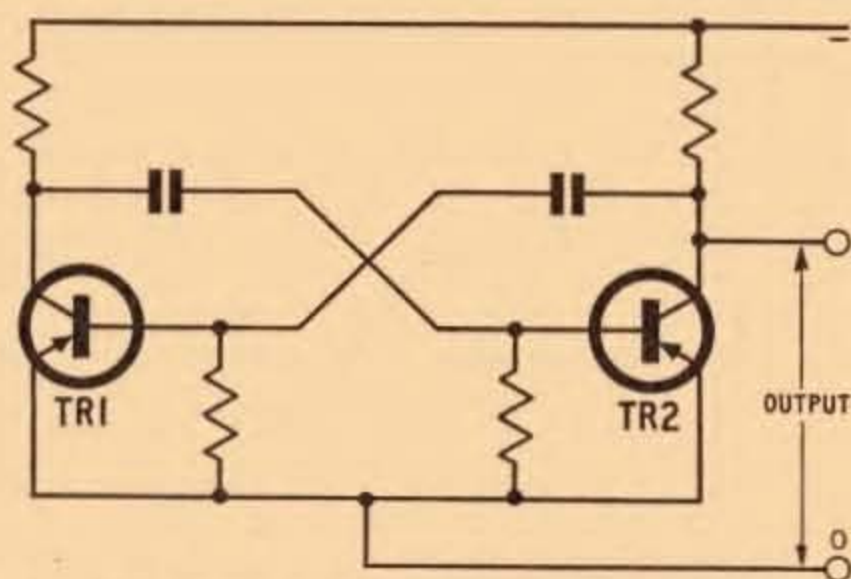

Fig. 1.16. An astable or free running multivibrator

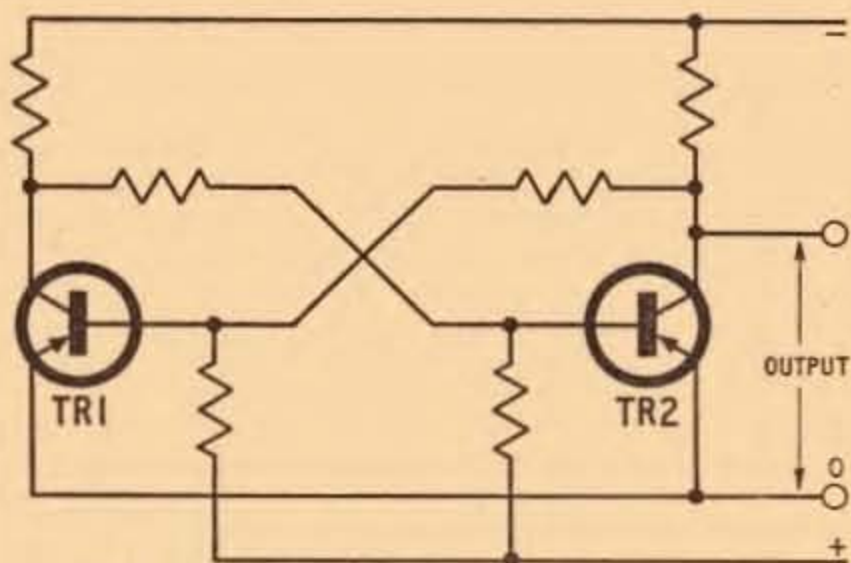

Fig. 1.17. A bistable multivibrator

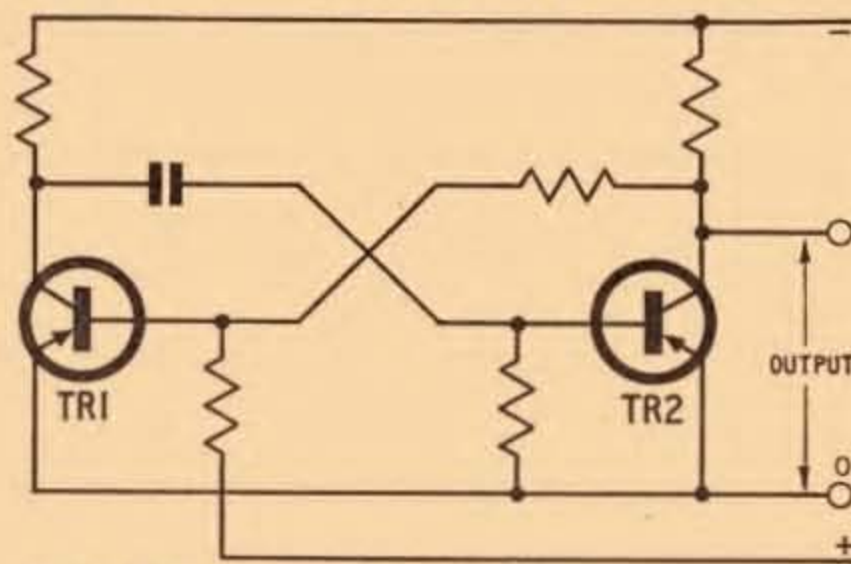

Fig. 1.18. A monostable multivibrator

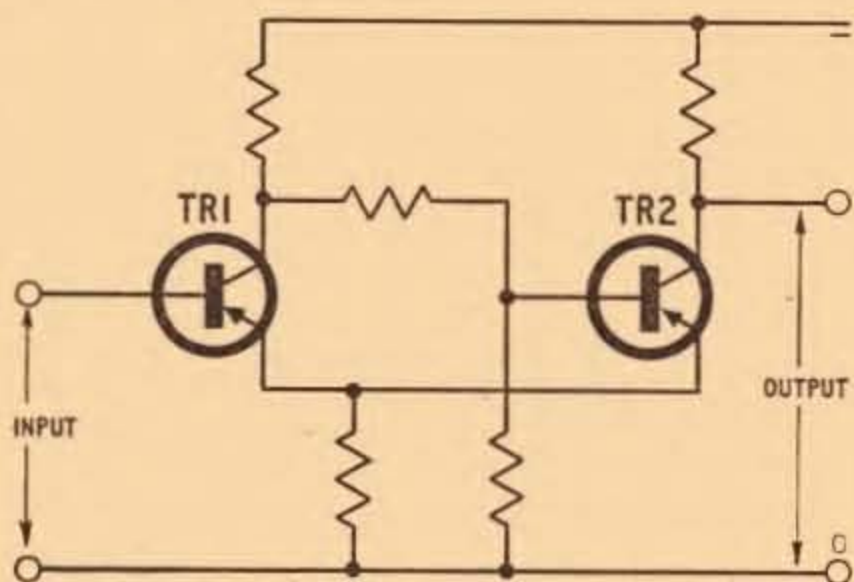

Fig. 1.19. A Schmitt trigger

### BISTABLE MULTIVIBRATOR

This again is a two-state device, but in this case it is not free running (see Fig. 1.17). The change from one state to the other must be activated by an externally applied pulse or signal. Two input pulses are necessary in order to cause a complete cycle of changes of state, resulting in only a single output pulse. The circuit thus divides by two, and is known as a binary divider.

### MONOSTABLE MULTIVIBRATOR

This third member of the multivibrator family is a combination of the other two (see Fig. 1.18). It has one stable and one semi-stable state. To cause a change from one state to the other, an external pulse must be

applied, as in the case of the bistable multivibrator, but after a predetermined time the circuit will again revert to its first state, as in the case of the astable multivibrator.

### SCHMITT TRIGGER

This is yet another two-state device, but in this case the state depends on the input voltage level. In its normal state, TR1 will be off and TR2 on (see Fig. 1.19). If the voltage is now applied to the input and slowly raised in amplitude, a point will be reached where TR1 will suddenly switch on and TR2 switch off. This condition will be maintained as long as the input voltage is not reduced below the "trigger" level. If the voltage is so reduced, the circuit will switch sharply back to its former condition. One of the many uses of this circuit is that of producing a square wave from a sine wave input.

### OTHER CIRCUITS

As well as the basic building blocks that have been briefly mentioned in this article so far, many other types also exist. In the field of mathematically operating circuits, for example, alternative circuits can be used for addition, subtraction, multiplication, division, differentiation and integration, as well as circuits which follow square or square-root laws.

This concludes our initial survey of the subject of building blocks. Detailed treatment of the various types of circuit mentioned will be given during the course of this series.

# DETACHED PARTICLES

By John Valence

## CRYSTAL BALL

**T**HE early months of the year seem to be particularly propitious for the crystal gazers. From among a flood of predictions concerning the social and scientific changes that are likely to descend on us (with beneficial results, of course!) in the not too distant future—I note just two or three.

Data transmission by teleprinter network is a field where one can expect continuing growth. In the United States computer grid systems are already in operation. At the present time it is possible to make connection with a computer at Massachusetts Institute of Technology from anywhere in the United States. Such is the potential development of these computer networks that the American Telephone and Telegraph Company estimates that by 1970 more revenue will be received from the transmission of computer data than from ordinary telephone conversations.

## HUMANS FIRST!

**D**o I detect a hidden danger here? Will this suggestion of lucrative business tempt our own G.P.O. to concentrate heavily in this direction to the detriment of the ordinary (would-be) subscriber?

Those long suffering members of the public who are still trying to speak to their fellow-men cannot be expected to enthuse over the news that machine can talk to machine from one end of the country to the other. We humans must exert our rights you know!

The year: the same. The scene: the United States as before.

After all the dire warnings of unemployment resulting from the widespread use of computers and automatic processes, it is comforting (to some of us at any rate) to read that in the very birthplace of automation itself, it is now forecast that 30,000 additional journalists will be required by 1970.

News—the unpredictable goings-on in the world brought about chiefly by erratic unprogrammed humans—will still need human gatherers and recorders.

## RUSH HOUR

**F**OR a final peep into the future let us come back home, where we find London Transport looking even further ahead. According to an official of this body, by the year 2,000 we can expect an almost completely automatic Underground. Just one man per train and one man per station. Trains and passengers alike will be controlled by magnetic fields, the first by magnetic pick-up coils, the second by means of metallic coated tickets which will permit entry or exit via automatic gates.

It will be just my luck to lose my ticket and then discover that the solitary custodian of the station has gone off for his tea.

Perhaps a slight disappointment for Londoners: the Wellsian scene with moving pavements and high speed monorail systems is not to be expected by the end of the present century. Don't know about you, but I can't afford to wait much longer than that!

## ALL CHANGE

**I**F a decision is taken shortly to change our currency over to a decimal system, much will have been due to the recommendations of the electronics industry.

As we all know the question of a decimal system has been under careful investigation for the past few years. All the signs are that despite some stubborn resistance to any such radical change by some individuals and a few organisations, the majority of informed opinion in the country strongly favours the adoption of some form of decimal currency.

Just recently the Economic Development Committee for the electronics industry added its voice to those in favour. The sale of computers overseas is often handicapped at present due to the need to produce two different models—one for the home currency in pounds, shillings and pence; the other for the decimal system which is almost universally in use.

If any further weight of opinion was needed to swing the balance decisively one way or the other—then it is my guess that the vital computer industry has provided it.

## ELECTRA'S THE NAME

**W**E find nowadays various commercial and non-commercial organisations changing their names or modifying them to include some reference to electronics.

The Electrical Trades Union is one of the latest organisations to decide that a more with-it title is desirable. True they have delved back into Greek mythology and adopted the name of a Trojan War leader's daughter—Electra. But still very apt, I think, for this is obtained from the abbreviated form of the proposed full title—which is Electrical, Electronics and Communication Trades Association.

By the way, it comes to mind that a lady of the same name is oft seen in the Thames estuary waters. The lady in this case is a launch owned by the Marconi Company and used as a practical showroom for marine radio and radar equipment.

A final thought. Electra slaving over a hot open stove all those hundreds of years ago could not, despite her name, have had any premonition of the labour-saving kitchen of today. But we must be careful. The housewife of 1980 will probably recall, as she pops a programme with complete menu for the evening meal into her electronic cooker prior to setting off on a day's jaunt, just how tied down her mother was way back in the 50's and 60's.



*Frankly, mother, he doesn't think much of today's programme*

# MAGIC BOXES

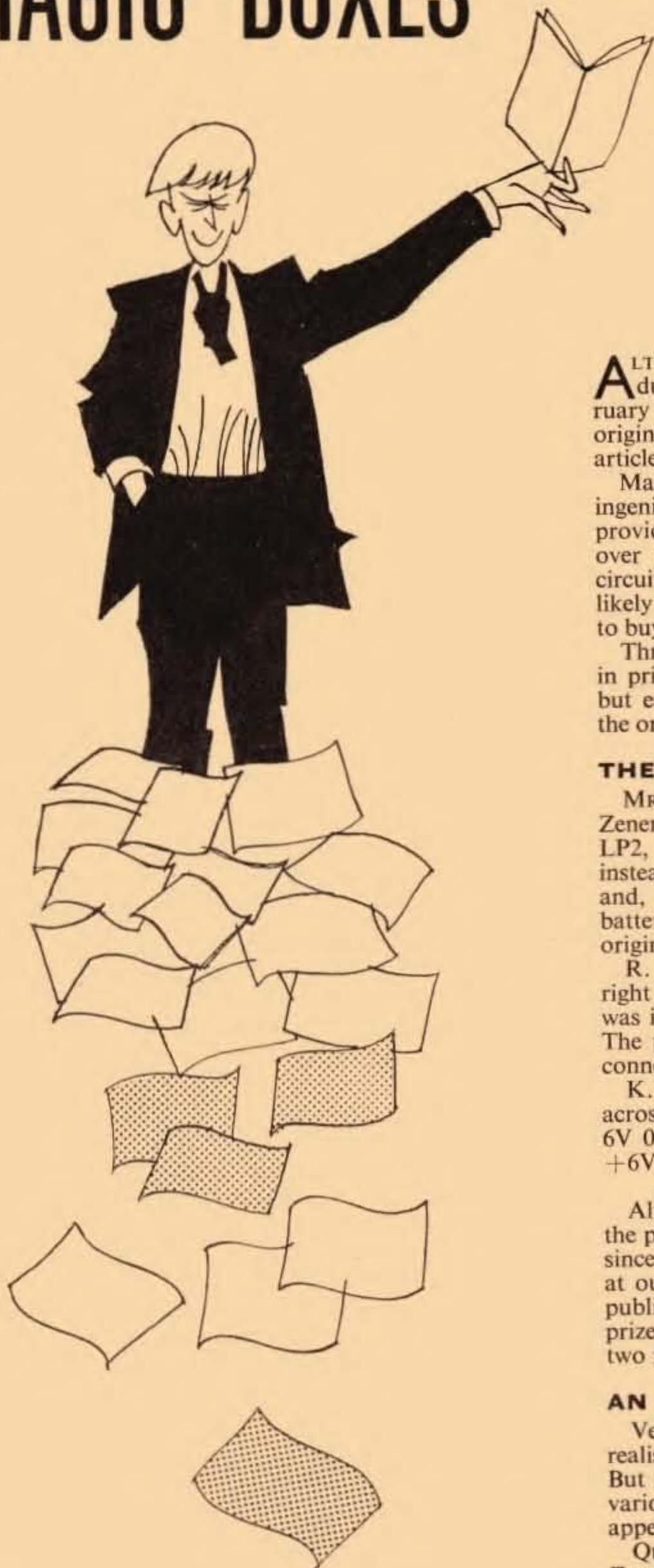

*Ingenuity  
Unlimited!*

**A**LTHOUGH over five hundred solutions were sent in during the week following publication of our February issue, no one provided an exact duplicate of our original circuit as shown in Fig. 2 of last month's article "Magic Boxes".

Many and varied were the circuits devised by our ingenious readers. Most of these would undoubtedly provide the required function, i.e. control of two lamps over a single pair of wires, but in many cases the circuits suggested were unduly complex, and indeed likely to provide exceedingly uneconomical if one had to buy all the components called for!

Three readers submitted circuits that were correct in principle and would perform entirely satisfactorily, but each of these differed in some minor detail from the original design explained below.

## THE WINNER

MR. C. W. JOLLY, HORNCHURCH, connected the Zener diode D1 across LP1 (green) instead of across LP2, and gave the rating of one lamp as 6.5V 0.02A instead of 6V 0.06A. His supply voltages were correct and, furthermore, by using only three taps on the battery, appears to have improved somewhat on the original design.

R. J. WARD, WARWICK, placed the Zener across the right lamp but with reversed polarity. A 9V supply was included but tapped at +7.5, +6, 0, and -1.5V. The polarity of the supply was in accord with Zener connection.

K. WILSON, OLDHAM, also connected the Zener across LP2 but in reverse. His lamps were rated at 6V 0.04A and 6V 0.3A, and the supply provided was +6V, -6V, and +12V.

Although these three were very close contenders for the prize, it was easy to declare C. W. Jolly the winner, since apart from being the first of this trio to arrive at our office, his answer does more closely match the published circuit than the other two. A consolation prize of one guinea has been awarded to each of these two runners-up.

## AN ABUNDANCE OF DIODES

Very hot on the trail were the thirty-odd readers who realised the secret lay in the use of a Zener diode. But alas, they were not content with only one, and various combinations of Zeners and ordinary diodes appeared.

Quite a few who had not seen the light concerning Zener breakdown put their trust and hope in the

common or garden diode—a single specimen, or any number up to five.

Most of the above mentioned arrangements would appear to work, but all certainly required more components than the original design.

### BY BATTERY ALONE

In the highly commended class come economically minded readers who eliminated diodes entirely. With three identical batteries, two lamps, and a three-way switch they almost got there: but not quite, for with this arrangement (see Fig. 1) no "off" position can be provided and therefore the lamp box is not completely under the control of the switch box. Furthermore, in the "Green and Red" position, the lamps glow with but half their normal brightness.

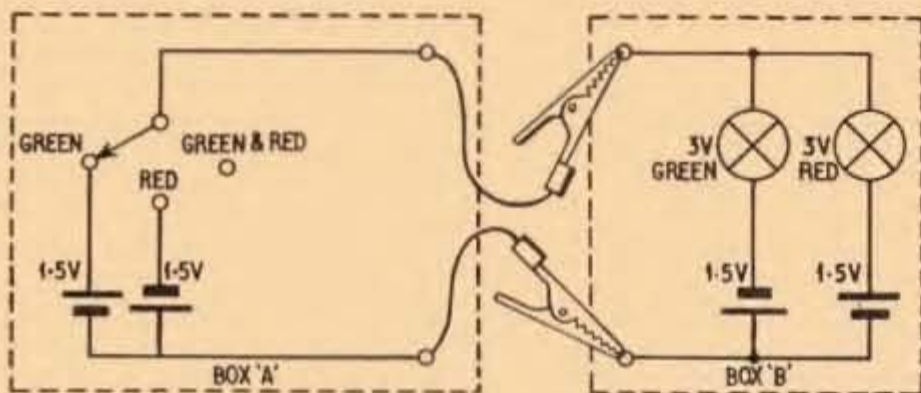

Fig. 1. This arrangement relies on all battery voltages being identical. Unfortunately this circuit will not permit both lamps to be extinguished at the same time

Perhaps a note should be added here to explain that while no "off" position was indicated in the published circuit, it is nevertheless quite practical to incorporate one if one substitutes a four-way switch for S1. In fact this has been carried out on the original model in our possession—see photographs.

### A.C. HELPS OF COURSE

Now to refer to the largest category of answers received. At least 180 readers stipulated an a.c. supply. This, they suggested, was to be fed in from some external source—despite the fact that no additional leads or connections were indicated in our photograph of the "Magic Boxes". Of course, once a.c. is permitted, the remainder is easy!

Most of this group voted for a pair of diodes in each box, connected up as shown in Fig. 2, although sometimes the diodes would be in parallel with the lamps. The individualistic approach was also apparent: some used a battery for single lamp operation and a.c. for dual operation, while some used C and L filters in place of some of the diodes, and so on.

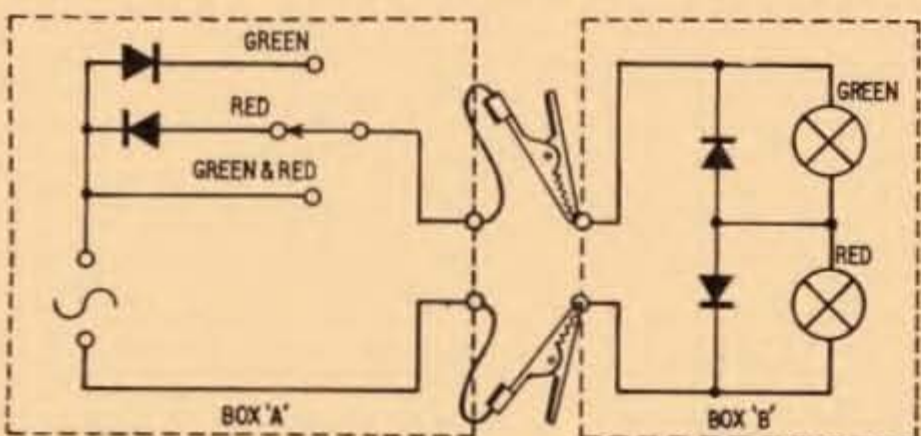

Fig. 2. No real problem if a.c. is allowed, as this typical circuit makes clear. Many variations of this idea are, of course, possible

An alternating or pulsating supply was very much in favour by another large group, of about 100—but these were independent characters who devised the means for generating the desired waveform *inside* the box. Much enterprise was shown here naturally. We had phase shift oscillators, valve and transistor multivibrators, electro-mechanical vibrators, binary counters, variable frequency oscillators—anyhow you name it, we have it!

Quite a few alert readers "appropriated" the transistor inverter circuit described in the previous page to that carrying the announcement of the "Magic Boxes". And some admitted it too!

[We will have to be more careful with our page arrangement in future—Editor.]

### RELAYS IN STRENGTH

The second largest group was composed of the relay devotees. Yes, we know you can do almost everything with relays, but what about the cost?—and don't forget the boxes are supposed to be quite portable. Perhaps you will forgive us if we were a trifle disappointed at this un-electronic approach!

Our spirits were restored however by the small band who suggested *bona fide* electronic means to achieve our end. These included transistors operated as on/off switches, and the humble neon also employed as an on/off device.

### MISCELLANY

You think we have about now exhausted all the ideas brought forward? Not in the least. However, it is possible to mention just one or two of the more unusual suggestions.

The problem imposed by the limitation to a pair of wires was tackled with some resolution it must be conceded. A third "wire" was conjured up by a few readers who made both boxes of metal. Unfortunately they completely overlooked the practical attribution of the "Magic Boxes" as a means of *remote* control.

Rather more subtle was the introduction of a screened lead as one connection; this involved a modification to the crocodile clip and an additional stud on Box B. Sorry, but that's cheating.

Oh yes, we did also get a pair of double-cored leads.

A Wheatstone bridge arrangement was suggested and looked feasible.

The adoption of a moving coil meter, so that its needle would act as a switch wiper arm making contact with various points according to the amount of current fed down the lines, appeared more than once.

Electro-mechanical engineering was well represented, quite a few ideas coming from model control enthusiasts we suspect. One of the more intriguing ideas in this department was a motor driven drum with metal segments which would produce three different kinds of signal according to speed and direction of rotation.

### THANK YOU ALL!

The circuits submitted often showed considerable attention to detail both technically and from a drafting point of view, with circuit values carefully worked out. Many circuits were accompanied by clear explanations of how the particular arrangement functioned.

Thanking all who participated in this little electronic exercise, we would emphasise that although the vast numbers involved make it impossible to acknowledge each entry individually, each idea submitted received careful scrutiny.



# ELECTRONORAMA

HIGHLIGHTS FROM THE CONTEMPORARY SCENE



## Traffic Control

by ARCH



**S**TACHUS SQUARE in Munich, believed to be the busiest traffic centre in Europe, is undergoing extensive rebuilding which will incorporate an electronic automatic traffic control system developed by Elliott Automation in conjunction with Signalban Huber K.G. of Germany. The heart of the system is an Elliott ARCH computer which will control the traffic flow by using up to the minute information provided by traffic conditions prevailing at the time.

When the rebuilding operations are complete, traffic will flow at four levels; two of these will be used by the underground railway, one for pedestrians and the fourth for motor traffic and public transport. It is planned to integrate the control of tramways with motor traffic by storing and using an abbreviated version of the tramway timetable in the computer. The system will cover the control of four neighbouring traffic centres and will optimise the traffic flow at them by comparing a series of fixed programmes with varying traffic densities.





## Solid State Cooking

**W**HAT is believed to be the world's first solid state cooker was exhibited by the Appliance Controls Branch of Smiths Clock and Watch Division at the Electrical Development Association Exhibition at Harrogate in February. The cooker controls are replaceable modules for one hotplate, three non-linear regulated hotplates, linear regulated grill, and meat probe. An oven thermostat and programming clock are also fitted.

All meals are said to cook perfectly and the oven is switched off automatically at the end of the cooking period. The control modules are powered from a 12 volt supply.

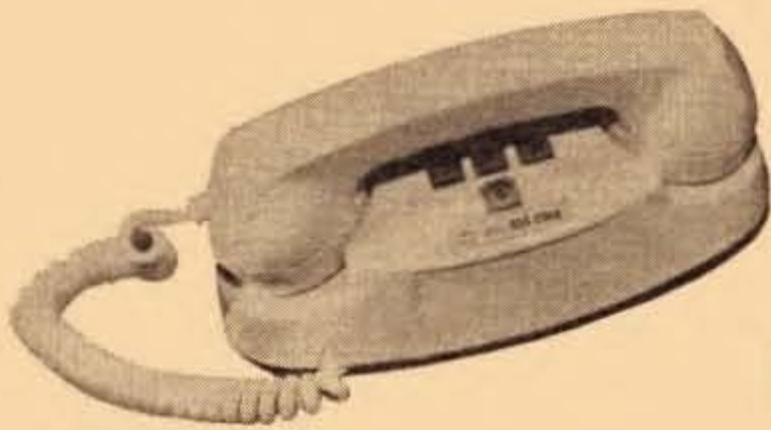

## Number Please!

**I**T LOOKS as if the telephone dial is on the way out at last. It seems to be a logical step in this push-button age to introduce push-button telephones. In fact, plans are under way in America to convert to a radically new system of subscriber calling although the order of letters and digits remain much the same as before.

It is expected that the new system will be operative throughout the U.S.A. (about 84½ million subscribers) within 10 years.

Tests have shown that it is more than twice as fast to "press out" a call than to dial. Furthermore it is claimed that this new method is easier and more accurate.

## Northern Lights

**A** WINDOWLESS channel electron multiplier will be used for the first time in experiments to map the electron density during an aurora—the event better known as the "Northern Lights". This new device, developed by Mullard, has been launched into space for the first experiment from Northern Norway. The multiplier is essentially an open ended glass tube with a high resistance coating on its inner surface.

When a voltage is applied between the ends of the tube the coating acts as a continuous dynode. Electrons are bounced off the coating at several random points. Secondary electrons are emitted from the resistive layer and drawn down the tube, each producing more secondary electrons when it strikes the tube wall. The cumulative effect is a cascade of electrons at the high potential end. With 5,000 volts between the ends of the tube and power consumption of only 0.2 milliwatt, the gain is of the order of a hundred million.

The device is much simpler and smaller than a conventional electron multiplier, which has separate dynodes each needing a different voltage supply. It is expected that the multiplier will be also used in mass spectrometry and ultra violet spectroscopy.

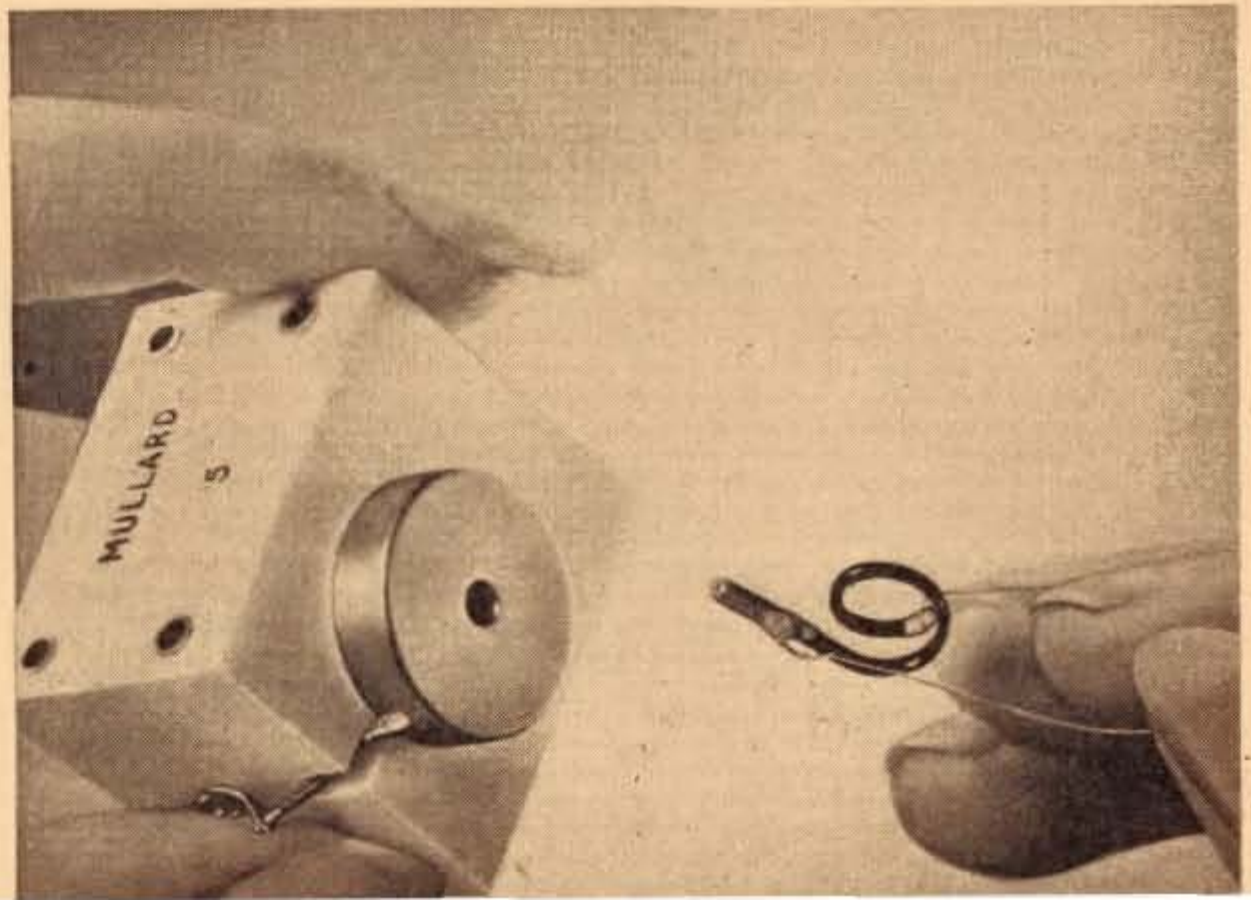

# BEGINNERS start here...

# 6

## An Instructional Series for the Newcomer to Electronics

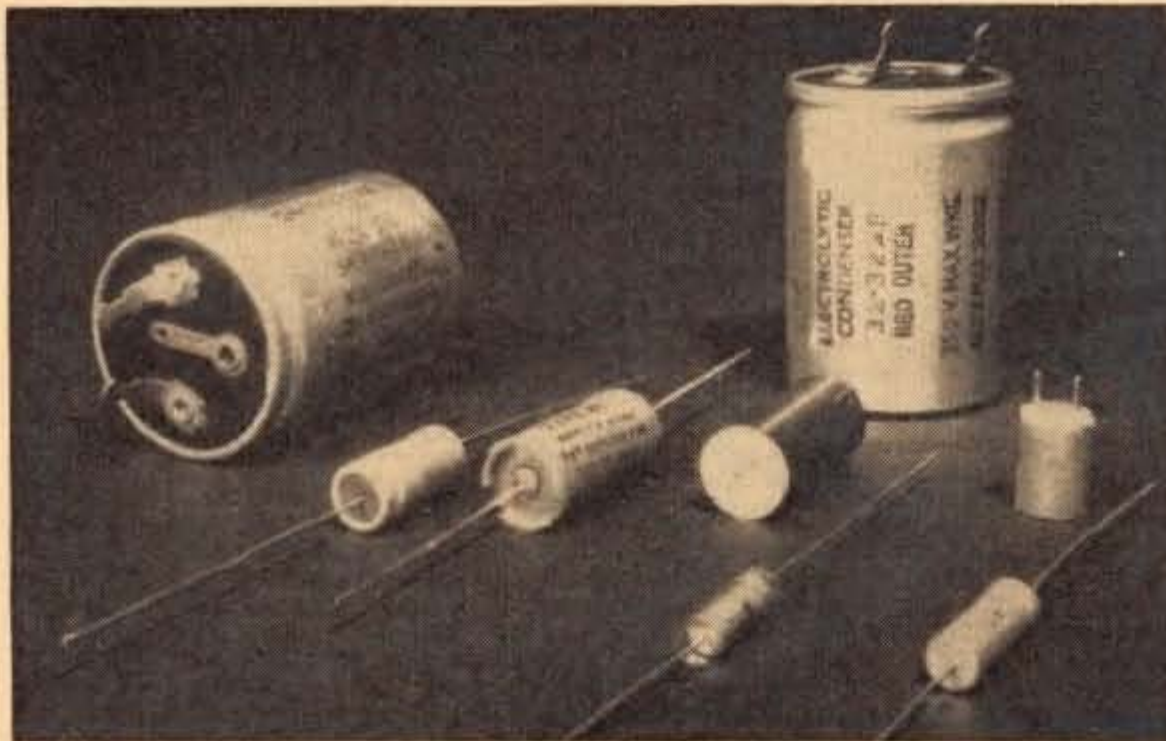

### ELECTROLYTIC CAPACITORS

Here is a representative group of electrolytics. The two large components are dual units and each incorporates two separate  $32\mu\text{F}$  350V working capacitors within the one metal can. The common negative connection is the centre tag.

The smaller components with lead-out wires have the following values and voltage ratings (reading left to right):  $100\mu\text{F}$ , 15V,  $50\mu\text{F}$  25V,  $15\mu\text{F}$  12V, and  $60\mu\text{F}$  10V.

A pair of plastic encased miniature capacitors specially designed for close packing on printed wiring boards are also shown. These have two pins emerging at one end. The larger one is  $300\mu\text{F}$  10V, the other  $25\mu\text{F}$  25V.

WE are all well aware of the desirability of getting a quart into a pint pot. It is now our purpose to explain how this has been achieved with capacitors.

Using any of the constructional methods described last month, we find that the component becomes very large and bulky as the value of capacitance increases. For values of say  $1\mu\text{F}$  and upwards, the physical size of a "paper" capacitor is often much too great for normal applications. This question of size is most important nowadays with the continuing trend towards miniaturisation in electronic devices.

Together with this demand for smaller and more compact circuit assemblies comes the demand for very large capacitance values (several hundreds of microfarads) due mainly to the special requirements of circuits based on transistors.

The electrolytic capacitor is no newcomer to the scene but modern production techniques have advanced so tremendously that there is now little problem in getting a quart into a thimble—speaking figuratively of course! Let us now look more closely at this component.

### ELECTROLYTIC CAPACITORS

Very high values of capacitance are achieved within modest volumes by replacing the normal solid dielectric with an insulating film formed by electrochemical action.

In the usual form of "dry" electrolytic capacitor construction, two electrodes of aluminium foil are separated by a paper foil which is impregnated with a chemical solution or paste. See Fig. 6.1.

When a d.c. potential is applied to the aluminium foil electrodes, a thin insulating film is formed on the surface of the electrode connected to the positive side of the supply. The large capacitance values realised are due to the extreme thinness of this film which acts as the dielectric between the two aluminium foils. This film has a high strength and can withstand voltages of up to about 600V.

The paper which carries the paste is fully conductive and therefore does not increase the effective thickness of the dielectric film in any way.

It should be noted that the so-called "dry" electrolytic is not in fact completely dry; this term is used to distinguish it from the earlier type of wet electrolytic which used a free liquid electrolyte.

Solid electrolyte aluminium foil capacitors—which are truly "dry" have been developed recently. These have a semiconductor material in place of the usual electrolyte.

### ETCHED FOIL

By embossing or etching treatment, the effective surface area of the metal foils can be effectively increased and thus an even greater capacitance obtained for a given bulk. Such capacitors are known as etched foil type to distinguish them from the normal plain foil electrolytics.

The layers of aluminium foil and impregnated paper are wound into a roll and this is then sealed in a metal or cardboard case or encapsulated in a resin or plastic moulding. During the sealing process precautions are taken to prevent evaporation of the moist paste or solution. These capacitors are not completely hermetically sealed, however, as a certain amount of gas is formed inside during normal operation.

The polarity of the lead-out wires or soldering tags is clearly marked on the body of the electrolytic capacitor, and must be carefully observed in use. Reversal of these polarities will cause a breakdown of the dielectric and the capacitor will be, in all probability, ruined.

To the left of the photograph appears the circuit symbol for an electrolytic capacitor. It will be seen that the positive and negative plates are clearly distinguished.

The maintenance of the dielectric film is dependent upon the application of a d.c. polarising potential, and a small leakage current is a normal characteristic of this type of capacitor. After a long period of non-use, the film disintegrates; subsequent application of a suitable polarising voltage will cause a heavy current to flow initially, but as the dielectric film is restored, this current will fall to its normal leakage value.

The rated working voltage marked on an electrolytic capacitor is somewhat lower than the voltage applied during manufacture in order to "form" the dielectric. Certain types, designed to withstand for a short period voltages in excess of the normal rating, have in addition a surge voltage rating which is approximately the same as the forming voltage. Surge-proof capacitors of this kind are used as "reservoir" capacitors in rectifier filter circuits.

### NOT FOR A.C. ALONE

The electrolytic capacitor is not suitable for circuits where only a.c. is present, but it is widely employed in circuits where an a.c. component is superimposed on a steady d.c. potential; for example, in filtering the pulsating output from power rectifiers and in decoupling cathode bias resistors in respect of low frequency signal voltages. As the frequency of the applied a.c. is increased, dielectric losses in the film increase and the power factor becomes very large (about 15 per cent). Consequently this restricts the use of electrolytics to low frequency applications, since at r.f. they present considerable impedance. This will be discussed more fully when we deal with a.c. theory.

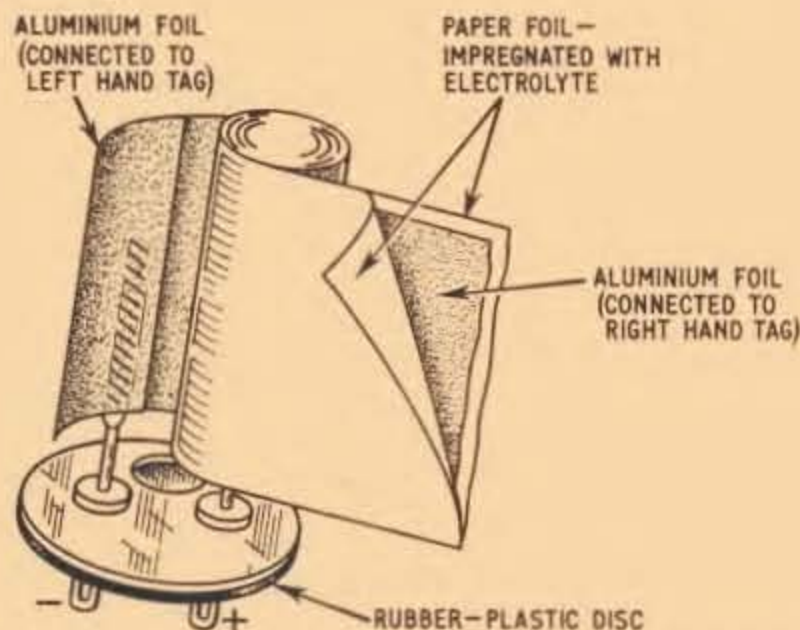

**Fig. 6.1.** The general form of construction of an electrolytic capacitor. The assembly is housed in either a metal or plastics case. Note that the dielectric—which consists of a thin insulating film deposited on one aluminium foil—is not actually shown in this diagram. This film is deposited by electro-chemical action during manufacture, and this particular process is referred to as "forming". It is essential to connect electrolytic capacitors according to the polarity indicated on the case. Sometimes the positive (+) tag or lead will be identified with a red mark and the negative (-) with black

The method of construction does not lend itself to fine control of capacitor values, and tolerances of -20 per cent and +50 per cent are quite usual, while tolerances of up to 100 per cent are not uncommon among certain types.

### WIDE RANGE OF VALUES

There is an extensive choice of capacitance values and working voltages in the electrolytic type capacitors currently available. The physical size of the component is naturally determined by the magnitude of these two factors.

Values ranging from about  $0.1\mu\text{F}$  to  $1,000\mu\text{F}$  for operation at 50 volts or lower are available in either a sub-miniature or normal size class. High working voltages, such as 150, 350, 450 and 600 are provided in the normal size class of components, where the upper capacity limit is generally about  $32\mu\text{F}$ ; although even here smaller components are becoming more usual due to the etched foil technique.

Standard values are multiples of  $8\mu\text{F}$  and combined units comprising two or three separate capacitor sections are made. In such double or treble units, a common negative connection is usually provided.

Some metal enclosed electrolytics have their outer casing connected internally to the negative electrode, while other types have their case isolated from the internal electrodes. Indication of the method adopted is printed on the side of the component, and should be noted before use.

Plastic sleeves are sometimes fitted to the smaller tubular types to allow the metal case to be insulated from chassis or from adjacent components. This is obviously not necessary in the case of plastic encapsulated types; these are very useful for close packing, for example on small printed wiring boards.

### NON-POLARISED ELECTROLYTICS

Non-polarised reversible versions of the foil type of electrolytic are also manufactured. Such capacitors consist of, in effect, two separate capacitors connected in series, back to back. The resultant capacitance is normally half that of the polarised type for a given working voltage.

Electrolytic capacitors (especially those of the aluminium foil type) are more liable to be influenced by external conditions than solid dielectric capacitors, and their efficient and reliable operation is dependent upon the strict observation of a number of points.

1. Ensure that the polarity is correct before connecting up.
2. Do not exceed the maximum rated working voltage. Likewise, do not operate under conditions where the applied d.c. will be considerably less than the nominal working voltage. Either extreme condition could bring about a deterioration of the dielectric film.
3. Never connect to a pure a.c. supply.
4. Keep away from sources of heat, such as power rectifiers and large output valves.

We have now dealt with the physical nature of capacitors, and have indicated how they react to direct current (d.c.). Further discussion of the capacitor will arise when we reach the subject of alternating current (a.c.).

# the 73 page

by Jack Hum  
G5UM

## Which Bands for What?

Having equipped himself with a receiver and an aerial in accordance with the suggestions offered on this page last time (February) the practical electronician\* will be in a position to take a serious interest in what goes on the short waves.

Before all else, however, he would be well advised to re-read the terms of his receiving licence. He may get a surprise or two at being reminded that he is prohibited from listening to anything outside amateur and broadcast transmissions.

Nobody can stop him from hearing what he shouldn't: he cannot pretend that the forbidden stations are not there as his tuning scale passes across them, for the process of hearing is an involuntary and virtually automatic one. Per contra, the process of listening is a conscious and deliberate one and needs to be exercised circumspectly and within the terms of the domestic licence.

To readers who know what "73" means the fascination of short-wave listening will lie in the six h.f. amateur communication bands rather than in the frequency areas allotted to broadcasting—though this is not in any way to decry the latter: they have been known to turn up some exotic growths to the enthusiasts prepared to dig between the rows of heavy kilowattage.

## Broad Guide to Propagation

Every explorer of the high frequency allocations soon discovers that each of the six bands possesses distinctive characteristics capable of being tabulated broadly as follows:

- 1.8Mc/s, local by day, up to 500 miles by night;
- 3.5Mc/s, 500 miles day, 1,000 miles night;
- 7 Mc/s, 1,000 miles day, 3,000 miles night;

\*And why not? Technicians, electricians, dieticians, and morticians! Electronicians are in good company!

14 Mc/s, 2,000 miles day, 8,000 miles night;

21Mc/s, world wide at certain times of year;

28Mc/s, 50 miles ground wave at sunspot 11-year minima, world wide at sunspot 11-year maxima.

Please note the operative word "broadly": the bands vary in their communication capability according to the time of year as well as by day and night. Moreover, an individual station's "breakthrough" capability must be taken into account as well: one well sited and well equipped (not necessarily with high power) will make himself heard in circumstances that vary markedly from the above "broad guide to propagation".

## Question of the QSL

Many—not all—transmitting amateurs exchange QSLs to verify that they have been in radio contact with one another. "The QSL is the final courtesy of a QSO", as some of them put it.

Millions of QSL cards shuttle about the world during the course of a year, some of them mailed direct where a verification card is needed from a rare country or station, but most of them passing through the QSL Bureaux which the national societies maintain.

The phrase "QSL" is one of many which the amateur transmitting movement adapted for its own use. (Originally it meant "Please send a receipt".)

It was a North West London amateur, G2UV, who invented the idea of the QSL card more than 40 years ago at a time when to work anybody at all over the air was an event, and some form of written confirmation that the event had happened was not at all a bad thing to have.

And so the QSL Card was born, a colourful adornment to many a "ham shack"—and a curse to those who do not collect them! For it must be admitted that the active amateur with a prominent signal on the band (any band!) will be deluged with useless reports from listeners whose sole desire is to secure his card rather than to offer a worthwhile comment on his signal.

It is to the weaker stations, those hard to winkle out, those likely to be surprised that their signals reached your aerial at all, that listener reports may be most profitably sent.

Our illustration shows a QSL card designed to cover all modes of

operation while presenting the operator with the minimum amount of writing to do.

The main callsign is G8LM. Subsidiary callsigns are added for "Stroke P" (portable) operation, "Stroke A" at an alternative address, and "Stroke M" for mobile.

Being a club station G8LM will have an official list of GPO-approved operators, one of whom signs the card and adds his own callsign, at the same time wishing the recipient the universally-known "73" or "Best Wishes".

Suitably modified, a listener report card could follow the style of this one—except that the callsign in large letters would be replaced by the person's BRS (British Receiving Station) or BSWL number, these being allocated by the Radio Society of Great Britain and the British Short Wave League respectively.

Coloured QSL cards are not inexpensive. So get plenty printed while your printer has the job in type—and send them out sparingly only to operators whom you are pretty sure from the sound of their

*Official Station of the Radio Section of Murphy Radio Sports Club*

<b>G8LM</b>	Welwyn Garden City, ✓ Herts., England.
<b>G8LM/P</b>	located at <input checked="" type="checkbox"/>
<b>G8LM/M</b>	located at <input checked="" type="checkbox"/>
<b>G8LM/A</b>	located at <input checked="" type="checkbox"/>
Radio <b>G3AAZ</b>	worked here <b>1.3.65</b> QRG <b>145.1 Mc/s</b>
Your sigs <b>RST 59</b>	on <b>CONVERTER INTO 8C342RX</b>
TX <b>A-STAGE WITH 4M403/20 p.a. INPUT 15 WATTS.</b>	
Antenna... <b>5-ELEMENT YAGI</b>	
PSE QSL <b>-AND 73 TO YOU G8LM</b>	<i>Jack</i> operator <b>G5UM</b>

signals will be glad to get them.

What to do when the other men's cards start coming back to you? Use them as wallpaper? Thousands of amateurs do—but how dustladen, faded and generally secondhand they look after a few years on display!

A sensible scheme is to pin up one from each country heard or worked, and to file the rest.

# the 73 page



# pe

## MODULE FOUR

# AUDIO AMPLIFIER AND R.F. PROBE

FOR OUR next project we have chosen a two-stage audio amplifier, a device which has a multiplicity of applications, as we shall see. The circuit of the amplifier is given in Fig. 1. Both transistors are arranged in the common emitter mode. That is, the emitter is common to both the input and output signals.

The input signal is applied to the base of TR1, and it appears in an amplified form at the collector. From here the signal is coupled through C2 to the base of TR2. The signal current in the collector circuit of this transistor is fed through an earpiece or pair of headphones.

Some sort of input level control is necessary to avoid overloading the transistors with powerful input signals. This is arranged by using the potentiometer VR1, which takes the form of a vertically mounted "printed board" type skeleton preset.

### CIRCUIT ACTION

To avoid disturbing TR1 biasing conditions, the signal is taken from the potentiometer to the base through the coupling capacitor C1. Base current for TR1 is set by R1, and a small degree of d.c. stabilisation is provided by the action of the collector load R2. This is because R1 is returned to the collector instead of direct to the negative supply line. If there is a tendency for the collector current to rise due to thermal effects, the voltage across the load R2 would also rise.

This would cause a drop in the voltage at the collector and a corresponding fall in current through the base resistor R1. Thus, the fall in base current would tend to pull back the rise in collector current.

In the circuit under discussion, however, there is no possibility of the transistor being damaged due to a rise in collector current, since the current is safely limited by the relatively high value collector load. The maximum current that could possibly flow is only about 1mA on a 4.5 volt supply. Nevertheless, this simple form of stabilisation is worth noting.

An increase in leakage current, due for instance to the transistor being subjected to high temperature in a circuit where the collector current is limited, results in a progressive drop in gain until eventually the transistor saturates or "bottoms" and the gain drops to zero.

The base current in TR2 is set by R3. For best results the value of R3 should be adjusted for a collector current of about 3mA. The value chosen was found to satisfy this condition in the prototype.

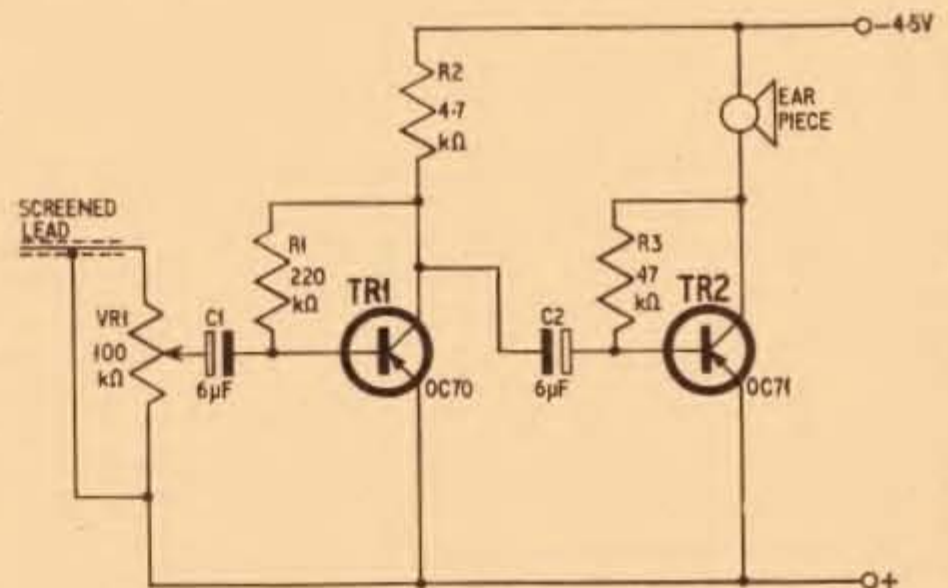

Fig. 1. Circuit diagram of the amplifier

## SIGNAL TRACING

The amplifier is not difficult to construct and it operates well from a 4.5 volt battery. The earpiece should be medium or high impedance. For signal tracing, the input of the amplifier is connected across the various signal circuits of the equipment under test. For example, if the exercise is to locate a defect in a record player amplifier, the input would first be applied across the pick-up circuit with the gain turned up. The pick-up signal should be heard at good quality if this item of the player is working correctly.

The test amplifier input would then be connected to the grid of the first stage, to the grid of the second stage and so on forward towards the loudspeaker. If the signal can be heard at the grid of, say, the first stage, but not at the grid of the second stage, then the fault would lie somewhere in the first stage or in the coupling between the first stage to the second stage. Further component to component tests of this nature would soon reveal the actual location of the fault.

Distortion could be checked in a similar manner, of course, for the test amplifier would show exactly at what point in the circuit the distortion takes place. Normal servicing techniques would then be used to locate the faulty component.

The amplifier is sufficiently sensitive to check the output of pick ups, tape heads and microphones direct. However, as it stands it is suitable only for audio signal tracing.

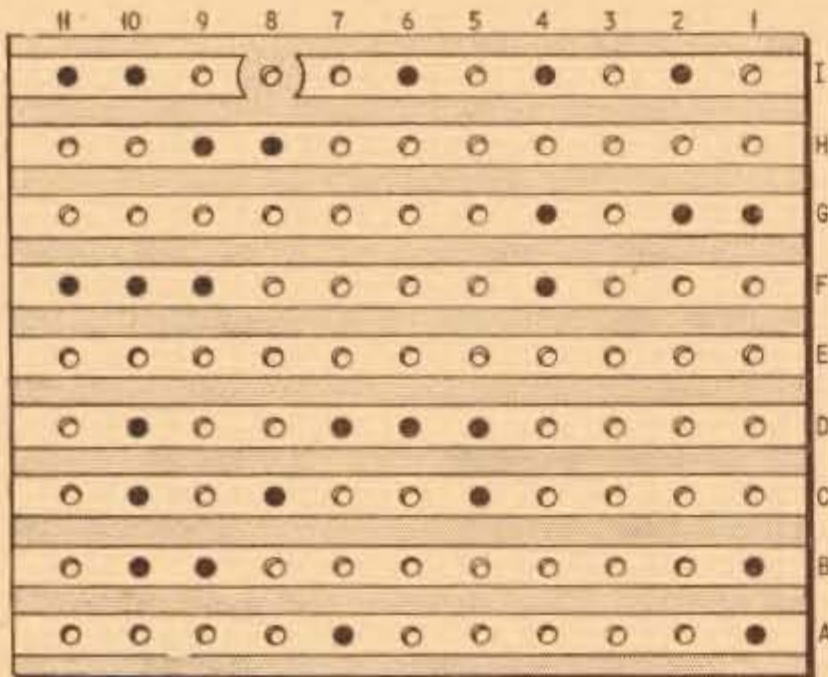

Fig. 2. Underside view showing connections

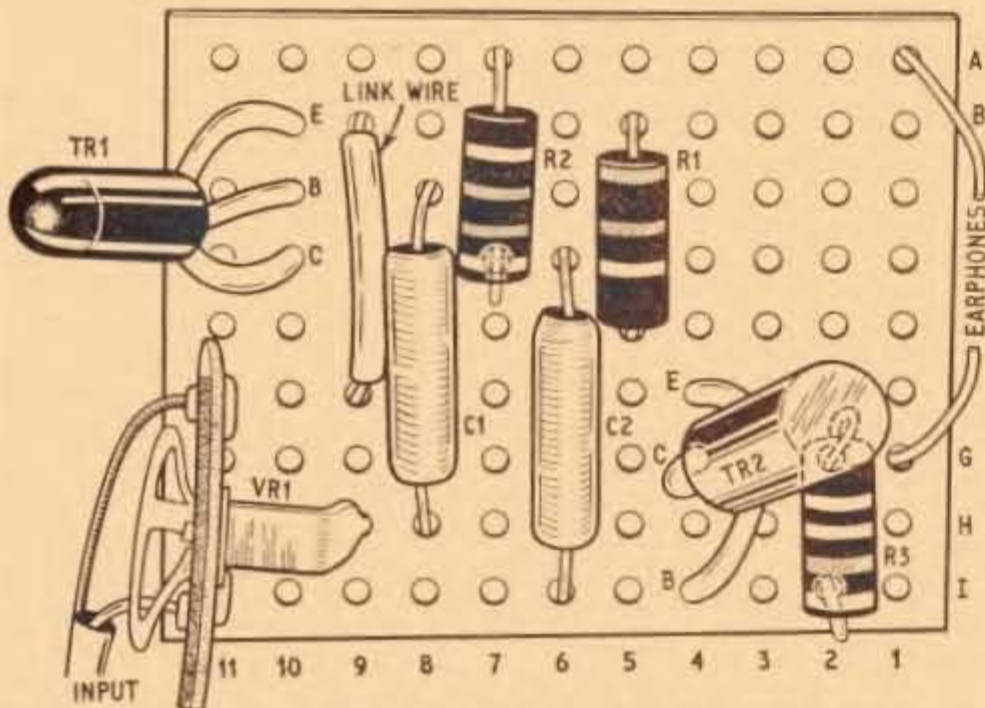

Fig. 3. Component layout and external leads

## COMPONENTS . . .

### AUDIO AMPLIFIER

#### Resistors

R1 220k $\Omega$   
R2 4.7k $\Omega$   
R3 47k $\Omega$  } All  $\frac{1}{4}$  watt 10% carbon

#### Potentiometer

VR1 100k $\Omega$  skeleton type preset (Radiospares)

#### Capacitors

C1 6 $\mu$ F 6V (T.C.C. type CE2)  
C2 6 $\mu$ F 6V (T.C.C. type CE2)

#### Transistors

TR1 OC70 or OC71 (Mullard)  
TR2 OC71 (Mullard)

#### Miscellaneous

Sample Veroboard, p.v.c. insulated wire, 4.5 volt battery, earpiece medium impedance

### R. F. PROBE

#### Capacitor

C3 1,000pF 250V tubular ceramic

#### Diode

D1 OA81 (Mullard)

#### Miscellaneous

Ball-point pen (see text), screened wire, p.v.c. insulated wire, crocodile clip

## CONSTRUCTION

Fig. 2 shows the Veroboard layout to suit the circuit in Fig. 1. This shows the copper strip side of the board.

Fig. 3 shows the components and link wire in position on the top of the board. In spite of the relatively large number of components used in this project, there should be no difficulty in accommodating them all on the small piece of Veroboard.

The potentiometer is mounted by its two outside tags, as in the sixth project. The centre tag (that connected to the slider) needs to be bent carefully underneath the component and extended to the appropriate hole by a length of p.v.c. insulated copper wire.

The resistors can be  $\frac{1}{4}$ - or  $\frac{1}{2}$ -watt insulated carbon type, as before, while the electrolytic capacitors are sub-miniature versions. Wire ended resistors and small capacitors can be easily arranged to span the required distances by bending the wires to meet the holes used. This permits a degree of flexibility in the choice of component.

### R.F. PROBE

For the tracing of modulated r.f. signals, a detector or demodulator must be used in front of the amplifier. This is not a complicated device, and consists only of a couple of components, as shown in Fig. 4. Here the test r.f. signal is applied across a shunt rectifier via the capacitor C3, and when the circuit is connected to the

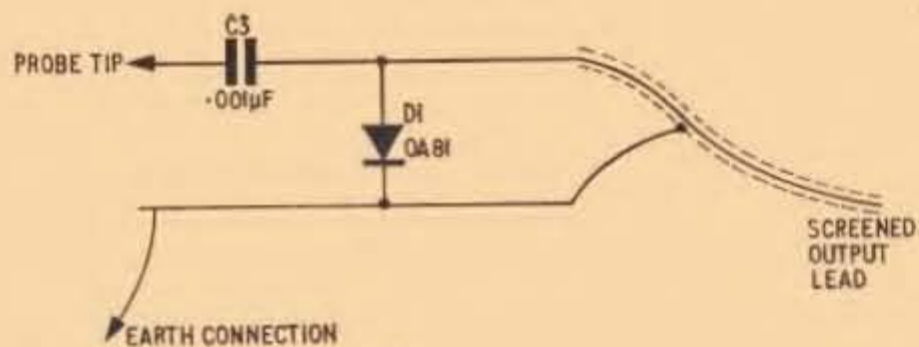

Fig. 4. Circuit of r.f. probe

amplifier the input potentiometer (VR1) serves as the detector load, across which the audio signal is developed.

The ideal arrangement is for the detector circuit to be housed in an insulated plastics case which can form the basis of a test probe. Such a housing is shown in Fig. 5. This is the plastics case of an inexpensive ball-point pen which can be obtained from a number of stationers. The type of pen in question has a metal ferrule between its two screw-in sections.

The plastics ink cartridge and ball-point assembly is removed. Most of the plastics ink cartridge is cut off and discarded, while the remaining metal ball-point tip and a short piece of the tube are thoroughly cleaned. The ball-point end, in fact, forms the connector of the probe, as shown.

The capacitor and diode are connected in series and the free wire end of the capacitor is soldered to the metal ball-point assembly. Care has to be taken over this exercise to avoid damaging the remaining short length of plastics tube.

Next, the free wire end of the diode and the junction of the capacitor and diode are connected to two thin insulated lengths of connecting wire. The retractor button at the pocket end of the pen housing is removed and a three-foot length of thin, screened lead is threaded through the hole at the end of the barrel. The braid is stripped back and soldered to the wire connected to the free wire end of the diode. A second, very thin wire is also soldered to this screen.

The inner conductor of the screened lead is then soldered to the wire which is connected to the junction of the capacitor and diode. The capacitor, diode and ball-point assembly are then slid into the housing and the thin wire connected to the braid is then arranged to

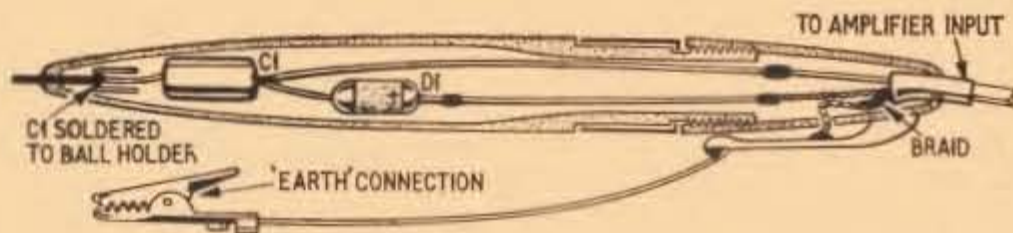

Fig. 5. Cut away section of the probe. Note the connection of the braid to the clip and the diode; centre core to C1 and D1

pass through a small hole in the pen top and soldered to the clip. This provides the "earth" connection.

The probe is completed by soldering an earth wire terminated by a crocodile-clip to the outside of the metal clip. The far end of the screened lead is, of course, connected to the input of the amplifier, in such a way that the braid connects to the battery positive line.

### TRACING MODULATED R.F.

The amplifier and probe combination is now very useful indeed, for it allows the tracing of r.f. signals in radio receivers. All that is necessary is to connect the "earth" lead to the "earth" or chassis of the equipment under test and then to pick up the r.f. signal with the tip of the probe at any convenient point in the circuit.

A reasonably powerful station can, in fact, be picked up at the control grid of the frequency changer valve in a radio set, for instance, and the signal can be followed through the equipment, at i.f., right up to the input of the detector stage. Thus, any discontinuity in the circuit will be immediately revealed.

Care should be taken when using any test equipment with a.c./d.c. type receivers where the receiver metal chassis or earth circuit may be connected to the "live" side of the mains supply. When testing equipment of this nature, it should always be seen that the neutral side of the mains is on the "earth" or chassis circuit. The test equipment should also be isolated by capacitors—one in each lead—not exceeding  $0.005\mu\text{F}$ . Preferably, the equipment under test should be isolated from the mains by a transformer.

*For reasons of safety it is NOT recommended that this r.f. probe should be used on a.c./d.c. type equipment.*

## PRACTICAL ELECTRONICS BINDERS

EASI-BINDERS specially designed to hold 12 issues of PRACTICAL ELECTRONICS are now available.

These binders are finished in maroon waterproof and greaseproof cloth and are embossed with gold lettering on the spine.

Order your binder from:

Binding Department,  
George Newnes Ltd.,  
Tower House,  
Southampton Street,  
London, W.C.2.

The price, per binder, is 13s. 6d., inclusive of postage.

## PRACTICAL WIRELESS

THIS MONTH

### F. M. TUNER

High quality design using a pulse counter discriminator

### THE IONOPHONE

Describing a new loudspeaker technique

### SINGLE SIDEBAND

Using a product detector

### PLUS FREE 24-page Pocket Guide

Packed with information including comprehensive wavelength/frequency conversion tables, decibel calculations, wire gauges, transformer matching.

April issue on sale NOW. Price 2s.

TEST YOUR

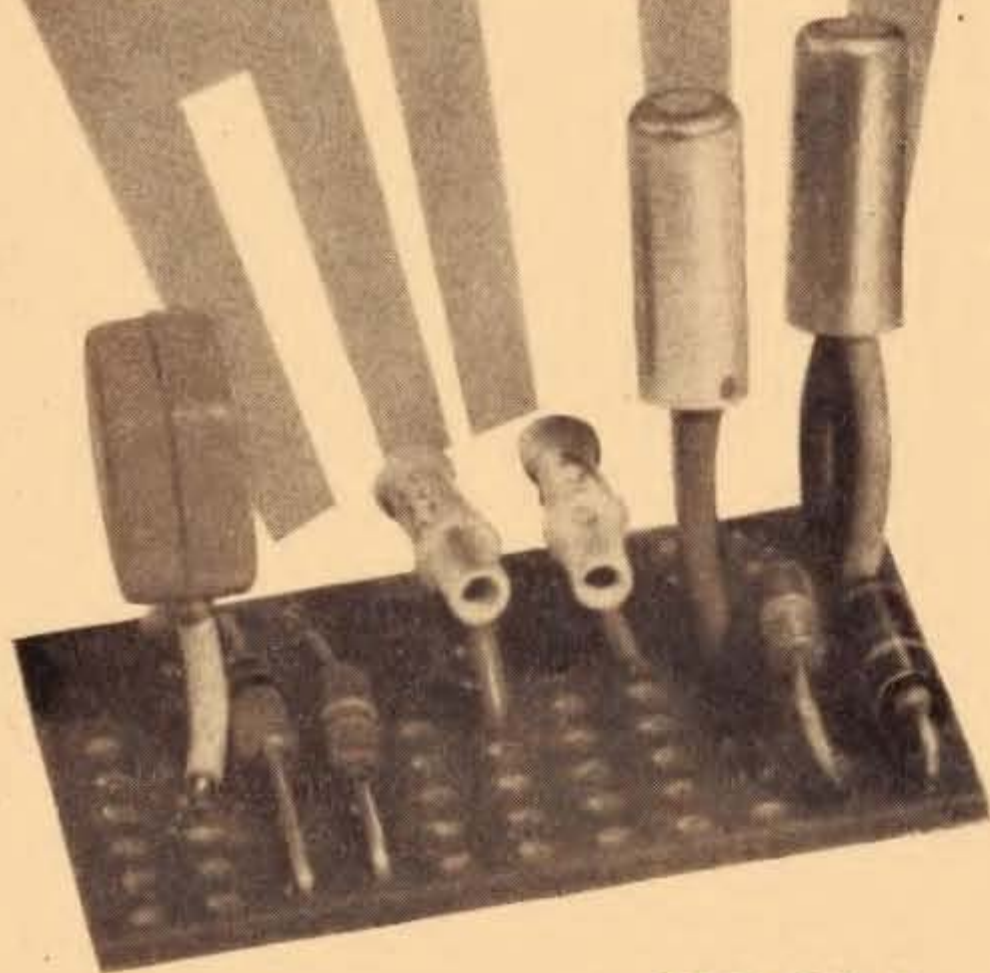

## with this Multivibrator

pe  
MODULE FIVE

ANOTHER interesting exercise in transistors is in the building of a multivibrator unit. A very useful device of this kind can be easily built upon the sample Veroboard, as this article reveals.

The complete circuit is given in Fig. 1. From this it will be seen that two readily obtainable and inexpensive Mullard transistors are employed. The collector of TR1 is capacitively coupled to the base of TR2, while the collector of TR2 is back-coupled capacitively to the base of TR1. This represents the basic circuit of any multivibrator, except that where valves are employed the control grid and anode are wired to take the place of the base and collector of transistors.

It is interesting to note that the first valve multivibrator was evolved as early as 1918.

### CIRCUIT ACTION

The cross-coupling of the multivibrator circuit produces what, in effect, is an oscillator, due to positive feedback. Oscillation is sustained due to the loop gain of the circuit being greater than unity.

Actually, the circuit functions by one transistor being switched on while the other is switched off. The switching on and off alternates between the two transistors at a rate determined by the time-constant of the circuit.

When power is applied to the circuit from the battery, a slight unbalance in the components and random current disturbances in the circuit push one transistor towards current cut-off and the other towards full conduction. This particular state is regenerative due to the cross-coupling. One transistor is switched fully on while the other is switched off, alternating very rapidly with the reverse condition.

Let us suppose that TR1 is "on" and TR2 is "off". This makes the collector end of C2 less negative than the base end. C2 thus charges and, at the same time, the base of TR2 goes negative bringing it into conduction from its "off" state. Again, the effect is regenerative, so that TR2 is switched fully on and TR1 is switched off.

This time C1 charges, making the base of TR1 go negative, thereby causing the cycle to repeat, but this time in relation to the other transistor. The circuit is in that way caused to oscillate in terms of switching from one transistor to the other.

The speed of the switching or the repetition frequency of the multivibrator is governed by C1 discharging through R2, and C2 discharging through R3, and thus by the time-constants of these circuits. In effect, there is also a discharge path through the bases of the transistors, so that to some extent the repetition frequency is governed also by base leakage currents—and hence, by temperature.

It is interesting to note that when  $C1 \times R2$  equals  $C2 \times R3$  the resulting square wave has equal on and off (mark and space) times, as shown by the accompanying waveform in Fig. 1. The mark/space ratio can be adjusted by unbalancing C1,R2 and C2,R3, but the circuit will fail to work correctly where such unbalances are very large.

### RICH IN HARMONICS

Thus, the multivibrator produces a square wave output. This means that its output is very rich in harmonics of the fundamental frequency, for a pure square wave can be analysed as a fundamental sine





# AUDIO OSCILLATOR

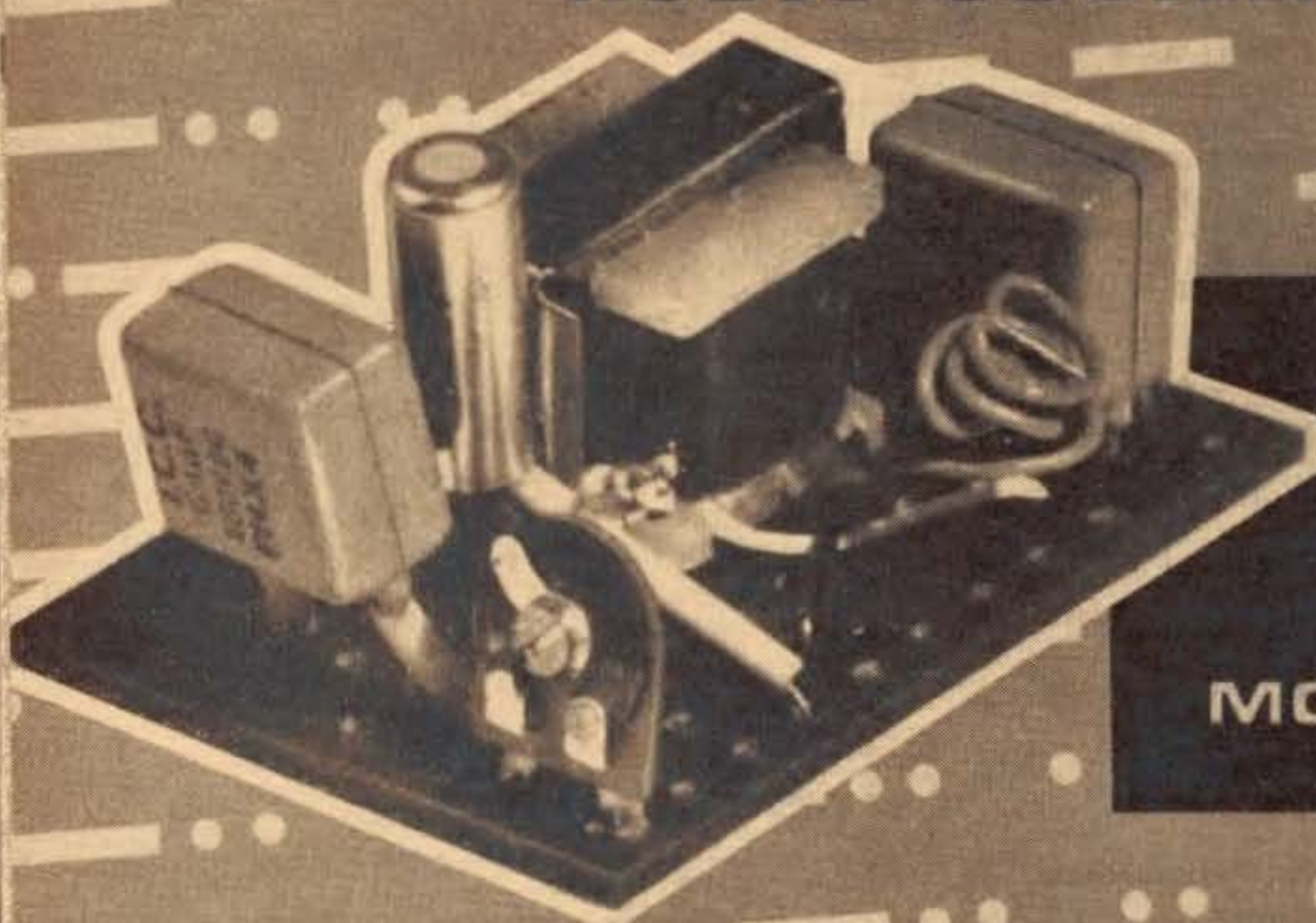

pe  
MODULE SIX

THE NEXT article in this series describes how Veroboard can be used to construct an audio oscillator. As will be seen from Fig. 1, the circuit is very straightforward. It employs a single transistor to create a positive feedback loop by means of transformer T1. Feedback takes place from the collector to the base, and the signal is developed across the resistor in the emitter circuit. This circuit is known as a Hartley oscillator.

To provide some control over the amplitude of the output voltage, the emitter resistor constitutes the resistive element of a preset potentiometer VR1, the output signal being taken at the required level from the slider, via the coupling and isolating capacitor C2.

The base current is determined by the value of R1, and with an OC71 transistor a value of 220 kilohms was found to be satisfactory. Capacitor C1 acts as a decoupling component in essence, and without it the circuit will not oscillate. A battery supply in the order of 4.5 volts is adequate for normal operation.

## CONSTRUCTION

Fig. 2 shows the copper strip side of the Veroboard, and reveals clearly how some of the strips need to be broken to form the pattern of the circuit. The filled-in holes indicate component connections with p.v.c. insulated wire.

Fig. 3 shows the components actually in position on the reverse side of the board, with the external connecting links which are required.

## COMPONENTS

Owing to the small dimensions of the board used, it is obvious that miniature components must be used. This applies particularly to items like capacitors, potentiometers and transformers. Ordinary  $\frac{1}{4}$  or  $\frac{1}{2}$  watt insulated carbon resistors are suitable. These have a body length of about 0.4in and a diameter of about 0.15in.

The capacitors should be of the sub-miniature type designed for low voltage transistor applications, while the potentiometer (VR1) should be an open

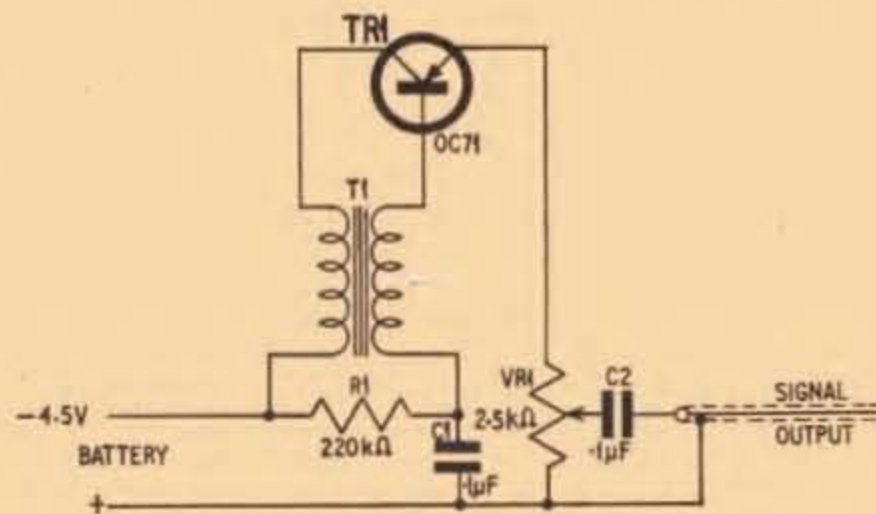

Fig. 1. Circuit diagram of the oscillator

(skeleton) preset type designed for vertical mounting on a printed board. The type used in the prototype has dimensions of  $\frac{3}{4}$ in in height and  $\frac{1}{2}$ in in width. The centre tag of this type does not quite line up with a hole on the board, but by bending it carefully underneath the body of the component, a small piece of copper wire can be used to extend the connection to the appropriate hole on the board. The two outside tags (i.e. those connected across the resistive element) should be arranged to pass through the appropriate holes A1 and C1.

## TRANSFORMER

The other problem component is the transformer. This should have a ratio of between 2:1 and 6:1. A driver transformer designed for transistors is quite suitable; the centre-tap on the secondary winding is not used. Miniature types designed for transistor circuits and printed board mounting are obtainable from component specialists.

The type employed in the prototype has thin wire terminations which can be pushed into the appropriate holes in the board and will be quite firmly anchored when soldered to the copper strips. Some transformers have lugs at the base of the metal clamp which can be pushed through slots in the board and

## COMPONENTS . . .

### Resistor

R1 220k $\Omega$

### Potentiometer

VR1 2.5k $\Omega$  skeleton type

### Capacitors

C1 0.1 $\mu$ F 250V (T.C.C. type PMX4)

C2 0.1 $\mu$ F 250V (T.C.C. type PMX4)

### Transformer

T1 Transistor driver transformer 2.8:1 (Radio-spares type T/T6)

### Transistor

TR1 OC71 (Mullard)

### Miscellaneous

Sample Veroboard, p.v.c. insulated connecting wire, screened output cable, 4.5 volt battery

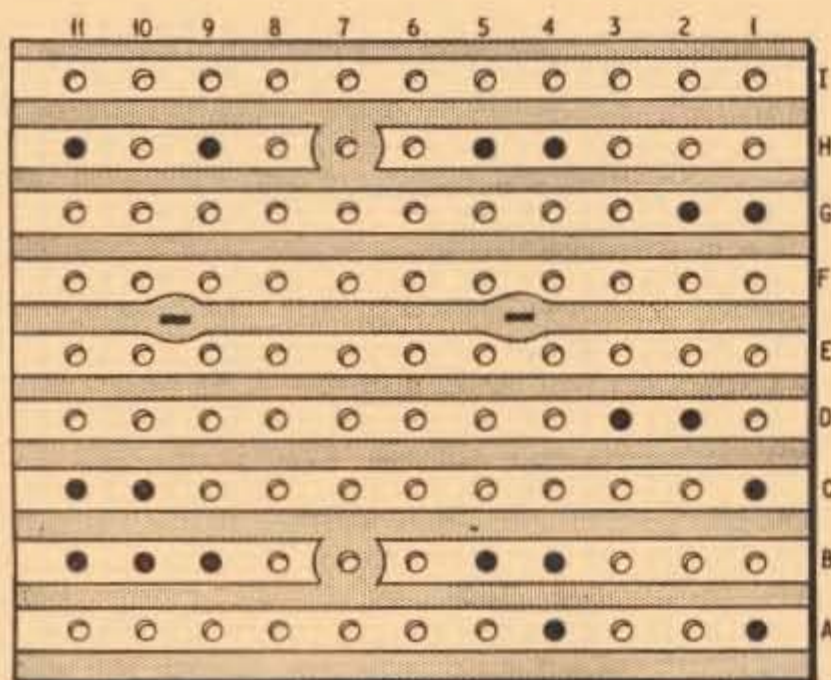

Fig. 2. Underside view of the board showing the copper strip breaks and position of the transformer mounting lugs

twisted with a pair of pliers. If these lugs are not needed they can be bent back underneath the body of the transformer.

The circuit will only oscillate when the phasing of the windings gives positive feedback. In practice it may be necessary to experiment by reversing one of the windings in the circuit to achieve oscillation. It may be found possible to reverse the phase by changing over the wires which form the transformer terminations. If this is not possible, then the pattern of the circuit on the board will need to be altered slightly to achieve the correct phase.

Soldering should be performed with a small instrument iron (15 or 25 watts). Prolonged heat on the small components, particularly on the transistor wires, should be avoided by using a thermal shunt (pair of pliers) whenever possible. The transistor wires should not be cut down.

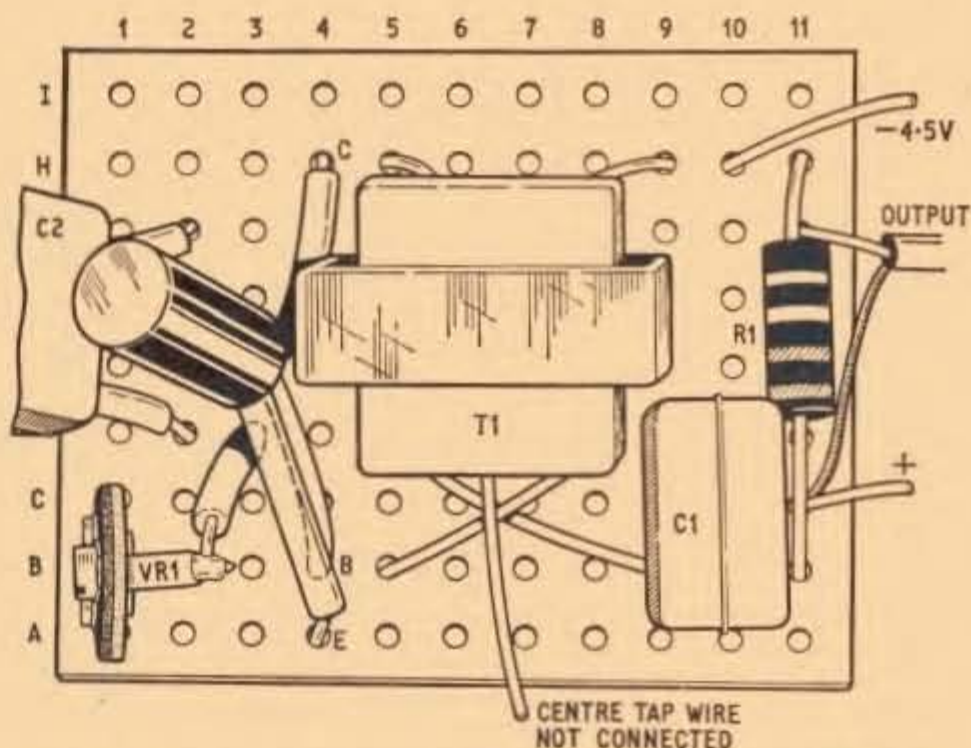

Fig. 3. Component layout of the unit. Note the wiring of the transformer. If the correct phase is not achieved, the connections on one winding only should be reversed if oscillation is not apparent

## APPLICATIONS

The device provides adequate output for working a pair of headphones. As a morse practice oscillator, a morse key can be arranged to switch the power supply.

The assembly can also be used as an audio test oscillator, the output in this case being applied to the input of the audio amplifier under test. By injecting the oscillator signal to the control grid circuits of each stage, up to the loudspeaker or output terminals of the amplifier, the defective stage can be located.

The signal can also be employed to modulate an r.f. signal of either a small transmitter or a signal generator. Indeed, for any application where an audio signal is required the oscillator can be brought into service.



# NEWS BRIEFS

## Cybernetic Drawing

**S**OVIET engineers have devised a cybernetic method of drawing any black and white picture with the help of an electronic computer and phototelegraph.

Man's only job is to give the computer an assignment. From numerous elements of images stored in the computer's memory as sets of zeroes and unities denoting black or white dots, the machine pieces together the picture required.

Engineers have designed an electronic machine which creates the images and transmits them on to a phototelegraphic receiver.

Although the machine performs up to 10,000 operations per second, which is a comparatively slow performance, it will take not more than 30 minutes to synthesise an image, depending on the complexity of the picture. Usually it takes one to seven days for a man to do this job by hand. No controller is required because the machine does the checking itself.

The cybernetic method of synthesising images is also applicable to other tasks: from designing of standard types of buildings to the production of animated cartoons.

## Sound in the Royal Festival Hall

**A** GREAT deal has been said both publicly and privately about the "assisted resonance" in the Royal Festival Hall, and whether or not it is a realistic attempt to enliven the acoustics. Mr T. E. Bean (General Manager) insists, and quite rightly so, that there is nothing magic about it—no back room boys turning up the bass control of a public address amplifier. The secret is in the ceiling as John Valence explained last month. The effect can, however, be quite different between a large orchestra and a small ensemble. Much depends also on the types of instruments used.

Another feature of the modifications in the Hall is a closed circuit television system. Patrons who normally arrive after the concert has begun, usually wait until the end of the first piece before entering the auditorium. Now they can, to some extent, join in by watching the concert on four 23in television receivers installed by E.M.I. Electronics. The cameras are fixed in the spotlight housing below the circle balustrade.

## Retired Computer

**L**EO I, claimed to be the world's oldest operating electronic computer, retired from active service on 4 January. For nearly fourteen years the computer has handled the finances of J. Lyons & Company.

Parts of this historic computer, which contains over 7,000 valves and half a ton of mercury, will be given to the Science Museum in London. It was originally designed and installed by English Electric in 1951.

## Counting the Telephone Calls

**C**AMERAS are to replace paper and pencil for recording millions of telephone exchange meter readings which register each subscriber's telephone calls. After extensive tests at Edinburgh—where it cut the reading time for 1,000 meters from 4 hours to 10 minutes—the new photographic system is to be introduced nationally.

Earlier Post Office experiments with photographic meter reading over a number of years had been abandoned due to technical difficulties and prohibitive costs.

The specially designed equipment which the Post Office is now using consists of a pre-focused camera mounted at the back of a "hood" resembling a pyramid shaped loudhailer. All the meter reader has to do is to press the mouth of the hood on to a selected square of upright rack which houses the meters—and pull a trigger. This sets off a flash inside the hood, giving a shadow-free picture of 100 meters on under a square inch of film. 3,500 meters can be "read" before the camera needs reloading.

Films taken from the cameras are wound on to automatic projectors which show up individual meter readings in numerals half an inch high. Each reading is recorded twice on a punched card by different operators. Both readings are checked against each other automatically before the final figure is passed to the telephone billing department.

## Weather "Wheel" Rolls Around Earth

**A**N accurate daily weather report from orbiting space "eyes" is getting nearer. The first such official programme is expected to commence next year and its impact on world weather reporting will revolutionise conventional meteorological systems. The RCA-built TIROS launched on 20 January from Cape Kennedy is the forerunner of the new space age weather reporter.

Travelling at 460 miles high, the latest TIROS satellite is designed to photograph the entire Earth every day. Equipped with two television cameras it will "roll" about its orbit like a cartwheel, sending back valuable information.

## UK3 In Space

**T**HE THIRD British satellite UK3, due to be launched in the U.S.A. during the winter of 1966-67, is to be built entirely in the United Kingdom, experiments on the ionosphere will be carried out while the satellite is in orbit at an altitude of 55 kilometres.

Communication with the satellite will be by the standard Goddard Space Flight Center pulse frequency modulation telemetry system on a frequency band of 136Mc/s for the transmitter and 148Mc/s for the receiver. Information received by the satellite will be stored until it comes within range of the ground communications centres. The manufacture of the satellite structure is the responsibility of the British Aircraft Corporation, while the main contractor for the electronics is G.E.C. (Electronics) Limited. ★

**FREE** *INSIDE  
NEXT  
MONTH'S* Practical Electronics

# 2 DOUBLE SIDED BLUEPRINTS

*TO BUILD*

1. SIMPLE SHORT WAVE RECEIVER
2. AUDIO OSCILLATOR AND OUTPUT METER
3. MICROPHONE MIXER UNIT

*Other outstanding features include :*

**AN ELECTRONIC SPORTS EVENTS TIMER**



**ORDER  
YOUR COPY  
NOW!**

FILL IN AND HAND TO YOUR NEWSAGENT

Please send/  
reserve\*  
PRACTICAL  
ELECTRONICS  
(2/6) each month,  
commencing with  
the May issue,  
on sale April 15

TO.....

NAME OF NEWSAGENT

NAME.....

ADDRESS.....

**MAY ISSUE**

**ON SALE**

**APRIL 15**

# Just out!

## PRACTICAL HOUSEHOLDER ANNUAL - 1965

PACKED WITH NEW IDEAS AND EXPERT KNOW-HOW  
ON IMPROVING YOUR HOME

Handymen! Here's your guide to a better, brighter, more comfortable home — bringing you dozens of do-it-yourself jobs you can plan and carry out now.



### SPECIAL SECTIONS ON:

**WOODWORKING TOOLS.** The right tools for each job — how to adjust, sharpen and care for them.

**SIMPLE WOODWORKING PROJECTS.** Covers a variety of how-to-make projects, including Shelves and Cupboards, Divan Headboards, Bunk Beds and a Child's Playhouse.

**HOME IMPROVEMENTS.** Unusual Wall Treatments — Room Dividers — Making a Service Trolley — Tiling a Wall.

**UNDERSTANDING ELECTRICS.** All the know-how you need on domestic electricity and power points.

**OUTDOOR IMPROVEMENTS.** How to Level Lawns — Build Garden Furniture — Screen Walls in Novel Patterns — Nesting Boxes — A Spanish-Style Patio.

**PROJECTS AROUND THE HOME.** How to Fit French Windows and Decorate Outside Walls with Cement Finishes.

**BIG DEMAND!** *from all Newsagents & Bookstalls* **2/6**  
**GET YOURS NOW!**

# NEW!

## AN AUTHORITATIVE HANDYMAN'S ENCYCLOPÆDIA Complete in 26 Weekly Parts

### PART 1 OUT MARCH 22

Written throughout by leading authorities, with a wealth of how-to-do-it illustrations, this authoritative Weekly Part Work brings you *instant A-Z reference* on the whole range of home improvement, repair and maintenance

### PRIVILEGE PRICE BINDING OFFER

available to transform your Encyclopædia into 3 handsome volumes for permanent reference.

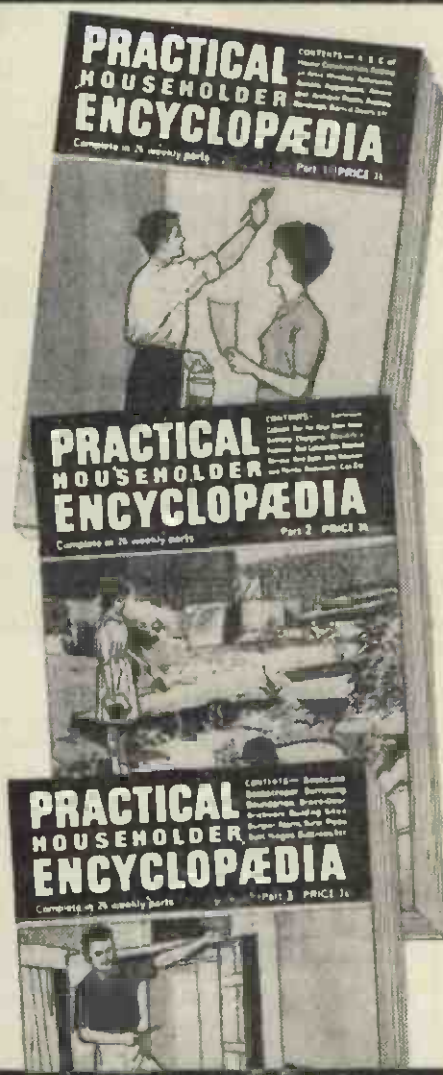

### THE WHOLE WORK COMPRISES:

Over 700,000 Words • Over 1,600 pages, more than 2,500 Entries • Thousands of How-to-do-it Photographs, Diagrams, Drawings • 64 Pages of Full Colour Plates • Full Coverage Major Handyman's Subjects • Guide to Tools and Materials • Legal Advice

# PRACTICAL HOUSEHOLDER ENCYCLOPÆDIA

**3/6  
WEEKLY**

PLACE A REGULAR ORDER WITH YOUR NEWSAGENT!

# RETURN - OF - POST ON CASH OR C.O.D. ORDERS

## ● MARTIN FM TUNER KIT

Fully transistorised, unit construction, front end and I.F. amplifier supplied already built and tested. Illustrated leaflet available. £12.17.6. Deposit £2.11.6 and 12 monthly payments of 18/11. Total credit price £13.18.6

## ● SPECIAL OFFER!! STEREO CARTRIDGES

RONNETTE 105 Stereo/Mono Cartridge. Complete with fixing bracket and styli. List 59/4. OUR PRICE 23/6. Post Free.

## ● ILLUSTRATED LISTS

Illustrated lists are available on LOUDSPEAKERS, TAPE DECKS, TEST GEAR, GRAMOPHONE EQUIPMENT, AMPLIFIERS. Any will be sent free upon request.

## ● AMPLIFIER KITS

We have full stocks of all components for the Mullard 510, Mullard 3-3, Mullard 2 and 3 Valve Pre-amp. Mullard Stereo, Mullard Mixer. Fully detailed list on any of these sent upon request. Instruction Manual: All Mullard Audio Circuits in "Circuits for Audio Amplifiers", 9/5. Post free.

## ● LATEST TEST METERS

	Cash Price	Deposit	Mthly/Pmts.	Credit Price
AVO Model 8 Mark III ..	£24. 0.0	£4.16.0	12 of £1.15.2	£25.18.0
AVO Model 7 Mark II ..	£22. 5.0	£4. 8.0	12 of £1.12.9	£24. 1.0
AVO Multiminor Mark 4 ..	£9.10.0	£1.18.0	12 of 14/4	£10.10.0
T.M.K. TP10 ..	£4. 7.6	£1. 7.6	3 of £1.3.4	£4.17.6
T.M.K. TP55 ..	£6.11.6	£1.11.6	6 of 19/2	£7. 6.6
T.M.K. Model 500 ..	£9.17.6	£1.17.6	12 of 15/-	£10.17.6
TAYLOR MODEL 127A ..	£10.10.0	£2. 2.0	12 of 15/8	£11.10.0

Full details of any of the above supplied free on request.

## ● TAPE RECORDING EQUIPMENT

	Deposit	Mthly/Pmts.	H.P. Price
<b>TAPE DECKS</b>			
ALL CARRIAGE FREE			
COLLARO STUDIO, latest model,	£2. 3.6	12 of 16/4	£11.19.6
Two track, Bradmatic Heads			
<b>MARTIN TAPE AMPLIFIER KITS</b>			

**Tape Amplifiers**  
For Collaro 8311-V 2-Track £11.11.0. 8311-4-V 4-Track £12.12.0.  
**Tape Pre-amplifiers**  
For Collaro 8319-CP 2-Track £8.8.0. 8319-4-CP 4-Track £9.9.0.  
Drop through assembly for mounting 8319 Pre-Amp under Collaro Deck, £1.11.6.  
Carrying Cases with speaker. For Collaro Deck and 8311 Amplifier, £5.5.0.  
CREDIT TERMS available on decks, amp. and cases. Ask for quote.

**MULLARD TAPE PRE-AMPLIFIER KIT**  
We stock complete kits and all separate components for the Mullard Tape Pre-Amplifier. Fully detailed list available.

## ● GRAMOPHONE EQUIPMENT

	Cash Price	Deposit	Mthly/Pmts.	Credit Price
<b>ALL LATEST MODELS</b>				
<b>ALL POST FREE</b>				
<b>RECORD CHANGERS</b>				
GARRARD AUTOSLIM (Mono PU fixed head)	£6.10.0	£1. 5.0	6 of £1.0.0	£7.5.0
GARRARD AUTOSLIM De-Luxe AT6 (Mono PU) ..	£11. 9.0	£2. 6.0	12 of 16/11	£12.9.0
GARRARD AUTOSLIM AT6 (Stereo/Mono PU) ..	£12. 5.4	£2. 9.4	12 of 18/-	£13.5.4
GARRARD LAB AUTO A (GC8 Mono PU) ..	£16.12.6	£3. 6.6	12 of £1.4.5	£17.19.6
GARRARD AT5 LM (3000 LM) Low mass pick-up arm (9TA Stereo/Mono PU) ..	£12.15.0	£2.15.0	12 of 18/4	£13.15.0
GARRARD AT5 (Mono PU plug in head) ..	£10. 8.2	£2. 4.2	12 of 15/4	£11.8.2
B.S.R. UA15 (TC8 Mono PU) ..	£7.15.0	£1.18.0	6 of £1.2.0	£8.10.0
B.S.R. UA15 (TC8S Stereo/LP/78) ..	£8.15.0	£2. 6.0	6 of £1.4.0	£9.10.0

Single Record Players and Transcription Units also available. Send for list.

## ● HI-FI LOUDSPEAKERS

	Cash Price	Deposit	Monthly Pmts.	Credit Price
<b>GOODMANS</b>				
AXIETTE 8in. ..	£5. 5. 7	£1. 5. 7	6 of 15/10	£6. 0. 7
AXIOM 10in. ..	£6. 5.11	£1.12.11	6 of 18/-	£7. 0.11
AXIOM 201 12in. ..	£10.17. 4	£2. 3. 4	12 of 16/2	£11.17. 4
AXIOM 301 12in. ..	£15. 4. 6	£3. 1. 6	12 of 22/4	£16. 9. 6
AUDIOM 51 Bass 12in. ..	£9. 2. 8	£1.17. 8	12 of 13/9	£10. 2. 8
AUDIOM 61 Bass 12in. ..	£14. 7. 8	£2.17. 8	12 of 21/1	£15.10. 8
TREBAX 100 ..	£6.10. 2	£1.19. 2	6 of 17/8	£7. 5. 2
XO5000 Crossover Unit	£2. 0.11	—	—	—

	Cash Price	Deposit	Mthly/Pmts.	Credit Price
<b>"W.B."</b>				
HF1016 Major 10in. ..	£9. 8. 6	£1.18. 6	12 of 14/2	£10. 8. 6
HF1016 10in. ..	£7. 7. 0	£1.16. 0	6 of 21/-	£8. 2. 0
HF1012 10in. ..	£4.12. 0	£1. 7. 6	3 of 25/-	£5. 2. 0
HF816 8in. ..	£6. 6. 0	£1.10. 0	6 of 18/6	£7. 1. 0
T816 8in. ..	£5. 19.3	£1. 8. 3	6 of 17/8	£6.14. 3
TJ59 Tweeter ..	£1.12. 3	—	—	—
T10 Tweeter ..	£4.12. 9	£1. 7. 9	3 of 25/-	£5. 2. 9
CX3000 Crossover Unit	£1.13. 3	—	—	—
CX1500 Crossover Unit	£2. 2. 0	—	—	—

## ● MARTIN AUDIO KITS

High quality, easy to assemble Hi-Fi Units. Fully Transistorised for mono and stereo/working. All units are assembled and tested and the constructor has only to link together the units chosen for any particular installation. The following mono units are available.  
Unit 1 Input selector 47/6. Unit 2 Pre-amplifier with volume control 37/6.  
Unit 3 Mixer Unit 79/6. Unit 4 Pre-amplifier with tone and volume controls 62/6.  
Unit 5 Main Amplifier 10 watt, 3 ohm output £5.12.6. Unit 7 Main Amplifier 10 watt, 15 ohm output £6.12.6. Unit 6 Power Unit for Unit 5 52/6. Unit 8 Power Unit for Unit 7 55/6. Unit 9A Special pre-amplifier for low output Pick-ups 55/6.  
Units 1, 2, 3 and 4 are available for stereo working at twice the prices shown. Smart plastic escutcheons are available for all combinations of units. Full details in the Martin Illustrated Leaflet, available free.

## WATTS RADIO (Mail Order) LTD

54 CHURCH STREET, WEYBRIDGE, SURREY

Telephone Weybridge 47556

Please note: Postal business only. Callers welcome by appointment.

# EXCEL

in

# ELECTRONICS

## Through this ICS 3-way Training Method:

### 1 MASTER THE THEORETICAL SIDE

From basic principles to advanced applications, you'll learn the theory of electronic engineering, quickly and easily through ICS. That's because each course is set out in easy-to-understand terms.

### 2 MASTER THE PRACTICAL SIDE

ICS show you how to develop your practical abilities in electronic engineering—alongside your theoretical studies. It's the only sure way to success. All training manuals are packed with easy-to-follow illustrations.

### 3 MASTER THE MATHEMATICAL SIDE

To many this aspect is a bitter problem. Even more so because no electronic engineer is complete without a sound working knowledge of maths. But new ICS teaching makes mathematics easier to learn.

Wide range of courses available include:  
Radio/T.V. Engineering and Servicing, Colour Television, Electronics, Electronics Maintenance, Instrumentation and Servomechanisms, Telemetry, Computers, etc.  
NEW! Programmed Course on Electronic Fundamentals.

### EXPERT COACHING FOR:

INSTITUTION OF ELECTRONIC AND RADIO ENGINEERS  
CITY AND GUILDS TELECOMMUNICATION TECHNICIANS  
CITY AND GUILDS SUPPLEMENTARY STUDIES  
R.T.E.B. RADIO/T.V. SERVICING CERTIFICATE  
RADIO AMATEURS' EXAMINATION  
P.M.G. CERTIFICATES IN RADIOTELEGRAPHY

And there are practical "learn as you build" radio courses as well.

Member of the Association of British Correspondence Colleges.

FOR FREE HANDBOOK POST THIS COUPON TODAY

I.C.S., Dept. 151, INTERTEXT HOUSE,  
PARKGATE ROAD, LONDON, S.W.11

NAME .....

ADDRESS .....

OCCUPATION..... AGE..... 4.65

INTERNATIONAL CORRESPONDENCE SCHOOLS

# COLOUR TELEVISION SURVEY

## MANUFACTURERS VOTE FOR NTSC

**T**HE TELEVISION receiver industry in the United Kingdom has given much consideration to the choice of a system of colour television. It is considered that the important factors to be taken into account are those which arise from the point where the signal leaves the transmitting aerial.

The earlier stages concern only a limited number of installations where there are skilled staffs, whereas receivers have to be operated by members of the public, who have no special skills; receivers must, therefore, be simple to operate and as reliable as possible. The system must nevertheless be capable of producing good quality colour pictures on these simple receivers, while the quality of picture displayed on monochrome receivers (i.e. the compatibility) will, for many years, be of the utmost importance.

As a result of its investigations the Industry, represented by The British Radio Equipment Manufacturers' Association (BREMA), is firmly of the opinion that of the three systems currently on trial the NTSC system is the most suitable for a public broadcasting service.

At the meeting of CCIR Study Group XI Sub-Group on Colour Television held in London in February 1964 it was evident that, although the U.K. receiver industry was unanimously convinced of the superiority of NTSC (and indeed this was the preference expressed as the official U.K. view), further documentary evidence would be desirable, and that this evidence should be fully available to other European countries.

It was recognised that there had been suggestions in certain quarters that the public could not operate these receivers easily and that the absence of the hue and colour intensity (saturation) controls in a SECAM receiver was a point in its favour. BREMA therefore decided to conduct its own large-scale trials which have established that this suggestion is a fallacy. The differing types of NTSC receivers produced by a number of U.K. manufacturers were stable and easy to handle, and under normal home-viewing conditions it was found desirable to have hue and colour intensity controls.

### COLOUR PICTURE QUALITY

NTSC has the highest horizontal colour definition potential, while the vertical colour resolution is greater than the other systems (twice that of SECAM) and is not subject to spurious horizontal beat patterns. NTSC has, therefore, the highest potentiality for good colour pictures. It is assumed that the colour pictures transmitted will be of a high standard, and it has been proved that NTSC receivers are fully capable of reproducing them.

NTSC gives the best results on monochrome receivers since it has the lowest colour sub-carrier visibility and an absence of spurious patterns on moving pictures, which can be troublesome on both the other systems.

### CONTROLLABILITY

The recent BREMA home viewing tests have proved that the controls on an NTSC receiver are stable and easy to handle, even by unskilled viewers; although it is perfectly satisfactory to have separate tuning, colour intensity, and hue controls, the NTSC system is flexible and all these controls can be made automatic if desired.

The tuning control (a problem with all systems on u.h.f.) is probably the most important of these, and can be simplified by the employment of automatic frequency control, either with or without push-button channel selection.

The colour intensity control can be automatic with NTSC, but is very useful in correcting for differing ambient lighting conditions and for the preferences of individual viewers; SECAM is considered unsatisfactory in this respect.

The hue control (also normally available with NTSC but not with SECAM) enables the viewer to adjust the picture to his personal preference and to compensate for different tints of ambient lighting or small changes of colour which may occur at the programme source.

The NTSC system is in practice non-critical in terms of i.f. response for both the luminance and chrominance channels; the use of suppressed colour sub-carrier ensures accuracy and stability of white balance. NTSC receivers are less complicated than those for other systems.

### WEAK SIGNAL RECEPTION

Due either to the attempt to receive a signal in an area not yet properly covered by the u.h.f. service or to the use of inefficient receiving aerial installation it has been found that some receivers have to work under exceptionally poor reception conditions. It is therefore essential that the receiver circuits should not fail to operate under such conditions, and that a very low signal/background "noise" ratio should not cause a disproportionate degradation of the picture. Experience shows that the NTSC receiver gives the best results under these conditions.

### COST OF RECEIVERS

Estimates of the costs of the latest SECAM receivers show little difference from the known cost of NTSC receivers, but the new SECAM techniques involve simplifications of circuitry which have so far given disappointing results. The cost of a PAL receiver is significantly more expensive than an NTSC receiver.

The NTSC system offers the greatest scope for improved definition of colour pictures and good compatible performance on monochrome receivers. It is also the most suitable system for use with single-gun tubes should these become available. ★



# NOW ADD F.M. RADIO TO YOUR MARTIN AUDIOKIT SET-UP

with only 3 easy-to-assemble prefabricated units

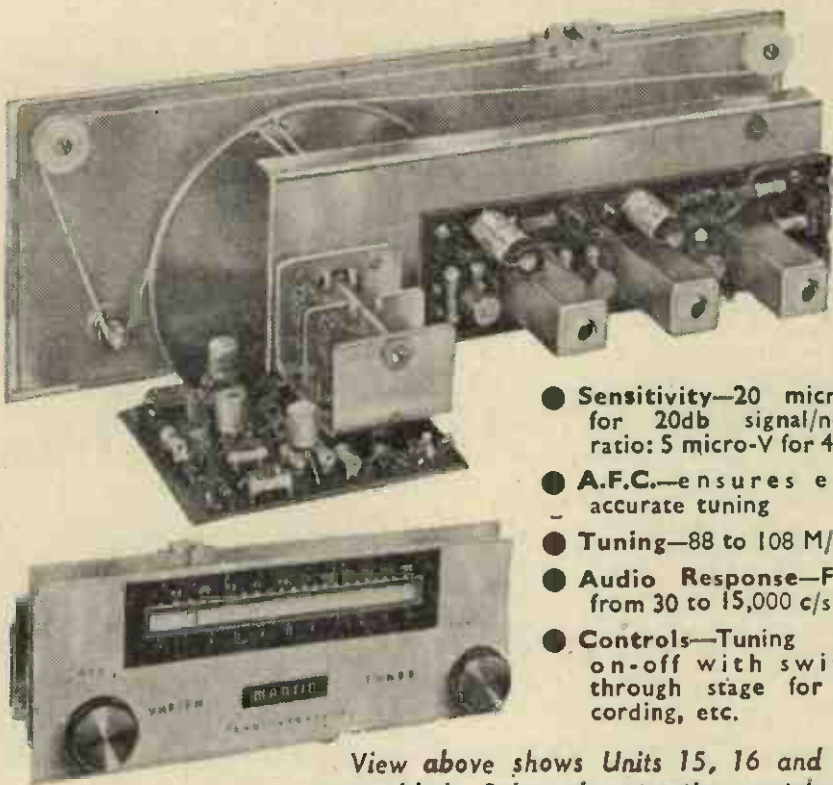

- Sensitivity—20 micro-V for 20db signal/noise ratio; 5 micro-V for 40dB
- A.F.C.—ensures easy accurate tuning
- Tuning—88 to 108 M/c/s
- Audio Response—Flat from 30 to 15,000 c/s
- Controls—Tuning and on-off with switch through stage for recording, etc.

View above shows Units 15, 16 and 17 assembled. Below, the attractive escutcheon.

UNIT 15 £5.12.6 UNIT 16 £5.7.6 UNIT 17 £1.17.6  
 F.M. Head & tuning condenser I.F. Amp. Strip Mounting drive, escutcheon & control.

SUPERB QUALITY FOR VERY MODEST OUTLAY

From Radio and Hi-fi Stocklists

Trade enquiries invited

MARTIN ELECTRONICS LTD., 154/5 High St., Brentford, Middx.

ISLeworth T161/2

The unique and outstandingly successful system developed by Martin Electronics whereby prefabricated transistorised units can be assembled to make your own choice of hi-fi now brings 3 further Units, Nos. 15, 16 and 17 to enable you to build a modern F.M. Tuner of exceptionally good design and performance. Intended primarily for those who have chosen an Audiokit hi-fi set-up, the Tuner may also be used with other good amplifiers if desired. With a few simple connections, you will have a tuner of excellent appearance to please the most critical ear, yet it is surprisingly inexpensive.

A whole range of Audiokit Units is available which you can buy and assemble separately as you wish with ease and complete success. Ask for the Audiokit Leaflet.

MARTIN ELECTRONICS, 154 High St., Brentford, Middx.

Send F.M. Tuner Leaflet  Audiokit Leaflet

(Tick as required)

NAME.....

ADDRESS.....

Pe.4

ONLY 7' 6" LONG!  
**LISTEN**  
 AND ENJOY THE  
 WORLD'S RADIO AMATEUR  
 AND BROADCAST STATIONS WITH  
 THE GREATEST OF EASE !!!

WE HAVE SOLVED your aerial problem for WORLD-WIDE RECEPTION—NO MATTER WHERE YOU LIVE !!!

World Expert Radio Amateur WIBB (U.S.A.) claims the "JOYSTICK" aerial—easier to read stations than with his massive 520' VEE aerial 70' high !!!

ZL4GA, who is probably NEW ZEALAND'S best known Radio Amateur, has scrapped his outstanding 300' 45' high aerial and has worked all Continents on the "JOYSTICK" in under 12 hours.

"CQ" the Radio Amateur's Journal claims "JOYSTICK" better for reception than the world popular DIPOLE (four different receivers used to confirm this decision !)

YOU CAN BE THE PROUD OWNER OF THE WORLD'S MOST VERSATILE & COMPACT "JOYSTICK" COMPLETE RECEIVING SYSTEM FOR AS LITTLE AS

£5.11.0 (Standard system) p. & p. Included  
 or the De Luxe system for £6.11.0 " "

Money Back if not Delighted

Not convinced? Then send for brochure and showers of testimonials to:—

**PARTRIDGE ELECTRONICS LTD.**  
 (Dept. PE)  
 7 SOWELL STREET, BROADSTAIRS  
 KENT

## BARGAIN OFFER

10 Gns.  
 P. & P. FREE



- ★ Very latest BSR UA25 Superlim, 4-speed fully automatic changer.
- ★ Attractive cabinet—solidly constructed with superb finish in two tone rexine, with Vynair and gold/white trim. Size 16" x 15" x 8" and complete with out out motor board.
- ★ Mains transformer—240v AC. Entirely safe and reliable.
- ★ Ready built printed circuit amplifier, with EL84 output and 7" x 4" speaker.
- ★ 30 minutes to build, only 6 connections to make.

Complete kit 10 Gns. Ready built 13 Gns.  
 De-Luxe Model kit 11 Gns. Built 15 Gns.  
 TERMS: C.W.O. P. & P. FREE.

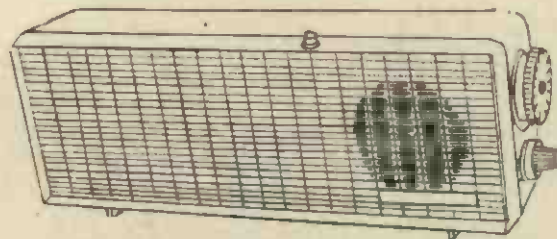

A handsome highly sensitive 7 transistor LW/MW table radio. Fully built and tested. Size 12 1/2" x 4 1/2" x 3 1/2". Takes 4 x U2 batteries. Price £6.19.6 less batteries. P. & P. FREE.

**PEARCE-FIELDING**  
 6b GRAPE LANE, WHITBY, YORKS.

## NEW 1965 RADIO AMATEUR HANDBOOK 1965

by A.R.R.L.

40/-

Postage 2/-

TRANSISTOR MANUAL. 7th ed. Inter: GEC 17/- Postage 1/6.

CLOSED-CIRCUIT TELEVISION HANDBOOK, by L. A. Wortman. 42/- Postage 1/-.

DESIGN OF LOW-NOISE Transistor Input Circuits, by W. A. Reinfelder. 30/- Postage 1/-.

BASIC THEORY & APPLICATION OF TRANSISTORS. U.S. Dept. of Army. 10/- Postage 1/-.

ELECTRONIC ORGAN HANDBOOK, by H. E. Anderson. 35/- Postage 1/-.

PROBLEMS IN ELECTRONICS, by J. C. Higgins. 24/- Postage 1/-.

RADIO VALVE DATA 7th Ed. Compiled by "WW". 7/6. Postage 10d.

COMPLETE CATALOGUE. 1/-.

## THE MODERN BOOK CO.

BRITAIN'S LARGEST STOCKISTS  
 of British and American Technical Books

19-21 PRAED STREET

LONDON, W.2

Phone: PADdington 4185

Open 6 days 9-6 p.m.

**R.S.C.**  
(MANCHESTER) LTD.

MAIL ORDERS  
TO:  
Dept. PE  
54 WELLINGTON  
STREET, LEEDS 1.

Terms C.W.O. or C.O.D. No C.O.D. under £1. Postage 2/9 extra under £2. 4/6 extra under £5. Trade Supplied. S.A.E. with all enquiries please. Personal shoppers welcomed at any of the branches below. Open all day Saturday.

**BRADFORD** (Half-day Wednesday)  
10 NORTH PARADE Tel: 25349

**BRISTOL** 14 Lower Castle Street (Half-day Wednesday) Tel: 22904

**BIRMINGHAM** 30-31 Gt. Western Arcade, opp. Snow Hill Station (No half-day) Tel: CENTRAL 1279

**DERBY** 26 Osmaston Rd., The Spot (Half-day Wed.) Tel: 41361

**DARLINGTON** 13 Post House Wynd (Half-day Wednesday) Tel: 68043

**EDINBURGH** 133 Leith Street Tel: Waverley 5766 (Half-day Wed.)

**GLASGOW** 326 Argyle Street Tel: CITY 4158 (Half-day Tuesday)

**HULL** 51 Savile Street Tel: 20505 (Half-day Thursday)

**LEICESTER** 32 High Street Tel: 56420 (Half-day Thursday)

**LEEDS** 5-7 County (Mecca) Arcade (No half-day closing) Tel: 28252

**LIVERPOOL** 73 Dale Street Tel: CENTRAL 3573 (No half-day closing)

**LONDON** 238 Edgware Road Tel: PADDINGTON 1629 (Half-day Thursday)

**MANCHESTER**  
Large new store now open at 60A/60B Oldham Street Tel: CENTRAL 2778

**MIDDLESBROUGH** 106 Newport Rd. (Half-day Wednesday) Tel: 47096

**SHEFFIELD** 13 Exchange Street, Castle Market Bldgs. (Half-day Thursday) Tel: 20716

**EX. GOV. 2 V. ACCUMULATORS.** 16 A.H. Size 7 x 4 x 2in. Brand new, 4/9 each. Three for 12/6, carr. 5/-.

Jason FMT1 V.H.F./F.M. Radio Tuner design. Total cost of parts including valves, Tuning dial, Escutcheon, etc., £6.19.6.

**FANE HEAVY DUTY HI-FI SPEAKERS**  
12in. 15 ohms. Cast chassis. Exceptionally robust 2in diam. Voice Coil Assemblies.

122/10 20 watt, 5 gns. 122/10A 20 watt, 6 gns.  
122/12 20 watt, 7 gns. 122/12A 20 watt, 8 gns.  
122/14 22 watt, 9 gns. 122/14A 22 watt, 10 gns.  
122/17 25 watt, £11.17.6 122/17A 25 watt, £12.17.6

15in. 15 ohms. Cast chassis. Exceptionally robust 2in. diam. Voice Coil Assemblies.  
152/12 20 watt, 12 gns. 152/12A 20 watt, 13 gns.  
152/14 27 watt, 14 gns. 152/14A 27 watt, 15 gns.  
152/17 35 watt, 16 gns. 152/17A 35 watt, 17 gns.  
"A" indicates dual cone type. 30-17,000 c.p.s.  
Send S.A.E. for leaflets. Terms available.

**R.S.C. G15 15-WATT AMPLIFIER** Suitable for LEAD or RHYTHM GUITAR, 'MIKE', RADIO, TAPE, etc.

High-fidelity push-pull output, Separate bass and treble "cut" and "boost" controls. Twin separately controlled inputs so that two instruments or "mike" and pick-ups can be used at the same time. Loudspeaker is a heavy duty high flux 12in. 20 watt model with cast chassis. Cabinet is well made and finished as Junior Model. Size approx. 18 x 18 x 8in.



Only **19 Gns.** Carr. 10/-  
Send S.A.E. for leaflet. Or DEP. 2 Gns. & 12 mthly pynts of 33/3. (Total 21 Gns.)

**R.S.C. BASS/20 MULTI-PURPOSE AMPLIFIER**  
Ideally suitable for BASS GUITAR and P.A. Work

A highly efficient unit incorporating a massive 15in. high flux loudspeaker specially constructed to withstand heaviest load conditions. Rating 25 watts. Individual bass and treble controls give ample "boost" and "cut". Two high impedance jack socket inputs are separately controlled. All controls are conveniently positioned in a recess on top of the cabinet. Cabinet is of substantial construction and attractively finished in two contrasting tones of Rexine and Vynair. Size approx. 24 x 21 x 13in. Operation from 200-250 v. 50 c.p.s. A.C. mains. Send S.A.E. for leaflet.

Or Deposit £34.6 and 12 monthly payments of 51/6. (Total 32 1/2 Gns.)

**R.A. 12 in. 10 WATT SPEAKERS**  
3 ohm or 15 ohm Excellent value at **59/6**

**R.S.C. GRAM. AMPLIFIER KIT.** 3 watts output. Negative feedback. Controls Vol., Tone and Switch. Mains operation 200-250 v. A.C. Fully isolated chassis. Circuit, etc., supplied. Carriage 3/9. Only **39/9**

**COMPLETE POWER PACK KIT, 19/11**  
Consisting of Mains Trans., Metal Rectifier, Double electrolytic, smoothing choke, chassis and circuit. For 200-250 v. A.C. mains. Output 250 v. 60 mA, 6.3 v., 2 a.

**BASS-MAJOR 30 WATT AMPLIFIER**

A MULTI-PURPOSE HIGH FIDELITY, HIGH OUTPUT UNIT FOR VOCAL AND INSTRUMENTALIST GROUPS  
Eminently suitable for LEAD, RHYTHM & BASS GUITAR and all other musical instruments



- ★ Incorporating two 12in. heavy duty 25-watt high flux (17,000 lines) loudspeakers with 2in. diameter speech coils. Designed for efficiently handling full output of amplifier at frequencies down to 25 c.p.s.
- ★ Dual Cone in second speaker reproduces frequencies up to 17,000 c.p.s.
- ★ Heavily made cabinet of convenient size 24 x 21 x 14in. has an exceptionally attractive covering in two contrasting tones of Vynair.
- ★ For 200-250 v., 50 c.p.s., A.C. mains operation.

- ★ Four jack socket inputs and two independent volume controls for simultaneous connection of up to four instrument pick-ups or microphones.
- ★ Separate bass and treble controls providing more than adequate "Boost" or "Cut".
- ★ LEVEL frequency response throughout the audible range.
- ★ SUPERIOR TO UNITS AT TWICE THE COST.

**39 1/2 Gns.** Send S.A.E. for leaflet OR DEPOSIT of £4.3.0 and 12 monthly payments of £3.8.4. (Total 43 Gns.)  
Carr. 17/6.

**HIGH FIDELITY 12-14 WATT AMPLIFIER TYPE A11**

PUSH-PULL ULTRA LINEAR OUTPUT "BUILT-IN" TONE CONTROL PRE-AMP STAGES

Two input sockets with associated controls allow mixing of "mike" and gram., as in A10. High sensitivity. Includes 5 valves, ECC83, ECC83, EL84, EL84, EZ81. High Quality sectionally wound output transformer specially designed for Ultra Linear operation and reliable small condensers of current manufacture. INDIVIDUAL CONTROLS FOR BASS AND TREBLE "Lift" and "Cut". Frequency response—3 dB 30-30,000 c/s. Six negative feedback loops. Hum level 60 dB down. ONLY 23 millivolts INPUT required for FULL OUTPUT. Suitable for use with all makes and types of pick-ups and microphones. Comparable with the very best designs for STANDARD or LONG PLAYING RECORDS. For MUSICAL INSTRUMENTS such as STRING BASS, LEAD OR RHYTHM GUITARS, etc. OUTPUT SOCKET with plug provides 300 v. 30 mA, and 6.3 v. 1.5 a. for supply of a RADIO FEEDER UNIT. Size approx. 12 x 9 x 7in. For A.C. mains 200-250 v. 50 c.p.s. Output for 3 and 15 ohms speaker. Kit is complete to last nut. Chassis is fully punched. Full instructions and point-to-point wiring diagrams supplied. If required louvered metal cover with 2 carrying handles can be supplied for 18/9. TERMS ON ASSEMBLED UNITS, DEPOSIT 25/- and 9 monthly payments of 25/-. (Total £12.10.0). Send S.A.E. for illustrated leaflet detailing Cabinets, Speakers, Microphones, etc., with cash and credit terms.

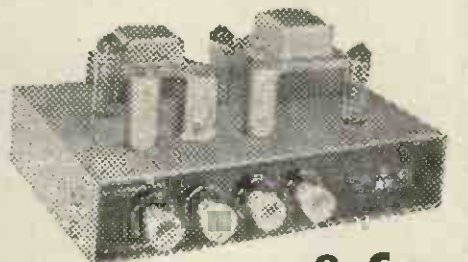

**8 Gns.** Carr. 10/- (Or factory built £10.19.6)

**R.S.C. 4/5 WATT A5 HIGH-GAIN AMPLIFIER**

A highly sensitive 4-valve quality amplifier for the home, small club, etc. Only 50 millivolts input required for full output so is suitable for use with latest High-fidelity Pick-up heads in addition to all other types of pick-ups and practically all "mikes". Separate Bass and Treble Controls give full long-playing record equalisation. Hum level negligible being 71 dB down, 15 dB of negative feedback is used. H.T. of 300 v. 25 mA and L.T. of 6.3 v. 1.5 a. is available for the supply of a Radio Feeder Unit, or Tape-Deck pre-amplifier. For A.C. mains input 200-230-250 v. 50 c/s. Output for 2-3 ohms speaker. Chassis is not alive. Kit complete in every detail includes fully punched chassis (with baseplate) with Gold-Hammer finish and point-to-point wiring diagrams and instructions. Exceptional value at **£4.15.0** or assembled ready for use 25/- extra. Plus 3/6 carr., or deposit 22/6 and 5 monthly payments of 22/6 for assembled unit. (Total £6.15.0).



**R.S.C. CORNER CONSOLE CABINETS**

Polished walnut veneer finish.  
JUNIOR MODEL. Size 20 x 11 x 8in. for 8 x 5in. or 10 x 6in. speakers, £2.9.9.  
STANDARD MODEL. Size 27 x 18 x 12in. for 8 or 10in. speakers, £4.11.9.  
SENIOR MODEL. Size 30 x 20 x 15in. for 12in. Speaker. Suitable Speaker systems below. Only 7 gns.  
R.S.C. BASS REFLEX CABINETS, JUNIOR MODEL. Specially designed for W.B. HF1012 Speaker, but suitable for any good quality 10in. speaker. Acoustically lined and ported. Polished walnut veneer finish. Size 18 x 12 x 10in. Handsome appearance. Ensures superb reproduction for only £3.19.6.



STANDARD MODEL. As above but for 12in. speakers. Size 20 x 15 x 13in. For vertical or horizontal use £5.19.6. Set of legs with brass ferrules, 19/6.

AUDIOTRINE HI-FI SPEAKER SYSTEMS. Consisting of matched 12in. 12,000 line, 15 ohm high quality speaker, crossover unit (consisting of choke, condenser, etc.) and Tweeter. The smooth response and extended frequency range ensure surprisingly realistic reproduction. Standard 10 watt rating. Carr. 5/-. **£4.19.9** Or Senior 15 watt, £6.19.9. Carr. 7/6.

W.B. 'STENTORIAN' HIGH FIDELITY P.M. SPEAKERS HF1012 10 watts rating. Where a really good quality speaker at a low price is required we highly recommend this unit with an amazing performance. Please state whether 3 ohm or 15 ohm required. Only **£4.12.0**

**R.S.C. 30-WATT ULTRA LINEAR HIGH FIDELITY AMPLIFIER A10**

A highly sensitive Push-Pull high output unit with self-contained Pre-amp. Tone Control Stages. Certified performance figures compare equally with most expensive amplifiers available. Hum level 70 dB down. Frequency response ±3 dB 30-20,000 c/s. A specially designed sectionally wound ultra linear output transformer is used with 807 output valves. All components are chosen for reliability. Six valves are used EF86, EF86, ECC83, 807, 807, GZ34. Separate Bass and Treble Controls are provided. Minimum input required for full output is only 12 millivolts so that ANY KIND OF MICROPHONE OR PICK-UP IS SUITABLE. The unit is designed for CLUBS, SCHOOLS, THEATRES, DANCE HALLS or OUTDOOR FUNCTIONS, etc. For use with Electronic ORGAN, GUITAR, STRING BASS, etc. For standard or long-playing records. OUTPUT SOCKET PROVIDES L.T. and H.T. for RADIO FEEDER UNIT. An extra input with associated vol. control is provided so that two separate inputs such as Gram and "Mike" can be mixed. Amplifier operates on 200-250 v. 50 c/s. A.C. mains and has output for 3 and 15 ohm speakers. Complete Kit of parts with fully punched chassis and point-to-point wiring diagrams and instructions. If required perforated cover with carrying handles can be supplied for 19/9. The amplifier can be supplied, factory built with EL34 output valves and 12 months' guarantee, for 14 gns. Send S.A.E. for leaflet. TERMS: DEPOSIT 34/6 and 9 monthly payments of 33/6. (Total 36 gns). Suitable mikes & spkrs. available.

**11 Gns.** Carr. 10/-

ARMSTRONG, TRUVOK, LINEAR, ROGERS, LEAK and JASON EQUIPMENT, GOODMAN'S, W.B. FANE, WHARFEDALE SPEAKERS, GARRARD and GOLDRING T/TABLES. LUSTRAPHONE, GRAMPIAN, RESLO and SHURE 'MIKES' all branches CASH or TERMS.

**12in. 10-WATT HIGH QUALITY LOUDSPEAKER.**

In walnut veneered cabinet Gauss 12,000 lines. Speech coil 3 or 15 ohms. Only £4.19.6. Carr. 5/-. Terms: Dep. 11/3 & 9 mthly. pynts. of 11/3. (Total £5.12.6). 12in. 20 WATT HI-FI LOUDSPEAKERS IN CABINETS. Size 18 x 13 x 10in. Only 7.19.6. Carr. 8/6 Terms: Dep. 17/9 and 9 mthly. pynts. of 17/9.



**SELENIUM RECTIFIERS**

F. W. BRIDGE	24 v. 2 amp. ... 14/9
6/12 v. 1a. ... 3/11	24 v. 20 amp. ... 89/9
6/12 v. 2a. ... 6/11	H.T. TYPES H.W.
6/12 v. 3a. ... 9/9	150 v. 40 mA ... 3/9
6/12 v. 4a. ... 12/3	250 v. 50 mA ... 3/11
6/12 v. 6a. ... 15/3	250 v. 60 mA ... 4/11
6/12 v. 10a. ... 26/9	250 v. 80 mA ... 5/11
6/12 v. 15a. ... 35/9	250 v. 250 mA ... 11/9
<b>CONTACT COOLED.</b> 250 v. 75 mA, F.W. (Bridge), 10/11. 250 v. 50 mA, F.W. (Bridge), 8/11. H.W. 250 v. 60 mA 5/11.	

### Solderless Terminal Fastener

S. H. Collett Manufacturing Co. Ltd., 347-349, Goswell Road, E.C.1.

An ingenious tool for wire stripping, cutting and crimping is available from the above mentioned firm. Known as the Collett 3-way Crimper, it is handy for those who experience trouble soldering terminal connectors to wires.

The crimper is priced at 48s.

# NEW PRODUCTS

### Listen In Comfort



Amplivox Ltd., Beresford Avenue, Wembley, Middlesex.

A new moving coil version of the Jetlite headset has foam air cushions which enable it to be worn for very long periods in comfort without contracting headaches due to pressure on the ears. The cushions also exclude extraneous room noises so providing complete aural privacy and good quality sound reception.

The boom arm is adjustable for length and 320° angle of rotation enables the wearer to select right- or left-hand usage.

Each earphone is low impedance (200 ohms) providing an excellent frequency response throughout the audio range. They can be supplied wired for either monaural or stereo operation; the boom arm microphone is optional.

The price of the complete headset is £12 6s. 8d. list price. The headphone without boom is £9 1s. 6d. list price.

### New High Power Batteries

Ever Ready Co. (Great Britain) Ltd., Hercules Place, London, N.17.

Our photograph shows the new range of round cell high power batteries recently announced by Ever Ready.

The standard "U" type batteries are ideal where intermittent use, moderate powers and high voltage are necessary, such as receivers and torches. But motor-driven, portable equipment really needs higher capacity batteries capable of delivering larger currents for longer periods with less voltage drop.

The new "HP" round cell batteries have been specially designed to fulfil these needs. They have a paper separator—much thinner than the electrolyte wall in the conventional paste version—and high grade electrolytic manganese dioxide, which has very fine depolarising properties.

At the higher current levels the HP2 will last more than six times as long as the U2.





### F.M. Tuner Construction Units

Martin Electronics Ltd., 154/155, High Street, Brentford, Middlesex.

Being more attractive and simple to construct the "build-it-yourself" kits are now becoming more popular. Due mainly to the increasing use of printed circuit and transistor techniques, one can now build a unit that has a truly professional finish.

Our photographs show a new f.m. tuner by Martin Electronics. The tuner, like all their kits, comes in unit form and there are three such units in this set. Powered by 12 volts at 12mA it has a sensitivity of 2 microvolts for 20dB signal/noise ratio; 5 microvolts for 40dB signal/noise ratio. The i.f. rejection is better than 50dB and image rejection is better than 20dB. Drift is less than 25kc/s and an automatic frequency control is incorporated for accurate tuning.

The tuning range is from 88 to 108 Mc/s and the audio response is flat from 30 to 15,000 c/s enabling 50 microsecond de-emphasis. Output voltage is 100mV into high impedance (100,000Ω) on average reception.

The price of the tuner is £12 17s. 6d., or can be purchased in separate units as follows, f.m. head complete with tuning capacitor £5 12s. 6d.; i.f. amplifier strip £5 7s. 6d.; and the escutcheon drive, mounting assembly and controls £1 17s. 6d. These prices include purchase tax.

### New Tape Recorder

Debenhams Electrical & Radio Distribution Co. Ltd., Eastbrook Road, Eastern Avenue, Gloucester.

A new tape recorder from Bang & Olufsen (Denmark) Ltd, designed for the user who owns a hi-fi system and desires a good recorder to complete the set-up is now available from the above firm.

The Beocord 1500 has no mixing facilities or output replay amplifier but does feature meter recording level indicators. Provision is also made for any corrections to be carried out to stereo balance on recording or replay. The Beocord 1500 retails at 89 guineas.

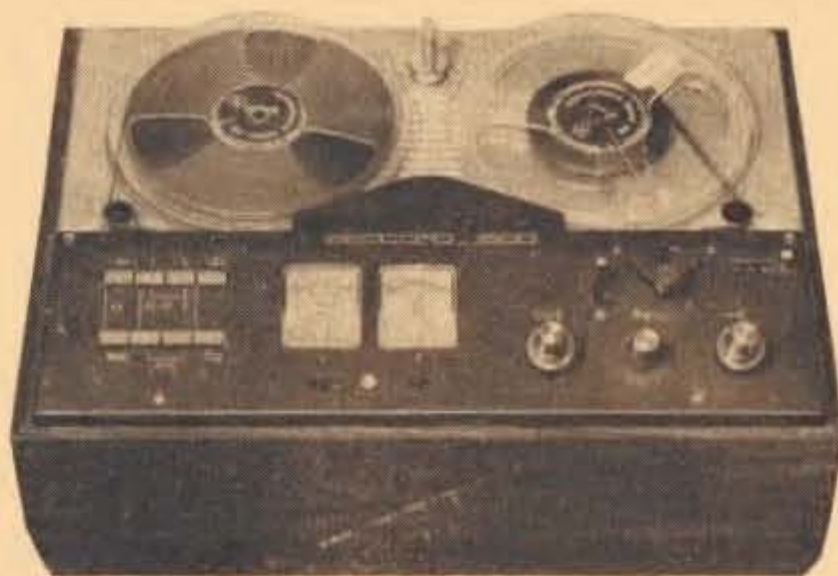

### Mullard Digitrons

In last month's article "Electric Clock with Digital Display" the digitron type number was incorrectly given as G 530M. This should read Z520M (available through retailers).

A transformer designed specially for miniature work has just been announced by Belclere. Known as type "ES" it occupies less than one cubic inch and weighs less than two ounces.

Ideal for transistor work the transformer is rated at 110V or 240V 50c/s primary and 12V at 40mA secondary. The transformer is vacuum impregnated with thermosetting varnish, epoxy resin, or high melting point wax. Fixing is by pins, for circuit boards, or wrap-over clamp. Alternatively it can be supplied in a mumetal screening can 1½in high × 1½in diameter with ⅜in hollow fixing bush at one end.

### Miniature Mains

### Transformer

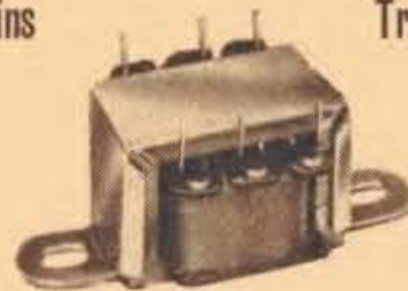

The Belclere Co. Ltd.,  
385/387, Cowley Road, Oxford.

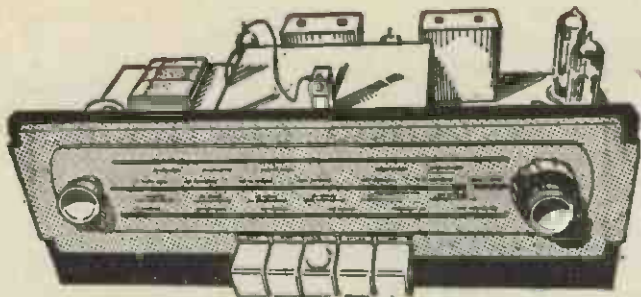

**BRAND NEW  
AM/FM  
(V.H.F.)  
RADIO  
GRAM  
CHASSIS AT  
£13.13.0  
(Carriage Paid)**

Chassis size 15 x 6 1/2 x 5 1/2 in. high. New manufacture. Dial 14 1/2 x 4 in. in 2 colours, predominantly cream. 200-250v. A.C. only. Pick-up, Ext. Speaker, Ae., E., and Dipole Sockets. Five push buttons—OFF, I.W., M.W., F.M. and Gram. Aligned and tested. O.P. Transformer, Tone Control. 1000-1900 M.; 200-550 M.; 88-98 Mc/s. Valves EZ80 rect.; ECH81, EF89, EABC80, EL84, ECC85. 3-ohm speaker required. Speaker 8 x 5 in. and Cabinet to fit chassis (table model), 47/6 (post 5/-). 10 x 6 in. ELLIPTICAL SPEAKER 25/- to purchasers of this chassis. TERMS: (Chassis) £3.10.0 down and 5 monthly payments of £2.4.0. Cheap Room Dipole for V.H.F., 12/6. Feeder 6d. per yard. ALTERNATIVE DESIGN. I.W. 1000-1900 M.; S.W. (9-15 Mc/s); M.W. 190-475 M.; V.H.F. 87-100 Mc/s; Gram position. Otherwise similar to above chassis. Price £15.15.0 (carr. paid). TERMS: £3.10.0 down and 6 monthly payments of £2.4.0. Total H.P.P. £16.14. Circuit diagram 2/6.

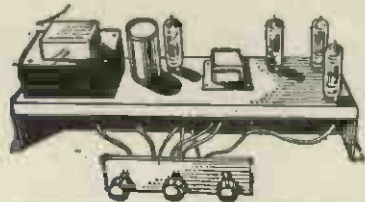

**PUSH-PULL O.P. AMPLIFIER  
£5.5.0 (6/- Carr.)**

Brand new 200-240 A.C. mains Bass, treble and vol. controls, with valves EZ80, ECC83 and 2-EL84 giving full 8 w. Chassis 12 x 3 1/2 x 3 1/2 in. With o.p. trans for 2-3 ohm speaker. Front panel (normally screwed to chassis) may be removed and used as "flying panel".

**LAFAYETTE BRAND TAPE**

MYLAR BASE	
7in. Stand. play, 1,200ft. ....	12/6
7in. Long play, 1,800ft. ....	19/6
5in. Double play, 1,200ft. ....	15/-
5in. Double play, 1,800ft. ....	22/6
7in. Double play, 2,400ft. ....	25/-
3in. Triple play, 450ft. ....	12/6
3 1/2in. Triple play, 600ft. ....	14/-
4in. Triple play, 900ft. ....	22/6
5in. Triple play, 1,800ft. ....	42/6
5 1/2in. Triple play, 2,400ft. ....	55/-
7in. Triple play, 3,600ft. (unboxed)	75/-

**FULLY GUARANTEED AT RECORD  
LOW PRICES**

ACETATE BASE	
5in. Stand. play, 600ft. ....	8/-
7 in. Stand. play, 1,200 ft. ....	11/-
5in. Long play, 900ft. ....	10/-
5 1/2in. Long play, 1,200ft. ....	12/6
7in. Long play, 1,800ft. ....	15/-

MESSAGE TAPES	
3in. Stand. play, 150ft. ....	3/6
3in. Long play, 225ft. ....	4/11
3in. Double play, 300ft. ....	7/6

Postage 1/- per reel (4 or more post free).

**"REALISTIC" 'SEVEN'**

7 Transistor Superbet. 350 Milliwatt output, 4-inch speaker. All components mounted on a single printed circuit board size 5 1/2 x 5 1/2 in. in one complete assembly. Plastic cabinet with carrying handle, size 7 x 10 x 3 1/2 in. External socket for car aerial. Ferrite rod aerial. Price for the complete parcel including Transistors, Cabinet, Speaker, etc. and full Construction Data: £5.19.8. P. & P. 4/6. PP9 Battery 3/9. Data and instructions separately 2/6. Refunded if you purchase the parcel. Any parts supplied separately.



**4 TO 5 WATT HIGH GAIN AMPLIFIER**

Only £5.15.0. (P. & P. 5/-). Suitable for record player, radio, tape after equalisation. Double wound mains transformer. Fully built. For A.C. mains of 200/250 v. 14 d.b. neg. feedback. Controls are volume (on/off), treble and bass. Contact cooled metal rectifier (bridge); ECO 83 and EL 84 valves. Output for 3 ohm speaker. Chassis Size 6 1/2" x 6" (over spindle), overall height, incl. valves, 5 1/2". High and low input by Phono sockets.

**GUITAR AMPLIFIER — 8 WATT**

Chassis as for our Push-Pull Amplifier. Valves EZ80, 2 x EL84, 6 BR8. Output for 3 and 15 ohms. Bass, treble and vol. controls. On-off switch. Input 200-240 v. A.C. Also suitable for pick-up, etc. OUR PRICE £5.5.0. (6/- P. & P.)

**4-TRANSISTOR MINIATURE PUSH-PULL  
AUDIO AMPLIFIER HIGH IMPEDANCE**

PRINTED CIRCUIT. 4in. x 2 1/2in. 1 1/2in. over transformers. Output for 3-ohm speaker. Suitable for microphone, record player, guitar and intercom. 9 volt battery required. Frequency range 100 cps. to 25 Kcps. Push-pull output class B. Instruction sheet provided. Fully wired ready for use. Two types. 200 mw. 35/-; 1/2 watt, 41/- P. & P. 2/6.



**4-SPEED AUTOCHANGERS**

	Carr. 5/- each
BSR-UA14 .....	£5.19.8
GARRARD AUTOSLIM .....	£6.10.0
STEREO .....	£7.5.0
AUTOSLIM DE LUXE AT6 .....	£10.19.8
STEREO .....	£11.10.0

**2 1/2-WATT AMPLIFIER**

Our price ONLY 39/6 (post 5/-); a few only; valves EF91 and ECL82 with metal rectifier: 6 x 4 x 1 1/2 in. high (5in. over ECL82). Mains trans. and o.p. with vol. and tone controls; on-off; co-ax. input.

**TAPE RECORDER AMPLIFIER**

Fully built. Front panel 12 1/2 x 3in. Chassis size 10 1/2 x 5 x 4in. Valves EF86, ECC83 and 2EL84. Controls (1) MIC. Vol. (2) Tuner/P.U. Vol. (3) Play back or monitor. (4) Tone, 2 jack sockets for Tuner/P.U. and MIC-switch for superimpose. Separate power pack containing transf. & rectifier. For Collaro studio deck only. Price £8.14.0 (6/- P. & P.).

ALL ITEMS ARE NEW AND FULLY BUILT UNLESS OTHERWISE STATED. TESTED BEFORE DESPATCH. Delivery by return. Terms available on items over £5. Send 6d. (stamps will do) for 20-page illustrated catalogue. C.O.D. 2/6 extra. ALL ITEMS GUARANTEED 12 MONTHS. VALVES 3 MONTHS. Regret overseas orders cannot be executed.

**GLADSTONE RADIO**

66 ELMS ROAD, ALDERSHOT, Hants.  
(2 mins. from Station and Buses).

(CLOSED  
WED.)  
Aldershot 22240

ADVERTISEMENT

THE FUTURE FOR ELECTRONICS

Most people agree that this is the age of electronics and automation. Many know that their own job may eventually be replaced by some automated machine.

Slowly but surely, electronically controlled machines are taking over from the typesetter, bookkeeper, lathe and drill operator, office clerk and many other trades that were considered beyond the influence of electronics less than a few years ago.

In the U.S.A. where this science is quite advanced, literally thousands of jobs are disappearing every week. In England, thank goodness, the trend has not been quite so rapid, though of course the same impact will eventually be felt.

What should the average man do about this situation? Some will do nothing and wait until they are unemployed, while others will of course take action before it is too late.

There is a solution for those who have a need for retraining and the desire to take action! In fact the old saying "If you can't beat 'em" applies to the menace of automation, more than to anything that has threatened the liberty of man since King John signed Magna Charter!

Now, anyone can start to learn electronics easily through the study of our course of 36 lessons. The lessons are crystal clear, practical, easy to master and use. Early lessons make fundamentals clear even to the beginner, while other lessons will give you the practical knowledge of an expert!

This course actually compares favourably with some costing ten times as much. You save because you receive all the lessons at one time and are not required to purchase equipment you may not need.

This is a real home study course that has been bound into one giant eight by eleven inch, 216 page manual. Each page is divided into two columns. A wide column features the text, while a narrow column at the side has the instructor's comments, helpful suggestions and additional pictures to simplify the more difficult parts.

Everyone can benefit from this practical course, including those who's main interest may be nothing more than a desire to have a clearer appreciation of electronics as it relates to their present work or hobby.

In addition to the course, Sim-Tech offer the opportunity to take an examination in radio and electronics to those who have studied the electronics course and feel that they have attained a sufficiently high standard of proficiency. There is an additional fee of one guinea for the examination (which is entirely optional). Further details are given with each course ordered.

Sounds good doesn't it, but how can you be sure that you are not wasting your money? Well, we will send you this course on the understanding that you must be convinced this is the best value you have ever seen in electronic training, otherwise you may return the course (or have your money refunded if sent with order) after you have examined it in your own home for a full seven days.

The price? Only 39/6d plus postage 1/6d. Terms? Why, of course! See coupon.

Open to all permanent residents of the U.K. excluding Ireland.

SPECIAL! SEND CASH WITH ORDER AND WE WILL INCLUDE A FREE 70 PAGE BOOK ON TELEVISION OR RADIO FAULT FINDING. These books are regularly sold at 5/- each and are loaded with useful information. By sending cash you reduce bookkeeping and other costs, which savings we are able to pass back to you!

--- FREE TRIAL OFFER! ---

To: Sim-Tech Book Company, Dept. EL6, Gater's Mill, West End, Southampton, Hants.

Please send your ELECTRONICS COURSE for a full seven days' trial. If not delighted, I may return the course post paid without further obligation on my part. Otherwise I will pay cash price, OR 10/9 fortnightly until purchase price of 41/- plus 2/- service charge has been paid.

- Tick here if enclosing full purchase price.
- Please send me  FREE. RADIO FAULT FINDING BOOK.
- OSCILLOSCOPE BOOK.

Amount enclosed £ \_\_\_\_\_

understand that you will refund this money in full if I am not 100% satisfied. Overseas customers please send full amount (including Ireland).

NAME \_\_\_\_\_

ADDRESS \_\_\_\_\_

City \_\_\_\_\_ County \_\_\_\_\_



# THINKING TAPE? THINK Brenell

If you're thinking in terms of tape recording, then the Brenell deck and complete recorders should be uppermost in your mind. The reliability, the versatility and the quality of manufacture are seldom equalled in other tape recorders (even in those costing much more).

**How many can equal or better this specification?**

4 record/playback speeds  $1\frac{7}{8}$ ,  $3\frac{3}{4}$ ,  $7\frac{1}{2}$  and 15 ips • 3 motors (capstan motor-hysteresis synchronous) • low 'wow and flutter' content (0.05% at 15 ips, 0.1% at  $7\frac{1}{2}$  ips, 0.15% at  $3\frac{3}{4}$  ips and 0.25% at  $1\frac{7}{8}$  ips) • double-gapped ferrite erase head to minimise erase noise • narrow-gapped record/playback head to give extended frequency response • pause control • superimpose control •  $8\frac{1}{4}$ " dia. reels (to take  $10\frac{1}{2}$ " dia. N.A.B. reels at extra cost) • fast rewind • digital rev. counter.

**Mark 5  
Series 2  
Deck**

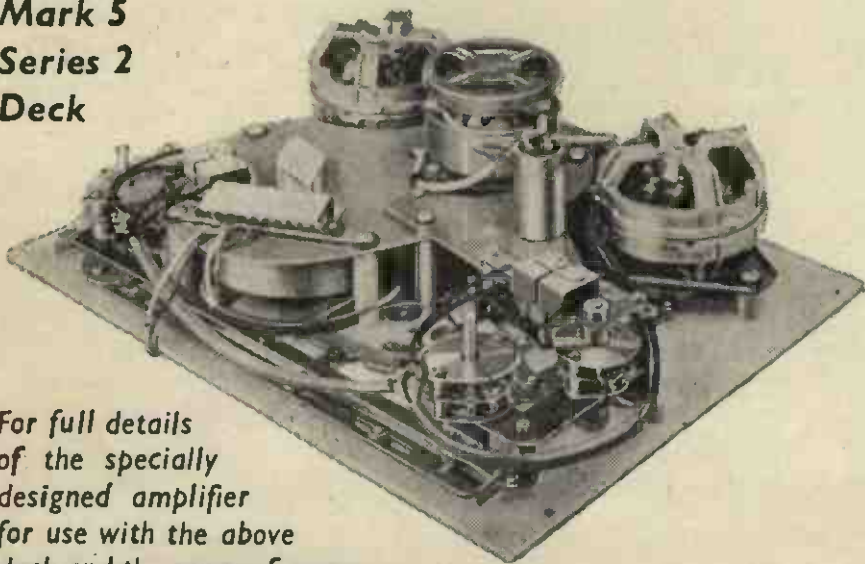

For full details of the specially designed amplifier for use with the above deck and the range of mono and stereo recorders, write or telephone the sole manufacturers:

## Brenell

**BRENELL ENGINEERING CO. LTD.**  
231-5 LIVERPOOL ROAD, LONDON, N.1  
Telephone: NORth 8271 (5 lines)

GD840

# RST

Cordially invite  
Practical Electronics  
readers to try our  
unsurpassed

## VALVE MAIL ORDER SERVICE

Vast quantities of modern and obsolete fully guaranteed valves available from stock at very moderate prices. Send S.A.E. for Full lists, Callers welcome

## SPECIAL 24 HOUR EXPRESS MAIL ORDER SERVICE

AZ31	12/6	EF98	10/-	PL82	7/6	X79	40/-	6K8GT	9/6
DAF91	4/6	EF183	9/-	PL83	7/6	IR5	5/6	6L6G	7/6
DAF96	6/6	EF184	8/-	PL84	7/-	IS5	4/6	6Q7G	6/-
DF91	3/-	EL33	17/6	PY32/3	10/-	IT1	3/-	6Q7GT	10/-
DF96	6/6	EL41	9/-	PY81	6/-	3T4	5/-	6U5G	7/6
DK91	5/6	EL42	9/-	PY82	5/6	3V4	7/-	6V6G	4/-
DK92	7/-	EL84	5/9	PY83	7/6	5U4G	4/-	6V6GT	7/6
DK96	7/6	EL95	9/6	PY800	8/6	5V4G	9/-	6X4	4/6
DL92	5/-	EM80	8/-	PZ30	12/6	5Y3G/GT	6X5G	5/-	
DL94	7/-	EM81	8/-	SP61	3/-		8/6	6X5GT	8/6
DL96	6/6	EM84	8/-	U14	9/-	6A7	12/6	6/30L2	12/6
EABC80	5/6	EY51	7/6	U25	10/-	6A8	8/6	7B6	21/-
EAF42	8/6	EY86	7/-	U26	10/6	6AL5	3/6	7B7	9/6
EB91	3/6	EZ40	7/-	U191	13/6	6AM6	4/-	7C5	10/6
EBC41	8/-	EZ41	7/-	U301	18/6	6AQ5	6/6	7C6	9/6
EBF80	7/6	EZ80	5/6	U801	19/6	6AT6	4/6	7H7	6/-
EBF83	8/-	EZ81	5/6	UABC80	5/6	6B8G	2/6	7S7	18/-
EBF89	7/6	GZ32	12/6	UAF42	8/6	6BA6	5/6	7Y4	6/6
ECC81	4/-	HL41DD	8/-	UBC41	8/-	6BE6	5/6	8D3	4/-
ECC82	5/-		12/6	UBF80	7/6	6BJ6	8/-	10F1	10/-
ECC83	5/6	KT66	17/6	UBF89	7/6	6BR7	10/6	12AU7	5/-
ECC84	6/6	KT81	10/6	UCH42	8/6	6BR8	12/6	12AX7	5/6
ECC85	6/-	KTW61	7/-	UCH81	7/-	6BW6	9/-	12BA6	7/6
ECH35	12/6	MU14	17/6	UCL82	8/6	6BW7	9/-	12BE6	7/6
ECH42	8/6	N78	22/6	UCL83	9/-	6C4	3/6	12K7GT	5/-
ECH81	7/-	OZ4	5/-	UF41	7/6	6C5GT	8/-	12K8GT	10/-
ECH83	5/9	PCC84	6/-	UF89	7/-	6CD6G	25/-	12SQ7	12/-
ECL80	6/6	PCC89	8/9	UL41	7/6	6CH6	10/-	19AQ5	8/-
ECL82	8/6	PCF80	7/-	UL84	6/-	6C6	5/6	25Z4	7/6
ECL86	8/6	PCF86	9/6	UY41	7/6	6F6	5/9	35L6GT	8/6
EF41	7/6	PCL82	7/6	UY85	5/6	6H6	2/-	35W4	6/6
EF80	5/-	PCL83	9/-	VP4B	17/6	6J5G/GT	35Z4		6/6
EF85	5/-	PCL84	7/-	VR150/30			5/6	50C5	8/6
EF86	7/-	PCL85	7/6		7/-	6J7G	5/-	80	7/6
EF89	8/-	PCL86	10/-	WB1M	6/-	6K7G	2/-	90CG	25/-
EF91	4/-	PL36	11/6	X61M	13/6	6K7GT	2/6	99CV	25/-
EF92	4/-	PL81	7/6	X78	26/-	6K8G	4/-	807	9/6

### BRAND NEW TRANSISTORS

OC35	10/-	OC72	8/-	OC81D	5/-
OC42	6/-	OC74	8/-	OC81m/pr	12/6
OC44	5/-	OC75	8/-	OC82	8/-
OC45	5/-	OC77	8/-	OC82D	6/-
OC71	5/-	OC81	5/-	OC170	6/-

### SILICON RECTIFIERS

400 volts 350 mA ... .. 7/6 each

### METAL RECTIFIERS

RM1	7/6	14A86	23/-	16RD 2-2-8-1	12/-	(FC142)	
RM2	8/-	14A97	26/-	16RE 2-1-8-1	10/-	(FC150)	
RM3	10/-	14A100	28/-	18RA 1-1-8-1	5/-	(FC118)	
RM4	17/6	14RA 1-2-3-2	21/-	(FC301)	18RA 1-1-16-1	7/-	(FC116)
RM5	19/6	14RA 1-2-8-3	25/-	(FC31)	18RD 2-2-8-1	16/-	(FC124)

### SETS OF VALVES

IR5, IS5, IT4, 354, 3V4	...	...	...	Set of 4,	17/-
DAF91, DF91, DK91, DL92, DL94	...	...	...	Set of 4,	17/-
DAF96, DF96, DK96, DL96	...	...	...	Set of 4,	25/-

**TERMS OF BUSINESS C.W.O. or C.O.D.**

**4/2 PACKING CHARGE ON ALL C.O.D.**

**ORDERS. POSTAGE 6d. per VALVE**

## RST VALVE MAIL ORDER CO.

211a, STREATHAM ROAD, MITCHAM, SURREY

Telephone: MITcham 6202 & 6771

Mon. - Sat. 9 a.m. - 5.45 p.m. Wednesday 9 a.m. - 1 p.m.

Lunch 1.30 p.m. - 2.30 p.m.

# Readout —

## A SELECTION FROM OUR POSTBAG

### Modules ahead

Sir—I would first like to thank R. V. Walley, of Bristol for his suggestion concerning the "in-betweens". I find PRACTICAL ELECTRONICS an extremely well-informed magazine yet I do not possess the ability to construct many of your designs.

In the first edition of your magazine, I found the Transistor Morse Oscillator which I successfully undertook. Could we please have some more articles of this nature?

G. Chisholm (aged 15),  
Rawmarsh,  
Yorkshire.

*We're sure this issue will keep you busy for quite a time.*

### Printed circuits . . . for

Sir—I was horrified and astounded when I read J. E. Brown's letter decrying printed circuits in your February issue.

Whilst I agree with him that few amateurs would care to "mess about with chemicals" to produce them, he is quite wrong to say that there is a "lack of availability on the market."

My own firm have been producing "one off" printed circuit boards for the home constructor for the past year. And advertisements have appeared in PRACTICAL ELECTRONICS from time to time.

I cannot understand why Mr. Brown dislikes printed circuits, for they are by far the best method of constructing transistorised equipment. After all, you must have somewhere to mount your transistors, and if that is going to be a piece of insulating board, you may as well let it carry the wiring as well.

Printed circuits also make equipment lighter and more compact, there is less likelihood of errors during construction, and greater stability is obtained due to the fact

that all the vital components are in exactly the position the designer intended.

Judging by the orders we have received from amateurs Mr. Brown is clearly in the minority, and I trust that he will soon see the error of his ways.

G. K. Sutherland,  
Llangefni,  
Anglesey.

### . . . and against

Sir—Re "Down With Printed Circuits?" (*Readout* in the February issue of PRACTICAL ELECTRONICS) I must heartily agree with J. E. Brown. Also from the TV service engineer's point of view they constitute a load of trouble. Quite apart from ordinary component breakdown, distortion of the Paxolin board results in fractures of copper conductor strips, bad plug connections arise due to corrosion or folding over of contacts, etc.

Paul S. Willaret,  
Radcliffe,  
Lancs.

### . . . it's all in the mind

Sir—I would like to take up some of the comments made in *Detached Particles*, where it is suggested that a case can be made out for conventional current flow direction on the basis of hole conduction in semiconductors.

I must point out that this is not really so, because the idea of hole conduction is merely a useful method of considering a particular type of electron flow. The hole, or apparent positive current carrier, *seems* to move from positive to negative, but the only physical object which has moved is an electron, in the other direction.

The positive charges are due to the nuclei of the atoms, which are not free to move.

H. N. Rutt,  
Hatfield,  
Herts.



### Guitar for £6

Sir—Please find enclosed photograph (see picture at top of page) of an electronic guitar as made to your specifications in the January issue.

My son and I have not yet had time to fit the controls which are outlined in the February issue.

The guitar is a great success, and we have played it through a small amplifier direct.

Needless to say my son is delighted with it and the total cost is as follows:

	£	s.	d.
Pick-up .. ..	3	0	0
Strings .. ..	1	10	0
String winders ..	15	0	
Varnish .. ..	6	0	
Fret wire .. ..	2	0	
Araldite Glue ..	6	0	
<b>Total .. ..</b>	<b>5</b>	<b>19</b>	<b>0</b>

The wood was mostly odds and ends scrounged here and there.

S. W. Burrows,  
Wilmslow,  
Cheshire.

### Enlarger controller

Sir—I am an amateur photographer and interested in making an automatic enlarger exposure controller (not a timer).

# Readout—

## A SELECTION FROM OUR POSTBAG

continued

I have found an old American circuit diagram using valves. Can this circuit, or a circuit working on the same principle, be constructed using transistors with battery power supply?

I have been given a photocell type OCP71: could this be used in such a circuit?

B. J. Solloway,  
Chasetown,  
Nr. Walsall,  
Staffs.

*This is one of the few times when the low impedance of the transistor is a disadvantage. The OCP71 you mention could not be used easily, as the current this device would deliver, when illuminated by reflected light from the baseboard of an enlarger, is almost the same as that when it is not illuminated at all.*

*The problem of making a timer which works as you suggest is one I am at present investigating. In the very near future I hope to be able to provide a suitable, proved circuit.—G. J. Flanagan.*

### Intercom unit

Sir—Last night I had cause to wire up another amplifier for my Two-way Intercom published in the December 1964 issue. I then discovered an error in the blueprint circuit.

Please note that R6 should be  $3.3k\Omega$  and NOT  $33k\Omega$  as shown on the blueprint. As this will almost certainly lead to damage to the output transistor, I can only offer my apologies to all concerned and hope I have saved some readers from disaster.

K. Berry,  
Barton-on-Sea,  
Hants.

### Plight of the "bumble bee"

Sir—I suppose I am rather like the bumble bee. Aerodynamic theory says that with his fat body and small wings he can't possibly fly. But he knows nothing about aerodynamics—so he just goes on flying.

For a good few years now I have happily knocked up speaker enclosures without knowing a thing about it, and so far as I can tell they have all worked perfectly.

But now, having progressed too far with a slightly more complicated project to be able to alter it, I am stopped dead in my tracks by an article on the subject by K. F. Russell in your current issue (see Jan.-Feb.).

Oh dear! All those graphs and diagrams and all that stuff about resonance, frequencies, reflex tuning, acoustic resistance and old uncle Tom Cobleigh and all! Way, way above my poor befuddled head!

What I am doing is trying to improve the sound with my TV receiver by providing a separate source with a Jason JTV2 tuner, Sinclair X10 amplifier,  $15\Omega$  to  $3\Omega$  transformer and three speakers.

I have bought inexpensive mass-produced speakers: a  $13\frac{1}{2}\text{in} \times 8\text{in}$  elliptical, a  $10\text{in} \times 6\text{in}$  middle range unit and a  $2\frac{1}{2}\text{in}$  tweeter. These are used in conjunction with a cheap Japanese variable crossover.

For these I have built a floor-to-ceiling enclosure behind the TV receiver. The external dimensions of this are  $7\text{ft } 9\text{in} \times 11\text{in} \times 5\text{in}$ . It is made of softwood and the internal capacity is about  $1.8\text{cu ft}$ .

Until I read Mr. Russell's article I was merely going to line it with carpet underfelt and drill a couple of holes in it with the vague idea that this was a good idea to avoid air pressure inside. Now I realise that this is a most complex procedure.

Please, how do I determine the correct reflex opening for the speakers and enclosure I have described?

P. H. Marsh,  
Warrington,  
Peterborough.

*We should first like to reassure you that one can obtain satisfying sound reproduction with quite ordinary speakers in enclosures built without mathematics. It is when we wish to achieve reproduction which is close to the original sound that we need to start with loudspeakers capable of a smooth response throughout the audible range, and these tend to be expensive.*

*The application of elementary scientific principles ensures that we do get the best from our speakers, and a cabinet made in this way costs no more.*

*As regards the enclosure described, this is a most unusual shape, and we would not recommend it. The main*

*trouble is that it is shaped rather like an organ pipe, and will tend to resonate as such. If it is open at one end for the bass unit, and closed at the other, it will resonate at about  $26\text{c/s}$ . If it is open at both ends, it will resonate at  $73\text{c/s}$ . In both cases, there will be secondary resonances as the air column breaks up into different modes of vibration, this will give rise to a colouration of sound which can be very disturbing. In addition to this, the rather shallow dimension of  $5\text{in}$  can give rise to severe "honking".*

*Our recommendation would be as follows. The tweeter unit should be put at one end of the cabinet, in its own airtight compartment, about  $5\text{in}$  or  $6\text{in}$  long. If a crossover for the middle unit is chosen above  $1,000\text{c/s}$ , the middle unit should be placed, again in its own compartment, which can be about  $8\text{in}$  long at either end of the remaining length of the enclosure. The bass unit should be placed away from the ends and the middle of the remaining enclosure, preferably about a third of the way along.*

*The whole of this enclosure should be loosely filled with some light absorbent material such as bonded acetate fibre, cotton wool or fibre glass, and a tuning slot of  $9\text{in}$  long by  $\frac{3}{4}\text{in}$  wide should be cut, the position of this not being critical. It would, however, tend to reduce resonances if the slot were to run parallel to the longer dimension of the enclosure.*

### Reversed meter leads

Sir—With reference to the High Impedance Voltmeter described in the January issue.

I would like to know if any damage would be done to the transistor if the test leads were connected round the wrong way, and if this is so, would it be possible to place a diode in the positive test lead.

D. J. Binnington,  
Saint Osyth,  
Clacton-on-Sea,  
Essex.

*There is no need to include a diode in series with one of the test leads of the High Impedance Voltmeter as the base-emitter junction of the transistor constitutes such a diode.*

*If the test leads are connected the wrong way round, this "diode" is reversed biased and little current can flow anyway. However, as you may have observed, a reverse deflection of the meter occurs when the leads are reversed and this may damage the meter.*

*When taking readings, always start on a high range and switch down progressively. This will protect the meter as any errors in connecting the leads will be obvious.—R.E.F.S.*



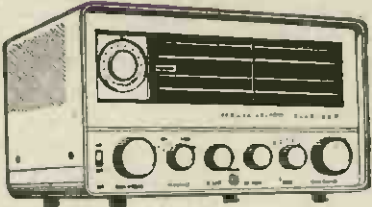

### LAFAYETTE HA-63 COMMUNICATION RECEIVER

7 valves plus Rectifier. 4 Bands. 550 kc/s-31 Mc/s. "S" Meter-BFO-ANL-Bandspread Tuning. 200/250v. A.C. Brand New 24 Gns. Carr. Paid.

### STAR SR.40 COMMUNICATION RECEIVER

4 Bands, 550 kc/s-30 Mc/s. "S" Meter-BFO-ANL-Bandspread Tuning-Built-in speaker 200/250v. A.C. Brand New. 18½ Gns. Carr. 10/-.

**LAFAYETTE HE-30 RECEIVERS**  
9 valves. 550 kc/s-30 Mc/s. Semi Kit Form. 25 Gns. Carr. Paid.



PART EXCHANGE WELCOME



### MODEL DA-1 AUTOMATIC ELECTRONIC KEYS

Fully transistorised. 230v. A.C. or 6 or 12 volt D.C. operation. £16/10/0. Carr. 4/6. Semi-Automatic Bug keys, £4/10/0. P. & P. 2/6.

### RCA AR.88 RECEIVERS

L.F. Model 75-550 kc/s and 1.5-30.5 Mc/s. Guaranteed Perfect Order. £35. Carr. 30/-.  
D. Model 550 kc/s-32 Mc/s. Guaranteed "As New Condition". £65. Carr. 30/-.



MULLARD OC81-TWO FOR 5/-

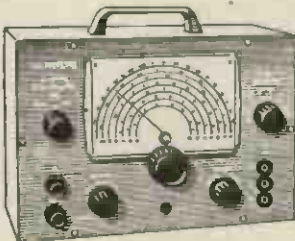

### LAFAYETTE TE-20A R.F. SIGNAL GENERATOR

120 kc/s-390 Mc/s on 6 ranges. Variable R.F. and A.F. outputs. Large clear scale. Size 7¼" x 10½" x 4¼". 220/250v. A.C. Operation. Brand New £12/19/6. Carr. 5/-.



### LAFAYETTE TE-18 GRID DIP METER

Covers 360 kc/s-220 Mc/s. True one hand operation. All coils supplied, operates from 200/250v. A.C. Brand New. Guaranteed. £12/10/-. Carr. 5/-.

**COLLARO STUDIO Tape Transcribers.** 2-track £10.10.0. 4-track £13.10.0. Post Paid.

### CLEAR PLASTIC PANEL METERS

First grade quality. Moving Coil panel meters, available ex-stock. S.A.E. for illustrated leaflet. Discounts for quantity. Available as follows: Type MR. 38P. 1 21/32in. square fronts.

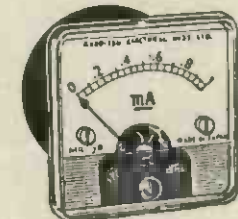

50µA	32/6
100µA	29/6
200µA	27/6
500µA	25/-
50-0-50µA	29/6
100-0-100µA	27/6
500-0-500µA	22/6
1-0-1mA	22/6
1mA	22/6
2mA	22/6

5mA	22/6	1A D.C.	22/6	300V D.C.	22/6
10mA	22/6	2A D.C.	22/6	500V D.C.	22/6
50mA	22/6	5A D.C.	22/6	750V D.C.	22/6
100mA	22/6	3V D.C.	22/6	15V A.C.	22/6
150mA	22/6	10V D.C.	22/6	50V A.C.	22/6
200mA	22/6	20V D.C.	22/6	150V A.C.	22/6
300mA	22/6	50V D.C.	22/6	300V A.C.	22/6
500mA	22/6	100V D.C.	22/6	500V A.C.	22/6
750mA	22/6	150V D.C.	22/6	"S" Meter 1mA	29/6

POST EXTRA Larger sizes available—send for lists.

**ILLUMINATED "S" METER.** 1½ in. square front. Cal. in 8 units. 6V. lamp. 29/6. P. & P. 1/-.  
Ditto 2 5/16in. square 39/6. P. & P. 1/-.

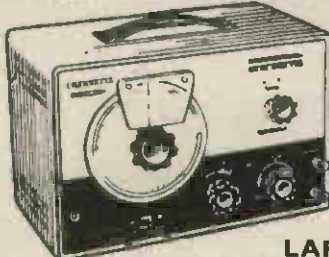

### TE22 SINE SQUARE WAVE AUDIO GENERATORS

Sine: 20 cps to 200 kc/s. on 4 bands. Square: 20 cps to 20 kc/s. Output impedance 5,000 ohms. 200/240v. A.C. operation. Supplied Brand New and Guaranteed with instruction manual and leads. £15. Carr. 7/6.

### LAFAYETTE 'PRECON' AMATEUR PRESELECTOR/CONVERTOR

Converter-20-15-10 metres. Preselector-80-40-20-15-10 metres. Crystal controlled-2 R.F. Stages. 200/250v. A.C. operation. Brand New, 19 Gns. Carr. 7/6.



### LONDON AGENTS FOR CODAR EQUIPMENT

### VOLTAGE STABILIZER TRANSFORMERS

Input 80-120v. and 160-240v. Constant output 110v. or 240v., 250 watts. Brand New Guaranteed. £10.10.0. Carr. 7/6.

### TRANSISTOR 4 CHANNEL MICROPHONE MIXER 49/6

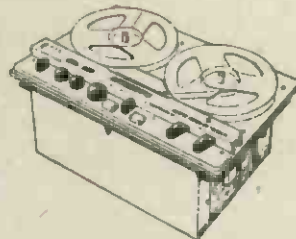

### RK140 STEREO TAPE DECK WITH BUILT-IN PREAMPLIFIER

4 Transistors-4 Valves. Will record or playback ¼ Track Stereo or Mono at 7½ or 3½ IPS. 7" spool size. Twin meter level indicators. 4 inputs. Output 500 MW. 40-18,000 CPS. response. Size 15" x 10" x 6¼". 200/250v. A.C. Operation. Brand New 42 Gns. P. & P. 15/-.

### 9 TRANSISTOR 2 WAY TRANS/RECEIVERS. £25 PER PAIR

RANGE UP TO 5 MILES.

### VARIABLE VOLTAGE TRANSFORMERS

Brand New Guaranteed-Fully Shrouded. Input 230v. 50/60 c/s. Output 0-260 Volts.  
1 Amp-£4.10.0. 10Amp-£18.10.0  
2.5Amp-£5.17.6. 12Amp-£18.15.0  
5 Amp-£9.10.0. 20Amp-£32.10.0  
2.5 Amp Portable-Metal Case with Meter-Fuses, etc. £9/17/6.



### ARMY FIELD TELEPHONES TYPE F

Generator Bell Ringing, 2 Line Connection. With Wood Carrying Case, Fitted Batteries. Supplied Fully Tested. £4/19/6 pair. Carr. 7/6.

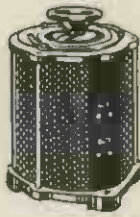

### LAFAYETTE HI-FI STEREO HEADPHONES

16(1)-25-15,000 Cycles. Air Cushioned Headband with cables and overload Junction Box. Brand New Guaranteed. 82/6. P. & P. 2/6.

### TS-76 20,000 O.P.V. PUSH BUTTON MULTI-TESTER

Large clear plastic scale, simple operation. D.C. volts up to 1,000v. A.C. volts up to 1,000v. Resistance up to 10 megohm. Current up to 250 mA. Decibels 20 to + 36 db. Size 6in. x 4¼ in x 2¼ in. Complete with leads, batteries and instructions. Only £5/5/-. P. & P. 2/-.

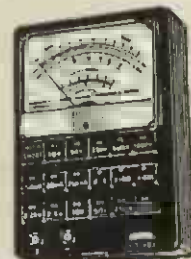

### LAFAYETTE TE-46 RESISTANCE CAPACITY ANALYZER

2 PF-2,000 MFD. 2 ohms-200 Megohms. Also checks impedance, turns ratio, insulation 200/250v. A.C. Brand New £15. Carr. 7/6.

### AMERICAN TAPE

First grade quality American tapes. Brand new and guaranteed. Discounts for quantities.

3in., 200ft. L.P. mylar, 4/-; 3½in., 600ft. T.P. mylar, 10/-; 5in., 600ft. std. plastic, 8/6; 5in., 900ft. L.P. acetate, 10/-; 5in., 1,200ft. D.P. mylar, 15/-; 5½in., 1,200ft. L.P. acetate, 12/6; 5½in., 1,800ft. D.P. mylar, 22/6; 7in., 1,200ft. std. mylar, 12/6; 7in., 1,800ft. L.P. acetate, 15/-; 7in., 1,800ft. L.P. mylar, 20/-; 7in., 2,400ft. D.P. mylar, 25/-.  
Postage 2/-. Over £3 post paid.

### RECORDING HEADS

Reuter: ¼ track Set of 2.....19/6  
Miniflux: ¼ track. Set of 3.....29/6  
Bradmatic: ¼ track. Set of 2.....99/6  
Post Extra.

### HEADSETS

DLR5 Low Imp. .... 10/6  
WS88 Low Imp. with rubber ear pads 17/6  
Chamols padded Moving Coil with Jack Plug, 22/6. Ditto with Mic, 25/-.  
ALL NEW - POST EXTRA



### MULTI-METERS

Brand New-Fully Guaranteed-Lowest ever prices  
Supplied with leads, batteries, instructions

**MODEL PT-34.** 1,000 O.P.V. 0/10/50/250/500/1,000 v. A.C. and D.C. 0/1/100/500 MA. D.C. 0/100kΩ. 39/6. P. & P. 1/6.

**MODEL 500.** 30,000 o.p.v. 0/5/1/2.5/10/25/100/250/500/1,000V D.C. 0/2.5/10/25/100/250/500/1,000V. A.C. 0/50µA/5/50/500mA 12 amp. D.C. 0/60K/6 Meg/60 MegΩ. £8/17/6 Post Paid.

**MODEL NH-400** 10,000 O.P.V. 0/3/3/30/120/300/600/1,200 v. D.C. 0/12/60/120/300/1,200 v. A.C. 0/120µA/30/300 MA. D.C. 0/2K/200K/2 Meg.Ω. 100 PF.-3 MFD. 79/6. P. & P. 2/6.

**MODEL AR-820** 20,000 O.P.V. 0/10/50/250/500/1,000 v. A.C. and D.C. 0/500µA/10/250 MA. 0/10K/100K/1 Meg.Ω. 250 PF-.02 MFD. 0.500 Henrys 92/6. P. & P. 2/6.

**MODEL NH-201** 30,000 O.P.V. 0/25/1/10/50/250/500/1,000 v. D.C. 0/10/50/250/500 v. A.C. 0/50µA/10/250 MA. 0/5K/500K/5 MegΩ. 99/6. P. & P. 2/6.

**MODEL ITI-2.** 20,000 O.P.V. 0/5/25/250/500/2,500 v. D.C. 0/10/50/500/1,000 V. A.C. 0/50µA/25/250 mA. D.C. 0/60K/6 Meg.Ω. .01-3 MFD. 82/6. P. & P. 2/6.

**MODEL TE-12** 20,000 O.P.V. 0/06/6/30/120/600/1,200/3,000/6,000 v. D.C. 0/8/30/120/600/1,200 v. A.C. 0/60µA/6/60/600 MA. 0/6K/600K/6 Meg/60 Meg.Ω. P.F.-2 MFD. 25/19/6. P. & P. 2/6.

**MODEL 250J.** 2,000 O.P.V. 0/10/50/500/2,500 V.D.C. 0/10/50/500/2,500 V.A.C. 0/250 MegΩ. 0/250 mA. - 20 to + 36 db. 49/6. P.P. 2/6.

### SILICON RECTIFIERS

250 v. P.I.V. 750mA	3/-
400 v. P.I.V. 3 amp.	7/6
200 v. P.I.V. 6 amp.	5/6
1,000 v. P.I.V. 650 mA	7/6
800 v. P.I.V. 500mA	5/6
400 v. P.I.V. 500mA	3/6
200 v. P.I.V. 200 mA	3/-
95 v. P.I.V. 3 amp.	5/6
70 v. P.I.V. 1 amp.	3/6
150 v. P.I.V. 165mA	1/-

Discounts for quantities. Post extra.

### MARCONI TF 144 G/4 STD. SIGNAL GENERATORS

85 kc/s-25 Mc/s. Perfect order. £25 Carr. 30/-.

### MINE DETECTOR No. 4A

Will detect all types of metals. Fully portable. Complete with instructions. 39/6. Carr. 10/-. Battery 8/6 extra.

### BEST BUY!

Send 1/- P.O. for full Catalogue and Lists. Open 9 a.m. to 6 p.m. every day Monday to Saturday. Trade supplied.

# GW. SMITH & CO

## (RADIO) LIMITED

Phone: GERRARD 8204/9155  
Cables: SMITHEX LESQUARE

3-34 LISLE STREET, LONDON, W.C.2

# Practical Electronics Classified Advertisements

The pre-paid rate for classified advertisements is 1/- per word (minimum order 12/-), box number 1/6 extra. Semi-displayed setting £3.5.0 per single column inch. All cheques, postal orders, etc., to be made payable to PRACTICAL ELECTRONICS and crossed "Lloyds Bank Ltd." Treasury notes should always be sent *registered post*. Advertisements, together with remittance, should be sent to the Advertisement Manager, PRACTICAL ELECTRONICS, George Newnes Ltd., Tower House, Southampton Street, London, WC2, for insertion in the next available issue.

## SERVICE SHEETS

**SERVICE SHEETS** for all makes of Radio and TV 1925-1964. Prices from 1/- with free fault-finding guide. S.A.E. inquiries. Catalogue of 6,000 models, 1/6, Valves, modern and obsolete. Radio/TV Books. S.A.E. lists. HAMILTON RADIO, Western Road, St. Leonards, Sussex.

**GENUINE SERVICE SHEETS**, Radio/TV/TV Recorders. S.A.E. with enquiries: RED-WATT ELECTRICAL, 41 Denmark Street, Wakefield, Yorks.

**SERVICE SHEETS**, Radio, TV, etc.: List 1/-. S.A.E. Enquiries: TELRAY, Maudland Bank, Preston.

**STATE MODEL NO.** Radio 2/-. TV 2/6. S.A.E. DARWIN, 19 George Street, St. Helens, Lancs.

## SERVICE SHEETS

4/- each, plus postage.

We have the largest display of Service Sheets for all makes and types of Radios, Televisions, Tape Recorders, etc. in the country. Speedy Service.

To obtain the Service Sheet you require, please complete the attached coupon:

From:

Name: .....

Address: .....

.....

.....

.....

To: S.P. DISTRIBUTORS

44 Old Bond St., London, W.1

Please supply Service Sheets for the following:

Make: .....

Model No.: ..... Radio/TV

Make: .....

Model No.: ..... Radio/TV

Make: .....

Model No.: .....

New 1965 List now available.

I also require list of Service Sheets at 1/6.

(please delete items not applicable)

I enclose remittance of .....

MAIL ORDERS ONLY ApPE

## EDUCATIONAL

**HOME STUDY COURSES** in Practical Electronics. Free Brochure without obligation from: BRITISH NATIONAL RADIO SCHOOL, Reading, Berks.

**STUDY RADIO, TELEVISION AND ELECTRONICS** with the world's largest home study organisation. I.E.R.E., City & Guilds, R.T.E.B., etc. Also Practical Courses with equipment. All books supplied. Write for FREE Prospectus stating subject to I.C.S. (Dept. 577), Intertext House, Parkgate Road, London, S.W.11.

**THE INCORPORATED PRACTITIONERS** in Radio & Electronics (I.P.R.E.) Ltd., Membership Conditions booklet 1/-. Sample copy of I.P.R.E. Official Journal 2/-. post free. Secretary, Dept F, 32 Kidmore Road, Caversham, Reading, Berks.

## TRAINING

Full-time courses in RADAR and RADIO-TELEGRAPHY for prospective marine Radio Officers. Govt. approved exam. centre.

Also courses in basic ELECTRONICS, RADIO, TELEVISION and PRACTICAL SERVICING.

Apply:—Director, British School of Telegraphy, 20 Pennywern Road, Earls Court, London, S.W.5

**A.M.I.E.R.E., B.Sc.(ENG.), A.M.I.Mech.E., City & Guilds, G.C.E., etc.**, on "NO PASS—NO FEE" terms. Wide range of guaranteed Home Study Courses in Electronics, Computers, Radio, T.V., etc., 156-page Guide—FREE. Please state subject of interest. BRITISH INSTITUTE OF ENGINEERING TECHNOLOGY, 151 College House, Wright's Lane, London, W.8.

## MISCELLANEOUS

**CONVERT ANY TV SET** into an Oscilloscope. Diagrams and Instructions, 12/6. REDMOND, 42 Dean Close, Portslade, Sussex.

**HAMMER FINISH PAINT.** The modern finish for electronics. Can be brushed or sprayed. Blue or silver, 2½oz tins 3/6, ½ pint 7/6, 1 pint 15/-. Post 6d. on any order. Trade supplied. FINNIGAN SPECIALITY PAINTS, (PE), Mickley Square, Stocksfield, Northumberland.

**TELEVISION SETS**, not working. For callers only. 17in. £1/10/-; 21in. £3/10/-; 14in. mains portables £2/10/-. Phone: Bournemouth 26849.

**GOVERNMENT SURPLUS** Electrical and Radio Equipment. Our new illustrated catalogue No. 16 ready early March. 2/6 POST FREE, cost refunded on purchase of goods over £2. ARTHUR SALLIS RADIO CONTROL LTD., 93 North Road, Brighton, Sussex.

## TAPE RECORDERS, TAPES, ETC.

**FOR QUALITY** consult our sixty-page (photographically illustrated) latest Hi-Fi equipment catalogue (4/6d.). Unbiased advice, preferential terms to members, LP-s from your precious tapes. AUDIO SUPPLY, 10 Clifford Street, London W.1.

**BRITAIN'S LARGEST TAPE EXCHANGE** welcomes you: "WORLDWIDE TAPE-TALK," 35 The Gardens, Harrow. S.A.E. for particulars.

**TAPE TO DISC RECORDING.** 10in LP, 42/-; 12in LP, 48/-; 7in EP, 21/-. S.A.E., Leaflet, DERBY SOUND SERVICE, 52 Hest Bank Lane, Hest Bank, Lancaster. Tel.: HB.2444.

## SITUATIONS VACANT

### RADIO TECHNICIAN

A number of suitably qualified candidates will be required for training, leading to permanent and pensionable employment. (Normally at Cheltenham but with opportunities for service abroad or appointment to other U.K. stations).

**Applicants** must be 19 or over and be familiar with the use of Test Gear and have had Radio/Electronic workshop experience. They must offer at least "O" level GCE passes in English Language, Maths and/or Physics, or hold the City and Guilds Telecommunications Technician Intermediate Certificate or equivalent technical qualifications.

**Pay** according to age, e.g. at 19 £722, at 25 £929 (highest pay on entry) rising by four increments to £1,067.

**Prospects** of promotion to grades in salary range £997—£1,634.

**Annual Leave** allowance of 3 weeks 3 days, rising to 4 weeks 2 days.

Normal Civil Service sick leave regulations apply.

Apply

Recruitment Officer (RT/54)

Government Communication Headquarters

Oakley

Priors Road

Cheltenham

# Practical Electronics Classified Advertisements

CONTINUED

## TRANSFORMERS

### TELEVISION:!

From your OWN Car Battery

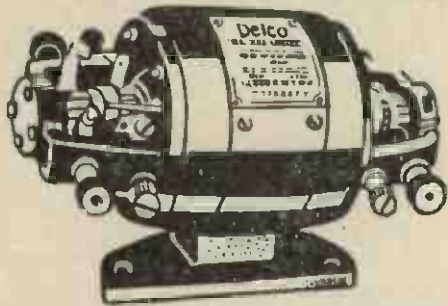

Famous DELCO TRANSFORMER transforms 12 or 24v. supply to mains Power for TV, 1/4" drills, etc. NOW ONLY 65/- C.O.D. 2/6 extra. Carr. Paid.

VIBRATOR POWER-PAK. Step 12v. up to MAINS output. For Universal AC/DC razors, small fluorescent fittings, 32/6 radios, etc. Only

HOOVER ROTARY TRANSFORMERS. 6v. input, 250v. output. 12v. input, 490v. output. 32 watts. Brand New GENERATING SETS. Brand New. TINY TIM. 12v. 300 watts. In packing case. SELF STARTING. Normal List Price £76. Price Delivered £35

Send NOW—Delivery by return

JAMES WALKER, ELECTRONICS DIVISION

36 Alexandra Street, Thurmaston, Leicester

## FOR SALE

**DID YOU KNOW** that Suffolk Tubes, still the largest independent tube rebuilders, give a free delivery service by van or passenger train to all parts of the U.K. Each tube is guaranteed 12 months and all types are always available off the shelf at keenest prices. 1-3 Upper Richmond Road, Putney, London, S.W.15. Telephone Vandyke 4304/5267.

**NEW £18 DYNAMOTORS.** Input 12/18 volts. Output 240 V, 120/200 watts, AC/DC, bargain £4. J. O'BRIEN, 1, Hightown, Waterfoot, Rossendale, Lancashire.

**TRANSISTORS UNMARKED UNTESTED.** 40 for 10/-, P. & P. 1/-. 4 packets post free. Relays, thousands of types, special catalogue free. General Catalogue of Mechanical & Electrical Gear, Tools, etc., 5,000 items, free. K. R. WHISTON (Dept. PET), New Mills, Stockport.

**RELAYS, EX-GOVERNMENT.** £3 for 12, our selection, post paid. WALTONS WIRELESS STORES, 15 Church Street, Wolverhampton.

## ELECTRIC SOLDERING IRON



### FANTASTIC BARGAIN OFFER

ONLY 9/6

Lightweight Pistol Grip handle, 40 watt, 240 - 250v. A.C. Solid copper bit, detachable handle forms cover for iron when not in use. With 4ft. Safety 3-core flex. Indispensable for every home handyman. A boon to model makers and a necessity for every electronics enthusiast. Offered to you at this new amazing price.

C. H. SERVICE (Dept. P.E.1)  
Lusted Hall Lane, Tatsfield, Kent.

## FOR SALE

(continued)

**VENNER TIME SWITCHES** reconditioned, 14-day clock, once on, once off every 24 hours, jewelled movement, fully guaranteed, 5 amp., 32/6; 1 amp, 25/-. P. & P. 2/6. A. R. BATCHELOR (P.E. Dept.), 4 Park Road, Bromley, Kent.

**5-TON FACTORY CLEARANCE,** Radio, TV Electrical Components, in mixed parcels. Example: 28lb. mixed parcel £1, pp 7/6d. Speakers, grilles, valves, bases, i.f.s. covers condensers, etc. Hundred other items. S.A.E. List and Postal Orders to P. NEWTON, 16 Shalcross Crescent, Hatfield, Herts.

**CONDENSER BARGAIN!** Miniature paper condensers, 1/2in x 1/2in. Ideal for transistor sets, .0001, .001, .002, .005, .02, .04µf. Your choice, 7/6d. per 100 or £3 per 1,000. G. F. MILWARD, 17 Peel Close, Drayton Bassett, Staffs.

## WANTED

### NEW VALVES WANTED

Any type, or quantity

CASH PAID

R.S.T. Valve Mail Order Co.

211A Streatham Road

Mitcham, Surrey

Telephone: MITCHAM 6202

## RECEIVERS AND COMPONENTS

**A.1 POST FREE BARGAINS.** Guaranteed reclaimed valves. Send for full list to Dept. MO/E, A.1 RADIO COMPONENTS, 14 The Borough, Canterbury, Kent.

**TWO "P.E." 5W. AMPS C/W POWER UNIT,** £10; Heathkit SSU-1 £5. 136A, Orchard Way, Shirley, Surrey.

## R. & R. RADIO & TV SERVICE

44 Market Street, BACUP. Tel. 465

### SALVAGE VALVES

6F13 4/6 10P14 5/- PL82 3/6 20P4 6/6  
6L18 4/6 20P5 6/6 U801 7/6 30P16 5/-  
EF80 1/6 30P4 7/- 10F1 1/6 PCC84 4/-  
ECC82 6F15 5/- 20F2 5/6 PCL83 5/-

ECL80 3/- EB91 1/- 30FL1 5/- PY81 3/6  
30F5 5/- EF85 5/- PY32 6/- U301 6/-  
PL38 6/- EF37 6/- 6U4GT 10P13 5/6

PCF80 20P3 6/- 6F1 1/6 20D1 1/6  
PL81 5/- 30PL1 6/- ECC81 3/- 30P12 6/-  
PZ30 5/- PL36 6/- EY86 4/- PY82 4/-  
U329 5/- PCL82 5/-

Post 6d. per valve, 3 or more post free. Speakers ex T.V. 5 inch round 3/6, 6 by 4 inch 3/6, 8 inch round 6/-, post 2/-.

Printed circuit panels, 7 1/2" x 3" clean condition containing 3 9BA v/h, Diode, resistors and condensers 3/-, post paid.

10" speakers, cast alloy chassis, ex equipment, 3 ohm 12/6 including post.

Resistors, New: 1/2 watt 3/4d., 1 watt 5d., 2 watt 9d., all 10%. Silver mica, paper and electrolytics in stock. New Mullard transistors and condensers also in stock. S.A.E. with all enquiries. All goods subject to satisfaction or money refunded.

## RECEIVERS AND COMPONENTS

(continued)

**TRANSISTORS.** OC44, OC45(M), OC81(M), OC81D(M) 5/-. AF117 7/6. Set of 3 OC81/81D 12/6. OA81 Diodes 2/9. Miniature Condensers. 8, 16, 25, 50, 100 mFd. 15 volts 2/3. B.E. CURREN, 77 Lydiate Lane, Ecclestone, Chorley, Lancs.

**"P.E." V.H.F. BROADCAST RECEIVER.** S.a.e. for itemised price list including ready wound coils. Mullard Capacitors for the companion Integrated Transistor Amplifier also available. AJAX ELECTRONICS, 18a Rumbold Road, Fulham, London, S.W.6.

### 100% TRANSISTORS

OC44, 45, 81, 81D, 72. 2/9 EA.  
AF116, 117. 3/6 EA. BY100.  
5/- EA. OC26. 7/6 EA. OA81.  
2/- EA. ORP12. 7/6 EA.

### ROBINSON (RADIO, T/V)

4 Highcliffe Rd., Blackley, Manchester 9  
CHE. 1175

**WE HAVE LARGE STOCKS** of surplus components to dispose of, so we have decided to offer you a mixed parcel of 200 items for 45/- post paid. You won't be disappointed. GEORGE HANNINGTON, 88, Latimer Road, London, W.11.

### SCINTILLATION COUNTER 1093(B)

Using CV2316 Photo tube plus 10 other valves, magnetic counter with lens, each unit in case but made for 19in. rack mounting x 8 1/2in.

### POWER UNIT 1093(B)

for above, mains 200-50 input, output stabilised (1) 0-2 KVolts; (2) 0-300 V at 120 mA both adjustable, meter for checking voltages, same size as above, made by Ferranti. These two units are the complete set, and are checked complete, but as we know very little about this kind of equipment no enquiries can be answered. ONLY £12/10/0, BR8 10/-, or either unit £7/0/0, BR8 7/6. Scaling Units 109(A) & (B) S.A.E.



**BULK PURCHASE OF STABILISED P.U. MADE BY MARCONI or EDISWAN, ALL INPUTS 200-50 AC**

(1) General Purpose P.U. two adjustable independent outputs (11) - 0/250 V at 50 mA; (12) + 0/250 or 0/500 V at 250 mA. Also 6.3 at 9 amps, using 5-GZ32, 3-12E1 and 7 other valves, meter for checking output voltage or current, both voltages adjustable. 19in. rack mounting x 10 1/2in. ONLY £14/10/0. Matching case 20/-, BR8 10/-.

(2) Transistor P.U. MkII Two adjustable independent outputs (1) - 0/10, - 0/100 V; (2) + 0/10, + 0/100 V, metered output and same in looks and size as above power unit, using 20 valves £14/10/0. Matching case 20/-, BR8 10/-.

(3) As above but 0/15 V, 0/150 V.

(4) Three outputs 200-255, 255-350, at 200 mA, 350-400 at 150 mA all adjustable 6.3 C.T. 4 amps twice, 19in. rack mounting x 8 1/2in. £8/10/0. Matching Case 20/-, BR8 10/- (Two meters Voltage and Current.)

(5) Output 120-250 Variable at 50 mA, 6.3 CT 4 amps, using two meters Voltage, Current. 19in. rack mounting x 7in. £5/10/0. Matching case 20/-, BR8 10/-.

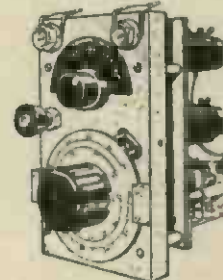

**REJECTOR UNITS 1-2-10 mc/s** in 4 switched ranges. Ideal for harmonic suppression of TX, or as a station retractor for RXs, just plug aerial into one socket and connect to other socket, large tuning knob and dial, in small grey case. BRAND NEW ONLY 35/-, post 5/-.

### J. T. SUPPLY CO.

38 MEADOW LANE, LEEDS 11, YORKS.

CONTINUED OVERLEAF

## RECEIVERS AND COMPONENTS

(continued)

**TRANSISTORS 25 FOR 10/-.** State AF RF Silicone or Switching. 100 Computer Diodes 12/-, mainly unmarked but tested types and data supplied S.A.E. list—LST COMPONENTS, "Dalarna," Villa Road, Benfleet, Essex.

**LIGHT SENSITIVE TRANSISTORS,** with circuits, 5/- each, P.P. 6d. MEADOWS, 10, Hecolylan, Barmouth, Merioneth.

● **BARGAIN CLEARANCE OF RADIO COMPONENT PARCELS AT 15/- EACH INC:** P.P. Each contains: 1 cad-plated chassis (already punched to suit parts in parcel). 1 120m.A mains transformer, 1 twin gang condenser, 1 6:1 ratio slow-motion drive, 1 output transformer, 40 resistors (47 ohm-2.2 meg.  $\frac{1}{2}$ -2 watt). 44 capacitors (50 p.f.-2 m.f.d.). 4 electrolytics. 2 volume controls. 6 valve sockets. 1 spanner. 1 screwdriver. 2 double-tuned i.f. transformers. 1 four-pole, two-bank three-way switch. Various aerial coils and other components inc: plugs, sockets, nuts, bolts, wire, cable, solder and etc. All parts guaranteed new. S.G. Brown headphones (type F). Brand new 12/6 per pair, inc. p.p. **MAIL ONLY. TRANSTEC ELECTRONICS LTD.,** 148 Kingsland High Street, London, E.8.

**PRINTED CIRCUITS.** One off, certainly. Practical Electronics, Practical Wireless, Wireless World, Radio Constructor designs. S.A.E. for details. J.E.S. ELECTRONICS, 32 Pencaig, Llangefni, Anglesey.

**TRANSISTORS!** Give-away price. NKT124/5 Power Type. 6 for 10/-. 2SO17 4W, up to 60 volts, 5/- each. Post free, G. F. MILWARD, 17 Peel Close, Drayton Bassett, Staffs.

## TELEVISION TUBE SHOP

FOR

Unused, Guaranteed Tubes  
OVER 2,000 IN STOCK

At prices from 50% to 75% of  
normal List Price

All tubes tested before despatch  
and Guaranteed for 12 months

CARRIAGE 10/- via B.R.S. or  
15/- via passenger train

TERMS £2 down (plus  
carriage) and balance at £1  
per month

See our advertisement in  
PRACTICAL TELEVISION for exact  
prices, or write for details

## TELEVISION TUBE SHOP

48 BATTERSEA BRIDGE ROAD  
LONDON, S.W.11. BAT 6859  
OPEN ALL WEEK AND SATS. UNTIL 4 p.m.

458

Key Switch, 3 position, centre off, 3 c/o + 4 c/o, 6/-

Ferox Cubes LA12, wound, 5/-

Panel Lamps, Min. Lilliput screw, White Bezel, 3/-

DLR5 Headphones, with plug and socket, 12/6  
Min. Lilliput screw bulbs, 12 volt, 1/6

High Speed Relay, c/o 1,000 + 1,000 ohm, 6/6-  
400 ohm P.O. Relay, 1B, 5/-; 1B 1M, 6/-

2,000 ohm P.O. Relay, 1M, 5/-; 1M 1B, 6/-  
G.P.O. Hand Sets, with Press to Talk in handle, 15/-

G.P.O. Jack Plug, with lead, 3/-

Isolated Jack Socket, 2/6

Breast Set Mike, with fittings, 6/-

500 Micro Amp Meter and Meter Switch, 15/-  
Toggle Switch, SP on/off, 2/6

Push Button Switch, DP on/off, on when press only, 2/6

Power Supply and LF Amplifier, N/O 1, 15/-  
for N/O 38 set

6 core min. Cable, 3 amp screened PVC outer, 3/- yard; 12 core ditto, both fitted with Plessey plugs and sockets, in 10 yard lengths only

New range of High Stability Resistors, 5% to 1%,  $\frac{1}{2}$  to 5 watt, send for full lists.

Telescopic Drawer Slides, 17 $\frac{1}{2}$ in. to 29in., 12/6 pair

Copper Laminate Board, single or double sided, 5/- sq. ft., or 3ft. by 4ft. panels, 33/-

Jones Plugs and Sockets, 4-12-18-24-32 way, 5/- pair

Plessey Plugs and Sockets, 2-4-6-12-25 way, 5/- pair

31 way P.O. Cable, 2/- yard. Minimum 5 yards.

Ever Ready Batteries, 90V + 7 $\frac{1}{2}$ V, 4/6 or 12 for 30/-

Mallory Mercury Cells, 6.75V, 3/6

8 Tag Panels, with 150 Resistors, Condensers, Diodes, 10/-

2ft. 9in. Mobile Aerials, 6/6

30 meg. Oscillator Unit, 3 valve tunable to 27 meg., 12/6

Parcel of ex-Government valves, 20 for 10/-  
Small Component Boxes, 7 divisions, 60 for 12/6

Printed Circuit Preset Pots, 10K, 2/-

115 volt Western Electric Magslips, 50/- each

230 volt BTH Magslips, 90/- each

Electro Magnetic Counters, P.O. 4 digit, 4/6

Mu Metal Screen for 5UP7 tubes, 6/6

30 + 30 pF Variable Condensers, 4/-

$\frac{1}{2}$  amp Fuses, 5/- per 100, 1 $\frac{1}{2}$ in. x  $\frac{1}{2}$ in.

Mic. Jacks, 3 for 3/-

Small Instrument Cases, 5in. x 5in. front, 4 $\frac{1}{2}$ in. deep, with grey plastic front, 6/- each. Rack to house two of these, side by side, 7/6

Transformer PL1101, output 7 volt at 4 amp, three times plus 7 volt at 125 mA, 18/-

H.T. Transformers, 1,800 volt plus 1,800 volt at 500 mA, and 600 volt plus 600 volt at 500 mA, 60/-

8 way min. cable 10 yds, 10/-

## E. R. NICHOLLS

Mail Order and Retail Shop:

46 LOWFIELD ROAD

off

SHAW HEATH

STOCKPORT, CHESHIRE

## RECEIVERS AND COMPONENTS

(continued)

### TESTED TRANSISTORS

All new, few equivalent.

1/- each, Red or White Spots.

2/- each, XA101, XA102, XB103, OA90, OC430, XA112, XA111.

3/- each, OC44, OC45, OC70, OC71, OC81, OC81D, OC200, GET16.

4/- each, AF114, AF115, AF117, OC170, OC171, SX658, XU611.

5/- each, OC72, OC139, OC140, OC204, ORP60, BY100, GET8.

10/- each, OC35, OC26, OC28, GET57, 2SO13. All new, few equivalent.

ZENER DIODES 4.7 v. to 33 volt  $\frac{1}{4}$  watt, 3/6 each. 1.5 watt, 5/- each, 7 watt, 6/- each.

Send 3d. stamp for Full Price List and Free Equivalent Chart.

## B. W. CURSONS

78 BROAD STREET

CANTERBURY, KENT

### FAMOUS TRANS/RECEIVER

Covers 2-4.5, 4.5 - 8 Mc/s. (150-37 metres) in two bands. 230/250v. A.C. Mains. Six valve superhet receiver with I.F.'s of 465 Kc/s, and six valve transmitter designed for voice and C.W. Incorporates test & tuning 500  $\mu$ A meter for voltages, aerial loading and current tests.



Panel controls Freq. PA. Tuning Gain MCW, CW, RT, Het Tone, Netting, On/Off Quench, Aerial, AVC, LT-HT Tests. Supplied complete. Fully tested and working. Price £12.10.0. Carr. £1.0.0.

**RCA AR88D. RECEIVER (Brand New)**  
Freq. 540 Kc/s—32Mc/s, 6 waveband, Mechanical Band spread with Logging scale, Auto and Man. Vol. control, ditto Noise Limiter, BFO, Pitch and Var. HF Tone controls, RF & AF Gain, Var. selectivity with Crystal Filter. Complete with Instructions/Service Manual, Spare Valves, H/Set, Aerial, etc. £75. USED MODEL Fully tested and working £45. Carr. £2 on each.

**TELESCOPIC AERIAL MASTS.** Tubular steel copperised, spray finish, ring cam locking on each section provides for full or any height required. Suitable all fixings and base locations. Bottom section 1 $\frac{1}{2}$ in. diameter. 20ft. (4 section) Closed 5ft. 9in. Weight 16lb. 55/-. Carr. 5/-. 34ft. (6 section) Closed 6ft. 6in. Weight 20lb. 75/-. Carr. 5/-. Further height by adding 3-4 Whipsections, 13/6. Carr. 1/6. Special price for quantities.

**CREED TELEPRINTERS.** 7B Used condition, £12/10/-. Carr. 30/-.

**WAVEMETER CLASS D.** Freq. band 1,900 Kc/s to 8,000 Kc/s. (158-37.5 metres) in two ranges, 1,900 Kc/s, 4,000 Kc/s, also 4,000 Kc/s, 8,000 Kc/s Supply 6v. D.C. Input. Complete with twin crystal. As new. Price 57/6. P. & P. 5/-.

Many other bargains. S.A.E. all enquiries.

A. J. THOMPSON,

"Eiling Lodge" Codicote, Hitchin, Herts.  
Phone: Codicote 242

**RECEIVERS AND COMPONENTS**  
(continued)

**TRANSISTORISED SIGNAL INJECTOR.** Complete kit of components and circuit of injector for testing and amplifier or radio, 7/6 only. Post free. G. F. MILWARD, 17 Peel Close, Drayton Bassett, Staffs.

**METAL WORK**

**CABINETS • CASES  
CHASSIS**

Anything in metal. "One-offs" a pleasure  
Send your drawing for quote  
Stove enamelled in any professional finish  
**MOSS, WATSON**  
40 Mount Pleasant Street, Oldham  
Lancs. MAIN 9400

**DIGITAL COMPUTER**

A simple digital Adder/Subtractor using switches and lamps only. A fascinating demonstration of binary arithmetic. Full circuit, wiring diagram, and notes on the Binary system, 3/6d. post free.

**NOUGHTS and CROSSES MACHINE**

New simple Mark 2 model, using switches and lamps only. This machine cannot be beaten. Full circuit, wiring diagram, and instructions, 3/6d. post free.

**FOOTBALL POOL COMPUTER**

Novel low cost circuit for forecasting.

**ANALOGUE COMPUTER**

Simple demonstration of multiplication and division by electrical analogue. Football Pool and Analogue circuits, wiring diagrams, instructions, 3/6d. post free the two.

Multimeters Illustrated leaflet on request. EP10K, 10,000 o.p.v., 67/6, post 1/6; EP30K, 30,000 o.p.v., 105/6, post 2/3; EP50K, 50,000 o.p.v., 145/6, post 2/6.

**PLANET INSTRUMENT CO.**  
25 (E), DOMINION AVE., LEEDS 7

**CLEARANCE SALE**

MAKE

**5**

**DIFFERENT  
TRANSISTOR RADIOS**

for **35/-**



Amazing Radio Construction Set! Become a radio expert for 35/-. A complete Home Radio Course. No experience needed. Parts include instructions for each design, Step-by-Step plan, all Transistors, loudspeaker, personal phone, knobs, screws, etc., all you need. Box size 14" x 10" x 2" (parts avail. sep.). Originally £6. NOW 35/- + 3/- P. & P. (3/- C.O.D.)

**ASTONISHING  
CIGARETTE  
RADIO 18/6  
only**

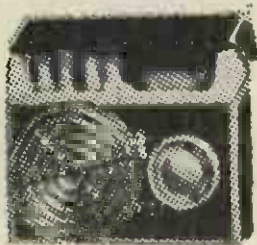

Yes, a perfectly ordinary packet of cigarettes!—but watch your friends astonishment on hearing it fetch in station after station, loud and clear! Still holds 10 Cigarettes—yet cleverly conceals highly sensitive, fully transistorised circuit (including tiny battery). Even a young boy can assemble it in under 2 hours. No soldering. No experience necessary. Only 16 connections to make. Ideal for taking to work with you. From our bulging testimonial file, Mr. D.B. of Huddersfield writes:—"... I have fitted the parts in and it is working wonderfully..." ALL PARTS including Semi-Conductors, A.B.C. Plans, etc. ONLY 18/6d. plus 1/6d. post, etc. (C.O.D. 1/6d. ex.)

**CONCORD ELECTRONICS LTD**

(DEPT. P.E.16) 9 Western Road, Hove

**PADGETTS RADIO STORES**

Dept. P.E., OLD TOWN HALL, LIVERSEDGE, YORKS.

Telephone: Cleckheaton 2866

USA Bomb Computers in original transit case, full of gears, motors, vidor counter, gyro, etc., 37/6, carriage 10/6.

PCR, 12 volt Vibrator pack, in original packing case, 25/6, carriage 8/6.

RAF Sighting Heads. Complete with lamp, lens, etc. No details. Packed in original metal case, 15/6, carriage 10/6.

Single Phase 240 volt, 1,400 r.p.m., 1/2 h.p. motor with pulley, 26/6, less pulley, 24/6, fully guaranteed, ex washing machine. Carriage 8/6.

One Sixth H.P. Motor, 240 volts 15/6, post 6/9.

New Indicator Unit. CRT 100, complete with two tubes, type VCRX393 and VCRX298, plus 21 small valves, relays removed, 57/6, or less valves 32/6, carriage 10/6. Sorry no details on the unit.

New 12in. Speakers with built-in tweeter. 3 or 15 ohms, 28/6, post paid.

P.M. Speakers, all 3 ohms, ex TV sets. 6in. round 6 x 4in. and 5in., 3/6, post 2/6, 6 for 20/6, post paid. 8in. round, 6/6, post 2/6 7 x 4in., 5/6, post 2/6.

**VALVE LIST**

Ex equipment. 3 months guarantee.

EL91	1/8	U801	8/8	PCL82	5/-
ECL80	2/-	U281	5/-	PCL84	5/-
ECC82	3/-	U282	5/-	PL36	5/-
EY51	2/6	U329	5/-	V25	5/-
EY86	5/-	KT36	5/-	VR150/30	3/-
EBF80	4/8	5U4	4/-	IT4	1/9
EB91	9d.	6V6GT	4/-	12AT7	3/-
EL38	5/-	6X5	4/-	6CH6	1/8
EF91	9d.	6K25	5/-	6X4	3/-
6F1	1/-	6P25	3/8	6X4	3/-
6F14	5/-	6U4	5/-	ARP12	1/8
6F15	5/-	PY33	6/-	807	5/-
10C2	5/-	PY80	3/-	EF50	1/-
10F1	1/-	PY81	3/-		Doz. 8/-
10P13	5/-	PL81	4/-	6K7	1/3
10P14	5/-	PL82	3/-		Doz. 10/-
20D1	2/-	PL83	3/-	6V6	1/9
20L1	5/-	PL33	3/-		Doz. 18/-
20P3	4/-	PY82	3/-	6K8	1/9
20P1	4/-	PGF80	4/-		Doz. 18/-
20P4	8/8	PCC84	4/-		

Breaking up Mark III Type 19 Sets. Pointer Knobs 7/- doz., post paid. Jack Socket, 1/-, post 6d., doz. 10/-, post paid. Jack 1/8, post 6d. Toggle Switch, metal, 6d., post 6d., doz. 7/8, post paid. Relay type 3000, 1/9, post 1/9, doz. 20/-, post paid. Any other spare send 2/- plus post to cover.

Reclaimed Tubes. 6 months guarantee, 14in. Mullard and Mazda, 17/6, carriage 10/6. 17in., 30/-, carriage 10/6.

**PRINTED  
CIRCUIT  
BOARDS**

Available for GULTON ultrasonics remote control system. Mullard 10 Watts Transistor Amplifier. Write for details to:

**TATES ELECTRONIC SERVICES LTD.**  
3 WATERLOO ROAD, STOCKPORT, CHESHIRE

**AN EXTRA ROOM IN  
YOUR LOFT**



Make your loft usable. Fit a Benson disappearing loft ladder. Rigidly constructed. Folds out of sight. Closes trap automatically.

Write now for illustrated brochure, floor strengthening details and terms—all post free.

ONLY **£12-19-6** carr. paid

Credit Facilities

Handrails 25/- each extra  
ALL TYPES OF LADDERS SOLD

**BENSON'S**

(Dept. P.E.)  
Pontefract Avenue  
Pontefract Lane  
York Road, Leeds 9  
Tel. 34918 (2 lines)

**DUKE & CO. (LONDON) LTD.**

621/3 Romford Road, Manor Park, E.12  
ILFord 6001-2-3 Stamp for list

**T.V. TUBES**

17in. — 35/- 14in. — 15/-

Most makes and types available. Set Tested. Guaranteed good picture. Ex Rental Service Depts. Stock. Carriage 5/- extra  
NEONS 25 box 2/- (S.B.C.D.P. fittings). Mains tester and visual reminders. P. & P. 1/-.

**TAKES HEADACHES OUT OF  
ALL SERVICING PROBLEMS**

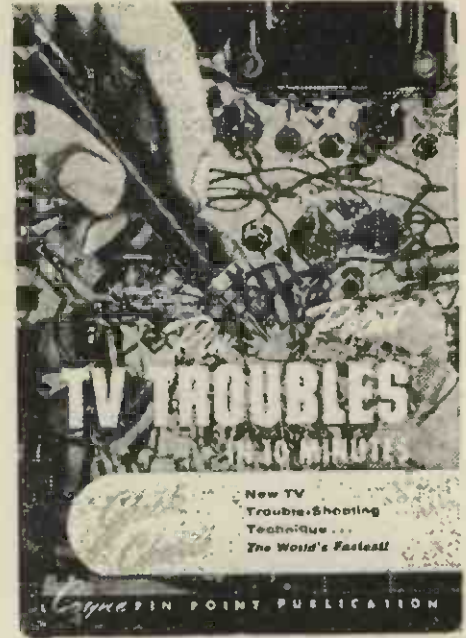

Your most useful on-the-job "tool"! Quickly and easily pin-points the exact trouble in any TV set. Covers 70 symptoms, 700 trouble spots. Over 340 cross-indexed pages; 50 time-saving Check Charts; 290 diagrams and photos; explanation of circuits and designs.

**SIMPLE CHECK-CHART SYSTEM  
SAVES TIME!**

This amazingly practical handbook shows you how to find the trouble in any TV circuit FAST! Simple cross-index tells you in what section you'll find cause of trouble. Handy Check-Charts then help you accurately locate the EXACT trouble spot. Cut waste time, eliminate hours of aggravation, get right to the heart of the trouble in minutes.

**USE THIS BOOK RIGHT ON THE JOB—  
NO NEED TO MEMORIZE!**

This Pin-Point Book was designed especially for on-the-job trouble-shooting. You simply turn to the indexed section, locate the circuit description and Check-Chart, and in minutes you have the trouble spot located and ready for repair. No complicated theory or mathematics. Down-to-earth, practical circuit description, service methods and trouble-shooting techniques. Published by the famous Coyne Electrical School and approved by leading authorities in the field. Don't miss out any longer. Time wasted now locating T.V. faults could be saved by quick reference to this lightning fast T.V. problem answer book. Send for your trial copy now, then when you decide to keep it (as we are sure you will), pay only 5/- per week until completed.

The price? Only 39/6 plus postage 1/6.

**FREE ELECTRONIC DATA HAND-  
BOOK WITH EVERY ORDER**

**IRONCLAD GUARANTEE**

This book must be able to earn you more than its cost within two weeks or your money refunded! Free 88 page oscilloscope book will be included if you send cash with order.

**FREE TRIAL OFFER!**

TERMS ONLY 5/- PER WEEK

To **SIM-TECH TECHNICAL BOOKS**  
Dept. ETV6  
West End, Southampton, Hants.

Please send "T.V. Troubles" for a full seven days' free trial. If not delighted I may return the manual, post paid without further obligation on my part. Otherwise I will pay cash of 5/- weekly until paid.

Tick here if enclosing full price of 41/- (which includes 1/6 postage). You get free Oscilloscope Book. Same 7-day money back guarantee. Overseas customers please send full amount (including Ireland).

Name .....

Address .....

City ..... County .....

**TYGAN FRET** (Contem. pat.), 12 x 12in. 2/-; 12 x 18in. 3/-; 12 x 24in. 4/-, etc.  
**EXPANDED ANODISED METAL**—Attractive gilt finish 1/2 in. x 1/2 in. diamond mesh 4/8 sq. ft. Multiples of 6 in. cut. Max. size 4ft. x 3ft., 47/8, plus carr.  
**BONDACOUST Speaker Cabinet** Acoustic Wadding (1in. thick approx.) 12in. wide, any length cut, 1/8 ft., 4/- yd.

**Volume Controls**—5K-2 Meg. ohms, 3in. Spindles. Morganite Midget Type 14in. diam. Quar. 1 year. LOG or LIN ratios less Sw. 3/- DP. Sw. 4/8. Twin Stereo less Sw. 8/8. DP. Sw. 8/- Specials to order.

**WAVECHANGE SWITCHES.** 1 p. 12-way, 2 p. 2-way, 2 p. 6-way, 3 p. 4-way, 4 p. 2-way, 4 p. 3-way, long spindle, 3/8 ea.

**ENAMELLED COPPER WIRE**—1lb. reels 14g-20g, 2/8; 22g-28g, 3/-; 30g-34g, 3/9; 36g-38g, 4/3; 39g-40g, 4/6, etc.  
**TINNED COPPER WIRE.** 16-22g, 2/8 1/2 lb.  
**ERSIN MULTICORE SOLDER.** 60/40 4d. per yard. Cartons 2/8, etc.

**New Boxed VALVES Reduced Bargain Prices**

1T4	3/8	EF86	8/8	PCL83	10/8
1R5, 185	6/-	EL33	12/8	PCL84	10/-
384, 3V4	7/-	EL34	12/8	PCL85	11/8
ECC81	7/-	EL84	7/-	PL36	10/8
ECC82		EY81	9/-	PL81	9/8
ECC83	9/-	EY86	9/-	PL83	8/-
ECL80		EZ81	7/-	PY33	10/8
ECL82	10/-	GZ32	8/8	PY82	7/-
ECL86	10/8	PCC884	8/-	U26	10/8
EF80	7/8	PCF80	8/-	UL84	9/-

**CO-AX 80 ohm CABLE**

High grade low loss Cellular Air Spaced Polythene—1/2in. diam. Stranded Cond.

Now only 6d. yard

**BARGAIN PRICES—SPECIAL LENGTHS**  
 20 yds. 9/-; P. & P. 1/8. Coax. Plugs 1/-;  
 40 yds. 17/8; P. & P. 2/-. Sockets 1/-; 60 yds.  
 25/-; P. & P. 3/-. Couplers 1/3.

**DE-LUXE RECORD PLAYER KIT**

Incorporating 4 Sp. Garrard Auto-Slim unit and Mullard latest 3 watt printed circuit amplifier (ECL86 and EZ80), vol., bass and treble controls, with 8 x 5in. 10,000 line speaker. Contemporary styled two-tone cabinet, charcoal grey and off-white with matching blue relief. Size 17 1/2 in. x 16in. x 8in. A stylish unit capable of quality reproduction. Circuit and const. details 2/6 (free with kit).



**COMPLETE KIT**  
 Carr. and ins. 10/- **£13.19.6**

Illuminated Perspex control panel escutcheon 7/6 extra. Ready wired 30/- extra. 4 contemporary mounting legs (6 or 13in.), 12/6 per set.

**RECORDING TAPE**

Famous American Columbia (CBS) Premier quality tape at NEW REDUCED PRICES. A genuine recommended Quality Tape—TRY IT. Brand new, boxed and fully guaranteed. Fitted with leader and stop folls.

	Standard	Double Play	Long Play	
5" 600'	13/-	1,200'	31/8 900'	17/8
5 1/2" 900'	16/-	1,800'	37/8 1,200'	19/8
7" 1,200'	21/-	2,400'	47/8 1,800'	28/8

Post & Package per reel, 1/- plus 6d. each for additional reels.

**SPECIAL OFFER 3" Message**  
 tape 150', 3/9; 3" L.P. 225',  
 4/9; 3" D.P. 300', 8/6. P. &  
 P. per reel 6d.

**TAPE REELS** Mftra. surplus  
 7", 2/3; 5 1/2", 2/-; 5", 2/-; 3",  
 1/3; Plastics spool containers,  
 5", 1/8; 5 1/2", 2/-; 7", 2/3.

**Speakers P.M.**—3 ohms 2 1/2" E.M.I. 15/8. Goodmans 3 1/2" 16/8. 5" Rola 15/8. 6" Elac 16/8. 7" x 4" Goodmans 15/8. 8" Rola 19/8. 10" R. x A. 25/-.  
 9" x 6" Goodmans 22/8. E.M.I. Ceramic Magnet 37/8. Tweeter 22/8. Jack Plugs. Standard 2 1/2" Igranite Type, 2/6. Screened ditto, 3/3. Miniature scr. 1 1/2", 2/3. Sub-min. 1/3.



**RADIO COMPONENT SPECIALISTS**

70 Brigstock Rd., Thornton Heath, Surrey.  
 THO 2188. Terms C.W.O. or C.O.D. Post and Packing up to 1/2 lb. 9d.; 1 lb. 1/3; 3 lb. 2/3; 5 lb. 2/9; 8 lb. 3/6.

**TRANSISTOR COMPONENTS**

Midget I.F.'s—465 Kc/s 1/8 in. diam. .... 5/3  
 Osc. Coil M. & L.W. .... 5/9  
 Midget Driver Trans. 3.5:1 ..... 6/9  
 Midget Output Trans. Push-Pull—  
 3 ohms ..... 6/9  
 Elect. Condensers—Midget Type 1 mfd.-50  
 mfd. ea. 1/8, 100 mfd. 2/-, 12V.  
 Condensers 150 v. working: .01 mfd., .02  
 mfd., .03 mfd., .04 mfd. 9d.; .05 mfd.,  
 .1 mfd., 1/-; .25 mfd., 1/3; .5 mfd., 1/6, etc.  
 Midget Tuning Condensers. J.B. "OO" 208  
 pF and 176pF, 8/8; ditto with trimmers, 9/8.  
 J.B. 220pF and 105pF conc. slow motion  
 10/8. 365pF single 7/8.

**Condensers**—Silver Mica. All values 2pF to  
 1,000pF, 6d. each. Dittos Ceramics 9d. Tub.  
 450V T.C.C. etc. 0.001 mFd to 0.01 and  
 0.1/350V. 9d. 0.02-0.1/500V., 1/- 0.25 Hunt,  
 1/8. 0.5 T.C.C. 1/9, etc., etc. Close Tol.  
 8/Micas—10% 5pF-500pF, 8d. 600-5,000pF,  
 1/- 1% 2pF-100pF, 9d. 100pF-500pF, 11d.  
 575pF-5,000pF, 1/6. Resistors—Full Range  
 10 ohms-10 meg. ohms 20% 1/2 and 1/4 W, 3d.,  
 1/4 W, 5d. (Midget type modern rating)  
 1W, 6d., 2W, 9d. Hi-Stab. 5% 1/4 W, 1/4 W, 6d.  
 (100 ohms-1 meg). Other values 9d. 1% 1/4 W,  
 1/8, etc., etc.

**TRIMMERS, Ceramic (Compression Type)**—  
 30pF, 50pF, 70pF, 9d.; 100pF, 150pF, 1/3;  
 250pF, 1/6; 600pF, 1/9.

**PHILIPS. Bee Hive Type (conc. air spaced)**  
 —2-8pF, 1/-; 3-30pF, 1/-.

**KNOBS**—Modern Continental types. Brown  
 or Ivory with Gold Ring; 1" dia., 9d. each;  
 1 1/4", 1/- each; Brown or Ivory with Gold  
 Centre, 1" dia., 10d. each; 1 1/4", 1/3 each.  
**LARGE SELECTION AVAILABLE.**

**METAL RECTIFIERS, STC Types**—RM1,  
 4/8; RM2, 8/8; RM3, 7/8; RM4, 16/8; RM5,  
 21/-; RM4B, 17/8; Mullard BY100, 10/8.

**TUB-ELECTROLYTICS-CAN**

25/25v. 50/12v. 1/9; 8+8/450v. 4/8; 50/50v.  
 100/125v. 2/-; 32+32/275v. 4/8; 8/450v.  
 4/350v. 2/3; 50/50/350v. 6/8; 16+16/450v.  
 5/8; 80/250/275v. 12/8; 32+32/450v. 8/6.  
 100+200/275v. 12/6.

**FRANCIS OF STREATHAM**

include among their customers many who call personally from all over the country, because of the stocks and service in TAPE AND HI-FI EQUIPMENT to be found there. With so many shops to choose from, there must be excellent reasons why people prefer to buy from Francis. Perhaps you would care to find out by calling or writing to us about your requirements.

- ★ VERY LARGE STOCKS OF TAPE AND HI-FI EQUIPMENT
- ★ NO EXTRA FOR CREDIT UP TO 18 MONTHS
- ★ OWN SERVICE DEPARTMENT
- ★ FREE SERVICE DURING GUARANTEE PERIOD

**FRANCIS OF STREATHAM**  
 169-173 STREATHAM HIGH ROAD, LONDON, S.W.16

Between St. Leonards Church and Streatham Stn. • Open all day Saturday • Phone STR 0192'0466

**HEAVY DUTY SHROUDED AUTO TRANSFORMERS, 240-110 V.** Fitted with 2 pin American sockets or terminal blocks. State which type. Brand new and Guaranteed. 1,000 watts, £4.15.0, carr. 5/-; 500 watts, £3.10.0, carr. 4/-; 300 watts, £2.7.6, carr. 3/6; 150 watts, £1.17.6, carr. 3/-.

2 KV. In metal case, with handle, 2 American socket outputs, £9.10.0. Carr. 7/6.

**EX-MINISTRY INDUSTRIAL TYPES.**  
 Tapped 250, 240, 230, 220, 120, 115, 110, 105 volts 10 KVA, £29.10.0; 5 KVA £19.10.0. Ex warehouse. Both types enclosed in heavy metal case.

We have London's largest selection of Low Tension Transformers, Variable Voltage Transformers, Smoothing Chokes, Capacitors, Sliding Resistors, Low Tension D.C. Supply Units. Send for lists now, or visit our walk round dept., where we have thousands of genuine electronic bargains.

**L.T. TRANSFORMERS**

Pri. tapped 200-260 v. Sec. tapped 28, 29, 30, 31 v. 25 amps, conservatively rated, £6.19.6, carr. 10/-; Pri. 200-250 v. Sec. 25-0-25 v. 7 amps, pri. earth shielded, £5.17.6, carr. 7/6; Pri. tapped 200, 225, 240 v. Sec. tapped 12, 18, 24, 30, 36 v. 10 amps, £5.15.0, carr. 7/6; Pri. 240 v. Sec. tapped 4, 6, 11 v. 200 amps, £10.19.6, carr. 10/-; Pri. 240 v. Sec. tapped 53.5, 55.2 v. 6 amps, £3.17.6, carr. 7/6; Pri. 220-240 v. Sec. tapped 6-12 v. 20 amps, £3.12.6, carr. 6/-; Pri. 230 v. Sec. 70 v. 5 amp. "C" core sealed, £4.5.0, c. 7/6. Hundreds more available. Send for list now.

**SAMSON'S ELECTRONICS LTD.**

9-10 CHAPEL STREET LONDON, N.W.1. Tel. PAD 7851 Tel. AMB 5125



**T615 PORTABLE 12v. TRANSISTOR AMPLIFIER**  
 15wt. OUTPUT  
 INBUILT MICROPHONE  
 PRE-AMPLIFIER

Details and Nearest Stockist from:

**Messrs. E. K. ELECTRONICS (I.A.) LTD.**  
**BROTHERTON HALL, BROTHERTON**  
**KNOTTINGLEY, YORKSHIRE**



# Z & I AERO SERVICES LTD.

Head Office and Warehouse: 44A WESTBOURNE GROVE, LONDON, W.2.

Retail Shop:  
85 TOTTENHAM COURT ROAD, LONDON, W.1.  
Tel.: LANgham 8403

Tel.: PARK 5641/2/3

OA2 6/-	5V4G 8/-	6BS7 16/-	6SK7GT 4/8	12AU6 6/-	30C17 12/-	6146 27/8	E180CC 8/-	EF42 6/-	EY51 7/-	PCL85 9/-	U301 12/-
OB2 6/-	5Y3GT 5/-	6BW6 9/-	6SL7GT 5/8	12AU7 5/8	30C18 10/8	A2293 15/8	E180F 15/-	EF54 6/-	EY70 12/8	PCL86 9/-	U403 7/8
OB3 6/-	5Z3 6/-	6BW7 9/-	6SN7GT 4/8	12AV6 8/-	30F5 9/-	AC/THI 10/-	EABC80 7/-	EF55 8/-	EY81 8/-	PL36 10/-	U801 18/-
OC3 6/-	5Z4GT 8/-	6C4 8/6	6U4GT 10/8	12AV7 8/-	30FL1 11/-	ACHLDD8/-	EAF42 8/8	EF80 5/-	EY83 9/8	PL38 18/-	U4020 7/8
OD3 5/-	6/30L2 10/-	6C8G 7/8	6U8 7/8	12AX7 8/-	30L15 12/-	OBL1 15/-	ER41 5/-	EF83 10/-	EY86 8/8	PL81 7/-	UABC80 8/-
1A5GT 5/-	6A3 8/-	6C31 12/-	6U8A 9/-	12AY7 10/-	30L17 13/-	CL33 9/-	EBC33 7/-	EF85 6/-	EZ35 5/8	PL82 6/-	UAF42 8/-
1A7GT 8/-	6A6 4/-	6CB6 5/-	6V6 9/-	12B4A 9/-	30P12 10/-	GY31 6/8	EBC41 7/-	EF86 7/-	EZ40 6/-	PL83 8/8	URC41 7/-
1AD4 7/-	6A8 8/-	6CD6GA17/-	6V6G 5/-	12BA6 8/-	30P19 14/-	DAC32 7/-	EBC81 6/8	EF89 4/8	EZ41 6/8	PL84 6/8	UBC81 7/-
1B3GT 7/-	6AB4 6/8	6CLE 9/-	6V6GT 7/8	12BE6 5/8	30PL1 11/8	DAF91 4/8	EBF80 6/8	EF91 4/-	EZ80 5/8	PL500 15/-	UBF80 6/8
1D6 8/-	6AB7 4/-	6CW4 12/-	6X4 4/-	12BH7 8/-	30PL13 11/-	DAF92 6/-	EBF83 7/8	EF93 4/9	EZ81 4/8	PY33 9/-	UBF89 7/-
1G6GT 7/-	6A07 3/-	6D3 7/8	6X5GT 5/8	12BY7 10/-	35C5 6/8	DAF96 6/-	EBF89 6/9	EF94 6/-	GZ30 8/8	PY81 6/-	URL21 11/-
1H4GT 6/-	6AF4 11/-	6D4 15/-	6Y6G 6/-	12E1 20/-	35L6GT 7/-	DAF96 6/-	EBL1 14/-	EF95 5/8	GZ32 10/-	PY82 6/-	UC93 6/-
1H5GT 7/-	6AG6G 12/8	6DK6 6/-	7B6 11/-	12F5GT 8/-	35W4 5/-	DCC90 7/-	ECL21 11/-	EF98 10/-	GZ34 10/-	PY83 6/-	UCC84 9/-
1L4 2/8	6AG7 8/-	6D84 15/-	7B7 8/-	12J5GT 3/-	35Z3 10/-	DF33 8/-	ECL88 12/-	EF183 8/-	HABC80 8/-	PY88 8/8	UCC85 7/-
1L6 17/-	6AH6 10/-	6E5 7/-	7C5 10/-	12J7GT 7/8	35Z4G 4/-	DF66 6/-	EC90 2/8	EF184 8/-	KT66 15/-	PY800 8/8	UCF80 9/8
1N5GT 8/-	6AK5 5/8	6EA8 8/-	7D3 8/-	12K7GT 7/-	35Z4GT 6/8	DF72 7/-	EC91 5/-	EFP60 10/-	KT88 20/-	PX25 10/-	UCH21 8/8
1Q5GT 8/-	6AK6 7/8	6EV5 12/-	7D5 8/-	12K8 10/-	35Z5GT 6/-	DF73 7/-	EC92 6/8	EL33 12/8	MU12/14 8/-	QQV03/10 35/-	UCH81 7/-
1R4 8/-	6AM5 2/8	6F6 8/-	7D8 7/-	12Q7GT 5/-	42 5/-	DF91 3/-	ECC31 5/-	EL34 10/-	N78 15/-	R2 8/-	UCL82 8/-
1R5 5/-	6AM6 4/-	6F7 5/-	7K7 10/-	12R7 10/-	50A5 12/-	DF92 2/8	ECC32 4/-	EL35 5/-	NSP1 25/-	R10 15/-	UCL83 10/-
1R4 5/-	6AN5 10/-	6F8G 5/-	7R7 12/-	12S7 4/-	50B5 7/-	DF96 6/-	ECC40 9/-	EL36 9/-	NSP2 22/-	R17 8/-	UF41 7/8
1R5 4/8	6AQ5 8/-	6F11 6/-	7S7 18/-	12S7 4/-	50C5 6/8	DH63 6/-	ECC81 4/-	EL37 17/8	OCF71 24/-	R19 7/-	UF42 8/-
1T4 3/-	6AQ6 8/-	6F13 8/-	9BW6 7/-	12SK7 5/-	50CD6G25/-	DK82 8/-	ECC82 5/-	EL38 17/8	ORF12 12/-	RL18 12/8	UF43 8/-
1T5GT 6/-	6AR5 8/-	6F23 9/8	10C1 10/-	12SY7 6/-	50L6GT 6/8	DK40 11/-	ECC83 6/-	EL41 8/-	ORP60 10/-	TH41 10/-	UF80 6/8
1U4 5/-	6AR6 8/-	6F24 11/-	10C2 12/-	13D3 6/-	85A1 25/-	DK91 5/-	ECC84 6/8	EL42 9/-	PC86 12/-	TH233 6/-	UF85 7/-
1U5 6/-	6AR6 5/-	6F28 10/-	10D1 7/-	19AQ5 5/-	85A2 8/8	DK92 9/-	ECC85 6/8	EL41 8/8	PC88 12/-	TH232 7/-	UF86 10/-
1X2A 7/-	6AS7G 22/8	6J4 9/-	10F1 14/-	19G3 25/-	85A3 5/8	DK96 7/8	ECC88 10/-	EL43 7/-	PC97 9/-	TP22 5/-	UF89 6/-
1X2B 7/-	6AT6 4/-	6J5G 4/-	10F3 8/-	19G6 15/-	150B2 12/-	DL66 12/-	ECF80 7/8	EL44 5/-	PCC84 6/8	TP25 5/-	UL41 8/-
2CW4 12/-	6AUG 6/-	6J6 3/8	10F9 10/-	20F2 15/-	150B3 8/-	DL68 10/-	ECF82 7/8	EL45 8/-	PCC85 7/-	TP2620 7/8	UL84 8/8
2D21 6/-	6AV6 6/-	6J7G 5/-	10F18 9/-	20L1 14/-	807 9/-	DL90 12/8	ECF86 10/-	EL46 7/8	PCC88 12/-	TT15 35/-	UM4 10/-
3A4 4/-	6B7 5/-	6J7GT 7/8	10L1 7/8	20P1 14/-	811 20/-	DL70 7/-	ECH21 10/-	EL49 6/-	PCC89 11/-	TT21 32/-	UM80 7/-
3A5 7/-	6B8 5/-	6K7 5/-	10LD11 10/-	20P3 12/-	832 20/-	DL73 12/-	ECH35 13/-	EL91 2/8	PCC189 10/-	TZ40 40/-	UU5 8/-
3B7 5/-	6BA6 4/9	6K7GT 5/-	10P13 12/8	20P4 14/-	954 5/-	DL75 10/-	ECH42 8/-	EL821 6/-	POF80 7/-	U12/14 8/-	UY21 8/-
3D6 4/-	6BA7 15/-	6K8GT 8/-	10P14 12/-	20P5 12/-	955 3/-	DL92 5/-	ECH81 6/-	EM4 10/-	PCF82 7/8	U22 6/-	UY21 8/-
3Q4 8/8	6BC4 17/8	6L6GA 7/8	11D3 7/-	25AGG 5/-	956 2/-	DL93 4/-	ECH83 7/8	EM31 5/-	PCF84 8/-	U25 11/-	UY41 6/-
3Q5GT 6/8	6BE6 5/-	6L7 5/-	11D5 7/-	25C5 10/-	957 5/-	DL94 5/8	ECL80 6/8	EM34 9/8	PCF86 9/-	U26 11/-	UY85 5/8
3R4 5/-	6BF6 6/-	6L18 8/-	11E3 25/-	25L6GT 8/-	958 4/-	DL95 6/8	ECL82 7/8	EM80 6/8	PCF801 10/-	U50 5/-	W81M 6/-
3V4 5/8	6BH6 7/-	6N7GT 6/-	12ACG 8/-	25Z4G 7/8	959 8/-	DL96 6/8	ECL83 9/-	EM81 7/8	PCF802 10/-	U76 4/-	X65 5/8
4D1 4/-	6BJ6 8/-	6P1 11/-	12AH7 5/-	25Z5 7/8	2050 12/8	DM70 5/-	ECL86 8/8	EM84 8/-	PCF805 10/8	U191 11/-	X66 8/-
4THA 10/-	6BK7A 8/-	6Q7G 6/-	12AH8 11/-	25Z6GT 8/8	2051 6/-	DY86 8/-	EF36 4/8	EM85 9/-	PCF806 13/-	U251 12/8	X79 20/-
5R4GY 9/-	6BN6 7/-	6SA7 8/-	12AL5 7/-	27M1 60/-	5696 6/-	E88CC 14/-	EF37A 8/-	EM87 7/-	PCL81 9/-	U281 13/-	Z66 10/-
5T4 8/-	6BQ7A 8/-	6SC7 9/-	12AQ5 7/-	28D7 7/-	5763 12/-	E90CC 12/-	EF39 5/-	EN31 10/-	PCL82 7/-	U282 14/-	Z759 22/-
6U4G 5/-	6BR7 11/8	6SG7 6/-	12AT6 5/-	29C1 20/-	6060 6/-	E91H 12/-	EF40 9/-	EN32 10/-	PCL83 8/3		
5U4GB 6/8	6BR8 5/-	6SJ7 8/-	12AT7 4/-	30C15 10/-	6080 25/-	E92CC 7/-	EF41 7/8	EN92 6/-	PCL84 8/-		

AF114 9/-	OC26 8/-	OC42 8/-	OC72 8/-	OC170 8/-	OC204 10/8	DIODES: OA5 4/8; OA79 2/3; OA81 2/-; OA85 3/-; OA86 3/8; OA202 5/-; CG10E 1/8;
AF115 8/8	OC28 17/8	OC44 6/-	OC75 8/-	OC171 9/-	Set of 2	GEX23 1/8; GEX54 2/-; SX641 3/-; SX642 3/8; SX645 15/-; SX781 4/8; CS8A 10/-;
AF116 8/-	OC29 17/8	OC45 6/-	OC76 6/-	OC200 10/8	matched	SILICON RECTIFIERS: BY100 7/-; BY210 7/8; OA210 6/8; OA211 9/8; DD006 6/8.
AF117 7/8	OC35 15/-	OC70 5/-	OC77 8/-	OC202 15/-	OC81 and 1	GERMANIUM RECTIFIERS: GJ3M, GJ5M, GJ7M, all at 3/8.
AF118 20/-	OC36 15/-	OC71 5/-	OC139 12/-	OC203 14/-	OC81D 12/8	ZENNER DIODES: VR425, VR475, VR575, VR7, VR9 all at 6/8. OAZ202 6/-; OAZ203 7/-; OAZ204 6/8; OAZ205, OAZ208, OAZ210 8/-; OAZ211 5/8; OAZ213 6/8.

All our valves carry three months' guarantee. Any faulty item replaced free of charge. We urgently need Klystrons 723A/B and 2K25. £1 paid subject to test. Please add 2/6 in £ for postage. Minimum charge 1/6. No C.O.D. Orders Accepted. Please address all correspondence to the Head Office.

# EVERYTHING YOU NEED...

from **direct TV Replacements LTD**

Dept. P.E., 126 Hamilton Road, West Norwood, London, S.E.27  
Telephone: GIPsy Hill 6166 (PBX)

## TRANSDUCERS

As specified for use in the Ultrasonic Control System featured in the December 1964 issue. Ultrasonic Transducers can be used for simple remote control without cables or electronic links, two units only being required. The Transducers are suitable for both transmitting and receiving. Ideally suited for the experimenter and designer for remote control systems



**55/-** or two of all kinds. Free TX/RX circuit with each order.  
each Components for use with the Transducers:  
QHf9 Transformer ... 4/- each  
Set of 7 transistors ... at 5/- each  
Low current reed relay and coil ... 25/6 each

## BEUKIT



Complete Kit of parts to enable you to build your own Television Camera. A step-by-step Instruction Book makes the building easy. Sends signals by 80 ohm coaxial cable up to 1/4 mile without additional amplification. 405 or 525/625 line C.C.I.R. system. Completely transistorised. Horizontal Resolution 2.5 m/cs. Can be used with domestic T.V. Receivers.  
**Experimenter's Vidicon Tube £12. Television Lens £13.19.0. Less Vidicon Tube and Lens £40**

## TRANSISTOR TESTER

The Unique **D.909**



Tests Alpha Gain (A.C. Gain) and Beta Gain (D.C. Gain) with transistors in place. Facilities also provided for testing leakage between Collector and Emitter and Collector Base. Exclusive Variable Voltage Smoothed D.C. Power Supply, continuously variable from 0/25 v. up to 25mA. Output voltage can be used as centre-tapped voltage supply enabling modern transistorised receivers to be tested.  
**£10 each**  
Send large S.A.E. for detailed leaflet



**QUALITY RECORD PLAYER AMPLIFIER**

A top-quality record player amplifier. This amplifier (which is used in a 29 gn. record player) employs heavy duty double wound mains transformer, ECC83, EL84, EZ80 valves. Separate Bass, Treble and Volume controls. Complete with output transformer matched for 3 ohm speaker. Size 7in. w. x 2½ in. d. x 5½ in. h. Ready built and tested. PRICE 69/6. P. & P. 3/6.

ALSO AVAILABLE mounted on board with output transformer and 6in. speaker ready to fit into cabinet below. PRICE 89/6. P. & P. 4/6.

**QUALITY PORTABLE R/P CABINET**

Uncut motor board. Will take above amplifier and B.S.R. or GARRARD Autochanger or Single Record Player Unit. Size 18 x 14 x 8½ in. PRICE £39/6. Carr. 5/-.

**4-SPEED PLAYER UNIT BARGAINS**

All brand new in maker's original packing.

**SINGLE PLAYERS**

B.S.R. TU12 ..... £39/6. Carr. 4/-  
GARRARD SRP10 ..... £59/11. Carr. 4/-  
B.S.R. GU7 with unit mounted pickup arm. £418/8. Carr. 4/-

**AUTO. CHANGERS**

B.S.R. UA15 £619/6. B.S.R. UA16 ..... £6 19 6  
Latest B.S.R. UA25 Super slim ..... £6 2 6  
Latest GARRARD AT5 ..... £8 8 0  
GARRARD AT6 ..... £10 10 0  
GARRARD Auto-Slim £6.10.0. Carr. 5/- on each.

All the above units are complete with t/o mono head and sapphire styli or can be supplied with compatible stereo head for 12/6 extra.

**BRAND NEW CARTRIDGE BARGAINS!**

GARRARD GC2 MONO complete. List price 24/11. Our price 12/6. P. & P. 1/-.

B.S.R. TC85 High output compatible STEREO CARTRIDGE. Brand new. Complete Stereo/LP/78 sapphire styli and universal mounting bracket. Original list price 44/11. Our price 22/6. P. & P. 1/-.

**RONETTE STEREO 105 CARTRIDGE**

Stereo/LP/78 complete with two sapphires. Original list price 67/9. Our price 24/-. P. & P. 1/-.

**PRECISION 6 MINUTE DELAY ACTION SWITCH.**

Clockwork actuated. Made by Smiths Separate switching actions at intervals up to 6 mins. Each switch action designed for current loading up to 15 amps at 250v. Suitable for photo timer, sequence switching ops, etc., etc. Brand new and unused. Offered at fraction of true value. OUR PRICE 10/- each. Post Free. 2 for 17/6. Special quotations for quantity.

**BRAND NEW 3 OHM LOUDSPEAKERS**

2½ in., 12/6; 5 in., 12/6; 6½ in., 15/-; 8 in., 21/-; 10 in., 25/-; 12 in., 27/6; (12 in. 15 ohm, 30/-). 10 in. x 6 in., 26/-.

Latest type E.M.I. 13½ x 8 in. with high flux ceramic magnet, 11,000 gauss. Aluminium centre cone. 10 watts, 50 c/s to 10 Kc/s., 42/-.

P. & P. up to 6 in., 1/6; over 6 in., 2/6 per speaker.

ROLA CELESTION. Approx. 9 in. x 6 in. 3 ohm. Middle register speaker, 10/6. P. & P. 2/6.

ACOS CRYSTAL MIKES. High imp. For desk or hand use. High sensitivity, 18/6. P. & P. 1/6.

TSL CRYSTAL STICK MIKE. Listed at 45/-. Our price, 18/6. P. & P. 1/6.

TRANSISTOR DRIVER and O/P TRANSFORMERS. (Tapped 3 ohms and 15 ohms output). Plus 4 suitable Transistors giving approx. 1 watt output, 25/- P. & P. 2/6.

MATCHED PAIR OF 2 WATT TRANSISTOR DRIVER AND OUTPUT TRANSFORMERS. Stack size 1½ x 1½ x 1 in. Output trans. tapped for 3 ohm and 15 ohm output. 10/- pair plus 2/- P. & P. Worth double.

BRAND NEW PLESSEY 12 v. 4 pin non-sync. vibrators. Type 12 L.45D. ONLY 8/6. P. & P. 1/6 each.

2-GANG .0005 TUNING CONDENSERS 2½ in. h. x 2½ in. d. x 1½ in. w. with built in trimmer, 4/6. P. & P. 1/-.

**STEREO AMPLIFIER**

Incorporating 2 ECL82s and 1 EZ80, heavy duty, double wound mains transformer. Output 4 watts per channel. Full tone and volume controls. Absolutely complete.

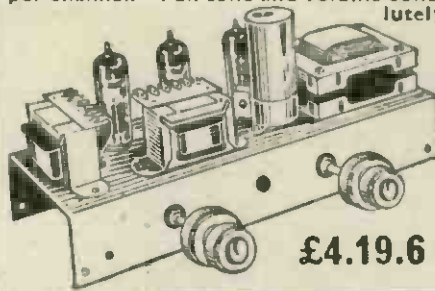

**BARGAIN PRICE ONLY**

£4.19.6 P. & P. 5/-

**HIGH GAIN 4 TRANSISTOR PRINTED CIRCUIT AMPLIFIER KIT**

Type TAI



- Peak output in excess of 1½ watts.
- All standard British components.
- Built on printed circuit panel, size 6 x 3 in.
- Generous size Driver and Output Transformers.
- Output transformer tapped for 3 ohm and 15 ohm speakers.
- Transistors (GET 114 or S1 Mullard OC81D and matched pair of OC81 o/p).
- 9 volt operation.
- Everything supplied, wire, battery clips, solder, etc.
- Comprehensive easy to follow instructions and circuit diagram 1/6 (Free with Kit). All parts sold separately.

**SPECIAL PRICE 45/-** P. & P. 2/6. Also ready built and tested, 52/6. P. & P. 2/6. A pair of TAIs are ideal for stereo.

**TAPE DECKS**

B.S.R. MONARDECK (Single speed) 3½ in. per sec., simple control, uses 5½ in. spools, £6/15/- plus 5/6 carr. and ins.

COLLARO STUDIO DECK 3 motors, 3 speeds push button control. Up to 7 in. spools £10/10/- P. & P. 5/6. (Tapes extra on both.)

**10/14 WATT HI-FI AMPLIFIER KIT**

A stylishly finished monaural amplifier with an output of 14 watts from 2 EL84s in push-pull. Super reproduction of both music and speech, with negligible hum. Separate inputs for mike and gram allow records and announcements to follow each other. Fully shrouded section wound output transformer to match 3-15Ω speaker and 2 independent volume controls, and separate bass and treble controls are provided giving good lift and cut. Valve line-up 2 EL84s, ECC83, EF86, and EZ80 rectifier. Simple instruction booklet 1/6. (Free with parts.) All parts sold separately. ONLY £6/19/6. P. & P. 6/6. Also available ready built and tested complete with std. input sockets, £8/15/- P. & P. 6/6.

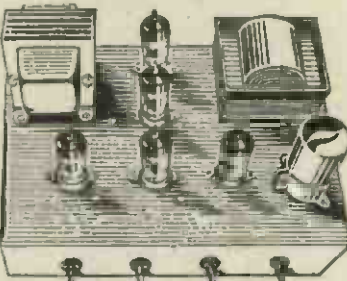

**3-VALVE AUDIO AMPLIFIER**

**MODEL HA34**

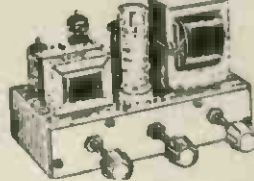

Designed for Hi-Fi reproduction of records. A.C. Mains operation. Ready built on plated heavy gauge metal chassis, size 7½ in. w. x 4 in. d. x 4½ in. h. Incorporates ECC83, EL84, EZ80 valves. Heavy duty, double wound mains transformer and output transformer matched for 3 ohm speaker, separate Bass, Treble and volume controls. Negative feedback line. Output 4½ watts. Front panel can be detached and leads extended for remote mounting of controls.

The HA34 has been specially designed for us and our quantity order enables us to offer them complete with knobs, valves, etc., wired and tested for only **£4.5.0** P. & P. 5/-.

**HSL 'FOUR' AMPLIFIER KIT.**

A.C. Mains 200/250v., 4 watt, using ECC83, EL84, EZ80 valves.

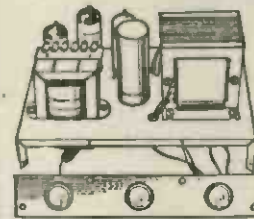

- ★ Heavy duty double-wound mains transformer with electrostatic screen.
- ★ Separate Bass, Treble and Volume controls, giving fully variable boost and cut with minimum insertion loss.
- ★ Heavy negative feedback loop over 2 stages ensures high output at excellent quality with very low distortion factor.
- ★ Suitable for use with guitar, microphone or record player
- ★ Provision for remote mounting of controls or direct on chassis.
- ★ Chassis size only 7½ in. wide x 4 in. deep. Overall height 4½ in.
- ★ All components and valves are brand new.
- ★ Very clear and concise instructions enable even the inexperienced amateur to construct with 100% success.
- ★ Supplied complete with valves, output transformer (3 ohms only), screened lead, wire, nuts, bolts, solder, etc. (No extras to buy.) PRICE 79/6. P. & P. 5/-.

Comprehensive circuit diagram, practical layout and parts list 2/6 (free with kit).

**HARVERSON'S F.M. TUNER Mk. I**

- F.M. tuning head by famous maker.
- Guaranteed non-drift.
- Permeability tuning
- Frequency coverage 88-100 Mc/s
- OAB1 balanced diode output
- Two I.F. stages and discriminator.

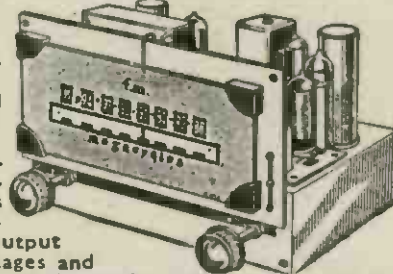

- Attractive maroon and gold dial (7 x 3 in. glass).
- Self powered, using a good quality mains transformer and valve rectifier.
- Valves used ECC85, two EF80s, and EZ80 (rectifier)
- Fully drilled chassis.
- Size of completed tuner 8 x 6 x 5½ in.
- All parts sold separately. Set of parts if purchased at one time £5/19/6, plus 8/6 P.P. and ins. Circuit diagram and instructions 1/6 post free. Mark II Version as above but complete with magic eye, front panel and brackets, £6/12/6. P. & P. 8/6.
- Mark III Version as Mark I but with output stage (ECL82) and tone control, £7/7/- P. & P. 8/6.

Handsome Metal Cabinets. Choice of Black, or Green. To fit Mark I, 25/- P. & P. 2/6. To fit Mark II, 17/6. P. & P. 2/6.

**HARVERSON SURPLUS CO. LTD.**

170 HIGH ST., MERTON, S.W.19. CHerrywood 3985

Open all day Saturday Early closing Wed., 1 p.m.

A few minutes from South Wimbledon Tube Station. (Please write clearly) OVERSEAS P. & P. CHARGED EXTRA. S.A.E. with all enquiries.

**SPECIAL PURCHASE**

**TURRET TUNERS**

By famous maker. Brand new and unused. Complete with PCC84 and PCF80 valves, 34-38 Mc/s I.F. Bis-cuits for Channels 1 to 5 and 8 and 9. Circuit diagram supplied. ONLY 25/- each. P. & P. 2/6.

**BLANK CHASSIS**

Precision made in our own works from commercial quality half-hard Aluminium. Two, three or four sided. SAME DAY SERVICE of over 20 different forms made up to YOUR SIZE.

Order EXACT size you require to nearest 1/16" (maximum length 35", depth 4"). Specials dealt with promptly. SEND FOR ILLUSTRATED LEAFLETS or order straight away, working out total area of material required and referring to table below, which is for four-sided chassis in 18 s.w.g. (for 16 s.w.g. add 3/4th)

48 sq. in. 4/-	176 sq. in. 8/-	304 sq. in. 12/-
80 sq. in. 5/-	208 sq. in. 9/-	336 sq. in. 13/-
112 sq. in. 6/-	240 sq. in. 10/-	368 sq. in. 14/-
144 sq. in. 7/-	272 sq. in. 11/-	and pro rata
P. & P. 2/6	P. & P. 2/9	P. & P. 3/-

FLANGES (½", ¾" or 1") 6d. per bend.

STRENGTHENED CORNERS 1/- each corner.

PANELS. The same material can be supplied for panels, screens, etc., at 4/6 sq. ft. (16 s.w.g., 5/3) plus P. & P. (over £2 post free)

**H. L. SMITH & CO. LTD.**

287-289 EDGWARE ROAD, LONDON, W.1 — PAD 5298/7395



**A.C. PANEL VOLTMETERS**

- ★ 0-300v. High quality rectifier movement.
- ★ Superior finish black bakelite case with silver scale plate. Flush mounting overall diam. 3½ in. inc. p.p. 30/-

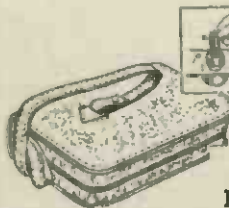

**CHASSIS PUNCH SETS**

Superior quality tool steel kit consisting 5 punches, ½"-1"-1½"-1"-1½", taper reamer and tommy bar. In high quality leather zip case. 47/6 inc. p.p.

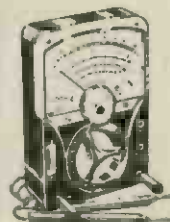

**TMK - 500 MULTIMETER**

30,000 Ω/per v.

★ ★ ★

A magnificent instrument worth double its price! Has the following full scale ranges:

D.C. volts: 5/12.5/10/25/100/250/500/1000 A.C. volts: 2.5/10/25/100/250/500/1000. D.C. amps: 50μA/5ma/50ma/500ma/12A. Resistance: 60kΩ/6 meg/60 meg.

Brand New—Fully Guaranteed—Complete with batteries. Also incorporates an off position which completely damps movement thus avoiding transit damage.

£7.19.6 inc. p.p.

**ELECTROSURE LTD.**

FORE ST. EXETER



## A QUALITY RECORD PLAYER FOR 10 GNS.!!

(FULLY AUTOMATIC) ASSEMBLED IN 30 MINS.

REF. No. K116. Fully Auto.

Cabinet Size 16" x 15 1/4" x 8".

Complete Kit 10 gns. + P.P. 6/6 includes very latest B.S.R.UA.25 Superslim. Tasteful cabinet in 2 tone Rexine. Vynair and Gold/White Trim. Cut out Motor Board. 7" x 4" P.M. Loudspeaker. Printed circuit amplifier. Double wound. Mains TX AC 240 volts. Entirely safe and reliable. Separate Switch tone and volume controls. 6 simple connections to make. FULL instructions supplied. Guaranteed 12 months. Complete down to the last washer!!

REF. K.82 De Luxe Version of above. Cabinet 17" x 15 1/2" x 8" of pleasing design. Includes 8" x 5" top quality Loudspeaker and Hi-Fi performance Amplifier. 11 1/2 gns. + P.P. 6/6.

REF. K.500 Single Record Player. ONLY £8-0-0 + P.P. 6/6. Cabinet 14" x 13" x 6 1/2". N.B. Plays 12" record with lid closed. Complete with T.U./2 Single Record Player. Other details as K.116.

### RECORD PLAYER AND TAPE DECK UNITS

BSR Monarch UA14	£6.6.0
BSR Monarch UA15	£6.19.6
The new BSR Monarch UA1588 fitted with C1 ceramic stereo cartridge	£10.18.11
TD2 Tape Deck, half track	£8.18.0
TD10 Tape Deck half track	£10.5.0
BSR Monarch TU12	£9.10.0
BSR Monarch GU7	£9.17.6
Garrard Autoslim	£7.15.0
Garrard AT6	£11.5.0
Garrard SRP10	£6.0.11

All the above are also available with stereo cartridges at slight extra cost.

#### TRANSISTORS

AC113	5/6	OA79	3/-	OC74	8/-
AC115	4/-	OA81	2/-	OC75	5/6
AC155	4/-	OA85	3/-	OC76	8/6
AC156	5/6	OA86	4/-	OC78	8/-
AC154	5/6	OA90	3/-	OC79	8/-
AC157	7/-	OA91	3/-	OC81	5/6
AD140	25/-	OA95	3/6	OC82	10/-
AF102	27/6	OC16W	35/-	OC83	4/-
AF114	11/-	OC19	25/-	OC84	8/-
AF115	10/6	OC26	25/-	OC139	8/-
AF116	5/6	OC35	12/-	OC140	19/-
AF117	9/6	OC38	21/6	OC141	31/-
AF118	20/-	OC41	8/-	OC169	10/-
AF124	11/-	OC42	6/-	OC170	8/6
AF125	10/6	OC43	12/6	OC171	6/-
AF126	10/-	OC44	5/-	OC200	10/6
AF127	9/6	OC45	5/-	OC201	29/-
BY100	7/6	OC70	6/6	OC202	24/6
BY111	8/-	OC71	4/3	OC203	13/-
GET113	8/6	OC72	5/6	OC204	19/-
GET114	6/6	OC82	8/-	MAT100	7/9
GET115	9/6	2xOC72		MAT101	8/6
GET116	17/-	matched		MAT120	7/9
OA70	3/-	pair	18/-	MAT121	8/6
OA73	3/-	OC73	18/-	ADT140	15/-

#### SETS OF TRANSISTORS

Set No. 1: comprising OC44, 2 x OC45, OC81, matched pair OC81 20/-.

Set No. 2: comprising OC81, matched pair OC81 12/6.

#### SIEMENS RECTIFIERS

B.30	C.400	9/4d
B.30	C.600	13/6d
B.30	C.1000	22/6d
E.250	C.50	8/3d
B.250	C.75	13/6d
E.250	C.85	11/3d
B.250	C.100	14/3d
B.250	C.125	15/5d
B.250	C.150	17/7d
B.250	C.250	22/4d
E.250	C.300	25/-d
B.300	C.120	24/2d

#### CHARGER RECTIFIERS

12 volt 1 amp contact cooled	5/6d
12 volt 1 1/2 amp fin type	6/9d
12 volt 2 amp fin type	7/6d
12 volt 4 amp fin type	12/6d
12 volt 6 amp fin type	16/-d

#### CATALOGUE

Our latest 1964/65 Catalogue is now available. Copies have been sent to many of our regular customers. If you have not received your copy please drop us a card. Please send 1/- in stamps. Wholesale terms to Schools, Universities and Business Houses. Trade Catalogue now available. Please apply on business letter heading.

#### WESTINGHOUSE RECTIFIERS

FC.31	(14RD-1-2-8-3)	26/6d
FC.116	(18RD-1-1-16-1)	7/6d
FC.117	(18RA-1-1-8-2)	12/6d
FC.118	(18RD-1-1-8-1)	5/-d
FC.124	(18RD-2-2-8-1)	16/4d
FC.130	(18RD-2-2-10-1)	19/-d
FC.141	(16RC-1-1-16-1)	10/8d
FC.142	(16RD-2-2-8-1)	12/10d
FC.144	(16RD-2-2-10-1)	14/8d
FC.146	(16RD-2-2-6-1)	12/-d
FC.148	(16RC-1-1-8-1)	4/10d
FC.150	(16RE-2-1-8-1)	10/8d

**TERMS:** Cash with Order or C.O.D. Postage and Packing Charges extra. Single valves 9d. Minimum Parcel Post charges 2/-. Please include sufficient postage with your order. Minimum C.O.D. fees and postage 3/6. These Postal Rates apply to U.K. only. For full terms of business see inside cover of catalogue. Personal shoppers 9 a.m. to 5 p.m. Mon. to Friday, Saturday 10 a.m. to 1 p.m.

ALPHA RADIO SUPPLY CO., 103 Leeds Terrace, Wintoun Street, LEEDS 7

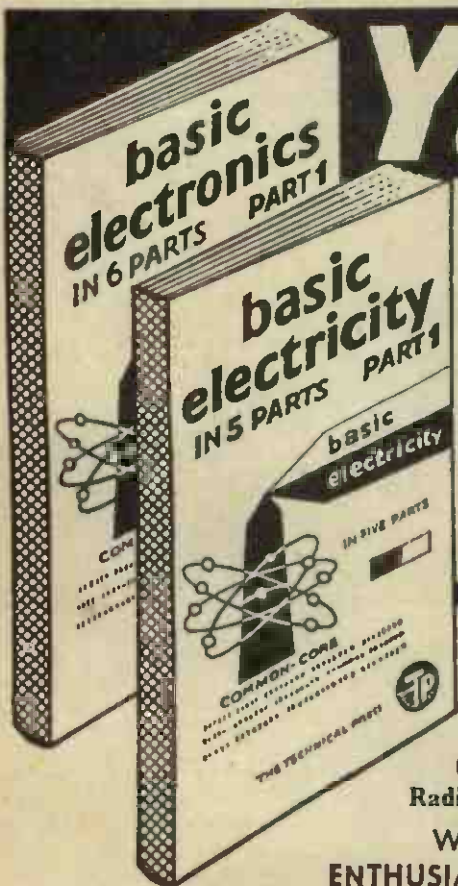

# YOURS FREE FOR 7 DAYS

## The New 'Picture-Book' way of learning BASIC ELECTRICITY (5 VOLS.) BASIC ELECTRONICS (6 VOLS.)

You'll find it easy to learn with this outstandingly successful new pictorial method—the essential facts are explained in the simplest language, one at a time; and each is illustrated by an accurate, cartoon-type drawing.

The books are based on the latest research into simplified learning techniques. This has proved that the Pictorial Approach to learning is the quickest and soundest way of gaining mastery over these subjects.

The series will be of exceptional value in training mechanics and technicians in Electricity, Radio and Electronics.

WHAT THIS MONTH'S ENTHUSIASTIC READERS SAY

Every day we receive letters praising these books. Here are a few from this month's post bag. "My ultimate aim is to understand Electronics and with your simple approach I am well on the way..." P. S. Y. Rainham. "The Manuals are the best value that money can buy in technical literature for the beginner and professional..." R. A. P. Orpington. "May I state how delighted I am with the Manuals and what a contrast to the many text books I have attempted to struggle through..." R. J. D. Bognor.

A TECH-PRESS PUBLICATION.

To Selray Book Co.  
60 Hayes Hill, Hayes, Bromley, Kent

Please send me Without Obligation to Purchase, Basic Electricity/Basic Electronics on 7 Days' Free Trial. I will either return set, carriage paid, in good condition within 8 days or send down payment of 15/- (Basic Electricity) followed by 6 fortnightly payments of 10/-. Down payment of 15/- (Basic Electronics) followed by 6 fortnightly payments of 12/6. Alternatively, I will send 68/- (Basic Electricity—5 parts). 81/- (Basic Electronics—6 parts) post free. This offer applies to United Kingdom only.

Tick against set required (only one set allowed on free trial).

BASIC ELECTRICITY  BASIC ELECTRONICS

Signature.....  
(If under 21, signature of parent or guardian)

Name.....  
BLOCK LETTERS BELOW

FULL POSTAL Address..... P.E.4

POST NOW FOR THIS OFFER!!

# VALUABLE NEW HANDBOOK FREE TO AMBITIOUS ENGINEERS

Have you had your copy of "Engineering Opportunities"?

The new edition of "ENGINEERING OPPORTUNITIES" is now available—without charge—to all who are anxious for a worthwhile post in Engineering. Frank, informative and completely up to date, the new "ENGINEERING OPPORTUNITIES" should be in the hands of every person engaged in any branch of the Engineering industry, irrespective of age, experience or training.

We definitely Guarantee  
"NO PASS—NO FEE"

This remarkable book gives details of examinations and courses in every branch of Engineering, Building, etc., outlines the openings available and describes our Special Appointments Department.

## WHICH OF THESE IS YOUR PET SUBJECT?

**MECH. ENGINEERING**  
Gen. Mech. Eng.—Maintenance Eng.—Diesel Eng.—Press Tool Design—Sheet Metal Work—Welding—Eng. Pattern Making—Inspection—Draughtsmanship—Metallurgy—Production Eng.

**RADIO ENGINEERING**  
General Radio—Radio & TV Servicing—TV Eng.—Telecommunications—Electronics—Sound Recording—Automation—Practical Radio—Radio Amateurs' Exam.

**CIVIL ENGINEERING**  
General Civil Eng.—Municipal Eng.—Structural Eng.—Sanitary Eng.—Road Eng.—Hydraulics—Mining—Water Supply—Petrol Tech.

**ELEC. ENGINEERING**  
General Electrical Eng.—Installations—Draughtsmanship—Illuminating Eng.—Refrigeration—Elem. Elec. Science—Elec. Supply—Mining Elec. Eng.

**AUTO ENGINEERING**  
General Auto Eng.—Auto. Maintenance—Repair—Auto. Diesel Maintenance—Auto. Electrical Equipment—Garage Management.

**BUILDING**  
General Building—Heating & Ventilation—Plumbing—Architecture—Carpentry—Painting—Decorating—Specifications & Quantities—Surveying—Architectural Draughtsmanship.

WE HAVE A WIDE RANGE OF COURSES IN OTHER SUBJECTS INCLUDING CHEMICAL ENG., AERO ENG., MANAGEMENT, INSTRUMENT TECHNOLOGY, WORKS STUDY, MATHEMATICS, ETC.

Which qualification would increase your earning power?  
A.M.I.Mech.E., A.M.S.E., A.M.I.C.E., A.M.I.E.R.E., B.Sc.,  
A.M.I.P.E., A.M.I.M.I., A.R.I.B.A., A.I.O.B., A.M.I.Chem.E., A.R.I.C.S.  
M.R.S.H., A.M.I.E.D., A.M.I.Mun.E., CITY & GUILDS, GEN. CERT. OF  
EDUCATION, ETC.

**BRITISH INSTITUTE OF ENGINEERING TECHNOLOGY**  
155 COLLEGE HOUSE, 29-31 WRIGHT'S LANE, W.8

## THIS BOOK TELLS YOU

- ★ HOW to get a better paid, more interesting job.
- ★ HOW to qualify for rapid promotion.
- ★ HOW to put some letters after your name and become a key man . . . quickly and easily.
- ★ HOW to benefit from our free Advisory and Appointments Depts.
- ★ HOW you can take advantage of the chances you are now missing.
- ★ HOW, irrespective of your age, education or experience, YOU can succeed in any branch of Engineering.

156 PAGES OF EXPERT  
CAREER - GUIDANCE

### PRACTICAL EQUIPMENT

Basic Practical and Theoretic Courses for beginners in Radio, T.V., Electronics, Etc., A.M.I.E.R.E. City & Guilds Radio Amateurs' Exam. R.T.E.B. Certificate P.M.G. Certificate Practical Radio Radio & Television Servicing Practical Electronics Electronics Engineering Automation

### INCLUDING TOOLS

The specialist Electronics Division of B.I.E.T. NOW offers you a real laboratory training at home with practical equipment. Ask for details.

**B.I.E.T.**

You are bound to benefit from reading "ENGINEERING OPPORTUNITIES", and if you are earning less than £30 a week you should send for your copy now—FREE and without obligation.



## POST NOW!

TO B.I.E.T., 155 COLLEGE HOUSE,  
29-31 WRIGHT'S LANE, W.8.

2d. stamp if posted in  
an unsealed envelope.

Please send me a FREE copy of "ENGINEERING OPPORTUNITIES." I am interested in (state subject, exam., or career).

NAME .....

ADDRESS .....

WRITE IF YOU PREFER NOT TO CUT THIS PAGE

**THE B.I.E.T. IS THE LEADING INSTITUTE OF ITS KIND IN THE WORLD**

Published about the 15th of the month by GEORGE NEWNES LIMITED, Tower House, Southampton Street, London, W.C.2. Printed in England by THE CHAPEL RIVER PRESS LIMITED, Andover, Hants. Sole Agents for Australia and New Zealand: GORDON & GOTCH (A/sia) Ltd.; South Africa and Rhodesia: CENTRAL NEWS AGENCY LTD.; East Africa: STATIONERY & OFFICE SUPPLIES LTD. Subscription rate including postage for one year: To any part of the World £1 15. 0.

# FIRST AND BEST

FULL AFTER SALES SERVICE AND GUARANTEE - CALL FOR DEMONSTRATION

# PROVED and TESTED CIRCUITS QUALITY COMPONENTS and UNITS

## TRANSISTOR HIGH FIDELITY EQUIPMENT

MONO or STEREO

10 WATTS and 20 WATTS

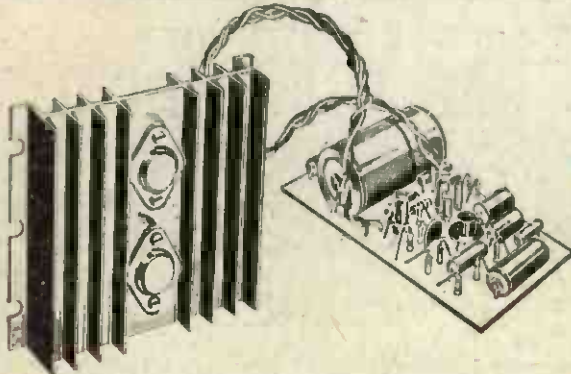

★ 10 watt Power Amplifier  
(For 15/16 ohm SPEAKERS)

BUILT £5.19.6 P.P. 2/6  
(KIT £5.10.0 P.P. 2/6)

★ 10 watt Power Amplifier  
(For 3 to 5 ohm SPEAKERS)

BUILT £5.10.0 P.P. 2/6  
(KIT 99/6 P.P. 2/6)

★ MAINS UNITS 59/6 for one amplifier, or 69/6 to power 2 amplifiers.

● Mono full function pre-amplifier with 8 input positions. Low noise, high quality. 1 1/2 mV sensitivity. Gives 10 watts with one power amplifier or 20 watts with two amplifiers. Size: 9 x 2 1/2 x 2 in.

BUILT £5.10.0 P.P. 2/-  
(KIT 99/6 P.P. 2/-)



## PREAMPLIFIERS



★ Dark Brown with Gold panel plate 8/6.

● STEREO PREAMPLIFIER  
Two channel version of above. For use with two power amplifiers. For 10 + 10 watts output. Size: 9 x 3 1/4 x 1 1/8 in.

PRICE BUILT £10.19.6 P.P. 3/6

★ Dark Brown with Gold Front Panel 12/6.

## MULTI-INPUT PREAMPLIFIER

Simplified preamplifier for use with one or two power amplifiers, 8 inputs.

PRICE BUILT 65/- P.P. 1/6

★ Front Panel Plate 6/6.

All the above preamplifiers can be used with any valve or transistor power amplifier requiring 250mV or full output. They can be operated with two 9 volt batteries in series or from the power amplifiers. All preamplifiers and power amplifiers are designed for high gain low distortion with excellent quality.

20 WATTS PEAK MUSIC POWER PER CHANNEL

CIRCUITS AND DETAILS ON REQUEST

## TWO PACKAGED TRANSISTOR QUALITY AMPLIFIERS

★ NEW. Mains unit for 4 watt amplifier 52/6

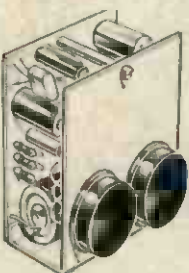

● 6-Transistor printed circuit designs. Push-pull output for 3 to 5 ohm speakers. Can be battery operated. 6mV into 1 Kohm sensitivity. Response 40 c/s to 15 kc/s. Outputs are 1 1/2 watts and 4 watts RMS. Can be used with above preamplifiers for mono or stereo in any application requiring a low distortion low cost amplifier.

OVERALL SIZES 2 1/2 x 2 x 1 1/4 inches.

● 4 watt version operates from 12 to 18 volts.

PRICE BUILT 79/6 P.P. 1/6

● 1 1/2 watt version operates from 9 to 12 volts.

PRICE BUILT 65/- P.P. 1/6

★ CIRCUITS AND DETAILS ON REQUEST ★

4 WATT and 1 1/2 WATT

We can supply from stock most of the components and items specified on circuits published in this and other magazines. Quality parts at realistic prices. Let us quote for your circuit.

300 TRANSISTOR TYPES, DIODES AND RECTIFIERS  
800 VALVES AND TUBES  
500 QUARTZ CRYSTALS

## "REGENT 6" MW/LW POCKET RADIO

Covers all Med./Long Waves

A new printed circuit Pocket Radio design. Features 6 matched transistors and diode with push-pull 'Cleartone' speaker output, geared tuning, Hi-flux speaker, etc. Fitted phone socket, separate wave-change switch. Easy to follow building instructions. Moulded two-tone cabinet size 5" x 3" x 1 1/4". All parts sold separately and guaranteed. After sales service.

CIRCUIT AND DETAILS ON REQUEST.

★ Total cost to build 85/- P.P. 2/- (Battery 2/6 extra)

NEW!  
● 6 TRANSISTOR SUPERHET



## ALL TRANSISTOR CAR RADIO

● 1 HOUR TO BUILD WITH PRE-ASSEMBLED CHASSIS AND PANELS

6-Transistor 3 diode med. and long wave superhet design. Features double tuned IFTS, AVC, permeability tuning with geared drive. Push-pull car filling volume. Full tuning on both wavebands. A high sensitivity printed circuit professional design to fit any type of vehicle. Case size 7 x 4 x 2 in. For 12 volt positive earth or dry battery. All parts available separately. After sales service and guarantee.



THE "ROADSTER"

● TOTAL COST TO BUILD £8.19.6 P.P. 3/6

● 7 x 4 inch Hi-Flux speaker with baffle and car fixing kit 20/- extra  
CIRCUIT AND DETAILS ON REQUEST

## VHF TRANSISTOR FM TUNER

● HIGH STABILITY - HIGH SENSITIVITY ●

Features 5-Mullard transistors with 4 diodes, compact printed circuit, high gain, low distortion, superhet design. Full tuning from 87/105 Mc/s with geared tuning. AVC and AFC. 9 volt 9 mA operation. 50 dB S/N. Output up to 1 volt audio. Easy to build and align. Overall size in cabinet 3 1/2 x 2 1/2 x 4 in. All parts sold separately.

After sales service and guarantee.

★ CIRCUIT AND DETAILS ON REQUEST (Cabinet Assembly 20/- extra)

● New 6-Transistor FM design with factory pre-built units, horizontal tuning, AFC, etc. Leaflet on request. Total cost to build £12.17.6



● TOTAL COST WITH FRONT PANEL

To Build £6.19.6 P.P. 2/6

## 'CONVAIR' PUSH-BUTTON PORTABLE/CAR RADIO

● UNBEATABLE FOR PERFORMANCE AND DESIGN ●

Printed circuit 6-Transistor 2-Diode superhet radio with full tuning on medium and long wave bands. Quality push-pull output up to 1 watt. Attractive portable cabinet; size 10 x 7 x 3 1/2 in. with horizontal slow motion tuning dial and push button wave change. Easy to build with superb performance. All parts sold separately. After sales service and guarantee.

★ CIRCUIT AND DETAILS ON REQUEST



● TOTAL COST OF ALL PARTS

To Build £7.19.6 P.P. 3/6

(Batteries 6/- extra)

★ The finest portable available.

## BUILD A QUALITY TAPE RECORDER

● 6-valve printed circuit designs with Magic Eye - Collaro Studio 2-track or 4-track decks. Portable cabinets with 8 x 5 in. speakers. Complete in every detail.

TWO TRACK £26 8/6 P.P. 8/6  
FOUR TRACK £30 8/6 P.P. 8/6

★ DETAIL LEAFLET ON REQUEST ★

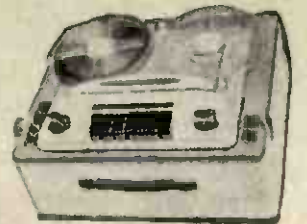

## ● SINCLAIR X10 in stock

KIT £5.19.6. BUILT £6.19.6. MICRO-6 59/6. TR 750 AMPLIFIER 39/6

## NEW CATALOGUE

90 PAGES, 10" x 7 1/4"  
Fully detailed and illustrated.  
Price 2/6 post paid.  
Latest 5th Edition fully revised and with more stock items

## HENRY'S RADIO LTD.

303 EDGWARE RD., LONDON W2

PADDINGTON 1008/9

Open Mon. to Sat. 9-6. Thurs. 1 o'clock