

To be Completed in about 32 weekly parts.

# NEWNES PRACTICAL ELECTRICAL ENGINEERING

PRACTICAL ELECTRICAL ENGINEERING

## IN THIS PART

INSTALLING  
WIRELESS SETS

MAINTENANCE OF  
AN ELECTRICALLY  
EQUIPPED RAILWAY  
STATION

MICA

ILLUMINATION OF  
SCHOOL BUILDINGS

FLOOD-LIGHTING

STARTERS AND  
CONTROL GEAR FOR  
A.C. INDUSTRIAL  
MOTORS

1/-

PART  
27

A PRACTICAL WORK WRITTEN BY EXPERTS

Worldradiohistory

# RALPH STRANGER'S WIRELESS BOOKS

*The Wireless Library for the  
Man in the Street:*

MATTER AND ENERGY  
ELECTRONIC CURRENTS  
ELECTRIFIED MATTER  
MAGNETISM AND ELECTRO-  
MAGNETISM  
BATTERIES AND ACCUMULATORS  
SEEING BY WIRELESS (TELEVISION)  
MODERN VALVES  
WIRELESS COMMUNICATION AND  
BROADCASTING  
WIRELESS WAVES  
HOW TO UNDERSTAND WIRELESS  
DIAGRAMS  
SELECTION OF WIRELESS SIGNALS  
DETECTION OF WIRELESS SIGNALS  
AMPLIFICATION OF WIRELESS SIGNALS  
REPRODUCTION OF WIRELESS SIGNALS  
WIRELESS RECEIVING CIRCUITS  
WIRELESS MEASURING INSTRUMENTS  
THE BY-PRODUCTS OF WIRELESS

**SOME PRESS OPINIONS:—**

"The new shilling library aims at giving the wireless enthusiast a sound theoretical and practical grip of his subject. The author employs clear and simple language, and starts practically from zero."—*The Broadcaster*.

"These books deal with a highly technical subject in the simplest language which enables those who have no scientific training to grasp the wonders of wireless, and assist the listener to get the best possible results from a receiving set."—*Railway Review*.

**ONE SHILLING EACH**

By Post 1/2 each.

## THE MATHEMATICS OF WIRELESS

This book is essential for the wireless amateur who desires to gain a fuller knowledge of his subject. Written by one who has the gift of explaining abstruse matters in a simple fashion, it will enable its readers to attempt research and experiments which at one time were far beyond their powers. 256 pages. Fully illustrated.

5/-, by post 5/3

## WIRELESS: THE MODERN MAGIC CARPET

Fourth and Revised Edition

If you know nothing about wireless and do not even possess a receiving set, this book will show you how to provide yourself with an interesting and absorbing hobby. If you are a listener, but rather weak on the technical side, it will save you much unnecessary worry and expense. If you wish to experiment, this volume will provide you with valuable experimental data. If you are an expert and have to lecture, it will give you some useful lecture material.

3/6, by post 3/9

On sale at all Newsagents, Bookstalls and Bookshops, or by post from GEORGE NEWNES,  
Ltd., 8-11, Southampton Street, Strand, London, W.C. 2.

directly in the anode circuit of the power valve and an extension is taken from the set into another room, high note loss and instability would probably be the result. Instability would be caused by the long path between the high tension supply and the anode of the power valve and loss of high notes would partly be due to the by-passing effect of the capacity formed by the two leads and earth. The use of a suitable output circuit will divert the direct current of the anode supply of the power valve from the loud-speaker wiring, and only the induced current will be carried along the extension wire. Either a transformer or choke capacity filter output may be fitted as shown in Figs. 31 and 32. In the choke filter arrangement

skirting board, or the floor, and held in position with insulated staples. The loud-speaker leads are connected to the two terminals on the "jack" plug so that the instrument can be plugged in wherever required. The "jack" sockets can be obtained mounted in a box ready for screwing direct to the skirting board or fixing to the wall.

As there is no direct current flowing through the circuit, the positive and negative terminals of the loudspeaker can be disregarded. As many loud-speakers as the set will operate can be used at the same time.

**Remote Control.**

The great disadvantage of the method

just described is the inconvenience of having to get up and go to another room to switch the set off when the programme is ended. It is possible, however, to employ a system of remote control as shown in Fig. 30, so that when the loud-speaker is disconnected the set is automatic-

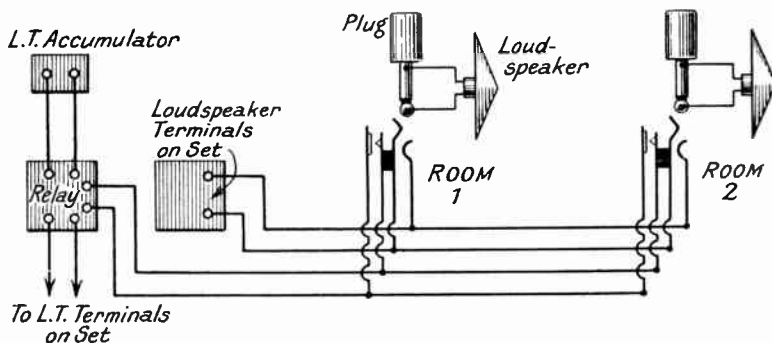

Fig. 30.—REMOTE CONTROL CIRCUIT FOR SWITCHING OFF SET FROM LOUD-SPEAKER PLUG.

the choke should have a value not less than 20 hys. at the anode current passed by the power valve. The condenser can be either 2 or 4 mfd. with an adequate working voltage to guard against breakdown. If the transformer method is preferred, the multi-ratio type should be chosen so that correct matching may be carried out by an aural test, the different ratios being tried in turn until the best quality reproduction is obtained.

**A Simple Extension System.**

The simplest method of wiring a house so that the loud-speaker can be used in any room is that shown in Fig. 35, "jacks" being used. Bell wire, or preferably, the twin flex used for electric-light wiring can be used and the wire carried from one room to another along the picture rail,

ally turned off. In a battery-operated set, switching is usually a matter of disconnecting one of the low-tension leads by means of a simple panel make and break device. A relay will do this as it is quite impracticable to extend the low-tension leads all over the house. Suitable relays can easily be obtained. Four-strand wire should be used for connecting to the set. (See page 98 for particulars of the design and construction of suitable relays).

Remote control switching is rather different with an all-mains receiver and the relay must be actuated with a dry cell.

**FINAL OPERATIONS.**

When a dealer has installed a set he should make sure that his customer understands how to tune it properly.

▲

Many people fail to obtain the best results with their sets because they just move the tuning dials about without attempting to follow any definite plan. The enterprising dealer who wants to obtain a reputation for doing his job properly should advise his customer to make a calibration chart. A calibration chart enables anyone to find in a minute the correct position on the tuning dial for any station that is within the range of the set. It will also enable any station that is heard, to be quickly identified.

### How to Make a Calibration Chart.

A sheet of graph paper ruled off in tenths, a pencil and a ruler, and a copy of *World Radio* are the only materials required.

Prepare the graph paper by drawing two lines from near the left-hand corner, one horizontal and one perpendicular, as shown in Fig. 34. The horizontal line represents wavelengths in metres from 200 to 550, and the perpendicular line corresponds to the dial of the set, from 0-100 or 0-180 according to the type of dial.

The chart is now worked out as follows :

(1) Tune in to a local station which can be easily identified. Your first station might be London National, which might come in at, say, 31 degrees on the dial.

(2) Make a mark at the 31 division on the perpendicular line.

(3) Now refer to *World Radio*, from which you will find that the wavelength of London National is 261 metres.

(4) Make a mark at the 261 division on the horizontal line.

(5) Now draw a line across the paper from the 31 mark, and up the paper from the 261 mark and at the point where these two lines meet make a dot. This is clearly indicated by the dotted lines shown in Fig. 34. If graph paper is used there is no need actually to draw the horizontal

and vertical lines. They can be traced along with the finger.

You will now have obtained the first dot for your chart. You now tune in to three or four other stations which you can easily identify, and, proceeding as above, obtain further dots on the chart. Suitable stations for these first dots are those indicated by the remaining dotted lines shown in Fig. 34.

The next thing is to draw a line joining up the four dots and if you have followed out the instructions correctly this should be either practically a straight line or else a curve, according to the condensers used in the set.

### How to Use the Chart.

Let us assume that you have heard a station with your dial reading at 122, and which you wish to identify. Place a ruler across the paper along the 122 division on the perpendicular line and make a mark at the point where it crosses the line you have previously obtained. Draw a line from this mark straight down to the horizontal line. This will give you the approximate wavelength of the station you are receiving, and it can then easily be identified by referring to the list of stations in *World Radio*.

When it is desired to hear a station whose wavelength you already know, the procedure described above is reversed and the approximate dial reading for that station is obtained. Provided the set is powerful enough, it is only necessary to adjust the dial to that reading to hear the station.

### When Two Tuning Dials are Used.

If the set employs two tuning dials, the chart is worked out according to the readings obtained on the *aerial tuning dial* when the set is tuned in to its loudest.

# MAINTENANCE OF AN ELECTRICALLY EQUIPPED RAILWAY STATION

By H. W. JOHNSON

THE introduction of electric lighting and power into railway working has been attended with remarkable success and efficiency.

Electrically operated points and signals have minimised the possibility of accidents to the travelling public, and have accelerated the passage of trains into large railway stations and through intricate junctions en route.

Passenger stations are well and efficiently illuminated, and destination and indicator boards on platforms are clearly lighted. Luggage is expeditiously moved with electrically driven trucks and lifts.

Station refreshment rooms, restaurants and kiosks are pleasantly lit with decorative fittings and the general atmosphere of waiting rooms is considerably improved with electric lighting and heating.

Electrically driven travelling gantry and jib cranes have contributed to the rapid handling of materials at goods stations. Goods warehouses and sheds are equipped with electrically operated hoists and cranes.

Goods yards and platforms are well lit, giving the maximum of safety and efficiency in loading and unloading goods from wagons. Electrically driven capstans deal with the movement of wagons about the yards quickly and efficiently.

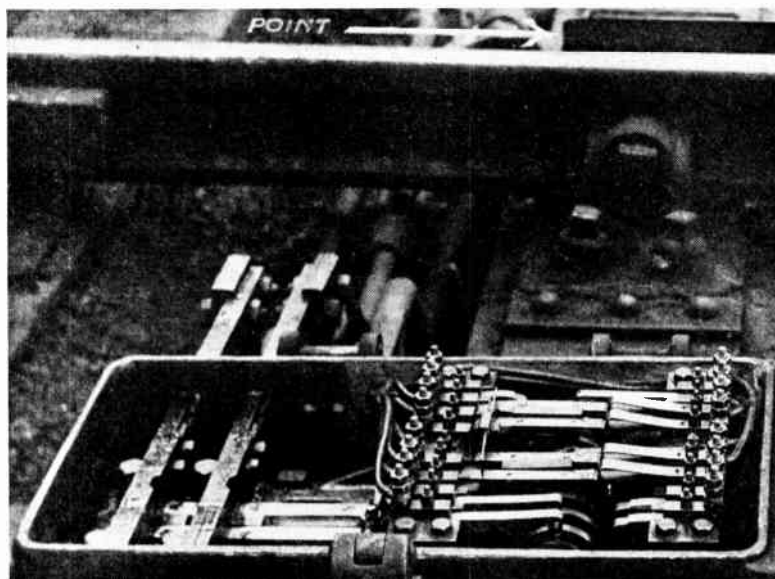

Fig. 1.—POINT MACHINE DRIVEN BY AN ELECTRIC MOTOR.

The outer sets of contacts on the machine are connected in the motor circuit, and their respective positions determine the direction of rotation of the motor, causing the point blade to move from the "normal" to the "reverse" position, or *vice versa*. The inner set of contacts are connected in the detector circuit. The position of these contacts is determined by the position of the point blade. A polarised relay fixed in the signal cabin is energised by the detector circuit.

## The Equipment of Goods Depots.

Within recent years railway companies have spent large sums of money in modernising goods depots, and installing in them up-to-date electrical appliances.

The G.W. Railway Company's goods depots at Paddington, Bristol, South Lambeth, Cardiff, and other large centres,

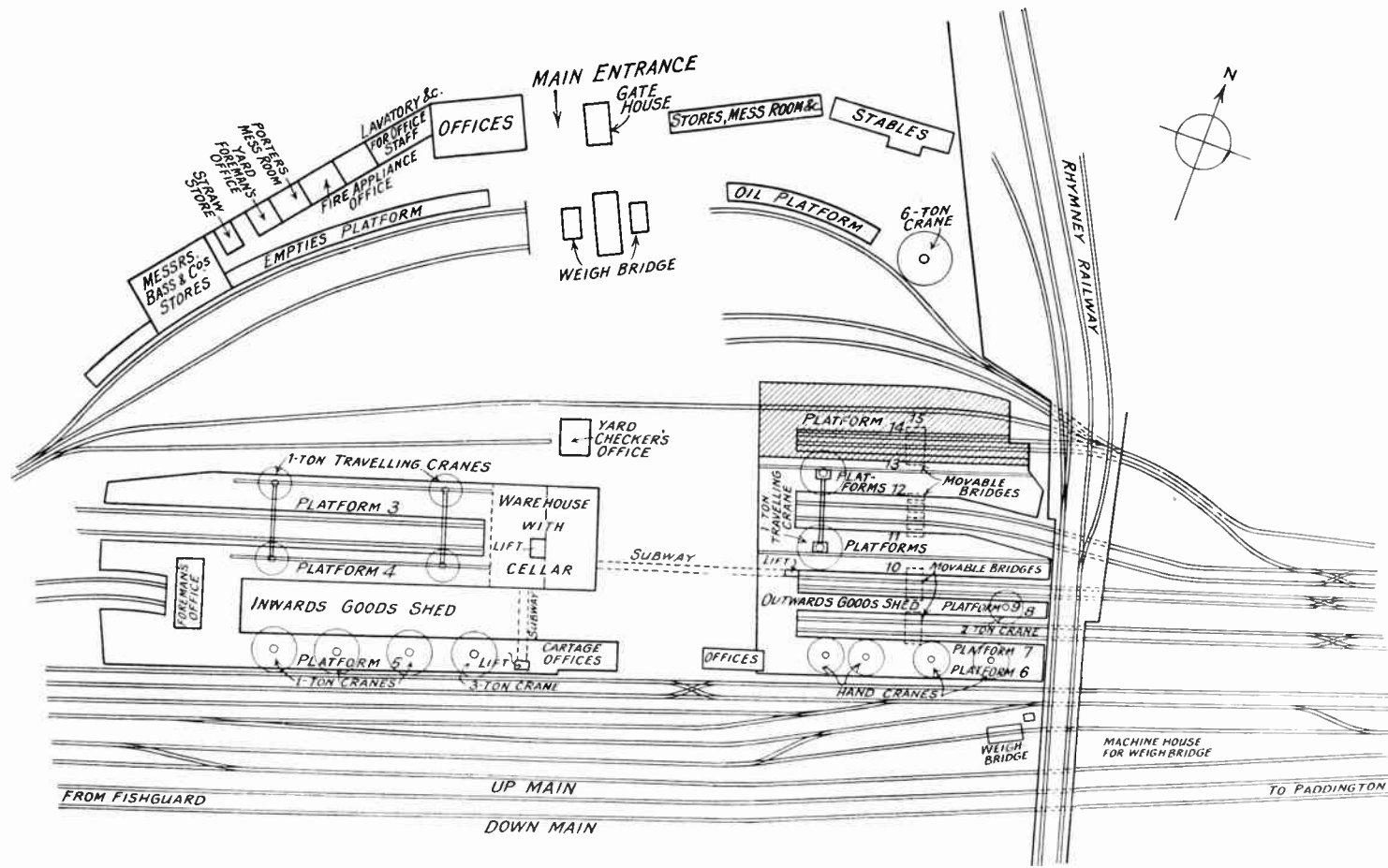

Fig. 2. - The LAYOUT OF THE GOODS DEPOT OF THE GREAT WESTERN RAILWAY COMPANY AT CARDIFF. This is a good example of an efficiently electrically equipped and operated depot.

are notable examples of electrically equipped and operated depots.

A goods depot consists of the goods station and platforms, the goods yard with railway and road communication, storage sheds and warehouses, garage and stable accommodation, and the offices and stores.

### The Goods Station and Platforms.

A number of mobile cranes will be installed; these will be able to operate in any part of the station.

These will be operated and driven electrically.

Electric lifts operated with push buttons will be installed on the platforms, to communicate with basement warehouses. Overhead travelling cranes will be installed; these will span the whole of the platforms and will be able to deal with heavy goods and machinery.

The various operations of lowering, slewing, cross traversing, and longitudinal travelling can be effected as desired; each

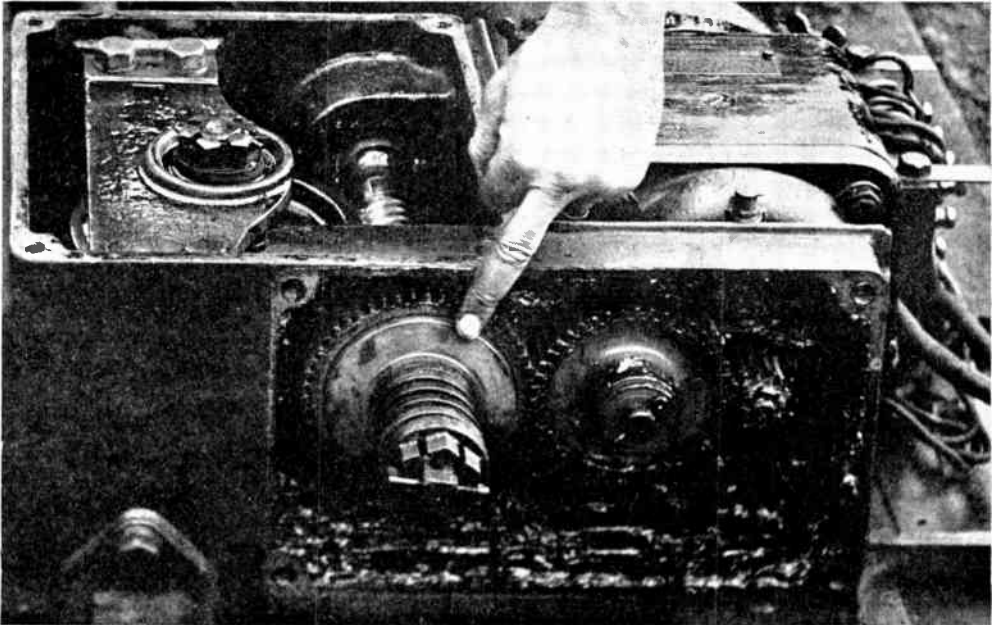

*Fig. 3.—THE GEARING OF A POINT MACHINE.*

The point operating locking bars which move the point blades are geared up to the motor, through a rack and a train of wheels. A clutch is fitted on the last wheel. The clutch disengages the train of wheels from the rack movement when the points are fouled with dirt or grit. The motor is thus protected from damage.

Each crane will be fitted with a petrol electric generating set, consisting of a petrol engine direct coupled to a D.C. dynamo. The dynamo will generate the necessary current for the crane motors, of which there will be four—one for hoisting, one for derricking, and two for travelling. The motors will be operated from the cabin with suitable controllers.

An important feature will be the lifting bridges which span over the tracks and give communication between platforms.

operation is performed by a separate motor.

In order to obviate any risk due to the crane driver's momentary forgetfulness, the hoisting motor is fitted with gear which cuts off the current to the motor when the lifting hook reaches a certain height. A similar precaution is taken on the cross traversing motor, which is stopped when the crane approaches either end of the cross girders. A solenoid brake will be fitted to the hoisting motor

and will come into operation when the current to this motor fails.

### The Goods Yard.

Electrically driven capstans will be used for moving wagons about the yard. These may be controlled with pedals or levers which close the starting switches to the driving motors, and in some cases connect the driving gears to the capstan head. Overload release trips fitted to the switch-gear will cut off the current to the motors when overloaded. The motors may be D.C. or 3-phase A.C., depending upon the nature of the supply.

will be operated with push-button control.

### The Offices.

These will be fitted with suitable electrically operated lifts, and the machines used for adding and abstracting will be driven by electric motors. Electric heating will be installed, and a complete system of intercommunication telephones to the various parts of the depot will be in operation.

### The Lighting Equipment.

Generally, high C.P. gas-filled lamps placed in suitable fittings will be used



*Fig. 4.*—THE POINT MACHINE AND DETECTOR MECHANISM.

The detector contacts are removed. A separate detector is fitted in the 4-ft. way.

Travelling gantry cranes will be installed for dealing with the unloading of trucks in sidings, and mobile petrol electric trucks will operate about the yard.

The gantry crane may be capable of lifting loads up to 40 tons or even more. The supply to the crane motors will be given through a system of live rails, or a trolley system may be used.

### The Warehouses and Sheds.

Electrically driven jib cranes will be used to transfer goods from the wagons or waiting drays on adjacent roadways. Electric lifts and hoists will serve the various floors of the warehouse and they

for lighting the sheds, warehouses, the goods station and yards.

Interior lighting will be effected with open-type fittings having dispersive reflectors, in order to give a good uniform illumination. Current to the lighting fittings will be given through a system of overhead V.I.R. cables, bound to porcelain bobbin insulators. The insulators are fixed to suitable brackets, fitted to the constructional steel work of the roofs of the goods stations and sheds, the cleat type insulators being used to hold the cables on wall and ceiling runs.

Watertight lantern fittings will be used to illuminate goods yards and sidings.



These will be supported from the arms of lamp posts, and from wall brackets fixed to the outer walls of the goods station and warehouses.

Current to these fittings will be given through a system of cab-tyre cables suspended from span wires, the span wires being strained from one post to the next.

The offices will be lit with semi-indirect lighting fittings suspended by chains from the ceilings, and local lighting will be obtained with desk fittings. The wiring for the office lighting will be run in steel conduit.

Flame-proof fittings will be used to illuminate garages and stables. Cab-tyre wiring is advisable in the stables owing to the prevalence of alkaline fumes.

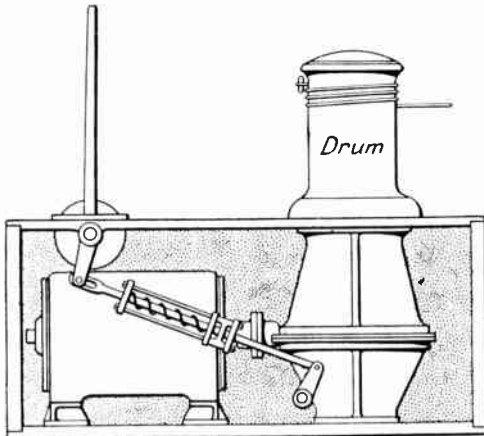

Fig. 6.—LEVER CONTROL OF A CAPSTAN MOTOR-STARTING SWITCH AND CAPSTAN HEAD CLUTCH.

The lever in the backward position releases the capstan head by throwing out the clutch, and in the other direction puts in the clutch and operates the starting switch.



Fig. 5.—THE CABLE DUCTS.

The cables of track circuits, detector circuits and point machine circuits are run from the signal boxes through fibre ducts under the 4-ft. ways, and in wooden troughing along the track, to their respective points.

### Passenger Station Equipment.

An important innovation is the use of electrically driven and operated luggage trolleys on platforms.

They are equipped with a battery of Edison type heavy discharge accumulators which supply current to a series-wound D.C. motor of 2 h.p. The motor is geared to the wheels of the trolley. The motor is operated with a controller fixed on the front of the trolley. Electric lifts serve to communicate the platforms to the subways and overhead luggage runways. These will be operated with push-button control.

At the Victoria Station, Manchester, of the L.M.S. Railway Company, an electrically driven luggage carrier is used to distribute luggage and parcels to the various platforms. The carrier runs on a system of rails suspended from the roof. The current to the motor is supplied through a pair of bare wires, which are fixed directly underneath the rails, but insulated from them. Two current collectors make a wheel contact on the bare wires, and feed the current to the motor. The motor is operated by an attendant who sits in a leather cradle suspended from the carrier.

Station platforms and booking halls

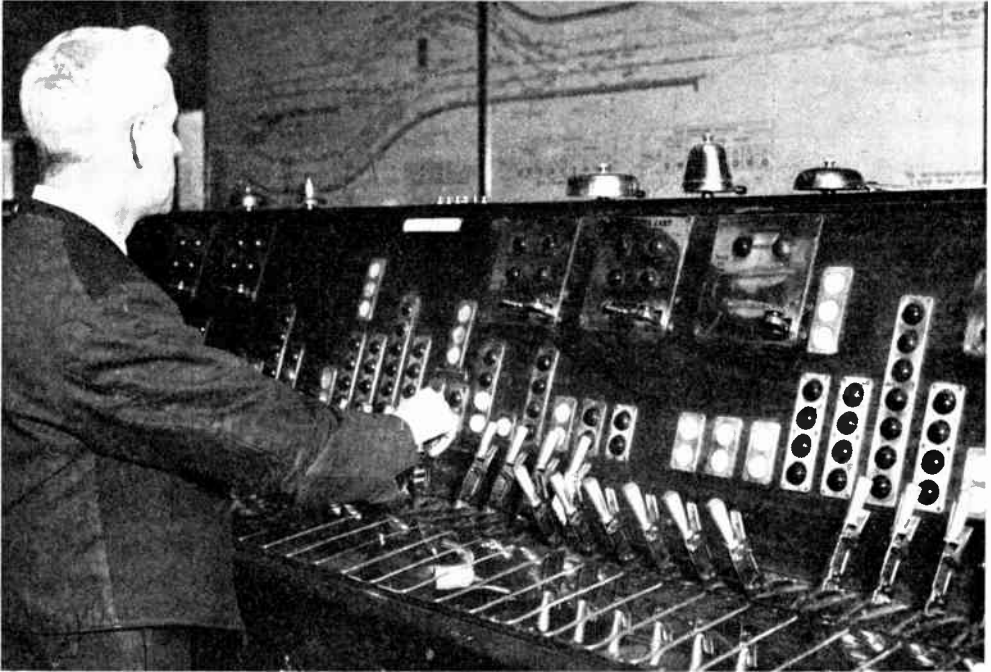

Fig. 7.—THE OPERATING LEVERS OF THE POWER INTERLOCKING FRAME IN THE SIGNAL CABIN.

The signalman observes the state of the illuminated traffic diagram, and operates his signal levers accordingly. The states of the signal aspects are indicated on the signal lamps fitted in the name plates over the levers.

are lighted with high C.P. gas-filled lighting units fitted with dispersive type reflectors. The fittings are supported by chains and stranded steel cables from the roof of the station. Non-corrosive cab-tyre cables bound to bobbin-type cleats, and run along the steel work of the roof, supply current to the fittings, also to the platform number fittings which are fixed at the platform barriers.

Special flood-lighting units are used to illuminate destination and arrival indicator boards. In the restaurants

and refreshment rooms fittings to harmonise with the interior decorations are installed.

#### Electrically Operated Points and Signals.

A system of electrically controlled and

operated points and signals was installed by the Westinghouse and Saxby Signal Company at the Victoria and Exchange stations, Manchester, for the L.M.S. Railway Company. This system is described with the permission of the railway company and facilities have been kindly given for obtain-

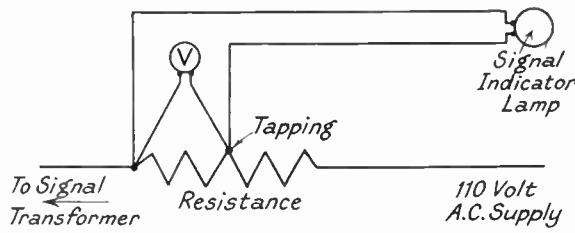

Fig. 8.—TESTING THE PRESSURE DROP ACROSS A SIGNAL INDICATION RESISTANCE.

A voltmeter with a range of 20 volts is connected across the connections of the signal indicator lamp at the resistance. The reading should be from 12 to 14 volts. If the reading is low, and the signal transformer circuit is correct, alter the position of the tapping to give an increased pressure drop until the correct value is obtained.

ing photographs and information by the Signal and Telegraph Engineer and his staff.

### Route Indicators.

These are of the optical type. Each number or letter required is projected on to a glass screen, and the indication is given by an illuminated image on a glass screen. The indicators are fitted with one transformer and one lamp unit for each route required. The lamps used to indicate the route letters are 12 volts 48 watts, and the primary current to the transformers is at 110 volts A.C.

### The Signals.

The main line signals are of three types, namely, four, three, and two aspect. The aspect lenses are illuminated with double-filament lamps taking 12 watts per filament at 6 volts. Each aspect is fitted with a transformer, which transforms the current supplied to the primary winding at 110 volts A.C.

In addition to main line signals, two and three aspect signals are in use at sidings, and for shunting operations.

The range of the signals under average conditions of sunlight is from 2,500 to 5,000 ft. There are some 200 of these signals in use.

The aspects of main line signals are:—

	Red.	Danger.	Stop.
Four aspect	One yellow.	Caution.	Be prepared to find next signal at danger.
	Two yellows.	Warning.	Be prepared to find next signal at caution.
Three aspect :	Green.	All right.	Proceed.
Two aspect :	Red.	One yellow.	Two yellows.
	Red.	One yellow.	

### Indication of Signal Aspects in Signal Boxes.

The indication is carried out by means of the voltage drop across a small resistance, the latter being in series with the primary winding of the signal aspect

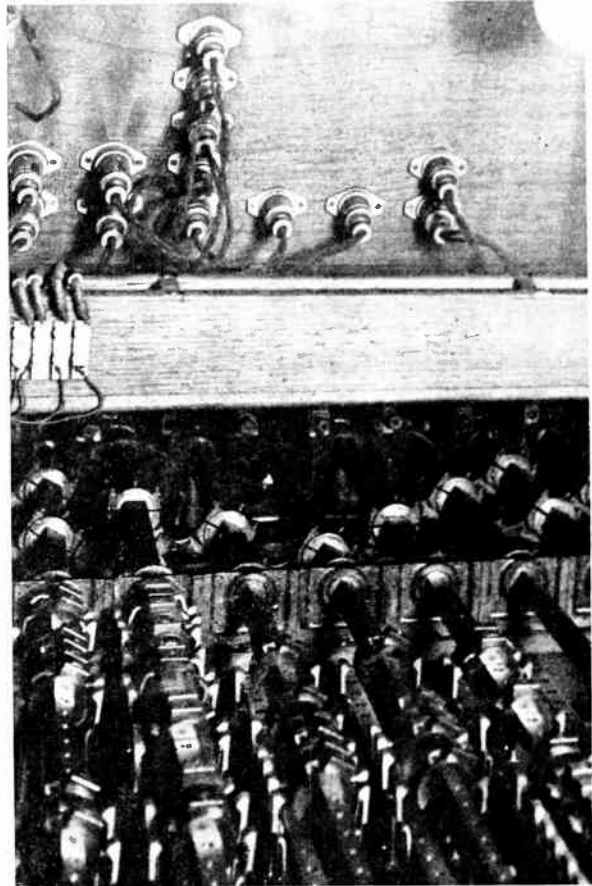

Fig. 9.—THE INTERIOR OF THE POWER INTERLOCKING FRAME.

All the parts are easy of access, and adjustments can quickly be made.

transformers. The drop in voltage is utilised to illuminate a lamp in the signal indicators, which are fitted in the name-plates over the levers. If one of the filaments of the signal aspect lamps fails, the pressure drop across the resistance is reduced, resulting in a big reduction of light in the indication lamp. When both filaments fail, the pressure drop across the resistance is so small that the indication lamp is extinguished. The danger aspect of each signal is indicated by a small red indication lamp, whilst the two yellows and the green are common to the number of signals controlled.

### Illuminated Diagrams.

Illuminated diagrams of the area under control are fixed in important signal boxes. These diagrams are of the strip-light type, and are illuminated with 3-watt 12/14-volt lamps. Also shown on the diagram are "Train ready to start" and "Vehicle

indication, the closing of a switch on the platform lights another lamp on the diagram. This is necessary; owing to the sanding of the rails, or inefficiently bonded vehicles, the track relay may not have been shunted, thus giving a track-clear indication on the diagram.

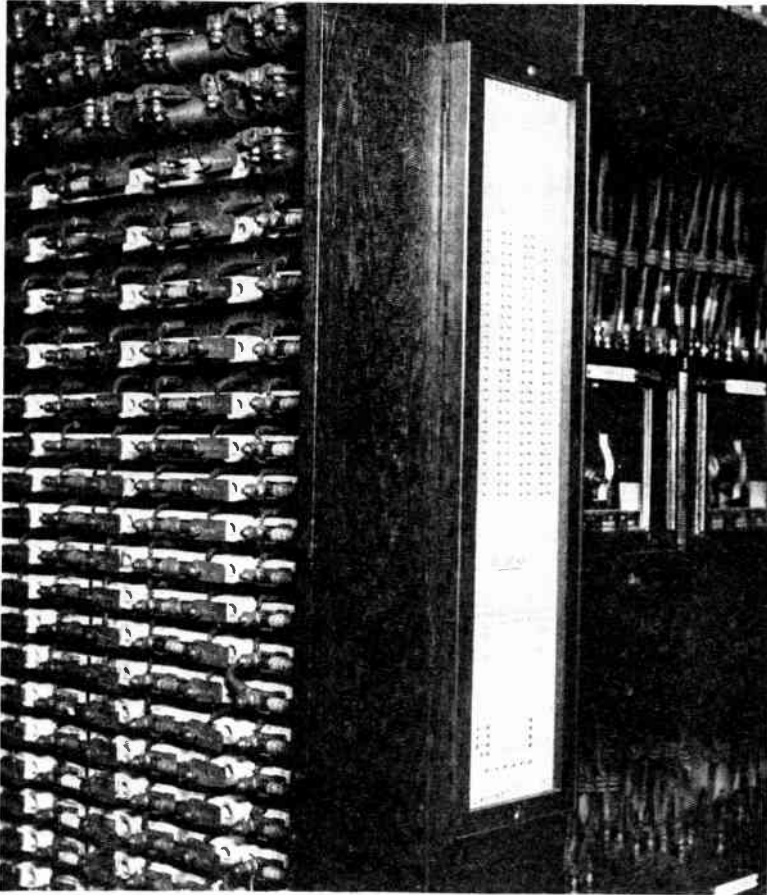

Fig. 10.—THE CIRCUIT FUSES, SIGNAL INDICATOR RESISTANCES AND TRACK RELAYS.

These are situated in the signal box. All circuits are fused up, and are arranged to be easily inspected. The signal indication resistances are fixed above the fuses, and the tapplings may be adjusted when required. The track circuit relays are fixed on racks. The relays are inside dustproof glass cases.

on line" indications. For the former, the closing of a switch on the station platform lights a lamp in the diagram, indicating to the signalman that a train is ready to start from that particular platform. Regarding the "Vehicle on line"

event of an obstruction getting into the points. Each point blade is electrically detected. The detector circuits are designed for use with an A.C. polarised indication relay. The system provides for the energisation of the

### Power Interlocking Frames.

These are fixed in the signal cabins and operated by the signal levers. The frames are fitted in a teak case, having panels which may easily be removed for inspection of the mechanism and making any necessary adjustments.

### The Point Machines.

Each machine comprises a D.C. 110-volt motor taking 3.5 amperes against a load of 200 lbs., clutch, gear train, and a cam arrangement to give a fixed stroke to the point - operating locking bars, all of which are housed in an iron case.

The clutch prevents the possibility of damage to the motor in the

relay in one direction when the points are normal, and in the opposite direction when the points are in the reverse position. During mid-stroke the connecting wires to the relay are short-circuited.

There are 128 point machines in operation.

### Track Circuits.

The track circuits are of the A.C. condenser-fed type, the condensers through which the current is supplied to the circuits varying in capacity from 10 to 40 microfarads.

The pressure of the current at the feed end of the circuit is approximately 1.5 volts. The track relays are of the double-element vane type. These relays can be 100 per cent. over-energised continuously without damaging the contact springs. The relays are housed, with a few exceptions, in the signal boxes. The track circuit transformers have five secondary windings, each secondary winding feeding a track circuit. All track transformers and condensers are housed in the signal boxes. Macanite wiring is used for the track circuits.

### Rectifiers.

Westinghouse metal rectifiers are used for converting the A.C. current to D.C. for the operation of the point machines.

Each rectifier is provided with necessary switchgear and ammeter.

### Block Control.

Block working is used throughout the area covered by the colour-light signals.

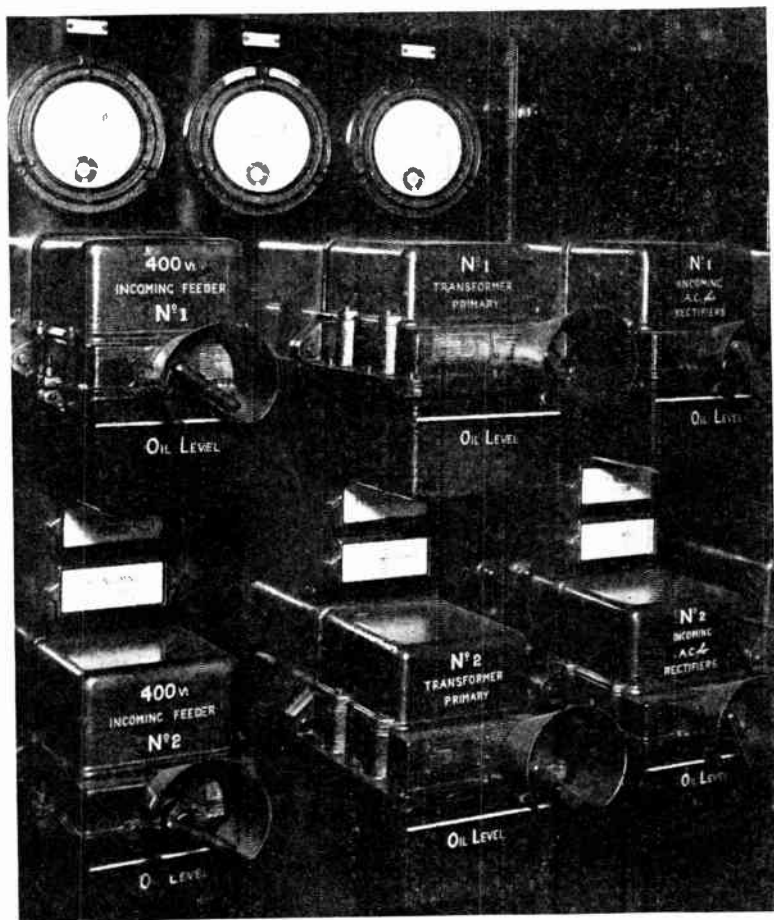

Fig. 11.—THE RECTIFIER SWITCHBOARD.

The rectifiers which supply current to the D.C. point machine motors are fixed in the signal box. They are controlled with switches, and the load is indicated on the ammeters. Two A.C. feeders from the automatic substation feed the switchboard.

The block instruments are of special design and indications are given by coloured lights, red indicating "Train on line," green "Line clear," no lights indicating "Line blocked." The circuits are so arranged that before "Line clear" can be given for a second train, the commutator on the power inter-

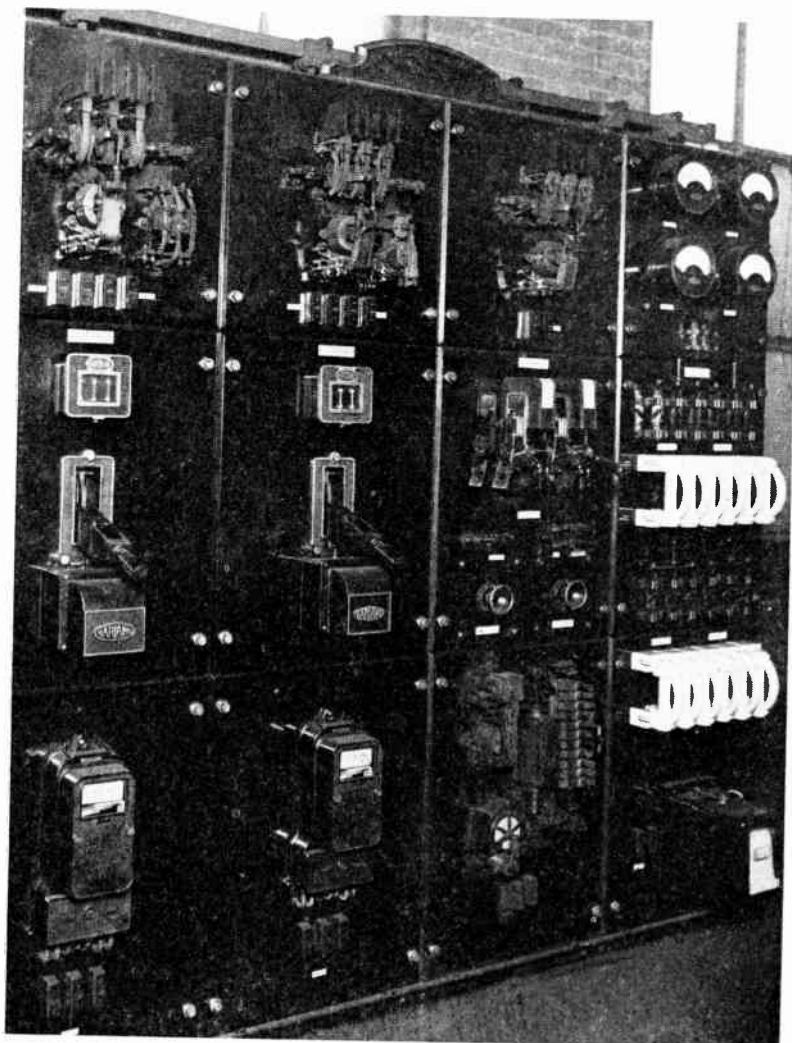

Fig. 12.—THE AUTOMATIC SUBSTATION SWITCHBOARD.

The switchboard is supplied with A.C. from the Salford Corporation Electricity Department mains and D.C. from the Manchester Corporation Electricity Department mains. The normal supply is from Salford. In case of failure the load is automatically thrown on to the Manchester supply, which is D.C. As a supply of A.C. is required for all circuits except the point mains, a three-phase motor alternator starts up under the influence of the solenoid control when the change over takes effect.

locking frame must be turned to the "Train on line" position. The last stop signals for boxes in the rear are controlled by the block instruments.

Should the signalman pull the signal lever before the "Line clear" has been given, the H.R. relay controlling the signal

cannot be energised. This relay, once energised, cuts out the block control, thus allowing the block to be turned from the "Line clear" to "Train on line" position, without putting the signal to danger. Should the signalman omit to put the block instrument to the "Train on line" position, this is done automatically when the vehicle arrives on the track circuit in advance of signal.

When a train enters upon the track circuit in advance of the last stop signal in the rear, the stick relay controlling this signal is de-energised, and before the H.R. relay controlling the signal can again be energised, "Line clear" signal must again be given on the block instrument, thereby compelling the signalman to obtain "Line clear" for each train entering the section.

#### Power Supply.

Two 3-phase 4-wire supplies are obtained from two separate substations of the Salford Corporation and fed into the railway automatic substation at a pressure

of 400 volts. A third supply at 400 volts D.C. is brought from the Manchester Corporation mains to this substation.

The switching gear is so arranged that in case of failure of No. 1 supply from Salford Corporation, the bus bars feeding the signalling system are automatically switched on to No. 2 supply. Should there be an entire failure of the Salford Corporation supply, a 25 K.V.A. 3-phase motor alternator is automatically switched on to the Manchester Corporation mains, which start the D.C. motor, and the signalling supply is obtained from the alternator. A time lag relay delays the change over from the Salford Corporation mains to those of the Manchester Corporation for a period of 15 seconds. This is to make allowances for momentary failures of the Salford Corporation supply.

The load of the 3-phase system is arranged to keep an approximate balance of load on all phases. A tapping is also taken from this supply to the bank of metal rectifiers which converts the A.C. current supplied to them to 120 volts D.C., which is required to operate the point-machine motors. The rectifiers are arranged in such a manner that if any particular set of the bank becomes faulty, this set will be cut out and leave the remainder at work.

#### NOTES ON MAINTENANCE.

The staff who attend to the maintenance of the equipment and wiring will consist of two sections. One section, which is under the control of the Chief Electrical Engineer and his executive, will be responsible for the maintenance of electrical appliances and wiring in goods depots and passenger stations. The other section dealing with the maintenance of the signalling and point-operating equipment and wiring will be controlled by the Signal and Telegraph Engineer. The shift system

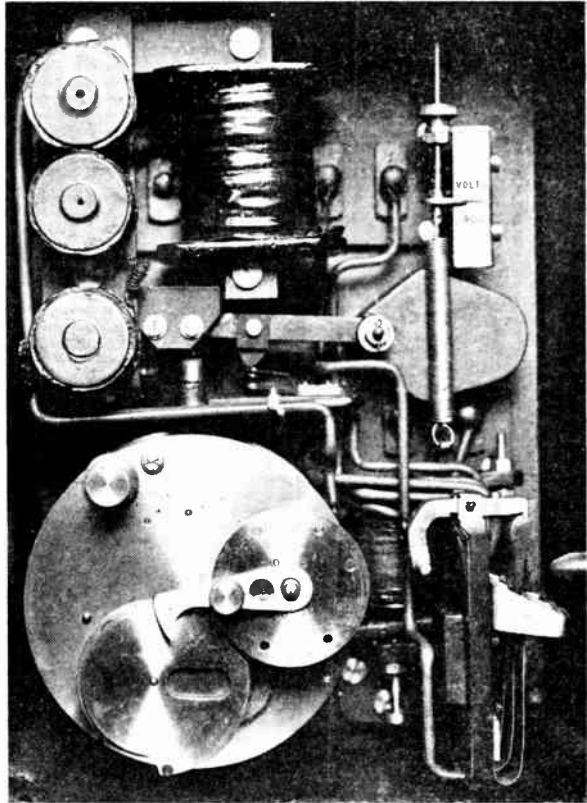

Fig. 13.—THE RELAY IN THE AUTOMATIC SUBSTATION.

This relay delays the change over from Salford to the Manchester supply for 15 seconds.

It operates on the auto-change-over switches. The delay action may be adjusted within limits.

of working will be in use, approximating 8 hours per shift. It is particularly important that there should always be some of the staff on duty to attend to failures and breakdowns.

#### The Lighting Equipment.

Runs of wiring fixed to the constructional steelwork of roofs in passenger and goods stations will be exposed to engine smoke and steam. They should be frequently examined for corrosion and deterioration of the insulating covering. Cleat-fixing screws and bolts should be kept free from rust; a little oil or vaseline smeared on them will prevent rusting. Span wire, cable suspensions, chain and steel cable supports of lighting fittings should be

regularly inspected and renewed when they are defective.

The lampholders and the connections to them in open-type fittings will require frequent inspection for corrosion and bad contacts. The reflectors and lamps should be kept quite clean. The dirt on them may be removed with a weak solution

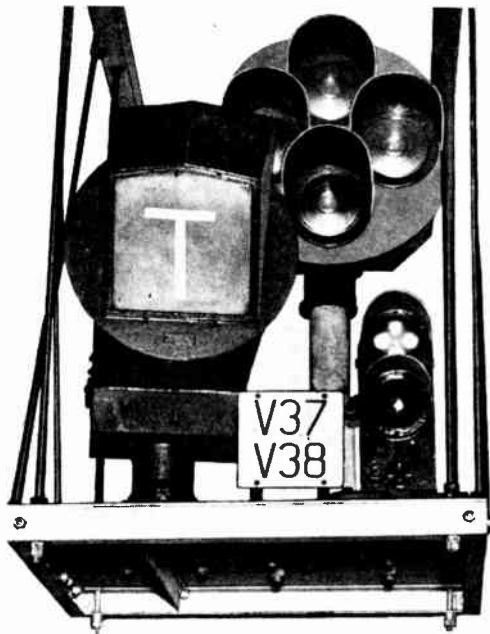

Fig. 14.—A PLATFORM ROUTE INDICATOR AND CALLING-ON SIGNAL.

The route is indicated on a ground glass screen. The circuit feeds a transformer which lights a 12-volt lamp. This lamp illuminates the route letter T, and an image of this letter is projected on a ground glass screen with a convex lens. The calling-on signal is given by projecting the light from 12-volt lamps through coloured convex lenses. The lamps are fed from the secondary windings of transformers. Cowls are fitted over the lenses and ground glass screen to prevent blinding with direct sunlight.

of nitric acid and water, 1 part acid to 100 parts of water. Clean the Edison-screw sleeves and centre contact studs of high C.P. gas-filled lamps with fine glass paper. Examine the fuses in distributing boards and renew any which are defective, adjust the fuse contacts and tighten up any loose connections.

The switches should be regularly inspected, their quick make and break action should be in good order, and the switch blades be clean and make good contact.

Clean the surface of the panels and the porcelain fuse bridges regularly, and note that the joint between the case of the distributing board and the hinged door is watertight. The earth wires to iron-cased distributing boards, iron-cased switches, metal-cased lighting fittings, and conduit runs, must all be in good condition.

#### Platform Trucks.

The accumulators should be regularly inspected and charged. On no account should they be allowed to become over-discharged. All terminal connections should be covered with vaseline. The vent plugs should make an alkaline-proof joint.

Remove all dirt and acid from the outside surfaces of the accumulator containers. The electrolyte, caustic potash solution, should be renewed about once a year. Examine the brush gear and commutator of the motors, renew brushes when necessary and clean all dirt from the brush gear and commutator, tighten up any loose connections at the terminal box of the motor. Examine the gearing and note that there is a good supply of lubrication. Inspect the controller contact fingers, renew any which are defective, and adjust those which are making bad contact with the drum.

#### Lifts and Hoists.

These must have a careful inspection at frequent intervals and the various safety devices examined.

Examine the condition of the steel suspension cables and their attachment to the car and the counterweight.

The car and landing-gate switches should be in good working order and the locking mechanism must prevent the gates being opened unless the car is at the correct level.

The over-travel and over-speed limit switches must operate when the car reaches the limit of its travel, or exceeds the safe speed.

Examine the condition of the push-button controls and the relays. The



contactor starting switches for the motor should be working smoothly; clean any burnt contacts with fine glass paper, and lubricate the armature spindles with a little clock oil.

The solenoid brake should act promptly when the current to the motor is switched off.

Inspect the winding motor regularly and clean the brush gear and commutator. There should be a good supply of lubricating oil in the motor bearings. The gearing should be working smoothly and be efficiently lubricated.

### Mobile Petrol Electric Cranes.

The engine should run smoothly and the lubricating system be in good condition. Examine the sparking plugs frequently, the valve spindles should work freely, inspect the valve facings and seatings, and grind in any which show signs of "pitting." Inspect the condition of the carburettor, and see that the "float" is working. The petrol pipe connections should be in good condition, there should be no leakage of petrol at any of the cocks. Keep the magneto perfectly clean, examine the state of the distributor and brushes. The H.T. cables to the plug terminals should be free from oil and grease.

Examine the condition of the brush gear and commutators of the dynamo and the motors. Inspect the condition of the armature and field magnet windings frequently. Tighten any loose connections in the terminal boxes of the machines.

The bearing bushes should be tested for wear, and the bolts which secure the machines to the frame of the crane should be tight; all nuts on these bolts should be locked.

Clean any burnt contact fingers on the controllers, and adjust them for making good contact. Inspect the condition of the resistance units; keep them free from dirt and oil. Examine the operation of the control levers, clutches, and gearing. The winding cable and its attachment to the crane hook should be in good condi-

tion. Test the brakes for efficient operation.

### Overhead Travelling Cranes.

The insulation of the live rails or conductors which supply the current to the motors must be regularly inspected; examine the bonds for making good connection between rail joints. The fibre insulating bushes and plates must be in good condition and kept dry. Where a system of overhead bare conductors is employed, the strain insulators and their attachments to the live wires must be frequently examined. The trolleys, or current collectors, should make good contact with the wires.

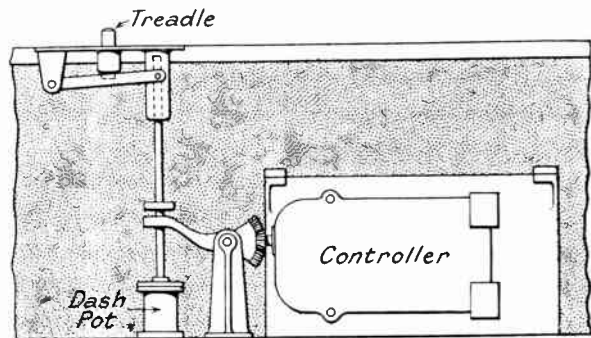

Fig. 15.—TREADLE CONTROL OF A CAPSTAN MOTOR CONTROLLER.

The movement of the treadle is retarded with the dash pot, which prevents undue haste in starting up the motor.

The collector gear in the crane cabins for distributing the current to the motors should be regularly inspected. The brushes should make good contact with the collector rings. The rings and their insulating mountings should be kept free from oil and dirt.

Examine the mechanism which prevents overwinding of the crane hook and overtravelling, and test them for good working order. The solenoid brake on the hoisting motor should act promptly when the current to the motor is switched off. Clean all brush gear and commutators of the motors regularly, and keep the cables free from oil and dirt.

Inspect the condition of the controllers, and renew any contact fingers which are defective. The lubrication of the motor

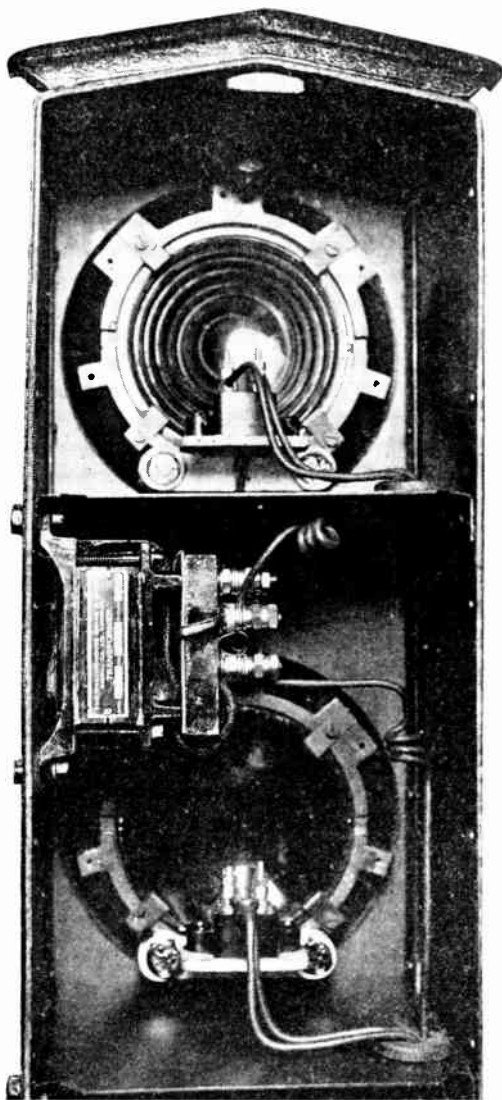

Fig. 16.—THE INTERIOR OF A SIGNAL.

Each of the signal aspects is illuminated with a 6-volt, 24-watt double filament lamp.

The light is projected through 8-inch diameter lenses. Each signal is fitted with a pin hole and cross wire for sighting purposes. The lamps are fed from the secondary windings of transformers, which are fed with 110 volts A.C.

bearings and all gearing should be regularly attended to.

#### Capstans.

Particular attention must be given to

the ventilation and cleanliness of the capstan pits. There is here often a great deal of condensation and collection of moisture which will quickly cause break-downs of the motor armature and magnet windings if it is allowed to remain.

Inspect frequently the condition of the motor brush gear, commutator and windings.

An insulation resistance test of the motor and control switchgear should be made at frequent intervals. If a low test is obtained the motor should be dried out. An electric heater fixed near the motor will assist the process of drying.

The action of the starting treadle or lever should be in good condition; inspect the dashpot which controls the free movement. The contactor switchgear should be kept clean, and all contacts in good order. Inspect the lubrication of the motor bearings and the gearing to the capstan head.

#### The Signalling and Point Equipment Point Machines.

Inspect the condition of the motor brush gear and commutator; the contact fingers of the motor and the detector circuits must be clean and make good contact. Adjust any which are making bad contact, and clean up the contact surfaces with fine glass paper.

Remove any traces of grease or dirt.

Examine the condition of the gearing and note that the lubrication is efficient. Tighten any loose cable connections at the terminal box of the machine.

The runs of wiring from the signal box to the machine should be frequently inspected, and the cable ducts kept clean and dry.

#### Signal Aspects and Route Indicators.

The lenses should be cleaned with a soft dry cloth. Examine the condition of the lamps and renew any which show signs of blackening or have defective filaments. The cable connections to the lamps and transformers should be in good order. Inspect the transformers. The joint between the hinged door and the case of the signal or route indicator should be watertight.

### The Track Circuits.

These should be inspected frequently. The cable connections to the metals must be tight. Any signs of corrosion at the connections must be removed so that a clean contact is obtained. The bonding of the metals must be in good condition. A pressure drop test with a millivoltmeter for efficient bonding should be taken at regular intervals, or when a bad bond is suspected. The track relay cannot function if bondings are defective.

### The Track and Point Circuit Feeds and Fuses.

Examine all connections from the bus bars and tighten any which are loose. The fuses should make good contact in their respective fuse contact holders. Adjust any contacts which do not grip the fuse holders tightly.

The dust should be removed from the fuse board with a vacuum cleaner having an insulated nozzle.

### The Signal Indicator Resistances.

Inspect the connections regularly, and test the pressure drop across any which appear defective, or which fail to cause the indication lamps to light up. The tapping may require adjustment to obtain the correct pressure drop required to light up the indication lamps.

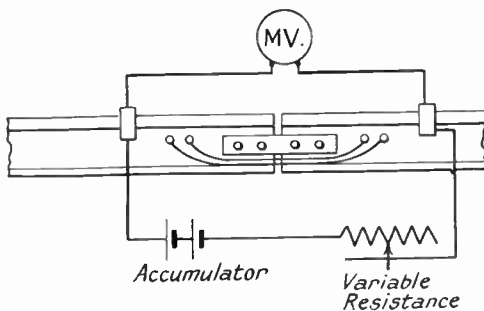

Fig. 18.—TESTING A BONDING CONNECTION.

When a high bonding resistance is suspected, make a pressure drop test across the bond. Send a suitable current through the bond and measure the pressure drop with a millivoltmeter. If the resistance is too high, indicated with a high reading on the voltmeter, remove bonding connection and clean all connecting surfaces and replace with good bonding wire.

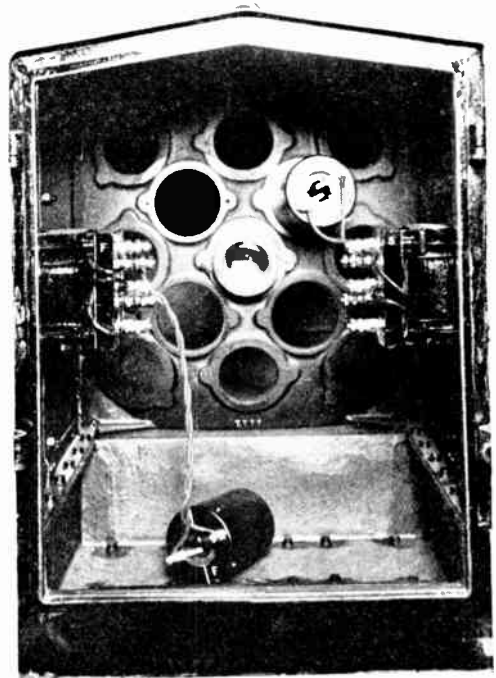

Fig. 17.—THE INTERIOR OF A 13-WAY ROUTE INDICATOR.

Each route letter or number is illuminated with a lamp fed from a transformer. The lamps are 12 volts, 48 watts. The interior is easy of inspection. A watertight joint is made with the case and the back.

All traces of dust should be removed with the vacuum cleaner.

### The Automatic Substation.

Inspect regularly all switchgear, test the tripping gear of switchgear not in commission, clean switch contacts, and lubricate all trip lever spindles.

Examine the condition of the automatic solenoid motor starter and test the action of the solenoid plunger.

Clean the switch panels with a soft, dry cloth. Inspect all cable connections at the back of the switchboard, and remove all dust.

Inspect the working of the change-over time lag relay.

All complaints of any failures to any part of the equipment should be immediately attended to and made good at the earliest moment.

# ERECTING BATTERIES FOR SMALL GENERATING SETS

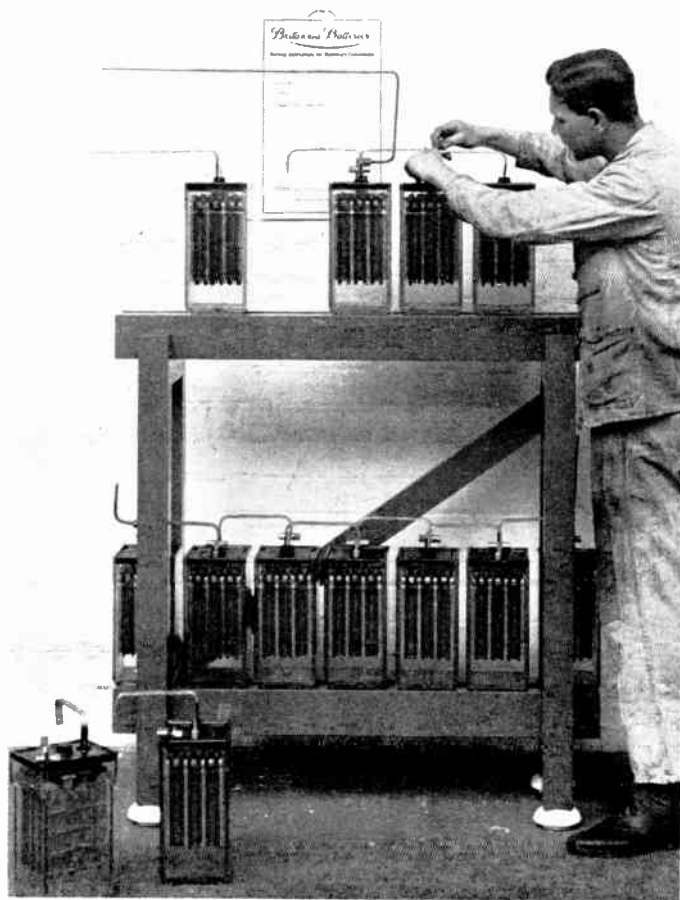

Fig. 1.—THE BATTERIES IN COURSE OF ERECTION,  
(Stuart Turner, Ltd.)

The engineer is bolting up the lugs of adjacent cells, taking care to see that the faces are square so that good contact is made.

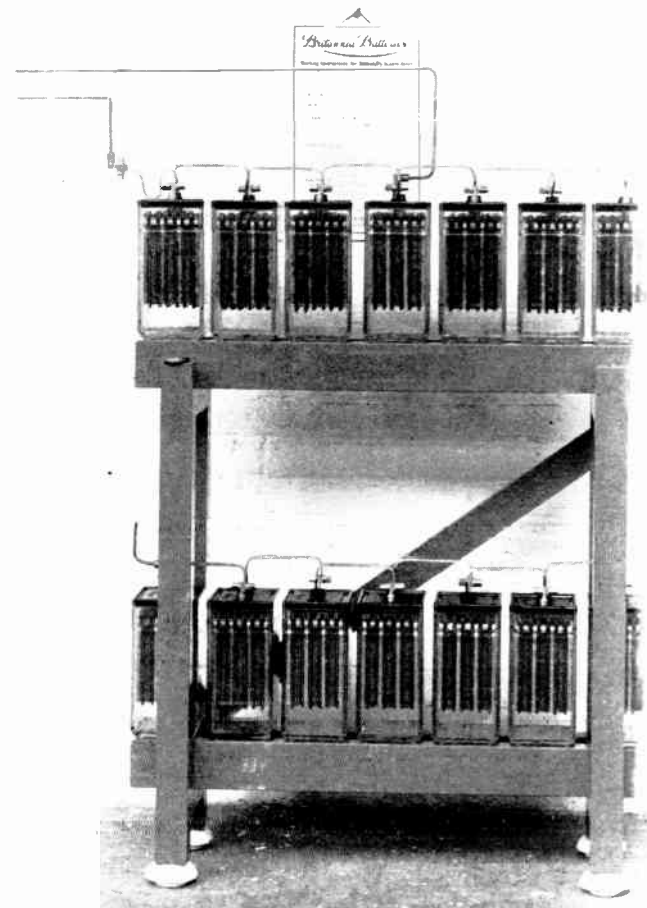

Fig. 2.—THE COMPLETED JOB. (Stuart Turner, Ltd.)

Showing connections for full battery and part battery. The lugs have been covered with vaseline to prevent corrosion.

# MICA

## AND ITS APPLICATIONS IN ELECTRICAL ENGINEERING

By M. G. SAY, Ph.D., M.Sc.



Fig. 1.—RAW MICA AT MINES IN INDIA. (Micanite and Insulators Co., Ltd.)

Mica occurs in the form of so-called "rock." Its formation is such that it can be readily split into sheets of thickness down to less than 1 mil.

ONE of the most valuable mineral insulating materials in present use is mica. Its use for windows and lamp covers has been known for a considerable time and it was already available when its great advantages for electrical insulation were discovered.

Mica is a peculiar substance composed of a chemical combination of silicon, aluminium and potash. It contains also small quantities of metallic ores, which may give it a distinct coloration, such as grey, green, ruby and brown.

### Where Mica Comes From.

Most of the world's supply is mined in India, where it occurs in the form of so-called "rock." Its formation is such that it can be readily split into sheets of thickness down to less than 1 mil. It is impossible, however, to get large sheets of this thickness, as mica is very brittle. Large sheets, being difficult to mine,

bear a high price, and are not used unless the particular application so demands. Much attention has, therefore, been given in recent years to the electrical use of mica "splittings," which are comparatively cheap. Splittings may be stuck together with shellac varnish, or backed with paper or cloth. Alternatively, splittings may be powdered and used as a filler for synthetic-resin mouldings. Mica sheets without backing or adhesives are known as "virgin mica," and are used for small commutator sectors, condensers, sparking plugs and insulating washers. These uses, however, are not extensive, and by far the greater proportion of mica is used in its manufactured forms.

### Properties of Mica.

The qualities of mica are very valuable to the electrical engineer. The fact that it can be readily split into thin sheets enables any required thickness to be

obtained. It has a high dielectric strength and ohmic resistance, withstands high temperatures without change, and will support large compressive (squeezing) loads. These two latter properties are the results of its natural formation at high temperature and pressure in the earth's crust. Mica is slightly flexible, but cannot—in its virgin form—be bent; for this it has to be used in a manufactured form.

### Why Mica is so Useful.

Those called upon to repair an electric kettle or flat-iron will be familiar with

The mica serves to insulate the heater element from surrounding metal, and at the same time conducts the generated heat to the surface at which it is required. The three characteristics of insulating quality, resistance to high temperatures, and great compressive strength are thus fully utilised.

An inspection of the kettle or flat-iron will usually reveal a further use for mica. The socket pins may be bushed with mica—again on account of the mechanical and thermal qualities.

### Mica for Motor Insulation.

Small D.C. motors sometimes have

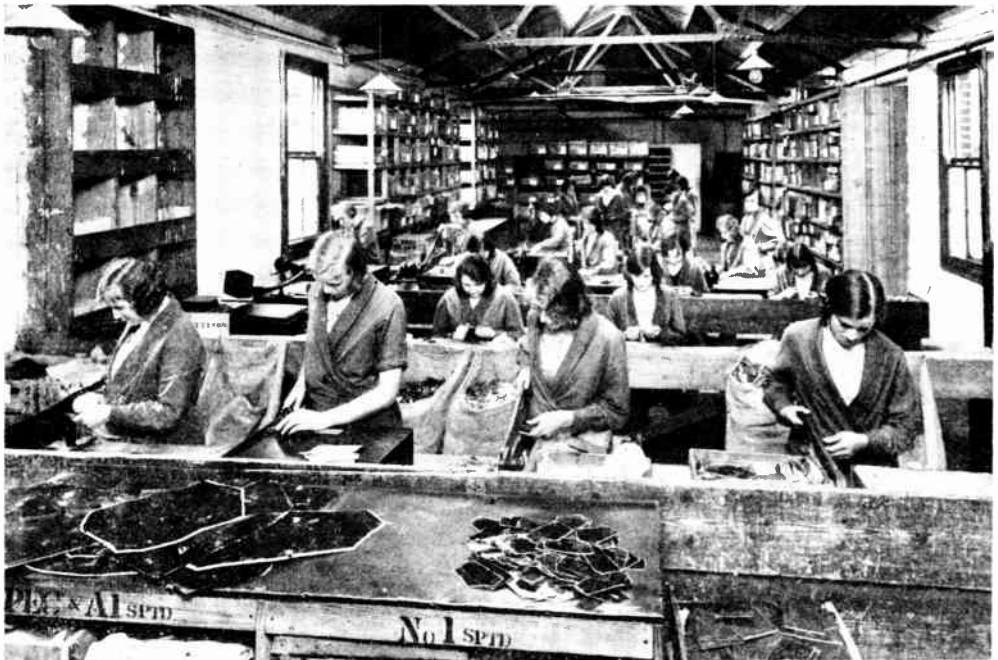

Fig. 2.—A TYPICAL WORKSHOP FOR THE PREPARATION AND MACHINING OF MICA. (*Micanite and Insulators Co., Ltd.*)

This shows the mica being cut into sheets, the edges being retained for use as "splittings."

the properties and appearance of virgin mica. It may be said that this peculiar mineral has rendered possible the cheap manufacture of domestic electrical goods involving the production and use of heat. Virgin mica and micanite (*see later*) of suitable shape are used to carry the thin high-resistance metal strip winding of the heater, which is pressed into intimate contact with the metal surface to be heated (e.g., the false bottom of a kettle).

commutator sectors insulated with mica sheet, where the commutator does not exceed about  $\frac{1}{4}$  inches in length. The advantage here is that adequate insulation between the sectors can be readily obtained with very thin sheets of mica, thus saving space; also, the mica is strong enough to withstand the compression. Being sometimes harder than copper, however, the mica may wear less rapidly as the commutator revolves

under the brushes. Since "high micas," or projecting mica sheets between the copper sectors, are a cause of sparking, it is common practice to "undercut" the micas periodically to  $\frac{1}{16}$ -inch deep. This may be done by hand on a small motor by means of a hack-saw blade, but better work is obtained on large machines by a special device resembling a machine-shop mill.

An important use for virgin mica is in the manufacture of condensers for scientific instruments and for automobile ignition devices. Sheets are split to thickness, micrometer gauged, stamped to shape and assembled.

Mica is not a material easily worked outside a specialised manufactory.

#### **Micanite—A Cheaper Form of Mica.**

Micanite is a very common form of mica product, used where large sheets are desired, and where virgin mica would be prohibitive for reasons of cost. It is made up of mica splittings and some adhesive.

It takes many forms such as sheets, boards, tubes and moulded parts, and may have a variety of qualities such as hard, flexible, moulding and heat-resisting, in accordance with the character of the constituents.

#### **How Hard Micanite is Made.**

Hard micanite is used in place of virgin mica for large commutators. It is generally composed of the smallest grade of splittings with shellac as an adhesive. Since shellac is an organic gum which deteriorates with heat, micanite cannot be used at such high temperatures as virgin mica. To make the material,

splittings are shaken down in a "snow-storm" inside a tower on to a tray at the bottom. When a sufficiently thick layer has been deposited, the tray is sprayed with shellac, and a further layer of splitting deposited. The final process is a hot pressing between steam-heated plates.

Moulding micanite is similar, but contains a greater proportion of shellac, making it possible to bend and shape the sheet when hot. Flexible micanite can be bent when cold; for this purpose a non-drying oil is incorporated with

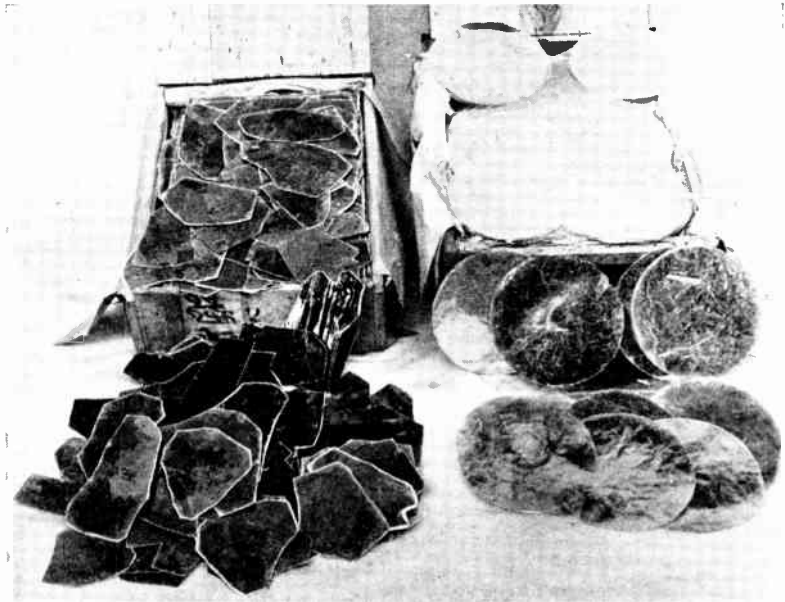

*Fig. 3.—BLOCK MICA AND MICA SPLITTINGS (PAN PACKED) AS RECEIVED FROM THE MINES. (Micanite and Insulators Co., Ltd.)*

the shellac. The material is largely used in the insulation of large high-voltage machines.

#### **Micafolium—Its Form and Uses.**

This material finds particular application to wrapping the conductors of high-voltage electrical machines. It consists roughly speaking of micanite backed with paper, i.e., mica splittings stuck with shellac on to the surface of a suitable paper. Since paper is a poor insulator compared with mica, as great a proportion of mica as possible is used. In a coil wrapping, however, it is scarcely possible



Fig. 4.—ANOTHER VIEW OF THE PREPARATION AND MACHINING OF MICA.  
(Micanite and Insulators Co., Ltd.)

Showing the operators punching mica segments, washers, etc., from sheet mica.

to attain more than one-quarter mica, the rest being paper and adhesive.

### How Micafolium is Applied.

Micafolium is always applied by means of a hot ironing process which is easily performed on straight conductors, bars, etc. The micafolium is first wrapped on hot; the bar is then taken to a wrapping machine, where long heated irons rotate in the direction of winding round the bar, dragging the wrapping tight and causing it to adhere into a compact, uniform "cell" with a smooth surface. The process is a particularly important one and yields excellent results for high-voltage machines. All the air is ironed out and the corners are particularly compact. Thus dangers of air ionisation (which may occur more particularly at sharp points and corners) are obviated.

### Other Uses of Manufactured Mica.

Metal bars carrying contacts from which they must be insulated are commonly required in small and large switchgear. Micanite or micafolium wrap give good service in these conditions. A similar use is the insulation of the contacts from

the dolly in the common domestic tumbler switch.

*Mycalex* is a compound of finely ground mica bonded with glass. It is a comparatively recent product and is in an active state of development. A valuable use is for radio-frequency insulators, since it maintains its insulating properties at these very high frequencies.

*Mica tape*, composed of splittings varnished on to silk or cotton tape, is used for the bent portions of high-voltage machine conductors where the micafolium wrap is not applicable.

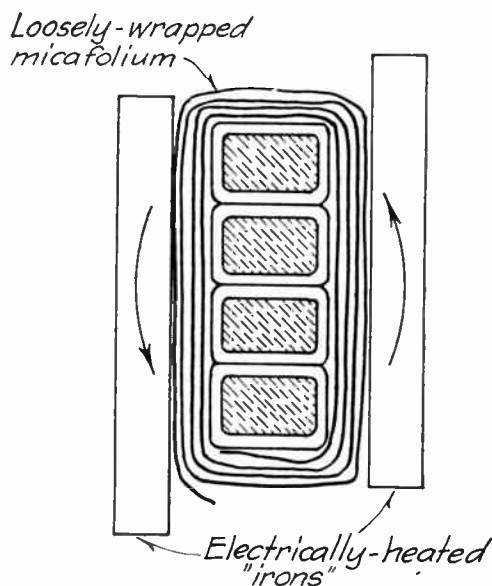

Fig. 5.—HOW MICAFOLIUM IS APPLIED.  
Showing the hot ironing process.



# ILLUMINATION OF SCHOOL BUILDINGS

By E. H. FREEMAN, M.I.E.E.

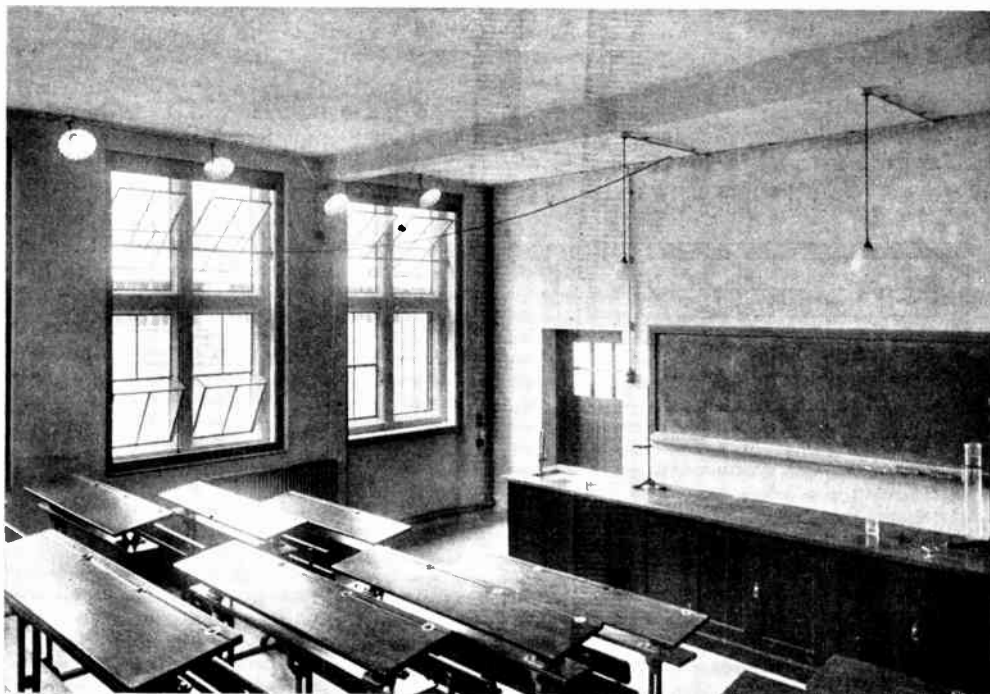

Fig. 1.—SMALL LECTURE ROOM LIT BY SIDE REFLECTORS.

These are arranged so that artificial light is obtained from the same direction for all pupils as the daylight.

**S**CHOOLS, like every other class of building, have their own special problems for the illuminating engineer but most of these problems are easily solved on the general principles that have been dealt with in earlier articles. These must be applied, as usual, with due attention to the special conditions that must arise from the use of each kind of room.

A committee was appointed about two years ago by the Illuminating Engineering Society to consider the special problems connected with school lighting, their recommendations being embodied in a

report published in the *Illuminating Engineer* in July, 1931, and reference is made below to various questions raised in this report.

## CLASS ROOMS.

The most important room in the school for the illuminating engineer is the class room—not as regards its character as a room in any particular school, but because there are so many more class rooms than there are other rooms and because the greater part of the school work is carried out in these rooms.

Adequate lighting is essential and a

standard of eight candle feet should be provided. The report mentioned above gives five foot candles as a minimum but a higher standard than this is certainly desirable. Class rooms are now more or less standardized and Fig. 2 shows a typical room with desk accommodation for 25 pupils, the desks being arranged with the daylight coming from the left of the pupils and with the master's table facing the pupils, with the blackboard behind him.

### General Lighting.

The form of lighting that is more or less standardized for such a room consists of four pendants located as shown in Fig. 2.

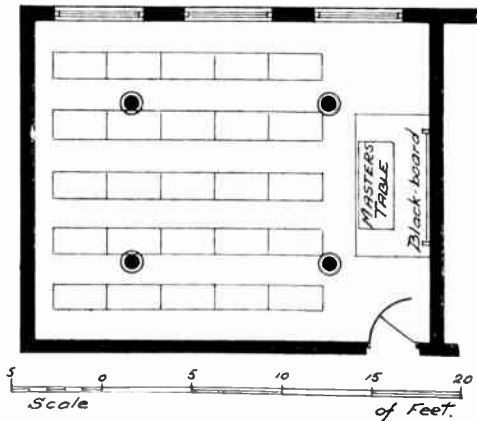

Fig. 2.—LIGHTING FOR SCHOOL CLASS ROOM.

This shows a suitable arrangement when no special light is provided for the master's table.

With the usual proportions of the modern class room this scheme will give very good general lighting. The usual height of such a room is about 10 ft. 6 in., corresponding to a working height of 7 feet and involving a spacing distance of about 10 to 12 feet—these all being in accordance with the principles laid down earlier for either enclosed unit pendants or dispersive reflectors. The actual spacing in the room shown is 11 feet in one direction and 9 feet in the other.

### Nett Lumens Required.

The total area of the room is 18 ft. by

22 ft., or 396 sq. ft., and for eight candle feet the nett lumens required will be about 3,200.

Such rooms as these will certainly be finished with white ceilings and white or very light coloured walls above a darker dado, so that the conditions are favourable in every respect. The fittings used can be of a type giving a high efficiency, each with a single lamp, and an overall efficiency for the entire lighting scheme of 60 per cent. should certainly be obtained.

The gross lumens will thus be about 5 500 lumens and four lamps of 150 watts each will give satisfactory results, each having an output of 1,875 lumens.

It is probable that 100-watt lamps would be considered sufficient in most school class rooms as it is not necessary to light the entire floor area. The working area is actually about 14 ft. by 18 ft., excluding the side gangways, and if this is adopted for calculation purposes, as might quite reasonably be done, 100-watt lamps will provide the illumination desired over the working area.

### Fittings to be Used.

The shades or fittings must be selected to avoid any possibility of glare and the old open type opal shade must on no account be used. The lamps project below such shades and pupils looking at the blackboard or at charts or diagrams hung above it will find the lamps very prominent and glaring.

### Enclosed Units.

Enclosed units such as those in the laboratory in Fig. 6 are the best, but if costs must be kept down a dispersive glass reflector completely screening the lamp, such as those in Fig. 5, is desirable. Metal reflectors of this shape are sometimes used, but these leave the ceiling in complete shadow and produce an effect of gloom that is undesirable in a school.

### Master's Table.

An additional light is desirable for the master's table and usually a single pendant as shown in Fig. 3 will meet all requirements. In a class room where

charts or diagrams are regularly exhibited above the blackboard, this may be an obstruction between the pupils and the charts and in such cases a plug and table lamp may be found preferable.

If this extra lighting is provided, the four general lights can be moved farther back, thus tending to bring the lights more behind the pupils, which is all to the good. See Fig. 3.

### Blackboard Lighting.

In some cases special lighting is required for the blackboard and the Illumination Society Committee referred to above recommends that the blackboard lighting measured on the vertical plane for a vertical blackboard should be 60 per cent. in excess of the standard lighting of the room.

Special blackboard lighting is always desirable for large lecture rooms in which pupils or students may be much farther from the blackboard than in the smaller class rooms.

In class rooms it is often desirable to use a special angle reflector that will light both the master's table and the blackboard and yet screen the lamps so that there is no direct glare in the pupils' eyes. In larger lecture rooms a special fitting is usually required and in exceptional cases this may even be attached to a movable blackboard or frame to carry charts so that this is well lit in any position.

### Special Forms of Lighting.

The four centre pendants shown in the above schemes, though giving good general lighting, yet have the disadvantage that the light comes mainly from the left for some pupils, from directly overhead for others and even from the right in some seats. This is undesirable and a system of lighting with side reflectors was devised some years ago by Mr. W. A. Forsyth, F.R.I.B.A., which overcomes this difficulty. With this system the reflectors are arranged so that the artificial light comes from the same direction as the daylight. The illustrations—Figs. 1 and 4—show two rooms lit in this way. That in Fig. 1 is of a small lecture theatre and has the desks

arranged on a "stepped" floor and the general lighting is obtained from a single row of reflectors fixed above the windows. Separate fittings are provided over the lecture table to ensure ample lighting for lecture demonstrations.

Fig. 4 shows a class room, the width of which at right-angles to the windows was in excess of standard and this made it advisable to provide two rows of reflectors, one above the windows and the other fixed to a beam about one-third across the room. No separate blackboard lighting was found to be necessary but a plug was actually provided above the blackboard as a precaution in case it was required.

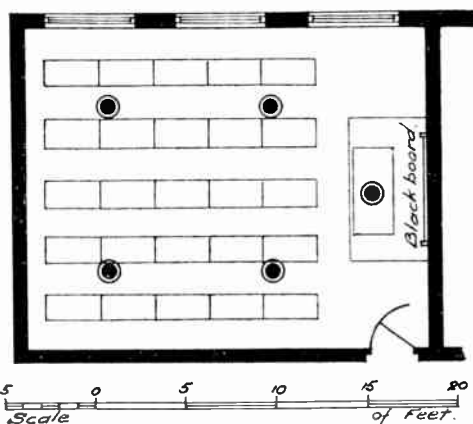

Fig. 3.—LIGHTING FOR SCHOOL CLASS ROOM. Suitable arrangement of lighting units with extra light over master's table. Note that fittings are all moved farther towards the back of the room.

The type of reflector to be used needs considerable care in selection, as it is desirable to use a type that, whilst having a high efficiency, yet will diffuse the light well and have a minimum of glare, though the last condition is not of great importance as the fittings are fixed well out of the direct line of vision.

### LECTURE ROOMS.

Lecture rooms can usually be treated as large class rooms, the illumination required being about the same. They may vary widely in size, but each can be designed on the same principles.

The problem becomes complicated if, as is usual with the larger theatres, the seats are arranged on a slope, as this involves great risk of the lighting units being directly on the eye line between the students at the back of the theatre and the blackboard or chart screens.

The Illuminating Engineering Society made a special recommendation on this point which reads as follows:—

“No source of light should be situated below a line drawn from a point on the back wall 3 ft. 6 in. above the floor to a point 4 ft. above the upper edge of the blackboard surface, unless it is completely screened from the eyes of pupils by an opaque screen. In the case of a room having a sloping or stepped floor, rising away from the blackboard, the 3 ft. 6 in. is to be measured from the elevated floor surface at the end of the room remote from the blackboard.”

This problem is still more troublesome if a lantern is provided, in which case the lantern screen may reach up to the ceiling of the theatre. In such cases the fittings must be kept hard up to the ceilings and the opaque shields round each fitting to screen the light from the students' eyes, as suggested in the report quoted above, will certainly be necessary.

The need for cleaning such fittings and fixing new lamps must be kept in mind, and, if necessary, lowering gear provided for those at the front of the theatre, as it will be difficult to fix trestles or steps on the stepped floors to obtain access to the fittings.

#### **Plugs on the Table.**

Provision must be made in these larger lecture rooms for one or two plugs on the lecturer's table, particularly if a lantern is to be used, in which case the lecturer must have a screened lamp to enable him to read his notes or manuscripts when the theatre is in darkness whilst the lantern is used.

### **LABORATORIES.**

The ordinary school laboratory requires rather better lighting than the class rooms. The Illuminating Engineering

Society recommend a minimum of 8 ft. candles for such rooms (workshops, art schools and so forth), but 10 ft. candles would be desirable for the best results.

It is usually sufficient to provide only general lighting and this can be arranged in accordance with standard principles and with fittings similar to those suggested for the class rooms.

Local plugs may be required on benches, but these are needed rather for experimental work than for actual illumination.

#### **Local Lighting.**

In more advanced or research laboratories local lighting will be required and the general lighting can be reduced to about 6 or 8 candle feet. These local lights will be arranged round the laboratory benches and the number must depend on the structural arrangements of the benches. Work will usually be carried on directly in front of the windows and this being so, a pendant in front of each window will, in most cases, meet all requirements.

#### **Deciding the Type of Fitting to Use.**

Some authorities prefer brackets to pendants and others fixed pendants rather than the rise and fall type—or fixed brackets instead of adjustable kinds. Such matters must depend very largely on the personal preferences of the master or professor in charge and do not really affect the lighting scheme, which can easily be arranged to suit. The authority concerned should always be consulted in good time as to his views on such matters, as otherwise much dissatisfaction—often unjustified—may result.

If there is a master's table—not always provided in a laboratory—a special light should be provided for this and also special lighting for the blackboard if one is used.

Figs. 5 and 6 show two typical laboratories, in both of which good general lighting is provided. In Fig. 5 the lights are provided with open type reflectors of a type that completely covers the actual bulbs. The fittings are suspended both from the beams and between the beams, the spacing being arranged to suit the architectural features of the room. Local

lighting for the fume cupboards on the left of the illustration is provided by brackets with metal reflectors and other local lights are provided for the side benches.

The laboratory in Fig. 6 is lit by enclosed type lighting units spaced between the beams and additional local pendants are provided over the bench on the window side of the room. Plugs for experimental work may be seen on the ends of the central benches and on the bench by the windows.

#### Fume Cupboards.

Special lighting for the fume cupboards is not always necessary in the ordinary school laboratory but it is certainly desirable for more advanced work where the processes going on in the fume cupboards may need careful attention. Such lights should never be placed inside the fume cupboard as the fumes will rapidly destroy the metalwork of the fittings and lamps. Pendants or brackets outside to light through the glass roof or front of the cupboard must be fitted with care so that the moving fronts of the cupboards do not foul the fittings. Brackets for lighting the fume cupboards are shown in Fig. 5.

#### Balance Rooms.

In these rooms also different lighting is required according to the class of work being done. In junior laboratories special lighting is probably not necessary if adequate general lighting is provided. For more advanced work the balances will probably be located in a special balance room, a number being fixed side by side on a specially rigid table. For such

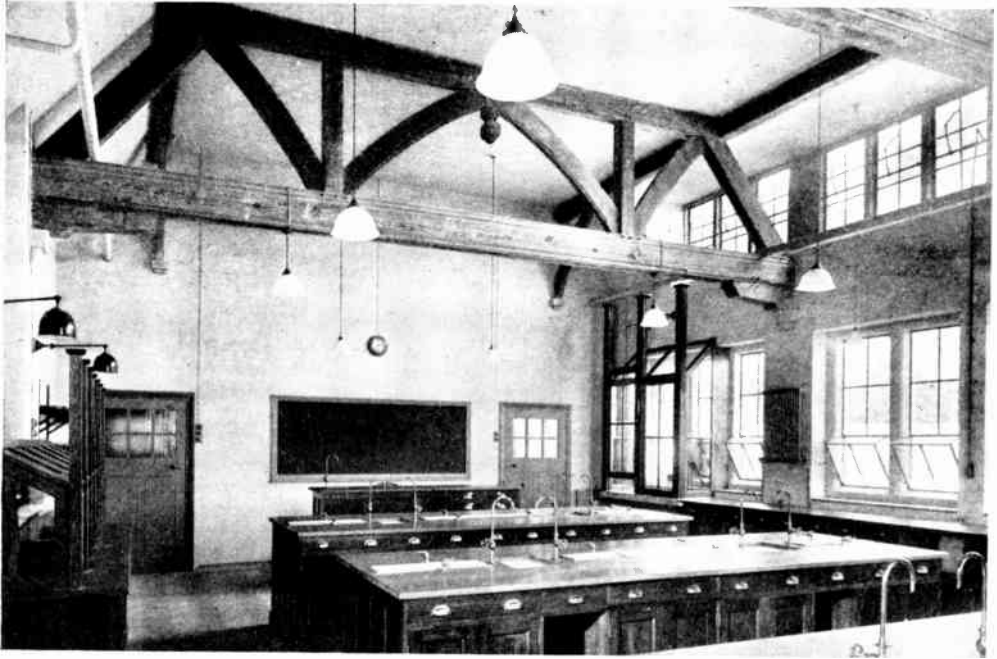

Fig. 4.—CLASS ROOM LIT BY SIDE REFLECTORS WITH EXTRA ROW ON BEAM ACROSS THE ROOM.

The extra lights are required owing to the room being very wide.

balances a local light is really necessary for each balance, but the result can be more conveniently obtained by straining a steel wire about 8 or 9 feet from the ground and arranging two or three pendants with slack flexible cord so that the pendants can slide to and fro along the wire. One fitting will then serve for two or three balances, and the fitting can be moved slightly to bring the lamp to the best position for using the balance. The fittings should be arranged with the lamps slightly in front of the balances.

The lamps must not be too close to the balances as the heat from a lamp close to a delicate balance might be sufficient to spoil its accuracy. The arrangement suggested is illustrated in Fig. 7.



*Fig. 5.*—SCHOOL LABORATORY WITH OPEN TYPE REFLECTORS.  
Note the extra lighting brackets over fume cupboards on the left.

### ART CLASS ROOMS.

Rooms devoted to art classes need special attention. They are usually arranged with north daylight, and it is generally desirable that the electric lighting should be designed to correspond with this, but unless heavy expense is incurred in providing lighting effects of the same character as daylight this may be difficult. The results can be obtained by flood lighting from behind a skylight, but the cost is high and such schemes can rarely be adopted in ordinary school installations.

If less ambitious designs must be adopted, two points must receive special attention:—

- (1) The fittings must be arranged to avoid all risk of glare for the students when looking at the model.
- (2) Cross shadows on the model must be entirely eliminated.

The first result can be achieved by having the lighting fittings fixed very high and out of the eye line, or by having them well screened.

The second requirement involves the use of a special fitting to light the model and this should be designed preferably with adjustments so that the fitting can be raised or lowered and tilted in various directions.

Fig. 8 shows a special design for an art room fitting, which proved very effective. The lamps for lighting the students' work were placed round a large oak frame which reflected the light down on the work below and also screened the lamps from students on the other side of the room and from the model, thus avoiding cross shadows. The model was separately lit by a central adjustable fitting.

If the room is to be used for colour work, daylight lamps may be desirable, but this again involves heavy cost if satisfactory results are to be obtained. The ordinary blue glass lamp is sufficiently accurate for rough colour washes, but is not accurate enough for more delicate work.



Fig. 6.—SCHOOL LABORATORY WITH ENCLOSED UNIT FITTINGS.  
There are also local lamps over side benches.

## LIGHTING FOR THE OTHER PARTS OF A SCHOOL.

### Libraries.

The ordinary school library does not as a rule call for any special lighting. It may only be used as an occasional work-room or for reference purposes, and in such cases good general lighting up to 6 or 8 candle feet will provide all that is necessary.

If it is used for more regular study, local desk lamps will be desirable in addition. Tables for work of this kind will usually be placed by the windows and plugs for desk lamps also by the windows will be in suitable positions.

### Dining Halls.

Dining halls used for meals and nothing else are rather the exception than the rule, and usually such rooms are used for preparation work or recreation as well as for meals.

If used for meals only, general lighting up to 3 or 4 candle feet will be sufficient.

If used for preparation work, this standard must be doubled, as 6 to 8 candle

feet will not be too much for boys working for two or three hours on end.

It is sometimes necessary to add special lighting either for a master's table or for a serving table and each such room must be considered specially as regards any requirements of this character.

### Manual Training Rooms.

These rooms must be treated as work-shops and in most cases the lighting will be best obtained from local fittings. The general arrangement of the benches and work tables must be studied and in any case good general lighting be provided of not less than 5 foot candles, this being increased if local lighting is not added.

### Engineering Shops.

For engineering shops, local adjustable brackets on the benches and at the more important tools should be provided in addition to general lighting equal to 6 or 8 foot candles. Great accuracy in setting out is necessary and this cannot be obtained unless the lighting is very good. Such work only needs to be done at various

specials position on the benches, and a local light at each such position is more satisfactory than a largely increased general lighting scheme.

### Carpenters' Shops.

For carpenters' shops, general lighting of 8 to 10 candle feet will be suitable. The setting out is not usually so accurate and it is also frequently necessary to have central benches with boys or students working on both sides. With such a lay-out of benches, local lighting is not likely to be satisfactory as shadows would be unavoidable.

### Domestic Class Rooms.

General lighting up to 8 to 10 candle feet will be best for these. It will certainly be best for cookery class rooms, for laundries and general domestic science

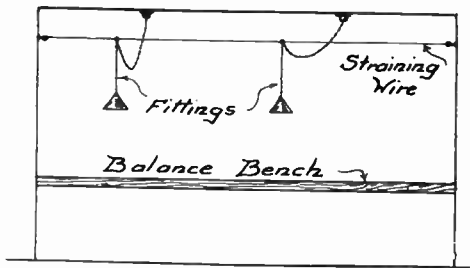

Fig. 7.—ARRANGEMENT OF LIGHTING BALANCES.

The lamps are suspended from a strained wire fixed above the balances on which the fittings can slide along so that the light can be moved to the desired position over any balance.

rooms. For sewing rooms local lighting may be necessary but unless the work done is very fine, general lighting should be satisfactory for these also, particularly if the standard of illumination is raised to 12 candle feet or more.

### Boys' Studies.

The lighting of boys' studies in public school boarding houses must depend on the school. In some cases, studies are provided for each boy, or at any rate for the senior boys, and for these one 60-watt lamp per study will be ample. In other schools the studies are larger and may be used by two, three or even up to six boys,

and one or two fittings with 60-watt lamps can be provided according to the size of the room. The whole area must be well lit in studies occupied by several boys as they may all be working in all parts of the room.

### Dormitories.

The habits of the school must again be considered in arranging the dormitory lighting. In most schools reading in bed is either discouraged or prohibited, and then comparatively little lighting is wanted. If reading is allowed this must be taken into account in scheming the lighting installation and higher illumination provided.

As a general rule, three or four lamps of 60 watts will be sufficient for lighting the normal school dormitory with accommodation for ten or twelve boys.

### School Chapels.

These do not require treatment different from that already described for churches and the same principle of lighting can be used. In a typical school chapel two rows of five-light pendants might be provided in the nave and a row of three-light pendants in each aisle.

### School Halls.

In the larger schools the Great Hall is only used for general functions such as lectures, concerts, speech days and so on, and for such purposes high illumination is not required. If the scheme is designed for 5 candle feet it should be ample but allowance must be made for the use of special fittings to suit the character of the building and wiring arranged accordingly.

Rather better lighting may be required over the platform, though this is often adjusted by using slightly larger lamps.

Provision must often be made for stage lighting but not on an elaborate scale. Plugs for footlights with three colours, and for top battens also with three colours, and one or two extra plugs for special requirements will usually be ample. If the school does regularly give theatrical performances, extra plugs for spotlights should also be added and it may also be



necessary to provide plugs for orchestra lighting.

If the school hall is used for other purposes—and such buildings are sometimes available for other than school purposes—this must be taken into account in designing the installation, and it may be necessary to increase the illumination up to 8 or 10 candle feet. This will certainly be necessary if the hall is used for examinations.

### Corridors and Staircases.

Normal lighting only is required for the corridors and pendants spaced about 30 to 40 ft. apart will be sufficient. An exception must be made if school notices, etc. are placed in the corridors and if this is done the lighting must be arranged so that there is ample light at any such wall areas.

Staircase lighting requires rather more care and should be designed for not less than 3 foot candles, whilst the fittings must be arranged so that the treads of the steps are well illuminated. The illumination test should be made at these

points. Fittings must also be arranged so that there is no direct glare in the eyes of the boys going up and down—and particularly down—stairs. Each flight of stairs should be lit, if possible, both from above and from below.

### Changing Rooms, Locker Rooms, etc.

These do not require any special design apart from arranging the lamps to give fairly good lighting where it is most required. The lamps should, for example, be placed between rows of lockers or coat-racks or over benches in changing rooms, but the details must be decided to suit the planning of each such room.

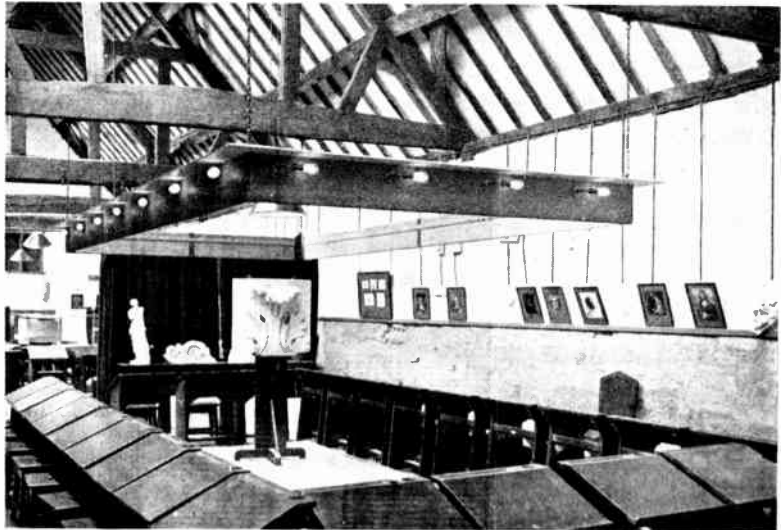

Fig. 8.—ART ROOM LIGHTING FIXTURE.

The lamps are placed round a special angle frame which allows the light to fall on the pupils below whilst screening it from those across the room. The model in the centre is lit from a separate central adjustable fitting.

## QUESTIONS AND ANSWERS

**What is the minimum number of foot candles required for lighting a class room ?**

Five foot candles is the minimum, but a standard of eight candle feet should be provided.

**What type of shades or fittings would you advise for a class room ?**

Enclosed units are the best, but if costs

must be kept down a dispersive glass reflector completely screening the lamp may be used.

**What special precautions must be taken when lighting an art class room ?**

(1) The fittings must be arranged to avoid all risk of glare for the students when looking at the model ;

(2) Cross shadows on the model must be entirely eliminated.

# FLOOD-LIGHTING

## AND HOW TO OBTAIN THE BEST RESULTS WITH IT

By A. H. BRACKENSEY

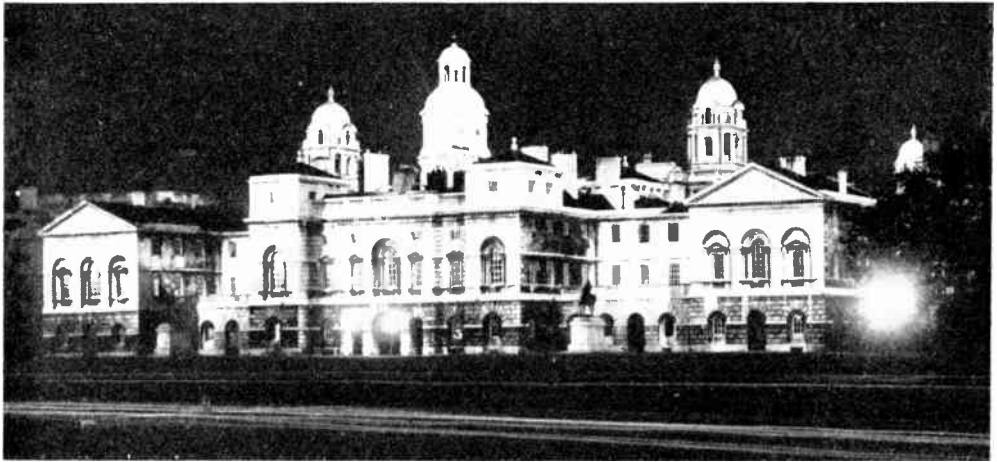

*Fig. 1. — A TYPICAL EXAMPLE OF SUCCESSFUL FLOOD-LIGHTING. (Brown Bayleys).  
Showing the use of stainless steel for reflectors for flood-lighting the Horse Guards' Parade.*

**F**LOOD-LIGHTING, which is an expression which has come into being within the last few years, is an art which has but recently reached anything like efficiency. Flood-lighting means that light is projected upon an object from a hidden source, so that there must be some sort of screen between the light and the observer, otherwise the effectiveness of the throw of the light would be very materially decreased by virtue of the light itself being seen. All forms of light have some focal point of intensity. Even the humble candle has its comparatively bright spot, although the diffusion from the light is spread over many times the area of the flame itself.

### THE PROJECTOR TYPE OF FLOOD-LIGHTING.

The most popular form of flood-lighting at present is that which concerns the illumination of buildings, monuments, etc., and for this purpose we have to

consider two types of flood-lights. The first, which is the most popular, consists of a circular form of lamp containing a 500-watt or a 1,000-watt focus filament gas-filled lamp. These lamps are specially made for projector flood-lighting and have their filaments in a very small area for focussing purposes. The interior of the lamp is fitted with a highly polished parabolic reflector, the latest form being chromium plated. This plating is the most modern form known and has the property of being practically stainless, and retains its reflecting properties for a long time against weather conditions.

### Obtaining the Correct Focus.

The lamp is fitted with a giant screw-lamp holder which is adjustable, to allow the correct focus to be given. The best type of lamp has a heat resisting front glass, as otherwise there would be a danger of the glass cracking should rain impinge on the hot surface. This type of lamp

is used where a long throw is desired. A lamp such as this will give a throw of 1,000 feet and can be adjusted to produce a comparatively narrow beam, so that all the light is focussed in a comparatively small space at the end of its throw.

#### **How "Big Ben" was Illuminated.**

This is the type of lamp which was used recently for illuminating the "Big Ben" tower in London. To illuminate one side of the tower, 36 such lamps were arranged in four ranks of nine. The first four were focussed to illuminate the lower quarter of the tower; the next four, higher up, and the last four were focussed to illuminate "Big Ben" and the top portion. The lighting was very effective, and it will be seen that true flood-lighting requires a comparatively large number of lamps. A further instance—Buckingham Palace—was flood-lit by similar projectors, 180 of which were required to carry out the scheme. It may be here noted that shortly before the installation was carried out, Buckingham Palace had been thoroughly cleaned, and presented its original light stone colour. Had this not been the case, double the number of lamps would not have given the same effect.

#### **Buildings Must be Clean to Obtain Good Results.**

To obtain the maximum results the building should be clean, or a light colour. The more dingy the building the greater difficulty will be experienced in flood-lighting it. It would not be possible to flood-light a dark slate roof, for instance.

You cannot reflect back light from a black object. Some time ago the writer was given permission by the authorities to experiment in flood-lighting Nelson's Column in Trafalgar Square. Owing to the monument being so dark, however, it was found impossible to carry it out satisfactorily. Even a red brick building is in no way ideal for flooding. It must always be borne in mind that *the efficiency of flood-lighting is largely dependent upon the reflection from the object which is being illuminated.*

#### **When to Use the Projector Type.**

The projector type of flood-lamp is usually used as follows:—

- (1) Where the most convenient position for the flood-light is, say 50 or 60 feet away from the object to be flood-lit;
- (2) Where a small object such as a statue or ornamentation at the top of a building has to be lit from a distance.
- (3) Where practically no projection at all can be obtained, so that the light has to be turned up vertically to illuminate the face or columns of a building. This last application is one which is very popular for lighting buildings in main roads. Owing to the restricted projection of lamps, etc., by the local authorities, the projector form of flood-light is the only efficient and practical means.

#### **Flood-lighting for Long Distances.**

It will be seen that with the beam of light available from this projector it is possible to light up for a long distance a vertical section of wall, probably terminating in the illumination of the under side of the coping on the upper part of the building. An excellent illustration of this method of flood-lighting can be seen on the building of Messrs. Selfridge in London, where the flood-lights do not project over the building line.

#### **THE REFLECTOR TYPE OF FLOOD-LIGHTING.**

There are many cases where buildings such as factories, exhibition pavilions, cinemas, etc., have a certain amount of ground surrounding them and are not more than perhaps 25 to 30 feet in height. The projector type of flood-light would be unsuitable for these as here the beam of light is not wanted but a really true flood of light. This necessitates a second type of lamp altogether. This is constructed in a variety of ways and is usually a cheaper type of article. It can consist of a box-like container which may be lined with silver-fluted mirror. The front of this box is fitted with a heat-resisting glass, the interior having a 500-watt or 1,000-watt gas-filled lamp which, in this case, need not be of a focus variety—the ordinary variety are cheaper. The lamp is usually provided with feet so that it stands on either the ground or a

slab of stone or other convenient footing. Another type, which is of a somewhat similar shape and is in fact favoured by the writer, is made of a stouter metal and is fired with porcelain vitreous enamel, black outside and white inside. Little advantage is gained with the fluted mirror, which may tend to become discoloured in time owing to the action of the heat and the weather, whereas the porcelain enamel withstands all climatic conditions for very long periods.

### How the Reflectors are Placed.

Reflectors of this type are usually placed on the ground some 30 feet away from the object which is being illuminated, and lamps can be spaced some 25 feet apart and will be found to give an excellent degree of illumination.

### When the Reflector-Type is Unsuitable.

It should be borne in mind that if the building is 40 or 50 ft. high, this type of reflector will not do the work efficiently; the lower part of the building will be well lit, and the light will trail off as it goes to the top—an undesirable condition of affairs.

If the building is high, a good combination would be for the projector lamps to illuminate the top portion and the flood-lights to illuminate the bottom portion. By this means, even distribution will be attained.

### Flood-lights of Various Colours.

In many cases, pleasing effects can be obtained by using flood-lights of various colours. To obtain this is quite a simple matter as it merely means that a separate complete set of lamps has to be provided for each colour. Do not attempt to colour varnish the front glass as the heat of the lamp will either discolour or burn this away. Screens of real coloured glass could be obtained and placed in front of the clear glass and this will be found perfectly satisfactory. The best method of changing colour is by means of a diffusing effect—one colour to dim out while the second colour becomes bright. This can be obtained by a motor-operated rotary switch arm in connection with resistance coils. As the arm rotates

so the resistance increases in one set of lamps and decreases in the lamps of the second colour.

### HOW TO OBTAIN THE BEST RESULTS.

(1) Do not attempt to use projector lamps for close range lighting. These should be used where your throw is over 50 feet, except where vertical lighting is required.

(2) You will not get good results with too few reflectors—use sufficient.

(3) Do not expect to get first-class results by attempting to flood-light a dingy building. It will be cheaper to persuade the owner to have it cleaned if flood-lighting is in contemplation.

(4) See that your flood-lights of both types are weather-proof, otherwise the reflecting properties may soon diminish. Good flood-lights are cheapest in the long run.

(5) See that your projector lamps have proper focussing arrangements. Without these you will not get adequate range of adjustments.

(6) For flood-lighting, supply companies usually give a cheap rate of current. Enquiries should be made from the local supply.

(7) If the installation is temporary, ordinary cable can be used without further protection. If permanent, use steel-screwed conduit—preferably galvanised—for outside use.

(8) It is cheaper to run heavy mains to a distribution box adjacent to the lamps than to run circuits back into the building.

(9) It is not desirable to run more than 2,000 watts per circuit.

(10) If you are using 500-watt lamps, do not forget that your wiring can be reduced as you extend from lamp to lamp, the mains feeding the last lamp taking the lowest current.

(11) For a permanent installation do not expect more than 600 or 700 hours lighting from your lamps. It is cheaper to buy a new lamp than to continue using one, the lighting efficiency of which has diminished with age.

(12) Use 1,000-watt lamps, where possible. It is better to be on the right side than to have a disappointing result.

# STARTERS AND CONTROL GEAR FOR A.C. INDUSTRIAL MOTORS

By A. T. DOVER, M.I.E.E.

## How Fractional H.P. and Small Motors are Started.

ALL types of three-phase and single-phase fractional h.p. motors are started by switching the stator windings directly on to the supply mains. Typical connection diagrams are shown in Figs. 1A, 1B, 2, 3. Small squirrel-cage and repulsion motors may also be started in this manner, provided that the starting is effected quickly and that the starting currents are within the limits allowed by the supply authority. These limits vary considerably in different cases. Thus on some lighting and power networks direct switching is restricted to motors not exceeding 3 h.p., but with industrial works receiving a bulk supply,

direct switching of motors up to about 20 h.p. is usually permissible. Again, in large power stations and private supplies (e.g., collieries), motors up to about 100 h.p. may be started directly when the starting conditions are suitable.

## Starting Current and Starting Torque of Three-phase Motors with Direct Starting.

Although direct switching of three-phase squirrel-cage motors is usually desirable whenever possible in order to save the cost of special starting apparatus (which may be as costly as the motor), this procedure involves large initial currents, and in consequence the starting must be effected quickly if these currents

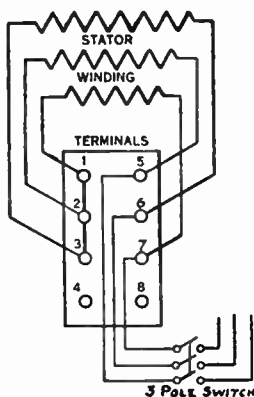

Fig. 1A.—CONNECTIONS FOR DIRECT SWITCHING OF THREE-PHASE MOTOR. STAR-CONNECTED STATOR WINDING.

Note.—Small motors frequently have a six-terminal stator winding in order that star or delta connections may be made at the terminal board to suit the supply voltage.

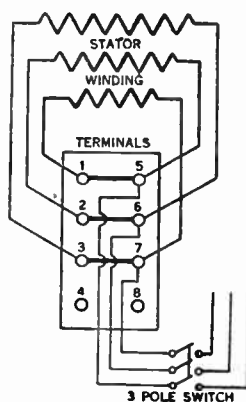

Fig. 1B.—CONNECTIONS FOR DIRECT SWITCHING OF THREE-PHASE MOTOR. DELTA-CONNECTED STATOR WINDING.

The simple starting arrangements shown in Figs. 1A, 1B and 2 should be used only with fractional h.p. motors. The starting switches for larger motors should have protective devices.

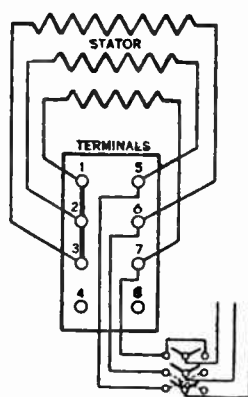

Fig. 2.—CONNECTIONS FOR DIRECT SWITCHING OF THREE-PHASE REVERSIBLE MOTOR.

The main switch is of the three-pole double-throw type. The fixed contacts of two poles are cross connected, as shown by dotted lines, and those of the other pole are looped across as shown by full lines.

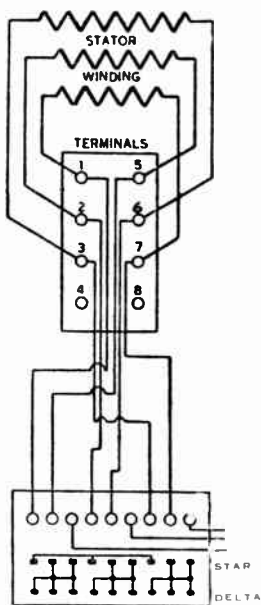

Fig. 3.—CONNECTIONS OF STAR-DELTA STARTER, SIMPLE DRUM TYPE.  
 Note.—The diagrams Figs. 1A to 4 and Fig. 8 refer to Crompton-Parkinson starters and motors.

are not to cause damage. Quick starting involves rapid acceleration, which requires a large torque from the motor. Starting current and starting torque must, therefore, be given careful consideration when direct switching is to be used. Both of these quantities, expressed in terms of full-load current and torque, depend upon the design of the motor, size of frame, number of poles, etc. Average values for standard 50-cycle motors are given in Table I on page 1204.

Thus with a 4-pole motor, the initial current will be between 6.5 and 7.5 times the full-load current and the initial torque will be about 2.5 times the full-load torque. This initial torque is sufficient to give rapid acceleration in all the usual applications of squirrel-cage motors; it being understood that these motors would not be used for starting loads possessing considerable flywheel effect. On the other hand, a 6-pole or an 8-pole motor will require lighter starting duty in order to obtain rapid acceleration.

**How Larger Three-phase Squirrel-cage Motors are Started.**

When it is not permissible to start a three-phase squirrel-cage motor by direct switching, the motor must be started at reduced voltage. The reduction of voltage may be obtained in a number of ways, such as by regrouping the stator windings (e.g., by star and delta connections, or by series and parallel connections), by an

auto-transformer, or by a rheostat in series with the stator windings. Series-parallel connections, however, are not used with three-phase motors on account of the large number of terminals and connections involved. Accordingly, such (stator) starters are called *star-delta*, *auto-transformer*, *rheostatic*. Typical connection diagrams are shown in Figs. 4 and 5.

**Starting Current and Starting Torque of Three-phase Motors with Star-Delta Starting.**

The star-delta starter is simply a change-over switch—preferably with protective devices—for giving two systems of connection for the stator windings of a three-phase motor, viz., the star connection for starting and the delta connection for running. Obviously, six terminals are necessary on the motor, as no internal interconnection of the phases of the stator windings is permissible.

When the windings are star connected the voltage per phase is  $0.577 (=1/\sqrt{3})$

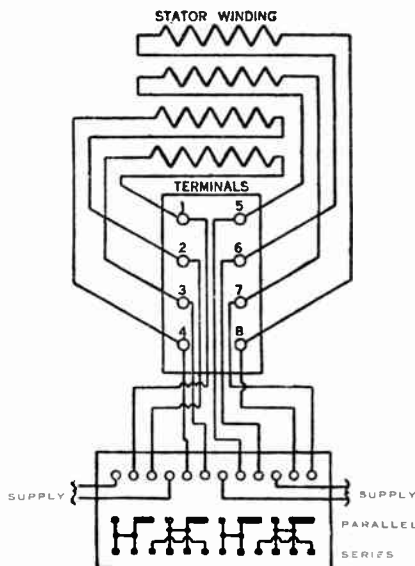

Fig. 4.—CONNECTIONS OF SERIES-PARALLEL STARTER (SIMPLE DRUM TYPE) FOR TWO-PHASE MOTOR.

Series-parallel starters are not used with three-phase motors on account of the large number of connections involved. Moreover the star-delta method (Fig. 3) is simpler and gives a better starting performance.

of the line voltage, and, therefore, the star-delta method of starting is equivalent to supplying each phase of the motor at starting with only 57.7 per cent. of the normal line voltage. Thus the starting current in each phase of the stator winding is only 57.7 per cent. of that corresponding to direct switching with normal (delta) connections. But with direct switching the line current would be  $\sqrt{3}$  ( $= 1.73$ ) times the current in each phase of the winding. Thus the change of connections from delta (normal) to star (starting) not only reduces the voltage applied to each phase of the stator winding in the ratio of 1 : 0.577, but also reduces the *line* current in the ratio of 1 : (0.577 /  $\sqrt{3}$ ) or 1 : 0.333, i.e., 1 :  $\frac{1}{3}$ .

As the torque of a squirrel-cage motor is approximately proportional to the *square* of the stator voltage per phase, the starting torque with the star connected winding will be *one-third* [ $= (1/\sqrt{3})^2$ ] of that obtained by direct switching with the normal delta connected winding.

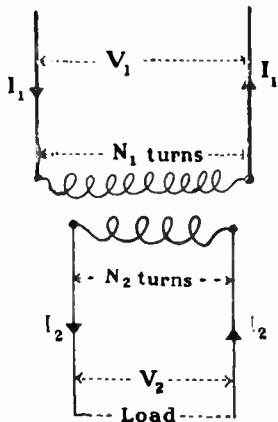

Fig. 30.—CIRCUITS OF ORDINARY TRANSFORMER.

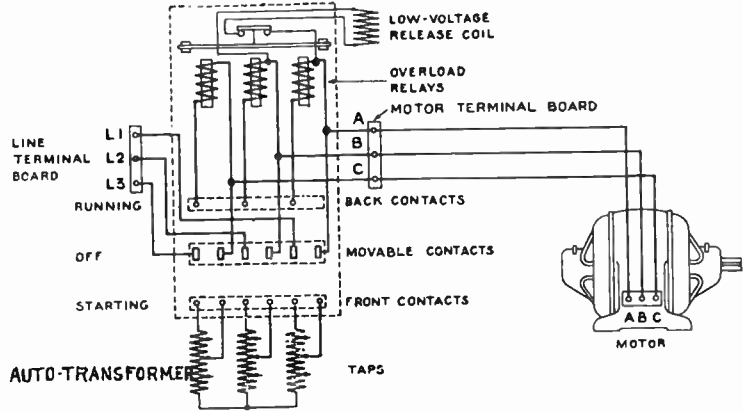

Fig. 5.—CONNECTIONS OF AUTO-TRANSFORMER STARTER. (B.T.H. Co.)  
The auto-transformer is of the three-phase type, and the change-over switch is of the lever type.

pondering quantities for star-delta starting. For example, referring to Table I, the  $7\frac{1}{2}$  h.p., 4-pole motor, frame size E, which, with direct switching, has a starting current of 7.5 times full-load current and a starting torque of 2.5 times full-load torque, would, with star-delta starting, have a starting current of  $\frac{1}{3} \times 7.5 = 2.45$  times full-load current and a starting torque of  $\frac{1}{3} \times 2.5 = 0.833$  times full-load torque.

**Auto-transformer Starting of Three-phase Squirrel-cage Motors.**

The auto-transformer starter consists of a change-over switch and an auto-transformer, by means of which the motor, at starting, is supplied at reduced voltage. Usually three tappings—giving voltages of 50, 60 and 75 per cent. of the normal line voltage—are provided in order that the voltage applied to the motor at starting may be selected to suit the starting conditions. This, then, is the advantage of the auto-transformer starter compared with the star-delta starter (in which the starting voltage is a fixed percentage).

**Why an Auto-transformer is Used.**

An auto-transformer (i.e., a transformer in which a portion of the turns are common to both primary and secondary circuits) is used in preference to an ordinary transformer (which has separate

Thus with star-delta starting both the starting current and the starting torque are only one-third of those corresponding to direct switching the same motor on to the supply.

Hence, knowing the starting current and starting torque for direct switching, we can easily obtain the corres-

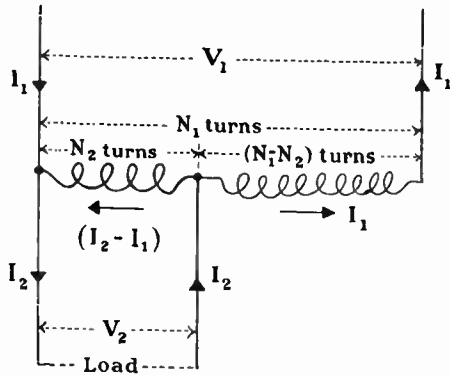

Fig. 7.—CIRCUITS OF AUTO-TRANSFORMER. Showing that a portion of the load current is obtained directly from the supply.

primary and secondary windings) because with the low ratios of transformation required, the former is very much cheaper than the latter, due to the power output of its secondary winding being only a portion of the power supplied to the motor. The comparison between the two forms of transformer is shown in the diagrams of Figs. 6 and 7. Thus, with an ordinary transformer the whole of the volt-amperes required by the load must be supplied by the secondary winding, whereas with an auto-transformer a portion,  $V_2I_1$  of the load volt-amperes is obtained *directly* from the supply system, and in consequence the secondary winding has only to supply the difference, viz.,  $V_2(I_2 - I_1)$  volt-amperes. For example, if the secondary voltage is one-half of the supply

voltage, the output of an auto-transformer to supply a given load will be one-half of that of the corresponding ordinary transformer, because one-half of the load volt-amperes will be obtained directly from the supply system. Hence in this case the auto-transformer will be considerably cheaper than the ordinary transformer.

### Starting Current and Starting Torque of Three-phase Motors with Auto-transformer.

From the principle of the transformer we know that the ratio of the secondary and primary currents is approximately proportional to the ratio of the primary and secondary voltages. Thus, if the secondary voltage is one-half of the primary voltage, the primary current will be approximately one-half of the secondary current. Hence, if a motor is started on the 50 per cent. tapping of the auto-transformer the motor current at starting will be one-half of that corresponding to direct starting. But the *line* current will be approximately one-half the motor current, or one quarter of the current corresponding to direct starting. As the starting torque is approximately proportional to the *square* of the voltage applied to the motor, the starting torque obtained when a motor is started on the 50 per cent. tapping of the auto-transformer will be approximately one-quarter of that obtained with direct starting.

Similarly, if the 75 per cent. tapping is used, the motor current is three-quarters

TABLE I.—AVERAGE VALUES OF STARTING CURRENT AND STARTING TORQUE FOR THREE-PHASE MOTORS WITH DIRECT SWITCHING STARTING.

4 poles.	Rated h.p. .. ..	1	2	3	5	7½	10	15	20	25
	Frame size .. ..	A	B	C	D	E	F	H	J	J
	Starting current* .. ..	6	6.5	6.5	6.5	7.5	7.3	7.8	7	7
	Starting torque† .. ..	2	2.25	2.5	2.5	2.5	2.3	2.3	2.3	2.3
6 poles.	Rated h.p. .. ..	1	2	3	5	7½	10	15	20	25
	Frame size .. ..	B	C	D	E	G	H	J	K	L
	Starting current* .. ..	5.25	5.5	5.5	6	6.5	7.2	6.5	8.8	9
	Starting torque† .. ..	1.5	1.7	1.7	2.2	1.8	1.8	1.9	1.7	1.7
8 poles.	Rated h.p. .. ..	3	5	7½	10	15	20			
	Frame size .. ..	E	G	H	J	K	L			
	Starting current* .. ..	5.3	5.5	6	6.5	7.5	8			
	Starting torque† .. ..	1.6	1.6	1.6	1.8	1.4	1.4			

\* Times full-load current.

† Times full-load torque.



of that corresponding to direct starting, and the line current is three-quarters of the motor current, or  $\frac{3}{4} \times \frac{3}{4} = \frac{9}{16}$  of that corresponding to direct starting. The starting torque is approximately  $(\frac{3}{4})^2 = \frac{9}{16}$  of that obtained with direct starting.

Hence with auto-transformer starting the LINE current and the motor torque are each equal to the square of the transformer tapping (expressed as a fraction) times the current and torque corresponding to direct starting.

For example, referring to Table I, the  $7\frac{1}{2}$  h.p. 4-pole motor, frame size E, which, with direct starting, has a starting current of 7.5 times full-load current and a starting torque of 2.5 times full-load torque, would, with auto-transformer starting, give the following line currents and starting torques on the various tappings of the auto-transformer:—

50 per cent. tapping—line current =  $(\frac{1}{2})^2 \times 7.5 = 1.875$  times full-load current; torque =  $(\frac{1}{2})^2 \times 2.5 = 0.625$  times full-load torque.

60 per cent. tapping—line current =  $(\frac{3}{5})^2 \times 7.5 = 2.7$  times full-load current;

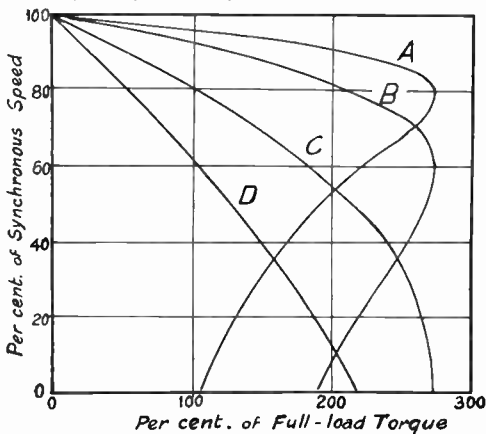

Fig. 9.—SHOWING HOW THE STARTING AND RUNNING TORQUES OF A THREE-PHASE MOTOR DEPEND UPON THE EXTERNAL RESISTANCE IN THE ROTOR CIRCUIT.

Curve A, external resistance zero (i.e., slip rings short circuited); B, external resistance twice resistance of rotor winding; C, external resistance five times rotor resistance; D, external resistance 10 times rotor resistance.

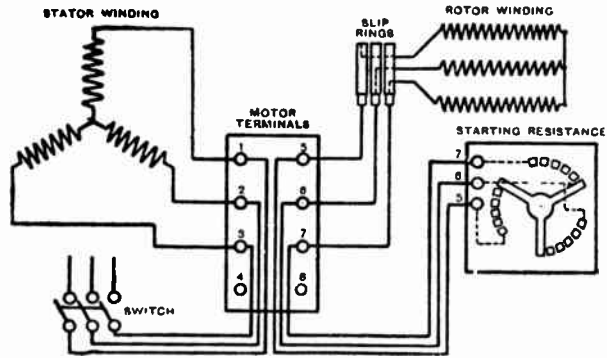

Fig. 8.—CONNECTIONS OF ROTOR STARTER FOR THREE-PHASE MOTOR.

rent; torque =  $(\frac{3}{5})^2 \times 2.5 = 0.9$  times full-load torque.

75 per cent. tapping—line current =  $(\frac{3}{4})^2 \times 7.5 = 4.5$  times full-load current; torque =  $(\frac{3}{4})^2 \times 2.5 = 1.4$  times full-load torque.

### Rheostatic Starting of Three-phase Squirrel-cage Motors.

This method—in which the reduced voltage applied to the motor is obtained by means of resistances connected in series with the stator windings—is occasionally used with small motors. Although the starting performance does not compare favourably with the star-delta and auto-transformer methods, the starting operation can be made more uniform, and the current peaks which occur with the other methods during the change-over are avoided.

### Starting Current and Starting Torque of Three-phase Motors with Rheostatic (Stator) Starting.

With a rheostat connected in series with the stator windings the starting current is reduced in the same ratio as the voltage at the motor terminals. Thus, with half normal voltage at the motor terminals the starting current is one-half of that corresponding to direct starting. But, as the starting torque is proportional to the square of the voltage at the motor terminals, the starting torque at half normal voltage is one-quarter of that obtained with normal voltage. For

TABLE II.—TYPES AND APPLICATIONS OF STARTERS FOR THREE-PHASE MOTORS.

	Type.	Max. h.p. for which starter is suitable.	Max. duration of starting period (seconds).	Max. number of starts per hour at full-load torque.	Minimum interval between successive starts at full-load torque.	Suitable for
Stator Starters for Squirrel-cage Motors.	Direct . . . . . (Hand-operated and contactor)	Up to 3 or 5 h.p. or larger, according to Supply Co.'s regulations	—	—	—	Reversing and non-reversing motors driving loads which can be started quickly (i.e., loads with small flywheel effect).
	Star delta (hand-operated)	100	—	—	—	Light load starting. Machine tools, centrifugal pumps, etc.
	Do. do. . . . . (small contactor)	7½	—	—	—	
	Do. do. . . . . (large contactor)	150	30	—	—	
Auto-transformer (hand-operated)	200	15 · ¼ h.p.	10	50 times starting period	Light and moderate load starting. Heavy machine tools, centrifugal pumps, air compressors, etc.	
Do. do. . . . . (contactor)	1,000	Do.	15	Do.		
Rheostatic (stator) (hand-operated or contactors)	15	30	4	14 times starting period	Small hoists and service (dinner) lifts with light duty starting and for which slow starting is necessary.	
Rotor Starters for Slip-ring Motors.	Faceplate . . . . . (oil immersed)	500	(5 + ½ × h.p.) up to 50 h.p. 30 (above 50 h.p. and under 200 h.p.) 60 (above 200 h.p.)	(normally) 2 (emergency) 4	1 hour (after emergency quick starts)	Non-reversing infrequent starting. Ordinary starting duty. All classes of slip-ring motors and compensated-induction motors.
	Drum controller with stator and rotor contacts	100	According to starting conditions			Reversing and frequent heavy duty. Cranes, haulages, steel mills.
	Do. with rotor contacts only	1,000				
	Control pillar . . . . . (self-contained)	340	(5 + ½ h.p.)	4	14 times starting period	Non-reversing, infrequent starting. All types of slip-ring motors and compensated-induction motors.
	Contactor . . . . .	500	15	40	14 times starting period	Reversing and non-reversing with frequent starting and heavy duty. Cranes, pumps, steel mills, etc.
Do. . . . .	Above 500	According to starting conditions				
Liquid . . . . . (common electrode tank. Natural cooling)	750 (1,500 amp. rotor)	According to starting conditions				Infrequent starting against light or heavy loads where uniform torque and absence of shocks are essential.
Liquid . . . . . (Separate electrode tanks. Natural cooling)	2,000					
Liquid . . . . . (Separate electrode tanks. Forced cooling)	Above 2,000					
						Heavy duty and frequent starting. Large winders and haulages.

example, referring to Table I, the  $7\frac{1}{2}$  h.p. 4-pole motor frame size E, which, with direct starting, has a starting current of 7.5 times full-load current and a starting torque of 2.5 times full-load torque, would, with rheostatic starting and half normal voltage at the motor terminals, have a starting current of  $(\frac{1}{2} \times 7.5) = 3.75$  times full-load current and a starting torque of only  $(\frac{1}{2})^2 \times 2.5 = 0.625$  times full-load torque. Thus, the starting performance, i.e., the ratio of torque to current, is very poor compared with that when star-delta and auto-transformer methods are used.

### How Three-phase Slip-ring Motors are Started.

Three-phase slip-ring motors are started with resistances connected in the rotor circuits, the full supply voltage being switched on to the stator windings. A typical connection diagram is shown in Fig. 8. The rotor resistances are cut out gradually in much the same manner as the starting resistances of a D.C. motor. Either metallic or liquid rheostats may be used according to circumstances and starting conditions. Liquid rheostats can be used in the present case because electrolytic effects are practically non-existent with alternating currents. Moreover, the liquid resistance is non-inductive, which is an advantage (see p. 820). Further details of liquid rheostats are given later.

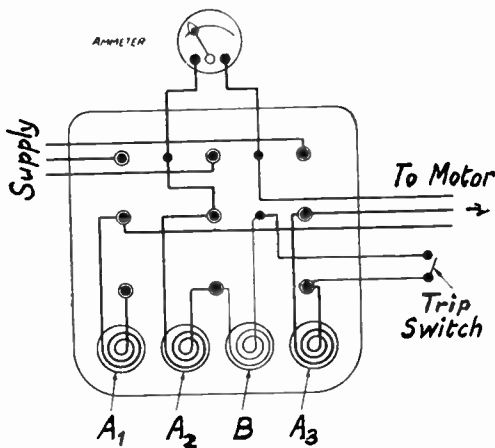

Fig. 11.—CONNECTIONS OF ELLISON DIRECT STARTER.

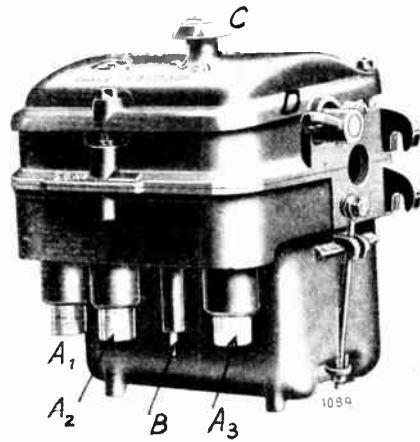

Fig. 10.—DIRECT STARTER WITH TIME-LAG SOLENOID RELEASES. (George Ellison.)

$A_1, A_2, A_3$ , over-current releases; B, under-voltage release; C, tripping press button; D, operating handle.

### Starting Current and Starting Torque of Three-phase Motors with Rotor Resistance Starter.

The starting conditions—in so far as starting current and torque are concerned—with a *rotor* starter are quite different from those with a *stator* starter, as in the former case full voltage is applied to the motor. Therefore the starting torque is dependent upon both the rotor current and the ratio (reactance/resistance) of the rotor circuits as a whole. The relationship between these quantities is best shown graphically, and Fig. 9 is representative of a typical motor.

The maximum starting torque is obtained when the resistance of the rotor circuits as a whole is equal to the starting reactance of these circuits. Under these conditions the starting torque may be from 2.3 to 3.2 times (or more, in special cases) the full-load torque (according to the design of the motor), and the corresponding starting (line) current will be about 2.7 to 3.8 times the full-load current.

If the resistance of the rotor circuit is increased, both the starting torque and the starting current decrease, and, with a suitable value of resistance, full-load starting torque may be obtained with a line current only slightly in excess of full-load current. On the other hand, if the

resistance of the rotor circuit is reduced below the value corresponding to maximum starting torque, the starting (line) current is increased and the torque is reduced. Therefore, the resistances for a rotor starter should always be arranged so that with maximum resistance the stator current is below the value corresponding to maximum torque.

**How Three-phase Variable-speed Commutator (Brush Shifting) Motors are Started.**

These motors may, in certain cases, be started by direct switching, as when the brushes are in the position corresponding

field winding on the rotor is usually short-circuited. When the motor has run up to speed the short circuit across the field winding is removed and D.C. excitation is applied which causes the rotor to lock into synchronism.

*Small synchronous motors* without D.C. excitation are started in the same manner as a squirrel-cage motor of corresponding size, e.g., by direct switching, by star-delta connections, or by using an auto-transformer. The method to be used depends upon the starting torque required.

*Synchronous-induction motors* are started in the same manner as ordinary slip-ring motors, i.e., by means of a rotor rheostat.

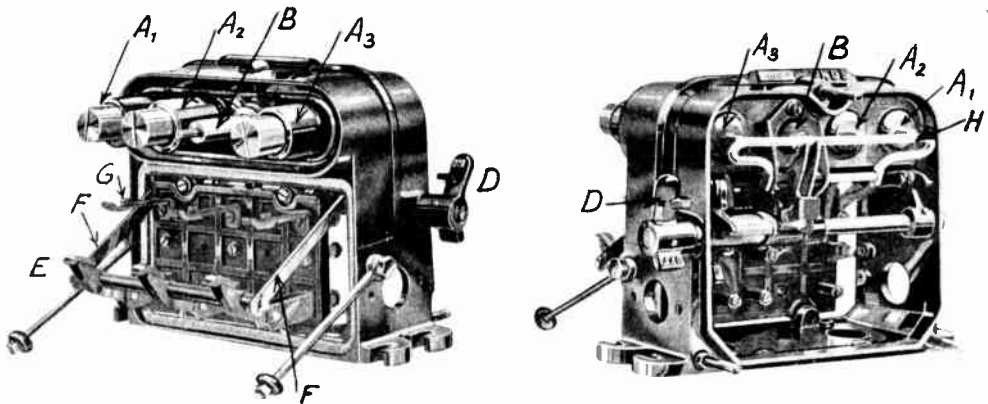

Fig. 12.—INTERNAL VIEWS OF ELLISON DIRECT STARTER.

Left:—View from underside (oil tank removed) showing the switch contacts E, G and the operating links F.

Right:—View from above (cover removed) showing the plungers of the solenoid releases and the tripping bar, H.

to the lowest speed, the starting current is of the order of  $1\frac{1}{2}$  times full-load current and the corresponding torque is nearly twice full-load torque. Hence, except in cases where specially slow starting is required, no special starting gear is necessary. For slow starting resistance is connected in the secondary windings as shown in Fig. 22, p. S29.

**How Three-phase Synchronous and Synchronous-induction Motors are Started.**

*Synchronous motors* having a squirrel-cage winding in the pole faces are started by supplying the stator at reduced voltage by means of an auto-transformer. The

But usually a change-over switch is necessary to disconnect the starter and connect the D.C. exciter to the slip-rings when the machine has run up to speed.

**STARTERS FOR THREE-PHASE MOTORS.**

**Classification.**

Starters for A.C. motors are classified according to : (1) The method of starting ; (2) the method of operation ; (3) the type of rheostat (e.g., metallic or liquid).

Thus, for squirrel-cage motors we have the following types : Direct starters, hand or power (contactor) operated ; star-delta starters, hand or power (contactor)

operated ; auto-transformer starters, hand or power (contactor) operated ; rheostatic (stator) starters, hand-operated, metallic rheostats.

For slip-ring motors the types of rotor starters are as follows : Hand-operated face plate, metallic rheostats ; hand-operated drum controller, metallic rheostats ; contactor, metallic rheostats ; hand-operated liquid rheostat ; power-operated liquid rheostat (automatic).

**Applications.**

The applications of the above starters are summarised in Table II, and further details are given in the following pages under the appropriate section headings.

**TYPES OF DIRECT STARTERS.**

For the direct switching of squirrel-cage motors a special switch or starter with automatic releases should be used rather than an ordinary triple-pole switch, as with the former the motor is fully protected.

The simplest direct starter with automatic features has a drum-type three-position switch with an electro-magnetic catch, which forms a no-voltage release. Ordinary fuses are provided for over-current protection, and they are cut out of circuit when starting.

**Direct Starter and Circuit Breaker with Solenoid Releases and Time Lags.**

Figs. 10, 12 illustrate a hand-operated starter and circuit breaker with under-

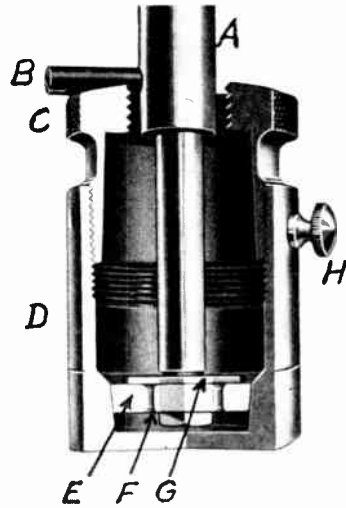

Fig. 13.—TIME-LAG PISTON AND DASHPOT. (George Ellison.)

A, plunger ; B, stop ; C, adjustment for current setting ; D, time-lag dashpot ; E, piston ; F, G, valve ; H, locking screw for time-lag adjustment.

voltage and over-current releases of the solenoid type, and Fig. 11 shows the internal connections. The switch contacts are of the controller finger type, the moving contacts E being operated through linkwork F. These contacts are retained in the closed position by a catch, which is

TABLE III.—DATA OF ORDINARY DASHPOT-TYPE TIME-LAG DEVICE. (Fig. 13.)

Per cent. of over-current on setting of plunger ..	10	25	50	75	100	150	200
Time delay (seconds) with piston setting No. 8 and light engine oil, 60° F. (Grade D.T.E., Vacuum Oil Co.) ..	36	18.5	9.0	5.5	4.0	3.0	2.5
Do. do. and switch oil (as used in oil switches), 60° F. ..	18	9.2	4.5	2.7	2.0	1.5	1.2
Do. do. and heavy engine oil, 60° F. ..	120	61	30	18	13.2	10	8.3
Do. do. and extra heavy engine oil, 60°F.	330	170	83	51	37	28	23

Time ratios, relative to No. 8 setting, for other settings Nos. 1-11 of piston in dashpot.

Setting No. ..	1	2	3	4	5	6	7	8	9	10	11
Time ratio ..	0.085	0.2	0.27	0.34	0.55	0.63	0.84	1.0	1.14	1.37	1.5

tripped either manually, by pressing the button C on the cover, or electrically, by the plungers of the over-current and under-voltage solenoids. The plungers of the over-current solenoids are fitted with time-lag pistons and oil dashpots to give a time lag or delay to the action of these releases during starting and on the occurrence of overloads.

**Principle and Details of the Time-lag Device.**

The principle of the dashpot type of time-lag depends upon the resistance offered by a small orifice to the flow of a viscous liquid, such as thick oil or glycerine. This principle is applied to overcurrent solenoid-type releases by fitting to the plunger an extension which carries a piston normally immersed in a cylinder or dashpot containing a small quantity of thick oil. The piston has a small clearance in the cylinder, and both piston and cylinder bore are slightly tapered in order that the clearance may be adjusted by raising or lowering the cylinder relative to the piston. Fig. 13 shows the general arrangement. Hence as the time required to raise the piston when a given upward pull is applied to the plunger depends upon the re-

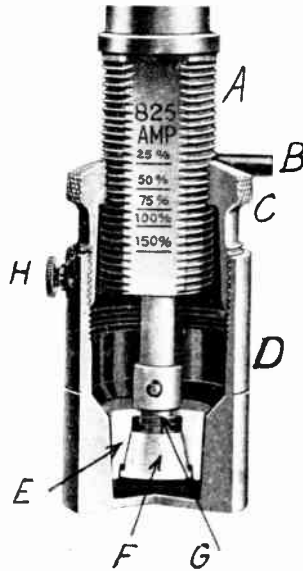

Fig. 14.—TIME-LAG PISTON AND DASHPOT. (George Ellison).  
A, calibration tube, enclosing plunger; B, stop; C, adjustment for current setting; D, time-lag dashpot; E, piston; F, G, valve and spring; H, locking screw for time-lag adjustment.

sistance to the flow of oil through the clearance space, the time-lag is diminished by increasing the clearance (i.e., by lowering the cylinder relative to the piston) and increased by decreasing the clearance. Typical time-lag curves have already been given in the article on *Distribution Switchgear*, p. 862, and Table III gives additional data appropriate to the time-lag device illustrated in Fig. 13.

The body of the piston is fitted with a valve, which is normally closed, and remains closed when an upward pull is applied to the plunger, but opens when the plunger is released, and so allows the plunger and piston to return to their normal positions with the minimum delay.

**Double-valve Time-Lag Device.**

The above type of time-lag device, although used extensively on ordinary circuit breakers, is unsuitable for the direct starter type of circuit breaker, as if it is adjusted to give sufficient time-lag for the heavy starting currents, the time-lag with ordinary overloads will be excessive, and, therefore, the protective qualities of the device will be affected. This disadvantage has been overcome by fitting the piston

TABLE IV.—DATA OF DASHPOT TIME-LAG DEVICE WITH DOUBLE-VALVE PISTON. (Fig. 14.)

Per cent. of over-current on setting of plunger	25	50	100	125	150	200	300	400	500	600	1,000
Time delay (seconds) with piston setting No. 6 and medium engine oil ("BB" grade) at 72° F.	20	10	7	3.3	3.3	2.2	1.3	8	7	5	3.5
Time ratios, relative to No. 6 setting, for other settings Nos. 1-8 of piston in dashpot.											
Setting No.	1	2	3	4	5	6	7	8			
Time ratio	0.1	0.21	0.3	0.4	0.66	1.0	1.7	2.7			

with a double valve, as shown in the sectioned view of Fig. 14. The inner portion of the piston is in the form of a truncated cone and is attached to the plunger extension rod. The outer portion of the piston normally rests upon a spring, which maintains a slight clearance between the inner and outer portions. This clearance is additional to that between the piston and dashpot.

If a light upward pull, insufficient to close the spring, is applied, both clearance spaces (inner and outer) are effective and the time delay is relatively short. But if a heavy pull, due to the starting current of a motor, is applied, the inner clearance space closes and the time delay is increased. Thus, although the delay with normal overloads is the same as that obtained with the ordinary time-lag (Fig. 13), an increased delay is obtained at starting, and the motor is able to start and accelerate to full speed without tripping the circuit

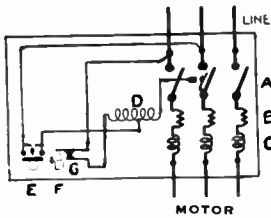

Fig. 16.—CONNECTIONS OF B.T.-H. ELECTROMAGNETIC STARTER AND CIRCUIT BREAKER.

A, main contacts; B, heating elements of thermal relays; C, electromagnetic releases; D, coil of operating magnet; E, "on" push button; F, "off" push button; G, contacts of "off" switch.

The starter and circuit-breaker illustrated in Fig. 10 is capable of carrying 15 amperes continuously, and accordingly it should be used with motors having full-load currents not greater than 0.8 of this value, i.e., 12 amperes, in order that over-

breaker. With short circuit conditions, however, practically instantaneous tripping is obtained.

Typical time lag characteristics for the double-valve piston illustrated in Fig. 14 are given in Table IV.

**Applications.**

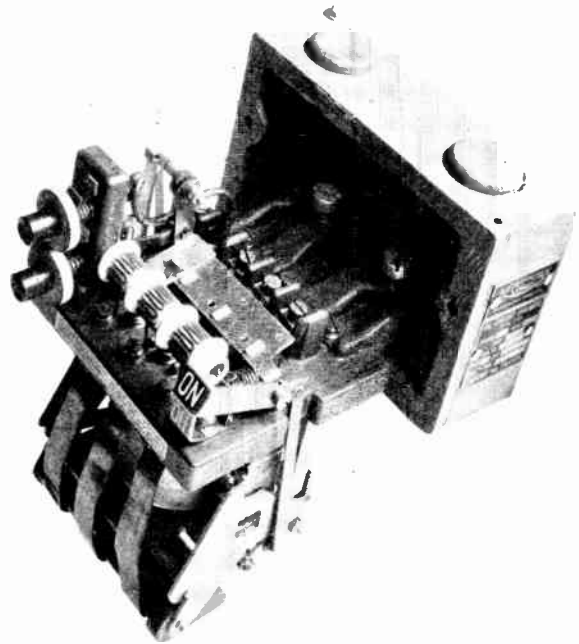

Fig. 15.—INTERNAL VIEW OF ELECTROMAGNETIC DIRECT STARTER AND CIRCUIT BREAKER. (B.T.-H. Co.) This view shows the push buttons (left), the "on" "off" indicator (right), the heaters for the thermal relay, and the tripping bar. An external view is shown in Fig. 19.

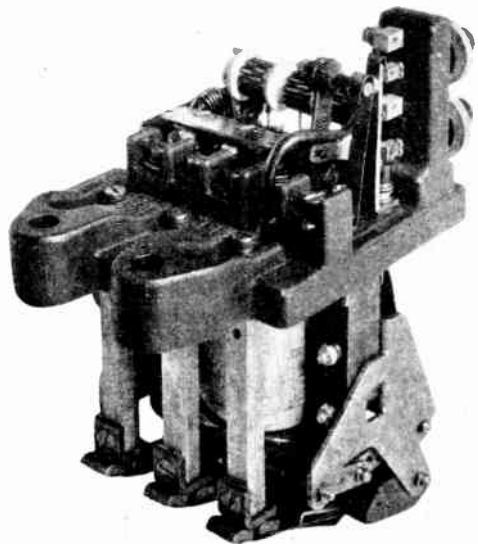

Fig. 17.—ANOTHER INTERNAL VIEW OF ELECTROMAGNETIC DIRECT STARTER AND CIRCUIT BREAKER. (B.T.-H. Co.) This view shows the main contacts, the operating magnet, the main terminals, the tripping bar and the contacts of the push buttons.

E D

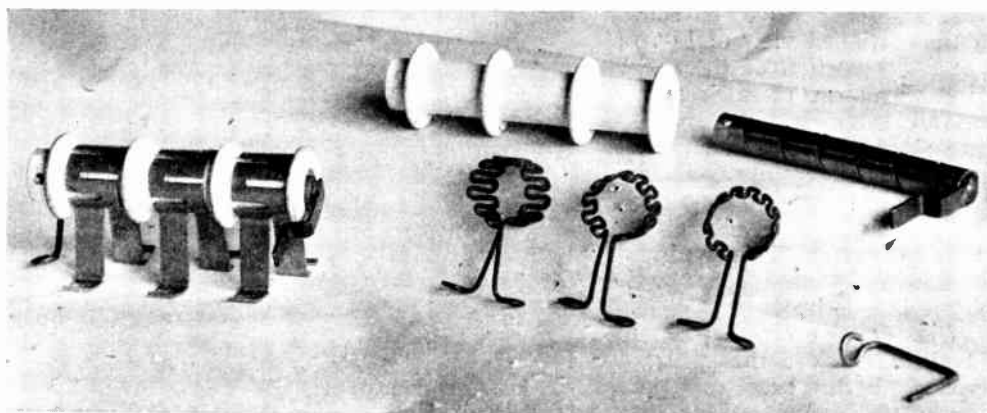

Fig. 18.— THE THERMAL RELAY AND ITS COMPONENT PARTS. (B.T.-II, Co.)

On the left (A) is shown the relay completely assembled, and on the right are shown the parts, viz., the heating element (B), the steatite tube (E), the bi-metallic spiral (D), and the anchoring pin (C). This form of the thermal relay is used for the larger current ratings (20-30 amps.). For the smaller current ratings separate bi-metallic strips directly heated are used as shown in Fig. 19.

heating may not occur when the motor is carrying 25 per cent. overload. Suitably wound coils for the over-current releases are available for lower currents.

**Direct Starter and Circuit-breaker with Thermal Relays.**

Figs. 15, 17 illustrate a novel type of electro-magnetic direct starter with push-button control (direct or remote) and thermal relays for over-current protection. The switch contacts are oil immersed and are operated by a single-phase electro-magnet. Fig. 16 shows the scheme of connections. Thin lines represent the control circuits, and thick lines represent the main circuits.

The switch is closed by momentarily pressing the "on" push-button E, Fig. 16, which operation connects a portion of the operating coil of the electro-magnet across two of the supply mains. Just before the main contacts close, an auxiliary switch connects the whole of the winding of the operating coil to the supply independently of the "on" push-button.

The object of using only a portion of the

coil for closing the switch is to obtain sufficient pull to give a rapid closing action. When once the switch has closed a much smaller pull is sufficient to retain it in the closed position, and therefore the current in the operating coil is reduced by cutting in more turns of the winding.

The switch is opened by interrupting the circuit of the operating coil. This operation may be effected either manually, by pressing the "off" push-button F, Fig. 16, or automatically, by the action of the over-current releases. The switch also opens automatically in the event of a failure of the supply or of an abnormally low voltage. In these cases the operating electro-magnet acts as an under-voltage release.

**The Thermal Over-current Relay.**

Over-current protection and delayed action of the over-current releases is obtained by thermal relays. These relays can be seen in Fig. 15 between the push-buttons and the "on"-"off" indicator, and details are shown in Fig. 18. The essential parts are (1) three heating elements (B, Fig. 18), one in each supply line,

TABLE V. TIME LAG CHARACTERISTIC OF THERMAL RELAY. (Fig. 18).

Per cent. of normal full-load current ..	125	150	200	300	400	500	800
Time to trip (seconds) .. .. .	infinite	500	240	125	80	55	30



(2) a bi-metallic spiral, which when sufficiently heated untwists and operates a tripping bar which opens the contacts of the "off" push-button switch, G, Fig. 16. The tripping bar can be seen in Fig. 15; it is located between the heaters and the main terminals.

The heating elements are wound on the exterior of a steatite tube. The bimetallic spiral is made from a strip of bimetel (which consists of two dissimilar metals, having widely different coefficients of expansion, welded together), the material having the higher expansion being on the outside, so that the spiral untwists under the action of heat. This spiral occupies the interior of the steatite tube; one end is anchored to the tube, and the other end is fitted with a lever which engages with the tripping bar previously referred to.

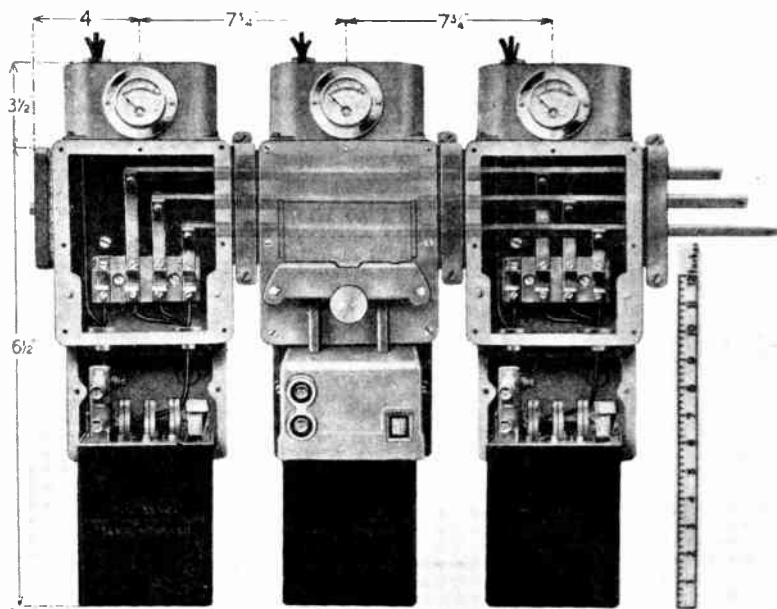

Fig. 19.—GROUP OF B.T.-H. ELECTROMAGNETIC STARTERS AND CIRCUIT BREAKERS.

This view shows the bus-bars, bus-bar chambers and isolating plugs. The covers have been removed from the two end circuit breakers, and a phantom cover is shown over the bus-bar chamber of the middle circuit breaker.

The bimetallic spiral is therefore heated by the joint effects of the main currents; the heat received by the spiral during a given time being proportional to the square of the current. As the rate at which the spiral untwists is proportional to the heat received, the time required to trip the contacts of the "off" push-button switch is inversely proportional to the square of the currents in the heater elements.

The bimetallic spiral is therefore heated by the joint effects of the main currents; the heat received by the spiral during a given time being proportional to the square of the current. As the rate at which the spiral untwists is proportional to the heat received, the time required to trip the contacts of the "off" push-button switch is inversely proportional to the square of the currents in the heater elements.

**How the Time-lag is Obtained.**

The time-lag is obtained by the indirect method of heating the bimetallic spiral, the latter being separated from the heaters by the steatite tube and the air space between the spiral and the inside

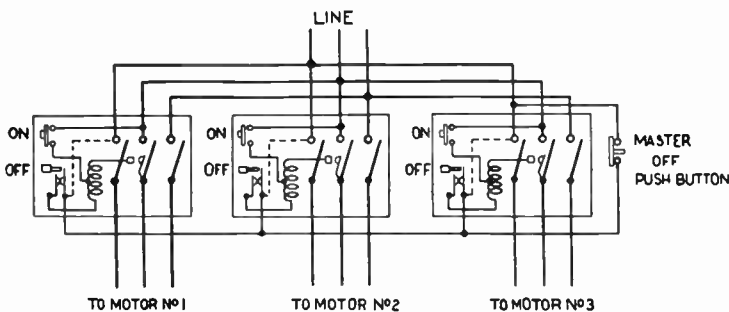

Fig. 20.—CONNECTIONS OF A GROUP OF B.T.-H. ELECTROMAGNETIC STARTERS AND CIRCUIT BREAKERS WITH MASTER "OFF" PUSH BUTTON.

Note.—The dotted lines indicate internal connections which must be removed when installing the breakers.

of the tube. This heat produced by the currents in the heaters is not received immediately by the spiral, and in consequence a time delay occurs between the application of an over-current to the heaters and the tripping of the switch. Typical characteristics are given in Table V.

These characteristics are similar to the heating characteristics of continuously loaded motors and therefore this thermal

relays in excess of 10 times the rated current of the starter. An electro-magnet is connected in series with each heater, as shown at C in the connection diagram of Fig. 16, and the common armature forms the tripping bar already referred to.

### Applications.

The electro-magnetic starter illustrated in Figs. 15, 16 is capable of handling momentary starting currents of 100 amperes, and heater

elements are available for carrying continuously currents up to 30 amperes. The full-load current of the motor should correspond to 0.8 of the rated current of the heater elements, in order that these elements shall not become overheated when the motor is operating at 25 per cent. overload, which all motors built to British Standard specifications are capable of withstanding for periods of from 15 minutes to two hours, according to size.

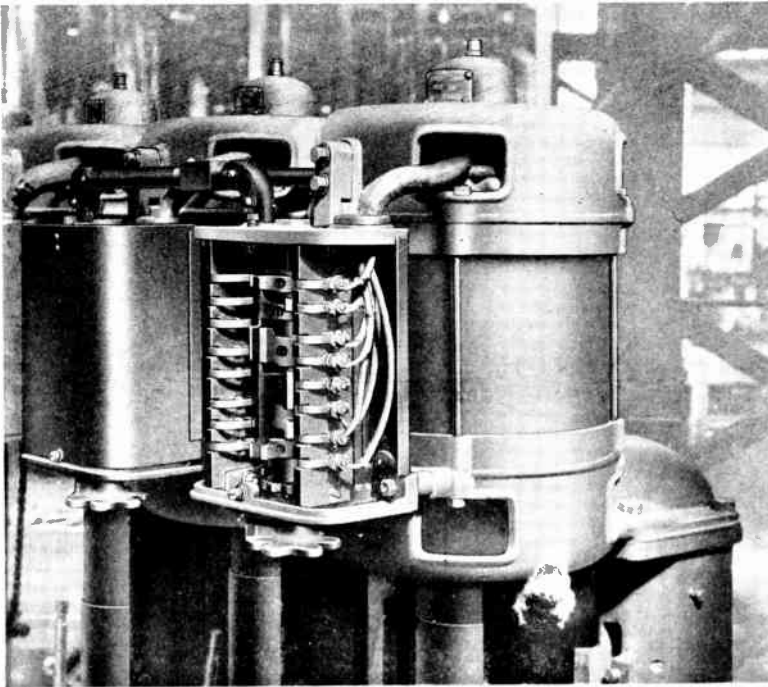

Fig. 21.—CONTROLLER-TYPE DIRECT STARTER FOR FOUR-SPEED MOTOR. (B. T. H. Co.)

Close-up view showing starters mounted on frames of 2-h.p. four-speed motors of multiple-spindle drilling machine illustrated in Fig. 15, page 825

relay gives ideal protection against over-currents.

### Thermal Relays Require Protection Against Excessive Currents.

Thermal relays are liable to be damaged by short-circuit currents owing to the time interval required for the heat produced by currents in the heater to reach the bi-metallic spiral. In the above starter an electro-magnetic release is fitted which gives instantaneous tripping for all cur-

rents in excess of 10 times the rated current of the starter. An electro-magnet is connected in series with each heater, as shown at C in the connection diagram of Fig. 16, and the common armature forms the tripping bar already referred to.

When a number of small motors grouped together are to be controlled, the starters may be grouped together as illustrated in Fig. 19. In this case the starters are interconnected by bus-bars, and isolating contact plugs are fitted to enable any starter to be isolated from the bus-bars. Fig. 20 shows a diagram of the connections in which a master "off" push-button is included for simultaneously opening the whole group of starters from a remote point; while each starter can be controlled individually.

## The Weekly for Everyone with a Hobby

"HOBBIES" deals with every practical hobby and handcraft and makes a special feature of the latest developments in Wireless. Every issue contains numerous illustrations which explain how to make such varied articles as Model Aeroplanes and Gliders, Electric Motors, Model Trains, Wireless Sets, pieces of Furniture, Musical Instruments. There are pages for the stamp collector, amateur photographer and collector. Articles on how to do things, how to solder and french polish, do your own printing, how to work in wood, metal, etc.

THE free advice bureau unravels readers' problems in all practical hobbies. The pages are packed with practical and informative matter prepared by expert contributors and artists. Competitions with hundreds of prizes regularly appear.

ALL the features in "Hobbies" are new, and the matter is prepared so that the various articles can be made with a minimum of expense and without an elaborate tool-kit.

# Hobbies

and Practical Wireless

Every Wednesday

Twopence

On sale at all Newsagents and Bookstalls, or post free, 3d. (6 months 6/6) from George Newnes, Ltd., 8-11, Southampton Street, Strand, London, W.C.2.

Geo. Newnes, Ltd.

# THE BEST PRACTICAL ADVICE ON

## CARPENTRY AND CABINET MAKING

An Illustrated Handbook for the Amateur, with numerous Drawings and Designs.

By W. M. OAKWOOD.

Cloth. Price 1s. 6d., post free 1s. 9d.

This handbook contains a description of the tools most generally used, with instructions how to use them. The choice of woods for various purposes—Fretwork as applied to cabinet-making—A chapter on french polishing, staining and varnishing

## METAL WORK

By GEORGE DAY, F.R.M.S.

Cloth. Price 1s. 6d., post free 1s. 9d.

A Practical Handbook for the Amateur Worker in Iron, Brass, Zinc, Copper, etc. With numerous Illustrations and Designs.

Some of the 10 Chapters are—Tools required for Metal-work—General Methods of Copying the Pattern, Drawing and Transferring—General Methods of Working—To Etch on Metals—Fretworking in Metals—Useful Recipes for Metals and Metal Workers, etc.

## WOOD CARVING

A Practical Guide for the Home Student.

By J. H. GARNETT.

With numerous Illustrations and Designs.

Cloth. Price 1s. 6d., post free 1s. 9d.

contains in addition to full instruction on the practice of the Art of Wood Carving—Chapters on Choice of Woods, Tools, Designs, Appliances, etc., Chip or Notch Carving, Staining, Polishing, Gilding, Painting, etc.

On sale at all booksellers, or may be had or post free prices direct from The Book Publisher, PEARSON'S Book Dept., 15, Henrietta Street, London, W.C.2.

This article on Starters and Control Gear for A.C. Industrial Motors is continued in Part 28. Ready April 22nd. Order your copy to-day,

# Good Reading For Everybody!

## PEARSON'S MAGAZINE

EVERY MONTH - - 1/-

There is no magazine on the market that quite equals *Pearson's Magazine*. For the business man it is an ideal relaxation, for the fiction lover a never ending source of the best stories, for the serious reader a reference work of helpful and instructive articles.



## THE NOVEL MAGAZINE

EVERY MONTH - - 9d.

There is never a dull page in *The Novel Magazine*. Each month it contains complete stories of wit, humour, adventure, love and sentiment, by distinguished writers—stories to suit every taste. It is the ideal companion for train, tube or fireside. Every number of *The Novel* is the best!



## HOME GARDENING

PRICE 2d. WEEKLY

*Home Gardening* is the amateur gardener's paper. Every week it is packed with just the kind of information you need, to have your garden looking good all the year round and to grow the finest flowers, vegetables and fruit. Show-you-how-to-do-it photos and garden planning suggestions prepared by a famous garden architect are a special feature.

## THE NEW ROYAL MAGAZINE

EVERY MONTH - - 6d.

*The New Royal*, although only sixpence in price, is quite definitely a shilling magazine in value. Each number is packed from cover to cover with excellent complete stories by the best-known authors, interesting articles on all up-to-date topics, attractive illustrations and other features. A special 16-page *Film Album* appears each month, part of which is devoted to signed portraits of popular celebrities. There is something to interest everyone in *The New Royal*—in fact, the whole of it will.



## PEARSON'S WEEKLY

PRICE 2d. WEEKLY

Popular articles on topical subjects in *Pearson's Weekly* are written by world leading authorities. Interviews with famous people, "behind the scenes" disclosures, real life stories, and fiction with a strong human interest combine a weekly budget of reading matter appealing to readers of every class. Hundreds of pounds given away every week in Simple Competitions.



## THE SMALLHOLDER

PRICE 2d. WEEKLY

Every week *The Smallholder* is full of suggestions for all who would save money with home-grown produce. It not only tells you what to do but how to do it, by simple action photographs.