

Low Voltage Luminous Tube Lamps

The **PRACTICAL**

ELECTRICAL ENGINEER

A MONTHLY MAGAZINE OF ELECTRICAL PROGRESS



VOL. 1.—No. 10

JUNE, 1933

ELECTROLYTIC BATTERY CHARGER

*Full instructions for making
given in this issue*

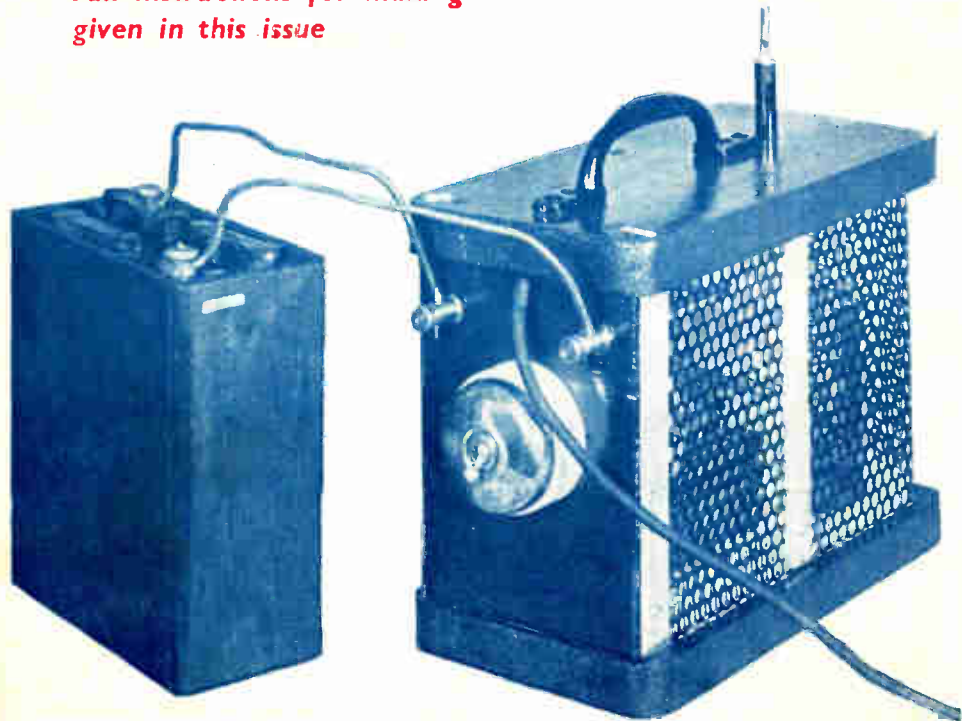

GEORGE NEWNES LTD.



**PAY
LESS**

FOR YOUR POWER

—quality for substantial rebates on Power Factor improvement

DO you pay idle workers? You do not! Then why pay for idle current, which is even more wasteful? Immediately the T.C.C. Power Factor Correction Equipment is installed, the power factor is improved; that idle current is turned to cash—the supply company's bonus quickly pays for the equipment itself. Then it is clear profit. May we show you how? Our catalogue will explain—let us send you a copy. Or even better, put your particular problem before us—our unique experience is freely at your disposal.

IF YOU ARE NOT GETTING YOUR BONUS SEND FOR INFORMATIVE CATALOGUE No.61

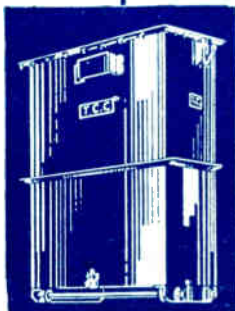

T.C.C.
STATIC POWER CONDENSERS

THE TELEGRAPH CONDENSER COMPANY, LTD.

Works: Wals Farm Road, S. Acton, London, W.3
Power Sales Office: Avenue Chambers, Vernon Place, Southampton Row, London, W.C.1
Phone: Holborn 7072 Telegrams: "Condensita, Walsand, London"

♥ 2844



EDISWAN



'The name that means' EXCELLENCE

SIMPLICITY ITSELF!



EDISWAN "CYGNET" SWITCH

QUICK MAKE & BREAK
MOULDED BASE & COVER
POSITIVE ACTION

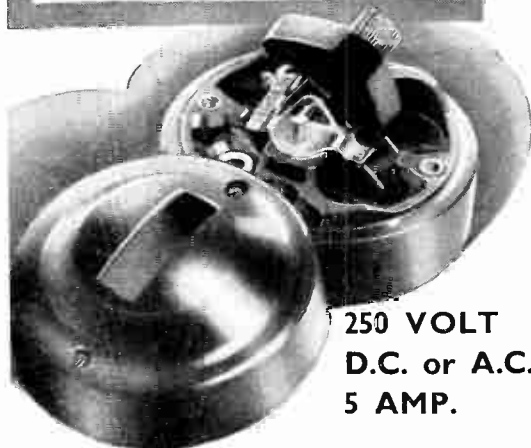

**250 VOLT
D.C. or A.C.
5 AMP.**

This new switch offers a number of advantages to both contractor and user. All external parts are moulded from the highest quality insulating material. The action is rapid, positive and has been reduced by the designer to the limit of simplicity. But it is in actual service that this switch reveals its biggest advantages. The slotted

cover is dustproof and, in the unlikely event of the dolly breaking, no live parts are exposed. It is small and neat in appearance yet exceedingly robust. It not only complies with I.E.E. regulations but has an ample margin in excess of these requirements.

Send for folder A.8.40 which gives full particulars.

EDISWAN MOULDED ACCESSORIES



THE EDISON SWAN ELECTRIC CO. LTD., 155 CHARING CROSS ROAD, W.C.2

Bring your lighting problems to **EDISWAN**

L.A.158

MM



SINGLE-PHASE MOTORS

FOR EVERY APPLICATION



*Ratings from the
smallest Fractional
Horse-power upwards*

*Types to suit all ratings and starting conditions
and STARTERS specially designed to give best results*

BTH RUGBY

THE BRITISH THOMSON-HOUSTON COMPANY, LIMITED, RUGBY, ENGLAND

A1086

The PRACTICAL ELECTRICAL ENGINEER

A MONTHLY SURVEY OF MODERN PRACTICE IN ELECTRICAL ENGINEERING

VOL. I

JUNE, 1933

No. 10

Published by GEORGE NEWNES, Ltd.,
8-11, Southampton Street, Strand, London W.C. 2.

Telephone—Temple Bar 7760

Telegrams—"Newnes, Rand, London"

Price - 1/- Monthly

Yearly Subscription, 14/- Post Free
6 months' Subscription, 7/- Post Free

Registered for Transmission by Canadian Magazine Post
Canadian Rate: Yearly Subscription, 13/6 Post Free
6 months' Subscription 6/9

Lamp Sales.

The recent formation of the Crompton Kye Lamp Sales Organisation under which the two largest non-ring lamp manufacturers have pooled their resources is an interesting development. The organisers claim that their programme for the coming season is the most ambitious individual scheme ever planned to co-operate with the recognised electrical wholesalers and retailers profitably to combat the menace of cheap imported lamps.

Electrical Advertising.

This opens up the very interesting question of electrical advertising. So long as electrical manufacturers were only concerned with selling their products to engineers the problem of advertising was comparatively simple. The time is now approaching when, in order to take full advantage of the possibilities of electrical development, some of our larger manufacturers must consider seriously the question of advertising their goods direct to the public. The electrical retailer cannot be expected to educate the public to the full possibilities of the many domestic electrical appliances which are now available. At the present time the great majority of people who are not in the industry seldom think electrically, except, perhaps, at Christmas time when they may purchase toasters, hair dryers, and similar electrical appliances suitable for presenting to their friends.

A few years ago, electrical advertising direct to the public would not have been a worth-while proposition, but to-day there is an immense amount of new business to be secured in this way. The possibilities of multiple switching for landings, passages

and outhouses, dimming switches, low candle power lamps for bedroom and landing nightlights, electrical refrigerators, fans, hair-dryers, irons with thermostat control, safety electric kettles, heated towel rails, are a few electrical items which have infinitely more interest to the housewife than to the electrical retailer so far as advertising is concerned.

The Four Cardinal Points.

The woman, who decides in most cases how money is to be spent in connection with the home, has to be shown by skilful advertising *the convenience, the safety, the simplicity, and the economy* of using the many domestic electrical appliances which are now available. Whilst advertising to other engineers will continue to be the most effective form of publicity for manufacturers of highly specialised electrical products and for the producers of the raw material of electrical manufacture, the same will not apply in the case of those firms who depend for their prosperity upon the sale of domestic electric appliances. Before the recent Russian trial, how many people outside the electrical industry knew of the existence of the great firm of Metro-Vickers? True Metro-Vickers may not have much to sell direct to the general public, except through their associated companies, but the fact remains that before the trial there were literally millions of people in the country who had never heard of their existence.

The Lesson of the Wireless Industry.

Wireless manufacturers quickly realised that advertising to other wireless engineers and manufacturers would not get them very far, and results achieved in the wireless field have

proved there is an immense scope for those electrical manufacturers who apply similar methods to bringing the advantages of their products prominently before the woman in the home.

The above remarks may at first appear to be outside the scope of a technical magazine, but this is not so. The function of the magazine is to serve the interests of its readers, practically all of whom are in one or other branch of the electrical industry. Increased prosperity in the electrical industry means increased prospects for every reader of these pages.

A Low Voltage Gas Discharge Lamp.

In this issue we give particulars of a new type of gas discharge lamp which is now in use on a section of the Watford Road, Wembley. The construction and operation of these lamps is extremely simple. They give a light which has a reasonably well balanced spectrum, and are extremely effective for the lighting of main roads. In addition to the absence of glare, an even illumination of the road surface can be obtained by the use of suitable reflectors.

Developed Wiring Diagrams.

The tracing out of circuits and sub-circuits on the diagrams of modern electrical machinery is an involved and difficult process. The method of using developed wiring diagrams which is explained in this issue by Mr. C. J. O. Garrard is well worth study by every reader who may have occasion to deal with circuits of electrical machinery either on the design, installation, or maintenance side.

Public Address Systems.

Many large halls are already equipped with public address systems. The resultant gain in comfort on the part of the audience has to be experienced to be realised. We hope very shortly to publish an article dealing fully with the practical side of the installation of such a system in large and small halls. This is work which should definitely be in the hands of electrical engineers, and there are still hundreds of halls and lecture rooms which are not adequately equipped. In the present issue, we include an article dealing with the construction of a powerful gramophone amplifier suitable for installing in dance halls and small concert halls.

Electrical Relays.

On page 453 will be found an article dealing with the design and construction

of electrical relays of various types. The possibilities of using electrical relays for the remote control of electrical apparatus and for obtaining the required sequence of operation has, we believe, never yet been fully explored. We invite our readers to send in ideas as to the various methods by which relays can be utilised either in connection with electrical models, remote switching, for interlocking devices, etc. A selection of the best suggestions received will be published in a later issue.

Calculating Cable Sizes.

An ingenious appliance for calculating the correct sizes of cables for house and factory wiring is described on page 459. Readers will, we believe, find this more convenient to use than the regulation wiring tables. The scales of the calculator are based on the wiring tables, and the calculator provides a rapid method of calculating and checking sizes.

Electricity in the Garage.

Apropos of our last month's notes—we have received from Mr. A. W. Robertson, A.M.I.E.E., particulars of an immersion heater designed for insertion in the drain plug of a car radiator to keep the water at about 20° above the atmosphere. The unit in question consumes 80 watts, and in order to be effective must be left in action during the night.

Electric Automobiles—So Near and Yet so Far.

Battery-driven electric vehicles have, of course, been in use for over 20 years, chiefly for delivery vans operating within a small radius, for dust and refuse collector carts, and in a few cases for town runabouts. If the problem of producing a storage battery reasonably light and with a large capacity could be solved, there would be an immense scope for electrically driven vehicles amongst private owners. Under modern conditions it would be quite practicable for a private owner to leave his car on charge over night and so store up sufficient energy to propel it for perhaps 50 or 100 miles during the following day at a cost of half a crown or less for electrical energy.

A Subsidy Waiting.

Incidentally, the tax on electrically propelled vehicles is at present £6 irrespective of horse-power—in effect, a subsidy on electric vehicles.

THE LOW VOLTAGE ELECTRIC DISCHARGE LAMP

ITS PRINCIPLE, CHARACTERISTICS AND CONSTRUCTION



Fig. 1.—A SECTION OF THE WATFORD ROAD, WEMBLEY, MIDDLESEX, ILLUMINATED WITH OSIRA ELECTRIC DISCHARGE LAMPS.

ONE of the most important recent advances in the technique of light production is the development and practical application of the electric discharge lamp. An application of this type of lamp to indoor illumination was referred to in the March issue, on page 298. Another application is the installation by the General Electric Company of their "Osira" lamps, to the lighting of a mile of the Watford Road, Wembley, Middlesex, as shown in Fig. 1. An extremely interesting feature of this installation is that the lamps are installed under the normal street lighting conditions of wiring and switching, and at usual spacings and mounting heights. The cost of running such lamps is stated to be considerably lower than ordinary filament lamps of equal capacity.

The New Principle Explained.

The electric discharge lamp introduces into practical use an entirely new source of light.

In the past, all practical illuminants have depended upon the radiation emitted from heated solids. The sun, the filament of an electric lamp, the gas mantle and the crater of a carbon arc all emit light because and only because, they are extremely hot.

The case of electric discharge lamps is, on the other hand, entirely different. The light is produced, not because the gas or vapour is very hot, but because it is "excited" electrically. Energy is acquired by the individual atoms owing to their collisions with ions and electrons and the atoms then release this energy in the form of light.

Briefly stated, the new lamp gives its

light by the discharge of electricity through a mixture of gases which includes mercury vapour.

Construction.

The construction of the new lamp is shown in Fig. 4. It consists of two electrodes situated at opposite ends of a tubular bulb which is enclosed in a vacuum jacket. There are only two leads taken into the lamp, one to each electrode, and connection is made with the supply mains by a standard Goliath Edison screw cap such as is standard on all large gas-filled filament lamps.

Connections.

The "Osira" electric discharge lamp is

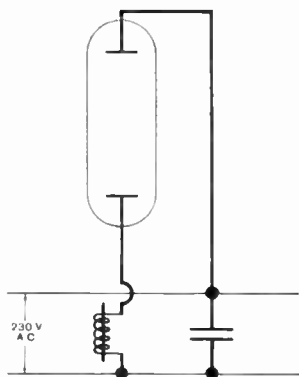

Fig. 2.—THE COMPLETE WIRING SYSTEM FOR THE "OSIRA" ELECTRIC DISCHARGE LAMP.

connected directly to a standard A.C. supply through a simple choke and will start automatically when switched on. No gear is needed for starting the discharge, nor are any filament transformers required to heat the electrodes (see Fig. 2).

All discharge lamps have a characteristic similar to that of an arc, and therefore require a series impedance. On A.C. supplies this can be introduced by a choke without appreciable loss of energy, but when used on D.C. supplies, there is the inherent disadvantage that a resistance must be used. This will absorb consider-

able energy and lower the overall efficiency as compared with that of a lamp designed for A.C. working. It will thus be seen that in all considerations of discharge lamp efficiency, it is most important to distinguish between the energy consumed by the lamps themselves and by the complete installation.

As the current through the lamp is not strictly sinusoidal, the usual simple methods of calculating power-factor from a knowledge of the inductance and capacity in the circuit do not accurately hold.

The use of a series choke on A.C. supplies will lower the power-factor of the system and under commercial conditions it may be necessary to correct it. In an indoor installation this might be effected at a

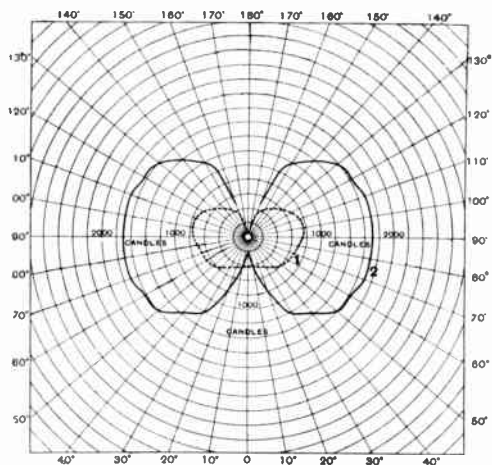

Fig. 3.—LIGHT DISTRIBUTION CURVES IN A VERTICAL PLANE OF ORDINARY LAMP AND ELECTRIC DISCHARGE LAMP.

Curve 1, Osram 500-watt gas-filled Tungsten filament lamp. Curve 2, "Osira" 420-watt electric discharge lamp.

central point, but in an outdoor installation it will be desirable to keep the current in the distribution cables as low as possible by fitting a condenser at each unit. When the new lamp is used on a 50 cycle A.C. supply, a 20 microfarad condenser raises the overall power-factor to the satisfactory value of 0.83. The complete wiring diagram under these conditions is that shown in Fig. 2.

As the new lamps have G.E.S. caps, they

will fit in existing lampholders, and, as they are at present designed to operate directly off existing A.C. supplies of 230/250 volts, it is clear that the only alteration needed when existing filament lamps are to be replaced by the new lamp is the insertion of the choke in one of the lamp leads. In street lighting columns the choke and the condenser (for power-factor correction) may be housed in the base of the standard.

Efficiency and Life.

The most important feature of the new lamp is that its initial efficiency *including the losses in the choke* is 38 lumens per watt as compared with the $15\frac{1}{2}$ lumens per watt given by a tungsten filament gasfilled lamp of similar wattage; that is to say, it has an overall efficiency of $2\frac{1}{2}$ times that of the tungsten filament lamp. The efficiency of the lamp alone is 39 lumens per watt.

The total consumption of the lamp and choke is 420 watts of which 10 are lost in the choke. This wattage was chosen as giving a light output approximately equal to that of a 1,000 watt tungsten filament lamp. The life of the new lamp is at least equal to that of the normal filament type.

Light Distribution.

The distribution of light from the 420 watt Osira electric discharge lamp compared with that of a standard 500 watt Osram gas-filled tungsten filament lamp is shown in Fig. 3. The greatly increased light output will be noted whilst it will be evident to those familiar with the design of street lighting installations that the shape of the polar curve given by the new lamp is particularly useful.

Colour of the Light.

The colour of the light given by a discharge lamp is mainly determined by the gases or metallic vapours with which it is filled.

There have been produced in the G.E.C. Research Laboratories sodium lamps of very high efficiency, but their spectrum consists mainly of two yellow lines very close together. Their light is consequently almost pure yellow and colour discrimination is therefore sacrificed. A picture con-

taining brilliant greens, reds, yellows and blues, appears, under sodium light, as a monochrome in yellow-brown.

With the Osira lamp, a luminous efficiency of $2\frac{1}{2}$ times that of a tungsten filament lamp of similar wattage is obtained, together with reasonably good colour rendering. In its light, blues, greens and yellows appear as brilliant as in daylight.

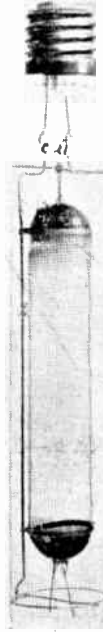

Fig. 4.—THE NEW "OSIRA" LAMP.

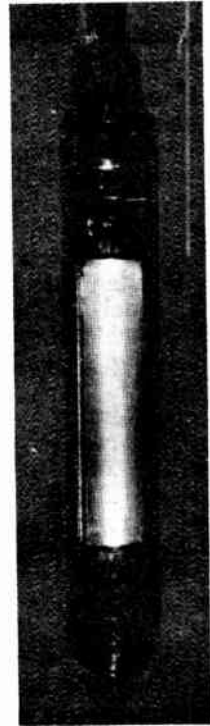

Fig. 5.—THE SOURCE OF LIGHT IN THE NEW LAMP.

Normal Current About 2 Amps.

After the lamp has been switched on, the light output steadily increases for about three minutes. During this time the voltage across the lamp rises and the mains current falls to its normal running value of 2.0 amperes, from an initial value of about three times this figure.

If the supply fails or is switched off, the lamp cannot restart for a few minutes until its temperature has fallen; restarting then takes place automatically.

WOOD POLE CALCULATIONS

By H. E. HUTTER, A.Am.I.E.E.

THE calculation of the stress in a pole stay wire, due either to change in direction of the line or the dead ending of a line, together with the design of the anchor for the stay, can be rapidly obtained from the following data.



Fig. 1.—SHOWING ANGLE BETWEEN WIRES, RESULTING FROM CHANGE IN LINE DIRECTION.

stay attached below the point of pull:—

$$S = \frac{P_1}{\sin \theta} \text{ where}$$

$$P_1 = P \left[1 + \frac{3(H - H_1)}{2H_1} \right]$$

Pull on Pole Stay.

The pull to be taken by the stay due to change in line direction, as shown in Fig. 1, is given by the following table, showing the relation between the angle θ between the wires and the resultant pull in the line, equal to the tension to which the wires are strung \times number of wires.

Angle.	Resultant pull	} $\times P$
160° ..	.348	
140° ..	.684	
130° ..	.846	
120° ..	1.000	
110° ..	1.148	
100° ..	1.286	
90° ..	1.414	
60° ..	1.732	

The stay wire should make as large an angle as possible with the pole, 30-45° being usual.

Position of Stay.

Two positions are suitable for attaching the stay. Let S = tension in stay wire, and P = resultant pull of line wires. First position (Fig. 2A):—

$$S = \frac{P \times bc}{ab}$$

The second case (Fig. 2B) with the

Weight of Earth on Stay Baulks.

The stays are attached to creosoted wood baulks buried in the ground. The stay baulk is held down by the weight of a prismoid of earth resting on it. The weights of the earth prismoids resting on baulks of different sizes buried at varying depths can be read directly from the curve (Fig. 3).

The angle of repose of dry loam is assumed at 30° for the curve; actually it is nearer 45°, providing a suitable factor of safety, the weight of dry loam being 100 lb. per cub. ft.

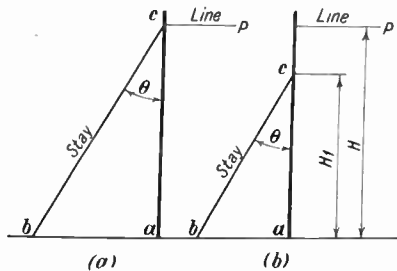

Fig. 2.—TWO POSITIONS FOR ATTACHING STAY WIRE.

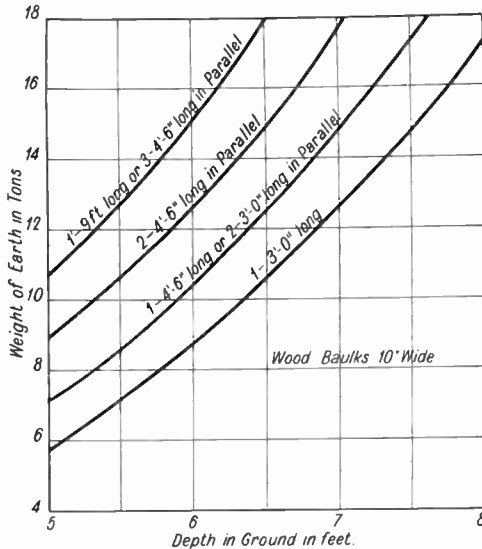

Fig. 3.—CURVES GIVING WEIGHTS OF EARTH RESTING ON STAY BAULKS OF DIFFERENT SIZES.

Stay Wire.

The material used for stay wires is galvanized steel strand of 45 tons per sq. in. breaking strain. A steel stay rod with bow is attached to baulk, the tensioning of the stay being carried out by means of the nut attached to the bow.

Breaking loads of the stay rods are:—

- $\frac{5}{8}$ in. diam. 10,650 lb.
- $\frac{3}{4}$ in. diam. 15,900 lb.
- $\frac{7}{8}$ in. diam. 21,900 lb.
- 1 in. diam. 29,100 lb.

DEVELOPED WIRING DIAGRAMS

By C. J. O. GARRARD, M.Sc.

DEVELOPED wiring diagrams, or, as they are called in the U.S.A., "line to line" diagrams, are an extremely useful aid to the study of automatic contactor equipments, traction work, interlocking schemes, and so on, and should be more widely used than they are. For those who are not familiar with the method, these remarks may be useful.

What a Developed Wiring Diagram is.

A developed wiring diagram is one in which no attempt is made to represent the parts of the various pieces of apparatus, switches, relays, etc., as they actually are arranged, but one in which each separate circuit is represented as far as possible by a straight line running across the diagram between the +ve and -ve poles or between two phases of an A.C. system, which are represented by two vertical lines one on each side of the diagram.

The connections which really run backwards and forwards in all directions between the various pieces of apparatus are straightened out so that they can be represented by straight lines.

How the Diagrams are Constructed.

In the following pages are given one or two examples of developed diagrams with the corresponding wiring diagrams from which they are derived.

In Fig. 1 are shown some of the conventional signs used to indicate various pieces of apparatus when constructing a developed wiring diagram.

A Simple Example.

Fig. 2 is the wiring diagram of a contactor starter for a small three-phase motor (M). This consists of a three-phase contactor (L) with one auxiliary contact.

This contactor can be opened or closed by means of two sets of push-buttons (C). The motor is protected by three overload trips (H) which open the contactor in case of the motor being overloaded.

Fig. 3 is the corresponding developed diagram. This is in two parts, one representing the main connections which carry the motor current, and the other showing only the auxiliary circuits. The diagram shows that on pressing one or other of the "Start"

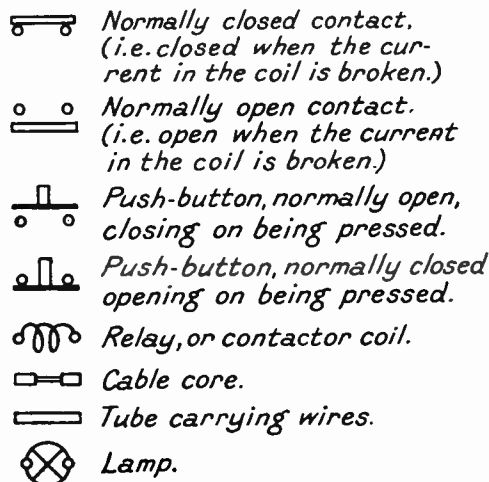

Fig. 1.—HERE ARE GIVEN THE CONVENTIONAL SIGNS USED IN DEVELOPED WIRING DIAGRAMS.

buttons the circuit through the bobber of L is completed, L closes and its auxiliary contact closes, thus short-circuiting the start-buttons. The contactor L can be opened by pressing one or other of the two "stop" buttons, or opens when one of the overload trips functions.

The above example is simple and a developed diagram would not really be necessary to study it. The utility of the developed diagram becomes greater, however, the more complicated is the wiring.

Another Example.

Fig. 4 represents the circuit diagram of a simple four-floor A.C. lift contactor gear, and Fig. 5 the same diagram in developed form.

The lift is driven by a three - phase motor which is started and reversed by two contactors I and II. The lift is controlled by a series of push-buttons in the car (CB) or by floor-buttons (FB) situated by the floor gates. The lift can only be set in motion when all the gates are closed (gate switches GS). It is stopped automatically by the floor switches (FS I and FS II) or the limit switches (LS I and LS II). When anyone is standing in the lift the car floor switch FS puts the floor buttons out of action, so that the car can only be started and stopped from inside.

It will be seen that by pressing the button corresponding to the floor at which it is desired to stop, the corresponding floor relay (III, IV, V or VI) is closed. At the same time one or other of the motor contactors closes, depending on whether the car is above or below the floor at which it is desired to stop.

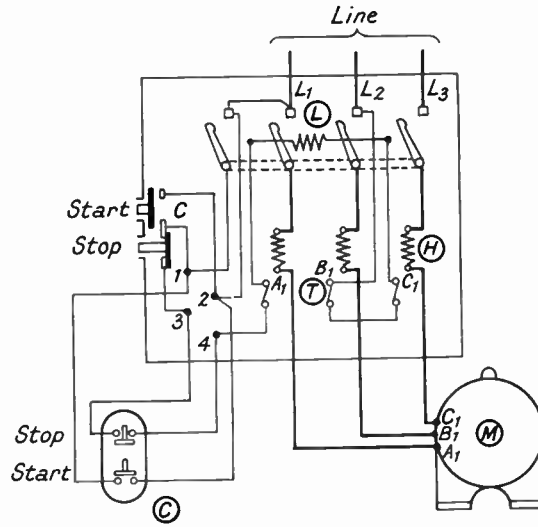

Fig. 2.—ORDINARY WIRING DIAGRAM OF A.C. MOTOR STARTER CONNECTIONS, WITH PUSH BUTTON CONTROL FROM TWO POINTS.

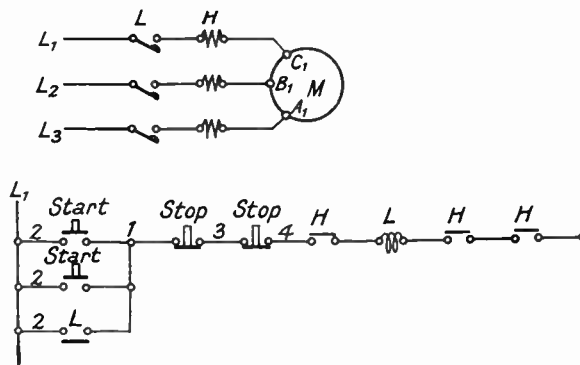

Fig. 3.—DEVELOPED DIAGRAM CORRESPONDING TO THE WIRING DIAGRAM IN FIG. 2.

The car starts and continues to move until the floor switch at the level at which it is desired to stop opens the floor relay.

Rules for Constructing the Diagrams.

The following rules have been found useful:

(1) Each circuit should start on the left and finish on the right without ever reversing its direction.

(2) All circuits should be represented as they would be were there no voltage in any part of the system.

(3) The sequence of operations should be from the top downwards.

(4) As far as possible all representing pieces of apparatus which have the same or similar functions (i.e., relay coils, push-buttons, etc.) should be arranged on the same vertical line.

(5) Start by drawing the main circuit diagram; give each piece of apparatus, switch, contactor, relay, etc., a number or letter; each contact on a certain piece of apparatus bears the same number or letter.

The Uses of Developed Diagrams.

The use of developed diagrams will be

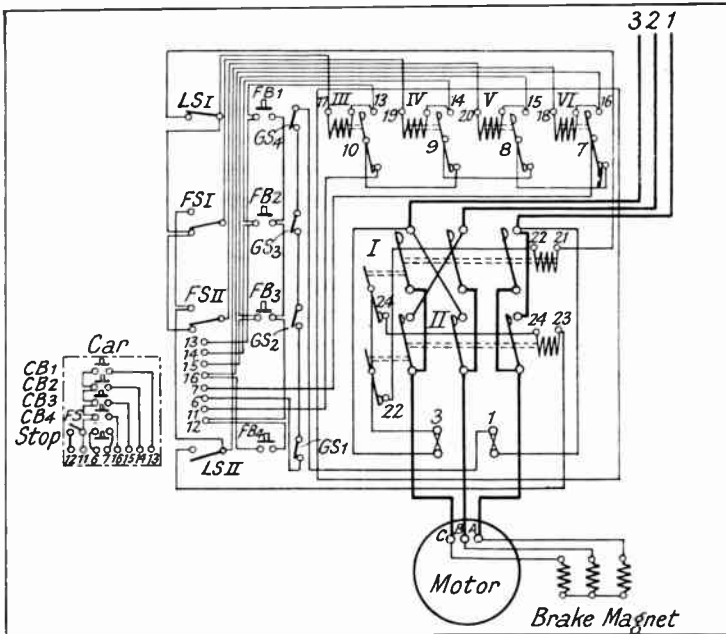
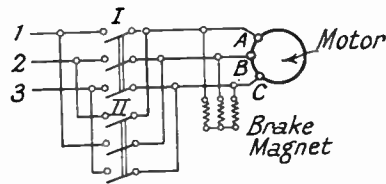

Fig. 4.—Circuit Diagram of a Four-Floor A.C. Lift Controller.

found to save a great deal of time in establishing diagrams of connections. With a small amount of practice one can make them as quickly as one can write, and with the same facility. Contacts can be added or removed, moved from one contactor to another and so on with the greatest ease. The developed diagram can then



be used to make the wiring diagram for the shop. By proceeding in this manner one has the least chance of making mistakes; it is easy to eliminate redundant circuits and superfluous contacts and detect "feed backs" and similar troubles.

On the other hand, no method of studying an existing diagram is so easy as to develop it.

One can complete such developed diagrams by marking on the lines representing the circuits their entry into and leaving of tubes and cables (see signs Fig. 1).

Complicated Interlocking Schemes.

If very complicated interlocking schemes are to be studied, it is helpful to place over each contact on the diagram a small pearl button between two holes in which a thread has been tied. By turning the button 90 degrees, one can represent the opening or closing of the contact; different coloured buttons can represent different sorts of contacts i.e., black buttons

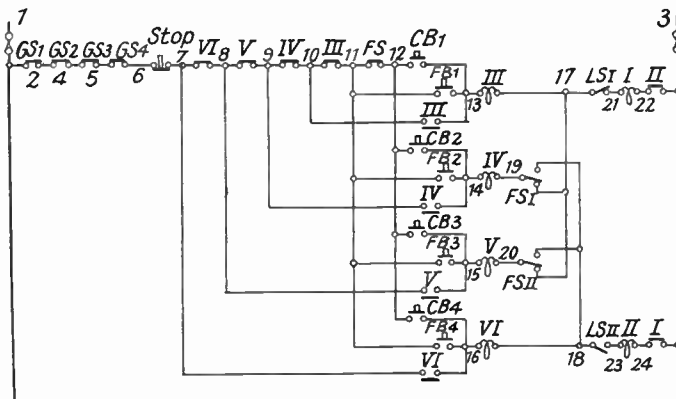

Fig. 5.—THE SAME DIAGRAM AS FIG. 4, BUT DEVELOPED.

The upper part represents the main circuits of the motor and the brake magnet which lifts the brake each time the motor is started up. The lower part shows the auxiliary circuits for the control.

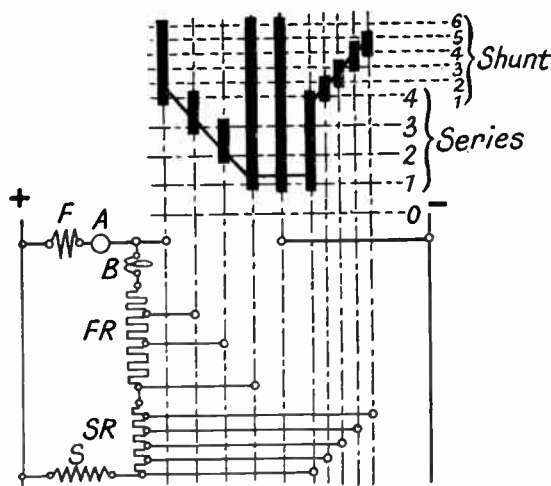

Fig. 6.—DEVELOPED DIAGRAM OF A DRUM CONTROLLER FOR SPEED CONTROL OF A COMPOUND MOTOR.

There are three series speeds and six shunt speeds, obtained first by connecting the series resistance *FR* in series with the motor, and then by reducing the strength of the field by means of the shunt resistance *SR*.

represent contacts which are open when the current in the coil is broken, and white

ones contacts which are closed when the current is broken and so on. By this means even the most complicated circuit diagrams may be followed quite easily.

How to Deal with Controller Drum Circuits.

In circuit diagrams where there are controller drums it will frequently be found necessary to split up the drum into several parts in order to avoid crossing or turning back of circuits.

Fig. 6 shows a simple controller circuit, where this splitting up has not been necessary. The controller drum is represented above with the fixed drum fingers below. These fingers are really of course, arranged in a single row one beside the other. In the developed diagram each is placed on the vertical line cor-

responding to the drum segment which it touches as the controller turns.

SCHEMATIC DIAGRAMS IN PRACTICE

A diagrammatic method similar to that described above has been evolved by the General Electric Company. The reader who follows the diagrams already described will have no difficulty in understanding the method illustrated in Figs. 7-10. It is based on the same principle, with a few minor differences in detail.

How to Make the Diagram.

A list of all the apparatus is written down on the left-hand side of the sheet (see Figs. 7-10) and horizontal lines are drawn right across the page between each piece of apparatus.

A series of heavier lines representing control busbars is drawn at the top and bottom of the diagram. Positive (D.C.) or red (A.C.) at the top, and negative or blue at the bottom.

Arrangement of Circuits.

Between these operating busbars, cir-

cuits are drawn vertically (not horizontally as in the first method), and the operating coils, contacts, etc., in these circuits are inserted opposite the name of the apparatus on the left. Thus the circuits are simply laid out and since the operation of any piece of apparatus changes all the contacts between two of the horizontal lines, the effect of this operation on each circuit may be traced separately.

Some Examples.

Some concrete examples are given in Figs. 7-10, showing the starting and synchronising operations of converters and generators. For the sake of simplicity all protective features are omitted from the diagrams. The key to the symbols used is given below each diagram. The symbols do not differ greatly from those already given. The vertical operating circuits have been lettered for ease of reference.

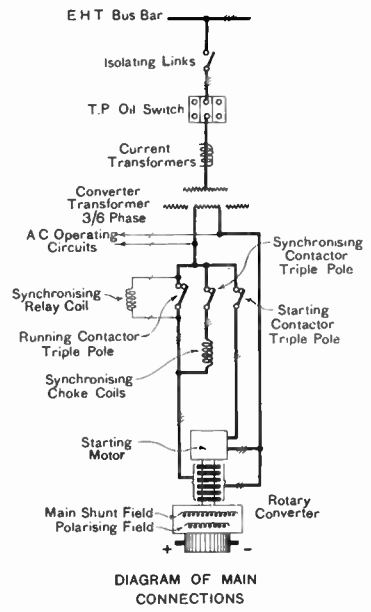
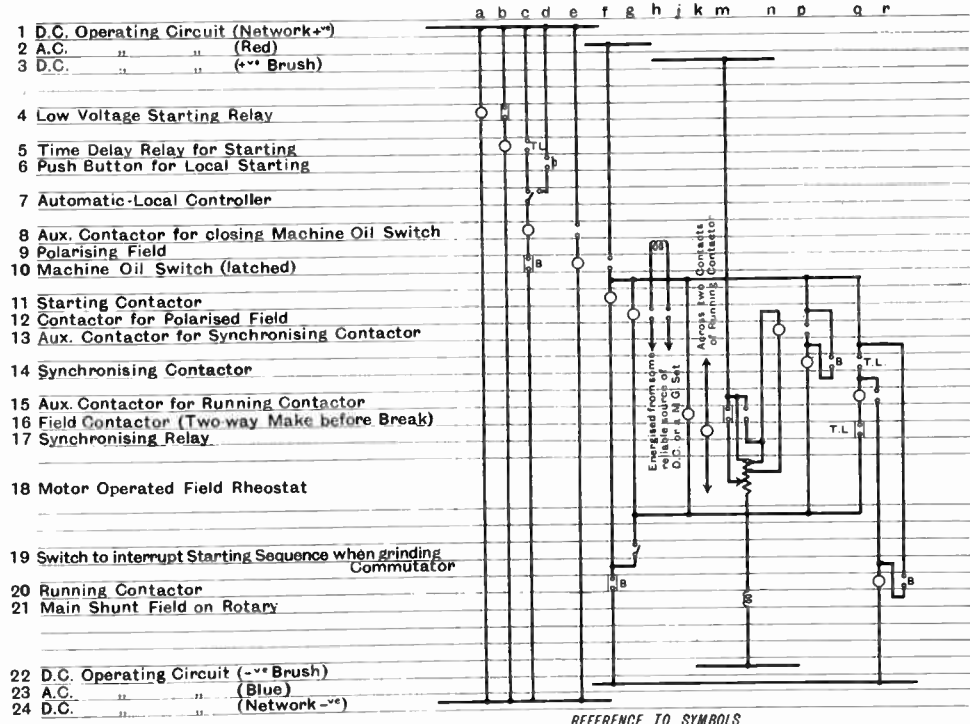

- REFERENCE TO SYMBOLS
- | | | |
|---|--|---|
| (a) Operating Coil | (d) Contacts close early in closing stroke of Main Contacts | (g) Push Button Switch - Push to close circuit |
| (b) Contacts close when Coil is energised | (e) Contacts close early in opening stroke of Main Contacts | (h) As (c) but remain open for Time lag after Coil is de-energised |
| (c) Contacts close when Coil is de-energised | (f) As (b) but remain open for Time lag after Coil is energised | (k) Two-way Controller |

Fig. 7.—DIAGRAMS TO ILLUSTRATE STARTING AND SYNCHRONISING OF MOTOR OPERATED AUTOMATIC ROTARY CONVERTER. It is assumed that a D.C. solenoid-operated oil switch is used. The sequence of operations is as follows: (1) Starting impulse received, (a) by distant control, (b) by low D.C. voltage on bus bars (time delay fitted), (c) time switch. (2) The oil switch closes. (3) Main transformer and A.C. operating circuit energised. (4) Starting contactor closes. (5) The machine runs up as a D.C. generator. (6) Synchronising contactor closes. (7) The machine is pulled into step and held there. (8) Running contactor closes. (9) Machine parallels.

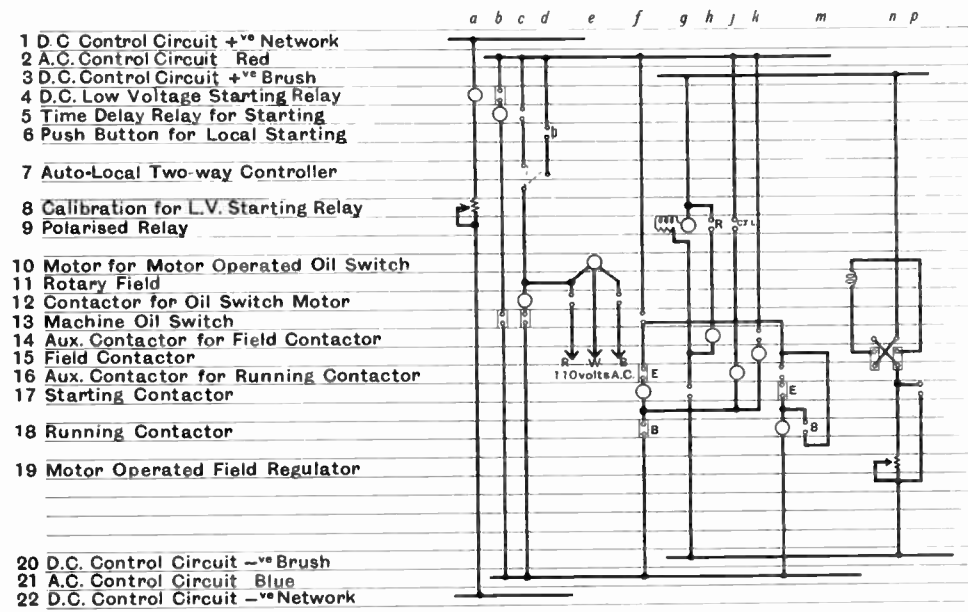

- 1 D.C. Control Circuit +ve Network
- 2 A.C. Control Circuit Red
- 3 D.C. Control Circuit +ve Brush
- 4 D.C. Low Voltage Starting Relay
- 5 Time Delay Relay for Starting
- 6 Push Button for Local Starting

- 7 Auto-Local Two-way Controller
- 8 Calibration for L.V. Starting Relay
- 9 Polarised Relay

- 10 Motor for Motor Operated Oil Switch
- 11 Rotary Field
- 12 Contactor for Oil Switch Motor
- 13 Machine Oil Switch
- 14 Aux. Contactor for Field Contactor
- 15 Field Contactor
- 16 Aux. Contactor for Running Contactor
- 17 Starting Contactor

- 18 Running Contactor

- 19 Motor Operated Field Regulator

- 20 D.C. Control Circuit -ve Brush
- 21 A.C. Control Circuit Blue
- 22 D.C. Control Circuit -ve Network

REFERENCE TO SYMBOLS

- | | |
|--|---|
| (a) Operating Coil | (e) B As (c) but opens late in Closing Stroke of Main Contacts |
| (b) Contacts close when Coil is energised | (f) E As (c) but opens early in Closing Stroke of Main Contacts |
| (c) Contacts open when Coil is energised | (g) R Contacts make when Machine comes up with Reversed Polarity |
| (d) B As (b) but made at beginning of Closing Stroke of Main Contacts | (h) CT Contacts make after a short time lag when Polarity is correct |

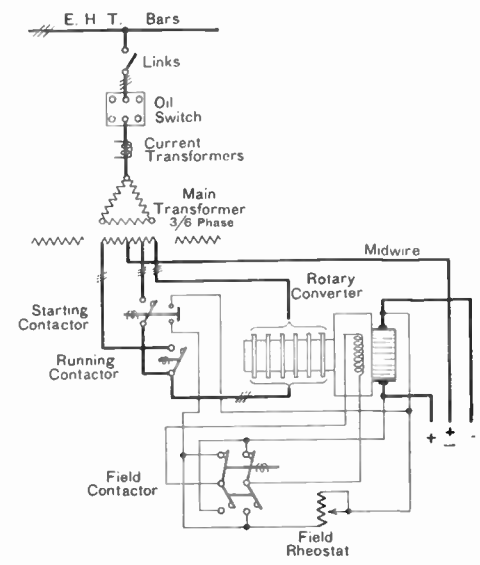
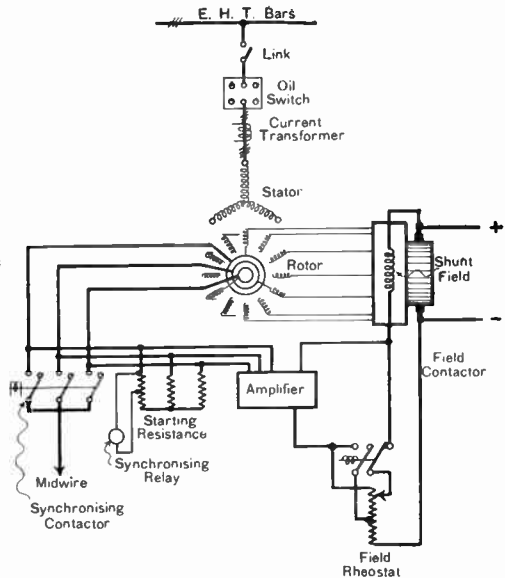
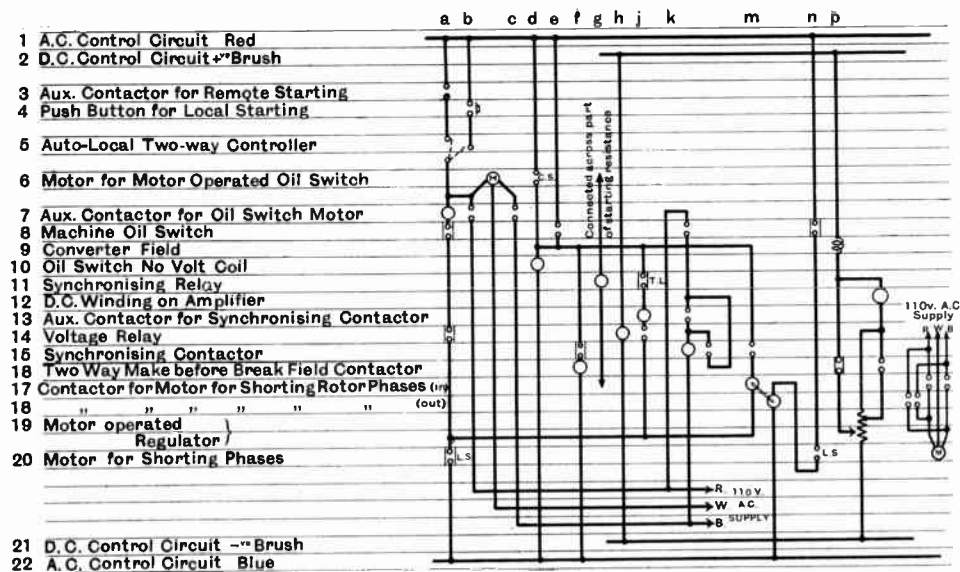

Fig. 8.—DIAGRAMS TO ILLUSTRATE STARTING AND SYNCHRONISING OF AUTOMATIC TAP STARTED ROTARY CONVERTER. It is assumed that an A.C. motor-operated oil circuit breaker is used. The sequence of operations is as follows: (1) Starting impulse received. (2) Oil switch closes. (3) Main transformer becomes energised. (4) Starting contactor closes. (5) Machine runs up. (6) Polarity corrected (if necessary). (7) Machine synchronises. (8) The machine parallels.



REFERENCE TO SYMBOLS

- (a) Operating Coil
- (b) Contacts close when Coil is energised
- (c) Contacts open when Coil is energised
- (d) T.L. As (c) but remain open for a time lag after Coil is de-energised
- (e) L.S. Limit Switch opens when Rotor Phases are shorted by Motor
- (f) L.S. Limit Switch opens when Rotor Phases are opened by Motor
- (g) c.s. Centrifugal Switch closes when Oil Switch Motor runs up to speed

Fig. 9.—DIAGRAM OF STARTING AND SYNCHRONISING G.E.C. AUTOMATIC MOTOR CONVERTER.

It is assumed that an A.C. motor-operated oil switch is used. The sequence of operations is as follows: (1) Starting impulse received. (2) Oil switch closes. (3) Machine stator becomes energised and machine runs up. (4) Machine pulled into synchronism. (5) Synchronising relay (time delay) operates. (6) Synchronising contactor closes (short circuiting starting equipment). (7) All phases of rotor short circuited. (8) The machine parallels.

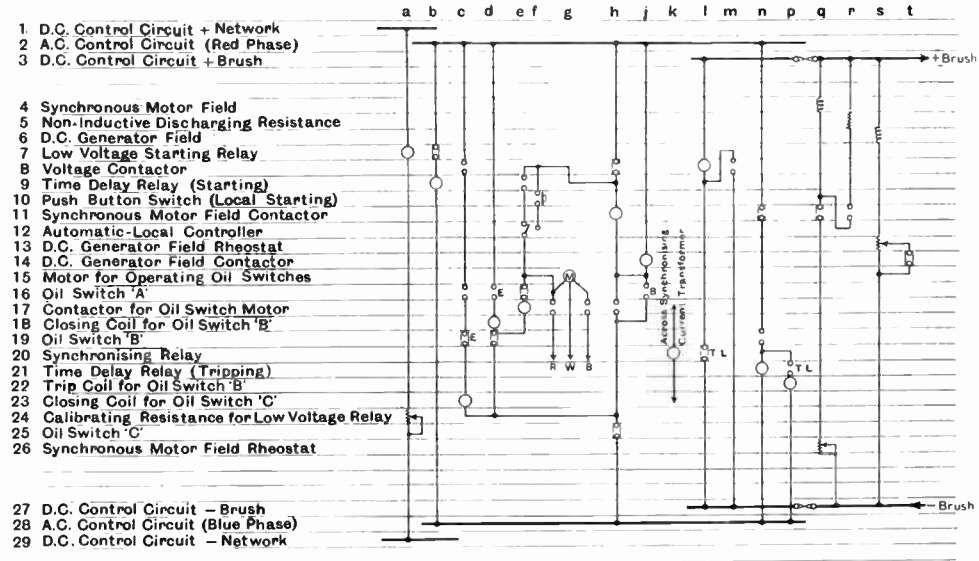

- 1 D.C. Control Circuit + Network
- 2 A.C. Control Circuit (Red Phase)
- 3 D.C. Control Circuit + Brush
- 4 Synchronous Motor Field
- 5 Non-inductive Discharging Resistance
- 6 D.C. Generator Field
- 7 Low Voltage Starting Relay
- 8 Voltage Contactor
- 9 Time Delay Relay (Starting)
- 10 Push Button Switch (Local Starting)
- 11 Synchronous Motor Field Contactor
- 12 Automatic-Local Controller
- 13 D.C. Generator Field Rheostat
- 14 D.C. Generator Field Contactor
- 15 Motor for Operating Oil Switches
- 16 Oil Switch 'A'
- 17 Contactor for Oil Switch Motor
- 18 Closing Coil for Oil Switch 'B'
- 19 Oil Switch 'B'
- 20 Synchronising Relay
- 21 Time Delay Relay (Tripping)
- 22 Trip Coil for Oil Switch 'B'
- 23 Closing Coil for Oil Switch 'C'
- 24 Calibrating Resistance for Low Voltage Relay
- 25 Oil Switch 'C'
- 26 Synchronous Motor Field Rheostat

- 27 D.C. Control Circuit - Brush
- 28 A.C. Control Circuit (Blue Phase)
- 29 D.C. Control Circuit - Network

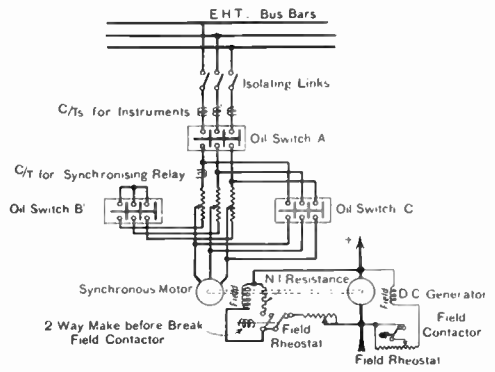

MAIN CONNECTION DIAGRAM

Operation of Oil Switches:
 Springs for closing Oil Switches are compressed
 Oil Switch A closes immediately
 Oil Switches B & C are Cocked until
 released by the Closing Coils

KEY TO SYMBOLS

- (a) Operating Coil for Relay, Contactor or Circuit Breaker
- (b) Auxiliary Contacts Open & Close with Main Contacts, or Close when Coil is Energised
- (c) Auxiliary Contacts Open when Main Contacts Close & Close " " " " Open or Close when Coil is De-energised.
- (d) As (b), but make Contact at the End of the Closing Stroke of the Main Contacts

- (e) As (b), but make Contact early in the Closing Stroke of the Main Contacts
- (f) As (c), " " " " at end of Opening " " " "
- (g) As (b), but with Time Lag on Closing Stroke
- (h) As (c) " " " " " " " " of Auxiliary Contacts.

Fig. 10.—DIAGRAMS TO ILLUSTRATE STARTING AND SYNCHRONISING OF AUTOMATIC SYNCHRONISING MOTOR GENERATOR.

The sequence is as follows: (1) Starting impulse received by either (a) Supervisory gear, (b) low voltage (D.C.) relay, (c) time switch. (2) Oil switch motor contactor becomes energised. (3) Synchronous motor field circuit broken and generator field rheostat arm open circuited to include maximum resistance in generator field circuit. (4) Motor closes oil switch A and cocks oil switches B and C. (5) A.C. stator connected to line. (6) Oil switch B closes. (7) The machine runs up. (8) Operation of synchronising relay. (9) Motor pulls into step. (10) Motor synchronised.

PRACTICAL NOTES ON REGULATIONS FOR THE ELECTRICAL EQUIPMENT OF BUILDINGS (I.E.E. WIRING RULES)

By D. WINTON THORPE, A.M.I.E.E.

SECONDARY BATTERY INSTALLATIONS, SWITCHES AND FUSES

UNDER the general title of "Secondary Batteries," there are certain Regulations which are, I think, worth noting.

Potential Difference Between Cells.

Regulation 60A states:—

Every battery shall be so arranged that a potential difference exceeding 50 volts does not exist between adjacent cells without adequate protection, and that each cell shall be readily accessible from the top and from at least one side.

It may seem idle to comment on this very clear and very obvious Regulation, but I have actually seen a battery—installed it is true, by an amateur—in which, for the convenience of his switchboard and to shorten the lead to and from the battery, a series arrangement of cells started at the middle of the top tier, went along that tier to the end down to the bottom tier, back along the full length of the tier, up to the top tier and back again to the middle, so that in the middle of the top tier were two batteries at opposite ends of the series chain; thus he had a potential difference of 54 volts on the terminals of the adjacent cells at the middle of the top tier. This was clearly a very dangerous state of affairs, since one cannot risk a serious short-circuit in the highly inflammable gaseous atmosphere of a battery room. Had it not been for this danger, the arrangement of cells was quite ingenious.

The normal and probably the best way of arranging cells in a battery is to start on one end of the top tier, work along that tier and downwards at the further end to the next tier, back along that tier and,

if the arrangement of tiers permits it, finish at the end of the second tier; or, alternatively, drop down to a tier below and double back again to the other end. This may, of course, necessitate a rather long run of service cable from the further end of the battery to the switchboard, but it conforms with the requirements of the Regulation and therefore of course, represents prudent practice.

Provision of Spray Arrestors.

Regulation 60D states:—

Cells having containers not sealed or provided with screw-down covers shall be filled with spray arrestors.

Some people, I believe, consider that what are termed "spray arrestors"—that is the sheets of glass which lie diagonally across the top of open-type cells—are merely refinements intended to prevent dust from getting into the cells. This is not so, of course. This particular Regulation is very important because although when battery plants are first erected, it is usual for spray arrestors to be placed on the top of open cells, these sheets of glass are apt to get broken, and in many cases are not replaced. Nevertheless, they do prevent the spray, which is given off by the gassing cells, from rising into the atmosphere and creating an explosive mixture. Instead, the spray collects on the underside of the glass and falls back into the cell.

Ventilation of Battery Room.

Regulation 61 states:—

The room in which the batteries are placed shall be thoroughly well ventilated.

NN

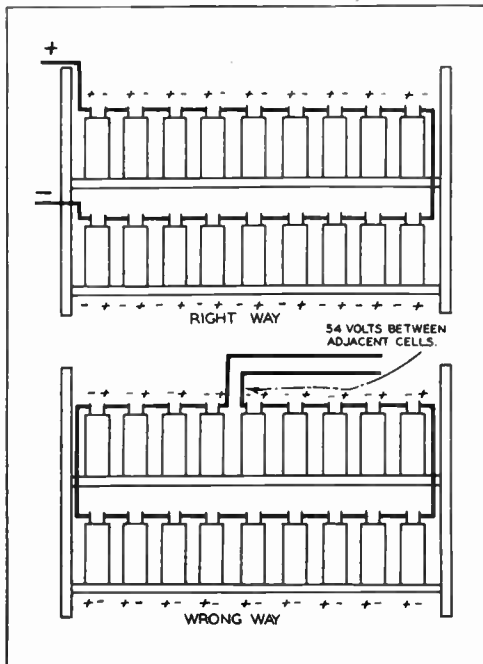

ARRANGEMENT OF CELLS IN A BATTERY. The top picture shows the correct series arrangement. The lower arrangement contravenes the regulations and increases the risk of short circuit in the highly inflammable atmosphere of the battery room. (Regulation 60A.)

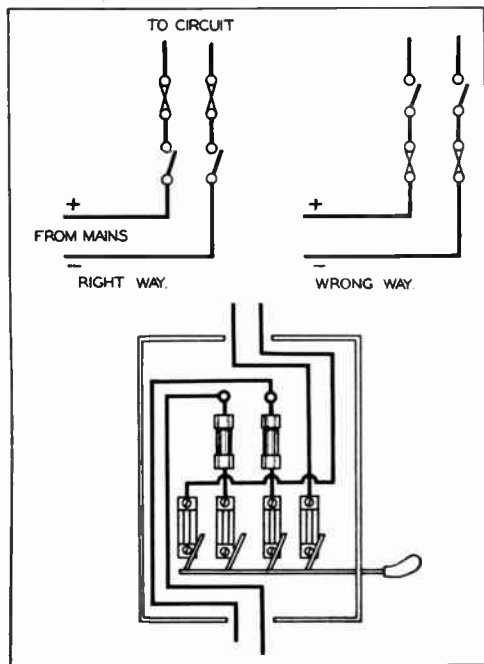

ARRANGEMENT OF SWITCHES AND FUSES. The fuses should be placed so that they are not "alive" when their respective switches are in the "off" position. The lower picture shows an example of switch fuse apparently rightly connected but actually connected wrongly. (Regulation 64M.)

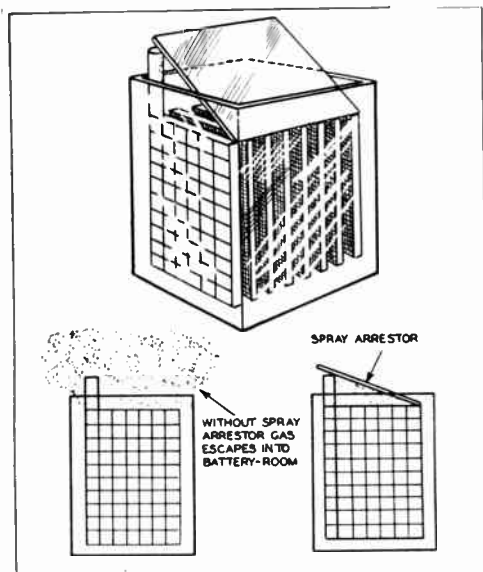

OPEN-TYPE CELLS SHOULD ALWAYS BE PROVIDED WITH SPRAY ARRESTORS. (REGULATION 60D.)

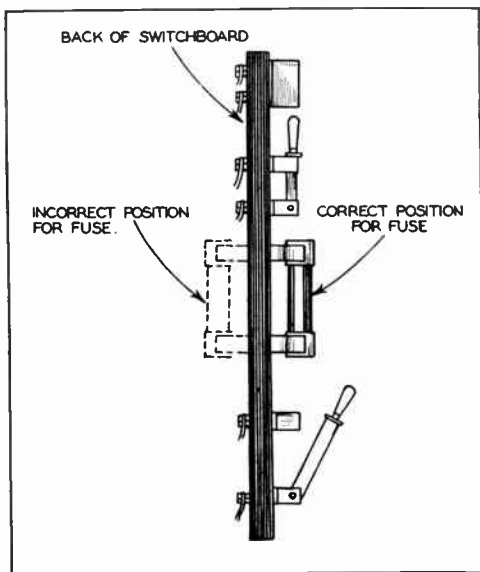

NO FUSE SHOULD BE FIXED ON THE BACK OF THE SWITCHBOARD. (REGULATION 64F.)

Ventilation is one of the most important, if not the most important, considerations when designing a battery room, or deciding upon an existing room to serve as such. The ideal ventilation demands a natural circulation of air, that is to say, an intake point near the ground and an exhaust point near the roof or ceiling. It is a matter upon which the architect or builder is likely to be more expert than an electrical engineer and, in most cases, it is well worth employing the services of someone who thoroughly understands the question of ventilation. In the case of ventilating an existing room, a fairly satisfactory impression of the ventilating qualities may be obtained before the batteries are placed in position by burning newspaper, etc., and watching the behaviour of the smoke. If the smoke hangs about it may reasonably be assumed that the room is not well ventilated; if, on the other hand, it can be seen that there is a clear through current of air which keeps sweeping through and washing out the atmosphere, then the room may be considered to be satisfactorily ventilated.

The purpose of this Regulation is as before—to obviate as far as possible the existence and stagnation of explosive gas in the battery room. It is a most important Regulation and one which I am afraid is very often ignored.

Protection of Switchboards from Acid Fumes.

Regulation 63 states:—

Open-type switchboards . . . shall be so arranged as to prevent access of acid fumes from batteries to the boards . . .

The acid fumes which are given off by every battery have a deleterious corrosive action upon metal and, since all switchboards contain a great deal of metal, this Regulation has been very properly drafted. A switchboard inside a battery room is definitely at variance with the spirit and even the letter of this Regulation, if it is an open-type switchboard. Even with enclosed type switchgear, the acid fumes from the battery room are definitely injurious. There is no doubt that to place a switchboard of any sort inside a battery room, though it may be extremely con-

venient from the point of view of layout, is inexcusably bad practice.

Accessibility of Switchboard Parts.

Regulation 64F says:—

All parts (of a switchboard), including connections, shall be readily accessible; and no fuse shall be fixed on the back of the board.

Generally speaking, the electrical contractor will buy switchboards from the manufacturer. There are, however, occasions when a board has to be specially made up, and not infrequently this Regulation is defied because the back of a switchboard seems a neater place for a fuse than the front. If placed on the front of a switchboard, the fuse is readily accessible, whereas it is inaccessible at the back and much more likely to result in the operator accidentally making contact with some live conductor and getting a shock. On the front, it acts as a reminder to the operator to switch off before changing the fuse. In addition, the combustion when the fuse blows is unlikely to do any damage if the fuse is mounted on the front, whereas, if mounted on the back, it may tend to burn some of the many conductors leading to the back of the board.

Switch Fuses.

Regulation 64M states:—

In every case in which switches and fuses are fitted on the same pole, these switches shall be so arranged that the fuses are not alive when their respective switches are in the "off" position.

This Regulation is primarily intended to avoid the bad practice of drawing and replacing fuses from and on a live conductor. If we have a switch fuse, and for the purposes of reloading a fuse we turn the switch off, it is reasonable to expect that the fuse upon which we are operating is dead. But if this Regulation has been contravened, and if the wiring has been carried out in such a way as to bring the switch on to the dead side of the fuse (or the fuse on the live side of the switch), then turning off the switch will not have the effect of deadening the fuse upon which we intend to work. This point cannot always be seen from a visual examination of the relative positions of the two, since circumstances may and often do

demand that the switch be *apparently* placed on the live side of the fuse, whereas, in effect, it is wired in such a way as to bring the fuses on the live side of the switch. Great care should be paid to this Regulation as contravention of it is undoubtedly the cause of quite a large number of accidents, particularly in connection with switch fuses in factory operation.

Colouring of Busbars.

Regulation 64X states:—

Where a scheme of colouring is employed to distinguish switchboard omnibus bars and connections to individual poles or phases, such scheme of colouring shall conform in all respects to British Standard Specification No. 158.

The colouring of busbars is really a very important matter nowadays since it is by such colouring that the phases can easily be distinguished from one another and from the neutral. To open a busbar chamber and confuse a phase with neutral may mean the difference between potential difference of 250 volts and one of 415 volts. Anyone who has experienced a 415-volt alternating current shock will sympathise with the person who drafted these Regulations. Apart from this, however, it is of the utmost importance that a phase shall be easily recognisable in order to achieve a proper balance of load between phases.

In these days of extensive 3-phase wiring it is becoming more and more usual to have to colour one's busbars in some manner, and endless confusion is caused if the installing engineer does not realise, as he is asked to in this Regulation, that the British Standard Specification on the subject lays it down quite definitely that the colours for such phase-colouring are red, white and blue for the phases, with black for the neutral.

State of Insulation.

Regulation 66 states:—

Where private generating plant is installed, main switchboards shall be provided with suitable means for indicating the state of the insulation of the system, either by lamps or voltmeters or otherwise, except in the case of extra low pressure plant having a capacity not exceeding 5 kilowatts. This Regulation shall not apply to systems

installed in accordance with Regulation 88. (That is, systems making use of earthed concentric wiring.)

It is, unfortunately, rather easy to forget that insulation and voltage go hand in hand. The higher the voltage the more important becomes the question of insulation. Moreover, it is quite useless to rely on an initial insulation test as a criterion of the state of that insulation at a subsequent date. For this purpose the Regulation quoted has been drafted to emphasise the necessity of having a perpetual indicator of some sort to show what is the state of the insulation on the system.

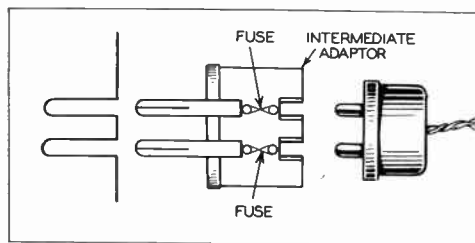

THIS SHOWS THE CONDITIONS UNDER WHICH A FUSE MAY BE PLACED IN AN INTERMEDIATE ADAPTOR.

The fuse should be rated at not more than 5 amps. The consuming device should take 5 amps. or less.

It is perhaps worth noting that since the drafting of this particular Regulation, which called for an indicator in the form of a lamp or voltmeter, a piece of apparatus has been developed and is being manufactured on the Continent known as an earth leakage circuit-breaker which, though not specifically mentioned in this Regulation, probably comes within the spirit of it. This piece of apparatus is nothing more or less than an ordinary circuit-breaker designed to operate at very low current. It is connected between the metal sheathing of the installation and earth, so that if the insulation resistance of the system is reduced sufficiently to allow of a passage of current from the conductor through the insulation to the sheathing, and thence through the apparatus to earth sufficiently strong to warrant notice being taken of it, the circuit-breaker will trip and the circuit will be broken. Anyone interested in this particular aspect

of installation work should read a book entitled "Artificial Earthing for Electrical Installations," by T. C. Gilbert, A.M.I.E.E. Although one has not the time to go deeply into the question here, it is, undoubtedly, a matter which is exercising the minds of most installation engineers very considerably at the present time.

It is as well to bear in mind that the only two exceptions to this Regulation are those which refer to earthed concentric wiring, or alternatively, to extra low-pressure plant of under 5 kW. capacity; that is to say, pressure normally not exceeding 30 volts in the case of A.C. and 100 volts in the case of D.C. Though ordinary small private house plants, operating at 100 volts or less, are excluded from the provisions of this Regulation, there are very many plants installed at 200 volts which clearly come within the province of this Regulation. Moreover, it is worth noting that as the tendency to use heavy current-consuming devices increases, so will the tendency to install higher voltage private plants increase.

Circuit-opening Devices.

Regulation 67C states:—

Every circuit-opening device shall be so constructed and arranged that when placed in the "off" position it cannot accidentally move sufficiently to close the circuit.

The best test of a switch is to take off the cover and move the dolly as slowly and deliberately as possible, in order to endeavour to bring the contacts slowly together. In the best type of quick-make and quick-break switch, it will be found that this is impossible, for, on the first movement of the dolly, no movement is apparent in the actual switch contacts, whereas, as the dolly is pressed further home, the switch contacts fly over quickly and make an abrupt and definite contact. The same procedure may be applied for breaking contact.

The title of "circuit-opening device" is apt to make one think in terms of circuit-breakers, whereas, in fact, it is merely the covering epithet for any sort of device which performs this duty. For instance, a 5-ampere tumbler switch is a circuit-opening device, and if one looks

round many of the houses to-day which have been wired for some time, it is not unusual to find that the movement of such a tumbler switch is so slack that it very often does accidentally move sufficiently to close the circuit. In other words, one need have no hesitation in condemning such a switch in so far as the Regulations are concerned. It might be thought at first sight that provided this accidental movement did only succeed in closing the circuit and did not provide a short-circuit, there is no need for a regulation of this sort. Further thought shows, however, if it can be accidentally moved near enough to close the circuit, then the danger of persistent arcing becomes very serious and the switch in question becomes a menace.

Where Fuses Should be Placed.

Regulation 68A (f) states:—

Fuses shall not be placed in ceiling roses, in switches other than fuse-switches or those of the metal-covered type which comply with the Home Office Regulations, or in wall plugs or sockets. A fuse rated at not more than 5 amperes may, however, be placed in an intermediate adaptor designed for insertion into a wall socket and for receiving the pins of a smaller plug connected to a consuming device taking 5 amperes or less, provided that in all cases the wall socket or sockets shall be protected by sub-circuit fuses mounted in accordance with Regulations 68 (g). Where such an adaptor is used it shall not be sunk below the surface of the wall and its base shall comply with Regulations 68 (c).

A fuse is, after all, the one place in an electrical installation where combustion may, as indeed it probably will, take place. When a fuse blows it does not just quietly melt and cut off current but, having broken the current by melting, it draws out for the moment a fairly substantial arc, which is extremely hot and usually takes the form of a more or less momentary explosion on a small scale. If this fact is appreciated it will be understood why it is undesirable and even dangerous to run counter to the requirements of this particular Regulation. Fuses should be treated with more respect than any other part of an electrical installation. I say this advisedly, and without any qualification whatsoever.

Position of Cut-Outs.

Regulation 68A (g) states:—

When cut-outs are not fixed on a switch-board, they shall be grouped on distribution boards or, unless completely enclosed, shall be contained within cases conforming in all respects to the requirements specified in Regulation 69 below.

Regulation 69 referred to deals with Section and Distribution Boards. This requirement expressly forbids a practice which again is very prevalent, that of placing cut-outs individually at convenient points about a house. This is particularly noticeable in extension work where perhaps the existing distribution fuseboard has not got a spare way to accommodate a new circuit which may be required, and many electricians consider that they are at liberty to put in a cut-out at any position in the house that appears to them convenient. I have known these cut-outs placed in most inflammable positions, tucked away in cupboards behind books and, in short, without any regard to this particular Regulation.

Fuseboards.

Regulation 68B (c) states:—

The busbars, fixed contacts, removable contacts and fuses shall be so shielded as to protect a person against accidental contact with live metal when the fuse carrier is being inserted or removed.

Although it is highly desirable to turn off the main switch before handling a fuseboard in any way, there is no doubt that fuseboards are handled when they are alive. This being so, the desirability of having no chance of accidental contact between the hands and live portions of metal becomes immediately apparent. The old-fashioned type of fuseboard, which is still on the market and is perfectly sound from a technical point of view, has fuse-

bridges in which the contacts attached to the fuse-bridges are part and parcel with a metal band, either of copper or brass, round the porcelain bridge itself, forming part of the mechanical structure of the contact. Although this type of fuse is obsolescent, I know that those manufacturers who still have a certain demand for it, will not object to the suggestion that it is stretching one's conscience rather far to imagine that it comes within the provisions of this particular Regulation.

If we approach a fuseboard in the dark—and it must be remembered that in many cases these are just the circumstances in which a householder does approach a fuseboard—he puts out his hand and quite probably will touch the live metal on the end of the fuse-bridge. If, on the other hand, the bridge is so shielded with porcelain as to make it a practical impossibility for him to touch any live metal, he can, with complete confidence, approach the fuseboard even when it is alive and remove a fuse for reloading. I particularly do not want to be too didactic on this point, because I myself have recently had evidence as to the doubtful interpretation of this Regulation. But what I state must be taken as my view rather than my assertion.

It is as well to qualify these remarks by saying that if any electrical installation engineer asks for a fuseboard from any reputable British manufacturer to-day he will, in default of specified requirements, receive a type of fuseboard that is known as the "Home Office" type which conforms in every respect with the requirements of this particular Regulation. If, on the other hand, he is buying foreign fuseboards, then he must be very careful to see that the Regulation is complied with.

THE DESIGN AND USES OF ELECTRICAL RELAYS

By H. E. J. BUTLER

In this article, Mr. Butler contributes useful data on the construction of electro-magnetic relays, including double coil and polarised relays. The information given on solenoids provides a useful addition to the sparse literature on this subject

Types of Relays.

THERE are three principal types of electrical relays. First there is the electro-magnetic type with a movable armature, which operates electrical contacts or some mechanical device. This type is the most used.

The second type is the electro-magnetic relay with a movable core, which may operate either electrical contacts or a mechanical device. This kind of relay is called a solenoid.

The third type is electro-thermal, where the heating effect of an electric current is utilised to operate electrical contacts. This type is not generally suitable for operating a mechanism on account of its slow action.

Purposes of Relays.

The principal use of a relay is to control a large current by means of a smaller one, or to make the actions of two electrically independent circuits dependent upon one another. Relays of a slow-acting type are used to produce an interval of time between the operation of one circuit and another. Relays are invaluable for the remote control of switches in substations.

How Relays are Used.

There are two fundamental methods of using relays. The first is by

series operation. That is to say, the relay winding is placed in the actuating circuit, so that the relay is operated by a break or make of the main circuit or by a change of current in the actuating circuit. Series relays are of comparatively low resistance, because their inclusion in the circuit must not entail any appreciable loss. The most familiar form of series relay is the overload release in a D.C. motor starter, where an

increase of current through its coils, which is in series with the armature of the motor, causes its contacts to short-circuit the holding magnet of the starter arm. This allows the arm to return to the off position, thereby protecting the motor from the overload.

Another form of series relay is the supervisory relay of the manual telephone exchange. This relay, which is interposed between the battery and a connected subscriber maintains a partial short-circuit on an indicating lamp, while the subscriber is drawing current from the battery. As soon as the subscriber hangs up the receiver the current is cut off. This allows the relay to return to normal, thereby removing the short-circuit from the lamp, which now lights up. This gives the indication to the operator that the subscriber has finished conversation.

Thus the operation of

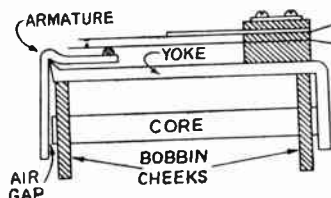

Fig. 1.

A MOVING ARMATURE RELAY WITH THE BOBBIN EMPTY. Showing the principal features of the construction.

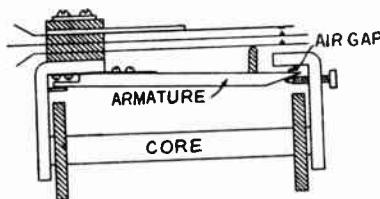

Fig. 2.

A SECOND TYPE OF MOVING ARMATURE RELAY WITH THE CONTACTS ARRANGED TO MAKE THREE POINTS.

a series connected relay depends on the conditions existing in the circuit in which it is placed, while its contacts either control or indicate the condition of that circuit. A relay connected in series with one circuit may also be used for controlling a second circuit.

Shunt Operated Relays.

The second method of connecting a relay is in parallel with the actuating circuit. In contrast with the series operated type the shunt operated relay has to work on the voltage of the circuit across which it is placed and not the current. A shunt operated relay is therefore used to make or break a connection when the voltage of the circuit across which it is connected is altered. A shunt connected relay may also be used to give an indication that the circuit is normal or abnormal. This is done by the contacts of the relay controlling lamp circuits or by means of visual mechanical indicators, which are worked by the armature.

Circuit Breakers.

A relay which cuts off the circuit to which it is connected by means of an overload of current or voltage is called a circuit-breaker. A series operated circuit-breaker is used instead of a fuse when it is

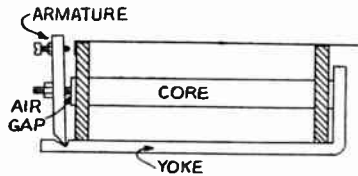

Fig. 3.
A SENSITIVE TYPE OF RELAY SUITABLE FOR A SINGLE MAKE.
The armature and the yoke form part of the electrical circuit.

not possible or desirable to use a fuse for checking an abnormal current. A shunt operated circuit-breaker is used for breaking a circuit when an excess voltage occurs. A fuse is not suitable for this purpose, because it can only be connected in series with a circuit when

it can control only the current and not the voltage.

THE MAGNETIC RELAY.

Movable Armature Types.

There are three principal components of a magnetic relay. They are the winding or coil, the magnetic circuit and the contacts or switches. There may be more than one coil. The magnetic circuit of a movable armature relay comprises the armature, yoke and the core. Fig. 1 shows the construction of a typical moving armature relay. It has a single winding which is wound in the space between the bobbin cheeks. The yoke, core and the armature consist of annealed Swedish iron or of a special magnetic material such as Stalloy. The contacts are mounted on the yoke and are insulated from it by means of ebonite or bakelite. The arrangement of contacts shown in Fig. 1 is the most simple that is used with this type. As many as three sets of three contacts are frequently used when the circuit conditions require it.

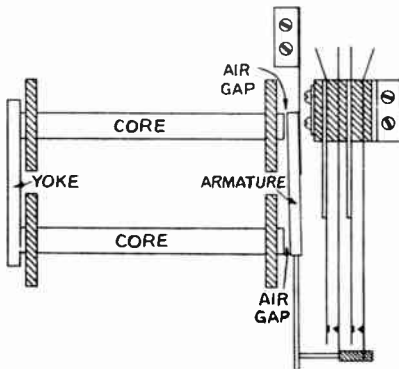

Fig. 4.
A DOUBLE-COIL RELAY WITH AN ARRANGEMENT OF CONTACTS FOR SWITCHING TWO CIRCUITS INDEPENDENTLY.

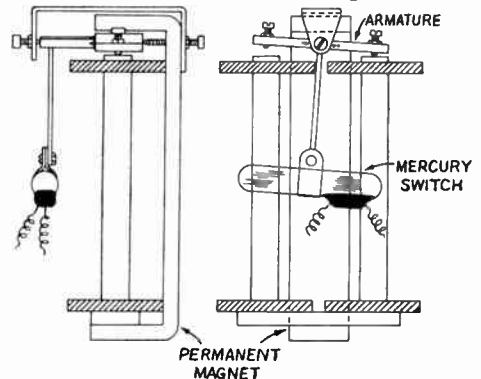

Fig. 5.
THE ESSENTIAL FEATURES OF A POLARISED RELAY.

The bobbins are shown unwound. This type of relay is operated by a reversal current.

A relay of similar possibilities is shown in Fig. 2. In order that the weight of the armature may not affect the power of the relay, it is arranged to work with the breadth of the armature in a vertical plane. That is to say that Fig. 2 represents a top view of the relay.

A third type of moving armature relay is shown in Fig. 3. This is a relay of simple construction, but it is suitable for only a single make. It takes very little power to operate, because there are no spring contacts. The magnetic circuit of the relay forms part of the electrical circuit, so that it is necessary to insulate the relay itself from a metal support.

Double Coil Relay.

A double coil relay, similar in construction to a trembler bell, is shown in Fig. 4. This type is not so sensitive as the foregoing because the magnetic circuit is long and there are two air gaps. It does not lend itself so readily to a self-contained construction like the single coil types. It has the advantage that a large movement of the contacts can be obtained by the extension of the armature, without the necessity of lengthening the air gap.

Polarised Relay.

Sometimes it is necessary to operate a circuit by a reversal of current in the actuating circuit. This is done by means

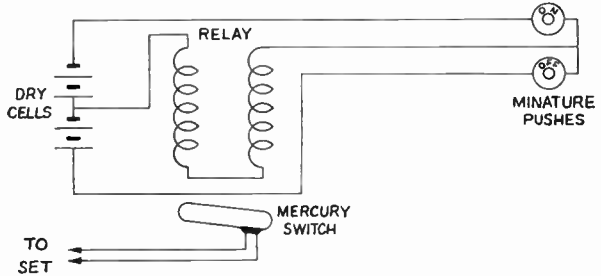

Fig. 6.
THE CIRCUIT OF A REMOTE CONTROL SYSTEM USING A POLARISED RELAY WITH A MERCURY SWITCH.

of a polarised relay. The essential features of this type are shown in Fig. 5. The special feature of this relay is the employment of a permanent magnet. This gives the armature a definite polarity which controls the direction in which it moves when a current passes through the relay coils. The permanent magnet maintains the same polarity at each end of the armature, so that when the relay is energised with the pole faces north and south, one end of the armature is attracted and the other is repelled. When a polarised relay has been actuated, the permanent magnet tends to hold the armature in position. If there are no contacts or other springs to return the armature, no current is required to retain the armature. This condition is obtained by using a mercury switch as shown in Fig. 5.

A circuit for using this type of relay is shown in Fig. 6. It is particularly suitable for the remote control of wireless sets where it is desirable to economise in battery consumption. The relay is controlled by two pushes, which enable the current through the relay to be reversed. This method necessitates the use of at least two cells; single cell operation could be obtained by using a reversing switch instead of the two pushes. This, however, would require an extension of four leads to the switch instead of three as shown in Fig. 6.

Design of Contacts.

An assembly of relay contacts, suitable for the

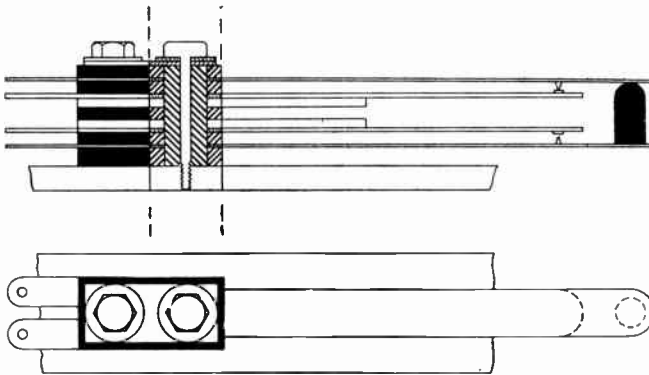

Fig. 7.

AN ARRANGEMENT OF RELAY CONTACTS (ACTUAL SIZE). Showing the principles of construction. The portion of the elevation between the dotted lines is in section.

control of small currents, is shown in Fig. 7. The material used for the contact springs is nickel-silver. The longer springs, which are operated by the relay armature, are thinner than the others. A suitable thickness for the longer springs is .010-.015 in., while the shorter springs are .020-.032 in. thick. In order to obtain a firm contact without making the shorter springs unduly stiff, they are provided with backing strips of thicker material. These are made somewhat less than half the length of the thicker contact springs and about twice as thick.

The contacts themselves are an alloy of silver and gold in the proportion of 90 per cent. silver and 10 per cent. gold, which is sufficiently resistant to corrosion for most purposes. Platinum or platinum-iridium alloy is used in exceptional circumstances.

The contact springs are insulated from one another and from the base as shown in Fig. 7. This part of the assembly is shown in half-section. Each spring has an insulating spacer of ebonite or bakelite, and the whole is clamped together with 6 B.A. screws which are bushed to insulate them from the springs.

The soldering tags of the contact springs are staggered to facilitate soldering, as shown in the plan of Fig. 7.

SOLENOIDS.

Uses.

Solenoid relays are not so efficient as the movable armature types, because the air gap in the magnetic circuit is very large. They are used only when a long movement is necessary to

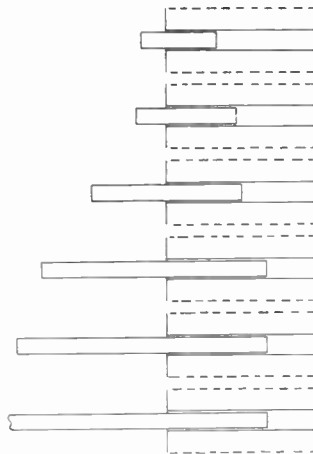

Fig. 8.
THE POSITION OF MAXIMUM PULL OF SOLENOID PLUNGERS OF DIFFERENT LENGTHS.

impart mechanical action or to provide a suitable means of obtaining a long delay action with an oil or air controlled dash-pot. It is possible to obtain some delay in the acting of a moving armature relay, but when more than a few seconds delay is required a dash-pot controlled solenoid must be employed.

Design.

The design of a solenoid is governed by two requirements. The first is the pull required and the second is the length of travel over which the pull must be maintained.

The pull of a solenoid is not easily predetermined, because there are a large number of variable factors. It depends on the following:—

1. The ampere-turns of the coil.
2. The area of the plunger or core.
3. Magnetic properties of the plunger material.
4. Position of the plunger.
5. Length of the coil and plunger.

Position of Plunger.

Fig. 8 shows the position of maximum pull for plungers of various lengths with respect to the coil. As the length of the plunger is increased the position of maximum pull becomes further into the coil, until the length of the plunger inside the coil is two-thirds the length of the coil. Any increase in the length of the plunger beyond $1\frac{1}{2}$ times the length of the coil does not appreciably affect the position of maximum pull.

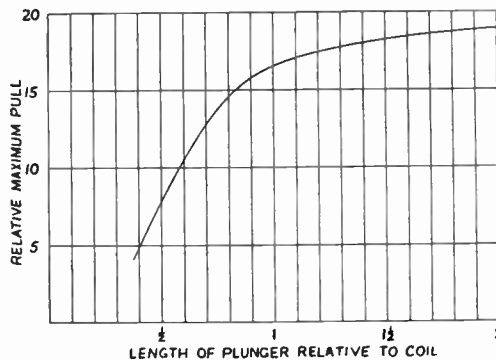

Fig. 9.
A GRAPH SHOWING THE RELATION OF THE MAXIMUM PULL TO THE LENGTH OF THE PLUNGER.

Length of Plunger.

Two things determine the length of the plunger — the travel required and the pull. Up to a point the pull increases with an increase in the length of the plunger. Fig. 9 shows the relation between the length of the plunger with respect to the coil and the pull. It will be noticed that there is not much to be gained by increasing the plunger by more than $1\frac{1}{2}$ times the coil length. Thus, it is evident that the best length for the plunger is $1\frac{1}{2}$ times the coil length.

The actual length of the plunger must be at least three times the stroke if the variation in the pull is to be kept within 15 per cent. of the maximum. Suppose a stroke of three inches is required. The plunger would be nine inches, while the coil would be made six inches long. If the coil and plunger were made longer than this the pull would be obtained with less variation.

If the plunger of a solenoid is allowed to travel to its full extent, equilibrium is

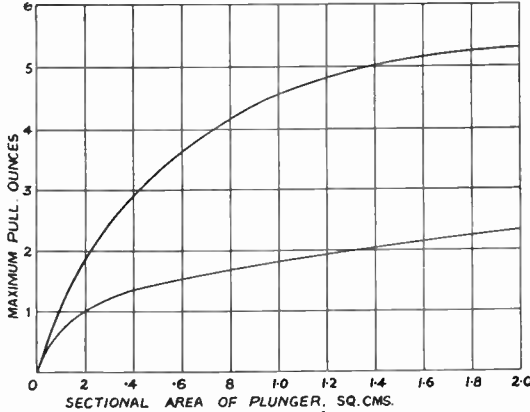

Fig. 10. THE RELATION BETWEEN THE AREA AND THE MAXIMUM PULL OF THE PLUNGER OF A SOLENOID. The upper curve is for a magnetising force of 1,500 ampere turns and the lower curve for 1,000 ampere turns.

the maximum pull is shown in Fig. 10. The following table gives the diameter of plunger to use for maximum pulls up to 1 lb.

Material of Plunger.

reached when the ends of the plunger are equidistant from the ends of the coil, whether the plunger is longer or shorter than the coil.

Sectional Area of Plunger.

For small solenoids allow two square centimetres of section for each four ounces of pull. The relation between the area of the core and

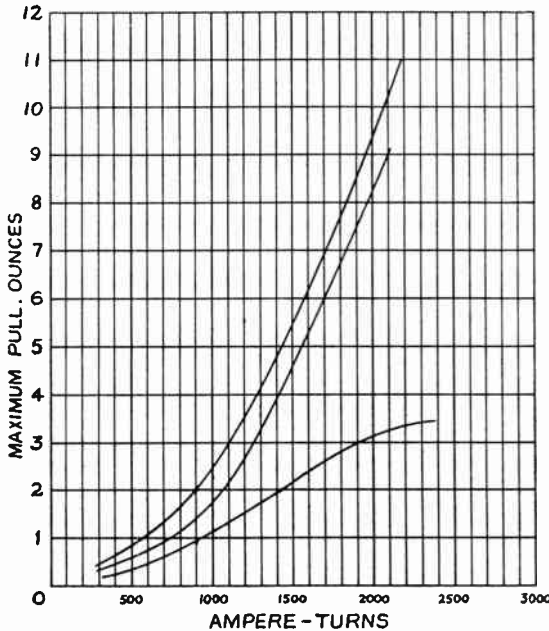

Fig. 11.—THESE CURVES SHOW THE AMPERE-TURNS REQUIRED FOR A SOLENOID 3 IN. LONG WITH A PLUNGER OF THE SAME LENGTH.

The top curve is for a plunger of .307 sq. in. the middle curve for .146 sq. in and the bottom curve for .036 sq. in. sectional area.

The most suitable material for a solenoid plunger is Swedish iron. If the solenoid is to be operated from an A.C. supply the core is composed of a bundle of soft iron wires so as to reduce the losses due to eddy currents in the core. A solid core is quite suitable for D.C. operation. An A.C. operated solenoid is not so efficient as a D.C. one, on account of the losses entailed in the core.

Ampere-Turns Required.

The ampere-

turns required to give a certain pull is more quickly determined by experimental methods than by calculation. The curves in Fig. 11 show the pull obtained from a small solenoid using three different cores. Provided the foregoing principles have been followed the maximum pull required is safely obtained by allowing 250 ampere-turns per ounce pull. Suppose a solenoid is to have a maximum pull of 8 ounces. This would require a magnetising force of 2,000 ampere-turns, which could be obtained by using a 2,000

turn coil with a current of one ampere.

Max. Pull, ounces.	Dia. of Plunger, in.
2	$\frac{7}{16}$
4	$\frac{5}{8}$
6	$\frac{3}{4}$
8	$\frac{7}{8}$
10	$\frac{7}{8}$
12	1
16	$1\frac{1}{4}$

A LIGHTING INSTALLATION MISTAKE

TWO light points are connected to a circuit fed from a distribution board; the wiring is installed in screwed conduit. One of the points takes a 200-watt lamp and the other a 25-watt lamp, and each lamp is controlled independently by its own switch. Due to the mistake in connecting the points to the wiring when both switches are closed, the 200-watt lamp lights up and the 25-watt lamp will not light up; and when the switch controlling the 200-watt lamp is turned off, the 25-watt lamp lights up. This lamp may now be turned off or on by its own switch.

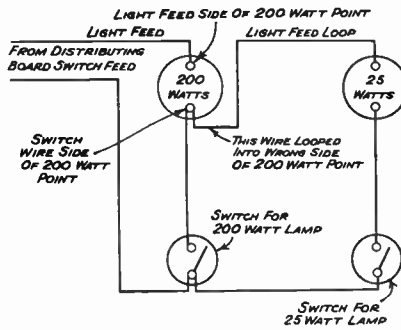

THE INCORRECT CONNECTIONS.

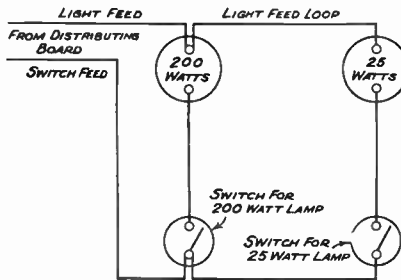

THE CORRECT CONNECTIONS.

The Mistake in the Connections.

The light feed loop from the 200-watt point to the 25-watt point has been looped in to the switch wire side instead of the light feed side, of the 200-watt point.

Rectifying the Mistake.

Change over the light feed loop from the switch wire side to the light feed side of the 200-watt point.

Explanation of the Phenomena Due to the Mistake.

When both switches are closed the voltage across the 25-watt point is approximately zero, therefore this lamp will not light up, but when the switch controlling the 200-watt point is opened, the two lamps are connected in series across the full mains pressure. Owing to the very low resistance of the 200-watt lamp compared with that of the 25-watt lamp, the current passing through the lamps is insufficient to cause the 200-watt lamp to glow, but is large enough to light up the 25-watt lamp to almost full brilliancy. When the switch controlling the 25-watt lamp is opened the circuit is broken.

A RAPID CABLE CALCULATOR

By H. E. HUTTER, A.Am.I.E.E.

How to make and use a calculator, by means of which volt drop, cable section, current or length of line can be determined with one operation.

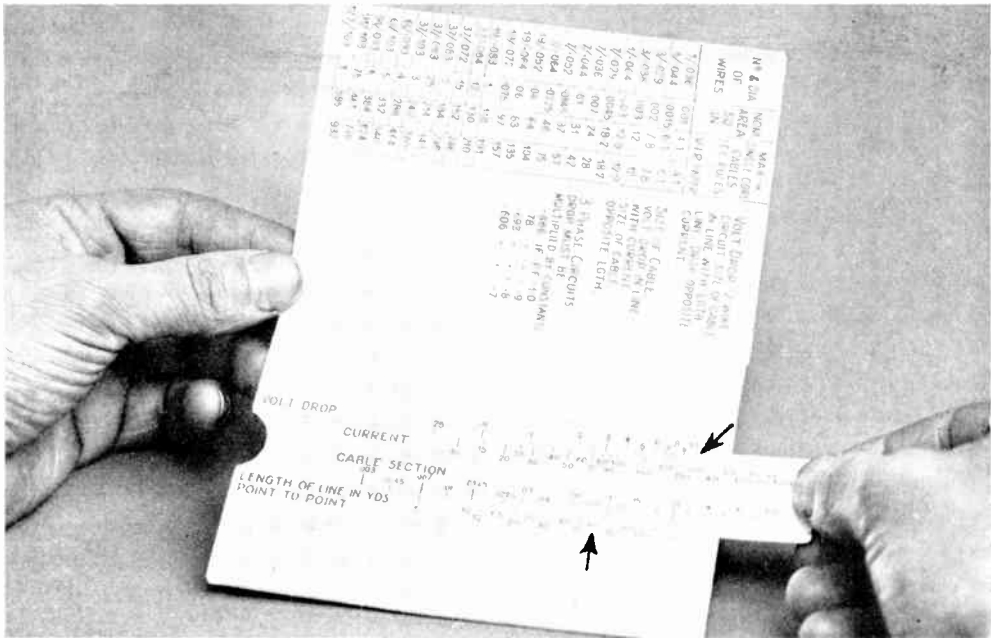

Fig. 1.—THE RAPID CABLE CALCULATOR IN USE.

Showing the working out of the size of cable required in the first example described in the text. The current scale reading of 282 amps. has been placed underneath the volts drop reading of 10. The appropriate size of cable for a length of 60 yards can then be read off on the third scale and will be seen to be just under 0.1 sq. in. It is then, of course, necessary to refer to the table of cable data to see if this size is of sufficient capacity to carry the current demanded of it.

THE calculation of voltage drop in cables is a matter of considerable importance in many classes of work. For example, the Wiring Regulations of the I.E.E. state: "The minimum size of a conductor within a building will be determined as follows: For lighting circuits, by the permissible drop in volts, which must not exceed two per cent., plus a constant allowance of one volt."

The rapid calculator enables any one of four factors to be found instantly when the other three are known. The actual construction is most simple. It consists

of suitably calibrated sliding scales arranged on the slide rule principle.

HOW TO MAKE THE CALCULATOR.

First obtain a piece of bristol board size 15 in. by 6 in. This should be marked out as shown in the sketch (Fig. 2). It is next carefully cut into pieces as indicated. Two side portions are next pasted on the base. The scales, which are given full size in Fig. 3, are then pasted on the requisite piece of board. The slide should then be cut off accurately along the scale lines. The narrow strip is mounted

on the slider strip. The volt drop scale and the length of line scale are then pasted in position on the base, leaving a slot into which the sliding scale can be fitted. The table of wire sizes is next pasted on the uncovered portion, which is then bent over in the centre to form a protection for the calculator.

METHOD OF USING.

To find volt drop, given cable section, current and length of line, slide centre

cable under consideration: Place cable section above length of cable, under volt drop find maximum current permissible without exceeding given volt drop.

To find maximum length of cable of given section which will carry a given current without exceeding a specified volt drop. Place current below volt drop, below cable section read the maximum length.

The volt drop given by the calculator is for two wire circuits, for three-phase

circuits the drop must be multiplied by the following constants:

- 0.866 if power factor is 1.0.
- 0.78 if power factor is .9.
- 0.693 if power factor is .8.
- 0.606 if power factor is .7.

Calculations for cables of sections not given on the slide can be carried out by simple proportion, for example, if the cable section is 0.0225 sq. in. the calculations can be worked out on the basis of 0.05 sq. in. cable, and the result doubled if volt drop is

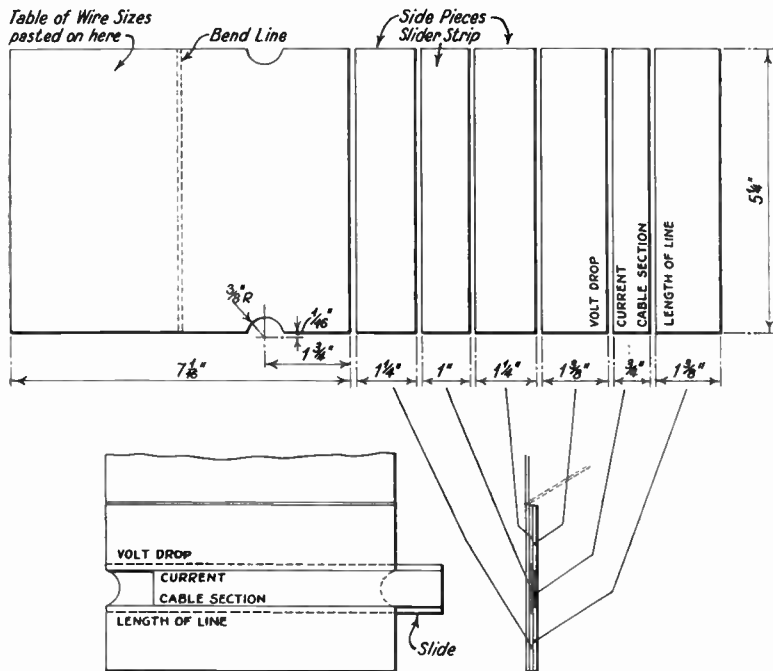

Fig. 2.—How to MAKE THE CALCULATOR.

This shows how the bristol board should be marked out, cut up and pasted together.

scale until cable section is above required length of line. Above the current find volt drop required.

To find cable section, given allowable volt drop, length of line and current: Place current below given volt drop; above length of cable find section. The cable section thus obtained must be compared with the table of allowable current ratings to ensure that the cable is not overloaded. To find maximum current a cable will carry without exceeding a given volt drop for the length of

being worked out.

SOME PRACTICAL EXAMPLES.

Case 1.

Required to find the size of cable necessary to supply a 3-phase motor 440 volts (RMS) 120 h.p.

Efficiency .9.

Power Factor .8.

Length of line from distribution board to motor 60 yards. Permissible volts drop, 10 volts.

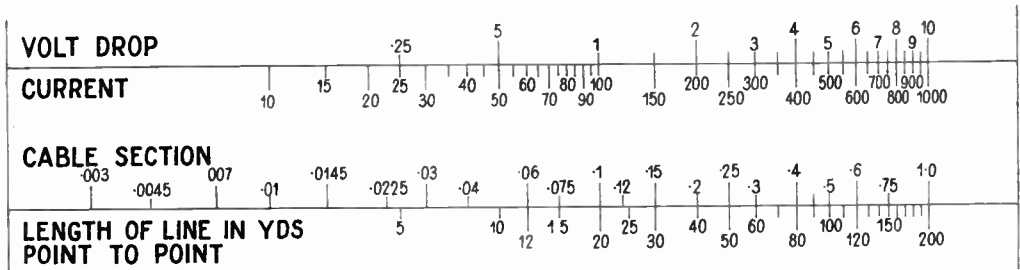

Fig. 3.—THE CABLE CALCULATOR SCALES (FULL SIZE).

To make the calculator, the above scales may be cut out and pasted on to the bristol board. The board should then be cut accurately along the lines of the scale. A razor blade makes a suitable cutter.

In this case a little preliminary calculation is necessary as follows :—

$$\text{Electrical power required in watts} = \frac{\text{Horse-power} \times 746}{\text{Efficiency}} = \frac{120 \times 746}{.9} = 99,466.$$

$$\text{Current} = \frac{\text{watts}}{\text{volts}} \times \text{power factor} = \frac{99466}{440 \times .8} = 282 \text{ amps.}$$

Now placing the current scale reading 282 underneath the volts drop reading of 10, we see on referring to the length of line scale reading 60 that the appropriate size of cable is just under 0.1 square inches, which gives a cable size of 19/.083. A cable of this size will not, however, safely carry more than 118 amps. if rubber insulated, and 191 amps. if paper insulated. The choice of cable must, therefore, in this case be decided by the current carrying

capacity. For a paper-insulated cable the size would be 37/.083 or for V.I.R. cable 61/.093.

Case 2.

A 3-kilowatt fire 220 volts is to be installed in a house.

The length of run between the point and the distribution board is 30 yards.

What size of cable should be used ?

First find the current from the formula—

$$\text{Current} = \frac{\text{watts}}{\text{volts}} = \frac{3,000}{220} =$$

13.5 amps.

Permissible voltage drop = 1 + 2 per cent. of 120.

$$= 5.4 \text{ volts.}$$

Now move the current scale of the calculator until the reading 13.5 is directly below the reading 5.4 on the volts drop scale. The table size is found to be .0045 sq. in. From the table we see that 7/.029 will meet the case.

CABLE DATA.			
No. & dia. of wires.	Nominal area. Sq. ins.	Maximum amps. single core cables I.E.E. rating.	
		V.I.R.	Paper-Insulated
1/.036	.00	4.1	4.1
1/.044	.0015	6.1	6.1
3/.029	.002	7.8	7.8
3/.036	.003	12	12
1/.064	.003	12.9	12.9
7/.029	.0045	18.2	18.2
7/.036	.007	24	28
7/.044	.01	31	42
7/.052	.0145	37	57
7/.064	.0225	46	75
19/.052	.04	64	104
19/.064	.06	83	135
19/.072	.075	97	157
19/.083	.1	118	191
37/.064	.12	130	210
37/.072	.15	152	246
37/.083	.2	184	296
37/.093	.25	214	343
37/.103	.3	240	385
61/.093	.4	288	404
61/.103	.5	332	540
91/.093	.6	384	624
91/.103	.75	461	738
127/.103	1.00	595	932

AN ELECTROLYTIC BATTERY CHARGER

By WELLINGS W. WHIFFIN

THE original electrolytic charger, called the Noden valve, left behind it such a bad reputation that very

many experimenters have associated its shortcomings with the chemical charger in general. The particular rectifier employing lead and tantalum electrodes was enjoying an increasing popularity up to the advent of the metal rectifier, not only for battery charging, but as an eliminator for the H.T. supply in radio receivers.

For reliability and low cost of construction, the electrolytic rectifier is still able to hold its ground for the charging of small car and wireless accumulators.

general experimental research work. Its simplicity and reliability render it especially suitable for the electrical and radio

engineer who finds it necessary to hold accumulators ready for use when required.

Trickle Charging

The charger will be found of great use in maintaining the charge of accumulators permanently installed for a particular purpose. Such applications include fire-alarm, burglar-alarm, call and bell systems,

and the operation of electrical relays where a steady D.C. voltage is required. For these purposes, the charger should be arranged to operate as a trickle charger

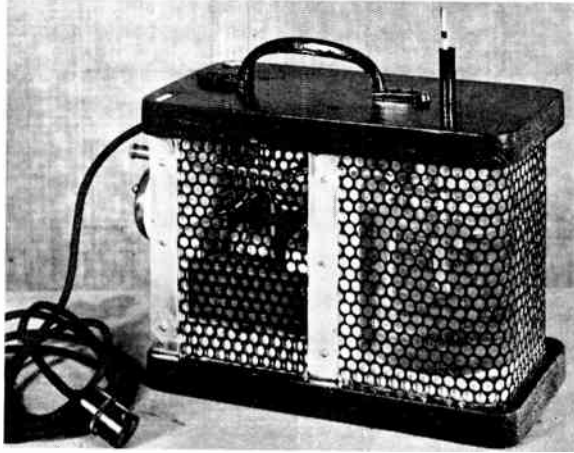

Fig. 1.—THE FINISHED CHARGER READY FOR SERVICE. The normal output is about 4 amps. at 6 volts. This can be modified by using suitable resistances in output leads.

FULL LIST OF MATERIALS REQUIRED.

Two strips Tantalum, 5 in. by $\frac{3}{8}$ in.
Strip thin sheet lead, $9\frac{1}{2}$ in. by 1 in.
Perforated sheet iron, 24 in. by 6 in.
6 dozen pairs Stalloy No. 4 Transformer stampings.
Mains switch, 5 ampere type.
2 large terminals.

Metal carrying handle.
Quantity stiff cardboard.
Transformer wire, $\frac{1}{4}$ to $\frac{1}{2}$ lb., see Table.
Mains twin flex and plug.
Ebonite tube $2\frac{1}{2}$ in. long by $\frac{1}{2}$ in. diameter.
Planed deal wood, 32 in. by 3 in.

Strip of Aluminium 24 in. by $\frac{1}{2}$ in.
2 lb. jam jar in glass.
Small quantity brass screws, Seccotine, shellac varnish, empire tape, systoflex, paraffin wax, sheet rubber and acid-proof paint.

Charging Low Voltage Accumulators.

The charger, illustrated in Fig. 1, is intended primarily for the charging of low-voltage accumulators for motor-car, wireless receiving sets and for the accumulators used in

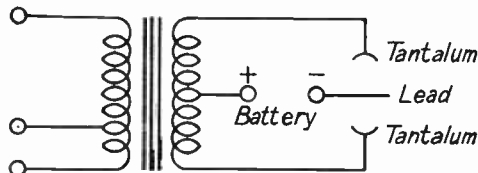

Fig. 1A.—CIRCUIT DIAGRAM OF ELECTROLYTIC BATTERY CHARGER.

permanently wired to the batteries of the system. The rate of charge will probably be decreased under these conditions to suit the demand made. This can be arranged by decreasing the number of turns on the second-

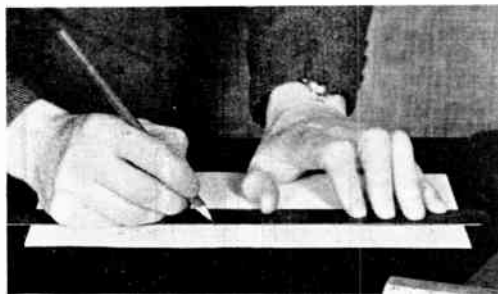

Fig. 2.—CONSTRUCTING THE TRANSFORMER BOBBINS.

Choose a piece of stiff cardboard of good quality and mark it out to the dimensions shown in Fig. 3.

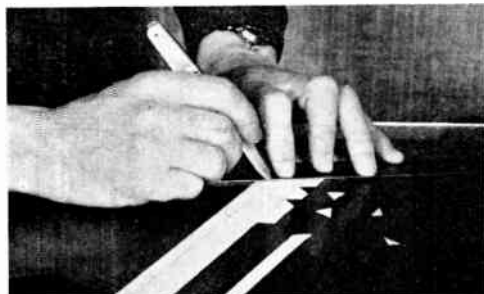

Fig. 4.—CONSTRUCTING THE TRANSFORMER BOBBINS.

After marking out the bobbin on a stiff piece of cardboard, cut the cardboard in the manner shown on a sheet of glass.

dary coil, or more simply, but less economically, by employing a series resistance in the charging circuit. In either case, the object is to obtain a balance between the charging voltage and the back E.M.F. of the accumulators. When the latter falls, the charger automatically restores it until a balance is once again provided.

Constructing the Transformer Bobbins.

Three bobbins are required. The largest and centre one carries the mains primary current, and a smaller one at either side, joined in series, provides the centre-tapped secondary winding of 30 volts.

A stiff cardboard of good quality is chosen and marked out as shown in Fig. 2 to the dimensions given in Fig. 3. The width given is for the smaller bobbins, this value being increased to $\frac{3}{8}$ in. when making the larger one.

Cut the cardboard as in Fig. 4. A wooden former is used on which to bend and glue up the oblong centre portion of the bobbin. When this has thoroughly dried, glue the cheeks in position as shown in Fig. 5 by folding back the projecting tags.

The Winder.

It is a laborious process to wind the centre coil by hand, especially if the mains supply is at 250 volts. A simple winder is illustrated

in Fig. 6, in which is seen one of the completed bobbins. The winder consists of two plywood uprights screwed to a substantial baseboard and supporting a horizontal cranked spindle at their top ends. A block of wood is cut to fit the centre hole of the bobbin and is screwed by a central hole to the winder spindle. Two metal cheeks are clamped at either side of the bobbin during the winding process to prevent the cardboard cheeks from bulging outwards.

Shellacking the Bobbins.

If the bobbins are made before the winder is constructed, the former should now be sufficiently dry for shellacking, an operation which is shown in Fig. 7. The shellac will help materially in stiffening the cheeks and several coats may be given if necessary, particularly on the inside of the oblong hole where the cardboard is likely to be damaged when fitting the laminations of the transformer.

Winding the Coils.

From the table of transformer windings is selected the correct number of primary turns for the appropriate mains voltage. A separate column gives an alternative mains tapping point which enables the charging rate of the instrument to be

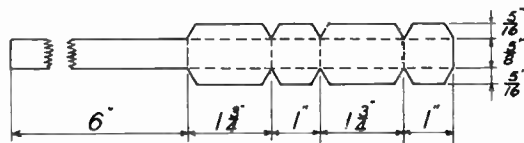

Fig. 3.—DIMENSIONS FOR MAKING OBLONG CENTRE PORTIONS OF CARDBOARD TRANSFORMER BOBBINS. Width of $\frac{3}{8}$ -in. given is for the two smaller bobbins. For making larger bobbin, this should be enlarged to $\frac{1}{2}$ -in.

increased or decreased slightly, and helps to compensate for any slight error in counting the turns. The method of winding is of the simplest as is borne out by the illustration of this operation (see Fig. 8). Note that the wire is fairly tightly wound on the bobbin by the pressure of the fingers of the left hand.

A small hole is drilled in each bobbin to enable the beginning of the wire to pass to the outside where it can be twisted out of the way round the winder spindle. When the correct number of turns has been wound, secure the end and bind the coil with a strip of oiled silk or Empire cloth. It will be seen from Fig. 9 that the ends of wire all project at the shorter edges of the bobbins in order that they may not foul the laminations.

Fitting the Core.

Six dozen pairs of Stalloy No. 4 transformer stampings are needed. As an air-gap is not required, the "U" and "T" pieces are arranged in an alternate fashion. Start by fitting a "T" piece at each side of the oblong hole. A "U" piece can now be laid so that its parallel limbs are in line with the thick leg of the "T." Fit another "T," this time from the opposite side so that its edges come flush

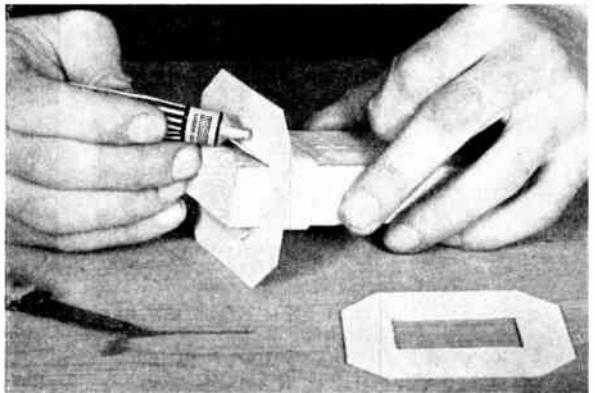

Fig. 5.—CONSTRUCTING THE TRANSFORMER BOBBINS.

Bend the piece of cardboard as marked out and cut in Figs. 2-4, and glue to form the centre of the bobbin cheeks as shown. A useful aid is the wood former seen above.

with the "U" piece in three places. A second "U" is laid in position with its centre limb over the top of the last "T." Now place a "T" and then a "U" in position from the other side of the bobbins. Repeat this process until the hole is completely filled. If the laminations are still loose, they can be tightened by driving in a thin wedge of wood at one end. The fitting of the laminations is shown in Fig. 9.

Completing the Core.

The irregular exterior of the core can be remedied by hammering the laminations into line as illustrated in Fig. 10. There should be no appreciable gap where the edges of the two types of lamination meet.

The Top Cover and the Base.

The top of the instrument and its base each measure 10 in. long and 5 in. wide, and both are cut from planed deal of about $\frac{3}{4}$ in. thickness. After the corners have been rounded, three sides are channelled; into which grooves the perforated iron casing is ultimately secured. Each groove should be about $\frac{3}{8}$ in. from the adjacent edge, $\frac{1}{16}$ in. wide, and $\frac{1}{8}$ in. deep. There are a number of ways in which these grooves

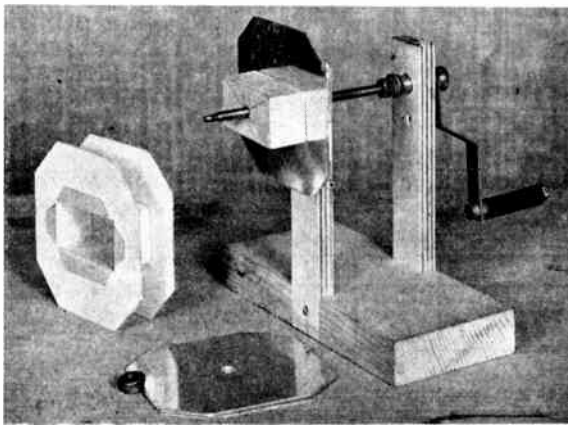

Fig. 6.—A SIMPLE WINDER FOR WINDING COILS ON TRANSFORMER BOBBINS.

A completed bobbin will be seen in the above picture.

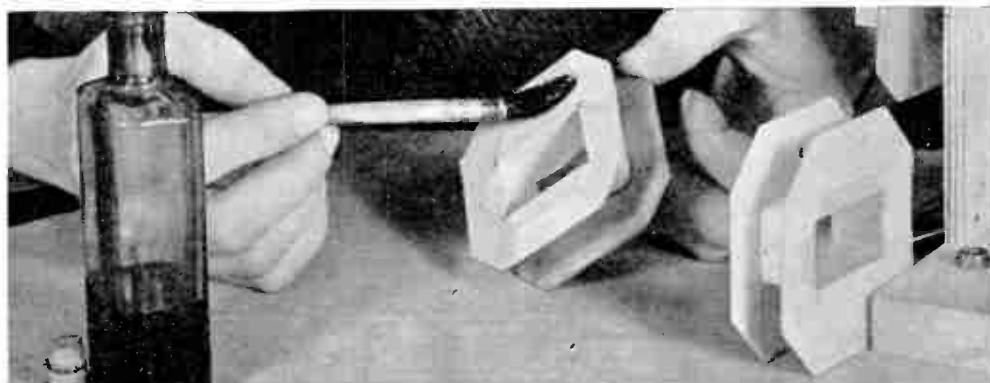

Fig. 7.—SHELLACKING THE BOBBINS BEFORE WINDING THE COILS.



Fig. 8.—A METHOD THAT MAY BE USED FOR WINDING TRANSFORMER COILS.



Fig. 9.—FITTING THE CORE WHEN MAKING THE TRANSFORMER.

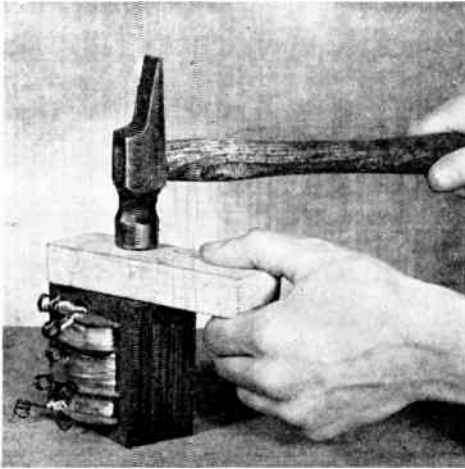

Fig. 10.—EVENING UP THE TRANSFORMER CORE LAMINATIONS.

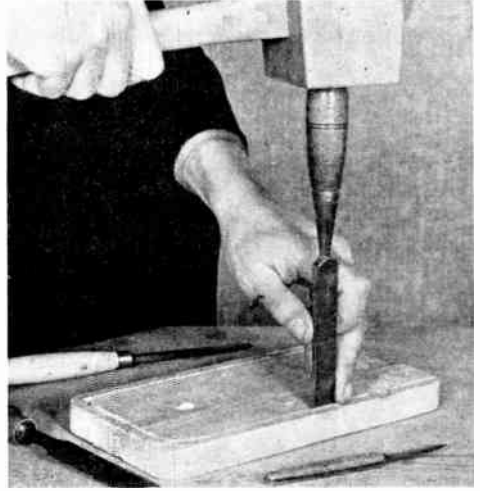

Fig. 11.—METHOD OF CHANNELLING WOOD FOR TOP COVER AND BASE OF INSTRUMENT.

may be made. The method illustrated in Fig. 11 employs a sharp wood chisel and a mallet, the centre piece being prised out with a pen-knife. For the rounded portions, a narrow chisel is used. The ends of the groove need not be extended to the extreme edge of the top or base, as they will be covered up when the end piece is fitted.

The Two Upright Members.

Both these pieces are cut from the same material as the base. The width is exactly that of the inside measurements of the grooves, whilst the height is $\frac{1}{16}$ in. more than the overall height of the jar selected for the rectifying cell. The writer used a 2-lb. jam jar in glass, of which the height was $5\frac{3}{8}$ in. In addition to forming a support for the top cover, the upright pieces serve to fix the transformer rigidly in position. The way in which this is done is clearly shown in Fig. 12. The transformer is raised from the base by two oblong blocks of wood whose outside edges come flush with the inside of the chan-

nelling. Two similar strips are screwed to the inside faces of the uprights in such a position that they press upon the laminations when the uprights are screwed into position from the underside of the base. The vertical end piece should be about $\frac{1}{4}$ in. from the edge of the base.

The Remaining Woodwork.

In order to locate the position of the jar, a ring of wood, of $\frac{1}{4}$ in. thickness, is cut to fit the bottom of the cell, its exterior shape conforming to the contour of the inside edges of the base channelling. A 5-ampere mains switch and two substantial terminals are fitted to the end piece as shown in the photographs, while a semi-circular cut is also made in the middle of the top of this piece. The mains cord passes through this gap and is firmly held when the top is fitted. If the stems of the terminals are not long enough to pass through the end piece, the latter must be recessed to allow for making electrical connection.

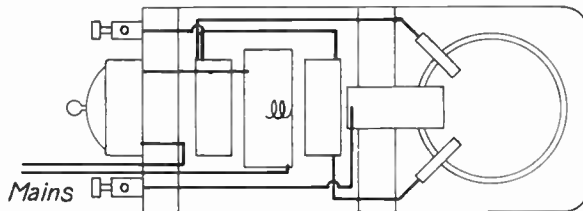

Fig. 11A.—PLAN VIEW OF WIRING.

The Electrodes.

A view of the inside of the part

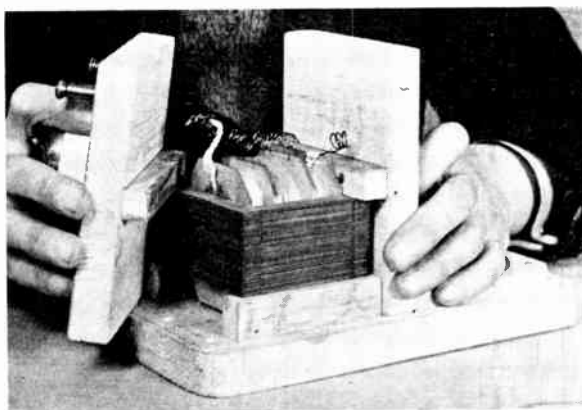

Fig. 12.—METHOD OF FIXING TRANSFORMER IN POSITION.

ly finished instrument is shown in Fig. 13. The jar has been removed to show the positions of the two strips of tantalum and the centre lead electrode. The latter is a strip of thin sheet lead, as used by builders for outside work, and measures $9\frac{1}{2}$ in. long and 1 in. wide. The submerged part is corrugated to provide a larger surface to the electrolyte.

Another view of the lead strip is seen in Fig. 14, in which the wiring has been completed. It will be noticed that the lead is drilled and bent over into the transformer compartment for con-

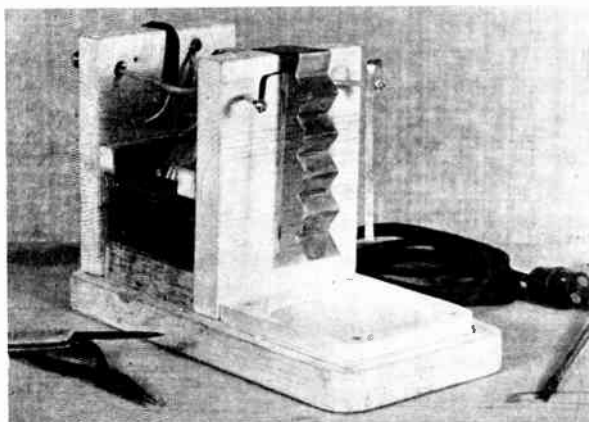

Fig. 13—VIEW OF PARTLY FINISHED INSTRUMENT, SHOWING POSITION OF ELECTRODES.

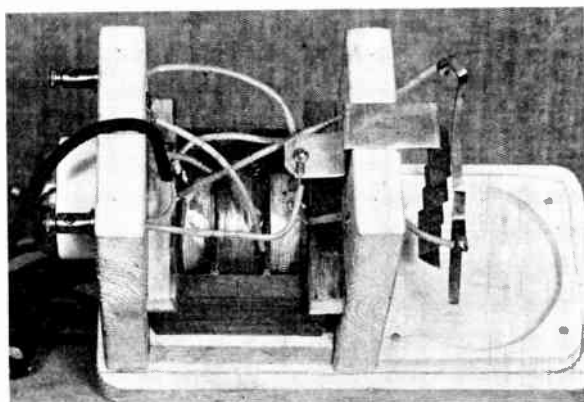

Fig. 14.—INSTRUMENT WITH WIRING COMPLETED.

tion to the negative terminal. The tantalum strips measure 5 in. by $1\frac{1}{8}$ in. A No. 6 B.A. hole is drilled at the extreme top end of each strip so that the connecting wire may be joined by a short nut and bolt. It is not possible to solder this metal.

The tantalum strips are bent over at the top of the jar and are supported by their connecting wires which pass through holes drilled conveniently through the centre partition. All connecting wires should be well covered with systoflex to prevent attack by acid fumes. At the junction of

the tantalum and its connections, acid-proof paint should be liberally applied. The success of the charger will depend largely upon the care taken in isolating the leads to the tantalum strips from acid. The possibility of this is rendered extremely remote by fitting a rubber washer tightly over the top of the jar and carrying an outlet pipe clear of the internal connections.

Impregnating the Woodwork.

All interior woodwork should be impregnated with paraffin

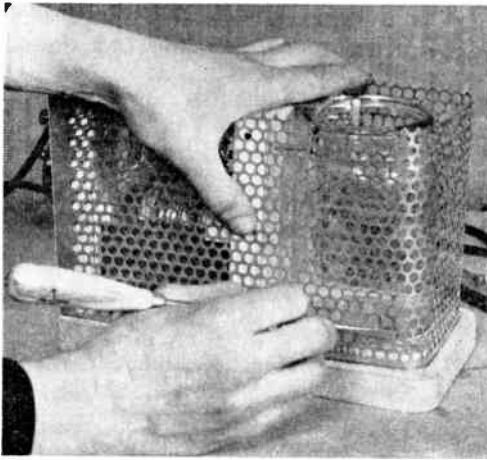

Fig. 15.—FITTING THE PERFORATED IRON SIDES.

Before the final assembly the iron is painted inside and outside.

wax. A convenient way of effecting this is to melt the wax with a hot soldering iron and to allow it to flow into the corners. The exterior is painted at a later stage with a cellulose enamel or with acid-proof paint.

Wiring the Charger.

A plan view of the wiring is given in Fig. 11A. Assuming that the two smaller secondary coils are mounted so that the turns run in the same direction, then the end of one bobbin will join to the beginning of the other. If a direct current were now passed through both coils the current should not change its direction. The junction of these two coils is taken direct to the positive charging terminal. One of the mains leads goes direct to the mains

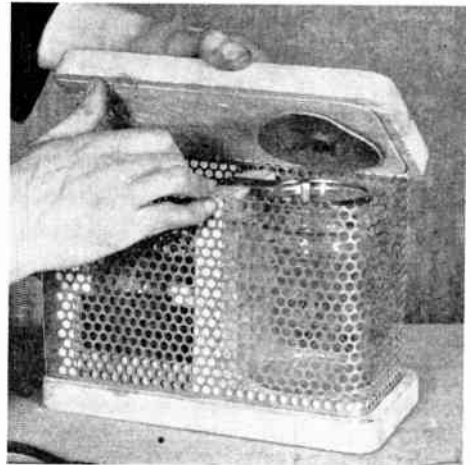

Fig. 16.—FITTING TOP TO INSTRUMENT. This shows clearly the rubber seal for cell to prevent corrosion of metal parts of charger, and the tube for topping up.

switch, while the other lead joins to one wire from the centre bobbin. It is convenient to anchor these two wires under a screw and washer to the inside of the end piece.

The Perforated Iron Sides.

The exact dimensions for the perforated iron will depend upon the radius of the corners of the channelling and the length, while the height is determined by the height of the vertical pieces and

the depth of the channelling. When the radial bends have been made, the iron is slipped into the groove at the bottom as shown in Fig. 15, in which a screwdriver, engaged in one of the perforations, is used to force the metal into position. Before the final assembly, the iron is painted inside and outside.

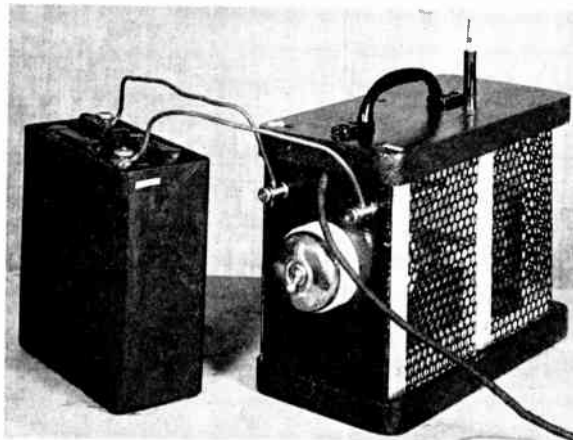

Fig. 17.—ELECTROLYTIC CHARGER IN USE, CONNECTED TO A MOTOR-CYCLE ACCUMULATOR.

Making the Cell Watertight.

If the measurements have been made correctly, there should be a space of about $\frac{1}{16}$ in. between the top of the jar and the underside of the top cover. A large rubber disc cut from an old motor car tube is intended to fill this gap and by pressing tightly on the rim of the jar to prevent the egress of acid or its fumes. An outlet is provided by fitting an ebonite tube of $\frac{1}{2}$ in. diameter through the top cover. This tube will serve for filling the cell or for topping up occasionally with distilled water. The tube and rubber disc are clearly seen in Fig. 16, where the top cover is being lowered into position. Note that the disc is sprung round the lower end of the tube by means of a small centre hole. If the pressure of the rubber is insufficient, the cell can be raised slightly by standing it on another rubber disc.

The Final Details.

Substantial brass screws are used to fix the top cover to the upright pieces. Brass screws should be used throughout in the construction work as they are less liable to corrosion.

A metal carrying handle is screwed to the top cover over the transformer, in which position the balance is preserved.

Positive and negative signs are attached to their appropriate terminals.

A very useful addition is a float arranged to project through the outlet tube with the object of indicating the acid level at a glance. It consists of a wooden skewer about 7 in. long and of a diameter allowing it to pass through the tube fairly easily. The diameter is reduced to about $\frac{1}{8}$ in. throughout half the length, the narrowed part projecting through the tube. It should be well sandpapered and treated with paraffin wax.

The Electrolyte.

The electrolyte is diluted sulphuric acid of S.G. 1.250, into which is dropped ferro-sulphate crystals or some iron nails until the solution is saturated.

The appearance of the completed charger is improved by screwing aluminium strips over the edges of the two upright pieces.

These are shown in Fig. 17 illustrating the electrolytic charger connected to a motor-cycle accumulator.

Determining the Charging Rate.

It is advisable to wire an ammeter in series with the accumulator on first using the charger to make certain that the charge is not excessive. If the battery is run down considerably the charging rate will be high until the back E.M.F. is built up. The rate can easily be reduced by using coiled resistance wire as connecting leads. The instrument will give a slightly greater output when the electrolyte is warmed by usage. The jar should not become excessively hot, while the rise in temperature of the transformer should be negligible. It will be noticed that the lead electrode becomes a rich brown in colour when formed, a process which takes about 10 minutes the first time the instrument is used. The acid level is maintained with the addition of distilled water at about $1\frac{1}{2}$ in. below the rim of the cell.

Obtaining the Materials.

No difficulty should be experienced in obtaining the materials used in construction with the exception of the metal tantalum. This can be obtained directly from Messrs. Blackwell's Metallurgical Works, Ltd., Speke Road Works, Garston, Liverpool.

TABLE OF TRANSFORMER WINDINGS.

Mains Voltage 40-60 Cycle A.C.	No. of Turns Primary Bobbin.	No. of Turns at Tapping.	Wire Gauge.
100	600	550	24 D.C.C.
110	660	605	24 D.C.C.
120	720	660	24 Enamel
130	780	715	24 Enamel
200	1,200	1,100	28 D.C.C.
210	1,260	1,155	28 D.C.C.
220	1,320	1,210	28 Enamel
230	1,380	1,265	28 Enamel
240	1,440	1,320	28 Enamel
250	1,500	1,375	28 Enamel

Each secondary bobbin has 90 turns No. 20 gauge single cotton on enamel wire.

A NEW METHOD OF CONTROLLING MODEL A.C. LOCOMOTIVES

By HENRY GREENLY, A.I.Loco.E.

After describing the past methods used for the control of models working on D.C. and A.C., Mr. Greenly gives details of a new system for A.C. supply. This employs the method of superimposing a low voltage direct current on the rail supply

THE gradual change over from direct current house supply to the A.C. system is making a considerable difference in the methods employed in arranging for the power and control of model railways.

Past Method of Power Supply — Direct Current.

In the past equipments have been designed for a normal line voltage of 4 to 6 volts direct current, supplied to the rails through a commutating switch for reversing and a rheostat for speed control. Although the advantages of a higher voltage were known, the expense of cells to supply 25 volts, or the installation of a rotary converter, kept the voltage for models to the lower figure of 6 volts.

Introduction of A.C. Supply.

A.C. transformers are now made by reputable manufacturers for 20 volts, 1 and 2 amperes output, and traction motors are standardised to suit this pressure. The higher voltage has resulted

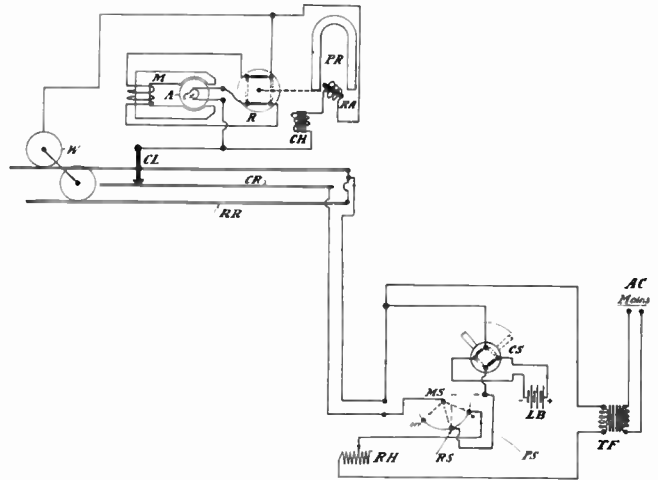

Fig. 1.—D.C. REVERSING CONTROL OF A.C. MODEL ENGINE MOTORS.

Diagram showing electrical connections and instruments necessary to provide distant-control of model electric locomotives working off the A.C. mains. *Loco Equipment* :—RR Running Rails; CR, Centre Conductor Rail; CL, Collecting Shoe; W, Wheels forming the "earth" circuit through the running rails; M, Main Traction Motor; A, Armature of Motor; C, Commutator of Motor; R, Reversing Switch; double dotted lines show connections in reverse; CH, A.C. Choking Coil; PR, Polarised Relay; RA, Relay Armature. *Line-side Control Box* :—TF, Power Circuit Transformer (220 v. to 20 v.); CS, Direction Selector Switch; MS, Main Switch; RS, Reversing Stud; PS, Power Stud; LB, Local (D.C.) Battery; RH, Rheostat for speed control.

in very much improved collection of current from the conductor rails and the series-wound motors specially designed with laminated field-magnets have characteristics which are eminently suited to traction purposes. The torque is heavy at starting and the amperage consumed falls at the higher speeds.

Difficulties with Reversing the Locomotive with A.C.

The A.C. supply up to the present has, however, rendered impracticable the reversing of the locomotive from the line-side control switch and many users therefore will not adopt the system in spite of its greater economies and the convenience of being able to plug in to any electric light socket near to the model line.

Disadvantages of the Sequence Reverser.

The "sequence reverser," an electro-mechanical device which moved the reversing switch on the locomotive round one peg, i.e., from forward to reverse and

reverse to forward every time the current was shut off and reapplied, gave considerable trouble. At any time a break occurred in the collection of the current from the rails, due to a jar at points and crossings or the incidence of a patch of dirt on the rail, the locomotive was in danger of being inadvertently reversed in direction of travel.

Drawbacks of Hand Reverser.

The latest motor mechanisms made for No. 0 (1¼-in.) gauge model railways are therefore constructed with a hand reverser only, which in a finished engine is operated by a push-rod from the cab. The line-side control box only comprises

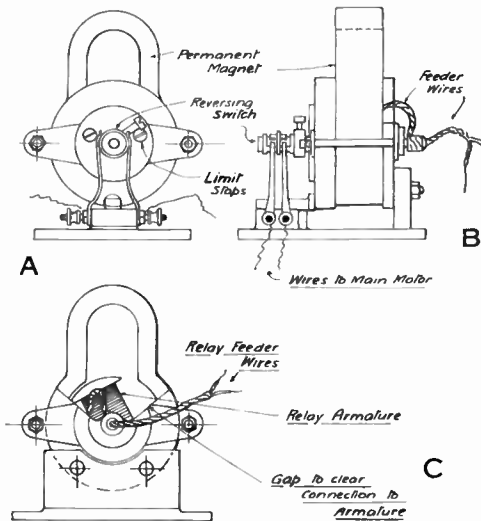

Fig. 2.—THE POLARISED RELAY REVERSING INSTRUMENT. (A) Reversing switch end; (B) Side view; (C) Armature feeder wire end.

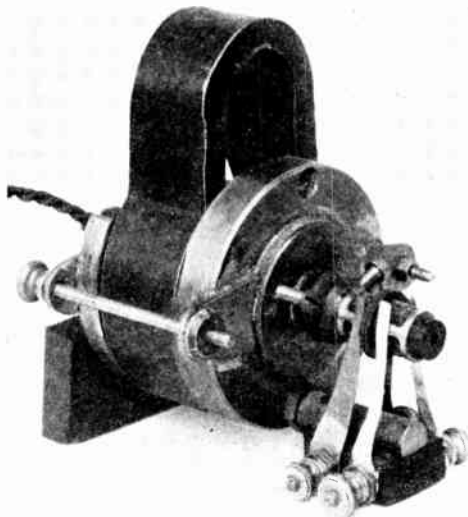

Fig. 3.—RELAY SHOWING REVERSING SWITCH (R, Fig. 1).

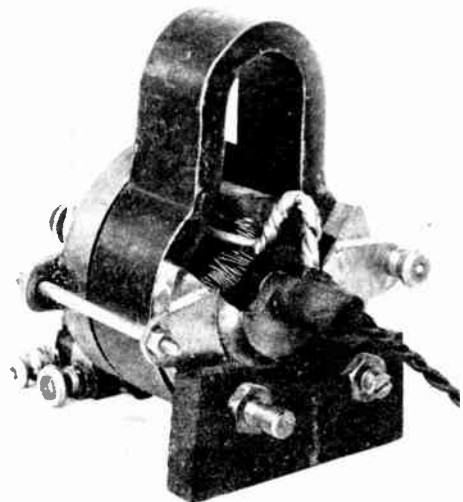

Fig. 4.—FEEDER END OF RELAY.

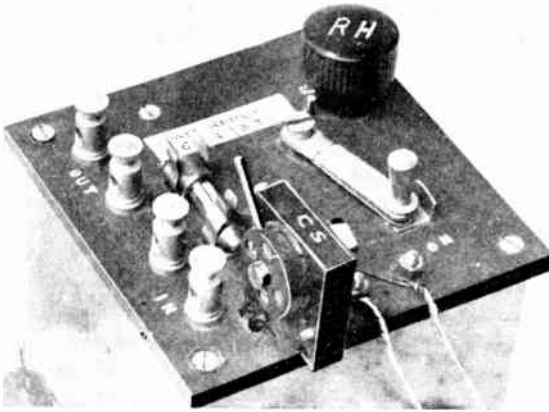

Fig. 5.—CONTROL PANEL OF THE REVERSING RELAY. Showing three main controls:—RH, Speed Regulation Rheostat; Main Switch; CS, Selector Switch for reversing, and wires to local control battery.

an "on" and "off" switch and a variable resistance for speed regulation with, of course, the necessary terminals for the connection of the transformer and a fuse. In using this form of control the operator must leave his station if he wishes to reverse a distant engine.

A New Reversing Scheme.

The newly invented reversing scheme which has been the outcome of experiments by the writer gets over this difficulty of reversing control.

By imposing a D.C. control current on the same wires as those carrying the A.C. power circuit, a polarised relay can be operated on the locomotive, through the rails from the control box, which relay will mechanically operate the reversing switch on the engine. The reversing switch only needs one watt to move it and therefore the voltage can be low. For practical reasons—to break down any dirty connection on the running rails, collector and conductor rail, at least 4 volts should be used. The relay may therefore be quite inefficient as an electrical instrument for other reasons to be explained later and take quite a large D.C. current.

How it Works.

To protect the local D.C. battery at the line-side control from the effects of the

higher voltage alternating power current it is arranged that only one current is flowing at any time, not both. The main switch has the usual "off" point and in its path to the A.C. power stud sweeps across a rather long stud connecting the D.C. local battery. During this contact the direct current, the direction of flow is determined by a pre-selecting switch, passes along to the locomotive. The selector switch also controls the movement of the permanent magnet relay device in the locomotive. If it is already in the forward position and the pre-

selection switch on the control board is set to "reverse," then the direction of the local battery current is such that the relay armature turns the reversing switch on the engine over to required reverse position. The same action takes place when it is desired to change from the reverse to the forward direction. When no alteration is required the current flows, but of course has no other effect but to ensure that the

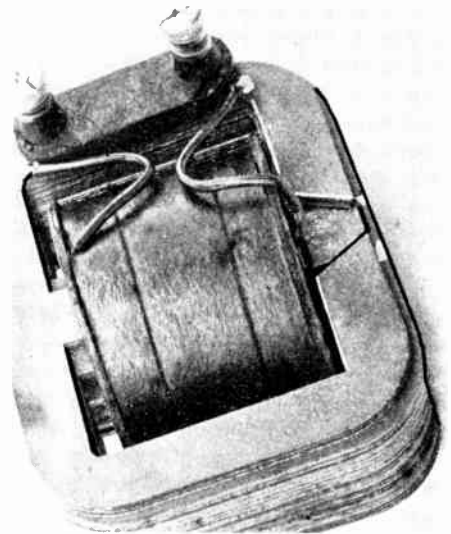

Fig. 6.—CHOKING COIL PLACED IN POLARISED REVERSING RELAY SHUNT CIRCUIT.

relay is in the right position before the A.C. power circuit is switched on.

Equipment on the Locomotive.

As on the model locomotive the polarised relay is in parallel to the main power circuit, it is desirable to protect it and at the same time to impede, as far as possible, the flow of A.C. current through the windings of the relay armature. Therefore an essential part of the circuit is, as shown in the theoretical diagram Fig. 1, a low D.C. resistance choking coil. In the experimental apparatus a Ferranti standard B7 choke was employed and even with a relatively efficient polarised relay which would operate on .5 to .75 watt at 2 volts the full voltage (20 v.) alternating power supply passed so little magnetising current through the armature that for final use in a No. 0 gauge model a much smaller choke can be installed. The B7 choke has a D.C. resistance of 1.4

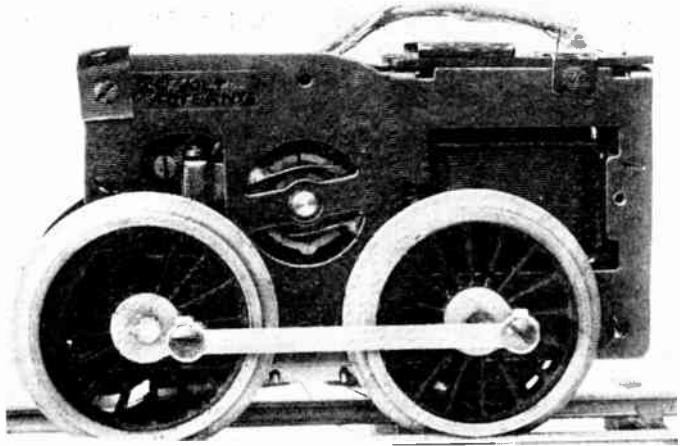

Fig. 7.—20 v. ALTERNATING STANDARD MOTOR MECHANISM TO WHICH THE SUPERIMPOSED D.C. REVERSING CONTROL WAS APPLIED.

this magnet and its moving armature to reduce the flux. The momentary excess of D.C. control current which will follow the increase of voltage supplied from a local battery—an increase necessary to the breaking down of any dirt at the rail collection contacts—will allow a lesser number of turns to be used in the relay armature windings. There is nothing against the use of a relay requiring three or four watts to move it.

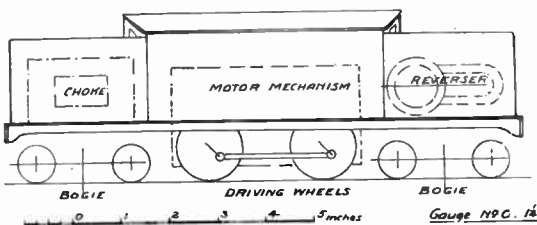

Fig. 8.—A PRACTICAL ARRANGEMENT OF THE REVERSING SCHEME IN A MODEL ELECTRIC LOCOMOTIVE OF THE I.N.E.R. TYPE.

ohms and a limiting current of 1 ampere. On 20 volts 50 cycles A.C. the alternating current that is passing is not more than one-tenth of an ampere, and the inductance ranges between .075 and .28 henry. This current has hardly any effect on the permanent magnet of the relay and it is possible to increase the air gap between

Construction of the Relay Reverser.

The relay reverser magnet was fitted with end-bearing discs carrying an "H" armature made up of seventeen .015-in. standard 1½-in. stampings. The spindle carries a barrel-type reversing switch as shown in Fig. 3, of the finished instrument. The use of slip rings to feed the current to armature windings was eliminated. As the armature only rotates through an arc of 90° the wires were connected to a silk covered flex and brought out through an insulating fibre nipple fixed on the other end of the spindle. The armature of the reverser is wound with No. 22 gauge wire. Four brushes are required to collect the A.C. power current from the reverser contacts.

A POWERFUL GRAMOPHONE AMPLIFIER

By S. A. HURREN and G. A. CRICKSHANK

In this article, the authors describe how to construct a gramophone amplifier. By the addition of a detector valve and H.F. amplifier, the set may be formed into a radiogram. Another possibility is the use of the amplifier for public announcements by microphone

EXPERIENCE has shown that for the proper reproduction of gramophone records the power output that needed for radio purposes, in order to give adequate volume. In the following article is described an amplifier to give this volume. It can be thoroughly recommended to anyone who wishes to build a powerful, yet distortionless, instrument for the reproduction of gramophone records. Primarily intended for this purpose, provision has been made for the connection of a detector valve, which may itself be preceded by a high frequency amplifier, thus forming a very powerful radiogram.

The Circuit Diagram.

The diagram shows that the complete design is straightforward and easy of construction. The components used, with the exception of the bias resistors, are standard, being obtainable from any good wireless dealer. They are all of high quality and guaranteed, so that there is little likelihood of the amplifier being "out of action" for long periods while some nondescript component is going backward and forward between the retailer and manufacturer.

The General Scheme.

The lay-out followed was adopted to render interaction between components as small as possible. It is important to earth the metal frames of the gramophone motors at the point indicated by the makers, or a certain amount of hum may be noticeable when the volume control is full open and no record being played. The pick-up leads are screened, and this screening earthed. The negative high tension is also earthed, as are the transformer cores, and although the amplifier will work without an earth, it is highly advisable to earth it, so as to lessen the risk of hum or crackling.

Perhaps the simplest way to describe the amplifier is to say that a pick-up is connected through a step-up transformer to the first valve, which is transformer-coupled to the two output valves in push-pull, these output valves operating a moving-coil loudspeaker through a stepdown transformer.

CONSTRUCTIONAL DETAILS.

We will now consider the amplifier in detail. The instrument is housed in a large cabinet, made of oak, the panels being an inch thick, the front acting as a

A LIST OF COMPONENTS.

- 2 gramophone motors (Garrard No. 201 A.C. induction).
- 2 pick-ups (B.T.H. Minor).
- 1 fader, 50,000 ohms (Clarostat).
- 1 pick-up transformer (Varley D.P.3).
- 1 double push-pull input transformer (Varley D.P.17).
- 1 output transformer (Varley D.P.7).
- 1 mains transformer (Varley E.P.24).
- 1 variable resistance, 1 meg.
- 1 50,000-ohm resistance (Tag).
- 2 5,000-ohm resistances (Tag).
- 4 200-ohm resistances (Tag).
- 1 30,000-ohm resistance.
- 1 20-ohm "Humdinger" resistance.
- 1 0.001-mfd. condenser.
- 2 4-mfd. condensers.
- 3 2-mfd. decoupling condensers (Ferranti, 750-volt test).
- 1 smoothing choke (Varley D.P. 30).
- 1 A.C./H.L. Mazda valve.
- 2 P.P. 5/400 Mazda valves.
- 1 U.U. 120/500 Mazda valve.
- 1 thermal delay switch (Bulgin).
- 1 moving coil speaker (B.T.H. Senior).
- 1 Westinghouse metal rectifier.
- 1 4-mfd. condenser.
- Baseboard, 10-ply.
- 2 mains fuses.
- 1 mains switch.
- Valve holders (Benjamin anti-microphonic).
- 1 500-ohm resistor (1 watt).
- 1 270-ohm resistor (5 watts).

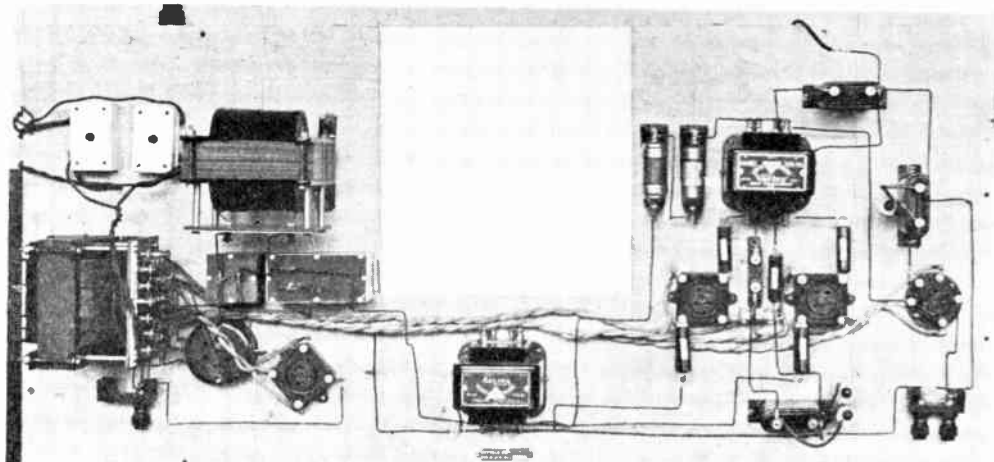

Fig. 2.—ILLUSTRATING ASSEMBLY OF COMPONENTS ON BASEBOARD.

necessary. The double bass and drums come out very "forward" in this way. With the exception of the mains switch, and two small lamps run off one of the low voltage secondaries of the mains transformer, all the rest of the components are located on the baseboard shown in the photograph. It is fixed at the bottom of the cabinet, and is easily removable by unscrewing a few screws when access to the components is required.

Shielded Leads.

Shielded leads are taken from the secondary of the pick-up transformer down to the two terminals seen at the bottom right-hand corner of the photograph; these connections feed into the grid of the first amplifying valve (Mazda AC/III), the bias for which is derived from a resistance of 500 ohms (R_2) in its cathode lead, decoupled by a 2 mfd. condenser (C_1).

Anode Circuit of First Amplifying Valve.

In the anode circuit of this valve is one primary of a Varley double push-pull input transformer (T_2) decoupled by a 50,000 ohms resistance (R_3 , Varley Power) and a 2 mfd. condenser (C_2), the decoupling resistance also serving to drop the high voltage supplied by the rectifier down to the 200 volts required for the high tension supply to this valve. The other primary

of the transformer (T_2) can be used for connection of a detector for radio, as mentioned earlier, or for connection of a microphone and associated amplifier for announcements or public address. The list title of this transformer is D.P.17.

The Output Stage.

We now come to the output, probably the most important stage of any amplifier, whether "gram" or radio, for it is here that losses are liable to occur if matching is not correct or if overloading is allowed.

The Push-pull Valves.

The push-pull input transformer has a split secondary, and separate bias may be used for each of the pair of push-pull valves if necessary. The circuit followed is that recommended by the valve makers, the valves in use being Mazda PP 5/400. The resistance and condenser values specified have been adhered to carefully. This is most important, as otherwise parasitic oscillation is likely to occur, with consequent damage if not actual destruction of the valves. The grid and anode circuits both have anti-oscillation resistances, of 5,000 (R_7 and R_8) and 100 (R_9 and R_{10}) ohms. As the anode current of the PP 5/400 is 60 milliamps., and a single 100 ohm tag is only rated to carry 50 milliamps., it is advisable to connect two

200 ohm tags in parallel, thus forming a 100 ohm resistor capable of carrying up to 90 milliamps. These resistances, as will be seen from the photograph of the amplifier, are connected directly to the appropriate terminals on the valve holders.

The Output Transformer.

The output transformer (T3) is a Varley push-pull output double ratio, D.P. 7, having ratios of 1 : 1 and 20 : 1, the latter ratio being used. The moving-coil speaker is a B.T.H. Senior, with a Westinghouse metal rectifier and a 4 mfd. smoothing condenser incorporated for field energising. The speaker has an impedance of 15 ohms. The equation for loud-speaker matching is:—

$$N = \sqrt{\frac{\text{Optimum load of valve} \times 2}{\text{Speaker impedance}}}$$

where N is the transformer ratio, and the multiplier 2 is used because with valves in push-pull their impedances are in series. This gives us:—

$$N = \sqrt{\frac{2,700 \times 2}{15}} = \sqrt{360} = 19$$

That is to say, we require a transformer with a 19 to 1 step-down ratio, and the standard 20 to 1 ratio given by the Varley component is therefore nearly correct. The filaments of the output valves are heated with raw alternating current from one of the 4-volt secondaries on the mains transformer (cd). The 270-ohm bias resistor (R5) specially wound to this valve is connected between H.T. negative and the centre point of the filament supply as located on a 20-ohm "Humdinger" across the filament winding. The centre-tap of the input transformer is at earth potential, so that the voltage drop across this resistance, caused by the anode current of 120 milliamps., amounts to 32.4 volts, and gives the requisite negative grid bias for the valves.

Output of the Valves.

The two valves in push-pull give an undistorted output of 12.5 watts, and the loud-speaker is capable of handling 10 watts. There is sufficient power to work two loud-speakers of this type, and if the amplifier is to be used in a large hall an extra speaker correctly matched

would be an advantage. Four speakers connected in series-parallel could be used.

THE POWER SUPPLY.

The power supply for an amplifier of this size needs very careful attention. The mains transformer used should have a good "regulation curve." The Varley (E.P. 24) 120 watt has several 4-volt windings for filament heating. The rectifying valve is a Mazda UU 120/500, which, as its name implies, gives 120 milliamps. at 500 volts. The output valves require 400 volts high tension, so that there is sufficient surplus voltage for the grid bias, and for voltage drop in the smoothing choke, output transformer primary and anode anti-oscillation resistances. The smoothing choke (CH) is large, a Varley D.P. 30, and has an inductance of some 13 henrys at the 120 milliamps. passing through it. The 4-mfd. smoothing condensers shown in the picture are Hydra, but the one on the left, immediately following the rectifier, is now an 800-volt (working) Dubilier. A Bulgin thermal delay switch (T.D.S.) is fitted in the conventional position serving to prevent the high tension reaching the valve anodes before the filaments are properly warm, and preventing dangerous surges through the condensers, thus lessening the likelihood of breakdown.

The decoupling condensers (C₁, C₂, C₃) are Ferranti 2 mfd., 750 volt test, correct for their positions.

Fuses are, of course, inserted, one in each mains lead.

The Baseboard.

The baseboard is of 10-ply, giving the necessary rigidity to carry the heavy components, the smoothing choke alone weighing over 9 lb. From the photograph it will be seen that this baseboard is cut away, allowing it to fit around the supports for the moving-coil speaker, which is supported on a stand built into the base of the cabinet, to prevent rattle or vibration. Heavy workshop flex is used for the filament heater leads, and separate runs are taken to each valve to prevent voltage drop in these leads. The valve holders are Benjamin anti-microphonic.

Correspondence

The Editor invites correspondence from readers on any subject of general interest to members of the electrical engineering profession. Letters should be addressed to THE EDITOR, The Practical Electrical Engineer, 8-11, Southampton Street, Strand, W.C.2.

Details of an Electrolytic Rectifier.

SIR.—I should be glad if one of your readers can give details of an electrolytic rectifier suitable for supplying the high tension current for a three-valve receiver.

A. J. (Fulham).

All the necessary details for the construction of an electrolytic rectifier for H.T. supply are given below. The rectifier has been supplying a three-valve set, det., L.F. and power, for some weeks and it has given very satisfactory service.

Materials required:—

Electrodes—6 in. \times $\frac{1}{4}$ in. aluminium rod, 4 only; 6 in. \times $1\frac{1}{4}$ in. \times $\frac{1}{8}$ in. lead strips, 4 only.

Electrolyte—Pure ammonium phosphate in distilled water, $1\frac{1}{2}$ lb. to 1 gallon.

Cells—2 lb. glass jam jars, 4 only.

The aluminium electrodes must first be formed as follows: Connect 2 aluminium electrodes in series with a 100-watt lamp and place them in a cell

containing electrolyte as above. Connect to 200-volt mains. After current has been passing for 15-20 minutes it will be seen that the lamp is completely extinguished. Forming is then complete. Forming was tried with other sized lamps, but did not succeed, hence it must be stressed that a 100-

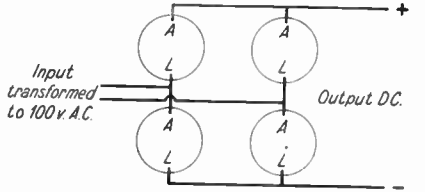

A - aluminium electrodes. L - lead electrodes
CIRCUIT DIAGRAM OF ELECTROLYTIC RECTIFIER.

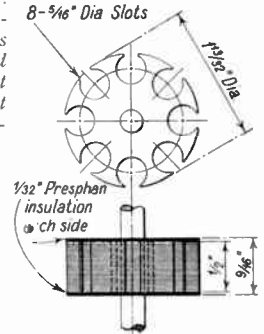

ARMATURE
ARMATURE OF SMALL MOTOR.

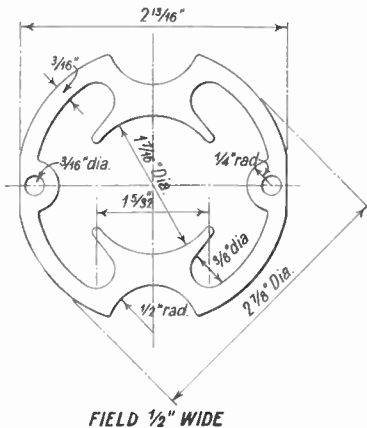

FIELD $\frac{1}{2}$ " WIDE
FIELD OF SMALL MOTOR.

watt lamp, or possibly one of lower resistance, be used.

The rectifier is then connected as shown in the theoretical circuit, bearing in mind the following points: Do not let electrodes rest on bottom of cells—a metallic sediment is deposited which may cause shorting if this is neglected. Cover electrolyte with thin layer of oil—preventing evaporation of electrolyte. Two aluminium and two lead electrodes may be in one portion. I made connections by drilling holes in electrodes and attaching terminals, but possibly a more efficient method exists.

Of course, the usual smoothing apparatus must be connected to output to eliminate ripples.

Re-Winding a Small Motor.

SIR.—I send herewith scale drawings of the field and armature of a small motor which I am desirous of re-winding as a high torque, low-speed machine.

Can you oblige me with winding data (a) for a 12-volt, D.C. or A.C. motor, max. torque at 500 r.p.m. (b) for 200 v. 50 v. A.C. motor, max. torque at 500 r.p.m. L.P. (Huddersfield).

THE BEST OF OPPORTUNITIES

More than 430,000 men have studied I.C.S. Electrical Courses since 1894. A very considerable percentage of them now hold important and well-paid positions. The reason for this is that these Courses are absolutely the best in the world, having been specially prepared and constantly revised for correspondence tuition by many experts of very high standing at a cost, exclusive of printing, of more than £80,000.

If you wish to make rapid progress in the wonderful and fascinating field of electricity, you owe it to yourself to obtain all particulars of I.C.S. Training and what it can do for you. Among our Courses are the following:—

Complete Electrical Engineering	Engine and Dynamo Running
Electrical Designers	Lift Operation and Maintenance
Hydro-Electric	Water-Power Electrical
Electric Lighting	Mining Electrical
Electric Traction	Practical Telephony
Steam Electric	Wireless Engineering
Gas Electric	Professional Exams.

Write to-day for our 80-page FREE BOOKLET,

“**ELECTRICAL ENGINEERING**” stating the subject in which you are most interested

International Correspondence Schools, Ltd.
238 International Bldgs., Kingsway, London, W.C.2

PITMAN'S PRACTICAL BOOKS

ELECTRICAL CONTRACTING ORGANIZATION & ROUTINE

By H. R. Taunton. This book discusses the duties of the various departments of the electrical contractor's business and gives practical information that will help to increase turnover and reduce overhead costs. It also makes a valuable contribution to the efficiency of the technical work.
342 pp., 12s. 6d. net.

ELECTRIC WIRING TABLES

By W. Perren Maycock, M.I.E.E., revised by F. C. Raphael, M.I.E.E. A handy collection of twenty-four tables for the use of engineers and all concerned with electrical installations for heating, power and lighting. The tables are accompanied by explanatory notes and useful details. Pocket size. Sixth Edition.
3s. 6d. net.

PRACTICAL ELECTRIC LIGHT FITTING

By F. C. Allsopp. A handbook on the wiring and fitting up of buildings deriving current from central station mains. It deals with lamps and fittings, heating and cooking appliances, testing, meters and wiring systems, etc. Tenth Edition.
7s. 6d. net.

SIR ISAAC PITMAN & SONS, LTD.,
PARKER ST., KINGSWAY, W.C.2

Indispensable to the Motorist

NEWNES' MOTORISTS' TOURING MAPS AND GAZETTEER

This new Road Guide of the British Isles contains 96 beautifully coloured Maps. The Class A main roads are clearly shown in Red and the Class B in green. Each road bears its appropriate Ministry of Transport number. *The new arterial roads are clearly indicated.*

These Maps have been specially prepared by Messrs. John Bartholomew & Son, Ltd., the world-famous cartographers, and are absolutely up to date.

They measure 9½" by 7½" each, and are mostly on the liberal scale of 4 miles to the inch, which is ideal for the motorist.

Altogether, the Maps form a complete survey of Great Britain and Ireland, and should be in the possession of every enthusiastic owner-driver.

Transparent flaps, marked in inch squares, are attached to the two front edges of the cover in such a way that they can be inserted in any part of the book

Price, £1. 1s.; or by post, £1. 1s. 9d.

NEWNES' MOTORISTS' TOURING MAPS

Contains same Maps as in above volume. Bound in Water-proof Leather Cloth, with Protecting Flap and Press Button

Price, 15s.; by post, 15s. 9d.

Published in conjunction with John Bartholomew & Son, Ltd., by

GEORGE NEWNES, LTD. 8-11 Southampton St., Strand, London, W.C.2

Geo Newnes, Ltd.

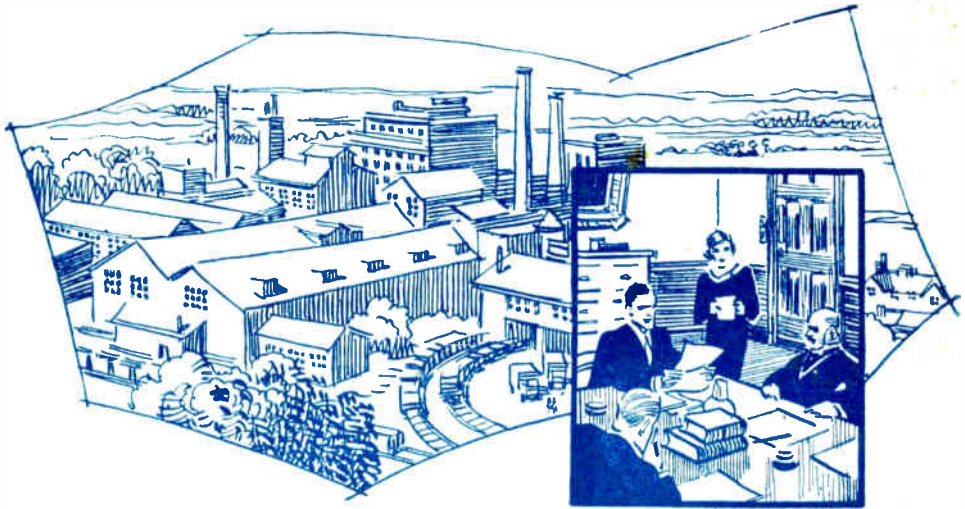

Business Building

Every ambitious young man commencing his business career dreams of the time when he, in his turn, will be a Business Builder. If he is shrewd as well as ambitious he will make certain that his future is laid on the foundation of a sound business knowledge.

The mere specialist will never reach the high-salaried executive positions. These are won only by men who have a trained knowledge of *every* branch of modern commercial practice.

You can obtain this vital information by studying "The 20th Century Business Practice"—an entirely new and practical

guide to efficiency—written by Lord Riddell, Sir Herbert Austin, Sir Sidney M. Skinner, Mr. Wilfrid T. Fry, Sir William Schooling and many other leaders of commerce, who unveil for you the inner secrets of Commercial Management, Manufacturing, Importing and Exporting, Departmental Stores, Advertising, Company Law—in fact, all branches of a live commercial undertaking.

"The 20th Century Business Practice" is complete in Six Volumes, and contains many coloured maps, photographs and specimen documents of immense practical value.

20TH CENTURY LOOSE-LEAF BUSINESS PRACTICE

SEND P. C. TO-DAY
FOR FREE
DESCRIPTIVE
BOOKLET and
DETAILS of OUR
GENEROUSEASY
PURCHASE
SCHEME to the
HOME LIBRARY
BOOK CO..
Dept. P.E.E. 633
23-24 Tavistock St., Covent
Garden, London, W.C.2.

Geo. Newnes Ltd.

Printed in Great Britain for the Proprietors, GEORGE NEWNES, LTD., 8-11, Southampton Street, Strand, W.C.2, by WILLIAMS, LAM & CO., LTD., Clifton House, Worship Street, E.C.2. Sole Agents: Australasia: GORDON & GORCH Australasia), Ltd. South Africa: CENTRAL NEWS AGENCY, LTD.