

Practical Computing

May 1981

Volume 4 Issue 5



Thinking Systems

Reviews:

Equinox and MVT Famos

Sharp MZ-80K

Versawriter

Wordease

Network choices

Backgammon game

Stock control

Convert 6502 to Z-80 code

MicroCentre introduce System Zero

Basic System Zero £587
System Zero/D with DDF £2355

The System Zero is a small computer especially designed for dedicated applications. It is particularly useful in process control situations.

In the basic model you get Cromemco's famous Z-80A single card computer, 1k of RAM, 4k of ROM, Control Basic, and an attractive cabinet. The motherboard provides 3 extra card slots on the S-100 bus, for tailoring the system to particular applications. The basic model is designed for ROM-based programs, but it can be expanded by the addition of memory and I/O cards. It is fully compatible with all Cromemco peripherals, including floppy disks and hard disk systems. Suitably configured the System Zero can run any Cromemco operating system or software package.



New System Zero Computer with quad-capacity DDF disk drive. The system includes built-in diagnostics for a quick system test of memory, controller and disk drives

System Zero/D

This special version of the System Zero has 64k of fast RAM, and a model DDF dual disk drive. It includes two double-sided double-density 5 inch disk drives giving a total of 780k bytes storage; and RDOS-2, a new resident disk operating system with terminal and printer drivers, and self-test diagnostics.

The System Zero/D is an exceedingly inexpensive development computer ideal for setting up dedicated applications to run in the basic model. It will support Cobol, Fortran IV, Ratfor, Structured Basic, Lisp, RPG II, Word Processing, DBMS, and the full range of Cromemco's business applications software.

Operating system

The System Zero/D will run any Cromemco operating system provided sufficient memory is available. The minimum configuration of 4k ROM runs control Basic; with 64k RAM the system will run RDOS-2 or CDOS (compatible with CP/M); and with 128k the Zero/D will run the Cromix system (based on Unix).



At the recent UK launch of the System Zero Computer, Cromemco's Technical Director Roger Melen presented a System Zero/D with 128k memory running Cromix. Here he is seen discussing the system with MicroCentre Director Andrew Smith (right).

For  Cromemco... call the experts

MicroCentre
Tel: 031-556 7354

**LEADING UK
DISTRIBUTORS**

Complete Micro Systems Ltd.,
30 Dundas Street
Edinburgh EH3 6JN

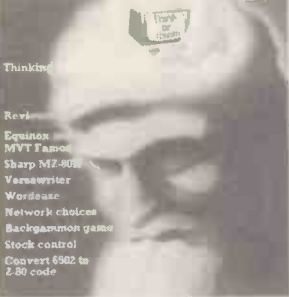

Thinking Systems — page 74.

Editor

Peter Laurie

Assistant Editor

Duncan Scot

Staff Writer

Bill Bennett

Production Editor

Toby Wolpe

Prestel Editor

Martin Hayman

Editorial Secretary

Tracy Ebbetts

Consultants

Technical **Nick Hampshire**

Software **Mike McDonald**

Editorial: 01-661 3500

Advertisement Manager

David Lake

Advertisement Executives

Philip Kirby

Ken Walford

Advertising: 01-661 3021

Midlands office:

David Harvett 021-356 4838

Northern office:

Ron Southall 061-872 8861

Publishing Director

Chris Hipwell

Published by IPC Electrical electronic Press Ltd, Quadrant House, The Quadrant, Sutton, Surrey, SM25AS. Tel: 01-661 3500. Telex/grams 892084 BIPRESG.

Typesetting and artwork by Bow-Towning Ltd, London EC1
Printed by Eden Fisher Ltd, Southend-on-Sea

Distributed by IPC Sales and Distribution Ltd, 40 Bowling Green Lane, London EC1R 0NE

Subscriptions: U.K., £8 per annum; Overseas £14 per annum; airmail rates available on application to Subscription Manager, IPC Business Press (S & D) Ltd, Oakfield House, Perrymount Road, Haywards Heath, Sussex RH16 3DH, tel 0444 59188

© IPC Business Press Ltd 1981

ISSN 0141-5433

Would-be authors are welcome to send articles to the Editor but PC cannot undertake to return them. Payment is at £30 per published page. Programs intended for publication should ideally be justified to 22 or 44 or 66 characters per line.

Submissions should be typed or computer-printed. Hand-written material is liable to delay and error.

Every effort is made to check articles and listings but PC cannot guarantee that programs will run and can accept no responsibility for any errors.

CONTENTS

- 41** Editorial / Financing the future
- 42** Feedback / MuPet; educational software; recursion
- 46** Printout / Sinclair ZX-81; BBC and Acorn; Alf music boards
- 55** Wordease / The machine-coded word processor for Nascom and other Z-80 based systems
- 58** Equinox / David Watt reviews the Equinox and its partnership with MVT-Famos, the multi-user operating system
- 66** Sharp MZ-80K / An inspection, conducted by John Dawson, of the MZ-80K and its parade of peripherals
- 71** Versawriter II / The low-cost graphics tablet for Apple II
- 74** Thinking Systems / Economics and sociology are just two of the disciplines Boris Allan uses to illustrate his exploration of system concepts
- 81** Education / Robert Ferguson presents a trigonometry program
- 83** Applications / Computerisation in London's King's Road
- 85** Stock control / A Basic program
- 91** Micros at Marconi / Marconi proves that large-scale heavy industry does not only use mainframes
- 93** Network choices / Ethernet or Cambridge Ring?
- 96** Backgammon / This month's game
- 102** Duncan / Nascom 1's high-level interpreter
- 107** Pascal / This language can seriously damage your mental health — Raymond Anderson's warning
- 109** Z-80 Zodiac
- 110** ZX-80 Line-up
- 112** 6502 Special
- 119** Tandy Forum
- 120** Pet Corner
- 121** Apple Pie
- 122** Micromouse
- 123** User Groups
- 125** Book Reviews
- 126** 6502 to Z-80 code / The first of two articles by David Peckett on a 6502-to-Z-80 translator
- 132** Pet Disc / P Krueger's assessment
- 135** Software Buyers' Guide
- 147** The Hexadecimal Kid / Page 8 of Richard Forsyth's parable
- Prestel page number 45631

WAGES AND SALARIES

Is the payout costing you more than it should?

SUPERPAY and BASICPAY — two payroll systems from Computastore to cut the cost of payroll, whatever the size of your company.

Over the past two years Computastore Payroll systems have proved their effectiveness for over 300 companies — ranging in size from six employees to over a thousand.

Suitable for *all* types of PET and CBM Disk, Computastore's SUPERPAY and BASICPAY are the only Payroll Programs approved by Commodore.

SUPERPAY £350

- Easy to read departmental analysis with up to 20 rates of pay and adjustments, for up to 26 departments.
- Automatic printing of year end P60's, P11's and P35's.
- Automatic printing of credit transfers.
- Automatic increase of all tax codes for budget changes.
- Net Pay Rounding to any amount less than £10.
- PLUS all of BASICPAY's standard features.

BASICPAY £75

- Automatic calculation of Tax and NI for weekly, monthly, four weekly, or irregular payment periods.
- Automatic advancement of tax week for holiday periods.
- Automatic coin analysis for cash payments.
- Can produce individual payslips.
- Option to process all employee payslips automatically.
- Easy to install. Even newcomers to computers can use BASICPAY within a few hours.

Each program takes no more than 35 seconds per employee for build up to gross, net pay calculation, and printing a payslip in duplicate. That works out at only 2 hours each week for a typical payroll of 200, or just 15 minutes for a staff of 20.

SUPERPAY is designed for medium size companies which need a comprehensive, flexible, and easy to use payroll; BASICPAY is for small companies who want a flexible, low cost system which carries Commodore's seal of approval.

For the name of your local Computastore Agent, contact:



Computastore

Computing for Business

Computastore Ltd., 16 John Dalton St., Manchester M2 6HG. Tel: 061-832 4761

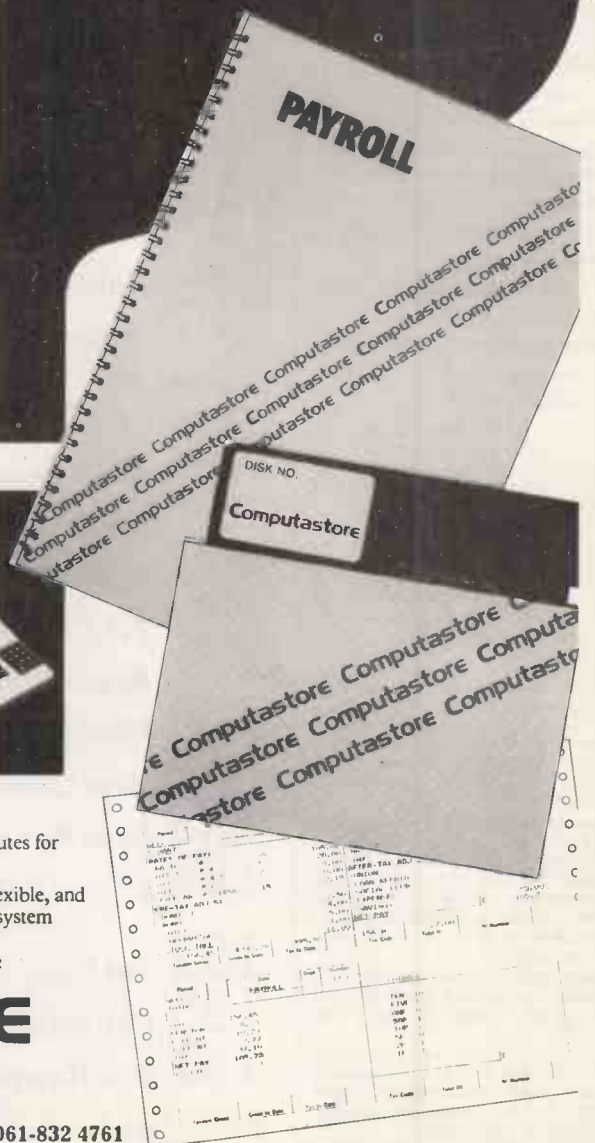
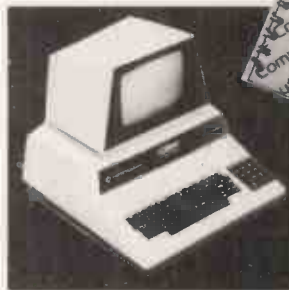

Comart Approved Dealers

Belfast
O & M Systems
95 Dublin Road
Tel: 0232 49440

Birmingham
Byteshop Computerland Ltd
94/96 Hurst St, B5 4TD
Tel: 021 622 7149

Cambridge
Cambridge Computer Stores
1 Emmanuel St, CB1 1NE
Tel: 0223 68155

Cornwall
Benchmark Computer
Systems Ltd
Tremena Manor
Tremena Road
St Austell, PL25 5GG
Tel: 0726 610000

Dublin
Lendac Data Systems Ltd
8 Dawson St
Tel: 0001 372052

Glasgow
Byteshop Computerland Ltd
Magnet House
61 Waterloo St, G2 7BP
Tel: 041 221 7409

Leeds
Holdene Ltd
Manchester Unity House
11/12 Rampart Road
Woodhouse St
Tel: 0532 459459

London
Byteshop Computerland Ltd
324 Euston Road
London W1
Tel: 01-387 0505
Digitus
9 Macklin Street
Covent Garden WC2
Tel: 01 405 6761

Jarrogate
67 Tulsemere Road,
West Norwood,
London SE17
Tel: 01-670 3674

Manchester
Byteshop Computerland Ltd
11 Gateway House
Piccadilly Station Approach
Tel: 061 236 4737

NSC Computers
29 Hanging Ditch
Tel: 061 832 2269

Newbury
Newbear Computing Store
40 Bartholomew St
Tel: 0635 30505

Nottingham
Byteshop Computerland Ltd
92A Upper Parliament St,
NG1 6LF
Tel: 0602 40576

Sheffield
Hallam Computer Systems
451 Eccleshall Road, S11 9PN
Tel: 0742 663125

Southampton
Xitan Systems
23 Cumberland Place,
SO1 2BB
Tel: 0703 38740

Sudbury
Eurotec Consultants
Holbrook Hall
Little Watlingford
Tel: 0206 262319

Warwicks
Business & Leisure
Microcomputers
16 The Square
Kenilworth
Tel: 0926 512127

Watford
Lux Computer Services
108 The Parade
High Street
Watford WD11 2AW
Tel: 0923 29513

Comart Microcomputer dealers are located strategically throughout the country to give support, guidance and assistance. In the event of difficulty contact Comart direct.



Horizon Hard Disc adds a new dimension to cost effective data processing

With its parentage already established as the proven performer in its price range, North Star's Hard Disc Horizon is set to break new barriers in cutting the cost of data storage and retrieval.

It offers 18 Megabytes of on line storage, and at current prices that works out at less than 0.03p per byte. And, with up to 10 times the speed of operation of the more conventional floppy discs, and the convenience of storing all your data on-line, it's a basic price incentive that's amplified

even more in reduced operating costs and efficiency:

Add to that the new North Star Application Software, Word Processing, Information Management and Reporting System and you'll understand why we say that North Star is set for new horizons of application.

Find out the facts about expanding your North Star Horizon today!

The U.K. Leaders in Microcomputer Development, Application and Support.

comart

St Neots HUNTINGDON Cambs PE19 2AF
Tel (0480) 215005 Telex: 32514 Comart G.

• Circle No. 103

NEW SUPERBOARD SERIES II

Ready built & Tested

New from OSI - Series II. Everything series I had but with more on a single board. Ideal for the beginner or experienced engineer alike. It needs only a 5V 3A power supply to be up and running. Fully expandable to a Floppy Disc and small business system.

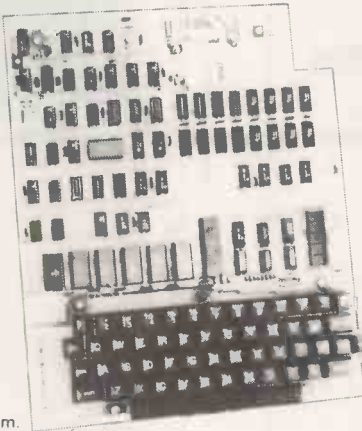

STILL ONLY £149 + P&P £3.50 + VAT

- 625 lines jitter free Display.
- Memory Mapped Video Display with upper/lower case graphics and gaming characters.
- Software selectable Display 24 x 24 48 x 12
- Uses the ultra powerful 6502 Micro.
- 8K Microsoft Basic in Rom.
- Full feature Basic runs faster than currently available computers and all 8080 based business computers.
- 4K static Ram on board expandable to 8K.
- Full 53 Keyboard with upper/lower case and user programmability.
- Power on reset standard.
- 2 second action break key.
- Kansas City standard Audio cassette interface for high reliability.

- 6 latch outputs available for control purposes.
- 8 bit Digital to Analogue converter.
- Full machine code monitor and I/O utilities in Rom.

Superboard II Series II £149.00 + VAT
 Black ABS case £ 24.50 + VAT
 Extra 4K Ram £ 14.00 + VAT
 PSU 5A Ready Built £ 23.00 + VAT
 Numeric Key Pad Kit £ 11.95 + VAT
 610 Expansion Board with 8K fitted (expandable to 24K) £150.00 + VAT
 CD3P Floppy Disc £269.00 + VAT
 WEMON £ 19.95 + VAT

Series 2 User's Manual The best single source of information £6.95, no VAT

Video swap tape & UHF modulator FREE!

SOFTY

The complete microprocessor development system for the engineer and beginner alike.

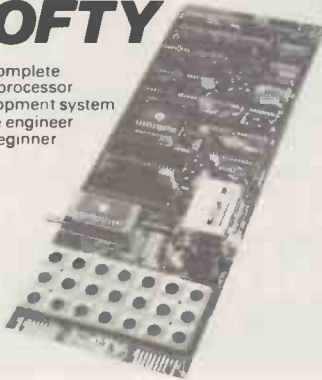

- Displays memory contents on standard UHF TV.
- Can replace monitor Rom to test and develop programs.
- Ideal training aid.
- Two 8-bit I/O ports.
- Fast cassette interface.
- On-board Eprom programmer.
- Copies software.
- Simple modification for single rail.

Price: Kit.....£ 99.00 + VAT
 Ready built.....£120.00 + VAT
 PSU.....£ 20.00 + VAT
 P & P.....£ 1.50 + VAT

FREE 2716 with each Softy

STAKPAK

Unique filing system comprising stackable drawers, each containing 2 digital quality C12 cassettes. Complete with index cards & blank labels



5 Stakpaks (10 cassettes)
£5-25 P&P 75p + VAT

VIDEO GENIE

A complete Computer System

- 16K User Ram
- 12K Microsoft Basic in Rom.
- 64 x 16 line Display
- 128 x 48 dot graphics resolution.
- Software compatible with TRS80 level II.
- Built in Cassette Recorder.
- Output and Control for Second Cassette.
- Full expansion via Expansion box to Disc-Printer



£289

P & P £5 + VAT

A Z80 based computer system with Full Keyboard and built in Cassette recorder plus outputs for Monitor and/or TV Parallel Printer Interface £35 + VAT

SEIKOSHA GP80A

This Unihammer dot Matrix Printer gives Normal and Double Width Characters as well as Dot resolution Graphics.



- Printing Speed 30 cps
- Character Set 5 x 7 Matrix
- Print Density 12 CPI at 80 CPL
- Paper Feed 8" Tractor
- Parallel Interface Standard

Other Interfaces
 RS 232 £49 + VAT
 IEEE 488 or Apple £35 + VAT
 Pet £35 + VAT

£225
 P & P £4.50 + VAT

500 Sheets of paper FREE!

EPSON TX80

A complete 80 column dot matrix printer, available in tractor or friction feed versions.

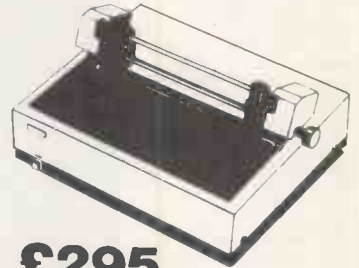

- Speed: 125cps.
- Unidirectional print
- PET compatible graphics.

£295

P & P £4.50 + VAT

Various Interfaces available from £35.00

500 Sheets of paper FREE!

SUPERPRINT 800



This rugged and reliable printer offers more features and flexibility than competitive units but at a new Special Offer price

- 64, 72, 80, 96, 120, or 132 characters/line.
- RS-232, 20ma, 1EEE-488 and Centronics
- Self-test switch.
- I/O fitted as standard.
- 16 baud rates to 19,200.
- Tractor and Friction Feed
- 60 lines per minute.
- Multiple character sets facility.

£299

P & P £4.50 + VAT

500 Sheets of paper FREE!

ACCESSORIES

TEX Eprom Eraser	£33
6Mhz Modulators	£2.80
8Mhz Modulators	£4.50
Cassette Recorders	£13.95
8" Fan-Fold Paper 500 sheets	£5.95
9 1/2" Fan-Fold Paper 500 sheets	£5.95
TELEPRINTER ROLL	£3.00
9" B & W Monitor	£65.00
HEX PAD	£3.50
ASCII Keyboard 756	£40
CEGMON any version	£29.50
Space Invaders 8K	£4.60
BASF Floppy Discs - each	£2.85

ALL PRICES EXCLUSIVE OF VAT & CARRIAGE



WATFORD ELECTRONICS

TTL 74 (TEXAS) Series	74123 65 74125 50 74126 45 74128 45 74132 55 74136 55 74141 75 74142 185 74143 250 74144 250 74145 90 74147 150 74150 130 74151 70 74153 70 74154 120 74155 75 74156 75 74157 70 74159 165 74160 96 74161 99 74162 99 74163 99 74164 120 74165 129 74166 130 74167 205 74170 205 74172 375 74173 150 74174 100 74175 82 74176 80 74177 85 74178 110 74179 150 74180 90 74181 280 74182 85 74184 130 74185 130 74188 310 74190 130 74191 120 74192 120 74193 120 74194 102 74195 75 74196 99 74197 88 74198 160 74199 160 7421 120 7422 75 7423 90 7424 99 7425 105 7426 33 7427 110 7428 66 7429 84 7430 84 7431 84 7432 84 7433 84 7434 84 7435 84 7436 84 7437 84 7438 84 7439 84 7440 84 7441 84 7442 84 7443 84 7444 84 7445 84 7446 84 7447 84 7448 84 7449 84 7450 84 7451 20 7452 20 7453 20 7454 20 7455 20 7456 20 7457 20 7458 20 7459 20 7460 20 7461 20 7462 20 7463 20 7464 20 7465 20 7466 20 7467 20 7468 20 7469 20 7470 20 7471 20 7472 20 7473 20 7474 20 7475 20 7476 20 7477 20 7478 20 7479 20 7480 20 7481 20 7482 20 7483 20 7484 20 7485 20 7486 20 7487 20 7488 20 7489 20 7490 20 7491 20 7492 20 7493 20 7494 20 7495 20 7496 20 7497 20 7498 20 7499 20 7500 20	LS02 15 LS03 15 LS04 15 LS05 23 LS08 22 LS09 23 LS10 20 LS11 32 LS12 32 LS13 40 LS14 60 LS15 40 LS20 21 LS21 32 LS22 35 LS26 44 LS27 35 LS28 35 LS30 20 LS32 25 LS33 35 LS37 30 LS38 35 LS40 28 LS42 66 LS47 85 LS48 105 LS49 105 LS51 25 LS54 30 LS55 30 LS71 150 LS73 45 LS74 35 LS75 45 LS76 45 LS78 50 LS83 105 LS85 80 LS86 38 LS89 50 LS91 125 LS92 75 LS93 60 LS95 115 LS97 120 LS107 45 LS109 75 LS112 40 LS113 75 LS114 40 LS122 70 LS123 75 LS124 180 LS125 45 LS126 45 LS132 60 LS133 35 LS136 55 LS138 70 LS139 70 LS145 210 LS147 120 LS148 170 LS151 90 LS153 85 LS155 75 LS156 85 LS157 70 LS158 70 LS160 90 LS161 98 LS162 110 LS163 95 LS164 115 LS165 145 LS166 175 LS168 210 LS169 210 LS170 288 LS173 105 LS174 110	LS175 110 LS181 295 LS182 295 LS188 128 LS190 95 LS191 95 LS192 95 LS193 95 LS194 125 LS195 130 LS196 120 LS197 85 LS200 345 LS221 120 LS240 165 LS241 165 LS242 165 LS243 165 LS244 195 LS245 350 LS247 135 LS248 135 LS249 135 LS251 130 LS253 95 LS257 95 LS258 120 LS259 160 LS261 450 LS266 75 LS267 165 LS275 320 LS279 88 LS280 250 LS283 90 LS290 130 LS293 130 LS295 215 LS298 215 LS299 420 LS300 175 LS302 175 LS323 270 LS324 200 LS325 320 LS326 330 LS327 315 LS346 185 LS347 150 LS348 190 LS352 185 LS353 185 LS365 65 LS366 65 LS367 65 LS368 90 LS373 150 LS374 150 LS375 150 LS377 195 LS378 140 LS379 215 LS384 250 LS385 420 LS386 85 LS390 140 LS393 140 LS395 210 LS396 199 LS398 275 LS399 230 LS445 140 LS447 195 LS490 245 LS668 105 LS669 105 LS670 270 LS673 750 LS674 850	74S04 73 74S132 138 74S138 240 74S158 240 74S188 210 74S189 158 74S194 360 74S241 540 74S262 850 74S287 325 74S470 325 74S472 1150 74S475 825	75 Series 75150 140 75154 150 75450 95 75451 70 75452 225 75454 89	COMPUTER IC's 2114L-300n 175 2114L-200n 225 2532-32K £10 2708 350 2732-450n £10 2716-5V 450 4116 199 6802 675 6820 325 6822 570 6832 795 6845 1450 6851 795 6852 2572 6800 490 6802 595 6810 280 6821 315 6840 750 6850 315 6852 390 8080A 450 8085A 1190 81LS95 125 81LS96 125 81LS97 125 8212 210 8214 425 8216 200 8251 475 8253 999 8609 1550 8726A 195 8728A 195 8795N 160 8797N 150 AY-3-1015 420 AY-1013 265 AY-5-2376 750 MC1488 90 MC1489 90 MC14411 950 MC14412 1250 MK4027-2 450 RO-3-2513U 600 RO-3-2513J 600 SF86364E 950 SFC71301 820 TMS2716-3V 1050 TMS4027 325 TMS6011 365 Z80CPU 25 650 Z80ACPU4M 825 Z80 P10 440 Z80A P10 575 Z80 CTC 440 Z80A CTC 675 Z80 DART £12 Z80A DART £15
------------------------------	---	--	--	---	--	---

W@MON

The Definitive Monitor

A 4k monitor specially designed to produce the best from your Superboard, Superboard Series 2, UK101 or Enhanced System.

Look at these superb facilities:

- Full screen editing.
- Home cursor/screen clear facility.
- True insert/delete.
- Fully programmable cursor control with meaningful symbols on screen.
- Single key Basic
- True ASCII keyboard routine.
- Auto remote control of tape recorder (requires only a relay).
- Open line facility.
- Named tape files.
- Two key video swap (Series 2 only).
- Bell (Series 2 only).
- Cursor indication of quotes mode.
- User definable flashing cursor character.
- User controllable command vectoring for your own machine code routines.
- Full or partial scroll-up or scroll-down (callable by program).
- Auto list on error (displays faulty line upon carriage return).
- Single command save (automatically returns "list").
- Centronics compatible printer driver.

Monitor functions include:

- Scrolling list in data mode.
- Warm restart vector.
- Fill memory.
- Search memory.
- Two save and three load routines.
- Floppy disc vector.
- Break handling routine.
- Tabular display of memory.

CRYSTALS	'D' CONNECTORS (Cannon type)	DIL PLUGS (Headers)	DIL switches
100KHz 300 455KHz 370 1MHz 295 1.008M 295 1.8432M 300 2.0MHz 305 2.4576M 305 3.2768M 150 3.57954M 150 4.0MHz 290 4.032M 290 4.194304M 270 4.433619M 150 5.0MHz 290 5.185M 300 5.24288M 390 6.0MHz 290 6.144M 295 6.5536M 290 7.168M 290 7.68MHz 300 8.0MHz 290 8.867237 270 10.0MHz 290 10.7MHz 270 12.0MHz 290 14.31818M 320 16.0MHz 290 18.0MHz 290 18.432M 290 26.69M 290 27.648M 330 38.6667 290 48.0MHz 270 100.0MHz 375	Plugs Sockets Covers plastic 9 way 90p 118p — 15 way 120p 167p 150p 25 way 180p 230p 170p 37 way 268p 390p 185p	14 pin 44p 16 pin 49p 24 pin 88p 40 pin 295p	4 way 10 way 85p 175p 6 way 98p SPDT 8 way 4 way 115p 190p
	DIL SOCKETS (TEXAS)	JUMPER LEADS (Ribbon Cable Assemblies)	
	Low profile Wire wrap 8 pin 10p 25p 14 pin 10p 35p 16 pin 10p 46p 18 pin 16p 52p 20 pin 22p 65p 22 pin 25p 70p 24 pin 30p 78p 28 pin 35p 85p 36 pin — 105p 40 pin 40p 109p	Single end DIP Jumpers length 24" 14 pin 145p 16 pin 165p 24 pin 240p 40 pin 385p	
	EDGE CONNECTORS (TEXAS) double type	SPECIAL OFFER	
	1 156 2 x 10 way — 82p 2 x 15 way — 98p 2 x 18 way 140p 120p 2 x 22 way 150p 125p 2 x 25 way 165p 160p 2 x 30 way 188p — 2 x 36 way 197p — 2 x 40 way 205p — 2 x 43 way 250p —	2114L-300n 175p 2114L-200n 225p 2532-32k £10 2732-450n £10 2708 350p 2716-5v 450p 4116-16k 199p	

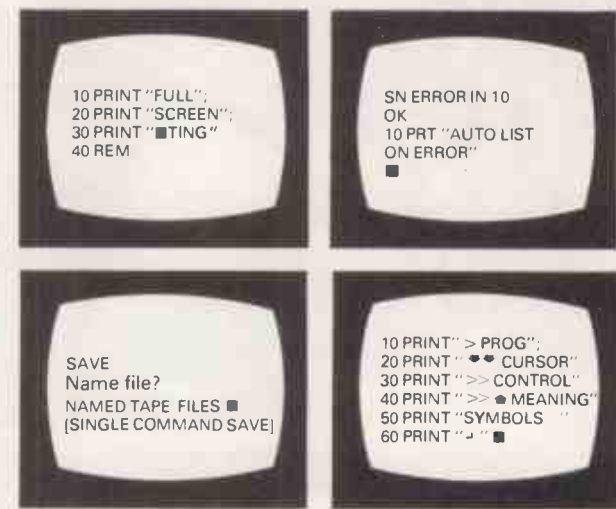

All this for only £19.95

+ 50p P&P + VAT.

To order: Send £23.52 or phone your ACCESS number for same day despatch. State version required.

The above is just a selection of our vast stocks of brand new, full spec, electronic components. To Order: Please add 15% VAT to all orders unless stated. On orders of less than £10 add 40p P&P. Terms of Business: Cash/Cheque/P.O.'s or Bankers Draft with order. Access Orders: Minimum £10 please.



Government, Education Authorities & Trade Welcome. JUST PHONE IN YOUR ORDER WE DO THE REST.

33/35 CARDIFF ROAD, WATFORD, HERTS. Telephone 40588



The Commodore PET offers you a safe passage through the primeval swamp of computerisation.

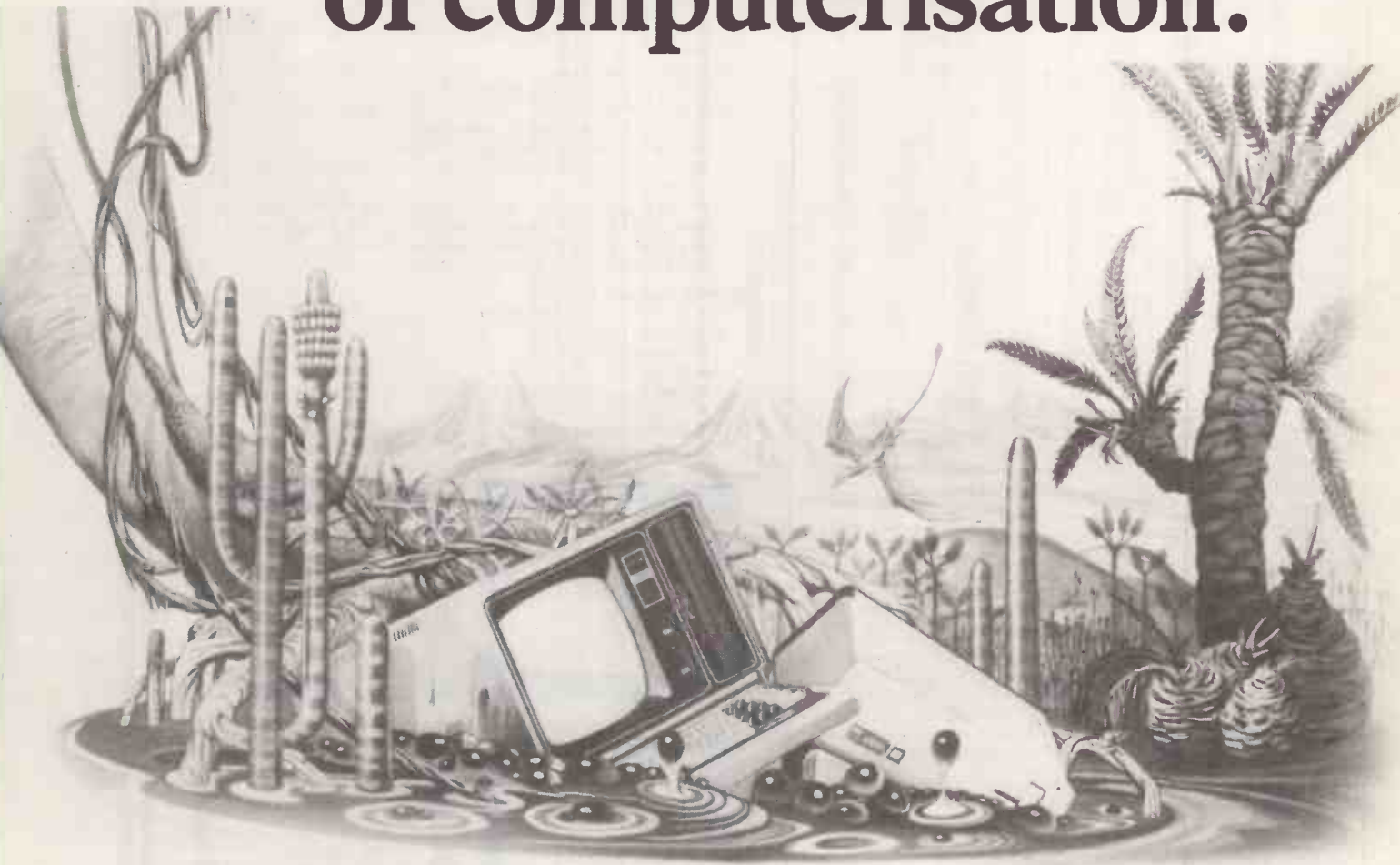

The miracle of microchip technology has made the main-frame computer seem like a dinosaur. But how many microcomputers will go the same way?

Without good software and support a micro-computer is less capable than your office calculator. So as competition grows amongst manufacturers in this industry, only those with the finest software and the best supporting facilities will survive.

SHARE A SECURE FUTURE WITH A COMMODORE PET

We at Commodore have been producing high technology

products for over 20 years. And unlike most other manufacturers of micro-computers, we make everything ourselves (including the silicon chips) to keep our costs to a minimum.

These cost savings are passed on to you in excellent value for money. So you can now buy a self-contained Commodore PET microcomputer for £450, or a complete business system (including Floppy Disk Unit and High Speed Printer) starting from as little as £2000.*

However, computer hardware can only be as good as the software available. That's why, to maintain our position as

Britain's most popular microcomputer, we have made sure that the quality and versatility of our software is second to none.

LARGEST, FINEST CHOICE OF SOFTWARE...

To complement our microcomputers, we have the finest and most comprehensive range of programs available in the U.K. today. This covers everything from such important business applications as Payroll, Stock Control, Accounting, Filing, Mailing; to our series in the field of Education. Each program is thoroughly tried, tested and tailored to BRITISH needs. You won't catch us palming you off with an irrelevant American version!

...AT SURPRISINGLY LOW PRICES

With over 30,000 Commodore PETs employed in Britain, the demand for programs is tremendous. And through mass-production we are able to keep our costs to you surprisingly low. So you can buy a Petpack program (on cassette) for between £5 and £50, while business programs (on disk) range from between £50 and £500.

OUR OWN UNIQUE TRAINING COURSES

Commodore programs are designed with operational simplicity in mind. Commands are in plain English and guidance is built into each package. So that even a stranger to computers can quickly feel at home with a PET.

Nevertheless, to maximise the potential of your Commodore system, you will find a certain amount of training of immense value. Of the well-known names in microcomputers, Commodore is the only one to offer a

range of training courses and seminars. And these have already proved of great benefit to thousands of PET users.

KEEP IN TOUCH WITH THE PET USERS' NEWSLETTER

Another unique way in which Commodore helps you get the most out of your microcomputer is by publishing the regular PET Users' Newsletter. For an annual subscription of only £10 you can keep up-to-date with developments and share new ideas and applications with over 3,000 PET users.

WORDPROCESSOR AS WELL AS COMPUTER

In addition to Commodore's own high quality range of hardware and software, there are compatible products of other manufacturers which have gained our official stamp of approval.

Look out for this sign.  You'll find it on such famous programs as WORDPRO and WORDCRAFT, which turn your PET into a first-class wordprocessor; as well as on hardware like the MUPET system, which allows a number of PETs to be run with a single, letter-quality printer.

PROFESSIONAL DEALER SUPPORT COUNTRYWIDE

When you consult a Commodore dealer, you won't find yourself talking to a typewriter salesman. Our dealers are qualified to examine your needs, and to demonstrate which hardware and software will suit you best. Trained engineers are at hand and a 24-hour field maintenance service is available countrywide.

LONDON AREA

Adda Computers Ltd,
W13, 01-579 5845
Advanced Management Systems,
EC2, 01-638 9319
C.S.S. (Business Equipment)
Ltd, E8, 01-254 9293
Centralex - London Ltd,
SE13, 01-318 4213
Computer Sales & Software
Centre Ltd,
ILFORD, 01-554 3344
Cream Computer Shop,
HARROW, 01-863 0833
Da Vinci Computer Shop,
EDGWARE, 01-952 0526
Henderson Bennett,
SE25, 01-654 5609
Home and Business Computers,
E12, 01-472 5107
L & J Computers,
NW9, 01-204 7525
Logic Box Ltd,
SW1, 01-222 1122
Merchant Systems Ltd,
EC4, 01-353 1464
Micro Computer Centre,
HAMPTON HILL, 01-979 4546
Sumlock Bondain Ltd,
EC1, 01-250 0505
Sumlock Bondain Ltd,
EC4, 01-626 0487

HOME COUNTIES

Millhouse Designs Ltd,
ALTON, 84517
H.S.V. Ltd,
BASINGSTOKE, 62444
MMS Ltd,
BEDFORD, 40601
D.D.M. Direct Data Marketing
Ltd, BRENTWOOD, 214168

Amplicon Micro Systems Ltd,
BRIGHTON, 562163
T & V Johnson (Microcomputers
Etc) Ltd, CAMBERLEY, 20446
Cambridge Computer Store,
CAMBRIDGE, 65334
Wego Computers Ltd,
CATERHAM, 49235
Dataview Ltd,
COLCHESTER, 78811
Amplicon Micro Systems Ltd,
CRAWLEY, 26493
S.M.G. Microcomputers,
GRAVESEND, 55813
South East Computers,
HASTINGS, 426844
Bromwall Data Services Ltd,
HATFIELD, 60980
Alpha Business Systems,
HERTFORD, 57425

Commonsense Business Systems
Ltd, HIGH WYCOMBE, 40116
Kingsley Computers Ltd,
HIGH WYCOMBE, 27342
Brent Computer Systems,
KINGS LANGLEY, 65056
Computopia Ltd,
LEIGHTON BUZZARD, 376600
South East Computers Ltd,
MAIDSTONE, 681263
J.R. Ward Computers Ltd,
MILTON KEYNES, 562850
Sumlock Bondain (East Anglia)
Ltd, NORWICH, 26259
T & V Johnson (Microcomputers
Etc) Ltd, OXFORD, 721461
C.S.E. (Computers),
READING, 61492
Slough Microshop,
SLOUGH, 72470
Business Electronics,
SOUTHAMPTON, 738248
H.S.V. Ltd,
SOUTHAMPTON, 22131
Super-Vision,
SOUTHAMPTON, 774023

Symtec Systems Ltd,
SOUTHAMPTON, 38868
Stuart R Dean Ltd,
SOUTHEND-ON-SEA, 62707
The Computer Room,
TUNBRIDGE WELLS, 41644
Orchard Computer Services,
WALLINGFORD, 35529
Photo Acoustics Ltd,
WATFORD, 40698
Microchips,
WINCHESTER 68085
P.P.M. Ltd,
WOKING, 80111
Petalect Electronic Services
Ltd, WOKING, 69032
Oxford Computer Systems,
WOODSTOCK, 812838

MIDLANDS &

S. HUMBERSIDE
C.B.S. Consultants,
BIRMINGHAM, 772 8181
Computer Services Midlands
Ltd, BIRMINGHAM, 382 4171
Marchant Business Systems Ltd,
BIRMINGHAM, 706 8232
Micro Associates,
BIRMINGHAM, 328 4574
Peach Data Services Ltd,
BURTON-ON-TRENT, 44968
Jondane Associates Ltd,
COVENTRY, 664400
Davidson-Richards Ltd,
DERBY, 366803
Allen Computers,
GRIMSBY, 40568
Caddis Computer Systems Ltd,
HINCKLEY, 613544
Machsize Ltd,
LEAMINGTON SPA, 312542
Arden Data Processing,
LEICESTER, 22255

Roger Clark Business Systems
Ltd, LEICESTER, 20455
Lowe Electronics,
MATLOCK, 2817
A.J.R. Office Equipment Services
Ltd, NOTTINGHAM, 206647
Betos (Systems) Ltd,
NOTTINGHAM, 48108
PEG Associates (Computer
Systems Ltd), RUGBY, 65756
Walters Computer Systems Ltd,
STOURBRIDGE, 70811
System Micros Ltd,
TELFORD, 460214

YORK & N. HUMBERSIDE

Ackroyd Typewriter & Adding
Machine Co. Ltd,
BRADFORD, 31835
Microprocessor Services,
HULL, 23146
Holdene Ltd,
LEEDS, 459459
South Midlands Communications
Ltd, LEEDS, 782326
Yorkshire Electronics Services
Ltd, MORLEY, 522181
Computer Centre (Sheffield) Ltd,
SHEFFIELD, 53519
Hallam Computer Systems,
SHEFFIELD, 663125
Holbrook Business Systems Ltd,
SHEFFIELD, 484466

NORTH EAST

Currie & Maughan,
GATESHEAD, 774540
Elfton Ltd,
HARTLEPOOL, 61770
Dyson Instruments,
HETTON, 260452
Fiddes Marketing Ltd,
NEWCASTLE, 815157

Format Micro Centre,
NEWCASTLE 21093
Intex Datalog Ltd,
STOCKTON-ON-TEES, 781193

S. WALES & WEST COUNTRY

Radan Computational Systems,
BATH, 318483
C.S.S. (Bristol) Ltd,
BRISTOL, 779452
T & V Johnson (Microcomputers
Etc) Ltd,
BRISTOL, 422061
Sumlock Tabdown Ltd,
BRISTOL, 276685
Sigma Systems Ltd,
CARDIFF, 34869
Reeves Computers Ltd,
CARMARTHEN, 32441
A.C. Systems,
EXETER, 71718
Milequip Ltd,
GLOUCESTER, 411010
Jeffrey Martin Computer Services
Ltd, NEWQUAY, 2863
Devon Computers,
PAIGNTON, 526303
A.C. Systems,
PLYMOUTH, 260861
J.A.D. Integrated Services,
PLYMOUTH, 62616
Business Electronics,
SOUTHAMPTON, 738248
Computer Supplies (Swansea),
SWANSEA, 290047

NORTH WEST & N. WALES

B & B (Computers) Ltd,
BOLTON, 26644
Tharstern Ltd,
BURNLEY, 38481

Megapalm Ltd,
CARNFORTH, 3801
Catlands Information Systems
Ltd, CHESTER, 46327
Catlands Information Systems
Ltd, WILMSLOW, 527166

LIVERPOOL

Aughton Microsystems Ltd,
LIVERPOOL, 548 7788
Stack Computer Services Ltd,
LIVERPOOL, 933 5511

MANCHESTER AREA

Byte Shop Computerland,
MANCHESTER, 236 4737
Computastore Limited,
MANCHESTER, 832 4761
Cytek (UK) Ltd,
MANCHESTER, 872 4682
Executive Reprographic Ltd,
MANCHESTER, 228 1637
Professional Computer Services
Ltd, OLDHAM, 061-624 4065

SCOTLAND

Gate Microsystems Ltd,
DUNDEE, 28194
Holdene Microsystems Ltd,
EDINBURGH, 668 2727
Gate Microsystems Ltd,
GLASGOW, 221 9372
Robox Ltd,
GLASGOW, 8413
Thistle Computers (Macmicro),
INVERNESS, 712774
Ayrshire Office Computers,
KILMARNOCK, 42972
Thistle Computers,
KIRKWALL, 3140

N. IRELAND

N. Ireland Computer Centre,
HOLLYWOOD, 6548

This list covers dealers participating in our advertising. *Prices quoted ex. VAT.

For your free literature pack send off the coupon to the address below.

Name _____ Position _____

Address _____

Intended application _____

commodore

Commodore Information Services, 818 Leigh Road, Slough, Berks. SL1 4BD

• Circle No. 105

08PR1

9

Mail Order Software

from the world's leading microsoftware supplier

Software for most popular 8080/Z80 computer disk systems including

NORTH STAR HORIZON, VECTOR MZ, OHIO SCIENTIFIC, SUPERBRAIN, Z80 APPLE, CROMEMCO, RAIR BLACK BOX, DYNABYTE, SD SYSTEMS, RESEARCH MACHINES, EXIDY SORCERER, IMSAI, HEATH, and 8" IBM formats

Software with Manual / Manual Alone

Software with Manual / Manual Alone

Software with Manual / Manual Alone

DIGITAL RESEARCH

- CP/M* FOOS — Diskette Operating System complete with Text Editor, Assembler, Debugger, File Manager and system utilities. Available for wide variety of disk system including North Star, Helios II, Micropolis, ICOM (all systems) and Altair. Supports computers such as Sorcerer, Horizon, Cromemco, Ohio Scientific, RAIR Black Box, Research Machines, Dynabyte, etc. from £75/£15
- CP/M version 2 (not all formats available immediately) £95/£15
- CP/M for Apple 11* Softcard **NEW Z80 Microsoft BASIC - 80** with high resolution graphics £250/£15
- MP/M £195/£25
- MAC — 8080 Macro Assembler. Full Intel macro definitions. Pseudo Ops include RPC, IRP, REPT, TITLE, PAGE, and MACLIB. Z-80 library included. Produces Intel absolute hex output plus symbols file for use by SID (see below) £55/£10
- SID — 8080 symbolic debugger. Full trace, pass count and break-point program testing system with back-trace and histogram utilities. When used with MAC, provides full symbolic display of memory labels and equated values £45/£10
- ZSID Includes Z80 mnemonics, requires Z80 CPU £50/£10
- TEX — Text formatter to create paginated, page-numbered and justified copy from source text files, directable to disk or printer £45/£10
- DESPOOL — Program to permit simultaneous printing of data from disk while user executes another program from the console £30/£1

MICROSOFT

- BASIC-80 — Disk Extended BASIC Interpreter Version 5, ANSI compatible with long variable names, WHILE/WEND, chaining, variable length file records. £155/£15
- BASIC Compiler — Language compatible with Version 5 Microsoft Interpreter and 3-10 times faster execution. Produces standard Microsoft relocatable binary output. Includes Macro-80. Also linkable to FORTRAN-80 or COBOL-80 code modules £195/£15
- FORTRAN-80 — ANSI '66 (except for COMPLEX) plus many extensions. Includes relocatable object compiler, linking loader, library with manager. Also includes MACRO-80 (see below) £205/£15
- COBOL-80 — ANSI '74 Relocatable object output. Format same as FORTRAN-80 and MACRO-80 modules. Complete ISAM. Interactive ACCEPT DISPLAY, COPY, EXTEND £325/£15
- MACRO-80 — 8080/Z80 Macro Assembler. Intel and Zilog mnemonics supported. Relocatable linkable output. Loader, Library Manager and Cross Reference List utilities included £75/£10

- XMACRO-86 — 8086 cross assembler. All Macro and utility features of MACRO-80 package. Mnemonics slightly modified from Intel ASM86. Compatibility data sheet available £155/£15
- EDIT-80 — Very fast random access text editor for text with or without line numbers. Global and intra-line commands supported. File compare utility included £45/£10

EIOS SYSTEMS

- KBASIC — Microsoft Disk Extended BASIC version 4.51 integrated with KISS Multi-Keyed Index Sequential and Direct Access file management as 9 additional BASIC commands. KISS included as relocatable modules linkable to FORTRAN-80, COBOL-80, and BASIC COMPILER. Specify CP/M version 1.4 or 2.x when ordering. Requires 48K CP/M £295/£25 To licensed users of Microsoft BASIC-80 (MBASIC) £215/£25

MICROPRO

- SUPER-SORT 1 — Sort, merge, extract utility as absolute executable program or linkable module in Microsoft format. Sorts fixed or variable records with data in binary, BCD, Packed Decimal, EBCDIC, ASCII, floating, fixed point, exponential, field justified, etc. etc. Even variable number of fields per record! £125/£15
- SUPER-SORT II — Above available as absolute program only £105/£15
- SUPER-SORT III — As II without SELECT/EXCLUDE £75/£15
- WORD-MASTER Text Editor — In one mode has super-set of CP/M's ED commands including global searching and replacing, forward and backwards In file. In video-mode, provides full screen editor for users with serial addressable-cursor terminal £75/£15
- WORD-STAR — Menu driven visual word processing system for use with standard terminals. Text formatting performed on screen. Facilities for text paginate, page number, justify, center, underscore and PRINT. Edit facilities include global search and replace, read/write to other text files, block move, etc. Requires CRT terminal with addressable cursor positioning £255/£15
- WORD-STAR/MAIL-MERGE — As above with option for production mailing of personalised documents with mail list from Datatar or NAD £315/£15
- DATASTAR — Professional forms control entry and display system for key-to-disk data capture. Menu driven with built-in learning aids. Input field verification by length, mask, attribute (i.e. uppercase, lowercase, numeric, auto dup., etc.). Built-in arithmetic capabilities using keyed data, constants and derived values. Visual feedback for ease of forms design. Files compatible with all CP/M-MP/M supported languages. Requires 32K CP/M £195/£25

GRAFFCOM

- PAYROLL — Designed in conjunction with the spec for PAYE routines by HMI Taxes. Processes up to 250 employees on weekly or monthly basis. Can handle cash, cheque or bank transfer payments plus total tracking of all year to date figures. Prints emp master, payroll log, payslips and bank giro. Requires CBASIC-2 £475/£35
- COMPANY SALES — Performs sales accounting function. Controls payments of invoices and prints sales ledger and aged debtors report. Suitable for any accounting period. Comprehensive VAT control and analysis of all sales invoices. Requires CBASIC-2 £425/£35
- COMPANY PURCHASES — Performs purchase accounting function. Controls invoices, credit & debit notes. Prints purchase ledger, aged creditors report and payment advices. Comprehensive VAT control and analysis of all purchases. Interfaces with the ADD system. Requires CBASIC-2 £425/£35
- GENERAL ACCOUNTING — Produces Nominal Ledger, Trial Balance, P/L and Balance Sheet. Define your own coding system. Interactive data entry plus optional data capture from Company Sales and Company Purchases. Requires CBASIC-2 £375/£35
- STOCK CONTROL — Maintains stock records, monitors stock levels to ensure optimum stock holding. Details include stock desc., product code, unit, unit price, quantity on hand on order/minimum. Stock analysis reports can be weekly, monthly, quarterly etc. Interfaces with Order Entry Invoicing system. Requires CBASIC-2 £325/£35
- ORDER ENTRY & INVOICING — Performs order entry and invoicing function. Handles invoices for services and consumable items, part orders and part quantities. Sales Analysis report shows sales movements and trends for user-defined period. Interfaces with Stock Control, ADD and Company Sales systems. Requires CBASIC-2 £325/£35
- ADD — Complete control of all your names & addresses including suppliers, clients, enquiries etc. Assign your own coding system and select all output via the report generator. Will print anything from mailing labels to directories. Requires CBASIC-2 £225/£35
- TIME RECORDING SYSTEM — Provides comprehensive control over manhour expenditures by job or account. Expense details can also be controlled. Up to 75 activities can be assigned and reports produced weekly/monthly showing movements and job account totals to date. Requires CBASIC-2 £375/£35
- LEASE RENTAL & HP SYSTEM — Designed to control agreements and contracts that are payable at regular intervals by fixed amounts. Handles lease, rental, HP or maintenance agreements with payments by invoice, SO, or cash. Can be used with ADD and CSS for complete credit control system. Requires CBASIC-2 £375/£35

Also available in bundles, contact us for details.

**Would you
interview only
one applicant
for an
important
job?**



CURRY'S MICRO SYSTEMS LTD., A MEMBER OF THE CURRY'S GROUP OF COMPANIES
OUR TERMS AND CONDITIONS OF SALE ARE DIFFERENT FROM THOSE SET OUT IN CURRY'S LTD., STATEMENT OF TRADING STANDARDS BUT THEY EMBODY THE SAME PRINCIPLE.
MORE PROTECTION FOR YOU, OUR CUSTOMER, YOU WILL FIND FULL DETAILS OF TERMS OF BUSINESS ON THE REVERSE SIDE OF OUR INVOICES AND AGREEMENTS.

If you were filling an important job, no doubt you'd make a short list.

Yet, surprisingly, many businessmen will sign on the dotted line for a micro-computer after interviewing only one.

At Micro-C, we've put together a short list for you. Although each is different, they're all value for money. (Since we're part of Currys, that's not a promise we make lightly.)

Here are four brief C.V's:

Commodore Pet

For small businesses, it'll tackle book-keeping, word processing and incomplete records.

ITT 20 20 and Apple II

If your business is slightly more involved, we might talk about the ITT 20 20 or the Apple II. They'll tackle book-keeping, incomplete records, word processing and, through Visicalc, financial planning.

National Panasonic - JD800, JD840 and Micro-C 2000.

For small businesses that want to be big businesses, we'll suggest you look at our more sophisticated hardware. They'll do all the others do but they'll also give you all the financial and management information you need to grow.

However, before we talk about hardware or software, we'll talk about your business. (It's the only way we know to give honest, unbiased advice.)

To Currys Micro-Systems Limited, 653 London Road,
High Wycombe, Bucks HP11 1EZ
 Please send me an information pack on your service and products
 Please telephone to make an appointment

Name _____
Company _____
Address _____
Telephone _____ PC3



COMPUTERS EXPLAINED BY HUMAN BEINGS.

At the same time, we'll offer any number of ways to buy or lease starting from £35 a week.

We'll also offer a one year guarantee while others are talking about 90 days.

At a little extra cost, we'll offer to service machines within one working day; and we'll help with staff training.

As for software, we test every package and if they fail to come up to our standards, we won't stock them.

Come and see us for a free demonstration. Or, if you prefer it, an interview with a very hot short list.

Nor would we.

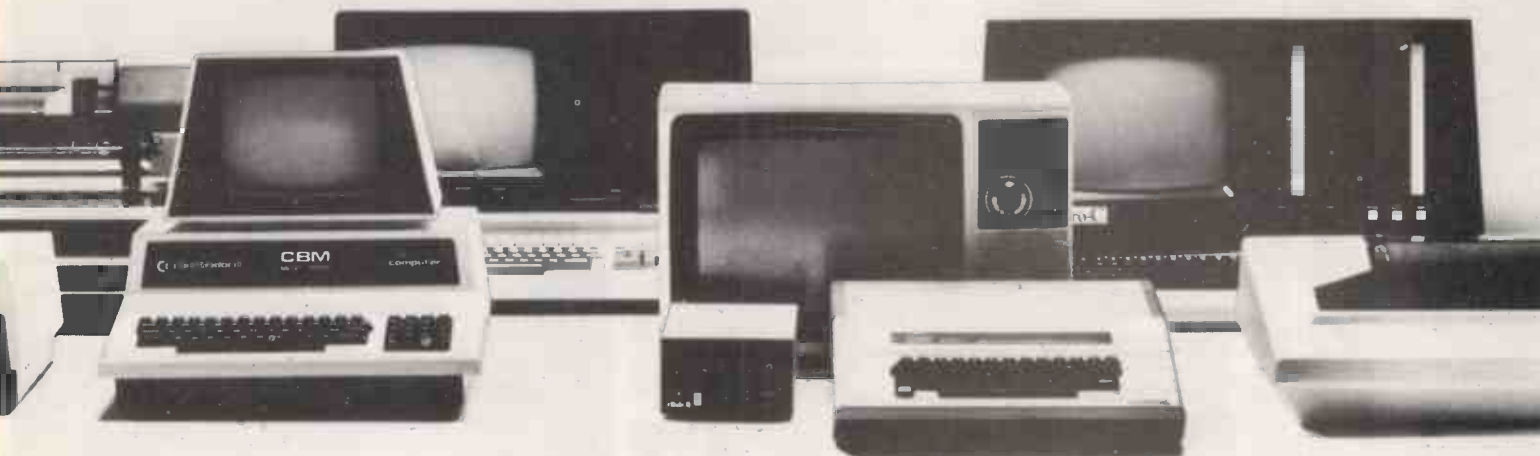

MICRO-C INSIDE CURRYS SHOPS AT: BIRMINGHAM TEL: 2331105 EXETER TEL: 213391 LEEDS ALBION STREET TEL: 446601 LUTON TEL: 0494 40262
NOTTINGHAM TEL: 412455 SOUTHAMPTON BARGATE TEL: 29676 INSIDE BRIDGERS SHOWROOMS AT: BRISTOL TEL: 650501 NEW MALDEN TEL: 01-949 2091

• Circle No. 107

EUROPE'S LARGEST SELECTION OF MICROCOMPUTER SOFTWARE, BOOKS AND MAGAZINES FOR THE HOBBYIST, EDUCATIONALIST, PROFESSIONAL AND RETAILER

BOOKS

BY OSBORNE

Introduction to Microcomputer Series	
Vol 0: Beginners Book	£5.95
Vol 1: BASIC Concepts	£8.95
Vol 2: Some Real Microprocessors (without binder)	£18.95
Vol 2: Some Real Microprocessors (with binder)	£20.50
Vol 2: Updating supplement set Nos. 1-6	£18.95
Vol 3: Some Real Support Devices (without binder)	£11.95
Vol 3: Some Real Support Devices (with binder)	£13.50
Vol 3: Updating supplement set Nos. 1-6	£18.95
1 Binder (Specify for Vol 2 or 3)	£5.75
1 Updating supplement (Specify for Vol 2 or 3)	£4.00
PET and the IEEE 488 (GPIB) Bus	£9.95
6800 Programming for Logic Design	£6.30
8080 Programming for Logic Design	£6.30
Z80 Programming for Logic Design	£6.30
Z80 Assembly Language Programming	£10.75
6502 Assembly Language Programming	£10.75
8080A/8085 Assembly Language Programming	£7.95
6800 Assembly Language Programming	£7.95
Accounts Payable and Accounts Receivable (C BASIC or Wang)	£13.15
Payroll with Cost Accounting (C BASIC or Wang BASIC)	£13.50
General Ledger (C BASIC or Wang BASIC)	£12.25
Some Common BASIC Programs	£8.95
Practical BASIC Programs	£9.25
Running Wild	£2.00
8089 I/O Processor Handbook	£4.00
Z8000 Assembly Language Programming	£13.50
The CRT Controller Handbook	£4.50
The 68000 Microprocessor Handbook	£13.50
Apple User's Guide	£13.95
CP/M User's Guide	£13.95
The 68000 Handbook	£13.95
16 Bit Microprocessor Handbook	£13.95
6809 Assembly Language Programming	£13.95

GENERAL

See Magazines and Subscriptions!	See Osborne Books!	£7.00
Microprocessors from Chips to Systems		£9.95
Microprocessor Interfacing Techniques		£8.95
IC OP-AMP Cookbook		£4.25
RTL Cookbook		£5.50
Ciarcias Circuit Cellar		£2.40
Buyers Guide to Microsoftware		£4.95
Calculating with BASIC		£3.95
Computer Programs that Work (in BASIC)		£13.95
Dr Dobbs Journal Volume 1		£13.95
Dr Dobbs Journal Volume 2		£13.95
Dr Dobbs Journal Volume 3		£8.95
Best of Byte		£8.95
Scelbi BYTE Primer		£6.95
Best of Creative Computing, Vol 1		£5.95
Best of Creative Computing, Vol 2		£4.25
Program Design		£4.25
Numbers in Theory and Practice		£5.50
PIMS—A Database Management System		£6.50
Best of Interface Age—Software		£9.95
Programming the Z8000		£7.95
CPM Handbook		£8.95
K2 FDOS		£13.95
8086 Book		£11.25
Microsoft BASIC University Software Inc., Listings:		
Home and Economics Programs		£15.00
Education and Scientific Programs		£20.95
Small Business Programs		£29.50

FOR THE Z80

See Osborne Books!	
Z80 Instruction Handbook (Wadsworth)	£2.95
Programming the Z80 (Zacs)	£8.95
Z80 Software Gourmet Guide and Cookbook	£8.95
32 BASIC Programs for the TRS-80 (Level III) 16K	£10.10
Introduction to the T-Bug (Guide to TRS-80 Machine Language Monitor)	£4.50
30 Programs for the Sinclair ZX80	£6.95

FOR THE 6800

See Magazines and Subscriptions!	See Osborne Books!
6800 Software Gourmet Guide and Cookbook	£7.15
6800 Tracer—An aid to 6800 Program Debugging	£3.95
Tiny Assembler	£5.75
RA 6800 ML—An M6800 Relocatable Macro Assembler	£15.95
Link 68—An M6800 Linking Loader	£5.50
MONDEB—An Advanced M6800 Monitor Debugger	£3.50

CONCERNING LANGUAGE

A Practical Introduction to PASCAL	£3.95
Beginners guide to UCSD PASCAL	£7.50
Introduction of PASCAL (Including UCSD PASCAL)	£8.70
BYTE Book of PASCAL	£16.25
SCELBAL—BASIC Language Interpreter (Source Code)	£15.00
Instant BASIC	£6.95
BASIC BASIC	£6.50
Advanced BASIC	£6.00
Users Guide to North Star BASIC	£10.00
Microsoft BASIC (a guide)	£6.50
Secret Guide to Computers	£4.00
Fifty BASIC Exercises	£8.95

FOR THE 6502

See Magazines and Subscriptions! See Osborne Books!

FOR THE 6502

Best of Micro, Vol 2	£5.50
Programming the 6502 (Zacs)	£7.95
6502 Applications	£7.95
6502 Software Gourmet Guide and Cookbook	£7.25
The PET Revealed	£10.00
32 BASIC Programs for the PET	£10.10
First Book of KIM	£7.00
PET/CBM Personal Computer Guide	£10.00
Library of PET Subroutines	£10.00

FOR THE 8080

See Osborne Books!	
8080 Hex Code Card	£1.95
8080 Octal Code Card	£1.95
8080 Software Gourmet Guide and Cookbook	£7.15
8080/8085 Software Design	£6.75
8080 Standard Monitor	£9.95
8080 Standard Assembler	£9.95
8080 Standard Editor	£9.95
8080 Special Package: Monitor, Editor, Assembler	£20.00
BASEX: A simple Language and Compiler for the 8080	£5.50

FOR FUN

BASIC Computer Games	£5.00
More BASIC Computer Games	£5.50
8080 Galaxy Game	£6.95
SUPER-WUMPUS—A Game in 6800 Assembler Code & BASIC	£4.25
Computer Music Book	£6.75
Computer Rage (a Board Game)	£6.95
Games, Tricks and Puzzles for a Hand Calculator	£2.49
Introduction to TRS-80 Graphics	£5.75
Take My Computer Please... (Fiction)	£3.25
Introduction to Low Resolution Graphics for PET, Apple TRS-80	£5.50
Starship Simulation	£4.50
Microsoft BASIC: University Software Inc., Listings:	
Fun and Games Programs 1	£9.50
Fun and Games Programs 2	£9.50
6502 Games	£7.95

FOR THE NOVICE

See Magazines and Subscriptions!	See Osborne Books!
Getting Down to Business with Your Microcomputer	£5.50
Introduction to Personal and Business Computing	£5.50
Getting Involved with Your Own Computer	£5.50
How to Profit from Your Personal Computer	£6.50
Microcomputer Potpourri	£1.95
Hobby Computers are Here	£3.95
New Hobby Computers	£3.95
Understanding Microcomputers and Small Computer Systems	£6.95
Understanding Microcomputers and Small Computer Systems and Audio Cassette	£8.75
How to Make Money with Your Microcomputer	£5.75
From the Counter to the Bottom Line	£10.00
Buying a Business Computer	£9.75
You Just Bought a Personal What?	£7.95

MAGAZINES

MAGAZINE SUBSCRIPTIONS (all processed within 3 weeks)	
Micro 6502 Journal (12 issues)	£14.50
68 Micro (12 issues)	£18.00
Personal Computing (12 issues)	£18.00
Interface Age (12 issues)	£25.50
Dr Dobbs Journal (12 issues)	£16.00
Recreational Computing (6 issues)	£11.50
BYTE (12 issues)	£33.00
Creative Computing (12 issues)	£22.00
Kilobaud Microcomputing (12 issues)	£26.00
Compute for the 6502 (12 issues)	£22.00
80' Microcomputing (12 issues)	£25.00
S-100 Microsystems (for CPM users) (6 issues)	£10.50

MAGAZINE BACK ISSUES

Micro 6502 Journal	£1.75
Personal Computing	£1.95
Interface Age	£2.95
Dr Dobbs Journal	£1.95
Computer Music Journal	£3.75
Recreational Computing	£1.95
BYTE	£3.25
Creative Computing	£1.95
Calculators and Computers	£1.95
Kilobaud Microcomputing	£3.25
Compute—for the 6502	£2.25
68' Micro	£1.95
80-Microcomputing	£2.95
On Computing	£1.95
S-100 Microsystems	£1.95
Magazine Storage Box (holds 12)	£2.00

BYTE NIBBLE REPRINTS:

a) A TMS-9900 Monitor	£3.50
b) BASIC Cross-Reference Generator	£1.25
c) A Micro Word Processor	£4.50
d) "Tiny" PASCAL in 8080 Assembly Language ('e needed to use this)	£13.00
e) A "Tiny" PASCAL Compiler	£13.50
f) An APL Interpreter in PASCAL	£13.00
g) Computer Assisted Flight Planning	£2.35
h) Computerized Wine Cellar	£2.00
i) The Design of an M6800 Lisp Interpreter	£13.00

8-11 CAMBRIDGE HOUSE, CAMBRIDGE ROAD, BARKING, ESSEX IG11 8NT, ENGLAND.
Telephone: 01-591 6511 Telex: 892395

Byrom Software	BSTAM—Utility to link one microcomputer to another also using BSTAM BSTMS—Utility to link a micro to a mini or mainframe	£70/5 £95/10	Microfocus Ltd.	CIS COBOL version 4.3 FORMS 2	£425/25 £100/10
Compiler Systems	CBASIC v2.06	£65/15	Micropro Inc.	WORD-MASTER 1.7 TEX-WRITER 2.6 WORD-STAR 2.1 MAIL-MERGE 2.1 WORD-STAR with MAIL-MERGE SUPER-SORT: Version 1 Version 2 DATASTAR 1.1	£70/20 £35/15 £240/35 £70/10 £310/45 £120/20 £100/20 £165/20
Computer Plus	FMS 80 (File Management System)	£395/25	Microsoft Inc.	BASIC-80 BASIC Compiler 5.2 FORTRAN-80 COBOL-80 4.0 M/SORT EDIT-80 MACRO-80 MICROSEED MULISP MUMATH XMACRO-86 XFORTRAN-86	£175/17 £195/17 £220/17 £355/17 £70/11 £45/11 £80/11 £TBA/20 £TBA/20 £140/20 £185/11 £410/17
Computer Services	Bidirectional driver for Diablo Hytype printers for use on CPM & CDOS systems	£65/10	MT Microsystems	Pascal MT 5.1	£145/20
CP/M User Library	42 Volumes (one volume per disc) 8" 42 Volumes (one volume per 2 discs) 5" Index	£4/ £8/ £1/	Northshare	Multi-user system for Horizon Users 5.1	£40/5
Creative Computing	CS-9001 BASIC Games 1 CS-9002 BASIC Games 2 CS-9000 BASIC Games 1 and 2 CS-9003 ADVENTURE I.O. CS-9004 BILINGUAL Original Adventure CS-9005 BASIC Games 3 CS-9006 BASIC Games 4 CS-9007 BASIC Games 3 and 4 CS-9008 BASIC Games 1, 2, 3 and 4	£12/ £12/ £22/ £12/ £12/ £12/ £12/ £22/ £22/ £40/	Osborne & Associates	Accounts Payable & Accounts Receivable (disc only) General Ledger (disc only) Payroll with Cost Accounting (disc only)	£50/ £50/ £50/
Digital Research	(Most formats now available) MPM 1.1 CP/M 1.4 CP/M 2.2 CP/NET SID ZSID MAC TEX DESPPOOL PL/1	£175/18 £65/18 £90/18 £130/12 £45/12 £55/12 £55/12 £45/12 £30/5 £325/25	Phoenix Software Associates	PLINK—Disc to disc link loader PASM—Macro assembler PEDIT—Line editor with Macros BUG—Very powerful debug Package with all the above	£85/15 £85/15 £85/15 £85/15 £175/30
Information Unlimited	WHATSIT (Database Management System) on North Star on CP/M on APPLE 2:48k (requires int Basic) on APPLE 2:32k (requires int Basic) on ITT 2020 (see Apple)	£59/ £75/ £72/ £59/	Structured Systems	Sales Ledger Purchase Ledger Nominal Ledger Stock Control Letterright Analyst (File management Reporting System) NAD (Name and Address selection system) OSORT	£350/15 £350/15 £350/15 £350/15 £95/10 £115/10 £50/10 £50/10
KLH Systems	Spooler for CPM systems	£65/5	TDL Software	Business Basic ZTEL (Text Editing Lang.) MACRO II (Z80 Macro Assembler) LINKER DEBUG II (for 8080/Z80)	£80/ £35/ £35/ £35/ £45/
MPI Ltd.	Diablo driver runs 110 to 9600 baud for CP/M or CDOS Multiforth	£30/5 £65/20	Tiny-C Associates	Tiny-C language for 8080, 8085, Z80 systems	£50/35
Micah Inc.	CP/M for CDOS Users: Program to Expand CP/M system to be compatible with Cromemco CDOS software	£59/5	Supersoft Inc.	DIAGNOSTICS 1 TERM	£35/5 £65/5
Michael Shroyer Inc.	Electric Pencil Word Processor SSII for tty etc DSII for Diablo TRS-80 Cassette/disc.	£100/ £100/ £105/ £50/			

• Circle No. 108

ORDER INFORMATION

Software prices reflect distribution on 8" single density discs. If a format is requested which requires additional discs a surcharge of £4 per additional disc will be added.

Please add £3.00 for postage, packing and insurance plus VAT on ALL software items (including manuals) purchased. For overseas please add £4.50 per item.

If required, DATAPOST D service is available for an extra charge of £8.50.

Most software on this Advertisement is available from stock and a 72-hour return service is thereby offered on most prepaid orders. When ordering CP/M software please specify the format you require otherwise software will be dispatched on an 8" single density disc.

For more information on any of these items, please phone, write or visit. (We are open during office hours).

All publications are published in the U.S.A. and are stocked in Britain by L.P. Enterprises: M.P.I. Ltd.

We aim to keep all of these books in stock and as a

result of this most mail orders are despatched by return of post.

MAIL ORDER TELEPHONE ORDER VISIT

Send Cash, Cheque, Credit Card No., Postal Order, IMO to

L.P. Enterprises: MPI Ltd., Room PC, 11, Cambridge House, Cambridge Road, Barking, Essex. IG11 8NT. UK.

All Payment must be in sterling and drawn against a UK bank.

Subscriptions are processed to start with the next current issue, after the date of order

Please add £0.75 for postage on ALL books or magazines purchased.

These details are all current as of December 1980.

Prices are subject to change without notice, due to fluctuation in the dollar rate.

Trade Enquiries welcome. • Bulk Purchasers welcome.

OEM
terms
available

System Specifications

Twin Z80A's with 4MHz Clock Frequency One Z80A (the host processor) performs all processor and screen related functions. The second Z80A is "down-loaded" by the host to execute disk I/O. When not processing disk data, the second Z80 may be programmed by the host for other processor related functions.

8 bits

10 microseconds register to register

158

All interrupts are vectored

350K (700K on QD model) total bytes formatted on two double density drives. Optional 20.96 megabyte hard disk storage is available directly from Intertec.

250K bits/second

250 milliseconds, 35 milliseconds track-to-track.

4 1/4 inch mini-disk

300 RPM

32K bytes dynamic RAM. Expandable to 64K (socketed). 64K standard on QD model.

256 bytes of static RAM is provided in addition to the main processor RAM. This memory is used for program and/or data storage for the auxiliary processor.

1K bytes standard. Allows ROM "bootstrapping" of system at power-on. ROM storage is 2708 compatible and may be reprogrammed by the user for custom applications.

12-inch, specially focused, P4 phosphor, non-glare screen.

25 lines x 80 characters per line.

8 x 8 character matrix on a 8 x 10 character field.

Light characters on a dark background. Blinking or non-blinking.

20 MHZ.

Reversed image (block cursor).

Memory-mapped at 38 kilobaud. Serial transmission of data at rates up to 9600 bps.

Simplified RS-232 asynchronous. Parallel interface available.

Universal RS-232 asynchronous. Synchronous interface optional.

Printed circuit edge connector provided for connection of optional S-100

bus adaptor. Adaptor features internally mounted cardguide for up to

one S-100 type accessory.

Enables display of all incoming and outgoing control codes.

Choice of even, odd, marking, or spacing.

Half or Full Duplex. One or two stop bits.

Direct positioning by either discrete or absolute addressing.



SuperBrain users get exceptional performance for just a fraction of what they'd expect to pay. Standard SuperBrain features include: two double density mini-floppies with 350K bytes of disk storage, 32K of ram memory (expandable to 64K) to handle even the most sophisticated programs, a CP/M Disk Operating System with a high powered text editor, assembler, debugger and a disk formator. And, with SuperBrain's S-100 bus adaptor, you can add all the programming power you will ever need ... almost any type of S-100 compatible bus accessory. SuperBrain's CP/M operating system boasts an overwhelming amount of available software in BASIC, FORTRAN, COBOL, and APL. Whatever your application ... General Ledger, Accounts Receivable, Payroll, Inventory or Word Processing, SuperBrain is tops in its class. And the SuperBrain QD boasts the same powerful performance but also features a double-sided drive system to render more than 700K bytes of disk storage and a full 64K of RAM. All standard!

WIDELY USED IN U.K./FRANCE/U.S.A. AND ENGLISH SPEAKING COUNTRIES FOR ITS OVERALL FLEXIBILITY AS A COMPLETE BUSINESS PACKAGE.

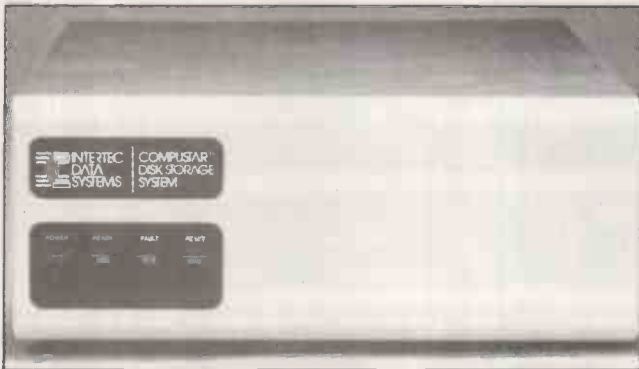

Our New CompuStar™ 10 Megabyte Disk Storage System (called a DSS) features an 8 inch Winchester drive packaged in an attractive, compact desktop enclosure. Complete with disk, controller and power supply. Just plug it into the Z80 adaptor of your SuperBrain and turn it on. It's so quiet, you'll hardly know it's there. But, you'll quickly be astounded with its awesome power and amazing speed. The secret behind our CompuStar DSS is its unique controller/multiplexor. It allows many terminals to "share" the resources of a single disk. So, not only can you use the DSS with your SuperBrain, you can configure multiple user stations using our new series of CompuStar™ terminals, called Video Processing Units or VPU's™.

The COMPUSTAR™ Family

VIDEO PROCESSING UNITS

Model 10 VPU

- 64K Internal Memory
- Integral CRT, CPU, & Keyboard
- Download programmable

Model 15 UPU (Universal Processing Unit)

- 64K Internal Memory
- Same features as VPU, less integral CRT and keyboard
- Can be used as a remote printer or a terminal interface device

Model 20 VPU

- 64K Internal Memory
- 350K Dual Disk Capacity
- Integral CPU, Disks, CRT & Keyboard

Model 30 VPU

- 64K Internal Memory
- 750K Dual Disk Capacity
- Integral CPU, Disks, CRT & Keyboard

Model 40 VPU

- 64K Internal Memory
- 1 1/2 MB Dual Disk Capacity
- Integral CPU, Disks, CRT & Keyboard

DISK STORAGE SYSTEMS (All feature our 255 user controller)

10 MB Winchester

- Shugart 8 inch mechanism
- Quiet, table-top operation
- Can be used with CompuStar or SuperBrain Video Terminals

32 MB Control Data CMD

- Cartridge Module Mechanism
- 16 MB fixed/16 MB removable
- Rack-mountable

96 MB Control Data CMD

- Cartridge Module Mechanism
- 80 MB fixed/16MB removable
- Rack-mountable

INCLUDES INVENTORY, DATABASE MANAGEMENT, INVOICING, MAILING ADDRESSES, STATEMENTS, SALES/PURCHASE LEDGER WITH OR WITHOUT AUTO STOCK UPDATE AND DOUBLE ENTRY JOURNALS INCLUDING NOMINAL LEDGER; PLUS A/C RECEIVABLE AND PAYABLE MAKING AUTO BANK ENTRIES.

- | | |
|--------------------------------|--------------------------------|
| 01 = ENTER NAMES AND ADDRESSES | 13 = PRINT CUSTOMER STATEMENTS |
| 02 = SALES INVOICES | 14 = PRINT SUPPLIER STATEMENTS |
| 03 = A/C RECEIVABLES | 15 = PRINT AGENT STATEMENTS |
| 04 = PURCHASE INVOICES | 16 = PRINT TAX STATEMENTS |
| 05 = A/C PAYABLES | 17 = RUN SEPARATE PROGRAMS |
| 06 = STOCK CONTROL | 18 = CHANGE VOCABULARY |
| 07 = ORDER CONTROL | 19 = PRINT YEAR AUDIT |
| 08 = BANK UPDATES | 20 = PRINT PROFIT/LOSS ACCOUNT |
| 09 = SALES LEDGERS | 21 = DISK DIRECTORIES |
| 10 = PURCHASE LEDGER | 22 = CASHFLOW FORECAST |
| 11 = INCOMPLETE RECORDS | 23 = PAYROLL (N/AVAILABLE) |
| 12 = USER DATABASE AREA | 24 = DISK SWAP/EXIT SYSTEM |

WHICH OPTION

DATABASE FEATURES ARE:

WITHIN THE LIMITS OF TWELVE FIELDS AND 256 CHARACTERS PER RECORD, ANY FILE ARCHITECTURE CAN BE DESIGNED WITH COMPLETE FREEDOM OVER THE LINGUISTIC CONVENTIONS ASSIGNED TO EACH FIELD. THE FILE THEN CAN STORE 32000 RECORDS WHICH CAN BE SEARCHED BY THE RANDOM ACCESS NUMBER (RETRIEVED IN LESS THAN ONE SECOND) OR SEQUENTIALLY COMPARING FOR LEFT FIELD PARTS, FIELD-INKEYS; OR PARTS OF RECORD, AND THEN CHANGED, PRINTED, DELETED, SKIPPED.

GRAMA (WINTER) LTD/G.W. COMPUTERS LTD. ARE THE PRODUCERS OF THIS PACKAGE WHICH IS UNEQUALLED FOR ITS LEVEL OF TOTAL INTEGRATION, LINGUISTIC FLEXIBILITY AND MAXIMISED DISK/MEMORY CONSERVATION. AUTHOR TONY WINTER (M.D.; B.A.LIT; B.A.HON.PHIL; AND LECTURER)

RESTRICTED DEMONSTRATIONS ONLY BY APPOINTMENT AT ONE OF OUR LONDON ADDRESSES DUE TO LONG TERM CONTRACTUAL COMMITMENTS. WE EXPORT TO ALL COUNTRIES; TAKE AMEXCO, ACCESS AND BARCLAYCARD. CONTACT TONY WINTER ON 01.636.8210 OR 01.631.4818 AND IF UNAVAILABLE THEN LEAVE A CALL-BACK MESSAGE (CLEARLY STATING YOUR TELEPHONE NUMBER AND NAME) ON THE 24 HOUR ANSWER-PHONE; WE CALL BACK ANYWHERE IN THE WORLD.

PRICE OF PACKAGE IS 975.00 (EXCLUDING MENU ITEMS 19,20,22,23) OR 1075.00 FOR THE FULL PACKAGE (23 AVAILABLE END YEAR, 19,20,22 BEING CURRENTLY INCLUDED). REQUIRES MBASIC-80 AND RUNS ONLY ON HARDWARE ON OUR PRICE LIST.

WE EXPORT TO ALL COUNTRIES CALLERS ONLY BY APPOINTMENT
CONTACT TONY WINTER ON 01.636.8210
89 BEDFORD COURT MANSIONS; BEDFORD AVENUE, LONDON W.C.1.

NOTE!!! LEVEL 9.00 TOTALLY IN CORE PROGRAM LEAVES MASTER DRIVE FREE (SAVING OF 200 POUNDS HARDWARE). IMPORTANT!!! NO HARDWARE IS ANY VALUE WITHOUT THE SOFTWARE. AND OUR SOFTWARE IS UNEQUALLED. WE GIVE YOU A DISCOUNT TO SET YOU GOING. JUST DECIDE ON THE SYSTEM YOU INTEND PURCHASING, AND TAKE 10% OF ITS VALUE OFF THE PRICE YOU WOULD HAVE TO PAY FOR THE SOFTWARE. YOU COULD GET THE SOFTWARE FREE WITH THE HARDWARE IF YOU CHOSE THE BEST SYSTEM WE SELL.

SUPERBRAIN *	SUPERBRAIN	COMPUSTAR *	COMPUSTAR	PRINTER *	PRINTER *	PRINTER
(+K + 320 K DISK	1850.00	64K MDL 10 VPU	1595.00	OKI MICRO-80		395.00
64K + 700 K DISK	2195.00	64K MDL 15 PRNT	1495.00	CENTRONIC 737		425.00
64K + 1.5 M DISK	2795.00	64K MDL 20VPU	2295.00	EPSON MX80		395.00
EMULATOR TERML	495.00	64K MDL 30 VPU	2495.00	TEXAS 810		1395.00
INTERTUBE III TML	495.00	64K MDL 40 VPU	2795.00	DIABLO 630		1595.00
16 MEG CDC H.DISK	3950.00	10 MEG INTERTEC	2950.00	NEC 5530		1595.00
40 MEG CDC H.DISK	4750.00	32 MED INTERTEC	7950.00	NEC 5510		1695.00
CORDLESS PHONES	135.00	96 MEG INTERTEC	8500.00	NEC 5525		1895.00
SHUGART DRIVES	95.00	BUS PROGRAM	975.00	QUME 5/55		1950.00
TRACTORS	150.00	BUS MANUAL	9.00	SHEET FEED		750.00
SHUGART 5 MEG DSK	1500.00	S100 CONTROLLER	750.00	CP.M (TM)		FREE.00
SYSTEM 1	3750.00	SYSTEM 2	5550.00	SYSTEM 3		7250.00
64K + 750 K DISK		64K + 5.3 M DISK		64K + 10.6 MEG		
CRT & S100 BUS		CRT & S100 BUS		CRT & S100 BUS		
IN 1 INTEGRAL UNIT		IN 1 INTEGRAL UNIT		IN 1 INTEGRAL UNIT		
CBASIC 80	150.00	FORTRAN -80	200.00	COBOL-80		320.00
CIS COBOL	420.00	PASCAL UCSD	275.00	WORD-STAR		195.00
MAIL MERGE	55.00	SUPER SORT	120.00	CBASIC		75.00
DATASTAR	190.00	BASCOMPILER	190.00	TEXTWRITER		75.00

OUR PRICE INCLUDES THE FOLLOWING FREE TRAINING SESSION (2 HOURS) DELIVERY 5/10/15/20 DISKS 'DEPENDING ON TOTAL SYSTEM' CABLES 6 MONTH WARRANTY 'MACHINE SWAP IF DEFECTIVE IN 3 WEEKS' 24/48 HOUR REPAIR SERVICE AT OUR OFFICES ALL ITEMS IN STOCK PAPER 'WITH PRINTER' 10% OF HARDWARE PRICE IN SOFTWARE AS FREE DISCOUNT RIBBONS & THIMBLES WHERE APPROPRIATE. TROUBLE—SHOOTING PROGRAMS AND SELECTIONS OF MOST IMPORTANT CHIPS AVAILABLE FOR 50.00. IF YOU WISH TO MAKE THE WARRANTY TO 1 YEAR THEN ADD 5% OF HARDWARE COST. OTHERWISE NO MAINTENANCE SCHEDULE, SIMPLE AD-HOC CHARGES AFTER WARRANTY EXPIRATION, SAME QUALITY SERVICE.

CALLERS ONLY BY APPOINTMENT AT ONE OF OUR LONDON OFFICES. TELS 01.636.8210 AND 01.631.4818 (TONY WINTER)

The quality of the new

SCRIPTA

daisywheel printer is astonishingly good

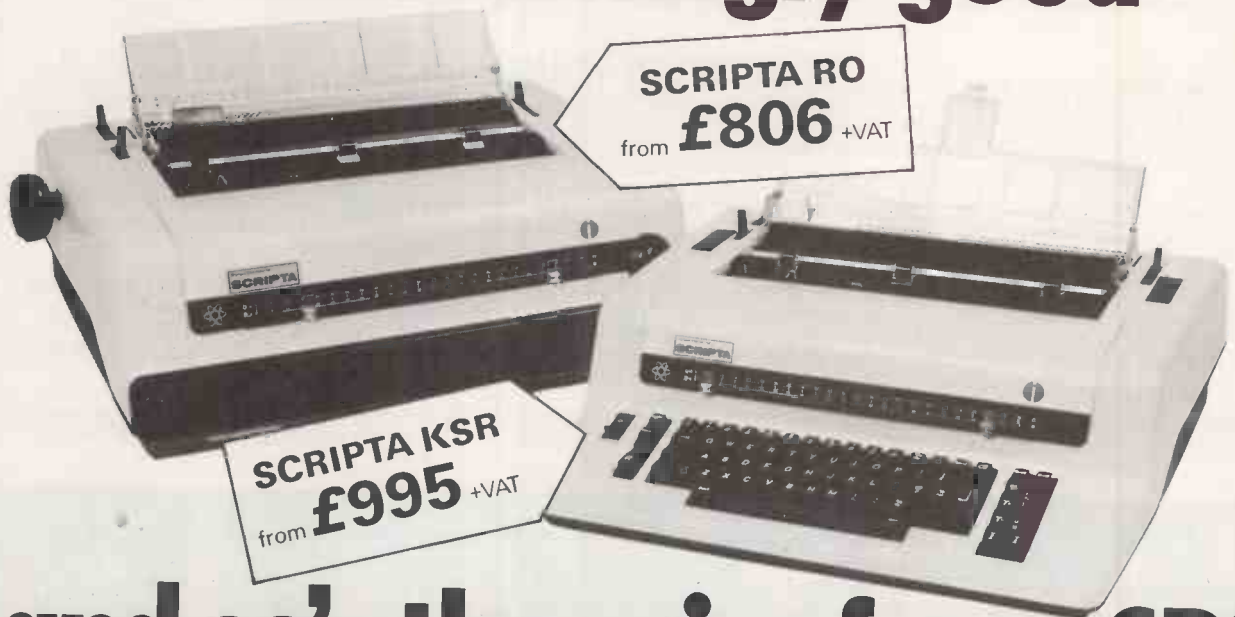

SCRIPTA RO
from **£806** +VAT

SCRIPTA KSR
from **£995** +VAT

-and so's the price from CPS

A lot is written about the quality of daisywheel printers, but how many people would be prepared to use one to make up an advertisement? **This paragraph was actually printed on a SCRIPTA RO daisywheel printer for reproduction in this advertisement.

Manufactured in West Germany by world renowned Olympia International.

The SCRIPTA RO (receive only) model and the SCRIPTA KSR model which incorporates a full electronic typewriter keyboard, including auto corrector facility.

Both models are available with IEEE, RS232 Serial and Parallel Interfaces. So if you have a COMMODORE, APPLE, TANDY, SUPERBRAIN, NORTHSTAR HORIZON, CROMENCO, SORCERER, SHARP, 380Z etc. etc. CPS have a SCRIPTA printer for you.

****Will your printer pass the CPS underline test?**

There is a choice of several different daisywheel type styles and both printers use low cost carbon ribbon cassettes.

The equipment comes with a 90 day warranty. CPS offer a full on-site maintenance contract.

You can buy, lease or hire your SCRIPTA from CPS.

Accessories available:

Rutishauser Tractor Feed **£175**+VAT

Rutishauser Cut Sheet Feed **£395**+VAT



Contact Nick Ashburner today at:-

CPS (DATA SYSTEMS) LTD

Third Floor, Arden House, 1102 Warwick Road, Acocks Green, Birmingham B27 6BH. Tel: 021-707 3866

A member of the CPS Group.

A quality wordprocessor from CPS is now only ***£2,785**+VAT (IBM 8032, 4040, SCRIPTA RO and WordPro 4) *including FREE Data Desk

HOW READY IS YOUR READY-MADE FACTORY?

Finding the right unit factory for YOU involves a lot more than square footage! What are you getting for your money? Will you have to pay for essential services? In Northampton we've been designing for Industry for over 10 years and know your needs better than most. Our unit factories are designed and built to a high finish and come complete with heating system, main services, offices & car parking.

All these features at rents around £2 per square foot make our 5000, 10 000 square feet and larger, unit factories, a shrewd choice if you need to move or expand—now!

And why Northampton? Find the M1's junction 15 on your motorway map for one very obvious reason. The town's traditional, no nonsense approach to doing business is another.

*in
Northampton
ready-made
means ready
NOW*

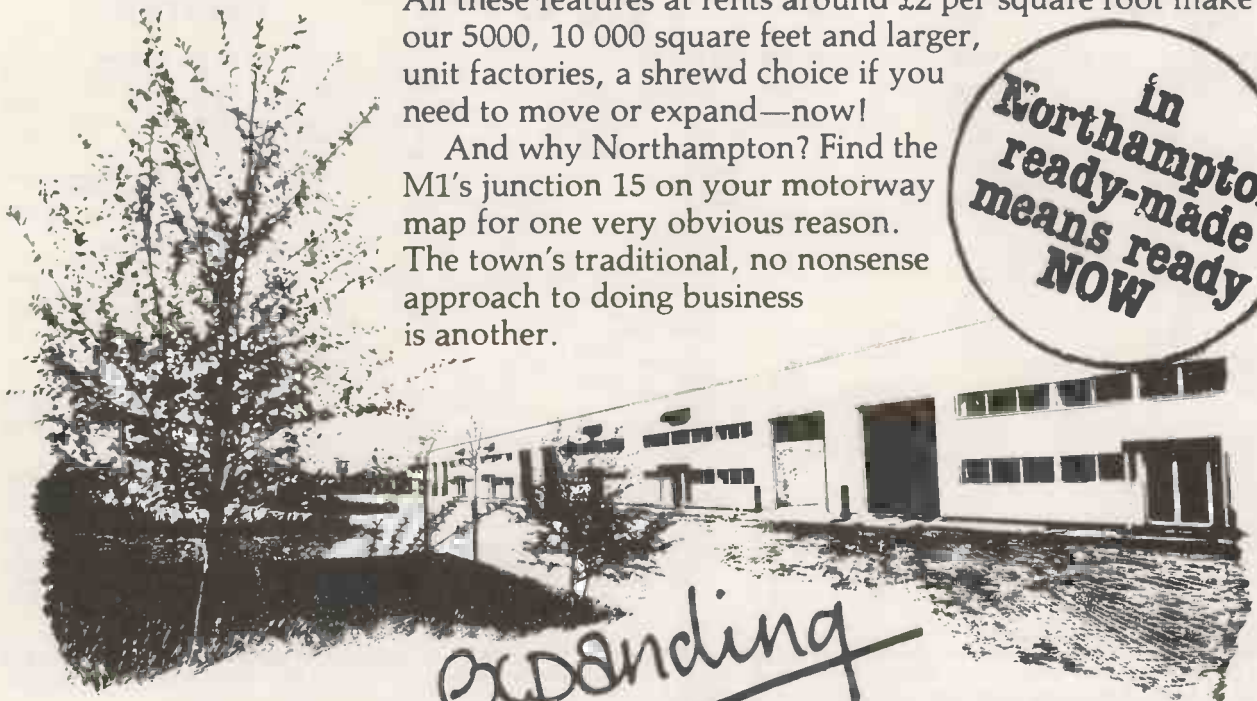

expanding

NORTHAMPTON

Contact Donald McLean on 0604 34734

Northampton Development Corporation, 2-3 Market Square, Northampton NN1 2EN

• Circle No. 111

Calisto Computers Ltd.

SPECIALISTS IN MICROCOMPUTERS AND SOFTWARE
119 JOHN BRIGHT STREET, BIRMINGHAM B1 1BE
Telephone: 021-632 6458

Our complete package offers you:

- Free initial discussion and advice
- Software Packages
- Supply and Installation
- Leasing and Financing Terms
- Maintenance Contracts
- Full After Sales Service

Apple

We offer a full range of equipment from the "Home/Hobbyist" type to the professional Business System. Ask about our "Starter packs". Prices from £700.00-£5000.00.

Sharp

We offer the full range of Sharp products from the PC-1211 Pocket Computer to the 48k MZ-80K with Disk Drives and Printers, we will also be stocking shortly the New Sharp PC-3200 computer system. Prices from £100-£3500.00.

Delta Systems

A range of Z80 based Micro-computers starting at 64k with 1Meg of 8" Floppy Disk Store, expanding to 512k with 34 Meg of Hard Disk Store and Tape Back-up. Prices from £2500-10500.00.

Approved Business Dealers for:

- Apple II Plus
- Delta Systems
- Sharp MZ80K
- Onyx Systems

As fully authorised Dealers for all the above equipment and as experienced computer professionals, we are the best people to assist you in choosing your computer system.

Onyx Systems

The C8000 series are a range of powerful small business computers from Onyx Systems. This state-of-the-art computer system combines high speed processors, memory, Winchester disk and cartridge tape drive in one efficient, compact package.

Industry-compatible versions of BASIC, COBOL, PASCAL and FORTRAN are available on several operating systems (eg. CP/M), along with communications software, wordprocessing and business application packages.

The C8000 series offers more features, better performance, higher quality and greater reliability than any other unit for the price. Prices from £6500-£15000.00.

We also supply a full range of printers both dot matrix and daisywheel, connection cables and also media (diskettes and disks), stationery (listing paper), ribbons etc. etc.

Contact us for all your requirements, write or telephone for full details and price lists.

THIS MONTH'S SPECIAL OFFER TELE VIDEO 912C TERMINAL

ANY QUANTITY **£485.00** + VAT

SOLE UK DISTRIBUTORS!!

**Instant Software™
NOW AVAILABLE
IN UK!!**

DEALER ENQUIRIES
INVITED

TRS 80 LEVEL II GAMES - Cassette <input type="checkbox"/> Air Mail Pilot £8.50 <input type="checkbox"/> Ball Turret Gunner £8.50 <input type="checkbox"/> Battleground £8.50 <input type="checkbox"/> Cosmic Patrol £12.50 <input type="checkbox"/> Dare Devil £8.50 <input type="checkbox"/> Dynamic Device Drivers £16.50 <input type="checkbox"/> Flight Path £8.50 <input type="checkbox"/> Invaders £8.50 <input type="checkbox"/> Investors Paradise £8.50 <input type="checkbox"/> Jet Fighter Pilot £12.50 <input type="checkbox"/> 1 Night Flight £8.50 <input type="checkbox"/> Orhelo £8.50 <input type="checkbox"/> Romrom Patrol/Tie Fighter £8.50 <input type="checkbox"/> Klingon Capture £6.50 <input type="checkbox"/> Space Trek IV £6.50 <input type="checkbox"/> Skirmish 80 £8.50 <input type="checkbox"/> Winners Delight £8.50 <input type="checkbox"/> Your Cribbage and Checkers Partner £8.50	<input type="checkbox"/> Kid Ventures £12.50 <input type="checkbox"/> Galactic Empire £12.50 <input type="checkbox"/> Ghost Train £12.50 <input type="checkbox"/> Mission Impossible £12.50 <input type="checkbox"/> Mystery Fun House £12.50 <input type="checkbox"/> Pirates Adventure £12.50 <input type="checkbox"/> Pyramid of Doom £12.50 <input type="checkbox"/> Slag £12.50 <input type="checkbox"/> Star Trek 3.5 £12.50 <input type="checkbox"/> Strange Odyssey £12.50 <input type="checkbox"/> The Count £12.50 <input type="checkbox"/> Voodoo Castle £12.50	<input type="checkbox"/> TRS 80 Utility £8.50 <input type="checkbox"/> TLDIS 16K, 32K, 48K £12.50 <input type="checkbox"/> The Disassembler 16K, 32K, 48K £8.50	Home (Personnel) Use <input type="checkbox"/> Body Buddy £8.50 <input type="checkbox"/> Energy Audit £40.50 <input type="checkbox"/> Personal Bill Paying £6.50	Business <input type="checkbox"/> Executive Expense Report Generator £8.50 <input type="checkbox"/> Oracle 80 £61.50 <input type="checkbox"/> Sales Analysis £20.50 <input type="checkbox"/> Terminal 80 £20.50 <input type="checkbox"/> The Wordslinger £24.50	Games <input type="checkbox"/> Adventureland/Pirate's Adventure/Mission Impossible Adventure (3 pack) £33.00 <input type="checkbox"/> Galactic Empire Galactic Trilogy £33.00 <input type="checkbox"/> Local Call for Death £16.50 <input type="checkbox"/> Mystery Fun House/Pyramid of Doom/Ghost Town (3 pack) £33.00 <input type="checkbox"/> Six Micro Stories £12.50 <input type="checkbox"/> Star Trek 3.5 £16.50 <input type="checkbox"/> Two Heads of the Coin £16.50 <input type="checkbox"/> Voodoo Castle/The Count/Strange Odyssey £33.00	Business Galactic Software Ltd <input type="checkbox"/> Mail list (Model 1 version) £31.50 <input type="checkbox"/> Mail list (Model 2 version) £162.50	TRS 80 Level I & II Education <input type="checkbox"/> Grade Book £8.50 <input type="checkbox"/> Ham Package 1 £6.50 <input type="checkbox"/> Electronics 1 £6.50 <input type="checkbox"/> Typing Teacher £8.50	Games <input type="checkbox"/> Air Flight Simulation £8.50 <input type="checkbox"/> Chessmate 80 £16.50 <input type="checkbox"/> Oil Tycoon £6.50 <input type="checkbox"/> Space Trek II £6.50 <input type="checkbox"/> Santa Poravia/Fiumaccio £6.50	Apple Disks Games <input type="checkbox"/> Air Flight Simulation £16.50	<input type="checkbox"/> Apple Fun £16.50 <input type="checkbox"/> Golf £6.50 <input type="checkbox"/> Mimic £6.50 <input type="checkbox"/> Oil Tycoon £8.50 <input type="checkbox"/> Paddle Fun £16.50 <input type="checkbox"/> Santa Poravia and Fiumaccio £8.50 <input type="checkbox"/> Sahara Warriors £6.50 <input type="checkbox"/> Space Wars £6.50 <input type="checkbox"/> Super Shooters £8.50 <input type="checkbox"/> Sky Bombers II £16.50	Education <input type="checkbox"/> Math Fun £16.50 <input type="checkbox"/> Math Tutor I £6.50 <input type="checkbox"/> Math Tutor II £6.50	Home (Personal) Use <input type="checkbox"/> Solar (Energy) Home £33.00	Business <input type="checkbox"/> Accountants Assistant £6.50 <input type="checkbox"/> Finance and Investment £16.50	PET Education <input type="checkbox"/> Ham Package 1 £6.50 <input type="checkbox"/> Electrical Engineer's Assistant £8.50	Utility <input type="checkbox"/> Pet Utility 1 £8.50	Games <input type="checkbox"/> Trek X £6.50 <input type="checkbox"/> Dungeon of Death £6.50 <input type="checkbox"/> Santa Poravia and Fiumaccio £8.50
SCOT ADAMS ADVENTURE INTERNATIONAL <input type="checkbox"/> Adventure Land £12.50	Education <input type="checkbox"/> IQ Test £8.50 <input type="checkbox"/> Teacher £8.50 <input type="checkbox"/> Vocabulary Builder £8.50	Misc. <input type="checkbox"/> Demo II £6.50 <input type="checkbox"/> Demo II £6.50 <input type="checkbox"/> TRS 80 Tests £8.50 <input type="checkbox"/> IRV £20.50	Video Speed-Reading Trainer <input type="checkbox"/> Word Watch £6.50	Utilities <input type="checkbox"/> BP A Basic Programming £12.50 <input type="checkbox"/> TRS 80 Utility £8.50	Scot Adams Adventure International <input type="checkbox"/> Adventure/Pirates Adventure/Mission Impossible Adventure (3 pack) £33.00 <input type="checkbox"/> Asteroid £16.50 <input type="checkbox"/> Mystery Fun House/Pyramid of Doom/Ghost Town (3 pack) £33.00 <input type="checkbox"/> Voodoo Castle/The Count/Strange Odyssey (3 pack) £33.00											

Instant Software Support System

Instant Software offers a special support and reporting system to enable the users of our software to get the very best support and advice on how to gain the maximum benefit from our products. Enquiries will be actioned promptly to provide a first class service.

*TRS-80 Trademark of Tandy Corp. CP/M Trademark of Digital Res.

CBasic Trademark of Compiler Systems. Apple Trademark of Apple Inc.

E&OE

Please use this page as an order form: Tick program required

Name

Address

Tel:

Cheque/PO No.

All prices include VAT @ 15% packing & return postage to U.K. addresses.
Send 50p. for descriptive Catalogue.

PCS/81

LOBO'S NEW LDOS puts muscle in your TRS-80*

LOBO DRIVES' new LDOS* Disk Operating System is loaded with new outstanding features that will enable you to realise the full power and potential of your TRS-80*. With LDOS, you can support up to eight drives (5" and 8" drives, double-sided drives, double density drives, 80 track drives), including the new 8" and 5" Winchester fixed disk drives, in any combination.

Other LDOS muscle building features include:

ISAM accessing techniques; keyboard typeahead; Graphic string packer; Dated files; Marked files; File transfer by class; Built-in lowercase display drivers; Non-breakable AUTO and DO commands, and many, many more.

LDOS is the perfect operating system to use with your expansion interfaces and disk subsystems.

*TRS-80 is a registered trademark of Radio Shack & Tandy Company.

SPECIAL INTRODUCTORY OFFER £99

• Circle No. 112

PRACTICAL COMPUTING May 1981

• Circle No. 113

THE SHARP MZ-80K HAS GOT IT ALL



Since its introduction the Sharp MZ-80K has proved to be one of the most successful and versatile microcomputer systems around. Sharp now have a comprehensive range of products ready to make the powerful MZ-80K with its Printer and Disc Drives even more adaptable.

Products include: - Universal Interface Card, Machine Language and Z-80 Assembler packages, CP/M* plus a comprehensive range of software.

*Trade mark of Digital Research Ltd.

You'll find all the help and advice you need about the MZ-80K at your Specialist Sharp Dealer in the list below.

If there is no dealer in your area, or if you require any further

information write to:-
Computer Division,
Sharp Electronics (UK) Ltd.,
Sharp House, Thorp Road,
Newton Heath,
Manchester M10 9BE.



Computers that talk your language.

GET IT ALL HERE ...

AVON
BCG SHOP EQUIPMENT LTD
Bristol, Tel: 0272 425338
DECIMAL BUSINESS M/Cs LTD
Bristol, Tel: 0272 294591
BEDFORDSHIRE
H.B. Computers (Luton) Ltd
Luton, Tel: 0582 416887
BERKSHIRE
Newbear Computing Store Ltd
Newbury, Tel: 0635 30505
BIRMINGHAM
Camden Electronics
Small Heath, Tel: 021-773 8240
E.B.S. Ltd
Birmingham 1, Tel: 021-233 3045
Newbear Computing Store Ltd
Birmingham B26, Tel: 021-707 7170
BUCKINGHAMSHIRE
Interface Components Ltd
Amersham, Tel: 02403 22307
CESHIRE
Charleshworth of Crewe Ltd
Crewe, Tel: 0270 56342
Cash Register Services
Chester, Tel: 0244 317549
Fletcher Worthington Ltd
Hale, Tel: 061-928 8928
Newbear Computing Store Ltd
Stockport, Tel: 061-491 2290
CLEVELAND
Hunting Computer Services Ltd
Stockton-on-Tees, Tel: 0642 613021
DERBYSHIRE
Lowe Electronics Ltd
Matlock, Tel: 0629 2817
DEVON
Crystal Electronics Ltd
Torquay, Tel: 0803 22699

EXETER
Peter Scott (Exeter) Ltd
Exeter, Tel: 0392 73309
DORSET
South Coast Business M/Cs
Ferndown, Tel: 0202 893040
ESSEX
Prorole Ltd
Westcliff-on-Sea, Tel: 0702 335298
GLOUCESTERSHIRE
Gloucestershire Shop Equipment Ltd
Gloucester, Tel: 0452 36012
HAMPSHIRE
Advanced Business Concepts
New Milton, Tel: 0425 618181
Xitan Systems Ltd
Southampton, Tel: 0703 38740
HERTFORDSHIRE
King Pin Computers
Stevenage, Tel: 0438 59677
KENT
Video Services (Bromley) Ltd
Bromley, Tel: 01-460 8833
LANCASHIRE
B & B Computers Ltd
Bolton, Tel: 0202 26644
H.R. Control Systems Ltd
Chorley, Tel: 02572 75234
Sound Service
Burnley, Tel: 0282 38481
Sumita Electronics Ltd
Preston, Tel: 0772 55065
LEICESTERSHIRE
Arden Data Processing
Leicester, Tel: 0533 22255
Gilbert Computers
Lubenham, Tel: 0858 65894

Leicester Computer Centre
Leicester, Tel: 0533 556268
LINCOLNSHIRE
Butel-Comco Ltd
Hendon, Tel: 01-202 0262
Central Calculators Ltd
London EC2, Tel: 01-729 5588
Digital Design & Development
London W1, Tel: 01-387 7388
Euro-Calc Ltd
London WC1, Tel: 01-405 3223
Euro-Calc Ltd
London EC2, Tel: 01-729 4555
Euro-Calc Ltd
London W1, Tel: 01-636 5560
Keen Computers Ltd
London EC1, Tel: 01-248 7307
Lion Computer Shops Ltd
London W1, Tel: 01-637 1601
Personal Computers Ltd
London EC2, Tel: 01-626 8121
Scope Ltd
London EC2, Tel: 01-247 8506
Sumlock Bondain Ltd
London EC1, Tel: 01-253 2447
MANCHESTER
Sumlock Electronic Services Ltd
Manchester 3, Tel: 061-834 4233
Sumlock Software Ltd
Manchester M3,
Tel: 061-228 3502

MERSEYSIDE
Microdigital Ltd
Liverpool, Tel: 051-227 2535
Sota Communication Systems
Liverpool L14, Tel: 051-480 5770
MIDDLESEX
Cream Computer Shop
Harrow, Tel: 01-380 0833
NORFOLK
Sumlock Bondain (East Anglia)
Norwich, Tel: 0603 26259
NORTHAMPTONSHIRE
H. B. Computers Ltd
Kettering, Northamptonshire,
Tel: 0536 520910
NORTHERN IRELAND
O & M Systems
Belfast, Tel: 0232 49440
NOTTINGHAMSHIRE
Keen Computers Ltd
Nottingham, Tel: 0602 583245
Mansfield Business M/C Ltd
Mansfield, Tel: 0623 26610
OXFORDSHIRE
Oxford Computer Store
Oxford, Tel: 0865 45172
REPUBLIC OF IRELAND
O'Connor Computers Ltd
Galway, Tel: 0009 61173
Tomorrows World Ltd
Dublin 2, Tel: 0001 776861
SALOP
Computer Corner
Shrewsbury, Tel: 0743 55166
SCOTLAND
A & G Knight
Aberdeen, Tel: 0224 630526
Business and Electronics M/Cs
Edinburgh, Tel: 031-226 5454

Micro Centre
Edinburgh, Tel: 031-556 7354
Microforth
Dunfermline, Tel: 0383 34954
Moray Instruments Ltd
Elgin, Tel: 0343 3747
Pointer Business Equip Ltd
Glasgow, Tel: 041-332 3621
Robox Data Systems Ltd
Glasgow, Tel: 041-221 5401
Tysael Computers Ltd
Aberdeen, Tel: 0224 573111
SOMERSET
Norsett Office Supplies Ltd
Cheddar, Tel: 0934 742184
SOUTH HUMBERSIDE
Silicon Chip Centre
Grimby, Tel: 0472 45353
SOUTH WALES
City Radio
Cardiff, Tel: 0222 28169
STAFFORDSHIRE
W. B. Computer Services
Cannock, Tel: 0543 75555
SUFFOLK
C. J. R. Microtek Co. Ltd
Ipswich, Tel: 0473 50152
SURREY
Petalect Electronic Services
Woking, Tel: 04862 69032
R.M.B. Ltd
Croydon, Tel: 01-684 1134
Saradan Electronic Services
Wallington, Tel: 01-669 9483
T & V Johnson (Microcomputers)
Camberley, Tel: 0276 20446
SUSSEX
M & H Office Equipment
Brighton, Tel: 0273 697231

TYNE & WEAR
P.M.S. Ltd
Sunderland, Tel: 0783 480009
WALES
Limrose Electronics Ltd
Wrexham, Tel: 097 883 5555
Morriston Computer Centre
Swansea, Tel: 0792 795817
Sigma Systems Ltd
Cardiff, Tel: 0222 21515
WARWICKSHIRE
Business & Leisure Microcomputers
Kenilworth, Tel: 0926 512127
YORKSHIRE
Bits & P.C's
Wetherby, Tel: 0937 63744
Datron Micro-Centre Ltd
Sheffield, Tel: 0742 585490
Huddersfield Computer Centre
Huddersfield, Tel: 0484 20774
Neccos (D.P.) Ltd
Darlington, Tel: 0325 69540
Quadruphenia Ltd
Sheffield, Tel: 0742 77824
Ram Computer Services Ltd
Bradford, Tel: 0274 391166
Yorkshire Electronic Servs.
Leeds, Tel: 0532 522181

Erase Eproms in 8 minutes for under £100

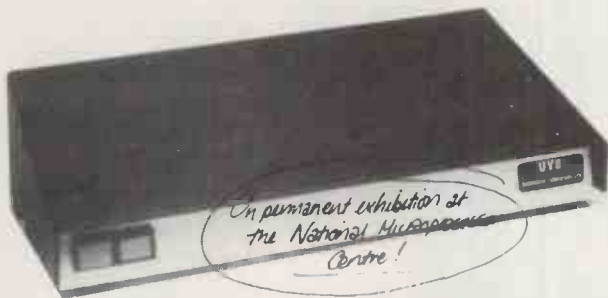

The high speed, high capacity model UV8 sets new performance and price standards.

- Cuts typical erasure times by a factor of 5
- 8 MINUTE SOLID STATE TIMER
- Capacity up to 14 EPROMS
- 2708 type erased in 4 to 7 minutes
- High intensity 254 NM UV source
- Safety interlock automatically starts timing sequence
- Audio tone signals erasure cycle complete
- Internal switch to extend erase time.

MICRODATA Computers Ltd, Belvedere Works, Bilton Way, Pump Lane Industrial Estate, Hayes, Middlesex.

Telephone (01) 848 9871 (6 lines) Telex 934110

• Circle No. 114

THE COMPLETE DATA ENTRY RETRIEVAL AND UPDATE SYSTEM FOR YOUR MICRO



DataStarTM

Takes the drudgery of out data-entry programming!

Use DataStar to generate screen layouts, validate data input and update files.

DataStar has horizontal and vertical scrolling facilities for large forms, and performs search/retrieval and arithmetic operations. Produced by MicroPro International, the company that created the famous WordStar word-processing software.

DataStar is the complete data entry and retrieval package for £180; manual available for £29, refundable against purchase of software. Runs on Z80/8080/8085 micros under CP/M or CP/M compatible operating systems.

CONTACT US TODAY!

HELISTAR SYSTEMS LTD.

150 WESTON ROAD, ASTON CLINTON,
AYLESBURY, BUCKS HP22 5EP.

• Circle No. 115



L&J COMPUTERS

3 CRUNDALE AVENUE, KINGSBURY NW9 9PJ 01-204 7525

THE "PET" SPECIALISTS



NEW LOW, LOW, 'PET' PRICES!!

Pet 8K (Large keys)	£420*
16K	£499*
32K	£630*

Ext cassette decks (+ counter) £ 55*

PET Friction Feed printers £350*

AVAILABLE FROM STOCK + VAT

Printers Disc Drives Sundries

PET 3023 PET 3040

PET 3022 Compu 400K

Centronic 779 Compu 800K

Spinwriter Interfaces

**TRY US!
YOU WILL NOT BE
DISAPPOINTED**

SUPERPETS NOW EX-STOCK!

Tool kits: library cases

Disks: C12 Cassettes

Paper (roll & tractor feed)

Labels: Dust covers

SPECIALS FOR THIS MONTH:

PETMASTER SUPERCHIPS — UPGRADE YOUR PET EVEN MORE!

A FEW ONLY: Brand New CENTRONIC 779 t/f printers £590*
Brand New PET 2023 f/f printers £320*

THE "MUPETS" ARE HERE!

3 TO 8 PETS ONLY NEED 1 DISK DRIVE...

Daily demonstrations: Ring for details.



**COMPLETE SYSTEMS
FROM £1700!!**

THE SYSTEMS WE SUPPLY & INSTALL ARE COMPLETE:
ESTIMATES GIVEN FREE WITH NO HIDDEN EXTRAS:
FULL BACK-UP: GUARANTEED EXPERTISE.

• PRICES DO NOT INCLUDE VAT

PERSONAL SHOPPERS WELCOME
Phone & Mail Orders accepted.

SOFTWARE

As well as a full range of Petsoft and Commodore Software, we have some highly reliable "Home-Brewed" programs available.

STOCK CONTROL & INVOICING £60
(Handles up to 500 items — 32K) (180 on 16K). Stock depleted on invoicing, search etc. Cassette, disk (& print option).

CASH BOOK £90
Enter daily/weekly amounts — printout and totals, weekly/monthly analysis, totals and balances.

MACHINE HIRE Typewriter & Plant Hire Firms. £420

STOCK TAKING Cuts out all the hard work £230

OUTSIDE SERVICES (For Mini-Cabs Etc) £220

Sae for free software booklet

Specialists in: Commodore Business Programs
Bristol Trader, Item & Monitor
Superpay Word Processing

**SPECIALISED SOFTWARE APPLICATIONS
UNDERTAKEN. RING FOR DETAILS**

2 FOR JUST OVER THE PRICE FOR 1!

We now have limited stock of NEW
CASSETTE DECKS, with built-in
COUNTER + SOUND BOX FOR PETS.
AT ONLY £65* EACH.
Orders dealt with in strict rotation

ALL GOODS SENT SAME DAY WHEREVER POSSIBLE
LARGE S.A.E. FOR LISTS ETC.



• Circle No. 116

CHROMASONIC electronics

48 JUNCTION ROAD, ARCHWAY, LONDON N19 5RD 100 yds FROM ARCHWAY STATION & 9 BUS ROUTES
 TELEPHONE 01-263 9493 263 9495

YOUR SOUNDEST CONNECTION IN THE WORLD OF COMPONENTS AND COMPUTERS

PETS & SYSTEMS

8N 8K RAM	£399
16N 26K RAM	£499
32N 32K RAM	£599
CASSETTE DECK	£55

343K Twin Floppy Disk
 £695



COMPLETE 32K SYSTEM £1789

NEW 32K with 80 col Screen £825
 Twin Disk Drive 950K £895

All with new keyboard
 and green screen
 Friction Feed Printer
 £375
 Tractor Feed Printer
 £425

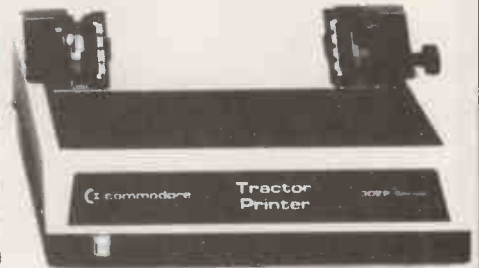

MEMORY EXPANSION KIT

Suitable for UK101. Superboard expansion using 2114's each board has 16K ram capacity kit contains:

- ★ On board power supply
- ★ 4K Eprom expansion
- ★ Fully buffered for easy expansion via 40 pin socket
- ★ 8K kit £79.95
- ★ 16K kit £106.95
- Printed Circuit Board £29.95
- 40 pin - 40 pin header plug £8.50

COLOUR BOARD

Available at long last.
 Please write or phone
 for details. **£84.95**

NEW SHOP



VIDEO GENIE

based on TRS80



Utilises Z80, 12k level II Basic,
 Integral Cassette Deck, UHF O/P.
 16k RAM,
 all TRS80 features

£289

CASES

Available for
 U.K. 101. Superboard
 Nascom.
 Appx. DIM. 17" x 15"
 435 x 384 mm

PRICE £24.50

Post & Packing £1.50

UK101 P.P.I.

BUILT & TESTED. INTERFACES TX80
 PRINTER DIRECT, CAN BE
 PROGRAMMED TO OPERATE RELAYS,
 MOTORS, VARIOUS OTHER
 PERIPHERALS 'CENTRONICS
 COMPATIBLE' PLUS INTO IC SOCKET.
 RED !!!!! DISPLAY LED BINARY DISPLAY
 FULL DOCUMENTED **£29.95**

UK101

£179 IN KIT FORM
£229 READY BUILT
 & TESTED
£255 COMPLETE
 IN CASE

4K EXPANSION
 (8 x 2114)
 now only **£14.00**

No extras required

- ★ Free sampler tape
- ★ Full Qwerty keyboard
- ★ 8K basic
- ★ Ram expandable to 8K on board (4K inc)
- ★ Kansas City tape interface

★ **NEW MONITOR** ALLOWS FULL EDITING & CURSOR CONTROL
£22.00



PRINTERS

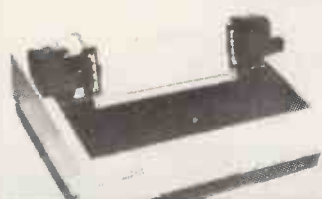

EPSON TX80 £295
EPSON MX80 £359

Dot-matrix printer with Pet
 graphics interface: Centronics
 parallel, options: PET, Apple and
 serial.

BARCLAYCARD

VISA

Please add VAT 15% to all prices. Postage on computers, printers and cassette decks charged at cost, all other items P&P 30p. Place your order using your Access or Barclaycard. (Min. tel order £5). Trade and export enquiries welcome, credit facilities arranged.



• Circle No. 117

LONDON COMPUTER CENTRE

EPSON MX80 FT £395

WITH

DUAL PRINT MODES

+ ROLLER ATTACHMENT

CORRESPONDENCE QUALITY AND STANDARD DOT MATRIX IN ONE LOW COST UNIT

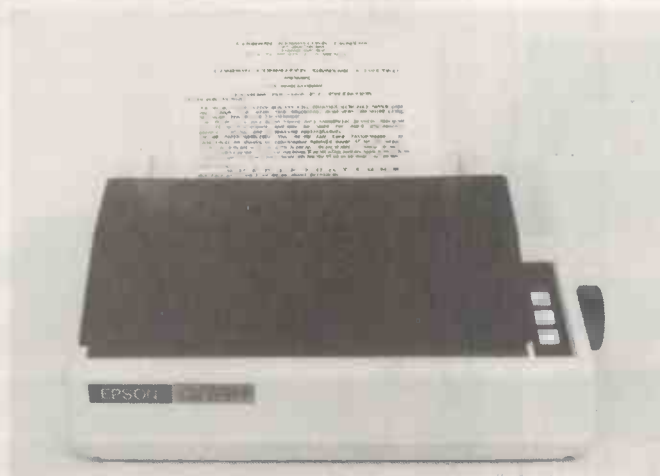

LETTER LIKE PRINT QUALITY

3-WAY PAPER HANDLING

1. Letterheads or A4
2. Fanfold
3. Paper Rolls

LOW NOISE

The quietest dot Matrix Printer

132 COLUMNS PER LINE

Directly replaces big, expensive printers, eg: Texas 810, Centronics 700

HIGH RELIABILITY

Precision engineered by Shinshu Seiki a subsidiary of Seiko Watch Co. of Japan

Dial 01-388 6991/2

For fast action and service

FOR A DEMONSTRATION CALL INTO:

43 GRAFTON WAY, LONDON W1P 5LA (Opposite Maples)

Tel: 388 6991/ 2 OPENING HOURS: 11-7 MON-FRI 12-4 SAT

24 hour answer phone: 01-388 5721

• Circle No. 118

NewBear

Computing Store Ltd



**BETTER PRICES!
BETTER DELIVERY!
WIDEST RANGE OF
SOFTWARE**

For the best deal
from the largest
sharp dealer
phone Newbear
(0635) 30505

SHARP

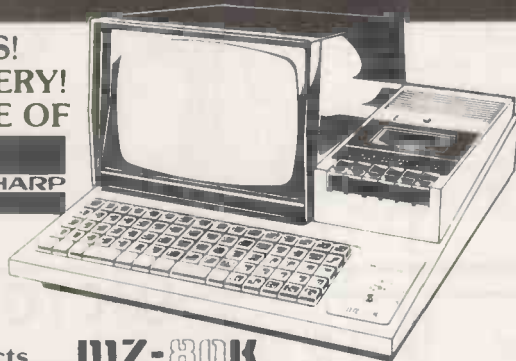

MZ-80K

Many unique products
Zen/Listings/Word Proc.

Apple
II plus

apple



For ex-stock delivery
12 months warranty

**ACORN
PROM PROGRAMMERS**

**PROM ERASERS
KEYBOARDS**

**5 1/4 AND 8"
DISC DRIVES**

**WIDEST RANGE
OF BOOKS IN U.K.**

**and Bear care
Bear Bargains**

**NORTH
STAR**

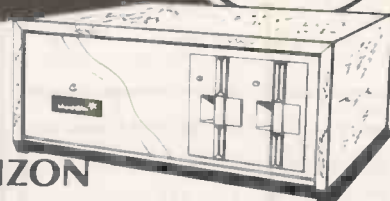

★ HORIZON

Installed on your site with full field
service anywhere in U.K. fully C.P.M.
compatible. Chosen by Newbear for
its reliability and performance.

64K Dual Drive Quad	£1995.00
North Star Horizon	
Newbury Laboratory 7009 terminal	£795.00
Citoh8300 R.M. Printer	£499.00
CPIM 2.2.	£95.00

Please send urgently:

Sharp **A**
 North Star Horizon Cat.
 Booklist Citoh N.L. Terminals
 Please contact me Phone No.
 Name
 Address

PCS/81

NEWBEAR COMPUTING STORE LTD. (HEAD OFFICE)
 40 BARTHOLOMEW STREET, NEWBURY, BERKS
 TEL. (0635) 30505 TELEX 848507 NCS
 FIRST FLOOR OFFICES, TIVOLI CENTRE, COVENTRY ROAD,
 BIRMINGHAM. TEL. 021 707 7170
 220-222 STOCKPORT ROAD, CHEADLE HEATH, STOCKPORT.
 TEL. 061-4912290

• Circle No. 119

PROFESSIONAL SUPERBRAIN SOFTWARE

COMPILERS & UTILITIES

Microfocus CIS COBOL:

- Standard compiler..... £425
- Forms-2 utility £100

NB We are the sole UK distributors of Microfocus products on the SUPERBRAIN.

Microsoft:

- MBASIC interpreter £155
- BASIC 80 compiler £200
- COBOL 80 compiler £390
- FORTRAN 80 compiler £260
- MACRO 80 assembler £ 85

Micropro:

- WORDSTAR (word-processing) ... £230
- Mailing list merge for above £ 65
- DATASTAR (data management) .. £160
- SUPERSORT £130

The Micro Solution Ltd:

- REPORT GENERATOR £100

(this superb data management tool allows you to produce interactively a COBOL program to select records from a file and print them in your layout)

- BSTAM (inter machine Transfer)... £ 75

APPLICATIONS SOFTWARE

The Micro Solution Ltd:

- Integrated Accounting System £750
- Stock Control System £400
- Bill of Materials System £400

These three modules interlock as required to make a superb total business system.

Half day free training is included in the above price for each module.

The Accounting system includes:

- Sales/Purchase/Nominal Ledgers + VAT
- Final Accounts/Profit & Loss/Bal sheet
- Invoicing
- Open Item or Balance Forward

The Stock Control system includes:

- Order processing/Auto. Reordering
- Picking List production

Others:

- Television Rental system £800
- Estate Agents' system £475
- CP/M Specials (Auto Load etc) ... POA

SUPERBRAINS AVAILABLE FROM STOCK,

FROM **£1600** Subject to exchange rate fluctuation

ADD VAT AT STD. RATE TO ALL ABOVE PRICES
POSTAGE AND PACKING WILL BE ADDED
DELIVERY NEXT DAY FOR STOCK ITEMS

** CASH WITH ORDER — DELIVERY FREE

DEALER ENQUIRIES WELCOME



Contact:



Park Farm House
Heythrop
Chipping Norton
OXFORDSHIRE
OX7 5TW

telephone:
CHIPPING NORTON (0608) 3256
ask for: Bill Whaley
or
Bede Dunlop

• Circle No. 120



**CRYSTAL ELECTRONICS
CC ELECTRONICS**

SHARP MZ80K

**For the latest competitive
PRICE**

Contact us

Before you accept discounts elsewhere.

GIVE US A TRY

**CRYSTAL ELECTRONICS is the home of XTAL BASIC
ACCLAIMED BY MANY**

Bi-directional serial board for your SHARP RS232 compatible < 150 Baud to > 2400 Baud adjustable. 5,6,7,8 Bit words, plugs into MZ80 I/O £99.50 plus VAT

**MZ80K owners — are you XTAL followers?
NO! Then please read on.
XTAL BASIC (SHARP)**

Takes 5K less memory, has all the features of SHARP BASIC PLUS Multi dim strings, error trapping, logical operators, machine code monitor, more flexible peripheral handling, improved screen control, increased list control, auto run, If.. then.. else — and it doesn't stop there — it grows. You can extend the commands and functions at will — 10K, 12K, 16K, BASIC?

SHARP to XTAL BASIC conversion program is included. £40 plus VAT

Members of Computer Retailers Association & Apple Dealers Association

Shop open 0930-1730 except Saturday & Sunday

40 Magdalene Road, Torquay, Devon, England. Tel: 0803 22699

Telex 42507 XTAL G

Access and Barclaycard welcome.



COMPUTERS
AND
COMPONENTS



• Circle No. 121

FROM LEADING MANUFACTURER

£3.95

NEW



2708

£2.50

2732

£11.00

COMPLETE EPROM SERVICE

➤ COPYING

➤ ERASING

➤ CUSTOM PROGRAMMING EG TWO 2708 INTO ONE 2716 and ADDRESS CHANGES ETC (all prices subject to VAT p+p 60p)



THIS COULD BE FUN (LEISURE) LTD.

307 New Kings Rd., London SW6 4RF.

Tel. 01-736 5503/4

• Circle No. 122

1, Montague Street,
London WC1B 5BP

Telephone: 01-580-9792
Telex: MTW 888941 LCCI G

DRAMATIC SPEED INCREASE for CP/M systems

Is your system painfully slow? Is it forever disk-bound? Do the alternatives look prohibitively expensive? Is 64K of RAM insufficient? At last there is a neat, cost effective solution —

THE SILICON DISK SYSTEM

This remarkable, innovative software package from J.K. Systems Research Ltd., with the addition of standard RAM, enables your microcomputer to challenge the performance of many minicomputers. Furthermore, this can usually be done without making any changes to your existing application software.

THE SILICON DISK SYSTEM will run on most CP/M and MP/M systems. It allows additional RAM to be controlled in such a manner as to appear as a super-fast additional disk drive. This memory is organised using the standard CP/M file structure and therefore can be accessed by program like any other disk drive.

This form of memory management gives rise directly to:

- (i) **Extended Memory Addressing Capability — up to 8 megabytes of RAM!**
- (ii) **Very fast file accessing — typically 500 times as fast as floppy discs!**

Sorting and searching long index files, lengthy compilations, database assessing and many other of those disk-bound activities which take too long on floppy or even hard disk systems can now be carried out at processor speed. Users of MP/M or CP/NET will find the benefits especially attractive.

ALL THIS FOR ONLY £295

Too good to be true? Seeing is believing.
Ask your dealer to demonstrate it
or contact Microcosm direct.

Dealer enquiries also welcome.

NEW

• Circle No. 123

HAPPINESS

is knowing you have spent
only **£259*** for your **Epson** printer

The MX70

* price excludes
VAT and
delivery
charges

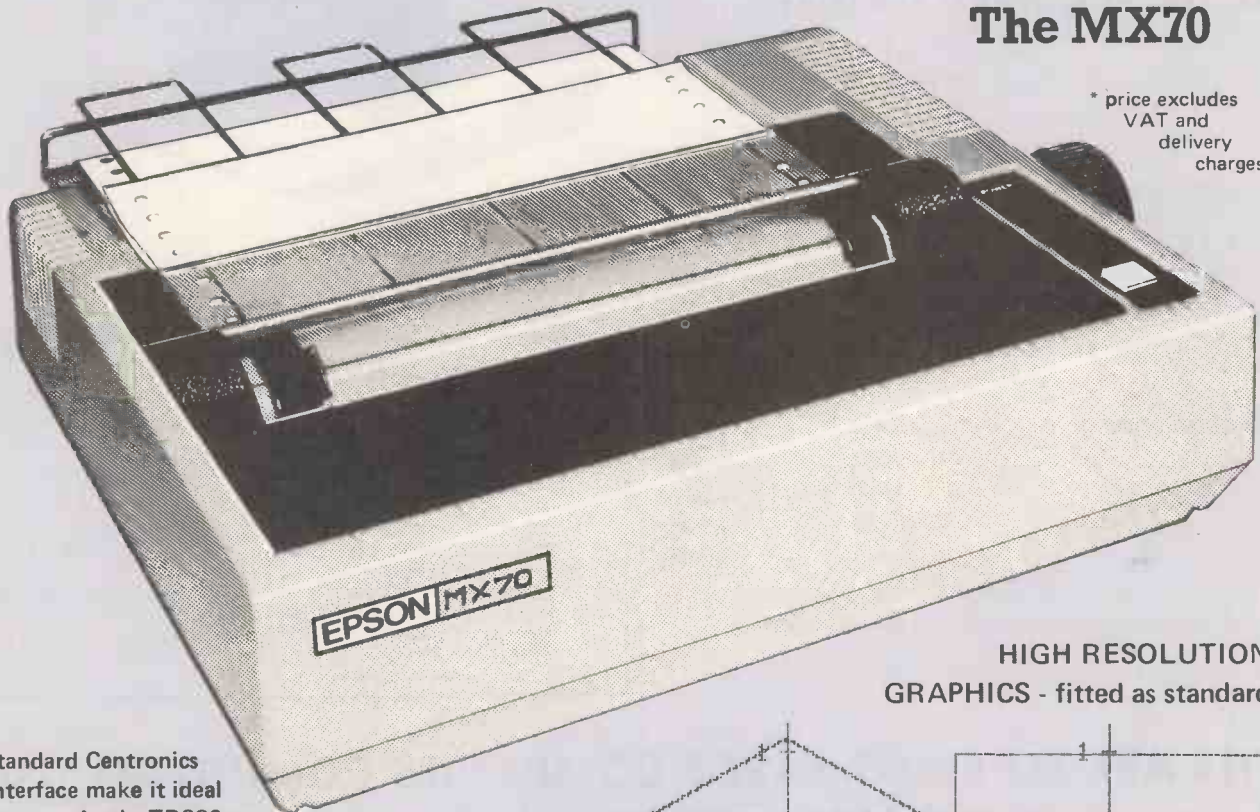

Standard Centronics
Interface make it ideal
for your Apple, TRS80 etc.

The MX70 comes with only a Centronics Interface, yet it offers **HIGH RESOLUTION GRAPHICS** and has a speed of 80 cps !!! We certainly believe we can claim the MX70 is the **WORLD'S LOWEST COST 9½" TRACTOR PRINTER**.

And with the name EPSON on it — a subsidiary of the SEIKO WATCH CO of Japan — you can rest assured of its reliability and quality.

*80 cps *Uni-directional *Easy to read 5x7 dot matrix
*High Resolution Graphics (480x8 dots) *Enlarged Printing
*4 National Character Sets *Optional Interface - TRS80,
Apple II Plus, Nascom *Top of Form *Self Test *£ sign
*Programmable Line Feed *Backspace

HIGH RESOLUTION GRAPHICS - fitted as standard

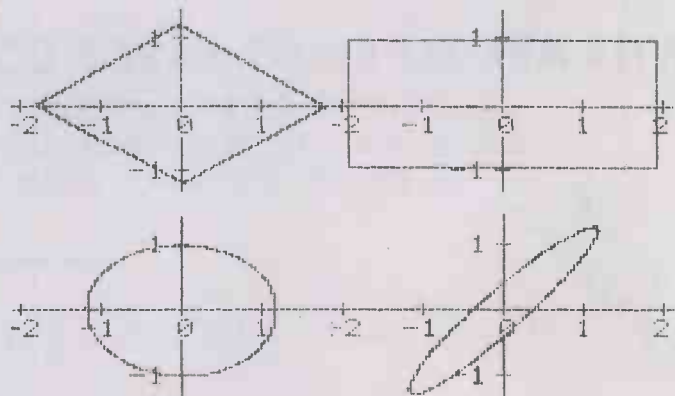

HIGH RES PRINTOUT WITH MX70 & APPLE

THE EPSON DISTRIBUTOR

Micro Peripherals

61 New Market Square,
Basingstoke, Hampshire RG21 1HW

Tel: 0256 56468 (4 lines) Tlx: 858575

Ring lan for up to the minute prices and
technical information on a whole range of
Japanese Micro Products

To: Micro Peripherals, 61 New Market Square, Basingstoke, Hants.

Please send me full details of the EPSON range including printout.

Name..... Position:.....

Company:.....

Address:.....

..... PC5A
(BLOCK CAPITALS PLEASE)

• Circle No. 124

SUPERBRAIN™ PLUS

INTERTEC DATA SYSTEMS* INTRODUCED
THE REMARKABLE SUPERBRAIN AT THE
START OF 1980

now ENCOTEL SYSTEMS LTD.
introduces SUPERBRAIN +

ALL THE STANDARD FEATURES

- * 64K RAM * DUAL Z80 A's *
- * DUAL RS-232 COMMUNICATIONS PORTS*
- * CP/M 2.2 OPERATING SYSTEM *

- + 800K DISC CAPACITY STANDARD (STD QD M/C 700K)
- + 1.5 MB OPTIONAL
- + FAST DISC ACCESS — FIVE TIMES FASTER THAN STANDARD MACHINES
- + KEY REPEAT
- + OPTIONAL TELEX BOARD



SUPERBRAIN +	800K	£2450
	1500K	£2800
* HARD DISCS	10MB	£2640
	32MB	£7900
	96MB	£9900

* (allows up to 255 COMPUSTAR users)

6 month warranty — 1 years maintenance agreement £200

** SOFTWARE **

THE BEST RANGE OF SOFTWARE

new

- * 6502/6800/8080/8085/Z80 ASSEMBLER
- * 8048 ASSEMBLER
- * THE CREATOR BASIC PROGRAM WRITER
- * THE REPORTER BASIC FILE REPORTER
- * SPELLBINDER WORD PROCESSING
- * Demonstrable IBM 3780 EMULATOR (3270 soon)
- * A DBMS WHICH SURPASSES CODASYL DBMS REQUIREMENTS
- * GRAHAM DORIAN BUSINESS SOFTWARE
- * BASIC, COBOL, FORTRAN, PL/I, PASCAL (APL soon)
- * DATA ENTRY SYSTEM AND DATA ENTRY TOOL £75 EACH
- * ASYNC TERMINAL SOFTWARE £75

WHY ARE SO MANY LARGE COMPANIES COMING TO US?

*because WE OFFER fast DELIVERY, PROFESSIONAL SERVICE
IBM COMMUNICATIONS EMULATORS, SOUND ENGINEERING AND
SOFTWARE EXPERIENCE, COMPETITIVE PRICES and backup*

Remember
SUPERBRAIN +

IS ONLY AVAILABLE FROM THE ENCOTEL DEALER GROUP

TERODEC MICROSYSTEMS LTD
BOYD MICROSYSTEMS LTD
MAP COMPUTERS LTD
MAP COMPUTERS LTD
MAP COMPUTERS LTD
DIALOGUE TERMINALS LTD
SYSTEMS MICROS LTD
MICROMANAGEMENT LTD
REBYALE COMPUTERS LTD
OCEANIC LTD

Reading, Berks
Bushey Heath, Herts
Oldham, Lancs
Leeds
Glasgow
London
Telford, Staffs
Ipswich, Suffolk
Bury St Edmonds, Suffolk
London

(0734) 664345/6
(01) 950 0303
(061) 633 3084
(0532) 445234
(041) 204 1297
(01) 660 0119
(0952) 460 214
(0473) 4592
(095381) 316
(01) 488 9751

WORKFLOW LTD
D D M LTD
ENSIGN LTD
KING PIN COMPUTERS LTD
ISIS COMPUTER SERVICES
NICOMTECH LTD
ORCHARD MICROBYTE LTD
BUSINESS CONTROL & DEVELOPMENT
LABTRONICS COMPUTERS LTD
J.R. INSTRUMENTS

Cowden, Kent
Brentwood, Essex
Swindon, Wiltshire
Stevenage, Herts
Henley on Thames, Oxon
Plymouth, Devon
Rayleigh, Essex
Cheltenham, Glos
London & Kent
Sanderstead, Surrey

(034286) 357
(0277) 214168 or 229379
(0793) 42615
(0438) 59677
(04912) 77735
(0752) 669801
(0268) 741271
Evesham (0386) 831969
(09592) 2872
(01) 657 7646



Encotel Systems Ltd

530 - 539 Purley Way, Croydon, Surrey

Telephone: 01-686 9687/8

Telex 265605

* WE ARE OFFICAL INTERTEC DISTRIBUTORS *

• Circle No. 125



BLACK WHITE OR GREEN THE CHOICE IS YOURS.

Black & White model £85.00 + VAT + £4.50 car.

Green model £95.00 + VAT + £4.50 car.

OVM Video Monitors:—

Precision engineered Video Monitors, with a 9" screen, accepting standard 1.4V P-P inputs at 75 ohms or high impedance.

Metal cased, solid state and reliable, white or green.

The choice is yours.

LOWE ELECTRONICS

CHESTERFIELD ROAD, MATLOCK, DERBYSHIRE DE4 5LE TEL 0629 4995.

TRADE ENQUIRIES WELCOME



• Circle No. 126

Da Vinci Computer Shop

65, High Street, Edgware, Middx HA8 7DD.

Open

Mon-Fri 9-5.30

Sat 9.30-5.30



Tel 01-952 0526

NEW PRICE PETS
 CBM 32K £695.00
 CBM 3040 FLOPPY £695.00
 CBM 3022 PRINTER £425.00

**SALES/PURCHASE -
 LEDGER ACCOUNTING
 INCOMPLETE RECORDS**

**NEW 80 COLUMN
 SCREEN PET
 £895.00**

**NEW 1 MEG. DISC
 DRIVE £895.00**

**WORDS PROCESSING
 INVOICING - PAYROLL.**

**STOCK CONTROL
 INFORMATION RETRIEVAL**

**ODJME SPRINTS
 DAISY PRINTER
 £2115.00**

Da Vinci Computer Shop

OUR SYSTEMS ARE MASTERPIECES - COME AND SEE THEM!

• Circle No. 127

EMG MICRO SYSTEMS EMG 01-688 0088

We are specialists in complete installations tailor made for your business requirements:

WORD PROCESSING SYSTEM	£1999
INVOICE AND CUSTOMER SYSTEM	£2999
LEADS AND SALES SYSTEM	£2999
INSURANCE AGENT SYSTEM	£2999
ESTATE AGENCY SYSTEM	£2999
COMPLETE BUSINESS SYSTEM	£3999

We are MAIN LONDON SORCERER STOCKISTS

Sorcerer Systems Desk, Mains Stabilisation, Cooling Fan, Memory Upgrades, Servicing

	RENTAL
Plug-in 315K Disk Drive	£4.31 per week
Video Disk Unit	£ 5.59 per week
Daisywheel WP System	£14.99 per week
WP Correspondence Course, Link your Sorcerer to a mainfram or other Sorcerer	

Full software list on request

6 COPIES OF SOURCE MAGAZINE ONLY £5

Write to Dept PCA, EMG Microcomputers Ltd, 30, Heathfield Road, Croydon, Surrey.

Circle No. 128

NASBUS NEWS

COMPATIBLE

More great deals from 6 Nascom Dealers

A NASCOM-2 BASED SYSTEM FOR £1549 + VAT

The proven Nascom-2 microcomputer can now be bought as a complete system for £1499 + VAT. For this price you get the Nascom-2 kit, 16K RAM board kit, Kenilworth case with 2 card frame, Centronics 737 printer, 10 inch monitor, and the

Gemini Dual Drive Floppy Disk System. The CPU and RAM boards are also available built – the additional cost is available on application.

GEMINI G805 FLOPPY DISK SYSTEM FOR NASCOM-1 & 2

It's here at last. A floppy disk system and CP/M.

CP/M SYSTEM. The disk unit comes fully assembled complete with one or two 5 $\frac{1}{4}$ " drives (FD250 double sided, single density) giving 160K per drive, controller card, power supply, interconnects from Nascom-1 or 2 to the FDC card and a second interconnect from the FDC card to two drives, CP/M 1.4 on diskette plus manual, a BIOS EPROM and new N2MD PROM. All in a stylish enclosure.

Nascom-2 Single drive system. **£450 + VAT**
 Nascom-2 Double drive system **£640 + VAT**
 Nascom-1 Single drive system. **£460 + VAT**
 Nascom-1 Double drive system **£650 + VAT**
 Additional FD250 drives **£205 + VAT**

D-DOS SYSTEM. The disk unit is also available without CP/M to enable existing Nas-Sys software to be used. Simple read, write routines are supplied in EPROM. The unit plugs straight into the Nascom PIO.

Single drive system **£395 + VAT**
 (please state which Nascom the unit is for)
 Certain parts of the CP/M and D-DOS disk systems are available in kit form. Details available on request.

KENILWORTH CASE FOR NASCOM-2

The Kenilworth case is a professional case designed specifically for the Nascom-2 and up to four additional 8" x 8" cards. It has hardwood side panels and a plastic coated steel base and cover. A fully cut back panel will accept a fan, UHF and video connectors and up to 8 D-type connectors. The basic case accepts the N2 board, PSU and keyboard. Optional support kits are available for 2 and 5 card expansion.

Kenilworth case **£49.50 + VAT**
 2-card support kit **£7.50 + VAT**
 5-card support kit **£19.50 + VAT**

GEMINI EPROM BOARD

This Nasbus compatible EPROM board accepts up to 16, 2716 or 2708 EPROMs. It has a separate socket for the MK36271 8K BASIC ROM for the benefit of Nascom-1 users. And for Nascom-2 users, a wait state for slower EPROMs. The board also supports the Nascom Page Mode Scheme.

EPROM Board (kit) **£55 + VAT**
 EPROM Board (built & tested) **£70 + VAT**



CASSETTE ENHANCING UNIT

The Castle interface is a built and tested add-on unit which lifts the Nascom-2 into the class of the fully professional computer. It mutes spurious output from cassette recorder switching, adds motor control facilities, automatically switches output between cassette and printer, simplifies 2400 baud cassette operating and provides true RS232 handshake.

Castle Interface Unit **£17.50 + VAT**

A-D CONVERTER

For really interesting and useful interactions with the 'outside world' the Milham analogue to digital converter is a must. This 8-bit converter is multiplexed between four channels – all software selectable. Sampling rate is 4KHz. Sensitivity is adjustable. Typical applications include temperature measurement, voice analysis, joystick tracking and voltage measurement. It is supplied built and tested with extensive software and easy connection to the Nascom PIO.

Milham A-D Converter (built and tested) **£49.50 + VAT**

PROGRAMMER'S AID

For Nascom ROM BASIC running under Nas-Sys. Supplied in 2 x 2708 EPROMs. Features include: auto line numbering; intelligent renumbering; program appending; line deletion; hexadecimal conversion; recompression of reserved words; auto repeat; and printer handshake routines. When ordering please state whether this is to be used with Nas-Sys 1 or 3. **Price £28 + VAT.**

DUAL MONITOR BOARD

A piggy-back board that allows N1 users to switch rapidly between two separate operating systems. **Price (kit) £6.50 + VAT.**

NASCOM-2 Microcomputer Kit **£225 + VAT**
 NASCOM-1 Microcomputer Kit **£125 + VAT**
 Built & tested **£140 + VAT**
 IMP Printer. Built & tested **£325 + VAT**

CENTRONICS 737 MICRO PRINTER

A high performance, low price, dot-matrix printer that runs at 80cps (proportional) and 50cps (monospaced). This new printer gives text processing quality print. And can print subscripts and superscripts. It has 3-way paper handling and parallel interface as standard. Serial interface is optional. **Price £425 + VAT.** Fanfold paper (2000 sheets) **£18 + VAT.**

GEMINI 'SUPERMUM'

12 x 8 piggy-back board for Nascom-1 offering five-slot motherboard, quality 5A power supply and reliable buffering with reset jump facility. **Price £85 + VAT.**

BITS & PC's PCG

5 x 4 board which plugs straight into Nascom-2. Operates on cell structure of 128 dots, producing 64 different cells. Once defined, each cell may be placed anywhere, any number of times on screen simultaneously. Max screen capacity: 768 cells. Dot resolution: 384 x 256 = 98304. Many other features including intermixing of alpha-numeric characters and pixels. **Price (kit) £60 + VAT.**

GEMINI 64K RAM BOARD

Newly developed Nasbus compatible board that can accommodate up to 64K of RAM including Page Mode facility. **Prices: £110 (16K), £130 (32K), £150 (48K), £170 (64K).** Add VAT to all prices.

All prices are correct at time of going to press and are effective 1st May 1981.

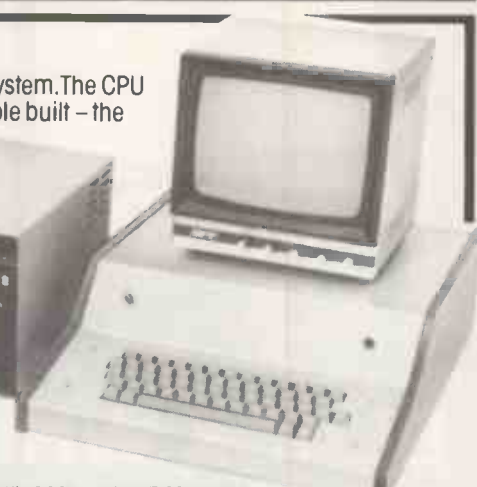

DISKPEN

The powerful text editor written for the Nascom is now available on a 5 $\frac{1}{4}$ inch floppy disk with a number of new features. **Price £43.25 + VAT.**

PORT PROBE

Allows monitoring of input and output of Nascom PIO. This board can generate interrupts and simulate handshake control. **Price (kit) £17.50 + VAT.**

HEX & CONTROL KEYPADS

Hexadecimal scratchpad keyboard kit for N1/2. **Price £34 + VAT.** As above but including (on the same board) a control keypad kit to add N2 control keys to N1. **Price £40.50 + VAT.**

BASIC PROGRAMMER'S AID

Supplied on tape for N1/2 running Nas-Sys and Nascom ROM BASIC. Features include auto line number, full cross-reference listing, delete lines, find, compacting command, plus a comprehensive line re-numbering facility. **Price £13 + VAT.**

GEMINI EPROM-PROG.

2708 (multi-rail) and 2716 (single-rail) EPROM programmer kit controlled by N1/2 PIO. Supplied with comprehensive software for use with Nas-Sys. **Price £35.95 + VAT.**



All the products are available while stocks last from the Nascom dealers below. (Mail order enquirers should telephone for delivery dates and post and packing costs.) Access & Barclaycard welcome.

BITS & PC'S
 4, Westgate, Wetherby, W. Yorks.
 Tel: (0937) 63774.

BUSINESS & LEISURE MICROCOMPUTERS
 16 The Square, Kenilworth, Warks.
 Tel: (0926) 512127.

ELECTROVALUE LTD.
 680 Burnage Lane, Burnage,
 Manchester M19 1NA.
 Tel: (061) 432 4945.
 28 St Judes, Englefield Green,
 Egham, Surrey TW20 0HB.
 Tel: (0784) 33603. Tlx: 264475.

TARGET ELECTRONICS
 16 Cherry Lane, Bristol BS1 3NG.
 Tel: (0272) 421196.

INTERFACE COMPONENTS LTD.
 Oakfield Comer, Sycamore Road,
 Amersham, Bucks.
 Tel: (02403) 22307. Tlx: 837788.

HENRY'S RADIO
 404 Edgware Road, London W2.
 Tel: (01) 402 6822.
 Tlx: 262284 (quote ref: 1400).



• Circle No. 129

Discover the full professional power of Hewlett-Packard's personal computer.

Now you can extend the HP-85's power simply by plugging in high-performance printers, plotters and flexible disc systems.

Power where you need it.

The HP-85 puts professional problem-solving power wherever you need it. There's a video display with high resolution and editing capability. A whisper-quiet thermal printer for hard copies of display graphics and alphanumerics. A magnetic tape unit with up to 217 K of storage per cartridge. And a complete keyboard, including eight keys you can define yourself. Powerful, easy-to-use features, thanks to HP's extended BASIC programming language.

Decide the peripherals you need.

HP's Interface Bus (HP-IB/IEEE-488) lets you add up to 14 peripherals or instruments. No need to write special operating programs—HP's peripheral ROMs do it for you.

New HP enhancement ROMs and modules give you access to 80 K bytes of operating system, without significantly reducing user memory. The HP 2631B printer means high-speed, high-quality printing. And the HP 7225 Graphics Plotter gives you high-resolution, publication-quality graphics on paper or film.

For extra memory storage, use the HP 82900 series of 5¼" flexible disc drives. Each drive gives you about 270 K bytes of formatted storage on double-sided, double-density discs. The operating system is in the Mass Storage ROM, leaving the HP-85 main memory free.

Behind the HP-85 computing system is the strength of Hewlett-Packard. Continuous commitment to quality. One-source service and support.

Contact your nearest dealer for a demonstration. Aberdeen Tyseal Typewriter Services, Tel: 29019; Belfast Cardiac Services, Tel: 625566; Birmingham Anglo American Computing, Tel: 65396; Colleshill 65396; Taylor Wilson Systems, Tel: Knowle 6192; Bournemouth South Coast Business Machines, Tel: Wimborne 893040; Brighton Office Machinery Engineering, Tel: 689682; Bristol Decimal Business Machines, Tel: 294591; Cambridge Cambridge Computer Store, Tel: 65334; Chelmsford Automatic & Electronic Calculators, Tel: 69529; Dublin Abacus Systems, Tel: 711966; Edinburgh Business & Electronic Machines, Tel: 226 4294; Holdene, Tel: 668 2727; Glasgow Robox, Tel: 221 5401; Leeds Holdene, Tel: 459459; Leicester Sumlock Services, Tel: 29673; Liverpool Rockliff Brothers, Tel: 521 5830; London Automatic & Electronic Calculators, Tel: 247 1886; Euro Calc, Tels: 739 6484, 636 8161, 405 3113; Sumlock-Bondain, Tels: 250 0505, 626 0487; The Xerox Store, Tel: 629 0694; Manchester Automated Business Equipment, Tel: 432 0708; Holdene, Tel: Wilmslow 529486; Newcastle Thos Hill Group, Tel: 739261; Newport Micromedia Systems Ltd, Tel: 59276; Reading CSE Computers, Tel: 61492; Sintrom Electronics, Tel: 85464; Royston (Herts) Electroplan, Tel: 41171; Southampton South Coast Business Machines, Tel: 22958; Sunderland Thos Hill Group, Tel: 42447; Tunbridge Wells DJ Herriott, Tel: 22443/4; Wallingford Midas Advisory Services, Tel: 36773; Watford Automatic & Electronic Calculators, Tel: 31571; Woking Petallect Electronic Services Ltd, Tel: 69032; Worthing Office Machinery Engineering, Tel: 207292; Channel Islands: (Guernsey) Professional Business Systems, Tel: 26011, (Jersey) Professional Business Systems, Tel: 75611.



For more details or a demonstration, contact your nearest HP Dealer shown below.



**HEWLETT
PACKARD**

• Circle No. 130



TUSCAN BASED COMPUTER SYSTEMS

- WE — SUPPLY** SYSTEMS FOR BUSINESS APPLICATIONS USING THE "TUSCAN" S100 CP/M* MICRO-COMPUTER WITH 5¼" OR 8" DISCS.
- WE — ADVISE** AND CAN WRITE ANY SOFTWARE PACKAGES FOR OUR SYSTEMS.
- WE — ALSO PROVIDE** STANDARD SOFTWARE FOR ESTATE AGENTS, INSURANCE AGENTS, BUSINESS ACCOUNTING AND WORD PROCESSING.
- WE — INCLUDE** IN OUR PRICES THE DELIVERY, TESTING AND COMMISSIONING AT YOUR PREMISES OF COMPLETE SYSTEMS FOR 7 DAYS.
THEREFORE WE CAN ONLY GIVE THIS SERVICE WITHIN 50 MILES OF NEWBURY.
- WE — CAN DELIVER** HARDWARE, SUCH AS TUSCAN IN ASSEMBLED FORM TOGETHER WITH DISC DRIVES ETC. TO ANY AREA.

FOR FURTHER INFORMATION PHONE OR WRITE, GIVING DETAILS OF YOUR APPLICATION.

PURLEY COMPUTER SYSTEMS LTD.

21 BARTHOLOMEW STREET,
NEWBURY, BERKS.
TEL: 0635 41784

*Reg. trademark.



• Circle No. 131

KEMITRON ELECTRONICS LTD

The Complete Business System

The KEMITRON K3000 Disk Based System is an all BRITISH microcomputer suitable for all Business and Educational applications. The basic unit consists of two 8" floppy disk drives, processor (Z80A), RAM, communications interface and supporting hardware.

Its unique modular design allows the simple addition of more memory or input/output interfaces as and when required. This powerful facility can also be applied to the addition of extra disks (up to four).

The computer is supported by the CP/M disk operating system which provides all communication between the disks, terminal and printer and includes several utility programs. CP/M is the industry standard and as such can utilise a wide variety of well supported software which is both readily available and reasonably priced.

APPLICATIONS

- * WORD PROCESSING
- * FINANCIAL PACKAGES
- * STOCK CONTROL
- * INVOICING
- * PAYROLL
- * ASSEMBLY LANGUAGE DEVELOPMENT
- * EDUCATIONAL & LABORATORY COMPUTER
- * PROGRAM DEVELOPMENT

TECHNICAL DETAILS

- * Z80A Based — runs at 4 MHz
- * 32-48 or 64K RAM — Dynamic
- * Twin RS232 ports — more if required
- * Twin 8" single sided single density disk drives
- * Supports CP/M

from £2,300 + VAT

**CHESTER
COMPUTING
CENTRE**

— Ring or write for further details

**21-23 CHARLES STREET
HOOLE, CHESTER CH2 3AY
TEL: (0244) 21817**

• Circle No. 132

WE'RE MAKING AN OFFER YOU CAN'T REFUSE

HARDWARE	
Apple 16K	695.00
Disk Drives	299.00
Controller 3.3	84.00
16K Add-on RAM	56.00
Full Colour System	435.00
9" High Res B/W Monitor	148.00
9" Black/White Monitor	127.00
12" Black/White Monitor	189.00
Cable for Monitor	9.00
12" Green/Black Cable	166.00

ACCESSORIES	
Speech Lab	122.00
Speechlink 2000	168.00
Pascal Language	299.00
Applesoft Card	116.00
Integer Card	116.00
80 Col Card	162.00
Apple Juice	157.00
Black/White Modulator	14.00
Clock/Calendar Card	168.00
Supertalker	179.00
Rom-Plus Board	127.89
Romwriter	106.00
Copyplus Rom	30.00
Music System - Complete	312.00
Apple Pilot	104.00

INTERFACE CARDS	
Prototype Cards	15.00
Parallel Printer Card	104.00
Comms Card	130.00
Serial Card	113.00
Centronics Card	130.00
Controller Card	45.00
Eurocolour Card	113.00
IEEE Interface	212.00

BUSINESS SOFTWARE	
Visicalc	125.00
Desk Top Plan	75.00
CCA Database	75.00
DMBS Database	100.00
Information Master	100.00
Data Master	100.00
Stock Systems from	100.00
Integrated Ledgers	855.00
Invoicer	140.00
Payroll	375.00
Word Processing from	42.00
Apple Post	27.00
Mailing List	70.00

MISCELLANEOUS	
DOS Tool Kit 3.3	42.00
Animation Pack	42.00
Versewriter	149.00
Graphics Tablet	462.00
Joy Stick	44.00
Revolving Tables	42.00



GAMES. THIS MONTH'S SPECIAL 48K APPLE FOR £695.00

WAR	
Bismark	29.95
Ambush	29.95
Napoleonics	29.95
Conflict	29.00
Air Combat	22.00
Galactic Trader	22.00
Galactic Revolution	22.00
Galactic Empire	22.00
Flight Simulator	
Cassette or Disk	29.95

OTHER	
Monopoly	12.00
Olympic Decathlon	20.00
Apple Bowl	9.00
Tranquility Base	20.00
Trilogy	26.00
Head-On (Car racing)	22.00
Typing Tutor (Cassette)	14.00
Gammon Gambler	15.00
Bridge Partner	14.00
Baseball	16.00
Sargon Chess	30.00
Animation Package	44.00

ADVENTURE	
Invasion Orion	18.00
Star Fleet Orion	18.00
Temple of Apsah	22.95
Apple Invaders	12.00
Moorlocks Tower	18.00
Adventure	24.00
Asteroids in Space	15.00
Akalabeth	24.00
Hell Fire Warrior	22.95
Datstones of Ryn	18.00

SHOOTING	
Wild Western Gunfighter	16.00
Battleship Commander	16.00
Bill Budge Space Album	34.00
Super Star Base Gunner	18.00
Super Space Invaders	22.00
Star Cruiser	22.00
Bloody Murder (Knife Throwing)	14.00
Hyper Space War	23.00

P.D.S. ROAD SHOW

P.D.S. will shortly be launching their 1981 road show in the North West. On exhibition will be micro and mini computers, with word and data processing capabilities, memory typewriters and plain paper copiers. Please phone for invitation card. Forthcoming venues April 16th Crest Suite, Crest Hotel, Bolton, 6th May Buckingham Room, Saxon Inn, Blackburn 9.30am-8pm.

IMPORTANT NOTICE

Continuing their competitive policy P.D.S. are now offering short and long term rentals for clients in the North West. Ring for details. Our Mail Order dept. is now open to service all the U.K. If you know your requirements ring for our price.

**SUBSTANTIAL DISCOUNTS FOR CASH PURCHASERS
WE NOW OFFER ONE FULL YEARS WARRANTY ON ALL APPLE EQUIPMENT**

Professional Data Systems.

CARNE HOUSE, MARKLAND HILL, CHORLEY NEW RD, BOLTON.

ALL PRICES CORRECT AT THE TIME OF GOING TO PRESS
(ALL PRICES SUBJECT TO VAT)



0204
493816



• Circle No. 133



Pete & Pam Computers

Microcomputer hardware & software
Specialists in Applefare
Peter & Pam Fisher

WE DISTRIBUTE FOR MICROSOFT, HIGH TECHNOLOGY, STONEWARE COMPUTER STATION, CALIFORNIA PACIFIC, DAKINS, BRODERBUND, STARCRAFT, SUB LOGIC AND MIR ENTERPRISES. DEALER ENQUIRIES WELCOMED.

APPLE — 16K EXPANSION BOARDS

At last — Apple users can obtain additional memory without the expense of buying a language system. Fully compatible with PASCAL, Integer BASIC as well as Microsoft SOFTCARD. VISICALC owners can also use additional memory.

Microsoft Ramcard £109.95

Andromeda Expansion Board £109.95

(can be changed to allow use of more than one board)

Z-80 SOFTCARD — £169

A Z-80A Microprocessor for Apple. Provides CP/M and MBASIC-5. Allows use of **COBOL 80 — £299.**

FORTRAN 80 — £109.95 — Basic Complete £195

NEW Wordstar, the Prince of Wordprocessors, on APPLE formatted CP/M disc — £250.

THE MILL 6809 BOARD — £169

A 6809 processor for APPLE Allows joint use of 6502 and 6809 processors.

Coming soon — PASCAL, Patcher — to double the speed of APPLES UCSD Pascal.

VISICALC — £75

A must for every APPLE owner — soon to be enhanced by being linked to INFORMATION MASTER CCA DATAM Management system **£49.95**

80 Column Boards

Sup-R-Terminal — £195

Videx — £179

Apple Pie 80 Column Word Processor for above — £75

PLEASE ADD 15% VAT TO YOUR ORDER
POSTAGE AND PACKING FREE
ASK FOR OUR FULL CATALOG
IF YOU KNOW WHAT YOU WANT AND DON'T WANT TO PAY
AN INFLATED PRICE
GIVE US A CALL — WE SELL ALL SORTS OF THINGS FOR APPLE
TEL: 01-877 2062 (24HRS) 7 DAYS A WEEK
98 MOYSER ROAD LONDON SW16 6SH
POST OFFICE GIRO NO. 585 6450

• Circle No. 134

UNIVERSITY OF MANCHESTER EXTRA-MURAL DEPARTMENT

Learn Basic Practical Basic

A residential course, Sunday evening, 2nd August to Friday afternoon, 7th August, 1981, at Holly Royde, Manchester.

All computers use a high level language. Most microcomputers off BASIC as a standard high level language. Anyone can learn BASIC!

This is for those with no previous experience of BASIC and probably no programming experience. The whole emphasis of the course will be a leisured approach to the writing of well structured programs and the teaching will be as practical as possible.

The fee will be £125 which includes full board and tuition.

Advanced Programming for the PET

A residential course, Saturday morning, 19th September to Sunday afternoon 20th September, 1981, at Holly Royde, Manchester.

A two-day intensive course suitable for people with previous programming experience and a knowledge of BASIC. It will cover writing faster programs — writing more efficient programs — introduction to machine code — communicating with peripheral devices — peeks and pokes.

The fee will be £70 which includes full board and tuition.

For full details of both the above courses please contact:

Mrs. Sue Eden

Department of Extra-Mural Studies,
The University, Manchester, M13 9PL,
or telephone 061-273 3333 ext 3076.

• Circle No. 135



FEATURES

- extremely fast editing
- includes a character-oriented, floating cursor edit with Add, Change, Math, Print and Preview modes.
- Single key cursor control
- Automatic word overflow
- Character, Word and Line Insertion
- Forward and Backward scrolling
- Automatic on screen tabbing
- Auto paragraph indent
- Character Word and Line deletion
- Block copy, save and delete
- Advanced file handling
- Global (multi-file) search and replace
- Column decimal alignment justification
- Automatic pagination
- printer tab controls
- Line Centering
- On-screen lower case with Data Shift Adapter (Paymar also supported)
- Split-Screen allows editing two portions of a file simultaneously
- built in 15 digit floating point calculator performs on-screen calculations, column totals and verifies numeric data in statistical documents.
- Maximum file size 20,049 characters.
- Automatic file linkage (Autolink) provides unlimited file size.
- Preview a file exactly as it would print. The preview mode carries Autolink operations allowing inspection of large documents. Uses any printer which will interface with an apple computer
- Printing features include; underline, bold face, superscript, subscript.

Complete Software with Full Documentation and Binder £145.00 Plus VAT) (Requires 48k Apple II or Apple II plus).

ADDRESS BOOK (Mailing List)

In our opinion, the BEST mailing list programme for apple! Stores 700 addresses per disk, select by record contents for viewing, label printing or may be used in conjunction with Super-Text II. (Requires 48K Apple II or Apple II plus) £49.95 + VAT.

DATA SHIFT (Lower case Adaptor)

This ROM simply plugs into your Apple to display upper and lower case characters on screen. Data Shift carries a full 96 Character ASCII set £35.75 + VAT.

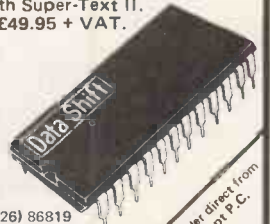

See these products at our stockists:

BARNSELY: Wharnccliffe Business Systems	Tel(0226) 86819
BRISTOL: Decimal Business Machine	Tel(0272) 214093
BRISTOL: Dataforce (UK) Ltd.	Tel(0272) 279016
CARDIFF: David Porter Office Equipment	Tel(0222) 496785
ST. HELENS: Page Electronic Developments	Tel(0744) 21030
WEST BROMWICH: H&H Business Systems	Tel(038-483)2363

In case of difficulty order direct from
C. A. CLIFF ROAD, Dept 7 C.
ASHTON GATE,
BRISTOL
BS3 1RZ.

• Circle No. 136



COMPUTER WAREHOUSE

NOW OPEN
MONDAY-SATURDAY
9.30-5.30

In stock now test equipment, microprocessors, teletypes, transformers, power supplies, scopes, sig. gen's, motors, peripheral equipment, I.C.'s, tools, components, variacs, keyboards, transistors, microswitches, V.D.U.'s sub-assemblies + thousands of other stock lines. Just a mere fraction of our vast range, is displayed below: 100's of bargains for callers.

RAM AND EPROM NEW LOW VAT INCLUSIVE PRICES

2716 5v Rail £9-50	4116 200 NS 16KX1 DYN. 8 for £19-95
2716 3 Rail £8-50	2134L-3 300 NS 1KX4 ST. 8 for £22-50
2708 450NS £4-50	2102L-3 650 NS 1KX1 ST. 8 for £ 5-50
2708 Ex Equip £2-25	TMS4030JL 300 NS 4KX1 DYN 8 for £ 9-95

All devices full spec. and guaranteed. Bulk enquiries welcome.

TELETYPE ASR33 I/O TERMINALS



From £195 + CAR + VAT

Fully fledged industry standard ASR33 data terminal. Many features including: ASCII keyboard and printer for data I/O, auto data detect circuitry, RS232 serial interface, 110 baud, 8 bit paper tape punch and reader for off line data preparation and ridiculously cheap and reliable data storage. Supplied in good condition and in working order. Options: Floor stand £12.50 + VAT
Sound proof enclosure £25.00 + VAT

ICL TERMIPRINTER 300 BAUD TERMINALS



PRICES REDUCED

ONLY £295

+ CAR + VAT

Made under licence from the world famous GE Co. The ICL Termiprinter is a small attractive unit with so many features it is impossible to list them in the space available! Brief spec. as follows: RS232 serial interface, switchable baud rates 110, 150, 300, (30 cps), upper and lower case correspondence type face, standard paper, almost silent running, form feed, electronic tab settings, suited for word processor applications plus many more features. Supplied in good condition and in working order. Limited quantity.

SCOOP PURCHASE 12" VIDEO MONITORS



CONNECT DIRECT TO YOUR MICRO

Made by the "BALL MIRATEL" CORPORATION USA the CD12 is a self contained, mains powered chassis professional monitor. All controls are inbuilt on a single PCB with exception of the brightness control which can be brought out for external use. Many features such as composite video, quoted bandwidth of 19 Mhz, superb linearity and definition make this a must for any MICRO/CCTV application. Brand new and boxed only + carriage £7.50 + VAT. £97.50 + VAT
Input harness, brightness pot and connector £2.50 + VAT. Dimensions 9"H x 11"D x 11 1/2"W

HURRY WHILE STOCKS LAST

EX STOCK SOFTY

EPROM BLOWER
Software development system invaluable tool for designers, hobbyists, etc. Enables open heart surgery on 2716, 2708 etc. Blows, copies, reads EPROMS or emulates EPROM/ROM/RAM in situ whilst displaying contents on domestic TV receiver. Many other features. £115 + carr. + VAT. Optional 2716 Function Card £40 + VAT. PSU £20 + £1.50 carr. + VAT.
Write or phone for more details.

3K x 8 STATIC RAM CARDS

BRAND NEW PCB organised as a 3K x 8 page memory with 24 socketed 2102-L 650ns Rams, 4 Eprom Sockets and 16 TTL Chips for decoding. All IC's guaranteed.
Complete with circuit only £24.50 + £1.75 P.P.
Dimensions 264 x 195mm. 0.1" connector.

EQUIPMENT CASES

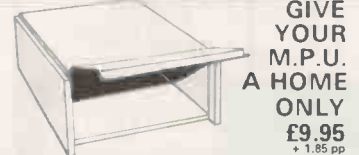

GIVE YOUR M.P.U. A HOME ONLY £9.95 + 1.85 pp

Superb professional fully enclosed, made for the G.P.O. to the highest standard, offered at a fraction of their original cost they feature aluminium sides, hinged removable front panel, which can be secured by 2 screws to prevent prying fingers. All are finished in two tone G.P.O. grey and although believed brand new may have minor scuff marks/scratches due to bad storage. Dimensions 16"D x 6 1/2"H x 14 3/4"W

NATIONAL MA1012 LED CLOCK MODULE

- ★ 12 HOUR
- ★ ALARM
- ★ 50/60 HZ

The same module as used in most ALARM/CLOCK radios today, the only difference is our price! All electronics are mounted on a PCB measuring only 3" x 1 1/4" and by addition of a few switches and 5/16 volts AC you have a multi function alarm clock at a fraction of cost. Other features include snooze timer, am pm, alarm set, power fail indicator; flashing seconds cursor, modulated alarm output etc. Supplied brand new with full data only Suitable transformer £1.75. £5.25

SEMICONDUCTOR 'GRAB BAGS'

Amazing value mixed semiconductors, include transistors, digital, linear I.C.'s, triacs, diodes, bridge recs. etc. etc. All devices guaranteed brand new, full spec. with manufacturers markings, fully guaranteed. 50 + BAG £2.95 100 + BAGS £5.15

MUFFIN FANS

Keep your equipment Cool and Reliable with our tested ex-equipment 'Muffin Fans' almost silent running and easily mounted. Available in two voltages. 110 V.A.C. £5.05 + pp 90p OR 240v A.C. £6.15 + pp 90p DIMENSIONS 4 1/2" x 4 1/2" x 1 1/2"

ELECTRONIC COMPONENTS & EQUIPMENT

66% DISCOUNT

Due to our massive bulk purchasing programme which enables us to bring you the best possible bargains, we have thousands of I.C.'s, Transistors, Relays, Cap's., P.C.B.'s, Sub-assemblies, Switches, etc. etc. surplus to our requirements. Because we don't have sufficient stocks of any one item to include in our ads., we are packing all these items into the "BARGAIN PARCEL OF A LIFETIME" Thousands of components at giveaway prices! Guaranteed to be worth at least 3 times what you pay plus we always include something from our ads. for unbeatable value!! Sold by weight

2.5kls £ 4.75 + pp £1.25	5kls £ 6.75 + pp £1.80
10kls £11.75 + pp £2.25	20kls £19.99 + pp £4.75

OP PRESS - STOP PRESS - STOP PRESS - STOP STEP INTO THE 80's

WITH TOMORROW'S WORLD TECHNOLOGY TODAY
The "TANTEL" Post Office approved
PRESTEL-VIEWDATA ADAPTOR

At last this amazing piece of micro technology is available at a price you can afford. Just connect to the aerial socket of any colour or black and white domestic TV receiver and to your Post Office installed jack socket and you are into the exciting world of PRESTEL. Via simple push button use you are able to view a staggering 170,000 pages of up to the minute information on many services and utilities, order goods from companies, even play games!! All this and more without ever leaving your armchair!

ONLY £170 + £1.75 carr + VAT Send £197.50p

Note: When ordering please give the address and telephone number where the Tantel adaptor is to be used, we will arrange all details with the Post Office for installation of the jack socket (normally within 7 days).

JUST IN

Secondhand chassis 9" Blue-best mains powered video monitors, composite video input with inbuilt 5v 3 amp DC P.S.U. Tested, but unguaranteed

£39.99 + £7.50 carriage
Complete with circuit.

MANUFACTURERS ONLY

100,000 EX STOCK Miniature relays continental series by Keyswitch, etc. all contact forms all impedances.

CALL FOR QUOTES

WE'VE BOUGHT ANOTHER SHIPMENT! SAVE OVER £1300!! DZM 180 CPS HIGH SPEED MATRIX PRINTERS

This must be one of our greatest bulk deals, this fabulous printer is listed at over £1800 and judging by the construction we are not surprised. Made under license from the LOGABAX Co. the DMZ180 is an exceptionally sturdy high speed 180 cps matrix printer, capable of printing up to 132 characters per line on standard "Fan Fold" sprocket fed paper. A precision 7 x 7 matrix head using ruby bearings, gives a clear concise type font. Many other features include internal buffer for high throughput, standard ink ribbon, software controllable form and tab functions, standard "CENTRONICS" ASCII parallel interface etc. etc.

Optional extras Floor Stand £30.00 + VAT, Paper Stand £18.00 + VAT

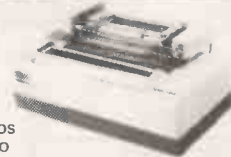

NOW ONLY £499 + Carr + VAT



Dept. PC. 64-66 Melfort Rd., Thornton Heath, Croydon, Surrey. Tel: 01-689 7702 or 01-689 6800

MAIL ORDER INFORMATION

Unless otherwise stated all prices inclusive of V.A.T. Cash with order. Minimum order value £2.00. Prices and Postage quoted for UK only. Where post and packing not indicated please add 60p per order. Bona Fida account orders minimum £10.00. Export and trade enquiries welcome. Orders despatched same day where possible. Access and Barclaycard Visa welcome.

MEMOREX/BASF 7 MB HARD DISK DRIVES

Model 630-1B disk drives by Memorex BASF, TTL signals in and out, high speed, IBM 2311 compatible. Sold in good condition but unguaranteed.

£175.00 + VAT
BUYERS COLLECT

"THE MULTIVOLT PSU"

The PSU to end all your MPU/LAB requirements, made by "Weir" Electronics at over £200.00. The supply features full regulation, current limit, and overvoltage protection on all 7 outputs, just look at the spec.

+5v @ 12 amps, +5v @ 4.5 amps, +5v @ 4 amps, +30v @ 2 amps, +12v @ 2.5 amps, -12v @ 2.5 amps and -9v @ 1 amp. A superb unit supplied in two grades, complete with data.

Brand New, Fully Tested £59.99
Used and Untested £39.99
Carriage and Insurance £7.50

RCA FULLY CASED ASCII CODED KEYBOARDS



Straight from the U.S.A. made by the world famous R.C.A. Co., the VP600 Series of cased freestanding keyboards meet all requirements of the most exacting user, right down to the price! Utilising the latest in switch technology, Guaranteed in excess of 5 million operations. The keyboard has a host of other features including full ASCII 128 character set, user definable keys, upper/lower case, rollover protection, single 5V rail, keyboard impervious to liquids and dust, TTL or CMOS outputs, even an on-board tone generator for keypress feedback, and a 1 year full R.C.A. backed guarantee.

VP601 7 bit fully coded output with delayed strobe, etc. £43.95
VP611 Same as VP601 with numeric pad. £54.95
VP606 Serial, RS232, 20MA and TTL output, with 6 selectable Baud Rates. £60.95
VP616 Same as VP606, with numeric pad, Post, Packing and Insurance. £72.50
£1.95

5v D.C. POWER SUPPLIES

Following the recent "SELL OUT" demand for our 5v 3 amp P.S.U. we have managed to secure a large quantity of ex-computer systems P.S.U.'s with the following spec.; 240 or 110v A.C. input. Outputs of 5v @ 3-4 amps, 7.2v @ 3 amps and 6.5v @ 1 amp. The 5v and 7.2v outputs are fully regulated and adjustable with variable current limiting on the 5v supply. Unit is self contained on a P.C.B. measuring only 12" x 5" x 3". The 7.2v output is ideal for feeding "on board" regulators or a further 3 amp LM323K regulator to give an effective 5v @ 7 amp supply. Supplied complete with circuit at only £10.95 + £1.75 pp. Believed working but untested, unguaranteed.

ELECTRONIC GAMES

ATARI

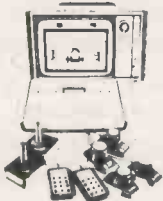

SPECIAL PRICE
£86 + VAT

SPACE INVADERS



HAND HELDS + CARTRIDGES
ATARI - ACETRONIC
PRINZTRONIC
RADOFIN - DATABASE etc.
We keep a full range!
Send for cartridge lists stating which machine you own.

INTELLIVISION MATTEL



£173.87 + VAT

Available August 1980
This is the most advanced TV game in the world.
Expandable next year into a full microcomputer.
COLOUR CATALOGUE AVAILABLE WITH DETAILS ON ALL THE CARTRIDGES

CHESS



Send for further details.

COMPUTERS

NEW RANGE AVAILABLE AUGUST 1980
We specialise in computer chess machines & stock over 13 different models from £20 to £300

TELETEXT



RADOFIN TELETEXT
Add on Adaptor
£199 + VAT

BRIDGE

COMPUTER



- * Plays 1/2/3 or 4 Hands
- * Problem Mode
- * Audio Feedback
- * Instant Response
- * Auto scorekeeping

BACKGAMMON

COMPUTERS

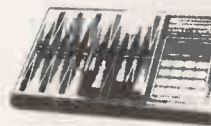

OMAR 1
OMAR 2
CHALLENGER
GAMMONMASTER

From £38 to £108. Send for further details.

DRAUGHTS

COMPUTER



- * Solves Problems
- * Rejects illegal moves
- 2 level machine £43 + VAT
- 4 level machine £77.78 + VAT

LEISURE

- * CHEAP TV GAMES
- * TELEPHONE ANSWERING MACHINES
- * AUTO DIALERS
- * CALCULATORS
- * DIGITAL WATCHES
- * PRESTEL
- * HAND HELD GAMES

27 TUNE DOOR BELL

£17.13 + VAT



FREE CATALOGUE

For a free copy of our 32 page catalogue, send a 12p stamp to Silica Shop Ltd or Telephone 01-301 1111

MAIL ORDER SERVICE — Free postage & Packing
TELEPHONE & MAIL ORDERS — accepted on:
Access * Barclaycard * American Express * Diners Club * Credit Facilities arranged
CALLERS WELCOME — at our shop in Sidcup — Demonstrations daily
Open from 9am-5.30pm mon-Sat (9am-1pm Thurs)
GUARANTEE — Full 12 months + After Sales Support

We have comprehensive brochures on all products. Please let us know what you are interested in and we will send you detailed brochures AND our own 32 page catalogue covering most games on the market.

SILICA SHOP

SILICA SHOP LTD.,
1/4 The Mews, Hatherley Rd., Sidcup
Kent DA14 4DX
Tel: 01 301 1111

• Circle No. 138

MicroStyle

9 St. Peters Terrace,
Lower Bristol Rd.
Bath, BA2 3BT.
Telex: 44371 (KEMP-G)

COMPUTERS

PET 8K	£415
PET 16K	£525
PET 32K	£650
PET 8032	£895
OHIO CI-P	£220
OHIO CI-E	£255
SUPERBOARD	£160
SUPERBOARD 'E'	£195
VIDEO GENIE	£330
SHARP MZ80K	£480
APPLE II	£695

SUPERBRAIN

SuperBrain's CP/M operating system boasts an overwhelming amount of available software in BASIC, FORTRAN, COBOL, and APL. Whatever your application... General Ledger, Accounts Receivable, Payroll, Inventory or Word Processing, SuperBrain is tops in its class.

320K £1850 700K £2400
1.5Mb £2750

DISC DRIVES

COMPU/THINK

400K	£795
800K	£995

COMMODORE

CBM 30/40	£695
-----------	------

ANOTHER FIRST FOR MICROSTYLE, THE

DAI PERSONAL COMPUTER

THE SECOND GENERATION PERSONAL COMPUTER

* HIGHEST PERFORMANCE * LOWEST PRICE

- * 48K (8080A)
- * 16 Colours or shades of Grey
- * Multiple High Resolution Graphics Modes (64 x 71, 129 x 159, 255 x 335)
- * Character mode (60 x 24)
- * Split Screen Modes
- * Full ASCII Upper & Lower Character Set
- * Unique graphical — Sound Commands for Smooth Music, random frequencies & enveloped sound!

* RS232 I/F



All as Standard

at only **£595 + VAT**

ACULAB FLOPPY TAPE

The ideal graduation from Cassettes for all TRS.80 and Video Genie owners

TRS.80 Version £165:

Video Genie £174

PRINTERS

EPSON TX80B (inc. I/F & cable)	£359
EPSON MX80	£425
ANADEX DP8000	£495
ANADEX DP9500	£895
ANADEX DP9501	£995
PAPER TIGER	£585
MICROLINE 80	£359
IBM GOLFBALL	£595
CENTRONICS 737	£425
NEXOS PETAL	£1195

VIDEO MONITORS

10" BLACK & WHITE	£85
10" GREEN SCREEN	£95

PLEASE ADD
.15% VAT
ON ALL PRICES

TEL: BATH (0225) 334659
AFTER HOURS (0761) 33283

• Circle No. 139

INTEGRATED SMALL BUSINESS SOFTWARE

ISBS

ISBS - F

A totally Integrated Small Business System designed for single user floppy disk based systems. ISBS-F is already being used by many Businesses and Professions throughout the UK. Each package can be used as standalone or can be built into an integrated system depending on user requirements. All packages are fully supported and maintained, and are supplied with easy to follow Reference Manuals. ISBS-F is easy to install and ideal for the first time small Business user with no previous computer experience.

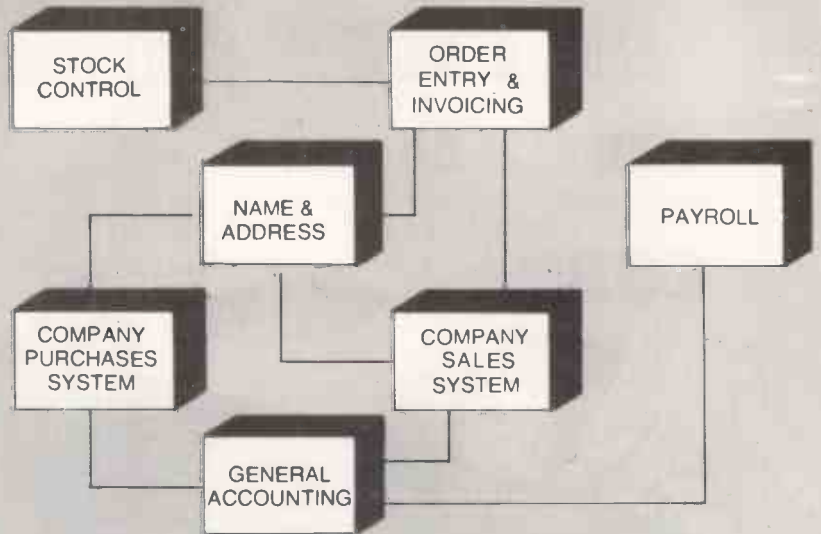

ISBS - W

A Hard disk or Winchester disk based Integrated Business Software system which is upwards compatible with ISBS-F. This system is ideal for the small to medium size user where data storage and processing speed exceeds the capabilities of floppy disk based systems. Choose from any combination of modules and add others at a later stage if required. The system features many facilities found in minicomputer and mainframe business packages. All modules are fully supported and maintained and comprehensive documentation is supplied with each installation.

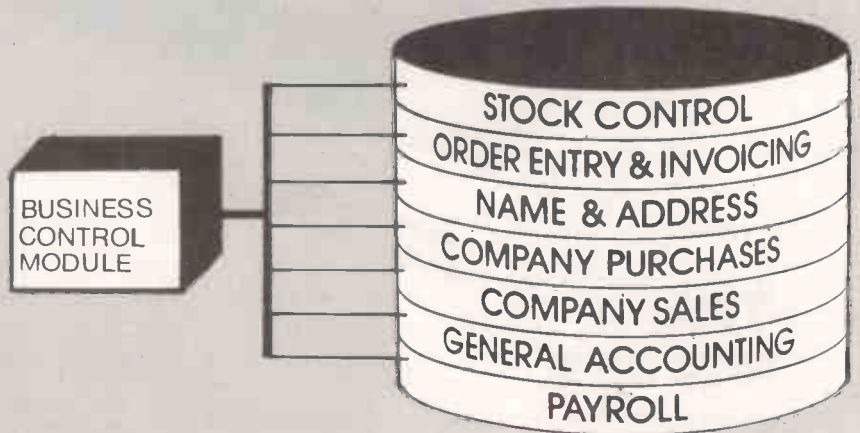

SYSTEM REQUIREMENTS

ISBS has been designed for most popular 8080/Z80 Microcomputer disk systems running under CP/M*

ISBS-F: 48k & 2 floppy disk system, VDU, 132 col printer, CP/M* 1.4 or 2.x

ISBS-W: 64k & Hard disk(s) system, VDU, 132 col printer CP/M* 2.x or MP/M*

Current installations on Rair Black Box, Northstar, Heath, Cromemco, Altos, Superbrain, IMS 5000/8000, Dynabyte, Micromation.

For further details and prices contact your nearest dealer or call us direct.

*CP/M, MP/M trademarks Digital Research.

GRAFFCOM
SYSTEMS GROUP

52 Shaftesbury Avenue London W1 01-734 5970

If this ad. doesn't convince you that **Epson** produce the **worlds' best** low cost quality printers...

- the **FREE** printout samples will!!

THE MX 80 FT/1

- both single sheet (friction) and continuous (tractor) feed & 9 wire head with true descenders

£399 + VAT

THE MX 80 FT/2

- as MX80 FT/1 and with HIGH RESOLUTION GRAPHICS

£449 + VAT



THE MX 82 T

- The Apple II Printer !!
9 x 9 matrix + Tractor Feed
+High Resolution Graphics

£415 + VAT

Ideal for
PET, Apple,
Sharp, TRS80, Video
Geni, RM 380Z, Nascom,
Superbrain and most Micro's

MX80 Features include:

- *True Descenders - 9 x 9 dot matrix for sharp legibility.
- *Emphasised and Double Characters - solid characters, a real must for word processing.
- *Dual Paper Handling - ideal for long print runs or single sheets with up to 3 copies.
- *Systems Flexibility - full range of optional interfaces and graphics ROM's.
- *International Versatility - internally selectable characters UK, USA, French and German.
- *Full Graphics Capability - 64 graphics blocks and on MX80 FT/2 high resolution graphics.
- *Fast through-put - 80 characters per second, bi-directional, quasi start line logic seeking.
- *Full Control - with a variety of print densities to 132 columns and top of form, horizontal and vertical tab controls.
- *Reliability - Precision engineered quiet operation. Full twelve months warranty.

THE EPSON DISTRIBUTOR

Micro Peripherals

61 New Market Square,
Basingstoke, Hampshire RG21 1HW
Tel: 0256 56468 (4 lines) Tlx: 858575

Ring lan for up to the minute prices and technical information on a whole range of Japanese Micro Products

To: Micro Peripherals, 61 New Market Square, Basingstoke, Hants.
Please send me full details of the EPSON range including printout.
Name..... Position:.....
Company:.....
Address:.....
..... PC5/81
(BLOCK CAPITALS PLEASE)

• Circle No. 141

RAM

THE LOW COST
WAY TO EXPAND
YOUR MEMORY

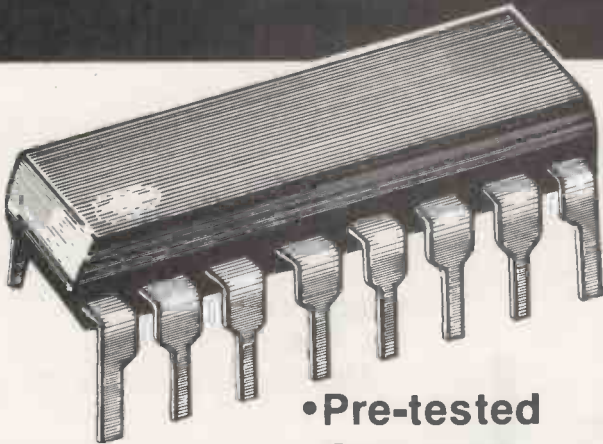

- Pre-tested
- One year warranty
- Available now

Apple is a trademark
of Apple Computer Inc.

16K RAM-£35.00
32K RAM-£65.00

Inclusive of VAT and carriage

Please write for order form now

MICROTECH

Box 76, World Trade Centre,
Europe House, London E1 9AA

• Circle No. 142

Trouble with computer
supplies?

Poor quality!

Delivery delays!

Suppliers lack
product knowledge!

Try us

A. W. Hawkins & Co. Ltd.

We can supply a wide range of:

- Ribbons
- Listing Paper
- Daisywheels
- Floppy Disks

From stock at
competitive prices.

A. W. Hawkins & Co. Ltd.

1-5 Clerkenwell Road
London EC1

Tel: 01-253 0768



• Circle No. 143

THE WEST LONDON microcentre

6 Pavilion Parade, Wood Lane, London W12 0HQ Tel: 01-743 9000

'Apple means business'

If you think a microcomputer might help in
your business — perhaps you should be
talking to us.

We take care of our customers.

We are geared to provide a complete range of
microcomputer services. If you wish, we can:

- tailor the hardware to suit your exact needs
- find you the right programs
- provide all consumables
- train your operators
- maintain your hardware

And we stay in touch to answer
your questions and sort out any
problems.

All this at prices you can afford.
Even the most expensive
system is unlikely to cost
more than £5000.

Leasing terms are available.

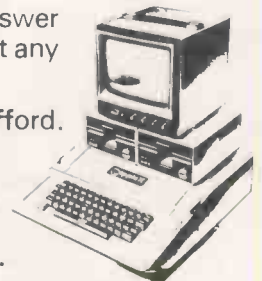

01-743 9000

apple II

• Circle No. 144

Is it time you had an Electronic Assistant in the office?

The micro chip has brought affordable computing to the small business and professional practice, as well as to individuals and departments in large organisations. Desktop computing is now a practical reality for a host of tasks that were too expensive or impractical on big computers. The microcomputer has become an Electronic Assistant in the office.

Number Cruncher

An Electronic Assistant can help collect, store, calculate and analyse numerical data. Microcomputers are aiding accountants, actuaries, administrators, analysts and architects. Budgeting, pricing, costing and estimating are just a few practical applications.

Word Processor

Change the disc and your Electronic Assistant becomes a word processor. It will help with proposals, contracts, reports, documents, price-lists, mailing and all those other wordy office tasks.

Information Retriever

Your Electronic Assistant will keep a file of personnel, pupils, properties, patients. Find what you want, when you want it. Match people to jobs, children to schools, buyers to houses, patients to treatments. Retrieve files and print information at the touch of a button.

Business Minder

And of course your Electronic Assistant will help mind your business. Send bills, keep

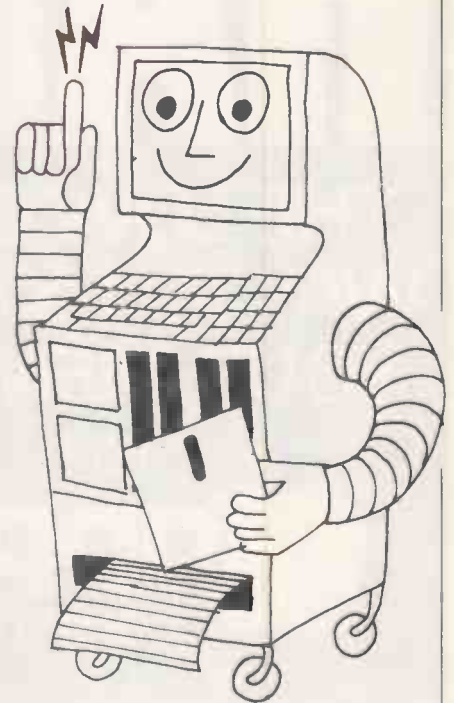

accounts, process orders, take stock. Give you time to look at the business information you've never had time to analyse properly.

Micros Can Grow on You

Microcomputers are cheap enough to add a second machine as jobs grow. Replicate them to perform similar tasks in different locations. Link them together in a local network. Program them to talk to big computers.

Ask Digitus to advise you and supply an Electronic Assistant to suit your present and future needs.

Call: 01-405 6761 or write for information to: Digitus Limited, 9 Macklin Street, Covent Garden, London WC2.

DIGITUS - ELECTRONIC ASSISTANTS IN THE OFFICE

Digitus

Digitus specialises in microcomputing, communications and the electronic office. The Company provides complete systems for the small business, professional practice and large organisation. Costs vary between £3,000 and £30,000 per system depending on facilities. We acquire software packages and equipment from all over the world to satisfy requirements and have the capability to put machines and software together, adding the special features you need.

Financing the future

THERE ARE TWO sides to the micro business: the fun and thrills of making machines do things no-one in their right minds would even consider and there is the small matter of staying alive while you do it. It is accepted on all hands that Britain's salvation is to be found through microelectronics, and that it is the prime duty of government and industry to foster this delicate plant.

There is an impressive list of organisations willing — nay, anxious — to fund the micro entrepreneur. There is the National Research and Development Corporation, NRDC, the National Enterprise Board, NEB, the Industrial Commercial Finance Corporation, ICFC, Department of Industry's software support scheme, and the Department of Industry itself. The clearing banks have "start-up" schemes for small businesses. Elaborate and expensive committees look into the situation and regularly report that there is no shortage of money for investment — rather, there is a shortage of projects.

The micro business is very like the Wild West, and, as in any frontier town, the sheriff — your genial editor — is apt also to be the local seed merchant. Thus it is with us. As well as running this delightful magazine, I have a software publishing business. What concerns us here is the light my experience sheds on the way the micro industry is actually funded.

We start at Christmas 1979 with a list of projects and a way of doing business. We go to NRDC who say yes; the whole project looks interesting, the products seem sound, both technically and from the marketing point of view. They want to become involved in the micro business and they will think about it — urgently. We are still waiting for an answer to the letter asking for support, dated November 1979.

ICFC: they think it's a topping idea — well, kind words cost nothing — but they are not really interested in research and development. Perhaps a little later on? A little down the road? Yes, fine, fine. Nice to see you. Do come back — when you do not need us.

NEB: prostrate from the INMOS deal, there seemed little point bothering them with a request for a few piffling thousands. Your friendly local bank is advertising easy finance for small businesses; bank manager says he does not know much about software, but will think about it. Thinks and advances nothing but the neat idea that if we put up £15,000 cash, the bank will match it with a two-year loan at 21 percent — repayments to start immediately.

At last, a gleam of light in the gloom. At the Department of Industry — whose Information Technology Division contains some patient people who clearly want to be helpful — mention is made of the Software Products Scheme, SPS, which is managed for them by the National Computing Centre. Haven't you heard of it? It's just what you need. The SPS gives approved products marketed by approved companies a choice of support: you can have 25 percent of your projected costs as a gift, or 50 percent as a loan, repayable as a percentage of gross income. Better still, the SPS is intended to help with marketing as well as development.

It sounded too good to be true. I spend a great deal of time thinking how much it might take to sell the two products we have finished, and then to finish and sell two more products which were in embryo. It is rather like guessing the length of four expensive pieces of string. Finally, the proposal is sent to Manchester. After the usual silence, back comes the answer, no.

Why not? Long telephone conversation with a frank and helpful man. Firstly, SPS is designed to help small software houses.

PL: You can't get smaller than us. We haven't even got a dog.

SPS: Ah, you misunderstand me. When I say small, I mean turning over, say, £60,000 or less. With accounts for only five years.

PL: But the whole micro industry is less than three years old.

SPS: Ah, well, there you are. There is another difficulty. Two of your products are finished, you say?

PL: Yes, you can see them running.

SPS: Well, the SPS is not really designed to support marketing alone.

PL: But surely it's better to put public money into something which works rather than something which might work? Less, how shall we say, risky?

SPS: That may well be so, but it's not how the Treasury sees it.

PL: So, if we had been going five years and hadn't done any work, you might help?

SPS: Not so fast. How many full-time employees have you?

PL: Thank God, none. Everyone works on a royalty. Like a book author.

SPS: Well, that puts the lid on it. You must have three full-time technical employees.

PL: That's £40,000 a year.

SPS: And anyway, I don't see in your accounts that you have the money to match what you're asking us to give you.

PL: Of course we haven't. If we had any money we wouldn't be going through these loops.

SPS: You have to convince us that you can put up your 75 percent or 50 percent of the money your firm needs.

PL: We can't, but what about this? You agree in principle that certain expenses qualify for support under the SPS. When we've paid a bill in one of those areas, we'll send it to you and you give us 50 percent. In that way, it doesn't matter that we don't have the money now. We must have found it because the bill will be paid before you see it.

SPS: That would be retroactive financing. The Treasury would never hear of it.

PL: Thank you so much for your time.

Some of the wisest words ever printed in this magazine were these: "When we first started, we believed that if we had substantial backing, we could have made a fortune very quickly. In retrospect, we simply would have lost all the money. We might still have come in the right direction but our mistakes would have cost money rather than just time. I don't think that in the long term, if you are determined to make a business work, backing on a large scale is worth it, especially if you do not have a good deal of business experience". Mike Fischer on the start of Research Machines, *Practical Computing* April 1980 page 84.

True enough for the individual small company. Yet notice the trade-off between time and money. Time is what Britain does not have very much of. Our rivals are putting a great deal of money into the microelectronics industry. They are forging ahead, in their fields, at an impressive rate.

It happens that our microsoftware industry is — potentially, at least — spread among many people who work in back rooms. What we need is some way of giving them small amounts of money while accepting the risk that only one in 10 will pay off. What is £5,000 or £10,000 put into 100 small firms compared to the umpteen billion hurled daily and irretrievably into heavy industry?

If microelectronics is going to produce a new cottage industry, we have to be willing to support people in cottages with talent but no capital — not in the crumbling palaces of dying industries. If this frightens the Treasury, we will be able to congratulate ourselves on having expired in complete financial rectitude.

Had we but world enough and time.

This coyness, Minister, were no crime.

Our Feedback columns offer readers the opportunity of bringing their computing experience and problems to the attention of others, as well as to seek our advice or to make suggestions, which we are always happy to receive. Make sure you use Feedback—it is your chance to keep in touch.

Friend or foe?

WITH Boris Allan as a friend, who needs enemies? Though I tend to agree with his argument, I found his article confusing — December 1980 issue. For a more direct example, this program contains both a recursive, FNF, and iterative, FNG, method of determining the factorial of a given number. As can be seen, they give identical results on the HP-3000.

```

FACT
10 LONG A
20 INPUT "FACTORIAL ",A
30 PRINT FNF(A)
40 PRINT FNG(A)
50 GOTO 20
60 DEF LONG FNF(LONG N)
70 IF N=0 THEN RETURN 1
80 ELSE DO
90 IF N<0 THEN RETURN 0
100 ELSE RETURN N*FNF(N-1)
110 DOEND
120 FNEND
130 DEF LONG FNG(LONG N)
140 LONG R
150 R=1
160 IF N=0 THEN RETURN 1
170 ELSE DO
180 IF N<0 THEN RETURN 0
190 ELSE DO
200 FOR I=1 TO N
210 R=I*R
220 NEXT I
230 RETURN R
240 DOEND
250 DOEND
260 FNEND
>RUN
FACT
FACTORIAL 3
6.000000000000000L+00
6.000000000000000L+00
FACTORIAL 30
2.652528598121911L+32
2.652528598121911L+32
FACTORIAL 50
3.041409320171338L+64
3.041409320171338L+64
FACTORIAL
*CONTROL-Y BREAK IN LINE 20 IN FACT
>

```

Now, I doubt that anyone could suggest that either solution is the better one, in terms of aesthetic appearance. Both are simple, and both reflect the algorithm adopted. However, FNF uses a method which is a step removed from the normally-used definition of a factorial — as used in FNG — and it is this extra step which makes the program more difficult to follow.

Personally, if I had to use the factorial in a program — and, in 17 years of computer work, I have used recursion no more than three or four times, and the factorial never — I would use the recursive method because of its conciseness. However, it is extremely wasteful with stack space, and on smaller machines, I might be forced to use the iterative approach.

Paul Farrell's letter, Feedback, February 1981, on the other hand, gives a perfect

example of recursion being used in its proper place. Unfortunately, the outside world of commercial computing is not so well-defined, and I fear that most computer people's experience is similar to mine — recursion is one of the hundreds of techniques we have in our armoury but which is rarely used.

Doug Scott,
Maidstone,
Kent.

Liverpool MuPet

IN CASE Pet users are rushing out to buy the MuPet multi-user system, following your highly favourable review, February 1981, may I add two points of caution.

First, our MuPet has the most disconcerting habit of hanging-up in operation. The cause is unknown but the effect is disaster, for the whole system, including the Pets, is frozen and the only remedy is to power-down and start again. If two or three users are in the middle of program development work, the result is anger and chaos. As an add-on re-set switch is available for the MuPet in the U.S., it suggests that this particular problem is not uncommon.

Second, and of great importance to systems set up solely for package job running, is our MuPet's total inability to do batch printing. Thus, if two or more Pets are running print-output jobs, the printing is inter-leaved. This is inevitable, as the Print statement in Pet Basic closes-down the printer channel after execution and leaves it available for further calls. If the next call is from another Pet — perhaps while the original Pet is doing some processing — interleaving of print runs is the result.

Despite the claims that no program changes are necessary to run on the MuPet, the only way to overcome the problem is a complete re-write of all our programs to ensure that all print statements are placed together thus forcing domination of the channel.

GSP Thomas,
University of Liverpool.

Sorcerers' coven

WHEN THE Sorcerer was first introduced in early 1979, two separate user groups were started. One, based in Woking, Surrey, never got off the ground. The other group, started in June 1979, has been in continuous production ever since.

This second group was started at a time when there was a great shortage of software for the Sorcerer and so one of its main aims in those early days was to spread programs within the group. For

this reason, the group name Sorcerer Program Exchange Club, SPEC, was chosen.

It soon became apparent that there were problems involved in distributing cassette tapes. These problems were technical, logistic and not least legal. Therefore, it was decided to play down the program exchange part of the group and to concentrate on the newsletter side.

In view of the misleading nature of the title SPEC, it was decided late last year to change it to something more suitable. The group's membership is very widespread with members in Australia, New Zealand, Hong Kong, U.S.A., Canada and every country in Europe with a particular concentration in the Netherlands.

Because of this mainly European rather than British membership, we decided to rename the group the European Sorcerer Club — or ESCape as it has become known within the group. Incidentally, the reason for the predominance of Dutch members is due to the Dutch TV service running a computer course which used the Sorcerer as the preferred machine. They beat the BBC by about 18 months.

For further details write to me, Colin Morle, 32 Watchyard Lane, Formby, Near Liverpool L37 3JU. Telephone 070-48-72137. Subscription costs £5 per annum if you live in the British Isles and £7 for elsewhere in Europe; outside Europe, the cost is £12.

Colin Morle,
Formby,
Merseyside.

Teaching quality

THE ARTICLE by M P Thorne in *Practical Computing*, January 1981, on poor-quality mathematics software evokes a great deal of sympathy. It was satisfactory to note that the programs which were praised were from good educational backgrounds.

When other aids to learning, such as books, are produced, authors' names are given. Teachers rightly view with suspicion any materials for which no educational sources are given; this certainly applies to computer programs. I suggest that the following points be looked for when buying educational software:

- The material should have sound educational origins based on teaching experience and on sound educational theory and practice. Full explanations should be given in teachers' notes and student leaflets.
- The computer program and documentation should be written by someone with experience in writing educational software — or under such a person's guidance.

(continued on page 44)



The Professional PSU

Based on the "TOROIDAL TRANSFORMER"
Six new computer power supplies at a
SPECIAL INTRODUCTORY PRICE
TO END OF APRIL ONLY

Don't delay — post today — limited stock

Type A. 8V @ 8A, +15V @ 1 Amp, -8V @ 1A, Unregulated	£29.00
Type B. +16V @ 3 Amp, -16V @ 3 Amp, Unregulated	£26.95
Type C. +8V @ 10 Amp, Unregulated	£27.25
Type A/R. as Type A, but Regulated to +5V, +12V, -5V	£39.90
Type B/R. as Type B, but regulated to +12V and -12V	£38.50
Type C/R. as Type C, but regulated to 5V @ 10 Amp	£34.23

Add 15% VAT and £1.50 Post and Packing
Allow 21 days for delivery Parcel Post

All regulated supplies have current limiting and over volts protection.
Professionally made by established company.
Other types available — send sae with enquiries for quote.

TO: — IMAC LTD., Unit 1 Dodnor Industrial Estate,
Newport, I.O.W.
Please send me PSU, Type I enclose my
cheque/P.O. for £ which includes £1.50 post and
packing and 15% VAT.
Please debit my Access/Barclaycard No.

ACCESS																			
BARCLAYCARD																			

• Circle No. 146

Mailing Floppy Disks?

Use Swan Disk Mailers — and get
Safety in the Mail

Now used by over 1,000 computer companies,
Swan Disk Mailers provide outstanding postal
security at economical prices.

Combining great strength with simplicity of use,
Swan Disk Mailers are manufactured from rigid white
corrugated, holding up to four disks.

There are two sizes available: 8-75" X 8-75" & 6" X 6"



ring
01 609 1746
for Free samples
and prices

• Circle No. 148

OHIO SCIENTIFIC COMPUTERS

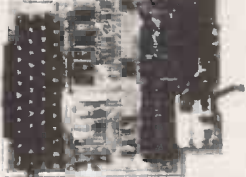

CHEAPO EXPANSION OFFER

Buy a 610 expansion board with 8K ram
on board and space for another 16K for
£159 and get a free 5V 4A power kit
and any extra ram you want for £3/K.
Buy a minifloppy + case + power supply
+ 2 copies of DOS for £275 and we will
do the extra ram for £2/K (Max 16K). We
can also supply a version to suit UK101.

SUPERBOARD 3 SPECIAL OFFER OF THE CENTURY.

Only Swanley could do it!
For just £159 we will supply Superboard
3 with a free power supply and modulator
kit and our free guard band kit (A
brilliant break through in itself for this kit
extends the display to 32 x 32, allows
1200 as well as 300 Baud tape speeds,
increases the computing speed by 50%
and converts the display to 50Hz for
flicker free viewing).

SUPERBOARD ACCESSORIES

4K extra ram £16.95. Case £27. Cassette
recorder £18. Cegmon improved monitor
rom £29.50. Wemon improved monitor
£19.95. Assembler/Editor tape £25. Word
processor £19. Extended monitor tape £20.
Display expansion kit 30 lines x 54
characters for Superboard 2 (not 3) £20.

SERIES 2 CHALLENGER

Microcase versions 4K £202. 8K £219.

PRINTERS



Buy any of the below and get a free
interface kit and word processor program
for UK101 or Superboard: —
OKI Microline 80 (Illustrated) £329.
Epson MX80 tractor £359. Epson MX80
tractor + friction £399. Epson MX70 £279.
Epson TX80 £295. Base 2 800 MST £299.
Seikosha GP80 £225.

5V POWER KITS

Fully stabilized 5V computer and TTL
power kits. Automatic current limiting
and short circuit protection. Crowbar over-
voltage protection. 1 1/2 A £7.83, 3A £12.17.
6A £17.39.

MEMORY CHIPS

2114 450ns £2.15. 4116 200ns £2.83.
4027 £1.30. All low current.

ZX80 Secondhand poa.

SWANLEY ELECTRONICS

Dept. PC, 32 Goldsel Rd., Swanley, Kent BR8 8EZ.

Postage £3.50 on computers, £4.50 on printers and 45p on other orders.
Lists 27p post free. Please add VAT to all prices.

Office credit orders welcom. ZX80 part exchange possible.

• Circle No. 147

Computers for All

2 KING EDWARD ROAD, ROMFORD, ESSEX
TEL (70) 26220 (24 hrs)

ACORN ATOM

FROM **£120** +VAT

Send now for further details.

FREE! with each Atom.

1 cassette containing
THREE superb games for
the Atom. Normally retails
for £11.50.

ATARI VIDEO

COMPUTER SYSTEM™

Best selling TV computer
games console can now be
yours for only **£89.95**

incl. VAT. Delivery extra.
A wide selection of Games
Program™ cartridges in
stock From **£14.95** incl. VAT

SPACE INVADERS

Only **£24.95** incl. VAT + P&P

Sharp PC1211

Only **£79.95** +VAT

Sharp Cassette Interface CE121

£10.95 +VAT

Sharp MZ80K

From **£440** +VAT

Apple/ITT 2020

From **£625** +VAT

plus a selection of accessories

Odds n'Ends

RAM chips for Apple/
ITT 2020 8 chips per set
£30.00 +VAT.

Blank Floppy Diskettes
(Box of 10 in plastic case)
£22.00 +VAT

Blank C12 cassettes **37p**
each. Hand made, high
quality, 5 screw casing.

TRADE ENQUIRIES WELCOME

Add £1.50 P&P per order

• Circle No. 149

(continued from page 42)

- Both teacher originators and programmers should have the backing of some group or organisation for discussion in the early stages.
- The whole unit should be edited, preferably by someone — or some persons — with considerable experience of teaching the subject matter and of computer education.
- The unit should have been on school trials and revised in the light of comments received.
- The names of the teacher originator(s), programmer(s), editor(s) and of the group organising discussion trials and production should be given.

Programs from the Schools Council project, Computers in the Curriculum, director R Lewis, the leading producer of educational software for secondary schools in this country, and from other projects such as ITMA will be found to satisfy these criteria.

It is not meant, in any way, to discourage teachers and their computing friends from producing their own programs to meet specific needs, nor from exchanging such programs with their friends. Such authors would do well to note some of the snags which Thorne mentions, and also to consult the project papers produced by the Computers in the Curriculum project. Especially relevant are paper 17 on guidelines for authors and paper 14 on the project's aims and methods in producing materials in mathematics.

**Donovan Tagg,
Lancaster.**

Statistical errors

THE PROGRAM described in the article, Statistics on a micro, *Practical Computing* February 1981, is very interesting and ingenious but unfortunately contains a number of errors. To save anyone who wishes to run the program the trouble of debugging it, here are the errors which I have found.

Lines 15, 35 and 915 can be deleted as they only duplicate other lines. Lines 640 and 660 appear to have some characters missing. These lines should read:

```
640 IF NA = 0 THEN Z = 1 : GOTO 740
660 IFTA > TB THEN U = UA : M = NA :
GOTO 680
```

In line 550 the subscript for SB should be NB and not MB as shown. Perhaps the worst error occurs in line 2000. Not only is the program incorrect but the error has been repeated in the text describing it. The maximum value of the last element in Q should be N - 1 and not M - 1 as stated.

For those whose Basic does not have the If Then Else form of decision statement, I would suggest that subroutine 2000 be rewritten as follows:

```
2000 IF Q(M-1) = N-1 THEN RETURN
2010 Q(M-1) = Q(M-1) + 1
2020 GOSUB 4000
2030 GOTO 2000
```

With these corrections, I have run the program successfully on a Pet. The only

further changes required were the deletion of line 10 and references to the strings A and B made in the conventional form of A\$ and B\$.

**J Halliday,
Port Talbot,
West Glamorgan.**

Solid advice

I HAVE been repairing radar and electronic instrumentation for some 20 years now, so am reasonably sure of my soldering. I bought myself a computer kit, regularly advertised in your pages.

Had I had problems with bad joints or duff components there would have been no problem. However, the plated through holes in the board were intermittent. All components in the kit were guaranteed, of course, but in the case of the board, once my iron had made the first joint the supplier could and would say that I had damaged it.

A repair service was offered, but having spent the best part of a month's wages, another £25 was throwing good money after bad — especially as the nature of the trouble was such that I could see the computer commuting between Derby and London for months on end.

So, my recommendation to anyone buying a kit, is this: pay the extra for a ready-built machine, preferably from a supplier who has enough confidence in his product to give a year's guarantee. Make sure you have some protection.

I would go further and say: treat it as roughly as possible, short of visible damage, to try and show up any incipient open circuits.

**J Bland,
Derby.**

Old-ROM update

IN FEEDBACK, February 1981, I wrote about the updating of old-ROM Pets to the newer Basic 2 versions. Since my letter was published I have had a letter from the sales manager of Commodore U.K. which says that I have my facts wrong. I had obtained my facts from Commodore U.K. at Euston Road, London.

The facts given in the letter from the Commodore U.K. sales manager are as follows:

- Machines with 901447 series ROM chips require a set of four ROMs to update, these are and always have been £38 the set.

- Machines using 6540 ROM sets require seven chips to update. They are £104 the set.

- However, as a gesture to good customer relations, Commodore is now making these ROM sets available for £38 — all prices exclusive of VAT. Official Commodore User Club members can obtain these ROM sets free if they buy a disc drive.

It would seem sensible for anyone contemplating updating an early 8K machine to purchase ROM sets now — the current prices may not last for ever and at £38,

they are being sold at below cost price.

**J A Banks,
Loughton,
Essex**

Micro leasing

IN THE March issue of *Practical Computing*, in your article, Is it worth leasing a Micro?, you quoted my company's bureau charges as £100 establishment fee, with weekly charges of £110. I must point out that this figure would reflect the average monthly cost to maintain a sales ledger of roughly 100 accounts.

Our weekly charges are based on a run charge and then prorata, based on input and output volumes. When one considers that the fees also embrace on-the-job training for our users, our charges become the most cost-effective way of implementing a computer system.

**Malcolm Harvey,
West One Computer Services
London W1.**

- In case it was not clear from the March 1981 article on leasing micros, Malcolm Harvey and Roger Martin both worked for CSC when they were in Nigeria.

Electronic accounting

I WAS interested to read the comments of G D Herbage of Gnomist International Ltd, March 1981 Feedback, on the need for a business accounting packaged based on the well-known Kalamazoo system.

In collaboration with B & D Steels Ltd, Altrincham, Cheshire, we have developed just such a system, based on the TRS-80 with 48K of RAM and four mini-floppies. It has now been in operation for more than a year. The system was run in parallel with the Kalamazoo cards for one month only — the changeover was so smooth that it was felt that the cards could be safely dispensed with after that time.

According to Robin Lucas, chief accountant of B & D, the ease of the transition was largely due to the fact that the entry procedures closely followed those of the Kalamazoo system, with which they were already familiar.

**George Sassoon,
JZK Electronics,
Warminster,
Wiltshire.**

Kalamazoo's answer

IN MARCH 1981 Feedback, G D Herbage referred to the need for a ready-to-go microcomputer package capable of replacing the Kalamazoo or similar accounting method and costing less than £5,000.

Readers with similar interests to those expressed by Herbage may like to know that Kalamazoo will shortly be launching just such a package for use with a new range of microcomputers.

**P J Rex,
Kalamazoo Ltd,
Birmingham.**



**dy
san** *Dysan Diskettes*
FROM STOCK

30,000 Diskettes is our stock level !
FOR IMMEDIATE DELIVERY

Call Ann Perkins or Dan Taylor
on **Dysan Hotline: Weybridge (0932) 48346/7**

HAL COMPUTERS LIMITED
57 Woodham Lane, New Haw, Weybridge, Surrey KT15 3ND.

TWO SUPPLIES HOTLINES !

Continuous PRINTED

WORD PROCESSOR LETTERHEADS

from 1000 on 70 or 85 gsm Paper
plus Daisy Wheels & Ribbons

Continuous SELF ADHESIVE LABELS

- | | |
|--|---|
| * Single and Multi-Part Forms
from our standard sizes to suit
your systems. From 1000. | * Full Artwork Service. |
| * Self Design Layout Sheets. | * Listing & Word Processor Papers. |
| | * Diskette & Microfiche
Storage Systems. |
-

Call Bob Humphrys or Richard Wells
on **Forms Hotline: Weybridge (0932) 48218**

PRINTOUT BUSINESS FORMS

57 Woodham Lane, New Haw, Weybridge, Surrey KT15 3ND.

Printout Business Forms



ZX-81 — lower price for higher performance

A PERSONAL computer from Sinclair Research launched to replace the popular ZX-80 is priced at only £69.95 and is now in production at the Timex factory in Dundee. Based on an innovatory four-chip design, the Sinclair ZX-81 also sells in kit form at £49.95 — the mains adaptor is an extra £8.95.

At the launch of the new computer, its designer, Clive Sinclair, claimed that in the U.K., his ZX-80 is now outselling all other personal computers put together and he confidently predicted that by

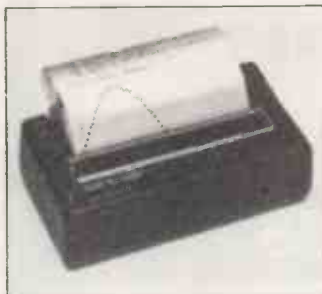

The ZX printer.

the end of 1981, Sinclair Research will exceed the production volume of any other personal computer manufacturer in the world.

The key design achievement in the ZX-81, which is constructed in thick black plastic, is a new master-chip custom-built in the U.K. by Ferranti. It replaces 18 chips in the ZX-80 and adds some new features. The ZX-81 has a Z-80A micro-processor and an 8K Basic ROM which allows floating-point arithmetic and gives full scientific functions.

The new computer embodies all the main features of its predecessor including single-stroke key word-entry, automatic checking of every statement line and a display of 24 lines by 32 characters.

New features, in addition to a print-drive facility, include the ability to operate in two software-selectable modes, fast and normal — fast is four times the speed of normal. In normal mode the Sinclair ZX-81 will compute and display simultaneously and allows

continuous moving, flicker-free graphics.

A 40-key, touch-sensitive membrane keyboard gives the equivalent of 81 keys using function mode and single-press key-word systems. The graphics mode enables an additional 20 graphical and 54 inverse video characters to be entered directly from the keyboard.

Programs can be loaded and saved on a conventional home cassette player and re-selected from the computer keyboard. The cassette-interface facility has been improved to overcome some of the ZX-80's loading problems and programs are given names so the ZX-81 can search through a tape for the required program. There is also a new 200-page instruction manual.

The new 8K Basic ROM used in the ZX-81 will shortly be available to ZX-80 owners as a drop-in replacement chip, supplied with new keyboard templates and operating manual. It will enable the ZX-80 to offer all ZX-81 features except flicker-free graphics.

Sinclair has also announced that a printer for the ZX-80/81



Sinclair's ZX-81.

computers will be available in June for around £50. It will offer full alpha- numerics across 32 columns and includes a command, COPY, which prints out exactly what is on the TV screen.

In the first nine months since the ZX-80 was launched in February 1980, 50,000 of the computers were sold — about half of them in the U.K. Since then, the units have been sold at the rate of about 10,000 per month with 30 percent going into the U.K. market. Production of the ZX-81 began in March at the rate of 10,000 per month.

Pet displays its multi-lingual prowess with Cytek device

CYTEK (U.K.) Ltd of Manchester has launched a device which enables the Pet to display multi-lingual text on its screen. The device, Multifont, works in conjunction with the Wordcraft word-processing system. There are five main versions of Multifont; scientific, legal, commercial, European multi-lingual, non-European multi-lingual. Each version can format the special characters relevant to its application.

Multifont is used in conjunction with any 32K Pet, and any version of the Wordcraft program and the Qume Sprint 5 series of daisywheel printers. The operator can see the effect of using different print-wheels without printing anything.



This is achieved by matching the characters within the computer to those on a specified print-wheel.

Up to four separate fonts can be stored in the computer at any one time — the first is the standard Commodore business set. Multifont does not occupy any of the Pet memory, so the operation of the computer is not affected.

A total of 73 fonts are

Health hazard of VDUs

IN RESPONSE to a call from a conference on the health and other hazards associated with the use of VDUs, a research project has been initiated by the Institute for Consumer Ergonomics.

The conference was entitled Health hazards of VDUs, and was held by the Husat Research Group, of Loughborough, Leicestershire. It was the widespread concern voiced by delegates at the conference which prompted the research.

The project is to be funded by the EEC coal and steel community, and will be carried out in those industries. Certain others will participate by contributing financially or by allowing access to sites.

It is intended to research into the incidence and severity of the various types of discomfort and fatigue caused by these units, and in certain cases, to specify the ergonomic requirements necessary for the optimisation of VDU use with regard to the existing constraints.

The Institute for Consumer Ergonomics would be pleased to hear from companies thinking about VDUs and their use, and anyone else involved in similar research.

available for the Qume printer and 29 keyboard sequences. The Multifont fonts correspond to these sequences, and since one sequence may be used by several different type-faces, the four available fonts could cover many print-wheels. Keyboard overlays are available to enable the operator to identify quickly and easily all the characters in the sequence and locate the appropriate keys.

Cytek can create Multifont sets to user's own specifications if required and groupings other than the main five can be provided. Multifont is available as an add-on to Wordcraft at £172 + VAT and a complete system is £4,200. For information telephone Cytek on 061-872 4682.

Educational grant

A GRANT of £60,000 has been made by the Council for Educational Technology as part of a micro electronics education programme. Initially, the project will take the form of a course to be run at and by the Thames Polytechnic for teachers in such subjects as biology, geography and economics.

The course lasts 10 weeks, is attended by teachers on secondment from local authorities and it is specifically aimed at those teaching in secondary schools. □

Acorn picked to make new machine for BBC series

ACORN COMPUTERS has landed the job of building the new BBC microcomputer — and the projected BBC-TV series *First Byte* will use an extended form of Atom Basic in its instructional material.

Acorn describes the new machine, which will retail for less than £200 and should be ready by the end of 1981, as “a condensed version of the forthcoming Proton”. Its specification was devised by a BBC team which included

Charles Sandbank, head of BBC Research, Richard Russell of BBC Designs, who styled the exterior and John Coll, president of MUSE. Other consultants included Ray Kernow, John Sweeton and Peter de Bono.

The specification of the new micro is for 16K of RAM as standard, with the potential for expansion to 96K; add-on teletext receiver at a cost of around £100; add-on Prestel interface; high-quality moving keyboard “with a positive action like a top-class electric typewriter”; ultra high-resolution graphics in black and white — 640 horizontal points — a feature which it is claimed can be found only on micros costing more than £1,000; colour graphics at a lower level of resolution; and potential for networking with other computers or peripherals.

Initially, the requirement was for a Z-80 processor, teletext capability and CP/M support, but intensive discussions throughout the industry showed that it was not possible to have a machine built in Britain within the time limit. The Z-80 requirement was scrapped but Acorn has been able to meet the others within the time limit. A new BBC Basic to be called ABC was to have been developed but this too was dropped for lack of time.

Not all within the industry are, however, agreed that the

BBC tried hard enough for what it wanted. Clive Sinclair, at the launch of the ZX-81, indicated that he could have built such a machine for a price of £110 at the point of sale — sales will be by the manufacturer under licence to the BBC and marketed on behalf of the BBC by mail order from a box number.

Sinclair tells *Practical Computing*: “We did quote for it. We had a specification from the BBC but it wasn't very full and there were some ambiguities in it. We said we could build it for £110 but it was clear our bid wouldn't come to anything. We had to put in a bid to protect ourselves.

“We feel that the BBC should have talked more to the industry and made the specification better known. We think it's crazy. Here we are trying to compete with the world's industry and our own national broadcasting system is operating against us”.

Charles Sandbank of BBC Research disagrees: “The BBC has taken advice from a great many people with experience of the micro industry”, he says. “As an employer of engineers, I think it's a worthwhile machine but it's a very difficult decision. The BBC has gone into it very carefully and has done all the right things and has gone for the solution which seems to have the highest probability of doing what it wanted”.

Acorn Computers will also supply some of the software, which will be written in Atom Basic, adapted for compatibility with Microsoft Basic. Proposed programs include how to plan your electricity use more economically, work out your tax liability, learn maths, spelling or typing, manage business accounts or run an office. There will be hobby programs to interest the amateur astronomer, musician or photographer.

A 30-hour course will be run by the National Extension College at Cambridge to tie in with the TV series, and several course books are planned. □

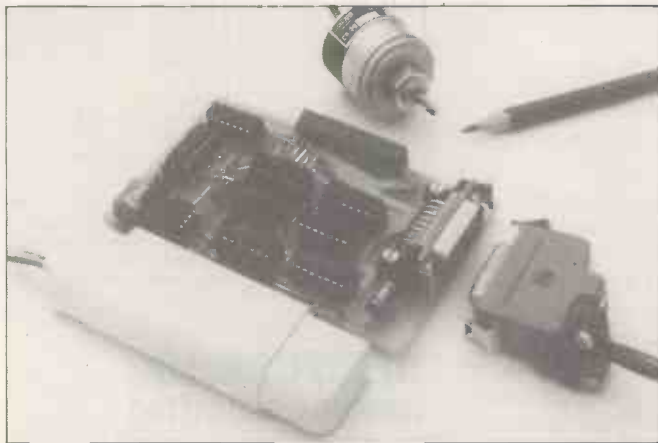

Pet users involved in mechanical data logging and position control may find this shaft position encoder from Cetronic Ltd of use. Recently added to the Commodore-approved product list, the C030C absolute optical shaft encoder will enable a Pet computer to communicate with mechanical systems in the real world using a specially designed interface. The encoder will be capable of resolving mechanical rotation into 256 eight-bit words, utilising grey code to increase the reliability of the readings. An interface/decoder board is supplied to convert the grey code to binary and feed it to the Pet via the input port. Cetronic may be contacted at Hoddesdon Road, Stanstead Abbots, Ware, Hertfordshire SG12 8EJ, telephone 0920 871077. □

Texas 16-bit TMS-9995 wins added operation speed

TEXAS Instruments has developed a 16-bit micro-computer in a 40-pin package which includes the 6MHz clock generation, 256 bytes of fast RAM, an interval timer and the necessary circuitry for handling prioritised interrupts.

The device, called the TMS-9995 to indicate its generic link with the 9900 family, was designed and developed by Texas Instruments at its Bedford location. The generic link with the TMS-9900, TMS-

9980, and SBP-9900 family of processors gives it complete software compatibility, so that a range of component software is already available.

However, the TMS-9995 has a significantly superior performance. The instruction set is that of the TMS-9900 with the addition of four new commands which enhance its ability to perform numerical tasks. There are also two new system interrupts, one of which, the arithmetic overflow, helps

speed maths operations by handling overflow conditions without resorting to extra software.

An evaluation board will soon be available for the TMS-9995 which contains a monitor for program assembly, editing and execution. The hardware contains two data links.

The TMS-9995 is fabricated using NMOS and operates from a single +5 volt supply and will cost £23 for quantities of 100 plus. □

Three good reasons why professionals pick Apples

1. In research

Apple desk top computer systems help you collect, store and analyse data as fast as you can load and execute a program. There are many software programs for Apple which enable you to manipulate your data in the computing world. If you need special programs you can now use any of Apple's development languages – Basic, Fortran, Pascal, Cobol and Pilot.

2. In engineering

Apple desk top computer systems let you define models and refine prototypes. Do you want to study cause and effect of several variables? Apple can compute new results instantly and display them in colourful, easy-to-read graphs, charts or plots on a video monitor.

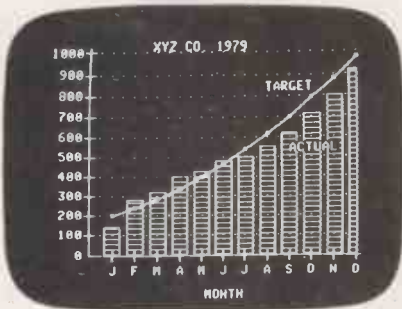

3. In production management

Apple desk top computer systems make it simple to gather data, analyse productivity, measure yields and facilitate all phases of production control. Do you want to speed up repetitive tasks? You can rely on Apple's word processing capabilities to write, edit and print your reports and data.

Apples grow with you

Whichever system you choose, Apple never locks you into a single configuration. You can use up to eight I/O accessory expansion slots to add an IEEE bus, Apple's Silentype™ printer, a modem or a Graphics Tablet. You can add up to 64K bytes and 5¼in. disc drives without adding any overhead. For support, service and the best extended warranty in the industry – Apple is the answer. If you have any other questions about why Apple is chosen by professionals in engineering and science, see your nearest Apple Computer Dealer.

Apple II	
Maximum Memory Size	64K bytes
Screen Display	40 column (80 column with peripheral card) 24 Lines
Screen Resolution (B & W)	Upper Case 280 × 192
Screen Resolution (Colour)	140 × 192 (6 colours)
Keyboard	Fixed
Numeric Key Pad	Accessory
Input/Output	8 expansion slots
Disc Drives	Add-on one to six drives
Languages	BASIC Fortran 77 Pascal Assembly Pilot Cobol
Typical Configuration	48K RAM Apple with BASIC, single disc drive, B & W Monitor (9" I. Silentype™ printer.
Suggested retail price	£1,666.00*

For details of the numerous programs available for Apple and the name and address of your nearest Apple Computer Dealer, please complete the coupon below and return it to Microsense Computers Limited, Finway Road, Hemel Hempstead, Herts HP2 7PS. FREEPOST.

SOLE UK DISTRIBUTOR

**microsense
computers limited**

Finway Road, Hemel Hempstead, Herts HP2 7PS
Hemel Hempstead (0442) 41191 and 48151
24 hour answering service, Telex: 825554 DATEFF G

* Price exclusive of VAT and correct at time of going to press.

* Apple is a trademark of Apple Computer Inc, Cupertino, California, USA.



Please send me full information on the Apple computer, the Apple software booklet and my nearest Dealer. I am interested in how Apple can help me in:

- Science Research Engineering
 Production Management Business

Name: _____

Position: _____

Company: _____

Address: _____

Post Code: _____

Telephone Number: _____

Profession: _____

PC5

• Circle No. 151

How you and your machine can make beautiful music

THE LATEST product range from Alf Ltd will turn an ordinary Apple II computer into a sophisticated musical instrument. Two music boards which plug into the Apple expansion socket, and some associated software including an ear-training package and a collection of Albums are available on cassette or disc.

The MC-1 music card has nine independent channels or voices. Each voice is monophonic — it can play like a one-fingered keyboard player. The use of more voices means that chords can be formed or the computer could use a voice to provide its own accompaniment.

Three voices provide the left stereo output, three the right and the remaining three play

through both speakers to provide the middle. The voices have individual control over pitch, envelope, and volume and one voice from each of the three stereo positions can be used to create white noise effects. This would be of great use to users synthesising percussive effects such as cymbals, etc.

The MC-16 music board is similar but provides only three voices on one output channel. This reduction in voices is compensated for by the inclusion of some extra features; a range

of 63 half-tones as opposed to MC-15, more volume control levels and an ability to have two channels with variable pulse-width mode; the frequency is controlled by the third channel.

The software provided with the boards is comprehensive, will provide the user with a colour graphic display of the music being played. Songs can easily be entered from sheet music and the display shows the music on the screen.

When you enter music, a menu of available notes is

displayed and an arrow indicating the selected note is manoeuvred by the paddle. The other paddle is used to position the note on the staff which is also displayed on the screen. A subroutine facility enables the user to call-up passages which need to be repeated and there is also an editing facility. The MC-1 card costs £91 and the MC-16 £114 and both are available from Apple dealers. □

Apple sees to the lighting

AN AUDIO-visual system which uses an Apple II computer as its base is now being introduced to the U.K. The Superstar multivision computer system can be used to program the batteries of slide projectors and ancillary equipment used for multi-projector slide presentations.

The "professional" multivision production market has so far been dominated by



The system in action.

dedicated microprocessor systems. The Apple-controlled system could also be used to run standard Apple software.

The Superstar system consists of an Apple computer, twin disc drives, a 9in. VDU and a Universal Interface which allows dissolve units, slide projectors and auxiliaries such as lights, motorised curtains and film projectors to be driven from the computer.

The system was developed by Clear Light in Florida and uses its own high-level language for programming the light sequences. Details in the U.K. from Myriad, 01-240 1941. □

Keeping school-leavers in the pink and micro firms in the black

ON THE one hand, we have the typical micro firm and on the other, an impending tide of school-leavers who have all played with computers and look forward to exciting jobs in the microrevolution.

The problem — to bring the two together without breaking the banks of one or the hearts of the other. One solution might be the Youth Opportunities Scheme, YOP. The central idea of YOP is to introduce out-of-work school-leavers, 16-18, to the world of work. The Government's part is to pay them a tax-free allowance of £23.50 a week for six months — the sponsor's part is to have them around the place and show them, in a reasonably humane and constructive way, how the real world earns its bread — and perhaps butter. One hopes that by the end of the six months, or sooner, they will be so useful they are offered a full-time job.

It seems possible that there might be places in micro businesses for such young people, especially if they already have some idea of programming.

To get this scheme off the ground, the Manpower Services Commission has to be presented with a draft scheme of activities which will be approved centrally and then

passed to local Job Centres for action. Our suggestion for such a program might be:

- Introduction to company and what it does.
- Basic office procedures: keeping records, filing correspondence, liaising with customers/clients.
- Computing: keeping records, making back-ups of programs and data, simple applications programming.

The scheme's main stipulations are:

- The company must have three full-time employees

but it may employ more.

- The young people on the scheme must not replace any full-time employees.
- Their work must conform to health and safety regulations.
- They must not work nights or Sundays.

Anyone interested should write to us with suggestions. Literature about YOP is available from Miss J Trenor, Manpower Services Commission, Selkirk House, 166 High Holborn, London WC1V 6PF. □

Software is neither cheap nor indestructible. Discs left lying about in offices seem to attract tea and other spills or are knocked to the floor — before you know when you are, next week's payroll data is corrupted. The new data storage aid from Rexel has been designed to make the storage and retrieval of floppy discs a simple matter. The storage aids are in the form of binders, with pockets made of tough Nyrex material to hold the discs. The system will also consist of labels to help identification. Further details from 0296-81421. □

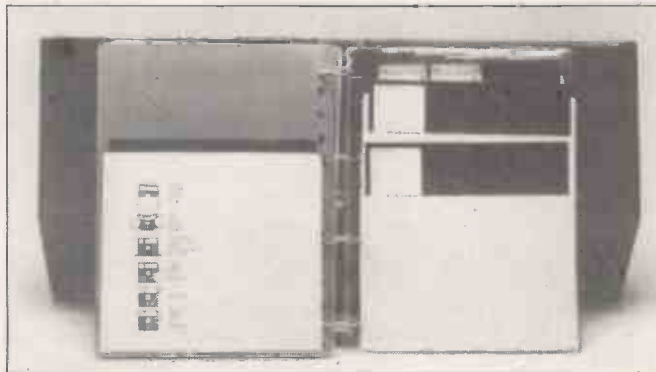

Gateway is Prestel's route into new teletext territory

PRESTEL is to offer a new service later this year. Mysteriously known as Gateway, it will permit Prestel users to access third-party databases. Based on a system already operating in West Germany, with software developed by Systems Designers under contract to Aregon International, Gateway is expected to enlarge greatly the scope of Prestel when it is fully implemented in 1982.

Key to the system is the so-called Gateway frame which leads the user from the Prestel network into a privately-owned computer, all of whose facilities may then be enjoyed by the user, assuming, of course, that he is in possession of the relevant password.

A demonstration at the London Prestel headquarters hosted by Prestel boss Richard Hooper, showed Gateway in

action live from West Germany, whose *Bildschirmtext* is closely modelled on Prestel although there are as yet only two computers.

There were two short demonstrations, one of a customer-account enquiry and one of a conversion from sterling into U.S. dollars. This kind of networked information retrieval and processing is nothing new, of course; but it will be the first time this type of access has been feasible through Prestel.

Gateway's advantages, according to Iain Chisholm, who is in charge of marketing, are fourfold:

- It puts far greater processing power in the hands of a user who already has access to Prestel.
- There is great flexibility in security arrangements for different categories of information — even a single page can have its own security password.
- It makes keyword searches available.
- Interactive transactions via Prestel are now a possibility. At present you may send a message via Prestel but there is no acknowledgment that the message has been received and acted on.

Paper Tiger trio

THERE ARE three new Tiger printers on the market, replacing the old Tiger 440. They are distributed through Microsense and the nationwide network of more than 400 Apple dealers. At the bottom of the range is the Tiger 445, an impact printer with a full 96-character upper- and lower-case set, a choice of eight user-selectable character sizes, graphics option, tractor-feed and multiple-copy capability. The 440 can print at speeds of up to 95 characters per second.

Next in the range is the 460 which because of an unusual

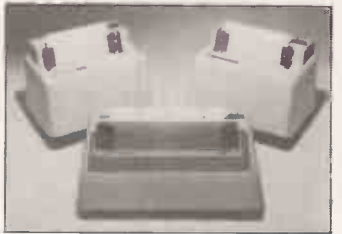

The Paper Tiger family.

matrix head will print denser, higher-quality characters. It is bi-directional and can print at speeds in excess of 150 cps. At the top of the range is the Tiger 560, a 132-column matrix printer with graphics and an expanded buffer. It is intended for data- and text-processing.

The prices for the range are; 445, £545, 460; £795, and 560; £995.

Triumph-Adler micros enter the field

THE Triumph-Adler group, owned by the West German industrial giant Volkswagen, has finally made its move into the small-business microcomputer market with the launch of its Alphantronic range of systems.

The Alphantronic is based on the 8085A microprocessor chip running at 3MHz. There are two basic configurations of the system: the standard P1 at £1,550 which includes the processor, VDU, an integral double-density floppy disc unit and full documentation written in clear English; the P2 has a further floppy disc drive and a dot-matrix printer and costs £2,345.

The outstanding feature of the Alphantronic is the large amount of applications software already available for the system, including programs written by larger software houses. Among the software is a payroll program called Flexipay, written by Compuserve. There is also a business software package which consists of several modules; payroll, sales,

Microsense is bought

MICROSENSE Computers of Hemel Hempstead, Hertfordshire, the sole distributor of Apple Computers in the U.K. has been purchased by Apple for an undisclosed sum. The transition is expected to be completed by the autumn.

Microsense will become a subsidiary of Apple.

purchase ledger, nominal ledger, and stock control with a sales invoicing option. The program is written by Tridata of Birmingham.

Microtrend has produced a complete range of software for the system, including a word-processing system, a data-management package which apparently has helped to sell many Alphantronics already, two user-friendly commercial accounting packages and Basic teach-in, a computer-aided learning program designed to teach beginners Microsoft Basic. Adler Business Systems Ltd, 27 Goswell Road, London EC1M 7AJ. Telephone 01-250 1717.

Sophisticated Micromodeller to be distributed by ACT

ACT Microsoft — one of two British computer companies quoted on the Stock Exchange — has become the sole U.K. distributor of an important new software package designed to run on micros.

The product is called Micromodeller and is a low-cost financial-modelling package for the Apple II, developed in Britain and U.S. by Intelligence (U.K.) Ltd. David Low, managing director of ACT comments: "Each year, two or three software packages of real significance emerge — Micromodeller is one of these".

ACT is already the sole distributor of VisiCalc, the best-

selling program in the world last year, and envisages Micromodeller emulating its success. Its main appeal will be to the small-to-medium-sized businesses and the middle layer of management in larger concerns.

Micromodeller represents a fraction of the yearly bureaux fees a comparable facility would cost, plus it has the added advantage of being a personal system — at less than £4,000 a system, everyone in a company needing the facility could have a personal system.

Like VisiCalc, the program is user-friendly — the commands are in plain English. It has a menu and is supported

locally by the dealer and nationally by a hotline. Financial functions are built-in, and reports are generated automatically to the user's own specifications. Summary reports can be displayed on the screen before any printing is performed.

An attractive feature of Micromodeller is the slideshow presentation, which uses colour graphics to present information in a graphical form.

This useful facility will, no doubt, help to sell the package to those people whose job entails disseminating financial information.

BLACK BOX III MICROCOMPUTER SOLUTIONS

Conventional microcomputers can have problems – too little memory, not enough storage, poor communications, no expandability. RAIR's Black Box III range provides all the solutions. With up to 512K bytes of memory, 200M bytes of

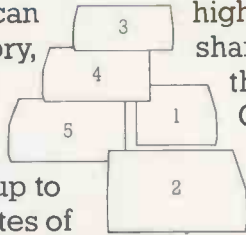

high-speed hard disk, 16 simultaneous users, and shared-resource multi-computer networking, the only thing micro about the Black Box III is the price. Call your nearest Dealer for details.

- 1 Single mini-disk system
- 2 Dual mini-disk system
- 3 Single mini-disk plus 5" hard-disk system
- 4 Single 8" hard-disk system
- 5 Add-on 8" hard-disk



RAIR

Healey Office Equipment Unit 7, Westfield Industrial Estate, Portsmouth Road, Horndean, Hants Tel: 0705 597555
 Digitus Ltd 9 Macklin Street, Covent Garden, London WC2 Tel: 01-405 6761 Hallam Computer Systems Ltd 1 Berkeley Precinct,
 Eccleshall Road, Sheffield S11 8PN Tel: 0742 663125 Holdene Ltd Manchester Unity House, 11-12 Rampart Road, Leeds Tel: 0632 459459
 Lion Micro Computers Ltd 227 Tottenham Court Road, London W1 Tel: 01-636 9613 and 21 Bond St Brighton Tel: 0273 601838
 Micromedia Systems, Seymour House, 14-16 Chepstow Road, Newport, Gwent Tel: 0633 59276 NSC Computer Shops 29 Hanging Ditch,
 Manchester Tel: 061-832 2269 T & V Johnson (Microcomputers) Johnson House, 75-79 Park St Camberley Tel: 0276 20446 also
 148 Cowley Road, Oxford Tel: 0865 721461 and 48 Gloucester Road, Bristol BS7 8BH Tel: 0272 422061

Rair Limited, 30-32 Neal Street, London WC2H 9PS Tel: 01-836 4663

• Circle No. 152

51

WOULDN'T YOU LIKE AN OSCAR FOR A SUPERB PERFORMANCE



To a casual glance, we must admit that there are several other computers which superficially resemble OSCAR. However, if you peek under the stylish structural foam housing, with its separate keyboard for better ergonomics, you'll notice the differences.

S100 SYSTEM

OSCAR has a 6-slot motherboard, housed inside the VDU housing, with proven IDS S100 cards to international standards for a flexible, easily maintained, system.

4MHz Z80A PROCESSOR CHIP

Possibly the most powerful m.p.u. chip in its class, running at full speed, makes OSCAR more powerful than many mini-computers.

64K DYNAMIC MEMORY

A full sized system for your full sized applications.

DISKETTE OR HARD DISK

The options are yours, starting with twin floppies at 400KBytes per drive or an 11MBytes Winchester located inside the VDU housing.

Maximum size? We're not saying, as we keep on increasing it, but it's unlikely to be too small.

CP/M™ OPERATING SYSTEM

Use of the industry standard CP/M™ Operating System means that a wealth of applications software will run on your OSCAR.

VISUAL DISPLAY UNIT

With the green phosphor recommended by opticians for low eyestrain, the VDU also has a bonded face-plate for extra safety. There is a full character set with real descenders on the lower-case letters. There are 24 lines each of 80 characters.

KEYBOARD

Separate keyboard with full QWERTY and numeric pad for fast entry.

PRINTER OPTIONS

A range of printers is available. Your dealer can help you select the appropriate one for your requirements.

APPLICATION PROGRAMS FREE

Sales, Purchase and Nominal Ledgers plus Stock Control and Payroll are available from your dealer and to avoid the problems of pirating, all you have to pay for are the manuals and the media. If these packages do not suit, your dealer will be able to offer alternatives, although, these are unlikely to be free!

NATIONAL SERVICE NETWORK

It's no good owning the best system if you can't get it mended, so IDS have arranged for a National Service Network to offer maintenance contracts on your OSCAR.

PRICE

An OSCAR with twin floppies costs from £2,495.00 (excluding VAT and printer)

NOW

Cut along this line, complete and post for further details.

Designed and manufactured in the United Kingdom by:-

INTERACTIVE DATA SYSTEMS LTD.

14 Heathfield, Stacey Bushes, Milton Keynes MK12 6HP

Buckinghamshire, England

Telephone (0908) 313997

Please send details of OSCAR and your other S100 products to:

Name _____

Position _____

Address _____

Company _____

PCS/BI

• Circle No. 153

• Circle No. 154

CENTRONICS 730

SPECIAL PRINTER OFFER £375 VAT EXCL

STANDARD FEATURES

10 CPI

- 100 characters/second
- 80 characters/line

16.5 CPI

- 165 characters/second
- 132 characters/line

- 10 CPI or 16.5 CPI selectable by software command.
Expanded character selection for both 10 and 16.5 CPI.
- 3-way paper handling: A4 cut sheet, paper roll and fanfold.
 - 7 x 7 dot matrix
 - 96 character ASCII plus five selectable European character sets
 - Microprocessor electronics
 - Unidirectional print at 10 IPS
 - 6 LPI vertical
 - Centronics colours and logo

INTERFACES

- Centronics Parallel (Standard)
- RS 232/V24 Serial (Option)

RIBBON SYSTEM

Continuous ribbon 9/16" (14mm) wide, 20 yards (18.3 meters) long
Mobius loop allows printing on upper and lower portion on alternate passes.

OPERATOR CONTROLS

- Power on/of
- Reset switch — allows disabling of printer without dropping AC

DATA INPUT

7 or 8 bit ASCII parallel, TTL levels with strobe
Acknowledge pulse indicates that data was received.

ELECTRICAL REQUIREMENTS

60 Hz; 115VAC, +10%/—10% of Nominal
50 Hz; 230VAC, +10%/—10% of Nominal

PHYSICAL DIMENSIONS

Weight: less than 10 lbs./5 kg
Width: 14.5 inches/37cm
Depth: 11.0 inches/28cm
Height: 4.89 inches/13cm

Dimensions exclusive of roll paper holder.

TEMPERATURE

Operating: 40° to 100°F (4.4° to 37.7°C)
Storage: —35° to 140°F (—37.2° to 60°C)



HUMIDITY

Operating: 20% to 90% (No Condensation)
Storage: 5% to 95% (No Condensation)

FORMS HANDLING

Roll Paper: 8.5 in. x 5.0 dia. with 1 in. core maximum dimension.
3.5 in. wide with .38 in. core minimum dimension

Fan Fold: 9.0 in./22.9cm wide pin to pin
9.5 in./24.1cm wide overall

Up to 3 ply paper with 2 carbons (total thickness not to exceed .012 inches)

Cut Sheet: Maximum width 8.5 inches

FREE! Personal Computers 132 column software option.

Personal Computers Limited

194-200 Bishopsgate | London EC2M 4NR

Telephone: 01-626 8121

TABS

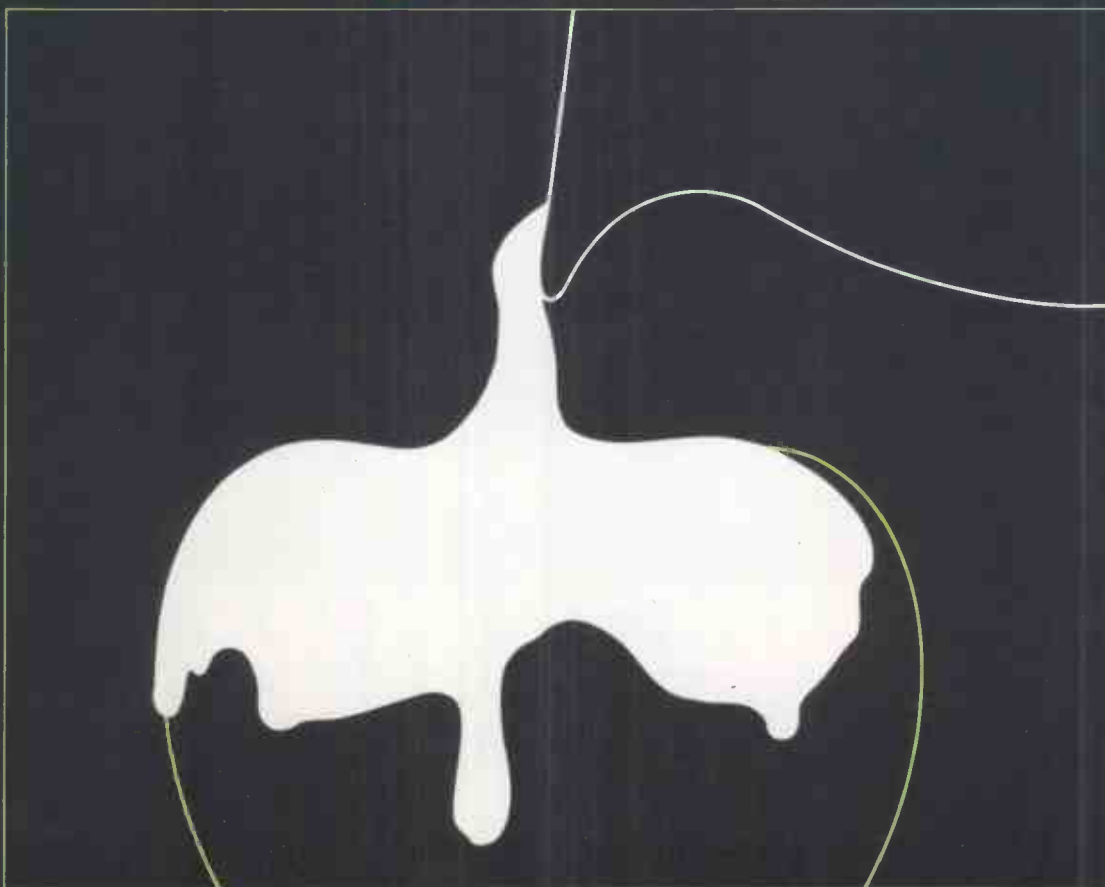

The cream for your apple.

Within the space of a few short months, TABS has rapidly become established as the best accounting software on the market for APPLE II.

Our unique modular accounting system, developed for the APPLE II microcomputer, has been designed specifically to meet an increasing demand from the small business.

The fully integrated system enables modules to be used independently or together so that as business expands so does the system simply by adding a new module.

To ensure that our low cost accounting system* is fully understood, TABS offer a full support service, through our national dealer network, that includes training courses, consultancy and free seminars.

Modules include: Purchase Ledger, Sales Ledger, Nominal Ledger, Payroll, Stock Control, Job Costing, Word Processing, Training, Support, Management Accounts, Invoice Compiler, Fast Data Entry, Sales Order Processing, Mail List.

£99

Each module costs an astonishingly low

*The minimum system required to run the TABS modules is:

Apple 48K, Disk with controller. Disk without controller, Silentyper printer, TABS Firmware card, total cost £2056

54

Expanding Dealer Network

LONDON Eurocalc Ltd 01-405 3223, Lion Computers 01-636 9613, Marchessa Ltd 01-726 4809, Micro Control Ltd 01-402 8842, Time & People Ltd 01-242 4706, **AVON** C & G Computer Group Ltd 0934 417724, Datalink Micro-Computer Systems Ltd 0272 213427, **BERKS**, Hexagon Services 0753 21998, **BUCKS**, Chiltern Computers 0296 32642, Chiltern Office Efficiency Ltd 02405 72777, **CAMBS**, Top Mark Computers 0480 212563, **CHESHIRE** Systems Integration 061-928 5784, **CORNWALL** Diskwise Ltd 057-93 3780, **ESSEX** Compuskill 0708 751906, Meclec 03708 5047, **GLOS**, Casa Management Consultants Ltd 045383 4551, William John & Co 04536 70109, **HANTS**, Access Control Systems Ltd 0730 5274, Grist Business Services 0703 39061, Logan Electronics Ltd 0425 619761, **HERTS**, H G Services 0727 30129, Lux Computer Services 0923 29513, **HUMBERSIDE** Computer Facilities Ltd 0724 63137, **KENT** Microlen Computers Ltd 0732 845412, Microspot 0622 858753, **LANCS**, K C Business Systems 0254 676077, Lancaster Computer Services Ltd 0772 31030, **LINCOLNSHIRE** Estate Computer Systems 0529 305637, **MANCHESTER** Shannons Radio Ltd 061-748 2339, **MERSEYSIDE** Micro Digital Ltd 051-227 2535, Rockcliffe Micro Computer Division 051-521 5830, **MIDDLESEX** Microsolve Computer Services Ltd 01-951 0218/9/0, **W. MIDLANDS** Micro Business Centre Ltd 0902 725687, Westwood Computers Ltd 021-632 5824, **NORFOLK** Anglia Computer Centre 0603 29652, Carlton Computers Ltd 0493 58897, **NORTHANTS** Co-Compute Ltd 0604 33767, **OXFORDSHIRE** Courtland Electrical 0865 779282, **SALOP**, Cressage Computer Services 0743 69009, **STAFFS**, Abel Computer Systems Ltd 0827 50804, **SUFFOLK** Blyth Computers Ltd 050-270 371, **SURREY** Ramm Computer Services 0284 64045, Aero-Gemsoft Ltd 04862 22881, Ferguson Computer Services 09323 45330, **SUSSEX** Ilexford Ltd 0273 23020, Datex Micro 0903 39290, **I.D.T.** Computers 044-483 370, Oval Computer Systems 0903 501355, Supabeam Computer Services 0403 61647, **STAFFS**, Britannia Computers Ltd 0384 233433, **WORCS**, Capricorn Computer Systems Ltd 0905 21541, Mike Dennis Associates Computer Systems 0386 48240, **S. YORKS**, Hallam Computers 0742 663125, **EIRE** Teletone Ltd Dublin 715954, **N. IRELAND** Medical & Scientific Computer Services Ltd 08462 77533, **SCOTLAND** Scotbyte Computers Ltd 031-343 1005, Gate Microsystems Ltd 0382 28194.

If you are interested in TABS low cost Accounting Business Systems, please tick box(es) and return this coupon to us.

User enquiry

- Please send me an invitation to a free seminar.
 Please send me the TABS User Manual
 I enclose £5 (postage and packing included)

Dealer enquiry

- Please send me details of your Dealer Plan

NAME _____

ADDRESS _____

Tel. No. _____

PC5/81

TABS Ltd, The Old Rectory, Blackford, Wincanton, Somerset.
 Telephone: North Cadbury (0963) 40164

Accounting
Business Systems
TABS

Low-cost Wordease fits the bill for office applications

THE GREATEST weakness of Wordease lies in its documentation. Written with the computer buff in mind, the documentation for this otherwise extremely useful program is guaranteed to frighten away anyone unfamiliar with computer terminology. It is written using a wealth of technical jargon, it does not contain worked examples which might at least have made Wordease a little easier to use and it contains a few minor inaccuracies.

I do not consider myself a computer whizz-kid, but at the same time, I think I know enough about the subject to be able to have a commercial program up and running as quickly as the next person. Yet by the time I had unraveled the vectoring to my existing print routines and had persuaded the program to read my standard keyboard, it had taken me four hours to load and run Wordease.

Another four hours passed before I was able to use it to any real purpose after which I was on the learning curve which should have been reached after a single reading — or, at most, two readings — of the manual. The typical user of the program, say, typist or secretary with no special computer knowledge, might abandon the program because the initial learning hump is just too steep. That would be a shame because when used at its best, Wordease is a print formatter *par excellence*, comparing well to many modern typesetting machines.

So what is Wordease? It is described as a text editor and text processor and its use is clearly divided into these two separate functions. As a text editor I found it inferior to Naspen — the only Nascom-based competitor in the same price and size range, reviewed September 1980 — but that as a pre-print processor, it is extremely versatile and capable of producing complex multi-page documents easily and to a very high standard.

Available controls

Assuming a memory already full of text, the more obvious controls are easily available. Scrolling-up and down through the buffer, inserting and deleting, finding and replacing pre-defined strings — all with full on-screen cursor mobility — is straightforward and a bytes-remaining display is available although it is updated only occasionally when text is processed but not during normal entry.

The speed, incidentally, of such actions as insertion or replacement is particularly impressive and is achieved through the use of a "playground" area — an interesting and useful way to increase text processing

Nick Laurie analyses the strengths and weaknesses of Wordease, the word-processing package for Nascom.

speed. For further details read Wilkes: *Scroll editing*, IEEE transactions on computers volume 19, number 11, November 1970.

The find command is also capable of handling wild characters embedded as asterisks in the find string. There is, however, a serious disadvantage — it is a line-based editor with all the action except entry taking place on a single edit line — line 8 on the screen — and the text is reflected on to the screen exactly as it appears in the buffer.

Blank lines

There is no tidy-up routine so that words wrap around from one line to the next. It is essential, therefore, to hit newline at the end of each screen line for tidiness — fine for touch typists but hell for two-finger Peek and Poke types. Insertions and deletions have an unnerving habit of leaving blank lines and odd word-breaks permanently inserted into the text.

The general untidiness is cleared-up in the processed output but not in the buffer and it makes editing of text on the screen into a very disjointed affair and really prevents Wordease from being used extensively for original writing. On the other hand, when large blocks of the text are standard as is often the case in business letter writing, the program really saves time.

By using the so-called macro commands, it is possible to store up to 10 text sections which can be called up by referring to them by number in the body of the text. They will be inserted and formatted automatically leaving, for example, only the names and addresses of a standard letter to be defined by the operator.

Two such macros are dedicated to providing the page headings and footings and can include automatic page numbering as well. Very useful when a multi-page report is being prepared. A macro can contain an embedded instruction to call up another macro — and so on to the full depth of 10 — so allowing considerable versatility.

As well as these normal editing features, there are a number of commands available for use in a direct mode. 'U' and 'D' followed by a number will cause the screen display to scroll-up or down by as many lines as required while 'T' and 'B' put the top or bottom lines respectively on

to the edit line. A software shift lock is available.

Text on the edit line can be marked and new markers — maximum of two, to define a single block of text — adjust themselves automatically to point towards each other so that, as new markers are added, the nearest old one is deleted and the new one points towards the remaining one. Marked areas can then be copied to any required line or killed.

Again, the fact that the editor is line-orientated may mean that some fine shuffling is needed to place text at exactly the right spot. A save command feeds the marked area direct to cassette or disc in some systems and the saved text can be replayed direct to the edit line as though it were from a keyboard. Misread characters are displayed as '?' to allow easy recognition. The KILL command is the only command that has to be spelt in full — just as well since it is not possible to recover killed text. 'Q' or quit returns control to the system monitor.

The final command as far as the editor is concerned is 'P' for process and it leads us to the second and, to my mind, far more impressive face of Wordease.

Format and output

The purpose of the processor is to format and output the contents of the text buffer to one or more of the three ports. Each of the ports is a vector to a user-defined — and user-supplied — output routine. Typically, port 1 would be sent to the screen to provide a view of the general appearance of the formatted text while the second might be directed to a printer operating routine with the third going to a tape or disc system. All three ports have to be vectored by the user so that any output routine can be used.

Unfortunately, the manual again assumes that the user is used to fiddling about in individual memory locations in machine code and keeps explanations of procedure to a minimum while the occasional inaccuracy in the memory map provided does little to help find the proper location. Each vector is followed by a control word which can be set to any of the following options:

1. Character delay feature on or off
2. Use Nascom I carriage return code
3. Inhibit line feeds
4. Force upper-case — capitals

(continued on next page)

(continued from previous page)

The control word, inserted by the user in Hex, can be the sum of any of these options to give different controls on different ports. The required port or combination of ports is selected by entering the command 'Pn' where 'n' is the port number followed, if required, by a 'Dn' command which sets the pre-coded port delay factor to control the character output speed while 'Pn' defines the page number of the first page output in multi-page documents.

Text is processed from the buffer as a single continuous string and is justified automatically whether you want it so or not. I consider this to be a fault since, if a line is to be printed unjustified, it is necessary to insert a specific command into the text each time this format is required.

With the current ubiquity of word processors, there is a tendency for everyone to produce tidy, justified output on any three-by-two dot-matrix printer and this tends to give an appearance on a par with the resprayed banger or the gilded stinging nettle.

On poorer-quality word processors, the justification routines can lead to a gappy appearance and the overall result is that the style of computer-generated word output is becoming very recognisable — and not for its better qualities either. There are times when one would like to pretend that a letter has been hand-typed and at such times, the forced justification is a positive disadvantage.

Error message

During the processing it is possible, or even probable, that errors caused by the use of inappropriate or conflicting commands will occur. An error message is displayed and a jump made to a vector defining your machine's "bell" routine — very useful if you want to leave your machine during processing. If no bell is available, the Hex command C9 is inserted in the bell vector and the error message is displayed silently.

While most of the error messages are self-explanatory, the fact that they are not explained in the manual is a fault which does nothing to help the slope of the learning curve. Processing is halted when an error occurs and the offending line of buffer is placed on the edit line.

Unfortunately, the precise spot at which the error was found is not marked and, bearing in mind that there may be 12 or more commands embedded in a line of text, it can call for a good deal of studying to find the mistake. That again is not a fault exclusive to the system but one which I have encountered on other machines costing upwards of £15,000.

The formatting commands consist of 14 very comprehensive codes which can be inserted into the body of the text to tell the printer exactly what to do when they are encountered. Imagine you have written and edited your text, you have pre-defined

a number of macros for your standard paragraphs and it is now time to think about printing.

Going through the text line by line, you insert commands into the text at each point where the printer has to do something other than print justified words — it can do that with no commands beyond a defined line length. Insertion of control 'C' — an up-arrow, 5E Hex — indicates to the processor that the following character is a command — which will not, of course, be printed — at which point the processor interprets the next character and controls the printer accordingly.

These characters are 'Ln' which is used to set the line length. Here and in all commands using a numeric suffix, 'n' is a decimal number which defaults to 1 and is to the command character. Beware, though, of numbers which are part of the text to be printed; if they follow a command, a separating space must be used to avoid confusing the system.

'D' and 'S' set the line spacing to single- or double-spaced, 'I' sets an indent causing printing to start at column n on all lines until the command is cancelled using IO, while 'T' for tab causes a once-only tabulator to column 'n'. 'N' prints a new line while 'E' for eject prints new lines until the end of the page, whose length is initially defined using 'Pn', is reached.

A very clever conditional eject 'Cn', operates the multiple line feed only if there are fewer than 'n' lines left on the current page and would, for example, be used before a chapter heading to avoid printing it at the foot of the page.

The last few commands complete the system: 'F' for finish which outputs new lines to the end of the page and then halts the printer; an 'H' simply halts the printer until any key is pressed allowing the user to change the sheets in a sheet-fed printer and it would normally be included in the foot-of-page macro which is referenced whenever a page has been completed.

This same macro would usually contain the 'X' instruction to print the current page number — three digits, leading zero suppression. 'Un' is a user command allowing decimal 'n' to be output to the printer for special-purpose control codes such as a printer on/off switch. One handy feature of the commands is that they can be entered in upper- or lower-case which helps to avoid errors.

In spite of the apparent complexity of reading the text buffer once it has been padded out with commands, one can grow used to it very quickly with regular use. With practice, it is possible to read a piece of text, visualise the finished appearance required and then insert the control codes to produce it. Many a sub-editor would be able to master the machine — given a decent manual — in minutes.

A trial run formatting to the screen is essential to check that everything you wanted happened and it is a shame that this output is, in effect, lost once it has scrolled off the screen. Ideally, it should

replace the existing buffer string with the processed string to allow further editing to take place.

Once satisfied with the format the print process command is given and manuals, books, circular letters can be churned out *ad nauseam*. The *Wordease* manual is produced on *Wordease* and is a model of tidiness — visually, if not in terms of content.

In large volumes, it is still far less expensive to typeset and print using slightly less modern techniques than to use impact printers and photocopying. That is because the area of paper required for typeset material is far less than it is for type-written material and on a 30- or 40-page manual, the reproduction costs of a mass of paper far outweigh the savings made by avoiding professional typesetting.

I have used *Wordease* to format and print a number of experimental pieces and found that with practice — and, preferably, some familiarity with modern photosetting techniques — it is invaluable in the preparation of complex reports and standard letters although practically hopeless for original or creative writing.

The ideal user for *Wordease* would be the small business involved in the continuous generation of similar but non-identical material such as an estate agent or mail-order company. Such a firm might well consider dedicating a Nascom and printer solely to this purpose at a very low cost indeed. A copywriter or an author not requiring the powerful processing on offer but needing detailed and tidy editing facilities would go out of his creative mind in a very short time.

The fact that this editor seems to be geared for report writing and standard letter writing rather than to creation of original material gives *Wordease* the appearance of either having been built specifically for a particular job and then marketed as an afterthought or of simply being another half-completed program rushed on to the market ahead of time.

Wondering which answer was correct I had a word with Program Power who distribute it and I was put in touch with the author, TR Harris of Vader Systems in Portsmouth who confirmed that he wrote it with a view to satisfying his own needs — mostly for standard letters — and that the marketing followed when various people expressed interest. Hence the documentation and low cost — £25.

Conclusions

- *Wordease* is very much a purpose-designed program and while it may be unsuitable for many people, those whose interests lie in the production of standard letters, complex multi-page documents and short runs of things like instruction manuals will find it superb.
- It is at its worst for creative writing.
- It does everything it is supposed to do and does them well, but it may not do everything you would like it to do. □

A Word Processor, Report Writer, Mailing System, Data Base Manager, and a Computer all for £1995*



Yes, we are offering all this with our SERIES 5000 5" floppy-disc system for the incredibly low price of £1995.*

Not only do you get a powerful Z-80A system on the S-100 bus built to high quality standards by Industrial Microsystems, one of the longest and best-established companies in the microcomputer industry, and supported by Equinox, specialists in microcomputers and multi-user systems.

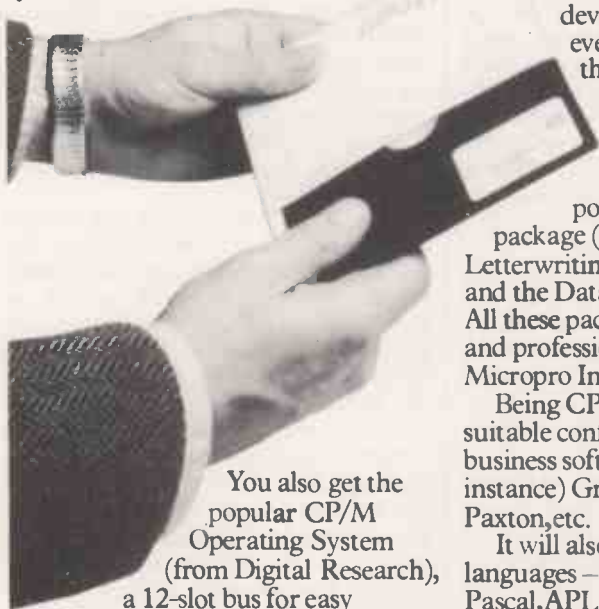

You also get the popular CP/M Operating System (from Digital Research), a 12-slot bus for easy expansion, a Z-80A CPU for powerful performance, 2 serial and one parallel interfaces, 64KB of dynamic RAM with in-built error detection capability,

and dual 5" double-density drives with the option of a third drive (or quad capacity drives in place of double-density) in the same cabinet. Additionally, there is the Turbocharger option providing both enhanced disc capacity, disc performance and diagnostics. And if even greater storage is required we can supply 8" floppy drives and cartridge disc drives.

A powerful system for the computer-user and system developer – and one with eventual access to OS/2000, the Industrial Microsystems networking system.

And for the office or business user we are including as standard a powerful Word-Processing package (Wordstar), a Mailing and Letterwriting package (Mail-Merge) and the Datastar Data Base Manager. All these packages are widely accepted and professionally written by Micropro International.

Being CP/M based, the system with suitable configuration will also run the business software developed by (for instance) Graffcom, Peachtree, Paxton, etc.

It will also run a wide range of languages – Basic, Cobol, Fortran, Pascal, APL, Algol, C.Lisp, and Forth and will support a wide range of add-on S-100 devices, such as floating point processors, Prestel interfaces, speech synthesisers, digitisers and plotters, etc.

And just to make certain that you get full use out of your system, nationwide field service support is available at a modest extra cost.

* add VAT and the terminal and printer of your choice at the costs shown.

Series 5000 with 64KB Dynamic RAM, dual 5" double density drives, CP/M Operating System, Wordstar, Mail-Merge and Datastar £1995

The same system with quad drives in place of the double density drives £2230

Add-on double density drive £290

Add-on quad drive £405

Peripherals:
Televideo 912C VDU £595

Elbit 1920X VDU with Wordstar keyboard £895

OKI Microline 80 printer £595

Texas 810 150cps printer £1450

NEC Spinwriter RO Word processing printer £1850

All prices exclude VAT, carriage, training and installation and are subject to our standard terms and conditions.

OEM dealer and educational enquiries welcome.

EQUINOX

COMPUTER SYSTEMS LIMITED

Kleeman House, 16 Anning Street,
New Inn Yard, London EC2A 3HB
Tel: 01-739 2387/9 & 01-729 4460

• Circle No. 156

Business computing combination of Equinox and MVT-Famos



EQUINOX Computer Systems Ltd is a British company based in London and was established three years ago, in July 1978. That was at the height of the initial wave of enthusiasm about microcomputers. At that time, most suppliers were selling computers for the hobbyist and educational markets.

Many companies were supplying micros without the peripherals necessary to make a complete system. The customer was expected to buy the components separately and build-up a system, rather like a stereo enthusiast and, like the stereo enthusiast, he would run into the attendant problems — how to select compatible equipment, and how to store the equipment so that it is not just a mess of boxes and wires.

Equinox was set-up with the aim of supplying complete systems — the computer, VDU, printer and disc drives. It has a staff of 12, including eight technical staff involved in setting-up and testing the equipment before it is sent to customers. It supplies many of its systems through the OEMs, own equipment manufacturers.

This is a term in the computer trade referring to companies which buy equipment from other manufacturers and add other hardware or software to it before selling the complete system to the customer.

Recently, it has often been used to refer to systems houses which buy the hardware at a discount and provide applications programs either in the packages or customer-written software. Equinox has a network of about 30 such dealers around the U.K., particularly in the south, south-west, East Anglia and the north-west.

Its first two products were a system based on the North Star Horizon and the Equinox 300. The North Star Horizon is a

by David Watt

well-known Z-80 system sold by several other suppliers with a maximum 56K of memory and two 5¼in. floppy discs in an integral cabinet. The Equinox 300 is a 16-bit multi-tasking multi-user system using a chip set manufactured by the Western Digital Corporation.

The system features a minimum 48Kbytes of memory with dual floppy discs, up to a maximum 512Kbytes of memory and a variety of hard discs, from a 10Mbyte system with 5Mbytes fixed storage and a 5Mbyte removable cartridge, up to the CDC Phoenix disc which has a 16Mbyte removable cartridge and may have from 16 to 80Mbytes of fixed storage.

In autumn 1979, Equinox announced the IMS 5000 and 8000 systems, and in the summer of 1980, the Equinox 200. As with the 300, the systems may have from 48Kbytes to 512Kbytes of memory, using bank switching, and a range of disc drives for mass storage. The 5000 and 8000 are supplied directly by IMS, Industrial Micro Systems of Orange, California, with 5¼in. mini floppy and 8in. floppy diskettes respectively.

The 5000 may have from one to three disc drives, and the 8000 up to four disc drives. Both types of disc may be supplied in single-density, double-density or double-sided, double-density formats, giving a maximum of 1Mbyte on-line storage with the 5000 and 4Mbytes with the 8000. The Equinox 200 is more suitable for multi-user applications — it is supplied with the same discs as the Equinox 300, the Ampex 448 10Mbyte disc manufactured by the Ampex Corporation, or the CDC Phoenix disc providing from 32 to 96 Mbytes of on-line mass storage. The same processor is used in the 5000 and 8000 and is supplied by IMS.

Equinox supplies a variety of operating systems, program languages and two word-processing packages for use with its systems. For single-user systems, it has the



ubiquitous CP/M from Digital Research Inc, complete with Microsoft MBasic or Basic-80, Fortran-80 and Cobol-80. CIS-Cobol is also available from the British firm, MicroFocus — it is one of the most acclaimed Cobol compilers available for eight-bit microcomputer systems. Wordstar may be used for word-processing applications.

Multi-user systems

Also from Digital Research is MP/M for multi-user systems. It is compatible with CP/M so any of the languages mentioned may be used on a MP/M system, as can Wordstar. Omnix is also a CP/M-compatible multi-user operating system from a U.K. firm, 1500 Systems Ltd. MP/M and Omnix are useful for upgrading to a multi-terminal system where different applications will be run on each terminal, especially when those applications have been developed under CP/M. Unfortunately, MP/M has no means of preventing unauthorised use of files. Many multi-user operating systems allow files for a single user to be grouped together which may then be protected by a password.

From CAP, one of the largest computer

system houses in the country, the CAP-MicroCobol business operating system is available. Various applications packages have been developed to run with MicroCobol, including sales ledger, purchase and nominal ledger, Autoclerk, a file maintenance utility for creating, amending and inspecting business data files, and Autoindex, a database indexing system for fast storage and retrieval of data.

Finally, from MVT Microcomputer Systems Inc is another multi-user, multi-task operating system called MVT-Famos. Famos is an extremely powerful disc operating system for eight-bit microcomputers featuring multi-user security and uses passwords to allow access to selected programs and files.

Memory may be bank-switched up to 512Kbytes with tasks dynamically allocated to individual memory banks. If there is sufficient space, two or more tasks may use the same bank. Applications programs may be written in assembler using ASMZ, a Z-80/8080 macroassembler, or in MVT-Basic. MVT-Basic consists of a re-entrant compiler and run-time module. The compiler produces re-entrant object code, so if several operators are running the same program, only one version of the

program need be loaded in memory.

For the purposes of the review, I examined the Famos operating system on an IMS 8000, with twin double-sided, double-density 8in. diskettes and a Hazeltine 1500 VDU. The benefits of Famos would be more noticeable on the hard-disc Equinox 200 systems, but as the IMS 5000, 8000 and Equinox 200 are compatible with identical processor and memory, it was easier to examine the 8000. I received a good deal of advice in the use of Famos from Microtek Computer Services, an Equinox OEM, based in Orpington, Kent.

Central processor

The central processor unit, CPU, used in the IMS 5000, 8000 and Equinox uses a Z-80A processor chip and is mounted on a 12-slot S-100 motherboard. The systems may be configured with a minimum of 56K and a maximum of 512Kbytes of random access memory, and they will support up to 20 terminals using RS232 serial interfaces. Two parallel ports are provided for devices such as printers.

The IMS systems, the 5000 and 8000 may be provided as desk-top models or suspended beneath a desk-top, to give a work-station configuration. The Equinox 200 series are rack-mounted, again in a cabinet 22in. wide by 32in. deep and 34in. high for the 10Mbyte system and 42in. high for the 32Mbyte system. The standard motherboard for the Equinox 200 has 19 slots giving more space for extra memory and interface boards.

The 200 series may be configured with the Ampex 448 10Mbyte disc with 5Mbytes on a removable cartridge, or the CDC Phoenix drive which has a 16Mbyte removable cartridge and from 16 to 80Mbytes of unformatted fixed disc storage — when formatted the storage is slightly reduced. In addition, floppy discs may be provided with the system as in the smaller models. This is particularly useful for the easy transfer of programs and files — particularly when applications programs are being developed.

Various peripherals

Equinox supplies a variety of other peripherals to complete the system, including Televideo 912C, Hazeltine 1500 or Elbit 1920X VDUs and OKI Microline 80 printer, Texas Instruments 810 150 cps printer, or NEC Spinwriter — a word-processing-quality printer.

Starting the system is a simple matter of switching on the computer and all peripherals and inserting the boot disc in drive 0. The operating system is loaded into memory automatically. There is a spring loaded re-set switch on the front of the cabinet above the red power switch to reload the operating system in the event of a system crash. The power switch also serves as a "power on" indicator and

(continued on next page)

(continued from previous page)

lights-up whenever it is switched-on.

The hard disc drives have additional controls, a stop/start switch, ready light, fault light and write-protect switches for the cartridge and fixed discs. The 10Mbyte drive also has an active light which flashes on and off indicating disc activity.

Once the Famos operating system is loaded the operator may sign on to the system by typing "Q" at the terminal which will cause a message to be displayed indicating the version of Famos being used. No other character will have any effect so it is important to make sure your keyboard is set for upper-case input, or like me, you could find yourself wondering why nothing happens when the "Q" key is pressed. All system commands must be typed in upper-case or they will be rejected by Famos.

Famos may be supplied without user-accounting for single-user systems, in which case the system will display SSREADY, which is the standard prompt indicating the system is ready to execute a task. However, with the user-accounting version, a user name, up to eight characters, must now be entered followed by the password associated with the user name. The password is not echoed on the screen when it is typed-in, making it harder for unauthorised people to learn passwords and gain access to the system.

Restricting access

Besides restricting access to the system, user-accounting also permits file access for a user to be restricted to the files in his own account. File names may be up to 15 characters long. When user-accounting is in operation, all file references made by the user have a three-character prefix tagged on to them automatically — the prefix is the first three characters of the user's name.

It is invisible to the user except when using certain system commands, such as MAP which displays the list of files on a disc and it means if two users specify the same file name, they will access two different files unless they have the same first three characters in their user names.

File-name prefixing is optional. If it is disabled, any user can access any file. Also, file-name prefixing does not occur if the user name begins with "X", or the file name begins with "C". User names beginning with "X" are designated as system accounts and can access any file on the system and similarly file names beginning with the letter "C" are designated as common files which may be accessed by any user.

In addition to user account passwords, another level of security is provided by allowing individual files to be protected by passwords. Passwords are specified by putting a comma and the password after the name of the file — the whole string is up to 15 characters long. The passwords

are not normally displayed with the file names, but whenever a file name is specified for processing, the password must be specified as well.

There are four types of files handled by Famos, types A, B, C and E. Type A is for print spool files, data files or program source files, type B indicates compiled Basic programs, type C indicates assembler programs and type E, temporary edit files created by Word-flow, the MVT word-processing system.

The device on which a file resides may be specified by prefixing the file name with a colon, followed by a unit number. Up to 16 units may be referenced in this way. Unit numbers may be in the range 0 to 9 or A to O with the numbers 1 to 9 being equivalent to A to I. Devices may be random, i.e., discs, or serial such as printers. Serial devices are indicated by using the special character "<" in place of the file name in the file specification.

When the operator has signed on to the system, his terminal is under control of Superselector, the re-entrant command processor. This issues the prompt SSREADY and waits for the operator to input a command. Superselector allows the user to queue an assembler program as a task for execution, suspend a task, resume a task, resume a task attached to the terminal so that the task may display messages or receive input from the terminal, end a task deleting it from the system, or end all tasks currently initiated by the terminal and sign the user off the system.

In addition to these commands, various system functions which are part of the operating system may be executed just by typing the name of the required function.

Sample hardware prices

1. Horizon System. 56K RAM. two 5¼in. double-sided, double-density disc drives Hazeltine 1500 VDU OKI Microline 80 Printer	£ 4,200
2. As for 1 but with Elbit 1920X VDU NEC Spinwriter	£ 5,450
3. IMS 5000 64K RAM three 5¼in. double-sided, double-density disc drives Elbit VDU NEC Spinwriter	£ 5,650
4. IMS 8000 64K RAM two 8in. double-sided, double-density disc drives Elbit VDU NEC Spinwriter	£ 5,900
5. Equinox 200-10 64K RAM 10Mbyte disc drive Elbit VDU Texas 810 150 cps printer	£ 9,750
6. As five but with 192K RAM four Elbit VDUs one Texas printer one NEC Spinwriter	£15,500
7. Equinox 200-32 256K RAM six Elbit VDUs two printers	£20,500

These functions allow the user to create, delete, copy and merge files, display files and file names, edit, compile and run Basic source files, display various system statistics and control the operation of the system.

Famos does not allow the operator to type-ahead — that is to continue entering commands or data while the system is processing previous commands. I found this rather inconvenient. If one attempts to type-in data before the system is ready, the input is rejected and the terminal makes a beep.

The Superselector will accept a string of commands and parameters input in a single line of up to 66 characters. Each command must be separated by a "/", parameters by "[", and the first parameter for a command must be preceded by a dot.

Command sequence

This is useful for inputting sequences of commands which might take a comparatively long time to execute and for which all the required parameters are known; for instance, when compiling and running a Basic program. Alternatively, new system functions may be set-up which consist of a set of the existing commands, or systems programmers can create entirely new system functions using existing commands.

A special editor, MCOMM, is used to create the function in a type C file. The commands to execute the function are input as described for command lines but only one command and its parameters may be input on each line.

Although these facilities, particularly the ability to set-up special functions, are useful, I found it was very easy to forget to type a dot before the first parameter of a command with the result that the system misinterpreted the command. With type-ahead, the operator does not have to learn any special characters for inputting the commands.

Some special control codes can be used to correct commands before they are input to the system. Control "X" cancels all input on the line as a new command can be typed. Control "G" and Control "H" move the cursor right and left respectively so that characters can be changed by positioning the cursor correctly and typing the new character over the existing character. Characters can be inserted by using control "I".

Control "X" does not cause the cancelled input to be cleared from the screen, or give any other visual indication that it has been entered. Control "I" causes the character under the cursor to be duplicated and the display is not changed until the cursor is moved along, so it can be confusing to use both these characters.

There are two other special characters used by Famos. Control "T" is used to generate an interrupt when a program is executing a Wait statement, and ESCAPE

which may be used to suspend a task and return to the Superselector. The task may then be resumed or terminated by the Superselector.

If the task requires no operator intervention and does not require any operator input, it may be suspended after being initiated by pressing ESCAPE, and then resumed. This frees the terminal for use by another task.

Another facility available only with user-accounting versions of Famos is batch processing. Programs may be run under control of the batch processor which accepts commands and data from a special file called job file, as though they were being typed in by an operator.

Job files may contain job control lines or terminal input lines. Job control lines allow terminal output to be routed to a special file or device, user-account names and passwords to be specified, terminal input to be echoed on the terminal output file, and for the current task to wait until its sub-tasks are complete.

Terminal-input lines are lines of data to be input to the programs being executed by the batch processor and appear exactly as they would if typed by an operator. Batch-processing tasks are controlled by the batch monitor which is a special program which is treated by Famos as a dummy user. That is why it is available only with user-accounting versions. The batch monitor maintains a queue of tasks awaiting execution which can be examined and manipulated by a batch control program.

Job displayed

BCONTROL allows the operator to display the jobs awaiting execution and the current job being executed, to abort the current job, or all jobs, to delete the current job-file name and to bump jobs up the queue so they will be executed sooner.

Batch processing is a very powerful facility because it allows non-urgent tasks to be queued for processing as required, freeing the terminals to be available for input and enquiry and other tasks requiring a good deal of operator intervention.

Efamos, the E stands for extended memory, allows systems to be configured with up to 512Kbytes of random access memory. The memory is allocated in 32Kbyte banks — the first bank is used by the operating system and remaining banks are available to user tasks.

Terminals are assigned to banks either explicitly via a bank-assignment table, or banks may be allocated dynamically, in which case a user is assigned to the bank with the least number of other users. The bank assignments can be changed by using the ASSIGNB system command. They are not fixed when the system is initially generated as they are in many other operating systems.

At present only Basic and assembler are available for writing application pro-



grams, although Cobol is reputedly under development. MVT-Basic consists of a re-entrant run-time package and compiler. The compiler produces semi-compiled object code, which also re-entrant. Using a compiled language, it is less easy to develop and test programs than using an interpreter, but a compiler usually produces more efficient code, so that programs execute more quickly. MVT-Basic certainly seems to be acceptably fast. Except in the case of transcendental functions like SIN, COS and LOG.

The review system performed approximately 83 operations per minute of a simple loop containing a SIN and a LOG function. I asked Paul Ringer at Microtek about it and he said MVT did not write them very efficiently because an assumption was made that they are not used very frequently in business data processing. That is true, but when they are used, the same calculation may need to be done on hundreds of records in a file. Microtek solved this by designing its own routines for the function it needed.

The Basic contains all the usual verbs and expressions. Variable names may be up to eight characters long and string variables up to 55 bytes long. The size may be defined by the Size statement at the beginning of the program. It is good practice to define the size of all string variables used in a program. Otherwise, strings will default to a size of 80 bytes which is wasteful of program space.

The precision of floating-point variables is determined when the system is generated. The default size is six bytes which allows numbers to be held to 10 decimal digits of accuracy. Multi-dimensional string and numeric variable arrays are supported by Famos. There does not appear to be a limit on the number of dimensions which may be specified but the total number of elements may not exceed 255.

There are two methods for input from a terminal, the Input statement and the GBYTE function. The Input statement

allows one or more variables to be input separated by single spaces. Commas are not treated as delimiters and may be included in string variables. GBYTE allows a program to receive the next character input from the keyboard. There is no Input Line statement in MVT-Basic to input a complete line of data terminated by line feed or carriage return.

Fixed-length strings may be input using the FLD function which allows spaces to be input as part of the string. If a string longer than the length specified is typed, the string will be truncated. If the string is too short, the input will be rejected and the program will re-execute the whole Input statement — as it does in the event of any error.

Input statement

In general, I found the Input statement rather inflexible, particularly for input of string data. I believe it is better to use the GBYTE function and the FLD function would have been much more useful if it accepted short strings.

The Print and Print Using statements work in a similar fashion to M-Basic and other versions. The Print Using statement allows data to be output in specific formats and is also similar to M-Basic. The Tab function may be used for positioning the cursor anywhere on the screen and may have one argument specifying the next print position on the current line, or two arguments specifying a line and column position, which is very useful for inputting or displaying screen formatted data.

Basic has facilities for handling files in two ways. Type I access is primarily for sequential ASCII files, while type II, internal format, is used for mainly random access data files, although files can, in fact, be accessed by either method. ASCII files are used for print spool files or job files to be used in batch processing and are treated in a similar fashion to

(continued on page 63)

SIMPLICITY & EFFICIENCY

From a single system to a network supporting 250 users

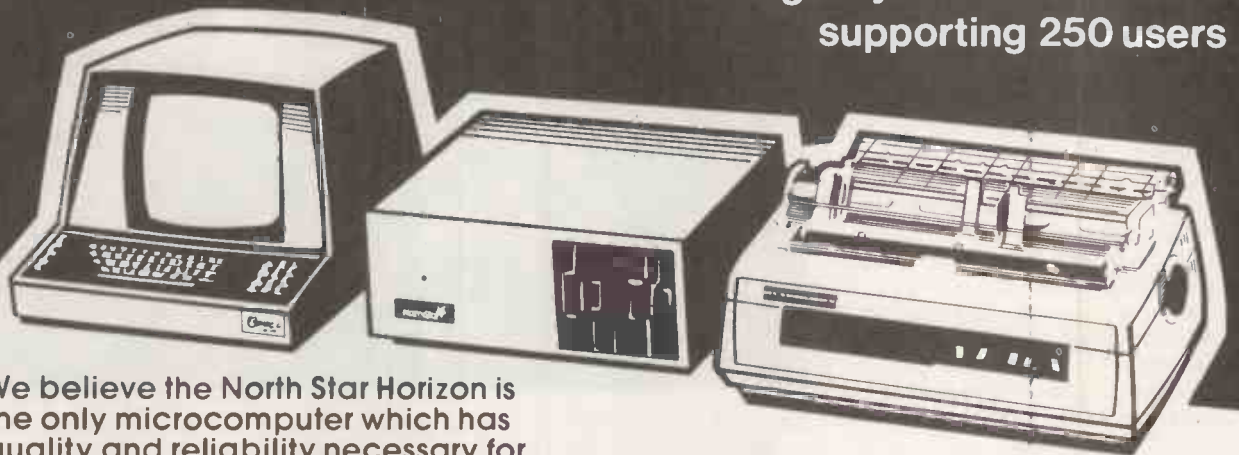

We believe the North Star Horizon is the only microcomputer which has quality and reliability necessary for the serious small business user. We supply the Horizon with a Hazeltine 1420 terminal and an Epson MX80 Dot Matrix printer or optionally with a Vulcra-Craig terminal and Diablo 630 letter quality printer.

ACCOUNTS

Complete accounting software for the above system suitable for the small manufacturing company. It is characterised by extreme ease of use and security of data. It uses only three disks thus preventing all that confusion typical of so many accounts systems. The software is designed to be very fast when interacting with the user. Included in the package are facilities for fast search, ledger inspection, aged debt analysis and management accounting summary. The latter provides a complete breakdown of overhead expenditure and all trading parameters and is an

extremely powerful tool for management accounting in today's small business. Passwords and other safeguards make it virtually impossible to make mistakes one example of which is the back up facility in which it is impossible to accidentally copy from the back up disk to the working disk.

INVENTORY CONTROL

This program links to the accounts system through a special sales module so that sales from stock are automatically entered into the accounts. You can even sell directly from stock generating an invoice on the spot and even inspect your stock whilst in the middle of generating an invoice. The system gives warnings of low stock levels notifying re-order points and will also analyse sales by stock item giving total margins on each item. This extremely powerful system is ideal for companies or shops selling from stock.

NETWORKING

Office Administration, Data logging and Computer Aided Manufacture (CAM) all tied together with this Z80 based micro network utilising low cost hardware and proven software. This can be built up from a stand alone word processing system at £2,800 to full network systems starting from £7,750. Government assistance available for CAM applications. Free feasibility studies undertaken by MAP consultants. Contact **Peter Krueger** for more information.

IA Systems (Intelligent Artefacts)
Cambridge Road, Orwell,
Royston, Hertfordshire
Tel: (022020) 689



Please send me details of the IA Networking System

Name

Address

Company

Position

IA Systems, Cambridge Road,
Orwell, Royston, Hertfordshire.
Tel: (022020) 689

PC5/81

• Circle No. 157

(continued from page 61)

the terminal input/output methods.

MVT-Basic treats type I files as containing variable length fields delimited by spaces or "Escape" characters. Alternatively, fixed length fields can be referenced using the FLD function.

For type II files, data is input using the Get statement and output using the Put statement. Both statements have the same format consisting of file number, record size and record number parameters followed by a variable list.

If the record size parameter is zero, the record number parameter may be used to move the file pointer, which indicates the current position in the file, backwards or forwards a specified number of bytes. Data is held on the file in a fixed format according to type.

Numeric variables occupy six bytes and string variables the length of the string as defined by the Size statement plus two bytes. There appear to be no restrictions on having variable length records in a file but obviously one would have to be very careful how one accesses such a file so as to keep track of the file pointer.

Disc-file integrity is maintained by the operating system. Allocation of file storage space is managed by using a bit-map. That is common to many operating systems, but Famos keeps the bit-map constantly up-to-date. When Famos needs to refer to the bit-map, it is read into a special buffer. It is amended as necessary and then written out immediately. That ensures the bit-map always reflects the state of the disc, although it obviously will slow file accessing.

Bit-map update

The time taken to write 100 256byte records on the IMS 8000 system was 50 seconds, compared with five seconds to read the same records. Many other systems, particularly those designed to use hard discs, hold the bit-map in memory continually and only update the map on the disc just prior to the disc being removed from the system or the system being shut-down.

If the bit-map is not written back before a disc is removed, in the event of a system crash the bit-map is not updated and will not indicate the true state of the disc. If the bit-map is not recovered at the earliest opportunity, data can be lost or corrupted. The file system also prevents two tasks accessing the same record simultaneously by automatically providing record lock-outs.

The physical block size used for disc file accessing is 256bytes for both floppy and hard discs. However, logical records may be any size from one to 65,536bytes. Lock-outs operate on physical blocks, so if there are multiple records to each block in a particular file and one record is being accessed in a particular block, other tasks will be prevented from accessing any records in the block until the first record is

released. For cases where records span blocks, Famos provides a method for setting long locks.

GETR and PUTR should be used instead of Get and Put for records which span blocks. These statements control the setting of long locks. There is also a statement ULOCK which forces the removal of long locks from a file although it does not affect the normal block locks.

There are two functions for use with either type of file: POSI allows the pro-

Software Prices	
MVT-Famos run-time system	£ 475
MVT-Famos Development system including Wordflow	£ 1,350
MVT-Wordflow	£ 250
CAP-MicroCobol	£ 2,650
CP/M	£ 95
MP/M	£ 395
Omnix	£ 495

gram to position the file pointer to the start of a specified block, and CHGF allows a file to be expanded or contracted.

Both assembler and Basic subroutines may be called by a Basic program. The format for Call is similar in both cases. A control code may be specified in the call. For assembler routines the control code just allows the program to load, retain, release or call routines, as required.

For Basic subroutine calls, the control code allows the routine to be executed and then return to the calling program, or to act like the Chain statement in most other versions of Basic, which transfers control to the new module releasing the calling program. The Call statement for Basic subroutines also has a parameter specifying which variables are to be used for passing values to the subroutine and which are receiving return values.

The Basic subroutine may then have two special statements, a PARM statement listing the variables to receive data from the calling program, and a Return statement listing variables to be returned to the calling program. This last is different from the normal internal subroutine Return statement.

This facility is very powerful — particularly in being able to call Basic subroutines. Despite the format being similar for Basic or assembler calls, there is no danger of confusing the two because the control code for assembler calls is in the range 0 to 4, while for Basic calls, it must be 10 or 11.

For indexed-sequential file access, an assembler program called ISM2 is provided with Famos. It uses a hash index table to locate keys which gives very fast access times when keys are random. The hash index table is held in a key file together with the keys. ISM2 uses a special algorithm to calculate hash values. Each key in the file is pointed to by an entry in the hash index table.

That means the keys can normally be found by using only two reads of the key file. This may be compared to tree-structured index files where keys are

stored in successive levels, each level indicating the position in the level below where the key might be found, until one arrives at the lowest level where the keys point to the actual data file.

In this type of structure, it normally requires as many reads as there are index levels to locate the data record. Hash index tables are fine unless there are several keys with the same hash value, when they can become inefficient.

Since new keys are added to the end of the key file rather than being inserted in order, it can be inefficient to produce reports in key order. To sort key files into order, a utility called SUPSORT has been provided. It is claimed to be very fast. The Basic manual quotes 20,000 to 50,000 keys per hour on a hard disc, depending on the ordering of the file and key length.

There is a comprehensive set of development tools for producing assembler programs, including a macro assembler ASMZ, debugging program DBUG, and linkage editor LKED. ASMZ is compatible with 8080 or Z-80 code. DBUG allows the programmer to test assembler programs by setting breakpoints, display and set memory contents, and read and writes data to disc or the terminal.

Word processor

There is also a word-processing package available for use with Famos. Called MVT-Wordflow, it consists of a screen editor and a print program. The editor allows up to three document files to be processed in the same session. Wordflow is very versatile — it features commands for setting rulers, cut and paste of text from one file to another, or within the same file, insertion of control codes to set underlining, boldface, printing of superscripts or subscripts.

Composite characters can also be created and there is a facility for listing processing. Rulers allow the setting of top, bottom, left and right margins, paragraph and word-wrap indenting. Also tabulators can be set which allow left- or right-alignment, or text strings can be aligned on a particular character. So columns of numbers can be printed with the numbers all aligned on the decimal point.

I found the editing commands themselves relatively easy to use, although most of the commands required two control codes to be entered, rather than one. For instance Control D Control C is used to delete a character, and Control V Control B to go to the start of the file.

Some commands are even more complex, but this is not a criticism as they are for special operations like search and replace, or for specifying fields to be inserted when performing list processing. As text is entered or edited, words are often split on the right margin and the display becomes confusing to read. If you want to see the text correctly formatted, Control

(continued on next page)

(continued from previous page)

X is the key which must be pressed.

The output program is used to bring the document inserting fields like the date and data from list processing files which must be in a special format.

The documentation provided with Famos was all produced by MVT-Micro-computer Systems. It consisted of a Famos Users' Manual, Wordflow Users' Manual, Program Development Manual, a Basic Programmers' Guide and a MVT-ASMZ Programmers' Manual. On the whole, they were comprehensive and relatively easy to find one's way round, although the programming manuals were not as easy to follow as the user manuals. I noticed some omissions, particularly in the Basic Manual.

The format for the use of GETR and PUTR was not given, for instance. Also some of the manuals would have benefited from the inclusion of indexes at the back — especially the Program Development Manual and the ASMZ Manual. Also, the Wordflow manual did not have an index, although it had useful lists of all the commands.

Operational configuration

So that I could see an Equinox 200 in operation, Microtek introduced me to one of its customers, Chemical Bank International which has a 32Mbyte system with five Elbit VDUs, a Tally 1602 serial printer and floppy discs for data transfer to an IBM system 32.

The system has 224Kbytes of RAM, 32K for use with each VDU, 32K for use by the system and 32K for use by the batch monitor. Four VDUs are used for enquiries and one for entering file updates.

The system is designed to handle trading in Eurobonds, which are types of securities issued by large multi-national corporations and traded in by banks and other financial institutions. Like other forms of dealing in securities or commodities, this involves a good deal of intense activity at certain times of the day.

During peak dealing times, there must be no appreciable degradation in response to enquiries. Up to 1,000 securities may be held on the system, which is designed to handle up to 350 deals per day, and a record of the previous 28 days dealings is maintained on the history-monthly file.

In a demonstration of the system capabilities selecting all deals for a customer in the past month, it took 21 seconds to locate and display 12 records from 9,800 on the history file.

At about 5 pm each day, the end-of-day program is run to update the daily profit and loss fields, and up to four yields for each security on file. This process takes an average of 12 seconds per security. The calculation of yields, in particular, is very complex as the method used is an iterative process requiring successive approximations to reach the final value.

The technique is to make an initial guess at the answer to the problem and use this value to calculate a new value which is closer to the required result. When the results of two successive approximations are close enough together, within some margin of error, the last value is taken as the correct result. The end-of-day program also updates the history-monthly file with the day's dealings, prints various daily reports and performs the file security copying.

It is a 32Mbyte system because Chemical Bank International required the faster response available, even though it has only 4Mbytes of data. Therefore, it has all its files on the fixed disc and uses the cartridge to copy data.

All that is run under the control of the batch monitor. The bank is lucky in having a night shift operating its main-frame who switch-off the Equinox system when the end-of-day processing is finished, although there is no reason why computers should not be left on 24 hours a day. Indeed, in many cases, leaving a computer on continuously can improve the life of a system.

The bank decided to buy the Equinox 11 months ago, when it had already been waiting six months for an IBM system 38. At that time, it knew there was still a six-month wait for the IBM system and business pressures forced it to look at microcomputer systems. The Bank looked at several systems, including Cromemco, Zilog and DEC 11/23 systems.

The Equinox was the only system which met its criteria, which were to have a multi-user system with a Basic compiler. Having decided on using Equinox equipment in June, 1980 the Bank bought an IMS 8000 system complete with applications package in August. In September, 1980, the Bank decided to upgrade to a hard-disc system and re-designed applications software, which it received on November 15. The staff were very pleased with the Equinox and with Microtek's service and support, and are considering enhancing the system to link into the Geisco time-sharing network.

Conclusions

- Equinox has a wide range of systems, ranging from small, single-user systems to multi-terminal, hard-disc systems.

- The Equinox 200 systems are compatible with the IMS 5000 and 8000 because they use the same processor. With a maximum configuration of 20 terminals, two printers, up to 96Mbytes of hard-disc mass storage and, say, 256Kbytes of memory, which allows 32K for each terminal plus 32 for the operating system and 32 for a batch processor, it is a very powerful system.

- I believe there have been some problems with the S-100 bus on the hard-disc systems recently, but they have since been solved.

- Equinox also supplies a wide range of

operating systems and support software to use with its hardware. None of the software is actually developed by Equinox.

- Both the CAP-MicroCobol business operating system, and MVT-Famos are suitable for multi-user business systems. MP/M can also be used but has no file-protection or security features as standard, and neither does it have automatic record lock-outs; these facilities would have to be built-in by the programmer.

- MicroCobol seems rather expensive compared to the other operating systems on offer.

- Famos is an extremely powerful and versatile operating system well suited to multi-user systems; the user accounting security and file security systems are very useful: Famos has been designed to maintain file integrity as much as possible while allowing multi-user access to files and dynamic file extension and contraction.

- The batch-processing and multi-task handling features of Famos are both extremely useful and I would advise having the user-accounting version of Famos even with a single-terminal system so that it is possible to use batch processing; also, the single-user version has no protection against unauthorised people using the system.

- MVT-Basic seems to be a reasonable implementation of Basic. Being compiled, MVT-Basic programs run faster than interpreted programs. Transcendental functions are rather slow but they are rarely used in business data processing.

- I found terminal input awkward to use in Basic; for many applications, the GBYTE function looks more appropriate than the INPUT statement. I think an Input Line command would have been a useful addition.

- File input/output is very flexible but it must be used with caution as ASCII file access and internal format can be used on the same file and also record or byte positioning.

- Because of the points described, Famos is not a system for the inexperienced programmer: if you are an inexperienced user who just requires a business system it is best to have the applications programs, or package, provided by an OEM systems house. That is true of most interactive multi-user systems because of the care which must be taken to prevent users updating the same record at the same time, and also to allow those users adequate response. To a large extent, Famos prevents the first problem by using the automatic record locks, but it can still occur if PUTR and GETR are not used for records which overlap blocks.

- Wordflow is a useful word-processing package, but I did not like the double-character control codes, and I would have preferred to see a correct display at all times. However, it is a powerful package. The list processing facility is particularly useful for producing multiple copies of letters with different addresses. □

Multi
Variable

Task ... System Software for Micros

*Multi-user Micro Power through
FAMOS™
from MVT Microcomputer Systems, Inc.*

THE ONLY 8080/Z80 MULTI-USER SYSTEM FOR HIGH END-USER PRODUCTIVITY

RELIABILITY - Owing to efficient design and long (3 year) period of stabilization.

DATA BASE INTEGRITY - FAMOS file system is only micro program supporting automatic file system integrity maintenance. File record lockouts are automatically provided by the file system.

DEVICE INDEPENDENCE - Table controlled random and serial file I/O. One microcomputer can simultaneously support several hard disks, floppy disks, drum storage and even core memory, all operating synchronously.

FLEXIBLE MEMORY MANAGEMENT - Bank select on fixed boundaries (16 and 32 KBytes) and extended address mapped memory. Up to 3 MBytes of memory can be used with each user having his own 32 KByte bank.

THROUGHPUT - Optimizing BASIC compiler and fast run-time provide unmatched throughput in a multi-user environment. . . . 6-30 times faster than competing systems.

EFFICIENT LARGE DATA BASE SUPPORT - Multiple key ISAM provides rapid access to records in files to 16 MBytes. Random files can be any size.

ENVIRONMENTAL FLEXIBILITY - FAMOS is the only software system supporting a true batch monitor. Any combination of foreground, background and interactive operations are simultaneously supported. This includes concurrent data and word processing, program development and communications.

USER ACCOUNTING WITH MULTI-USER FILE SECURITY - File protection is provided through: passwords, filename prefixing and code protected flag protects.

FAMOS, the logical system of choice:

By the Manufacturer . . . prolongs sales life for Z80 based systems. FAMOS 6MHZ system will outperform 16 bit systems.

By the System House . . . lower maintenance, vertical customer base, migration path (16 bit run-time system will be available when timely).

By the End-User . . . high productivity, lower cost per work station, no obsolescence, minimal down time.

SINGLE SOURCE SYSTEM SOFTWARE . . . Multi-tasking DOS, Optimizing BASIC Compiler, 8080/Z80 macro assembler, Relocating Linkage Editor, Multi-user word processing system, List processing system, Disk SORTs, Core SORT, User Accounting, Multi-key ISAM, BASIC DEBUG facility, Diagnostic routines, Spooler, Forms facility, BATCH processor, Command line interpreter, BDE utility, Communication software, BASIC SYSQ utility, Over 225 system routines, variables and utilities . . . and more.

HARDWARE SUPPORTED . . . CROMEMCO, IBC, IMS 5000, IMS 8000, NCR 8130, NCR 8140, PCC2000, MICROBYTE, ARTEC, SSM, SYSTEMS GROUP and others. Hard disk subsystems include KONAN SMC-100, XCOMP and Century Data.

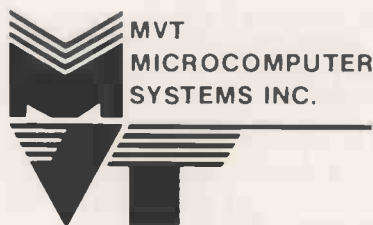

SALES AND SUPPORT IN UK:

Microtek Computer Services (Agents)

50 Chislehurst Road
Orpington, Kent BR5 0DJ
Tel. Orpington 26803

IMS Dealers

Sharp's cut-above-average MZ-80K hardware

The Sharp MZ-80K computer was first marketed in the U.K. in 1979; before that, it had been available only as a kit in Japan. In the 18 months the machine has been on sale in Britain, the price for a model equipped with 20K RAM has fallen substantially to £380.

THE SHARP MZ-80K is advertised widely, often with an emphasis on its suitability for business or office use. It is also used for laboratory and industrial process control by firms such as 3D Digital Design and Development. Three units are available as part of the MZ-80K package; an input/output interface unit, a dual floppy disc drive and a tractor-feed dot-matrix printer.

The commercial reputation of Japanese firms is based very largely on often clever precision engineering and high-quality

by John Dawson

control during production. The ability of the Japanese to write ingenious software is, however, less certain.

The high-quality engineering in, for example, the MZ-80K double-track disc drives may suggest that the Japanese have sought hardware solutions to compensate for their software failings.

The dimensions, weights and power consumption for the review equipment are set out in table 1. The review MZ-80K had been fitted with a Xtal CP/M adaptation. The machine consists of four printed circuit boards: the main CPU board, tape recorder, keyboard, and visual display unit/audio frequency amplifier. The CPU board is the largest and is mounted inside the base of the steel case with the other boards mounted on the upper section of the case.

The power supply is enclosed within a ventilated metal case and is mounted beside the CPU board. Power is supplied through a two-pin connector which is standard for all the units in the system at the rear of the computer and there is a second opening, with a screwed metal cover, which allows access to a 50-pin Scotchflex connector. The CPU bus is brought out to the connector and is the sole signal input and output pathway to the computer — the 50 lines are shown diagrammatically in figure 1.

The MZ-80K has a three-octave sound generator and a real-time clock which is re-set when the machine is switched-on. There are pre-set controls for the VDU and the volume of the internal loud-speaker mounted on the front edge of the printed circuit board below the VDU. The CPU board has vacant connections for a re-set switch.

The steel case of the computer is strongly constructed with a piano hinge connecting the upper and lower sections which are normally secured by four screws. The strut supporting the upper section of the computer when it is opened has a retaining thumbscrew on the lower leg which can be screwed-in to prevent the

	Dimensions			Weight
MZ-80K	41W	47D	28H	13kg.
MZ-80I/O	20	32	13	5
MZ-80FD	20	32	20	7.9
MZ-80P3	41	38	19	10

Software serial numbers	
Sharp/Xtal monitor	SP 1002
Sharp tape Basic	SP 5025
Sharp disc Basic	SP 6015
Xtal CP/M	Version 2.21
Xtal CBasic	Version 2.061

Dimensions are quoted in centimeters and exclude cable-bending radii. Total power consumption for the four units is given as 215Watts.

Table 1. Equipment dimensions.

upper section of the case collapsing accidentally.

The visual display unit produces a white-on-black image 40 characters wide by 25 lines deep in an eight-by-eight format. A wide range of graphics characters are available including electronic symbols for drawing circuit diagrams on screen and a good number of games and general-purpose shapes. The lower-case letters have true descenders and there is a pseudo-high-resolution graphics capability which will display 50 by 80 pixels.

Both the stability and definition of the display are excellent, although there was some pin-cushion distortion in the picture symmetry on the review machine, which meant that the last six characters on the right-hand side of the bottom line were almost illegible because they had curved off the screen.

This fault is not apparent on two other newer MZ-80K machines where the picture symmetry is good — good enough for you to take direct photographs of the screen and use them as slides in lectures.

The cassette tape recorder in the MZ-80K uses a pulse-width modulation recording technique and transfers information at 1,200 bits per second. A mechanical tape counter is fitted and the

recorder is controlled both by mechanical keys and the system software.

The tape counter is fitted in the cassette recorder and programs or data on the cassette tape can be located accurately and reasonably quickly using the fast forward and rewind controls with the counter. The data-transfer rate for the recorder is impressive — it allows the 14 kilobyte Sharp Basic tape to be loaded in about 1.5 minutes.

On microcomputers, the keyboard and the visual display unit are the interface between machine and user. The level of ambient lighting in an office environment, the reflections from a VDU screen and the angle at which it slopes, the ability to separate the keyboard from the screen so that a typist or operator can be comfortable are all important considerations in designing a machine which will allow a user to operate it for long periods without fatigue or unnecessary strain.

Similarly, a considerable amount of work has been done on the ergonomics of keyboard design and this is apparent now in both computers and word processors from firms like IBM and Logica at one end of the scale to more modest machines such as the Tandy TRS-80 at the other. Those who use keyboards as part of their work develop strong preferences and this allows room for variations such as the extended front on the IBM 5120 machine on which an operator can rest the palm of his hand. These variations are made, however, within well-defined limits of good design.

The keyboard of the MZ-80K is markedly at variance with the rest of the machine, is outside any concepts of good design and surely can be neither intended nor used for serious typing. The spacing of the keys is the same as an ordinary offices typewriter — 0.75in. from key centre to key centre — but the relative positions of the keys are non-standard although the board uses a normal QWERTY lay-out.

In particular, the position normally occupied by the space bar contains the cursor control, carriage return and insert/delete key in addition to a small space key. The key-tops are transparent plastic caps marked with graphics characters as well as the alpha-numeric characters. The main alpha-numeric markings do not stand out clearly enough which makes identification of a particular key more difficult.

Under the original Sharp monitor, the keyboard also has non-standard functions. Lower-case letters are produced after the SML/CAP key has been pressed but the comma and full stop keys then produce characters with umlaut accents. This is an infuriating idio-



The Sharp MZ-80K.

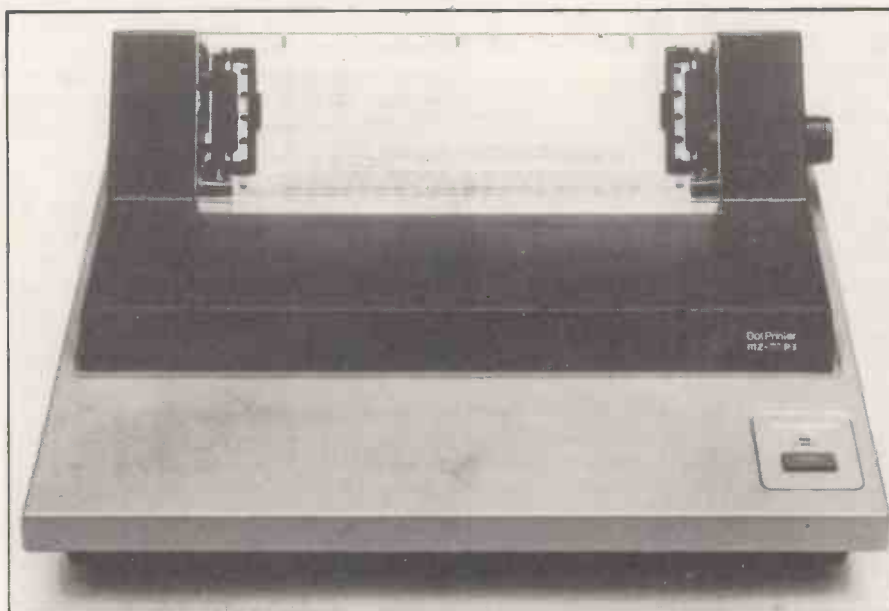

Sharp's MZ-80 P3 dot-matrix printer.

syncrasy whenever text is being entered.

The MZ-80P3 printer is a tractor-fed dot-matrix printer capable of handling paper widths from four to 10in. The normal characters are printed in a six-by-seven dot format and there are no descenders on lower-case letters. The printer will produce double-width characters in a 12-by-seven format and the print-head is driven across the paper by a peg in a slotted drum. This has the important consequence that the print-head must complete a full line's travel however short the line printed. In other words, a line-feed character still requires

the print head to traverse the full width of the paper and return.

The print-head prints in one direction only and will produce 80 characters per line on 10in. paper. The printer accepts parallel eight-bit ASCII data and will produce 255 ASCII and graphics characters. There is an 80-character print buffer inside the MZ-80P3 and it is possible to lose the last line of print under some circumstances in which case it may be output, disconcertingly, at the top of the next print run.

The MZ-80FD floppy disc unit contains two 5¼in. single-sided, single-density,

double-track disc drives, storing 143 kilobytes per disc. The disc drive mechanisms are very smooth and well made. The 70-track format is unusual and non-standard in the U.K. and means that software which might otherwise be regarded as standard, e.g., CP/M-based programs, is not directly transportable from other machines to the MZ-80K.

Like all the peripheral units forming part of the MZ-80K system, the MZ-80 I/O unit is housed in a smart steel case, containing a five-slot mother board and a discrete power supply unit. The mother board uses double-sided connectors with 30 pins on each side. The pitch of the connector appears to be 0.125in. — a non-U.K. standard. The I/O interface unit is connected to the MZ-80K by approximately 18in. of shielded 50-way ribbon cable.

Part of the MZ-80K configuration is a real-time clock which starts counting from zero when the machine is switched-on. The clock can be synchronised with GMT and could be used to control external devices. If personal computers are to continue their present penetration into the home market, it will be because they are seen to have a useful function around the house.

Machine durability

The computer will have to run continuously — with tighter electrical-engineering and safety requirements — if, for example, it is to operate a burglar alarm, deal with incoming telephone calls, process the family budget, and act as a facsimile transceiver for letters and mail-order catalogues. The MZ-80K and its peripherals ran continuously for three days during the review period without signs of overheating or distress in any of the units.

Software has two important parts; the program itself and the accompanying documentation. Good documentation is not the myth it often seems to be and companies such as Hewlett-Packard, IBM and Rockwell produce excellent written explanations to support their products. The U.K. armed forces also understand the importance of clear, simple and concise English in their instruction manuals.

Comment on the CP/M manuals supplied with the Xtal adaptation for the Sharp should start on a long rising note of hysteria and frustration. The abundance of jargon and virtual absence of worked examples throughout the CP/M documentation made the system almost wholly obscure for a user without access to a source of CP/M folklore.

Moreover, the CP/M 2.21 version fitted to the MZ-80K is still cluttered with sediment from the past. CP/M originated, for example, with machines which used Teletypes for input and output. Consequently, the delete key on the Sharp repeats characters entered on a line in

(continued on next page)

(continued from previous page)

reverse order, erasing them from the line memory at the same time. To correct a mistyped letter in the word MUSACBOX, you must either delete the whole line or delete and type the following:

MUSACBOXOBCAICBOX

which is then entered as MUSICBOX. The Research Machines CP/M version 1.4 has a patch which simply erases a letter when the delete key is pressed and I wonder how this anachronism has survived into the 2.21 version offered by Xtal.

More seriously, the assembler/disassembler included on the CP/M disc is an 8080-based program which demands that the user should learn a new set of

Figure 2.

```

DDT VERS 2.2
?
-L 1200
 1200 CALL 18DA
 1203 MVI C,01
 1205 CALL 18C9
 1208 LXI B,1DF7
 120B DAD B
 120C SHLD 103F
 120F NOP
 1210 LXI H,06A4
 1213 MVI A,FF
 1215 XRA M
 1216 MOV M,A
-L
 1217 JMP 0785
 121A NOP
 121B NOP
 121C NOP
 121D NOP
 121E NOP
 121F NOP
 1220 ??= 20
 1221 SUB B
 1222 NOP
 1223 MOV B,B
-L
 1224 NOP
 1225 ??= 08
 1226 LXI H,9210
 1229 ??= 10
 122A LXI H,4212
 122D MOV C,B
 122E NOP
 122F DAD B
 1230 ??= 10
 1231 STAX B
 1232 MOV B,B

```

mnemonics, also denying the use of the additional Z-80 specific instructions, many of which are particularly powerful. When the disassembler is used to list Z-80 code, it produces the results shown in figure 2 in which the double question marks presumably indicate instructions beyond the scope of the disassembler.

Research Machines, once again, has written a Z-80 assembler called ZASM for its own CP/M package. I found the editor program difficult to use and, when I was unable to make one instruction perform any function at all, the manual compounded my confusion.

One good feature in the CP/M adaptation to the MZ-80K made by Xtal is its modest claim to have made "what we consider to be some standardisations and improvements on the . . . keyboard". The SML/CAP key toggles between upper- and lower-case and lower-case characters are given their normal ASCII value. Full stops and commas can be typed normally in both upper- and lower-case mode and, as far as is possible by altering software, the keyboard is greatly improved when the machine is running CP/M.

Xtal supplies the Rodney Zaks CP/M handbook with Xtal CP/M discs and manuals. Although the book provides an alphabetic list of CP/M commands presented consistently, the text is often a paraphrase of the original manuals rather than a complementary overview and introduction to the system.

Tape Basic

The Sharp tape Basic is supplied with the machine so the main question in a review must be whether the additional cost of the Xtal Basic is worthwhile.

Without sacrificing any instructions or suffering any loss of speed, the Xtal Basic occupies 5K less RAM. There are more than 12 additional commands packed into the reduced interpreter including the following:

```

DEEK          DOKE
PRINT @       ON ERR GOTO/GOSUB
WAIT          SPEED
POP           POS
AND OR and NOT
IF THEN ELSE

```

The Xtal Basic works with six significant figures instead of eight, but has an extended exponential range. The PRINT @ command in the Xtal Basic allows graphs and tables to be plotted easily on screen and is accompanied by less snow than the more primitive Sharp POKE command. A disadvantage for some prospective buyers will be the lack of any printer routine in the Xtal Basic.

The documentation with the Xtal Basic tape consisted of a printed pamphlet describing the general features of the language and its application to the Nascom computer and a photocopied booklet setting out modifications specific to the Sharp version.

There are instructions for adding to the Basic instruction set in the original Nascom booklet and the conversion

A		B
A15	1	G
A14	2	INT
A13	3	G
A12	4	MREQ
A11	5	G
A10	6	IORQ
A9	7	G
A8	8	RD
A7	9	G
A6	10	WR
A5	11	G
A4	12	MI
A3	13	G
A2	14	HALT
A1	15	G
A0	16	RESET
G	17	G
D7	18	G
D6	19	G
D5	20	G
D4	21	G
D3	22	G
D2	23	G
D1	24	G
D0	25	G

▷ Mark
Bus Connector Detail

Figure 1. MZ-80K connection details for the 50-way system bus.

leaflet supplied with the tape has some information about port numbers, relevant memory locations and an example of a printer subroutine. A major advantage of the Xtal Basic is the additional program — Xtalbug — which allows machine-code modifications and insertions to be made to the Basic interpreter. The facility is powerful, well worth having, and a complete contrast to the jealous approach taken by Sharp, which prohibits the user from taking even a security copy of the master tape, both in writing and in the software.

Also on the second side of the Xtal tape is a conversion program for translating programs recorded in Sharp Basic to Xtal Basic. The program worked successfully although the one command not translated — GET — required some syntax changes in the converted program. There are suggestions for modification in the Xtal manual.

The major improvement in disc Basic is that it permits sequential and random-access storage of data on disc and contains two commands — CHAIN and SWAP — which allow whole programs to be called from a disc, with execution and existing variables transferred to the new program. The SWAP command returns the first program to the CPU at the completion of the second, and the first program continues its execution.

The error handling of the disc Basic is enhanced greatly in comparison to the tape version. There are one or two additional instructions but no PRINT USING command or IF THEN ELSE, both of which might have been expected in a disc version.

Conclusions

- The MZ-80K is mechanically and electrically well designed and constructed with the exception of the keyboard.
- Particularly at discount prices, the machine offers an impressive specification.
- Although the machine has no inherent input/output capability, the Sharp bus is well buffered and is readily available for proprietary or home-built expansion units.
- The machine needs a re-set switch for assembly language and machine-code programming as there is no way out of loops or Halt (76H) instructions other than by switching the machine off, when the RAM contents are lost.
- A volume control on the outside of the case would improve the usability of the computer.
- The MZ-80K, floppy disc, printer combination can be locked up in too many ways; for example, if by accident, there is stored in a disc directory two quotes without an intervening space, "", attempting to save any file by any name gives error 42, i.e., tried to register under an existing name.
- The price/performance ratio of the Sharp peripherals is not in the same class as the MZ-80K itself. The MZ-80 I/O interface unit is expensive for what it does and although the floppy disc unit is well made, it also looks expensive in comparison with other reputable units.



The MZ-8FD floppy disc unit.

- The printer matches the system both in its graphics set and styling but is definitely not in the van of equipment.
- There is often much to be said for using a well-tryed and reliable design rather than a bug-ridden designer's dream and in those terms, the MZ-80P3 is a successful, hard-working printer but as such, its price is high.
- The Xtal Basic tape is good value for money, releasing RAM and offering an enhanced instruction set.
- When Xtal incorporates a standard printer routine into its tape Basic, I hope it will include a command to print the contents of the VDU screen — a comparatively rare but valuable facility

lacking in both the Sharp versions of Basic.

- The Sharp Basic manuals are bad translations but offer many examples to illustrate individual instructions and programming techniques.
- The service manuals for the MZ-80K and printer are excellent — a stark contrast — containing fault location flowcharts, test programs and waveform illustrations for various test points as well as the usual circuit diagrams.
- The Sharp machine language manual is good apart from poor-quality translation.
- The Basic Sharp system back-up is not the worst of its kind but it is far from adequate and cannot match in any way the documentation supplied with, for example, the Apple II.
- The keyboard prohibits the use of the MZ-80K in any environment where typists will switch from a normal typewriter to the computer and back again.
- A word-processing package for the MZ-80K would appear a wasted effort as the machine does not seem suitable for business use of this kind.
- On the other hand, the bus is well buffered and the computer strongly constructed, and with the addition of D-A and A-D converters of the kind produced by 3D Digital Design and Development among others, the MZ-80K offers good hardware value for laboratory workers who wish to control experiments and for engineers, most of whom will be unable to touch type.

? DIRTY MAINS ?

Is the mains supply to your computer as clean as it could be?

The MF 10A MAINS FILTER UNIT

attenuates noise and high voltage transients.

The 10A capacity self contained unit with fuse, neon, and on/off switch offers a low cost solution to mains borne interference problems.

Price **£68** each (ex VAT)

Data sheet available from:

ALAN KIDDLE ASSOCIATES LIMITED
Fairlight House, 729 London Road
Hounslow, Middlesex TW3 1SE.
Phone 01-543 0179 Telex 965649

● Circle No. 159

Announcing
Next Day delivery of
computer supplies,
accessories and cables!

Anything in Inmac's new Catalogue can be in your Computer Room *tomorrow* (2 days to Northern Ireland). Even faster in an emergency! There's a wide range of over 500 top quality accessories, supplies and cables to choose from, many of which are hard to find elsewhere. A direct telephone line offers you an instant, trouble-free ordering service, with advice always available. Everything covered by the Inmac no-nonsense Guarantee of Satisfaction.

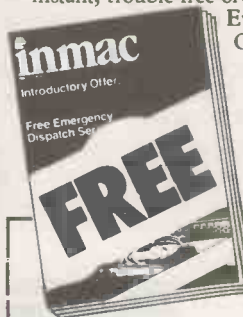

IF YOU DON'T BELIEVE US - TRY US!

For **FREE** Catalogue, telephone Runcorn

(092 85) 67551

Telex 629819 INMAC G or write to:

INMAC LTD., Dept C, PC5/81
18 Goddard Road, Astmoor Industrial Estate, Runcorn, Cheshire WA7 1QF.

Name _____

Company _____

Company Address _____

● Circle No. 160

AutoPay

**NOW
AVAILABLE**



£195₊ VAT
from your nearest
'Apple' dealer

- Easy to use
- Very fast
- Friendly
- Flexible
- Complete software support
- Comprehensive manual

AutoPay is a fast and versatile payroll program, which can be set to individual user's requirements, to the extent that it has found great favour with both small and multi-national companies.

Operation can be mastered speedily by a novice and its options of auto, supervised auto and manual modes allow for complete flexibility.

AutoPay is a professionally written business program, which is a superb asset to any progressive organisation. Naturally all Tax and National Insurance codes, hourly, basic and salaried employees, variable and standard post- and pre-tax additions can be handled.

Amongst its many outstanding features are seven pay periods; fixed, variable and percentage company pensions; cash, cheques and credit transfer analysis and many other useful factors.

If used as part of the integrated system an AutoPost function enables complete general accounting control. This original payroll system will process hundreds of employees in minutes of operator's time.

AutoPay is part of Micro Management's business software suite and is available from your local Apple dealer.



Micro Management Ltd.
32 Princes Street, Ipswich, Suffolk
Tel: Ipswich (0473) 57871

THE SOFTWARE
SPECIALISTS



Actual photographs



Flexible

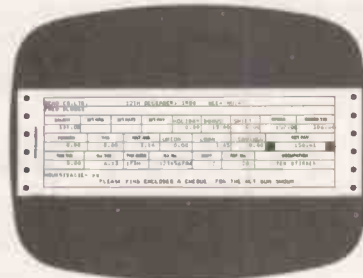

Pre printed or plain



Easy to read



Variable Payments

• Circle No. 161
PRACTICAL COMPUTING May 1981

VERSAWRITER II is a low-cost — about £150 — add-on peripheral for the Apple II. It consists of a perspex sheet attached to which is a pivoted arm and cursor point. The arm is connected via a ribbon cable to the games input/output socket inside the Apple. In addition to the hardware, there are two floppy discs containing the software routines for sensing and driving the drawing tablet. The product requires a 48K Apple with two floppy disc drives and ROM-based Apple-Soft. A 12-page manual is provided.

Versawriter reproduces the movement of the cursor on the perspex tablet on to the screen under the control of the Apple

by Mike McDonald

using high-resolution graphics mode. The cursor movement is translated by the x and y movements which are detected by two potentiometers mounted in the pivots of the cursor arm.

Apart from just drawing pictures on the screen, shapes may be defined and stored away in shape tables and may be recalled at will to be used to assemble a picture or diagram.

On loading the master program from disc a main menu offers the following functions:

1. Draw with Versawriter
2. Calibrate system
3. Recall a stored picture
4. Catalogue this disc
5. Add text to picture
6. Calculate area and distance
7. Electronic drawing
8. End session

Our first job was to calibrate the system. A calibration chart is provided and had to be mounted on the tablet — it has a transparent cover sheet under which documents may be placed — and the calibration program prompts for a series of alignment movements with the cursor arm.

The parameters of the alignment are stored on the master program disc for future reference. We were then able to select the "draw with Versawriter" option from the menu. This option caused a program to be loaded offering the following functions:

- P point cursor — draw line
- S scale of drawing
- T transfer picture to disc
- R recall picture from disc
- C centre on screen current point
- F smoothing factor
- E erase screen
- Z colour closed figure in current colour
- D draw with brush or edit
- M make a shape table
- I inspect shape table
- L list of commands
- Q quit program
- Colours: W white
- O orange
- G green
- 0 black
- B blue
- V violet

If you hit any key, the screen blanks and displays a tiny flashing pixel — picture element — to represent the position of the cursor. Any of the

Versawriter II: an inexpensive line in graphics drawing



commands given, may then be entered through the keyboard to affect the display. If left in its default mode, the cursor flashes and follows any movement entered via the cursor on the tablet assembly.

If a colour key — i.e., the letter representing the colour — is hit any movement is then reproduced as a solid line in the appropriate colour on the screen. A solid line will continue to be produced until the P key is hit to release that function. The scale of the movement may be magnified through the "S" option and a scaling factor between 1 and 5 may be entered. Movements are then multiplied by this on the screen.

The smoothing factor is a damping effect which reduces any jerkiness of

movement or sudden change in direction. Having drawn a few random patterns on the screen, one option is that closed shapes may be filled with colour automatically. This is achieved by placing the cursor point in the area to be filled and selecting option "Z". The user is then prompted for a colour number and offered a test fill or reversed-out background before proceeding. The facility seemed to work well except that very irregular shapes were not filled completely.

The draw with brush allows a brush size between 1 and 5 to be defined and results in a pulsating blob which can be moved around, depositing any selected colour as it goes. Once a picture has been produced, it may be saved on disc — this did not

(continued on next page)

(continued from previous page)

work very well in our case — and subsequently recalled. The screen is erased by entering "E" and confirmation that you want to blank all efforts.

Shape tables may be created and used and this is where Versawriter becomes a more viable proposition for commercial applications. A number of shape tables is provided on disc, including electrical shape, electronic shapes, geographic shapes, chemical symbols, chemical apparatus, landscape shapes, plumbing shapes, and so on.

A picture may be formed up on the screen of a series of specific shapes or items while in the drawing mode. Once complete, the items may be compiled one by one for storage into a shape table. The shape table may then be accessed and will allow the user to step through the stored shapes and dump each shape on to the screen wherever the cursor is positioned.

Hence, from the electronic shape table, we were able to produce reasonably sophisticated circuit diagrams at high speed with little or no drawing ability. The applications here are endless for any profession or discipline which utilises drawings or diagrams.

We loaded an electrical shape picture and put a series of shapes into a table. The screen is cleared and the table recalled with the I function. The bottom of the display shows the following options:

S scale = 1
D drawing number 1 or CTRL D
X fix S Y fix Y U undraw
R rotate

When you call a shape table on to a blank screen, the first shape stored is flashed on the screen continuously at the present cursor location. By pressing the space bar, it may be deposited in its position as a drawn object. Otherwise, some of the options may be used to alter its characteristics.

The scale may be increased although we found that irregular shapes lost quality once enlarged past double their table size. If R is pressed, the shape rotates through 45 degrees and will continue to do so if R is held down. D causes the system to move on to the next shape in the table in a sequential fashion or control d allows the user to go directly to a specific shape number.

Either an X axis or Y axis may be set and fixed with the X and Y function keys. That is very useful if creating regular shapes and diagrams and produces a neat picture. Once an axis is set, cursor movement will be possible only along it. N returns the user to normal movement.

There is also an undraw or U option whereby a mistakenly-placed shape may be removed by placing the same shape over it and pressing U. This masks the offending part of the diagram. You must put the blanking shape exactly on the old version to obliterate it completely.

Three shape tables on the master disc where English, Greek, and Electronic

shapes. The English and Greek were alphabets which could be used to label diagrams. Hence the system could be used for foreign-language character generation. Once the shapes have been accessed and used to form a picture, the user may return to the normal free-hand mode of drawing to make additions, amendments, or deletions. The resulting picture may then be stored on the disc.

In addition to using a text shape table to put letters on diagrams, there is also an "add text to picture" function which allows the user to type directly in through the keyboard labels of varying size and colour, again positioned with the cursor.

There was a very interesting routine on one of the discs which produced standard shapes for drawing i.e., triangles, squares, rectangles, rhomboids, trapezoids, and so on. Each shape was defined by selecting a letter and the cursor was then placed at the start position and end position. Versawriter would do the rest.

We were able to create some amazing multi-dimensional diagrams with very little effort and the feature is a dream come true for those who have ever had to produce an isometric drawing of a complex shape in engineering drawing classes.

Another facility of the package is a calculate area and distance function. This routine allows the operator to draw a picture or recall a picture on to the screen and then proceed to map the form through scaling calculations.

A scale is calibrated in terms of the two extremes of movement of the cursor on the screen and the user is prompted for a scale factor and the units of scale, for example, 10m. Any subsequent cursor movement is measured and a display given of distance — or perimeter in the case of a closed object — and an area calculation may be requested to produce a square measurement of an enclosed shape.

Demonstration programs are provided with the package and produce some amazing pictures someone surely spent years producing.

Conclusions

- Versawriter would appear to be an extremely useful facility for the educational market and possibly the commercial market if there were some way of producing an enlarged hard-copy print of the screen.
- With the several versions supplied to *Practical Computing*, we had difficulty storing a picture on disc and retrieving it again intact.
- The programs also suffered from a lack of consistency which, was somewhat irritating at first.
- The screen graphics are certainly of a good quality and some very complex diagrams and pictures can be produced with a little patience and a good deal of practise.
- Notes are provided for those interested in producing their own programs for use with the drawing tablet. □

NEW from Computer Centre

WINCHESTERS

Our Winchester fixed disc systems are now in production.

OEM 4

Stand alone S100 main frame with DMA controller to the hard disc.

**20 MEGABYTES
(DRI 3100 WINCHESTER)
Z80 . 80K BYTES . FLOPPY
SERIAL & PARALLEL I/O**

£4,950

SUB SYSTEM

This will interface to any single density floppy disc controller. Plug compatible to most existing 8 inch floppy systems.

**20 MEGABYTES
(DRI 3100 WINCHESTER)
INTELLIGENT INTERFACE**

FROM £2,500

NEXT...OEM 5

**MULTI USER SYSTEM
16 BIT MICRO
128K BYTES RAM
20 MEGABYTE FIXED
1 MEG FLOPPY
FRONT END PROCESSOR
FOR UP TO EIGHT TERMINALS**

ALL FOR UNDER

£6,500



Comcen are also Apple dealers - Ring us for a quote - We have the best prices nationwide.

ComCen

9 De La Beche Street, Swansea, SA1 3EX
Tel: (0792) 460023, Telex: 48638
45-46 Wychtree Street, Morriston, Swansea,
Tel: (0792) 796000

computer
centre

Everything you want and more from Computer Centre

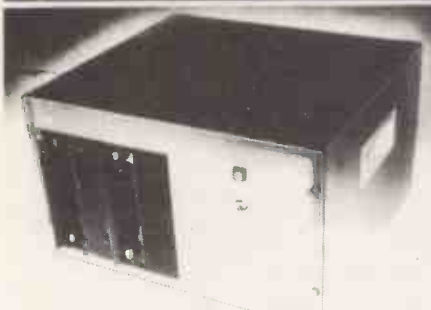

OEM FROM £1,970

High speed Z80 microprocessor. Twin 8" floppy disc drives. 16K to 256K bytes RAM. Up to 2 Megabytes on floppy discs. Supports Cobol, Fortran, Basic, Pascal, and PL/1. Multi-user versions. 20 Megabyte Winchester sub-systems.

The range of Comcen OEM machines starts with a six slot stand alone, Z80 with serial and parallel I/O at £499 and at the top of the range there are multi-user systems with 60 Megabyte Winchester fixed discs.

The common disc operating system for the OEM range of machines is CP/M which supports an extensive range of high level software. COMCEN also offer a free library of more than 40 8" diskettes packed with utility software, programming languages, user programs and games.



MEGABOX £890

MEGABOX DRIVES Two 8 inch single or double sided drives in an attractive case with built in power supply. Front panel has illuminated mains switch. Units are supplied with appropriate cables for direct mains connection and plug compatibility to mainframes. Versions are available for Apple (SVC controller required), Tandy Model 2, as well as add-on drives to COMCEN kits or OEM systems, and other Shugart compatible disc systems.



525 SPECIAL £195

BOXED 5 INCH DRIVE SA400 (or equivalent) Minifloppy drive with power supply and attractive enclosure. Compatible add-on to TRS80, COMCEN OEMO, Horizon, Nascom, and many other standard floppy controllers. Mains cable and plug supplied, 34 way cables and connectors available to order.

Educational + OEM Volume Discounts Available

FIRMWARE + MANUALS

Please write or call for details.

PRICE LIST

OEM ASSEMBLED MACHINES

1560.00	OEMO Z80, 1SER, 1PAR, 2" 120K Disks
1970.00	OEM1 Z80, 32K, 1SER, 1PAR, 2" 1/2 MEG Disks
2270.00	OEM2 Z80, 48KB, 1SER, 1PAR, 2" 1/2 MEG Disks
4950.00	OEM4 Z80, 1SER, 1PAR, 20 MEG Fixed, 1 Floppy

COMPUTER CENTRE KITS

800.00	K1 Computer Centre Mini System 5 inch Disk
911.00	K2 Computer Centre Maxi System 8 inch Disk
208.00	Z80 Starter Kit

TIME SHARING SYSTEMS

2350.00	MUO 2 User MP/M 2" 120K Floppy Drives
3290.00	MU1 2 User MP/M 2" 1 MEG Floppy Disc
6660.00	MT 2 VDU S + MP M + 20 MEG Fixed + Floppy
5150.00	SD--200 Computer 64K

DISC DRIVES

890.00	Megabox-S 1win 8" Single Sided Drives Boxed
995.00	Megabox-D 1win 8" Double Sided Drives Boxed
2950.00	20 MEG Winchester Sub-System
275.00	8 In Single Sided Disc Drive
395.00	8 In Double Sided Disc Drive
199.00	Boxed 5 inch Drive with Power Supply
135.00	SA 400 Minifloppy Disc Drive
1350.00	DRE 3100 20 MEG Winchester Drive

VDU'S

695.00	Wordstar VDU
575.00	Pentland (Full Spec)

PRINTER'S

1790.00	QUME Sprint Daisywheel Printer
188.00	QUME Tractor
890.00	ANADEX 9500
449.00	ANADEX 8000
325.00	EPSON TX80
51.00	TX80 Graphics Option
345.00	EPSON MX 80

SOFTWARE

219.00	MP/M + Manuals
70.00	CP/M Operating System + 6 Manuals + Basic E
94.00	CP/M 2.2 + Manuals
209.00	COSMOS Multi-User OP System
4.50	Library Copies on 8 Inch Media
4.00	Library Copies on 8 Inch Media (10 or more)
85.00	Microsoft Macro 80
148.00	Microsoft Basic
202.00	Microsoft Basic Compiler
255.00	Microsoft FORTRAN
376.00	Microlocus Compact COBOL
590.00	Microlocus VERS 4 COBOL
60.00	C Basic 2
148.00	Datastar
179.00	Wordstar 2.1
49.00	Mailmerge
63.00	Z80 SD Global PKG
113.00	SDOS
60.00	FORTAN LIB for FPB
216.00	Configurable Business Package
60.00	Z-SID
255.00	Selector 4 C-2
127.00	Supersort 1

KITS	MPU	Assd
125.00	CB2 Z80A IEEE S100	163.00
118.00	Godbout Z80	145.00
178.00	SBC100 Z80 + Serial + Parallel	197.00
194.00	SBC 200	224.00
163.00	Godbout 8085/8088 Tandem Board	219.00

KITS	DISC CONTROLLER	Assd
126.00	Tarbell Single Density	179.00
179.00	Tarbell Double Density	233.00
149.00	Versafloppy 1 - Single Density	181.00
214.00	Versafloppy 2 - Double Density	240.00
99.00	Tarbell Cassette Interface	

KIT	RAM	Assd
86.00	8K Bytes Ecororam 2 (4Mhz) Static Ram	94.00
	16K Ecororam XIV (4Mhz)	155.00
180.00	16K Static Bank Sel/Ext Addr	185.00
231.00	24K Static Bank Sel/Ext Addr	236.00
298.00	32K Static Bank Sel/Ext Addr	333.00
245.00	Expandoram 2 (Dynamic) 16K Population	251.00
285.00	Expandoram 2 (Dynamic) 32K Population	290.00
322.00	Expandoram 2 (Dynamic) 48K Population	367.00
362.00	Expandoram 2 (Dynamic) 64K Population	

KIT	INPUT/OUTPUT	Assd
105.00	2SIO (2 Serial Full Handshaking UARTs)	130.00
82.00	I/O 4 2 Serial Parallel	138.00
332.00	MPC-4 Serial I/O Controller	358.00

KITS	SPECIAL BOARDS	Assd
226.00	VDB-8024 (80 Chis - 24 Lines) Video	263.00
88.00	PB1 2716 2708 Eprom Programmer	127.00
125.00	SD Prom 100 Programmer	150.00
49.60	2708 Prom Board (Ex Proms)	65.00
24.20	Active Terminator Kit	33.00
36.20	Memory Manager	46.00
98.00	VB2 64' 32 Video + keyboard Input Port	129.00
266.00	VB3 80' (Up to 51 Lines) + Graphics	303.00
175.00	Spectrum Colour 8k + Parallel	184.00
29.60	S100 Extender + Logic Probe	
21.00	MT13 11 Slot Motherboard	
	Floating Point	268.00
	A/D 16 Channel 12 bit	450.00

POWER SUPPLIES

195.00	S100 Laboratory Cardcage and Powersupply
77.00	Power Supply for Mini-Maxi Kit (1 Drive)
81.00	Power Supply for Mini-Maxi Kit (2 Drives)
16.00	Transformer (Bus + Drives)

CONNECTORS

2.80	PIS 100 Edge Connectors
0.20	Card Guides
2.20	AC + DC Connectors for Dri Disc
1.80	DC Connectors for SA400
7.80	50 Pin Edge Connector for Dri Disc
9.80	50 Way Speed Block Connector
1.60	50 Way Ribbon Cable (Per Foot)
7.00	34 Pin Edge Connector for SA400
8.00	34 Way Speedblock Connector
1.00	34 Way Ribbon Cable (Per Foot)
5.00	26 Pin Edge Connector for SBC100
6.00	26 Way Speedblock Connector
0.80	24 Way Ribbon Cable (Per Foot)
11.60	D25 Special Ribbon Cable Edge Connector
1.60	16 Pin IC Sockets (Pack of 10)
1.60	14 Pin IC Sockets (Pack of 10)

IC'S

14.80	WD 1771 SD Disk Cont
5.00	2114
3.00	4116 (Or Equivalent) 250 NS
1.00	2102
15.00	Z80A
5.00	5257 4K 1 Static
8.20	8251
77.00	16K Expansion (1RS 80/Apple)
7.40	2708 Eprom
7.40	2716 Eprom 350 NS
6.00	2716 Eprom 450 NS

MEDIA

23.40	8 Single Sided Floppy Media (Box 10)
35.80	8 Double Sided Floppy Media (Box of 10)
26.20	5 Single Sided Floppy Media (Box of 10)

CONSUMABLES

14.00	11" 14.5 Continuous Lined Paper (2000 Box)
12.40	12" 9.5 Continuous Plain Paper (2000 Box)
8.60	11" 9.5 Continuous Plain 60g (2000 Box)
37.40	Multistrike Ribbon (Qume Type) 12/Box
53.00	Singlestrike Ribbon (Qume Type) 12/Box
40.20	Fabric Ribbon (Qume Type) 12/Box
18.80	1X80 Ribbon 12/Box
6.60	Daisywheel Qume Type

Terms are Cash with Order
Please add 2% for Post and Packing and 15% VAT
(N.B. £2 Post & Packing on boxes of Stationary and Transformers)

ComCen

9 De La Beche Street, Swansea, SA1 3EX
Tel: (0792) 460023, Telex: 48638
45-46 Wychtree Street, Morriston, Swansea,
Tel: (0792) 796000

computer
centre

• Circle No. 162

THINKING SYSTEMS

Drawing on examples which range from the laws of supply and demand to sociology, Boris Allan shows how mathematical techniques can bring feedback into computer programs.

MY SUBJECT matter is not easily specified. Consider what Thinking Systems could mean:

- Systems which think
- Thinking using a systems approach
- Thinking about systems
- Thinking systematically

There are many meanings to the word system and this quotation from Jorge Luis Borges highlights the abstractness of these many ideas of system.

A system is nothing more than the subordination of all aspects of the universe to any one such aspect. *Tlon, Uqbar, Orbis Tertius.*

The way in which I approach the topic means learning by doing; and I hope to stress the integrity of the approach by showing how graphs, mathematics, paths, and programs all say the same things. I shall look in detail at two examples, and

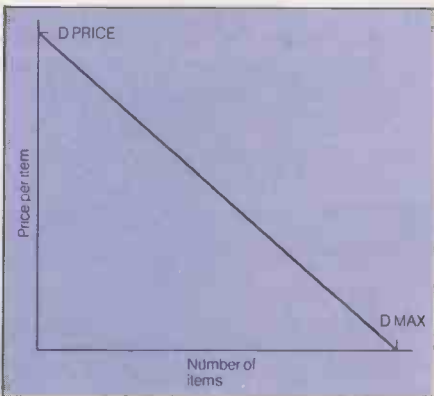

Figure 1. A demand curve.

show how we have to reduce the universe to the system we are studying. Following the examples, I give definitions and explanations of some system concepts.

We shall start with an example which appears in the teaching of economics at all levels, from CSE upwards. Consider the following hypothesis:

- The less a commodity costs, the greater the number of items of that commodity will be desired.

or, the lower the price of a retailer's microcomputers, the more people will buy from him. However, there is a limit to the number of, say, TRS-80s people can use, even if they are given away. We show this in economics by a demand curve with price on the y axis and the quantity of items demanded on the x axis. The curve is one which slopes down from top left — high price, no demand — to bottom right — low price, high demand. A specimen demand curve is shown in figure 1.

The next hypothesis to consider is:

- The greater the price at which a com-

modity can be sold, the greater the number of items which will be produced or, the greater the price that computer games for the Pet fetch, the greater the number of computer games for the Pet produced. That can also be shown on a graph: a supply curve with price on the y axis and the quantity of items supplied on the x axis. Figure 2 shows how the curve slopes upwards from bottom left — minimum price, no supply — to top right — high price, high supply.

A classical French economist Le Say formulated a law about supply and demand. Economists, being of an original turn of mind called it Say's Law:

- Supply creates its own demand or, if you swamp the market with useless software, there is a price at which some fool will buy some.

If we look at these two curves in conjunction, we begin to see the operation of a market. Say's Law suggests that if we supply a large number of items, the price charged for those items will be the one given for that number of items on the demand curve. The two curves are amalgamated in figure 3.

Suppose that $S(0)$ items are produced — because the producers think the items will each fetch a price of P — then "as supply creates its own demand" the number of items sold will be $D(0)$ where $D(0) = S(0)$, but the price for each item will be $P(0)$ and not P . As $P(0)$ is less than P then the suppliers have done less well than they predicted. This is the story told by figure 3.

Continuing a little: the producers will only produce $S(1)$ items at a price of $P(0)$, but the demand ($D(1) = S(1)$) for this

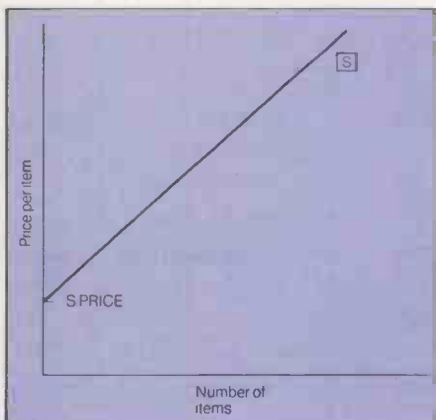

Figure 2. A supply curve.

number of items is such that the price each fetches is $P(1)$ — and $P(1)$ is greater than $P(0)$, so the suppliers have done better

than they expected. This continues until the point of intersection of the curves is reached — that point is the equilibrium price for those supply and demand curves.

At one time, the supply-and-demand mechanism was thought to assure a fair, i.e., equilibrium, price for all goods. That is, subject to random fluctuations, or the shapes of the curves changing over time. For our purposes the key, and erroneous, conclusion from graphs such as figure 3

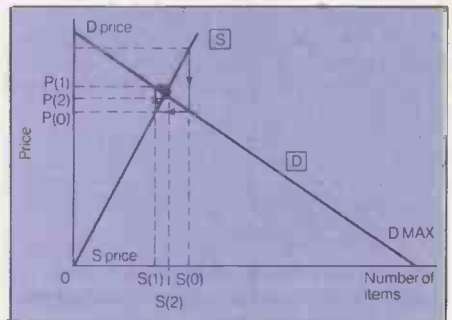

Figure 3. Supply and demand curves.

was that the path of price and supply changes always spiralled in to the equilibrium point.

An astute reader will see that this is not necessarily true, and the program, Say's Law, is designed to investigate just this phenomenon. First, however, some computer use is demanded.

To gain some practical experience of supply and demand before we learn more about its theory, we shall use the program, Say's Law. It is written in Applesoft Basic for the Apple II, and though such commands as HOME, i.e., clear screen and GET, i.e., input a character from keyboard, without echoing, are not common to all Basics, the logic is clear, and the REMarks copious. If the multi-statement lines are too long for, say, Pets, space out the statements — I have left 20 between line numbers.

The Say's Law program is a simulation of what the classical market is supposed to be — the equations, as programmed, try to copy what happens under the classical scheme or model.

When you run the program, in response to the first query set, your maximum demand to 100. You will then be told that the demand equation is

$$D(T) = 100 - 1 * P(T)$$

and you will have to wait for the next subsection to discover what that means. You will then tell the machine that the Supply Gradient is .2. The supply equation will be given as

$$S(T) = 10 + .2 * P(T-1)$$

Multiplier = -.2		
Time	Price	Supply
0	50.00	50.00
1	80.00	20.00
2	74.00	26.00
3	75.20	24.80
4	74.96	25.04
5	75.01	24.99
6	75.00	25.00
7	75.00	25.00

Table 1. Quick convergence to equilibrium.

with some mysterious quantity called the Multiplier being equal to $(.2)/(-1)$ or $-.2$. You will have set up two lines: the supply curve, and the demand curve with the equations given. These two lines will intersect at a certain equilibrium point and you will be informed that the Equilibrium Supply is 25. The next stage in your ride comes when you are asked how much is sold in year zero, to which you should answer 50.

A table under three headings is formed. The first heading is Time, period, the next Price, at which items are sold, and third heading is Supply — of items. This simulation starts at Time 0, Price 50, and Supply 20; and at Time 2, Price is 80, and Supply — based on the price of 50 in the last time period — is 20.

To continue output of results, hit any key, except F. F stops output of that series and the user can re-run using different values. When Time period 7 has been reached, the Price has stabilised at 75, and the Supply has stabilised at the equilibrium supply of 25 — see table 1. The classical economists would be satisfied with this result.

If the program is re-run with a maximum demand of 100, a supply gradient of .8 — giving a multiplier of

$-.8$ — and a supply in year zero that is not 50 — because 50 is the equilibrium supply — then, even after 30 time periods, the supply and price are still not quite stable. I show this in figure 4, which graphs Supply against Time. A supply gradient of .95 is even longer in reaching equilibrium — try it.

For fun, try a supply gradient of 1 — still keeping the maximum possible demand at 100 — with an initial supply of 80. Supply alternates between 80 and 30, with price alternating between 20 and 70 — our spiral has become a rectangle. Not so re-assuring for the classical economists as our earlier simulations.

When the supply gradient is 2, the equilibrium supply is 70 — for a maximum demand of 100 — the multiplier is $-.2$. If we start with a near-equilibrium supply of 72, then after five time periods, the supply should be 134 which exceeds the maximum possible demand — which is 100 — a highly unstable result which would not please the ancients.

Try various combinations of maximum demand, supply gradient, and initial supply, to see if you can discover what makes a system stable or unstable. In doing so, you will be studying a phenomenon which in economics is called the cobweb model, and is called negative feedback in other fields.

As we are dealing with quantities which vary over time, we emphasise the dependence on time by indexing our variables: $P(T)$ is the price at which items are sold at time T ; $S(T)$ is the number of items supplied at time T ; and $D(T)$ is the demand for items at a price of $P(T)$ — Say's Law postulates that $D(T)$ must equal $S(T)$.

The demand line shown in figure 1 has

the following equation which demonstrates

1. $D(T) = DMAX - DCOEFF * P(T)$ with $DMAX$ being the maximum possible demand, and the gradient $DCOEFF$ being given by

$$DCOEFF = DMAX / DPRICE$$

where $DPRICE$ is the price at which demand is zero. The supply line stretches upwards without any clear limit, unlike the demand line. The supply equation is

$$2. S(T) = SPRICE + SCOEFF * P(T-1)$$

with $SPRICE$ being the price at which supply is zero, and $SCOEFF$ is the gradient of the supply line — see figure 2. $P(T-1)$ is the price level of the previous

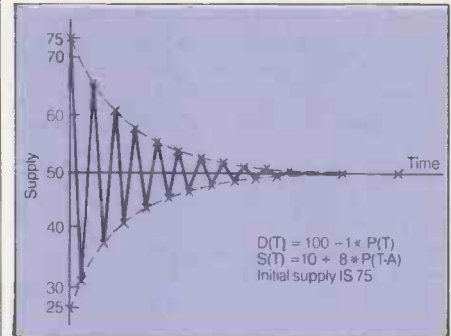

Figure 4. Reaching equilibrium.

period which influences the present level of supply.

If we add the further equation $D(T) = S(T)$, equation 2 becomes

$$3. D(T) = SPRICE + SCOEFF * P(T-1)$$

and when equation 1 is re-arranged we produce

$$.. P(T) = DMAX / DCOEFF - D(T) / DCOEFF$$

$$.. P(T-1) = DMAX / DCOEFF - D(T-1) / DCOEFF$$

(continued on next page)

```

100 REM
110 REM *****
120 REM
130 REM
140 REM SAY'S LAW
150 REM
160 REM A SIMULATION PROGRAM
170 REM
180 REM
190 REM BY
200 REM
210 REM G J BORIS ALLAN
220 REM
230 REM
240 REM *****
250 REM
260 REM THIS PROGRAM IS ONE OF
270 REM THE SET TO ACCOMPANY
280 REM
290 REM
300 REM THINKING
310 REM SYSTEMS
320 REM
330 REM ALL RIGHTS IN THIS
340 REM PROGRAM ARE RESERVED.
350 REM
360 REM (C) G J B ALLAN, 1980
370 REM
380 REM *****
390 REM
400 REM
410 REM
1000 DEF FN F(X) = (INT (100 * X + .5) / 100)
1020 DIM S(30),P(30): REM 'S' IS THE SET OF QUANTITIES SUP
PLIED, AND 'P' IS THE CORRESPONDING PRICE. BY ASSUMPTIO
N - SAY'S LAW - DEMAND ALWAYS EQUALS SUPPLY
1040 DPRICE = 100:SPRICE = 10: REM DPRICE IS PRICE AT WHIC
H DEMAND IS ZERO AND SPRICE IS PRICE AT WHICH SUPPLY IS
ZERO
1060 HOME: GOSUB 1840: PRINT "WHAT IS THE MAXIMUM POSSIBLE
": PRINT "DEMAND (BETWEEN 100 AND 10000) ": INPUT DMAX
: IF DMAX > 10000 THEN 1060
1080 IF DMAX < 100 THEN 1060
1100 GOSUB 1840:DCOEFF = DMAX / DPRICE: PRINT "DEMAND EQUAT
ION IS ": PRINT: PRINT TAB( 5); "D(T) = " ; DMAX: " - " ;
DCOEFF: " * P(T) "
1120 GOSUB 1840: PRINT "WHAT IS THE SUPPLY GRADIENT": PRINT
"(GREATER THAN ZERO) ": INPUT SCOEFF
1140 IF SCOEFF < 0 THEN 1120
1160 GOSUB 1840: PRINT "SUPPLY EQUATION IS ": PRINT: PRINT
TAB( 5); "S(T) = " ; SPRICE: " + " ; SCOEFF: " * P(T-1) ": GOSUB
1840
1180 GOSUB 1840: PRINT "MULTIPLIER = (" ; SCOEFF: " ) / ( - " ; DCOEF
F: " ) = " ; - SCOEFF / DCOEFF: GOSUB 1840
1200 GOSUB 1840: PRINT "EQUILIBRIUM SUPPLY IS " ; (DMAX - SPR
ICE) / (DCOEFF + SCOEFF) * SCOEFF + SPRICE: GOSUB 1840
1220 PRINT "HOW MUCH IS TO BE SOLD IN YEAR ZERO ?": PRINT "
(REMEMBER THE MAXIMUM POSSIBLE": PRINT "DEMAND IS " ; DMA
X: " ) ": INPUT S(0)
1240 IF S(0) <= DMAX THEN 1280
1260 GOSUB 1840: PRINT "SUPPLY IS GREATER THAN MAXIMUM": PRINT
"DEMAND, SO " ; S(0) - DMAX: " ITEMS ARE NOT UHED": GOTO 1
220
1280 P(0) = (DMAX - S(0)) / DCOEFF: REM PRICE AT TIME ZERO
ASSUMING ALL THE SUPPLY IS TAKEN
1300 IF P(0) < SPRICE THEN 1340
1320 GOSUB 1840: PRINT "THE PRICE (" ; P(0): " ) IS LESS THAN "
: PRINT "THE MINIMUM SUPPLY PRICE (" ; SPRICE: " )": PRINT
"SO THE MARKET COLLAPSES ": GOTO 1220
1340 GOSUB 1840: PRINT "TIME " ; "PRICE " ; "SUPPLY": PRINT
1360 PRINT 0, FN F(P(0)), FN F(S(0))
1380 FOR T = 1 TO 30
1400 S(T) = SPRICE + SCOEFF * P(T - 1): IF S(T) <= DMAX THEN
1480: REM CALCULATE THE NEW LEVEL OF SUPPLY
1420 GOSUB 1840: PRINT "SUPPLY EXCEEDS MAXIMUM DEMAND": PRINT
"BY " ; S(T) - DMAX: " ITEMS, THUS MARKET COLLAPSES": PRINT
"DO YOU WANT A RE-RUN (Y/N)?: GET A$: IF A$ = "Y" THEN
1040
1440 IF A$ = "N" THEN 1800
1460 GOTO 1420

```

(continued on next page)

(continued from previous page)

which, on substitution in equation 3, gives the result

$$4. D(T) = (SPRICE + DMAX/DCOEFF) - (SCOEFF/DCOEFF)*D(T-1)$$

This is fundamental: equation 4 shows how demand at time T can be exactly predicted at time T-1, and how a variable feeds back on itself to alter its own future value, though perhaps indirectly as in this case. We can also notice the key element in this fundamental result — the size of the multiplier, i.e., (SCOEFF/DCOEFF), would seem to be crucial.

Those who have tried the program will recognise the importance of the multiplier. I am using the names of the variables in the program in this mathematical section, as far as is possible, so that direct correspondences can be made.

If equation 4 is true, equation 5 must be true:

$$5. D(T-1) = (DPRICE + DMAX/DCOEFF) - (SCOEFF/DCOEFF)*D(T-2)$$

and a combination of equation four with five produces an interesting result

$$.. D(T) - D(T-1) = - (SCOEFF/DCOEFF) * (D(T-1) - D(T-2))$$

which explains many things. The left-hand side of this last equation equals the difference between successive values of the demand (D); and, if we define DDIFF(T)

to be $D(T) - D(T-1)$, then suddenly $6. DDIFF(T) = -(SCOEFF/DCOEFF) * DDIFF(T-1)$

or, successive differences in the values of demand are in a constant ratio $-(SCOEFF/DCOEFF)$. So: if the multiplier is between 0 and -1 in value, the series converges to a fixed value. If the multiplier is less than -1, the series diverges — and at -1 the series alternates between two values. The justification for these assertions lies in mathematical analysis work concerned with the sums of power series.

Equation 6 defines negative feedback:

- Negative feedback occurs when a change in value over one period produces a change in value in the reverse direction for a later period — for some series of values.
 - and from our investigations in practice, and in theory, we are able to define
 - Simple stable negative feedback generally occurs when the multiplier for successive differences is between — but not equal to — 0 and —1 for some series of values.
 - Simple unstable negative feedback generally occurs when the multiplier for successive differences is less than —1 for some series of values.
- The term negative feedback does not

mean adverse feedback, or stable feedback: negative feedback is defined by the sign of the multiplier, and the consequences are ours to evaluate.

Consider the three following cases:

- A. A pupil, D, is perceived by her teacher, O, to be of above normal intelligence. O expects, therefore, more from D, and this affects the way he acts towards D. The result of O's behaviour is that D is encouraged in her work, does better, and thus begins to appear relatively more intelligent. This apparent increase in ability by D reinforces O's belief in her intelligence, and so he encourages D even more — and so the story continues. This case is so common in schooling that it has been given the name, the self-fulfilling prophecy, by sociologists — that is, if you act as if someone is intelligent then frequently the person begins to act more intelligently.
- B. People in the industrial society, D's, have many, too many, illnesses. Administrators and politicians, Os, perceive the illness of the Ds, and the Os decide to increase expenditure on technological medicine. Unfortunately the result of the increased amount of technological medicine, e.g., more large hospitals with centralised facilities, at the expense

(continued on page 78)

(continued from previous page)

```

1480 P(T) = (DMAX - S(T)) / DCOEFF; IF P(T) > SPRICE THEN 16
      00: REM PRICE AT NEW LEVEL OF SUPPLY
1500 GOSUB 1840
1520 PRINT "NEW PRICE AT A SUPPLY LEVEL": PRINT "OF "; FN F
      (S(T)); " PRODUCES A DEMAND AT A": PRINT "PRICE OF "; FN
      F(P(T)); " WHICH IS LESS THAN": PRINT "THE MINIMUM PRICE
      FOR SUPPLY": PRINT "OF "; SPRICE; " - THE MARKET COLLAP
      ES"
1540 PRINT "DO YOU WANT A RE-RUN (Y/N)?"; GET A$: IF A$ =
      "Y" THEN 1040
1560 IF A$ = "N" THEN 1800
1580 GOTO 1520
1600 PRINT T, FN F(P(T)), FN F(S(T)): GET A$
1620 IF A$ < > "F" THEN 1700
1640 GOSUB 1840: PRINT "DO YOU WANT A RE-RUN (Y/N) ?"; GET
      A$: IF A$ = "Y" THEN 1040
1660 IF A$ = "N" THEN 1800
1680 GOTO 1640
1700 TCOUNT = T: REM 'TCOUNT' CAN BE USED IN GRAPHICS ROUTI
      NES, ETC.
1720 NEXT T
1740 GOSUB 1840: PRINT "DO YOU WANT A RE-RUN (Y/N) "; GET
      A$: IF A$ = "Y" THEN 1040
1760 IF A$ = "N" THEN 1800
1780 GOTO 1740
1800 GOSUB 1840: GOSUB 1840: PRINT "***** PROGRAM ENDS
      *****": GOSUB 1840: GOSUB 1840: REM A GRAPHICS ROU
      TINE CAN BE INSERTED AT THIS STAGE, USING 'S', 'F', AND
      'TCOUNT'
1820 END
1840 FOR I9 = 1 TO 3: PRINT : NEXT I9: RETURN
    
```

NOW YOU CAN PLAY SUPER INVASION ON YOUR ZX80!

**MOVING
GRAPHICS**

● TOTALLY FLICKER FREE

Absolutely no flicker. You don't need to press anything for the display to move!

● 3 LEVELS OF PLAY IN EACH GAME

From easy to dangerously difficult – you'll find it hard to resist the challenge time after time!

● MOVING GRAPHICS

No hardware modifications required for these exciting moving graphics games! Just follow the instructions for cassette loading and off you go – no need for new ROM or extra memory.

● MACHINE LANGUAGE

These programs are written in the computer's own language – only this way is it possible for continuous, flicker free action to occur.

● ALL PROGRAMS ON CASSETTE

Loads just like any other program on cassette. Each tape contains instructions on how best to load the cassette.

● FITS IK BASIC MACHINE

Amazing as it is, all these moving graphics programs fit into your basic IK Sinclair!

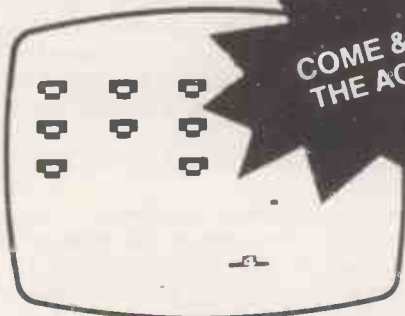

**COME & SEE
THE ACTION**

SUPER ZX80 INVASION

SUPER ZX80 INVASION is the moving graphics machine language game you and your Sinclair have been waiting for. Cruel and crafty invaders have been spotted in battle formation ready to attack with your ship just below them! Quickly and skilfully you shift right and left as you carefully fire your lasers at them. But watch out – they are accurate! 3 levels from easy to almost impossible to beat. Added bonus – each cassette also has more sophisticated 2K version which will automatically reset and challenge you for hours!

**3 LEVELS
OF PLAY**

DOUBLE BREAKOUT

You'll be amazed to see how difficult it is for you to break through the ZX80 DOUBLE BREAKOUT – and even more astonished to see this exciting moving graphics game fit into your IK Sinclair ZX80! Try your skill on the easiest level because even with the most skilfull bat control you'll find it hard to catch at the fastest level! Breaking through the first barricade is easy but don't be fooled for a second – it's much harder than you think! Two ball angles and curved bat will keep the excitement going for hours! Superb graphics!

£8

**PLUS ASTEROID LANDER,
PING PONG AND
MANY OTHERS**

AT LAST

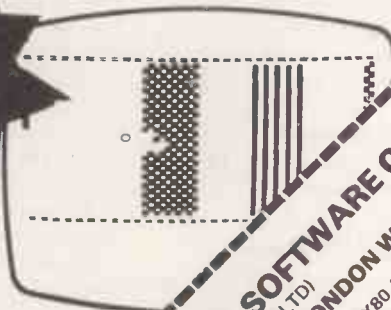

THE ESSENTIAL SOFTWARE CO.
(VISCONTI LTD)
47 BRUNSWICK CENTRE, LONDON WC1N 1AF

Please send me copies SUPER DOUBLE BREAKOUT.
I enclose cheque/postal order for

Name
Address

plus copies SUPER ZX80 INVADERS and
post and pack
PC5/81

• Circle No. 163

(continued from page 76)

of small neighbourhood, cottage hospitals, is to increase illness of the Ds. This increase in illness of the Ds leads the Os to increase expenditure on the high-technology medicine — which in fact produces illness. This is a condensed version of a series of arguments about medicine and health care in industrial society. These arguments are often phrased in terms of social iatrogenesis, medical nemesis, small is beautiful, etc.

C. A group of young people, Ds, are perceived by some police officers, Os, to be behaving suspiciously — the Ds are labelled as potential or actual delinquents by the Os. The Ds react towards this perceived antagonism of the Os by becoming more delinquent. The increase in delinquency by the Ds produces, of course, an increased level of harassment and surveillance by the Os. I do not think I need continue the story called in sociology deviance amplification, or the cycle of deviance.

What can we say about these three cases, other than that they are systemically almost identical? All three show that social behaviour can contain intrinsic conflict — whereas the economic model assumed an equilibrium state at the end, these cases all seem to point towards an unstable end.

In cases B and C, the result is contrary to that originally intended by the Os: in B illness is increased rather than decreased as a result of the action of the Os — though many dispute this. In C, delinquency is increased rather than decreased for this group of Ds — though in other cases, the action of the Os will have the desired effect.

In society in general, this conflict of expectations, and actions, is far more common than one would think despite the emphasis one finds in the relevant literature on negative feedback at the expense of positive feedback.

Nothing is that simple. We saw with negative feedback that we could have very unstable systems, and so we find with the cycle of deviance that stability can be reached — and it is the system multiplier that matters. Before you go any further just think back to Say's Law.

Deviance amplification

We have isolated two elements, the Ds and Os, and have seen how the value of some characteristic of the Ds, and the value of some characteristic of the Os, are mutually dependent; what are relevant elements and characteristics for the simple market? Details of how the program, deviance amplification, is structured can be seen from the REMarks, and the mathematical analysis I shall give.

The program uses the general term deviance for what in the examples A, B and C were different things — perhaps that is why one side was always called D?

In A, the deviance might be measured in IQ points above some norm. In B, the deviance might be measured in terms of some compound health index greater than some idea of what would be an acceptable value for the health index.

Finally, in C, the deviance might be measured in terms of some compound quantity made up of age, colour of skin, number of convictions, and type of neighbourhood. Most of our deductions from these models are qualitative, and the ideas are more important than the numbers.

In the program, we have "other(s)" who have a social reaction to deviance — called Os in the examples. For A, the reaction can be measured in some form by an index of teacher encouragement above the average. In B, the reaction can be measured in terms of extra, i.e., above the basic, money spent on medical technology. For C, the reaction could be gauged by the number of times the police arrest or pick up on suspicion.

When we run the program and are asked what is the effect of deviance on social reaction, we enter 1. The program responds by giving the information that the multiplier DR = 1. Next we enter the effect of social reaction on deviance, 1, and find that multiplier RD = 1. The system multiplier, SM, is given as RD*DR and is 1.

A little story is then told about the deviant(s). We assume that the deviant(s) are perceived to be different by 100 arbitrary units. The reaction by the other(s) to this deviance is 100*DR units of reaction — = 100*1 = 100.

This level of reaction increases the level of deviance by 100*RD units — that is, 100*DR*RD = 100*SM — the new level of deviance is thus 100 + 100 = 200 units of deviance. The program stops at this stage so that you can digest what has happened, and to continue any key is pressed.

The levels of deviance and of reaction, are then calculated for 30 time periods and an F stops the output at any point. For the values DR = 1 and RD = 1, both deviance and reaction steadily rise to 3100 — an explosive situation. Running the program with values of SM >= 1 will always lead to calamitous outcomes, but if we try DR = 0.5 and RD = 0.5, SM = 0.25, stability is reached reasonably quickly — deviance is stable at 166.67, and reaction is stable at 133.33.

The key is, again, the size of the multiplier, SM. Stability is reached if 0 < SM < 1 — so to suggest that positive feedback cannot, by itself, produce a stable system is incorrect. All depends on the multiplier.

Before I discuss the mathematics, one final point you may care to consider; in the program there is a function 'FNT' defined in line 1040, set it equal to

```
1040 DEF FNT(T) = EXP(-T)
```

and re-run some of your earlier values of DR and RD. FNT is the 'boredom' function, it tries to give some way of allowing the other(s) to get bored with the deviant(s). There are many other

functions you could try, e.g., FNT(T) = K/(K-1+T) where you chose the value of constant K.

As in the analysis of Say's Law, we index by time, and, as in the case of Say's Law, we will use the same names for the variables in the Basic program as we use in this mathematical analysis.

D(T) is the absolute level of deviance at time T, R(T) is the absolute level of reaction at T. The change in deviance from T-1 to T, i.e., D(T) - D(T-1), is shown as DD(T), and the corresponding change in reaction is shown as RD(T).

We start with an initial level of deviance D(0) = 100, and DD(0) = 100 — as we assume that D(-1) = 0: the change in deviance, not the absolute level, produces a change in reaction given by the formula:

$$1. RD(T) = DD(T-1)*DR$$

which in English, says that the change in reaction is proportional to the earlier change in deviance. The change in deviance at time T comes from:

$$2. DD(T) = RD(T-1)*RD$$

which says an equivalent thing about deviance being proportional to reaction change at an earlier time. Note that RD by itself is just a multiplier. An amalgamation of equations 1 and 2 produces

$$3. DD(T) = DD(T-2)*SM$$

so that we can see how the change in deviance feeds back on itself at a later time, SM = DR*RD. By a little thought we can see that

$$.. RD(T) = RD(T-2)*SM$$

which shows the importance of the multiplier SM. It is very easy to show that if SM < 1, assuming SM is positive, then the series will always converge to some fixed value. Compare equation 3 to the earlier equation 6 and consider the differences and similarities.

In a sense, equation 3 defines positive feedback

- Positive feedback occurs when a change in value over one period produces a change in value in the same direction for a later period — for some series of values.
- Simple stable positive feedback generally occurs when the multiplier for successive differences is between — but not equal to — 0 and 1 for some series of values.
- Simple unstable positive feedback generally occurs when the multiplier for successive differences is 1 or greater for some series of values.

If equation 1 is compared to the corresponding equation in line 1320, we find that the program the equation is given as the equivalent of

$$.. RD(T) = DD(T-1)*DR*FNT(T)$$

The extra function 'FNT(T)' is a function of time — set normally to unity, line 1040 — so that as the value of T increases, we can make the value of the multiplier relatively smaller. In this way, we can see that with boredom setting in, e.g., women's lib excites people less and less, most systems with positive feedback end up in stability, given time.

To finish off the mathematical analysis, I will suggest two books which have been found to have good sections on the mathematics used so far, i.e., linear graphs, and power/geometric series. The first book is directed towards A-level mathematics students; Sherlock *et al.*, 1979: 1-35, especially 24-27; 126-155, especially 139-146. The second is for applied mathematics courses at degree level; Green, 1964: 1-32. Both books are well written: Sherlock *et al.*, 1979, is excellent in this respect and though Green, 1964, is more demanding, an A-level student should have little difficulty with this text. For any reader who would like to be slowly introduced to mathematical thinking, Northrop, 1948, is unsurpassed.

I have not defined a system yet, though we have looked at four systems, and my definition of feedback has been very mathematical. Feedback has become a vogue word: it is in all the best, and worse, books. In one, we read a confusion of negative feedback with feedback, and positive feedback being confused with no feedback:

As a result, even if Germany had won the war — which it should have done on paper — it is hard to see how it could have survived the peace. If an organisation denies feedback, it becomes unrealistic and unstable, apt to break up into rival dogmatic factions. If it allows feedback, it eventually has to placate so many rival interests that it becomes motionless and no threat. Laurie, 1980: 270-271.

I finish with one other example on

which you can exercise your critical faculties:

Negative feedback is inherently stabilising because it decreases the error while positive feedback is inherently destabilising and the error gains explosively in magnitude. *Entry on feedback, Stafford Beer in Bullock and Stallybrass, 1977: 230.*

I still have not defined system.

References

- Bullock A and Stallybrass O, 1977, *The Fontana Dictionary of Modern Thought*, Fontana/Collins: London.
 Green J A, 1964, *Sequences and Series*, RKP: London.
 Laurie P, 1980, *The Micro Revolution: A change for the better or for the worse?* Futura Publications: London.
 Northrop E P, 1948, *Riddles in Mathematics*, Penguin Books, Harmondsworth.

```

100 REM
110 REM *****
120 REM
130 REM
140 REM THE CYCLE
150 REM
160 REM OF
170 REM
180 REM DEVIANCE (1)
190 REM
200 REM
210 REM A SIMULATION PROGRAM
220 REM
230 REM
240 REM BY
250 REM
260 REM G J BORIS ALLAN
270 REM
280 REM
290 REM *****
300 REM
310 REM THIS PROGRAM IS ONE OF
320 REM THE SET TO ACCOMPANY
330 REM THE SERIES
340 REM
350 REM THINKING
360 REM SYSTEMS
370 REM
380 REM ALL RIGHTS IN THIS
390 REM PROGRAM ARE RESERVED.
400 REM
410 REM (C) G J B ALLAN, 1980
420 REM
430 REM *****
440 REM
450 REM
1020 DEF FN F(X) = (INT (100 *
X + .5) / 100): REM FORMATT
ER
1040 DEF FN T(T) = 1: REM THIS
LINE CAN BE CHANGED TO ACCO
UNT FOR DIFFERENT EFFECTS OF
TIME, EG FN T(T)=EXP(1-T)
1060 DIM D(30),R(30),DD(30),RD(3
0): REM 'D' IS ABSOLUTE LEV
EL OF DEVIANCE, 'R' IS THE A
BSOLUTE LEVEL OF SOCIAL REA
CTION, 'DD' IS THE CHANGES I
N LEVEL OF DEVIANCE, AND 'RD
' IS CHANGE IN LEVEL OF REAC
TION
1080 HOME : GOSUB 1580: PRINT "W
HAT IS THE EFFECT OF": PRINT
"DEVIANCE ON SOCIAL REACTION
?": PRINT "(THE DEVIANCE TO
REACTION": PRINT "MULTIPLIE
R.) ": INPUT DR: PRINT : PRINT
"MULTIPLIER DR = ":DR
1100 GOSUB 1580: PRINT "WHAT IS
THE EFFECT OF": PRINT "SOCIA
L REACTION ON DEVIANCE?": PRINT
"(THE REACTION TO DEVIANCE":
PRINT "MULTIPLIER.) ": INPUT
RD: PRINT : PRINT "MULTIPLIE
R RD = ":RD
1120 GOSUB 1580: PRINT "THE SYST
EM MULTIPLIER (SM) IS ":SM =
RD * DR: PRINT FN F(SM): PRINT
"(SM = RD * DR)"
1140 GOSUB 1580: PRINT "PRESS AN
Y KEY TO CONTINUE": GET A$:
GOSUB 1580: PRINT "IF 0 (ZE
RO) IS 'NORMAL', AT": PRINT
"TIME ZERO THE OTHER(S) PERC
ENTAGES": PRINT "THE DEVIANT(S
) TO BE 'DIFFERENT' BY": PRINT
"100 UNITS."
1160 PRINT : PRINT "THE REACTION
BY OTHER(S) TO A": PRINT "D
EVIANCE OF 100 UNITS, IS AN"
: PRINT "PERCEIVED REACTION
OF 100*DR UNITS.": PRINT "TH
AT IS, THE REACTION IS ": FN
F(100 * DR):" UNITS."
1180 PRINT : PRINT "THIS IN TURN
INCREASES THE": PRINT "LEVE
L OF DEVIANCE BY ": FN F(100
* DR):"RD": PRINT "=" : FN
F(100 * SM):" UNITS: THIS PR
ODUCES ": PRINT "A NEW LEVEL
OF DEVIANCE OF ": FN F(100 *
(1 + SM)): " UNITS"
1200 PRINT : PRINT "PRESS ANY KE
Y TO CONTINUE": GET A$
1220 HOME : GOSUB 1580: PRINT "T
IME", "DEVNCE", "REACTN"
1240 DD(0) = 100:D(0) = DD(0):RD(
0) = DD(0) * DR:R(0) = RD(0)
: REM INITIALIZATIONS
1260 PRINT : PRINT 0,D(0),R(0)
1280 FOR I = 1 TO 30
1320 DD(I) = RD(I - 1) * RD:D(I) =
D(I - 1) + DD(I):RD(I) = DD(
I - 1) * DR * FN T(I):R(I) =
R(I - 1) + RD(I)
1340 PRINT I, FN F(D(I)), FN F(R
(I))
1360 GET A$: IF A$ ( ) "F" THEN
1440
1380 PRINT : PRINT "DO WANT A RE
-RUN (Y/N)?:": GET A$: IF A$
= "Y" THEN 1080
1400 IF A$ = "N" THEN 1540
1420 GOTO 1380
1440 'COUNT = I: REM 'COUNT' CA
N BE USED IN GRAPHICS ROUTIN
ES, ETC.
1460 NEXT I
1480 GOSUB 1580: PRINT "DO YOU W
ANT A RE-RUN (Y/N)?:": GET A
$: IF A$ = "Y" THEN 1080
1500 IF A$ = "N" THEN 1540
1520 GOTO 1480
1540 GOSUB 1580: GOSUB 1580: PRINT
"***** PROGRAM ENDS *****"
: GOSUB 1580: GOSUB 1580: REM
IT IS POSSIBLE TO INSERT GRA
PHICS ROUTINES AT THIS STAGE
, USING 'D', 'DD', 'R', 'RD',
AND 'COUNT'.
1560 END
1580 FOR I9 = 1 TO 3: PRINT : NEXT
I9: RETURN
    
```

Transdata's Cx500 Microcomputer Family

Multi-user hard disc

Single-user floppy disc



The Transdata Cx 500 family of Business and Scientific Microcomputers features upgrade potential from the Cx 502 single user 8" floppy disc system to the Cx 504 multi-user hard disc system. All Cx 500 systems feature an advanced multi-processor architecture which results in higher performance with simple expansion.

Experienced End Users, Computer Professionals and Distributors will value the quality, reliability and after sales support offered with these advanced U.K. manufactured microcomputers.

Cx 500 Features & Expansion

Z80A Master Processor 4 MHz
64Kb RAM, ROM BOOTSTRAP
Four V24 Serial Interfaces
8" IBM compatible floppy disc
20 Megabytes Winchester Hard Disc
Cartridge Tape Back-up
Extended memory with bank switching

Cx 500 The Complete Family

Cx 502 - Dual 8" Floppy Disc System
Cx 503 - Winchester Hard Disc System with 8" Floppy
Cx 504 - Hard Disc System with Cartridge Tape Backup & 8" Floppy

Operating Systems

SINGLE USER choose either CP/M or MicroCobol BOS
MULTI-USER choose MP/M or MBOS

Proven Software

Wide choice of languages for CP/M and MP/M including BASIC, FORTRAN, COBOL and APL.

Quality Commercial Accounting packages for BOS and MBOS.

COMSPAK: Transdata's Communications Software Package for connecting Cx 500 Systems to most remote computers (The modem interface is a standard feature of all configurations).

NETWORKING: Connect Cx 500's and share resources.

System Upgrade

The Cx 500 family offers upgrade potential with compatible software.

Customer Support

Cx 500 Systems are fully supported in the field by Transdata's own Field Service Division - not a third party organisation.

Peripherals

Choose from our range of VDU's, Printers and Paper-tape equipment to complete your Cx 500 configuration.

*OEM Discounts Available.
Dealer and Distributor enquiries welcome.*

Cx 500 Microcomputers - The Problem Solvers

TRANSDATA LIMITED

DATA TERMINALS AND COMMUNICATION SYSTEMS
Sales and Marketing Division Telephone: 01 403 5115
Battlebridge House, 87-95 Tooley Street, LONDON, SE1 2RA.

Please send me
more information
about your
Cx 500 Family of
Microcomputers

Name _____
Company _____
Address _____
Tel _____

Program angled to deal with class-room trigonometry

FOR MANY YEARS the computer has been used in a variety of ways in education, but even with the arrival of the microprocessor, the cost is still prohibitive for most schools. To make any significant contribution to the learning process, several terminals would be required and this immediately raises the price beyond the reach of a school budget. Many schools, however, now possess one terminal, run from a micro and soon many more will be similarly equipped. It is the aim of the Basic program which follows, to offer the teacher an opportunity to make more efficient use of such as terminal, not as a learning machine, but rather as a teacher's auxiliary.

It performs this function in two ways: firstly, by supplying an unlimited number of random examples — and answers if required — for the teacher's use; and secondly by making available individual examples for each pupil, who, on entering a personal code number, is offered a choice of problem. The answer is filed under the same code number, by means of which the pupil can check his own result later.

In this way a whole class can be accommodated, some individually at their own speed, others from specific examples on the black-board — but all quantities supplied when required by the computer. Most teachers would agree that in the subject of maths, few books supply a sufficient number or variety of questions; so the program fills a gap here, too. It will continue to churn out different sets of values as long as required, limited only by the random function of the Basic interpreter in use.

This month we offer a program in trigonometry, suitable for third-and fourth-year pupils and which supplies examples requiring a knowledge of the sine and cosine rule. Similar programs have been arranged to deal with other maths topics and a school with a library of these would be able to claim that the micro had more than justified its cost — especially as there is a bonus. The use of a personal number code appears to promote a greater interest in finding the correct answer and even the dispirited are inspired.

Robert Ferguson.

```

0010 PRINT "    CLASS TRIGONOMETRY"
0020 PRINT
0030 PRINT
0050 PRINT "CODE NUMBERS ARE RESTRICTED"
0060 PRINT "TO VALUES FROM 100 TO 140"
0062 PRINT
0063 PRINT
0070 P$(1)="SINE RULE?"
0075 P$(2)="COSINE RULE?"
0080 P$(3)="UNITS"
0085 P$(4)=" (FOR THE COSINE)"
0090 P1=3.14159265
0092 P2=180/P1
0095 T$="ABCDEFGHIJQRSTUVWXYZ"
0110 DIM P(41),R(41),U(41)
0120 PRINT "    IDENTIFY YOURSELF"
0130 PRINT
0140 PRINT "    TYPE IN YOUR CODE"
0145 PRINT
0150 GOSUB 400
0160 PRINT "    WELCOME, ";N$
0170 PRINT "    IF YOU PREFER EITHER"
0180 PRINT "    THE SINE OR COSINE RULE"
0190 PRINT "    TYPE SIN OR COS"
0200 PRINT "IF NO PREFERENCE, TYPE NO"
0210 INPUT P$
0220 X=0
0230 IF P$="SIN" THEN X=1
0240 IF P$="COS" THEN X=2
0250 IF P$="NO" THEN X=3
0260 IF X=0 THEN 385
0265 P(N)=X
0270 ON X GOTO 500,850,1300
0275 PRINT " ... AND RETURN WHEN YOU HAVE"
0280 PRINT TAB(10);"THE ANSWER"
0285 PRINT
0290 PRINT
0295 PRINT TAB(11);"NEXT PLEASE"
0300 PRINT
0305 PRINT TAB(8);"WHAT IS YOUR CODE?"
0310 GOSUB 400
0312 PRINT
0315 IF P(N)=0 THEN 160
0320 IF P(N)<0 THEN 1350
0325 PRINT
0335 PRINT "THE RESULT OF YOUR EXAMPLE IS"
0345 PRINT TAB(5);R(N);" ";P$(U(N))
0352 PRINT
0355 PRINT TAB(8);"ANOTHER EXAMPLE?"
0360 PRINT TAB(7);"TYPE YES OR NO"
0365 INPUT Q$

```

(continued on next page)

(continued from previous page)

```

0368 PRINT
0370 IF Q$="YES" THEN 1100
0375 IF Q$="NO" THEN 1400
0380 PRINT "TYPE YES OR NO ... RE-ENTER"
0381 INPUT Q$
0382 GOTO 370
0385 PRINT "TYPE SIN COS OR NO"
0388 PRINT "RE-ENTER PLEASE"
0390 GOTO 210
0400 INPUT N$
0410 IF ASC(N$)<>49 THEN 450
0415 V=VAL(N$)
0420 IF V<100 THEN 450
0425 IF V>140 THEN 450
0430 IF V<>INT(V) THEN 450
0435 IF LEN(N$)>3 THEN 450
0438 N=V-99
0440 RETURN
0450 PRINT "I DO NOT RECOGNISE YOU"
0460 PRINT "CHECK YOUR CODE AND RE-ENTER"
0470 GOTO 400
0500 GOSUB 1000
0510 X1=INT(RND*200+300)/10
0520 Y2=INT(RND*1400+100)/10
0530 Z2=INT(RND*300+100)/10
0535 PRINT
0540 PRINT "IN TRIANGLE ";S$;" ,"
0550 PRINT S$(2)+S$(3);" = ";X1
0560 PRINT "ANGLE ";S$(2);" = ";Y2;" DEGREES"
0570 PRINT "ANGLE ";S$(3);" = ";Z2;" DEGREES"
0580 PRINT
0590 U(N)=3
0600 X2=180-Y2-Z2
0610 X3=X2/P2
0620 Y3=Y2/P2
0630 R2=X1*SIN(Y3)/SIN(X3)
0635 R(N)=INT(R2*100+0.5)/100
0640 PRINT "FIND THE LENGTH OF ";S$(1)+S$(3)
0645 PRINT
0650 GOTO 275
0670 IF F$="NO" THEN 285
0850 GOSUB 1000
0860 A=RND(0)
0870 IF A<0.4 THEN 1200
0900 X1=INT(RND*200+300)/10
0910 Y1=INT(RND*250+300)/10
0920 Z1=INT(RND*200+300)/10
0925 PRINT
0930 PRINT "IN TRIANGLE ";S$;" ,"
0935 PRINT S$(1)+S$(2);" = ";Z1
0940 PRINT S$(2)+S$(3);" = ";X1
0950 PRINT S$(3)+S$(1);" = ";Y1
0960 PRINT
0970 U(N)=4
0980 PRINT "FIND THE VALUE OF ..."
0990 PRINT " THE COSINE OF ANGLE ";S$
0992 R1=(X1*X1+Z1+Z1-Y1*Y1)/2/X1/Z1
0993 R(N)=INT(R1*1000+0.5)/1000
0994 PRINT
0995 GOTO 275
1000 S=INT(RND*10+1)
1010 S$=MID$(T$,S,3)
1020 FOR I=1 TO 3
1030 S$(I)=MID$(S$,I,1)
1040 NEXT I
1050 RETURN
1100 IF P(N)=3 THEN 170
1105 PRINT TAB(5);"STILL THE ";P$(P(N))
1110 PRINT TAB(5);"TYPE YES OR NO"
1115 INPUT R$
1120 IF R$="YES" THEN 1180
1130 IF R$="NO" THEN 1160
1140 PRINT "TYPE YES OR NO ... RE-ENTER"
1150 GOTO 1115
1160 PRINT TAB(6);"WHICH THIS TIME?"
1170 GOTO 190
1180 X=P(N)
1185 PRINT
1190 GOTO 270
1200 U(N)=3
1210 X1=INT(RND*200+300)/10
1220 Y1=INT(RND*200+300)/10
1230 Z2=INT(RND*1600+100)/10
1236 PRINT
1240 PRINT "IN TRIANGLE ";S$;" ,"
1250 PRINT S$(1)+S$(3);" = ";Y1
1255 PRINT S$(2)+S$(3);" = ";X1
1260 PRINT "ANGLE ";S$(3);" = ";Z2;" DEGREES"
1270 Z3=Z2/P2
1275 PRINT
1280 PRINT "FIND THE LENGTH OF ";S$(1)+S$(2)
1285 PRINT
1290 R=SQR(X1*X1+Y1*Y1-2*X1*Y1*COS(Z3))
1292 R(N)=INT(R*100+0.5)/100
1295 GOTO 275
1300 B=RND(0)
1310 X=1
1320 IF B<0.5 THEN X=X+1
1330 GOTO 270
1350 PRINT "WELCOME BACK, ";N$
1360 PRINT "I THOUGHT YOU HAD FINISHED"
1370 PRINT
1380 GOTO 170
1400 P(N)=-1
1410 PRINT
1420 PRINT TAB(6);"HAS EVERYONE FINISHED?"
1430 PRINT TAB(8);"TYPE YES OR NO"
1435 INPUT F$
1440 IF F$="YES" THEN 1480
1450 IF F$="NO" THEN 285
1460 PRINT "TYPE YES OR NO ... RE-ENTER"
1470 GOTO 1435
1480 STOP
1490 REM R.E.L.FERGUSON
1500 REM ABERDEEN 1979
READY
#run

```

WHAT BUSINESS manages to combine travel to exotic places on stockfinding missions, the daily handling of beautiful products — each with a detailed and characteristic history — a retail outlet in London's King's Road at the forefront of the fashion scene, and a mail order and wholesale business which exports thousands of products every month?

The answer, for those who have not already guessed, is beads. Peter and Karina Sterry opened their shop Hobby

by Cathy Lane

Hobby 10 years ago, at the very start of the 1970s' crafts boom. As the business developed, though, they gradually dropped their other craft lines to concentrate on their best-seller.

Today Hobby Horse stocks 1,000 kinds of beads, and most of them are sold in 10 or 12 colours. For the last four years, Sterry has been riding a boom, expanding sales at a zooming 80 percent a year or thereabouts — for 1980 Hobby Horse is expecting a turnover above £500,000.

Beads are big business. Says Peter Sterry: "Fortunately for me beads are made in places like Africa, the Far East, India, South America. I have to go on buying trips quite frequently, and I'm always on the lookout for new lines". Regular customers for the beads include the toy manufacturers and the rag trade.

"In the last few years the jewellery boom has helped us considerably", says Peter, homing in on one of the key factors for his recent success. "Many of our retail customers make up ear-rings and necklaces and sell them on market stalls; I see our beads everywhere. Bo Derek's hairstyle in the movie *Ten* did us a great deal of good, too, and the U.S. Indian fashions last autumn worked for us as well — beaded moccasins in particular have resulted in huge orders from shoe manufacturers".

The shop in Chelsea and the warehouse just around the corner are both Aladdin's

The staff of Hobby Horse's Chelsea shop.



Peter Sterry and the Hobby Horse Pet.



Pearls of wisdom from London bead business

caves of glitter and colour. Sterry seems to like the aesthetics of his business: certainly he has a deep-seated dislike of bureaucracy and paperwork: "I have one lever arch file which will hold all my correspondence for a year, and that's about it".

At present, the total office staffing consists of one part-time bookkeeper — the 10 other employees are divided between the retail shop, the wholesale side, and packing for the mail order business.

For just 12 people to produce £500,000 is a reasonable ratio of sales to staffing, one that many stocking and selling operations would envy. So, what is the secret?

"We've only been able to do it because

of the computer, though", says Sterry. "For instance, if I hadn't bought the Pet earlier this year, I would have had to take on four or five extra invoice typists by now".

Yet he is not just saving on new staff — that is a visible and quantifiable aspect of the case — but Hobby Horse is winning some equally important benefits in other directions, notably in increasing the speed and reducing mistakes in the invoicing and a tighter control of inventory.

The increase in the variety of beads sold and the problems presented by invoice typing were the key factors in buying a computer. Sterry admits cheerfully that he knew "absolutely nothing" about computers when he started looking around for one early in 1980: "I viewed them very much as fun toys". Still, he had ambition: "My objective was to buy a machine and program it myself to do the stock control and invoicing. It didn't look too difficult. I was quite confident. Besides, it looked interesting".

After talking to a few programmer friends, Sterry concluded that the Pet was the best buy at the low end of the market. It was widely available, tried and tested and generally well established, highly-rated by everyone, reportedly easy to use, and well supplied with ready-made extras in the form of games, business programs, and add-on goodies if the requirement for them were ever to arise in Hobby Horse's future.

So for £800, Peter Sterry bought a 32K Pet with a cassette unit but "the shop was totally unhelpful, and as a result they got no other custom from me".

(continued on next page)

(continued from previous page)

The new Pet sat in Sterry's study for some time, while he discovered very quickly that he was not interested in programming it himself. At the time, however, he went as far as computerising his price list. "It wasn't too hard. All the beads already had three-figure product references, so I wrote a simple program which used these catalogue numbers".

It may not have been hard, but it still took him four months. On the other hand, it was a genuine and sensible use of the computer. The price list was intended only for reference use by staff in the shop and the business, not for customers, and it was exactly the same as looking up the prices in a book as before. Hobby Horse had previously handled price changes by cutting and pasting new information over the old material in the catalogue. Automating the price book produced a clearer and error-free reference.

Sterry may have been deciding that he was no programmer, "but in fact, most of the delay in making the system work was due to the Commodore users' handbook for the Pet. I found it particularly bad"

Invoicing system

Meanwhile, the invoicing system was becoming a pressing problem on which the computer could usefully be employed. Sterry realised that this would necessitate buying floppy disc drives — it is almost impossible to implement a fast-access business computing system using the tape cassettes that he still had on his Pet.

He was however anxious to find a local supplier. His bad experience of buying a computer and the obvious advantages of dealing with someone located conveniently close prejudiced him strongly in favour of a neighbourhood trader. Fortunately, Logic Box had just opened shop in the vicinity. Sterry was quick to buy a printer, floppy disc drives and the ready-made Trader package written by the Bristol Software Factory.

Trader is a set of programs designed specifically for stock-holding retailers and wholesalers. Peter Sterry liked it, though not uncritically: "It is actually very good, but for me, there is one rather irritating thing about it — it doesn't sort data at all. This means that only the original input is grouped into product classifications. All new stock can't be entered into, say, the glass or bone bead group, but it does print our invoices very well".

Sterry reckons that if necessary he could do without the computer, and certainly he has not replaced the manual system. He does not depend on it 100 percent. Yet it is clear that the Pet has made a considerable difference to the running of his business.

That is the inventory question. Because the stock is so large and is expanding all the time, it is impossible to obtain a stock valuation without the computer. This meant that, in the past, Sterry never actually knew whether he was making a



Hobby Horse employees in the wholesale and mail-order side of the business.

loss or a profit. The bank balance might well have been increasing, but his stock might have been falling so fast that the company might really have been approaching bankruptcy.

Now the Pet tells him when stocks are low, what the stock value is, and what the period sales have been. Previously, a stock take would have occupied two full days, involved all the staff and then would have taken Sterry a week of checking the costs back to source. In theory, the computer can now do all that at the press of a button. In theory, because Sterry qualifies its effectiveness: "It's never quite accurate because things do slip through without being recorded. It should be correct to within 10 percent — which, believe me, is a great improvement".

Sterry also finds that the Pet has vastly improved the company's public relations while helpfully doing something about receivables: "All our debtors have an invoice printed-out by the computer, then a statement, and they really seem to think, 'He's really right on top of things now', and they pay more promptly".

Equally, Sterry can see who owes money more easily. In the pre-computer days he would have had to go through the ledger page by page looking for red ink to draw up any kind of a debtors' list.

The system does however have its limitations, and he is keen to stress that he does not idolise it, but there have been no really major disasters while he has been using the Pet: "We had a few discs which wouldn't copy, and in the past, I've been lazy about doing the back-up copies properly. But we've never lost more than a few days' work and at least we've always known what's been lost".

Not exactly the most rigorous approach to operating procedures for the computer, but at least it is clear that Peter Sterry and his system have come to some kind of understanding.

Apart from the price-list problem, the only real complaint that Sterry has about the software is the fact that it does not maintain a complete ledger for each customer — it only records details of the last transaction. That produces, however, a useful audit trail, and it would be possible to construct an automated ledger

from it if the Pet had more disc storage.

After his initial interest in micro-computing, Peter Sterry's views have matured somewhat into the kind of approach that typifies the first-time business user: "I think that micro-computers should be like television sets. I want to be able to press button one and watch BBC 1; I don't want to know how the television set works, all I really care about is receiving a good picture. Likewise, I'm not interested in the ins and outs of programming, I just want a machine which will do the job for me with a minimum of problems.

"To do that comprehensively on my system is impossible at the moment, because there just isn't enough memory for programmers to produce the kind of fail-safe programs that I would like to see, programs that do everything for you and which don't ever make mistakes. They would need far more memory than the current generation of micros seems able to offer. It's clear that the next generation will have considerable advantages, and they'll be able to be much more profligate with memory".

Typical day

The Hobby Horse computer is not exactly overused. It deals only with stock valuation, price lists, invoicing and statements: in a typical day it would do 12 invoices, change a few prices, update stock and record shop and mail order sales. Sterry now employs a part-time operator for a few hours a day on three days a week, for most of the input and anything very urgent he does himself.

"I think that I will eventually have to upgrade the system. Small systems are inherently less reliable and less flexible than bigger machines, and of course they can't do as much. Although I don't want to expand the business physically, I do want to continue increasing the turnover.

Sterry considers the costs he had borne — an outlay of some £2,500 for the Pet including software — a reasonable price to pay for the experience of learning about computers in business.

"When I buy a new system to do the complete ledger, I won't be at the mercy of any experts".

Counting manual methods out of the reckoning

FOR MANY small firms, stock control is a tedious and time-consuming job. One way around that problem is to use a computer to perform the task. You type-in on the computer the items you have removed from stock and periodically ask it for a list of the stock items requiring re-ordering. This program does just that and several other things as well. When run, the program displays a menu on the screen and will wait for you to type a command key from A to G.

Key A is pressed to type the items you have removed from the stock. Each item has a number to identify it which must be input

by Tony Edgecombe

during this part of the program. The amount removed from stock is entered. If the item was on the file, the program will continue to input the stock removals until all of the removed stock has been typed-in. If you make a mistake, however, and type a stock number which is not on the file, the program will display an error message and you will have to re-type the information.

The command key B is pressed to enter all of the stock that

has been re-ordered. If you make a mistake, the program will again display an error message and the information will have to be re-typed.

When new stock items are introduced, they can be added to file using the command key C. Four variables have to be input into the system:

- A Stock number
- B Amount in stock
- C Minimum amount allowed in stock
- D Amount to be re-recorded when stock is too low

Once this data has been input, it will be printed on to the end of the file.

When a stock item has to be modified or will not be used again, it can be deleted by using the command key D. If the item is not on the file the program will tell you so. Periodically, the stock will have to be re-ordered. By keying E, all of the stock requiring ordering will be printed along with the amount to be ordered.

For some reason, the operator may wish to examine the details of a particular stock item. That can be done by using the command key F. The final key, G, terminates the program and leaves you in Basic.

```

100 LET M=10
110 DIM A$(72),B$(72),A(100,7)
120 FILES A
130 READ %1
140 LET I=1
150 MAT A=ZER
160 IF END% 1 THEN 180
170 MAT READ %1:I,A
180 FOR I=1 TO 20
190 PRINT
200 NEXT I
210 PRINT TAB(5);"STOCK CONTROL"
220 PRINT TAB(5);"-----"
230 PRINT
240 PRINT "1. INPUT NEW STOCK ITEM"
250 PRINT
260 PRINT "2. PRINT DETAILS OF STOCK ITEM"
270 PRINT
280 PRINT "3. DELETE OLD STOCK ITEM"
290 PRINT
300 PRINT "4. TYPE REMOVED STOCK"
310 PRINT
320 PRINT "5. TYPE STOCK ON ORDER"
330 PRINT
340 PRINT "6. TYPE STOCK RECEIVED"
350 PRINT
360 PRINT "7. PRINT ITEMS REQUIRING REORDERING"
370 PRINT
380 PRINT "8. FINISH STOCK CONTROL"
390 PRINT
400 PRINT
410 INPUT I
420 IF I<1 OR I>8 OR I<>INT(I) THEN 180
430 GOTO I OF 440,740,930,1060,1160,1270,1380,1570
440 PRINT
450 PRINT "PRODUCT NUMBER:"
460 INPUT A
470 FOR I=1 TO M
480 IF A(I,1)=A THEN 530
490 IF A(I,1)=0 THEN 570
500 NEXT I
510 PRINT "OUT OF SPACE"
520 GOTO 180
530 PRINT
540 PRINT "INCORRECT PRODUCT NUMBER"
550 PRINT
560 GOTO 180
570 PRINT "AMOUNT IN STOCK ";
580 INPUT A(I,2)
590 LET A(I,1)=A
600 PRINT "QUANTITY ON ORDER:"
610 INPUT A(I,3)
620 LET A(I,4)=A(I,2)+A(I,3)
630 PRINT "RE-ORDER LEVEL ";
640 INPUT A(I,5)
650 PRINT "RE-ORDER QUANTITY ";
660 INPUT A(I,6)
670 PRINT "SUPPLIER NUMBER ";
680 INPUT A(I,7)
690 PRINT
700 PRINT "ARE THERE ANY MORE NEW ITEMS (Y/N)";
710 INPUT A$
720 IF A$="Y" THEN 440
730 GOTO 180
740 PRINT
750 PRINT"PRODUCT NUMBER:";
760 INPUT A
770 FOR I=1TOM
780 IF A(I,1)=A THEN 810
790 NEXT I
800 GOTO 530
810 FOR J=1T021
820 PRINT
830 NEXT J
840 PRINT"PRODUCT NUMBER      ";A(I,1)
850 PRINT"PHYSICAL STOCK      ";A(I,2)
860 PRINT"QUANTITY ON ORDER    ";A(I,3)
870 PRINT"FREE STOCK              ";A(I,4)
880 PRINT"RE-ORDER LEVEL         ";A(I,5)
890 PRINT"RE-ORDER QUANTITY      ";A(I,6)
900 PRINT"SUPPLIER NUMBER         ";A(I,7)
910 PRINT
920 GOTO 210
930 PRINT"PRODUCT NUMBER:";
940 INPUT A
950 FOR I=1TOM
960 IF A(I,1)=A THEN 990
970 NEXT I
980 GOTO 530
990 FOR J=I+1TOM
1000 FOR K=1T07
1010 LET A(J-1,K)=A(J,K)

```

(continued on next page)

(continued from previous page)

```

1020 NEXT K
1030 NEXT J
1040 LET A(J,1)=0
1050 GOTO 180
1060 PRINT"PRODUCT NUMBER";
1070 INPUT A
1080 FOR I=1TOM
1090 IF A(I,1)=A THEN 1120
1100 NEXT I
1110 GOTO 530
1120 PRINT"AMOUNT REMOVED";
1130 INPUT A
1140 LET A(I,2)=A(I,2)-A
1150 GOTO 1250
1160 PRINT"PRODUCT NUMBER";
1170 INPUT A
1180 FOR I=1TOM
1190 IF A(I,1)=A THEN 1220
1200 NEXT I
1210 GOTO 530
1220 PRINT "AMOUNT ON ORDER";
1230 INPUT A
1240 LET A(I,3)=A(I,3)+A
1250 LET A(I,4)=A(I,2)+A(I,3)
1260 GOTO 180
1270 PRINT"PRODUCT NUMBER";
1280 INPUT A
1290 FOR I=1TOM
1300 IF A(I,1)=A THEN 1330
1310 NEXT I
1320 GOTO 530
1330 PRINT "AMOUNT RECEIVED";
1340 INPUT A
1350 LET A(I,2)=A(I,2)+A
1360 LET A(I,3)=0
1370 GOTO 1250
1380 FOR I=M-1TO1 STEP -1
1390 FOR J=1TOI
1400 IF A(J,7)<A(J+1,7)THEN 1460
1410 FOR A=1TO7
1420 LET B=A(J,A)
1430 LET A(J,A)=A(J+1,A)
1440 LET A(J+1,A)=B
1450 NEXT A
1460 NEXT J
1470 NEXT I
1480 PRINT "PRODUCT", "ORDER AMOUNT", "SUPPLIER"
1490 FOR I=1TOM
1500 IF A(I,4)>A(I,5)THEN 1530
1510 IF A(I,1)=0 THEN 1530
1520 PRINT A(I,1),A(I,6),A(I,7)
1530 NEXT I
1540 FOR I=1 TO 10000
1550 NEXT I
1560 GOTO 180
1570 LET I=1
1580 READ %I
1590 MAT PRINT%I;I,A
1600 END

```



DISTRIBUTORS

AVON

CSS Ltd Tel: 0272 779452
 Wilkes Computing Ltd Tel: 0272 290651
 Computerama Ltd Tel: 0225 333232

BERKSHIRE

Riva Terminals Ltd Tel: 03447 5193
 Computershop Limited Tel: 0734 481555

CAMBS

Comart Ltd Tel: 0480 215005

CORNWALL

Exleigh Business Machines Ltd Tel: 0736 66577

DERBYSHIRE

Midlectron Ltd Tel: 077 382 6811

DEVON

A C Systems Ltd Tel: 0392 71718
 JAD Ltd Tel: 0752 62616

DUMBARTONSHIRE

Kode Services Ltd Tel: 0342 22766

FIFE

CS Scotland Ltd Tel: 0592 773710

GLAMORGAN

Computer Centre Ltd Tel: 0792 460023

HAMPSHIRE

Microchips Ltd Tel: 0962 62208
 Business Electronics Ltd Tel: 0703 738248

HERTFORDSHIRE

Electroplan Ltd Tel: 0763 41171

HEREFORDSHIRE

Famplan Ltd Tel: 0983 4321

ISLE OF WIGHT

Zeta Dynamics Ltd Tel: 0983 527725

LANCASHIRE

Keytech Eng Ltd Tel: 061 834 9244
 Preston Computer Centre Ltd Tel: 0772 57684
 Stack Computer Services Ltd Tel: 051 933 5511

LONDON

Compshop Ltd Tel: 01 441 2922
 DDT Ltd Tel: 01 207 1717
 Capital Computer Systems Ltd Tel: 01 637 5551
 CSS Ltd Tel: 01 254 9293
 Euro Calc Ltd Tel: 01 729 4555
 Interam Ltd Tel: 01 834 0261
 London Computer Centre Ltd Tel: 01 338 5721
 Sumlock Bondain Ltd Tel: 01 250 0505
 Small Systems Eng Ltd Tel: 01 328 7145

MIDLOTHIAN

Microcentre Ltd Tel: 031 5567354

NOTTINGHAMSHIRE

Keen Computer Ltd Tel: 0602 583254

OXFORDSHIRE

Orchard Electronics Ltd Tel: 0491 35529

SOUTH GLAMORGAN

Data Type Ltd Tel: 063 33 65307

SURREY

Peripheral Hardware Ltd Tel: 01941 4806
 AERCO Gemsoft Ltd Tel: 048 62 22881

STRATHCLYDE

Robox Ltd Tel: 041 221 5402

WARWICKSHIRE

Linbrac Computer Services Ltd
 Tel: 092 681 4539
 Taylor Wilson Systems Ltd Tel: 05645 6192

WILTSHIRE

Kode Services Ltd Tel: 0249 813771

Mind your own business...



Join over 25,000 farmers, scientists and businessmen from all areas of industry and commerce who already benefit from the cost-effectiveness of Anadex printers – rugged, versatile printers that give years of trouble-free service now operating in applications ranging from the controlled comfort of an air-conditioned office to the rigours of the sea.

Write or phone us for further details.

Prices range from £495 for the DP-8000 series and £795 for the new DP-9000 models to £895 for the larger DP-9500. Substantial discounts offered for OEM quantities.

...with a little help from

Anadex Ltd.

Details from Anadex Limited, Weaver House, Station Road, Hook, Basingstoke, Hants.

Tel: Hook (025672) 3401 Telex: 858762 Anadex G.

ANADEX OVERSEAS DISTRIBUTORS

AUSTRIA Fa. William E. Hayward Tel: (06222) 20026 Telex: 633336 BELGIUM Telerex NV SA Tel: (031) 833350 Telex: 33511 DENMARK Instrutek Tel: (05) 611100 Telex: 61656
EIRE Kode Services Ltd Tel: 01 802797 FINLAND Jertec Oy Tel: (90) 585 133 Telex: 123265 FRANCE Euroterminal Tel: (1) 665 7340 Telex: 201077
GERMANY Neumuller Messtechnik Tel: (089) 61181 Telex: 522106 Schwind Datentechnik GmbH Tel: (089) 8349716 Telex: 213097 ISRAEL SDSI Ltd Tel: (04) 667942 Telex: 4633 667948
ITALY Transport SpA Tel: (02) 34 92 941 Telex: 313178 NETHERLANDS Telerex Nederland BV Tel: (04998) 74295 NORWAY A/S Kjell Bakke Tel: (02) 711872/715330 Telex: 19407
SOUTH AFRICA Data Display (Pty) Ltd. Tel: (011) 678 5450 SPAIN Data Dynamics Espana SA Tel: (91) 408 00 00 Telex: 23534
SWEDEN Lagercrantz Elektronik AB Tel: (0760) 86120 Telex: 11275 SWITZERLAND EM Electronic Marketing AG Tel: (061) 35 36 37 Telex: 64861

New! Sinclair ZX81 Personal Computer.

Kit: £49.⁹⁵ complete

**Reach advanced
computer comprehension
in a few absorbing hours**

1980 saw a genuine breakthrough – the Sinclair ZX80, world's first complete personal computer for under £100. At £99.95, the ZX80 offered a specification unchallenged at the price.

Over 50,000 were sold, and the ZX80 won virtually universal praise from computer professionals.

Now the Sinclair lead is increased: for just £69.95, the new Sinclair ZX81 offers even more advanced computer facilities at an even lower price. And the ZX81 kit means an even bigger saving. At £49.95 it costs almost 40% less than the ZX80 kit!

Lower price: higher capability

With the ZX81, it's just as simple to teach yourself computing, but the ZX81 packs even greater working capability than the ZX80.

It uses the same micro-processor, but incorporates a new, more powerful 8K BASIC ROM – the 'trained intelligence' of the computer. This chip works in decimals, handles logs and trig, allows you to plot graphs, and builds up animated displays.

And the ZX81 incorporates other operation refinements – the facility to load and save named programs on cassette, for example, or to select a program off a cassette through the keyboard.

Higher specification, lower price – how's it done?

Quite simply, by design. The ZX80 reduced the chips in a working computer from 40 or so, to 21. The ZX81 reduces the 21 to 4!

The secret lies in a totally new master chip. Designed by Sinclair and custom-built in Britain, this unique chip replaces 18 chips from the ZX80!

**Built:
£69.⁹⁵**
complete

**Kit
or built –
it's up to you!**

The picture shows dramatically how easy the ZX81 kit is to build: just four chips to assemble (plus, of course the other discrete components) – a few hours' work with a fine-tipped soldering iron. And you may already have a suitable mains adaptor – 600 mA at 9 V DC nominal unregulated (supplied with built version).

Kit and built versions come complete with all leads to connect to your TV (colour or black and white) and cassette recorder.



Proven micro-processor, new 8K BASIC ROM, RAM – and unique new master chip.



New BASIC manual

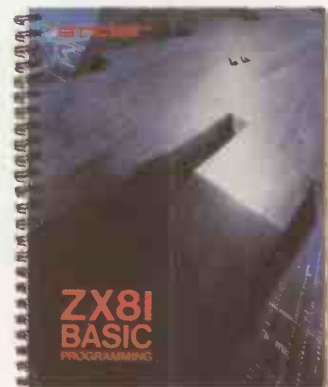

Every ZX81 comes with a comprehensive, specially-written manual – a complete course in BASIC programming, from first principles to complex programs.

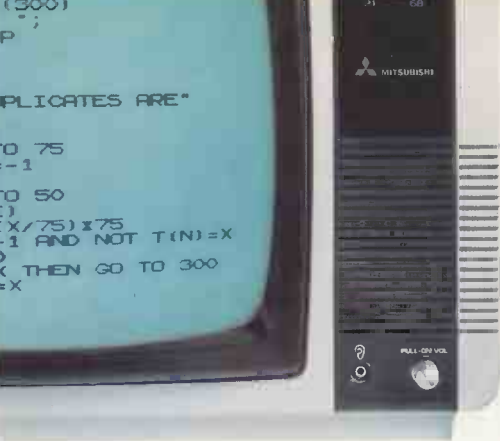

If you own a Sinclair ZX80...

The new 8K BASIC ROM used in the Sinclair ZX81 is available to ZX80 owners as a drop-in replacement chip. (Complete with new keyboard template and operating manual.)

With the exception of animated graphics, all the advanced features of the ZX81 are now available on your ZX80 – including the ability to drive the Sinclair ZX Printer.

Coming soon – the ZX Printer.

Designed exclusively for use with the ZX81 (and ZX80 with 8K BASIC ROM), the printer offers full alphanumeric across 32 columns, and highly sophisticated graphics. Special features include COPY, which prints out exactly what is on the whole TV screen without the need for further instructions. The ZX Printer will be available in Summer 1981, at around £50 – watch this space!



16K-BYTE RAM pack for massive add-on memory.

Designed as a complete module to fit your Sinclair ZX80 or ZX81, the RAM pack simply plugs into the existing expansion port at the rear of the computer to multiply your data/program storage by 16!

Use it for long and complex programs or as a personal database. Yet it costs as little as half the price of competitive additional memory.



New, improved specification

- Z80 A micro-processor – new faster version of the famous Z80 chip, widely recognised as the best ever made.
- Unique 'one-touch' key word entry: the ZX81 eliminates a great deal of tiresome typing. Key words (RUN, LIST, PRINT, etc.) have their own single-key entry.
- Unique syntax-check and report codes identify programming errors immediately.
- Full range of mathematical and scientific functions accurate to eight decimal places.
- Graph-drawing and animated-display facilities.
- Multi-dimensional string and numerical arrays.
- Up to 26 FOR/NEXT loops.
- Randomise function – useful for games as well as serious applications.
- Cassette LOAD and SAVE with named programs.
- 1K-byte RAM expandable to 16K bytes with Sinclair RAM pack.
- Able to drive the new Sinclair printer (not available yet – but coming soon!)
- Advanced 4-chip design: micro-processor, ROM, RAM, plus master chip – unique, custom-built chip replacing 18 ZX80 chips.

How to order your ZX81

BY PHONE – Access or Barclaycard holders can call 01-200 0200 for personal attention 24 hours a day, every day. **BY FREEPOST** – use the no-stamp-needed coupon below. You can pay by cheque, postal order, Access or Barclaycard. **EITHER WAY** – please allow up to 28 days for delivery. And there's a 14-day money-back option, of course. We want you to be satisfied beyond doubt – and we have no doubt that you will be.

sinclair
ZX81
Sinclair Research Ltd,
6 Kings Parade, Cambridge, Cambs.,
CB2 1SN. Tel: 0276 66104.
Reg. no: 214 4630 00.

To: Sinclair Research Ltd, FREEPOST 7, Cambridge, CB2 1YY.

Qty	Item	Code	Item price £	Total £
	Sinclair ZX81 Personal Computer kit(s). Price includes ZX81 BASIC manual, excludes mains adaptor.	12	49.95	
	Ready-assembled Sinclair ZX81 Personal Computer(s). Price includes ZX81 BASIC manual and mains adaptor.	11	69.95	
	Mains Adaptor(s) (600 mA at 9V DC nominal unregulated).	10	8.95	
	16K-BYTE RAM pack(s).	18	49.95	
	8K BASIC ROM to fit ZX80.	17	19.95	
	Post and Packing.			2.95
TOTAL £				

Please tick if you require a VAT receipt

*I enclose a cheque/postal order payable to Sinclair Research Ltd, for £ _____

*Please charge to my Access/Barclaycard account no. _____

*Please delete/complete as applicable. Please print.

Name: Mr/Mrs/Miss _____

Address _____

FREEPOST – no stamp needed. PRC05

we would like to tell you about the LIVEPORT low cost WP package in just two words

Automatic text wrap around.

When you are typing in text, you don't need to worry about where you are on a line, or when to type in a carriage return. The Word Processor automatically arranges the text into lines for you.

Single key control functions.

The control functions you use most often are available instantly, at the touch of a single key. These include INDENT, TAB, SOFT HYPHEN (for splitting syllables at the end of a line), and SCAN (for rapidly moving the cursor to either end of the current line). There are also four convenient cursor movement keys (UP, DOWN, LEFT and RIGHT) which automatically repeat if held down.

Minimum keystroke editing functions.

The main editing functions involve the least possible number of keystrokes—generally only two. Thus to delete any character(s) under the cursor, you simply press the DELETE function key the appropriate number of times. Then the CLEAR key is pressed to close up the text around the deletion. Similarly if you want to add a letter, word or sentence into the middle of your text, you simply move the cursor to the position required and press the EXPAND key. This opens up a "window" into which you can type the additional material. When you have finished, you just press the EXPAND key again to close up the text around the addition. Correcting mistyped characters simply involves positioning the cursor over the characters involved and retyping them.

Automatic checking of drastic commands.

If you type in a potentially drastic command (like a command to delete part of your file, or kill the entire file), the Sorcerer Word Processor will automatically query you before it carries out the command—by asking "REALLY?". Only if you type Y for yes does it go ahead and execute the command. This protects your files against accidental damage.

Powerful special functions.

The Sorcerer Word Processor provides some really powerful special editing functions. One of these is the Marker function, which lets you insert non-printing "marker" characters in your text to identify places where future changes are needed. Then when you want to make the changes, you can tell it to jump to the next marker (either forward or backward in the text) simply by entering a 2-keystroke command. There is also a Search and Replace function, where you can tell the processor to search for a specific string of characters (say a persons' name) and replace it with another string. This can be done repetitively, so that the string is replaced whenever it occurs in the text, and you can have the processor either replace the string at all locations automatically, or stop at each location to give you the option of skipping over it. You don't even have to specify all of the string to be replaced, you can specify either all 7 letter words ending in 'ing', for example, or all 12 letter words beginning with 'anti'. The processor also provides a holding buffer, separate from the main text buffer, where you can store material from one file for use in another.



**Just cut and post the coupon
and we'll send you
our final word!**

I am interested in your low cost word processor & computer—please tell me more . . .

Name _____

Address _____

Tel No. _____

LIVEPORT
DATA PRODUCTS

The Ivory Works, St. Ives, Cornwall TR26 2HF
Telephone: (0736) 798157

PCE
90

Micros find important role at heart of large-scale industry

A MAJORITY of microcomputer applications we see in use or whose software we hear about is for small businesses. Large-scale heavy industry tends to have a great deal of computing power already, and full-time dp departments. Such micro-based equipment as they dispose of may be outlandish to the amateur, who sees little connection between the desk-top machine

by Martin Hayman

on which he plays Dungeons and Dragons and the much-trumpeted robots of a Fiat assembly shop. Yet the micro can still be used, in a more or less standard fashion, to improve industry's profitability.

This much is shown by a visit I paid recently to Marconi Space and Defence Systems in Portsmouth, where systems analyst Des Breach has installed a multi-user Altos micro system with four terminals to tidy up the running of the factory's £5 million machine shop. Building and using machine tools has long been a field in which the British have claimed pre-eminence, though much of the equipment at Marconi is in fact U.S.-built.

It is, of course, precisely this area of industry which has received some of the recession's worst battering. High interest rates have made it very desirable to either maximise the productivity of existing plant or make intelligent and economical plans for replacing it — preferably both.

Marconi is better placed than many smaller concerns since it has many Government contracts which were placed some time ago and which are still providing work. Components for defence equipment are still needed, since this is one area in which there have been few spending cuts. The fear that all the fat has been burned off industry and that it is now losing its muscle does not seem to be shared by people I talked to at the Marconi Broad Oak Works.

Machine tools are generally operated by numerical control, NC. Paper tapes are typed on IBM typewriters with paper-tape readers and punches. These tapes are fed to an optical reader which translates them into machine instructions — move the cutter of a lathe so-and-so far along the longitudinal axis of the workpiece, so-and-so far on the horizontal — and so on. This final stage, which in former times, before the introduction in this country of NC, would have been performed by hand by a machine operator, is now achieved by hydraulics and reciprocating ball screws.

That aspect of machine-shop work usually runs well, but machines break down and job priorities change mid-run,



An Altos multi-user system.

requiring that one machine be re-programmed for a different job, with a different paper tape. Obviously, once a tape has been used and is effective for a particular component, it is stored so it can be used again in the future with a magnetic tape back-up copy.

Highly specialised

Many of Marconi's jobs are, however, highly specialised and only a short run is needed. What happens if a machine breaks down in the middle of a job and there is no tape for use on a different machine? The tape must be re-written for a different machine.

In the past, that had caused considerable delays at Broad Oak Works. It was not necessary to convert programs manually, which would have taken an age, but the Transdata 4000 terminal linked by telephone to an IBM mainframe at Marconi headquarters in Chelmsford, Essex, was not altogether a satisfactory solution. The IBM does indeed convert programs, but was available only during office hours, whereas the Broad Oak Works in Portsmouth functions on a shift system, working from 6am to 10pm — there were bound to be breakdowns when the mainframe was not running.

There were also further inconveniences: new program development work required the Transdata to drive a plotter. Sometimes such work would be interrupted two or three times a day when a conversion routine required that the Trans-

data talk to the Chelmsford mainframe — time-wasting, since the run would have to be re-started from scratch.

However, such are the economics of this kind of operation that it is judged better to waste programmers' time than machine time, which on the largest milling machines is costed at £28 per hour. Even so, machine-floor downtime is calculated at 15 percent.

Eventually, the IBM typewriters, on which the fundamental paper-tape development work was done became due for replacement. An identical set-up was going to cost around £9,000. Des Breach asked himself why a micro, or several micros, could not be bought for the same money and used to improve flexibility and free his department from dependence on the Chelmsford mainframe link and from its attendant frustrations for program development. Micros would have better editing facilities, would be less noisy, and would offer a host of other advantages.

Breaking new ground

Although Marconi is, of course, a micro-processor manufacturer, its products tend to be for dedicated applications and it does not manufacture any kind of micro itself; and nor is there a ground-level policy for microcomputer acquisition. Hence Des Breach found himself breaking new ground when he proposed to replace the IBMs with the machine which he had winnowed from the

(continued on next page)

(continued from previous page)

rest as the most suitable for the job. He had to go to headquarters to argue the case for the Altos machines, which would be paid for from the plant acquisition funds.

Why Altos? I asked Breach: "At the time I started looking, at Compec two years ago, there wasn't a great deal available in the multi-user field; we wanted to keep compatibility with the Transdata, which had been installed by my predecessor, but using mini-floppies. It also had to be based on the 8080 processor".

To a great extent, then, his decisions were based on ensuring continuity with an existing system which had been chosen for its IBM communications protocol to talk to the mainframe and had facilities for NC. This last feature, caused some headaches with the Altos, which is interrupt-driven; they had to be disabled to interface with the paper-tape writers, which need to be continuously driven. Yet, so far as he was concerned, it was all part of a "reasonably, obvious way to go", shifting from dumb terminals to intelligent ones.

The Altos machines were supplied in the normal commercial way, by the local Altos agent, Profac Computer Services in Camberley, Surrey. The Altos itself is a U.S. machine, the main agency for which is held by nearby Logitek of Chorley, Surrey. Profac's Jim Reid installed the system which operated on MP/M 1.12, and wrote some of the software to adapt it for the NC application, though Des Breach says that he had to tune it a little before he could rely on it.

Ultimately, there is no reason that the micro should not control the machine tools directly, without the need for the intermediate paper-tape stage, but this is surely some way in the future. At the moment, each user can call routines from a common base of subroutines, which is much more efficient and less frustrating than queuing for the mainframe.

Race of inventors

Neither Jim Reid nor Des Breach seemed surprised that Marconi, as a British microelectronics manufacturer, should be buying micros from the States; they look at it in the same way as buying a typewriter or photocopier, which would equally likely be U.S.-built. "We are a long way behind the U.S. in terms of building micros, but we can catch up in the area of applications and industrial control — we are, after all, a race of inventors", claims Jim Reid, who admits that he is very keen to win the order from Marconi.

The Altos system is used for four principal tasks: preparation and editing of paper tapes; conversion of tapes for different machines; prior plotting of completed tapes; and calculation of run times for costing purposes. The design process works like this: a blueprint for an assembly arrives at the Broad Oak Works.

It is assigned to one of the drawing office staff, who sits down at a board and with the skill of knowledge and experience, calculates roughly how best the machine tool should make the passes over the billet of raw material.

These billets are usually of high-grade alloy, and extremely expensive. The blueprints, along with materials' specification are straight from the design office at Stanmore or from the Ministry of Defence. Usually, there will be no indication as to what kind of component it is, or to what machine it belongs. This is a curious aspect of the work at Broad Oak, where everybody signs the Official Secrets Act.

After deciding what kind of machine — there are two types, milling machines and lathes — the drawing office engineer moves on to the paper-tape punch, or the Altos if he can program it, or if neither, then writes it all on a process form. He may at this stage be assisted by the mainframe which will define the geometry of the part.

This stage of the work is usually done in APT language and entered on to one of the Altos machines by the NC engineer. It is stored on an Altos hard disc and sent via Des Breach's own software to the Transdata 4000, configured as an internal terminal, and loaded on to its 8in. single-density floppies. This machine can then talk to the IBM 3032 or 370 — at a price. As in many large companies, services are internally billed, so there is an element of cost-saving, too, in the processing power introduced by the Altos set-up.

There are two stages here: the intermediate processor, which defines the basic geometry of the part, and the post-processor, "which does the frilly bits to interface with each controller". The design of a component can involve elaborate and lengthy calculations: for example, the specification for the part may require an elliptical external section and a wall thickness of such-and-such. Interpreting these criteria involves a good deal of computation since the internal section will not in fact be elliptical.

When the paper-tape image is returned over the line from Chelmsford, Des Breach's department sets to work to put in as many safety checks as possible. APT itself is a well-trying language and unlikely to introduce errors but post-processor routines can be prone to errors until they are thoroughly de-bugged — in some cases this has taken as long as three years. They are long programs, usually supplied by the machine-tool manufacturer but refined in the light of experience.

The paper-tape routine so created is then read on to the Altos which drives a Hewlett-Packard plotter to give a physical representation of the passes a cutter will make on a particular workpiece.

Here there is no substitute for experience. It takes a trained eye to spot an abnormality in a plot, but in this kind of application there is literally no margin

for error. With a £3,000 billet of high-grade alloy flying around on a lathe, a wrong routine which sends the cutter in at an impossible angle can cause grievous injury to man and machine if the chuck bolts shear.

Even though every test is preceded by a "fresh-air pass", the proof of the program is in the slicing. "I don't think you'll find any programmer who won't admit to a 50 percent increase in heart-rate every time at a try-out", Breach's colleague Jim told me. "It might be six or nine months since you wrote the program that the job is tried on the shop-floor, and it's a fraught moment. You know that if you've missed out a zero somewhere, something catastrophic could happen". In the background lurks the possibility of a power failure: "A power cut is enough to wipe out a RAM and if the processor goes wild, so does the machine".

Spectacular time-savings

Some of the time-savings made by the Altos are spectacular. Translating instructions for one machine for another involves re-sequencing blocks of commands; it may be one, several, or all the blocks. One program searches for a block and re-sequences the numbers. Where previously it might have taken a morning to re-sequence 400 blocks, it can now be done at a rate of three minutes for 1,000 blocks. Where a complete routine on the biggest milling machine, the ZIP might take 9.5 hours to plot on the Transdata, it can now be done in 4.5 minutes. Best of all is the low-cost time-sharing, where a plotter program can continue uninterrupted while the essential converter programs are run.

Des Breach says that, to his knowledge, it is the first application of a micro system in this kind of numerical-control machine-shop. Others will doubtless disagree — I am told that Cincinnati Millicron in the States does just this, though I've a feeling it probably uses a dedicated micro-processor rather than just an adapted off-the-shelf micro. What is especially interesting about the Marconi installation at Broad Oak Works is that the micro which is bought straight from a retailer can be used to improve radically the performance of heavily capitalised plant.

After all, the first cost of the micro system works out at something like 0.2 percent of the machines on the shop-floor. It is vaguely disquieting, though, that these ideas must struggle up from the grassroots, and that there exists no overall policy in a firm which specialised in electronics, to use micros wherever possible.

It is reassuring, though, that once Des Breach, had argued his case, this kind of equipment has been approved for future use on other Marconi plants. Even if the hardware is American, at least the ingenuity which brings it to life is homegrown. □

Ethernet or Cambridge Ring?

THERE ARE fashions in communications technology, as there are fashions in anything else. If you had said data communications in the mid-sixties, the technology gurus would have immediately responded by discussing two problems, problems whose solutions they would then tell you were "just round the corner". The first was the high-speed transfer of large files, sited as remotely from each other as possible.

The second problem was that of real-time interactive computing — a problem which was in practice of concern only to defence and airlines, for most of commercial computing was still largely batch. Where there was interactive traffic, most of it was still low speed — about 300 baud. The VDU was nowhere near so ubiquitous; users in the main worked with Teletypes or Teletype-like terminals, and response times were slow.

By the late-sixties and early-seventies, the fashionable talk concerned networks and resource sharing, either nationwide or on a continental scale. It was the start of the era of packet switching and of the concept of resource sharing. We would soon, we were told, be able to share computer resources irrespective of distance or manufacturer's name tag.

In the mid-seventies, the literature was suddenly full of star networks and communications architecture was all the rage: how did a manufacturer make its systems talk to each other; what communications could it offer the market?

Satellite communications

That was followed rapidly by the question of satellite communications. Satellite communications became a common topic long before the major manufacturers had arrived at suitable communications architectures.

The first ideas about satellite communications proposed star networks, with an orbiting central node. At first sight this may seem odd. Is not after all one of the major characteristics of a satellite that when it broadcasts, any ground station may communicate with any other point also so equipped? That may be so, but it is not how the use of satellites was initially envisaged. It was looked at as a method of high-speed, high-volume communications between headquarters, and outlying branches, plants and offices — a method of reinforcing central control.

That may, of course, have been a reflection of the initial military communications uses to which satellite communications were put. However, with satellites emerged a difference — the experts were talking about the management of all communications. If you could send data, why not also voice, facsimile, and image.

Of course, as the initial satellite ground-stations were likely to be costly, we had returned to the area of shifting mass volumes. The larger the volumes, the better the economics looked.

Meanwhile, the fashion has changed yet again. The next bandwagon is the local communications network. Such is the pace of the bandwagon that SBS has already stated that it will eventually provide a service to link local communications networks via satellite.

Yet why such networks at all? Why not continue as we are doing now? Such

by Rex Malik

networks have their origins both in technology and economics. In the technology, because as solutions began to be found for the long-distance networking problem, it became apparent that many of the real problems were no longer concerned with long-distance transmission, but with much shorter distances.

The concept of distributed computing was beginning to take hold and even where it had not, organisations now had many devices to link to each other or to CPUs. The problems needing solutions were now the linking of devices locally to access the communications medium, and the efficient use of that medium.

Now, a new discipline enters. It is known as communications analysis and management. That it exists at all is hardly recognised yet, but it can be seen more and more particularly in large, international operations, in technologically-aware companies and organisations.

It is the result of three pressures: costs, technology, complexity. Communications costs have been increasing, partly because of inflation, partly because of massive investment programmes by post offices internationally. Visible communications costs have, too, been increasing with continual substitution of machine power for man power.

The export revolution of the last 20 years has meant that more and more communications take place and often over longer distances. Thus 20 years ago, British industry only dabbled in the U.S. market, while the amount of trade with the Far East was low.

Second, technology: the amount of technology in communications has increased. Then — 20 years ago — there were only posts, telephone, Telex. Today, there are posts, telephone, Telex, data, facsimile. Direct-dialling internationally has arrived, and there are now a wide variety of services available within each category, and an even wider range of devices.

Third, the result of this has been an increase in complexity. Not five years ago,

even in the best-managed companies, the communications function was handled by a low-level manager. He negotiated with post offices for data connections, telephone connections, and new Telex machines. The rest was beyond his control. The content of communications did not concern him, and neither did the fact that many of the devices for which he obtained links overlapped in function.

Now, mounting costs and new devices have given communications a new prominence in organisations which they never had before and have created a new management function; communications analysis and management. At its best, the new discipline tries to look at and quantify all forms of communication in an organisation and between that organisation and the outside world.

It measures the quantity and tries to assess the quality as well as investigating the costs. It is not just concerned with digital technologies, but also older methods still in use — internal mail, messenger services. It deals, too, with the newer technologies: how will word processing, image processing, video be used? Do we need intelligent digital exchanges? It deals with the future. The planning function has been added and it can now become a serious management job.

Few surprises

Communications analysis has produced surprises. Very few organisations knew — indeed, many still do not know — how much they spend on communications. This has been because communications bills were seldom identified and analysed before. Most costs were usually subsumed under the title of overhead, with one or two clearly identifiable expenses — most noticeable was the telephone bill.

As organisations have begun, however tentatively, to identify where the communications budget is spent, so the composition of that budget has been changing. Postal systems and messengers distributing paper around offices are being replaced increasingly by a need for computers, terminals, word processors and other devices to intercommunicate, for remote files to be accessed on line, and for printers somewhere in the organisation to output material.

The need to mix types of data if one is to build a local communications net which will provide solutions into the future, the mainstream digital technology trends, the types of devices which are appearing on the market, have all forced the network designer to make use of packet switching. Packet switching, for those not familiar with it, consists in essence of a technique for breaking data into packets of code,

(continued on next page)

(continued from previous page)

each of which carries an also coded address and other instructions.

Messages of whatever length are broken-up into packets, cast on to the network, and recognised by the device to which they are addressed — it has an interface — where they are collected and re-assembled into the full message or text.

Packet switching is, in principle, a technology which is transparent as far as the type of electronic communications is concerned. It can be data, voice, picture. What determines whether it is any one or all three is the bandwidth available. There are various ways of achieving such objectives using packet switching. Currently the two leading commercial candidates are the Cambridge Ring and Ethernet.

Ethernet was originally the product of Xerox. Ethernet Mark One was developed by Xerox at its Palo Alto, California laboratory, and was under development for seven years — with some use within Xerox — before it surfaced recently as a commercial product, the Mark Two, from Xerox, DEC, and Intel.

Image transmission

The Ethernet Mark Two is a 10 megabit per second data-rate system where Ethernet One was at three megabit. The Mark Two offers a capacity which will, in the relatively near future, permit image transmission and eventually also voice transmission.

The three companies are not, however, just selling equipment: they are also selling a standard — a way of doing things. They will be able to generate the volumes between them to make the economics acceptable. Thus Intel will do the basic LSIs, including that for the controller, while DEC will build the transceivers.

The Cambridge Ring also had its origins in a research laboratory, the computer laboratory of the University of Cambridge. It was devised to allow them to interconnect computers and similar devices, and by early 1979 they had inter-connected an experimental computer of their own, a PDP-7, two PDP-11s, a Nova, and LSI-4, a free-standing plotter, and a number of Z-80-based devices.

The Cambridge Ring has since been taken up by Cambridge-based Orbis Computers which has already shipped a trial installation to ICI at Runcorn, Merseyside, a four-node ring to which initially were attached an LSI-4 and a PDP-11. It has also since been taken up by Logica VTS, the word-processing arm of the Logica consultancy group. It is interested in its use largely in the context of office information systems.

So, how do Ethernet and the Cambridge Ring differ? Firstly, they differ in basic architecture. The Ethernet consists of a coaxial cable run through a site to which devices are then attached by

means of cable-TV-technology clamp connectors. There is no central control or switching mechanism.

All the attached devices listen all the time for passing packets. When the device recognises that a packet is addressed to it, it copies it into its own controller. The convention is that a packet with a zero address is taken to be broadcast and all linked devices then copy.

If a device wants to transmit a packet, it waits until there is no passing traffic. Provision is made to alert devices if a collision between packets has taken place. The switching functions are performed by the devices attached, leaving the Ethernet cable as a passive communications backbone.

In topology, the Ethernet can be thought of as an unrooted tree: unrooted, because it can be extended from any one point in any direction. New stations can tap in at any point, yet one avoids multi-path interference — there is, of course, always only one path between source and destination.

In terms of devices and parts, the Ethernet has four components. The cable or Ether; the transceivers which drive that Ether; a device-specific interface which does the packet switching calculations for the device; and a controller, firmware or software for sending the packets in and out of the Ether.

An example of Ethernet One at a very heavily loaded site had 120 hosts connected, including two time-sharing processors, a large number of personal computers, shared files, shared printers, and gateways to other sites. In a single day, it carried about 300 million bytes of data — the majority of packets are about 30bytes long — but the majority of volume is in much larger packets, about 500bytes.

The Cambridge Ring consists of a number of nodes connected cyclically to form a closed circuit. One part of each node is concerned with the regeneration of incoming data signals for onward transmission. To maintain this function when the station is not switched on, 28VDC is distributed around the ring from attached power supplies.

Ring cable in the Logica VTS version is telephone-grade, triple-twisted pair, with at present a maximum length between stations of 100m.

The Cambridge Ring is what is known as an empty slot ring. In it, data travelling around the ring is delayed — a delay can be thought of as temporary storage of data in transit. The circulating storage is so marked that it can be recognised as empty. To gain access to the channel, a station finds a slot currently marked empty, grabs it, marks the slot as full and loads its data.

When data is transmitted, it reaches the addressed receiver where it is copied. The packet with original data continues to go round the ring, however, and the packet is marked empty only by its

original transmitter. The receiver marks the packet as it passes, either accepted or rejected because busy. Two response bits are included in each packet which allow the detection of a third stage, namely that no station of that address was found. This stops packets which are wrongly addressed from circulating for ever.

To prevent a station from hogging all the empty slots on the ring, a round-robin scheme has been built into each station so that a returning used slot must be passed downstream and cannot be used immediately again by the same transmitting station. Provision has however, also been made for fast devices to communicate rapidly, while slow devices transmit at a speed which matches their output performance.

The Ring components are the stations — which include the repeater powered by the ring — logic which provides the interface and controls transmission and reception, access logic which is individual to the type of device and matches its interface to the station interface, slave power supplies, connectors, and a monitor. The monitor provides padding via a shift register of 40 bits. That is necessary in very short rings where there is insufficient cable and repeater delay to provide even one circulating empty slot.

Logica VTS is to produce a number of products which will include the ring components and devices to be attached to rings, including a ring bridge which will allow datagrams to be shipped between two rings, and a ring gateway which will allow data to be interchanged between the ring and X-25 networks.

It needs to be remembered that Logica VTS is primarily in the business of inter-communicating word processors. With current technology, it would not be unfair to write that all ring systems suffer one disadvantage: the usable packet length set against the size of the address and control bits is small. It is no disadvantage when considering the movement of computer data only, clever engineering can fix that.

Long-term solution

There is some doubt as to whether one could expect a ring system to meet all communications requirements within a single location. Ring systems are for situations where a decision has been made to concentrate most of the message traffic in digital computer-like devices. Or where indeed a ring on its own will repay its investment from the greater utility it gives to digital computer devices.

Not to be unfair, there is some doubt as yet as to whether Ethernet will provide the total answer. Or that if and when it does it will be recognisably Ethernet as we know it. All that we can say is that both are brave attempts to answer at least part of the problem. The long-term solution in which one communications medium is transparent to all forms of communication is still in practice some way away. □

INNOVATIVE

TRS-80 SOFTWARE

FROM THE PROFESSIONALS



We are pleased to be able to announce the commencement of a new series of Adventure games. The series named "Mysterious Adventures" is written in machine language by B. Howarth, an English author. The first episode is entitled "The Golden Baton". The scenario is that you have been sent by the ruler of your own land to a strange province with the mission of discovering the whereabouts of the legendary Golden Baton of Ferrenuil, King of the Ancient Elf Kingdom. The baton mysteriously disappeared several years ago and whilst others have ventured to the land in an attempt to discover it, none have returned to tell their tale!

The program follows what has become the normal structure for Adventure programs. Like the original main frame Adventure, directions can be designated by just the first letter of the compass point and commands may be optionally entered with just the first three letters of the appropriate word. As usual provision is made for saving the game at any stage and such standard commands as Help, Inventory, Score and Quit are all available. Experienced adventurers will inevitably draw comparisons between this series and that of Scott Adams, so we will leave it to them to make their judgements! The only comment that we will make at this time is that we find it quite invigorating to play an Adventure game by a different author as obviously they construct their stories slightly differently. Mysterious Adventure 1, "The Golden Baton" is available on cassette for TRS-80 or Video Genie machines of 16K or more and on disk for 32K up machines. It occupies a full 16K. The tape versions save their game to tape and the disk to disk.

Tape version£8.75

Disk version£11.00

Both prices plus VAT and 75p P. & P.

TRS-80 & VIDEO GENIE SOFTWARE CATALOGUE £1.00 [refundable] plus 50p postage.

A.J.HARDING (MOLIMERX)

MOLIMERX LTD.

1 BUCKHURST ROAD & 28 COLLINGTON AVENUE,
BEXHILL-ON-SEA, EAST SUSSEX.

TEL: [0424] 220391

TELEX 86736 SOTEX G

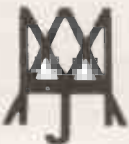

BARCLAYCARD



• Circle No. 168

COMPUTER

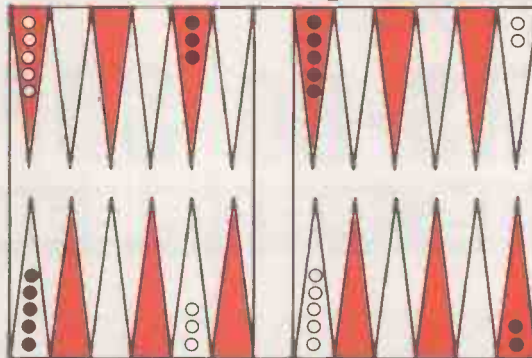

BACKGAMMON

A COMPUTER program has beaten the world champion backgammon player — the first time a computer has defeated a world champion at his own game. Unlike other strategic computer games, e.g., computer chess, the backgammon program used positional judgment rather than searching algorithms. Writing such a program presents an interesting problem for the hobbyist.

If you decide that you would like to use the code of a working program as a starting point, or prefer just to play the game, a Basic program for Pet is listed. The program is packed as tightly as possible and just fits on an 8K Pet. We can give only brief ideas on backgammon strategy; a number of books have been written on the subject and one of the most authoritative and readable is by Magriel.

Backgammon is a game for two played on a board divided in 24 regions, known as points, plus a central region, known as the bar. Each player starts with 15 pieces which are moved round the board according to the roll of a pair of dice. Eventually the pieces are removed from the board altogether. The game is won by either forcing one's opponent to resign or being the first player to remove all one's pieces from the board.

The stake, i.e., a number of units, won and lost for a single game may increase during the game, and if neither player resigns, the amount won depends on the distribution of the pieces of the losing player. Thus the objective of a game of backgammon is not just to win, but to win as many units as possible. The overall winner is the player who emerges with most units over a number of games.

Figure 1 shows a standard backgammon board with the pieces in the starting positions. The points have been numbered from 1 to 24 to aid description of the rules. Player A's pieces are represented by ● and player B's by ○. The bar is the central vertical region between points 6 and 7. The general direction for movement of B's pieces is from point 1 to point 24, whereas A's pieces go in the opposite direction — point 24 to point 1.

At each turn, you are required to attempt to make either two separate moves corresponding to the dice throws, or if the dice throws are equal, four separate moves. For example, suppose player B's throw was a six and a one in the starting position. He can either move one piece six places and another piece one place, e.g., a piece from point 12 to 18 and a piece from point 17 to 18, or alternatively, he can move one piece a total of seven places — though this must be done in two moves, e.g., a piece from point 12

by Bob Snell and
Barbara Colley

to 18 and then from point 18 to 19. Remember that if the dice throws are equal, you have four, and not just two, separate moves to make.

There is, however, the restriction that you must not move a piece on to a point occupied by two or more of your opponent's pieces. This restriction will mean that there will be times when you are unable to make full use of your dice throws. The rules that apply in this situation are:

- You must make full use of the dice throw if possible.
- If you can make only one move when two are normally required, you must use the higher throw if possible.

If you move to a point occupied by a single piece of your opponent, your opponent's piece is sent to the bar, which is equivalent to going to a point beyond the first point — 24 for player A or one for player B. A single piece on a point is called a blot and if it is sent back to the bar, the piece is said to have been "hit".

When you have a piece on the bar you are not permitted to move any other pieces on the board. It is essential, therefore, to move your pieces from the bar as soon as possible. As far as player B is concerned, the bar may be treated as point 0, e.g., for a throw of three he may move to point 3, assuming that point 3 is not occupied by two or more of his opponent's pieces. Similarly, player A can

assume that the bar is equivalent to the 25 point.

Removing your own pieces from the board is called "bearing off". To do it, you must first have all your pieces in your own inner table, i.e., on your last six points. For example, player B must have all his pieces occupying point 19 or higher. To bear off, player B can assume that he is trying to move to point 25, player A to point 0. Thus a throw of three will enable player B to bear off one piece from point 22.

If you have a throw which would normally enable you to bear off from a point which is now unoccupied by your pieces and there is none of your pieces further out, you must bear off from the furthest point occupied. For example, if player B throws a three and all his remaining pieces are on points 23 and 24, he must bear off from point 23.

At the beginning of the game, the basic stake is one unit. Either player may, however, before knowing his dice throw, opt to double the stake. His opponent has the choice of refusing the double, thereby conceding the game for the current stake, or accepting the double, in which case the game continues. The stake may be doubled again, but not by the player who last doubled.

The stake may also be doubled on the first throw of the game — one die per player — which is used to determine which player has the first move, the higher score earns this privilege. If the dice scores are equal, the stake is automatically doubled.

If one player refuses a double, the units won and lost are equal to the current stake. If the game ends because one player has borne off all his pieces, the units won and lost may be higher. If the loser has not borne off any piece and still has one or more pieces in his opponent's inner table — points 1-6 for player B, 19-24 for player A — the winner has backgammoned his opponent and has won treble the current stake.

If the loser has not borne off any piece but the winner does not qualify for a

backgammon, he has won a gammon which is worth twice the current stake. If the loser has borne off a piece, he loses only the current stake.

You can see from this that if you are heading for a gammon or backgammon, it is not prudent to offer your opponent a double thereby enabling him to escape with the loss of fewer units. A player may resign only when a double is offered to him.

The first consideration when designing an interactive program should be the user interface — in this case, how the mechanics of the game will be presented to the player. The player needs to know the current position and requires a method to input his moves, including the ability to offer a double at a suitable time and to reply when doubles are offered by the computer.

He must also be able to decide whether dice throws are to be generated automatically by the computer or manually by the player. To the programmer, it seems natural to make the program generate dice throws both for its own use and for the player. However, if the program is able to beat a particular player consistently there can be the doubt in the mind of the player confronted by a series of defeats that dice throws are being fixed for the computer's benefit.

Perhaps the answer is to allow an option at the beginning of the game so that the player may choose whether he wants to enter the dice throws for each move himself or to allow the computer to generate them.

With modern displays, it is possible to use eye-catching graphics to construct a diagram showing the current position of the pieces. However, we believe, like all serious game player-programmers, that the most important factor of a strategic game such as computer backgammon is how well the program plays rather than how good it is at telling you what it has done.

Pretty diagrams are all very well providing that their construction does not take perceptibly longer than a basic but adequate display, nor use valuable program space which otherwise would be available for improving strategy. What is acceptable depends on the size and capability of the computer used — clearly it is not the same for an 8K Pet and a 100K DEC-10.

A basic display, which can be reproduced on a printer, is shown in figure 2. The computer now takes the place of player A and its opponent of player B. One symbol is used for the computer's pieces and a second for the player's. Points are numbered for easy reference. Note that in theory, each point may contain up to 15 pieces. As shown in figure 2, if there are more than five pieces on a point, a digit is displayed. For representing 10 pieces, A is used, for 11, B is used and so on.

Moves can be input and output using

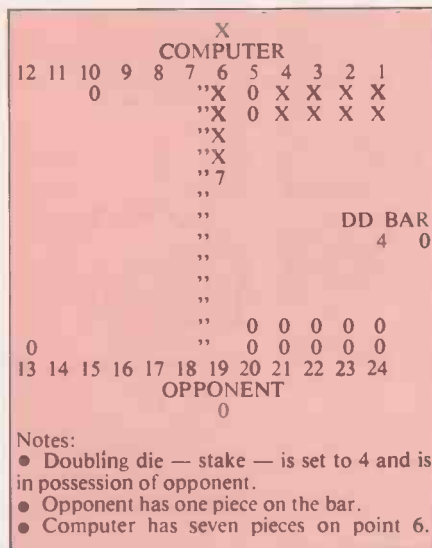

Figure 2. Simple computer display suitable for production on a Teletype.

point numbers. For the computer, 25 can be used to mean the bar and 0 for bearing off and *vice versa* for the player. In this way, each move may be individually represented.

It is also vital for the program to ensure that the rules of the game, which are precisely defined, are obeyed. Some writers of commercial programs take the view that if the player wants to cheat by entering an incorrect move, it is up to him — the program will not attempt to check. We absolutely abhor this attitude.

Firstly, it is of no help to the player learning the game if he is allowed to make illegal moves; in fact, even reasonably expert players are unaware of the application of the rules in certain cases, so even they can be helped. Secondly, the player may have entered an incorrect move by mistake. In this case, a perfectly good

game could be ruined by the program's inability to detect the error. It is vital that all moves, including null moves, are checked for validity and that doubling is permitted only at the appropriate time.

To simulate dice throws, a pseudo random-number generator is required. It is often already provided for the programmer by means of a function which outputs a real number between 0.0 and 1.0. A number thus obtained needs to be multiplied by six, truncated to an integer to which one is added to give a suitable throw. If a random number generator is not provided it is possible to write your own by using arithmetic to overflow values — see *Computer Simulation Techniques*.

Given that we can now generate a sequence of pseudo random numbers and hence dice throws, we still need to give different values for each game. That may be achieved by discarding some of the random numbers to give a different starting point in the sequence. The number to be discarded can be based on the current time, unless it is available on the computer being used, it must be input by the player.

The next item of software to write is the move generator. Given a particular dice throw and position, the move generator should be able to generate every valid move. Obviously, this can be done only by considering the scores of both dice.

This piece of software is probably the most difficult to write because the programmer must be certain that every possible position and move is catered for. It does not matter that the move generator gives a particular move more than once, providing that it is not taking too long over redundant moves. It matters greatly, however, if it omits to find a particular move. The move it omits could on some occasions turn out to be the best move or even the only move. Even worse than allowing the player to cheat is allowing the program to cheat.

Having written the move generator, the dice generator and the user interface, the programmer has the fundamental ingredients of the program. It is then necessary to write an algorithm which will choose the best move from those available. Although on average there are about 20 ways of playing a particular throw, there could be more than 1,000 possibilities. Depending on the computer being used, it may not be feasible to consider them all.

One way to write the program is to allow a certain number, variable between program runs, of move possibilities to be considered from those available. In this way, a program run might be geared to suit the level of competence of the player, e.g., the beginners' level might process two moves whereas the experts' level could allow up to 50 possibilities to be considered — even more if computer speed permits.

The normal way for the computer to select a move is for a value to be given to

(continued on page 99)

Table 1. Recommended opening moves by first player.

Throw	Move, computer	Throw	Move, computer
6-6	—	5-1	13-8, 24-23 or 13-8, 6-5
6-5	24-18, 18-13	4-4	—
6-4	24-18, 18-14 or 24-18, 13-9	4-3	13-9, 13-10 or 24-20, 13-10
6-3	24-18, 18-15 or 24-18, 13-10	4-2	8-4, 6-4
6-2	13-7, 7-5 or 24-18, 13-11	4-1	13-9, 24-23 or 13-9, 6-5
6-1	13-7, 8-7	3-3	—
5-5	—	3-2	13-10, 13-11 or 24-21, 13-11
5-4	13-8, 13-9 or 24-20, 13-8 or 24-20, 20-15	3-1	8-5, 6-5
5-3	13-8, 13-10	2-2	—
5-2	13-8, 13-11	2-1	13-11, 24-23 or 6-5, 13-11
		1-1	—

THE ESSENTIAL SOFTWARE COMPANY

BRINGS YOU

QUALITY PROGRAMS CHOSEN FOR THEIR SUPERB GRAPHICS AND SMOOTH ACTION

APPLE

TRS 80

VIDEO GENIE

ZX 80

**ATTACK
FORCE
WITH
SOUND!**

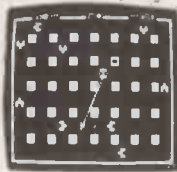

Dodge the alien Ramships and fire missiles to destroy them before they get you. The alien Flagship uses his deadly laser bolt to transform a Ramship into another Flagship or into your ship's double. Look out! Destroy your double and you could destroy yourself.
TRS 80 Level 1 or 11.16K Tape £10
Hours of exciting fun.

**GALAXY
INVASION
WITH
SOUND!**



The newest and most exciting invaders type game yet! Cruel and crafty aliens attack Earth. You are the sole defender. As you fire your laser at the aliens they swoop down and bomb you. Exciting use of graphics! Must be seen.
TRS 80 Level 1 or 11.16K Tape £10
Video Genie 16K Tape £10

NEW

**ASTEROID
NOVA**



For the first time the amazingly popular ASTEROIDS pub game is now available for your microcomputer. Huge asteroids have invaded the galaxy. Your mission is to destroy them and the alien saucers before they destroy you. But beware, big asteroids break up into smaller ones.
TRS 80 Levels 1 and 11.16K Tape £10
Video Genie 16K Tape £10
Apple 11 or 11+ 32K Disk £15

3-D ADVENTURES

FULL SCALE 3-DIMENSIONAL ADVENTURES

Walk down corridors depicted graphically on your screen. Look around to find the objects you need to survive. But beware! Monsters and incredible obstacles can lurk around every corner. Months of fun!

LABYRINTH - TAPE £10

DEATHMAZE - TAPE £10

THE ESSENTIAL SOFTWARE COMPANY (VISCONTI LTD)

47 BRUNSWICK CENTRE, LONDON WC1N 1AF

I have a microcomputer

Please send me your software catalogue. I enclose a stamped, self-addressed envelope.

Please send me

I enclose a cheque/postal order for

£.....
(plus 50p post & packing)

Signature

Name

Address

Postcode.....

PC5/81

SEE OUR COMPLETE
RANGE
AND STAMPED ADDRESS
ENVELOPES FOR FREE
CATALOGUES

NEW
for TRS80
LEVEL II 16K

• Circle No. 169

MX 70 - the super slim printer with a price to match

£260

The 80 column matrix printer with full ASCII international character set, a 5 x 7 text mode plus 8 x 480 bit image for high resolution graphics.

No compromise on speed either - 80 characters per second. Ribbon changing is easy with a cartridge.

It's just as simple to replace the print head (an Epson innovation).

Parallel interface is standard. TRS-80 and Apple II (Plus) optional.

Why so good, yet only £260.

Epson make more print mechanisms than anyone else in the world.
That's why.

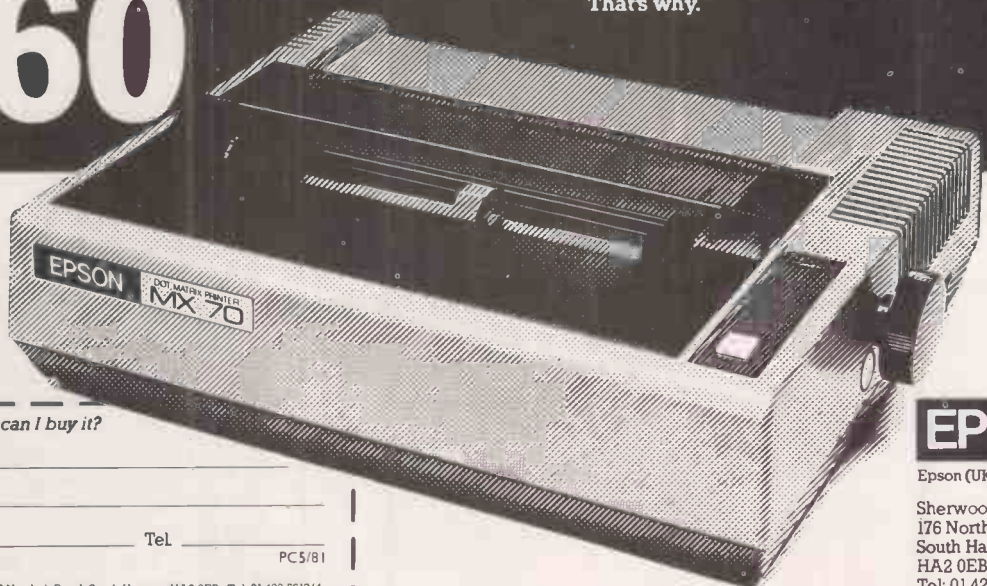

Please tell me more. Where can I buy it?

Name

Address

Tel.

PC5/81

EPSON
Epson (UK) Limited

Sherwood House 176 Northolt Road, South Harrow HA2 0EB Tel: 01 422 5612/4

EPSON

Epson (UK) Limited

Sherwood House
176 Northolt Road
South Harrow
HA2 0EB
Tel: 01 422 5612/4
Telex 8814169

• Circle No. 170

(continued from page 97)

each move considered; the move given the highest value is the one adopted. This value is derived from several other values each of which reflect the assessment of the move and subsequent position according to various strategic factors.

Backgammon is a race and as such may be likened to a middle-distance athletics race in which, during the early stages, the participants engage in tactical manoeuvres before finally sprinting to the finishing line. Yet in athletics, the length of the race is known beforehand — not so the case in backgammon. It is possible at any stage to determine how far off the finishing line is by summing the number of points which must be traversed by each piece. This is

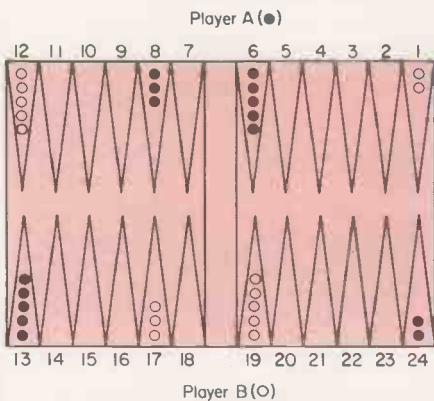

Figure 1. Diagram of a backgammon board with the pieces in the starting positions. called the point count and is 167 at the beginning of the game.

Knowing the point count for the player and the computer, it is possible to determine who is ahead in the race and by how many turns since the average number of points moved in one turn, assuming none is wasted, is $8\frac{1}{6}$ — it is not 7 because doubles require a move through double the normal number of points. If contact between the two sides is still possible, the point count is able to rise because pieces can be hit; if contact is impossible, the point count can only decrease.

It is important to know whether you wish to maintain contact or not as this affects the assessment of whether particular moves are good or bad. Once contact has been lost, the race enters the sprint phase and the players are at the mercy of the dice. If a player is sufficiently far ahead and the distribution of the pieces means that a gammon or backgammon is unlikely, he would be happy to enter this phase.

On the other hand, his opponent would gladly raise his own point count if the alternative was to lose contact and thereby the game. In that situation, he would try to leave blots so that the tactical stage of the race would be prolonged with the possibility that he could then hit back and thus improve his position.

However, he must be careful that his position does not deteriorate to such an extent that a gammon or backgammon becomes a possibility; at some stage it

might be necessary to abandon all hope of winning and instead attempt to lose by as little as possible.

Hitting an opponent's piece increases his point count but also prolongs contact. It is of positive value unless you are anxious to avoid contact or unless you already have a sufficient number of your opponent's pieces on the bar. The further back a piece is sent and the more difficult it is for your opponent to re-enter the better — because inner table points are unavailable.

Leaving blots is only a good move if you wish to be hit or if contact has been lost, when it does not matter. Otherwise, it should be assigned a negative value which takes into account the probability of being hit, how far back the piece would be sent and how difficult it would be to re-enter. On a slow computer, we recommend evaluating the approximate probability only.

Making points is the alternative of leaving blots but becomes of positive significance when the point made is on the active side of an opponent's piece. Not only does it hinder his movement past the point, but it threatens him should he leave a blot without moving past. Clearly, not all points are of equal worth. At the beginning of the game, the most important points for the computer to capture, in probable order of value, are: 20, 5, 21, 7, 4, 22 and 18.

The hindrance value clearly increases as consecutive points are made, up to six. When six consecutive points are made, it is called a prime and an opponent's piece is unable to move past. Note that a seventh point adds nothing.

A builder point is one containing a piece which is in a position to move to a desirable point not already made, using the throw of one die should it be suitable. The piece should also be one the player would not mind moving. In figure 3a, points 10 and 8 are builder points with respect to point 7, whereas in figure 3b, points 11, 10, 9 and 8 are builder points and therefore in this respect figure 3b represents the better distribution.

During the end-play, where you are homing in on your inner table and bearing off, some further considerations regarding the distribution of your pieces are necessary. First, the case where contact has not been lost. If you are in the end-game, you must be ahead and therefore wish to play safely. Thus, you should avoid leaving blots and maintain continuity, two aspects already covered. In addition, to avoid leaving blots on future moves, you should try to keep spare pieces on the points furthest out and an even number on the last two points.

Alternatively, if you are trying to avoid a backgammon, then obviously you move your pieces from your opponent's inner table as quickly as possible. To avoid a gammon, maximise on cross-overs between tables and move your pieces into your own inner table as quickly as poss-

ible, if necessary piling them up on to the 6 point. However, if there is a race to bear off first and all your pieces are piled up on the 5 and 6 points, you will not be in a good position to bear off easily.

Thus, when homing in, you should aim to distribute your pieces evenly within your inner table. It is also undesirable to strip the higher points too early. For example, it is better to have one piece on each point in your inner table than to have three pieces on each of your three and four points even though both distributions have the same point count, i.e., both need a total dice score of 21. This is because if a six is thrown in the second case, two of the dice score is wasted.

At first glance, it may appear that the best policy to adopt is to play safe always; but you are unlikely to win many games if you do. Safe play is fine when you are ahead in the race and do not want to let your opponent back in.

Leaving blots means that you are more likely to be hit, but also that you are more likely to hit your opponent if he leaves blots. Furthermore, provided you can re-enter once hit, you then win the chance of another crack at him.

Having constructed a formula, a useful test to apply is the set of opening moves given in table 1, which are generally agreed by backgammon experts to be the best. Of course, a look-up table can be used for them, but it is more satisfactory to be able to demonstrate that you have

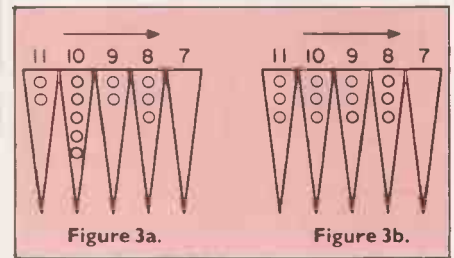

Figure 3. Builder points.

the best formula for the opening stages without recourse to a table.

Further formulae are necessary to decide when to offer a double and whether to accept one if offered. You should offer a double when you have a strong advantage, but not one so great that it might lead to a gammon or backgammon. You should accept a double if you consider that you have a greater than 25 percent chance of winning.

That is difficult to calculate, except when there are few pieces left. The doubling formulae should normally be based on the relative point counts and the length of the game plus an adjustment for the potential of the current position.

References

Hans Berliner, *Computer Backgammon*, Scientific American, June 1980, volume, 242, number 6 for details of the world champion's defeat.
 Paul Magriel, *Backgammon*, Hamlyn, 1976.
 Thomas H Naylor, Joseph L Balintfy, Donald S Burdick, Kong Chu, *Computer Simulation Techniques*, John Wiley & Sons, 1968.

(continued on next page)

EXPLORER-85 COMPLETE BUSINESS SYSTEM AT A FANTASTIC PRICE



**64K COMPUTER — VDU —
TWO 8" DRIVES —
PRINTER — CP/M 2.2 —
EXTENDED MBASIC**

£2900.00

*All you need to run your business
We can supply software to suit your particular requirements*

EXPLORER-85 COMPUTER Kits Start at £85

8085A cpu — S100 Based System Designed for maximum Flexibility

**PROBABLY THE MOST EXPANDABLE KIT ON THE MARKET TODAY.
A COMPUTER FOR YOUR REQUIREMENTS TODAY AND TOMORROW BE IT BEGINNERS KIT:
OEM CONTROLLER: OR FULL DISC DRIVE SYSTEM
EXPLORER-85 NOT THE CHEAPEST, JUST THE BEST**

8085A cpu — S100 slots (expandable to 6) — Powerful 2k Monitor — 4K RAM (expandable to 64K) —
8k Microsoft Basic — Speed 3.1MHz — 4,8bit I/O Ports — 1,6bit, I/O Port — 14bit Binary counter — All
programmable — Stand alone Keyboard Terminal — 64/32 characters 16 lines — upper & lower case —
Full cursor control — Power supply unit — **NO EXTRAS NEEDED**

4K system complet kit £327: Assembled Uncased £402: Assembled & Cased £502

16K system complet kit £410: Assembled Uncased £485: Assembled & Cased £585

Limited Budget? You can purchase explorer 85 in sub kits starting from £85 for the Motherboard Level 'A'.

EXPAND YOUR SYSTEM WITH 8" DRIVES

8" Control Data Corp Professional Drive
* LSI Controller * Write protect * Single or Double
density * Capacity 400K Bytes (SD) 800K Bytes
(DD) unformatted * Access time 25ns. **Price £350**
DISC CONTROLLER I/O 5100 CARD
Controls up to 4 Drives * 1771 ALSI (SD) floppy disc
controller * On board data separator (IBM com-
patible) * 2716 PROM socket included for use in
custom applications * On board crystal controlled *
On board I/O baud rate * Two serial I/O ports *
Autoboot to disc system when system reset *
Generators to 9600 baud * Double sided PC board
(glass epoxy). **Price £150**
DISC DRIVE CABINET WITH POWER SUPPLY
De Luxe steel cabinet to house single drive with
power supply unit to ensure maximum reliability and
stability. **Price £79**
**DRIVE CABLE SET UP FOR TWO
DRIVES** **Price £19**

64K 'SJ64K' S100 DYNAMIC RAM CARD

We offer you ... Hidden refresh ... fast performance
... lower power consumption ... latched data out-
puts ... 200ns 4116 RAM's ... on board crystal ... 8K
bank selectable ... fully socketed ... solder mask on
both side of the board. Designed for 8080, 8085 and
Z80 bus signals ... works in Explorer/85, Tuscan,
Horizon Sol, as well as all other well-designed S100
computers.

Kit	W/T	Kit	W/T		
16K	£149	£169	48K	£239	£259
32K	£194	£214	64K	£284	£304
				16K upgrade kits	
				£45	

SOFTWARE

CP/M 1.4 £75 — CP/M 2.2 £98.00
Microsoft extended MBasic £155

Now-Break Through The 64K Micro-Memory Limit! 'SS16K'

Bank Selectable 16K Static RAM
Don't buy any more antique RAMs (RAM without bank select) — now there's
Netronic's new SS16K board featuring a universal software bank select system.
SS16K is capable of addressing 2,048 different banks. With SS16K boards you can
add memory beyond the 64K limit, or expand to a multi-terminal system.

LOOK AT THESE FEATURES:

- 300 NS, low power 2114's.
- Software Bank Selector — Universal decoder works with Cromemco, Alpha Micro, Netronics, most other systems, or your design. Onboard dip switches: Bank Select Enable; Reset Enable; Reset Disable; Port Address; Port Data.
- All Inputs And Outputs meet the proposed IEEE standards for the S-100 bus.
- 4.0 MHz Operation
- Schmitt Trigger Buffer on all signals for maximum noise immunity.
- Addressable On 16k Boundaries, 0-64k, dip switch selectable.
- Phantom Option, dip switch selectable.
- PWR/MWRITE Option, dip switch selectable.
- LED Indicator to display status.
- Glass Epoxy PC Board with gold-plated contacts and double-sided solder mask.
- Fully Socketed. • Four Separate Regulators for maximum stability.
- £149 Kit: Assembled & Tested £175.

THE ELF11 IF YOU REALLY WANT TO UNDERSTAND COMPUTERS THEN ELF11 for YOU



Basic Specification
RCA COSMAC 1802 cpu — ¼K RAM expand-
able to 64K — DAM — Interrupt — 16 registers
— Fully Decoded Hex Keypad — Dual 7 segment
display — Crystal clock — Onboard regulation —
1861 Graphic Chip — 5 slot expansion bus —
Double sided plated through PC Board.

ELF11 is Ideal for Beginners — Engineers —
Industry — Scientific and Educational purposes

SPECIAL OFFER £49.95

You will LEARN to program in Machine code and really
understand computers, from there you can expand it to meet
your requirements upto 64K RAM working in Basic level 111
**Suggested Starters Pack: — ELF11 kit + RF Modulator +
T. Pitmans Short Course for £56.70**

**ELF11 EXPANSION. We carry a full range of expansion
kits — HARDWARE — FIRMWARE — SOFTWARE —
MANUALS. Send S.A.E. for brochures.**

**NOW AVAILABLE — FULL BASIC LEVEL 111 + RPN Maths
package COMING VERY SHORTLY — EPROM BURNER**

10" MONITOR £79.95

IDEAL FOR APPLE NASCOM
U.K. 101, ETC.

Designed for monitoring computers,
closed circuit, TV and Video
Tape Recorders
10" black and white video monitor
10 MHz band width
High quality metallic cabinet.
• Dimensions: 9" x 9" x 9 1/2"
Trade Enquiries Welcome

Oki Microline 80

SMALL, LIGHT QUIET MATRIX PRINTER

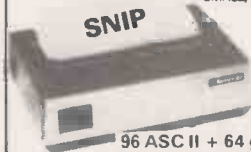

UNBEATABLE
VALUE AT
£299

40, 80 or 132 cols.
6 or 8 lines per Inch.
96 ASC II + 64 graphics character set
with Centronics compatible interface
(Serial Interface £75 extra)

Centronics 737

LETTER QUALITY PRINTER

AT ONLY £399



• Dot Matrix: 7 x 9 • Paper
Handling: 3 way • Pitch: 5, 10 or 16
characters per inch • Speed: 80
characters per second proportional/
50 characters per second
monospaced • Line Length: 40, 80
or 132 characters • Standard Inter-
face: Parallel
(Serial version £429)

SEND SAE FOR COMPREHENSIVE BROCHURE

Please add VAT to all prices. P&P extra. Please make cheques and postal orders payable to
NEWTRONICS or phone your order quoting BARCLAYCARD, ACCESS number.

We are open for demonstrations and Sales. Monday-Saturday 9.30 a.m.-6.30 p.m. Near
Highgate Underground on main A1 into London.

Newtronics



255 ARCHWAY ROAD,
LONDON, N.6 TEL: 01-348 3325



• Circle No. 171

Duncan, a high-level interpreter for Nascom 1, can run three to four times faster than an integer Tiny Basic and just begs to be used for real-time control applications.
John Dawson reports.

PEOPLE making initial contact with computers should be aware that computer languages take many forms. They can be designed for special or general purposes and are nothing more than a way of grouping fundamental machine-code instructions into statements and commands which can be used more easily by someone wishing to program a computer. For example, a language called Unkle has been introduced for possible use by British Telecom staff working with System X, while Mumps was developed by DEC specifically for medical information systems.

Common high-level languages are not well suited to microprocessor-control purposes as each has an emphasis towards the environment of the original user. Commercial languages are distinguished by their ability to handle files, perform decimal arithmetic and manipulate textual information. Scientific languages are usually able to handle floating-point numerical calculations and arrays of data.

High-level languages do not produce very efficient machine-language programs — most versions of interpreted Basic, for example, will execute only a few 100 instructions each second. Conversely, a high-level language may produce a program listing which conveniently describes the tasks the language will undertake. Far less time may be needed to write a program in a high-level language than in an assembler or machine-code-based system.

Command and control

Command and control languages have been developed for real-time processing on large computers — there is a language called Ironman or ADA which has been developed from a Pascal base for the U.S. Department of Defence and Coral 66 is claimed to be a real-time, high-level compiler. Coral is not readily available on microprocessors but has a number of extensions allowing bit manipulation and the control of unusual peripheral devices. It has, however, no mechanism for dealing with interrupts and it is a hallmark of real-time languages that they can

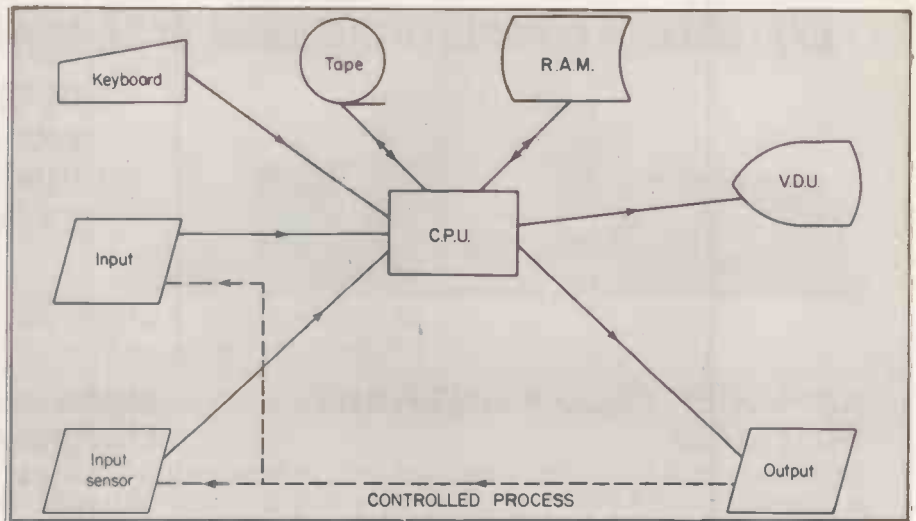

Figure 1.

Duncan brings a new economical simplicity to Nascom 1 programs

respond to the asynchronous and unpredictable flow of information in the real world.

Many microcomputer applications involve the reception of data and other information from input devices and sending data and control information to output devices — figure 1. The circular path from the input sensor to the CPU, to the output device and through the controlled process back to the input is an ordinary closed loop feedback system in which the computer, CPU, may switch the process on or off, or modify it according to the data from the sensor. The CPU may scale the input and may, for example, output a linear control signal on the basis of a logarithmic input, or inject or remove hysteresis from the system.

Robotics aspects

Articles on shaft encoders and other aspects of robotics have been published in *Practical Computing*. Often the control and status information used in control systems is made up of a few binary digits with very precise hardware-related meanings. In these conditions, a machine-code program is attractive for its speed and ability to compare and manipulate individual bits in a byte of data.

We live mostly in a world of eight-bit accuracy. For many purposes, an incremental scale of 255 parts is entirely sufficient to describe the range of our experiences. We seldom need to know the temperature of our environment to better than one degree Centigrade — 40 degrees C to +40 degrees C is 80 increments — or the time for which an egg has boiled to less than five seconds — one part in 48 over a four-minute period.

Wind direction may be measured to two degrees using 180 increments by meteorologists and its speed to half a mile per hour, 250 increments. In amateur scientific applications, eight bits can produce a resolution of better than 1/20in. in 10in. on a graph plotter, and will locate a robot to within plus or minus 1in. of its target in a roof 20ft. square.

Duncan is a high-level interpreter for the Nascom 1 computer written in machine code and operating under the T4 monitor. It contains instructions for the acquisition, logging and processing of data in addition to the usual arithmetic and logical operators. Unlike Basic, Duncan has no line numbers and should be treated as a stream of source instructions to the computer in which labels act as points of reference for jumps and sub-routine calls.

Duncan runs three or four times faster than an integer Tiny Basic. The language is aimed at the control of external devices and has many uses in schools, electronic service workshops, model control systems, and the home.

Structural analysis

A flowchart illustrating the structure of Duncan is set out in figure 2. The program executes at 0EF0; the program name is displayed and the entry table and a prompt are displayed on the next line. The eight command modes are set out in table 1 and they allow the creation of a new program, its subsequent printing, editing and execution, its storage and retrieval on cassette, and the storage and retrieval of data acquired during a program run.

The language occupies RAM from 0C50 - 1400 — 1968 bytes decimal —

which includes an area for the storage of variable values from 13C0 - 1400. Scratch-pad RAM is located at 13A0 - 13BF. Instructions are stored from 1400 - 15FF and the area 1600 - 17FF is used for logging data. The program area is 512 bytes in size and will overlay the data log area if further instructions are entered. The existing memory allocation is, however, generous for the majority of applications.

The data log may be re-located on large systems and can be adjusted to store values to fill whatever RAM is installed. Details of a memory expansion board for the Nascom were published in *Practical Computing*, November 1980.

Indispensable aid

Hard copy is an indispensable aid to most computer applications and Duncan includes subroutines to format and print data on a teleprinter accepting CCITT five-element code. The instruction set has been designed for its mnemonic appeal within the limitations imposed by the character set available on Creed teleprinters.

Both the instruction mnemonics and their correlation with the equivalent printed character can be altered easily. The hardware and software for a Nascom/Creed interface were described in *Practical Computing*, July 1980.

Duncan works with 16-bit unsigned integers, 0 - 65535, and has I/O facilities for eight-bit data values. The sign of the result of a calculation is unimportant for control tasks as a D-A converter can be set up to output 0 volts with an input value of 128, swinging to the maximum positive and negative outputs at 511 and 0 values at the input respectively.

Circuit diagrams

The Ferranti ZN 425 E-8 data sheet contains practical circuit diagrams for both D-A and A-D converters. This chip can be connected easily to a PI/O port on an unmodified Nascom 1.

Duncan allows conditional jumps to be made and subroutines may be called although nested subroutines are not allowed. Duncan uses reverse Polish notation in which numbers are pushed up a stack and are brought down in the course of a calculation. The language uses number handling routines derived from M5, which was described by Raymond Anderson in the *Liverpool Software Gazette*, November 1979.

The theoretical program illustrates the simplicity and economy of a Duncan control sequence. The program should be read with the explanation of each step and in conjunction with the full instruction set which is listed in table 2. The program will turn off a dark room safelight, make an exposure in an enlarger after recovering the time in seconds from a keyboard entry, and then turn on the safelight.

The program assumes that D-A converters are connected to the Nascom

PI/O and that the converters are used to switch relays for control of the lights. The safelight is connected to port 4 and the enlarger to port 5:

```
0 = x 255 = z LA
z S4 ? = t
x S4 z S5 t W x S5
JUA:
```

The following steps occur when the program is executed:

- 0 = x The CV, which is explained in detail later, is set to 0 and this value is stored in variable x.
- 255 = z The CV is set to 255 and this value is stored in variable z.
- LA Label A — this is a reference point in the program.
- z S4 The CV takes the value stored in variable z (00255) and this value is set at port 4. The analogue voltage at port 4 will go high.
- ? = t The program looks for a number from the keyboard. The language handles 16-bit unsigned integers, 0 - 65535. The last five numbers entered are used, leading zeros are not required and the operation is terminated by any non-numeric character, e.g., 773 new

line is acceptable. The screen is scrolled-up one line and the cursor set to the bottom left-hand margin.

- x S4
- z S5 The CV is set to the value stored in variable x, 00000, and this value is set at port 4. A similar process takes place at port 5, 00255. The safelight has been turned-off and the enlarger turned-on.
- t W The CV is set to the value obtained from the keyboard and previously stored in variable t. W is a programmable wait instruction and the computer waits for the length of time determined by t. 1W produces a wait of one second.
- x S5 The enlarger is turned-off after the computer has emerged from the wait state.
- JUA The program jumps unconditionally to label A and the safelight is turned on before a new number is requested from the keyboard.
- : Marks the end of the program.

This program is very simple, it does not set up the PI/O ports as outputs, for example, and could be made much more convenient. There should be no need for a new exposure time to be entered before

(continued on page 105)

Figure 2.

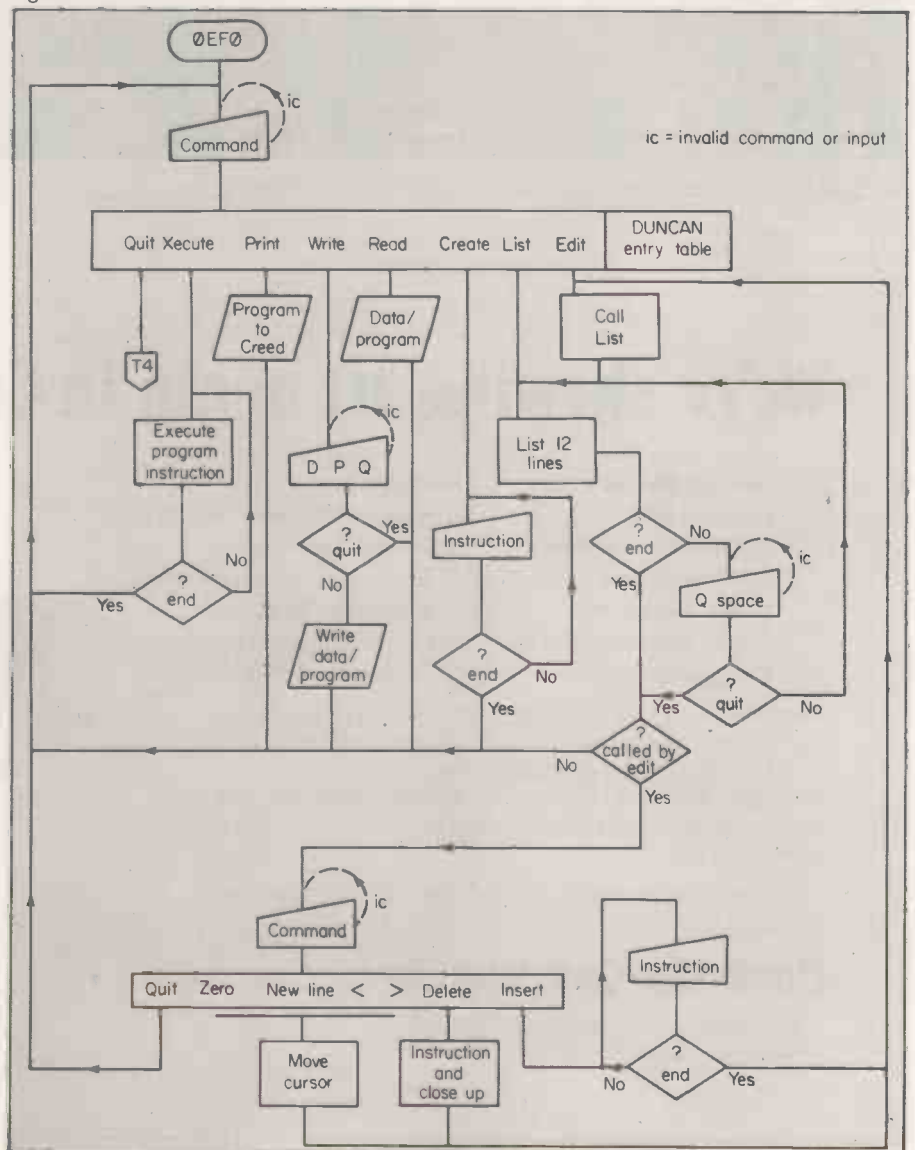



Digital Design and Development
18/19 Warren Street London W1P 5DB Tel 01 387 7388

Scientific and Industrial Interface Specialists.

SHARP MZ-80K CBM PET

Specialist Suppliers of Complete Systems for Industrial and Laboratory Monitoring and Control.

SHARP MZ-80K INTERFACES

- Parallel Printer Interface £110
- Serial Printer Interface £150
- Bi-Directional Serial Interface £210
- 16-Channel A/D Converter Unit £280
- Fast Data Acquisition System – 40,000 readings/sec. 4 analog channels channels IN and 4 channels OUT. £1200

PET INTERFACES

IEEE-488 Compatible Units

- 16 Channel 8-Bit A/D Converter £300
- 8 Channel 8-Bit D/A Converter £350
- 8 Channel 12-Bit A/D Converter £600
- 12-Bit D/A Converter £695
- X-Y Analog Plotter Interface £200
- Digital Data Input Unit, 64 Bits £400
- Digital Data Output Unit, 64 Bits £350
- 16 Channel Relay Unit £350

Also . . .

- USER Port Converter A/D plus D/A £200
- Fast Data Acquisition System 40,000 readings per sec. 4 A/D + 4 D/A £1200

All units boxed complete with IEEE-488 address internally selectable, with integral power supply, cables, switch, fuse, indicators and illustrative BASIC software.

TERMS: All prices Ex-VAT. P&P extra. Cheques should be made payable to 3D Digital Design & Development. All goods supplied under 90 days warranty. **CUSTOM DESIGN UNDERTAKEN.**

• Circle No. 172

We're showing off again in Cambridge!

- TRS-80 Model I & II
- Apple II & III
- North-Star Horizon Communicator
- Commodore Pet
- Daisy-wheel printers
- Computer books

- Acorn Atom
- Hewlett-Packard HP85
- UK101 kit computer
- Sharp pocket computer
- Wordstar/Datatar
- Plotters/digitisers
- Electronic components

First time buyer or experienced user? See what's best in microcomputers today — a comprehensive selection from £100 to £10,000, all generally on demonstration and available from stock. Take this opportunity to choose your ideal system, with the active help of our team of computer professionals.

Interested in microcomputers? — then we've got the Show for you at:

Cambridge Computer Store

1 Emmanuel Street Cambridge CB1 1NE
Telephone: (0223) 65334/5

Mon.—Fri: 9.00 to 12.30, 1.15 to 5.30. Sat: 9.00 to 5.30

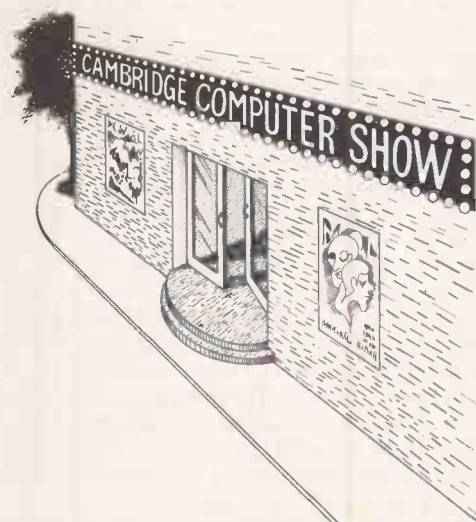

• Circle No. 173

(continued from page 103)

each print is made and the program could be modified to ask if a different time is necessary. It demonstrates a control system with a practical function and which uses only 32 bytes of program storage discounting spaces which can be removed from a practical version.

The current value, CV, is held in the register pair DE in the Z-80 CPU. The CV may be displayed at any time in the course of a program by the instruction =?. The CV is altered in the following circumstances:

- When a number is encountered in the course of a program the CV is replaced by the number.
- When a variable is encountered the CV is replaced by the value stored in the variable.
- The instructions I and D increment and decrement the CV respectively.
- After an arithmetic operation, the CV contains the result. When a ? instruction is encountered the program obtains a numeric value from the keyboard and the CV is replaced by the new number.

The stack is lifted by the comma instruction ',' and the CV is pushed up the stack — a second comma will lift the stack again pushing stack 1 to stack 2 and the CV to stack 1. The CV is unaltered by the lift instruction. The program sequence:

```
45,,++=?
```

will perform the following operations:

CV	Stack 1	Stack 2	
xx	xx	xx	45
45	xx	xx	,
45	45	xx	,
45	45	45	+
90	45	xx	+
135	xx	xx	=?
Screen displays			00135

Similarly, the program sequence:

```
6=V,?*=?
```

will set the CV equal to 6, store the CV (6) in variable V, lift the stack, obtain a number from the keyboard and place it in the CV, multiply stack 1 by the CV, place the result in the CV, and output the result to the screen. The stack operations are shown below:

CV	Stack 1	Stack 2	
6	xx	xx	6
6	xx	xx	=V
6	6	xx	,
Input (7)	6	xx	?
42	xx	xx	*
Screen displays			=? 00042

Variables may be identified by any lower-case alpha character. Hence, Duncan allows 26 variables and there is a special remainder variable — upper-case R — which stores the overflow or under-

- Ax Acquire data from port x and place the value, 0 - 255, into the next sequential location in the data log. CV is maintained intact.
- B Bring back the value in the data log pointed to by the CV when the B instruction is entered. The CV is destroyed and replaced by the data value, 0 - 255.
- Cx Clear the data log area, CD, or clear the screen. CS. Each location in the data log, CD, is set to zero and the log pointer is set to the start address — 1600 Hex.
- D Decrement the CV by 1.
- I Increment the CV by 1.
- Fx Find the value, 0 - 255, at port x and place in the CV.
- Sx Set the value in the CV, 0 - 255, at port x.
- Jcl Jump if condition c is satisfied to label l:

- C - U Unconditional
- Z CV = 0
- N CV not = 0
- E CV = stack 1
- X CV not = stack 1
- L CV less than or equal to stack 1
- G CV greater than stack 1
- S Jump to start of program
- B Jump to Breakpoint and display Z-80 registers.

KH KH causes the program to scan the keyboard and jumps to Hold if any key is pressed.
 KSI KSI causes the keyboard to be scanned and if a key is pressed the program will call at the subroutine identified by label l. KA does not scan the keyboard but causes the low byte of CV — values up to 255 are entered correctly, larger numbers are entered modulo 255 — to be placed into the data log at the next sequential location.

Lx Label followed by identifier x to which jumps and subroutine calls may be made.
 H Hold program execution. Continue execution by pressing space bar. Press Q to quit program and return to the entry table.

W Programmable wait instruction. The program halts for a time defined by the value in the CV when the instruction is entered. One wait instruction, 1W, lasts approximately one second.

Pc Prints the character immediately following the instruction. Special functions are executed by four suffixes:

- S Prints the top 15 lines of the Nascom screen.
- L Prints the bottom line of the screen.
- / Prints carriage, return and line feed characters.
- / Prints a line feed character.

(t) Text t between brackets is displayed on the Nascom screen starting at the current cursor position.

Full stop — scrolls the Nascom screen up one line and places the cursor at the bottom left-hand margin.

Comma — lifts each value in the stack and places the CV into stack 1. The CV is maintained intact.

\$l Program execution is transferred to the subroutine at label l. The CV is maintained intact into the subroutine. There is no provision for nesting SRs.

; Return from subroutine. The CV is maintained intact.

? Obtains a number from the keyboard. Entry is terminated by any non-numeric character. The largest number that can be handled by Duncan is 2¹⁶ or 65535 decimal. The value entered becomes the CV.

=? Display the CV on the Nascom screen starting at the current cursor position. The CV is maintained intact.

=v Replaces whatever value was stored in the variable v with the CV. CV is unaffected by the instruction.

+ Arithmetic operator — adds the CV to stack 1 — the value at the top of the stack — and places the result in the CV. Overflow bits from the operation are lost.

- Arithmetic operator — subtracts the CV from stack 1 and places the result in the CV. Underflow is not detected.

* Arithmetic operator — multiplies the CV by stack 1 and places the result in the CV. Overflowing bits are placed in variable R.

/ Arithmetic operator — divides stack 1 by the CV and places the result in the CV. Underflowing bits are placed in the variable R.

: Colon — program terminator. Places three ASCII zero bytes in the program store and returns from the Create mode to the entry table. This character may appear only at the end of a program and is forbidden inside bracketed text.

Table 2. Duncan instruction set.

flow bits after multiplication or division. Overflowing bits in addition and subtraction operations are lost. The following program illustrates how the R variable works:

```
? , ? / =? ( ) R =? :
9 3 Screen displays 00002 00001
15 4 00003 00003
141 12 00011 00009
```

Leading zeros are displayed. The brackets define text which is to be output to the screen. In this case, the space between the numbers and the R variable contain the remainder of the division modulo, the divisor.

The port identifier following the find, set and acquire instructions may be any numeric character or upper-/lower-case alpha character. This allows the system to address 62 ports where port 0 = identifier 0. Ports 6 and 7 address the PI/O control ports and ports 4 and 5 are the I/O addresses. In extended systems port E, for example, addresses port 21 decimal, 15 Hex.

Error messages are displayed for faults in program construction. Jump commands for which no label can be found will generate the message, JUMP

(continued on next page)

(continued from previous page)

ERROR, following which the program enters the edit mode, listing the program on the screen with the cursor pointing to the incorrect jump label. The acquire command sets the PI/O ports to input data and generates an error message if an attempt is made to address the control ports.

Programs running under Duncan may be synchronised to external events by using the principle of deliberate error. The synchronisation may either be to an external time signal or to some other event. The control program is set to finish its task deliberately ahead of the time at which a reference signal is expected.

The program then enters a loop in which the value obtained from a port is compared to a value set in a program. When the reference signal occurs, the value obtained by the port is greater than the comparison value and the program jumps to the next phase.

Subroutine group

A standard Nascom 1 has no interrupt facility, but Duncan can poll a number of devices to see whether or not an event has occurred which requires some action. After obtaining a value from a port, the program can be diverted to one or another of a group of subroutines depending on the incoming reading. Although the subroutine may be called from several points in a program, it is not necessary for the subroutine to return to the instruction following the call.

Because the program does not allow subroutines to be nested, no problems are created when a jump is made from a subroutine back into a different section of the main program. The return address for the subroutine call is still available and will be

Table 1. Duncan entry table.

P	Prints the current Duncan program and returns to the entry table.
W	Prompts for data, program or quit. Writes the data log area or the program to cassette and returns to the entry table. Quit returns directly to the entry table.
R	Reads either data or a program into the correct area for subsequent processing. Returns to the entry table.
Q	Quits the entry table to the Nasbug T4 monitor.
L	Lists the current program. If the program occupies more than 12 lines, the second page is displayed by pressing the space bar. Q will quit the list mode either to the entry table or, when list is called by the edit mode, back to the edit mode.
C	A new program is created and overwrites any instructions previously stored. The keyboard functions normally with the exception of the : (colon) which terminates the create mode and returns to the entry table.
X	Causes the stored program to be interpreted by Duncan and executed.
E	Edit mode. The stored program is listed automatically by the list mode and the edit functions set out in table 3 may be carried out. Q causes the termination of the Edit mode and a return to the entry table.

- < Moves the cursor one position to the left on the screen and one instruction towards the beginning of the program. The shift key should not be pressed as the < function is interpreted directly by Duncan.
- > Moves the cursor one position to the right on the screen and one instruction towards the end of the program. The shift key should not be pressed.
- Z Zeros the cursor to the first instruction in the stored program. The character at the position occupied by the cursor is displayed on the right-hand side of the top line of the screen.
- N Searches for the next new-line character and positions the cursor at this point in the program. If the end of the program occurs first, the cursor is placed on the terminating instruction.
- D Deletes the instruction at the cursor position and closes up the remainder of the program.
- I Instructions may be inserted into a program by typing I followed by the new instructions. The keyboard may be used to enter any character except a ':' which terminates the function and adds the instructions to the program.
- Q Quits the edit mode for the entry table.

Note: It is possible to move the cursor from the program area and into the variable-storage RAM. Beware of inserting or deleting characters if the cursor is not visible on the screen. The Z command will always return the cursor to the top-left position of a listed program at the first instruction.

Table 3. Duncan edit mode functions.

destroyed and replaced when a new call is made.

Hysteresis can be programmed into a switching operation so that a process is effected when the value obtained from an A-D converter exceeds one value, for example 200 on a scale of 255 increments. A second section of the program may then switch the device off or effect some other process when the value monitored by the A-D converter falls below 100 on the same scale.

Accurate meter

The Nascom 1 used with Duncan and a simple Creed teleprinter can act as an accurate digital printing volt meter using the hold and find instructions to measure a voltage when the space bar on the keyboard is pressed. A simple program can be written to find a value which may be scaled and processed by Duncan according to the volt meter scale in use and will then print either the value or an explanatory message followed by the voltage that has been measured. A more sophisticated alternative is to use Duncan to prompt for each test point in a test routine, print the expected voltage or other value and then print the value obtained during the test.

The wait instruction has many uses. One wait state lasts approximately one second and a program may be set to acquire data or carry out some other process at any speed between filling the Data Log, 512 values, in less than a second to the acquisition of one reading each day. If the CV is 65535 when the wait instruction is entered, the computer will do nothing

for 18.2 hours before emerging to continue the program. 12 hours is 43200 seconds and the program sequence for a 24-hour wait is 43200 W W.

The acquire instruction stores incoming information in sequential order ready for subsequent retrieval by the bring-back instruction. Data can be acquired from one or a number of ports and can be interspersed with information such as time markers or values from calculations by using the KA instruction.

Program sequence

Putting the Ax instruction inside a program loop can log data at regular intervals while the addition of a hold or KH instruction to the loop will allow data to be gathered under the control of the user. The program sequence:

```
I=f LA ? KA fI=f,400 JGA
will put 399 values into the data log from the keyboard which can then be used as a look-up table for anything from playing a tune through to displays of normal and abnormal electro-cardiogram recordings for training nurses and intensive therapy unit staff. Information can be retrieved from the data log either sequentially or on a random-access basis using the bring-back instruction.
```

Using a minimum system with a D-A converter on one of the PI/O ports and an A-D converter on the other port, the Nascom/Duncan combination can be used to measure easily a variety of parameters in physical or electronic systems such as the signal characteristics of transistors or operational amplifiers, the efficiency of small electric motors, or an echo location display; either printing or plotting the results on a teleprinter.

Conclusions

- Duncan shows how a high-level language can be developed for a particular purpose.
- The structure of the language is different from Basic but is appropriate for the control tasks for which it has been designed.
- Duncan is easy and satisfying to use with even a minimum I/O capability on the Nascom.
- Above all, Duncan provides an entry into the intoxicating world of real-time control of robots, laboratory experiments, electronic equipment and a diversity of domestic devices from model trains to intelligent vacuum cleaners using a very small computer.

The listing for Duncan is too large to publish. However, a cassette with the program record in T4 dump or write format and back-up documentation may be obtained from John Dawson care of Practical Computing. The package contains the cassette, a printout of a Hex dump and an annotated, disassembled listing of Duncan with additional notes on program reference points to help users who wish to modify the program for their own purposes. The package costs £7.50 inclusive of postage and packing.

Raymond Anderson maintains that you should not develop too heavy a dependence on Pascal because it will repay you by letting you down just when you need most programming support from it. Here are what he considers to be its cardinal deficiencies.

Prolonged use of Pascal can seriously damage mental health

PEOPLE learning Pascal after using Basic for some time soon realise the advantages a structured language can give them, become proud of their mastery of Pascal and seem keen to castigate those who still use Basic. Unfortunately, Pascal is far from ideal, and by the time people realise it, they have to plod on as best they can to ensure their investment in old software is not lost — just as Fortran users have done for 20 years.

My view is that it is better to learn a language which allows expansion within itself as much as possible, so old investment is not lost by providing more facilities, and portability is ensured. Algol 68 is my personal choice, although ADA seems to have achieved this, and in their own ways so have APL, Lisp and Fort.

Some software houses push Pascal because the compiler is reasonably easy to write and easy to sell to somebody unfamiliar with the language. Pascal programmers push Pascal so more users will put pressure on software houses to sell better compilers, and compilers for more machines. Some teachers push Pascal because it is easy to teach, and their pupils will prefer a trendy language.

Burnt fingers

Algol 68 programmers worry that many people will get their fingers burnt on Pascal and lose faith in their climb up the Algol tree. Pascal has some rather interesting features, such as subranges, sets and packed records which I feel are good points, and many features which are common nowadays, and very useful such as records, recursion, data types and so on. Pascal is useful as a first step towards structured programming, but you must not wait too long on the first step or you will grow too weak to climb further.

Programmers in an applications environment find it useful if they can use a set of general-purpose routines provided by experts in some field. Examples of such sets are the Gino and Ginograf graphics routines and the NAG subroutine library for Fortran and Algol 68. There are also many cases where facilities are embedded in languages to make certain activities

easier — for example handling databases or laboratory equipment.

Unfortunately, such useful facilities are very difficult to provide in Pascal. This is because a procedure which takes in an array as a parameter can only take arrays of size fixed in the procedure declaration. A procedure written for integer arrays of 100 elements could not be used with arrays of 101, 99 or 3 elements,

Even Fortran provides better facilities for making libraries available — indeed, this is one of its main strengths in engineering and scientific fields. Algol 68 allows new operator definitions for any data types. APL users in business often use a set of functions provided by programmers so they do not need to concern themselves with detail. This serious fault in Pascal was caused by an obsessive desire to simplify storage allocation, but the disadvantages are far too severe to justify the simplification.

When a program has been written and the algorithms checked using test data, it often has to be used by untrained users and on real data. Users will often feed in corrupt data — letters instead of numbers, blank lines, overlarge numbers or just gibberish, and a good program will give some indication of the error and try to continue to find more errors, rather than just bombing out.

Writing a robust program just to read a number from a file is very difficult in Pascal, because so many faults can occur which the program cannot sort out by using the inbuilt routines to read an integer. Consider some of the possible errors:

- The file is empty
- The file is a line of blanks
- There are blank lines before the number
- The file starts with the letter X
- There are superfluous characters after the number
- The number is too large or small to hold an integer variable

The Pascal programmer has to forget the system routines, and write his own new ones to read character by character. More room for error and more work. Algol 68, Cobol, and PL/1 allow check-

ing on input, and Fortran 77 has a method of trapping errors.

Pascal has no facilities for opening and creating new files, and cannot enquire about the status of files to which it is connected except for detecting end of line, EOLN, and end of file, EOF. It is, in fact, so inadequate at file handling that almost all implementations have their own non-standard extensions, thereby reducing portability.

When Pascal was designed, it was decided that several restrictions would be made to simplify compilation, and increase efficiency on the processors of the early 1970s. One of these restrictions is that the bounds of arrays had to be constants available at compile time.

Wasted space

That means that a program or routine cannot declare the workspace it needs at a particular time. Instead, it has to declare an array which is as large as it should ever need every time, thus wasting space on most occasions. On microprocessors with a limited address space, a waste of space is worse than a slight reduction in speed.

Pascal requires that declarations of all procedures, variables, and so on, are made at the top of the main program body, and at the top of each procedure body. This is another example of how a restriction meant to make life slightly easier for the compiler writer is a problem for the programmer, especially when he is working on large programs. Once again, the result is a waste of space.

Suppose one block in the program uses some integers, and another uses some reals, and these variables are confined to their respective blocks. If the variables could be declared in their respective blocks, there would be re-use of store — saving space — no access to the variables outside their block — preventing errors — and the type of the variables is clear near where they are used. There is no run-time penalty, and hardly any increase in compiler complexity.

Procedures could be used in place of the blocks, but this can lead to a proliferation

(continued on next page)

(continued from previous page)

of small, 25-line procedures, and marked loss of speed.

The Pascal For/Do loop is very restricted and often has to be replaced by some open-coded equivalent using a While construct. There is no Step or By part, so the loop variable can go only up or down in steps of one. This petty restriction, supposedly for efficiency, is another area where Pascal hinders straightforward coding and obscures intentions — the loops may as well always start from 1.

A While part cannot be combined with the Do loop, so an exit from the loop on some condition — for example, the end of a search — has to be by a Goto to some label outside.

The final oddity is that the loop variable has to be declared in the normal manner at the top of the program or procedure. Apart from slowing down coding, it has the undesirable effect of making the variable accessible to code in the loop or in procedures declared "below it in scope" where it can be accidentally altered, causing chaos.

A useful feature of Pascal is its Case construction which allows the selection of one of several courses of action depending on the value of a variable, or which member of a set it is. Unfortunately, this feature is marred by the lack of a Default or Out part which is a way of specifying what to do if there is no relevant Case action.

Most Pascal implementations do nothing if the selector is not catered for, but one usually wants to take some action if an exception arises, and one has to use an If construction of some kind. This is yet another serious flaw in Pascal, which, this time, has no excuse.

Pascal does not provide access to the individual bits in integers to allow packing of data, logical operations or shifts — often very important for systems programming.

Insecure areas

Pascal is a rather more secure language than, say, Fortran, which means that not so many expensive runtime checks would be required behind the scenes to prevent accidental or deliberate but dangerous tampering with data.

Unfortunately, Pascal becomes insecure in the areas which many programmers are already having difficulty thinking about what should be happening if all goes well; the areas of variant, pointers, and heap storage.

Firstly, the mark and release scheme of storage management is completely unchecked, and allows easy corruption of store. Admittedly, a garbage collector is a complex beast, but it saves the programmer a good deal of work in storage management, one of the major parts of many problems.

Secondly, a variant record can be established with one type, and then

assignments can be made to the fields of the record pretending it is some other type, possibly one which occupies more store, thereby corrupting neighbouring data.

Thirdly, since a procedure parameter does not have a "type" associated with it, checking of the number of arguments used by the procedure when it is called inside another procedure are highly difficult — perhaps impossible — at compile time, and usually never made at compile time. It is a similar problem to that encountered in Fortran where it is impossible to tell at compile time if subprograms are being called with the correct number and type of arguments.

Pascal has deficiencies in many areas, ranging from annoying omissions — Step in Do-loop, Out in Case construct — to serious design flaws — fixed size of array parameters.

Those deficiencies do not mean that the language is unusable, but they mean that difficulties arise just when the compiler and language should be helping most.

The insecurities mentioned in the final section mean that as things grow harder and harder to monitor, data corruptions can occur causing faults in unexpected places, and storage becomes more difficult to manage.

By all means use Pascal if you need a structured language quickly, but keep looking for a longer-lasting tool and invest in it as soon as you can.



PET GRAPHICS SOFTWARE



FOR 16K OR 32K PET EQUIPPED WITH PET TRACTOR FEED PRINTER ONLY

(No disk drive and No plotter required)

COMPUTACE Ltd. INFABCO HOUSE, 552/556 LONDON ROAD, NORTH CHEAM, SUTTON, SURREY



SOFTWARE UNDER DEVELOPMENT PERSPECTIVE AND ISOMETRIC DRAWING WITH MASKING AND SHADING

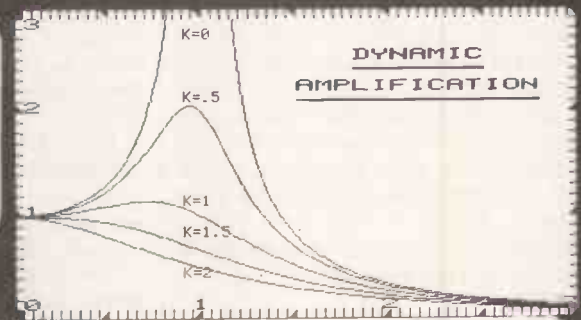
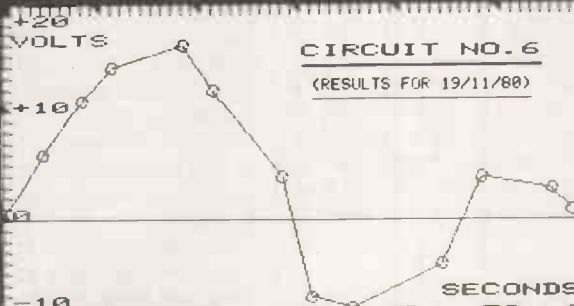

Professional Quality, single Pixel accuracy graphs are printed on the standard Pet Tractor Feed Printer by the AUTOGRAPH programme: Simple to use, all Basic software Fully flexible graph dimensions and position on page Automatic Scale Selection option Plain, Dotted or Squared graph background Comprehensive Alphanumeric labelling (as illus.) on and around graph enabling rapid, quality presentation.

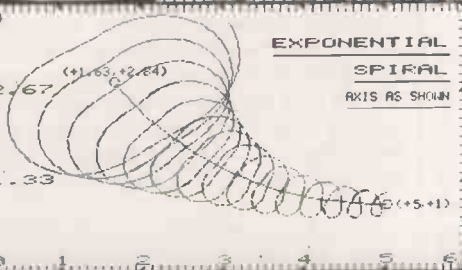

AUTOGRAPH I

AUTOGRAPH is written and supported exclusively by COMPUTACE Ltd and is supplied with extensive documentation and after sales service.

Plots your math formulae in continuous line (as illus.) or in spaced dots £35.50 incl. VAT

AUTOGRAPH II

As Autograph I but includes multiple data point plotting with joining line and marking circle options (as centre graph) £39.50 incl. VAT

• Circle No. 174

Reverse Polish code

THE subroutine described converts a fully-parenthesised expression in algebraic form to its reverse Polish equivalent, writes D Elworthy of Wilmslow, Cheshire. It is relocatable, and should run on any Z-80-based system which uses ASCII codes for A to Z, full stop and parentheses.

The expression must end in a full stop. All other characters are treated as operators except “(,)” and A to Z. In brief, the subroutine works by transferring all operands to the Polish string, and all other symbols to a delimiter list, except “). When this is encountered, a symbol is pulled back from the delimiters and is added to the Polish string, unless it is “(“.

The method can be understood in detail by running it with the registers pointing to parts of the screen. One use that springs to mind is a pre-processor for M5 on Nascom, although a little modification would be necessary.

Register usage is: BC, entry, start address of algebraic string; exit, one beyond end of algebraic string. HL, entry, start address of Polish string; (exit) one beyond end of Polish string.

HL and BC may point to the same places. DE, entry and exit, address of the start of a temporary area. The size of this area cannot be predicted accurately, but it will not exceed the number of operators and ‘(’ symbols plus one.

CVTRPN	LD A ‘	;enter dummy end delimiter	3E 28
	LD (DE) A		12
	INC DE		13
MAIN	LD A (BC)	;pick-up next symbol	0A
	INC BC		03
	CP 40H	;check for range A to Z	FE 40
	JR C NOTOPR	;otherwise it is not an operand	38 08
	CP 5BH		FE 5B
	JR NC NOTOPR		30 04
PUT	LD (HL) A	;add a symbol to the Polish	77
	INC HL		23
	JR MAIN	;more	18 F2
NOTOPR	CP ‘	;not an operand	FE 28
	JR Z LPAREN		28 0D
	CP ‘		FE 29
	JR NZ NOTPAR	;must be an operator	20 0D
	DEC DE	;pull back last symbol from delimiters	1B
	LD A (DE)	;delimiters	1A
	CP ‘	;add to Polish unless parenthesis	FE 28
	JR Z MAIN		28 E4
	DEC DE		1B
	JR PUT		18 EB
LPAREN	LD (DE) A	;add left-parenthesis to delimiters	12
	INC DE		13
	JR MAIN		18 EF
NOTPAR	DEC DE	;point to last delimiter	1B
	CP ‘	;full stop means end	FE 2E
	JR Z ENDIT		28 11
	PUSH AF	;save current symbol	F5
	LD A (DE)	;see what last delimiter was	1A
	CP ‘		FE 28
	JR NZ NOTPA2		20 04
	INC DE	;if ‘(’, append new symbol	13
	POP AF	;to delimiters	F1
	JR LPAREN		18 ED
NOTPA2	LD (HL) A	;previous delimiter to Polish string	77

INC HL			23
POP AF			F1
LD (DE) A	;new symbol to delimiters		12
INC DE			13
JR MAIN			18 C7
ENDIT	LD A (DE)	;final tidying-up	1A
	CP ‘		FE 28
	RET Z		C8
	LD (HL) A		77
	INC HL		23
	DEC DE		1B
	JR ENDIT		18 F7

Binary/decimal/hex

THIS IS A program for binary to decimal to Hex conversion for machine-code buffs, writes N R W Sargent of London, E7. I have formatted the printing specially for resolving bit patterns especially useful with Z-80, and straight conversion coding. The listing is in Sord EBasic.

```

10 / HEXCON
20 / FOR PRINTING ONLY
30 / RE-WRITTEN FROM ORIGINAL SORCERER VERSION OF 1978 *NRWS
40 / 24-01-1981
50 OPEN "SOUTA" FOR OUTPUT AS FILE 1
60 VTCLEAR
70 DIM AS(16)
80 LET AS = "0123456789ABCDEF"
90 LET US = "###"
100 LET D2 = 0
    :LET J = 1
    :LET K = 1
    :LET X = 0
110 GOSUB 360
    :PRINT #1
    :PRINT #1
120 FOR B = 1 TO 2
    : FOR C = 1 TO 2
    :   FOR D = 1 TO 2
    :     FOR E = 1 TO 2
    :       FOR F = 1 TO 2
    :         FOR G = 1 TO 2
    :           FOR H = 1 TO 2
    :             FOR I = 1 TO 2
140               LET B1$ = MID(AS,B,1)
150               LET C1$ = MID(AS,C,1)
160               LET D1$ = MID(AS,D,1)
170               LET E1$ = MID(AS,E,1)
180               LET F1$ = MID(AS,F,1)
190               LET G1$ = MID(AS,G,1)
200               LET H1$ = MID(AS,H,1)
210               LET I1$ = MID(AS,I,1)
220               LET K1$ = MID(AS,K,1)
230               LET J1$ = MID(AS,J,1)
240               LET A1$ = B1$+C1$+D1$+E1$+F1$+G1$+H1$+I1$+" "
250               PRINT #1, TAB(T); A1$;
260               PRINT #1 USING US, D2;
    :             PRINT #1, " "+K1$+J1$+" ";
270               LET T = T+25
    :             IF T > 75 THEN
    :               LET T = 0
    :               PRINT #1
280               IF D2 <> 127 THEN
    :                 GOTO 290
    :               ELSE
    :                 PRINT #1, CHR$(12);
    :                 GOSUB 360
290               LET J = J+1
    :               IF J > 16 THEN
    :                 PRINT #1
    :                 PRINT #1
    :                 LET K = K+1
    :                 LET J = 1
300               LET D2 = D2+1
310               PAGE
320               NEXT I
    :             NEXT H
    :           NEXT G
    :         NEXT F
    :       NEXT E
    :     NEXT D
    :   NEXT C
    : NEXT B
330 PRINT #1, CHR$(12)
340 CLOSE 1
350 END
360 / HEADER ROUTINE
370 LET X = 0
380 PRINT #1, TAB(X); " BINARY DEC HEX";
390 LET X = X+25
    :IF X < 76 THEN
    :  GOTO 380
    :ELSE
    :  PRINT #1
    :  LET X = 0
400 PRINT #1, TAB(X); "-----";
410 LET X = X+25
    :IF X < 76 THEN
    :  GOTO 400
    :ELSE
    :  PRINT #1
    :  LET X = 0
    :  RETURN
NO END MARK

```

Reverse characters

THE RECENT purchase of a 16K RAM pack for my ZX-80 has made me go through my 1K games programs and expand understated games responses, such as "Bang, you are dead" into more expressive, screen-filling white letters on a black background, writes Keith Berry of Newtown, Birmingham. The problem of how to overcome the tedium of having to enter CHR\$(128) for every single black square produced the following idea which works well in practice.

Select a piece of graph paper and mark an area three blocks of 10 wide by two blocks deep. Put your design into this area, blocking in each small square with pencil where black is required in the final display. Number the three vertical blocks of 10, 1-3, and number each horizontal row of small squares, 0-9 — and 0-9 again in the second block down.

You now need 2,000 lines of unused program, say, 3,000 and 4,000. Enter:

```
3000 REM BANG YOU ARE DEAD
3001 PRINT CHR$(128);CHR$(128);10 of
      them, ending with a semicolon
      — Newline —
```

Now Edit, Rubout, 2, Newline, Edit, Rubout, 3, Newline. You now have your first line of black background in lines 3001, 3002, 3003. Continue Editing to give you your next line numbered 3011, 3012, 3013 and then 3021, 3022, 3023, and so on until you arrive at 3091, 3092, 3093.

Repeat for 4001 and you have two blocks of black on which to Edit your white lettering. List 4082, Edit, for example, gives immediate access to the middle column of the second, lower block, line 8.

Using Shift 8, move along the line and Rubout 128 and replace it with 0 wherever a white space should appear. Remember to eliminate the last semicolon in every line whose number ends in three.

Any all black rows should be replaced by, e.g.,

```
FOR J=1 TO 30, PRINT CHR$(128); NEXT J
and similarly a row of CHR$(0) should be
replaced by "(Spaces)". It is a good idea
to Run 3000 after Editing each line, to
check how you are doing.
```

Telephone book

A LIST of names and corresponding telephone numbers can be recorded in code form in two single arrays: X and Y, writes Lloyd Tribello of Basingstoke, Hampshire. These are dimensioned at the beginning of the program. Each separate item in each array can be located using two access vectors; a position vector which gives the position of the first code of the item and a length vector which gives the number of elements in the item.

The first part of the program enables the data to be loaded into the arrays. M is the number of items to be recorded. The arrays P and T store the position vectors for the names and telephone numbers respectively. The arrays L and D store the

length vectors. Subroutine 500 is the LEN subroutine submitted by Eric Deeson, January 1981 ZX-80 Line-up.

After recording the data it is useful to check that it has been entered accurately. The Check Program overwrites lines 90 to 220. All other lines can be removed except for lines 500 to 540 which house the subroutine. The Check Program is initiated by "GOTO 90".

Finally, the Search Program is entered. It will search the X array for an input name and, if the name is found, will locate the corresponding telephone number in the Y array. Both name and number will then be output.

```
90 PRINT "NAME";, "TEL.NO"
100 FOR N=1 TO M
110 FOR I=P(N)TOP(N)+L(N)-1
120 PRINT CHR$(X(I));
130 NEXT I
140 FOR I=1TO17-L(N)-1
150 PRINT " ";
160 NEXT I
170 FOR I=T(N)TO T(N)+D(N)-1
180 PRINT CHR$(Y(I));
190 NEXT I
200 PRINT
210 NEXT N
220 STOP
```

```
10 PRINT "HOW MANY ITEMS?"
20 INPUT M
30 DIM X(100)
40 DIM Y(50)
50 DIM P(M)
60 DIM L(M)
70 DIM T(M)
80 DIM D(M)
90 LET I=1
100 LET J=1
110 FOR N=1 TO N
120 PRINT "NAME?"
130 INPUT A$
140 LET B$=A$
150 GOSUB 500
160 LET L(N)=L
170 LET P(N)=I
180 FOR I=1 TO I+L-1
190 LET X(I)=CODE(A$)
200 LET A$=TL$(A$)
210 NEXT I
220 PRINT "TEL.NO."
230 INPUT A$
240 LET B$=A$
250 GOSUB 500
260 LET D(N)=L
270 LET T(N)=J
280 FOR J=J TO J+L-1
290 LET Y(J)=CODE(A$)
300 LET A$=TL$(A$)
310 NEXT J
320 CLS
330 NEXT N
340 STOP
500 LET L=0
510 LET B$=TL$(A$)
520 LET L=L+1
530 IF NOT B$=""
      THEN GOTO 510
540 RETURN
90 PRINT "NAME SOUGHT?"
100 INPUT A$
110 LET B$=A$
```

```
120 CLS
130 GOSUB 500
140 FOR N=1 TO N
150 IF X(P(N))=CODE(A$)
      AND L(N)=L THEN GOTO 190
160 NEXT N
170 PRINTA$;"NOT FOUND"
180 GOTO 290
190 LET B$=A$
200 FOR I=P(N)+1TOP(N)+L-1
210 LET B$=TL$(B$)
220 IF NOT X(I)=CODE(B$)
      THEN GOTO 160
230 NEXT I
240 PRINT A$,
250 FOR I=T(N)TOT(N)+D(N)-1
260 PRINTCHR$(Y(I));
270 NEXT I
280 PRINT
290 STOP
```

Screen poke

I NOTICE that in ZX-80 Line-up, many games which require movement use Print statements to move a ship, car, etc., writes Mark Lancaster of Carlisle, Cumbria. An example of this is Pete Rowan's animated display in February 1981 *Practical Computing*.

This can be a problem especially if you want something to move right to left across the screen. Here is how to Poke any character on to the screen. The ZX-80 can only Poke where something has already been Printed. So the first thing to do is to Print all the screen, i.e.,

```
10 FOR A=1 TO 736
20 PRINT " ";
30 NEXT A
```

736 is the amount of squares on the screen, but if you obtain an out of screen error code 5, just reduce the 736 until you no longer obtain the error. You can now Poke on to the screen. The top left-hand corner of the screen is Poke number 16485 and the width of the screen is 32 so the Pokes are:

```
16485 TO 16517 first line
16518 TO 16550 second line
```

```
-----
17211 TO 17243 last line
```

The second number in a Poke is the code for a character. Here is a small example program to make a snail crawl along from right to left:

```
10 FOR A=1 TO 550
20 PRINT " _ ";
30 NEXT A
40 LET C=0
50 LET B=16856
60 POKE B,3
70 POKE B-1,136
80 POKE B+(C+1),0
90 POKEB+C,3
100 POKE B+3,0
110 IF C=0 THEN POKE B+2,0
120 LET B=B-1
130 INPUT A$
140 IF C=0 THEN GO TO 170
150 LET C=0
160 GO TO 60
170 LET C=1
180 GO TO 60
```

Lines 10-30 Print enough space on the screen for the program. B is the present position of the snail and decreases by one after every move. Lines 80,100 and 110 remove the snail from the previous move.

The variable C determines the length of the snail's tail while crawling.

The only way to leave the program is when after pressing Newline to slide your finger on to the break key. To see the next move you have to press Newline.

String arrays

ZX-80 BASIC is not too user-friendly when it comes to string handling, writes George Gregson of London SE6. Many programs require the analysis of a string, extraction of a substring or concatenation of strings, none of which is directly possible in ZX-80. An indirect approach is required if such programs are to be written.

An effective technique, which also allows string space to be released from memory, is to substitute an array of ZX-80 character codes for the string. Such an array can then be subjected to numerical, arithmetical or logical processing. Whenever needed, the current string can be output by a PRINT CHR\$(n); loop, n being read from the array.

It is useful to note that the code for null is 1 and the code for space is zero.

```
10 DIM A(50).....or any desired length.
20 LET AS = "STRING"....or 20 INPUT AS.
30 FOR X = 1 TO 50
40 LET A(X) = CODE(AS)
50 LET AS = TLS(AS)
60 IF CODE(AS) = 1 THEN GOTO 80
70 NEXT X
80 LET AS = ""
```

At this point, the array A holds the ZX-80 character codes for STRING and X = 6. You will appreciate that X = LEN(AS) — a new function in ZX-80. Now suppose we wish to add the word BAG to STRING to form the concatenation STRINGBAG:

```
90 LET AS = "BAG".....(or 90 INPUT AS)
100 FOR X = X+1 TO 50
110 LET A(X) = CODE(AS)
120 LET AS = TLS(AS)
130 IF CODE(AS) = 1 THEN GOTO 150
140 NEXT X
150 LET AS = ""
```

Now array A holds the codes for STRINGBAG and X is valued at 9, the new LEN(AS). In both operations, the string space has been released — lines 80 and 150 ensure this, even if the TLS function has not already done so. To output the result:

```
160 FOR Y = 1 TO X
170 PRINT CHR$(A(Y));
180 NEXT Y
190 PRINT
```

Note that the loop variable is now Y to preserve X as LEN(AS). This method can be used to keep track of input characters in, e.g., Hangman-type games, by adding the code of the input letter to array A and outputting the entire array contents before each fresh guess is made.

Two further arrays would be used in Hangman; one to store the codes of the keyword and one of the same length to initially store a row of dash codes. Each dash code would be replaced with the code of a successful guess. I leave it to you to complete the program.

Pursuit ship

IN THIS program the idea is to shoot down the randomly moving space ship in front of you — the inverse space — by lining it up with your rocket sight, writes Chris Carr of Evesham, Worcestershire.

You have five commands; up, down, left or right — U,D,L or R — for thrust and F to fire. As you are in space, you will move in the opposite direction to the thrust and will continue to move until you

counter balance the thrust of your ship.

The graphics routine in this program plots the vertical angle against the horizontal angle (VA and HA) and so could probably be a useful routine for plotting graphs. It is done totally in Basic, without the use of a "memory mapped screen" and so takes slightly longer but is much more reliable. The whole program takes approximately 480 bytes and so it fits easily on a 1K machine.

```
10 LET A$=" PURSUIT SHIP "
20 PRINT
30 FOR J=1 TO 14
40 PRINT CHR$(CODE(A$)+128);
50 LET A$=TL$(A$)
60 NEXT J
70 LET HA=RND(10)-5
80 LET VA=RND(10)-5
90 LET Q=0
100 LET W=0
110 INPUT B$
120 IF B$="R" THEN LET Q=Q-1
130 IF B$="L" THEN LET Q=Q+1
140 IF B$="U" THEN LET W=W-1
150 IF B$="D" THEN LET W=W+1
160 IF B$="X" THEN STOP
170 LET HA=HA+Q+RND(3)-2
180 LET VA=VA+W+RND(3)-2
190 IF B$="F" THEN GOSUB 430
200 CLS
210 FOR L=1 TO 13
220 IF L=7-VA THEN GOTO 270
230 IF L=7 THEN GOTO 350
240 PRINT
250 NEXT L
260 GOTO 110
270 FOR H=1 TO 20
280 IF H=10+HA THEN GOTO 410
290 IF VA=0 AND NOT H=10 THEN PRINT "-";
300 IF VA=0 AND H=10 THEN PRINT "+";
310 IF NOT VA=0 THEN PRINT " ";
320 IF H=20 THEN PRINT
330 NEXT H
340 GOTO 250
350 FOR M=1 TO 20
360 IF M=10 THEN PRINT "+";
370 PRINT "-";
380 IF M=20 THEN PRINT
390 NEXT M
400 GOTO 250
410 PRINT CHR$(128);
420 GOTO 330
430 IF ABS(HA)<2 AND ABS(VA)<1 THEN GOTO 450
440 RETURN
450 CLS
460 PRINT "....." HIT"
470 PRINT "....."RERUN? Y/N"
480 INPUT Z$
490 IF NOT Z$="Y" THEN STOP
500 GOTO 70
```

Re-re-number

I TRIED Michael Whittle's re-numbering program for the UK101 given in the 6502 Special, September 1980 issue writes Graham Thomas of Hatfield, Hertfordshire, only to find several serious problems.

- The program will re-sequence Gotos, etc., only if there are no spaces between the Goto and the line number.
- Contrary to what is stated in the article, the program does not "give the line number for subsequent re-typing" when it needs to replace a

five by a 10, and so on. In fact, it goes on to insert the longer line number, overwriting the GOTO on that line.

- If the program is used to re-sequence a program with more than 100 lines, it aborts on a "BAD SUBSCRIPT ERROR IN LINE 63140", and leaves the program being re-sequenced in an unrecoverable mess.

Here is a fully-debugged copy of the re-numbering program, which overcomes all of the above problems. It will change Gotos, etc., regardless of how many spaces separate the Goto and the line

number. If it needs to replace a short line number by a longer one, e.g., Goto 5 to Goto 10, it prints:

```
CHANGE 5 IN LINE xxx TO 10
```

If the program is used to process a program with more than 100 lines, it prints an appropriate message and restores the program to its original condition before stopping. The program also includes a more comprehensible error message which is printed when a Goto to a non-existent line number is encountered.

In addition, the program can be modified easily to deal with longer programs by changing one of the three variable values in line 63005. ML is the maximum number of lines the program can deal with — limited by the amount of memory available. SP is the line spacing for the re-sequenced program, and OS is the "offset" for the re-sequenced program.

For example, SP=2 and OS=198 would cause the re-sequenced program's lines to be numbered 200, 202, 204, etc. This feature is useful for re-locating a program so that it can be placed at a specific point within another program.

String searcher

HERE IS a program written for the AIM65 but could be adapted for other 6502-based systems by changing the I/O subroutines writes Rob Wilson of Cirencester, Gloucestershire. The program is a string searcher. It will search memory within the entered limits for a given string of up to 10 bytes. It is particularly useful for trying to decipher someone else's machine code.

Line trace

A FEATURE that the Superboard lacks is a Basic trace command writes Jack Pike of Chawston, Bedfordshire. So, here is a machine-code routine which prints the Basic line number every time it changes. It is assumed to be located in the unused RAM starting at \$0222, but the code is re-locatable.

The trace routine works by patching it into the Basic GETCHR routine at \$00BE. That means addresses \$00BE to \$00C1 are changed to 20 22 02 EA Hex, to give a jump to \$0222. The trace is turned on by Poke 550,165 and off by Poke 550,96. By holding down the ESC key, the screen display can be frozen so that you can inspect the line numbers while running the program.

Replace code overwritten in GETCHR:

```
D002 BNE ; IS C3=0?
E6CH INC ; Yes, add 1 to CH
Detect line number change:
60 87 RTN ; Replace 60 with AS to
run trace
C5 E8 CMP ; is line number 10 the
same?
F0 19 BEQ ; yes, branch to test high
85 E8 STA ; store new line number low
A5 88 LDA ; load line number high
85 E9 STA ; store high
```

Loop when ESC key is held down:

```
63000 REM CORRECTED RENUMBERING PROGRAM
63005 ML=100:SP=10:OS=0
63010 DIMA(ML):AD=771:I=0
63020 GOSUB63230:IFLN>62999THEN63060
63025 I=I+1:IFI>MLGOTO63051
63030 N=I*SP+OS:NH=INT(N/256):NL=N-256*NH
63040 POKEAD,NL:POKEAD+1,NH:A(I)=LN
63050 AD=NA:GOTO63020
63051 PRINT"OVER"ML" LINES- RESTORING PROGRAM"
63052 AD=771:FORI=1TOML:NH=INT(A(I)/256)
63053 NL=A(I)-256*NH:GOSUB63230:POKEAD,NL
63054 POKEAD+1,NH:AD=NA:NEXTI:END
63060 AD=771:B=0
63065 B=B+1:GOSUB63230
63070 IFLN>62999THENPRINT"COMPLETE":END
63080 FORJ=AD+2TONA-4:C=FEEK(J)
63090 IFC(>136ANDC(>140ANDC(>160)THEN63220
63100 L=FEEK(J+1):IFL)=48ANDL(=57)THEN63110
63102 IFL=32ANDJ<NA-3THENJ=J+1:GOTO63100
63104 GOTO 63220
63110 C$="":FORK=J+1TOJ+8:C=FEEK(K)
63115 IFC=32ANDK=J+1THENJ=J+1:GOTO63110
63120 IFC<48ORC>57)THEN63140
63130 C$=C$+CHR$(C):NEXTK
63140 L=VAL(C$):FORH=1TOI:IFA(H)=LTHEN63160
63150 NEXTH:PRINT"NON-EXISTANT LINE"L;
63151 PRINT"REFERENCED IN LINE"B*SP+OS
63152 GOTO63210
63160 N$=STR$(H*SP+OS):R=LEN(N$)
63162 IFK-R)=JGOTO63170
63164 PRINT"CHANGE"L" IN LINE"B*SP+OS"TO"N$
63166 GOTO63190
63170 FORX=2TOR
63180 POKEK+X-R-1,ASC(MID$(N$,X,1)):NEXTX
63190 IFK-J-R(=0)THEN63210
63200 J=J+1:POKEJ,32:GOTO63190
63210 IFC=44)THENJ=K:GOTO63110
63212 IFC=32)THENK=K+1:C=FEEK(K):GOTO63210
63220 NEXTJ:AD=NA:GOTO63065
63230 NA=FEEK(AD-1)*256+FEEK(AD-2)+2
63240 LN=FEEK(AD+1)*256+FEEK(AD):RETURN
```

OK

```

; ***** STRING SEARCH PROGRAM *****
; *** SEARCHES FOR A GIVEN HEX STRING *****
; *** R.W.J. WILSON      2/10/80

;ASKS FOR START AND END ADDRESS - HIT ESC TO
;RETURN TO MONITOR.

;ASKS FOR STRING TO BE FOUND (UP TO 10 BYTES)
;ENTER SPACE TO REUSE LAST STRING.

;IF STRING IS FOUND THE ADDRESS WILL BE DISPLAYED
;ENTER SPACE TO CONTINUE OR CR TO RESTART.

;IF STRING IS NOT FOUND 'END' IS DISPLAYED
;ENTER SPACE TO RETURN TO MONITOR OR CR TO RESTART.

;PROGRAM IS RELOCATABLE (NO INTERNAL JUMPS)

;MONITOR SUBROUTINES AND ADDRESSES
CRCK  = $EA24  ;CLEAR DISPLAY
FROM  = $E7A3  ;PRINT 'FROM',GET ADDRESS
TO    = $E7A7  ;PRINT 'TO',GET ADDRESS
OUTPUT=$E97A  ;PRINT A
RD2   = $EA5D  ;READ,SET C IF SP OR CR OR NON-HEX
URAX  = $EA42  ;PRINT HEX IN A AND X
MONIT = $E1B2  ;MONITOR ENTRY POINT
ADDR  = $A41C  ;LOCATIONS USED BY 'FROM' AND 'TO'

0000:  =0
;DATA RESERVATION
0000: STAD  =**+2  ;START ADDRESS
0002: ENAD  =**+2  ;END ADDRESS
0004: STRING =**+10 ;STRING VALUES
000E: COUNT =**+1  ;NUMBER OF BYTES IN STRING.

000F:  = $F40
;GET ADDRESSES
OF40: 20 24 EA START JSR CRCK ;GET START ADDRESS
OF43: 20 A3 E7 JSR FROM ;PUT IT INTO STAD
OF46: AD 1C A4 LDA ADDR
OF49: B5 00 STA STAD
OF4B: AD 1D A4 LDA ADDR+1
OF4E: B5 01 STA STAD+1
OF50: A9 20 LDA #20 ;PRINT SPACE
OF52: 20 7A E9 JSR OUTPUT
OF55: 20 A7 E7 JSR TO ;GET END ADDRESS
OF58: AD 1C A4 LDA ADDR ;PUT IT INTO ENAD
OF5B: B5 02 STA ENAD
OF5D: AD 1D A4 LDA ADDR+1
OF60: B5 03 STA ENAD+1

;GET STRING
OF62: 20 24 EA ENTRY JSR CRCK ;CLEAR
OF65: A0 00 LDY #0
OF67: 20 F0 0F JSR MSGOP ;PRINT 'BYTES?'
OF6A: A0 00 LDY #0
OF6C: 20 5D EA AGAIN JSR RI2 ;READ
OF6F: 90 0C BCC STORE ;VALID ENTRY
OF71: C9 20 CMP #20 ;SPACE?
OF73: F0 16 BEQ REUSE ;YES,CHECK IF FIRST ENTRY
OF75: C9 0D CMP #0D ;CR?
OF77: F0 0C BEQ ENSTR ;YES,END OF ENTRY
OF79: D0 E7 BNE ENTRY ;NON-HEX, REDD ENTRY
OF7B: F0 C3 BRANCH BEQ START ;USED TO AVOID A JUMP FROM
; NOW2 ROUTINE

OF7D: 99 04 00 STORE STA STRING,Y
OF80: C8 INY
OF81: D0 0A CPY #10 ;ALLOW 10 BYTES
OF83: D0 E7 BNE AGAIN
OF85: B4 0E ENSTR STY COUNT ;END OF ENTRY
OF87: C0 00 CHY #0 ;NO ENTRIES?
OF89: D0 08 BNE SEARCH
OF8B: C0 00 REUSE CPY #0 ;FIRST ENTRY?
OF8D: D0 F6 BNE ENSTR ;NO

OF8F: A5 0E LDA COUNT
OF91: F0 CF BEQ ENTRY ;MUST HAVE NON ZERO COUNT

;SEARCH MEMORY FOR THE STRING
OF93: A0 00 SEARCH LDY #0
OF95: B1 00 LDA (STAD),Y ;GET BYTE FROM MEMORY
OF97: D9 04 00 SLOOP CMP STRING,Y ;COMPARE
OF9A: D0 1E BNE INCR ;TRY NEXT MEMORY BYTE
OF9C: C8 INY
OF9D: C4 0E CPY COUNT ;FINISHED STRING?
OF9F: 90 F4 BCC SLOOP

;FOUND MATCH--SHOW ADDRESS
OFA1: 20 24 EA JSR CRCK
OFA4: A5 01 LDA STAD+1
OFA6: A6 00 LDX STAD
OFA8: 20 42 EA JSR WRAX

;GET COMMAND
OFA8: 20 5D EA NOW1 JSR RD2
OFAE: 90 FB BCC NOW1
OFB0: C9 20 CMP #20
OFB2: F0 06 BEQ INCR ;CONTINUE
OFB4: C9 0D CMP #0D
OFB6: F0 88 BEQ START ;RESTART
OFB8: D0 F1 BNE NOW1 ;NON-VALID ENTRY

;INCREMENT AND TEST ADDRESSES
OFBA: 18 INCR CLC
OFBB: A5 00 LDA STAD
OFBD: 69 01 ADC #1
OFBF: 90 04 BCC CHECK
OFC1: E6 01 INC STAD+1
OFC3: F0 0A BEQ ENDMES ;HAVE REACHED $0000
OFC5: A5 02 LDA ENAD ;TEST
OFC7: C5 00 CMP STAD
OFC9: A5 03 LDA ENAD+1
OFCB: E5 01 SBC STAD+1
OFCD: B0 C4 BCS SEARCH ;HAVE NOT REACHED END

;END MESSAGE
OFCF: 20 24 EA ENDMES JSR CRCK
OFD2: A0 06 LDY #2-M1
OFD4: 20 F0 0F JSR MSGOP ;PRINT 'END'
OFD7: 20 5D EA NOW2 JSR RD2 ;GET COMMAND
OFDA: 90 FB BCC NOW2
OFDC: C9 0D CMP #0D
OFDE: F0 98 BEQ BRANCH ;RESTART VIA BRANCH
OFDF: C9 20 CMP #20
OFE2: D0 F3 BNE NOW2 ;NON-VALID ENTRY
OFE4: 4C B2 E1 JMP MONIT ;RETURN TO MONITOR

;MESSAGE DATA
OFE7: 42 M1 .TEXT 'BYTES'
OFE8: 59
OFE9: 54
OFEA: 45
OFEB: 53
OFEF: BF .BYTE $BF ;'?'+$80
OFE8: 45 M2 .TEXT 'EN'
OFE9: 4E
OFEF: C4 .BYTE $C4 ;'D'+$80

;MESSAGE OUTPUT SUBROUTINE
;****$B OF LAST CHARACTER IS 1***
OFF0: B9 E7 0F MSGOP LDA M1,Y
OFF3: 4B PHA
OFF4: 29 7F AND #$7F
OFF6: 20 7A E9 JSR OUTPUT
OFF9: C8 INY
OFFA: 68 PLA
OFFB: 10 F3 BPL MSGOP
OFFD: 60 RTS
;

```

A9 DE LDA ; load ESC key code
CD 0C CMP ; compare to keyboard
F0 FB BEQ ; try again if ESC

Print line number:
A9 4C LDA ; load character "L"
20 E5 A8 JSR ; print "L"
20 5A B9 JSR ; print line number
A5 0F LDA ; load max line length
85 0E STA ; next print on new line
Check line number high, in case:
A5 88 LDA ; with line number high
C5 E9 CMP ; any change in high
D0 E5 BNE ; yes, back to store new
high, etc.
60 RTN ; and return

Writing a Basic program to input this trace is an interesting little problem, because of the required modification to the GETCHR routine while Basic is running. There are, however, ways to accomplish it. Would anyone care to supply a solution?

Variable input

THIS SHORT program is written on a Superboard, though it will probably run

on a Compukit as well, writes Jonathan Turpin of Stanford-Le-Hope, Essex. The program is designed to be used when you are in Basic and want to input a variable without the problem of hitting Return and jumping out of the program.

The routine also operates on the Basic input routine and does not allow a carriage return unless the input buffer is partly full.

Here is the disassembled listing:
0222 20 BA FF JSR \$FFBA Call keyboard/
cassette input
routine
0225 C9 0D0
CMP \$0D0 Is the char-
acter a carriage
return?
0227 F0 01 BEQ \$022A If so, see if any-
thing in buffer
0229 60 RTS If not, return with
character
022A E0 00 CPX \$000 Is the input buffer
empty?
022C F0 F4 BEQ \$0222 If it is, recall the
input routine
022E 60 RTS If not, return with
the character

The basic listing is:

```

10 FOR I = 546TO558
20 READA:POKEI,A
30 NEXTI
40 REM Alter Input Vector (HEX 218)
50 POKE536,34:POKE537,2
60 END
70 DATA32,186,255,201,13,240,01
80 DATA96,224,0,240,244,96

```

Square puzzle

THIS PROGRAM emulates the simple puzzle which has 15 sliding squares mounted in a frame which is so designed to allow only one square at a time to be moved writes PJ Cooper of Southminster, Essex. Each of the 15 squares has a different letter — from A to O — printed on its face and the object of the puzzle is to place the squares in alphabetical order.

Although it all sounds simple, I can assure you it is not and if you have a day to spare — one hour to enter the program and the rest to solve the puzzle — then this is the one for you.

(continued on next page)

(continued from previous page)

It has been written for the standard Superboard II and contains many peeks and pokes which owners of other machines may find difficult to disentangle. Those enterprising UK101 users UK 101 should not find it too difficult. As a guide the screen display for the Superboard II more or less starts at 53285, top left, and finishes at 54140, bottom right, with 32 locations per line.

Incidentally, the program presents a different puzzle each time it is run.

Line numbers

THERE ARE thousands of tips and ideas begging to be explored writes Peter Jones of Standish, Lancashire.

For instance, it is not difficult to write a file-search program whereby after

inserting the required List Line Number, the computer will search through the incoming tape listing, until the required List Line Number appears.

On receiving this List Line Number the computer will either: carry-out the instructions in the List Line or print out the whole List Line.

Can anyone suggest a program for the Superboard in which the computer will do all the searching, etc., at the same time leaving the screen blank?

List route

STEVE PURDY'S solution to the List problem on the Superboard in the February 1981 6502 Special may have left readers wondering why I wanted the program to continue execution after LIST.

With a routine using the facility, RUN 63000 will save your Basic program up to line 62998 on tape, so that on re-loading, the program runs automatically:

```
62999 END
63000 SAVE : POKE 4,194 : POKE 5,165
63100 LIST — 62998 : POKE 4,195 : POKE
5,168
63200 PRINT : PRINT "0 POKE 515,0":
PRINT "RUN
63300 POKE 517,0
```

To save the routine with the program, remove the — 62998 after LIST. The Superboard is very reliable on saving and loading but occasionally you obtain a spurious single-digit line number, i.e., from 0 to 9, from the rubbish on the tape before the load starts. This problem can be overcome by changing line 63200 to

```
63200 PRINT : PRINT "0 POKE 515,0 :
GOTO first line number " : PRINT"
RUN
```

```
5 FORZ=0TO25:PRINT:NEXTZ
10 GOSUB455
15 Y=169
20 FORX=53295TO53308
25 POKE X,Y:POKE X+32,Y:POKE X+704,Y:POKE X+736,Y
30 NEXTX
35 FORX=53359TO53967STEP32
40 POKE X,Y:POKE X+13,Y
45 NEXTX
50 A=53425
55 FORA=ATO A+9STEP3
57 IFA>53911 THEN85
60 GOSUB100
65 NEXTA
70 A=A+148
80 GOTO55
85 POKE53914,96
90 A=53425
95 GOTO130
100 POKEA-65,189:POKEA-64,135:POKEA-63,190
105 POKEA-33,136:POKEA-31,143:POKEA-1,136
110 POKEA+1,143:POKEA+31,136:POKEA+33,143
115 POKEA+63,190:POKEA+64,128:POKEA+65,189
120 POKEA,96
125 RETURN
130 REM**RANDOM LETTERS**
135 X=1:Y=1
140 A$="ABCDEFGHIJKLMNO"
145 B=INT((1-14)*RND(1)+14)
150 B$=RIGHT$(A$,14-B)+MID$(A$,2,B)+LEFT$(A$,1)
155 X=X+1:A$=B$:IFX<25 THEN145
160 REM**PUT IN SQUARES**
165 FORA=ATO A+9STEP3
170 X$=MID$(A$,Y,1)
175 Y=Y+1:IFY>16 THEN200
180 Z=ASC(X$)
185 POKEA,Z
190 NEXTA
195 A=A+148:GOTO165
200 REM**KEYBOARD**
205 POKE11,34:POKE12,2
210 DATA32,0,253,141,128,2,96
215 FORX=546TO552:READC:POKE X,C:NEXTX
220 GOSUB500
225 X=USR(X)
230 D=PEEK(640):REM**SQUARE**
235 IFD>64 ANDD<80 THEN245
240 GOTO225
245 REM**SEARCH FOR SQUARE**
250 A=53425
255 FORA=ATO A+9STEP3
260 IFPEEK(A)=D THENPOKEA-32,58:GOTO285
265 NEXTA
270 A=A+148
275 IFA>53914 THEN250
280 GOTO255
285 GOSUB560
290 X=USR(X)
295 D=PEEK(640):REM**DIRECTION**
300 IFD>48 ANDD<53 THEN310
305 GOTO290
310 REM**VALIDATE MOVE**
315 IFD=49 ANDPEEK(A-160)=96 THEN355
```

```
325 IFD=50 ANDPEEK(A+160)=96 THEN380
335 IFD=51 ANDPEEK(A-3)=96 THEN405
345 IFD=52 ANDPEEK(A+3)=96 THEN430
350 GOSUB595:POKEA-32,32:GOTO220
K
355 REM**MOVE UP**
360 E=A:F=PEEK(A)
365 IFA=E-160 THENPOKEE,96:GOTO220
370 GOSUB635:A=A-32:GOSUB100
375 POKEA,F:FORT=0TO500:NEXTT:GOTO365
380 REM**MOVE DOWN**
385 E=A:F=PEEK(A)
390 IFA=E+160 THENPOKEE,96:GOTO220
395 GOSUB635:A=A+32:GOSUB100
400 POKEA,F:FORT=0TO500:NEXTT:GOTO390
405 REM**MOVE LEFT**
410 E=A:F=PEEK(A)
415 IFA=E-3 THENPOKEE,96:GOTO220
420 GOSUB635:A=A-1:GOSUB100
425 POKEA,F:FORT=0TO500:NEXTT:GOTO415
430 REM**MOVE RIGHT**
435 E=A:F=PEEK(A)
440 IFA=E+3 THENPOKEE,96:GOTO220
445 GOSUB635:A=A+1:GOSUB100
450 POKEA,F:FORT=0TO500:NEXTT:GOTO440
455 PRINT" SQUARES"
460 PRINT" -----"
465 PRINT:PRINT:PRINT
470 PRINT" KEY 1=":CHR$(16):PRINT
475 PRINT" KEY 2=":CHR$(20):PRINT
480 PRINT" KEY 3=":CHR$(22):PRINT
485 PRINT" KEY 4=":CHR$(18):PRINT
490 FORX=0TO10:PRINT:NEXTX
495 RETURN
500 REM**INSTRUCTION**
505 D$="INPUT SQUARE TO MOVE"
510 Y=1
515 FORX=54119TO54138
520 X$=MID$(D$,Y,1)
525 POKE X,ASC(X$):Y=Y+1:NEXTX
530 RETURN
560 REM**INSTRUCTION**
565 D$="NOW INPUT DIRECTION "
570 Y=1
575 FORX=54119TO54138
580 X$=MID$(D$,Y,1)
585 POKE X,ASC(X$):Y=Y+1:NEXTX
590 RETURN
595 REM**ERROR**
600 D$="THIS IS NOT POSSIBLE"
605 Y=1
610 FORX=54119TO54138
615 X$=MID$(D$,Y,1)
620 POKE X,ASC(X$):Y=Y+1:NEXTX
625 FORT=0TO2000:NEXTT
630 RETURN
635 REM**SQUARE DELETE**
640 POKEA-65,32:POKEA-64,32:POKEA-63,32
645 POKEA-33,32:POKEA-31,32:POKEA-1,32
650 POKEA+1,32:POKEA+31,32:POKEA+33,32
655 POKEA+63,32:POKEA+64,32:POKEA+65,32:POKEA,32
660 RETURN
K
```

SUN

NOW THE INTEGRAL SYSTEM WITH PERFORMANCE, QUALITY, EXPANDABILITY & **RELIABILITY**; ESSENTIAL FOR A BUSINESS SYSTEM.

FULL 12 MONTHS WARRANTY



ABC 24:— 620K BYTES ON DUAL MINI FLOPPY DISKS

ABC 26:— 2.3 MBYTES ON DUAL 8 INCH FLOPPY DISKS

LOOK AT THESE STANDARD AI FEATURES, INCLUDED IN THE PRICE.

- * DOSKET OPERATING SYSTEM
- * FORTRAN IV
- * UTILITIES
- * DIAGNOSTICS

- * BASIC INTERPRETER/COMPILER
- * Z80 ASSEMBLER
- * LIBRARY
- * EDIT (& MORE)

HARDWARE

- * 64K BYTES RAM
- * REAL-TIME CLOCK (INTERVAL TIMER)
- * GREEN SCREEN
- * SEPARATE KEYBOARD
- * SECURITY LOCK
- * HARD DISK AVAILABLE
- * MULTI USER HARD DISK AVAILABLE SOON

- * SEPARATE SCREEN BUFFER
- * IEEE 488 INTERFACE BUS
- * LARGE GRAPHICS SET
- * 12 FULL RS232 PORTS
- * 16 SEPARATE USER DEFINABLE KEYS
- * DMA FOR HARD DISK ATTACHMENT

Ai ELECTRONICS ABC 26 £4750 Ai ELECTRONICS ABC 24 £3350

OPTIONAL SOFTWARE

- | | |
|-----------------------------|------|
| * CP/M | £150 |
| * SALES LEDGER | £200 |
| * PURCHASE LEDGER | £200 |
| * NOMINAL LEDGER | £200 |
| * STOCK CONTROL | £200 |
| * WAGES/SALARIES | £200 |
| * ABOVE INTEGRATED PACKAGES | £800 |
| * WORDSTAR & MAILMERGE | £350 |
| * ISR DATABASE | £400 |

ALL WITH SUPPORTING DOCUMENTATION AND LICENSING AGREEMENTS.

ALL PRICES EXCLUDE VAT

A NATIONAL DEALERSHIP NETWORK WILL BE OPERATIVE FOR THIS POWERFUL MACHINE SOON. IF YOU ARE AN ESTABLISHED AND PROFESSIONAL DEALER, WISHING TO APPLY, PLEASE CONTACT:

SUN Computing Services Ltd

138 Chalmers Way
North Feltham Trading Estate
Feltham
Middlesex

TEL. 01-751 5044 TWX 8954428 SUNCOM 6

0 to 60^{ch's} in one second



THE RICOH 1600S

If it's high performance you're looking for, the Ricoh 1600S is for you, offering an amazing 60 characters in just 1 second. An updated version of the tried-and-tested 1600, the new S model has been re-designed and fitted with all sorts of extras. Yet one thing hasn't changed — the price, making the 1600S cheaper than any equivalent model on the market. This superb performer incorporates the Z80 micro-processor, auto bidirectional printing and look-ahead logic, increasing speed and efficiency. Other capabilities include proportional spacing, graph plotting and word processing enhancements. The printer includes a standard centronics interface, and RS232 and IEEE options are available.

The Ricoh 1600S is available only from Micropute and their authorised dealers, all backed up with a nationwide service network. If you're interested in the 1600S either as a customer or as a dealer, send the coupon now.

Please send me details on the Ricoh 1600S

Name

Position

Company

Address

Tel. No.

RICOH 1600S THE PERFORMANCE HAS RISEN — THE PRICE HASN'T

FEATURES COMPETITORS

	DIABLO 630	QUME SPRINT 5	SPIN- WRITER	RICOH RP.1600 (10 DATA)	RICOH RP.1600S
PRINT SPEED (CPS)	40	45/55	55	60	60
PRINT ELEMENT	DAISY- WHEEL	DAISY- WHEEL	THIMBLE	DOUBLE DAISY- WHEEL	DOUBLE DAISY- WHEEL
AUTO BIDIRECTIONAL	No	No	Yes	No	Yes
AUTO LOGIC SEEKING	Yes	No	Yes	No	Yes
PROPORTIONAL PRINT CAPABILITY	Yes	Yes	Yes	No	Yes
EXTENDED CHARACTER SET	No	No	Yes	Yes	Yes
LETTER QUALITY PRINT	Yes	Yes	Yes	Yes	Yes
CUSTOM INTER- FACE OPTION	No	No	No	No	Yes
PRICE	£1675	£1950	£1950	£1450	£1450

The above information was gathered from distributors and abstracted from their current literature. Prices shown are those advertised at the present time.

MICROPUTE
microcomputer systems

Comminque Place, 9 Prestbury Road, Macclesfield, Cheshire.
SK10 1AU. Tel: Macclesfield 612759

• Circle No. 176



The Onyx C8000 Series

The C8000 Series is a compatible family of microprocessor-based systems, designed for business and scientific applications.

These powerful general-purpose systems combine processor, memory, fixed 10 Mbyte or 18 Mbyte 8 in. disk (expandable to 76 Mbytes) and cartridge tape driver - all within one low profile enclosure.

The C8001 is an 8 bit Z80A* system with up to 256 Kbytes of memory for 1-5 users. And is easily expandable to the more powerful 16 bit C8002 configuration, with 256 Kbytes to 1 Mbyte of memory handling up to 8 users.

Based on the Z8000* processor, the C8002 may be connected to a high speed local network for further expansion.

Industry compatible versions of COBOL, PASCAL, BASIC, CBASIC2*, FORTRAN and C are available on OASIS*, CP/M*, MP/M* and UNIX* operating systems. Also available are packages for communications, data base management, word processing and business applications.

ONYX

Onyx Distribution Ltd
Unit 58, Suttons Park Avenue, Earley, Reading
Berkshire RG6 1AZ. Tel: (0734) 664343/6

*Z80A and Z8000 are trade marks of Zilog Inc. CP/M and MP/M are trade marks of Digital Research Inc. OASIS is a trade mark of Phase One Systems Inc. UNIX is a trade mark of Bell Telephone Laboratories. CBASIC2 is a trade mark of Compiler Systems Inc.

Sig net

If the front panel....

and the basic specification...

- * 4MHz Z80 processor and full 64K RAM
- * 2 or 4 dual density mini floppy disk drives
- * Serial RS 232 printer and VDU interfaces
- * CP/M compatible

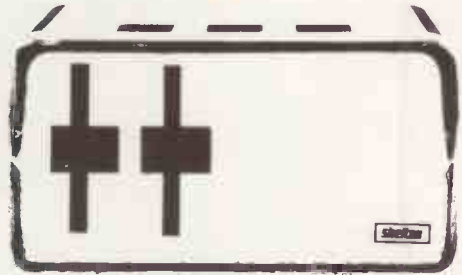

make you think you've seen it all before, then take a closer look at the...

Sig net range of microcomputers from shelton

A confident new approach to micro design, which combines the cost advantages of single board computers with the flexibility of bus systems

and the price! **£1299** for a twin-drive system including CP/M expandable to

- * Multi-user/multi-processor operation
- * Virtually unlimited flexible or hard disk storage capacity
- * Support an almost unlimited number of other peripherals and users under MP/M, CP/NET or CP/NOS

OEMs — take advantage of the outstandingly low cost of Sig net modules



CPU-RAM: 4 MHz, Z80, 64K and hard disk controller interface	£299.50
FDC: supports 4 single, double or quad density drives — 8 or 5 1/4 in.	£159.50
TWO-SER: twin serial I/O RS 232, 80baud — 19.2kbaud (64kbaud synchronous)	£89.50
PSU-CPU: modules power supply	£49.50
PSU-FDD: disk drive power supply	£69.50

Sig net microcomputers
 another leading idea from
 shelton THE RESOURCE CENTRE

shelton

Shelton Instruments Ltd.,
 22-26 Copenhagen Street,
 London N1 0JD.
 01-278 6273/4
 TELEX 869559 GECOMS G

Sig net is a trade mark of Shelton Instruments Ltd.

• Circle No. 178

Video Genie ideas

A FEW months ago I bought a Video Genie computer, writes Simon Goodwin of Hereford. As many will know, this machine is based on the Tandy TRS-80 level 2 computer, with a few enhancements — a second cassette port is standard, as is a built-in tape recorder on port 1.

The dreaded TRS-80 keyboard bounce has been largely eliminated. A Video Genie does not return to a cold-start when the re-set key on the back of the box is pressed; it returns to Basic with variables and program intact. This feature makes a program crash less likely than on a Tandy machine. It can, however, be inconvenient if the user wants to change the area of protected memory on the computer. The reason for the potential inconvenience is that, according to the manual, the machine must be turned-off and turned-on — after a 10-second wait to allow the power supply to discharge — to return to the prompt requesting reserved memory size.

In fact, it is easy to branch to this prompt — clearing the current program — from Basic without having to turn the machine on and off. Enter System new-line followed by slash zero new-line to return to the system start-up prompt. You can now enter the starting address for reserved memory as if you had just turned the machine on.

The instruction slash zero tells the Video Genie monitor to execute the program at location zero. This is where the Basic ROM starts, and where the Z-80 looks for the first instructions when it is turned-on. Obviously, it is much better for the system if you can re-start it without having to turn it on and off — chips are at their most vulnerable at these times.

There are a few characters which apparently cannot be obtained directly from the Video Genie keyboard. Underline, backslash, up arrow, close square bracket, tabulator and clear screen can be obtained, according to the manual, only by using the CHR\$() function. In fact, a look at the TRS-80 technical manual shows that it should be possible to generate all these codes by pressing combinations of keys.

Try holding down the "Z" and "2" keys with your left hand. With those keys still down, type two backspaces to remove the last two characters from the display — now tap "3" gently, with "Z" and "2" still depressed. If you were gentle, an open square bracket character "[" will have appeared. If you were too fierce the "[" will still have been produced, but it will be followed by a "3". You can delete the "3" with another backspace, still holding "Z" and "2" down.

So far, that may not seem very useful — you could have produced a "[" just by typing the ESC key. Still, hold down "Z" and "2" again, type two backspaces,

followed by a light press on "4". This should produce a backslash "\ " symbol, which used to be unobtainable from your keyboard. Keep the first two keys down and tap "5" — you produce the ubiquitous close square bracket "]". Try "6" — it produces another untypable character, an up-arrow or '^'. Finally, still with "Z" and "2" down, press "7" briefly to produce an underline "_" symbol. This procedure may sound complex, but with practice it is really very simple — "Z" and "2" are used as a kind of extra "shift" key.

Those functions can be very useful when entering programs — particularly ones that use graphics generated from text symbols. When using the line editor, a different set of shift keys must be used to have the same effect — in fact, other combinations of keys can be used to provide the shift — "Z" and "2" were chosen for their proximity on the keyboard.

Control codes can also be produced by a similar technique. Hold down "shift" and "CTRL" together — they should not produce any characters on their own. Now press "I". This combination produces a TAB function and prints a variable number of spaces to take the cursor up to the start of the next eight-character wide tabulator field. This is very useful when tidying listings or using the editor assembler, as it allows you to spread information easily into neat columns. If you try to enter a TAB while in insert mode in the Basic editor, you will produce a rather less useful reverse line-feed.

Obviously, it is possible to type the entire range of characters available on a Video Genie by pressing groups of keys. TRS-80 users may also find this useful, though as their keyboard has more keys on it, the advantage will be correspondingly less. I am mystified by the way a shifted zero on the Video Genie produces a space, CHR\$(32). It must be the most

useless extra way yet invented to type a character.

Finally, I would like to recommend from personal experience the TRS-80 manuals to owners of Video Genies. The Video Genie manuals are clear, but the Basic manual is definitely too short to cover all the details. I have found the TRS-80 level 2 Basic manual excellent as a supplement to this — it is comprehensive, properly indexed in its second edition and contains many useful routines and programs illustrating functions in Basic and simple machine code.

Faster conversion

IT GRIEVED me to see the Decimal-to-Hex conversion program by N Brickell published in your January 1981 Tandy Forum, writes John Leach of Deal, Kent. Apart from writing a very clumsy program, Brickell never asked himself: What if? What if a negative number is entered? What if the number is > 65535?

A little thought and ingenuity will soon give a far more flexible subroutine, including the vital error flags, which can be tested for in the main program on return from the subroutine, in a mere eight lines of code.

Practical Computing obviously tries to encourage good programming style, for which many thanks. The Hex program falls down badly; lines 30 to 64 should be in a simple loop — see lines 1110 to 1130 in my program — while lines 100 to 150 are quite absurd. All that is needed is

100 BS=CHR\$(VAL(AS)+55):RETURN
I dare say the program works as listed, but no wonder it is so slow. Suppose you wanted to convert 1,000 decimal numbers. Far too many published programs contain long lists of If Then statements, which can nearly always be changed to a short loop, utilising a simple arithmetic conversion as in my example, or by using a look-up table in DATA. Apart from saving memory, the program can normally be made to run much faster. □

```

1000 REM Convert a decimal number to a Hexadecimal string with error flags
1010 REM AZ$ = Output string
1020 REM LZ = Length of output string (defined in main program)
1030 REM EZ = Error flag (EZ = 0 if conversion satisfactory)
1040 REM FZ = Negative number flag (FZ = 1 if negative, otherwise = 0)
1050 REM NZ = Decimal number to be converted (not changed by the subroutine)
1060 AZ$="": EZ=0: IF LZ < 1 THEN EZ=1: RETURN: REM Length not defined
1070 QZ=NZ: FZ=0: KZ=16*(LZ-1): IF QZ >=0 GOTO 1100: REM Check sign
1080 FZ=1: IF ABS(QZ) > KZ*8 THEN EZ=2: RETURN: REM Negative number out of range
1090 QZ=KZ*16 + QZ: REM Adjust QZ when negative
1100 QZ=INT(QZ): DZ=48: REM Get ready for conversion loop
1110 FOR IZ=1 TO LZ: TZ=INT(QZ/KZ): IF TZ>15 THEN EZ=2: RETURN: REM Out of range
1120 AZ$=AZ$+CHR$(DZ+TZ-7*(TZ>9)): REM Convert Hex value to ASCII
1130 QZ=QZ-KZ*TZ: KZ=KZ/16: NEXT IZ: RETURN
1140 REM For TRS 80 substitute FIX for INT
1150 REM IZ, KZ, TZ and QZ are temporary variables within the subroutine
1160 REM Line 1120 uses Microsoft BASIC logical operator (TZ>9)
1170 REM If this is not allowed in other versions, change to

```

```

1120 JZ=TZ: IF JZ>9 THEN JZ=JZ+7
1125 AZ$=AZ$+CHR$(DZ+JZ)

```

```

1190 REM All variables end in Z to avoid confusion with main program variables
1200 REM Sample program

```

```

10 INPUT "LENGTH, NUMBER ";LZ,NZ
20 GOSUB 1000
30 IF EZ = 0 THEN PRINT AZ$: GOTO 10
40 PRINT "ERROR TYPE ";EZ: GOTO 10

```

Pet sort by selection

THIS PROGRAM uses a sort by selection procedure, writes Simon Letts of Run-corn, Cheshire. That is, it searches the unsorted array for the lowest item — the data is ASCII coded. When this is found it is swapped with the item at the bottom of the array. The base address of the unsorted array is then incremented.

In this way, a sorted array is built-up at the bottom of the unsorted one — which decreases in size as each item is removed from it. The method was chosen for its simplicity rather than its efficiency and could be improved in that respect. For example,

Unsorted array	1st pass	2nd pass	3rd pass
1 Peter	Andrew	Andrew	Andrew
2 John	1 John	Charles	Charles
3 Andrew	2 Peter	1 Peter	John
4 Charles	3 Charles	2 John	1 Peter

In fact, the program does not move the data itself, which could be very lengthy, but when sorting the data, it moves the addresses of that data. Each one is only three bytes long and the Pet holds them all together above the Basic program and variables.

Null strings

The program is designed to leave null strings in position in the array and to place a longer string after a shorter one that is the same for the length of the shorter. For example,

Unsorted array	1st pass	2nd pass	3rd pass
Smith A B	Jones P	Jones P	Jones P
null	null	null	null
Jones P	Smith A B	Smith A B	Smith A
Smith A	Smith A	Smith A	Smith A B

The program is stored in the second cassette buffer but is completely re-locatable as it uses only relative addressing. The program uses some of the zero-page memory normally retained for cassette handling work space. Due to considerations of size, speed and simplicity in use, this version of the sort can only handle arrays of up to 256 — 0 - 255 — elements.

Call from Basic

The routine must be called by the following line of Basic:

POKE 18 0,C: NMS(0) = NMS(0) : SYS(826) where C is the length of the array and NMS is the name of the array which can be anything.

The POKE puts the length of the array into the zero-page work space and setting the zero array element equal to itself puts the address of the array into zero page address 68-69 — Hex 0044-0045 — which is the current variable address where it can then be found by the machine-code routine. SYS(826) calls this routine.

Program notes

Further notes may be found in the listing.

Workspace use — hex addresses, all in zero page
00B4 Array length, decimal address 180



00B5-B6 Base address of unsorted array
00B7-B8 Address of lowest element so far in this pass
00B9-BA Address of next element to be checked
00BB-BD Address of data in lowest element
00BE-C0 Address of data in next element to be checked
00B1-B3 Temporary storage for address swap

Notes:

Addresses 033A - 033F saves the 6502 registers on the stack.

0340 - 0356 loads the address of the array into the zero page workspace.

0357 - 0363 increment the address of the present array element to form that of the element next to be compared.

0364 - 0372 loads the addresses of the data to be compared — the actual strings.

0373 - 037A are either of the strings null? If so, do not compare.

037B - 0383 checks if every character in either string has been compared.

0384 - 0393 compare the next character of each string. Try next characters if these two are the same. Try next string if lowest value is still the lowest. Otherwise, (038C), store address of present element in space for lowest element.

0394 - 0396 decrement length of array left to be searched. Try next string if end of array not reached.

0397 - 03A9 swap addresses of lowest element and element at bottom of unsorted array. This builds up the sorted array.

03AA - 03B6 increment base address of unsorted array by three — this shortens the unsorted array and lengthens the sorted one.

03B7 - 03BA decrement unsorted array length register, continue with sort if end of array not yet reached.

03BB - 03C1 restore 6502 registers from the stack and return to Basic.

READY.

B*	PC	IR0	SR	AC	NR	YR	SP
..	0401	E62E	32	04	5E	00	F8
..	033A	08	48	8A	48	98	48
..	0342	44	85	B5	A5	45	85
..	034A	B4	A5	B5	85	E7	85
..	0352	B6	85	B8	85	EA	18
..	035A	69	03	85	B9	A5	BA
..	0362	85	BA	A0	02	B1	E7
..	036A	00	E1	B9	99	BE	00
..	0372	F3	A5	BE	F0	1D	A5
..	037A	19	08	C4	BE	F0	0C
..	0382	F0	10	B1	BC	D1	BF

038A	90	08	A5	E9	85	B7	A5	BA
0392	85	B8	CA	D0	C0	A0	02	B1
039A	B7	99	E1	00	E1	E5	91	B7
03A2	B9	E1	00	91	B5	88	10	EF
03AA	18	A5	B5	69	03	85	B5	A5
03B2	B6	69	00	85	B6	C6	B4	D0
03BA	8E	68	A8	68	AA	68	28	60

READY.

033A	08	PHP
033B	48	PHA
033C	8A	TYA
033D	48	PHA
033E	98	TYA
033F	48	PHA
0340	D8	CLD
0341	A544	LDA 44
0343	85B5	STA B5
0345	A545	LDA 45
0347	85B6	STA B6
0349	A5B4	LDX B4
034B	A5B5	LDA B5
034D	85B7	STA B7
034F	85B9	STA B9
0351	A5B6	LDA B6
0353	85B8	STA B8
0355	85BA	STA BA
0357	18	CLC
0358	A5B9	LDA B9
035A	6903	ADC #03
035C	85B9	STA B9
035E	A5BA	LDA BA
0360	6909	ADC #09
0362	85BA	STA BA
0364	A002	LDY #02
0366	B1B7	LDA (B7).Y
0368	99B000	STA 00B0.Y
036B	B1B9	LDA (B9).Y
036D	99B000	STA 00BE.Y
0370	88	DEY
0371	10F3	BPL 0366
0373	A5BE	LDA BE
0375	F01D	BEQ 0394
0377	A5BE	LDA BE
0379	F019	BEQ 0394
037B	C8	INY
037C	C4BE	CPY BE
037E	F00C	BEQ 038C
0380	C4BE	CPY BE
0382	F010	BEQ 0394
0384	B1BC	LDA (BC).Y
0386	D1BF	CMP (BF).Y
0388	F0F1	BEQ 037B
038A	9008	BCD 0394
038C	A5B9	LDA B9
038E	85B7	STA B7
0390	A5BA	LDA BA
0392	85B8	STA B8
0394	CA	DEX
0395	D0C0	BNE 0357
0397	A002	LDY #02
0399	B1B7	LDA (B7).Y
039B	99B100	STA 00B1.Y
039E	B1B5	LDA (B5).Y
03A0	91B7	STA (B7).Y
03A2	99B100	LDA 00B1.Y
03A5	91B5	STA (B5).Y
03A7	88	DEY
03A8	10EF	BPL 0399
03AA	18	CLC
03AB	A5B5	LDA B5
03AD	6903	ADC #03
03AF	85B5	STA B5
03B1	A5B6	LDA B6
03B3	6909	ADC #09
03B5	85B6	STA B6
03B7	C6B4	DEC B4
03B9	D08E	BNE 0349
03BB	68	PLA
03BC	A8	TYA
03BD	68	PLA
03BE	AF	TAX
03BF	68	PLA
03C0	28	PLP
03C1	60	RTS

Miniassembler facility

I WAS very disappointed to discover that the 48K Europlus lacked the mini-assembler facility writes David Kyte of Bristol. When flicking through back copies of *Practical Computing*, I noticed letters concerning re-locating the program.

My first problem was finding a copy of the listing, there was no copy in the latest manuals which accompany the system. I found it in the old manual, a copy of which I obtained from my local dealer. I believe there is also a listing in the 2020 manual.

A point not mentioned in the letters in *Practical Computing* is the influence of DOS. At first I tried to re-locate it at \$b000 as the program is only \$166 bytes long. The effect of trying to save the program on disc and watching the system crash, coupled with DOS overwriting the code in memory is crippling. After several fruitless attempts I offer the following advice.

DOS alters high memory thus:

System	High memory	DOS high memory
48K	\$bfff	\$9600
36K	\$8fff	\$6600
32K	\$7fff	\$5600
24K	\$5fff	\$3600
20K	\$4fff	\$2600
16K	\$3fff	\$1600

The problem is solved if the program is located from address \$0800 to \$0966. This involves changing the following segments of code

Address	Old code	New code
\$f535:	4c 95 f5	— 4c 95 08
\$f559:	4c 95 f5	— 4c 95 08
\$f5bd:	20 34 f6	— 20 34 09
\$f5d5:	20 34 f6	— 20 34 09
\$f5e5:	20 34 f6	— 20 34 09
\$f631:	4c 5c f5	— 4c 5c 08
\$f666:	4c 92 f5	— 4c 92 08

The rest of the code is identical. The miniassembler is run by typing \$0966.

Cross-referencing

A QUICK glance at E McGeough's Cross-Reference program, Apple Pie, January 1981, showed that it did not handle names more than 4 characters very well and was limited to 999 references writes Neil Lomas of Crewe. It seemed rather slow, however, even for Basic — a program containing 878 references took 37 minutes 15 seconds.

The most obvious cause of its slow speed was that it sat on top of the program being analysed. Every Goto caused the whole program to be scanned — and there are very many Gotos during a sort. Removing of the program once the references had been assembled seemed to provide the answer.

Although it may appear a disadvantage to have to preserve the string array on disc while the program is changed, this produced a significant reduction in the overall time and also opened the way to removing the .999 limit. Instead of assembling all the strings and writing them to one file, a new file is written whenever a certain number of references, 512, have

been assembled. The files are sorted independently and then merged.

Further savings resulted from clearing string array elements to null as soon as they were no longer required — reducing the frequency of garbage collection — and by sorting an array of pointers instead of the strings themselves. I was a little surprised at this, as I had some vague notion that two strings with the same value were merely two pointers to the same string. If there are circumstances where this is true, it does not happen here — otherwise sorting a string array would only amount to swapping pointers.

Finally, the printer had a habit of stopping for long periods while garbage collection took place. Assembling each print line in memory is a high-speed garbage generator — unloading the assembly job on to the printer cleared the problem completely.

Since this process now destroys the program being analysed, it is first saved in a file called In case of accidents. After the cross-reference has been produced, In case of accidents may be loaded if necessary, lines 63955 onwards deleted, and the program saved under its proper name.

If the program to be analysed has been run, Clear the data areas before running the cross-reference. If any program has reduced high memory, re-boot DOS and re-load the program. Failure to do this will greatly slow the process, if it does not stop it altogether. Note that the last character of a long name is now saved, to distinguished \$ and %.

The program as listed analysed McGeough's program in 23 minutes 36 seconds, a saving of more than 36 percent. Although the original listed the program as well, the times quoted compare like with like. To accelerate the initial assembly phase, try removing the progress print and assembling the arrays directly to disc. This would involve replacing the individual file sizes and continuation markers with a separate index.

A note about the printing: the protocol used is for a parallel printer which adds its own line feed, actions received LFs, and has a reverse LF facility. It can be adapted for any parallel printer except one which adds LFs and cannot reverse. In that case, the program must be changed to begin a new print line for each disc file — even where that results in repeating a variable name — or to revert to the original method of assembling print lines in memory. If you have a serial printer, this may not apply.

```

30 REM XREF
20 REM RUNNING THIS PROGRAM WILL SAVE
30 REM THE LINES 1000-63999 IN AN
40 REM EXEC FILE 'CROSS-REF' WHICH MAY
50 REM BE EXECUTED DIRECTLY ON A PROGRAM
60 REM IN MEMORY TO GIVE A CROSS-REF
70 REM LIST OF THE PROGRAM'S VARIABLES
80 REM EXTENDED BY N.LOMAS FROM PROGRAM BY E.MCGEOUGH, P.
  C. JAN 81
90 REM LINES 63955-63999 ARE LOADED ON TOP
100 REM OF THE PROGRAM AND RUN TO EXTRACT
110 REM ALL THE REFERENCES AND WRITE THEM
120 REM TO ONE OR MORE OSIC FILES AND
130 REM THE CROSS-REFERENCE LIST.
140 REM EACH DISC FILE CONTAINS UP TO 512
150 REM REFERENCES PRECEDED BY TWO NUMBERS.
160 REM THE FIRST NUMBER IS THE NUMBER OF
170 REM REFERENCES ON THE FILE.
210 REM THE SECOND NUMBER IS NON-ZERO IF
220 REM THERE IS ANOTHER FILE TO FOLLOW.
230 REM "CROSS-REF"

```

```

250 DS = CHR$(4)
260 PRINT DS;"OPEN "INF$
270 PRINT DS;"DELETE "INF$
280 PRINT DS;"OPEN "INF$
290 PRINT DS;"WRITE "INF$
300 LIST 63955
310 PRINT "RUN63955"
320 PRINT "NEW"
330 LIST 1000,1020
340 LIST 1040,1070
350 LIST 1100,1170
360 LIST 1210,1240
370 LIST 1270
380 LIST 1310,1450
390 LIST 1470,1480
410 LIST 1510
420 LIST 1530,1550
440 LIST 1590
450 LIST 1640,1660
460 LIST 1710,1720
470 PRINT "RUN"
480 PRINT DS;"CLOSE "INF$
490 END
1000 DS = CHR$(43);IS = CHR$(9);YA = 1;PD$ = " " ;M = 7
60 DIM T$(512),U$(512),P$(512)
1010 OP$ = "OPEN XREF LIST "IRD$ = "READ XREF LIST "MRS = "
WRITE XREF LIST "ICL$ = "CLOSE XREF LIST "
1020 PRINT DS;OP$;YA; "D1"
1030 REM INPUT THE STRING ARRAY AND
1040 REM CONSTRUCT A WATCHING ARRAY
1050 REM OF POINTERS
1060 PRINT DS;RD$;YA; INPUT X; INPUT YB: FOR C = 1 TO X: INPUT
T$(C);PP$ = "D1"; NEXT
1070 T$(X + 1) = CHR$(255): PRINT DS;CL$;YA
1080 REM PERFORM A SHELL SORT
1090 REM OF THE ARRAY OF POINTERS
1100 Y = X;M = Y; PRINT "SORTING --- WAIT"
1110 M6 = INT (M6 / 2): IF M6 = 0 THEN I210
1120 K6 = Y - M6;J6 = 1
1130 I210
1140 L6 = I6 # M6: IF T$(PP$(L6)) < T$(PP$(I6)) THEN I160
1150 PP = PP$(L6);PP$(L6) = PP$(I6);PP$(I6) = PP: I6 = I6 - M6: IF
I6 > 1 THEN I140
1160 J6 = J6 + 1: IF J6 > M6 THEN I110
1170 GOTO I130
1180 REM END OF SORT
1190 REM WRITE THE SORTED FILE BACK
1200 REM TO THE DISK
1210 PRINT DS;OP$;YA; PRINT DS;MRS;YA
1220 PRINT X: PRINT YB: FOR C = 1 TO X: PRINT T$(PP$(C)): NEXT
1230 FOR C = 1 TO X:T$(C) = "": NEXT
1240 PRINT DS;CL$;YA; IF YB < > 0 THEN YA = YA + 1: GOTO I
020
1250 REM IF THERE IS ONLY ONE FILE
1260 REM GO DIRECTLY TO PRINT
1270 IF YA = 1 THEN I470
1280 REM READ THE FILES IN PAIRS
1290 REM AND MERGE THEM BACK
1300 REM ON TO THE DISC
1310 FOR YC = 1 TO YA - 1: FOR YD = YC + 1 TO YA: PRINT "ME
RCING FILE "YC;" AND "YD:"
1320 PRINT DS;OP$;YC: PRINT DS;RD$;YC
1330 INPUT XA: INPUT YB: FOR C = 1 TO XA: INPUT T$(C): NEXT
T$(XA + 1) = CHR$(255)
1340 PRINT DS;ICL$;YC
1350 PRINT DS;OP$;YD: PRINT DS;RD$;YD
1360 INPUT XB: INPUT YE: FOR C = 1 TO XB: INPUT U$(C): NEXT
U$(XB + 1) = CHR$(255)
1370 PRINT DS;ICL$;YD: PRINT DS;OP$;YC: PRINT DS;MRS;YC: PRINT
XA: PRINT YB
1380 XT = 1;XU = 1: FOR XE = 1 TO XA
1390 IF T$(XT) > U$(XU) THEN PRINT U$(XU);U$(XU) = "":XU =
XU + 1: GOTO I410
1400 PRINT T$(XT);T$(XT) = "":XT = XT + 1
1410 NEXT : PRINT DS;CL$;YC: PRINT DS;OP$;YD: PRINT DS;MRS;
YD: PRINT "MERGED"
1420 FOR C = 1 TO XB
1430 IF T$(XU) > U$(XU) THEN PRINT U$(XU);U$(XU) = "":XU =
XU + 1: GOTO I450
1440 PRINT T$(XT);T$(XT) = "":XT = XT + 1
1450 NEXT : PRINT DS;CL$;YD: NEXT : NEXT
1460 REM READ A FILE
1470 T$(C) = PD$: FOR YC = 1 TO YA: PRINT DS;OP$;YC: PRINT D
$;RD$;YC
1480 INPUT X: INPUT YB: FOR C = 1 TO X: INPUT T$(C): NEXT
1490 REM PRINT THE FILE AND RETURN
1500 REM FOR THE NEXT
1510 COSUB I590: PRINT DS;CL$;YC: NEXT
1520 REM DELETE ALL WORK FILES AND END
1530 FOR YC = 1 TO YA: PRINT DS;"DELETE XREF LIST "YC: NEXT
1540 END
1550 PRINT DS;"PR$:" PRINT IS;"N$:" PRINT IS;"B$:" RETURN
1560 REM PRINT FILE
1570 REM OPEN PRINTER AND SPACE ALONG
1580 REM LINE IF NOT FIRST FILE
1590 COSUB I590: IF MH < > 0 THEN PRINT SPC$(MH);
1600 REM IF THE NEXT VARIABLE DIFFERS FROM THE LAST
1610 REM START A NEW LINE.
1620 REM IF NOT APPEND LINE NUMBER
1630 REM UNLESS PRINT LINE IS FULL.
1640 FOR C = 1 TO X: IF LEFT$(T$(C - 1),4) < > LEFT$(T
$(C),4) THEN PRINT "": PRINT T$(C);MH = 10: GOTO I710
1650 IF MH > = 4 THEN PRINT "": PRINT PD$;MH = 4
1660 PRINT RIGHT$(T$(C),6);MH = MH + 6
1670 REM AT END OF FILE SET T$(0) TO
1680 REM THE LAST REFERENCE PRINTED
1690 REM TO COMPARE WITH 1ST REF ON NEXT FILE.
1700 REM EXECUTE REVERSE LF AND TERMINATE LINE
1710 NEXT T$(C) = T$(X): PRINT CHR$(27) + CHR$(10)
1720 PRINT DS;"PR$:" RETURN
63955 TEXT : HOME
63956 PRINT "VARIABLE LISTER"
63957 DS = CHR$(43)
63958 PRINT DS;"SAVE IN CASE OF ACCIDENTS,D1"
63959 X = 0;Y = 1;LL = 63955: REM HIGHEST LINE
63960 PD$ = " "
63961 DIM T$(512)
63962 REM FIND FIRST LINE
63963 NL = 2049
63964 P = 2049
63965 REM RETURN HERE FOR NEXT LINE
63966 NL = PEEK (P) + PEEK (P + 1) + 256
63967 IF NL = 0 THEN 63997
63968 P = P + 2
63969 LN = PEEK (P) + PEEK (P + 1) + 256:P = P + 1
63970 IF LN > LL THEN 63997
63971 LAB$ = ""
63972 COSUB 63980: REM GET NEXT ALPHA
63973 LAB$ = LAB$ + CHR$(NEXT)
63974 COSUB 63988: REM GET NEXT CHAR
63975 IF CH > 64 AND CH < 91 THEN 63973
63976 IF CH > 47 AND CH < 58 THEN 63973
63977 IF CH = 36 OR CH = 37 THEN 63973
63978 COSUB 63993
63979 GOTO 63971
63980 COSUB 63988
63981 IF CH = 34 THEN COSUB 63984: GOTO 63980
63982 IF CH < 65 OR CH > 90 THEN 63980
63983 RETURN
63984 COSUB 63988
63985 IF CH < > 34 THEN 63984
63986 RETURN
63987 REM GET NEXT CHAR
63988 P = P + 1
63989 IF P = NL THEN POP : POP : GOTO 63965
63990 CH = PEEK (P); IF CH = 178 THEN P = NL: POP : POP: GOTO
63965
63991 RETURN
63992 REM STORE LABEL
63993 PRINT LN;" "LAB$
63994 IF X = 512 THEN A = 1: COSUB 63998
63995 IF LEN (LAB$) > 4 THEN LAB$ = LEFT$(LAB$,3) + RIGHT$(
LAB$,1)
63996 X = X + 1;LN$ = STR$(LN);T$(X) = LEFT$(LAB$,PD$,
RIGHT$(PD$,4) + LAB$: RETURN
63997 YA = 0: COSUB 63988: END
63998 PRINT DS;"OPEN XREF LIST "Y;"D1" PRINT DS;"WRITE X
REF LIST "Y
63999 PRINT X: PRINT YA: FOR C = 1 TO X: PRINT T$(C);T$(C) =
"": NEXT : PRINT DS;"CLOSE XREF LIST "Y;"Y = Y + 1;X =
0: RETURN

```

IF YOU have followed my advice from the previous micromouse pages and now have a movable chassis, you are about to discover the two basic laws of dynamics:

- When a moving object meets an immovable object, the immovable object is knocked out of the way.
- Every static object exerts an equal but not opposite attraction to any nearby moving object.

The underlying principle of the first law is that a robot must detect an object sufficiently far away from it to be able to stop. One mouse, based on ordinary motors, had the problem that — although it could detect objects at a distance — when the wheels were stopped the mouse kept on sliding until it hit a wall. On one memorable occasion it burst out of the side of the maze and leapt into space — it was caught just in time.

Remember, the base of the maze is chipboard painted in a smooth, matt-black paint. I believe slightly spongy wheels — such as the model aircraft wheels I used — are essential.

It is also worth noting that the walls of the maze are designed only to withstand a force of one Newton — the weight of a medium-sized apple, I am told. Another mouse, based on stepper motors, had trouble with deceleration. Stepper motors

by Nick Smith

need to be accelerated if high speed is to be achieved but this means, of course, they need to be decelerated to stop. It can mean that sensors need to be able to detect a wall in front from a considerable distance.

The mouse from Finland took about a metre to stop from its top speed. Its sensors could detect a wall at a distance of about 4in. Before you fall out of your chair in hysterical laughter, I would like to point out just how clever their software was. Like all good mice it built-up a bit map of the maze. Unlike any other mouse, however, it had three possible states for each wall: wall present, wall not present, not known.

When running in a straight line, the software checked ahead to find the nearest known wall or unknown position. It then continuously calculated its speed on the basis that it must be able to stop if there was a wall at that point. The first time it went along a passage it went relatively slowly, accelerating and decelerating in little bursts from square to square.

The second time along a passage, it accelerated smoothly to a much higher speed until, half way along, and then it decelerated smoothly to the end. When it became confused, however, it managed to demolish several walls before it stopped.

The underlying principle of the second law is that however hard you try, your mouse will not travel in a straight line. It is much better to accept this and start planning on what your mouse is going to

Dynamics laws create control 'nightmare'

do as it is magically attracted towards a side wall, rather than to try harder and harder to build a mouse that will go straight. A mouse could travel several 100ft. not to mention going round many 90° corners during its 15 minutes in the maze.

After the July trial last year, the competition organiser John Billingsley was so concerned about peoples lack of understanding of control theory that he sent the following advice to all competitors:

The most important thing to bear in mind is that what the controller does not know about, it cannot control. When guiding a mouse along a straight run, everybody thinks about the mouse's displacement from the centre line, but at least as important is the angle at which the mouse is pointing. For a vehicle with a steering wheel, running at constant speed, the behaviour can be described by two state equations:

1. Rate of change of displacement is proportional to angle — roughly.
2. Rate of change of angle is proportional to steering.

For stability, the feedback signal which controls the steering must contain information of both displacement and angle. The simplest way to achieve this is by mounting the wall-sensor forward of the unsteered axle — the further forward, the more the signal will depend on the angle. Since, in most systems, this signal will be on-off, its use to control steering angle would result in the front wheel(s) snapping to-and-fro. If instead it is used to control the rate-of-turn of the steering wheel, there is a third state equation: 3. Rate of change of steering is proportional to input.

Thus the feedback signal must also reflect the steering angle. This can be achieved by mounting the sensor on a forward boom which rotates with the steering — not an easy thing to fit within the confines of a maze, however.

The mice which entered the Portsmouth heat were not based on a car, but on a wheelchair. The two main wheels, one each side, are driven independently. To prevent toppling, other wheels are fitted but these merely act as castors. For steering, one wheel is driven forwards while the other is driven backwards — or less strongly, or not at all. This scheme is mechanically much simpler, but it can become a controller's nightmare. The state equations now become:

1. Rate of change of displacement is proportional to angle — rather more roughly.
2. Rate of change of angle is proportional to left-motor-speed minus right-motor-speed.
3. Rate of change of left-motor-speed is proportional to applied left drive minus motor damping effect times left speed.
4. Rate of change of right motor speed is proportional to applied right drive minus motor damping times right speed.

Having built what John Billingsley describes as a controller's nightmare, I was not entranced by the idea of writing the software to solve four simultaneous differential equations. How I eventually solved the steering problem will be the subject of a future article.

It does not matter how good your logic and software are if your sensors are not

gathering the necessary information and transmitting it correctly to the controller. My own mouse was based entirely on mechanical sensors because I did not have the electronic knowledge to do anything else. For the benefit of the more advanced constructor, I have obtained information and suggested circuits for using Ultra Sonics which should be ideal for long-range sensing.

I have, however, failed to glean any information about using infra-red devices for sensors. The Plessey team — whose mouse used infra-red rays — are not talking. Anyway, I understand their circuit included purpose-built chips not available to the general public. If anyone can supply me with details of using infra-red devices, especially for measuring distance, please write.

The code to generate the sequence of bit patterns for my stepper motors was incorrect. The third and fourth lines were interchanged. If, when you do a shift, a 1 drops off one end, you add a 1 to the other end to maintain the bit pattern. So, if a zero is shifted out, you skip the addition.

Summer heats

FOR THOSE trying to plan your summer holidays you could go to:

Paris May 4-9 for Micro-Expo 81, heat

Holland June, heat

London July 29-31 for the Online Exhibition, heat

Paris September 7-10 for the Euro-micro Symposium, finals

The Paris heat and finals are at the Palais De La Découverte. There will also be a number of weekend trials held there during the summer.

Entry forms

FOR DETAILED information about the competition and entry forms please contact Dr John Billingsley, Portsmouth Polytechnic, Department of Electrical and Electronic Engineering, Anglesea Building, Anglesea Road, Portsmouth, PO1 3DJ.

John Billingsley is about to reduce his regular mailing list to those people who have sent in completed entry forms. So, if you have obtained details and have not yet sent in your entry form, do it now.

There have been enquiries from just about every European country you can think of and an entry from Japan. There have even been two enquiries from Russia. I would guess the most common language between the contestants is likely to be Z-80 machine code despite the fact that the RCA 1802 is a much more useful micro chip. □

User Groups is a region-by-region list of micro clubs in Britain. If a new club has been formed, send us the details and we will include them in the next available issue.

AVON

BAUD, Bristol Apple Users and Dabblers
Geoff Smythe
Datalink Microcomputer Systems Ltd
10 Waring House
Redcliffe Hill
Bristol BS1 6TB.
Tel: 0272 213427.

Bristol Computing Club
Leo Wallis
6 Kilbernie Road
Bridge Farm Estate
Bristol BS14 0HY.
Tel: 0272 832453.

Brunel Computer Club
S W Rabone
18 Castle Road
Worle
Weston-Super-Mare
Avon BS22 6JW
Tel: 0934 513068

BEDFORDSHIRE

U.K. Intel MDS Users' Group
Lewis Hand
29 Chaucer Road
Bedford.
Tel: 0234 41685.
6502 Users' Club
Joe Manifold
16 Bun Yam Close
Pirton, near Hitchin
Hertfordshire.
Tel: 0462 18522.

BERKSHIRE

Commodore Pet User Club
M Gulliford
818 Leigh Road
Slough Industrial Estate
Slough
Berkshire.
Tel: 0753 74111.

BUCKINGHAMSHIRE

Apple Users' Group
S F Proffitt
The Granary
Hill Farm Road
Marlow Bottom
Buckinghamshire.
Tel: Marlow 73074
01-750 7298, day.

National TRS-80 Users' Group
Brian Pain
40a High Street
Stony Stratford
Milton Keynes
Buckinghamshire.
Tel: 0908 566660.
International Nascom Microcomputer Club
The Secretary
c/o Oakfield Corner
Sycamore Road
Amersham
Buckinghamshire.
HP6 6SU.

CAMBRIDGESHIRE

Peterborough Computer Club
Trevor Marchant.
Tel: 0733 76681.

CHESHIRE

North-west Computer Club
John Lightfoot
135 Ashton Drive
Frodsham, Warrington
Cheshire WA6 7PU.
Tel: 0928 31519.

CLEVELAND

Cleveland Microcomputer Club
J H Telford
13 Weston Crescent
Norton, Cleveland.
Tel: 0642 550061.

DEVON

Acorn Atom User Group
T G Merdeith
Sheerwater
Yealm View Road
Newton Ferrers
South Devon.

Exeter and District Amateur Computer Club
Doug Bates
2 Station Road
Pinhoe
Exeter.
Tel: 0392 69844.

Plymouth and District Amateur Computer Club
Keith E Gould
Willoby House
Meavy Lane
Yelverton
Devon PL20 6AL.
Tel: 082285 2575.

DORSET

Tangerine Users' Group International
Microtan 65 Users'
R B Green
16 Iddesleigh Road
Charminster
Bournemouth
Dorset BH3 7JR.

DURHAM

North-east Pet Users' Group
Jim Cocallis
20 Worcester Road
Newton Hall Estate
Durham.
Tel: 0385 67045.

EAST ANGLIA

Anglia Computer User Group
Jan Rejzl
128 Templemere
Sprouton Road
Norwich NR3 4EQ.

ESSEX

London and South-east Sharp MZ-80K User Group
Joe Seet
16 Elmhurst Drive
Hornchurch
Essex RM11 1PE.
Tel: 04024 42905.
TRS-80 User Group
Michael Dean
22 Roughtons
Galleywood
Chelmsford
Tel: 0245 76127.

UK101 User Group
Adrian Waters, 117 Haynes Rd
Hornchurch
Essex.
Tel: 494 0490.

Springfield Computer Club
Steve Cousins
1 Aldeburgh Way
Springfield, Chelmsford
Essex CM1 5PB.
Tel: 0245 50155.

GLOUCESTERSHIRE

Cheltenham Amateur Computer Club

M Pullin

45 Merestones Drive
The Park
Cheltenham GL50 2SU.
Tel: 0242 25617.

990 User Group
Chris Cadogan
21 Thistle Downs
Northway Farm, Tewkesbury.
Tel: 0684 293821, Ext. 310.

HAMPSHIRE

Independent Pet Users' Group
G A Parkin
Robert May's School
West Street, Odiham.
Tel: 025 671 2700.

Southampton Amateur Computer Club
P G Dorey
Dept. of Physiology
The University
Southampton SO9 3TU
or Andy Low.
Tel: (0703) 555605, Ext. 34.

UCSD Pascal User Group
John Ash
Dicoll Data Systems Ltd
Bond Close
Kingsland Estate, Basingstoke.
Hampshire RG24 0QB.

HERTFORDSHIRE

Apple/ITT 2020 Users' Group
John A Sharp
20 The Glebe
Garston
Watford
Hertfordshire WD2 6LR.
Tel: Garston 75093.

The Harrow Computer Group
N P Butcher
16 St Peter's Close
Bushey Heath
Watford.
Hertfordshire WD2 3LG.
Tel: 950 7068.

Harpenden Microcomputer Group
David M James
5 Ox Lane
Harpenden
Hertfordshire.
Tel: 05827 5366, evenings.

INTERNATIONAL

International Association of Cromemco Users
PO Box 17658
Irvine, California 92713 U.S.A.
Tel: 714 955 0432.

ISLE OF WIGHT

TRS-80 Users' Club
Mike Collins
3 Altofts Gardens
Ventnor
Isle of Wight.

KENT

Independent Pet Users' Group South-east Region
164 Chesterfield Drive
Sevenoaks
Kent TN13 2EH.
Tel: Sevenoaks (0732) 53530.

Gillingham User Group
A Aylward
194 Balmoral Road
Gillingham.
Tel: 0634 56830.

Medway Amateur Computer and Robotics Organisation
Mrs C Webster

13 Ladywood Road
Cuxton, Rochester
Kent.

Tel: 0634 78517.
North Kent Amateur Computer Club
B J Biddles
3 Acer Road
Biggin Hill
Kent TN16 3SP.
Tel: 29 71742.

LANCASHIRE

Amateur Computer Club 2650 Library
Roger A Munt
51 Beechwood Drive
Feniscowles, Blackburn
Lancashire.
Tel: 0254 22341.

Chorley Computer Club
Chris Hicks
131 Market Street
Chorley
Lancashire.
Tel: Chorley 78376 or 71875.

North Lancashire User Group
Denise Green
550 Midgeland Road
Blackpool.
Tel: 0253 692261.

North-west Group Amateur Computer Club
Ken Horton
50 Lymfield Drive
Worsley.
Tel: 061 228 6333, Ext. 372.

TRS-80 Users' Group
Melvyn D F Franklin
40 Cowlees
Westhoughton, Bolton
Lancashire.
Tel: 0942 812843.
West Lancashire Pet Users' Club
D W Jowett
197 Victoria Road East
Thornton
Blackpool FY5 3ST.
Tel: 0253 869108.

LEICESTERSHIRE

Leicestershire Personal Computer Club
Jill Olorenshaw
c/o Arden Data Processing
Municipal Buildings
Charles Street
Leicester.
Tel: 0533 22255.

LINCOLNSHIRE

Lincolnshire Microprocessor Society
Eric Booth
Bishop Grossetest College
Newport, Lincoln.
Tel: 0522 27347.

LONDON

Comp80 - Scientific Computer Users' Group
P L Roberts
50 Cromwell Road
Wimbledon
London SW19 8LZ.
Tel: 01-540 3713.

Computerclub
Roger R Frampton
42 Great Windmill Street
London W1V 7PA
CP/M Users' Group U.K.
D Powys-Lybbe

(continued on next page)

(continued from previous page)

11 Sun Street
London EC2M 2PS.
Tel: 01-247 0691.

Medical Micro Users' Group
Patrick Dixon
c/o Medicom
14 Broadway
London W13.
Tel: 01-579 5845.

National TRS-80 Users' Group
J S Wellsman
292 Caledonian Road
London N1.
Tel: 01-607 0157

National ZX-80 Users' Club
Tim Hartnell
44-46 Earls Court Road
London W8 6EJ

North London Hobby Computer Club
Robin Bradbeer
Dept. of Electronic and
Communications Engineering
Polytechnic of North London
Holloway Road
London N7.
Tel: 01-607 2789.

Southgate Computer Club
Panos Koumi
33 Chandos Avenue
London N14

or Alan Tootill on
01-360 7014 (home) or
01-882 6111 Ext 2281 (work)

South-east London Microcomputer Club
Peter Phillips

61 Craigerne Road
London SE3.
Tel: 01-853 5829.

MK-14 User Club
Geoff Phillips
8 Poolsford Road
NW9 6HP.
Tel: 01-200 6209
or 01-207 2000, Ext. 233.

OSI U.K. User Group
Richard Elen
12 Bennerley Road
London SW11 6DS.
Pet Users' Club
Commodore Systems Division
360 Euston Road
NW1 3BL.
Tel: 01-388 5702.

Pet Users' Education Group
Dr Chris Smith
Dept. Physiology
Queen Elizabeth College
Campden Hill Road
W8 7AH.
Tel: 01-937 5411, Ext. 429.

MANCHESTER
Manchester Atom Users' Group
Clement M Rutter
3 Leopold Avenue
Withington
Manchester
M20 8JG.
Tel: 061 434 3092
Manchester Computer Club
David Wade
28 Hazel Road
Altrincham
Cheshire
WA14 15L.
Tel: 061 941 2486.

MERSEYSIDE
Level 1 User Group
N Rushton
123 Roughwood Drive
Northwood, Kirkby
Merseyside L33 9UG.
U.K. Pilot User Group
Alec Wood
Wirral Grammar School
Cross Lane

Bebington
Wirral
L63 3AQ.

MIDDLESEX
Independent Pet Users' Group
Geoff Squibb
108 Teddington Park Road
Teddington
Middlesex.
Tel: 01-977 2346.

Richmond Computer Club
R A Forster
18a The Barons
St Margaret's
Twickenham
Middlesex.
Tel: 01-892 1873.
West London Personal Computer Club
G J Brain
81 Rydal Crescent
Perivale
Middlesex.
Tel: 01-997 8986.

NORFOLK
East Anglia Computer User Group
Under East Anglia

NORTHAMPTON
Personal Computer Users' Club
J R Jackson
Mereway Upper School
Mereway
Northampton NN4 9BU.
Tel: 0604 63616.

NOTTINGHAMSHIRE
Independent TRS-80 User Group
Mike Costello
17 Langbank Avenue
Rise Park
Nottingham NG5 5BU.
Nottingham Microcomputer Club
P McQuoney
28 Seaford Avenue
Wollaton
Nottingham.
Tel: 0602 751742.
UK Apple Users' Group
5b The Poultry
Nottingham NG1 2HW
Tel: 0602 583254

OXFORDSHIRE
Oxford University Microcomputer Society
Phillip Taylor
St John's College
Oxford.
Tel: 0865 47671.
Oxfordshire Microcomputer Club
S C Bird
139 The Moors
Kidlington
Oxford OX5 2AF.
Tel: 08675 6703.
Research Machines Users' Group
Tony Crowle
134 Howard Street
Oxford.

SCOTLAND
Central Scotland Computer Club
James G Lyon
78 Slamannan Road
Falkirk FK1 4NF.
Tel: Falkirk (0324) 22430.
The Grampian Amateur Computer Society
M Basil
Orton Cottage
Burnside
Lumphanan
Kincardineshire
Grampian Region.

Tel: 033 983 284.
Scottish Amateur Computer Society
Alistair Macpherson
6 Curriehill
Castle Drive
Edinburgh 14.
Tel: 031 449 6658.
Ithaca Audio S-100 User Group
Strathclyde Computer Club
Dave Weaver 16 Etive Place
Condorrat
Cumberland
Near Glasgow G67 4JF.
Tel: 023 67 36570 or
1 Barraclough
c/o S T V Cowcaddens
Glasgow.
SOMERSET
Ohio Scientific U.K. User Group
Tom Graves
19a West End
Street
Somerset BA16 0LQ.
Tel: 0458 45359.

STAFFORDSHIRE
Independent Pet Users' Group IPUG
57 Clough Hall Road
Kidsgrove
Stoke-on-Trent
Staffordshire.
The Amateur Computer Club of North Staffordshire
1 Roll 16 Hill Street
Hednesford
Staffs WS12 5DJ.
Tel: 05438 4363
or 0785 3251 Ext. 441 work.

SURREY
Forth Interest Group U.K.
H Dobson
c/o 38 Worsley Road
Frimley, Camberley
Surrey GU16 5AU.
Tel: Deepcut (02516) 6254.
ZX-80 Users' Club
David Blagden
PO Box 159
Kingston-Upon-Thames
Surrey KT2 5YQ.

SUSSEX
Crawley Computer Club
John Fieldhouse
18 Seaford Road
Crawley
West Sussex.
Tel: 0293 543509.
Mid-Sussex Microcomputing Club
Bernard Langton
228 St Leonard's Road
Horsham
West Sussex RH13 6AU.
Tel: 0403 61156.
Southern Users' of Pet Association SUPA
Howard W Pilgrim
42 Compton Road
Brighton
Sussex BN1 5AN.
Tel: 0273 561982.

TYNE AND WEAR
Newcastle Personal Computer Society
John Bone 2 Claremont Place
Gateshead, Tyne and Wear
Tel: 770036 home, or
0632 781412, Ext. 236 work.
TRS-80 User Group
Dr S Tetlow 3 Highbury Close
Springwell, Gateshead
NE9 7PU
Washington 462532

WALES
Gwent Amateur Computer Club
Ian Hazell 50 Ringwood Hill
Newport, Gwent NPT 9EB.
Tel: 0633 277711.
National TI-58/59 Club
R M Murphy
Dept. of Electrical Engineering
University College Swansea
Swansea, South Wales.

WEST MIDLANDS
Central Program Exchange
Mrs J Brown
Dept. of Computing and
Mathematical Sciences
The Polytechnic
Wulfruna Street
Wolverhampton WV1 1LY.
Tel: 0902 27371, Ext. 56.

Amateur Computer Club
John Tracey 100 Booth Close
Brierley Hill
West Midlands DY6 8SP.
Tel: 0384 70097.

Birmingham 7/66 User Group
Sue Dunn
Newbear Computing Store
First Floor Offices, Tivoli Centre
Coventry Road, Birmingham B26.
Tel: 021 707 7170.

Midland Amateur Computer Club
Roy Diamond
27 Loweswater Road
Coventry CV3 2HJ
Tel: 0203 454061.
West Midlands RML User Group
Peter Smith BECC
Campmill Centre, Stratford Road
Birmingham B11 1AR.

WORCESTERSHIRE
Minicomputer Users In Secondary Education - MUSE
R Trigger 48 Chadcote Way
Catshill, Bromsgrove
Worcestershire.
Worcester and District Computer Club
D J Stanton 55 Vauxhall Street
Rainbow Hill, Worcester WR3 8PA.
Tel: 0905 22704.

YORKSHIRE
West Yorkshire Microcomputer Group
P R Clark Suite 204, Crown House
Armley Road, Leeds LS12 2EJ.
Tel: 0532 450667.
Leeds and District Branch of the British Computer Society
Dave J Sheppard
20 Green Lane Close, Overton
Near Wakefield WF4 4SE.
Tel: 0924 270419.
Darlington Computing Club
L Boxell 8 Vane Terrace
Darlington DL3 7AT.
Tel: 0325 67766.
Penine and District Computer Club
Douglas R Bryant 26 Mill Hey
Haworth, West Yorkshire
BD22 8NA.
Tel: 0535 43007.

South Yorkshire Personal Computing Group
S P Gray
11 The Meadow
Sheffield S17 3EB.
Tel: 0742 351440.

Sharp PC-1211 Users' Club
Jonathan Dakeyne 281 Lidgett Lane
Leeds LS17 6PD.

York Computer Club
S Wilson 1 Grange Close
Skelton, York YO3 6YR.
Tel: York 470464 after 6pm.

Machine-code programming for the Nascom 1 and 2

By G R Wilson. Published by Interface Components Limited, Oakfield Corner, Sycamore Road, Amersham, Buckinghamshire, HP6 6SU. Telephone 02403 22307. 125 A4 pages paperback, available from the publisher. Price £4.50 plus 50p postage.

THIS BOOK is intended for the Nascom programmer with little or no previous experience of machine-code programming. It covers the necessary ground to start the reader programming confidently, but lacks the extra features which would make it especially useful.

Following an introduction to number systems and to computer concepts, the text describes the detailed function of the most important Z-80 instructions. They include the register-register and memory-register-memory move instructions, conditional and unconditional branches, arithmetic and logical operations and shifts, and simple input-output. The instructions are extensively illustrated by example program sections, with associated descriptive text, flowcharts and diagrams.

Appendices

There are five appendices which describe the CPU register sets and memory maps for Nascom 1 and Nascom 2, give a routine for displaying CPU registers, explain the attachment of simple I/O devices; describe the method of entering and executing a program under Nas-Sys; and, finally, provide a list of Nasbug routines equivalent to the Nas-Sys routines used in the text.

The contents are perfectly adequate for an introduction to Nascom machine-code programming, but the provision of a few extras could have easily lifted the text into a higher class altogether. A full list of Z-80 operation codes, mnemonics, timings, and a symbolic description of each instruction would only take a few extra pages but would make this a useful reference text once the reader has gained proficiency. A simple index would help.

Most valuable, the inclusion of 12 or so useful subroutines would save a great deal of wasted programming effort as many readers reinvent standard algorithms. Candidates for inclusion might be integer multiplication and division — for eight- and 16-bit values — simple floating-point, one or two sorts, a hashing routine, a search, a random number generator, a simple storage manager, and routines to convert printable characters to binary numbers and *vice versa*, for integers, decimals and floating-point. Such subroutines would serve the additional functions of providing substantial examples of good programming techniques.

With the additions mentioned, this would be an exceptionally good text for readers who want to teach themselves machine-code programming with a Nascom. It should be stressed, however, that there are some disadvantages to learning programming by starting at the machine-code level.

Real danger

There is a danger that the detail of registers, bits and instruction codes will obscure the real nature of the problem being solved, and that the newcomer to programming will develop a preoccupation with implementation details and efficiency which will make it harder to solve the larger-scale, complex, interesting problems of computing.

There is an increasingly widespread view among professional programmers that assembly or machine-code programming should be reserved for the few small sections of programs where the access to machine instructions is essential, and that high-level languages should be used elsewhere.

The pressures on amateurs are, of course, different and they have different interests, but anyone who plans a career as a programmer might do well to remember the professionals' increasing preference for higher-level languages.

Conclusions

- A valuable book, providing a clear and accurate introduction to Z-80 machine-code programming and the Nascom.
- With a few additions this

book could be exceptional; with its present contents it is still a thoroughly satisfactory book and good value for money.

Martyn Thomas

Business information processing with Basic

George Struble. Published by Addison Wesley Publishing Company. 354 pages hardback. ISBN 0 201 07640 3.

FIVE TO 10 years ago it seemed as if everyone able to program was writing books on IBM 360/370 assembler. One text stood out as a standard against which all the others were judged and found wanting; one text had clearly been written by someone who had considerable experience of teaching the subject successfully.

That book was written by George Struble, and if any reader is looking for a textbook to serve as a tutorial text and reference book on IBM assembly language, BAL, Struble's book can be thoroughly recommended.

Nowadays, it seems as if everyone who can both program and spell is rushing to publish a book on programming in Basic, and once again George Struble has rushed to the rescue with a thoroughly-professional book — one surely destined to become a classic and a standard for judging future texts.

Struble's book is intended for students who wish to learn how to use a computer to solve business data-processing problems. It is equally suitable for use in a taught course and as a self-study text. No previous knowledge of computers, data processing or mathematics is required.

The book starts with an introduction to computer applications in businesses, and to the structure, organisation and use of a computer. Programming is introduced as a logical activity which should lead to a clear and correct statement of the actions which have to be performed.

The ideas of structured programming are introduced from the very beginning and are carried through the text, so the unstructured nature of the Basic language is not allowed to lead the novice programmer into bad habits which will have to be lost when a more power-

ful language such as Pascal is learned.

Struble explains in his preface that he prefers Basic to Cobol or RPG for an introductory business data processing course because it lends itself to this well-structured, procedural approach to programming.

He certainly carries conviction — the example programs are very good examples of clear, efficient, correct programs. The examples are noteworthy for other reasons, too. The use of REM is exemplary and the listings seem to have been reproduced from clear computer output, removing the dangers of errors introduced in the typesetting process.

Each of the chapters of the book ends with a summary of the main ideas and with a number of "questions for imagination and review". The questions are well-chosen and, best of all, the odd-numbered questions have answers given at the end of the book. There is a glossary and a good index.

Since it is a book for the real world of business applications, the whole text has a very practical air. Much emphasis is laid on file processing and a chapter is devoted to testing and debugging. There is also a chapter on systems analysis — the process of studying the way something is done in a business and deciding how it can best be implemented as a computer system.

The particular dialect of Basic used in all the examples is DEC-10 Basic, but not all the features of this are used, and, in any case, the use of pseudo-code as a design tool makes it easy to translate into the local dialect of Basic the reader has available.

According to the preface to the book, there are a number of workbooks available giving the example programs in various other dialects, but none of these were provided for review.

Conclusions

- An excellent book, thoroughly recommended to anyone who is serious about learning to program in Basic, particularly for business applications.
- It is destined to become a yardstick for measuring the comparative success of other authors' work. Martyn Thomas



TRS-80

Turn yours into an
INDUSTRIAL CONTROLLER
with an IF-100 from

E. & L. Instruments Ltd.

Whitegate Ind. Estate,
Wrexham, Clwyd LL13 8UG
Tel: 0978-263030

ALSO AVAILABLE FULL RANGE OF TEACHING
EQUIPMENT IN MICROELECTRONICS

• Circle No. 179

TOP QUALITY FLOPPIES Verbatim

Ex: Single Side Single Density Diskettes

	Unit Price	Box Price inc. VAT
8"	£2.27	£27.37
5 1/4"	£1.79	£21.90

Always Quote Your Machine Type When Ordering

- Many other Types Available
- We Can Quote for Your Machine
- Quantity Discount For 50 +

Please Give Us A Ring



48 HEDLEY STREET, MAIDSTONE, KENT ME14 5AD
Tel. Maidstone 679 595 MAIL ORDER ONLY

• Circle No. 180



DSD Digital Microsystems

OVERPRICED COMPUTERS INADEQUATE PERSONAL MICROS?

Modata supply Dealers and OEMs with
Digital Microsystems competitively priced
Single and Multi-User computers which
include Reliable Floppy and Hard Disk
storage.

ie. DSC-2: Z80 at 4MHz + 64Kb +
2 x SSDD 8" Floppies for IMb + CP/M
- £3525 E.U.

**WHY NOT FINDOUT MORE?
0892 41555**

Modata Ltd. 30 St. Johns Road,
Tunbridge Wells, Kent TN4 9NT

• Circle No. 181

apple II in sussex

oval computer systems

Elm Park, Ferring, Worthing, West Sussex tel: 0903-44831
198 Church Road, Hove, East Sussex tel: 0273-558299

• Circle No. 182

How to translate 6502 to Z-80 assembly language

TO KEEP things to a manageable size, the program is intended to take a general 6502 listing, and translate it to a general Z-80 listing. Thus, machine-specific sections are only translated as assembly code — they are not altered to suit the architecture of the target computer. For example, a Pet program may write directly to that computer's memory-mapped display — the translation would not automatically

by David Peckett

write to, say, the TRS-80 display area. Similarly, you will have to make your own decision about where to put the stack.

In this first article, I shall describe some of the theory behind the program; in part 2, I shall give its listing. The second part will also go into some of the practical aspects of using the translation program. I have to assume all the way through that you are familiar, to some extent, with the two micros' assembly languages — if you need more details, may I refer you to my recent series on the subject?

First of all, though, what is the use of such a program? If you only use a high-level language such as Basic, it is of no value at all. However, if you work in machine code, you will often meet apparently useful listings you cannot use because you have the wrong micro.

For instance, you might want to take a program for the 6502 in an Apple, and run it on your Video Genie Z-80. To do it, you would have to understand fully the original listing, and effectively work out its flowchart. You could then re-write it in Z-80 code. A translation program would do all this work for you — feed it 6502 code and it gives you Z-80 code.

Why 6502 to Z-80 translation? There are two main reasons. In the first place, it is easier than the other way, and in the second place, I own a Z-80-based computer.

At this point, it is worth seeing just why it is easier to go from 6502 to Z-80. For those of you who did not see my earlier series, let us have a quick look at the architecture of the two micros.

6502 architecture. Figure 1 shows the basic 6502 configuration. The micro has a single eight-bit accumulator, in which all the arithmetic is done, and a status register, containing flags which show the results, e.g., carry generated, accumulator zeroed, etc., of the majority of the operations performed.

There are two eight-bit index registers, X and Y, which are, in many ways, interchangeable and can be used for temporary data storage, as loop counters, and as indices for the micro's numerous addressing modes. I shall return to the subject of

Figure 2. Basic Z-80 architecture.

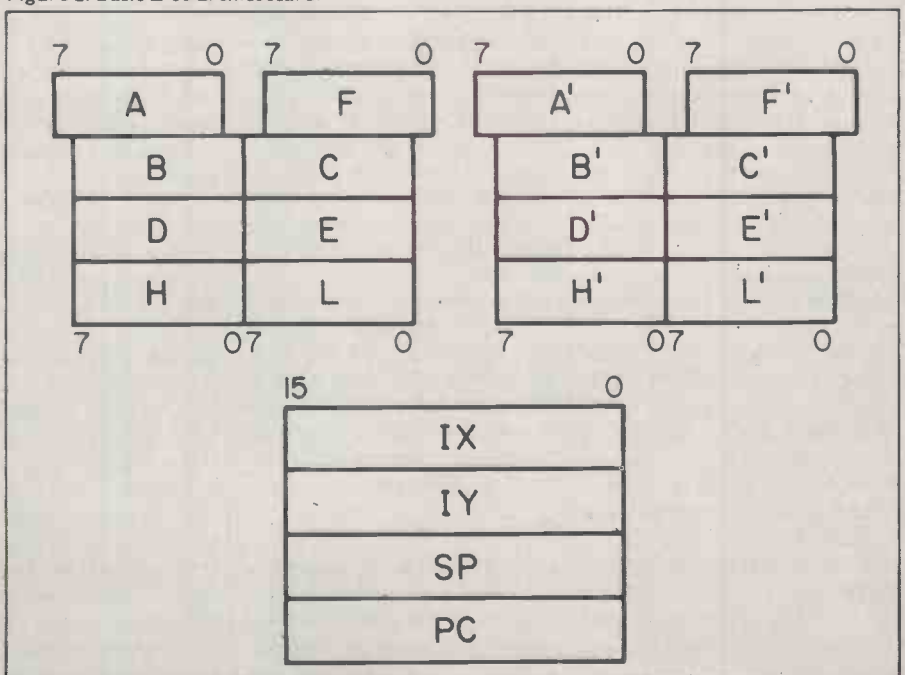

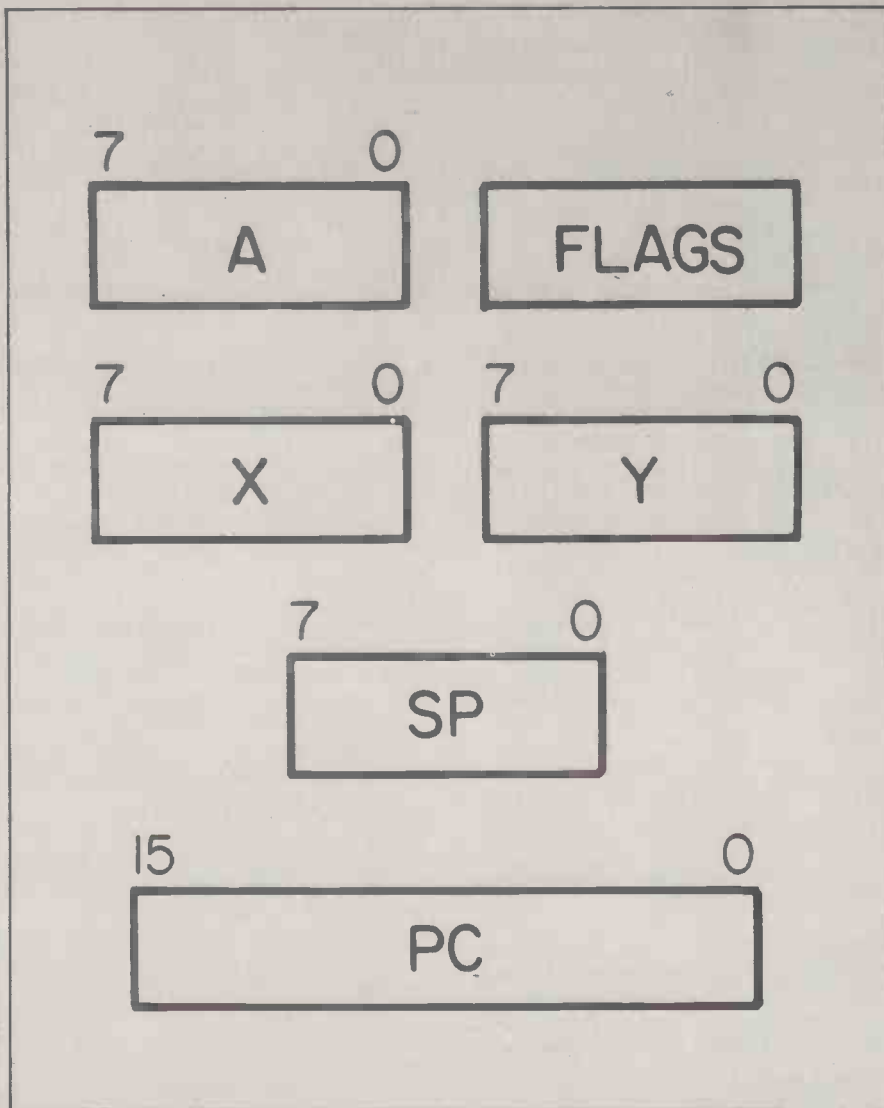

Figure 1. 6502 architecture.

6502 addressing modes in more detail later.

The 6502 also has an eight-bit stack pointer, SP, which is used to point to a stack permanently located on page 1 of memory, and a conventional 16-bit program counter, PC.

Z-80 architecture. The architecture of the Z-80 is shown in figure 2. The micro is obviously much more complex than the 6502, and its structure centres around two sets of working registers. It can use either set at any given time, but not the two together.

Each set has an eight-bit accumulator, A, with its associated flag register, F, and six general-purpose eight-bit registers, B-E, H,L. These six registers may be concatenated into three 16-bit registers, BC, DE and HL, in order to perform either limited 16-bit arithmetic, or to give pointers to anywhere in the micro's memory space. HL is more useful than either BC or DE.

The Z-80 also has a 16-bit SP, which means that the stack can be anywhere in memory, and a 16-bit PC. It also has two 16-bit index registers, IX and IY. The action of these two is very different from

that of the 6502 X and Y, and I shall not be using them. So you can forget about them again.

Similarities between the micros. Both micros have an eight-bit accumulator, in which virtually all arithmetic is performed, and both offer substantially the same operations — the Z-80 actually does a few more than the 6502. The results of the operations are reflected in the flags, and both chips have almost equivalent carry, zero and sign flags. The PC operation is effectively identical in the two micros, and the 6502 eight-bit SP is a subset of the Z-80 16-bit one.

Major differences. The most important difference between the two micros lies in their addressing modes. The 6502 has a very rich choice of indexed, indirect and compound modes, as well as the more obvious immediate and absolute modes.

The Z-80, on the other hand, effectively has only immediate and indirect operations; the latter use HL as a pointer. It is possible to load and store A via absolute addressing, but you cannot, say, add directly to A in this mode. The micro has a form of indexing, but as I mentioned, it

(continued on next page)

**Super
Machine
Code
Word
Processor**
£35 + VAT



All you'd expect in a £75-£150 program, PLUS redefine keyboard, auto repeat, tape or disk files, old & new ROMs, PET or ASCII printer, AND 80-column PETS. No need to change when you upgrade. We didn't believe it either! £35 tape can be saved to disk, has 80-column mod listing. £37 disk includes sample files plus full 80-column version.

LIGHT PEN + SOFTWARE — plugs in. £22

PROGRAMMER'S TOOLKIT — 16/32K new ROM: makes programming less like work! £29

ADVENTURE 1 & 2: authentic Scott Adams 24K classic games. Each £7 (both, £13)

FANTASTIC MUSIC MACHINE: hardware + software to write music on your PET and see it play. Add small speaker or play through hi-fi, 4 voices. Transpose, change tempo, repeat segments etc just by typing a row of characters. Save music to disk or tape. Beautifully simple: write tunes within minutes! Old & new ROMs, 8-32K. £37 complete.

Add VAT to all prices please, but post/insurance included. **Unconditional Instant Refund Guarantee** on hardware, also software if not up to description. Write for more details, more items.

SIMPLE SOFTWARE LTD
15 HAVELOCK ROAD
BRIGHTON, SUSSEX BN1 6GL
(0273) 504879



• Circle No. 183

MICROCASE "turns a board into a real computer"
For **NASCOM 2**
COMPUKIT
SUPERBOARD
ALSO UN CUT FOR **NASCOM 1**
ETC.

Direct from us or from your dealer — but make sure you see a

GENUINE MICROCASE

SIMPLE SOFTWARE LTD
15 HAVELOCK ROAD
BRIGHTON, SUSSEX BN1 6GL
(0273) 504879



• Circle No. 184

ZX80 LEARN QUICKLY WITH
PROGRAM INTERCHANGE CLUB

£1.00 tape and 50p manuscript exchange. Increase your program library fast, by joining P.I.C. Tape or manuscript program interchange service — programming aids — binders — indexes — free competitions for Club members.

Send cheque/postal order £5.00 annual membership — rules — full details and free samples — payable to:-

PROGRAM INTERCHANGE CLUB



2 NEWTOWN
CHICHESTER
WEST SUSSEX PO19 1UG
DEPT 093

• Circle No. 185

ZX80

USER PORT MODULE

Start using your ZX80 in control applications (Robotics, Household systems, Model trains, etc.)

£29 inc. p&p.

- ready built and tested
- plugs into ZX80
- sample control programs supplied on C12 cassette
- gives 8 input and 8 output lines
- applications and software booklet included

cheque with order to:

J.M.J. INTERFACES

Old School House, Rettendon Turnpike, Battlesbridge, WICKFORD, Essex.

• Circle No. 186

SPECIAL OFFERS

MATRIX PRINTER



- Print Speed 125 C.P.S.
- Unidirectional or Bi-directional 70 L.P.M.
- 96 Character A.S.C.I.I. set.
- Print Density 40 or 80 C.P.L.
- Pin Feed paper handling.
- Width from 4.5 to 9.5 inches.
- Prints original plus two carbons.
- Parallel centronics compatible.

£295

+ VAT AND P&p.

PET, APPLE & TANDY interfaces available

COMPUTHINK DISK DRIVE & EXPANDERMEM FOR 8K PET

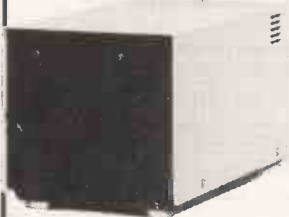

Transform your old ROM Pet into a complete system.

- 800K Bytes of on line storage.
- Expandermem board makes your 8K PET into a 32K PET.

£650

p&p £5.00 + VAT

KINGSTON

Kingston Computers Limited, Electricity Buildings, Filey, Yorkshire, U.K. Telephone: 0723 514141 Telex: 52163

• Circle No. 187

The Dream Machine

Fantasy, fact and fiction with the

ISC 36XX

Micro system with 64 colour combinations

Prices from £1200 with micro floppy

COPERNICUS (0428) 52888
7 Way Hill, Haslemere, Surrey.

• Circle No. 188

(continued from previous page)

is totally dissimilar to that of the 6502.

The other major area of difference is in the way that the two micros use their flags. For a start, the 6502 sets its flags whenever it loads or manipulates A, X or Y; the Z-80 alters flags only after an arithmetic or logical operation. In subtraction and comparison operations, the 6502 sets its carry flag to show no borrow, while the Z-80 clears it to show the same state. During addition, both micros work in the same way.

The Z-80 lacks the 6502 break and decimal flags, and its overflow flag is only roughly equivalent to that in the 6502. The Z-80 does not have an interrupt flag either, but it can obtain the same effect another way. On the other hand, the Z-80 has two flags which the 6502 lacks.

That sounds like a depressing list of differences, but when you examine them, it is possible to fool the Z-80 into behaving much like a 6502. There are some grey areas, like the overflow flag, but in practical terms they are not

gives:	...	ABS,X
	LD	HL,ABS
	CALL	IXIX
IXIX	EX	AF,AF' ;SAVE FLAGS
	ADD	HL,BC ;INDEX
	EX	AF,AF' ;RESTORE
	RET	

Figure 3. ABS,X mode.

important. In fact, there are only four 6502 instructions which cannot be translated to a Z-80 format. They are SED, SET Decimal, CLD, CLear Decimal, BRK, BReak, and BIT, Bit Test. Otherwise, translation is possible.

The basic translation approach is to use the registers of the Z-80 to emulate those of the 6502. The two accumulators, flag registers, SPs and PCs are equivalent and so present no problems. C is used to represent X, and E models the Y register. By keeping B and D at zero, we can then, as you will see, work through HL to obtain the same effects as the 6502 addressing modes.

You will probably have gathered by now that the translation program will handle one 6502 instruction at a time — not an ideal approach. It was constrained, however, by a need to fit the program into 16K. With more RAM, it would not be too difficult to generate a rather more intelligent program, able to translate the sense of small blocks of 6502 code into equivalent Z-80 instructions.

Inevitably, this translation approach causes a growth in code size. A translated program will take up about three times as much RAM as the original, and run at about one-third of the speed. In real terms, I do not consider either of these penalties would be significant in the vast majority of cases. The need to watch every last byte and microsecond is often a hangover from the very early days of computing.

So, we will translate programs by taking

- | | |
|----|---|
| A. | Untranslatable:
BIT, BRK, CLD, SED |
| B. | Single-line, no operand:
CLI, DEX, DEY, INX, INY, NOP,
PHA, PHP, RTS, SEC, SEI |
| C. | Single-line with operand:
BCC, BCS, BEQ, BMI, BNE, BPL,
BVE, BVS, JSR |
| D. | Standard format:
ADC, AND, ASL, CMP, DEC, EOR,
INC, JMP, LSR, ORA, ROL, ROR,
STA, STX, STY |
| E. | Irregular — short:
CLC, PLA, PLP, RTI, TAX, TAY,
TXA, TYA |
| F. | Irregular — long:
CLV, CPX, CPY, LDA, LDX, LDY,
SBC, TSX, TXS |

Table 1. 6502 instruction categories.

a single line of 6502 code, and replacing it with functionally equivalent Z-80 code. With an operation like ADD, or LDA, this is quite straightforward. Some operations, for example CLV, are much more complex.

If you like, the translation program is a specialised macro-assembler for the Z-80. On the other hand, it is also an off-line 6502 emulator; on-line emulators slow execution time by a factor of 50 or so.

The first problem, then, is how to translate the 6502 operations. I have not space to list all the details — if you really want to know, you can winkle them from the program listing next month. I will say, however, that the 6502 instructions fall into six general categories — table 1.

Untranslatable instructions are self-explanatory. The single-line commands are ones in which, as you might guess, a single line of Z-80 code can replace a single 6502 operation. Some of those operations use implied addressing, while

gives:	...	ABS,Y
	LD	HL,ABS
	CALL	IXIX
IXIX	EX	AF,AF'
	ADD	HL,DE
	EX	AF,AF'
	RET	

Figure 4. ABS,Y mode.

the second group, all branches and jumps, use a relative or absolute address. To give examples, the 6502 instructions:

DEY

and:

BNE LOOP

can be translated exactly by:

DEC E

and:

JR NZ,LOOP

The standard multi-line translations define a group of commands in which the basic operation can be translated by a single line, which must then be topped and tailed by other lines to control flags and the addressing mode.

All the instructions in the standard group need identical topping and tailing. For example:

ADC STOREI

can be translated as:

LD HL,STOREI

ADC A,(HL)

and:

EOR TEST
becomes:

```
LD HL,TEST
XOR (HL)
```

In general, all these translations involve setting HL to the operand address, and then performing the equivalent Z-80 operation using HL as a pointer.

The first three groups of translatable instructions obviously lend themselves to translation by a methodical technique. We have only to identify the operation, provide the single equivalent Z-80 opcode, and add the operand, which has a regular format.

The last two categories, however, do not fall into a regular pattern. The only reason that I think of two categories at all

gives:	...	(IND,X)
LD	HL,IND	
CALL	IXIND	
EX	AF,AF'	
ADD	HL,BC	;NEW POINTER ADDRESS
LD	A,(HL)	;LOW BYTE...
INC	HL	
LD	H,(HL)	;HIGH BYTE...
LD	L,A	...OF POINTER
EX	AF,AF'	
RET		

Figure 5. Indexed indirect.

is because of the way in which the translator works. Each 6502 instruction in these groups must be handled as an individual. For instance:

TAX

becomes as:

```
LD C,A
INC C ;THESE 2 LINES
DEC C ;SET THE FLAGS
```

while:

CPY ≠ SABC

has to become:

```
LD D,A ;SAVE A
LD A,E ;A = Y
CMP 0ABCDH
CCF ;ADJUST CARRY FLAG
LD A,D ;RESTORE A
LD D,B ;D=0 AGAIN
```

We have to adjust the carry flag because the two micros affect it in different ways. In the translated program, the flag is held at its 6502 status. It has, therefore, to be complemented before and after subtraction, and after compares, to keep things in order.

In fact, the flags cause a problem all the way through, as the 6502 changes them far more often than the Z-80. I found that the easiest way to set the flags after, say, loading A from memory was to use:

```
INC A
DEC A
```

The shorter alternative, 'OR A', would zero the carry flag, which we do not want.

It is no use being able to translate operations of a 6502 if we cannot also translate all its addressing modes. The absolute and immediate modes are not too difficult, and neither is the pure indirect mode — but only JMP (x) uses that. It makes no difference to the translation whether or not Page zero addressing is in use — the Z-80 always uses 16-bit addresses.

Somehow, though, we have a deal with

the 6502 indexed, indirect-indexed and indexed-indirect modes. Fortunately, the rules for each of these modes are precisely defined, and, at the expense of a few lines of code, it is possible to emulate them all with a Z-80.

The basic technique I chose was always to load HL with the central label of the operand, e.g., 'TOTAL' from 'LDA (TOTAL,X)'. It is followed by a call to one of four possible subroutines, which modify HL to point to the actual address intended. When the whole program is translated, any of the four subroutines actually called by the translation is added to the output. Figures 3-6 show the four subroutines.

Why subroutines? Mainly to minimise the size of the translated program. Inline code would run a little faster and would avoid the slight risk of the subroutine's corrupting the stack. On the other hand, it would make the translation much longer. Using macros would, at least, control the size of the output listing, but would still give plenty of object code. Furthermore, not all Z-80 assemblers have a macro facility. I decided, therefore, that the subroutine approach was the least undesirable one.

As an example of this technique in action:

EOR (STORE2),Y

translates as:

```
LD HL,STORE2
CALL INDIX
XOR (HL)
```

The heart of the translator is its handling of the 6502 operations and addressing modes. Once that is resolved, the rest of the program reduces to little more than

gives:	...	(IND),Y
LD	HL,IND	
CALL	INDIX	
EX	AF,AF'	
LD	A,(HL)	;LOW BYTE...
INC	HL	
LD	H,(HL)	;HIGH BYTE...
LD	L,A	...HL = POINTER
ADD	HL,DE	;OFFSET
EX	AF,AF'	
RET		

Figure 6. Indirect indexed.

control structures and facilities for reading the source code and outputting the translation.

I do not intend to go into the details of the actual implementation — I shall cover that in part 2. It is, however, worth looking at just what the program has to do, and how it should go about doing it.

A program of this complexity is difficult to describe with flowcharts. A more flexible technique is to use a Program Definition Language, PDL, and listing 1 is a specification for the translator, written in a simple PDL.

If you have not seen a PDL before, it describes a program in a format independent of any specific programming language — actually, it looks vaguely like

(continued on next page)

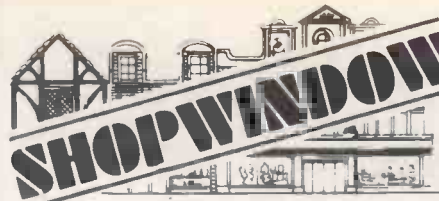

COLCHESTER

APPLE
NEWBRAIN — UK sale &
SHARP hire
TANDY PKT, I, II
VIDEO GENIE

Printers and Accessories
Electronic Components
Secondhand Computers etc
eg Centronics 702 £450
Ample parking

EMPRISE
(0206) 865926

58 EAST STREET
COLCHESTER
near ROSE & CROWN

• Circle No. 189

BIG EARS

SPEECH
INPUT
FOR
YOUR
COMPUTER!



BIG EARS opens the door to direct man-machine communication. The system comprises analogue frequency separation filters, preamps and signal conversion, together with a quality microphone and extensive software.

Words, in any language, are stored as "voice-prints" by simply repeating them a few times in "learn" mode. Using keyword selection techniques, large vocabularies can be constructed.

Use BIG EARS as a front end for any application: data enquiry, robot control, starwars — the possibilities are unlimited...

BUILT, TESTED & GUARANTEED ONLY £45!

PRICE INCLUDES POSTAGE & PACKING PLEASE ADD VAT AT 15%
PLEASE STATE COMPUTER: UK101, SUPERBOARD, NASCOM2,
PET, TRS80, ETC.

MICROGRAPHICS

Colour Conversion for
UK101/NASCOM 1 & 2/ Superboard. KIT £45
(Modulator included) BUILT £60

COLOUR MODULATOR

RGB In, PAL/UHF out KIT £12
BUILT £18

Please add VAT at 15% to all prices
Barclay Access orders accepted on telephone

WILLIAM
STUART
SYSTEMS Ltd
Dower House, Billericay Road, Essex
Herongate, Brentwood, Essex CM13 3SD.
Telephone: Brentwood (0277) 810244

• Circle No. 190

NASCOM SOFTWARE

We offer the following quality software for NASCOM systems:

NASPAS — a 12K PASCAL compiler which produces 280 code directly i.e. no P-code.

The compiler offers floating point and Integer arithmetic, arrays, sets, strings and all major Pascal statements together with fully recursive functions and procedures with value and variable parameters. The object programs run very quickly.
Price: £35.00.

NASMON — a new monitor for NASCOMs. Occupies 4K and includes a sophisticated screen editor, a "front panel" mode, blocked and buffered tape routines and powerful debugging commands.
Price: £30.00 in EPROM.

BAS12K — a 12K BASIC interpreter offering 11 digit precision arithmetic, PRINT USING, IF...THEN...ELSE and other advanced features.
Price: £25.00.

NASGEN — a fast 3K assembler generating a full symbol table and with many assembler directives and commands.
Price: £15.00 on tape, £25.00 in EPROM.

NASDEM — a 2½K disassembler which interfaces to NASMON's front panel to produce single step disassembly. Optionally it produces labels and o/p may be directed to a text buffer suitable for NASGEN.
Price: £10.00 on tape, £15.00 in EPROM.

All the above software runs under NASMON except NASPAS which can run under NASMON or NAS-SYS. All prices are fully inclusive.

FREE: a free CHESS program with every order of NASMON.
Full details may be obtained from:

HISOFT 60 Hallam Moor, LUDEN, SWINDON, Wiltshire.

• Circle No. 191



MAKE THE MOST OF YOUR MICRO

A RANGE OF ONE AND THREE DAY COURSES COVERING THE FOLLOWING:

CPM, BASIC, SYSTEMS ANALYSIS AND DESIGN. BUSINESS-MAN'S OVERVIEW AND WORDSTAR

CONTACT
THE EDUCATION CENTRE
70-72 HONOR OAK PARK SE23
TEL: 01-699 2202

• Circle No. 192

MAINTENANCE OR SERVICE CONTRACT FOR APPLE

Throughout North West England
Same day service
Very attractive rates
Please write for details or phone

NORTHERN COMPUTERS
128 Walton Rd., Warrington WA4 6NP.

0925-601683

SUPERB QUALITY OLIVETTI DAISYWHEEL PRINTERS £1295

EVERYTHING FOR APPLE
PART EXCHANGE YOUR SINCLAIR ZX80 FOR AN APPLE.

SECOND HAND SINCLAIRS £59
SUBJECT TO STOCK

NORTHERN COMPUTERS
128 Walton Rd Warrington WA4 6NP

0925-601683

• Circle No. 193

ZX80 ACORN ATOM!

The monthly magazine INTERFACE gives at least six complete programs for each computer, plus hints and tips.

Large s.a.e. for free copy.

INTERFACE 44 EARLS COURT ROAD,
LONDON W8 6EJ.

• Circle No. 194

(continued from previous page)

Pascal. The PDL itself has very few reserved words — BEGIN, END, IF, END IF, THEN, ELSE, DO WHILE, etc. They define the program's flow, and are always written in capitals. The other words in capitals are the names of functional elements of the program — roughly, they represent subroutines. The lower-case text shows what each part of the program has to do.

With this approach, you can define a program in as much, or as little, depth as you want before you start coding. Also, as you can see, it forces you to use a structured approach. It is, therefore, a good way not only of describing a program, but it is also a good way of planning one.

I hope that the listing is reasonably easy to follow, and shows the logic of the program clearly. You have probably noticed that it is rather short on description in some areas, and that it is for one of two reasons.

The segment 'TRANSLATE LINE' is also very brief, and I have only given one example of the routines it calls. I have not shown the details of translating specific 6502 operations. If you want to know how each opcode is tackled, you can work it out from next month's listing.

The translation has to do a reasonable amount of syntax checking. However, do not expect it to do a full check of the source code. It only has to look for errors which might confuse it. Examples are:

- Comments not starting with ';'.
- Operation field not having three characters.
- More than six characters in a label.
- Labels not starting with a letter.
- Non-label, or non-immediate, operand fields.

Some errors could, therefore, slip through, but should be caught by the Z-80 assembler after the translation.

In next month's article, I shall detail how to use the translator. It is worth noting, however, a few of its limitations. I do not think that any are too serious. The operand field can only be a label, or an immediate quantity, in the latter case, it must start with '#'. In other words, you cannot use: LDS \$12B7 or similar expressions.

The 6502 has a very useful ability to handle BCD quantities directly. With more space, that could have been translated, but I could not fit it into 16K. Because the Z-80 PUSHes and POPs move two bytes at a time, compared to the 6502's one, you can only have a maximum of 128 items on the stack at any one time. That is because the translated program's stack must be confined to a single page. Also, manipulating data in the stack may occasionally cause corruption.

On the other hand, the translator will handle a more complete and rational set of addressing modes than the 6502 provides. As far as the program is concerned, every instruction which addresses memory can use any addressing mode

other than implied. As you know, the 6502 imposes an apparently arbitrary set of restrictions on what modes you can use when.

This bonus feature of the translator arose because it was easier to leave in, rather than to try to trap all the exceptions — now you can use 'STX (IND,X)' with impunity.

Listing 1.

```

BEGIN TRANSLATION
INITIALIZE SYSTEM
DO WHILE there is a program to be translated
  INPUT DATA
  IF data overflow
    THEN
      warn operator
    ENDIF
  DO WHILE there is data to be translated
    PARSE DATA LINE
    TRANSLATE LINE
    SAVE TRANSLATION
  ENDO
  WRAPUP TRANSLATION
END DO
END TRANSLATION

BEGIN PARSE DATA LINE
IF comment line
  THEN
    indicate comment line
  ELSE
    read label, operation, operand, comment fields
  ENDIF
CHECK FOR SYNTAX ERRORS
IF no errors
  THEN
    BEGIN
      IDENTIFY OPCODE
      IF opcode OK
        THEN
          IDENTIFY ADDRESS MODE
        ELSE
          set error flag
        END
    END
  ENDIF
END PARSE DATA LINE
BEGIN TRANSLATE LINE
IF error
  THEN
    INDICATE ERROR
  ELSE
    CASENTRY operation type
      CASE untranslatable
        INDICATE UNTRANSLATABLE
      CASE single-line and no operand
        TRANSLATE ONE LINE
      CASE single-line and operand
        TRANSLATE ONE LINE AND OPERAND
      CASE 'standard' group of operations
        STANDARD TRANSLATION
      CASE irregular-short
        TRANSLATE IRREG-SHORT
      CASE irregular-long
        TRANSLATE IRREG-LONG
      ENDCASE
    ENDIF
  END TRANSLATE LINE
BEGIN SAVE TRANSLATION
write 'output' to VDU
IF tape drive switched to 'record'
  THEN
    WRITE OUTPUT TO TAPE
  ENDIF
END SAVE TRANSLATION
BEGIN WRAPUP TRANSLATION
IF 'IXIX' called
  THEN
    'output' = IXIX
    SAVE TRANSLATION
  ENDIF
IF 'IXIY' called
  THEN
    'output' = IXIY
    SAVE TRANSLATION
  ENDIF
IF 'IXIND' called
  THEN
    'output' = IXIND
    SAVE TRANSLATION
  ENDIF
IF 'INDIX' called
  THEN
    'output' = INDIX
    SAVE TRANSLATION
  ENDIF
IF 'IND' = 'END'
  SAVE TRANSLATION
END WRAPUP TRANSLATION
BEGIN CHECK FOR SYNTAX ERRORS
IF bad label
  THEN
    set error flag
  ELSE
    IF operation format wrong
      THEN
        set error flag
      ELSE
        IF comment field format wrong
          THEN
            set error flag
          ENDIF
        ENDIF
      ENDIF
    END CHECK FOR SYNTAX ERRORS
BEGIN IDENTIFY OPCODE
check list of allowable opcodes
  
```

```

IF opcode found
THEN
  record opcode number
ELSE
  set error flag
ENDIF
END IDENTIFY OPCODE

BEGIN IDENTIFY ADDRESS MODE
IF no operand
THEN
  implied
ELSE
  IF operand = 'A'
  THEN
    accumulator
  ELSE
    IF first character a letter
    THEN
      IF penultimate character a ','
      THEN
        IF last character 'X' or 'Y'
        THEN
          INDEXED
        ELSE
          set error flag
        ENDIF
      ELSE
        IF last character alphanumeric
        THEN
          absolute
        ELSE
          set error flag
        ENDIF
      ENDIF
    ELSE
      IF opening bracket
      THEN
        IF ',X)' end
        THEN
          indexed indirect
        ELSE
          IF ',Y' end
          THEN
            indirect indexed
          IF ')' end
          THEN
            indirect
          ELSE
            set error flag
          END IF
        ENDIF
      ENDIF
    ELSE
      IF opening '# '
      THEN
        immediate
      ELSE
        set error flag
      ENDIF
    ENDIF
  ENDIF
ENDIF
END IDENTIFY ADDRESS MODE

BEGIN INDICATE ERROR
'output' = error message + faulty line of source code
END INDICATE ERROR

BEGIN STANDARD TRANSLATION
IF addressing mode unsuited to operation
THEN
  INDICATE ERROR
ELSE
  extract translated operation
  IF immediate or accum. mode
  THEN
    'output' = label + operation + operand + comment
  ELSE
    IF indexed
    THEN
      select appropriate CALL
    ELSE
      'output' = label + 'LD HL,' + operand + comment
    ENDIF
    'output' = 'output' + operation + '(HL)'
  ENDIF
ENDIF
END STANDARD TRANSLATION

```



apple
in Avon & Bristol

with full Software Support for business and professional use, including Invoicing, Ledgers, Stock Control, Word Processing, Hotel Systems, Petrol Station Management, Data Base, Mailing Lists and many other applications.
Dataforce (U.K.) Limited,
Bush House, Prince Street,
Bristol BS1 4HU.
Tel: 279016.

Dataforce
Systems Software

• Circle No. 195

UNDECIDED STRIKE NOW

PET		RRP	OUR PRICE
4008N	8K	£450	£405
4016	16K	£550	£495
4032	32K	£695	£626
8032	32K	£895	£806
Disk Drive			
4040	343K	£695	£626
8050	950K	£895	£806
Printers			
4022	80COL	£395	£356
8024	132COL	£1160	£1044
8026	DAISY	£995	£896

VAT to be added to the above figures.
Carriage — £5 per item.

If you know what you want why wait?
These are the prices you need.

ORCHARD COMPUTER SERVICES
Orchard House, 21 St Martin's Street,
Wallingford, Oxon
Tel. Wallingford 0491-35529
OPEN 6 DAYS PER WEEK

• Circle No. 196

FULLY ASSEMBLED & TESTED **FROM £39.50**
+VAT
Can be used with TANGERINE TRITON ACCORN etc.

Professional ASCII Keyboards

All complete with Metal mounting frames

Coming soon: 12 High Resolution Data Display suitable for Apple etc.

MODEL KB 771 B 72 Key £59.50
MODEL KB 756 MF 56 Key £39.50

CARTER KEYBOARDS

Accessories supplied with Keyboard only:

DC to DC Converter	DC 512	£5.00
--------------------	--------	-------

(for operation off single 5v supply)

Model 756 MF Only

Edge Connector	KB 15 P	£1.95
Numeric Key Pad	KB710	£7.50
Plastic Case (Black)	KB705	£12.75

UK Orders add 15% VAT on order total
Overseas Orders add £2.00 p&p.

FULL DATA SHEET ON REQUEST
CITADEL PRODUCTS LIMITED
Department PC, 50 High Street Edgware
Middlesex HA8 7EP Telephone: 01-951 1848

• Circle No. 197



DELTA SYSTEMS LTD

Agents for DYNACOMP SOFTWARE

PET, APPLE II Plus	TRS 80 (Level II)
BRIDGE 2.0	£7.50
Hearts 1.5	£6.25
Cribbage	£6.25 (TRS-80 only)
Chessmaster	£8.30 (TRS-80 only)
Startrek 3.2	£4.00
Space Tilt	£4.50 (Apple only)
Games Pack 1	£4.00
Games pack 2	£4.00
Graphix	£5.50 (TRS-80 only)
Tidy	£4.50 (TRS-80 only)
Data Smoother	£6.25
Fourier Analyzer	£6.25
Transfer Function	£8.30
Regression 1	£8.30
Regression 2	£8.30
Black Hole	£6.25 (Apple only)
Valdez	£6.25
Flight Simulator	£6.25
Text Editor	£6.25

All programs on tape with superb documentation.
VAT extra. Postage 20p.
Send for full detailed list.

**32 FINCH ROAD, DOUGLAS, ISLE OF MAN
0624 27522**
Trade Enquiries Invited

• Circle No. 198

Cromemco Users Take Note!

Hard Disk Back Up

Tape Cartridge Device together with S100 card and special File Security Software for CDOS & Cromix.

Cromix software provides file and directory tree back up.

£1950.00
(plus VAT)

Now available from:

Wheatcroft Hards Ltd.
BRACKENHILL, THE COMMON,
BERKHAMSTED, HERTS.
Berkhamsted (04427) 3842
Cromemco Software Specialists

• Circle No. 199

ITT2020 SOFTWARE APPLE II

DATABASE is a program that writes a program. DATABASE can create a flexible record-keeping system custom designed to YOUR specification.

HUNDREDS OF MEMBERSHIP DETAILS OF MEDICAL RECORDS APPLICATIONS MAILING LISTS, ETC a direct replacement for the CARD INDEX

Simply draw the format you require on the screen using the editor. Then let the computer do the rest! Easy to use.

FEATURES: protected screen editing automatic date and number checking comprehensive search & print functions

£120+V.A.T. for the complete system!

Phone 01-242-7394 or write for details

DISK DEAN LTD
23 BEDFORD ROW, LONDON WC1R 4EB

• Circle No. 200

Tracking down the cause of Pet's disc-drive problems

THE PET dual drive floppy disc unit with its 15 memory chips and two microprocessors is a much more intriguing device than many conventional disc systems. My interest in the operation of the 2040 disc unit was aroused when people started to bring their machines to us, I am technical services manager at Intelligent Artefacts Ltd, complaining of being unable to load programs which had been previously saved using the same machine.

After eliminating a variety of problems

commands, M-W, are executed. A buffer pointer command, B-P, is used to indicate where in the buffer reading or writing is to start — see figures 1 and 2.

Track 18 is of special interest when looking for any corruption which may be causing loading problems as that is the track reserved for disc administration. The first sector on track 18 is the block availability map indicating how full the disc is, and also the disc ID — the information put in by the user when Newing the disc.

by P Krueger

The rest of the sectors on track 18 are used as a directory of the files stored on the disc. Each sector of the directory is split into eight file entries which hold the following information.

caused by discs being wedged tightly in their envelopes, or so loose that they did not settle down on to the conical mandrel correctly, and a case of burnt-out integrated circuits on the memory board, we were left with problems which could not be traced to hardware at all.

The only remaining possibility was that the discs were being corrupted in some mysterious way. So a program was written which would enable a disc to be accessed sector by sector and analysed. Even to begin to do this, we had to know exactly how the disc system operated and how data was held on disc.

1. A code to differentiate programs from data files.
2. An address, track and sector, at which the file starts.
3. The name of the file.
4. The number of blocks used by the file.

The program was built up to perform the following tasks:

Data is passed between the physical disc and the disc unit memory when user commands 1 or 2 are executed. One block of data is transferred between a specified sector of a track and a buffer in the disc unit memory.

- Read a block of, or contents of, a sector from the disc and display it on the Pet screen in both Hexadecimal notation and Ascii. Hex was used to ease screen formatting.
- Each disc sector is displayed on the screen in two passes; one for bytes 1-127 and then after clearing the screen, bytes 128-255 are displayed.
- We decided not to scroll the screen output as the information would need to be translated and studied.
- There was also another reason why the output should be held static on the screen: the user should be given a

Data is transferred between the disc unit memory and the Pet memory when memory read, M-R, or memory write

Figure 1.

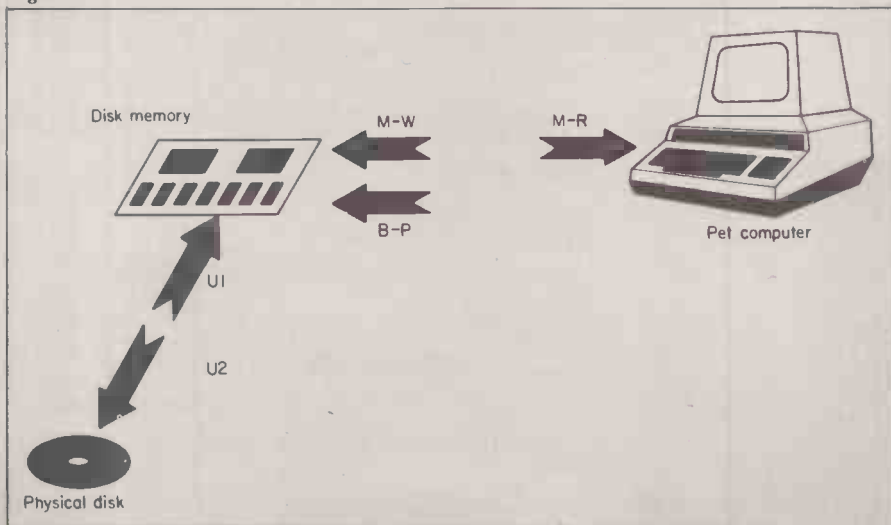



The disk itself is structured in the following way

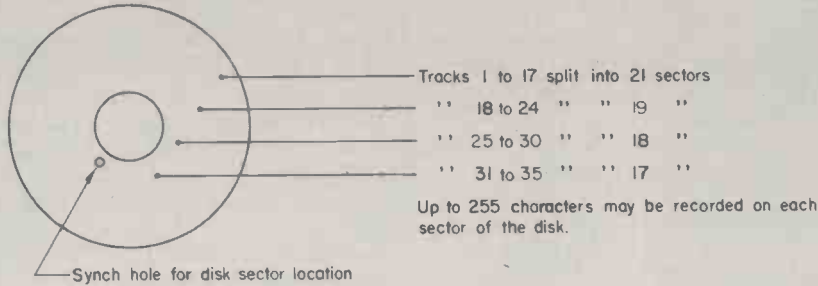

Figure 2.

chance to remove any corruptions found on the disc. The edit mode to do this works by the line to be changed being input by the user, i.e., 1 to 16. The cursor then moves up and deletes the line requested and waits until the user types the correct data in decimal notation. The edited sector is then written into the disc memory and then read out again in Hex to be checked. Once checked, it can then be written on to the physical disc itself from the disc memory.

The program was first used on a disc which would not respond to LOAD "*", 8 which should load the first file in the disc directory, but was instead causing read errors. By running the disc debug program, we found the following on track 18 sector in the second section of bytes, 127-255 — see example 1.

Example 1.

```

00 00 00 00 00 00 00 00 00 00 00000000
00 00 00 00 00 00 F5 07 01 0000000A
00 43 4F 40 57 4F 52 44 50 COMMORDF
00 52 4F 20 49 49 49 A0 A0 RD III
00 A0 A0 40 41 20 20 A0 A0 MA
00 A0 A0 A0 00 00 00 00 00 000000
00 00 00 00 00 33 31 20 53 000031,S
00 59 4E 54 41 58 20 45 52 VNTAX ER
00 52 4F 52 20 30 30 20 30 ROR,00,0
00 30 00 30 30 00 20 20 00 RMOON 0
00 00 00 00 00 00 00 00 00 00000000
00 00 00 00 00 00 00 00 00 00000000
00 00 00 00 00 00 00 00 00 00000000
00 00 00 00 00 00 00 00 00 00000000
00 00 00 00 00 00 00 00 00 00000000
00 00 00 00 00 00 00 00 00 00000000
00 00 00 00 00 00 00 00 00 00000000
00 00 00 00 00 00 00 00 00 00000000
    
```

contents of channel 15 written on to the disc.

The corruption was deleted by re-writing lines 7, 8, 9 and 10 using Disc Debug. The corruption had been caused by the power to the machine being turned-off while the disc was still in the drive.

That has been the most common cause of the disc corruption found so far and illustrates the need to ensure discs are removed from the drive — even if they have write protects — when powering-down. The corruption itself was an error message written from channel 15 when the power was cut. It demonstrates the problem with two-state systems of predicting the result of unexpected power loss.

Once we had found this method of editing discs directly, it was tempting to examine the way programs were structured on the disc. A program was assembled which joined two routines (continued on next page)

A Complete New Computer-Driven Home Study Course in German

9 Apple/ITT Diskettes 6 Audio Cassettes
Textbook with illustrations (206 pages)
Workbook — 250 pages Beginners to post O-Level.

**Introductory Offer (till 30 June)
£99 excl. VAT**

Classroom version (full sets of textbooks) also available. Try us for single disks of testing routines. Send for Details to:

WIDA Software
2 Nicholas Gardens, London W5 5HY
(01)-567-6941 or (062)-882-5206

• Circle No. 201

MICRO COMPUTER HOBBYISTS

Earn Money Part-time

If you are a Micro Computer enthusiast or keen to learn and have two evenings a week free do not miss this opportunity to capitalise on your knowledge.

For further information write with details of your experience to

Box No 100 PRACTICAL COMPUTING, QUADRANT HOUSE, THE QUADRANT, SURREY, SM25AS.

• Circle No. 202

STOKE on TRENT

for
TUSCAN
and
TANGERINE
and
VIDEO GENIE + SOFTWARE
and
BOOKS

MICRO-PRINT Ltd.,
59, Church Street, Stoke on Trent.
(0782) 48348. Barclaycard and Access

• Circle No. 203

CP/M SOFTWARE

FOR MANUFACTURING & GENERAL BUSINESS.

- BILL OF MATERIALS
- STOCK/WIP CONTROL
- PIECE-WORK AND PAYROLL
- ACCOUNTING

ALSO SUPPLIERS OF:-

VECTOR GRAPHIC HARDWARE

TAYLOR MICRO SYSTEMS

HAMSTEAD INDUSTRIAL ESTATE
OLD WALSALL ROAD, GREAT BARR,
BIRMINGHAM B42 1DF 021-358 2436

• Circle No. 204

D BRUCE ELECTRONICS

THE BEACON,
BLACKHALL ROCKS
CLEVELAND TS27 4BH
Tel. (0783) 863612



dimensions
75 x 50 x 28mm

The KSI is a single connection to the Sinclair ZX80. FOR EVERY keyboard entry the KSI gives you a short Bleep. The KSI is also supplied with the probe and power supply lead which are already made up, also a diagram is supplied.

A simple connection to the hole already on the Sinclair mainboard takes 5 minutes.

The keyboard sounder adds realism to the Sinclair ZX80 and also cuts eye fatigue. The total cost including p/p is only £15.

• Circle No. 205

SOFTWARE

Temple of Apshai (L2 16K TRS-80) £16.95
Courtball (L2 16K TRS-80) £5.95
Martial Invaders (Sorcerer) £11.95
Starbase Hyperion (Sorcerer 16K) £13.50
Screen Editor (Sorcerer) £8.95
Battleship Commander (32K Apple) £11.95
Wilderness Campaign (32K Apple) £10.95
Dungeon Campaign (48K Apple) £10.95
Pascal (16/32K NEW ROM Pet) £29.00
The B00K; Vol. 1 (TRS-80) £8.95
Supermap+ (TRS-80) £7.95

SPECIAL: £2 for 2 program cassette introducing our software's quality. State which version (Pet, Apple, L2 TRS-80, Sorcerer). Cassette is free with any order of more than £10 from list above. Many more programs available; ask for our catalogue. Written any programs? We pay good royalties. Trade inquiries invited.

Send cheque or P.O. to:
Dept. C3, Sapphire Software Ltd.
PO Box 244, Milton Keynes

• Circle No. 206

APPLE & ITT2020 BUSINESS SOFTWARE

Professionally written packages now available with comprehensive manuals, built-in validity checks, interactive enquiry facilities, user options, satisfying accountancy, inland Revenue and Customs & Excise requirements. On diskette under DOS 3.2, in Applesoft with SPACE utility. Not adaptations. Written for Apple System. Support all printer interfaces. Sales, Purchases and General Ledgers £295-00 each.

Manual only £3.
Payroll £375. Manual only £4.
General Ledger supports Incomplete Records, Job Costing, Branch and Consolidated Accounts etc.
General Ledger Applications Manual £10.
Prices exclusive of V.A.T. From our shop or your nearest stockist.

COMPUTECH SYSTEMS
168, Flinchley Road, London, N.W.3.
Tel: 01-794 0202

• Circle No. 207

(continued from previous page)

which were originally stored as separate programs on the disc. The purpose of the program was to have one subroutine on the disc which, although it could not be loaded on its own, was loaded at the end of several other programs.

The program works in the following way: the user gives the name of the main routine, the directory is then read from the disc and searched until the program is found. The program then goes to the routine of address which is given in the directory. The first two bytes found will either be a 0 followed by a number giving the number of bytes of program in that sector or there may be a track and sector number indicating that there is more of the routine on another sector.

The search continues until the last sector containing the routine is found. The end of the routine is marked by three bytes, @ @ @. They are removed and the rest of the sector is also cleared of any garbage left from previous programs — see example 2.

The user is then asked for the subroutine

name. It is found in the same way as the routine and its header changed from a direct loading routine to a continuation sector. The track and sector of the subroutine are taken and written into the last track and sector of the main routine. That will cause the subroutine to be pointed to during the loading of the main routine. The routine can be pointed to by more than one main routine thus saving disc space. The disc can be edited back to having separated programs if required using the Disc Debug program.

Although it is not possible to load the subroutine, edit it, re-save it and still ensure it is appended to the main routines, it is possible using the disc debug program to edit it directly on the disc. Just as errors can be overwritten, so minor edits may be performed using Disc Debug to input the special codes used by the Pet disc to represent Basic commands on the disc.

Disc Debug and Concat are available on a disc, price £14.95. Documentation only is £1.98 from the Technical Services Department of Intelligent Artefacts Limited.

Example 2.

The following program is shown in its Pet disc form:

```
10 FOR I = 1 TO 10
20 PRINT "EXAMPLE"
30 NEXT
40 END
```

Address	Hex	ASCII	Notes
00	00 20 01 04 0E 04 0A 00	0-ADNDJ0	
0F	81 20 49 B2 31 A4 31 30	↑ I+1_10	Start of Basic line
1E	00 10 04 14 00 99 22 45	@JDTG I" "E	
2D	58 41 40 50 40 45 22 00	XAMPLE" " "0	
3C	23 04 1E 00 82 00 29 04	#D^01000	
4B	28 00 80 00 00 00 2A 2A	(0-000)*	
5A	2A 2A 2A 2A 2A 2A 2A 2A	*****	Denotes end of routine
69	2A 2A 2A 2A 00 4F 0E 7A	****@0Nz	
78	03 8E 20 06 28 43 24 29	C' -(C#)	
87	B3 33 32 20 A7 20 43 24	+32 I C#	
96	B2 CA 28 46 53 24 20 33	+ (FS#, 3	
A5	AC 06 28 43 24 29 AA 31	-(C#) 11	
B4	20 33 29 3A 8E 00 70 0E	,3):/00N	
C3	84 03 8E 20 06 28 43 24	C' -(C#	
D2	29 B2 33 34 20 B0 20 06) +34 r -	
E1	28 43 24 29 B2 39 38 20	(C#)+98	

Garbage from previous programs

BUYERS' GUIDE

Software

Software packages are listed by application, in alphabetical order, with the systems on which each package will run also listed alphabetically. The guide is not exclusively for business applications: if your company is the source or dealer for a package with a more unusual application, send us the details and we will create a new category.

The usual criteria have been applied. The minimum configuration is 32K of RAM, a disc and a printer; the price of the package must lie between £50 and £1,000; the companies listed are the source of the software or the main dealers in the U.K., and the capacity quoted is per disc or drive.

Machine type by application

Combined-Ledger/Stock/Invoicing

Machine Type	Supplier Name	Price	Capacity
Apple II	Vlasak Electronics Ltd	£855	
Apple II/ITT 2020	Informex London Ltd	£298	500 A/Cs
Commodore 3032	Compfer Ltd	£400	varies
Commodore 3032	Bristol Software Factory	£300	1,000 A/Cs 6,000 trans
Commodore 3032	G W Computers Ltd	£275- £575	1,000



LINCOLNSHIRE APPLE DISTRIBUTORS

Stocks of Apples and most accessories Texas, Qume & Paper Tiger Printers 8" Discs, Corvus Disks for Apples.

SOFTWARE

Financial Planning Databases Mailing Visicalc Accounts Word Processing. Also the well known "Estate Computer Systems" Estate Agents Package in use throughout the U.K.

ESTATE COMPUTER SYSTEMS
30 Carre St., Sleaford, Lincs.
Tel: (0529-305637)

• Circle No. 208

TANDY TRS 80 FULL SALES & SERVICE IN BRADFORD

Printers	£
Microline 80	336.00
Microline 83	768.00
Epson MX80	360.00
Expansion	
Interface 32K	283.00
Teac Disk Drive	236.00
Twin Teac	440.00

DISKETTES

5 1/4" High quality diskettes	£19.20
8" High quality diskettes	£24.95

**EMERGENCY SERVICES AVAILABLE
FOR SYSTEM CRASHES**
All prices exclusive of VAT

BCS

**BRIARWOOD COMPUTER
SERVICES LIMITED**

Briarwood House, Preston Street,
Bradford, West Yorkshire, BD7 1NS.
Tel: (0274) 306018

• Circle No. 209

Software for CP/M Systems

- * Interpreters and compilers
- * Programming aids
- * Database management systems
- * Word processing

Write or 'phone for detailed catalogue:

Mike Lewis Consultants Ltd.
(ROOM 3) 48 WILLOUGHBY ROAD,
LONDON N.W.3.
TEL: 01-794 8838

• Circle No. 210

THORNGUARD LTD

The APPLE Agents for
the Wirral and North Wales
Memory and Micro Supplies

2114 450nS	2.20	Z80 CPU	6.85
2708 450nS	4.40	6502	6.95
2716 450nS	5.40	6800	4.50
4116 200nS	1.95	6802	6.80

Please add 15% VAT Postage & packing 30p

Barclaycard and Access Welcome

THORNGUARD LTD

144 IRBY ROAD, HESWALL, WIRRAL,
MERSEYSIDE L61 6XQ

Tel: 051-648 2162

• Circle No. 211

SUPERBRAINS

PRINTERS:

MICROLINE 80
EPSON MX80
NEC SPINWRITER

SOFTWARE:

M BASIC
WORD STAR
UCSD-P PASCAL

DISCOUNT PRICES
JAGOR TECHNICAL SYSTEMS
81 ATHERLEY ROAD

SOUTHAMPTON 20579

• Circle No. 212

DISKWISE

THE Apple Agents
in Devon & Cornwall
Present



Quality Software direct or from your
local Apple Dealer.

HOTEL PLAN — Hotel Management system
inc. booking & guest billing £475
TV RENTAL MANAGEMENT £395

TRADE ENQUIRIES WELCOME

DISKWISE

25 Fore St., Callington, Cornwall
Tel. 05793 3780

 apple computer
Sales and Service

• Circle No. 213

UK101 SOFTWARE ON TAPE

from the guy who wrote "La Passe Temps"

GALACTIC HITCHHIKER (8K) An Adventure, all in
machine code. A beauty! (£7.00)

SUPERTREK (8K) Sail boldly through the universe zap-
ping moving Klingons in real time. Superb graphics.
(£7.00)

LUNAR LANDER A real challenge. You won't get
down in less than three hours. (£3.00)

LE-PASS-TEMPS This is what a computer game
SHOULD be like (£3.00)

HANGMAN Excellent graphics... P.E. said so! (£3.00)

STARTREK (8K) The old favourite, beautifully
presented. Not real time but great graphics nonetheless
(£6.00)

* NEW *

MAD MONK (8K) An original graphics Adventure.
Something completely different for all the Hitchhiker
fans. (£7.00)

Others available include a BASIC TUTOR (8 x 4K
Programs) £12.00 and lots more games.

Each program comes on its own cassette by return 1st
Class Mail. Available for 16 x 48 or 32 x 48 display and
compatible all monitor ROMs. All inclusive from:

A. KNIGHT (DEPT PC)

28 SIMONDSIDE WALK, ORMESBY, CLEVELAND

Tel: (0642) 321266

• Circle No. 214

Commodore 3032	Analog Electronics	£550	
Commodore 3032	Stage One Computers	£600	varies
Commodore 3032	Logma Systems Design	£600	1-6 shops
Commodore 3032	Commodore B M (U.K.) Ltd	£650	650 A/Cs/ledger
Commodore 3032	Compter Ltd	£600	500 A/Cs 1,000 items
CP/M	Minicomputer CS Ltd	£650	varies
CP/M	Computastore Ltd	£1,000	
CP/M	Minicomputer CS Ltd	£850	varies
CP/M North Star	Benchmark CS Ltd	£950	200 A/Cs 500 trans 300 items
CP/M North Star	Profcomp Ltd	P.O.A.	
CP/M North Star	Intelligent Artefacts	£510	1,500 A/Cs 5,000 trans
CP/M North Star	Instar Business Systems	£999	600-2,900
Metrotech System	Metrotech	£500-- £1,000	
Ohio Scientific	Microcomputer B M	£656	
Tandy TRS-80	Microcomputer Applications	£90 each	
Tandy TRS-80	T & V Johnson Ltd	£110	750 trans/disc
Tandy TRS-80	Microcomputers Applications	£350	
TECS	Jar Software Systems	£650	500 A/Cs 300 nom A/Cs
Z-80/8080	Graffcom Systems Ltd	£995	
Z-80/8080	Great Northern C S Ltd	£995	varies

General Ledger

Machine Type	Supplier Name	Price	Capacity
Apple II	Vlasak Electronics Ltd	£225	200 A/Cs 1,000 trans
Apple II	Computech Systems	£295	500 A/Cs 1,700 trans
Apple II/ITT 2020	Systematics International Ltd	P.O.A.	
Commodore 3032	Analog Electronics	£450	
Commodore 3032	HB Computers Ltd	£200	Linked to S/L & P/L
Commodore 3032	Bristol Software Factory	£300	1,000 A/Cs 6,000 trans
CP/M	Haywood Associates Ltd	£500	
CP/M	Median-Tec Ltd	£500	500 A/Cs 600 trans
CP/M	Computastore Ltd	£500	999 A/Cs 99 centres nine companies
CP/M	Ludhouse Ltd	£500	200 A/Cs 5,000 trans
CP/M	Comput-A-Crop	£400	
CP/M	Benchmark CS Ltd	£250	500 A/Cs 5,700 trans
SD100/200	Barcellos Ltd	£250	
Tandy TRS-80	Tridata Micros Ltd	£225-- £375	500 A/Cs 1,000 trans
Z-80/8080	Great Northern C S Ltd	£275	varies
Z-80/8080	Graffcom Systems Ltd	£390	

Incomplete Records

Machine Type	Supplier Name	Price	Capacity
Apple II	Personal Computers Ltd	£250	1,000 trans 2,600 A/Cs
Apple II/ITT 2020	Padmede Computer Services	£450	900 A/Cs 2,000 trans/disc
Commodore 3032	Stage One Computers	£750	500 centres 2,300 A/Cs
Commodore 3032	Micro Computation	£555	120 A/Cs 5,000 trans
CP/M	Profcomp Ltd	P.O.A.	2,000 entries
Durango F85	Kesho Systems	£1,000	
Exidy Sorcerer	Basic Computing	£350 incl.	see also Micropute



Job Costing/Billing

Machine Type	Supplier Name	Price	Capacity
Apple II/ITT 2020	Padmede Computer Services	£300	1,000 A/Cs 99 centres
Apple II/ITT 2020	Padmede Computer Services	£300	150 A/Cs
Commodore 3032	Stage One Computers	£100	300 appointments
Commodore 3032	CSM Ltd	£600	1,000 jobs 100 people
CP/M	Graffcom Systems Ltd.	P.O.A.	100 activity codes
Z-80/8080	Great Northern C S Ltd	£300	varies

Mailing Systems

Machine Type	Supplier Name	Price	Capacity
Apple II	Keen Computers Ltd	£300	500 addresses
Apple II/ITT 2020	Systematics International Ltd	£300	500 addresses
Apple II/ITT 2020	Guestel Ltd	£190	400 addresses
Apple II/ITT 2020	The Software House	£57	750 names & adds
Commodore 3032	Stage One Computers	£100	350 records
Commodore 3032	MMS Computer Systems	£250	3,000 records
CP/M	Graffcom Systems Ltd	£250	varies
CP/M	Median-Tec Ltd	£500	
CP/M	Structured Systems Group	£50	varies
CP/M Horizon	Microtek Computer Services	£500	varies
CP/M North Star	Micromedia Systems	£195	
Tandy TRS-80	Comput-A-Crop	£78	varies
Tandy TRS-80	Cleartone ADP	£50	660 entries
Tandy TRS-80	T & V Johnson Ltd	P.O.A.	3,000 names/addresses
Z-80/8080	Micro Focus	£90	varies
Z-80/8080	Intereurope S D Ltd	£500	3,000 entries

Payroll

Machine Type	Supplier Name	Price	Capacity
Apple II/ITT 2020	T W Computers Ltd	£145	
Apple II/ITT 2020	Informex London Ltd	£50	
Apple II/ITT 2020	Informex London Ltd	£198	200 employees
Apple II/ITT 2020	Algobel Computers Ltd	£295	500 employees
Apple II/ITT 2020	Vlasak Electronics Ltd	£360	
Apple II/ITT 2020	Minster Micro System	£199	100 month 50 weekly
Apple II/ITT 2020	Computech Systems	£379	300 employees
Commodore	Petsoft Ltd	£50	200 employees
Commodore 3032	Landsler Software	£95 incl.	200 employees
Commodore 3032	Commodore B M (U.K.) Ltd	£150	200 employees
Commodore 3032	Analog Electronics	£90	
Commodore 3032	ACT (Petsoft) Ltd	£195	600 employees
Commodore 3032	L & J Computers	£220	
Commodore 3032	Intex Datalog Ltd	£195	200 employees
Commodore 3032	Computastore Ltd	£200 & £350	275 & 500 employees
CP/M	Haywood Associates Ltd	£350	
CP/M	Median-Tec Ltd	£500	
CP/M	Selven Ltd	P.O.A.	
CP/M	Graffcom Systems Ltd	£500	250 employees
CP/M	PCL Software Ltd	£600	800 employees/MBYTE
CP/M	Ludhouse Ltd	£450	300 employees
CP/M	Comput-A-Crop	£450	
CP/M Horizon	Microtek Computer Services	Lease	varies
CP/M North Star	Micromedia Systems	£495	350 employees
Durango F-85	Kesho Systems	£500	
Sharp MZ-80K	Tridata Micros Ltd	£250	400 employees
Tandy TRS-80	A J Harding (Molimerx)	£95-£200	
Tandy TRS-80	Tridata Micros Ltd	£218- £375	400 employees
Tandy TRS-80	3-Line Computing	£140	
TECS	Jar Software Systems	£250	300 employees

Limited Offer COMPLETE FUNCTIONAL BUSINESS SYSTEM

£2775.00

+ VAT No Extras

INCLUDES FULLY INTEGRATED Very Comprehensive Business Software. INTEGRATION Includes: Automatic Update of STOCK, INVOICE, V.A.T, DEBTORS, CREDITORS, BANK, ADDRESSES, STATEMENTS, MAILING LIST etc. etc. FULL Reporting Facilities e.g. Up to 30 on Sales Ledger. Any record retrieved within a second User Alterable Vocabulary. The Programme is stored in memory Releasing Both Disks for Data Storage. Power failure only means loss of actual entry you are working on. The System does not require pre-printed stationery.

ALSO INCLUDES THE FOLLOWING
The INTERTEC SUPERBRAIN 64K. Twin 280's. 320K Disks. Housed in one Desktop unit. Leader in Performance-Price Field.

THE OKI MICROLINE 80 Printer. Quiet and Dependable. INTERFACE For The Ok.

Set Of Manuals.

DON'T FORGET. THIS SYSTEM IS COMPLETE & REQUIRES NO EXTRAS OR SOFTWARE.

Finance Available.

Also available our unique Functional Business Software for

TRS 80 16K LII

with fast data transfer on cassette, some examples

BANK A/C PROGRAMME

22 Column analysis, self totalling on all columns. Keeps full alpha & numeric records. At command shows 17 monthly & yearly Totals to date, including Partners drawings, Total O'heads etc. £21.95

SALES LEDGER

Full record up to 17 headings for each invoice. Totals 8 columns, searches & totals individual accounts at will, also weeks sales, months individual heading totals, agents sales & displays entire records page by page. £21.95

MAILING LIST

Searches by Name, Town, County & code no. which can be used to create your own reference system. Search by name Does Not Require Exact Spelling To Find. £9.95 All programs are menu driven needing no operator expertise. Most responses require only single keystrokes. Operator errors are correctable. Custom Software.

TYPER III "Mini Wordprocessor" £12.95

Use your Tandy as a Typewriter but have some of the facilities of a Wordprocessor. No need for a carriage return, Automatic Paragraphs, Right Justification, Screen Display & Correction During Typing, Choice of three Print Sizes etc. Manual Incl. Runs on OKI. Easily adaptable for other printers.

OKI Micro Line 80 £315.00.

NEW! New range of Terrific Games. Written to a High Standard from £5-£7.50. All Original. PGP plus .75 pence.

Quality Plain LISTING PAPER 9 1/2" x 11"

2000 Sheets £14.00 + £2.55 p&p

Quality 4 PART FORMS 8 1/2" x 11"

500 SETS £17.28 + £2.55 p&p

ACCESS COMPUTERS

2 Rose Yard, Maidstone, Kent, ME15 1HN.

Tel: Maid. (0622) 58356

• Circle No. 215

THE ATOM MAGIC BOOK

£5.50

A wealth of games and other programs plus much useful software and hardware information. A 'must' for every Acorn Atom user.

THE ZX80 MAGIC BOOK

£4.75

Games programs, hardware and software information, and circuits for static and dynamic RAM and I/O extensions.

MAKING THE MOST OF YOUR ZX80

£5.95

Tim Hartnell's superb book on writing games programs for the ZX80, with many many examples.

1KZX80 Moving Display Programs on Cassette!!!

No flicker, no fuss. S.a.e. for details.

TIMEDATA Ltd. 57 Swallowdale, Basildon, Essex

• Circle No. 216



APPLE DEALER
FOR
PETERSFIELD & PORTSMOUTH



WILL DEMONSTRATE
COLOUR GRAPHICS
DATA BASE/MAILING LIST
TABS ACCOUNTING SYSTEM

FOR SALES & SERVICE:
ACCESS CONTROL SYSTEMS LTD.
72 WINCHESTER ROAD,
PETERSFIELD, HANTS GU32 3PW
Tel: Petersfield (0730) 5274



• Circle No. 217

Business Systems
Systems Development

Programs designed
and written for North Star
and CP/M computer systems

Consultancy

- Feasibility studies
- Independent advice
- Project management
- Single source supply of complete systems.

We specialise in accounting,
order processing, invoicing
and stock control systems.

McMillan Computing Services
3 Tithebarn Grove
Calcot, Reading
Tel: 0734 414751

• Circle No. 218

**TRS 80
LIGHT PEN**

The most versatile and inexpensive peripheral for your TRS 80 or Video Genie.

- The Photopen package includes:
- A fully assembled Photopen
 - A cassette of four programs
 - Four pages of instructions
 - A 9v battery

The Photopen connects to your system via the cassette recorder and requires no modifications to your system. Full details of programming in Level 2 Basic are given using a simple subroutine in your own programs. Video Genie users require second cassette recorder. The Photopen will work with any TV or monitor.

Price only **£14.99 + 50p p&p.**

Business software for minimal 16K Level 2 TRS 80

- CSL Database Manager £9.50
- CSL Inventory Manager £13.50
- CSL Videopad Suite £15.50

CSL MICRODATA
4 GREENBARN WAY, BLACKROD, LANCASHIRE
BL6 5TA
Tel. 0204 694265

• Circle No. 219

Z-80/8080	Graffcom Systems Ltd	£490	250 employees
Z-80/8080	Livport Data Products	£250	500 employees

Property Management

Machine Type	Supplier Name	Price	Capacity
Apple II/ITT 2020	Cyderpress Ltd	£650	500 properties; 420 applicants
Apple II/ITT 2020	Informex London Ltd	£298	300 entries
Apple II/ITT 2020	Algobel Computers Ltd	£650	400 buildings 250 Own 2,000 trans
CP/M	Algobel Computers Ltd	£650	2,000 trans
Z-80/8080	Graham Dorian Software	£325	varies

Purchase Ledger

Machine Type	Supplier Name	Price	Capacity
Apple II	Vlasak Electronics Ltd	£315	200 A/Cs 1,000 trans
Apple II	Computech Systems	£295	500 A/Cs 1,600 trans
Apple II/III 2020	Padmede Computer Services	£300	900 A/Cs 4,500 trans/disc
Apple II/III 2020	Systematics International Ltd	P.O.A.	
Commodore 3032	Microact Ltd	£350	2,000 A/Cs 7,000 trans
Commodore 3032	HB Computers Ltd	£350	800 A/Cs, 4,000 trans
Commodore 3032	Compler Ltd	£300	1,000 A/Cs 7,000 entries
Commodore 3032	ACT (Petsoft) Ltd	£120	200 A/Cs 700 trans
CP/M	Haywood Associates Ltd	£350	
CP/M	Median-Tec Ltd	£500	500 A/Cs 600 trans/ACs
CP/M	Structured Systems Group	£460	varies
CP/M	Ludhque Ltd	£500	500 A/Cs 5,000 trans
CP/M	Comput-A-Crop	£400	500 A/Cs
CP/M	Computastore Ltd	£400	500 A/Cs 3,100 trans
CP/M North Star	Benchmark CS Ltd	£250	500 A/Cs 2,000 trans
Durango F-85	Kesho Systems	£500	
Exidy Sorcerer	Basic Computing	£125 incl	See also Micropute
SD-100/200	Barcellos Ltd	£250	
Tandy TRS-80	AJ Harding (Molimerx)	£225	1,100 entries
Tandy TRS-80	Tridata Micros Ltd	£225	
		£375	125 A/Cs 1,000 trans
Z-80/8080	Great Northern CS Ltd	£275	varies
Z-80/8080	Graffcom Systems Ltd	£440	

Records Management

Machine Type	Supplier Name	Price	Capacity
Apple II	Courtman Micro Systems	£106	100K Characters
Apple II/ITT 2020	Diskdean Ltd	£120	varies
Apple II/ITT 2020	Systematics International Ltd	£125	1,000 references
Apple II/ITT 2020	Informex London Ltd	£198	500-1,200 records
Apple II/ITT 2020	T & V Johnson Ltd	£95	112K per drive
Apple II/ITT 2020	Systematics Intl Ltd	£72 & £175	
Apple/ITT 2020	The Software House	£140	900 records
Commodore 3032	CPS (Data Systems) Ltd	£200	varies
Commodore 3032	Amplicon MS Ltd	£140	1,500 records
Commodore 3032	Compsoft Ltd	£95-£170	600-5,000 records
Commodore 3032	Microact Ltd	P.O.A.	400K-800K
Commodore 3032	Commodore BM (U.K.) Ltd	£150	650
Commodore Pet	Stage One Computers	£130-£250	165K



CP/M	Clenlo Computing Services	£90-£325	varies
CP/M	Median-Tec Ltd	£500	
CP/M SWTPC	Verwood Systems		
Metrotech System	Metrotech	£200- £1,000	
Ohio Challenger	U-Microcomputers Ltd	£175+	
Ohio Scientific	Microcomputer BM	£175	
SD-100/200	Barcellos Ltd	£500- £1,000	
Tandy TRS-80	T & V Johnson Ltd	£200	
Z-80/8080	Structured Systems Group	£135	varies
Z-80/Cromenco	Xitan Systems Ltd	£850	4,000 records/disc

Sales Ledger

Machine Type	Supplier Name	Price	Capacity
Apple II	Vlasak Electronics Ltd	£315	200 A/Cs 1,000 trans
Apple II	Computech Systems	£295	500 A/Cs 1,600 trans
Apple II/ITT 2020	Padmede Computer Services	£300	900 A/Cs 4,500 trans/disc
Apple II/ITT 2020	Systematics International Ltd	P.O.A.	
Commodore 3032	Microact Ltd	£350	2,000 A/Cs 7,000 trans
Commodore 3032	Anagram Systems	£320	500 A/Cs
Commodore 3032	ACT (Petsoft) Ltd	£120	200 A/Cs 700 trans
Commodore 3032	HB Computers Ltd	£350	800 A/Cs 600 trans/ACs
CP/M	Median-Tec Ltd	£500	500 A/Cs 600 trans/ACs
CP/M	PCL Software Ltd	£500	1,000 A/Cs/MByte
CP/M	Ludhouse Ltd	£500	1,000 A/Cs 5,000 trans
CP/M	Ludhouse Ltd	£1,000	
CP/M	Computastore Ltd	£400	500 A/Cs 3,500 trans
CP/M	Haywood Associates Ltd	£350	
CP/M North Star	Benchmark CS Ltd	£250	500 A/Cs 2,000 trans
Durango F-85	Kesho Systems	£500	
Exidy Sorcerer	Basic Computing	£125 incl.	See also Micropute
SD-100/200	Barcellos Ltd	£250	
Tandy TRS-80	Tridata Micros Ltd	£225- £325	175 A/Cs 1,350 trans
Tandy TRS-80	AJ Harding (Molimerx)	£225	1,350 entries
TECS	Jar Software Systems Ltd	£550	500 A/Cs
Z-80/8080	Graffcom Systems Ltd	£440	
Z-80/8080	Great Northern CS Ltd	£275	varies

Stock Systems

Machine Type	Supplier Name	Price	Capacity
Apple II/ITT 2020	Microdigital Ltd	£225	625 items
Apple II/ITT 2020	Systematics Intl Ltd	£500	200-2,500 items
Apple II/ITT 2020	Vlasak Electronics Ltd	£285	
Apple/ITT 2020	The Software House	£80	800 items
Commodore 3032	SMG Microcomputers	£395- £495	2,450-7,000 items
Commodore 3032	Logma Systems Design	£600	1-6 shops
Commodore 3032	L & J Computers	£230	
Commodore 3032	ACT (Petsoft) Ltd	£75	2,400 items 1,000 A/Cs
Commodore 3032	Compfer Ltd	£350	200 lines 20 bars
Commodore 3032	Microact Ltd	£350	2,500 items, 1,000 A/Cs
Commodore 3032	Bristol Software Factory	£300- £360	2,300



Lots of **11Z-80K**s and **PC1211s** for **IMMEDIATE** delivery. We try to match best prices anywhere!!!

King Pin Computers

PO BOX 40 — STEVENAGE —
HERTS SG1 2NA
TEL: STEVENAGE (0438) 59677

• Circle No. 220

AT LAST!

A book that doesn't pretend to teach you about the ZX80. Just page after page of great



new games, plus some exciting adaptations of a few old favourites.



ONLY £4.95 incl. p&p

ZX80 INVADERS £6.95*



GALAXY WARS £6.95*

Both of these incredible games are written by John Edmonds, and contain his Genuine Moving, Completely Flicker-free Graphics Display! Both cassettes are supplied to fit 4K machines. Documentation enclosed. NOW IN STOCK. 1K SUPAPACKS ALPHA, BETA, GAMMA & DELTA at £4.95* each.

4K WUNDAPACK ONE at £6.95* AND NOW, 4K WUNDAPACK TWO, contains: - ZX80 YAHTZEE; LEAGUE CHAMPIONSHIP; BLACK-JACK (Full graphics) + HEADS WILL ROLL (Cricket with a difference) only £5.95*

*Incl. VAT & P + P Send large S.A.E. for catalogue. Make Cheques/P.O. payable to: -

SYNTAX SOFTWARE
DEPT PC4
96 COLLINWOOD GARDENS,
GANTS HILL, ILFORD ESSEX.

• Circle No. 221

SPECIAL CARDS FOR APPLES

Do you want to connect an **APPLE** to the **OUTSIDE WORLD**? We can make this possible by designing and building **BOARDS CARDS SYSTEMS** to suit your needs

Contact:
MR P. HERBERT
DAWSON SHANAHAN LIMITED
01-440 9372/3/4/5

• Circle No. 222

?MICRO PROBLEMS?

- Time ledger package — for time, expenses and sales recording by project
- Fully integrated sales purchase and nominal ledger packages
- Customised Software
- Consultancy and Training
- APPLE II and most micros covered

DELTA COMPUTING

MAY PLACE HOUSE, MAY PLACE,
BASINGSTOKE, HANTS. RG21 1NX
(0256) 59715 Telex: 858151

• Circle No. 223

EXCEPTIONAL OPPORTUNITY

Basic Programmer

REQUIRED

To run his own Micro Software House on our premises. We provide a telephone, office, a Superbrain Micro and masses of work.

CONTACT

ATLANTIC MICRO SYSTEMS

70-72 HONOR OAK PARK SE23
TEL: 01-699 2202

• Circle No. 224

FALCON SOFTWARE

89 ALLERTON GRANGE WAY LEEDS LS17 6LR

PC-1211 HYPERPACK 1 £8

• CESIL INTERPRETER • SUBHUNT • DALLAS • CAPACITOR COLOUR CODES • MATHS QUIZ • BATTER THE BURTLE • SAILING.

PC-1211 HYPERPACK 2 £8

• MORSE CODE • MASS CONVERSION • MODULO MATHS • PARACHUTING • MASTERMIND • EMPIRICAL FORMULAE • BATTLESHIPS. BOTH PACKS ORDERED TOGETHER — £12.

TRS-80 LEVEL II 16K £8

• PROJECTILES • WAVES. More under development. S.A.E. for details on ZX-80/ZX-81 software. 1K and 16K.

WE GUARANTEE NO LOADING/SAVING PROBLEMS
PC-1211 PACKS HAVE FREE LEAFLET ON HOW TO INCREASE TO 1936 STEPS!!! CHEQUES/P.O.'s PAYABLE TO PC/1211 USERS' CLUB.

ALLOW 21 DAYS FOR DELIVERY

• Circle No. 225

Apple-II in Scotland Core Data Systems Ltd

Suppliers of APPLE hardware and software.

We offer advice on the use of micro-computer systems, and undertake the design of systems to client's specifications.

Specialists in UCSD Pascal.

Now in new premises at:

101 COLINTON ROAD
EDINBURGH EH14 1AL
Phone 031-443 8710

Authorised APPLE Service Centre

• Circle No. 226

Commodore 3032	Commodore B M (U.K.) Ltd	£150	650
Commodore 3032	Anagram Systems	£395	500-600 items 255 A/Cs
Commodore 3032	SA Systems	£650	300 records/disc
Commodore 3032	Petsoft Ltd	£50	2,500 items
Commodore 3032	L & J Computers	£60	500 items
Commodore 3032	Rockliff Brothers Ltd	£120	3,900 items
Commodore 3032	Stage One Computers	£100	650 items
CP/M	Haywood Associates Ltd	£350	
CP/M	Median-Tec Ltd	£500-£800	
CP/M	Graffcom Systems Ltd	£350	520-6,000 items
CP/M Cromemco	Micromedia Systems	£1,000	
CPM/Horizon	Microtek Computer Services	£1,000	varies
CP/M North Star	Benchmark CS Ltd	£450	1,000 items 750 trans
Exidy Sorcerer	Basic Computing	£125 Incl	See also Micropute
Tandy TRS-80	Microgems Software	£150	1,000-2,000 items
Tandy TRS-80	A J Harding (Molimerx)	£225	630 items
Tandy TRS-80	Clearstone ADP	P.O.A.	
Tandy TRS-80	S A Systems	£650	300 stock records
Tandy TRS-80	T & V Johnson Ltd	£115	1,000 items
Tandy TRS-80	T & V Johnson Ltd	£145	1,000 items/invoices
Tandy TRS-80	Tridata Micros Ltd	£200-£375	630 items/disc
TECS	Jar Software Systems	£800	10,000 items 5,000 orders
TECS	Jar Software Systems	£850	1,000 items 300 A/Cs
Z-80/8080	Graham Dorian Software	£325	varies
Z-80/8080	Rogis Systems Ltd	£500	900-3,500 items
Z-80/8080	Great Northern C.S. Ltd	£275	varies
Z-80/8080	Graffcom Systems Ltd	£340	
Z-80/8080	Graffcom Systems Ltd	£580	
Z-80/MCZ	Software Architects Ltd	£600	varies

Word Processing

Machine Type	Supplier Name	Price	Capacity
Apple II	Personal Computers Ltd	£150	17 A4 pages
Apple II/ITT 2020	Vlasak Electronics Ltd	£120	
Apple II/ITT 2020	Systematics International Ltd	£75	
Apple II/ITT 2020	Guestel Ltd	£190	100K characters
Apple II/ITT 2020	Algobel Computers Ltd	£75	800 lines
Commodore 3032	Act (Petsoft) Ltd	£325	12,000 bytes
Commodore 3032	Act (Petsoft) Ltd	£325	12K bytes
Commodore 3032	Dataview Ltd	£159	
Commodore 3032	HB Computers Ltd	£70	39 A4 pages
Commodore 3032	Commodore BM (U.K.) Ltd	£75 & £150	170 pages
Commodore 3032	Stage One Computers	£100	130 pages
CP/M	Median-Tec Ltd	£300	
CP/M	Computastore Ltd	£400	
CP/M	Southdata Ltd	£350	160,000 words
CP/M North Star	Micromedia Systems	£495	
Ohio Scientific	Microcomputer B M	£116	
Tandy TRS-80	T & V Johnson Ltd	£109	10,000 words
Z-80/8080	Structured Systems Group	£120	varies
Z-80/8080	Intereurope S D Ltd	£500	varies

There is an increasing number of packages which do not fit into any of the standard categories we have created and so we have consequently listed them under the title Miscellaneous. They appear in alphabetical order by machine type. The names of

similar packages can be very different so users of the guide should check every entry under their machine type. The full address of the supplier can be found at the end of the guide.

Miscellaneous applications for all machine types

Machine Type	Application and Supplier Name	Price	Capacity
Apple II/ITT 2020	Auction system Cyderpress Ltd	£650	400 entries
Apple II	Cashflow/Bank forecast Vlasak Electronics Ltd	£80	
Apple II	Credit control Microdigital Ltd	£130	
Apple II/ITT 2020	Employment Agents' system Informex London Ltd	£298	600 entries
Apple II/ITT 2020	Estate Agents' system Cyderpress Ltd	£650	280 properties 360 applicants
Apple II/ITT 2020	Estate Agents' system Systematics International Ltd	£850	
Apple II	Estate Agents' register Vlasak Electronics Ltd	£120	
Apple II/ITT 2020	Financial planning Systematics International Ltd	£295	
Apple II	3D graphics package Fylde Microcomputer Services	£150	
Apple II/ITT 2020	Hospital administration Informex London Ltd	£198	300-600 records
Apple II/ITT 2020	Insurance records Informex London Ltd	£198	600 records
Apple II	Letter writer Vlasak Electronics Ltd	£80	
Apple II/ITT 2020	Medical records Informex London Ltd	£198	300-600 records
Apple II/ITT 2020	Modelling, VisiCalc Microsense Computers Ltd	£95	Variable
Apple II/ITT 2020	Pipeline engineering Aerco-Gemsoft	£175	
Apple II/ITT 2020	Property/Estate system Cyderpress Ltd	£650	500 properties 420 applicants
Apple II/ITT 2020	Property/Estate Agents' Informex London Ltd	£298	300 entries
Apple II/ITT 2020	Property valuation Cyderpress Ltd	£650	
Apple II	Sales analysis Microdigital Ltd	£200	500 A/Cs
Apple II	Structural engineering design James C Steadman	£200	
Apple II/ITT 2020	Time recording—solicitors' Informex London Ltd	£198	300 clients
Apple II/ITT 2020	TV rental management system Diskwise Ltd	£395	
Commodore 3032	Appointments planner Commodore BM (U.K.) Ltd	£50	200 entries
Commodore 3032	Bank account reconciliation Stage One Computers	£100	
Commodore 3032	Building conversion Micro Computation	£300- £400	320 clauses
Commodore 3032	Cash book L & J Computers	£90	
Commodore 3032	Estate Agents' package Stage One Computers	£250	325 properties



Cranfield SCHOOL OF ELECTRONIC SYSTEM DESIGN

MODERN TECHNIQUES IN ELECTRONIC SIGNAL PROCESSING

An introductory course covering
**DIGITAL FILTERS, FFTs
MICROCOMPUTERS
CCD AND SAW DEVICES**
11-15 MAY

**ELECTRONICS FOR
MECHANICAL ENGINEERS**
27 APRIL-3 JULY
May be taken in modules

**SOFTWARE ENGINEERING AND
DESIGN MANAGEMENT**
15-19 JUNE NEW 81

Closed courses can be arranged for a Company at Cranfield or elsewhere.

Further details from:
Short Course Office,
Cranfield Institute of Technology
Bedford MK43 0AL,
Bedford (0234) 750111. Exct. 284

• Circle No. 227

The better CP/M Word Processing system —

MAGIC WAND

We now have in stock the latest version (1.1), with many new features. MAGIC WAND is easy and quick to learn, and includes facilities to merge data from external files. We can tailor the system to use the function keys on your VDU. Available in 8" or North Star formats. Please specify VDU and printer types when ordering.

£190.00 plus VAT

Roundhill Computer Systems Ltd
PO BOX 14
MARLBOROUGH, WILTS. SN1 1LG
TELEPHONE 0672 54459



• Circle No. 228

sinclair ZX80 Programming Course Second edition

There are now many books concerning the ZX80 around, and you are probably wondering which to buy. This book is not just a book of programs - it sets out to improve YOUR programming skills with minimum effort on your part. It does not leave you with the task of typing in all the programs yourself; many are on the accompanying cassette - simply LOAD them and RUN. This gives you more time to learn about them. The book is easy to read and deals with arrays, FEEK, POKE, USR and machine code, flowcharts etc.etc. The complete course consisting of book & cassette, costs just ~~£8.95~~ inclusive, and when you order it, you will receive:-

FREE! complete catalogue of ZX80 software.
FREE! program listing for noughts & crosses - fits in UK.
FREE! voucher giving you 5% off your next order of ZX80 software.

251 HENLEY ROAD COVENTRY

BUG-BYTE

• Circle No. 229

ALGOL-60 Z80-CP/M, PDP11, PDP8

A family of high level languages
from RHA (Minisystems) Ltd.

ALGOL-60, the language from which PASCAL is derived. A mature implementation with comprehensive operating system and machine code interfaces.

SYSTEJ-ALGOL, the subset of Algol-60 in which all the compilers are written. Compiled code is shorter, execution faster.

Z80 based CP/M systems including TRS80 RML Algol-60, includes the option of 32 bit integers instead of floating point. About 7 times faster than TRS80 level II BASIC, speed comparable with Microsoft Fortran. Document £10, system £99 + VAT. System-Algol £50 + VAT, free leaflet.

PDP11 WITH RT-11, RSTS, RSX or IAS and PDP8 with OS/8 or stand alone

Complete package including both compilers in machine readable source form... £250 + VAT consultant.

83, Gidley Way, Horspath, Oxford OX9 1TQ (08677) 3625

• Circle No. 230

LOOK

The latest version of the famous

EPSON TX-80

The TOPPER with GRAFTRAX



This unique option from DATAPLUS gives the TX-80 a FULL HI-DEF GRAPHICS capability. When the bit plot mode is invoked, each bit arriving via the parallel interface individually controls one of the 7 print head needles.

Additional facilities include software control of line feeds in .007" increments, and many others. You have NEVER been offered a better deal than this.

TX-80 with parallel interface..... £355 + VAT
GRAFTRAX option..... £4.50 + VAT

Apple, PET, Sharp, Tandy
RS.232 Interfaces..... £ 40 + VAT

Cash or Credit Cards accepted.

DATAPLUS LTD.

39-49 Roman Road, Cheltenham,
0242-30030 or 37373.

• Circle No. 231

SORT OUT YOUR CAT APPLE AND ITT SOFTWARE

CATSORT* Sorts Disk Catalogue into Alpha Order.
Apple/Palsoft and Machine Code. Req 32K..... £10
CATINDEX* Auto. Index of Disks keeps Alpha Order list
Full Search edit Fac. Apple/Palsoft and Machine
Code Reqs 24K..... £12

CUSDOS* Customise your Dos commands. Change
"Catalog" to "Cat" etc.
Apple/Palsoft and Machine Code..... £10

MORTGAGE AND INVESTMENT ANALYSIS — Several
features incl. mortgage Repayment table. Apple/
Palsoft Reqs 16K..... £20

SHAPER Plot Hires Shapes in Hires and save shape
table on disk or cassette. Apple/Palsoft. Reqs 16K.
£7.50

TELNOS* Personal file of name, address, post code,
tel no and exchange Search any field. Apple/
Palsoft. Reqs 24K..... £ 8

FINDER* Your own personal library index. Facilities to
find mag. articles in seconds. Reqs 24K..... £10

PLOT-A-SKETCH Hires drawing like you know what.
Uses paddles or keys — state option. Apple/
Palsoft. Reqs 16K..... £6.50

CLOCK 12 hr digital clock in machine code..... £ 5

MORSE Morse Code send and rec. Interface details
supplied. Apple/Palsoft and Machine Code. Reqs 8K.
£25

* Supplied on Disk and reqs Disk Drive.
Others supplied on Cassette — Disk £5 extra.

G.A. HUNTINGTON,
176 STRINES ROAD, STRINES, STOCKPORT,
CHESHIRE, SK12 3AA.

• Circle No. 232

Commodore 3032	Financial planning ACT (Petsoft) Ltd	£150	Varies
Commodore 3032	Hotel room system Landsler Software	£430	200 rooms
Commodore 3032	Hotel system and billing Landsler Software	£295	280 rooms
Commodore 3032	Insurance Brokers' system Stage One Computers	£100	
Commodore 3032	Invoicing/Costing—jewellers' CPS (Data Systems) Ltd	£575	
Commodore 3032	Job/Appointments planner Stage One Computers	£100	300 appointments
Commodore 3032	Machine hire L & J Computers	£420	
Commodore 3032	Order control MMS Computer Systems	£250	3,600 orders
Commodore 3032	Printers' job control Stage One Computers	£450	130 jobs/disc
Commodore 3032	Printers' quote system Microland	£175	
Commodore 3032	Sales analysis Logma Systems Design	£600	1-6 shops
Commodore 3032	Service company package Stage One Computers	£1,000	
Commodore 3032	Stock/farming livestock S.A. Systems	£650	300 records/disc
Commodore 3032	Window replacement CSM Ltd	£500	
Commodore 3032	Work measurement The Alphabet Company	£150	
CP/M	Cashflow forecasting Ludhouse Ltd	£250	
CP/M	Financial analysis Median-Tec Ltd	£500	
CP/M	Hire purchase system Graffcom Systems Ltd	P.O.A.	Depends on system
CP/M	Invoice discount/factoring Micromedia Systems	£1,000	
CP/M	Order entry & invoicing Graffcom Systems Ltd	£350	500-5,000 orders
CP/M various	P & L budgeting system Micromedia Systems	£495	
CP/M North Star	Personnel records Micromedia Systems	£595	
CP/M	Purchasing system Graffcom Systems Ltd	£450	540-7,000 invoices
CP/M	Statistical analysis Research Resources Ltd	£240 pa	
CP/M	Time recording Haywood Associates Ltd	£500	
CP/M North Star	Vehicle maintenance Micromedia Systems	£195	
Tandy TRS-80	Financial analysis A J Harding (Molimerx)	£55	
Tandy TRS-80	Invoicing Tridata Micros Ltd	£75-150	Linked to stock and sales
Tecs	Production analysis Jar Software Systems	£600	1,000 products 2,500 items
Durango F-85	Time recording/ledger Kesho Systems	£1,000	
Z-80/8080	Appointments system Great Northern CS Ltd	£220-275	Depends on system
Z-80/8080	Civil/structural engineering design Equinox Computer Systems	£500	varies
Z-80/8080	Conference organiser Intereurope SD Ltd	£500	30,000 entries
Z-80/8080	Financial modelling Intereurope SD Ltd	£500	1,000 items 100 reports
Z-80/8080	Personnel records Intereurope S D Ltd	£500	200-300 items

Z-80/8080

Sales analysis retail
Graham Dorian Software

£325

Depends on system

Alphabetical list of suppliers

Supplier	Address	Sales contact
3-Line Computing 0482-445496	36 Clough Road Hull HU5 1QL	Tim Hill
Minster Micro Systems 04254-4751	88 Christchurch Road Ringwood, Hampshire, BH24 1DR	R Kilpatrick
ACT (Petsoft) Ltd 021-454-5341	Radclyffe House 66-68 Hagley Road, Edgbaston Birmingham	M Wauchope
Aerco-Gemsoft 04862-22881	27 Chobham Road Woking, Surrey GU21 1JD	Nigel Tylor
A J Harding (Molimerx) 0424-22039	28 Collington Avenue Bexhill-on-Sea, East Sussex	John Harding
Algobel Computers Ltd 021-233-2407	33 Cornwall Buildings Newhall Street, Birmingham B3 3QR	Steven Linden
Amplicon M S Ltd 0273-562163	143A Ditchling Road Brighton, Sussex BN1 6JA	Jim Hicks
Anagram Systems 0403-68601	9 Michell Close Horsham, West Sussex RH12 1JT	Jon Quigly
Analog Electronics 0203-417761	47 Ridgeway Avenue Coventry	
Barcellos Ltd Leicester 26584/5	Kimberley House Vaughan Way, Leicester	K Tapp
Basic Computing 0535-65094	Oakworth Road Keighley, West Yorkshire BD22 7LA	Mike Collier
Benchmark CS Ltd 0726-61000	Tremena Manor Tremena Road, St Austell Cornwall PL25 5QG	S Willmott
Bristol Software Factory 0272-314278	Micro House St. Michael's Hill, Bristol BS2 8BS	W J Kyle-Price
Cleartone ADP 0495-244555	Prince of Wales Industrial Estate, Abercam, Gwent NP1 5RJ	E Balding
Clenlo Computing Services 01-653-6028	15 South View Court The Woodlands, Beulah Hill, London SE19	T Froud
Commodore B M (U.K.) Ltd 0753-74111	818 Leigh Road Trading Estate, Slough, Berkshire	Nick Green
Compfer Ltd 0772-57684	Preston Computer Centre 6 Victoria Buildings, Fishergate, Preston, Lancashire	D Steele
Compsoft Ltd 0483-39665	Old Manor Lane Chilworth, Guildford, Surrey	Nick Horgan
Comput-A-Crop 01-771-0867	32 Whitworth Road London SE25 6XH	Jenny Wilson
Computastore Ltd 061-832 4761	16 John Dalton Street Manchester	David Nicholson
Computech Systems 01-794-0202	168 Finchley Road London NW3	Laurence Payne
Courtman Micro Systems 0222-495257	48 Melrose Avenue Penylan, Cardiff	G Stuckey
CPS (Data Systems) Ltd 021-707-3866	Arden House 1102 Warwick Road, Acocks Green, Birmingham B276BH	N Ashbourne
CSM Ltd 021-382-4171	Refuge Assurance House Sutton New Road, Erdington, Birmingham B23 6QX	Peter Mart
Cyderpress Ltd 0491-37769	2 Church Lane Wallingford, Oxfordshire	C Murphy



COMPUTER MAINTENANCE

We have highly trained engineers on call throughout East Anglia and the West Midlands.
If you need help, we're only a phone call away.

To find out more, ring

Attleborough 454342

and as for

Martin Avons

Cinsal Computer Systems Limited
London Road, Attleborough, Norfolk, NR17 2BX.

CINSAL

• Circle No. 233

APPLE

WITH

TABS

Sales and Service for Business Systems in Hampshire & Sussex

ACCESS CONTROL SYSTEMS LTD

72 WINCHESTER ROAD PETERSFIELD, HANTS.
TEL: 0730 5274

• Circle No. 234

BOOK-KEEPING for ACCOUNTANTS & TRADERS

Purchases Day Book, Sales & VAT to run on a 32K PET.

Neat, Clear and Comprehensive Printouts. Error-proof, Fast & Easy to operate. Computes all NINE Retailer Special VAT Schemes.

Box 11 & 12 amounts and End of Year adjustments, etc.

100 Expense analysis + Goods at Zero and Std. Rates.

100 Supplier analysis.

Approved by Customs and Excise.

Only £250

For further details and sample printout

E. Stanton MBIM, 86 Bracken Drive, CHIGWELL,

Essex IG7 5RD

Tel. 01-500 4318 or 01-505 7830

• Circle No. 235

32K VIDEO GENIE

Upgrade Kit (20 mins to fit) 49.95

Upgrade Kit (factory fitted) 74.95

(inc. Securicor return carr.)

UHF TV/VDU (switchable) 74.95

inc. Free Sound MOD for V. Genie
Sound through TV Speaker

Sound Kit separately (V.G. only) 9.95

Prompt repair service for superboards and V. Genie

ARC Electronics

SANDAL, WAKEFIELD, W. YDRKS.
WAKEFIELD 253145

• Circle No. 236



ZX80 NEWSFLASH

Campbell Systems announces a flicker-free dynamic INVASION game to fit STANDARD 1K ZX80. This amazing program features fired/missed/hit/damage counts updated in real time, and missiles launched from a moving gun at a moving alien target instantly on the touch of the trigger key. And, incredibly, an accurate stopwatch clocking in 50ths of a second. All in 1K, and in perfect TV sync. Send £7 for cassette, full instructions, and we'll also explain how everything is done. Also we offer 2K INVASION for £7, or both for £8.

Also available on cassette for 3K ZX80, we offer the unique DISSASSEMBLER program, which unravels your monitor etc in Z80 assembler format.

Campbell Systems (Dept PC)
15 Rous Road, Buckhurst Hill, Essex IG9 6BL.

• Circle No. 237

GERMAN WHIST

This popular 2 play adaptation of perhaps the most widely played of all card games is now available on cassette in a compulsive computerised version using the high resolution graphics of the

APPLE II (32K)

Each card is pictorially displayed and player control is maintained solely by means of the games paddles. A single game lasts between 5 and 15 minutes but the cumulative score could take a determined player well into the night in his attempt to beat the machine. This and other games

EXIDY SORCEROR and

SINCLAIR ZX80 (1K + 16K Version)

For the Apple German Whist cassette and instructions send a cheque or P.O. for £8.50 (incl. of postage and packing) to

OCCAM SOFTWARE 13 HAWTHORN GROVE, WILMSLOW,
CHESHIRE SK9 5DE. WILMSLOW 524228

• Circle No. 238

• 23807 BYTES FREE •

That's the memory size returned when you expand your 8K UK101 or SUPERBOARD with our new:

16K DYNAMIC RAM BOARD

For just **£95.00**

- Fully built and tested
- Onboard power supply and transformer
- Socket for further expansion
- 40 Pin DIL jumper included

Send to:

Baringwood Ltd., Apt 6,
56 Cameron Rd., Seven Kings, Ilford, Essex IG3 8LF
Add VAT at current rate + £1.50 p.p.

• Circle No. 239

Algor

ZX-80 Programs

Four programs on cassette

- MAZE BATTLE:** A game of skill for two.
- MISSILE LAUNCH:** Blast the invaders!
- SKETCHER:** A useful drawing program
- MAZER:** A random-maze generator and graphics analysis program, very flexible.

ALL FOR 1K BYTES

A FULLY EXPLANATORY BOOKLET IS PROVIDED WITH THE CASSETTE INCLUDING FURTHER USEFUL SUBROUTINES.

SEND CHEQUE/P.O. TO:

ALGOR ODDER COURT, ST. JAMES RD.,
NORTHAMPTON. TEL NH 586462

• Circle No. 240

Diskdean Ltd
01-242-7394
Diskwise Ltd
05793-3780
Equinox Computer Systems
01-739-2387/9

Fylde Microcomputer Services
0253 692954

G W Computers Ltd
01-636-8210

Graffcom Systems Ltd

01-734-8862
Graham Dorian Software
01-379-7931
Great Northern C S Ltd
0532-589980

Guestel Ltd
0225-65379
Haywood Associates Ltd
01-428-9831

HB Computers Ltd
0536-83922 & 520910

Informex London Ltd
01-318-4213/7

Instar Business Systems
01-680-5330

Intelligent Artefacts
022020-689

Intereurope SD Ltd
0734-789183

Intex Datalog Ltd
0642-781193

James C Steadman
0903-814923

Jar Software Systems
Bolton 26644

Keen Computers Ltd
0602-583254

Kesho Systems
041-226-4236

L & J Computers
01-204-7525

Landsler Software
01-399-2476/7

Liveport Data Products
0736-798157

Logma Systems Design
Bolton 389854

Ludhouse Ltd
01-679-4321

Median-Tec Ltd
0734-596842

Metrotech
0895-58111

Micro Computation
01-882-5104

Micro Focus
01-379-7931

Microact Ltd
021-455-8585

Microcomputer Applications
0734-470425

Microcomputer BM
01-981-3993

Microdigital Ltd
051-227-2535

Microgems Software
0602-275559

23 Bedford Row
London WC1R 4EB

25 Fore Street
Callington, Cornwall

Kleeman House
16 Anning Street, New Inn Yard,
London EC2

48 Lomond Avenue, Blackpool,
Lancashire

89 Bedford Court Mansions
Bedford Avenue London WC1

52 Shaftesbury Avenue

London W1V 7DE

c/o Lifeboat Associates
32 Neal Street, London WC2H 9PS
116 Low Lane, Horsforth,
Leeds LS18 8PX

Refuge House
2-4 Henry Street, Bath BA1 1J

11 Station Approach
Northwood, Middlesex

22 Newland Street
Kettering, Northamptonshire

8-12 Lee High Road
London SE13 5LQ

61 High Street
Croydon, Surrey

Cambridge Road
Orwell, Hertfordshire

19-21 Denmark Street
Wokingham, Berkshire RG11 2QX

Eaglescliffe Industrial Estate
Eaglescliffe, Cleveland TS16 OPN

18 Manor Road
Upper Beeding, Steyning, Sussex

BN4 3TJ
124 Newport Street

Bolton, Lancashire
5B The Poultry

Nottingham
72 Waterloo Street

Glasgow G2
3 Crundale Avenue

Kingsbury, London NW9 9PJ
29A Tolworth Park Road

Surbiton, Surrey KT6 7RL
The Ivory Works

St Ives, Cornwall TR26 2HF
2-10 Bradshawgate

Bolton, Lancashire
2-6 Marian Road

London SW16 5HR
120 Oxford Road

Reading, Berkshire RG1 7NL
Waterloo Road

Uxbridge, Middlesex UB8 2YW
8 Station Parade

Southgate, London N14
c/o Lifeboat Associates

32 Neal Street, London WC2H 9PS
Radclyffe House

66-68 Hagley Road, Edgbaston,
Birmingham B16 8PF

11 Riverside Court
Caversham, Reading RG4 8AL

4 Morgan Street
London E3 5AB

25 Brunswick Street
Liverpool L2 0BJ

32 Buckingham Avenue
Hucknall, Nottinghamshire

R Cornforth

M Kusmirak

B Seedle

T Winter

Barbara
Castledine

J Clifford

P Clark

Allen Timpany

I Clarke

Stuart Whittaker

K Tayfoor

S Kent

D Sands

E Stoneham

T Ingle

James Steadman

J Blackburn

Bob Ellis

Angus Nial

Jack Goodman

E Landsler

G Wilkinson

R Odell

M Ward

W Stevenson

C Ogilvy

Graham Dicker

C Barnes

John Farthing

W Jupp

Graham Jones

Mrs J Wyatt



Microland 0723-70715 Micromedia Systems Newport 59276/7	17 Victoria Road Scarborough, North Yorks YO11 1SB Seymour House 14-16 Chepstow Road, Newport, Gwent	R Howard H Harrison-Allen
Micropute 0625-612818	Communique Place 9 Prestbury Place, Macclesfield, Cheshire	Don Cooper
Microsense Computers Ltd 0442-41191/48151	Finway Road, Hemel Hempstead, Hertfordshire HP2 7PS	D Page
Microtek Computer Services 0689-26803	50 Chislehurst Road Orpington, Kent BR5 0DJ	J Rothwell
Minicomputer CS Ltd 0494-448686	Pilot Trading Estate 163 West Wycombe Road, High Wycombe, Buckinghamshire	B Conlon
MMS Computer Systems 0234-40601	26 Mill Street Bedford	D Nicholls
Padmede Computer Services 025-671-2434	112/116 High Street Odiham Basingstoke, Hampshire	John Packwood
PCL Software Ltd 021-544-5071	146-150 Birchfield Lane Oldbury Warley, West Midlands	P Hemmings
Personal Computers Ltd 01-626-8121/2/3	194-200 Bishopsgate London EC4M 4NR	Steve Derrick
Petsoft Ltd 021-455-8585	Radclyffe House 66-68 Hagley Road, Edgbaston Birmingham B16 8PF	Mr Whitcombe
Profcomp Ltd 01-989-8177	107 George Lane South Woodford London E18 1AN	
Research Resources Ltd 07073-26633	40 Stonehills Welwyn Garden City, Hertfordshire	M Taylor
Rockliff Brothers Ltd 051-521-5830	2 Rumford Street Liverpool L2	W Everard
Rogis Systems Ltd 0580-80310	Keeper's Lodge Frittenden, Cranbrook, Kent	
SA Systems Newbury 45813	Allington Lodge, Round End, Newbury, Berkshire RG14 6PL	R Crowther
Selven Ltd 0376-42900	Newhaven-Ludham Hall Black Notley Braintree, Essex	Tom Wood
SMG Microcomputers Gravesend 55813	39 Windmill Street Gravesend, Kent	G Matheson
Software Architects Ltd 01-734-9402	34/35 Dean Street, London W1V 5AP	Tony Macilwaine
Southdata Ltd 01-602-4604	2/4 Avon Trading Estate London W14	N Hewitt
Stage One Computers 0202-23570	6 Criterion Arcade Old Christchurch Road, Bournemouth	J Clifford
Structured Systems Group 01-379-7931	c/o Lifeboat Associates 32 Neal Street, London WC2H 9PS	R Young
Systematics International Ltd 0268-284601	Essex House Cherrydown Basildon Essex	T Johnson
T & V Johnson Ltd 0276-62506	165 London Road Camberley, Surrey GU15 3JS	G Thompson
T W Computers Ltd 061-456-8187	293 London Road Hazel Grove, Stockport, Cheshire	A L Minter
The Alphabet Company 03046 7209	2 Whitefriars Way Sandwich Kent CT13 9AD	Keith Jones
The Software House 01-637-2108/1587	146 Oxford Street London W1	A Plackowski
Tridata Micros Ltd 021-622-6085	Smithfield House Digbeth, Birmingham B5 6BS	Dr W Unsworth
U-Microcomputers Ltd Warrington 54117	Winstanly Industrial Estate Long Lane, Warrington	N Howard
Verwood Systems 0788-87629	Verwood House High Street, West Haddon, Northamptonshire	Paul Vlasak
Vlasak Electronics Ltd 06284-74789	Thames Building Dedmere Road, Marlow, Buckinghamshire SL7 1PB	
Xitan Systems Ltd 0703-38740	23 Cumberland Place Southampton	G Lynch

MICRO ADS
are accepted from private readers only, pre-paid and in writing, 20p per word, minimum charge £2.
Please make cheques payable to Practical Computing and send to Room L311, Quadrant House, The Quadrant, Sutton, Surrey SM2 5AS.

PET PROGRAMS: Games/Business Software/Utilities for Sale (changing system) Tel. 0427 788443.

UK101/SUPERBOARD INTERFACE Upto 32 Input/Output, 8 AtoD, 2 DtoA. P.C.B. assembled/tested with I.C. sockets. Add your own I.C.s and connectors. £29 or SAE for details. Mr. D. Butler, 82 Banks Lane, Riddlesden, Keighley, West Yorks.

PLAN AND IMPROVE YOUR LIFE with a Bio-rhythm and Compatability program for the Sharp MZ-80K. State memory size when ordering, minimum 18K. Cassette £4.95. J. Tylar, 2 Chester Ave., Cranham, Upminster, Essex.

TELETYPE 43 PRINTER (with keyboard) for sale. £550 or offer. Telephone Storrington 2663.

ZX80 SOFTWARE — Four listings for 1K. ZX80. Moonlander (graphics), Pontoon, Calendar, Mathstest. Send £2. to: P. Pickering, 56 Lennox Road, Todmorden, Lancs. OL14 8QD.

CBM 2001/32K PET, Large keyboard, cassette, toolkit, cover etc. £595. Phone Rossendale 26313 Evenings.

DARTS, game of skill and dexterity for Nascom 2 with 8K, send £3.50 to P.E. Firmin, 63 Lady Lane, Chelmsford, Essex, CM2 0TQ.

FOR SALE Teletype 33 KSR excellent mechanical condition, complete with stand. £170. Sorcerer Development Pac £50. 029 83 4426 (Darley Dale)

APPLE II PLUS 48K. Disk with and without controller (DOS 3.3). 12 inch monitor. Silentype graphics printer. Appletwriter and database software. (Value £2500). Sell for £1950 o.n.o. Tel. 01-876 4613 Evenings.

UK101 PROGRAMMERS AID. Features Find, Trace, Delete Renumber, Variables List and more. Super Board compatible (2K machine code) 021-308-7012 (Richard).

16K SORCERER plus dev. Pak, blank EPROM paks, full range of manuals, software, seldom used, £595 o.n.o. 01-226 1612 (after 7pm).

FOR SALE: Tandy Quick Printer II for TRS80, no interface required. £100 o.n.o. Telephone 01-543 0360, evenings or week-end.

IBM SELECTRIC GOLFBALL computer terminal. (Reconditioned) £200 Paper feed by adjustable width tractors or pressure. Ideal for high quality output. Non-standard keyboard. Composite computer grade power supply: — +5V 5A, —5v 0.5A, +15v 2A, +24v 2.5A. Current and voltage protected. £10 — Isolation transformers, 250v/250v 200W. £5 — ASR33 Teletype £200 — High speed cassette unit (RS232) £70. — Suffolk Telephone 0787 76785.

LOWER CASE AND TEXT on Hi-Res Screen for Apple. Software, Demonstration Programs etc. All supplied on cassette. State size of machine. £5. V.J.M. Harris, 25 Thirlmere Ave, Nuneaton, Warks.

ZX80 PRINTER Hardware/Software details to interface unexpanded 1K ZX80 to Teleprinter. SAE for leaflet or £1.50 to R.T. Barton, 157 Duncombe Street, Sheffield S6 3RL.

TRS-80 L2 16K, 6 months old, with leads, c/recorder, books, magazines, software. £330. Tel. 01-435 0882, Alan (evenings).

APPLE 32K, Disc Drive and Controller B/W. Modulator. Brand new in makers boxes £1100 o.n.o. May split. Westerham (0959) 64393.

SUPERBRAIN 64K, 320K disk plus software and diskettes. As new. £1,450 (cost new with VAT £1,830). N.E.C. Spinwriter with several thimbles and ribbons. As new. £1,350 (cost new with VAT £1,550). Tel: 01-599 3943.

Peruse & choose

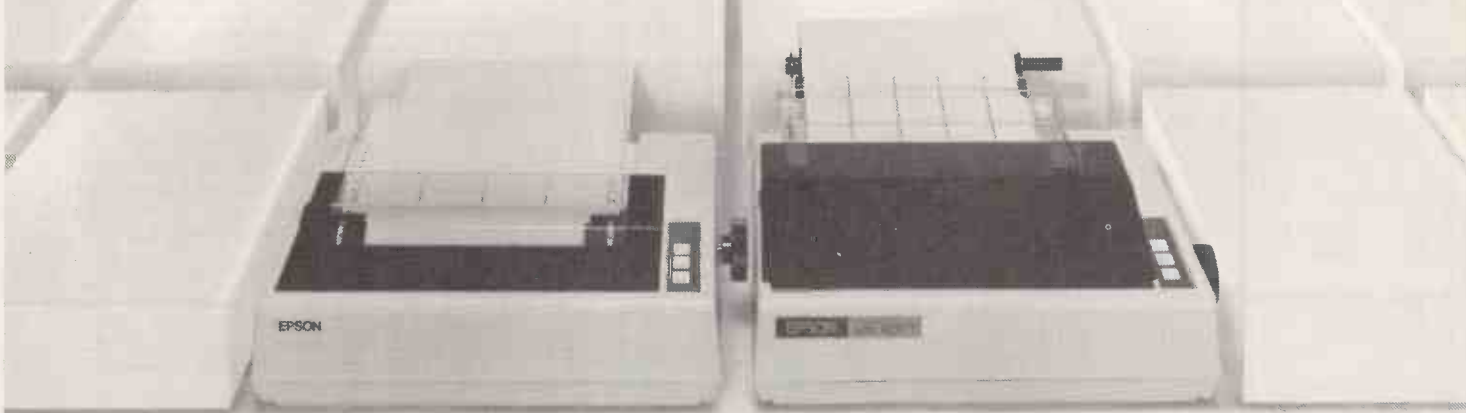

Epson printers may share a super, slim, stylish exterior but underneath are the differences which makes them really special.

The MX-80 range has a worldwide reputation for reliability, superior print quality and price. Now there's a choice to suit your precise needs and pocket.

Take these two for instance.

MX-80 F/T offers the usual Epson features - bi-directional, 80 cps, 9 x 9 matrix, standard parallel interface, cartridge ribbon, PLUS the option of friction or tractor feed.

MX-80 Plotter/Printer not only gives you an international character set (USA, UK, Germany & France) in 40, 65, 80 and 132 column widths and high general mechanism setting of 96, 115 and 159 column widths, but also boasts high resolution graphics. So now you can print illustrations, charts, graphs, block lettering etc.

We make more printer mechanisms than anyone else in the world - it makes a big difference

Find out more - contact Epson today!

EPSON

Epson (UK) Ltd

Sherwood House, 176 Northolt Road,
South Harrow, Middlesex HA2 0ED Tel: 01 422 5612/4
Telex: 8814169

• Circle No. 258

Applesoftware from Leicester Computer Centre

the correspondent
by R. Wagner

★ Now with mathematics routine ★

THE CORRESPONDENT is sure to be one of the most versatile programs in your library! It can be used as:

A Text Processor: Upper/lower case, 1-80 cols. (4-way scrolling). Text move/copy/insert/delete, tabbing, justify text, auto-centering and more!

A Database (with or without printer!) Extremely fast find routine and easy editing make it a natural for free-form data files. Create and fill out forms, access phone lists or index your magazines.

A Programming Utility: (printer or not). Examine, edit, transfer random or sequential text files. Create versatile exec. files. Even put bi-directional scrolling in your own programs!

Use the Correspondent to print-out your Visicalc formula.

Apple disk £29.95 + VAT

SUPER DISK COPY III

48K & DISK II required, APPLE II or APPLE II PLUS
SDC is a menu-driven programme that allows manipulation of all types of files under DOS 3.1, 3.2 and 3.3. SDC is the only disk utility available for the APPLE that combines these features: COPY single files (Integer, Applesoft, Binary, or Text), COPY DOS, COPY entire disk, UNDELETE deleted files, LOCK or UNLOCK files, PLOT of disk usage, and optional rearrangement of files so that they occupy contiguous sectors for improved access times. SDC supports the wildcard character "*" in file specifications. SDC makes the conversion to DOS 3.3 less painful (than MUFFIN) and also allows files to be transferred back to DOS 3.2 since both 13 and 16 sector disks can be accessed at the same time.

£24.95 + VAT

Apple-Doc

By Roger Wagner

An Aid to the Development and Documentation of Applesoft Programs

This 3 program set is a must to anyone writing or using programs in Applesoft! It not only provides valuable info. on each of your programs, but allows you to change any element throughout the listing almost as easily as you would change a single line!

With Apple-Doc you can produce a list of every variable in your program and the lines each is used on, each line called by a GOTO, GOSUB, etc., in fact, every occurrence of almost anything! You can rename variables, change constants and referenced line numbers or do local or global replacement editing on your listing.

Apple-Doc is a must for the serious Applesoft programmer.

Diskette complete with full documentation £24.95 + VAT

tridee ©Robin L. Frost

PASCAL - FORTRAN COMPATABLE An exciting new addition to your Pascal library - enables you to create 3D graphics, viewable from any angle and distance. As easy to use as Turtlegraphics. Procedures include Ortho, Perspec, Rotate, View, Move to-3, View-from. Complete with comprehensive instructions £49.95 + VAT

Apple World is here. The fast 3D graphics package that runs on your Apple II plus. Zoom, pan, tilt and scale your own designs on the Apple screen, at only £24.95 + VAT

Plus a complete range of "off the shelf" programs for finance, commercial, scientific and education. Keep yourself up to date, send for our "Fact Sheets" giving full program details.

Now available Apple FORTRAN, Dos 3.3, Apple Plot

LEICESTER

computer centre limited

67 Regent Road, Leicester LE1 6YF. Tel: 0533 556268

apple computer
Sales and Service

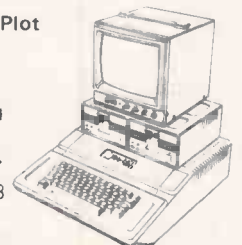

Apple III! Send for details now

• Circle No. 259

Son of Hexadecimal Kid

Samson Synapse has become a secret computer freak. He has also discovered that he can influence living things, causing plants to grow into computer peripherals. Yet when he takes a fancy to drinking his new-born sister's blood, things have clearly gone too far.

The cry of Samson's baby sister split the night. Cleo sat up in bed. "Samson, is that you? What are you doing?"

Samson ran upstairs to his room and bolted the door. He was shaking. Shame and revulsion at what he had done swept over him. Quickly he pulled on his shoes. Downstairs there was quite a commotion. The baby was still crying, and Cleo was trying to soothe it. He could hear McNull's raised voice and Cleo telling him to be quiet. Presently, there came the sound of footsteps on the stairs. There was a knock.

"Samson, come out". The door handle rattled. Samson backed towards the window.

The door would not budge. There was a pause. Then he heard his aunt's voice giving a command to Piltown 2 in Esperanto. The wooden latch began to bend and crack.

Samson did not wait for it to break. Clutching his precious potted plant he leapt out of the window and plummeted into the sand beneath. He picked himself up, shook off the dust, and tore off into the hills. He ran until he could no longer hear the confusion of shouts behind him.

Next morning he took stock. He was too proud to go home, and would not be welcome there in any case. To visit a Nullard Village, even where he was not known, would be to court death. Yet he had no idea how to survive on his own in the wild. He was a dab hand with a soldering iron and a wizard at machine code but what he needed now was food and drink. He was already feeling thirsty.

The more he thought about it, the more depressing it seemed. There was only one thing to do. He switched-on the Moonshine Micro, sat down at its keyboard and slotted a pair of his home-grown floppies into the disc drives. The drives hummed and the screen filled up with a cloud of menacing crater-pitted asteroids rushing towards him at alarming speed, cleverly projected to give an illusion of depth. It was his favourite — Astro-Pinball.

Soon he was lost among the meteorites, oblivious to the cares of the world. The counter at the top corner of the screen clicked up and up as he manoeuvred his way through the meteor swarm. He was at the helm of a great spacecraft which leaped and turned in response to fingertip pressure, weaving past the onrushing planets and zapping any alien ships foolish enough to cross his path.

Higher and higher climbed the score. He was intoxicated. Now he was destroying everything in his path — comets, moons, planets even stars with the touch of a button as he raced to the ends of the galaxy.

Suddenly a cracking twig brought him down to earth again. The sound, though quiet, stood out from the shrill electronic bleeps of his video game. He looked around. His eyes probed the chinks in the foliage. Was it just a rustle of leaves in the wind?

That moment of inattention had cost him the game. His starship had ploughed straight into a neutron star. Now the screen was a field of little dots of light, twinkling serenely. On the bottom line was an invitation for him to record his name for posterity. Desite his lapse of concentration he had beaten the previous top score by a substantial margin.

As he tapped in his initials he heard another twig snap. This time he was sure: he could feel someone's eyes on his back. He sprang up and pushed aside the overhanging branches. For an uncomfortable second he was eyeball-to-eyeball with a coarse face. The brow was furrowed in a leering frown and the eyes filled with distrust. Then it fled.

He watched the figure, clad in ragged furs, loping down away from him. It was one of the village lads from Happy Valley.

"But what the Hell was he doing up here?" Samson asked the heavens out loud. Perhaps the intruder had been out fur-trapping and had overheard the Astro-Pinball sound effects. Perhaps he had been minding sheep and one of them had strayed. The answer did not matter. What was certain was that he would head back to his folks and tell them what he had seen. A Nullard search party would be on its way before nightfall.

Meanwhile, far out in the frigid vacuum beyond the orbit of Pluto, the space freighter Green Tangerine drifted helplessly out of control. Her metal sides glinted dully in the faint light from the distant pinprick of fire that was our sun as she rolled ponderously end over end.

On the foredeck, Prestel, the ship's parrot and commanding officer, had called the two most senior of the mutant cybernoids who crewed the ship to him for an explanation. He directed his questioning at the first mate, an experienced veteran of the space lanes.

"Rom, what's the meaning of this?"

"Navigational computer sir. That cosmic ray storm put the refresh circuits out of action".

"Well, can't you fix them? What about the back-up modules?"

"Same problem, sir, we've tried. We'll have to take her to Arcturus under manual control".

Prestel gnashed his beak in frustration. He thought of the long haul to the repair

depot at Arcturus, limping along under manual guidance. It would take an eternity.

"Do you realise what we're carrying on this trip?"

Rom had no idea. He had been surprised and annoyed by the obsessive precautions during loading on Zargon 7. A security guard had machine-handled him off his own ship when he came aboard early unannounced.

"Well I'll tell you. There's no point in secrecy any more. We have a cargo of half-baked ideas to replenish the dwindling supply at Omega Solaris. It is vital we get them through before they go stale".

Rom drew in a long breath. So that was it. Now he understood the reason for all the cloak-and-dagger stuff in port. If the supply of half-baked ideas to the Think Tank in Omega Solaris dried-up, it would throw the whole galaxy into chaos.

There was silence. Prestel shifted from claw to claw on his perch.

"Well"? asked Prestel.

"Permission to make a suggestion sir"? chimed in Ram, the other cybernoid, who had held his peace so far.

Prestel leaned forward. "Yes"?

"I was checking the instruments after the radiation storm to inspect for damage when I noticed something interesting".

"Go on".

"The sensors detected evidence of intelligent life on the third planet of the local stellar system."

"Intelligent life on Terra Firma? It must be an instrument failure".

"With the greatest respect sir, there's only one configuration of signals which indicates a score of more than 10 billion on Astro-Pinball. I'd know that pattern anywhere".

"Astro-Pinball", murmured Prestel as he chewed over this nugget of information. Even their shipboard computer had an Astro-Pinball rating of less than 5 billion. As for Rom, he wasn't in the same league. A pilot of that calibre, if one truly existed, could not merely get them to their destination on time but ahead of schedule. He, Prestel, would be showered in glory.

He spoke to Rom and Ram. "You two are going on a little recruiting drive".

"Understand sir", they replied in unison, and started heading towards the exit hatches at the stern of the ship.

"Oh, and Ram —"

"Yes sir", said Ram, pausing at the door.

"You'd better be right".

"I am sir".

"Good. Because if you're not back with your Pinball Wizard within four temporal units we'll blast off without you".

**Ask for details
about Almarc
Hard Disc
Systems**

Almarc + Vector Graphic

The complete partnership
in Microcomputing

System VIP

- * Vector 3 terminal with 6-slot S100 bus.
- * Fast (4 MHz) CPU using the powerful Z80.
- * 56K of user RAM.
- * Serial RS232 port (110-9600 baud selectable), 3 8-bit parallel ports.

- * 80 x 24 display using 8 x 10 matrix.
 - * Full QWERTY keyboard plus separate numeric keypad and capacitance keys.
 - * UNISTOR disc drive giving 315K bytes of storage.
- PLUS CP/M 2, Microsoft BASIC 80, SCOPE (text editor) and RAID (simulator debugger).



System B

- * Vector mindless terminal.
- * Z80 CPU with fast 4 MHz clock.
- * 64K bank-selectable RAM (56K user RAM).
- * 4 serial ports (all switch-selectable 110-9600 baud), 5 parallel ports.
- * Flashwriter II video board (80 x 24).

- * Interrupt handling on I/O board.
- * Twin disc drives - 630K capacity.
- * CP/M 2.2 operating system.

PLUS
Microsoft BASIC 80, SCOPE (screen-oriented program editor), RAID (full screen dynamic simulating debugger), ZSM Z80 Assembler.



System 2800

- * Vector 3 console chassis with 12 inch CRT and capacitance keyboard.
- * Z80 based single board computer with serial port, 3 8-bit parallel ports, 3 PROM slots and 1K RAM.
- * 64K dynamic memory board and disc controller.

- * Flashwriter II video board (80 x 24).
- * 6 slot S100 motherboard
- * Switch-selectable asynchronous baud rates (110-9600 bits/sec).
- * IBM-compatible DUALSTOR twin 8 inch double density disc drives, giving 2M bytes capacity.

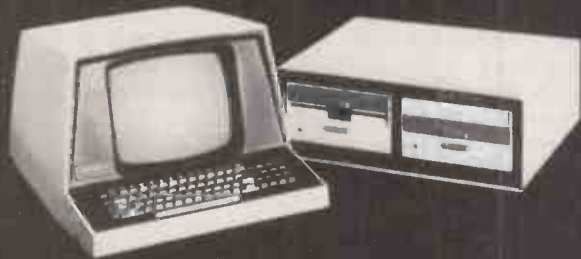

At ALMARC Data Systems, you can be sure of our experience of hundreds of Vector Graphic systems installed throughout the U.K. - all with 12-month warranty and the back-up of full service facilities carried out by experienced staff.

ALMARC are the specialists in Vector Graphic equipment with applications in word processing, business

systems, laboratories, research, schools, colleges, universities and industry. Plus an ever-growing list of compatible software - Pascal, Fortran, Cobol, APL, Algol, Basic Compiler and others.

We will be pleased to demonstrate how ALMARC + VECTOR GRAPHIC Systems equals The Complete Partnership in microcomputing.

906 Woodborough Road, Nottingham NG5 5QS. Telephone: (0602) 625035.

• Circle No. 260

PRACTICAL COMPUTING May 1981

Almarc

DATA SYSTEMS

RIL

2 new low cost printers.

£420

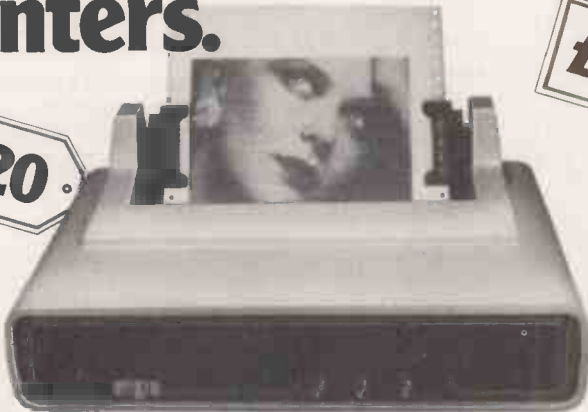

MPI 88G

- Full dot addressable graphics
- 1K buffer standard, 2K optional
- Tractor, Paper roll or single sheet feed
- Bidirectional 100 cps. impact printing
- ASCII, 20m/A loop, RS232, IEEE
- 80, 96 and 132 ch per line
- 96 ch ASCII. Upper, lower case +NLQ 11x7.

40 and 80 column impact matrix printers with sensible price tags – just right for the personal and professional user.

£289



EATON LRC 7000+

- Rugged low cost design matrix impact printer
- 40 columns, 1.25 lines per sec.
- Interface cables for PET, TRS80, ATARI, APPLE etc.
- 100 million character head life.

Russet Instruments Ltd

Unit 1 Nimrod Way, Nimrod Industrial Estate, Reading, Berkshire RG2 0EB, U.K.
Telephone 0734 868147 Telex 849721

• Circle No. 261

NICE AND EASY DOES IT Panasonic Hardware + CPS Software

The quality and reliability of Panasonic microcomputers is complimented by two new CPS programs specially developed to work with Panasonic hardware—OASIS and COMTEXT



Dealers! CPS are Panasonic Distributors
Would you like to sell Panasonic micros, OASIS and COMTEXT

CPS (DATA SYSTEMS) LTD



Third Floor, Arden House,
1102 Warwick Road, Acocks Green,
Birmingham B27 6BH
Tel: 021-707 3866
A member of the CPS Group

OASIS PLUS COMtext

Wordprocessing and Communications System

Business system
Fully integrated
Easy to use

An interlinked suite of programs forming an advanced wordprocessing and communications system which facilitates the creation, manipulation and distribution of text simultaneously around an organisation with offices in different locations

If you want to know more about OASIS, COMTEXT and Panasonic microcomputers, talk to CPS on 021-707 3866 or complete the coupon

Linked Functions

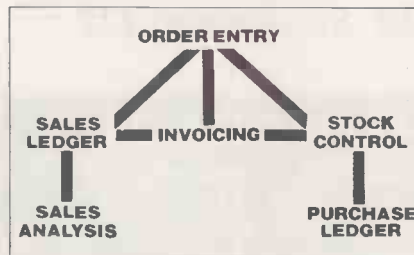

CPS (Data Systems) Limited,
FREEPOST, Birmingham B27 6BR
Please send me details of Panasonic micros,
OASIS and COMTEXT

Name _____
Position _____
Company Name and Address _____

Telephone _____

CPS where performance and good value matter

• Circle No. 262

SuperFile *Ends file-handling*

SUPERFILE gives the programmer a:
CONTENT ADDRESSABLE DISC

*COMPLETELY FLEXIBLE — add new information and new KINDS of information whenever you like. Start with a list of names, addresses and telephone numbers. Then add invoices, employee details, a stock list. You don't have to guess today what sort of information you'll want to store tomorrow.

*WORD PROCESSOR with on-line spelling correction coming soon: store all your documents in the database — indexed by dates, names, subjects.

*THINKS LIKE PEOPLE — is it: Thomson, Thompson, Tomson, Tomassen, Tomassin, Thomasson? No problem: SUPERFILE has a fuzzy matching mode which will bring back anyone whose name *sounds* like Thomson.

*VERY FAST — *all* data items are indexed. Access any Record in an 8MB file (CP/M 2.2's limit) in 1/5th of a second.

*MOVE UP direct to hard discs and networking under CP/NET. SUPERFILE is designed with them in mind. No changes necessary to programs or files.

*COMPACT — 10K of relocating code that extends CP/M at the top of memory.

*RUNS WITH MBASIC — you don't have to learn a new, complicated database language. Load and run MBASIC (and FORTRAN or machine code) just as you would under CP/M. We give you a skeleton program in MBASIC — write your own code in the middle.

*INTERACTIVE ENQUIRY facility supplied as standard. Have a quick look at the database any time you want without writing a program.

*GOING TO MISS FILEHANDLING? Going to miss paying to have filehandlers written? Tough.

SUPERFILE is written in Z80 machine code running under CP/M. It is supplied on 8" SSSD. Dealer enquiries invited.

Prices: **£650** (UK and Europe); **£50** for demo disk with Enquiry Facility and manual; **£10** for manual.

CORRECTOR spelling correction package: **£150**,
Manual **£5**.

SOUTHDATA LTD
221 PORTOBELLO RD, LONDON W11.

• Circle No. 263

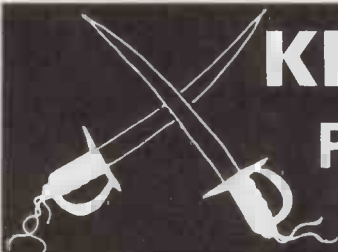

KRAM ELECTRONICS RUTHLESSLY SLASHES THE COST OF PRINTING!!



- Centronics 730 100cps printer **£345**
- Centronics 737 Proportionally spaced word processing quality **£395**
- Case for UK101/ Superboard **£24**
- Pet-Centronics Decoded Interface **£50**
- 4K Ram for UK101 **£30**
- Additional Educational Discounts
- Pet-RS232 Interface **£80**
- Channel Synthesiser for Pet (IEEE Compatible) **£50**
- Numeric Pad for UK101/Superboard **£12**

KRAM ELECTRONICS

30 HAZLEHEAD ROAD
ANSTEY LEICESTER

053-721-3575

ALL PRICES SUBJECT TO 15% VAT



• Circle No. 264

SIRTON COMPUTERS



76 Godstone Road, Kenley (Nr Croydon) Surrey CR2 5AA
Tel: 01-668 0761/2

NOW WITH MP/M

MIDAS S.100 SYSTEMS

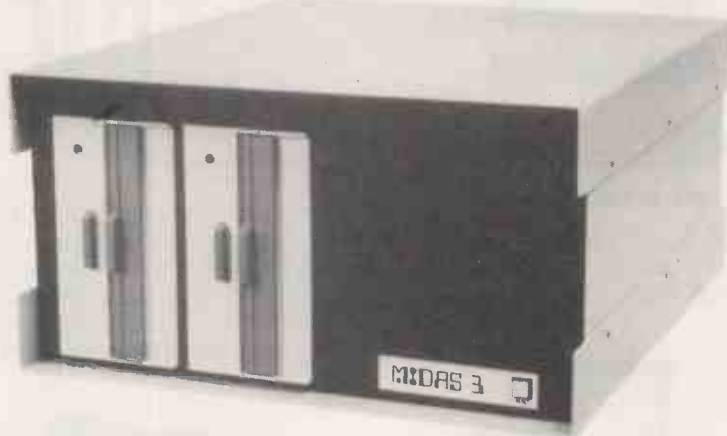

MIDAS 1: From £750
MIDAS 2: From £1580
MIDAS 3: From £2150
MIDAS 4: From £5900
ITHACA-DPS 1: From £1075

- Our versatile Z80 Microcomputers are available as standard units or custom configured to your exact specification from a comprehensive range of stocked S100 boards.
- Disc storage capacity of the MIDAS 3 can be 2M Bytes, expandable to over 20M Bytes with a Winchester Hard Disc Unit in our MIDAS 4 range.
- MIDAS runs CP/M and MP/M is also available. Other Software includes M-BASIC, C-BASIC, FORTRAN, COBOL, CIS-COBOL, PASCAL and Word Processing.
- **A MIDAS 3, with 64K RAM and 2M Bytes storage on two 8" drives with two Serial I/O Ports and CP/M 2 only £2835.**
- Multi-User System (four users) — MIDAS.3 with four 48K blocks of RAM, 1 MByte disc storage on two 8" drives and four Serial I/O Ports, and CP/M 2 + MP/M — **£3850.**
- Printers, VDUs and other peripherals stocked to give complete package systems at keen prices.
- Business Packages include Accounts, Stock Control, Purchase Ledger etc etc.

Boards stocked from Ithaca, Godbout, SSM, S D Systems, Vector, Micromation, Mullen, Mountain Hardware, Hi-Tech, Video Vector, Pickles & Trout, Central Data, Cromemco, Thinker Toys — Send for full Price List (many available in kit form).

Processor		RAM	
Z80 Starter Kit	£188	Dynamic RAM 16K-64K	from £205
SBC100	£208	Static RAM 8K-64K	from £95
8085/88 CPU	£237	Memory Manager	£52
Z80 CPU 4 MHz	from £130	I/O	
		2S/4P prov 4K RAM/4K ROM	£169
EPROM		2S/2P or 2S/4P or 3P/1S or 4S/2P	from £135
2708 EPROM (16K)	£60	Analogue 8 or 12 bit	from £287
2708/2716 Programmer	from £134	Optically isolated I/O	£114
		IEEE 488 Interface	£350
Video		Miscellaneous	
16 lines, 32/64 ch	from £104	Real Time Clock	£180
24 lines, 84 ch	from £265	High Dens Graph/8K RAM	£333
		Hi-Tech Colour	£295
Disc Controllers		Motherboards — various from	£34
Versafloppy S/D	£198	Extender Board/logic probe	£39
Doubler D/D	£280	Maths Board AMD 9511	£330

Mainframes

We are the sole UK Distributor for Integrand Mainframes and Disc Enclosures, available in nine models including Desk Top and Rack Mounting, with or without provision for Disc Drives. All units totally enclosed, painted on all external surfaces and complete with power supply etc.

Software

CP/M 1 & 2, MP/M, PL/1, C-BASIC 2, M-BASIC V5, XYBASIC, FORTRAN 80, COBOL 80, CIS-COBOL, PASCAL/Z, PASCAL (UCSD), PASCAL M/T, Forth, MAC, ZSID, Disassembler, Wordstar, Datastar, Magic Wand, Wordmaster, Supersort etc etc.

WRITE OR PHONE FOR CATALOGUE
PRICES EXCLUSIVE OF VAT

• Circle No. 265

Your search for the right price stops here.



Pet

Well known for making short work of accounting, word processing, mailing lists. A great buy from NSC.



Apple

You know what the Apple system will do but you don't know the deal we're offering. Come and see for yourself.



Rair

The exciting new 3/30 system offering 5 mb of fixed disc storage on brand new 5 1/4" Winchester drives. 64K Machine £4,313 incl. VAT. Full range of black box systems available. Rental terms available.

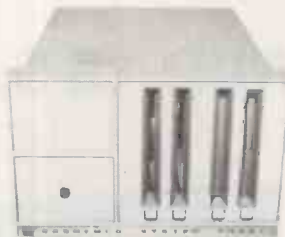

Cromemco

We can now supply the Cromix operating system for single and multi user working. The first big system operating system to be offered on a small system—the only system which offers up to 63K memory space per user.



Acorn Atom

Now available ex-stock. Special offer to ZX80 owners: We will take your ZX80 in part exchange for an Atom.

Used Bargain: Second hand ZX80's from £50.



North Star Horizon

A complete word processing system extendible from 32K-56K RAM, with up to four mini disc drives, 4MHz Z80A processor, serial and parallel I/O ports and extended BASIC. Full range of accounting packages available. You can lease this very popular system for as little as £25 per week.

Bargain Offers

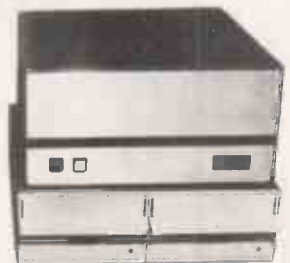

South West Technical Products

56K 6809 based system, with twin 8" disc drives and Centronics 779 printer. From £3,163 incl. VAT, while stocks last. Keenest prices around on individual boards and peripherals.

48K Apple for £695

Buy a 16K Apple from NSC Computer Shops now and get 32K FREE.

After Sales Service

When you buy from NSC Computer Shops you have the opportunity to take advantage of a special service contract on favourable terms.

Order by post with confidence

Instead of calling personally at NSC Computer Shops you can send cash with order. Orders are despatched by carrier, please telephone for details of delivery charges.

BOOKS: Send s.a.e. for our full price list, or call in at our shop to see our wide range of publications.

Most of our prices are heavily discounted and therefore payment must accompany the order. Credit card payments will be accepted. Please quote credit card number and type of card.

WE WILL NOT BE KNOWINGLY UNDERSOLD.

NSC COMPUTER SHOPS

Computing to suit your size.

NSC Computer Shops, 29 Hanging Ditch, Manchester M4 3ES. Ring 061-832 2269 for further information.

• Circle No. 266

LONDON COMPUTER CENTRE

New! – Improved! NEW LOW PRICE £1095
Additional Facilities – + Built in proportional spacing

60 CHARACTERS PER SECOND
 THE FASTEST DAISY WHEEL
 PRINTER.
 FAST, heavy duty commercial DAISY
 WHEEL printer, with high quality
 printout, coupled with low noise
 necessary for office environment. 124
 char: upper/lower case. * 10/12 chars:
 per inch giving 126 or 163 columns.
 * 15 inch wide friction platen.
 BOLDING, underline, and host of other
 features. * Centronics type parallel
 interface as standard options: serial
 interface £60 * PET interface £65 *
 APPLE Interface £75.

Made by Ricoh in Japan
 DEALER ENQUIRIES INVITED

+ Look-ahead logic + On-off switch
NEW LOW PRICE £1095

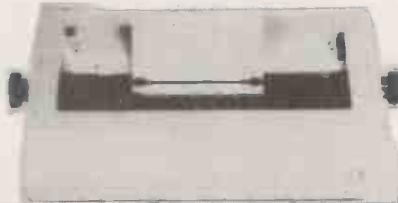

← TRS 80 Model I & II

← SUPERBRAIN

← APPLE

← PET

← HORIZON Etc

TRACTOR FEED O/E £175
 SHEET FEEDER OPTIONAL EXTRA £550

NEW MAXI ANADEX WITH GRAPHICS £895



Takes up to 13.6 inch wide
 paper * Upper/lower case with
 descenders * £ sign * 132 or
 175 chrs/line with double width
 printing * Fast 150 CPS bi-
 directional logic seeking printing
 * Heavy duty print head giving
 650 million chrs print life *
 serial, Parallel and Current Loop
 Interfaces built in * Host of other
 features found on printers costing
 twice as much.

Also Available
 DP8000 £425 (Not Illus)
 DP 9501 £995 (Same as 9500 Illus)

NEW! Revolutionary! Epson MX80F/T £399 the PRINTER with FRICTION & ADJUSTABLE Removeable TRACTOR FEED

Dual print modes letter quality standard dot matrix



ULTRA QUIET.
 LOWER CASE DECENDERS
 BI DIRECTIONAL, LOGIC SEEKING
 PRINT HEAD
 40, 80, 66, 132 Columns per line
 UNIQUE BOLD FACE & DOUBLE STRIKE
 (BUILT IN FEATURE)
 64 Graphic Characters (TRS80 & Prestel)
 9 x 9 PRINT MATRIX, £ sign
 Forms Handling, Top of Form
 Horizontal and Vertical Tabs.

Centronics parallel interface standard.
 Optional extra Serial, PET & APPLE interfaces.
 Easily replaceable head.
 After 50,000,000 to *100,000,000 characters the head can
 be replaced without technical knowledge or assistance for £15.00
 *Approx. 38,000 copies of A4 letters.

OKI MICROLINE 80/132. THE QUIET PRINTER YOU CAN LIVE WITH

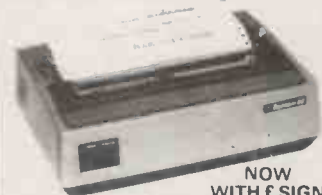

NOW
 WITH £ SIGN

The quietest Dot Matrix available. 40, 80
 or 132 cols per line * excellent print
 quality * 3 way paper handling: letterheads,
 fanfold, or paper rolls * graphics * Ideal
 for software written for large 132 col
 printers * continuous rating printing day in
 and day out * centronics parallel standard.
 Options: R5-232, PET, Apple.
 Dealer enquiries invited.

NEW LOW PRICE £350

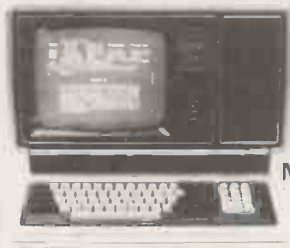

TRS-80
 MODEL II

State the art second generation computer. Over
 10,000 already sold in USA: 8 slot bus ensures
 expansion of hard discs & other peripherals., 76
 Key professional keyboard, self test on power up,
 TRSDOS & Level III basic standard. CP/M available
 as option, making a wide range of accounting,
 educational, scientific & word processing packages
 instantly usable.

Nationwide service through 180 Tandy stores &
 computer centres.

NOW WITH CP/M 2.24 £1999

SUPERBRAIN



350K £1595
 700K £1995
 1600K £2595

64K RAM Standard
 on all models

NOW with MULTICOLOURED DEDICATED
 KEYS for MAGIC WAND, the ULTIMATE
 WORD PROCESSOR

TRS-80 MODEL I FROM £312



NEW LOW PRICES
 48K system with Dual Disk Drives . . . £1095
 With Epson Printer £1350

New green screen VDU with rock steady display.
 Redesigned 32K expansion interface with trouble free
 operation and two 40 track disc drives.
 16K Keyboard with Modulator. £312
 16K System: Keyboard, Green Screen &
 Cassette £414
 Dual 40 Track Disc Drives & Cables £420
 32K Expansion Interface. £299

VISICALC for TRS-80 MODEL I £52

CPM SOFTWARE

Word Star	£250
Word Star Mail-Merge	£315
Magic Wand	£185
Magic Wand with dedicated keys	£235
Data Star	£195
T/Maker	£155
Report Writer	£90
Accounts Packages	from £295
Payroll	from £295
Various other packages available – ask for details	

SOFTWARE FOR TRS-80

Electric Pencil (disc)	£60
Electric Pencil (cassette)	£35
Scriptit (disc)	£75
Scriptit (cassette)	£60
Mail-Merge for Pencil/Scriptit	£45

VAT A14 Programme	£45.00
Visicalc	£52

MISCELLANEOUS

Floppy discs (Box of 10) including library case.	
XLtron Silver 5" S/Sided D/Density	
for TRS-80, PET, Apple & Superbrain	£25.00
XLtron Gold 5" D/Sided D/Density	
for Superbrain	£30.00
XLtron Silver 8" S/Sided S/Density	£20.00
Memorex 8" S/Sided D/Density for TRS-80	
Model II	£35.00
Qume Daisywheels	£6.00
RP-1600 Daisywheels	£15.00
2000 Sheets 11" x 9.5" Fanfold Paper	£15.00
2000 Sheets 11" x 14" Fanfold Paper	£20.00
Ribbons, Paper Rolls etc.	POA

LOW COST WORD PROCESSOR I

Based on TRS-80 level 2 16K cassette recorder,
 electric pencil software, upper/lower case mod,
 printer interface and OKI Dot Matrix printer.
 Complete ready to go £895 free mailing list program.
WORD PROCESSOR II
 Same as above but with 48K, 2 disc drives
 and rich daisy wheel printer £2275
WORD PROCESSOR III
 Based on Superbrain Computer shown above.
 With Ricoh printer & "Magic Wand" the ultimate
 in word processing. Letters automatically formatted
 with addresses fetched from separate file.
 Complete system £2950. Invoicing, stockcontrol,
 sales ledger, purchase ledger, payroll available for
 above computers from £250 per package.

DEALER ENQUIRIES INVITED ON ALL PRODUCTS

43 GRAFTON WAY, (OPPOSITE MAPLES), LONDON W1
 TEL: 01-388 6991/ 2 OPENING HRS: 11-7 MON-FRI, 12-4 SATS. 24 HOUR ANSAPHONE 01-388 5721

• Circle No. 267

Microtrend software and the Adler Alphatronic NOW YOU'RE TALKING BUSINESS

Microtrend Ltd., has software now for the microcomputer with a future. This wide range of well-specified, user-friendly and professionally-packaged products includes five accounting systems, two word processors (plus an inter-micro communications system for electronic mail and other data transfer operations).

Adler Business Systems provide Microtrend's Trendisk/1 Data Management System free of charge with each Alphatronic.

Combine our excellent software with the superb Alphatronic and you are really talking business. Microtrend products are available off the shelf from your local dealer or distributor.

Call 0423-711878 or write to
Microtrend Ltd.,
P.O. Box 51,
Pateley Bridge,
Harrogate, HG3 5DP.,
for more details.



Professional Software for Microcomputers

• Circle No. 268

TRIPS TO THE

HANOVER FAIR

APRIL 1-8
1981

IPC Electrical-Electronic Press Ltd., the world's largest publishers of computer, electrical and electronic journals, in association with COMMERCIAL TRADE TRAVEL LTD., have arranged special visits to the Hanover Fair. All accommodation has been reserved at the Hotel Konigshof, DBAD OEYNHAUSEN. However space is limited on all departures, so in order to avoid disappointment, early reservations should be made.

FROM LONDON (Heathrow)

TOUR A — 4 days (3 nights)

Tuesday, March 31	Dep. Heathrow	BA776	17.15
	Arr. Hanover		19.40
Friday, April 3	Dep. Hanover	BA775	18.20
	Arr. Heathrow		18.50

TOUR B — 4 days (3 nights)

Friday, April 3	Dep. Heathrow	BA774	15.15
	Arr. Hanover		17.40
Monday, April 6	Dep. Hanover	BA775	18.20
	Arr. Heathrow		18.50

INCLUSIVE PRICES (Single room with facilities)

Tours A & B £260.00

More information: Commercial Trade Travel Ltd
Carlisle House, 8 Southampton Row, London WC1

PRACTICAL COMPUTING BACK NUMBERS & BINDERS



BINDERS

UK — £4.60 including packing, postage and VAT
Overseas — £5.75 including packing and postage
Please make all cheques payable to *Practical Computing* and sent to the General Sales Dept.

BACK NUMBERS

Fill in the coupon in every issue and return it with your remittance to *Practical Computing*, General Sales Dept. Room 205, Quadrant House, The Quadrant, Sutton, Surrey SM2 5AS.

IBM SELECTRIC GOLFGALL PRINTERS AND INPUT, OUTPUT 735 TYPEWRITERS

PRINTERS FROM	£195.00
735 TYPEWRITERS FROM	£245.00
WIRING AND COMMISSION TO SUIT	
ACULAB INTERFACE	£ 48.00
ACULAB INTERFACES EX STOCK	£155.00

ALSO AVAILABLE IBM 71, 72, 82 typewriters
Full workshop facilities for rebuilds and servicing.
Keyboard ASCID-ASCII, 10-12 pitch, language conversions undertaken.
11", 13", 15" platen lengths, split platens pin feed platens. Operational keylever repeats fitted on request.
Full IBM range of 10-12* pitch heads including language, symbol and metric.
Language keybuttons blue or grey.

WE BUY SELL OR EXCHANGE ALL IBM SELECTRIC TYPEWRITER MODELS

FOR FURTHER DETAILS PHONE **STUART KIRBY OR LOUIS BAKER**

KEYTRONICS SAUL LODGE SAUL GLOUCESTER GL2 7JE
TEL. 0452 740 612

PRICES EXCL VAT @ 15%
& CARRIAGE & PACKING
CALLERS BY APPT ONLY PLEASE

• Circle No. 269

BITS & PCS

COMPUTER PRODUCTS LTD

4 Westgate, Wetherby, West Yorks, LS22 4LL
Telephone (0937) 63744/63774

THE NORTH'S LEADING NASCOM SPECIALIST

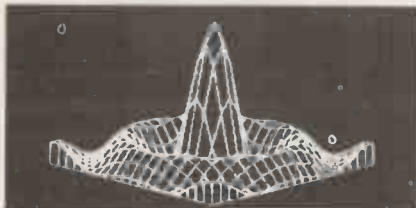

PROGRAMMABLE CHARACTER GENERATOR FOR NASCOM 2
8192 Programmable dots Memory mapped with demo software and free game £60.00

NEW PRODUCTS FOR NASCOM:

DISCS:

Single drive £380.00
Double drive with CPM & EBASIC £640.00
Ask for details
Professional designed for your NASCOM

KENILWORTH CASE

A high quality case made from stielvetite coated steel and solid mahogany £49.50
Mounting Kit for two cards £350
Mounting Kit for five cards £19.00

SARGON CHESS PACK

This pack includes the book and a tape with Sargon prepared to run under NAS-SYS. Also included in a special graphics rom and a PCB giving your NASCOM the ability to switch between two graphics ROMs, your original and the chess ROM. All the above for only £35.00

EPROM PROGRAMMER

This unit allows the NASCOM user to programme both 2708 2716 EPROMS complete with operating software £25.95

EPROM ERASER

Erasers 28 roms in 20 minutes £34.00

INTERFACE EPROM BOARD

Provides sockets for both 2708 and 2716 EPROMs (up to 16 EPROMs) and also provides a fully decoded socket for the NASCOM 8K BASIC ROM. This board is produced to full NASBUS specification and can be used in 'page mode' together with the new NASCOM RAM B. Wait states may be generated on board to allow a NASCOM 1 to run at 4MHz in BASIC. The complete Kit at only £55.00

CASTLE INTERFACE

Gives the following features: — Auto tape drive * Auto cassette muting * Auto serial printer muting * 2400/1200/300 BAUD cassette. This interface built and tested complete with documentation at only £17.50

ASTEC 10" B/W MONITOR

A Professional Cased 10 inch Monitor giving superb resolution, only £80

ANALOGUE TO DIGITAL CONVERTER

This unit gives 4 Channels with an Input Range of 0 to 120mV up to 0 to 24V. Conversion time (average) 0.5mSec. Supplied built and tested at only £49.50

DUAL MONITOR

This Kit allows switching between two monitors on a NASCOM 1 e.g. T4 and NAS-SYS £6.50

PORT PROBE

A very useful device for testing and evaluating ports and peripheral software with improved documentation £17.50

HEX AND CONTROL KEY PADS

Our popular range of add on key boards for the NASCOM micros
HEX for NASCOM 2 £34.00
HEX & CONTROL KEYS for NASCOM 1 £40.50

PROGRAMMERS AID

In 2 2708 EPROM gives the NASCOM ROM BASIC many extra commands: AUTO, RENU, DELE, DUMP, FIND HEX, APND, HELP ... etc. £28.00

BITS & PC.s GAMES TAPE 1

Good value — ten excellent games £8.00

BOOKS

Full range including INMC mags
Epsom MX80 £360.00
Eikosho GP80 £250.00
Software interface details supplied for Nascom users

PRINTERS

SHARP
MZ-80K 48K RAM £450.00
PC12 Pocket Computer £82.00
PC12 11 Cassette Interface £13.00
PC12 11 Printer £85.00

TEXAS T199/4 SPECIAL OFFER 3 only

Complete with accessories normal price £950.00
including B & W Monitor OUR PRICE £480.00

BUILT SYSTEMS REPAIRS MAIL ORDER and ADVICE are our SPECIALITY

FULL RANGE OF NASCOM PRODUCTS
SAE FOR DETAILS. PRICES EXCLUDE VAT AND POSTAGE/PACKAGE

Access & Barclaycard Welcome



Why Software Houses should talk to us – fast!

The best in microcomputers from Extel: We are a Division of the Group bearing one of Britain's foremost names in communications – and a City institution in its own right for over a century.

We are able to offer from our associated company, Digital Microsystems Inc of California, the range of 'DSC' microcomputers based on the Z80A processor. These are available in single-user and multi-user configurations, operating under CP/M or Micro Cobol. The 'Hi Net'® multi-tasking and network micros are also being delivered now.

We have a range of printers and VDU's to enable you to offer a turnkey system without hardware worries.

We want to talk to Software Houses like yours on matters of mutual interest and the benefits we can pass on are impressive. Run your eyes down the list!

- * We operate a nationwide maintenance service with over 100 field engineers.
- * We will provide you with inquiries from our National Advertising Campaigns.
- * We will assist you in running Seminars.
- * We have literature and promotional material available.
- * We have software and hardware support teams to give you assistance.
- * Our demonstration facilities are available in London and Manchester.
- * We will help sell your software through our Salesforce.
- * We believe in a close working relationship to achieve our mutual aims.

Don't wait to discover what co-operation with Extel could mean to your organisation. Do something about it now! Telephone, telex or write to John Brooks (Principals only please).

The Exchange Telegraph Company Limited,
73-75 Scrutton Street,
London EC2A 4TA.
Extel® Telephone: 01-739 2041.
Telex: 27595.

 **commodore**

**INDUSTRIAL
MICRO
SYSTEMS**



Qume

NorthStar 

 **apple**][

 **Anadex Ltd.**



MICRO FACILITIES

APPROVED

for
Commodore
Apple II
North Star Horizon
Industrial Micro Systems 5000
& 8000

APPROVED

by
Local Government
Central Government
National Laboratories
Maritime Research
Universities
Schools

APPROVED

by
Accountants
Importers/Exporters
Retailers
Manufacturers
Printers
Surveyors

WE WILL GET YOUR APPROVAL

Why? Because Micro-Facilities know that whether you are a large establishment or a small business you are going to need **help** and good **service**. We believe, and our hundreds of satisfied customers seem to agree, that the service we give is second to none.

Our service starts right from your initial contact. We will meet with you to discuss your requirements and your **business**, without blinding you with computer jargon. We will arrange for you to have a demonstration of one or more computers from our range together with programs to suit your particular needs. If a ready-made program is not suitable then we can analyse, design and program your particular procedures (we have nearly twenty years experience of doing this).

As a further service we are able to arrange both **leasing** and **financing** of your computer equipment.

Our service does not stop when you have purchased your system; to ensure the smooth transfer of your work we **train** you and your staff to use the computer and its programs in your own environment. As additional security we offer full **maintenance contracts**. Above all we will be available to give you genuine **after sales service**. Not for just one week or one month but everytime it is wanted.

Please contact us to discuss your problems and requirements, we offer you a lot more, but only charge the same. Our ability will give you peace of mind and confidence that the job will be done properly.

Central Computer & Telecommunications Agency Approved
Tenders from Local Authorities, Education and Government
Departments welcomed.

Micro-Facilities Ltd. 129 High Street,
Hampton Hill, Middlesex TW12 1NJ

01-941 1197 and 01-979 4546

**MICRO 
FACILITIES**

• Circle No. 272

Master Your Micro FAST with...

Little Genius floppy diskette based courses will teach you, how to use your system and how to realise the full potential of the "Mighty Micro". These fully interactive computer lessons will guide you quickly to a high level of understanding and confidence in your ability to make the most of your microcomputer system.

Courses now available:

- | | |
|----------------------------|--------------------------|
| - Applesoft BASIC | - Palsoft BASIC |
| - Advanced Applesoft BASIC | - Advanced Palsoft BASIC |
| - Using your Apple | - Using your 2020 |
| - PET BASIC | - 380Z BASIC |
| - Advanced PET BASIC | - Advanced 380Z BASIC |
| | - Using your 380Z |



Little Genius

Each course, comprising a floppy diskette, and starting instructions, costs only £40.00 plus VAT.

SPECIAL "3 in one" OFFER for 3 courses covering the same system only £99.00 plus VAT.

Little Genius courses are available from most computer retail outlets, or direct mail order from:

LITTLE GENIUS

Suite 504, Albany House, 324 Regent Street, London W1R 5AA.
Telephone: 01-580 6361

• Circle No. 273

Atom Explosion in Cambridge!

See the sensational Acorn Atom on demonstration at Cambridge Computer Store. Also the Acorn kit systems and the UK101: all available off-the-shelf or on short delivery.

We have low-power 2114 RAM at competitive prices and the stock in our Electronics Department includes a huge range of IC's and components.

Cambridge Computer Store

1 Emmanuel Street
Cambridge CB1 1NE
Phone (0223) 65334/5

• Circle No. 274

SUPERBRAIN



350K Superbrains* at competitive prices. Ex stock.

700K & 1.54 Megabyte models available.

Hard disk — 10 Megabyte Winchester drives.

Super video board — adds true lower descenders, reverse video & flashing underline cursor to your Superbrain.

SOFTWARE

SUPERBIOS has arrived! £100. It enhances your Superbrain, supports 5 1/4 & 8" drives, has repeat key function, type ahead facility, speedier disk accessing and real time clock.

LANGUAGES — BASIC, COBOL, FORTRAN, PASCAL, APL etc.

- Word Processing
- Database
- Integrated Accounts
- Incomplete Records
- Solicitors' Accounts
- Etc.

Tailor made software to suit your particular needs.

PRINTERS

IBM GOLFBALL PRINTERS
From £395 + VAT



Reconditioned printers with keyboard and RS232 serial or parallel interface.

Tec DAISYWHEEL printer with DIABLO mechanism which produces quality print at a dot matrix price. From £1085.

Oki range of reliable, quiet dot matrix printers. 80, 82 & 83 Ex stock from **£349**

E.I.S.
Electronic Information Systems
Frampton Cotterell
BRISTOL
Tel: Winterbourne
(0454) 774564 or 775150

DAY 1 MAINTENANCE AVAILABLE — FULL TRAINING & SUPPORT

WE SERVICE ALL OF THE ABOVE EQUIPMENT
(Maintenance contracts available) VAT at 15% should be added to all prices.
*Trade mark of Intertec Data Systems

• Circle No. 275

Daisy, Daisy...

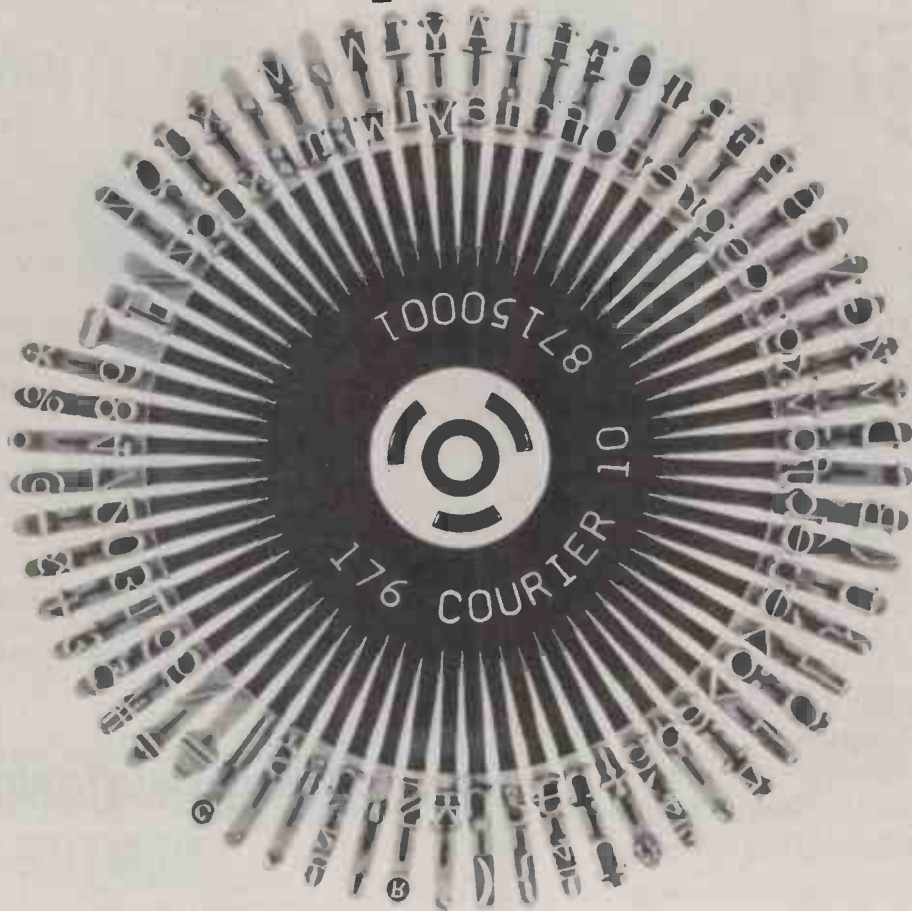

The ultimate answer to your printer needs

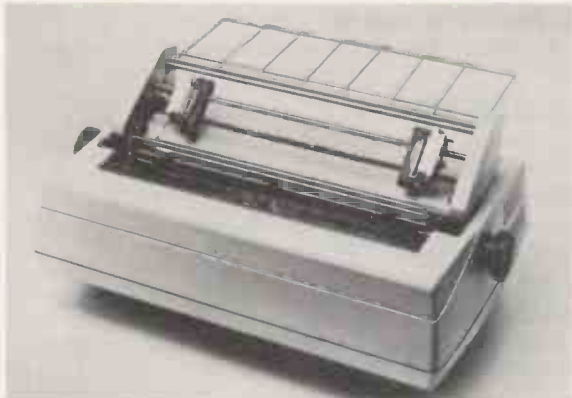

The Nexos Ricoh RP 1600 Daisywheel Printer with the unique Double Daisy. She's tough – and fast. Two characters per petal, plus rugged dual-plastic construction add up to double your printer – 60cps with the excellent print quality you need – for less than you need to pay.

Now available ex-stock from our new dealer network.

Micropute Microcomputer Systems
Macclesfield (0625) 612759/612818

Camden Electronics Limited
Birmingham (021) 773 8240/772 5718
Butel Comco Southampton (0703) 39890

Macron Computer Services Limited
Bourne End (06285) 27510

HB Computers Kettering (0536) 520910
Sumlock Bondain London (01) 250 0505

Softech Ltd Dublin 2 (0001) 784739
Software Development Services Ltd Dublin 4
(0001) 685755

Irish Micro Computers Ltd Dublin 2
(0001) 763201

NEXOS

Tomorrow's Office Systems-Today.

• Circle No. 276

**NEW
LOW PRICES!**

***FREE
FLOPPY DISC**

****FREE
DATA DESK**



**CPS Data Systems
is not just a hardware shop.
Our name means what it says**

Whilst we have a fine reputation for a wide range of computer hardware WE ALSO OFFER ALL THE SERVICES you would expect from one of the longest established companies in the microcomputer industry.

- Systems Analysis**
- Programming**
- Personnel Training**
- Installation and Commissioning**
- Total Engineering back-up**

Ring us to find out more about any of these essential services.

Our hardware deals are:-

Commodore micros

at competitive prices e.g. 8032—for £820.00 + VAT
32K 4000 series CPU £555 + VAT

Qume Daisy Wheel Printers

For volume output of letter quality from £1,550 + VAT

New Olympia Scripta

Daisy Wheel Printer from £806 + VAT

Sanders Media 12/7

The unbelievable letter quality printer that can change type size and style as it prints—has to be seen to be believed.
From £2,390 + VAT

Ask about our special deals on demonstration equipment—at well below list prices.

* **Before you buy!** ring us and if we can't match or better the price you already have we will send you free a 5¼" mini floppy discette with our compliments

* *Free with all orders over £2,000.00



CPS (DATA SYSTEMS) LTD

Third Floor, Arden House,
1102 Warwick Road, Acocks Green,
Birmingham B27 6BH
Tel: 021-707 3866

A member of the CPS Group

• Circle No. 277

£250.00

Winter Stock Clearance Sale

(LIMITED OFFER)

80 COLUMN DOT MATRIX PRINTERS

SPECIFICATION



Matrix 7 x 5
150 c.p.s.
70 lines/min.
Uni-directional
220/240 v 50 Hz.
Mains supply
Interfaces
available
at extra cost

Please send cheque/postal order for

£299.00

(includes VAT and packing and carriage)

TO:

INTEGRATED SUPPLIES

Unit C, Britannie Trading Estate, Hayes, Middx.

• Circle No. 278

**CROYDON COMPUTER
CENTRE**

Part of the Zero One Electronics Gp.

YOUR BEST BUY FOR PRINTERS!

Just look at these prices:

OKI MICROLINE 80

Pin feed only, centronics interface complete with paper rack.

£299

SEIKOSHA GP80

The cheapest on the market, centronics interface pin feed.

£199

Z 800

Rugged and reliable. Friction and tractor feed complete with RS232, Centronics and IEEE interface.

£319

ANACOM 150

High speed (150cps) 9x9 dot matrix with centronics interface. 3-15" tractor feed.

£695

All printers serviced on our premises.

Many more Spring offers, eg Video Genie £299. We will be happy to quote for all your computing requirements, machines printers paper etc. Please send SAE for details or call in.

All prices exclude VAT and carriage.

CROYDON COMPUTER CENTRE

29A BRIGSTOCK RD, THORNTON HEATH, SURREY CR4 7JJ

01-689 1280

Unsure of what to buy?

Why not hire and try?



• Circle No. 279

MICROS

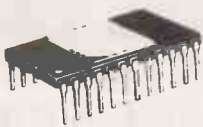

Micros, memory and support

MC1489	85	74S287	2.60
MC1488	85	74S288	2.60
MC14411	11.85	74S471	4.85
MC14412	11.85	74S472	11.85
1702	2.95	74S474	1.80
2101	2.95	81T28	1.80
2102	2.32	81T28	1.80
2111	2.32	81T95	1.80
2112	2.32	81T97	1.80
2114	3.45	81T98	1.80
2114L	3.75	SC/MP2	9.95
2142	10.40	80B0	5.49
2376	11.60	80B5	11.95
2513	6.50	80B6	89.00
2516(5v)	13.95	81S4	11.60
2532	29.00	81S5	12.60
2708	6.80	81LS95	1.30
4027	2.85	81LS96	1.30
4116	4.85	81LS97	1.30
4118	14.95	81LS98	1.30
5204	7.95	8212	2.45
57109	12.43	8216	2.50
57161	9.85	8224	2.50
6011	4.95	8228	4.20
6402	4.95	8251	4.95
6502	7.95	8253	10.95
6520	4.80	8255	4.95
6522	7.95	8257	10.95
6532	8.50	8259	11.95
6545	17.50	8678	12.95
6576	14.85	8602	2.20
6800	7.95	96364	10.95
6802	12.49	Z80-2mHz	7.50
6805	19.95	Z80-PIO	6.95
6810	3.95	Z80-CTC	6.95
6821	4.50	Z80-4mHz	8.95
6845	19.50	Z80-PIO	7.50
6850	3.95	Z80-CTC	7.50
6852	5.95	Z8000	120.00
74S00	5.80	ADC0B17	14.47
74S04	8.50	DG300	3.80
74S201	3.95	F8	9.95
74S188	2.60	F8SMI	9.95
74S262	9.95		

SOFTWARE

CP/M*

DISK WITH /MAN MANUAL
Available on 8" IBM format & 5 1/4" for TUSCAN & TRITON

TCL SOFTWARE	
TCL Disc Basic	£55/£9
TCL Pascal	£120/£9

MICROSOFT	
Basic-80	£155/£15
Basic Compiler	£195/£15
Fortran-80	£205/£15
Cobol-80	£325/£15
Edit-80	£45/£10
Macro-80	£75/£10

MICROPRO	
Word-Star	£255/£15
Word-Star/Mail-Merge	£315/£15
Data-Star	£195/£25
Word-Master	£75/£15

DIGITAL RESEARCH	
CP/M 1-4	£75/£18
CP/M 2-2	£95/£18
MAC	£55/£10
SID	£45/£10

OTHERS	
KISS	£190/£15
SUPER SORT I	£125/£15
C BASIC 2	£75/£10
Z80 Dev Pack	£50/£12
ZSID	£60/£7
POSTMASTER	£85/£10

MEDIA	
5 1/4" S/Sided D/D	£3.50
" per 10	£29.50
8" S/Sided D/D	£4.50
" per 10	£35.00
C12 Data Cassettes	50p

MAIL ORDER

TEL & MAIL ORDERS ACCEPTED



74LS00

LS00	13	LS366	85
LS01	13	LS367	85
LS02	15	LS368	85
LS03	16	LS373	180
LS04	20	LS374	180
LS05	23	LS375	180
LS08	25	LS377	180
LS09	27	LS378	185
LS10	20	LS379	215
LS11	32	LS386	85
LS12	32	LS390	140
LS13	33	LS393	140
LS14	76	LS395	210
LS15	40	LS396	180
LS20	24	LS398	275
LS21	32	LS399	230
LS22	40	LS445	140
LS26	48	LS447	185
LS27	45	LS490	180
LS28	48	LS668	105
LS28	44	LS669	105
LS32	30	LS670	270
LS33	39		
LS37	39	4000	18
LS38	28	4001	18
LS40	40	4002	24
LS42	80	4003	92
LS47	85	4007	22
LS48	120	4008	82
LS49	120	4009	40
LS51	25	4010	46
LS54	30	4011	24
LS55	70	4012	24
LS63	160	4013	45
LS73	40	4014	85
LS74	40	4015	85
LS75	45	4016	82
LS76	45	4017	82
LS78	45	4018	82
LS83	105	4019	82
LS85	105	4020	88
LS86	45	4021	88
LS80	80	4022	85
LS91	125	4023	25
LS93	75	4024	76
LS95	115	4025	25
LS96	180	4026	180
LS107	45	4027	48
LS109	76	4028	82
LS112	80	4029	105
LS113	85	4030	105
LS114	49	4033	175
LS122	70	4034	210
LS123	85	4035	125
LS124	180	4040	105
LS125	80	4041	80
LS126	80	4042	80
LS132	95	4043	95
LS133	30	4044	95
LS136	55	4046	130
LS138	70	4047	98
LS139	80	4049	45
LS145	120	4049	45
LS148	175	4051	48
LS151	95	4052	80
LS153	85	4053	80
LS155	95	4054	130
LS156	95	4055	135
LS157	75	4058	28
LS158	85	4059	28
LS160	120	4070	30
LS161	95	4071	25
LS162	110	4072	25
LS163	100	4073	25
LS164	115	4075	25
LS165	165	4075	99
LS166	175	4078	30
LS168	210	4081	28
LS169	210	4093	88
LS170	288	4502	125
LS173	105	4507	80
LS174	147	4508	80
LS175	110	4510	88
LS181	285	4511	150
LS190	120	4512	65
LS191	120	4514	195
LS192	125	4515	288
LS193	125	4516	120
LS194	125	4518	105
LS196	125	4519	70
LS198	120	4520	115
LS202	345	4521	250
LS221	120	4522	180
LS240	225	4526	150
LS241	225	4527	180
LS242	232	4528	120
LS243	232		
LS244	225		
LS245	360		
LS247	135		
LS248	135		
LS249	135		
LS251	130		
LS253	130		
LS257	115		
LS258	120		
LS259	180		
LS261	450		
LS266	75		
LS273	180		
LS275	320		
LS279	88		
LS280	280		
LS283	190		
LS290	130		
LS293	130		
LS295	215		
LS298	215		
LS299	420		
LS324	200		
LS325	320		
LS326	330		
LS327	315		
LS352	185		
LS353	185		
LS355	85		

REGS

103	+va
7805	145
7812	145
7815	145
7818	145
7906	220
7912	220
7915	220
7918	220
7805	145
7812	145
7815	145
7818	145
7824	80
7905	85
7912	85
7915	85
7918	85

74XX

74CXX LINEARS
Many other types in stock. Tel for details

WE HAVE MOVED

TO OUR NEW CENTRAL LONDON SHOWROOM
59/61 THEOBALDS RD, WC1 TUBE HOLBORN.

FLOPPY DISK DRIVES



We sell all you need cased or uncased Cables & connectors Brand new fully guaranteed

Single 5 1/4" Drive	£195
Single 8" SA800	£395
Dual 5 1/4" PSU	£59
Dual 8" PSU	£76
Dual Cabinet & PSU 1x8"	£565
Dual 8" Drive Unit	£945
Dual 5 1/4" Drive Unit	£440

VIDEO TERMINAL



24x80 display Pentland Video Terminal full features professional terminal Full details on request Price £595

S100 CARDS



NEW LOW PRICES

16K STATIC with no RAM(2114)	£ 62	£ 82
8K RAM	£ 109	£ 130
16K RAM	£ 157	£ 178
8K static (16x2114 chips)	£ 48	
64K DYNAMIC (4116)		
with 16K RAM	£ 149	£ 165
with 32K RAM	£ 189	£ 205
with 48K RAM	£ 229	£ 245
with 64K RAM	£ 269	£ 285
16K upgrade 8x4116	£ 40	

16/32K EPROM CARD Without EPROMs 2708/2516	£ 63	£ 89
FDC DOUBLE DENSITY Double Density for 5 1/4" or 8" Drives	£ -	£ 195

VAT

ALL OUR PRICES EXCLUDE VAT & P/P

CENTRONICS 737 PRINTER



Uses any paper roll, fanfold, single sheets, 96 character ASCII, 7 x 7 dot matrix, 50 CPS, RS232 or parallel I/O

OK TOOLS

Full range of wire wrapping accessories & boards & dip jumpers etc. Visit our showroom or send for our catalogue.

VERO

S100 prototyping boards and full range of accessories.

BOOKS

Complete range of microcomputer books and magazines on sale in our showroom.

CATALOGUE AVAILABLE

Catalogue available. Send 50p & S.A.E. (A4 size).

TUSCAN S100

A Z80 based S100 Computer

Single board will hold up to 8K RAM, 8K ROM, Video interface Z80 processor - I/O and cassette interface. 5 spare S100 expansion sockets for memory/disc expansion. System monitor resident BASIC or CP/M system option. All components available separately or ready-built
NEW LOW PRICES
TUSCAN MAIN BOARD KIT ONLY £235 + VAT
SAE FOR DETAILS



TRITON SINGLE BOARD PERSONAL COMPUTER

8080 BASED SINGLE BOARD system with EUROCARD EXPANSION

Complete Kit incl. PSU/Case/Keyboard £286
Expansion Motherboard Kit £ 50
8K (2114) RAM Card Kit £ 97
8K (2708) ROM Card Kit £ 97
Expandable up to CP/M
Disc System. SAE for details



TCL PASCAL FOR PET & CP/M systems

Put Pascal on your PET now
Pascal conversion ROM £ 20
Pascal manual £ 9
Complete package including compiler £ 120



Edge Connectors S100



DIP Switches

4 way	£1.20
7 way	£1.75
8 way	£1.80

DIP Plugs

14 DIL	£ 65
24 DIL	£ 2.20
40 DIL	£ 3.60

DIP SOCKETS (TEXAS)

Low Prof	Wire Wrap	2x 6 way - 1.75
8pin 10p	26p	2x12 way - 3.00
14pin 12p	36p	2x15 way - 3.20
16pin 13p	42p	2x18 way - 3.50
18pin 16p	60p	2x22 way 3 203 65
20pin 22p	90p	2x25 way 3.60
22pin 25p	-	2x30 way 4.15
24pin 30p	65p	2x36 way 4.75 3.90
28pin 36p	90p	2x40 way 5.00
40pin 40p	1.10p	2x43 way 5.50 4.60

Zero Insertion Force Sockets

16 way	£4.95
24 way	£6.00
40 way	£9.50

D-Types

25W Male	£2.80
25W Female	£3.80
25W Cover	£1.80

Edge Connectors

156	
156	
156	

COMPUTERS

Decisions! Decisions! Who do you turn to?

Up to now there hasn't been anybody willing enough to give you impartial advice, on which type of microcomputer and/or wordprocessing system is right for your business. We at Petalect have made it our business to give you that help. A study of the market has meant that we can offer you a wide selection of systems to meet most applications, at a cost that is not going to burn a hole in your pocket.

They range between £1,000 - £15,000 and include the best known names — Commodore, Sharp, ACT, Hewlett-Packard and Apple. All backed by our reliable after-sales service. So before you make a decision, chat with us first.



Make the right choice, right from the start.

32, (P), Chertsey Road, Woking, Surrey GU21 5JE Tel: Woking 69032/21776

• Circle No. 281

CRYSTAL ELECTRONICS CC ELECTRONICS

THE SKY'S THE LIMIT FOR YOUR SHARP MZ80K with SHARP CP/M 2.21 (XTAL)

CP/M is the trade mark of Digital Research.

This sophisticated interactive program development system will give your home computer BUSINESS/INDUSTRIAL potential.

Basic CP/M facilities include:

- Dynamic file management
- General purpose editor
- Fast assembler
- Advanced debugging utility

YOUR SHARP CP/M 2.21 (XTAL) PACKAGE INCLUDES

- Hardware modification (if fitted by a SHARP dealer does NOT break the guarantee)
- SHARP CP/M 2.21 (latest version) on disc
- XTAL Monitor and Operating system
- 7 Digital Research manuals
- CP/M Handbook (by RODNAY ZAKS)
- 12 months guarantee and up-dates

IF YOU ARE A SHARP MZ80K OWNER, CP/M 2.21 (XTAL) IS A MUST FROM £200.00

Ask your SHARP dealer for further details or contact CRYSTAL ELECTRONICS

CP/M SOFTWARE HOUSES—XTAL CAN HELP YOU ESTABLISH YOUR SOFTWARE ON THE SHARP

Members of Computer Retailers Association & Apple Dealers Association

Shop open 0930-1730 except Saturday & Sunday

40 Magdalene Road, Torquay, Devon, England. Tel: 0803 22699

Telex 42507 XTAL G

Access and Barclaycard welcome.



• Circle No. 282

BASIC INTEGER COMPILER FOR COMMODORE SYSTEMS

- 50-150 times speed of Commodore Basic.
- Any length variable names.
- Single dimension string and integer arrays.
- Full Integer arithmetic & logical (1 byte variables) for extra speed.
- Code & Data can be set to reside anywhere in memory.
- Many facilities for interface with Commodore Basic programmes.
- New commands can be added to Commodore Basic automatically using WEDGE statement.
- Several extra low-level commands for precision I/O programming, eg DELAY, SETBIT, MOVE, etc.
- Automatic insertion of code into interrupt routine.
- Variables can be individually set to reside at any location allowing direct access to page zero I/O ports, etc.
- Full logical file handling.
- Compiling speed of 3 lines per minute.

Suite includes resident compiler, disk compiler, editor, loader and debugger. Editing environment and language similar to Commodore Basic. Produces ready-to-run 6502 Machine Code.

Detailed Manual £7.50 inc. VAT Compiler: 3000 series £150.00 inc. VAT
8000 series £150.00 inc. VAT

Oxford Computer Systems

5 Oxford Street Woodstock Oxford OX7 1TQ Telephone: Woodstock (0993) 812838

• Circle No. 283

SOFTWARE FOR CP/M[®]

HIGH QUALITY SOFTWARE - WITH HIGH QUALITY SERVICE

★ WORDSTAR ENHANCEMENTS

- ★ VDU with Customised keys £645
- ★ Daisywheel printer 60cps £1290
- ★ I/O Master interface board for S100 systems from £100

WORDSTAR - Professional word processing software. On-screen formatting, wordwrap, pagination, line and character count on view. Micro-justification on daisy-wheel printer. Search and replace. Block/paragraph manipulation. External file read/write. Background printing during editing etc.	£250	MICROSOFT BASIC COMPILER	£195
MAIL-MERGE - Powerful Wordstar enhancement for file merging and document personalisation.	£65	MICROSOFT FORTRAN COMPILER	£270
DATASAR Screen orientated system for Data Entry, Retrieval and Updating.	£175	MAGSAM - Versatile easy to use Keyed File Management System for Microsoft Basic or CBASIC.	£130
SUPERSORT - Sort, merge and selection program.	£125	CIS - COBOL - ANSI' 74 implementation to full level 1 standard. Supports random, indexed and sequential files, features for conversational working, screen control, interactive debugging, program segmentation etc.	£425
CONFIGURABLE BUSINESS SYSTEM (CBS) - Unique information management system with user definable files, powerful report generator, menu-driven for ease of use. No programming experience necessary!	£225	FORMS-2 - Automatic COBOL code generator for screen formats.	£100
ACCOUNTING PACKAGES by Median - Tec: PAYROLL, SALES, PURCHASE, NOMINAL Specially developed by UK software house to exacting specifications. Written in Microsoft Basic each package may be customised by end user, all are widely used. Ledgers are open item. Payroll caters for weekly and monthly pay.	£500	PASCAL-Z	£235
PROJECT COST CONTROL/JOB ACCOUNTING - A comprehensive set of programs to monitor budgets, account for expenditure and project completion etc. Ideally suited for contractors. Written in CBASIC-2.	£150	STRUCTURED BASIC - Relocatable compiler	£140
STATISTICS PACKAGE - Over 25 routines including Regression & ANOVA	£100	CBASIC-2 - Extended Disk Basic pseudo compiler and run-time interpreter.	£75
MATHS PACKAGE - Over 40 easily used routines.	£100	SELECTOR III - C2 - Information management system written in CBASIC-2 Maintains multi-key data base files and produces sorted formatted reports. Package includes simple application programs.	£185
IBM - CP/M COMPATIBILITY - Powerful utility to transfer data to/from IBM machines in standard disk format.	£110	SELECTOR IV - Upward compatible version of III with enhanced reporting.	£300
MICROSOFT BASIC INTERPRETER	£155	BSTAM - Telecomms facility for exchanging files between CP/M computers.	£75
		ASCOM - Facility for communicating with other computers.	£99
		MACRO 80 - Macro Assembler	£99
		CP/M 2.2 - Standard Version 8" Single Density.	£99

Please contact us for availability of other products
All orders must be PREPAID. Add £1 per item P & P (Minimum £1.50) and VAT
CP/M is trade mark of Digital Research

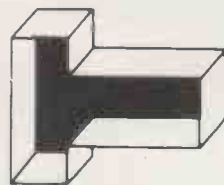

TELESYSTEMS LTD

P.O. Box 12, GREAT MISSENDEN, BUCKS, HP16 9DD

Telephone (02406) 5314

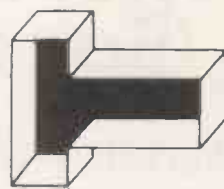

Micro General



MATRIX PRINTERS - FROM £295

Choose from our selection of Matrix Printers for all your low cost printer requirements. There is a model to suit your budget. Printer prices include FREE DELIVERY to U.K. Mainland plus 90 day parts and labour warranty.

MICROLINE PRINTERS

MICROLINE 80 - 80 cps uni-directional printing with Parallel Centronics Interface
 - Serial RS 232 Interface and Tractor Feed Options available. **£295** plus VAT

MICROLINE 82 & 83

- Head life of 200,000,000 characters
- Bi-directional printing with short line seeking
- Centronics Parallel and RS 232 Serial Interface
- 96 ASCII characters and 64 block graphic shapes
- Programmable selection of 4 character sizes
- Programmable vertical forms and tab control
- Self test
- Optional High Speed Serial Interfaces with various communications protocols and buffer sizes

MICROLINE 82
 80 cps. Pin and Friction Feed **£510** plus VAT

MICROLINE 83
 120 cps. Tractor and Friction Feed. Takes up to 16 inch paper. **£799** plus VAT

EPSON MATRIX PRINTER

MX 80 PRINTER - 80 cps bi-directional printing
 - 4 print sizes, bold and emphasised
 - Upper and Lower case with true decenders
 - Vertical and horizontal tabulation
 - Interface boards for PET/APPLE/TRS 80 and RS 232 available. **£345** plus VAT

APPLE & ITT 2020 SALES AND SERVICE

Extra 32K RAM supplied free with every system purchased.

PRINTER PAPER
 11 x 9 1/2 Plain with side perf. 2000 sheets **£18** plus VAT

INTERFACE CABLES Serial: £17.00 Parallel: £27.00 + VAT
 Educational discounts on request.
 Remittance plus VAT please to:-

MICRO GENERAL, 6 The Birchwoods, Tilehurst, Reading, Berks RG3 5UH.
 Tel: 0734 25226

• Circle No. 285

6809 SWTP/GIMIX

UNIX on a MICRO

- * The new standard DEC/PDP operating system is now available on 6809 micros.
- * UNIFLEX is a MULTI-USER/MULTI-TASKING system for up to 12 users.
- * RRL provide the complete system with from 128k to 768k RAM.
- * 2.5 Megabyte floppy disk drives and 16 Megabyte fixed disks.
- * Full range of VDU's, terminals, printers, interfaces etc.

MOTOROLA 6809 COMPUTERS

- * RRL specialises in the EDUCATIONAL and SCIENTIFIC applications.
- * Small systems from 32k with 5" disk drives upwards.
- * PASCAL, FORTRAN, PILOT, BASIC Compiler, LAB-BASIC, Statistical Analysis etc.
- * D-A, A-D converters and special interfaces to solve your problem.

PET & CP/M STATISTICS SOFTWARE

RESEARCH RESOURCES LTD, P.O. Box 160
 Welwyn Garden City, Herts. England
 Tel: (07073) 26633

• Circle No. 286



centralex

A comprehensive range of Microcomputers Equipment, Peripherals, Software and Services for those who value Professional Standards, Guidance and Continuing Support for Hardware and Software.

CENTRALEX-LONDON LTD
 8-12 Lee High Rd, London SE13
 Tel: 01-318 4213/4/5/6/7
 9.30 am - 5 pm Mon to Fri -
 Evenings and weekends by appointment

APPLE
 TEXAS
 MICROPOLIS
 DIABLO
 MICROLINE

PET
 OHIO SCIENTIFIC
 CENTRONICS
 QUME
 HITACHI

ITT 2020
 CROMEMCO
 ANADIX
 DEC
 LEXICON

EXIDY
 MICROSTAR
 INTEGRAL
 DATA GENERAL
 ETC. ETC.

HORIZON
 SHUGART
 TELETYPE
 EPSON

INFORMEX-80 Printer

£399+VAT

Special offer - for a limited period

For PET, APPLE, EXIDY, TRS80, ETC
 A high quality, high speed printer (125 cps) Upper and lower case letters plus graphics as standard
 Interface and cable for TRS80, PET, APPLE or RS 232 £69 + VAT
 Tractor feed option only £39



ALSO Training, Consultancy, Systems Design, Programming and Software

PAYROLL - INVOICING - STOCK CONTROL -
 SALES/PURCHASE LEDGER - VAT - MEDICAL RECORDS -
 EDUCATIONAL & ENGINEERING PROGRAMMES - HOTEL RESERVATION -
 ESTATE AGENTS - BUILDING MAINTENANCE - COBOL - FORTRAN - ETC.

Maintenance Contracts including stand-by equipment during repair periods - Free Delivery Nationwide - Terms arranged - Credit Cards and official orders accepted.

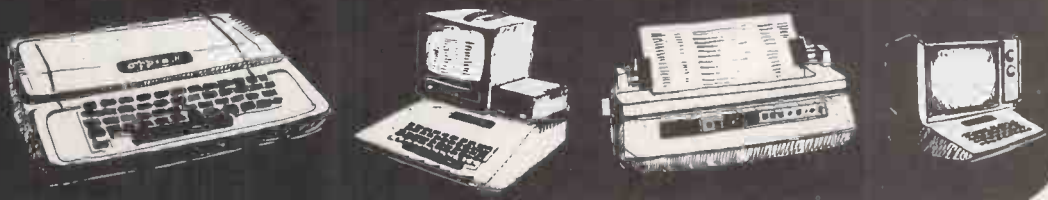
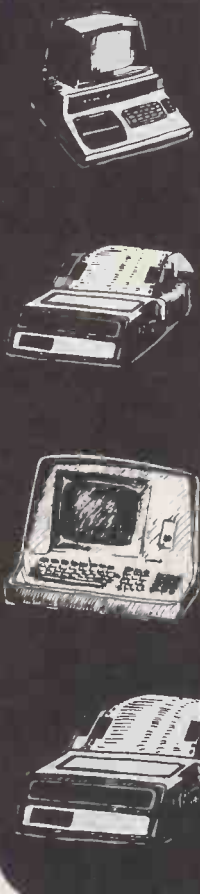

• Circle No. 287

THE ONE STOP COMPUTER SHOP

**BUSS
STOP**

We Supply Systems for Business, Education and Industry —
And We Support Them With Service and Software!

Commodore

2001-8	£379.00	8032	£895.00	KIM1	£93.00
3008	£398.00	8050	£895.00	KIM3B	£96.95
3016	£495.00	8024	£1160.00	KIM4	£65.00
3032	£625.00	8010	£220.00	Toolkit, SuperChip,	
3022	£383.00	Pet Lead	p18.75	Soundbox, Parallel	
3023	£337.00	IEEE Lead	£23.44	and Serial Interfaces	
3040	£625.00	C2N Cass	£49.50	All Ex-Stock.	

Now on demonstration — The NEW PET MODEM, with Supporting Software.

VIDEO GENIE — EG3003 16K RAM, 12K LEVEL II BASIC IN ROM.
TRS80 Compatible 32K VERSION £280.00
£37.00

NASCOM — Phone for latest Details/Prices.

Dolphin Printers — The Superb BD80P now 80/132, chrs/line.
Down to £450.00 While Stocks Last.

The New BD136, The Ultimate Intelligent Matrix Printer — Prints
at 240 Chrs/Sec. £1200.00

RICOH, QUME, NEC Spinwriter etc, Also Available, Please phone
for Prices.

CONSUMABLES C15's Only £4.00 for 10. 10 Verbatim 5¼" Disks
— 35 Track £19.95 — for CBM 3040. 10 Verbatim 5¼" Disks —
77 Track £36.50 — for CBM 8050.

Wide range of Continuous Stationary in stock — Paper, Labels etc.

SOFTWARE — We Sell Only The Best — Wordpro, Wordcraft,
OZZ, Communicator, Medicom — and much more! Plus — A Wide
Range of Books and Manuals for all Machines.

Please phone for carriage charges, all prices + VAT

Photo Acoustics Ltd, BUSS STOP Computer Division

255a St. Albans Road, Watford, Herts. (entrance in Judge Street)

Phone: Watford 40698

58 High Street, Newport Pagnell, Bucks

Phone: Newport Pagnell 610625

• Circle No. 288

New release from SD systems

The MS-20

The ideal Low Cost entry into the world of Micro computing for the serious small business person. For £3200 the MS-20 offers 2 MB floppy disk storage, 4 Mhz. Clock, optional CRT terminal 64K RAM and full compatability with the SD range of equipment.

O.E.M.
enquiries
welcome.



We also supply Texas Instruments OMNI 810 printers with lower case for £1097.00 ex stock.

BARCELLOS Ltd.

Kimberley House, Vaughan Way, Leicester.
Telephone: 0533 26584

• Circle No. 289

MMS

Computer Systems

announces —
**ACCOUNTING BREAKTHROUGH ON
COMMODORE 3000 & 8000 RANGE**

Fully integrated and balancing ledger system

- Sales and Purchases Ledgers
- Open Item
- Large Capacities
- Multi Ledgers
- Multi Companies
- Nominal and VAT Ledgers
- One set of Disks
- Simple to Operate
- Powerful
- Period End Audit Reports

**SEND COUPON TODAY
OR TELEPHONE
JOHN PERCIVAL
0234-40601**

To MMS Ltd.

26 Mill St., Bedford MK40 3HA

Please send details of MICROFACTS to:

Name

Company

Address

PC5/81

• Circle No. 290

LOCAL DEALERS

LONDON

Belmartin Services
194 Union Street
London SE1 0LD
Tel: 01-928 5322

Lion House (Retail) Limited
227 Tottenham Court Road
London W1P 04X
Tel: 01-637 1601

Eurocalc Limited
128/132 Curtain Road
London EC2
Tel: 01-739 6484

Personal Computers Limited
194-200 Bishopsgate
London EC2M 4NR
Tel: 01-626 8121

PROVINCES

Avon

Decimal Business Machines Limited
Decimal House
Thomas Lane
Bristol BS1 6JH
Tel: 0272 214093

Oxfordshire

Alphascan Limited
Little Bourton House
Southam Road
Banbury OX16 7SR
Tel: 029 575 8202

Noteset Limited
34 Tindalls Park Road
Clifton
Bristol BS8 1PR
Tel: 0272 34058

Hyford Business Machines Limited
120 Botley Road
Oxford OX2 0HH
Tel: 0865 723511

Berkshire

The Computershop Group
7-9 Gosbrook Road
Caversham
Reading RG4 8BD
Tel: 0734 481008

South Glamorgan

David Potter Office Equipment Limited
164 Richmond Road
Cardiff CF2 3BX
Tel: 0222 496510

Buckinghamshire

Chiltern Microcomputers Limited
7 Amersham Hill
High Wycombe HP13 6NQ
Tel: 0494 20416

Strathclyde

Turnkey Computer Technology Limited
23 Calderglenn Road
St. Leonards
East Kilbride G74 2LQ
Tel: 03552 39466

Cheshire

McNab and Company
27 Sunfield
Romiley SK6 4PJ
Tel: 061 494 9410

Surrey

T & V Johnson
(Microcomputers Etc.)
Johnson House
75-79 Park Street
Camberley GU15 3XE
Tel: 0276 20446

Cornwall

Diskwise Limited
25 Fore Street
Callington PL1 7AD
Tel: 05793 3780

Warwickshire

Business and Leisure Micro Computers
16 The Square
Kenilworth CV8 1EB
Tel: 0926 512127

Exleigh Business Machines Limited

11 Market Place
Penzance TR18 2JB
Tel: 0736 66577

Gallid Limited

1 Bilton Road
Rugby CV22 7AA
Tel: 0788 74442/3

Hertfordshire

CCS Microsales Limited
7 The Arcade
Letchworth SG6 3ET
Tel: 04626 73301

West Midlands

Camden Electronics
426 Coventry Road
Small Heath
Birmingham B10 0U6
Tel: 021 773 8240

Greater Manchester

Executive Reprographics & Business Consultants Limited
2/4 Oxford Road
Manchester M1 5QA
Tel: 061 228 1637

West Glamorgan

Croeso Computer Services
516 Mumbles Road
Mumbles
Swansea SA3 4BV
Tel: 0792 60624

Merseyside

Currie (Business Equipment) Limited
8 Upton Road
Claughton
Birkenhead L41 0DF
Tel: 051 658 5111

Worcestershire

Arrow Business Computers Limited
Royal House
11 Market Place
Redditch B98 8AA
Tel: 0527 62733

Norfolk

Anglia Computer Centre
88 St. Benedicts Street
Norwich NR2 4AB
Tel: 0603 29652

Yorkshire

Saville Audio Visual Limited
Salisbury Road
York YO2 4YW
Tel: 0904 52011

Switch this data terminal off-line...



...and you've got a daisywheel typewriter.

SCRIPTA £998 + VAT (RO Version £836 + VAT)

Manufactured in W. Germany by **OLYMPIA INTERNATIONAL**

SOLE UK DISTRIBUTOR: **DATAPLUS LTD.**,

- * Does the work of both a data terminal and an electronic typewriter.
- * Saves you hundreds of pounds in machine costs.
- * Full word processing capability.
- * Library of easily-changed daisy typewheels.
- * Optional tractor unit allows continuous feeding of single or multi-part forms.
- * 'Lift-off' and 'Cover-up' correction facilities available.
- * RO version available without keyboard.
- * Contact your nearest dealer or the address below for more detailed information.

DATAPLUS

DATAPLUS LTD.,
39-49 Roman Road, Cheltenham GL51 8QQ.
Telephone 0242 30030 or 37373. Telex: 43594

• Circle No. 291

Do you have financial control of your company?



**When did you last have an up-to-date financial statement?
Do you have effective cash flow management?
Do you get your statements out on time?**

The Financial Controller is the solution to these problems, and is the first of a series of modular programs that form the basis of an integrated business system for the Apple II/Apple III/ITT 2020. All programs in the series will run on 5¼" disk drives, 8" drives and the 10 megabyte fixed disk. From a starting price of around £3500 inclusive of the micro computer system, the Financial Controller offers you Cash flow/budget planning. Balance sheet. Profit and loss statements. Invoicing. Sales ledger. Purchase ledger. General ledger. Payroll. For up to 1000 accounts. All fully integrated.

Available soon: Credit control, costing, stock, order processing, works scheduling, parts explosion, word processing, addressing and mailing, time recording, databased. All fully integrated.

For the solution to your business problems and a demonstration of the Financial Controller, contact your nearest distributor.

London Dalmington W1 01-580 6702 K.A.I. NW4 01-328 3968 The Xerox Store WC1 01-409 0694 The Xerox Store W1 01-629 0694 Bedfordshire Computopia Leighton Buzzard 0525 376600 Berkshire Lynx Computers Windsor 56322 Cambs Q.I.S. Peterborough 47191 Cheshire Systems Integration Altringham 9285784 U Microcomputers Warrington 54117 Cornwall Diskwise Callington 3780 Cumbria Furness Computer Services Barrow in Furness 24621 Essex Compuskill Romford 751906 Computerist Southend 335298 DDP Basildon 728484 Dair Electronics Halstead 472533 Hunt Smees Basildon 21244 Kimfield Chelmsford 64230 Gloucs William-John & Co Stroud 70109 Herts Local Business Technology Hoddesdon 66157 Leics Leicester Computer Services Leicester 708483 Middlesex Leeway Data Products 01-898 4761 Norfolk Anglia Computer Centre Norwich 29652 Nottinghamshire Keen Computers Nottingham 583254 Oxon Micromark Henley on Thames 77926 Rocon Abingdon 24206 Surrey Ferguson West Byfleet 45330 Surrey Micros Godalming 22318 Sussex Datatech Eastbourne 36268 Oval Computers Worthing 44831 Tyne & Wear P.I.P.S. Computer Services Newcastle Upon Tyne 614939 West Midlands Abovo Systems Ltd Coventry 414258 MicroLogic Birmingham 021 550 8036 Worcs Celtip Star Kidderminster 66201 Scotland Peter McNaughton & Assoc East Kilbride 33562 Wales Cardiff Micros Computers Cardiff 64171 David Potter Office Equipment Cardiff 496785 Swansea 462502 Irish Republic CDS Computing Cork 23922 DB Micros Limerick 42733 Tomorrows World Ltd Dublin 776861 South Africa Spartan Microware Johannesburg 47-1883

Systematics

International



Systematics International, Essex House Cherrydown Basildon Essex
Tel: (0268) 284601

• Circle No. 292

Unique in concept—the home computer that grows as you do!

The Acorn Atom

£120

plus VAT and p&p

Special features include

- * FULL SIZED KEYBOARD
- * ASSEMBLER AND BASIC
- * TOP QUALITY MOULDED CASE

NEW!

Colour Encoder for full colour graphics

£21.50



Also available ready-built

£150

plus VAT and p&p

● The picture shows mixed graphics and characters in three colours

The Acorn Atom is a definitive personal computer. Simple to build, simple to operate. A powerful, full facility computer with all the features you would expect. Just connect the assembled computer to any domestic TV and power source and you are ready to begin. (Power requirement: 8V at 800mA). There is an ATOM power unit available – see the coupon below.

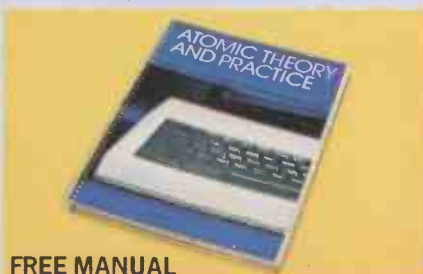

FREE MANUAL

Free with every ATOM, kit or built, is a computer manual. The first section explains and teaches you BASIC, the language that most personal computers and the ATOM operate in. The instructions are simple and learning quickly becomes a pleasure. You'll soon be writing your own programs. The second section is a reference

manual giving a full description of the ATOM's facilities and how to use them. Both sections are fully illustrated with example programs.

The standard ATOM includes:

HARDWARE

- Full-sized QWERTY keyboard
- 6502 Microprocessor
- Rugged injection-moulded case
- 2K RAM
- 8K HYPER-ROM
- 23 integrated circuits and sockets
- Audio cassette interface
- UHF TV output
- Full assembly instructions

SOFTWARE

- 32-bit arithmetic ($\pm 2,000,000,000$)
- High speed execution
- 43 standard/extended BASIC commands
- Variable length strings (up to 256 characters)
- String manipulation functions
- 27 x 32 bit integer variables
- 27 additional arrays
- Random number function
- PUT and GET byte
- WAIT command for timing
- DO-UNTIL construction
- Logical operators (AND, OR, EX-OR)
- Link to machine – code routines
- PLOT commands, DRAW and MOVE

The ATOM modular concept

The ATOM has been designed to grow with you. As you build confidence and knowledge you can add more components. For instance the next stage might be to increase the ROM and RAM on the basic ATOM from 8K + 2K to 12K + 12K respectively. This will give you a direct printer drive, floating point mathematics, scientific and trigonometric functions, high resolution graphics.

From there you can expand indefinitely. Acorn have produced an enormous range of compatible PCB's which can be added to your original computer. For instance:

- A module to give red, green and blue colour signals
- Teletext VDU card (for Prestel and Ceefax information)
- An in-board connector for a communications loop interface – any number of ATOMs may be linked to each other – or to a master system with mass storage/hard copy facility
- Floppy disk controller card.

For details of these and other additions write to the address below.



ACORN COMPUTER 4a Market Hill, CAMBRIDGE CB2 3NJ

Your ACORN ATOM may qualify as a business expense. To order complete the coupon below and post to Acorn Computer for delivery within 28 days. Return as received within 14 days for full money refund if not completely satisfied. All components are guaranteed with full service/repair facility available.

Quantity	Item	Item price inc. VAT+p&p	TOTALS
	ATOM KIT-8K ROM+2K RAM (MIN)	@ £140.00	
	ATOM ASSEMBLED-8K ROM+2K RAM (MIN)	@ £174.50	
	ATOM KIT-12K ROM+12K RAM (MAX)	@ £255.00	
	ATOM ASSEMBLED-12K ROM+12K RAM (MAX)	@ £289.50	
	1K RAM SETS	@ £11.22	
	4K FLOATING POINT ROM (inc. in 12K Version)	@ £23.30	
	PRINTER DRIVE 6522 VIA	@ £10.35	
	(inc. in 12K version) LS244 Buffer	@ £3.17	
	COLOUR ENCODER	@ £21.50	
	MAINS POWER SUPPLY (1.3 amps)	@ £10.20	
		TOTAL	

To: Acorn Computer Ltd., 4a Market Hill, CAMBRIDGE CB2 3NJ
 I enclose cheque/postal order for £ _____
 Please debit my Access/Barclaycard No. _____
 Signature _____
 Name (Please print) _____
 Address _____
 Telephone No. _____
 Registered No: 1403810. VAT No: 215 400 220

PC5/81

● Circle No. 293

● Circle No. 294

Turn your apple® into an Orchard!

Community Computers have pleasure in announcing the demise of the Floppy Disc

Using a Cameo DC 500 Controller and an Ampex DM 440 10 Megabyte Hard Disc Drive, the Apple II grows to give the equivalent storage of 52 Mini Floppies!

With a Cameo Multiplexer, 2-16 Apples can access a single or multiple Ampex Disc Drives

No Software changes required to operate existing programs developed for floppy disc

The Videx Videoterm Board will convert a standard monitor to 80 Character width - **without any floppy disc software**

A further Videx innovation is the Keyboard enhancer which allows the existing Apple Keyboard to be converted to UPPER and lower case

The NEC 12" phosphor green screen enhances the appearance of the Apple and gives really clear definition using the Videx Videoterm



PRICE LIST

Complete System comprising
48k Apple II Ampex DM440 10Mb Disc Drive
Cameo DC500 Controller Centronics 737 Printer
NEC green screen Monitor with Videx Videoterm
80 Character Board Videx Keyboard enhancer
and Magpie Computer desk **£5950**

DRE 8840 240cps printer as illustrated
available at extra cost

'Workpac' Software

Fully integrated with Job Costing suitable for any
industry such as Construction Engineering etc.
available to operate on the above system

For adding to Apple II
Ampex DM440 (5+5) 10Mb Drive
complete with Cameo Controller **£3345**
Cameo multiplexer for 2 Apples **£300**
for operating on additional Apples
price on application
NEC 12" green screen Monitor **£150**
Videx Videoterm 80 char. board **£169**
Videx Keyboard Enhancer **£75**
magpie Computer desk **£275**
(also available for floppy disc drives)

Prices Exclude VAT Carriage Extra
Prices subject to change
Further information from

community
computers

PO Box No3 Petersfield Hampshire GU32 2ER
Telephone East Meon (073 087) 567

Amazing Value – compatible with TRS-80 16K level II

VIDEO GENIE

Now open in Sheffield
MICRODIGITAL
 at **LASKYS**
 53 Leopold Street Sheffield
 Phone: 0742 750971



Fully Supported Hardware

Microdigital are the hardware experts – here's why you should buy your Genie from us.
 ★ Low Price of £280 + VAT. ★ Each computer tested by our engineers before despatch. ★ 12 month parts and labour guarantee. ★ Free delivery within mainland UK. ★ Bona fide official orders welcome. ★ Latest version of Genie.

The Video Genie is a complete computer system, requiring only connection to a domestic 625 line TV set to be fully operational, or if required a video monitor can be connected to provide the best quality display.

The system case contains the Central Processor Unit (CPU), 16,000 bytes RAM memory, the cassette system, a 12,000 byte operating system and BASIC interpreter in ROM, and a full size keyboard, in a stylish case, at a price that makes the Video Genie better value than some "kit" computers.

Applications

The Video Genie System has many uses in all spheres of life, the easy to use BASIC language means that programs are easily written for specific applications, and pre-recorded program tapes are available in great variety.

The system has great scope in the home, sophisticated games programs can introduce the computer age to all the family, who can then progress to writing their own programs in BASIC or even machine code. Software is continuously being developed to aid home budgeting and education.

In a school or college the machine can be used with a large screen TV to allow a whole class to be taught at once.

The powerful Extended BASIC interpreter makes the solution of complex scientific problems simple, and the graphics allow pictorial displays of results.

Prices	Nett	Vat	Total
Video Genie Computer	280.00	42.00	322.00
EG3013 Expander with RS232	215.00	32.25	247.25
EG3013 Expander without RS232	185.00	27.75	212.75
32K Memory Board S100	130.00	19.50	149.50
16K Memory Board S100	95.00	14.25	109.25
Dual Disk Drive (40 track)	410.00	61.50	471.50
2 Drive Cable	17.00	2.55	19.55
4 Drive Cable	32.00	4.80	36.80
Printer Cable	17.00	2.55	19.55
Centronics Parallel Interface for unexpanded Genie	33.00	4.95	37.95
Sound kit	10.00	1.50	11.50
fitting above	5.00	.75	5.75
Lower case kit	35.00	5.25	40.25
fitting above	5.00	.75	5.75

Fully Supported Software



- ✓ Business
- ✓ Programming Aids
- ✓ Personal
- ✓ Custom
- ✓ Games
- ✓ Utilities

7 Years Microprocessor Experience!

Send large SAE (44p) for our current Catalogue of TRS-80/Video Genie software.

A. J. HARDING (MOLIMERX)
 28 COLLINGTON AVE,
 BEXHILL, E. SUSSEX.
 Tel: (0424) 220391
 TTelex: 86736 SOTEX G



24 Hr Telephone Credit
 Card Orders 051-236 0707



Mail Orders to:
 MICRODIGITAL LIMITED
 FREEPOST (No Stamp required)
 LIVERPOOL L2 2AB



Retail Premises at:
 25 BRUNSWICK STREET
 LIVERPOOL L2 0PJ
 Tel: 051-227 2535/6/7

MICRODIGITAL

MOLIMERX LTD

• Circle No. 295

PRACTICAL COMPUTING May 1981

THE EAST MIDLANDS

SUPERBRAIN

CENTRE

£1450
+ VAT FOR
SUPERBRAIN
'SD'
(320k bytes)



£1800
+ VAT FOR
SUPERBRAIN
'QD'
(700k bytes)

THE 'TERMINAL' WITH A DIFFERENCE

A CP/M COMPUTER IDEAL FOR REMOTE DATA PROCESSING
CONNECTION TO DEC COMPUTERS WITH SPECIAL COMMS SOFTWARE NOW AVAILABLE

EX STOCK

- DUAL 4 MHZ Z80 CPUs
- 64K RAM ● 12" CRT
- DUAL DD/DS FLOPPY DISKS
- 25 LINES X 80 COLS SCREEN SIZE

- FULL ASCII KEYBOARD
- S 100 BUS CAPABILITY
- DUAL SYNCHRONOUS/ASYNC RS232 PORTS
- TABLE TOP

MOST CPM LANGUAGES, UTILITIES, AND APPLICATION PACKAGES AVAILABLE
including "SUPERACCOUNTS" · "SUPERPAY" · "SUPERWORD"

SPECIAL

YES NO

- DO YOU believe in INCREMENTAL BUSINESS?
- Well, does your micro support CP/M?
- Does it have a Serial RS232 printer port?
- and, do you use 'WORDSTAR'?
- Does your CUSTOMER have a telex machine?

... IF the answer to all of the above questions is YES, then why not call OCT now and order a 'TELEX-MATE'. TELEX-MATE is a device designed to produce edited telex-tapes 'off-line' from the GPO telex machine. (Ask for the Special Micro-dealer Offer)

Support Facilities available

Additional Packages

'WORDSTAR'

Fully featured word-processing package

£250.00

'DATASTAR'

File creation
File retrieval
& File updates

£195.00

'MAIL MERGE'

For merging names & addresses with letters. Personalised letters are produced without individually typing each one.

£75.00



Office Computer
Techniques Ltd.

Call or write for further details.
Kimberley House, Vaughan Way,
Leicester LE1 4SG.
Telephone Leicester (0533) 28631

PUBLIC COMPANY

requires

PROGRAMMER AND SERVICE ENGINEER

with experience of

EXIDY SORCERER

based in West London with some travel to branches in the South and Midlands.

GOOD SALARY

AND

COMPANY CAR

APPLY WITH FULL DETAILS OF RELEVANT EXPERIENCE TO:

Hamilton Nathan Limited
2 Fitzhardinge Street
London W1H 9PN

• Circle No. 297

apple programmers

HELP HAS ARRIVED

AOPT: Applesoft Program Optimizer is a 2.2K machine language utility that will substantially reduce the size of the program without affecting the operation of the program. **£19.95**

APLUS: Applesoft-Plus Structured Basic is a 4K machine language utility that adds structured programming commands to Applesoft basic. For example 'DO CURVE-FIT'. **£19.95**

CRAE: A co-resident Applesoft Editor. Global changes & finds. Quote (copy) a range of lines. Append, Renummer, Modify. 15 commands in all. **£14.95**

CRAE & MCAT: Editor & Binary utility creating a sorted master catalog. **£19.95**

APPLE PROTECTOR III: Protect your programs against pirating. The protected disks can not be copied by presently available commercial copy programs. **£60**

DOS 3.3: Upgrade to 16 sector diskettes, much improved capacity. **£33**

Add 15% V.A.T. Postage & Packing Free

Write or phone for full catalogue of available software

Contact:

S.B.D. SOFTWARE
15 JOCELYN ROAD, RICHMOND TW9 2TJ
Tel: 01-948 0461 Telex: 22861

• Circle No. 298

it's time you had ...a Bit Pad!

An easy to use digitizer that makes any form of graphics entry simple. It can be used as a menu device or data entry or even for games.

- Bit Pad will interface with almost any micro-computer.
- Bit Pad is a 15sqin digitizer tablet (an 11sqin active area) and a stylus.
- The Bit Pad price includes an RS232 interface (or IEEE 488 or parallel).
- Bit Pad only costs £399 (excluding VAT) Power Supply Optional.

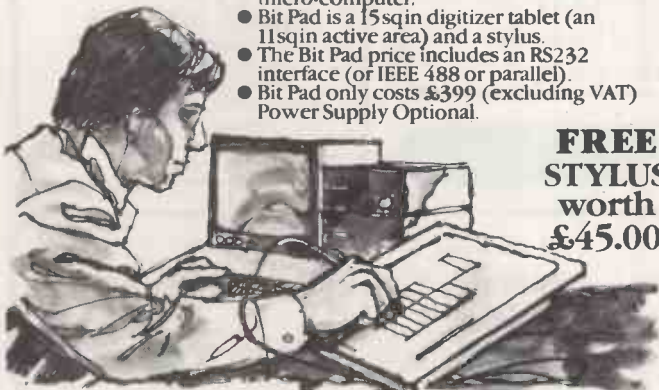

**FREE
STYLUS
worth
£45.00**

Give your computer the flexibility you need, fill in the coupon for more information, or make the coupon into an order, attach a cheque for £459 (including VAT) - it's time you had a Bit Pad!

Summagraphics
Bit Pad



Our Technology...your Success.

For immediate details ring our Action Desk on 0254 676921

Please send me more details/ _____ Bit Pads @ £459 (including VAT)*

Name

Address

GRAPHICS

*Please delete as applicable.

PC 5B

Send to: TDS Ltd, Philips Road, Whitebirk Estate, Blackburn, Lancs. BB1 5TH.

• Circle No. 299

FLOPPY DISK DRIVES FOR TRS 80 AND VIDEO GENIE

DUAL DISK UNITS

2 x 40 TRACK DRIVES **£440**
2 x 80 TRACK DRIVES **£595**

SINGLE DISK UNITS

1 x 40 TRACK DRIVE **£236**
1 x 80 TRACK DRIVE **£315**

DISK DRIVE CABLES

2 DRIVE CABLE **£19**
4 DRIVE CABLE **£30**

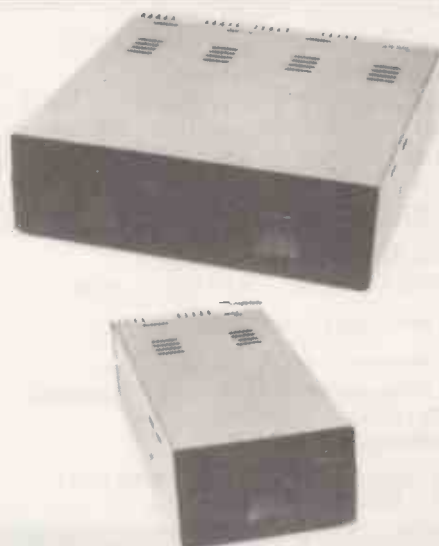

PERCOM DATA SEPARATORS

£20

Plugs into the TRS 80 expansion interface and corrects 'READ/VERIFY' and 'CRC ERROR! TRACK LOCKED OUT!' problems on the inside tracks of any floppy disk system. Comes with full installation instructions — NO SOLDERING, NO CUTTING, JUST PLUGS INTO THE EXPANSION INTERFACE.

Call your nearest dealer for a demonstration:

RADIO SHACK LTD.,
188, Broadhurst Gardens,
London NW6
Tel: 01-624-7174

COMP SHOP LTD., 14, Station
Road, New Barnet, Herts.
Tel: 01-441-2922

COMP SHOP LTD.,
311, Edgware Road,
London W2. Tel: 01-262-0387

MICRO-CONTROL LTD.,
224, Edgware Road,
London W2. Tel: 01-402-8842

**LONDON COMPUTER
CENTRE**, 43 Grafton Way,
London W1. Tel: 01-388-5721

**TRANSAM COMPONENTS
LTD.**, 59-61, Theobalds Road,
London WC1.
Tel: 01-405-5240

N.I.C. 61, Broad Lane,
Tottenham, London N15
Tel: 01-808-0377

ZERO ONE ELECTRONICS,
36, Oaklands Avenue,
THORNTON HEATH,
Surrey
Tel: 01-689-7924

P & J EQUIPMENT LTD.,
3 Bridge Street,
GUILDFORD
Tel: 0483-504801

SEVET TRADING, 14, St.
Paul's Street, Bristol 2
Tel: 0272-697757

PARWEST LTD., 58, Market
Place, Chippenham.
Tel: 0249-2131

COMPUTERAMA LTD.,
5, Cleveland Place East,
London Road, Bath.
Tel: 0225-333232

ENSIGN, 13-19, Milford
Street, Swindon, Wilts.
Tel: 0793-42615

H.C. COMPUTERS LTD.,
541, Durham Road,
Low Fell, Gateshead.
Tel: 0632-821924

**CAMBRIDGE COMPUTER
STORE**, 1, Emmanuel Street,
Cambridge. Tel: 0223-65334

**PORTABLE MICRO-
SYSTEMS**, 18, Market Place,
Brackley, Northants
Tel: 0280-702017

I.C. ELECTRONICS,
Flagstones, Stede Quarter,
Biddenden, Kent.
Tel: 0580-291816

MICRO CHIP SHOP,
190, Lord Street, Fleetwood,
Lancs. Tel: 03917-79511

MICRO CHIP SHOP,
197, Waterloo Road, Blackpool.
Tel: 0253-403122

MICRO CHIP SHOP,
93, Friargate, Preston, Lancs.
Tel: 0772-22669

HARDEN MICROSYSTEMS,
28-30, Back Lord Street,
Blackpool. Tel: 0253-27590

**NORTH WEST COMPUTER
CONSULTANTS LTD.**,
241, Market Street, HYDE,
Cheshire
Tel: 061-366-8624

**HEWART MICRO-
ELECTRONICS**, 95, Blakelow
Road, Macclesfield.
Tel: 0625-22030

KARADAWN LTD.,
2 Forrest Way, Warrington
Tel: 0925-572668

PHOTO ELECTRICS,
459, London Road,
Sheffield
Tel: 0742-53865

GNOMIC LTD.,
46, Middle Street,
Blackhall, Hartlepool
Tel: 0783-863871

EWL COMPUTERS LTD.,
8, Royal Crescent, Glasgow.
Tel: 041-332-7642

CUMANA LTD 35 Walnut Tree Close, Guildford, Surrey, GU1 4UN.
Telephone: (0483) 503121.

*Please add VAT to all prices.
Delivery at cost will be advised
at time of order.*

• Circle No. 300

INDEPENDENT COMPUTER ENGINEERING LTD

CROMEMCO SYSTEMS & SOFTWARE

CP/M 2.2 FOR CROMEMCO — £95

MP/M 1.1 for Cromemco — £350

Cromemco System Zero — £575

S100 Peripherals:

Dump your hard disk to 'reel' tape in 10 minutes —

½" 9-track 1600 BPI IBM/ANSI compatible tape drive

+ controller + software — £2500

Hard Disk Systems — from £2500

Cartridge Disk — from £3950

CALIFORNIA COMPUTER SYSTEMS

S100 Boards and Systems

64K Dynamic RAM (bank select) — £350

ALL PRICES EXCLUDE VAT

Further details, please contact:

ICE Independent Computer Engineering
16/18 Littleton Road, Ashford,
Middlesex TW15 1UQ

TELEPHONE: ASHFORD (STD 07842) 47171

TELEX: 8952042 (DPCUST G)



EPSON MX80 SERIES DOT MATRIX PRINTERS

- * 9 × 9 matrix (true descenders lower case)
- * 80cps bidirectional printing, with logical seeking print head
- * 96 ASCII character set, plus 64 graphics incorporating 4 switch selectable European language options
- * Programmable forms handling
- * 12 different print modes, up to 132 characters per line
- * Operator controls & indicators, self test
- * Options — high resolution graphics, dual friction/tractor feed unit
- * £395 with standard parallel interface (interface options = RS232, Pet, TRS80, MZ80, Apple)

COMPUTER SOLUTIONS TO BUSINESS PROBLEMS — SOFTWARE PACKAGES / HARDWARE
MAINTENANCE / HARDWARE CONFIGURATION & DESIGN

• Circle No. 301

TECPACS

The reliable technical programs for desktop computers

Professional designers, engineers and scientists must carry out a variety of routine calculations in the course of their work. Today, these routine calculations can be automated to save time and cut costs. But for real economic savings, reliable technical software is necessary.

TECPACS are high-quality, technical software packages, written and tested by professionals for professionals. They can be used in your office, no large centralised computing facilities

are needed, and computing experience is unnecessary. With TECPACS, designers and engineers can explore the design alternatives with ease and confidence. Modifications can be made as the program runs, saving further time.

TECPACS are produced by the Technical Software Centre, set up by BHRA Fluid Engineering and NRDC.

TECPACS offer such features as

- Built-in high technical standard
- Easy to use, friendly style

- Data checking facilities
- Trend facilities
- Choice of units
- High-quality presentation of results

TECPACS add another professional to your team. In your office, or in the design office, just switch on, select your TECPAC program disk, and in minutes you have the answers you need.

For further details,
and up-to-the-minute lists
of TECPACS available contact the:
Technical Software Centre
BHRA Fluid Engineering
Cranfield, Bedford MK43 0AJ
England
or telephone Dr Eugene Sweeney on
0234 750 102

Technical Software Centre
tecpac



• Circle No. 302

Computer Hardware at Cash & Carry Prices.

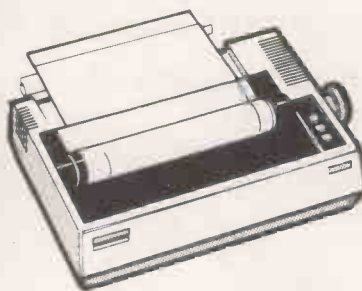
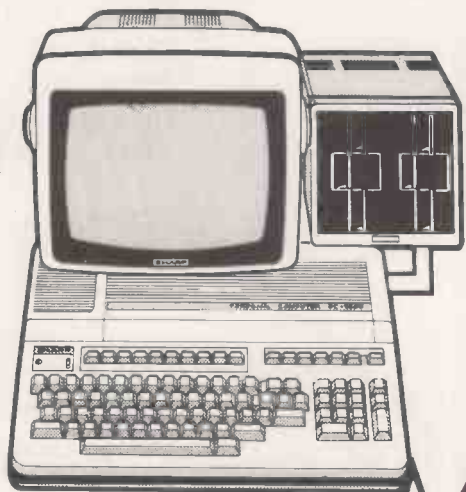

SHARP EQUIPMENT

Model	User Ram	exc.VAT	inc.VAT
Sharp MZ80K	20K RAM	375	431.25
Sharp MZ80K	36K RAM	420	483.00
Sharp MZ80K	48K RAM	460	529.00
Sharp MZ80FD	Floppy Disk	576	662.40
Sharp MZ80P	Printer	372	427.80
Sharp MZ80I/O	Input/Output Unit	87	100.05

The NEW Tangerine Tantal Prestel adaptor £170 plus VAT. HERE NOW! Full colour output connects to any TV. Full GPO approval. Requires GPO 96A jack plug (fitted by GPO). Gives access to massive home computer base. Information from Mortgages to Theatres, Stocks to Holidays.

FREE LEDGER & STOCK CONTROL PROGRAMME WITH EVERY COMPLETE SHARP SYSTEM, i.e. 48K Sharp, Twin Floppy Disk, Printer and I/O Unit

COMMODORE EQUIPMENT

Model	User Ram	exc.VAT	inc.VAT
3008 (4008)	40 Col. PET 8K Mem.	378	434.70
3016 (4016)	40 Col. PET 16K Mem.	462	531.30
3032 (4032)	40 Col. PET 32K Mem.	585	672.75
8032	80 Col. PET 32K Mem.	755	868.25
3040 (4040)	347K Disk	585	672.75
8050	1M Byte Disk	755	868.25
4022	Printer	357	410.55
8024	Printer	975	1121.25
C2N	Cassette	47	54.05

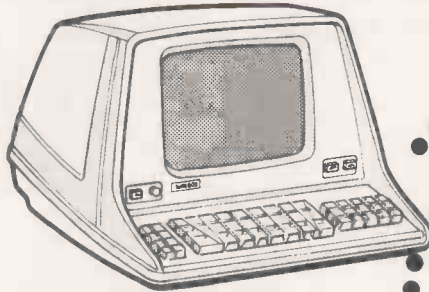
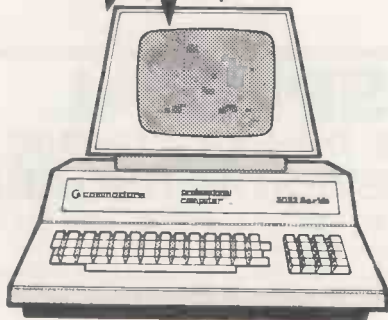

VIC and ATARI equipment – available Mid-May – ring or write for full details.

Every machine sold by Computer Supermarket is fully tested before despatch and is absolutely complete with instruction manual and tape, including free 13 amp plug fitted on mains lead.

All goods sold with full manufacturer's warranty and subject to conditions of sale. Copy available on request. All machines sold are full U.K. Standard.

All prices exclude VAT. FREE delivery anywhere in U.K.

COMPUTER SUPERMARKET

3rd Floor
Douglas House
Queens Square
Corby Northamptonshire
Telephone (05366) 62571
Telex COMPSU 341543/4



• Circle No. 303

MAXIMUM VALUE . . . MINIMAL COST

The Houston Instrument HI-PLOT range of digital plotters:

- Well designed and ruggedly constructed
- Easy to interface via RS232C port
- Easy to use — software listings are available free of charge
- Wide choice of models
- Highly reliable
- Good quality
- 0.1mm step size

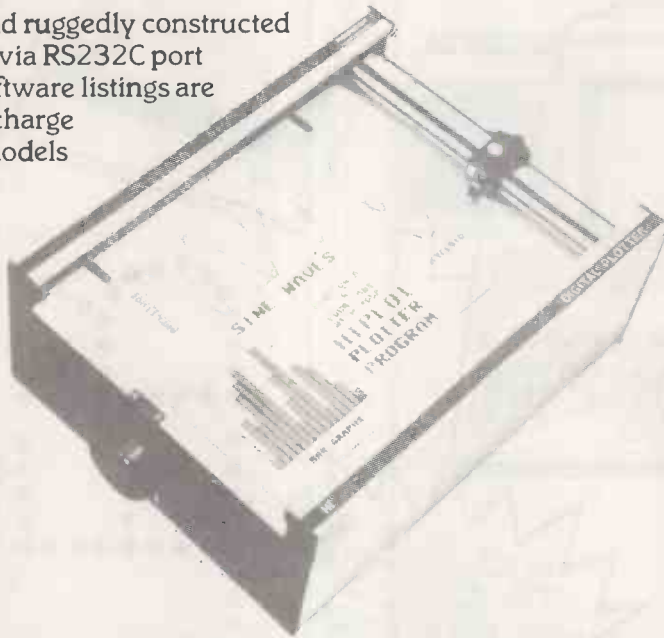

- DMP-2** The standard A4 sized HI-PLOT
£695
- DMP-3** A4 sized but intelligent with remote controls
£800
- DMP-4** Intelligent like the DMP-3 with the same features but with pushbutton controls
£887
- DMP-5** The A3 sized standard HI-PLOT with the same features as the original DMP-2, but with vacuum paper hold
£1080
- DMP-6** A3 sized but intelligent with remote controls
£1185
- DMP-7** Like the DMP-6 but with pushbutton controls
£1271

So now you have SIX good reasons for adding a new dimension to YOUR micro!



Sintrrom Electronics

Complete mini/micro system capability

Sintrrom Electronics Ltd
Arkwright Road, Reading,
Berks RG2 0LS
Tel: Reading (0734) 85464
Telex: 847395

OEM & DEALER ENQUIRIES WELCOME

• Circle No. 304

SPECIAL FROM C.T.S. THE UK'S TOP OHIO DEALER THE NEW SUPERBOARD III

The best value for Money Home Computer available, with the following features:

FULL ASCII KEYBOARD ● 4K RAM EXPANDABLE TO 8K ON BOARD ● 161 GRAPHICS CHARACTERS ● RS232 PORT IN AND OUT (PRINTER INTERFACE) ● CASSETTE INTERFACE ● MODULATOR FOR INPUT TO T.V. ● SPECIAL MODULE GIVING THE MOST STABLE T.V. PICTURE IN THE UK ● EXPANDABLE TO 32K AND DUAL MINI FLOPPIES

SPECIAL FEATURE:

24 characters on 28 lines or 48 characters on 14 lines — Software switchable with our NEW INTAMON MONITOR (Note the OHIO Swap tape is not needed)

THE NEW MONITOR ALSO OFFERS THE FOLLOWING EXTENDED BASIC:

- | | |
|-----------|------------------------|
| Trace ON | Machine Code SAVE |
| Trace OFF | Machine Code LOAD |
| Inkey | Clear Screen |
| GET | Clear window |
| EXIT | Home Cursor |
| SYS | TEXT |
| RUB OUT | GRAPH Format Switch |

This new ROM is suitable for old and new Superboards and can be customised to other screen formats. It is also compatible with all currently available monitors.

PRICES: **NEW SUPERBOARD III WITH MODULATOR**
 NEW INTAMON ROM

£164.95 + VAT
£27.50 + VAT

ONLY FROM:
C.T.S., 31/33 CHURCH STREET, LITTLEBOROUGH, LANCS. Tel: (0706) 79332 or 74342 any time

BUSINESS SYSTEMS

SCHOOL SPECIAL

Up to 16 CIPs (Superboard III in a case) tied into a C8P Host System enabling CIPs to access the Host System's Dual 8" Floppies and Printer. The 32K Host System is a full Business System capable of handling School Records, Accounts etc. Double-sided 8" Floppies are optionally extra, giving over 1MByte on line storage.

OTHER OHIO SYSTEMS

C8P — C3 — C30EM — C3B and C (Hard Disk Systems up to 74 MegaByte) — networking systems.

PRINTERS — ANACOM — MICROLINE — G*80 — CENTRONICS — EPSOM — QUME — OLIVETTI ETC.

VDUs — TVI — VOLKER CRAIG — LEAR SIEGLER — CIPHER ETC.

**RING C.T.S. AND DISCUSS YOUR REQUIREMENTS ON:
LITTLEBOROUGH (0706) 79332 or 74342**

• Circle No. 305

Ohio are now in Britain with their small business computers.

You were wise to wait.

Ohio Scientific – one of the leading suppliers of micro-computers in the U.S. – have supplied more Winchester-based small-business general-purpose micro-computer systems than anyone else in the industry.

Now OS (UK) is here in Britain. Set up in Slough with a full service base, all the equipment you could ask for, more expertise than you'll ever need, and an eagerness to do for small/medium businesses here what they've done for small/medium businesses in America.

Ohio Scientific's C2-OEM is designed to be the cost effective solution to business and industrial applications which can effectively utilize typical micro-computer execution speed. The C2-OEM benefits from Ohio Scientific's years of volume microcomputer production experience yielding an extremely competitively priced medium performance microcomputer. The C2-OEM utilizes the popular 6502 microprocessors operated at 1Mhz clock speed in conjunction with 48K of 450 NS Dynamic RAM memory.

The C3-D mates the electronics of the popular Challenger III triple processor microcomputer system with the cost effective 8" Winchester disk. The C3-D features

the three most popular microprocessors – the 6502A, 68B00 and the Z80A. When operated in the 6502 processor mode, the machine executes instructions approximately twice as fast as competitive microcomputer systems. The C3-D incorporates 52K high speed static RAM, serial I/O port, bootstrap and diagnostic firmware, 8" floppy disk for transport and backup as well as an 8" Winchester. The C3-D comes complete with OS-65U disk operating system which is optimized for use with the Winchester hard disk and includes a fast 9-digit BASIC by Microsoft.

The C3C is the most economically priced 36 megabyte hard disc systems available in the UK. C3C qualities include three processors, 6502, 6800, and Z80 with software control and full multi user and multi tasking facilities, with floppy disk or Alloy Engineering tape drives. C3C is 'state of the art' in microcomputing.

All systems come with fully operational software and languages include BASIC, FORTRAN, AND PASCAL with CP/M (R) on C3 series machines. Complete application software also available.

If you want the biggest backing a small business could ask for, call Alan Davies on (0753) 75915.

OHIO SCIENTIFIC (UK) Ltd*

Middlegreen Estate,
Middlegreen Road,
Langley, Berkshire.
Telephone: Slough
(0753) 75915



* Ohio Scientific (UK) Ltd is a wholly owned subsidiary of American Data Home & Office Computers Inc.

• Circle No. 306

IEEE-488 PET INTERFACES

B200	Bi-directional RS232C serial	£186
Type C	Uni-directional RS232C serial	£120
AP	Addressable parallel for Centronics or Anadex printers	£106
GPI AP	Micro based bi-directional serial interface with buffering Custom GPI software development for special interfacing requirements	£249

All serial interfaces incorporate:

- Software or switched Baud rate selection with 16 different rates selectable
- Crystal controlled Baud rate
- Full RS232C handshake
- 20 mA current loop I.O. option.

All the above interfaces have two modes of code conversion to match print out to the PET screen for either display mode.

Non Addressable parallel TV/Video Interface	£45
We also stock a range of PET connectors	£35



PET SOFTWARE Intercomm . . .

General-purpose Asynchronous communications package . . .

- Emulates a wide range of terminals
- Sends and receives program & data files
- Permits communication with mainframes, networks, other micros, other PETs

Wordcraft 80	£350
Basic Compiler	£375
TCL Pascal	£200
	£120

S100 HARDWARE and SOFTWARE

P&T S100 IEEE controller board with CP/M, North Star or Custom Software	£350
Measurement Systems high quality dynamic memory boards.	

Low cost Micro-processor development aids

8048 programming card	£395
Prom simulator development board	£249
A range of cross assemblers for most popular micros	£85

PRINTERS...PRINTERS...PRINTERS

RP 1600 Daisy Wheel Printer
60 CPS PET, centronics, RS232 interfaces

New . . . RP 1600 with intelligent interface
Bi-directional printing with large buffer

Centronics 737 80 CPS proportionally spaced complete with non-addressable interface for PET or addressable interface	£395 £445
--	--------------

Full range of Hewlett Packard HP-85 and CBM PET Systems

As IEEE-488 interfacing specialists we can provide full technical support and advice on scientific, industrial and word processing application.

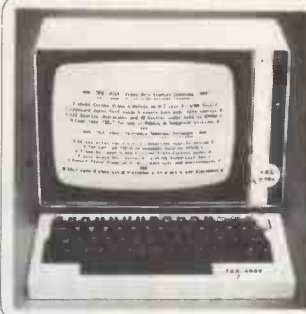

**VIDEO DISPLAY UNIT
TEX VT64 - £299**



**UNIVERSAL KEYBOARD
TEX KB62 - £99**



VT64 + KB62 - £389

- 16 x 64 FULL SCREEN REWRITE IN 0.5 SECONDS.
- 128 CHARACTER U/L SET + FULL CURSOR/SCREEN CONTROLS.
- FOUR-TONE 'BEL'. V24/20mA. 50-19200 BAUD.
- KEYBOARD INPUT PORT ACCEPTS & POWERS MOST TYPES.
- KB62 HAS 464 x 8-BIT KEYCODES IN EPROM.
- 62 KEYS WITH DEDICATED CURSOR & USER FUNCTIONS.
- QUALITY 'FEEL'. ALPHA-LOCK. AUTO-REPEAT.
- QUAD-MODE ENCODING. 2/N-KEY ROLLOVER/LOCKOUT.
- LATCHED DATA. ± STROBE. CONTACTS OF USER KEY.

TEX EPROMPT ERASER - £39 inclusive



- SIMPLE 32-CHIP ¼ HOUR PROCESS ON 200-250V A.C.
- TUBE RUNS COOL AT EXACT WAVELENGTH FOR EPROMS.
- 'EPROMPT GT' MODEL WITH SAFETY INTERLOCK SWITCH ETC. £49 INCL.
- ★ 'TEXTIME' SOLID-STATE 30-MINUTE ERASE TIMER £19 INCL.

★ SPECIAL OFFER: 'EPROMPT GT' + 'TEXTIME' £66 INCLUSIVE.

We are the manufacturers and you can buy direct from us. VT64/KB62 prices exclude shipping and value-added tax. Terms C.W.O. or C.O.D. (add £1) or trade references please. Educational & Public Authorities obtain immediate credit.

All orders and enquiries post-free to:-

TEX MICROSYSTEMS LTD. FREEPOST
ST. ALBANS, HERTS. AL1 1BR ST. ALBANS 64077/TRING 4797 ANYTIME

• Circle No. 308



"THIS BOOK IS EXCELLENT!"

— Clive Sinclair

'30 PROGRAMS FOR THE SINCLAIR ZX-80:1K' is a unique 112 page book which contains 30 programs all designed to fit into your basic 1K version of the Sinclair ZX-80. IN programs which go far beyond anything that has been published the authors show the unique capabilities of the Sinclair ZX-80. The ZX-80 is more powerful than you ever thought!

BLACKJACK — actually contains a full pack of cards, shuffles them, keeps track of the dealer and player card totals, and the money bet, all within 1K.

MEMORY LEFT — an incredible routine, especially useful as it enables you to know exactly how much memory is left, even during the running of a program. This also illustrates USR routines.

DR. ZX-80 — a conversational program with the computer as analyst which uses an ingenious method of storage.

GOMUKU — the computer challenges you to this complex Japanese game. Incredibly this program including display of the 7 x 7 board, fits into 1K; it only does so because it uses the display as memory!

Other programs included are **HORSE RACE**, **LUNAR LANDER**, (with moving spaceship), **NOUGHTS & CROSSES**, **NIM**, **SIMPLE SIMON**, **HANGMAN**, **LIFE**, **MASTERMIND**, **PINCH** and 17 others.

As well as the programs, the book illustrates programming techniques you can use in your own programs — space compression, PEEKs and POKEs, USRs and so on.

AVAILABLE BY MAIL ORDER ONLY £6.95 plus 50p p&p

MELBOURNE HOUSE PUBLISHERS

Orders to: 131 Trafalgar Road, London SE10.

Correspondence: Glebe Cottage, Glebe House, Station Road, Cheddington, Leighton Buzzard, Bedfordshire LU7.

I enclose £7.45 for each . . . copies of '30 programs for the Sinclair ZX-80: 1K' book. (Orders outside the UK — £7.95).

NAME

ADDRESS

Postcode

• Circle No. 307

• Circle No. 309

**NOW WITH
POST OFFICE APPROVAL**

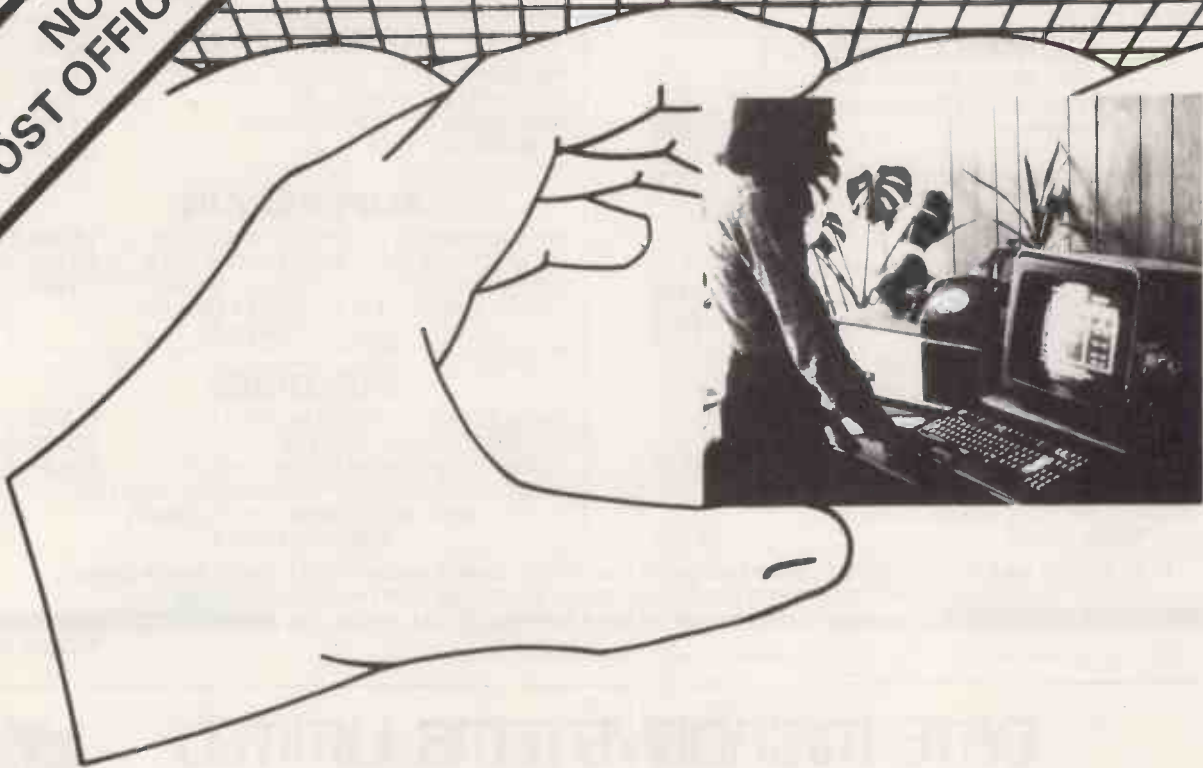

S100 COLOUR VIEWDATA DISPLAY CARD - UHF	£295
S100 COLOUR VIEWDATA DISPLAY CARD - RGB	£244
S100 PRESTEL AUTODIAL MODEM (2 CARDS)	£300
14" COLOUR VIEWDATA MONITOR (RGB)	£325
NORTH STAR VIEWDATA SYSTEM (ILLUSTRATED)	£2605

PRICES DO NOT INCLUDE VAT

**FULL RANGE OF VIEWDATA ITEMS SUPPLIED
CALL FOR DETAILS**

HI·TECH ELECTRONICS

54 HIGH ROAD, SWAYTHLING, SOUTHAMPTON SO2 2JF
TEL 0703 581555 TELEX NO. 47388 HTEL

ADVANCED COMPUTER EQUIPMENT (LEEDS) LTD

95 MEADOW LANE LEEDS 11 TEL 0532 446960

NEW MICROCOMPUTER STORE

NOW OPEN

PRICES SHATTERED

COMMODORE PET

ALL WITH 12 MONTHS WARRANTY

32K PROFESSIONAL KEYBOARD	£575
DUAL DISK DRIVE 347K.....	£625
CASSETTE DECK C2N	£ 50
PRINTER 3022 MATRIX TRACTOR	£375

SHARP Z-80

ALL WITH 12 MONTHS WARRANTY

48K WITH 34K USER RAM.....	£474
36K WITH 22K USER RAM.....	£422
20K WITH 6K USER RAM.....	£380
DISK DRIVES, PRINTERS ETC.	

PRINTERS

BD80/132 BI DIRECTIONAL MATRIX	£425
IEEE PARALLEL OR RS232 INTERFACE	
RICOH—RP1600 DAISYWHEEL	
SPECIAL PRICE	£1,150

APPLE II PLUS

12 MONTHS WARRANTY

48K AUTO START	£695
DISK WITH CONTROLLER	£345
DISK WITHOUT CONTROLLER	£295
9" MONITOR B/W.....	£ 80

SUPERBRAIN

64K WITH SINGLE DENSITY 320K DISK	£1,550
64K WITH DOUBLE DENSITY 700K DISK ...	£2,150
FULLY INTEGRATED ACCOUNTS PACKAGE .£950	
OPERATING SYSTEM * MBASIC *	
COBOL * FORTRAN	

SUNDRIES

DATA TAPES SUPER QUALITY (10)	£ 4.35
5¼" CERTIFIED VERBATIM (10)	£27.00
PLAIN LISTING PAPER 2000 SHEETS	£12.50
BOOKS * GAMES * PROGRAMS * GALORE	
VISICALC * DESKTOP PLANNER	
SPECIAL OFFER	

PLEASE ADD VAT TO ALL GOODS EXCEPT BOOKS — CASH AND CARRY OR 24HR DELIVERY — YOUR CHOICE
ALL EQUIPMENT IS FACTORY FRESH AND FULLY TESTED IN OUR OWN WORKSHOPS
STANDARD CONDITIONS OF SALE APPLIES TO ALL PRODUCTS

• Circle No. 311

GATE MICROSYSTEMS LIMITED

MICROCOMPUTER SALES + SUPPORT NOW IN DUNDEE + GLASGOW



Announce: —

THE
MICROSOFT

Z80 SOFTCARD

FOR YOUR
APPLE II PLUS

NEWS FLASH!
JUST IN FOR APPLE!
THE NEW DAKIN 5...
AND APPLESOFT
TOOLKIT DOS 3.3
UTILITIES

* Z80 Softcard is a circuit board with a Microprocessor and I/O Circuitry which plugs into any slot (except 0 in your APPLE.

* Z80 Softcard allows you to run CP/M, CP/M based languages and CP/M application programs on your APPLE.

* Z80 Softcard enables you to switch your APPLE back and forth from 6502 processing to Z80 processing via a single instruction.

* Z80 Softcard gives you Microsoft Basic 5.0 on your APPLE.

PRICE **£200.00** EX VAT

GATE MICROSYSTEMS LTD

THE NETHERGATE CENTRE
66, NETHERGATE, DUNDEE DD1 4ER (0382) 28194

GATE MICROSYSTEMS LTD

ABBAY HOUSE, 10 BOTHWELL STREET
GLASGOW G2 6NU 041-221-9372

• Circle No. 312

After the best selling 'Pet Revealed' and 'Library of Pet Subroutines' comes another book from Nick Hampshire **PET GRAPHICS**



The way information is displayed on the screen can make or ruin any program whatever the application. This book shows how you can fully exploit the graphics possibilities of the PET, essential reading for anyone wishing to write good useful programs. The book contains dozens of example programs including a comprehensive graphics package written in machine code (resides in the top 2K of memory). The contents of 'PET Graphics' include: How the PET display works — designing a display format — cursor control in PRINT — using POKE — an introduction to the machine code graphics package (you don't need a knowledge of machine code to use this package, but the full source code listings are given for those interested), among the packages over 30 routines are those to draw — bars, borders, character blocks, reverse field blocks, double density point and line plot, fine density bar plot, block scrolling, scrolled multiple page screen, repeat key and protected screen areas, multiple page displays, macro character generator, etc. — Other sections of the book cover — interactive graphics, with full circuit designs and comprehensive support software for adding a light pen to the PET — simple switch and joystick input devices — a review of add on hardware to give the PET high resolution graphics capability.

Price £10.00

All the programs in 'PET Graphics' are available on CBM format disk price £10.00

Cheques payable to Computabits Ltd.

COMPUTABITS LTD

P.O. BOX 13, YEOVIL; SOMERSET.



INTELLIGENT ARTEFACTS LTD

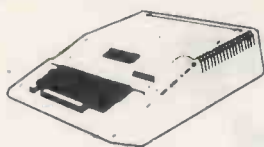

1 YEAR GUARANTEE
THE BLACK
APPLE
 FROM **£549**

- 4016 - 16K - £475 + VAT
- 4032 - 32K - £575 + VAT
- 4040 DISK UNIT - £575 + VAT
- 8032 - 32K - £825 + VAT
- 8050 - "1MB" DISK - £825 + VAT



Latest PETS Large Keyboard and green screen 8K microsoft basic in ROM. Popular easy to use Microcomputer.



- MX80B tractor £359 + VAT
- MX80F/T Friction
- + Tractor £399 + VAT
- OKI Microline 82 £375 + VAT

Epson printers, quiet, bi-directional logic seeking. 9x9 Matrix £ sign Pet + Apple interface, lower case descenders.

- 64K+320K - £1449 + VAT
- 64K+688K QD - £1799 + VAT
- DIABLO 630 Daisywheel
- £1199 + VAT
- WORDSTAR/MAILMERGE
- £379 + VAT



SUPERBRAIN popular professional microcomputer can be used as a stand alone system or as an intelligent terminal. First class word processor terminal. Full system with printer for £2954 + VAT

Extras	SPEECH OUTPUT	£199 + VAT
	PET	
	PET DISK DEBUG	£18 + VAT
	TOOLKIT	£24 + VAT
	CASSETTE	£49 + VAT
	FORTH ON DISK	£49 + VAT

Pet speech output with infinite vocabulary Disk debug a popular aid to disk programming.

Please send me

Name

Address

I enclose cheque/P.O. for £
 (add £15 for P&P for each item of hardware).

INTELLIGENT ARTEFACTS LTD.
 Cambridge Road, Orwell, ROYSTON, Herts.
 Tel: 022-020 689

• Circle No. 314

NEWDOS80 - APPARAT'S DOS FOR THE 80's

- * Up to 4095 bytes per record on disc files
- * Variable - length records
- * 5 or 8 inch disc drives of 35, 40, 80 tracks may be mixed
- * DOS and BASIC command changing
- * Print Spooler provided for concurrent printing and other processing
- * NEWDOS and TRSDOS compatible
- * PLUS MUCH MORE !!!

£65 including detailed manual
BUSINESS SOFTWARE

Contact us to discuss your application

UDMS INFORMATION MANAGEMENT FOR THE NON-PROGRAMMER

- * Powerful, easy-to-use facilities for data storage, update, and reporting
- * Ideal for business applications
- * Extremely flexible
- * Save £££'s on software costs!
- * Versions for TRS80 I and II
- * Comprehensive users manual

Basic Version £75 Full Version £150 Manual only £6.00

MICROLINE-80 PRINTER

Phone for lowest price
 Prices exclude V.A.T. and Postage.

CLEARTONE COMPUTER CONSULTANTS LTD.
 PRINCE OF WALES INDUSTRIAL ESTATE
 ABERCARN, GWENT NP1 5RJ Tel: (0495) 244555

CLEARTONE

• Circle No. 315

ANGLIA COMPUTER CENTRE

MICROCOMPUTERS FOR BUSINESS,
 EDUCATION AND HOME

FOR ALL YOUR BUSINESS, EDUCATION
 & LEISURE COMPUTER REQUIREMENTS!!!

- ACORN ATOM
- APPLE II
- TRS-80
- SHARP
- NORTH STAR
- HORIZON
- TANGERINE
- U.K. 101
- NASCOM
- VIDEO GENIE

+ PRINTERS &
 OTHER PERIPHERALS.

- BOOKS**
- SOFTWARE*
- MAGAZINES**
- STATIONERY***
- BUSINESS &
 INDUSTRIAL
 CONTROL

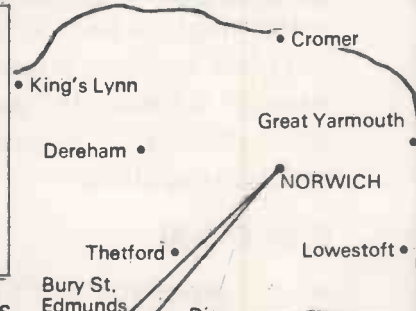

WE ARE HERE!!!
 88 St. Benedict's Street
 NORWICH NR2 4AB
 Tel. (0603) 29652
 24hr. Answering Service.

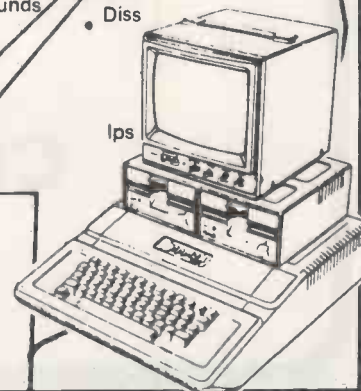

• Circle No. 316

The World beaters from OKI

MICROLINE 80

- UP TO 9.5 INCH PAPER
- 80 cps UNIDIRECTIONAL
- 6 & 8 lpi 5, 10, 16.5 cpi
- BLOCK GRAPHICS
- UK or US CHARACTER SET
- CENTRONICS INTERFACE
- OPTIONAL SERIAL INTERFACE TO 9600 BAUD
- OPTIONAL TRACTOR

£399

MICROLINE 83

- UP TO 15 INCH PAPER
- 120 cps BI-DIRECTIONAL
- LOGIC SEEKING
- 6 & 8 lpi 5, 8, 10, 16.5 cpi
- BLOCK GRAPHICS
- 8 CHARACTER SETS
- CENTRONICS INTERFACE
- SERIAL TO 1200 BAUD
- OPTIONAL INTERFACE TO 9600 WITH 2K BUFFER & XON / XOFF
- IEEE VERSIONS AVAILABLE
- TRACTOR STANDARD

£799

MICROLINE 82

- UP TO 9.5 INCH PAPER
- 80 cps BI-DIRECTIONAL
- LOGIC SEEKING
- 6 & 8 lpi 5, 8, 10, 16.5 cpi
- BLOCK GRAPHICS
- 8 CHARACTER SETS
- CENTRONICS INTERFACE
- SERIAL TO 1200 BAUD
- OPTIONAL INTERFACE TO 9600 BAUD WITH 2 K BUFFER & XON/XOFF
- OPTIONAL TRACTOR

£550

EXTREMELY QUIET & RELIABLE
HEAD WARRANTY
200 MILLION CHARACTERS

TRADE & EDUCATIONAL
ENQUIRIES WELCOME

MICROLINE 80



Special price for limited period only

MICROLINE 83
ALSO AVAILABLE
QUME / TALLY / DEC / CIFER

**Rohan
Computing**

MICROLINE 82

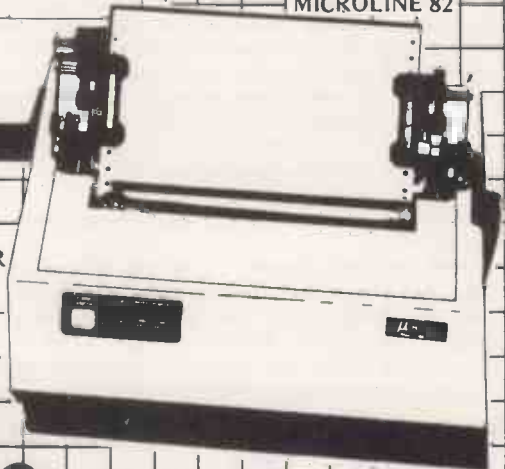

52 COVENTRY STREET, SOUTHAM, WARWICKSHIRE CV33 0EP. Telephone SOUTHAM (092681) 4045 Telex 311640

• Circle No. 317

...for ITT 2020 and Apple Computers

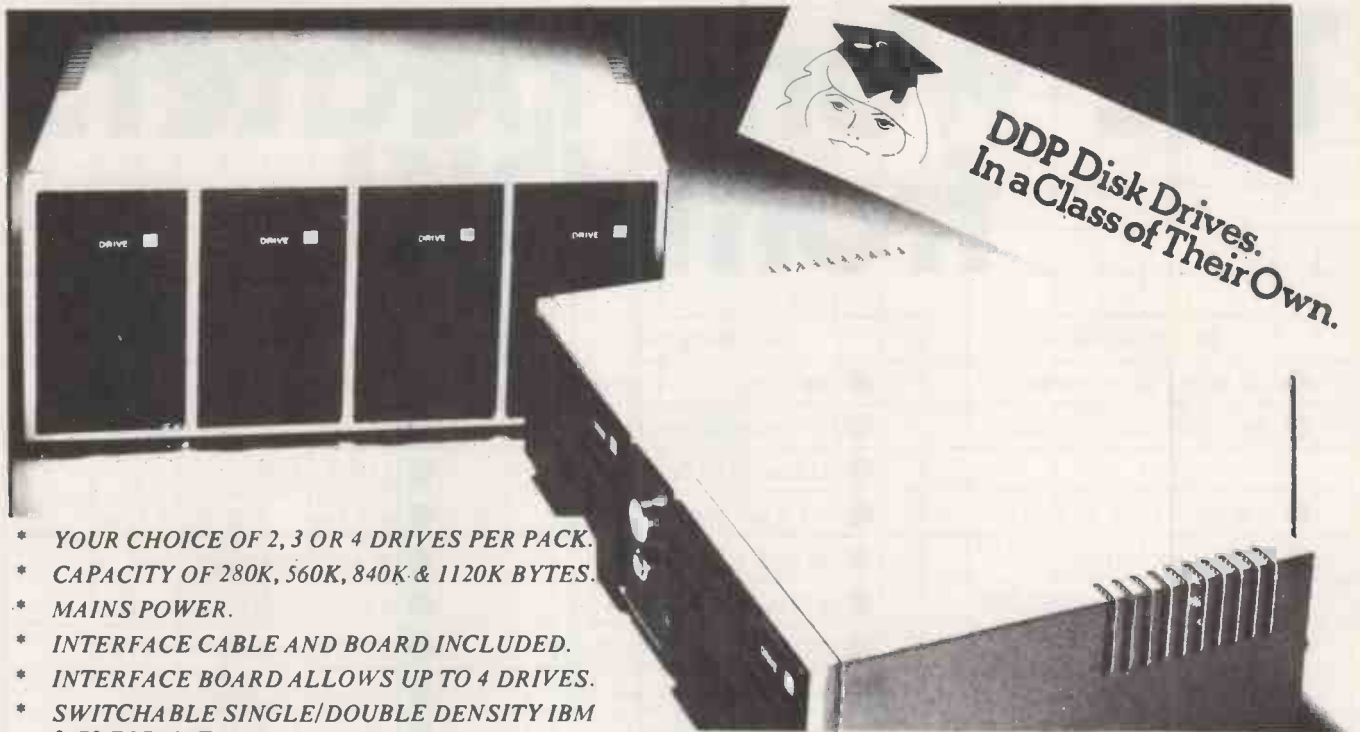

- * YOUR CHOICE OF 2, 3 OR 4 DRIVES PER PACK.
- * CAPACITY OF 280K, 560K, 840K & 1120K BYTES.
- * MAINS POWER.
- * INTERFACE CABLE AND BOARD INCLUDED.
- * INTERFACE BOARD ALLOWS UP TO 4 DRIVES.
- * SWITCHABLE SINGLE/DOUBLE DENSITY IBM 3470 FORMAT.
- * 2 & 3 PACK HAVE LOCKABLE POWER SUPPLY FOR SECURITY WITH LED POWER INDICATORS.



DISTRIBUTED DATA PROCESSING LTD.,
36 Nobel Sq., Basildon, Essex. SS13 1LT.
Tel. Basildon (0268) 728484

• Circle No. 318

aculab

floppy tape,

The tape that behaves like a disc,
For TRS-80 LEVEL II and Video Genie.

Connects directly to TRS-80 Level 2 Keyboard. Operating and file handling software in ROM. 8 commands add 12 powerful functions to Level 2 BASIC. No buttons, switches or volume controls. Full control of all functions from Keyboard or program. Daisy chain multiple drives. Certified digital tape in endless loop cartridges. Reads and writes in FM format at 9000 Baud. Soft sectored with parity and checksum error detection for highly reliable operation—just like discs. Maintains directory with up to 32 files on each tape, tapes may be write-protected. Supports Basic and machine-language program files, memory image and random access data files. 12 character filespecs—: "FILENAME/EXT:d" (d is drive no. 0-7). Automatic keyboard debounce. Full manual with programming examples and useful file-handling routines.

COMMANDS (usually followed with a filespec and possible parameter list).

@SAVE, @LOAD, @RUN —for BASIC programs, machine language programs and memory image files. @GET, @PUT —moves a 256-byte record between a random access file and BASIC's data buffer. @KILL —removes a file from the directory and releases tape sectors for immediate re-use. @LIST —displays file directory along with sector allocation and free sectors. @NEW —formats tape and creates a blank directory.

Master drive with PSU, Manual and a selection of tapes.

For TRS-80 £169-00, for Video Genie £174-00.

Slave drives £125-00. (add £2-00 p.p. + vat).

(Export orders pp charged at cost)



For further
information,
Telephone
0525 371393

aculab Ltd.
24 Heath Road,
Leighton Buzzard,
Beds. LU7 8AB

• Circle No. 319

'TUSCAN' FROM TRANSAM

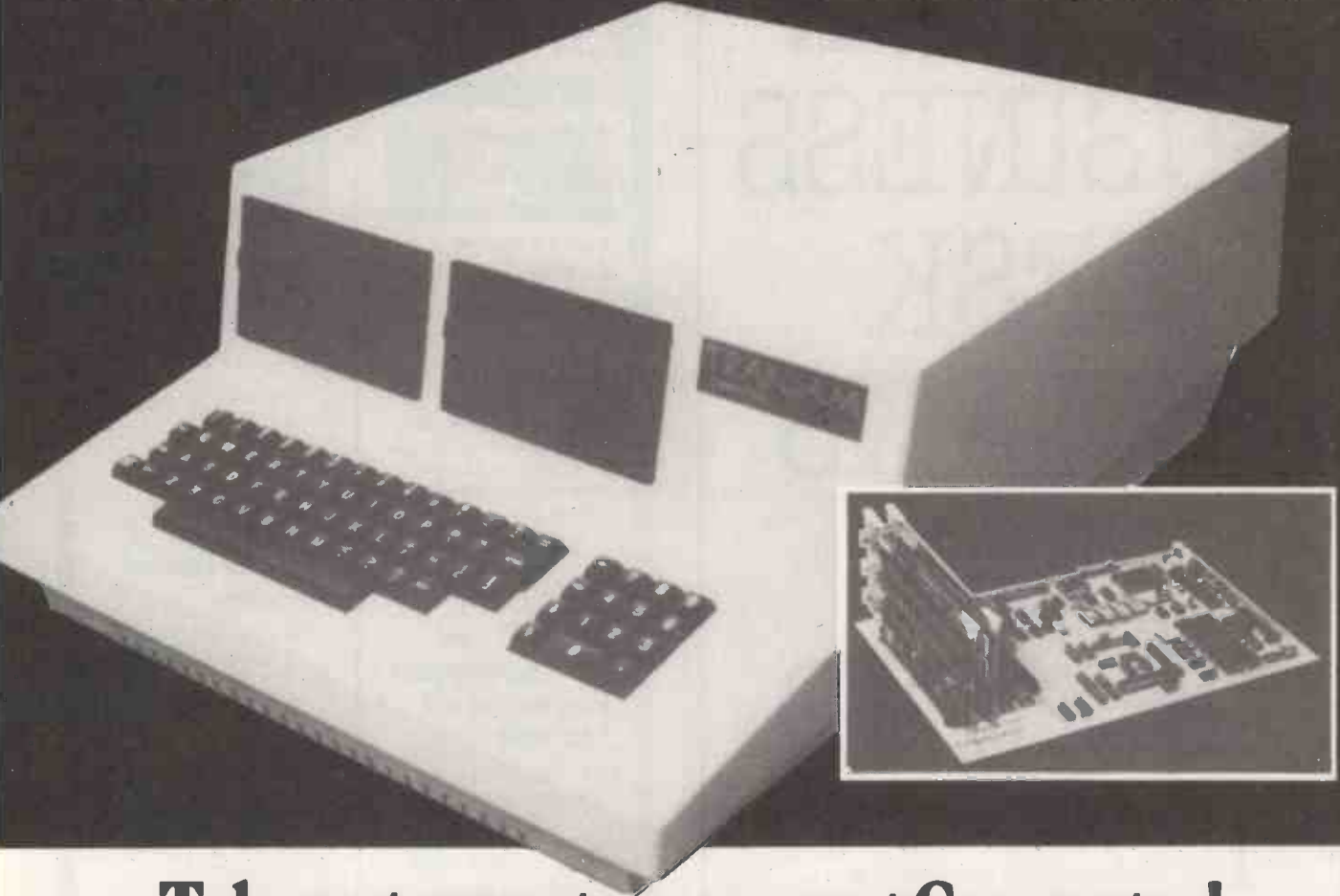

Take a step up to your next Computer!

THE CONCEPT

How many ways are there to build an S100 system? Not many, and all expensive. TUSCAN changes all that.

Five S100 boards on one single board—just for starters. Plus five extra slots for future expansion.

What a combination! Z80 and S100 with the TRANSAM total package of system and applications software.

THE PRICE RANGE

From £235 for complete main board kit to £1481 for 48K assembled with 2 x 5¼" drives.

THE HARDWARE

The first Z80 single board computer with integral S100 expansion. British designed to the new IEEE (8 BIT) S100 specification, the TUSCAN offers total system flexibility. A flexibility available now.

The board holds the equivalent of a Z80 cpu card, 8k ram, 8k rom video and I/O cards with 5 spare S100 expansion slots and offers a price/performance ratio which is hard to beat.

Just compare our price with a commercial S100 ten slot motherboard with this specification.

THE SOFTWARE

TUSCAN offers the user the choice of system monitor, editor, resident 8k basic, resident Pascal compiler or full CP/M disk operating system. All options are upwards

compatible and fully supported with applications software. Both 5¼" and 8" drives are supported in double density.

THE PACKAGE

TUSCAN is available in kit form or assembled. With several hardware and software options to suit your requirements and budget. Attractive desk top case also available holds 2 x 5¼" Drives.

TRANSAM

NOBODY DOES IT BETTER!

Send to Transam Components Ltd., 59/61 Theobald's Road, London WC1.

I am interested in the TUSCAN Z80 based single board computer
NEW LOW PRICES, send S.A.E. for further details.

Name _____

Address _____

Telephone _____

PC5/81

TRANSAM COMPONENTS LTD., 59/61 THEOBALD'S ROAD, LONDON WC1. TEL: 01-405 5240/2113

• Circle No. 320

PAXTON BUSINESS DESK BREAKS NEW GROUND

1. **IT'S COMPREHENSIVE**
Business Desk is a software package providing fully integrated administration facilities including Invoicing, Stock Control, Sales, Purchase and Nominal Ledgers.
2. **IT'S TRANSPORTABLE**
Written in GJS:COBOL Business Desk is designed for ease of implementation on a widest range of computer and peripheral combinations.
3. **IT'S SUPPORTED**
Business Desk comes complete with comprehensive user documentation, demo packages, sales support and proven referrals.
4. **IT'S AVAILABLE NOW!**
New Dealers required in North, Midlands and West.

**THE DEFINITIVE SOFTWARE FOR
MICROCOMPUTER APPLICATION**



Paxton Computers Ltd
26 New Street St Neots
Cambs PE19 1AJ
Tel: (0480) 213785

• Circle No. 321

new practical computing books

sams books

Walter H. Buchsbaum
**Personal Computers
Handbook**

Practical, up-to-date information on buying and using personal or microcomputers is given, including technical features, price considerations, locating defective components, and troubleshooting hardware and software.

£7.75 pb 288 pages
672-21724-4

Andrew Staugaard, Jr.
**6801, 68701 and
6803 Microcomputer
Programming and
Interfacing**

£9.05 pb 352 pages
672-21726-0

Jonathan A. Titus, Christopher
A. Titus and David G. Larsen
8085A Cookbook

£9.05 pb 352 pages
672-21697-3

Jonathan A. Titus, Christopher
A. Titus and David G. Larsen
**TRS-80 Interfacing-
Book 2**

£7.10 pb 256 pages
672-21739-2

Jonathan A Titus
**TRS-80 Interfacing-
Book 1**

£5.80 pb 192 pages
672-21633-7
Published in 1979

prentice-hall books

Mark A. Spikell and
Stephen Snover
Brain Ticklers

Puzzles and Pastimes for
Programmable Calculators and
Personal Computers

£9.05 hb 160 pages
13-081018-5
 £3.85 pb
13-081000-2

David L. Heiserman
**Programming in
BASIC for Personal
Computers**

£11.65 hb 333 pages
13-730747-0
 £5.15 pb
13-730739-X

Don Inman and Kurt Inman
**Apple Machine
Language**

Machine language programming
for the Apple computer is
taught in BASIC in this new book.

£9.70 hb 254 pages
8359-0231-5
 £6.45 pb
8359-0230-7

T.G. Lewis
**Pascal Programming
for the Apple**

£9.70 hb 224 pages
8359-5455-2
 £6.45 pb
8359-5454-4



**Prentice-Hall
International**

Prices are correct at the time of going to press
but may be subject to change.

PCS/81

book orders

These books can be ordered from your bookseller or in case of difficulty from Department 30, Prentice-Hall International, 66 Wood Lane End, Hemel Hempstead, Hertfordshire, HP2 4RG, England.

Please mark the number of books you wish to order in the boxes beside each title and return the advertisement to the address above with your payment.

Name _____
Address _____
I enclose a cheque/P.O. for £ _____

Please add 55p per book for postage and packing. Payment should be made
out to International Book Distributors Please allow 28 days for delivery

• Circle No. 322

apple® II PLUS **48K RAM**

© Apple is a trade mark of Apple Computer Inc., Cupertino, CA. USA.



£595

(subject to availability)

Send cheque or money order for

£692 (including VAT & Delivery in the UK) to:

Trade Enquiries
Welcome

GUESTEL LIMITED

at our new address:

15 Grand Parade, Brighton, Sussex, BN2 2QB.
Telephone: 0273-695264

• Circle No. 323

Printed Continuous Stationery

we can supply printed continuous forms with your company name and logo plus ex-stock single part listing paper in the following sizes:-

depth x width	(in inches)	depth x width
11 x 9¼		13 x 9¼
11 x 9½		8½ x 11½
11 x 10¾		NEW [12 x 9¼ 60 gsm 12 x 9¼ 70 gsm 12 x 9¼ 85 gsm
11 x 9⅞		
11 x 8½		
11 x 12		

multiples in OTC or NCR are available for prices and details telephone:-

David Richards 01-520 8624

David Richards (Printers & Distributors) Ltd 61/63, Hoe Street London E17 4SA

• Circle No. 324

TRS-80 OR VIDEO GENIE? THEN MICRO-80 IS FOR YOU

A monthly magazine full of articles and programs just for the TRS-80. Written by enthusiasts for enthusiasts MICRO-80 is now available in this country. Fill in the coupon and send £1.50 for your sample copy.

To: MICRO-80 (U.K. SUBSCRIPTION DEPT.) 24 WOODHILL PARK, PEMBURY,
TUNBRIDGE WELLS, KENT TN2 4NW

PLEASE SEND MY COPY OF MICRO-80 — I ENCLOSE MY CHEQUE/POSTAL ORDER FOR £1.50
(SINGLE COPY RATE)

NAME

ADDRESS

.....
.....

PC5/81

• Circle No. 325

May the Force be with you...

Businessmen and professional people alike can rid themselves of day-to-day problems and increased workload with a microcomputer.

Just a few tasks a microcomputer could be organising for your company, division or department:-

- Accountants
 - Estate Agents
 - Retailers
 - Insurance Brokers
 - Doctors
 - Dentists
 - Solicitors
 - Architects
 - Engineers
 - Chemists
 - Farmers
 - Bankers
 - Teachers
- to name but a few



- Integrated Accounts
 - Sales Ledger
 - Purchase Ledger
 - Nominal Ledger
 - Sales Forecasting
 - Stock Control
 - Job Costing
 - Estimating
 - Payroll
 - Word Processing
- (automatic compilation, editing and production of repetitive letters and documents).

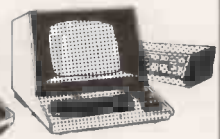
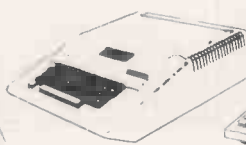

	PET	APPLE II	SHARP	SUPERBRAIN	RAIR
SYSTEM A Basic computer including screen & keyboard	£399	£775	£450	—	—
SYSTEM B As 'A', plus floppy disk drive(s) and matrix printer for small business user.	£1700	£1655	£1750	£2200	£2480
SYSTEM C As 'B', but quality printer for word processing instead.	£2700	£2050	£2250	£2600	£2850
SYSTEM D As 'C', plus hard disk for up to 10,000,000 bytes on line.	—	£5550	—	—	£5350

Prices exclude V.A.T. Rental, Leasing, and/or Maintenance Contracts plus System Software Consultancy available.

Johnson

microcomputers



A member of the T. V. Johnson Group



Johnson House, 75-79 Park Street,
Camberley Surrey. Telephone 0276 20446
48 Gloucester Road, Bristol. Telephone 0272 422061
148 Cowley Road, Oxford. Telephone 0865 721461

● Circle No. 326

1 week courses in Computing for Junior and Senior Management

(or anyone who is interested)

The courses, which can be resident or non-resident, cover all elements of computer appreciation, an introduction to micro computer and mini computer systems and applications packages plus a course in BASIC programming. (There is a micro each so plenty of hands on experience).

Fees for the course:

Non-Resident **£165**

Resident (Includes B&B only) **£198**

The lectures and practical sessions will last for eight hours each weekday and 4 hours on Saturday.

Courses each week throughout the summer commencing Sunday June 14th. Also we can arrange courses to take place at a venue of your choice locally.

For further details ring

HURRICANE COMPUTERS on Worksop (0909) 84047

or send cheque together with details of the number of places required and the Sunday on which the week of your first preference course commences.

• Circle No. 327

NORTH STAR Users..... TAKE THE TEDIUM OUT OF PROGRAMMING WITH THE QDOS NorthStar Utilities Package

(QBS.NSUT)

- Improves Screen Handling
- Simplifies Keyboard Input
- Ensures robust & 'friendly' programs

Built around NS BASIC (rel.5.2), this group of 14 sophisticated functions, simply incorporated at the beginning of your programs, provides:

- Controlled & Checked Numeric, String & Date Input
- Error Handling
- Real Time Clock functions
- Processor Pause
- Cursor Set/Screen Clear functions
- FULLY controlled Disk Copying Program from Basic
- Extra String Processing functions
- With User-Specified VDU Characteristics **£17.00**

QDOS NorthStar Programmer Aids

(QBS.NSPA)

- KREF — (Command) Lists Line Nos. which contain specified BASIC Keywords
- XREF — (Command) Full cross-reference listing of line no. accessed
- QLIST — Prints paged and formatted Program and/or Variable Listings
- QPACK — Compresses BASIC programs for faster execution/smaller memory usage
- QZAP — provides Screen Editing of any Disk-held data
- QCOMP — compares two Programs for differences **£20.00 (Both packages £34.00)**

Fully supported and provided with full documentation on a quality Diskette.

QDOS BUSINESS SOFTWARE 9 Tintern Close Streetly Sutton Coldfield B74 2EL

• Circle No. 328

APPLE COMPATIBLE BOARDS AND SOFTWARE via DIRECT MAIL FROM KEATING COMPUTER

Model	Description	Price (£)	Model	Description	Price (£)
7500A	Wire Wrap Board, up to 25 sixteen-pin or 6 forty-pin sockets.	12.00	7710A	Asynchronous Serial Board, for Paper-Tape Reader, Keyboard, VDU, Printer etc. Baud rates selectable from 50 to 19.2K baud.	95.00
7520A	Extender Board, with top connector.	15.00	7712A	Synchronous Serial Board, for high-speed interface communications.	105.00
7114A	12K ROM/PROM Board, 6 sockets for combination of 2316 ROMs, 2716 EPROMs.	65.00	7720A	Parallel Board, for Paper-Tape, Printer etc. control on/off devices such as low current relays, sprinklers etc.	95.00
7424A	Calendar/Clock Board, 12 or 24 hour formats, adjusts Feb. to 29 days for leap years.	149.00	7728A	Centronics Printer Interface Board, for Centronics-type parallel printers.	119.00
7440A	Programmable Timer Board, 3 independent software-controllable 16-bit timers.	75.00	7379A	Cable for all Centronics, Okidata Mikroline 80 or Microtek MT-88T printers — specify which desired.	17.00
7470A	Analog-to-Digital Converter Board, converts analog voltages to BCD numbers then to ASCII characters for VDU. Use for monitoring thermostats, fluid level in tank, Apple power supply etc.	75.00	7388A	Cable for MPI 88T printer.	17.00
7490A	IEEE488 Interfact Board, up to 15 interconnected controllers, talkers and/or listners for Counters, Signal Generators, Digital Multimeters, Colour Graphics Output Devices etc.	195.00	7811B	Arithmetic Processor Board, floating-point hardware to increase execution speeds and math functions by order of magnitude. Includes interpreter software on diskette for disk drive users.	249.00
			7811C	Arithmetic Processor Board, same as item 7811B except interpreter software on ROM.	249.00

Prices INCLUDE all VAT, Post & Package charges. You pay only actual net prices as quoted. Complete the coupon-order, enclose your cheque/postal order made payable to: Keating Computer.

Big savings on other new products including battery operated hand-held PROM programmer for only £895 complete — ideal for field applications, pocket-size DVM's, Calculators, Interface Cables, Barrier Boxes, VDU's and many more — all at direct-mail prices which save you money. Send £1 for our new catalogue and we'll credit you £5 on your first order. Don't delay — Send Today.

Please ship me:			
QUNTY.	MODEL	PRICE	PAYMENT ENCL.

Allow 30 days for delivery. Documentation includes installation guide, operating instructions, schematics & logic diagrams plus software listings where applicable. All products warranted for 6 months and backed by full money back guarantee if not satisfied.

KEATING COMPUTER WATCH US GROW 42 KNOLL BECK AVENUE, BRAMPTON, NR. BARNSELY, SOUTH YORKSHIRE

• Circle No. 329

KGB MICROS LIMITED

THE PROFESSIONAL ORGANISATION OFFERING
HARDWARE AND SOFTWARE PLUS FULL CLIENT SUPPORT
WHO WISH TO MAKE YOUR BUSINESS OUR BUSINESS

SUPERBRAIN™



THE MICRO COMPUTER THAT HAS
THE BEST PRICE/PERFORMANCE
RATIO.

£1695 (64K RAM)

MICROLINE 80

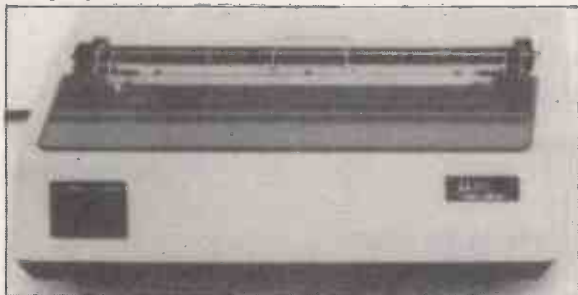

THE EFFICIENT BUSINESS SYSTEM
SUPERBRAIN

+

MICROLINE 80 PRINTER

£1995

INDIVIDUAL PRICE £450.00

DIABLO 630

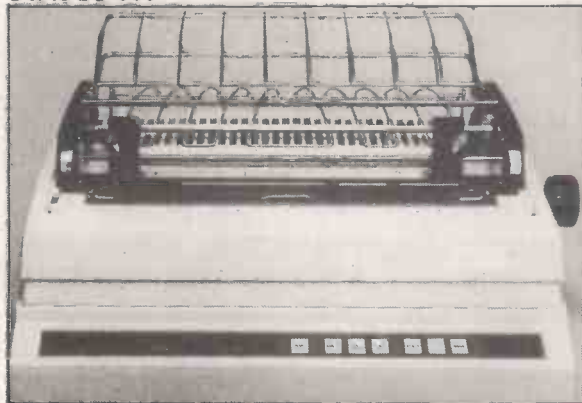

THE COMPLETE WORD PROCESSING
SYSTEM
SUPERBRAIN

+

DIABOLO 630 PRINTER

+

THE PROVEN 'WORD STAR' PACKAGE
MAIL MERGE

£3495

INDIVIDUAL PRICE £1675.00

INCLUSIVE OF INSTALLATION AND TRAINING

SOFTWARE SUPPORT

- * KGB offer a wide range of standard software — FORTRAN, COBOL, BASIC, PASCAL.
- * KGB will customise our software packages to meet your unique requirements — Invoicing £95, Sales Ledger £235, Purchase Ledger £235, Nominal Ledger £235, Payroll £335.
- * KGB will design and implement software to suit your business needs.

KGB Micros Ltd., 88 High Street, Slough, Berkshire.
Tel: Slough 38581/38319

Superbrain is the registered trademark of Intertec Data Systems. Prices exc. VAT.

• Circle No. 330



48K Apple][Europlus

Price **£695** + VAT

Supplied with free TV Modulator and of course Apple 1-year warranty.

Disc drive with controller D.Q.S.33

Price **£383** + VAT

All other Apple parts and software available.

Integrated Circuits Memories

Z80 ACPU	7.95	4116	2.25
Z80 APIO	5.95	2114L	1.95
Z80 ACTC	5.95	2708	3.50
Z80 S10/1	25.00	2716	4.75
6802	8.95		

Please add VAT to all prices.

Please send for price list of CMOS & TTL I.C.'s.

CONTACTROL LTD

Free Delivery

Mail Order Dept.
9 High Street, Lenham
Maidstone, Kent ME17 2QD
Tel. (0622) 858753

• Circle No. 331

BUTEL-COMCO

RP1600 Daisywheel Printer

60cps!

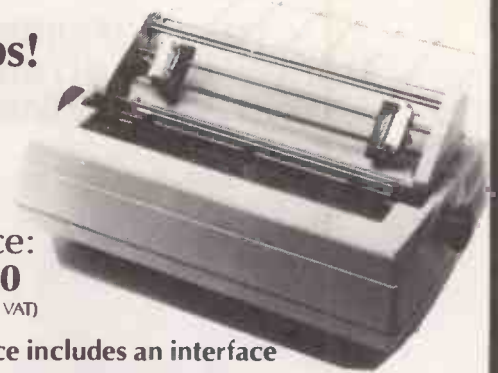

List Price:

£1450

(excluding VAT)

- Price includes an interface
- Interfaces available are Serial V24/IEEE/Centronics/Qume/Hytype
- Trade/OEM discounts available

Write or call for further information

Butel-Comco Limited
Garrick Industrial Centre
Garrick Road Hendon
London England NW9 6AQ
Telephone 01-202 0262
Telex 47523

I am interested in purchasing the RP1600
for connection to

Name

Company

Address

Telephone

Technology for business

PCS/81

• Circle No. 332

V. & T. ELECTRONICS

NASCOM 2
16K RAM BOARD
V & T ASSEMBLER

KIT BUILT

330

385

Z80A 81C BASIC
2K MONITOR EASY +
CHEAP TO EXPAND
* BRITISH *

RAM DOWN!

1 x 4116 < £2
SEE BELOW

FLOPPY DISK CONTROLLER CARD
NASBUS COMPATIBLE HANDLES
8" x 5 1/4" FLOPPIES, SINGLE
OR DOUBLE DENSITY WITH
ONBOARD FACILITIES FOR DMA
AND 32K DYNAMIC RAM
ALL ON ONE 8" x 8" CARD
READY BUILT AND TESTED

DISC CONTROLLER £160
AS ABOVE WITH DMA £190
AS ABOVE WITH 32K RAM £210

V & T ASSEMBLER:

FULLY RELOCATABLE ON TAPE.
STATS MONITOR. **£12.50**
PIO Option **£12** Zeap Eprom **£50**
VART Option **£16** Tape **£30**
CTC Option **£14** Nas Dis **£37.50**
NAS SYS 3 **£40** Naspen **£30**

MEMORY

8 x 4116 200 ns DRAM **£16.00**
TRS80 U/GRADE KIT **£17.00**
1 x 2114 300 ns SRAM **£1.75**
1 x 4118 250 ns SRAM 1K **£8**
1 x 2708 x 1K x 8 EPROM **£3.25**
1 x 2716 5V 2K x 8 EPROM **£5**
1 x 2532 5V 4K x 8 EPROM **£12**

PLEASE ADD V.A.T. AT 15%

82 CHESTER RD LONDON N19 5BZ TEL (01) 263 2643

• Circle No. 333

SYSTEM 4000 EPROM EMULATOR/PROGRAMMERS



P4000 PRODUCTION EPROM PROGRAMMER

This unit provides 'simple, reliable' programming of up to 8 EPROMs. It has been designed for ease of operator use — a single 'program' key starts the blank check — program — verify sequence. Independent blank check and verify controls are provided along with mode, pass/fail indicators for each copy socket and a sounder to signal a correct key command and the end of a programming run. Any of the 2704/2708/2716 (3 rail) and 2508/2758/2516/2716/2532/2732 EPROMs may be selected without hardware or personality card changes. 2 year warranty. Price **£545+VAT**:

VM10 VIDEO MONITOR

This compact, lightweight Video Monitor gives a clean crisp picture on its 10" screen. Suitable for use with the EP4000, SOFTY and other systems. 12 month warranty. Price **£88+VAT, carriage paid**.

MODEL 14 EPROM ERASERS



MODEL UV140 EPROM ERASER

Similar to model UV141 but without timer. Low price at **£61.50+VAT, postage paid**.

EP4000 EPROM EMULATOR/PROGRAMMER

The microprocessor based EP4000 has been designed as a flexible, low cost, high quality unit for emulating and programming all the popular NMOS EPROMs without the need for personality cards, modules or hardware changes. Its software intensive design permits selection of the 2704/2708/2716 triple rail EPROMs and the 2508/2758/2516/2716/2532/2732 single rail EPROMs for both the programming and emulating modes.

The video output (T.V. or monitor) for memory map display in addition to the built-in Hex LED display, for stand alone use, is unique in this type of system. This, with the double function 28 key keypad, powerful editing features, powered down programming socket, buffered tri-state simulator cable and 4k x 8 data RAM gives you the most comprehensive, flexible and compact systems available today.

2 year warranty. Price **£545+VAT**:

MODEL UV141 EPROM ERASER

- 14 EPROM capacity
- Fast erase time
- Built-in 5-50-minute timer
- Safety interlocked to prevent eye and skin damage
- Convenient slide-tray loading of devices
- Available Ex-Stock at **£78+VAT Postage Paid**
- Add **£6** to order total for next day delivery by DATAPOST.

EX-STOCK

PLEASE NOTE OUR NEW ADDRESS/TELEPHONE NUMBER

GP INDUSTRIAL ELECTRONICS LTD,

UNIT 6, BURKE ROAD, TOTNES INDUSTRIAL ESTATE,
TOTNES, DEVON.

TELEPHONE: TOTNES (0803) 863360 (Sales) / 863380 (Technical Service)
DISTRIBUTORS REQUIRED — EXPORT ENQUIRIES WELCOME

SOFTY SYSTEM

EX-STOCK

Low cost card 2704/2708

emulator/programmer features:

- Direct output to T.V.
- High speed cassette interface
- On card EPROM programmer
- Multifunction Keypad
- 1K monitor in 2708
- 1K RAM
- 128 byte scratchpad RAM
- 22 in/out ports
- Access at card edge to all buses
- 1K EPROM EMULATION
- Direct memory access for fast data transfers
- Editing facilities, including — data entry/deletion, block shift, block store, match byte, displacement calculation
- Supplied with Zif socket, simulator cable and comprehensive manual

SOFTY Kit of parts **£100+VAT**

SOFTY Built & tested **£120+VAT**

SOFTY Built power supply **£20+VAT**

P&P IS INCLUDED IN ALL PRICES

Add **£6** to order total for next day delivery by DATAPOST.

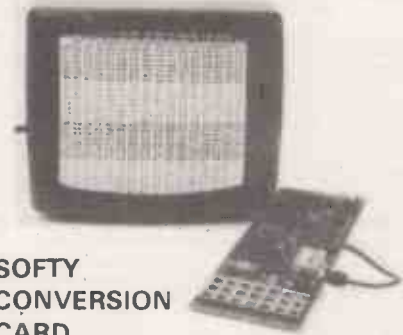

SOFTY CONVERSION CARD

Enables SOFTY to program the single rail EPROMs, 2508/2758/2516/2532. Selection of device type and 1K block are by pcb slide switches. Programming socket is zero insertion force. Easy connection to SOFTY with the DEP Jumper supplied. Built and tested: **£40+VAT, postage paid**.

SOFTY PRINTER

- 40 column electrosensitive printer
- 5 x 7 dot matrix
- print sizes
- Push button hex print-out of SOFTYs RAM, EPROM or inter-cursor contents
- On card PSU
- Selection of bytes per line. Built and tested **£145+VAT, postage paid**.

EX-STOCK EPROMS

	1-9	10-24	25 up
2716 (single rail)	6-95	6-50	5-95
2708	4-00	3-80	3-60
2532	23-40		
2732	21-00		

ADD VAT AT 15% — POSTAGE PAID

WRITE OR TELEPHONE FOR DETAILS ON ANY OF OUR PRODUCTS

• Circle No. 334

**MICRO
BYTE**

We bring you the lowest prices-first!
Compare our prices before you buy elsewhere! All devices are brand new, factory prime, full spec. and fully guaranteed!



Introducing the incredible
Single Board
BIGBOARD
Computer
**64K RAM! Z-80 CPU! FLOPPY
DISK CONTROLLER! 24x80VDU!
PFM 3.3 2K SYSTEM MONITOR!
ALL THIS ON ONE BOARD COMPLETELY
ASSEMBLED AND TESTED AND JUST**

£450! plus £5 p&p and VAT

NEW 6809 S-100 SINGLE BOARD COMPUTER

- Meets IEEE S-100 Standard
- Uses Motorola's Powerful MC6809 CPU!
- 4K, 8K, 16K ROM!
- 2K RAM!
- ACIA, PIA, 8080 Simulated I/O!

 Bareboard only £48! (plus £1 p&p). CPU (6809) £19.00! AD5MON; Monitor (2716) £251 COMPLETE BOARD ASSEMBLED AND TESTED, ONLY £250! (plus £2 p&p).

THE NEW GI COMPUTER SOUND CHIP
The amazing AY-3-8910 is a fantastically powerful sound and music generator, perfect for use with any 8-bit micro processor. Contains 3 tone channels, noise generator 3 channels of amplitude controls 16 bit envelope period control 2 parallel I/O. 3D/A converters plus much more. All in 40 pin DIP Super easy to interface to the S 100 or other Busses.

ONLY £8.50 + VAT, including FREE reprint of BYTE 79 article! Also, add £2.25 for 60 page data manual. "Perhaps the next famous composer will not direct a 150 piece orchestra but rather a trio of microcomputers controlling a bank of AY-3-8910s. BYTE July 79.

BAREBOARD & ROM SETS only £150! (plus £3 p&p) 64K RAM (32 x 4116 200NS) only £64! (plus £1 p&p)

PLUS THESE OPTIONS ON THE BOARD AS WELL

Serial I/O	Full 2 channel using the Z-80 SIO and the SMC 8118 Base Rate Generator. You get FULL RS232C! For synchronous or asynchronous communication, and dteoks can be transmitted or received by a modem in the former. Both channels can be set up for either data communication or data terminals. Supports mode 2 line. PRICE JUST £70 (inc. p&p)
Two Port Parallel I/O	Uses Z-80 P10 to give full 16 bits, fully buffered and bi-directional. User selectable hand-shake polarity. ONLY £23 (inc. p&p)
Real Time Clock	Uses Z-80 CTCard can be configured as a counter on Real Time Clock. ONLY £22 (inc. p&p)
CP/M 2.2	The popular CP/M D.O.S. as modified by Microbyte Systems to run on the BigBoard is just £99 (inc. p&p)
Power Supply	Complete assembled and cased £60 (£2 p&p)

NEW EXCITING, ENTERTAINING SOFTWARE FOR THE APPLE II AND APPLE II+ PLUS!! ASTEROIDS IN SPACE!!!

If you liked Invaders you'll love ASTEROIDS IN SPACE by Bruce Wallace! Your spaceship is travelling in the middle of a shower of asteroids. Blast the asteroids with lasers, but beware - BIG ASTEROIDS FRAGMENT INTO SMALL ASTEROIDS! The apple game paddles allow you to rotate your spaceship, fire its laser gun, and give it thrust to propel it through endless space. From time to time, too, you'll encounter an alien spaceship whose mission is to DESTROY YOU, so you'd better destroy it first! High resolution graphics and sound effects add to the arcade-like excitement this program generates. RUNS ON ANY APPLE II WITH AT LEAST 32K AND ONE DISK DRIVE!
ON DISKETTE ONLY £14.95

Three years' development went into BigBoard, designed from scratch to run the latest version of CP/M, so just imagine what software you could run WITH NO MODS! Add a couple of B' Disk Drives, a Video Monitor and Keyboard, an enclosure and the Power Supply option - and you've got a complete business system for about ONE THIRD the COST!
That's what BigBoard can offer - flexibility, power, and incredible economy! Send for your BigBoard TODAY!

Size 8 1/2 x 13 3/4 inches.
Requires +5V @ 3 Amps
+/- 12V @ 0.5 Amps.

Floppy disk/Siemens FDD 100-8 £315 (PLUS VAT) Drives

NEW! SPECIAL OFFER! 4K CMOS RAM (1K x 4) 450 NS ONLY £5.50.
The TC 5514P from Toshiba, CMOS equivalent of the 2114!

Lower Power Dissipation
 .10uW/BIT (TYP) at 3.0V (STANDBY)
 .10uW/BIT (TYP) at 5.0V (OPERATING)
 * Data Retention Voltage 2V to 5.5V
 * Single 5V Power Supply
 * 18 PIN Plastic Package
 * Full Static Operation
 * Three State Output
 * Input/Output TTL Compatible
 * Fast Access Time 450NS
 Toshiba's TC5514P (Industry type 6514) is a full static read write memory organised as 1024 words by 4 bits using CMOS technology. Ultra low power dissipation means it can be used as battery-operated portable memory system and also as a non-volatile memory with battery back-up. Operates from a single 5V power supply with static operation, hence no refresh periods and a much simplified power supply circuit design. Three state outputs simplify memory expansion for minimum data retention voltage is 2V, the battery back-up system needs only simple circuit. Toshiba's original CMOS technology also means wide operating and noise margins. The TC 5514P is moulded in a dual-in-line 18 pin plastic package 0.3 inch in width.

Microchips at micro prices!

INTERFACE LINEAR	SUPPORT DEVICES	CPU'S	EPROM's	BIPOLAR PROMS	FLOPPY DISK CONTROLLERS
MC1489 80p	6520 325p	6502 625p	2708 450 NS 375p	93448 518 x 840 NS p.o.a.	FD1771 B-01 S/D Inverted Bus £29.95
DM8123 125p	6522 825p	6504 705p	2716 5V 450 NS 495p	93451 1k x 440 NS p.o.a.	FD1791 B-01 D/D Inverted Bus £39.95
75150 125p	6551 825p	6505 705p	2532 32K 450 NS £18.95	93451 1k x 845 NS p.o.a.	FD1792 B-01 S/D Inverted Bus £34.95
75154 125p	6551 825p	6800 605p	2732 Intel-type 450 NS £18.95	93511 2k x 850 NS p.o.a.	FD1793 B-01 D/D True Bus £54.95
75182 195p	6810 350p	6802 905p	2564 64K (8K x 8) 450 NS 28-pin NEW! £99		FD1794 B-01 S/D True Bus £34.95
75322 250p	6820 425p	6809 £19			FD1795 B D/D Inverted Bus, Side Select £59.95
75324 325p	6850 425p	8080A 525p			FD1797 B D/D True Bus, Side Select £59.95
75325 325p	6852 425p	8085A £10.95			
75361 350p	8212 395p				
75365 205p	8214 450p				
75451 50p	8216 395p				
75491/2 75p	8224 395p				
8T28 175p	8228 395p				
8T28 175p	8251 495p				
8T85 175p	8253 £11.25				
8T97 175p	8255 495p				
	8257 £10.50				
	8259 £13.25				
KEYBOARD ENCODER	MC144 12VL 797p				
AY-5-2376 795p	Z80 P10 895p				
	Z80 CTC 595p				
	Z80A P10 695p				
	Z80A CTC 695p				
	Z80 DMA £19.95				
	Z80A DMA £24.95				
	Z80 SIO10 £29.95				
	Z80 S100 £34.95				
	Z80 S101 £29.95				
	Z80A S101 £34.95				
	Z80 S102 £29.95				
	Z80A S102 £34.95				
CHARACTER GENERATOR					
RO-3-2513UC 450p					
DEVELOPMENT MODULE					
Z8000 DM £1099					
DISPLAYS					
FDN500 80p					
FDN510 80p					
FDN567 125p					
DL704 85p					
DL707 85p					
MV57164 225p					
	UARTS				
	AY-5-1013A 325p				
	AY-3-1015D 398p				
	IM6402IPL 325p				

NEW, LOW, LOW PRICES ON MEMORIES!!!
Compare our prices before you buy elsewhere! All devices are brand new, factory prime, full spec. and fully guaranteed. All prices exclude p&p and VAT. Please refer to Ordering Information before ordering. DON'T DELAY - BUY TODAY - SUCH LOW PRICES DON'T LAST FOR EVER!!!

STATIC RAMS	CMOS RAMS	EPROMS
2114L 450 NS 195p	5101 1K (256 x 4) 450 NS 350p	2708 450 NS 350p
2114L 300 NS 225p	450 NS 325p	2716 Single 5V 450 NS 475p
2114L 200 NS 250p	4315 4K (4K x 1) 450 NS 995p	2532 Single 5V 450 NS £14.95
4118 250 NS 8K 895p	TC5514P 4K (1K x 4) 495p	2732 Intel-type 450 NS £14.95
NEW!! HM6116 16K (2K x 8) 895p	450 NS 450p	2564 64K (8K x 8) 450 NS 28-pin £99
150 NS 24-pin NEW!! £19.95	HM6116 16K (2K x 8) 450 NS 495p	£95
DYNAMIC RAMS		£90
4116 200 NS Ceramic 195p		
4116 150 NS 375p		
HM4864 64K (65K x 1) 200 NS Single + 5V supply 16-pin-NEW!! £29.95		

NEW SUPER MUSIC MACHINE KIT!
AT LAST - an affordable kit that can be PROGRAMMED TO PLAY ANY SONG OR GROUP OF SONGS! Instead of a nightmare of numerous ICs and special expensive Bipolar ROMs the SUPER MUSIC MACHINE uses a SPECIAL MASK PROGRAMMED COMPUTER CHIP one CMOS gate and the most popular erasable EPROM, the 2708/2716 series. BASIC KIT includes drilled, plated and screened PC board and ALL components except the EPROM and 12V transformer. The basic kit will play short renditions of 25 tunes through its 7 WATT AMPLIFIER SECTION. Add an optional ROM and any tune programmed will be played. If you have the equipment to program 2708 EPROMs, we supply full information on programming your own musical FEATURES:
 * Basic kit contains 25 short tunes in the main ICL.
 * Will address external ROM for up to 1,000 MORE NOTES per ROM (ROM is not included).
 * Operates on 12V AC or 12V DC at 500mA. (Using unit on 12V DC and with optional ROM requires 9V bias battery, not included).
 * 7 watts of audio power will drive 8 or 16 ohm speakers or horn speakers (not included).
 * DIP switches not included.
 * "NEXT TUNE" provision steps sequentially through all tunes.
 * Tune address can be wire jumper selected or board is designed to take DIP switches.
 * PITCH VOLUME and TEMPO are all adjustable.
 * SPECIAL "CHIME" SEQUENCES can be activated regardless of tune address to provide for multiple doorbell applications.
 * All tunes consist of electronic musical notes played one at a time. There are no chords or harmony sound to the music.
 * STEP-BY-STEP ASSEMBLY INSTRUCTIONS provided.
 * Large number of PREPROGRAMMED ROMS with popular and classical tunes readily available. Send SAE for list and prices.
 * ONLY £16.75 for basic kit (plus p&p 60p).

Ordering Information. Unless otherwise stated, for orders under £50 add 50p p&p. Add 18% VAT to total (no VAT on books). All devices are brand new, factory prime and full spec. and subject to prior sale and availability. Prices subject to change without notice. Minimum telephone order using ACCESS is £10. If ordering by post with ACCESS, include name, address and card no.

Microbyte, Dept. PC8 Unit 9/10, 1st Floor, E Block, 38 Mount Pleasant, London WC1X 0AP. Telephone: 01-278 7369 Telex: 895 3084

Computer Weekly brings you

COMPEC NORTH '81

Belle Vue,
Manchester
June 23-25, 1981

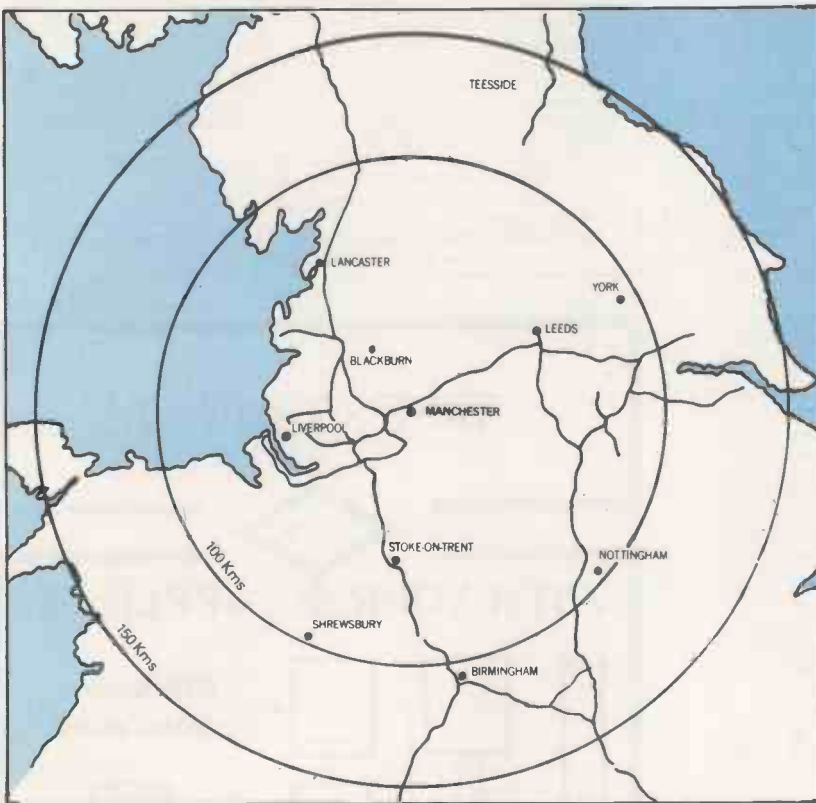

— for the first time, an extension of the UK's largest computer show, COMPEC, comes to the heart of industrial Britain.

Computers, peripherals, terminals, software, mini- and micro-computers and services — the most comprehensive computer exhibition ever staged in the North of England.

Admission is by business registration and £2.00 at the door. **Save time and money by planning your visit now — send in advance for half-price tickets at £1.00 each and mark the dates in your diary —**

Tuesday, June 23: 10.00-18.00
Wednesday, June 24: 10.00-18.00
Thursday, June 25: 10.00-16.30

COMPEC NORTH '81

Sponsored by Computer Weekly,
Data Processing, Systems International
& Practical Computing,
Organised by IPC Exhibitions Ltd.

Please send.....tickets, I enclose remittance of £.....

Compec North '81 Tickets, IPC Exhibitions Ltd
Surrey House, 1 Throwley Way, Sutton, Surrey SM1 4QQ
(cheques payable to IPC Business Press Ltd.)

Name _____

Company _____

Address _____

PCS/81

(Applications not accepted after June 8. No school parties, no children under 16)

• Circle No. 336

Hellfire Warrior

16k LII cassette £15.95

32k TRSDOS Disk £17.95

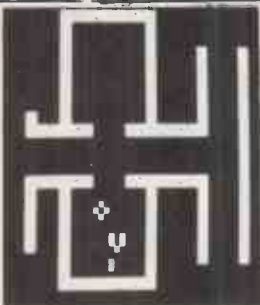

The basic DUNJONQUEST system presented in The Temple of Apsai has been expanded with more command options, more potions, (there are now 13!), more magical items (including the long-awaited, often requested magic armour), and more special effects. The result is Hellfire Warrior.

In addition to an innkeeper, Hellfire Warrior has an armorer, an apothecary and a magic shop. There are four new levels of sixty rooms each. In general, the treasures are richer, the magic more potent, the monsters more dangerous and the levels more challenging.

Level 5: "The Lower Reaches of Apsai" — The first level of Hellfire Warrior is a sequel to The Temple of Apsai; it is populated by the same sort of giant insects and other nasties that inhabit the upper levels. There are magical rooms that let an adventurer in but not out, various tricky traps and other surprises, but it is probably a bit less hazardous than the 4th level of the Temple.

A Puzzle to Solve

Level 6: "The Labyrinth" — This is a classical maze inhabited by minotaurs and the like. It is as much a puzzle to solve as a dunjon to explore, because the only exit is hidden somewhere in the labyrinth, and hordes of man-eating monsters can thwart the most logical search. The graphic presentation is marvelously realistic: the adventurer's vision is limited to his immediate surroundings; paths go every which way and there are no room numbers to help him find the way.

Tough To Survive

Level 7: "The Vault of the Dead" — This is a more conventional level, with rooms, doors, secret passages and so on. Its uniqueness lies in its inhabitants, most of whom rank among the so-called undead: skeletons, ghouls, mummies, spectres — even invisible ghosts. What makes many of them so terrifying is that they can reduce the adventurer's characteristics permanently; even if he survives, he may be no more than a pale shadow of the hero he used to be.

Quest Leads To Hell

Level 8: "The Plains of Hell" — The culmination of the adventure lies in an Underworld haunted by lost souls and shades of the dead, guarded by dragons and fiery hounds and riddled with bottomless pits and blasts of hellfire. The entering adventurer soon faces a choice of three bridges, each guarded by a different fearsome beast. On the far side is a vast plain cloaked in darkness — a maze devoid of walls or room numbers. Finding a way back is not too difficult (not as difficult as *getting* back), but the quest leads onward, over a hidden bridge on a perilous trail to a slab of black stone on which, in enchanted sleep, lies the warrior maid Brynhild, circled by a wall of everlasting fire. To bring her back to sun and air and break the spell that binds her, the adventurer must overcome the legions of the lost, slay the nine-headed pyrohydra and the great bat-winged demon that rules the Underworld, cross the bridges of flame, endure a cold that numbs the soul and face Death itself. And live.

Morloc's Tower (R.T.G.) £10.95 Rescue at Rigel £10.95
 Datstones of Ryn (R.T.G.) £10.95 Starfleet Orion £12.95
 Temple of Apsai (R.T.G.) £14.95 Invasion Orion £13.95

All prices include p & p and V.A.T.

ALGRAY

ALGRAY House, 33 Bradbury Street, Barnsley.
 South Yorkshire Tel: Barnsley (0226) 83199



• Circle No. 337

3D COMPUTERS

SYSTEMS

SUPERBRAIN SHARP MZ-80K ZUNDRIES
 SHARP PC-3201 SERVICE SUPPORT

SOFTWARE

3D COMPUTERS are suppliers of COMPLETE SYSTEMS based on SHARP and Intertec SUPERBRAIN microcomputers and are now appointed distributors for MICROEASE software products for SUPERBRAIN and SHARP PC-3201.

EASYFILLER™

Complete information storage and retrieval system. User defined file formats, report formats and record selection criteria. Records can be accessed by key or searched for by selection by multiple conditions on multiple fields. Reports are output on printer or screen with totalling and breakpoints. Files of extracted records may be produced for input to Wordstar/Mailmerge.

Applications: Library, Cataloguing, Indexing Systems; Market research and analysis; Selective mailshots; Personnel records; Employment and Estate Agency; Laboratory records etc. **£275.00**

EASYPLANNER™

Comprehensive resource scheduler. Jobs partitioned into discrete activities or processes are allocated over resources such as equipment and a workforce with variable skills levels. Schedules produced to obtain optimum utilisation of resources. Immediate rescheduling possible if equipment fails or workforce reduced. Capacity and resource planning.

Applications: Shop floor control; Service management; Project planning; Timetables; Staff allocation etc. **£400.00**

EASYTIMER™

Time recording and monitoring system. Assignments or jobs can be broken down into sub-jobs and activities. Charge rates may be set by activity and employee. Budgets may be allocated. Selective reporting on time spent and budget status produced on demand. Totals by Account, Job and Employee. Overspends on budget highlighted.

Applications: Engineering, Advertising, Management Consultancies; Project management; Accountants; Solicitors; Architects etc. **£400.00**

Callers welcome at our COMPUTER SHOP on the A3, Kingston By-Pass. Open Saturdays. Dealer enquiries welcome

230 TOLWORTH RISE SOUTH, TOLWORTH, SURBITON, SURREY KT5 9NB
 Tel: 01-337 4317 Telex: 945966 AIRCLA G

• Circle No. 338

TAKE CONTROL



WITH YOUR APPLE II

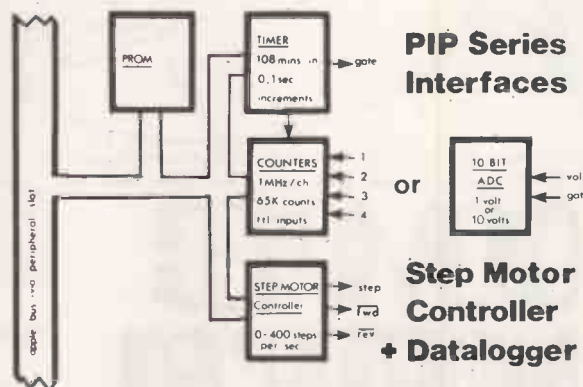

Motor drives available for both low and high power applications.

Cost Effective Control from

J S SYSTEMS Ltd 18 PORTMAN Rd READING RG5 9PE

• Circle No. 339

COMPUTECH for



COMPUTECH for

ITT

Well proven software for business applications on the
ITT 2020 and Apple microcomputers.

Prices excluding V.A.T. for cash with order, F.O.B. London NW3

PAYROLL	(300+ Employees, 100 Departments, hourly, weekly, monthly. Very powerful but easy to use).	£375
SALES LEDGER	(500+ Accounts, 100 Departments).	£295
PURCHASES LEDGER	(500+ Accounts, 100 Departments).	£295
GENERAL (OR NOMINAL) LEDGER	(1000 Accounts, 100 Analyses, multi-purpose package). Job costing etc.	£295
UTILITIES DISK 1	(Diskette patch, slot to slot copy, zap etc).	£20
APPLEWRITER	(Word Processing, see below for U/L case).	£42
VISICALC	(Financial Modelling, Costing, Analysis).	£95
CAI	(Converts Apple pictures for ITT display).	£10

Over 500 packages in use, fully supported by us.

AND NOW HARDWARE!

LOWER & UPPER CASE CHARACTER GENERATOR £50
Replaces character generator to display upper and lower case characters on screen, includes patches to work with Applewriter, supplies the missing link! Specify Apple or ITT.

COMPUTECH DIPLOMAT H/S SERIAL INTERFACE £80
This card has been designed and built to the same professional standards that have resulted in the success of our software. The DIPLOMAT observes the proper "handshaking" protocol so that you can drive fast printers and send and receive data from other peripherals at high speeds without loss of data. Switch (& software) selectable baud rates to 19200 and many other options. Plug compatible with 'terminal' or 'modem' wired peripherals. Guaranteed.

MICROLINE M80 PRINTER £425
This neat, reliable machine prints at 10 characters per inch, 80 characters on an 8 inch line, or 40 expanded characters, or 132 very readable characters, upper and lower case and graphics, 9 x 7 dot matrix, 6 or 8 lines per inch. Parallel interface is standard, serial optional. Both friction and sprocket feed are standard, tractor optional. We can also supply the parallel interface card for Apple System computers for £80 and a driver to enable both text and graphics to be used. Optional custom colour matching for Apple or ITT. Optional character sets. *Trade supplied at very generous discounts for modest quantities.*

THE FABULOUS MICROMUX 8000 from £800
This is a brand new product, an asynchronous serial multiplexor with up to 16 ports, any one of which may communicate with any other independently, like a 'telephone exchange' for data! Built in test function. Firmware may be customised for special applications. Available in multiples of 4 ports up to 16.

COMPUTECH SYSTEMS

168, Finchley Road, London NW3 6HP. Tel: 01-794 0202

AGENTS THROUGHOUT THE UK AND OVERSEAS

• Circle No. 340

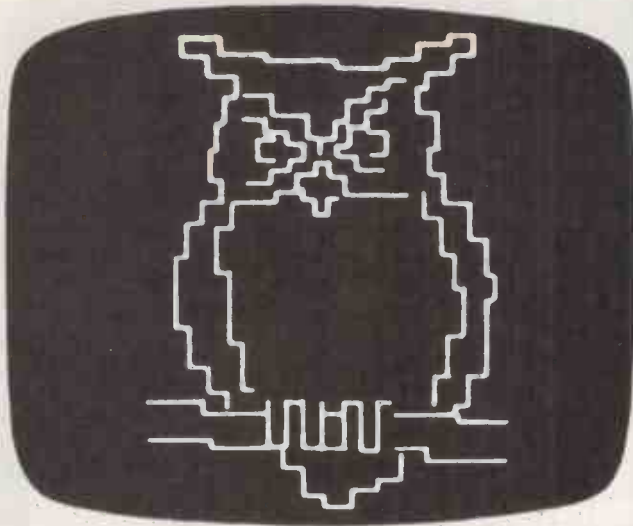

**You lucky Apple II owners—
by adding **Appletel** you
can have the only
PO approved
computer connection**

With Appletel you can link your present Apple II computer direct to Prestel for just £595 plus VAT - which is a major cost saving for a start. Add in these other major advantages and you'll really appreciate what the complete Owl Computer package can do for you!

- ★ Save on telephone bills by storing pages from Prestel on a floppy disc - screen them up on Apple II when you're ready.
- ★ Programme the unit to automatically call up a sequence of pages, and store them for later examination.
- ★ Write your own BASIC programs to process Prestel data as well as send commands to Prestel.
- ★ The full keyboard means you can use Prestel to maximum advantage for sending messages.
- ★ Appletel is now available in colour

For full details on what Appletel can do for you, and the name of your nearest dealer, please phone or write.

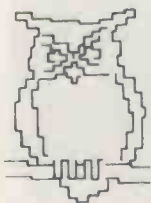

Owl Computers

18 Hadham Road, Bishop's Stortford
Herts CM23 2QR
Tel: Bishop's Stortford (0279) 52682

• Circle No. 341

PRICE BEATERS!

READY TO USE SYSTEMS

- Business System £2295
- Accountants System £2295
- Finance House System £2500
- Word Processing System £3000
- Hotel System £2500
- Payroll System £2295 + VAT

Systems include:

SUPERBRAIN, PRINTER, INTEGRATED SOFTWARE, FULL DOCUMENTATION. + MULTI-USER SYSTEMS AVAILABLE.

WE ARE THE EXPERTS!

Contact: 0924 82636

ANPAC SYSTEMS

MARTIN HOUSE
MARTIN STREET
BRIGHOUSE

92 CANAL LANE
LOFTHOUSE GATE
WAKEFIELD

• Circle No. 342

Microcomputers

moran

MZ80 48K

OUR PRICE **£460.00**

No gimmicks, No giveaways. Just good value for money

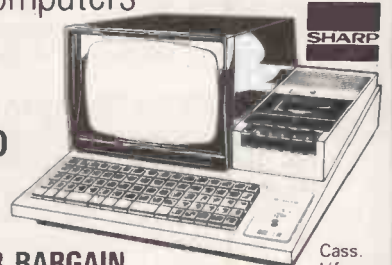

THIS MONTH'S STAR BARGAIN
Sharp PC-1211 Pocket Computer
£82.00

Cass.
1/face
£15.95

TRS-80

- 0 Expansion Interface Units **£173.87**
- 16K Ram Upgrades (same day service) **£30.00**
- Disk, Drives, Singles, Twins 40-80 track from **£236.00**
- For TRS-80 and Video Genie
- Stringy Floppies TRS-80 **£169.** V/Genie **£179**
- Video Genie 16K Level II **£299.00**

CREDIT FACILITIES AVAILABLE ON ALL PURCHASES OVER £150.00 (written quotations on request)

We fully support the products we sell.

TOP QUALITY 5¼" Floppy Disks £156 each.
Cassettes, Drivers, Tapes, Books, Paper, Cables, Software for Entertainment, Business and Educational purposes.

C. W. O. Please add VAT and carriage. Personal callers welcome

micro-chip SHOPS
91 FRIARGATE, PRESTON, LANCs
197 WATERLOO ST., BLACKPOOL
190 LORD ST., FLEETWOOD

L. D. MORGAN & CO. LTD
Computer Systems Design
Head Office:
Tel. Fleetwood 79511/79480

• Circle No. 343

TTLs by TEXAS		74LS161		75p		4002		20p		PERIPHERALS		MEMORIES		INTERFACE ICs		MISCELLANEOUS	
7400	11p	74173	120p	74LS161	75p	4002	20p	4560	200p	3242	800p	RAMS	AD5611	1400p	6MHz UHF Mod.	350p	
74500	60p	74174	90p	74LS162	140p	4006	95p	4569	250p	3245	450p	2101-4L	AD7524	600p	8MHz UHF Mod.	450p	
7401	12p	74175	85p	74LS163	100p	4007	90p	4572	80p	6522	600p	2102-2L	DAC1408-8	200p	16 Key Pad	450p	
7402	12p	74176	90p	74LS164	90p	4008	80p	4583	110p	6522	800p	2111-4L	DM8131	375p	5100 Busboard	1500p	
7403	14p	74177	90p	74LS165	140p	4009	40p	4584	60p	6532	375p	2112A	DP8304	450p	DIN41612 Plug	450p	
7404	14p	74178	110p	74LS166	180p	4010	50p	4585	150p	6820	300p	2114-2L	DS8835	250p	DIN41612 Socket	450p	
7405	18p	74179	90p	74LS167	110p	4011	20p	4585	150p	6821	300p	2114-3L	DS8836	150p	43 way Edge Con.	250p	
7406	36p	74180	90p	74LS173	110p	4012	25p	4724	250p	6850	300p	2114-4L	DS8838	225p	31 way Plug 0.1"	120p	
7407	36p	74181	160p	74LS174	100p	4013	25p	40097	90p	6852	370p	4027-3	MC1488	75p	31 way SKI 0.1"	120p	
7408	17p	74182	90p	74LS175	100p	4014	84p	14411	700p	8155	1100p	4044-4	MC1489	75p	Logic Probe LP1	£31	
7409	19p	74183	150p	74LS181	320p	4015	84p	14412	900p	8205	320p	4116-2	MC3446	325p	Logic Probe LP2	£18	
7410	15p	74184	500p	74LS190	100p	4016	45p	14433	1100p	8212	175p	4118-4	MC3480	800p	Logic Probe LP3	£49	
7411	24p	74185	500p	74LS191	100p	4017	70p	14599	290p	8216	200p	5101	MC3487	300p	Zero Insertion Force Socket	24 pin £7	
7412	20p	74186	90p	74LS192	100p	4018	89p			8224	400p	6810	MM58174	1200p	DIL Switches		
7413	30p	74187	90p	74LS193	100p	4019	45p			8226	400p	6116	81LS97	120p	4 way SPST	90p	
7414	40p	74188	325p	74LS194	100p	4020	100p			8228	400p	6514	81LS97	120p	6 way SPST	105p	
7415	20p	74189	90p	74LS195	140p	4021	100p			8251	475p	4164	81LS98	140p	8 way SPST	120p	
7416	27p	74190	90p	74LS196	120p	4022	100p			8253	450p		9601	110p			
7417	27p	74191	90p	74LS197	90p	4023	27p			8257	450p		9602	220p			
7420	17p	74192	90p	74LS198	100p	4024	50p			8259	900p		TMS9914	£25			
7421	40p	74193	90p	74LS199	90p	4025	20p			8259	950p						
7422	22p	74194	90p	74LS200	100p	4026	130p			8279	950p						
7423	34p	74195	95p	74LS201	120p	4027	50p			Z80-CTC	700p						
7425	30p	74196	95p	74LS221	120p	4028	84p			Z80A-CTC	700p						
7426	40p	74197	80p	74LS240	150p	4029	100p			Z80-P10	600p						
7427	40p	74198	150p	74LS241	150p	4030	50p			Z80DART	£12						
7428	36p	74199	150p	74LS242	170p	4031	200p			Z80ADART	£15						
7429	30p	74200	150p	74LS243	170p	4032	200p			Z80ADMA	£12						
7430	30p	74201	160p	74LS244	150p	4033	295p			Z80A-P10	700p						
7431	30p	74202	160p	74LS245	150p	4034	295p			Z80-S10-1	2400p						
7432	30p	74203	160p	74LS247	140p	4035	295p										
7433	40p	74204	160p	74LS248	140p	4036	295p										
7434	40p	74205	160p	74LS249	140p	4037	295p										
7435	35p	74206	150p	74LS250	140p	4038	100p										
7436	35p	74207	150p	74LS251	140p	4039	100p										
7437	35p	74208	150p	74LS252	90p	4040	100p										
7438	35p	74209	150p	74LS253	90p	4041	80p										
7439	35p	74210	150p	74LS254	90p	4042	80p										
7440	17p	74211	200p	74LS255	90p	4043	80p										
7441	70p	74212	200p	74LS256	160p	4044	90p										
7442A	60p	74213	200p	74LS257	160p	4045	90p										
7443	112p	74214	200p	74LS258	160p	4046	110p										
7444	112p	74215	200p	74LS259	375p	4047	110p										
7445	100p	74216	200p	74LS260	375p	4048	110p										
7446A	93p	74217	200p	74LS323	400p	4049	55p										
7447A	75p	74218	100p	74LS324	400p	4050	45p										
7448	80p	74219	100p	74LS325	400p	4051	80p										
7450	17p	74220	100p	74LS326	400p	4052	80p										
7451	17p	74221	100p	74LS327	400p	4053	80p										
7453	17p	74222	100p	74LS328	400p	4054	80p										
7454	17p	74223	100p	74LS329	400p	4055	125p										
7460	17p	74224	100p	74LS330	400p	4056	135p										
7470	36p	74225	100p	74LS331	400p	4057	135p										
7472	30p	74226	100p	74LS332	400p	4058	600p										
7473	34p	74227	100p	74LS333	400p	4059	600p										
7474	30p	74228	100p	74LS334	400p	4060	115p										
7475	38p	74229	100p	74LS335	400p	4061	120p										
7476	32p	74230	100p	74LS336	400p	4062	50p										
7480	50p	74231	100p	74LS337	400p	4063	450p										
7481	100p	74232	100p	74LS338	400p	4064	27p										
7482	84p	74233	100p	74LS339	400p	4065	20p										
7483a	90p	74234	100p	74LS340	400p	4066	30p										
7484	100p	74235	100p	74LS341	400p	4067	30p										
7485	110p	74236	100p	74LS342	400p	4068	30p										
7486	34p	74237	100p	74LS343	400p	4069	30p										
7489	210p	74238	100p	74LS344	400p	4070	30p										
7490A	30p	74239	100p	74LS345	400p	4071	25p										
7491	80p	74240	100p	74LS346	400p	4072	25p										
7492A	46p	74241	100p	74LS347	400p	4073	25p										
7493A	36p	74242	100p	74LS348	400p	4074	25p										
7494	84p	74243	100p	74LS349	400p	4075	25p										
7495A	70p	74244	100p	74LS350	400p	4076	107p										
7496	65p	74245	100p	74LS351	400p	4077	107p										
7497	180p	74246	100p	74LS352	400p	4078	27p										
74100	130p	74247	100p	74LS353	400p	4079	27p										
74107	34p	74248	100p	74LS354	400p	4080	27p										
74109	55p	74249	100p	74LS355	400p	4081	27p										
74116	200p	74250	100p	74LS356	400p	4082	27p										
74118	130p	74251	100p	74LS357	400p	4083	27p										
74119	210p	74252	100p	74LS358	400p	4084	72p										
74120	110p	74253	100p	74LS359	400p	4085	150p										
74121	34p	74254	100p	74LS360	400p	4086	150p										
74122	48p	74255	100p	74LS361	400p	4087	70p										
74123	60p	74256	100p	74LS362	400p	4088	70p										
74125	75p	74257	100p	74LS363	400p	4089	250p										
74126	60p	74258	100p	74LS364	400p	4090	95p										
74128	75p	74259	100p	74LS365	400p	4091	95p										
74132	75p	74260	100p	74LS366	400p	4092	340p										
74136	75p	74261	100p	74LS367	400p	4093	120p										
74137	50p	74262	100p	74LS368	400p	4094	120p										
74141	50p	74263	100p	74LS369	400p	4095	95p										
74142	200p	74264	100p	74LS370	400p	4096	95p										
74145	90p	74265	100p	74LS371	400p	4097	340p										
74147	190p	74266	100p	74LS372	400p	4098	120p</										

**THE PRINTER SCOOP OF THE YEAR - SAVE OVER £1400
THE LOGABAX Z80 MICROPROCESSOR CONTROLLED
LX180L MATRIX PRINTER**

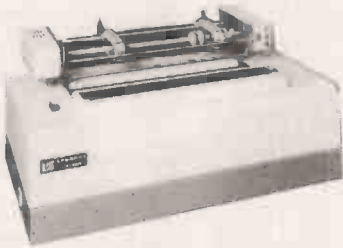

A massive bulk purchase enables us to offer you this superb professional printer at a fraction of its recent cost of over £2000. Utilising the very latest in micro-processor technology, it features a host of facilities with all electronics on one plug in P.C.B. Just study the specification and you will instantly realise it meets all the requirements of the most exacting professional or hobbyist user.

STANDARD FUNCTIONS * Full ASCII character set * Standard ink ribbon * RS232/V24 serial interface — 7 xtal controlled baud rates up to 9600 * 194 characters per line * Parallel interface * Handshakes on serial and parallel ports * 4 Type fonts, italic script, double width, italic large, standard * Internal buffer * Internal self test * 170 CPS * Variable paper tractor up to 17.5" wide * Solid steel construction * All software in 2708 eeproms easily reconfigured for custom fonts etc.

All this and more, not refurbished but **BRAND NEW** At Only

£525 + carriage and ins. **£18.00** + VAT

OPTIONAL EXTRAS * Lower case £25.00 * 16K buffer £30.00 * Second tractor for simultaneous dual forms £85.00 * Logabax maintenance P.O.A. All prices subject to VAT — AVAILABLE ONLY FROM:

DISPLAY ELECTRONICS & COMPUTER APPRECIATION
64-66 Melfort Rd, Thornton Heath
Croydon, Surrey. 01-689 7702/6800
Telex 27924 Ref Fisher
86 High Street, Bletchingley
Surrey
0883 843221

• Circle No. 345



Diskwise Ltd

25 Fore Street, Callington
Cornwall, PL17 7AD.
Tel: 05793 3780

Quality Business Software for the Apple Computer

HOTEL PLAN — a hotel management program — including reservations & billing.

The ultimate in Apple business Software HOTELPLAN caters for large & small hotels alike. Capacity 100 Rooms with 2 disc drives, 200 rooms with 3 disc drives etc. Multi user with hard discs for larger hotels. Equally suitable for small hotels. Price £695.

Reservation chart displays room status for any period
• Produces reservation & booking letters. • Arrivals & departures list • 26 credit agencies • guest billing • provision for extras etc • print out of all financial reports • Lots more...

UNIVERSAL RENTAL MANAGEMENT

Designed originally for TV rental management this sophisticated program will work equally well with long or medium term rental of most equipment. Price £495.

Stores & prints out all customer & equipment details
• Various payment periods
• Manual or Auto print of overdue a/c & renewal letters
• Customer payment history
• Handles maintenance contracts • Financial Reports etc.

Send for details. Dealer & overseas enquiries welcome.

We are dealers for:

Apple II, Video Genie, Transam Tuscan, & a full range of printers etc.

• Circle No. 346

IT'S ACTION! IT'S REAL-TIME! IT'S

FROGS!



A brand new game from a brand new writer, Chris Smyth, bringing action and excitement never obtained before.

You have just 250 seconds to shoot down the Frogs, as they leap around the screens in a most haphazard way, or you are finished!

You have the ability to aim, controlling the angle of fire with two keys. The computer keeps a score of the number of shots, the number of hits and of course the time, which ticks relentlessly away. At the end up comes your score — which, damn the thing, makes it addictive!

AND IT'S THREE IN ONE

Not only do you get this fast action game, but two logic problems as well, which as Frogmaster you have to solve in as few moves as possible. In one you leap the two types of Frogs into order and in the other you leap the Frogs in pairs to separate the two types. We guarantee that Frogs will take the computer world by storm for the game itself is a winner, but with the two extra logic problems it really is exceptional value for money.

For the Tandy TRS-80 and the Video Genie and available only from Kansas **£9.50**

Kansas

Kansas City Systems, Unit 3, Sutton Springs Wood, Chesterfield, S44 5XF. Tel. 0246 850357

• Circle No. 347

All prices are Vat paid and post free. Return first class post service. Barclaycard Visa orders sent same day if phoned in by 3pm. Answering machine ordering service after 6pm and Sundays to allow use of cheap rate. Catalogue available upon request.

FACTORY FRESH BRAND NAME

5 1/4" MINI DISKS

FREE PLASTIC LIBRARY BOX
WITH EVERY TEN-PACK
ORDERED

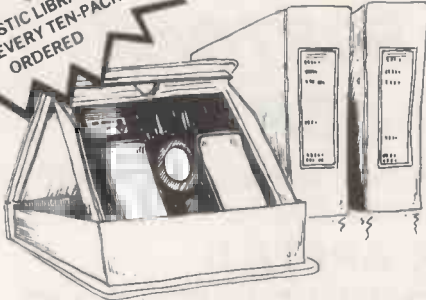

DISCOUNT PRICES PER TEN-PACK

All Disks are Factory Fresh, and incorporate latest manufacturers mods.

MEMOREX :

The Ultimate in Memory Excellence



MEM 1 S/Sided, Soft* Sector, S/Density
MEM 1D S/Sided, Soft* Sector, D/Density
MEM 2D D/Sided, Soft* Sector, D/Density

	NET	VAT	TOTAL
MEM 1 S/Sided, Soft* Sector, S/Density	£16-48	£2-47	£18-95
MEM 1D S/Sided, Soft* Sector, D/Density	£20-39	£3-06	£23-45
MEM 2D D/Sided, Soft* Sector, D/Density	£23-44	£3-52	£26-96

Verbatim :

New Datalife Brand, with hub ring reinforcement



MD525 S/Sided, Soft* Sector, 35/40-Track
MD550 D/Sided, Soft* Sector, 35/40-Track
MD577 S/Sided, Soft* Sector, 77-Track

MD525 S/Sided, Soft* Sector, 35/40-Track	£17-35	£2-60	£19-95
MD550 D/Sided, Soft* Sector, 35/40-Track	£26-04	£3-91	£29-95
MD577 S/Sided, Soft* Sector, 77-Track	£27-50	£4-13	£31-63

Verbatim

BASF :

Typical West German Precision



BASF 1 S/Sided, Soft* Sector, S/Density
BASF 1D S/Sided, Soft* Sector, D/Density
BASF 2D D/Sided, Soft* Sector, D/Density

BASF 1 S/Sided, Soft* Sector, S/Density	£19-96	£2-99	£22-95
BASF 1D S/Sided, Soft* Sector, D/Density	£22-50	£3-38	£25-88
BASF 2D D/Sided, Soft* Sector, D/Density	£25-61	£3-84	£29-45

* All the above, are available in 10 or 16 Hard Sector at the same price, so please specify clearly when ordering, whether soft, 10 or 16 hard sector, and if in doubt, telephone us or name your computer on your order.

EUROPHONIC

Disk Drive Head Cleaning Kit

Disk Directories

Disk Directories

DiskWriter 'writes with minimum pressure'

DiskWriter

Plastic Library Boxes

SuperLuxe Disk Library 'holds twenty disks'

You may damage your disks, if you do not use a DiskWriter or equivalent, when writing on your disk labels.

If Order Form has been cut, send your cheque, payable to Cash with order only please.

EUROPHONIC

FREEPOST, Liphook, Hants, GU3 7BR. Tel: 0428 722563.

	£18-00	£2-70	£20-70
(Each)	-83	-12	-95
(Per dozen; post free)	£8-65	£1-30	£9-95
(Each)	-40	-06	46
(Per dozen; post free)	£4-00	-60	£4-60
(Each)	£1-70	-25	£1-95
(Each)	£8-65	£1-30	£9-95



Order 2 or more Ten-Packs, and we will also give you a free EUROPHONIC Disk Directory and DiskWriter with every pack, so you need never wonder what's on your disks again.

SPECIAL BONUS

FREE Brushed chrome Paper Mate Ballpoint, with 5 to 9 Ten-Packs, 10 or more Ten-Packs, A GOLD Plated Paper Mate Ballpoint.

SPECIAL BONUS

ORDERING INFORMATION

U. K. DELIVERY, PACKING & INSURANCE (parcel post)

Disk Drive Head Cleaning Kits		INC. VAT	-75p
Mini-Disks (1-5 Ten-Packs)	each Ten-Pack		-95p
Mini-Disks (6 plus Ten-Packs)	each Ten-Pack		-65p
Disk Directories	(post free with disks)		-25p
DiskWriters	(post free with disks)		-25p
Plastic Library Boxes	(post free with disks)		-45p
Superluxe Disk Library			-95p

URGENT DELIVERY, PKG. & INS. (first class post)

Mini-Disks first	Ten-Pack	£1-80
Mini-Disks second & subsequent	Ten-Packs	£1-30

Payment by Credit Card

We accept BARCLAYCARD & ACCESS CARD, and make a small surcharge of 6%, on the total order value.

If your order is urgent, you may telephone your card number to us, and we can ship from stock the same day.

Please remember to state clearly, your card number, the holder's name & address, and where you want us to send the goods, & who to invoice.

Payment by Cheque

URGENT ORDERS: Send your order, with a first class stamp on the envelope, and for us to return your goods FIRST CLASS, see the First Class postal rates above. Please mark your order URGENT.

NORMAL ORDERS: Cheques with order, payable to EUROPHONIC Please. If you are a large establishment, and can not raise cheques without an invoice, please post or telephone us your order, and we will return a pro-forma invoice, for your accounts department to pay against.

ORDER FORM

To: **EUROPHONIC**

FREEPOST, Liphook, Hants, GU3 7BR.
No stamp required.

Please send me:

	Qty	Total
MEM 1 Ten-Pack at £18-95		
MEM 1D Ten-Pack at £23-45		
MEM 2D Ten-Pack at £26-96		
Verb 525 Ten-Pack at £19-95		
Verb 550 Ten-Pack at £29-95		
Verb 577 Ten-Pack at £31-63		
BASF 1 Ten-Pack at £22-95		
BASF1D Ten-Pack at £25-88		
BASF2D Ten-Pack at £29-45		
Cleaning Kit at £20-70		
SuperLuxe Library at £9-95		
Disk Directories at -95		
DiskWriters at -46		
Please add delivery & insurance	→	
TOTAL Value of Cheque enclosed	→	£

Please make cheques payable to 'EUROPHONIC'

Name:

Address:

What you say about us:

"Just received your 100 Verbatim Mini Disks, please send another 100."

"Your urgent deliveries to us, have saved us from many problems, please find enclosed a cheque for our third order of 100 BASF disks, we are delighted."

"Another 20 BASF please, and thank you for the sheer speed of service in settling impossible deadlines."

"Dear Sir, Please find enclosed cheque for yet another Ten-Pack, and thank you for your most courteous service."

"There must be something wrong with your disks, your prices are too low!"

The Co-Operative Society, Nuneaton.

Carlton Computers, Great Yarmouth.

A. T. Grant, Sevenoaks.

R. Pool, Reading.

anonymous & sceptical telephone enquirer.

• Circle No. 348

New from Acorn Computers Ltd

Two Computer Communications Systems

Econet

The lowest cost computer communication network system available in the world. A ten station network with 400K byte file station costs around £3,000 and as little as £50 for each additional station.

Cambridge Ring

A very high-speed (up to 20 million bits per second) ultra-low error rate, communications system for micro, mini and mainframe computers and their peripherals.

Now Acorn Computers can offer the very best in computer communications, covering all configurations, all price ranges. No other company can offer our experience and range of services.

For full details of Econet or Cambridge Ring please write to: Chris Curry, Acorn Computers Limited, 4a Market Hill, Cambridge CB2 3NJ.



• Circle No. 349



APPLE II with FORTRAN and CP/M

A powerful operating system for the engineer & scientist

- 48K APPLE II
- FLOPPY DISC DRIVE
- Z-80 SOFTCARD
- FORTRAN PACKAGE

£1350

+ VAT & CARRIAGE

01-843 1971



GRANATA
COMPUTER SYSTEMS

CENTURY HOUSE, HAVELOCK ROAD
SOUTHALL
MIDDX

• Circle No. 350

MAGTRONICS LTD.

MAGTRONICS LTD.
3 GOLDHURST TERRACE
LONDON NW6 3HX
PHONE 01-624 9847

ELECTRONIC COMPONENTS & COMPUTER SUPPLIES

DISKETTES

UNCONDITIONAL GUARANTEE

5.25"	MINI-DISKETTES 1 SECTOR (SOFT) PET, TRS80, ETC.	SINGLE SIDED PER 10 £16.50
5.25"	MINI-DISKETTE 10 SECTOR	SINGLE SIDED PER 10 £16.50
5.25"	MINI-DISKETTE 16 SECTOR	SINGLE SIDED PER 10 £16.50
5.25"	MINI DISKETTE 1 SECTOR	DOUBLE SIDED PER 10 £24.00
8"	SINGLE SIDED 26 SECTOR	SINGLE DENSITY PER 10 £18.00
8"	SINGLE SIDED 26 SECTOR	DOUBLE DENSITY PER 10 £24.00
8"	DOUBLE SIDED 26 SECTOR	SINGLE DENSITY PER 10 £30.00
8"	DOUBLE SIDED 26 SECTOR	DOUBLE DENSITY PER 10 £30.00

E. PROMS

1702A	500p
2708	350p
2716 (+5v)	450p
2732	2700p

CPU's

6502	750p
6800	650p
6802	1100p
8080A	450p
8085A	1100p

MEMORIES

2102-2L	120p
2114-2L	400p
2114-4L	250p
4116-2L	250p
6810	300p

SOCKETS L.P.

8 PIN	9p
14 PIN	10p
16 PIN	11p
24 PIN	22p
28 PIN	30p

INTERFACE

MC1488	80p
MC1489	80p
75451	75p
75452	75p
8T28	250p

ROMS

74S188	275p
74S189	275p
74S470	650p
74S471	650p
74S472	900p

C.MOS
SUPPORT DEVICES
TRANSISTORS
DIODES
ALL STOCKED
PHONE
FOR QUOTATION

DISK ORDERS ADD 90p AND COMPONENTS ADD 50p P&P. ADD 15% VAT TO TOTAL.

MANY OTHER TYPES OF HARD & SOFT SECTOR DISKETTES AVAILABLE. PHONE FOR QUOTATION.

MAGNETIC CARDS, DATA CARTRIDGES, DIGITAL CASSETTES ARE ALSO STOCKED.

OFFICIAL ORDERS FROM SCHOOLS, COLLEGES, UNIVERSITIES AND GOVT. BODIES ACCEPTED.

74LS SERIES	74LS26	22p	74LS76	36p	74LS125	50p	74LS163	1.00p	74LS221	1.20p	74LS279	65p	74LS375	1.20p	
	74LS27	22p	74LS78	45p	74LS126	50p	74LS164	90p	74LS240	1.75p	74LS280	1.75p	74LS377	1.60p	
74LS00	14p	74LS28	22p	74LS83A	70p	74LS132	60p	74LS165	1.00p	74LS241	1.75p	74LS283	90p	74LS378	1.30p
74LS01	14p	74LS30	20p	74LS85	80p	74LS133	40p	74LS166	1.70p	74LS242	1.75p	74LS290	95p	74LS379	1.80p
74LS02	15p	74LS32	26p	74LS86	40p	74LS136	50p	74LS168	1.70p	74LS243	1.75p	74LS293	95p	74LS381	3.80p
74LS03	15p	74LS33	28p	74LS90	40p	74LS138	65p	74LS169	1.70p	74LS244	1.50p	74LS295	1.45p	74LS386	80p
74LS04	16p	74LS37	28p	74LS91	99p	74LS139	70p	74LS170	1.85p	74LS245	2.50p	74LS298	1.45p	74LS390	1.20p
74LS05	22p	74LS38	28p	74LS92	72p	74LS145	110p	74LS173	1.10p	74LS247	1.40p	74LS324	1.85p	74LS393	1.20p
74LS08	20p	74LS40	22p	74LS93	60p	74LS148	1.70p	74LS174	1.00p	74LS248	1.80p	74LS325	3.00p	74LS395	2.00p
74LS09	22p	74LS42	65p	74LS95	100p	74LS151	80p	74LS175	1.00p	74LS249	1.40p	74LS326	3.00p	74LS396	2.00p
74LS10	18p	74LS47	75p	74LS96	110p	74LS153	60p	74LS181	280p	74LS251	1.30p	74LS327	3.00p	74LS398	2.75p
74LS11	22p	74LS48	85p	74LS107	45p	74LS154	1.60p	74LS190	1.00p	74LS253	90p	74LS352	1.80p	74LS399	2.00p
74LS12	25p	74LS49	100p	74LS109	35p	74LS155	65p	74LS191	1.00p	74LS257	90p	74LS353	1.80p	74LS424	4.50p
74LS13	40p	74LS54	25p	74LS112	35p	74LS156	75p	74LS192	1.00p	74LS258	1.20p	74LS355	50p	74LS445	1.85p
74LS14	50p	74LS55	25p	74LS113	45p	74LS157	60p	74LS193	1.00p	74LS259	1.60p	74LS366	65p	74LS447	1.85p
74LS15	25p	74LS63	1.50p	74LS114	45p	74LS158	60p	74LS194	1.00p	74LS260	45p	74LS367	65p	74LS490	1.60p
74LS20	20p	74LS73	45p	74LS122	75p	74LS160	90p	74LS195	1.10p	74LS261	4.25p	74LS368	65p	74LS668	1.05p
74LS21	22p	74LS74	28p	74LS123	75p	74LS161	75p	74LS196	1.20p	74LS266	45p	74LS373	1.55p	74LS669	1.05p
74LS22	22p	74LS75	36p	74LS124	145p	74LS162	1.15p	74LS197	95p	74LS273	1.75p	74LS374	1.80p	74LS670	2.50p

• Circle No. 351

CASTLE ELECTRONICS

MICRO COMPUTER CENTRE

Telephone Hastings (0424) 437875

TANGERINE

microtan 65 £69

Microtan 65 is the most advanced, most powerful, most expandable microcomputer available — It also happens to be the most cost effective.

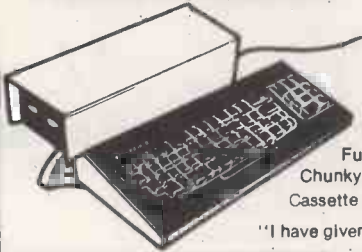

6502 Microprocessor 1K Tanbug 1K User RAM Full TV Display £79 (ready-built). 20-way KEYPAD—£10.
TANEX—£43
 1K 16 parallel 1/0 lines. Cassette Interface—1 serial 1/0 line. 2 x 16 BIT counter timers OPTIONS TK
 RAM total—32 parallel 1/0 lines. 4 x 16 BIT counter timers—RS232. 20MA current loop.
10K MICROSOFT BASIC—£49
 System Rack—£49 in black/ tangerine in brushed aluminium.
 Full Asclii Keyboard with numeric pad—£60.85. Cabinet available—£20. Lower Case option—£9.48.
 Chunky Graphics Pack—£6.52. Tanram Full Memory Expansion to 40K—£119.00. Mini Motherboard—£10.00.
 Cassette with counter—£21.70.

"I have given TANGERINE five bonus points for getting just about everything right"—E.T.I. Mag., May 1980.

COMMODORE PET

Everything has been said about PET— Britain's number one selling microcomputer. A full range of accessories and software, (both games and business), is held in stock.

- 8K Inbuilt Cassette—£399,
- 8K Large Keyboard—£425
- 16K Large Keyboard—£499
- External Cassette—£55
- Dual Disc Drive—£695
- Tractor Printer—£395



£399

CASSETTE SOFTWARE: Strathclyde Basic Course, Basic Basic Course, Invaders, Treasure Trove of Games 1 to 10 (10 selections of games), Basic Maths, Algebra, Statistical Packs and lots more!



£599



The Apple II+ is more powerful than its predecessors with built-in sound and high resolution graphics, which make it ideal for scientific and games applications.

- 16K—£599
- 32K—£649
- 48K—£659
- Epsom Printer—£349

- Cassette with counter—£21.70
- Disc drive without controller—£299
- Disc drive with controller—£349
- 16K add-on—£69

CARDS: Prototype/hobby card—£15, parallel printer interface card—£104, communications card—£130, high speed serial interface card—£113, Pascal language system—£299.

SHARP

MZ80 20K.....	£449
36K.....	£475
48K.....	£495
Printer.....	£475
Dual disc drive.....	£715

VIDEO GENIE SYSTEM

Easy-to-use BASIC language means that programmes are easily written for specific applications. Many pre-recorded programme tapes are available. TRS80 software compatible. Great scope for the home, introducing the whole family to the computer age.

£299

BUSINESS SOFTWARE SALE

PETACT Purchase Ledger (Disc.)	£75.00
PETACT Sales Ledger (Disc.)	£75.00
Commodore Word Processor III (Disc)	£75.00
Commodore Stock Control (Disc)	£75.00
Commodore Sales/Purchase/Nominal Ledger.....	£500

Further details of business software available on request

BOOKS (No V.A.T.)

Basic Computer Game—£5.50, Instant Basic—£7.20, Pet Revealed—£10.00, Library of Pet Subroutines—£10.00, Your First Computer—£5.95, Guide to Basic Programming—£8.85, Basic Basic—£6.50, Advanced Basic—£6.00, Basic Programming Z80—£8.95, 6520 Applications Book—£7.95 and lots more. Send for full list of microcomputer and electronic books.

PET SCIENTIFIC & INDUSTRIAL APPLICATIONS

16-channel A/D converter	£300
16-channel Relay Unit	£350
8-channel D/A Converter	£350

NASCOM

NASCOM 1	£125 (Kit form)
NASCOM 1	£140 (Ready-built)
NASCOM 2	£225
IMP PRINTER	£325

SINCLAIR ZX80 TAKEN IN PART-EXCHANGE FOR ALL MICROS

ATARI Computer due in May

ALL PRICES—ADD 15% VAT. DELIVERY: POSTAGE/PACKING WILL BE NOTIFIED BARCLAYCARD AND ACCESS ORDERS TAKEN BY PHONE

CASTLE ELECTRONICS

7 CASTLE ST., HASTINGS, EAST SUSSEX TN34 3DY Telephone: Hastings (0424) 437875
 Shop hours 09.00 to 17.30 Mondays to Saturdays Personal callers welcome

• Circle No. 352

TRIDATA COMPLETE BUSINESS SOFTWARE PACKAGES

- * SALES INVOICING
 - * SALES LEDGER
 - * PURCHASE LEDGER
 - * NOMINAL LEDGER
 - * PAYROLL
 - * STOCK CONTROL
- for use on
- * TANDY TRS 80
 - * TANDY TRS 80 Mk. II
 - * SHARP MZ-80K
 - * PET AND SUPERPET
 - * APPLE

Our business packages are supplied with master diskettes, detailed operating manuals and training procedures. For small businesses and traders with up to 700 employees, 9,999 customers and 9,999 suppliers, our proven programs written by experienced DP professionals provide fast, simple control, with built in security routines for prevention of unauthorised use, abuse or mishandling. Over 550 Tridata business systems are now in use.

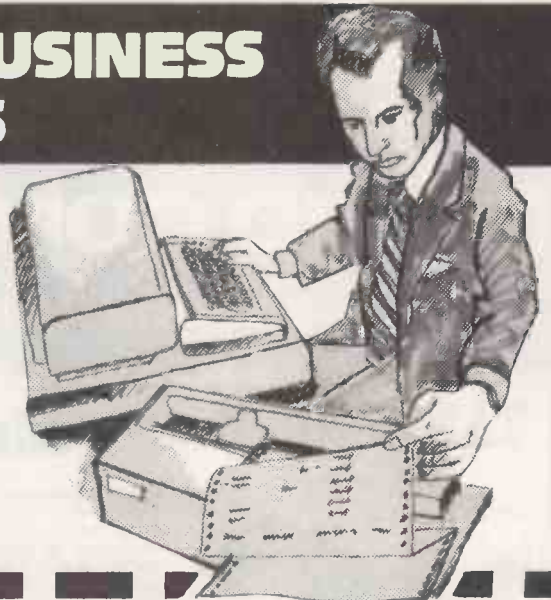

TRIDATA WARRANTY
Every Tridata program has a written 12 month warranty and can be automatically updated to conform to any legislation that may alter your accounting procedures.



SEND THE COUPON TODAY
OR TELEPHONE
021-622 6085

TRIDATA MICROS LTD., Smithfield House, Digbeth, Birmingham

Send me details of the Tridata Business Software Systems. I am interested in

PURCHASE LEDGER	For TANDY TRS 80
SALES LEDGER	TANDY TRS 80 Mk. II
PAYROLL	SHARP MZ-80K
NOMINAL LEDGER	PET
SALES INVOICING	SUPERPET
STOCK CONTROL	APPLE

Name _____ PCS/81
Company _____
Address _____

TRIDATA MICROS LTD., Smithfield House, Digbeth, Birmingham B5 6BS

• Circle No. 353



CASH AND CARRY SUPERDEALS

- | | |
|---|--------------|
| SUPERBRAIN 64K | £1650 |
| QUAD DENSITY SUPERBRAIN | £2250 |
| NEC SPINWRITER | £1600 |
| DIABLO 630 | £1600 |
| CROMENCO – (All hardware and software in stock for immediate delivery) | |

MATRIX PRINTERS

ANADEK
OKIDATA
EPSON

The quietest, most reliable printers available – 40, 80 or 132 characters per line with graphics

Telephone: 01-840-1926



MICROPRO

- | | |
|---|-------------|
| WORDSTAR
The Ultimate Word Processing Package | £250 |
| DATASTAR
Forms Generation, Data Capture, Validation and Retrieval | £180 |
| MAILMERGE
Mailing List, Standard Letters, etc. | £80 |
| SUPERSORT
Search, Sort and Select | £125 |

PASCAL, BASIC FORTRAN, PL/I and other CP/M software

Dealers: Best Discounts

Call for Details
Telephone: 01-840-1926

• Circle No. 354

PRESTEL.

THE BIGGEST BREAKTHROUGH IN COMMUNICATION SINCE THE TELEPHONE AND TELEVISION.



- 180,000 Pages of information instantly available
- Ask Prestel a question and up pops the answer in seconds in full colour on your own T.V. screen

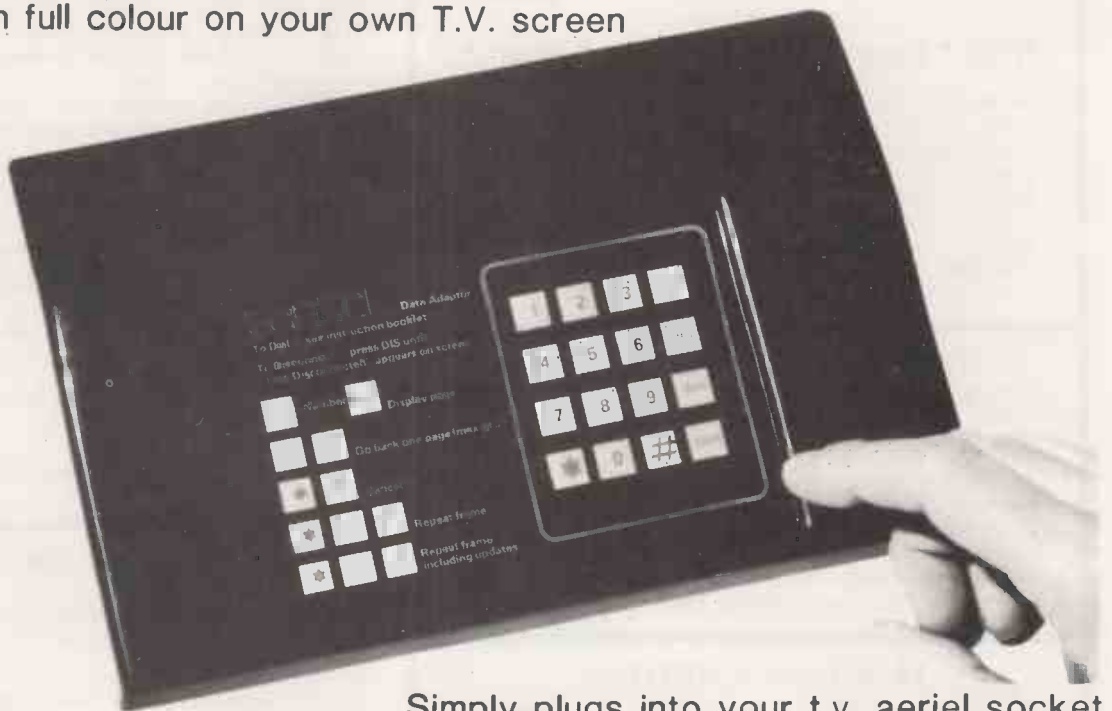

EXPENSIVE?

NOT ANY LONGER WITH

TANTEL

BY TANGERINE

Only £170 + VAT

Simply plugs into your t.v. aerial socket

Tantel requires a jack socket on your telephone line (available from the Post Office)

PC5/81

PLEASE SEND METANTEL ADAPTORS
 I ENCLOSE CHEQUE / P.O. TO THE VALUE OF
 OR DEBIT MY ACCESS/BARCLAYCARD No.

NAME

ADDRESS

.....

PAYABLE TO TANGERINE COMPUTER SYSTEMS LIMITED

FOR FURTHER INFORMATION PLEASE SEND A 12p STAMP TO :-
TANDATA MARKETING
FOREHILL WORKS
ELY CAMBS CB7 4AE

• Circle No. 355

CP/M SOFTWARE

from

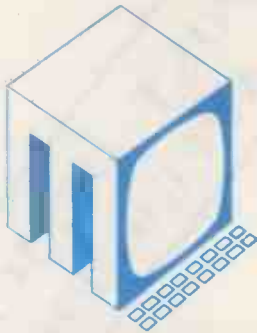

METROTECH

WORD PROCESSING

WORD-STAR™ is the most complete integrated word processing software system ever seen on a microcomputer. In less than six months more than four thousand people have proudly purchased WORD-STAR.

WORD-STAR 2.0 £255/£30
WORD-STAR 2.0 with MAILMERGE £315/£40

NEW * Commercial Operating System * NEW

At last a secure commercial environment can be created under CP/M. COSY offers a true **COBOL compiler**, ISAM files, enhanced disk I/O, screen formatting and printer spooling. Requires Z80 or Z80A processor.

COSY — including COBOL compiler £450
COSY — run time system £200
PSORT — utility sort £50
FDUMP — utility file dump £30

One manual for all the above £15.

INTEGRATED BUSINESS SYSTEMS

Written specially for the U.K. market, Version 2.0 of GRAFFCOM'S Integrated Small Business Software is now available for both floppy (ISBS-F) and hard (ISBS-W) disk systems. Modules available are: Payroll, Company Sales, Company Purchases, General Accounting, Stock Control, Order Entry and Invoicing, Name and Address, Time Recording, Lease, Rental and HP.

Prices are available on request, discounts quoted for bundles of the above systems. Manuals £35 each.

LANGUAGES/UTILITIES

CBASIC II
 Commercial Disk Extended Basic £75/£20
SBASIC
 Compiler Structured Basic £175/£30
SUPERSORT I £125/£20
WORD-MASTER Superior Text Editor £75/£20
MET/TWAN Index sequential file
 Access in CBASIC II £55/£15

MICRO DATA BASE SYSTEMS

MDBS is a database system offering full network **CODASYL**-oriented data structures, variable length records, read/write protection, one-to-one, one-to-many and many-to-many set relationships. Add on features are: an interactive report-writer and query system, a dynamic restructuring system and a recovery-transaction logging system.

MDBS prices start from £600-£35
 Primer manual £5

COMMUNICATIONS

BISYNC-80/3780 and **BISYNC-80/3270** are full function IBM 2780/3780 and 3270 emulators for microcomputers.

BISYNC-80/3780 gives you a Remote Job Entry terminal for the price of a micro!

BISYNC-80/3270 combines the local processing power of a micro with a sophisticated screen capability. Make your dumb terminal smart!

I/O Master is a superb S100 buffered I/O board which supports 3780 and teletype communications, plus serial and parallel peripherals.

MET/TTY will connect your micro to a timesharing service in simple teletype emulation.

BISYNC-80/3780 £275/£15
BISYNC-80/3270 £275/£15
MET/TTY £95/£15
I/O Master Board £225/£20

DATA MANAGEMENT

SELECTOR III-C2

An easy to use Information Management System; requires CBASIC II £185/£30

SELECTOR IV

An advanced Information Management System; requires CBASIC II £275/£35

DATASTAR

Powerful data entry, retrieval and update system £195/£30

FINANCIAL REPORTING

REPORT WRITER

You input the values — Report Writer will perform your calculations and produce a report with your headings, totals and summaries £150/£15

GLECTOR

General ledger option to Selector III; Requires Selector III and CBASIC II 7£185/£30

All software is **Ex-stock** and available on standard 8" disks or 5" disks for Cromemco Z2H, North Star Horizon, Vector MZ, Superbrain and Dynabyte.

- * Add 15% VAT.
- * Postage and Packing £2 per order.
- * State which disk type and size.
- * All orders prepaid.

Telephone orders welcome for Access, Barclaycard, American Express or Diners Club.

CALL 0895 58111 Ext. 247 or 269

or write to:

METROTECH MAIL ORDER
WATERLOO ROAD
UXBRIDGE
MIDDLESEX UB8 2YW

enclosing cheque, PO's payable to METROTECH

tml WORD-STAR is a trademark of Micropro.

Prices are shown as Software with manual/Manual only.

Prices correct at time of going to press.

METROMECH are sole U.K. distributors of DYNABYTE microcomputer systems.

• Circle No. 356

the printer people

Esher (0372) 62071

Tec Daisywriter

The low-cost daisywheel printer

£1050



- * 25 cps letter-quality output
- * Standard 96-character daisywheels
- * 136-column/15" print width
- * Programmable forms handling
- * Parallel interface; RS-232 option

Epson MX80



£359

Complete range of interfaces

- * 9x9 dot matrix
- * Fast bidirectional printing
- * ASCII and graphics, with £ sign
- * Bold, expanded, condensed print
- * Parallel interface standard

MX80FT friction/tractor feed: **£399**

MX70 with 7x5 matrix: **£259**

Centronics 737

£349



Letter quality printer

- * 7x9 and 11x9 dot matrix
- * 3-way paper handling, up to 8 1/2"
- * Proportional characters/spacing
- * Up to 80 characters/second
- * Parallel standard; serial option

OKI Microline 80



£329

The quiet workhorse

- * ASCII and graphics characters
- * 9x7 dot matrix
- * Condensed, double width print
- * Friction or pin feed
- * Rugged, quiet and reliable
- * Parallel interface standard

Microline 82 — £399

- * Fast, bidirectional, logic-seeking

* Additional forms control

Microline 83 — £699

- * commercial unit
- * 120 cps, 15" paper width

TVI 912C terminal

£475



Fully intelligent terminal

- * 24x80 character display
- * Dual intensity, blinking, reversed, underline, and protected fields
- * Full upper/lower case ASCII
- * Separate numeric keypad

TVI 920C (illustrated) with extended set of function keys: **£550**

Anacom 150



£699

The reliable commercial printer

- * 150 characters per second
- * 9x9 matrix, upper and lower case
- * Up to 15" paper width
- * Full forms control
- * Centronics parallel/RS232 serial

NEC Spinwriter

£1485

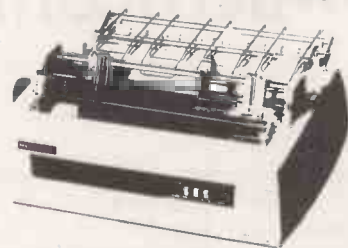

The word-processing printer

- * Letter quality for word-processing
- * 128-character easy-change 'thimble'
- * 55 chars/sec — friction/tractor feed
- * RS232, parallel interface versions

the best prices for peripherals

All prices quoted exclude VAT and delivery.

Educational and dealer discounts are available — please phone 0372 62072 for details.

North of England end users: contact Northern Micro on Holmfirth (0484 89) 2062

NORTHAMBER

Importers, Distributors and Wholesalers

Great Oak House, Albany Close, Esher, Surrey
Telephone: Esher (0372) 62071

AIM 65 DANCES TO A NEW DISK

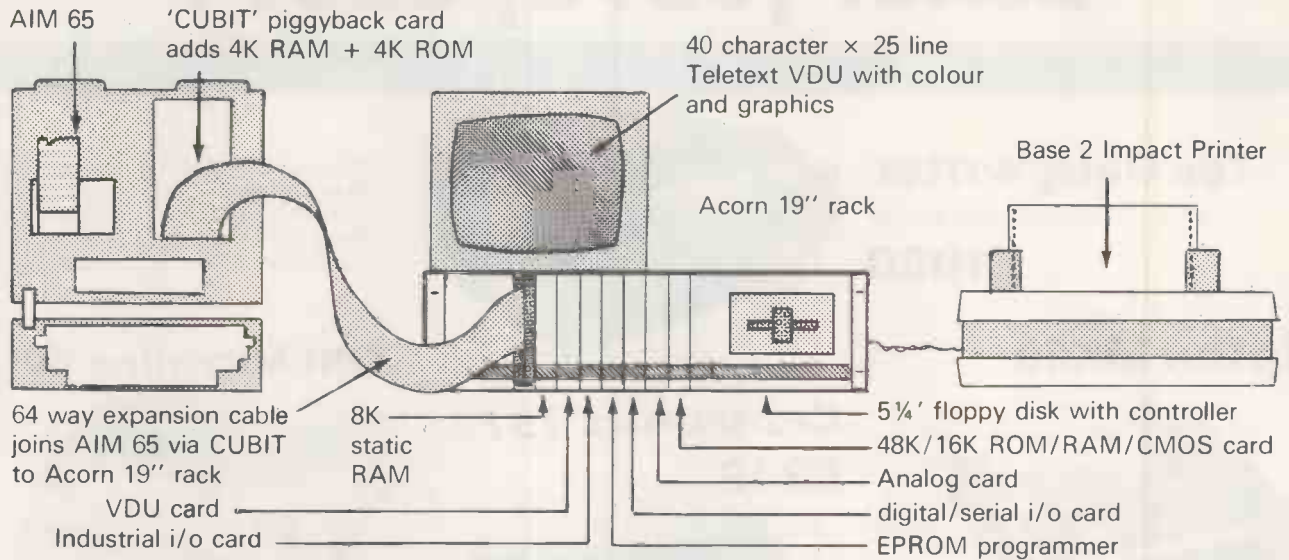

£600 buys a complete single disk extension to the AIM 65

This is the first conveniently packaged AIM 65 disk system to be available, and in the same sensible Eurocard presentation it offers memory expansion, impact printer interface, colour VDU, EPROM programmer, digital and analog i/o, and more. In addition, the owner of this hardware can run Acorn software, which includes BASIC, disk assembler, word processor and business accounting, and can run a 6809 microprocessor card in the same rack.

CONTROL — ALL ROCKWELL SYSTEMS
UNIVERSAL — ALL ACORN SYSTEMS
LTD SUPPLY — EXTENSIONS TO BOTH

Control Universal Ltd.
 11-15 Bush House,
 Bush Fair, Harlow, Essex
 Tel: 0279 31604

• Circle No. 358

Xitan: South Coast Leaders in Microcomputer Support Application and Service

Xitan In Business

Xitan provide cost effective computer support for wide ranging business organisations; from low entry level, stand alone systems for the smaller business, to integrated multuser/multitasking systems

Xitan In Science and Research

Xitan support scientific and research users in universities, colleges, government and independent research establishments with comprehensive practical experience embracing hardware, system, and applicational software.

XITAN SYSTEMS

23 Cumberland Place
 Southampton SO1 2BB
 Tel: 0703 38740



Cromemco SHARP North Star Horizon comart

• Circle No. 359



Number one for PET in London.

01-579 5845

The news is travelling fast amongst the professionals that Adda are the Number One people to go to for Commodore PET microcomputer systems.

Commodore's new generation of desk-top computers and software - including packages for accountants, solicitors and doctors - can be made to realise their full potential with professional advice from Adda. This, together with exceptional standards of service back-up, will help you stay on top and in complete control of the latest advances in microcomputing.

WORD PROCESSING FROM AS LITTLE AS £2900

With the WORDCRAFT 80 programme, Adda can show you how to make use of a Commodore Business System in the dual role of a fully fledged word processor. There's capacity for 250-300 pages of text, the functions you'll find on very much more expensive word processors, and a wide choice of output printers including daisy-wheel. Add on the DMS file management programme for £195 and you can access several thousand names and addresses for personalised mailing. Mu-Pet enables you to build up a multi-terminal word

processing system linking from three to eight microcomputers to one Commodore disc drive and printer for as little as £595.

CALCULATOR, PEN AND PAPER - ALL IN ONE - WITH VISICALC

When you need to work things out on paper, using a calculator, the VisiCalc programme can do it so much easier and quicker on computer - and instantly display the answers you are looking for. And you can get a hard printout later. The applications are numerate and innumerable - get Adda to show you.

MEDICOM PRACTICE MANAGER - JUST WHAT THE DOCTOR ORDERED

Medicom Practice Manager provides the information needed

to ease the clerical workload and aid the running of an efficient practice. Designed by doctors in general practice, this practical computing system controls and prints repeat prescriptions, maintains the age/sex register and monitors patient care - in a complete package costing less than £3000. A pharmacy stock control system can be added for just £400.

Find out more about how these developments can best be employed in the professions - with professional advice from Adda.

Phone 01-579 5845 today.

adda

Adda Computers
14 Broadway
West Ealing
London W13 0SR
Entrance in
Kirchen Road
01-579 5845



we add up to a great deal.

• Circle No. 360



TRS-80 OWNERS!



LEVEL II CASSETTE

GAMES

Adventures - Special Sampler £5.50
 Adventureland* £9.50
 Pirates Adventure* £9.50
 Mission Impossible* £9.50
 Voodoo Castle* £9.50
 The Count* £9.50
 Strange Odyssey* £9.50
 Mystery Fun House* £9.50
 Pyramid of Doom* £9.50
 Ghost Town* £9.50
 Savage Island* £9.50
 Air Raid* £8.50
 Air Traffic Control* £7.50
 Amazon Mazes £5.50
 Android NIM £9.50
 Backgammon £6.50
 Balloon Race £6.50
 Barricade* £8.50
 Baseball £6.50
 Battleship £7.50
 Bee Wary £9.50
 Bingo £4.50
 Bowling (Ten Pin) £6.50
 Breakaway £4.50
 Bridge Partner £12.00
 Cribbage £6.50
 Death Dreadnaught* £9.50
 Dogstar £6.50
 End Zone II £6.50
 Fastgammon* £12.00
 Galactic Blockade £6.50
 Galactic Empire £9.50
 Galactic Revolution £9.50
 Galactic Trader £9.50
 Galaxy Invasion* £9.50
 Game of Life* £6.50
 Gammon Challenger* £9.50
 Gangster £5.50
 Hangman £4.50
 I Ching £6.50
 Interlude* £10.50
 Invasion Orion* £12.00
 Invaders from Space* £9.50
 Kamikaze £6.50
 Kriegspiel II £9.50
 Life Two £9.50
 Lost Dutchman's Gold £9.50
 Lost Ship Adventure* £9.50

MODEL I

Mastermind II* £5.50
Mean Checkers* £11.00
Morloc's Tower* £9.50
Noughts & Crosses £4.50
Othello III £6.50
Pentominoes £6.50
Pinball* £9.50
Pork Barrel £6.50
PR Dogfight £6.50
Pre School Games £6.50
Robots £4.50
Round The Horn £6.50
Safari £6.50
Santa Paravia £6.50
Sargon II* £18.50
Ship Air Battles £5.00
Slalom £5.00
Snake Eggs £9.50
Space Battles £9.50
Starfleet Orion* £12.00
Star Trek III.5 £9.50
Super Nova* £9.50
Tarzan £9.50
Time Trek* £12.00
Trek 80 £6.50
Trolls Gold £4.50
Up Periscope £9.50
Warfare I £5.50
X-Wing Fighter II £6.50

EDUCATIONAL
 Spelling Builder £12.00
 All other PDI Pgms £9.50

BUSINESS & UTILITIES
 Accounts Receivable II £13.50
 Amateur Astronomer £9.50
 APL-80* £9.50
 Basic 1P* £11.50
 Basic Toolkit* £11.50
 Biorythms £4.50
 Calendar Functions £7.50
 Cash Register £6.50
 Copycat £9.50
 Data Base II £17.50
 Debug* £12.50
 Editor Assembler Plus* £18.50
 Electric Pencil* £50.00
 Electronics Assistant £6.50
 EMU 6502* £16.00
 ESP Tester £4.50
 File Handling £7.50

Finance Pack £7.50
Flight Simulator* £15.00
Forth* (incl. Primer) £37.50
GSP* £17.50
General Accounting £8.50
Ham Radio £6.50
Histogram/Scattergram £7.50
Home Finance £6.50
Infinite Basic* £31.00
Infinite Business* £18.50
Instant Calculator £7.50
Inventory Control £11.00
Inventory 'S' £16.00
IRV* £16.50
Keyboard 80* £7.50
KVP* £9.50
Level III Basic* £30.00
Linear Programming £7.50
Magic Paper Calculator £9.50
Mathdrill £5.00
Maths Library I £8.50
Maths Library II £8.50
Memdump £8.50
Microtext Editor £6.50
Mortgage Calculator £5.00
Pascal* £26.00
Periodical X-REF £9.50
Personal Finance £6.50
Pilot 2.2* £9.50
Pre-Flight £9.50
Remodel & Proload* £23.00
Renumber* £6.50
RPN Calculator £6.50
RSM 2 Monitor* £16.00
SCRIPSI* £39.95
Screen Hold* £6.00
Statistics £6.50
S.T.A.D.* £16.00
ST-80* £30.00
Super Simon £6.50
Super T-Legs* £6.50
T-Step* £7.50
System Copy* £8.50
T-Short* £6.50
T-Short** £12.50
Tarot Cards £6.50
Teachers Assistant I £9.50
Teachers Assistant II £9.50
Timser* £9.50
Tiny Comp £12.50
TRS80 Opera* £6.50

Typing Tutor £11.50
Ultra Mon* £15.00
X-Bar* £9.50
76 Basic Programs £23.00
Manual for Above £7.00
Library 100 £40.00

DISK

Accounts Receivable II £40.00
Advanced Personal Finance £15.50
Amateur Radio System £15.50
APL 80 £30.00
Auto Disk Directory £9.50
Basic Compiler £110.00
CCA Data Management £52.50
Comproc £13.50
Data Base II £30.00
DCV-1 £8.50
Dosort £25.00
Dynamic Data Base £22.50
Electric Pencil £75.00
File Manager 80 £30.00
Floppy Disk Diagnostic £13.50
Forth (incl. Primer) £45.00
Inventory 2.3 £40.00
Inventory II £50.00
Inventory 'S' £40.00
KVP Extender £16.00
Mailist IV £45.00
Newdos 80 £87.50
Newdos + £47.50
Newdos £30.00
Pencil PAL £12.00
Roots £14.50
SCRIPSI* £65.00
Simplify It £15.00
ST80D* £45.00
ST80D III* £85.00
SUPERSCRIPT* £17.50
Visicalc* £65.00
Taranto & Associates Conversion of Osbourne & Associates Business Programmes £90.00
Accounts Payable £40.00
Cash Journal (for G/L) £90.00
Invoicing £90.00
Accounts Receivable £90.00
General Ledger £90.00
Complete Co-ordinated System with Manuals £350.00

MODEL II

CPM 2.2 X £165.00
CBasic (CPM) £80.00
Disk Sort Merge £87.50
Development System £70.00
G.S.F. £30.00
Pascal from £100.00
Reference II £30.00
RM Cobol from £350.00
RSM II Monitor £30.00
Supersort III (CPM) £80.00
Utility Package £87.50
Hard Disk Operating Sys. £250.00

WORD PROCESSORS
Electric Pencil II (CP/M) £200.00
Electric Pencil II TRSDOS £225.00
Magic Wand (CP/M) £230.00
Wordstar (CP/M) £275.00

BUSINESS SYSTEMS
Accounting from £150.00
Mailist from £100.00
Medical from £100.00
Property Analysis £175.00

CP/M USERS GROUP
 23 Volumes Each £12.00

ALL PRICES INCLUDE VAT AT 15% PACKAGING & RETURN POSTAGE TO U.K. ADDRESSES. PRICES TO OVERSEAS ADDRESSES INCLUDE RETURN AIRMAIL SEND £1.00 FOR NEW DESCRIPTIVE CATALOGUE.

*Denotes Machine Language TRS-80 Trademark of Tandy Corp. CP/M Trademark of Digital Res. C-Basic Trademark of Compiler Systems.



MICROCOMPUTER APPLICATIONS
 11 RIVERSIDE COURT,
 CAVERSHAM,
 READING RG4 8AL,
 ENGLAND.
 TEL: (0734) 470425

ALL TANDY HARDWARE AND SOFTWARE AVAILABLE AT CATALOGUE PRICES

Intex DATALOG LTD COMPUTERS

MICROPAY-200 £195.00 + VAT

Micropay-200 is a complete payroll System designed to run on a COMMODORE 32K PET microcomputer, interfaced to dual floppy disk drives and a printer.

The System provides:

1. Weekly/monthly payslips
2. Summary page of all payments and deductions that month
3. Summary page of all payments and deductions for the tax year to date
4. Weekly/monthly cash analysis slip for all cash payments made
5. Monthly summary of all payments and deductions
6. Year end summary of all payments and deductions

STOCK CONTROL 3750

Stock Control 3750 is a complete stock control system designed and written to meet the needs of a small business.

It will accommodate up to 3747 stock items and runs on a COMMODORE PET micro-computer interfaced to a printer and COMPU/THINK disk drives.

The System incorporates programs to:

1. Set up a Supplier file.
2. Set up Stock files.
3. Copy Data files.
4. Insert/delete stock records.
5. Insert/delete supplier records.
6. Update/display stock file.
7. Update/display supplier file.
8. Print stock list.
9. Print supplier list.
10. Print reorder report.
11. Print stock movement report.
12. Print stock valuation report.

And perform other useful routines.

Stock Control 3750 is fully protected from misuse and can easily be used by someone with no knowledge of computers or their operation.

The System costs £195.00 + V.A.T. and this price includes a full back-up and advisory service from INTEX DATALOG.

FOR FULL SPECIFICATION WRITE TO:
 INTEX DATALOG LTD, DEPT PC1280
 EAGLESCLIFFE IND. EST., EAGLESCLIFFE
 CLEVELAND TS16 0PW. TEL: 0642 781193

MAIL ORDER SERVICE

BARCLAYCARD - MAILORDER - ACCESS

ITEM	PRICE	TOT. INC. VAT
*** DUSTCOVERS		
PET - ALL MODELS	5.75	6.90
T 143 PRINTER	5.75	6.90
ANADEX DP8000	3.50	4.35
CBM 3040 DISK	3.50	4.35
CBM 3022 PRINTER	3.99	4.80
COMPUTHINK DISK	3.00	3.75
ACOUSTIC COVER FOR CBM 3022 PRINTER	49.00	62.00
*** D/D DISKETTES IN FREE CASE		
BASF ACCUTRACK LIBRARY CASE	35.00	40.83
*** BLANK CASSETTES	30.00	35.08
C15 IPER 10I	3.50	4.60
C60 IPER 10I	4.00	5.75
*** CONNECTORS	6.00	8.05
USER/IEEE PORT	1.30	1.78
CASSETTE PORT	.99	1.43
USERPORT COVER	2.50	3.16
MALE 'D' PLUGS	2.50	3.16
FEMALE 'D' SOCKETS	3.50	4.31
'D' CONNECTOR COVERS	2.50	3.16
*** RIBBONS		
TELETYPE 43	7.72	9.17
ANADEX DP8000	2.75	3.45
ANADEX DP9500/1	15.00	18.40
CBM 3022	2.75	3.45
QUME FABRICI	4.25	5.18
QUME (CARBON M/S)	4.50	5.65
QUME (CARBON S/S)	5.00	6.04
DAISY WHEELS		
QUME SPRINT S	6.50	7.76
*** PROGRAMMERS TOOLKIT		
*** SPECIAL OFFER		
OLD ROMS BK	65.00	75.90
NEW ROMS BK	55.00	75.90
NEW ROMS 8/1B/32K	45.00	52.90

PROKIT 1

PROKIT 1 - PROGRAMMERS AID.

ADDS THAT TOUCH OF PROFESSIONALISM TO EVERY PROGRAM YOU WRITE. NUMERIC INPUT ROUTINES - AUTOMATICALLY ADD LEADING AND TRAILING ZERO'S AND RESPOND ONLY TO NUMERIC KEYS AND DECIMAL POINT. GENERAL INPUT ROUTINES - SET THE LENGTH OF FIELD REQUIRED, SPECIFY WHICH CHARACTERS YOU WANT PET TO RESPOND TO AND ALL OTHERS WILL BE IGNORED. DATE INPUT ROUTINE - THE PROGRAM WILL NOT CONTINUE UNTIL YOU HAVE ENTERED A VALID DATE. STRING SEARCH ROUTINE - FINDS A MATCHING SUBSTRING WITHIN A A STRING ENABLES YOU TO USE ON . . . GOTO WITH ANY CHARACTERS, NOT JUST NUMBERS. SCREEN ROUTINES - CAN STORE SCREEN DISPLAYS IN MEMORY AND RETRIEVE THEM IN A FLASH - SUPER FOR MENUS AND GAMES! PROKIT 1, DEFINITELY THE BEST THING FOR PROGRAMMERS SINCE THAT OTHER KIT! AVAILABLE ON DISK OR TAPE, READY TO INCORPORATE IN YOUR OWN PROGRAMS. PRICE £40.25 INC. VAT AND POSTAGE



• Circle No. 361

SUMLOCK BONDAIN

Makes the decisions easier



HEWLETT PACKARD SERIES 80 GRAPHICS SYSTEM . . .



DISCOVER THE FULL PROFESSIONAL POWER OF HEWLETT PACKARD'S PERSONAL COMPUTER

The New HP83A personal computer has the same powerful facilities as the HP85A excluding the cartridge and internal printer. This allows a full system to be installed at a much lower price. Add the HP2631B high-speed, high quality printer, the HP7225 high-resolution graphics plotter and the HP82900 5¼" flexible disc drives providing up to 270K bytes of formatted storage. The NEW HP9111A GRAPHICS TABLET can now also be added. Ask for a demonstration. It's your personal computer system. You decide which HP peripherals you need. See both the HP85A and HP83A and the new peripherals in action. Getting your hands on so much professional computing power was never so easy.

... INCLUDES NEW HP-83A PERSONAL COMPUTER FLEXIBLE DISC MEMORY, PRINTER AND GRAPHICS PLOTTER



**HEWLETT
PACKARD**



HEWLETT PACKARD'S NEW HP-41CV HANDHELD SYSTEM . . .

HP 41C PRICE DROP!

HP41C	£129.95
CARD READER	
HP82104A	£109.95
PRINTER	
HP82143A	£199.95
MEMORY MODULE	
HP82106A	£18.00
NEW QUAD RAM (4 times capacity of standard memory module) HP82170A	£54.00
NEW HP-41CV	£169.95

MAKE FURTHER
SAVINGS!
PACKAGE DEALS
(including card reader
and printers)

HP-41C	£425.00
HP-41CV	£460.00

All prices include postage, packing and VAT. Barclaycard/Access accepted by phone. Request full competitive price lists. Above prices refer to UK only.



... featuring memory that can accommodate up to 2,000 lines of program or five times that of the HP-41C. Thanks to the increased memory, HP-41CV owners can use the input/output parts for peripherals instead of memory modules. Shown here are the card readers and printers peripherals.

SUMLOCK BONDAIN

Head Office: 263-269 CITY ROAD, LONDON EC1V 1JX
and at CANNON STREET STATION, LONDON EC4
Tel 01-250 0505 Telex 299844

• Circle No. 362

TOMORROW TODAY

at Birmingham Computer Centre

Commodore official distributors

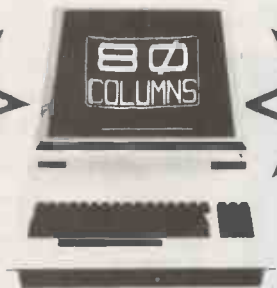

4008/16/32 8032 — 8050

NEW DAISYWHEEL PRINTER IN STOCK
NEW MATRIX PRINTER NOW IN STOCK
THE RELIABLE VALUE FOR MONEY SYSTEM
WITH FULL AFTER SALES SUPPORT.



Apple authorised distributors
The sophisticated quality system with
a reputation for advanced design and
innovation.

SHARP Z80K



The incredible computer system
now available ex-stock including the
New Dual Drive Double Sided Floppy Disk.

THE ULTIMATE IN DAISYWHEEL PRINTERS
RICOH.RP 1600

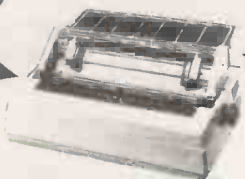

THE BEST WORDPROCESSOR.PRINTER.AVAILABLE
DEALER ENQUIRIES WELCOME
CAMDEN ELECTRONICS LTD
MICROCOMPUTER SYSTEMS

462 COVENTRY ROAD • SMALL HEATH • BIRMINGHAM B10 0UG
Telephone: 021-773 8240 or 021-772 5718 • Telex: 335909 (Camden G)

• Circle No. 363

OSI
SYSTEMS



Norlett House
Dormer Road
Thame
Oxon OX9 3UC
Telephone (0458)
47007 (24 hr)

YOUR COMPLETE OHIO SCIENTIFIC SERVICE

HERE ARE FIVE VERY GOOD REASONS FOR CALLING US —

- O.S.I. SYSTEMS**
— including the popular SUPERBOARD II and CHALLENGER 4P as either cassette or disc based systems.
- O.S.I. SOFTWARE**
— cassette and disk based software covering a broad spectrum of uses. Some of the cassette based software can also be run on the U.K.101.
- BEAVER SOFTWARE**
— Business, educational and entertainment software — professional programs with full listings and documentation. Also available for other systems — especially the U.K.101.
- BEAVER PROGRAMMING AIOS**
— including Video Workpads, BASIC workpads, Machine Code Workpads, Cassette Index cards and labels and Blank Cassettes, all available for OSI, U.K.101, and TRS-80.
- BEAVER EXPANSION**
— Economy memory expansion using motherboard and slot-in 8K RAM boards, 8K EPROM boards, floppy control board & shortly, PROM Programmer board. Buy as much as you need when you need it.



CALL OR WRITE... NOW!



• Circle No. 364

Old tricks for new Pets...

COMMAND-O is a FOUR KILOBYTE Rom for the 4000/8000 Basic 4 Pets with all the "Toolkit" commands RENUMBER (improved), AUTO, QUMP, DELETE, FIND (improved), HELP, TRACE (improved & includes STEP), and OFF - plus PRINT USING - plus four extra disk commands INITIALIZE, MERGE, EXECUTE, and SEND - plus extra editing commands SCROLL, MOVE, OUT, BEEP, and KILL - plus SET user-definable soft key, 190 characters - plus program scroll up and down - plus 8032 control characters on key. Ask for Model CO-80N for the 8032 or CO-40N for the 4016/4032. £50.00 plus Vat

New tricks for old Pets...

DISK-O-PRO is a FOUR KILOBYTE Rom that upgrades 2000/3000 Pets, but lets you keep all your old software - including Toolkit. As well as REPEAT KEYS and PRINT USING, you get all the Basic 4 disk commands CONCAT, OPEN, CLOSE, RECORD, HEADER, COLLECT, BACKUP, COPY, APPEND, OSAVE, DLOAD, CATALOG, RENAME, SCRATCH and DIRECTORY - plus extra disk commands INITIALIZE, MERGE, EXECUTE and SEND - plus extra editing commands SCROLL, MOVE, OUT, BEEP and KILL - plus SET user definable soft-key, 80 characters - plus program scroll-up and scroll-down. We recommend the 4040 disk or upgraded 3040 for full benefit of disk commands. Ask for Model DOP-16N for new Pets 2001-3032, and 2001-8 with retrofit Roms & TK160P Toolkit. £50.00 plus Vat, other models available.

PRONTO-PET hard/soft reset switch for the 3000/4000 Pets. We don't think you'll "crash" your Pet using our software, but if you do the Pronto-Pet will get you out! Also clears the Pet for the next job, without that nasty off/on power surge. £9.99 + Vat

and no tricks missed!

KRAM Keyed Random Access Method. Kid your Pet it's an IBM VSAM disk handling for 3032/4032/8032 Pets with 3040/4040/8050 disks means you retrieve your data FAST, by NAME - no tracks, sectors or blocks to worry about. Over 2,500 users worldwide have joined the "Klub"! Now you can too, at the 1981 price, £75.00 plus Vat.

SPACEMAKER All our Rom products are compatible with each other, but should you want, say, Wordpro with Kram, or Disk-o-pro with Visicalc, then SPACEMAKER will allow both Roms to address one Rom socket, with just the flip of a switch, for £22.50 plus Vat.

We are sole UK distributors for all these fine products. If your CBM dealer is out of stock, they are available by mail from us, by cheque/Access/Barclaycard (UK post paid) or send for details.

Calco Software

Lakeside House Kingston Hill Surrey KT27QT Tel 01-546-7256

• Circle No. 365



STACK'S APPLE SHOP



● fast delivery ● one year warranty ● full technical support

If you have questions
on these or any other
Apple orientated
product call
051 933 5511
(Carl Phillips or
Fiona McKendrick)

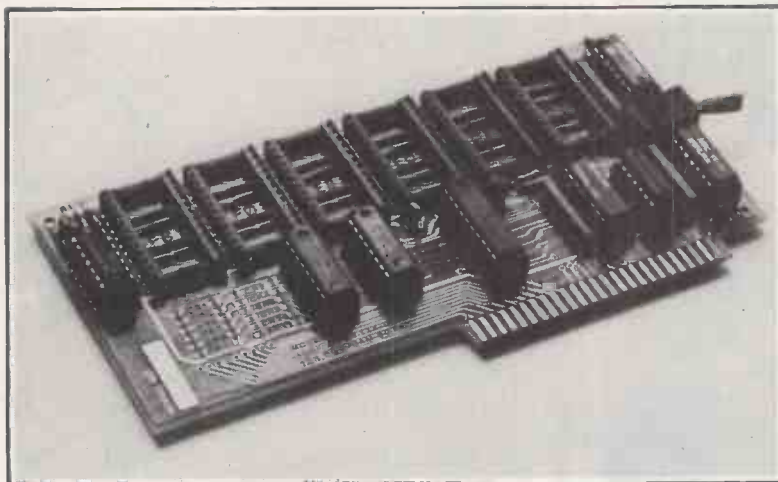

7114 12K ROM/PROM/RAM MODULE

The 7114 Card allows you to modify the firmware of the Apple-II Computer, without actually removing the on-board ROMS. The 7114 resides at locations D000-FFFF, using the INHibit signal to disable the Apple ROMS at these addresses. The 7114 provides six sockets for accepting any combination of 2316 ROMS, 2716 EPROMS, 4016 RAMS, or equivalent chips. Thus you can build your custom firmware in 2K increments. One, two or more chips may be employed at the

same time for programs longer than 2K. A reset toggle switch allows you to bring the board active when the system is turned on or reset. The board resides in any slot 1-6 and may be enabled and disabled under software control. There is no conflict between multiple 7114, language, ROM or RAM cards resident within a single Apple. For dedicated applications an assembler or Applesoft BASIC program can be stored on ROM and executed automatically on power-on.

Nett	VAT	Total
£70.00	£10.50	£80.50

MICROSOFT Z-80 SOFCARD

Microsofts innovative peripheral card turns Apple into one of the most flexible CP/M based systems you can buy. The Softcard actually contains a Z-80 processor and lets you switch between the Apples' 6502 and Z-80 with simple commands, so you can use software written for either processor.

The Softcard gives you the two software standards-CP/M 2.2 and Microsoft 5.0 Basic with PRINT... USING, 16 Digit precision, CALL, CHAIN, COMMON, powerful file handling. Applesofts' graphics extensions are also supported. Softcard allows you to run almost any CP/M based language or applications package.

Nett	VAT	Total
£170.00	£25.50	£195.50

MOUNTAIN HARDWARE COPYROM

CopyRom extends the power of Apples' disk operating system with resident programs to provide an improved 'CATALOG' command and copy diskettes. CopyRom allows you to identify disk volume number, free space on disk, determine active drive or change active drive, 'CATALOG' gives filename, length in sectors, file type and for binary files stored load address and length in hex or decimal. Copy program uses single or multiple drives, single or dual controller, thirteen or sixteen sector and some non-VTOC diskettes. CopyRom is a 2K ROM that installs on the ROMPLUS Card. Operates under all versions of Apple DOS and either BASIC.

Nett	VAT	Total
£30.00	£4.50	£34.50

CopyRom with ROM-PLUS Card and
Keyboard Filter ROM

Nett	VAT	Total
£130.00	£19.50	£149.50

**ALL PRODUCTS ON
THIS ADVERT ARE EX-
STOCK AT THE TIME OF
GOING TO PRESS!**

ANADEX GRAPHICS CARD

Our own printer card designed specifically for the Anadex DP9500/1 and new DP9000/1 printers. The card behaves as a normal Apple centronics interface but also includes powerful graphics dump software on the ROM permitting dot-for-dot reproduction of a hi-res image on the printer with almost any imaginable format - either hi-res, page, normal or inverse, expanded in X or Y directions with varying scale factors, left, right or centre justified across page.

Nett	VAT	Total
£140.00	£21.00	£161.00

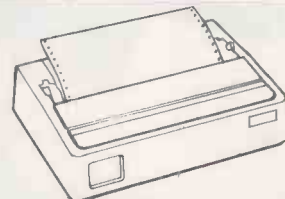

OKI MICROLINE 80

The reliable quiet, portable matrix printer that has become an industry standard. 40, 80 or 132 cols per line at 5, 10 or 16.5 cpi. Excellent print quality with three way paper handling - letterheads, fanfold or paper rolls. Centronics-type parallel interface (RS232 as an option) 96 character USASCII set with 2 x 3 pixel graphics.

Nett	VAT	Total
£325.00	£48.75	£373.75

SPECIAL!!

OKI Microline 80 with Centronics Aristocard, paper — everything you need to plug in to your Apple and go!

Nett	VAT	Total
£365.00	£54.75	£419.75

Please send me: _____

Cheque/P.O. enclosed for: £ _____

Name _____

Address _____

Prices include delivery.

Offical orders welcome.

STACK-APPLE 290-298 Derby Road,
Bootle, Liverpool 20.

Telephone: 051-933 5511. PCS/81

● Circle No. 366

NEW
SEIKOSHA

**The lowest cost,
smallest size,
80 column impact
dot graphic printer
in the world.**



GP80A

Suitable for home, educational and business use, the Seiksha GP80A features include:— Plain paper. 80 column width. 30 cps. Full ASCII character set. Graphics facility. 5 x 7 dot matrix. Double width characters. Pin feed. Centronics interface standard.

Other interface and cables available:— IEEE/488, PET, TANDY, APPLE, RS/232C.

Ring the Master Distributor, DRG Business Machines, (Supplies and Peripherals Division).
Weston-Super-Mare, (0934) 416392 or your nearest dealer:
Chromasonic Electronics London (01) 263 9493
Datalink Bristol (0272) 213427
Electronic Brokers London (01) 278 3461
Microdigital Liverpool (051) 227 2535
Sigma Systems Cardiff (0222) 21515
Watford Electronics Watford (0923) 40588
Westwood Computers Ltd Birmingham (021) 632 5842

DRG
BUSINESS
MACHINES

Unit 8, Lynx Crescent,
Winterstoke Road, Weston-Super-Mare,
Avon BS24 9DN Tel: (0934) 416392

**THE FINEST WORLDWIDE
SUPPORTED NATIONWIDE**

• Circle No. 367

**PLANNED
DATA
FURNITURE**

Terminal
work stations
stands/wing tables



trolley/tables
large range available
robust turntables

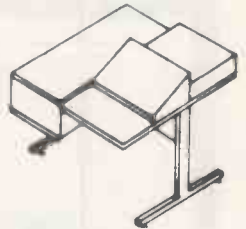
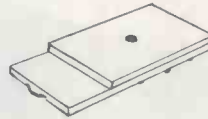
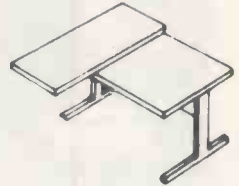

Roller bearing action
Pull out keyboard shelf

**Planned Data
Furniture
Co Ltd**

134 Chestergate
Stockport
Cheshire SK3-0AN
Telephone: 061-477 4890

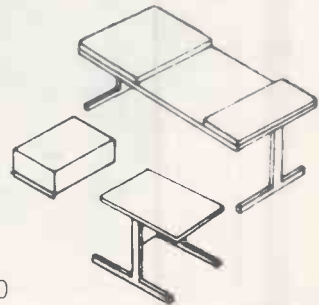

• Circle No. 368

***** COMPLETE BUSINESS PACKAGES *****
WIDELY USED IN UK AND USA
DEMONSTRATED IN THE NORTH BY THE EXCLUSIVE NORTHERN DISTRIBUTOR
Freshfield Computer Services

DEVELOPED BY
G.W. COMPUTERS LTD
**NOW AVAILABLE
FOR
DEMONSTRATION
IN THE NORTH
MAIN MENU
DISPLAY**

- * PROGRAMS ARE INTEGRATED . . .
SELECT FUNCTION BY NUMBER
- 01 = "ENTER NAMES AND ADDRESSES
 - 02 = "ENTER/PRINT INVOICES
 - 03 = "ENTER A'C RECEIVABLES
 - 04 = "ENTER PURCHASES
 - 05 = "ENTER A'C PAYABLES
 - 06 = "ENTER/UPDATE INVENTORY
 - 07 = "ENTER/UPDATE ORDERS
 - 08 = "ENTER/UPDATE BANKS
 - 09 = "REPORT SALES LEDGER
 - 10 = "REPORT PURCHASE LEDGER
 - 11 = "INCOMPLETE RECORDS
 - 12 = "USER DBMS AREA
 - 13 = "PRINT CUSTOMERS STATEMENTS
 - 14 = "PRINT SUPPLIER STATEMENTS
 - 15 = "PRINT AGENT STATEMENTS
 - 16 = "PRINT TAX STATEMENTS
 - 17 = LETTER TEXT AREA
 - 18 = ALTER VOCABULARIES
 - 19 = PRINT YEAR AUDIT
 - 20 = PRINT PROFIT LOSS A'C
 - 21 = OPEN AREA
 - 22 = PRINT CASHFLOW FORECAST
 - 23 = ENTER PAYROLL (NO RELEASE)
 - 24 = DISK SWAP/EXIT

FOR FULL DETAILS SEE GW COMPUTERS AD. (PAGE 12 AND 13)

SUPERBRAIN + SUPERBRAIN + SUPERBRAIN + SUPERBRAIN	
SUPERBRAIN 320K	1695.00
SUPERBRAIN 800K	2195.00
PRINTERS + PRINTERS + PRINTERS + PRINTERS + PRINTERS	1595.00
NEC-5530 PRINTER	1595.00
MICROLINE 80 120CPS	475.00

SOFTWARE + SOFTWARE + SOFTWARE + SOFTWARE +	
BUS VER 6.00 — 9.00	£775 — £975
BUS VER 7.00 CP/M	875.00
BUS VER 8.00 CP/M	975.00
BUS VER 9.00 CP/M	1075.00

Plus WORDSTAR—MAILMERGE—MBASIC 80—SUPERSORT etc.
Plus GRAHAM DORIAN SOFTWARE SYSTEMS—PAYROLL, STOCK
CONTROL, LEDGERS, etc. etc.

ALL SOFTWARE PACKAGES DEMONSTRATED BY APPOINTMENT.

CONTACT DAVID MAWDSLEY ON FORMBY (07048) 79186
RIPLEY HOUSE, 56 FRESHFIELD ROAD, FORMBY, MERSEYSIDE L37 3HW

• Circle No. 369

DATA LINK

Calling all serious
 **apple® users!**

Announcing Applied Analytics

FAST SPEED

The microspeed language system

- Runs six to sixty times faster than Basic.
- Programming capabilities well beyond Applesoft.
- Auxiliary Processor (Am 9511) for fast floating point.
- High-speed, extended high resolution graphics.
- Software development time cut in half.
- Exceptionally compact, compiled code.
- Extensible, structured language to meet your needs.
- Bonus: increased speed Applesoft functions.
- Requires 48K Apple 11 or 11+, single disk.

Sole distributors for UK and Europe
Retailer enquiries welcome

DATA LINK

10, Waring House Redcliffe Hill
BRISTOL BS1 6TB Tel: (0272) 213427

To: Datalink Microcomputer Systems Limited.

Please send Complete System £265 + VAT
 Detailed information

Name

Address

Tel No:

PCS/81

• Circle No. 370

£1150
+ VAT



VISUAL 100

The VISUAL 100 is a new microprocessor based video display terminal that offers total compatibility with the DEC VT100* from both a software and operator point of view.

For the operator, the detached solid-state keyboard has been customized so that all key positions and LED indicators are in identical location to that of the VT100.

For the software, all codes and features have been implemented in a manner identical to the VT100 assuring plug-to-plug compatibility.

The big difference between the VISUAL 100 and the DEC VT100 is that the VISUAL 100 offers features not available on the VT100, or available only as extra-cost options. These added features include:

- ETCHED NON-GLARE FACEPLATE
Your operator will appreciate viewing characters through an etched non-glare faceplate. This feature assures crisp, sharp character resolution even in the brightest office environ-

ments. Further, the tilt screen feature allows an adjustable viewing angle, 10° to 15°, for optimal viewing comfort.

- ADVANCED VIDEO PACKAGE IS STANDARD
Blink, bold, reverse video, and underline video attributes which can be used alone or in any combination for enhanced video presentations.
- CURRENT LOOP INTERFACE IS STANDARD
A 20mA current loop interface as well as an EIA RS232C interface.
- BUFFERED PRINTER INTERFACE OPTION
This option allows independent print/communication baud rates and independent parity. The printer option also allows the VISUAL 100 to function as a controller between host and printer, using "XON/XOFF" protocol. Printer busy can also be monitored using XON/XOFF, or control line.

Seeing is believing, so see for yourself. For a demonstration and a pleasant surprise on quantity pricing of the VISUAL 100, call or write us today.

• Circle No. 371

£675
+ VAT



VISUAL 200

The VISUAL 200 is a new, low cost, microprocessor based video display terminal which truly stands above competitive teletype compatible terminals in its price range.

In addition to the most popular features available (or partially available) on competitive terminals, such as numeric pad, upper/lower case, editing, current loop, cursor addressing, columnar and field tab, etc., standard features which set the VISUAL 200 apart and reach the optimum in human engineering and operator comfort include:

- Detachable Keyboard
- Smooth Scroll
- Tilt Screen (10° to 15° viewing angle)
- Large 7 x 9 Dot Matrix Characters

Perhaps the most distinctive feature of the VISUAL 200 is the Switchable Emulation capability. A switch on the rear panel programs the terminal for code-for-code emulation of a Hazeltine 1500, ADDS 520, Lear Siegler ADM-3A or DEC VT-52. To an O.E.M. customer it means no change in software to displace the older, less powerful terminals in his product line with the new, reliable and low cost VISUAL 200. To a Distributor it means offering a single modern terminal which is compatible with all the software his customers have written for the older terminals. And you're not limited to merely emulating these older terminals; you can outperform them at the same time by taking advantage of the additional features of the VISUAL 200.

Reliability designed into the VISUAL 200 is evidenced by its solid state keyboard, single P.C. Board and self test diagnostics on power up.

Seeing is believing, so see for yourself. For a demonstration and a pleasant surprise on quantity pricing of the powerful, easy to use and reliable VISUAL 200, call or write us today.

Standard Features

- 24 x 80 Screen Format
- 7 x 9 Dot Matrix
- Upper/Lower Case
- Numeric Pad
- Background/Foreground
- Blink Line
- Insert/Delete Line & Character
- Columnar and Field Tab
- Set/Clear Tab
- Security Mode (non-display)
- Clear End Line, Field & Page
- Clear Line
- Clear Screen
- Line Drawing
- Current Loop or RS-232 Interface
- Secondary Channel
- Composite Video
- Serial Copy Port
- Hold Screen
- Baud Rates to 19,200
- Self Test
- Cursor Addressing
- Cursor Control Keys
- Read Cursor Address
- Typamatic Keys
- Smooth Scroll
- Microprocessor
- Detachable Keyboard
- Solid State Keyboard
- Read Terminal Status
- Tilt Screen
- Switchable Emulations

• Circle No. 372

THE FIRST MICROCOMPUTER WHOLESALE



We offer products from
many manufacturers including:

Altos
Centronics
Century Data
Control Data
Datasouth
Dyna Byte
Hazeltine
Impact Data

Industrial Micro
Integral Data
Intertec
Konan
M, S, & C.
Malibu
Micro Peripherals
N.E.C.

North Star
Onyx
PerSci
Qume
Soroc
Televideo
Texas Instruments
Visual Technology

SIGMA (U.K.)
6, THE JAYS;
BURGESS HILL,
SUSSEX.

CATREI COMPUTERS
John F. Kennedy Avenue,
Dublin 12,
Ireland.

Telephone: 04446-44159

Telephone: Dublin 509714

DATASOUTH DS180 HIGH SPEED MATRIX PRINTER

£1490
+ VAT

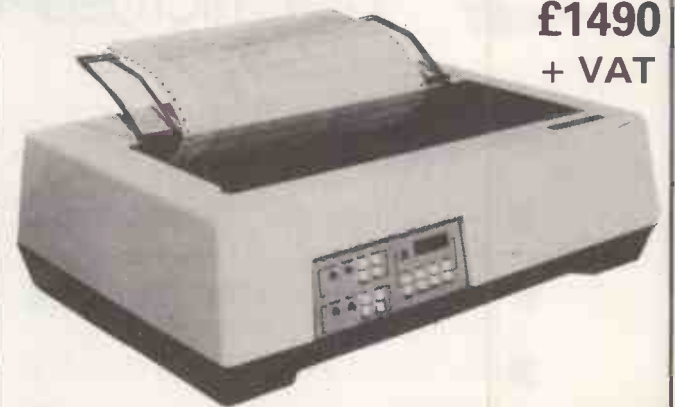

The Datasouth DS180 is a dot-matrix serial impact printer designed for high performance at an economical price. Application flexibility and a long list of standard features make the DS180 an ideal device for small business systems, distributed communications networks and intelligent terminals.

HIGH SPEED PRINTING

Utilizing 180 cps optimized bidirectional printing, the DS180 offers higher throughput than any printer in its class. Its 9-wire printhead produces highly legible 6x7 characters with descenders for lower case letters and true underlining. All 96 ASCII characters may be printed across a 132 column line at 10 characters per inch. Expanded characters (5 cpi) may be selected for highlighting portions of the text.

USER PROGRAMMABLE

The DS180 offers a large number of user programmable features, yet is easy to operate. A unique programming keypad with a non-volatile memory makes printer set-up quick and simple. Top of form, horizontal and vertical tabs, perforation skip-over and auto line feed are just a few of the features the user may select. Communications status may also be programmed and monitored using the indicator panel lights and LED display.

ATTRACTIVE DESIGN

Compact, desk-top packaging allows the DS180 to fit into almost any installation. Its noise dampening cover makes it suitable for use in a quiet office environment. The cartridge ribbon makes routine changes clean, fast and convenient.

MICROPROCESSOR ELECTRONICS

Through the use of state-of-the-art microprocessor electronics, reliability and maintainability have been greatly improved. The simple modular design of the DS180 provides easy access to all major components. A single printed circuit board contains both

the power supply electronics and digital controller for the printer. A self-test feature and diagnostic display panel help the user verify proper operation of the unit and isolate problems should they occur.

COMMUNICATIONS

Interfaces on the DS180 include RS232 and 20mA current loop serial interfaces, and a Centronics compatible parallel interface. Baud rates from 110-9600 and parity selection may be keyed in by the user for his specific application.

FORMS HANDLING

Adjustable tractor accommodates forms from 3-15 inches wide. A head-to-platen gap adjustment ensures optimum print quality on up to 6-part forms. Fanfold paper may be fed from the front or bottom of the DS180. A paper out sensor may be programmed to send a stop transmission character and sound an audible alarm.

QUALITY MANUFACTURING

Reliable performance is ensured by a stringent quality control program. Datasouth uses pretested, high reliability parts from leading manufacturers. Multiple tests are performed on sub assemblies during each stage of production, with each completed unit undergoing a final 24 hour print test and burn-in. The DS180 carries a 90 day warranty on materials and workmanship.

• Circle No. 373

SYSTEMICS LIMITED

3 Hillberry Court, School Lane,
Bushey, Hertfordshire WD2 1BS
(01) 422 3276 (24 hours)



HI-RES PROBLEM SOLVER £45

an all purpose hi-res processor, includes upper/lower case, mixed graphics and text, two way window scrolling, user shape definition with rotation, enlargement, slanting, stretching, reflection, inversion and many other hi-res functions.

LITERATURE SEARCH £25

a suite of four programs forming a complete magazine article filing system allowing retrieval of references to items by keyword(s) within category.

MANY OTHER QUALITY PACKAGES INCLUDE

Club membership	£95
Linear programming	£85
Time recording	£125
Mailing list	£75

DEALER ENQUIRIES INVITED

• Circle No. 374

The SENSATIONAL CROFTON Offer



9" metal cased monitor at lowest ever price – £48.50 plus VAT – £55.77 total plus carriage.

P31 green tube models available at £60 + VAT – £69 total + carriage

STOCKISTS IN ALL AREAS WANTED. WRITE FOR DETAILS.

12" Model available at following prices.
Standard P4 white £145 + VAT
£166 total + carriage
Standard P31 green £160 + VAT
– £184 + carriage

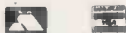

Ask for Crofton Mail
All major credit cards accepted. Order Catalogue.

All items subject to availability. The above prices include VAT
Carriage will be charged at cost

Phone or write to

CROFTON ELECTRONICS LIMITED

35 Grosvenor Road, Twickenham, Middx TW1 4AD.
Tel: 01-891 1923/1513

• Circle No. 375

Advertisement Index

A	Acorn Computers	168	David Richard	188	L	Leicester Computer Centre	146	Q	Qudos	190
	Aculab	184	Davinci	29		Lifeboat Associates	10,11			
	AJD Direct Supplies	36	3D Computers	196		Liveport	90			
	A J Harding	95	3D Digital Design	104		L & J Computer Centre	22	R		
	Alan Kiddle	69	DDP	184		London Computer Centre	24,153	Rair		51
	Algray	196	Digitus	40		Lowe Electronics	29	Research Resources		164
	Almarc	148	Display Electronics	35		L.P. Enterprises	14,15	Rohan		183
	Anadex	86,87	E					Russett		149
	Anglia Consultancy	182	EMG	29	M					
	Applied Data Education	158	Encotel	33		Manchester University	34	S		
	A W Hawkins	39	Epson	98,146		Melbourne House	178	SBD Consultants		172
B			Equinox	57		Micro 80	188	Science of Cambridge		88,89
Barcellos	165		Europhonics	201		Micro Byte	194	Sharp Electronics		21
BHRA Fluid Engineering	174		Exchange Telegraph	156		Micro Centre	2	Shelton		118
Bits & PC's	156		F			Microcosm	26	Sigma UK		216
Brindlywell	158		Gate	180		Micro Data	22	Sintrom Microshop		176
Buss Stop	165		GP Industrial Electronics	193		Micro Faculties	157	Sirtron Computers		151
Butel Comco	192		Graffcom	37		Micro General	164	Small Systems		178
			Graham Dorian	117		Micro Management	70	Southdata		150
			Grama Winter	16,17		Micropute	116	Sun Computing Services		115
			Guestel	187		Microperipherals	27,38	Swan Packaging		43
C			H			Micro Solution	25	Swanley Electronics		43
Calisto	20		Hal Computers	45		Microsense	48	Systematics		167
Cambridge Computer Store	158		Hanover Fair	155		Microstyle	36	Systemics		217
Camden Electronics	180		Hewlett Packard	31		Microtek	65			
Chris Pym Ltd	34		Hi-Tech	179		Microtrend	154	T		
Chromasonic	23		Hurricane Computers	190		MMS	165	Tags		54
Comart	5		I			N		Telesystems		163
Commodore	8,9		Informex Centralex	164		Nascom	30	Terminal Display		172
Community Computer	169		Independent Computer Engineers	174		Newbear	24	Tex Micro Systems		178
Compshop	218,219		Imac	43		Newtronics	101	This Could Be (Leisure) Ltd		26
Computace	108		Integrated Supplies	160		Nexas	159	Tower Management		172
Computech	197		Intelligent Artifacts	62,182		Northern Development Corporation	19	Transdata		80
Computerbits	181		Interactive Data Systems	52		Northern Software	152	Transam		161,185
Computer Centre	72		Ithaca Intersystems	220		O		T V Johnson		189
Computer For All	43		Inmac	69		Ohio Scientific	177	V		
Computer Store	4		J			Office Computer Techniques	171	Visconti		77,98
Computer Supermarket	175		JS Systems	196		Oxford Computer System	162	V&T Electronics		192
CPS (Data Systems)	18,149,160		K			P		W		
Crofton	217		Keyltron	32		Paxton Computers	186	Watford		6,7
Crystal	26,162		Keytronic	155		Personel Computers	53	West London Micro Centre		39
CTS	176		KGB	191		Pete & Pam Computers	34			
Cumana	173		Kram	150		Petalect	162			
Curry's Microcentre	12,13					Professional Data Systems	28	Z		
Contactrol	192					Prentice Hall	186	Zero 1		160
D						Purley Computing	32			
Dataplus	166									
Datatech	39									

EXTENDED GUARANTEE BY COMPUKARE

THE NEW ANADEX DP9500 and DP9501

A PROFESSIONAL PRINTER



- Bi-directional printing
- Up to 220 chars/line with 4 print densities
- 500 char buffer
- RS232C and Centronics Parallel interface built in
- Full software control of matrix needles allowing graphics capability
- 200 chars/sec
- Adjustable width tractor feed.

DP9500 — ONLY £795 + VAT
DP9501 — ONLY £845 + VAT

RRP £540 only **£399** + VAT
ANADEX DP8000

Super Quality — Low cost printer. Tractor Feed with full 96 ASCII character set. Accepts RS232C at band rates between 100 and 9600 and Parallel Bit data. Attaches either directly or through interfaces to Pet, Apple, TRS80, Sorcerer, Nascom, Kompukit etc.

EXTENDED GUARANTEE BY COMPUKARE

WE ARE NOW STOCKING THE AUTOSTART APPLE II AT REDUCED PRICES

16K **£549**
32K **£579**
48K **£599** + VAT

EXTENDED GUARANTEE BY COMPUKARE

Getting Started APPLE II is faster, smaller, and more powerful than its predecessors. And it's more fun to use too because of built-in features like:

- BASIC — The Language that Makes Programming Fun.
- High-Resolution Graphics (in a 54,000-Point Array) for Finely-Detailed Displays.
- Sound Capability that Brings Programs to Life.
- Hand Controls for Games and Other Human-Input Applications.
- Internal Memory Capacity of 48K Bytes of RAM, 12K Bytes of ROM; for Big-System Performance in a Small Package.
- Eight Accessory Expansion Slots to let the System Grow With Your Needs.

You don't need to be an expert to enjoy APPLE II. It is a complete, ready-to-run computer. Just connect it to a video display and start using programs (or writing your own) the first day. You'll find that its tutorial manuals help you make it your own personal problem solver.

INTRODUCING THE NEW & EXCITING TRS80 MODEL III

16K **£559** + VAT 32K **£589** + VAT 48K **£619** + VAT

EXTENDED GUARANTEE BY COMPUKARE

The Radio Shack TRS-80™ Model III is a ROM-based computer system consisting of:

- A 12-inch screen to display results and other information
- A 65-key console keyboard for inputting programs and data to the Computer
- A Z-80 Microprocessor, the "brains" of the system
- A Real-Time Clock
- Read Only Memory (ROM) containing the Model III BASIC language (fully compatible with most Model I BASIC programs)
- Random Access Memory (RAM) for storage of programs and data while the Computer is on (amount is expandable from "16K" to "48K", optional extra)
- A Cassette Interface for long-term storage of programs and data (requires a separate cassette recorder, optional/extra)
- A Printer Interface for hard-copy output of programs and data (requires a separate line printer, optional/extra)
- Expansion area for upgrading to a disk-based system (optional/extra)
- Expansion area for an RS-232-C serial communications interface (optional/extra)

All these components are contained in a single moulded case, and all are powered via one power cord.

THE ATARI VIDEO COMPUTER GAMES SYSTEM

Atari's Video Computer System now offers more than 1300 different game variations and options in twenty Game Program™ cartridges!

Most Cartridges only **£13.90** + VAT
Prices may vary with special editions

Basic Maths, Airsea Battle, Black Jack, Breakout, Surround, Spacewar, Video Olympics, Outlaw, Basketball, Hunt & Score*, Space War, Sky Diver, Air Sea Battle, Codebreaker*, Miniature Golf.

Extra Paddle Controllers — **£14.90** + VAT *Keyboard Controllers — **£16.90** + VAT

SPACE INVADERS NOW IN STOCK **£25**

EXTENDED GUARANTEE BY COMPUKARE

SPECIAL OFFER FOR MODEL III PURCHASERS

We will take keyboards only for TRS80 Model I and Level II in part exchange.

There will be refurbished Model I and Level II keyboards available later in the year — Phone for availability and price.

HITACHI PROFESSIONAL MONITORS

9" — ~~£129~~ **£99.95**
12" — ~~£199~~ **£149**

- Reliability Solid state circuitry using an IC and silicon transistors ensures high reliability.
- 500 lines horizontal resolution Horizontal resolution in excess of 500 lines is achieved in picture center.
- Stable picture Even played back pictures of VTR can be displayed without jittering.
- Looping video Input Video input can be looped through with built-in termination switch.
- External sync operation (available as option for U and C types)
- Compact construction Two monitors are mountable side by side in a standard 19-inch rack.

EXTENDED GUARANTEE BY COMPUKARE

only **£295** + VAT

Expand your TRS80 by 32K 32K Memory on board. Centronics parallel port. Disk controller card. Real time clock. Requires Level II Basic. Interface for 2 cassette decks. complete with power supply.

TRS80 EXPANSION INTERFACE

EXTENDED GUARANTEE BY COMPUKARE

APPLE DISC II 3.3 Dos

Disc with Controller **£349** + VAT
Additional Drives **£299** + VAT

- Powerful Disk Operating Software Supports up to 6 drives
- Name Access to Files for Ease of Use
- BASIC Program Chaining to Link Software Together
- Random or Sequential File Access to Simplify Programming
- Dynamic Disk Space Allocation for Efficient Storage
- Individual File Write-Protection Eliminates Accidental File Alterations
- Loads an 8K Byte Binary Image in 6.5 sec. (1.2 sec. in Pascal)
- Storage Capacity of 116 Kilobytes (143K Bytes with Pascal) on Standard 5¼" Diskettes
- Powered Directly From the APPLE (Up to 6 Drives) for Convenience and High Reliability
- Packaged in Heavy-Duty, Colour-Coordinated Steel Cabinet

EXTENDED GUARANTEE BY COMPUKARE

We give a full one year's guarantee on all our products, which normally only carry 3 months guarantee.

We have one of the largest collections of Computer Books under one roof, along with racks of software for the PET and TRS80. Come and see for yourself.

LOW COST TELEPHONE ANSWERING MACHINE

only **£99.95** + VAT

Microprocessor controlled answering machine. Plug into your phone line. Records any phone call messages. Remote bleeper enables you to listen to your messages from anywhere in the world. Uses standard cassettes. Comes complete with mains adaptor, microphone, remote bleeper, base unit, cassette with 30 sample pre-recorded messages.

EXTENDED GUARANTEE BY COMPUKARE

NEC SPINWRITER

only **£1350** + VAT

NEC's high quality printer uses a print "thimble" that has less diameter and inertia than a daisy wheel, giving a quieter, faster, more reliable printer that can cope with plotting and printing (128 ASCII characters) with up to five copies, friction or tractor fed. The ribbon and thimble can be changed in seconds. 55 characters per second bidirectional printing — with red/black, bold, subscript, superscript, proportional spacing, tabbing, and much, much more.

EXTENDED GUARANTEE BY COMPUKARE

THE VIDEO GENIE SYSTEM

Ideal for small businesses, schools, colleges, homes, etc. Suitable for the experienced, inexperienced, hobbyist, teacher, etc.

EG3000 Series

WITH NEW EXTRA KEYS!

16K **£279** - VAT

- 16K user RAM plus extended 12K Microsoft BASIC in ROM
- Fully TRS-80 Level II software compatible
- Huge range of software already available
- Self contained, PSU, UHF modulator, and cassette
- Simply plugs into video monitor or UHF TV
- Full expansion to disks and printer
- Absolutely complete — just fit into mains plug.

The Video Genie is a complete computer system, requiring only connection to a domestic 625 line TV set to be fully operational; or if required a video monitor can be connected to provide the best quality display. 51 key typewriter style keyboard, which features a 10 key rollover. Supplied with the following accessories:-

- BASIC demonstration tape;
- Video lead;
- Second cassette lead;
- Users manual;
- BASIC manual;
- Beginners programming manual.

Write useful programs in the BASIC computer language yourself.

EXTENDED GUARANTEE BY COMPUKARE

COMP PRO MIXER

Professional audio mixer that you can build yourself and save over **£100.**

Only **£99.90** plus VAT for complete kit. Plus FREE power supply valued at **£25.00**

ACCESSIT AUDIO ADD-ONS

EXTENDED GUARANTEE BY COMPUKARE

TEAC DISK DRIVES

40 TRACK
Single Disk Drive **£225** + VAT Double Disk Drive **£389** + VAT

77 TRACK
Single Disk Drive **£299** + VAT Double Disk Drive **£499** + VAT

- TEAC FD-50A has 40 tracks giving 125K Bytes unformatted single density capacity.
- The FD-50A can be used in double density recording mode.
- The FD-50A is Shugart SA400 interface compatible.
- Directly compatible with Tandy TRS80 expansion interface.
- Also interfaces with Video Genie, SWTP, Heathkit, North Star Horizon, Superbrain, Nascom, etc, etc.
- Address selection for Daisy chaining up to 4 Disks.
- Disks plus power supply housed in an attractive grey case.

EXTENDED GUARANTEE BY COMPUKARE

NEW VIDEO GENIE EXPANSION BOX

Complete with RS232 interface and floppy disc controller. O memory. **£225** + VAT.

Memory expansion card (S100) 16K **£110** 32K **£159** + VAT
Further S100 cards available later in the year.

EXTENDED GUARANTEE BY COMPUKARE

NOBODY CAN GET OUR PRICES EXCEPT OUR CUSTOMERS

NASCOM 2 DISC DRIVES

ADD A powerful, double density, mini floppy disc to your Nascom system.

- Disc Controller Card (includes Nasbus 6 S100 interface)
- Will control 4 Drives.
- CPM operating system.
- Extended Disc Basic Compiler.
- Power supply included

One Disc System — £499 + VAT
Additional Disc Unit — £299 + VAT



NASCOM 2 GAMES TAPE

featuring Space Invaders and Android Nim, Re-numbering program and other goodies!

£7.50 + VAT

NEW REDUCED PRICES

8K £399
16K £449
32K £499

RRP £795 for 32K



The PEDIGREE PETS

Very popular for home & business use. 8K Microsoft Basic in ROM. 8K Pet 32K & 16K with new improved keyboard. All with green screen.

Cassette Deck £55 extra Full range of software available.

Interface PET IEEE — Centronics Parallel
Decoded £77.00 + VAT

GET YOURSELF A NEW MX80 PRINTER AND SAVE A FORTUNE

only £299 + VAT

Interface Cards for Apple, Pet, TRS80, Nascom and CompuKit — RS232 Interface Cards not necessary for parallel.

£49 + VAT

Full TRS80/Genie Graphics including cables. Ready to go. **EX-STOCK.**



COMP POCKET COMPUTER GREATEST BREAKTHROUGH YET

£79.90 + VAT

COMPUTER POWER THAT ONCE FILLED A ROOM CAN NOW BE CARRIED IN YOUR POCKET!

- Programs in BASIC
- "QWERTY" Alphabetic Keyboard
- 1.9K Random Access Memory
- Long Battery Life.

Computer power that once filled a room can now be carried in your pocket! It's easy to load with ready-to-run software from cassette tape (interface and recorder optional) or program it yourself in easy-to-learn BASIC. 24-character liquid crystal readout displays one line at a time. Special feature is advanced non-volatile memory allows you to power on and off without losing the contents of memory. Note: Memory must be transferred to tape before changing batteries. Automatic statement compaction squeezes every ounce of memory space. Features power-off retention of programs and data. Powerful resident BASIC language includes multiple statements, math functions, editing, strings, arrays and much more. Multiple program loading capability subject to RAM availability. Carrying case and batteries included.



EUROPE'S FASTEST SELLING ONE BOARD COMPUTER.

COMPUKIT UK101

★ 6502 based system — best value for money on the market. ★ Powerful 8K Basic — Fastest around ★ Full Qwerty Keyboard ★ 4K RAM Expandable to 8K on board. ★ Power supply and RF Modulator on board. ★ No Extras needed — Plug-In and go ★ Kansas City Tape Interface on board. ★ Free Sampler Tape including powerful Disassembler and Monitor with each Kit. ★ If you want to learn about Micros, but didn't know which machine to buy then this is the machine for you.

NEW ISSUE COMPUKIT WITH ALL THE FEATURES THAT MADE IT THE MOST PROFESSIONAL COMPUTER KIT ON THE MARKET. Now WITH FREE MONITOR (a saving of £22), which includes Flashing Cursor, Screen Editing, & Save Data on Tape.

DEALER ENQUIRIES INVITED

Fully assembled £199.00

NEW EXTENDED MONITOR IN EPROM — available separately at £22 + VAT

Improved BASIC function — revised GARBAGE routine. Allows correct use of STRING ARRAYS. This chip can be sold separately to existing CompuKit and Superboard users.

Build, Understand and Program your own Computer for only a small outlay

KIT ONLY £149 + VAT NO EXTRAS NEEDED

FOR THE COMPUKIT — Assembler Editor £14.90 Screen Editor Tape £1.90 4K Upgrade £15.90
GAME PACKS — 1). Four Games £5.00 2). Four Games £5.00 3). Three Games 8K only £5.00
Super Space Invaders (8K) £6.50 Space Invaders £5.00 Chequers £3.00 Realtime Clock £3.00
Case for CompuKit £29.50 40 pin Expansion Jumper Cable £8.50 All Prices exclusive VAT



TV GAME BREAK OUT

Has got to be one of the world's greatest TV games. You really get hooked. As featured in ETI. Has also 4 other pinball games and lots of options. Good kit for up-grading old amusement games.

MINI KIT — PCB, sound & vision modulator, memory chip and de-code chip. Very simple to construct. £14.90 + VAT
OR PCB £2.90 MAIN LSI £8.50 Both plus VAT



A SELECTION OF APPLE INTERFACES ARE NOW AVAILABLE AT OUR NEW SHOWROOM.

MEMORY UPGRADES

16K (8 x 4116) £15.90 + VAT
4K CompuKit (8 x 2114) £15.90 + VAT

WHETHER OR NOT YOU PURCHASE YOUR PRODUCTS FROM US OR NOT - OUR STAFF OF HIGHLY TRAINED ENGINEERS WILL BE ONLY TO PLEASED TO CARRY OUT ANY REPAIRS NECESSARY

OUR SHOWROOM & SALES CENTRE AT

311 Edgware Road, London W2

8MHz Super Quality Modulators	£4.90
6MHz Standard Modulators	£2.90
C12 Computer Grade Cassettes	10 for £4.00
Anadex Printer Paper — 2000 sheets	£25.00
Floppy Discs 5 1/4" Hard and Soft Sector	£3.50
Floppy Disc Library Case 5 1/4"	£3.50
Verocases for Nascom 1 & 2 etc.	£24.90

SPECIAL OFFER

We will part exchange your Sinclair ZX80 for any of our products.

Refurbished ZX80's } fully
Refurbished MicroAces } guaranteed } £69.90 + VAT
(Supply dependant upon stocks).



ENGLISH COLOUR TV/ AMERICAN NTSC COLOUR MONITOR

Suitable for Apple, Atari and Texas 99/4 £295 + VAT

FANTASTIC FOR FILE HANDLING ACULAB FLOPPY TAPE

The tape that behaves like a disc, for TRS-80 LEVEL 2. £169 + VAT

The Aculab Floppy Tape for the TRS-80 and Video Genie is a highly reliable digital storage system that provides many of the advantages of floppy disks at less cost. Automatic debounce routine for the Level 2 keyboard. Connects directly to TRS-80 Level 2 Keyboard. Operating and file handling software in ROM. 8 commands add 12 powerful functions to Level 2 BASIC.



COMP SHOP

"Europe's Largest Discount Personal Computer Stores"

Delivery is added at cost. Please make cheques and postal orders payable to **COMP SHOP LTD.**, or phone your order quoting **BARCLAYCARD, ACCESS, DINERS CLUB** or **AMERICAN EXPRESS** number.

MAIL ORDER AND SHOP: CREDIT FACILITIES ARRANGED — send S.A.E. for application form.

14B Station Road, New Barnet, Hertfordshire, EN5 1QW (Close to New Barnet BR Station — Moorgate Line).
Telephone: 01-441 2922 (Sales) 01-449 6536 Telex: 298755 TELCOM G

OPEN (BARNET) — 10am - 7pm — Monday to Saturday

NEW WEST END SHOWROOM:

311 Edgware Road, London W2. Telephone: 01-262 0387

OPEN (LONDON) — 10am - 6pm — Monday to Saturday

- ★ IRELAND: 80 Marlborough Street, Dublin 1. Telephone: Dublin 749933
- ★ COMP SHOP USA, 1348 East Edinger, Santa Ana, California, Zip Code 92705. Telephone: 0101 714 5472526

TELEPHONE SALES OPEN 24 hrs. 7 days a week. 01-441 2922

BARCLAYCARD VISA AMERICAN EXPRESS DINERS CLUB INTERNATIONAL



Outside of the garden you need a computer that can grow.

For the common or garden hobbyist, a high quality personal computer is a real temptation. But let's face it: in the world of business, engineering and scientific applications, you need a system that has been designed from the ground up to allow flexibility and expansion.

Providing flexibility and expandability today allows the micro to move up to and beyond the level of yesterdays mini. Hard disks for big system memory; more peripherals for big system flexibility; more number crunching capability and programming power can all be added when you need them. And without the feeling that you are turning a good natured toytown machine into a disproportionate monster.

The Ithaca InterSystems DPS1 has the power and flexibility of the IEEE 696 S100 bus with 20 slots of expandability for up to 16 individually addressable DMA devices and up to 1 MegaByte direct addressing from our Z80 board with its unique memory management system.

For really serious computing, our optional hardware front-panel provides a powerful diagnostic tool for debugging and development. Among its many features are the ability to deposit into and examine memory and set hardware breakpoints. Coupled with an oscilloscope, many other activities usually associated with expensive logic analyzers are possible. No wonder it's fast becoming the chosen development system in laboratories everywhere. And the recently announced system without the hardware frontpanel sets new standards for target systems too.

On the subject of standards, Ithaca InterSystems Series II is the most complete line of IEEE 696 S100 boards . . . easily upgradeable to the Z8000 or other 16 bit processors as they become available . . . so you never get locked out of rapid

expansion, or locked into obsolescence, by depending on a single manufacturer.

But beware: IEEE 696 is an 8 bit AND 16 bit standard, not 8 bit only as some would have you believe. True compatibility and later upgrade to 16 bits means you need to stick to the full IEEE 696 S100 standard from the start.

So if you've left the common or garden variety applications behind, come to Ithaca InterSystems and get a system that will grow as big as your next idea. Whether starting out with a basic low cost system or needing a sophisticated full feature multiuser system or anything in between . . . you'll find a solution to your problem with Ithaca InterSystems. With a choice of 5" or 8" drives, hard disks and CP/M or MP/M, and the full range of CP/M compatible software, including the excellent PASCAL/Z native code compiler, we probably have what you need.

Why not contact us to discuss your requirement? Call today for a catalogue of our products which also contains details of the IEEE S100 bus.

Coleridge Lane, Coleridge Road,
London N8 8ED, England.

Telephone: 01-341 2447
Telex: 299568

ITHACA InterSystems (UK) Ltd.

"MAKING MICROCOMPUTERS FOR THE '80s"